

SECTION AT

CONTENTS

TROUBLE DIAGNOSIS — INDEX	2	Symptom Chart.....	69
Alphabetical & P No. Index for DTC	2	TCM Terminals and Reference Value.....	80
PRECAUTIONS	4	TROUBLE DIAGNOSIS FOR POWER SUPPLY	84
Precautions for Supplemental Restraint System		Wiring Diagram — AT — MAIN.....	84
(SRS) "AIR BAG".....	4	DTC P0705 INHIBITOR SWITCH	86
Precautions for On Board Diagnostic (OBD)		Description.....	86
System of A/T and Engine.....	4	Wiring Diagram — AT — INH/SW.....	88
Precautions.....	4	Diagnostic Procedure.....	89
Service Notice or Precautions.....	6	Component Inspection.....	90
Wiring Diagrams and Trouble Diagnosis.....	7	DTC P0710 A/T FLUID TEMPERATURE SENSOR	
PREPARATION	8	CIRCUIT	91
Special Service Tools	8	Description.....	91
OVERALL SYSTEM	10	Wiring Diagram — AT — FTS.....	93
A/T Electrical Parts Location	10	Diagnostic Procedure.....	94
Circuit Diagram.....	11	Component Inspection.....	95
Cross-sectional View	12	DTC P0720 VEHICLE SPEED SENSOR A/T	
Hydraulic Control Circuit.....	13	(REVOLUTION SENSOR)	96
Shift Mechanism	14	Description.....	96
Control System.....	23	Wiring Diagram — AT — VSSAT.....	98
Control Mechanism.....	24	Diagnostic Procedure.....	99
Control Valve	29	Component Inspection.....	100
ON BOARD DIAGNOSTIC SYSTEM		DTC P0725 ENGINE SPEED SIGNAL	101
DESCRIPTION	31	Description.....	101
Introduction	31	Wiring Diagram — AT — ENGSS.....	103
OBD-II Function for A/T System.....	31	Diagnostic Procedure.....	104
One or Two Trip Detection Logic of OBD-II	31	DTC P0731 IMPROPER SHIFTING TO 1ST GEAR	
OBD-II Diagnostic Trouble Code (DTC).....	31	POSITION	105
Malfunction Indicator Lamp (MIL).....	35	Description.....	105
CONSULT.....	35	Wiring Diagram — AT — 1ST.....	108
TROUBLE DIAGNOSIS — INTRODUCTION	48	Diagnostic Procedure.....	109
Introduction	48	Component Inspection.....	110
Work Flow.....	52	DTC P0732 IMPROPER SHIFTING TO 2ND GEAR	
TROUBLE DIAGNOSIS — BASIC INSPECTION	54	POSITION	111
A/T Fluid Check.....	54	Description.....	111
Stall Test.....	54	Wiring Diagram — AT — 2ND.....	114
Line Pressure Test.....	57	Diagnostic Procedure.....	115
Road Test.....	58	Component Inspection.....	115
TROUBLE DIAGNOSIS — GENERAL		DTC P0733 IMPROPER SHIFTING TO 3RD GEAR	
DESCRIPTION	69	POSITION	117

CONTENTS (Cont'd)

Description	117	Diagnostic Procedure	176
Wiring Diagram — AT — 3RD.....	120	Component Inspection.....	177
Diagnostic Procedure	121	VEHICLE SPEED SENSOR-MTR.....	178
Component Inspection.....	121	Description	178
DTC P0734 IMPROPER SHIFTING TO 4TH GEAR		Wiring Diagram — AT — VSSMTR.....	180
POSITION	123	Diagnostic Procedure	181
Description	123	TROUBLE DIAGNOSES FOR SYMPTOMS	182
Wiring Diagram — AT — 4TH.....	127	Wiring Diagram — AT — NONDTC.....	182
Diagnostic Procedure	128	1. O/D OFF Indicator Lamp Does Not Come On....	185
Component Inspection.....	131	2. Engine Cannot Be Started In "P" and "N"	
DTC P0740 TORQUE CONVERTER CLUTCH		Position	187
SOLENOID VALVE.....	132	3. In "P" Position, Vehicle Moves Forward Or	
Description	132	Backward When Pushed	188
Wiring Diagram — AT — TCV.....	134	4. In "N" Position, Vehicle Moves.....	189
Diagnostic Procedure	135	5. Large Shock. "N" → "R" Position	191
Component Inspection.....	136	6. Vehicle Does Not Creep Backward In "R"	
DTC P0744 IMPROPER LOCK-UP OPERATION	137	Position	192
Description	137	7. Vehicle Does Not Creep Forward In "D", "2"	
Wiring Diagram — AT — TCCSIG	140	Or "1" Position	194
Diagnostic Procedure	141	8. Vehicle Cannot Be Started From D ₁	196
Component Inspection.....	144	9. A/T Does Not Shift: D ₁ → D ₂ Or Does Not	
DTC P0745 LINE PRESSURE SOLENOID VALVE	145	Kickdown: D ₄ → D ₂	198
Description	145	10. A/T Does Not Shift: D ₂ → D ₃	200
Wiring Diagram — AT — LPSV.....	147	11. A/T Does Not Shift: D ₃ → D ₄	202
Diagnostic Procedure	148	12. A/T Does Not Perform Lock-up.....	204
Component Inspection.....	149	13. A/T Does Not Hold Lock-up Condition	205
DTC P0750 SHIFT SOLENOID VALVE A	151	14. Lock-up Is Not Released.....	206
Description	151	15. Engine Speed Does Not Return To Idle (Light	
Wiring Diagram — AT — SSV/A	153	Braking D ₄ → D ₃)	207
Diagnostic Procedure	154	16. Vehicle Does Not Start From D ₁	208
Component Inspection.....	155	17. A/T Does Not Shift: D ₄ → D ₃ , When	
DTC P0755 SHIFT SOLENOID VALVE B	156	Overdrive Control Switch "ON" → "OFF"	209
Description	156	18. A/T Does Not Shift: D ₃ → 2 ₂ , When Selector	
Wiring Diagram — AT — SSV/B	158	Lever "D" → "2" Position	210
Diagnostic Procedure	159	19. A/T Does Not Shift: 2 ₂ → 1 ₁ , When Selector	
Component Inspection.....	160	Lever "2" → "1" Position	211
DTC P1705 THROTTLE POSITION SENSOR	161	20. Vehicle Does Not Decelerate By Engine	
Description	161	Brake.....	211
Wiring Diagram — AT — TPS	164	21. TCM Self-diagnosis Does Not Activate	
Diagnostic Procedure	165	(Inhibitor, Overdrive Control and Throttle Position	
Component Inspection.....	167	Switches Circuit Checks).....	212
DTC P1760 OVERRUN CLUTCH SOLENOID		A/T SHIFT LOCK SYSTEM.....	218
VALVE.....	168	Description	218
Description	168	Wiring Diagram — SHIFT —.....	219
Wiring Diagram — AT — OVRCSV.....	170	Diagnostic Procedure	220
Diagnostic Procedure	171	Component Check.....	222
Component Inspection.....	172	KEY INTERLOCK CABLE	223
DTC BATT/FLUID TEMP SEN A/T FLUID		Components.....	223
TEMPERATURE SENSOR CIRCUIT AND TCM		Removal.....	223
POWER SOURCE	173	Installation.....	224
Description	173	ON-VEHICLE SERVICE	225
Wiring Diagram — AT — BA/FTS	175	Control Valve Assembly and Accumulators.....	225

CONTENTS (Cont'd)

Revolution Sensor Replacement.....	226	Forward Clutch Drum Assembly.....	277
Rear Oil Seal Replacement.....	226	Rear Internal Gear and Forward Clutch Hub.....	279
Parking Components Inspection.....	226	Band Servo Piston Assembly.....	282
Inhibitor Switch Adjustment.....	227	Parking Pawl Components.....	286
Manual Control Linkage Adjustment.....	227	ASSEMBLY.....	288
REMOVAL AND INSTALLATION.....	228	Assembly (1).....	288
Removal.....	228	Adjustment.....	292
Installation.....	229	Assembly (2).....	296
OVERHAUL.....	231	A/T FLUID COOLER SYSTEM.....	306
Components.....	231	A/T Fluid Cooler.....	306
Oil Channel.....	233	Removal and Installation.....	306
Locations of Needle Bearings, Thrust Washers and Snap Rings.....	234	SERVICE DATA AND SPECIFICATIONS (SDS).....	307
DISASSEMBLY.....	235	General Specifications.....	307
REPAIR FOR COMPONENT PARTS.....	246	Shift Schedule.....	307
Oil Pump.....	246	Stall Revolution.....	307
Control Valve Assembly.....	250	Line Pressure.....	307
Control Valve Upper Body.....	256	Return Springs.....	308
Control Valve Lower Body.....	261	Accumulator O-ring.....	309
Reverse Clutch.....	263	Clutches and Brakes.....	309
High Clutch.....	267	Oil Pump and Low One-way Clutch.....	311
Forward and Overrun Clutches.....	269	Total End Play.....	311
Low & Reverse Brake.....	273	Reverse Clutch Drum End Play.....	312
		Removal and Installation.....	312

CI

MA

EM

LC

EC

FE

CL

MT

AT

TF

PD

AX

SU

BR

ST

RS

BT

PA

SC

EL

IDX

TROUBLE DIAGNOSIS — INDEX

Alphabetical & P No. Index for DTC

Alphabetical & P No. Index for DTC

NAAT0179

ALPHABETICAL INDEX FOR DTC

NAAT0179S01

Items (CONSULT screen terms)	DTC		Reference page
	ECM*1	CONSULT GST*2	
A/T 1ST GR FNCTN	1103	P0731	AT-105
A/T 2ND GR FNCTN	1104	P0732	AT-111
A/T 3RD GR FNCTN	1105	P0733	AT-117
A/T 4TH GR FNCTN	1106	P0734	AT-123
A/T TCC S/V FNCTN	1107	P0744	AT-137
ENGINE SPEED SIG*4	1207	P0725	AT-101
ATF TEMP SEN/CIRC	1208	P0710	AT-91
INHIBITOR SW/CIRC	1101	P0705	AT-86
L/PRESS SOL/CIRC	1205	P0745	AT-145
O/R CLTCH SOL/CIRC	1203	P1760	AT-168
SFT SOL A/CIRC*3	1108	P0750	AT-151
SFT SOL B/CIRC*3	1201	P0755	AT-156
TP SEN/CIRC A/T*3	1206	P1705	AT-161
TCC SOLENOID/CIRC	1204	P0740	AT-132
VEH SPD SEN/CIR AT*4	1102	P0720	AT-96

*1: In Diagnostic Test Mode II (Self-diagnostic results), these numbers are controlled by NISSAN.

*2: These numbers are prescribed by SAE J2012.

*3: When the fail-safe operation occurs, the MIL illuminates.

*4: The MIL illuminates after TCM enters the fail-safe mode in two consecutive trips, if both the "Revolution sensor" and the "Engine speed signal" meet the fail-safe condition at the same time.

TROUBLE DIAGNOSIS — INDEX

Alphabetical & P No. Index for DTC (Cont'd)

P NO. INDEX FOR DTC

-NAAT0179S02

DTC		Items (CONSULT screen terms)	Reference page
CONSULT GST*2	ECM*1		
P0705	1101	INHIBITOR SW/CIRC	AT-86
P0710	1208	ATF TEMP SEN/CIRC	AT-91
P0720	1102	VEH SPD SEN/CIR AT*4	AT-96
P0725	1207	ENGINE SPEED SIG*4	AT-101
P0731	1103	A/T 1ST GR FNCTN	AT-105
P0732	1104	A/T 2ND GR FNCTN	AT-111
P0733	1105	A/T 3RD GR FNCTN	AT-117
P0734	1106	A/T 4TH GR FNCTN	AT-123
P0740	1204	TCC SOLENOID/CIRC	AT-132
P0744	1107	A/T TCC S/V FNCTN	AT-137
P0745	1205	L/PRESS SOL/CIRC	AT-145
P0750	1108	SFT SOL A/CIRC*3	AT-151
P0755	1201	SFT SOL B/CIRC*3	AT-156
P1705	1206	TP SEN/CIRC A/T*3	AT-161
P1760	1203	O/R CLTCH SOL/CIRC	AT-168

*1: In Diagnostic Test Mode II (Self-diagnostic results), these numbers are controlled by NISSAN.

*2: These numbers are prescribed by SAE J2012.

*3: When the fail-safe operation occurs, the MIL illuminates.

*4: The MIL illuminates after TCM enters the fail-safe mode in two consecutive trips, if both the "Revolution sensor" and the "Engine speed signal" meet the fail-safe condition at the same time.

PRECAUTIONS

Precautions for Supplemental Restraint System (SRS) "AIR BAG"

Precautions for Supplemental Restraint System (SRS) "AIR BAG"

NAAT0001

The Supplemental Restraint System "AIR BAG", used along with a seat belt, helps to reduce the risk or severity of injury to the driver and front passenger in a frontal collision. The Supplemental Restraint System consists of air bag modules (located in the center of the steering wheel and on the instrument panel on the passenger side), a diagnosis sensor unit, warning lamp, wiring harness and spiral cable. Information necessary to service the system safely is included in the **RS** section of this Service Manual.

WARNING:

- To avoid rendering the SRS inoperative, which could increase the risk of personal injury or death in the event of a collision which would result in air bag inflation, all maintenance must be performed by an authorized NISSAN dealer.
- Improper maintenance, including incorrect removal and installation of the SRS, can lead to personal injury caused by unintentional activation of the system.
- Do not use electrical test equipment on any circuit related to the SRS unless instructed to in this Service Manual. SRS wiring harnesses are covered with yellow insulation either just before the harness connectors or for the complete harness, for easy identification.

Precautions for On Board Diagnostic (OBD) System of A/T and Engine

NAAT0002

The ECM (ECCS control module) has an on board diagnostic system. It will light up the malfunction indicator lamp (MIL) to warn the driver of a malfunction causing emission deterioration.

CAUTION:

- Be sure to turn the ignition switch OFF and disconnect the negative battery terminal before any repair or inspection work. The open/short circuit of related switches, sensors, solenoid valves, etc. will cause the MIL to light up.
- Be sure to connect and lock the connectors securely after work. A loose (unlocked) connector will cause the MIL to light up due to an open circuit. (Be sure the connector is free from water, grease, dirt, bent terminals, etc.)
- Be sure to route and secure the harnesses properly after work. Interference of the harness with a bracket, etc. may cause the MIL to light up due to a short circuit.
- Be sure to connect rubber tubes properly after work. A misconnected or disconnected rubber tube may cause the MIL to light up due to a malfunction of the EGR system or fuel injection system, etc.
- Be sure to erase the unnecessary malfunction information (repairs completed) from the TCM and ECM before returning the vehicle to the customer.

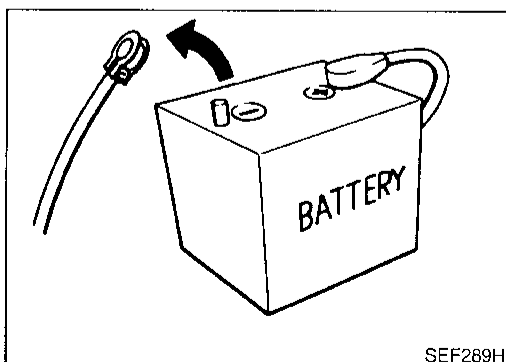

Precautions

NAAT0003

- Before connecting or disconnecting the TCM harness connector, turn ignition switch OFF and disconnect negative battery terminal. Failure to do so may damage the TCM. Because battery voltage is applied to TCM even if ignition switch is turned off.

PRECAUTIONS

Precautions (Cont'd)

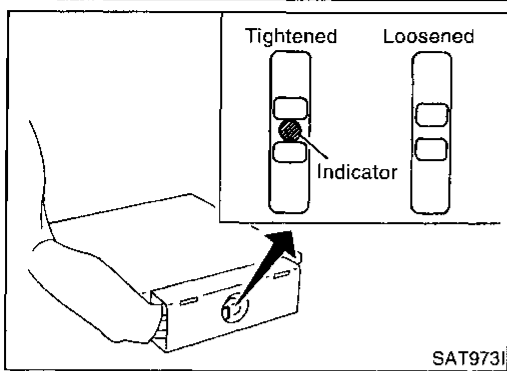

- When connecting TCM harness connector, tighten securing bolt until the orange indicator appears.
☛ : 3.0 - 5.0 N·m (0.3 - 0.5 kg·m, 26 - 43 in·lb)

GI
MA
EM
LC

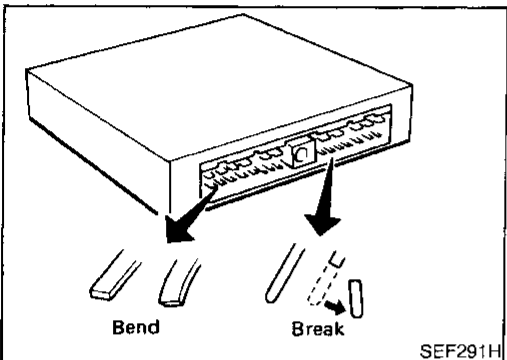

- When connecting or disconnecting pin connectors into or from TCM, take care not to damage pin terminals (bend or break).
Make sure that there are not any bends or breaks on TCM pin terminal, when connecting pin connectors.

EC
FE
CL

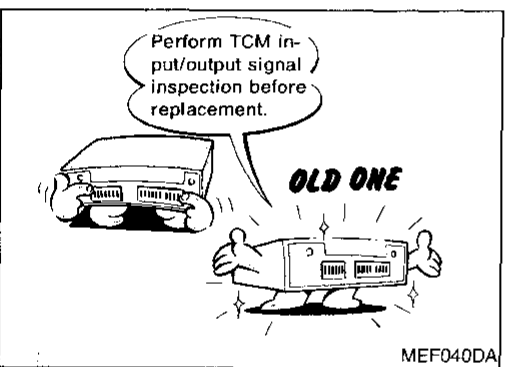

- Before replacing TCM, perform TCM input/output signal inspection and make sure whether TCM functions properly or not. (See page AT-80.)

MT
AT
TF

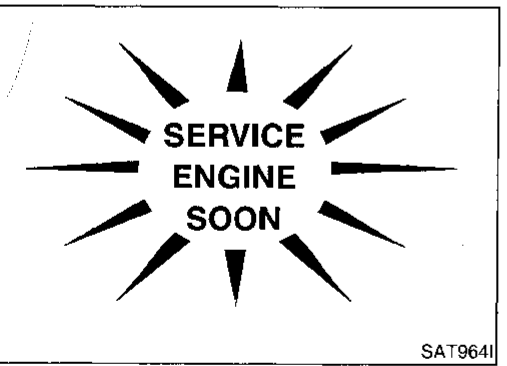

- After performing each TROUBLE DIAGNOSIS, perform "DTC (Diagnostic Trouble Code) CONFIRMATION PROCEDURE".
The DTC should not be displayed in the "DTC CONFIRMATION PROCEDURE" if the repair is completed.

PD
AX
SU
BR
ST

- Before proceeding with disassembly, thoroughly clean the outside of the transaxle. It is important to prevent the internal parts from becoming contaminated by dirt or other foreign matter.
- Disassembly should be done in a clean work area.
- Use lint-free cloth or towels for wiping parts clean. Common shop rags can leave fibers that could interfere with the operation of the transaxle.
- Place disassembled parts in order for easier and proper assembly.
- All parts should be carefully cleaned with a general purpose, non-flammable solvent before inspection or reassembly.

RS
BT
HA
SC
EL
IDX

PRECAUTIONS

Precautions (Cont'd)

- Gaskets, seals and O-rings should be replaced any time the transaxle is disassembled.
- It is very important to perform functional tests whenever they are indicated.
- The valve body contains precision parts and requires extreme care when parts are removed and serviced. Place disassembled valve body parts in order for easier and proper assembly. Care will also prevent springs and small parts from becoming scattered or lost.
- Properly installed valves, sleeves, plugs, etc. will slide along bores in valve body under their own weight.
- Before assembly, apply a coat of recommended ATF to all parts. Apply petroleum jelly to protect O-rings and seals, or hold bearings and washers in place during assembly. Do not use grease.
- Extreme care should be taken to avoid damage to O-rings, seals and gaskets when assembling.
- Replace ATF cooler if excessive foreign material is found in oil pan or clogging strainer. Refer to "ATF COOLER SERVICE" (Refer to AT-7).
- After overhaul, refill the transmission with new ATF.
- When the A/T drain plug is removed, only some of the fluid is drained. Old A/T fluid will remain in torque converter and ATF cooling system.
Always follow the procedures under "Changing A/T Fluid" in the MA section when changing A/T fluid.

Service Notice or Precautions

NAAT0004

FAIL-SAFE

NAAT0004S01

The TCM has an electronic Fail-Safe (limp home mode). This allows the vehicle to be driven even if a major electrical input/output device circuit is damaged.

Under Fail-Safe, the vehicle always runs in third gear, even with a shift lever position of "1", "2" or "D". The customer may complain of sluggish or poor acceleration.

When the ignition key is turned "ON" following Fail-Safe operation, O/D OFF indicator lamp blinks for about 8 seconds. (For "TCM SELF-DIAGNOSTIC PROCEDURE (No Tools)", refer to AT-44.)

Fail-Safe may occur without electrical circuit damage if the vehicle is driven under extreme conditions (such as excessive wheel spin followed by sudden braking). To recover normal shift pattern, turn the ignition key "OFF" for 5 seconds, then "ON".

The blinking of the O/D OFF indicator lamp for about 8 seconds will appear only once and be cleared. The customer may resume normal driving conditions.

Always follow the "WORK FLOW" (Refer to AT-52).

The SELF-DIAGNOSIS results will be as follows:

The first SELF-DIAGNOSIS will indicate damage to the vehicle speed sensor or the revolution sensor.

During the next SELF-DIAGNOSIS, performed after checking the sensor, no damages will be indicated.

TORQUE CONVERTER SERVICE

NAAT0004S04

The torque converter should be replaced under any of the following conditions:

- External leaks in the hub weld area.
- Converter hub is scored or damaged.
- Converter pilot is broken, damaged or fits poorly into crankshaft.

PRECAUTIONS

Service Notice or Precautions (Cont'd)

- Steel particles are found after flushing the cooler and cooler lines. GI
- Pump is damaged or steel particles are found in the converter. MA
- Vehicle has TCC shudder and/or no TCC apply. Replace only after all hydraulic and electrical diagnoses have been made. (Converter clutch material may be glazed.) EM
- Converter is contaminated with engine coolant containing antifreeze. LC
- Internal failure of stator roller clutch. EC
- Heavy clutch debris due to overheating (blue converter). FE
- Steel particles or clutch lining material found in fluid filter or on magnet when no internal parts in unit are worn or damaged — indicates that lining material came from converter. CL

The torque converter should not be replaced if:

- The oil has an odor, is discolored, and there is no evidence of metal or clutch facing particles. MT
- The threads in one or more of the converter bolt holes are damaged. AT
- Transaxle failure did not display evidence of damaged or worn internal parts, steel particles or clutch plate lining material in unit and inside the fluid filter. TF
- Vehicle has been exposed to high mileage (only). The exception may be where the torque converter clutch dampener plate lining has seen excess wear by vehicles operated in heavy and/or constant traffic, such as taxi, delivery or police use. PD

ATF COOLER SERVICE

NAAAT0004S02

Replace ATF cooler if excessive foreign material is found in oil pan or clogging strainer.

Replace radiator lower tank (which includes ATF cooler) with a new one and flush cooler line using cleaning solvent and compressed air.

OBD-II SELF-DIAGNOSIS

NAAAT0004S03

- A/T self-diagnosis is performed by the TCM in combination with the ECM. The results can be read through the blinking pattern of the O/D OFF indicator or the malfunction indicator lamp (MIL). Refer to the table on AT-36 for the indicator used to display each self-diagnostic result. AX
- The self-diagnostic results indicated by the MIL are automatically stored in both the ECM and TCM memories. SU
- **Always perform the procedure "HOW TO ERASE DTC" on AT-33 to complete the repair and avoid unnecessary blinking of the MIL.** BR
- The following self-diagnostic items can be detected using ECM self-diagnostic results mode* only when the O/D OFF indicator lamp does not indicate any malfunctions.
 - Inhibitor switch
 - A/T 1st, 2nd, 3rd, or 4th gear function
 - A/T TCC S/V function (lock-up)

*: For details of OBD-II, refer to EC section ("ON BOARD DIAGNOSTIC SYSTEM DESCRIPTION").

Wiring Diagrams and Trouble Diagnosis

NAAAT0005

When you read wiring diagrams, refer to the followings: ST

- "HOW TO READ WIRING DIAGRAMS" in GI section
- "POWER SUPPLY ROUTING" for power distribution circuit in EL section

When you perform trouble diagnosis, refer to the followings: RS

- "HOW TO FOLLOW TEST GROUP IN TROUBLE DIAGNOSIS" in GI section
- "HOW TO PERFORM EFFICIENT DIAGNOSIS FOR AN ELECTRICAL INCIDENT" in GI section

HA

SC

EL

IDX

PREPARATION

Special Service Tools

Special Service Tools

NAAT0006

The actual shapes of Kent-Moore tools may differ from those of special service tools illustrated here.

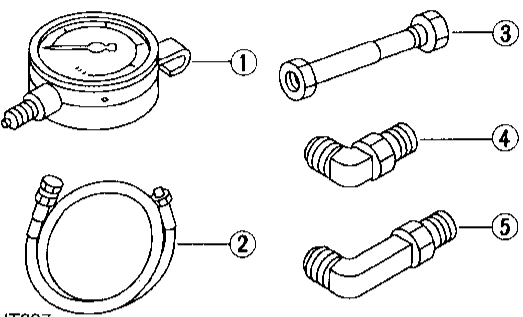
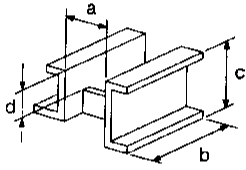
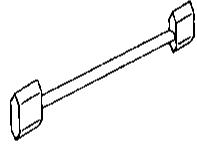
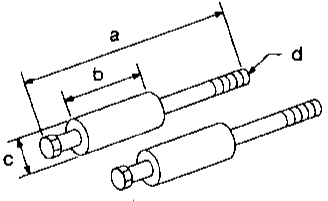
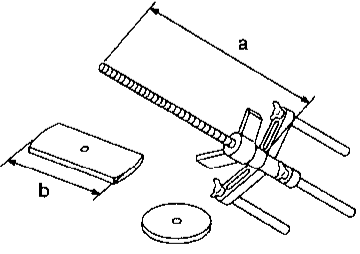
Tool number (Kent-Moore No.) Tool name	Description
<p>ST2505S001 (J34301-C) Oil pressure gauge set 1 ST25051001 (—) Oil pressure gauge 2 ST25052000 (—) Hose 3 ST25053000 (—) Joint pipe 4 ST25054000 (—) Adapter 5 ST25055000 (—) Adapter</p>	<p>Measuring line pressure.</p>  <p>NT097</p>
<p>ST07870000 (J37068) Transmission case stand</p>	<p>Disassembling and assembling A/T a: 182 mm (7.17 in) b: 282 mm (11.10 in) c: 230 mm (9.06 in) d: 100 mm (3.94 in)</p>  <p>NT421</p>
<p>KV31102100 (J37065) Torque converter one-way clutch check tool</p>	<p>Checking one-way clutch in torque converter</p>  <p>NT098</p>
<p>ST25850000 (J25721-A) Sliding hammer</p>	<p>Removing oil pump assembly a: 179 mm (7.05 in) b: 70 mm (2.76 in) c: 40 mm (1.57 in) dia. d: M12 x 1.75P</p>  <p>NT422</p>
<p>KV31102400 (J34285 and J34285-87) Clutch spring compressor</p>	<p>Removing and installing clutch return springs a: 320 mm (12.60 in) b: 174 mm (6.85 in)</p>  <p>NT423</p>

PREPARATION

Special Service Tools (Cont'd)

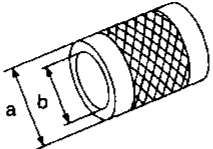
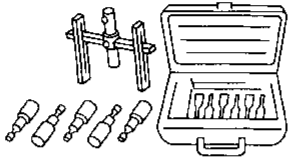
Tool number (Kent-Moore No.) Tool name	Description	
ST33200000 (J26082) Drift	 <p data-bbox="980 243 1484 359">Installing oil pump housing oil seal Installing rear oil seal a: 60 mm (2.36 in) dia. b: 44.5 mm (1.752 in) dia.</p> <p data-bbox="444 422 505 443">NT091</p>	<p>CI</p> <p>MA</p> <p>EM</p> <p>LC</p>
(J34291) Shim setting gauge set	 <p data-bbox="980 459 1446 516">Selecting oil pump cover bearing race and oil pump thrust washer</p> <p data-bbox="444 642 505 663">NT101</p>	<p>EC</p> <p>FE</p> <p>GL</p>

MT

AT

TF

PD

AX

SU

BR

ST

RS

BT

HA

SC

EL

IDX

OVERALL SYSTEM

A/T Electrical Parts Location

NAAT0007

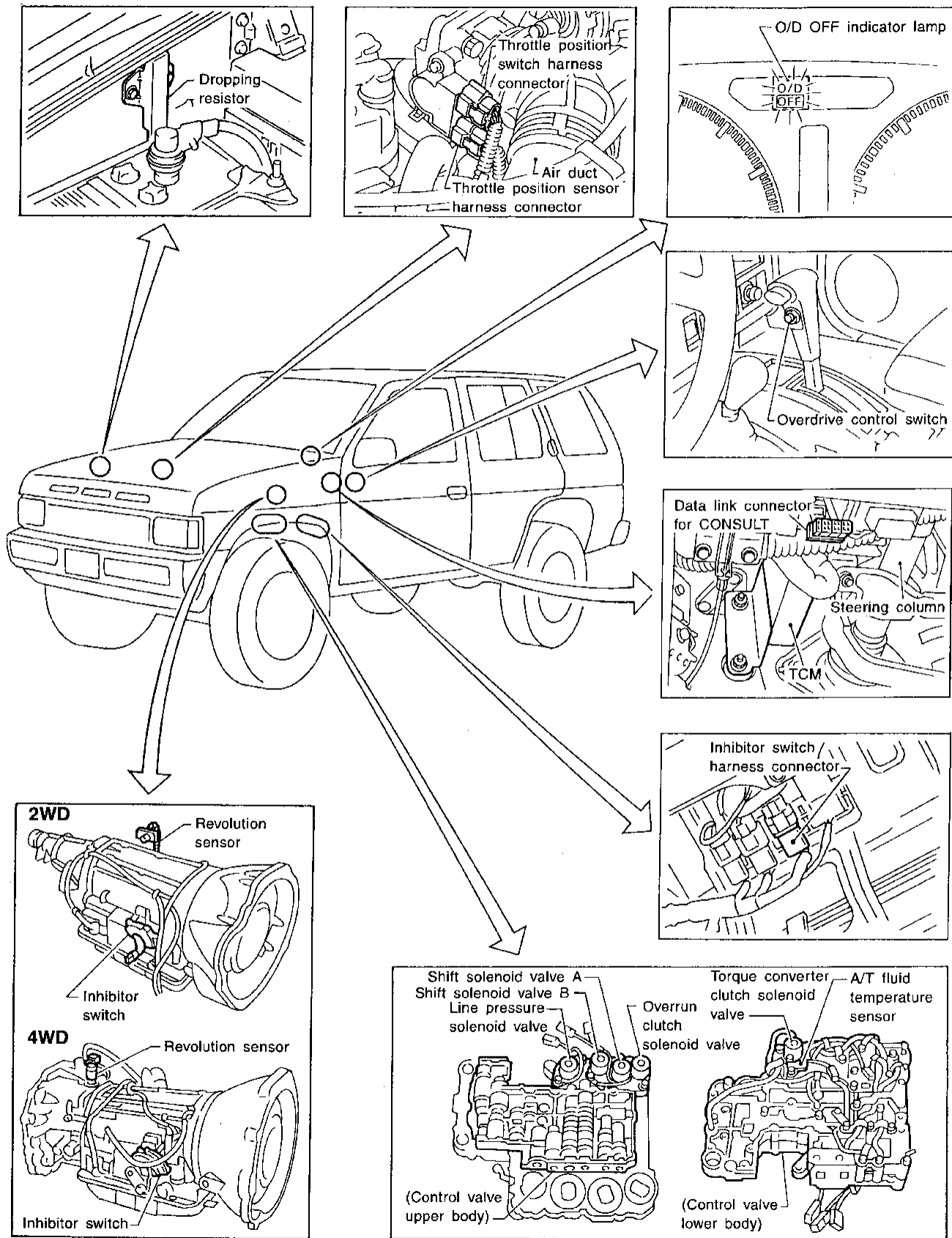

SAT202J

Circuit Diagram

NAAT0009

GI

MA

EM

LC

EC

FE

CL

MT

AT

TF

PD

AX

SU

BR

ST

RS

BT

HA

SC

EL

IDX

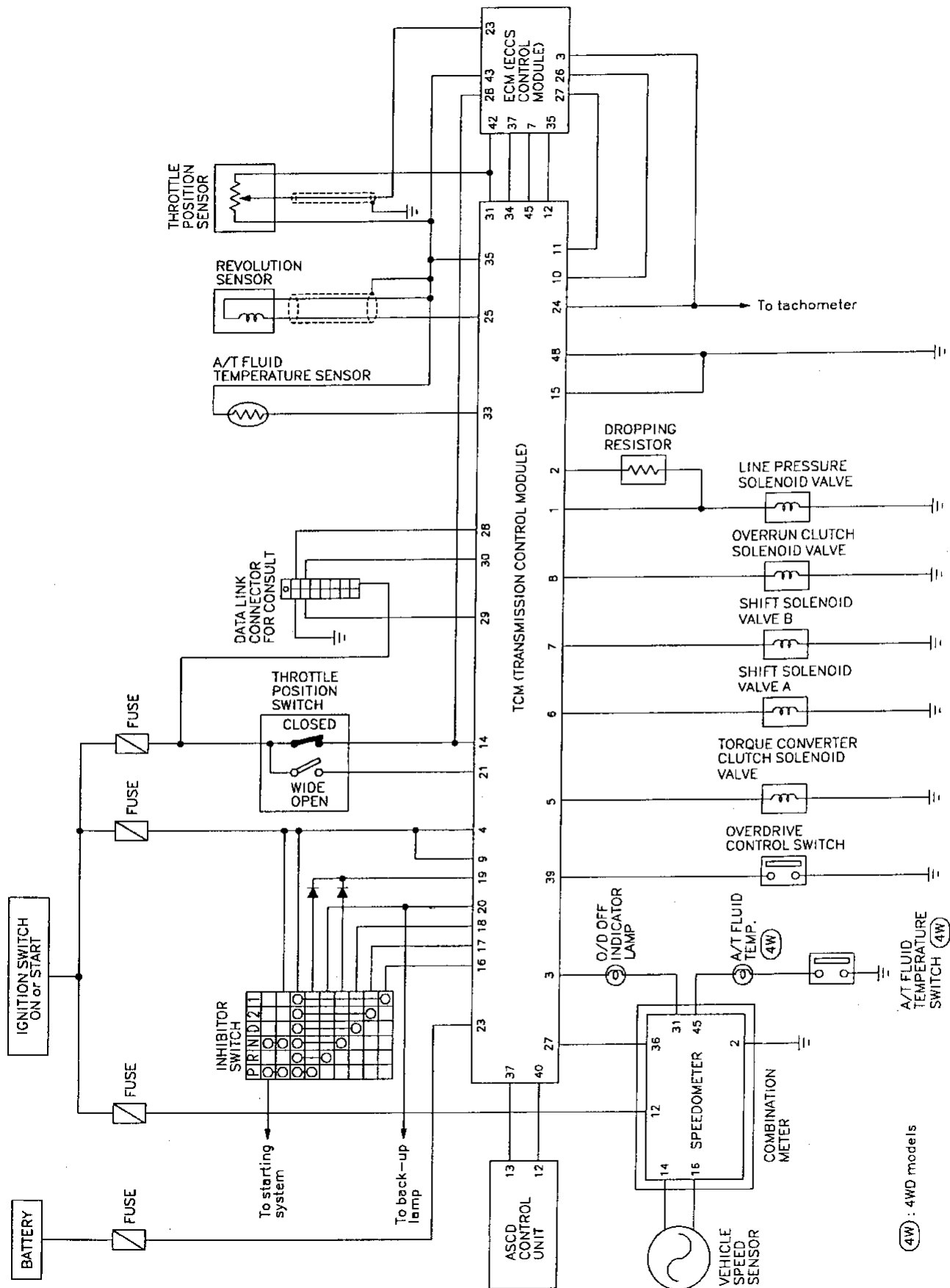

(4W) : 4WD models

MAT552A

OVERALL SYSTEM

Cross-sectional View

Cross-sectional View

NAAT0010

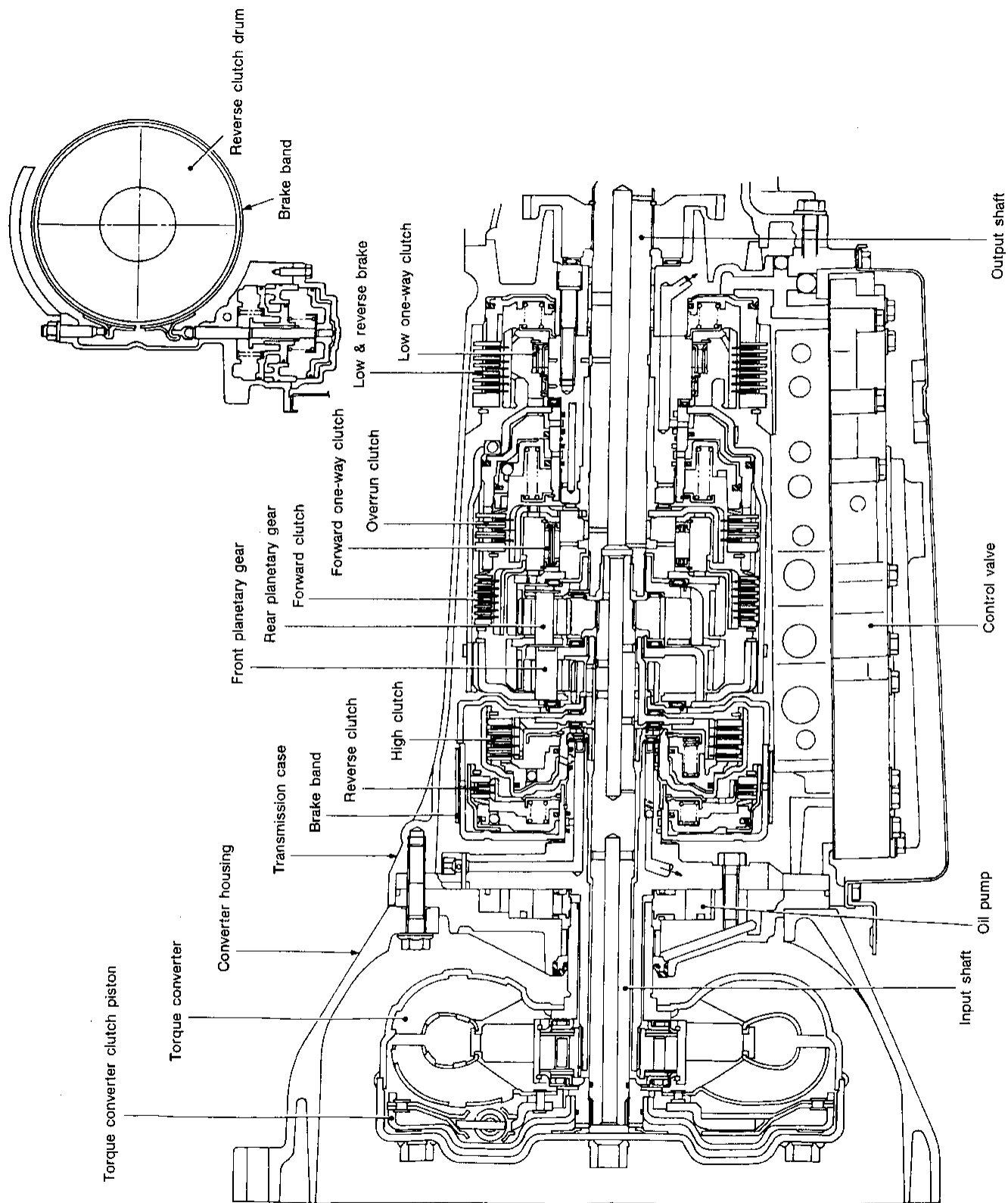

SAT125BA

Hydraulic Control Circuit

NAAT0011

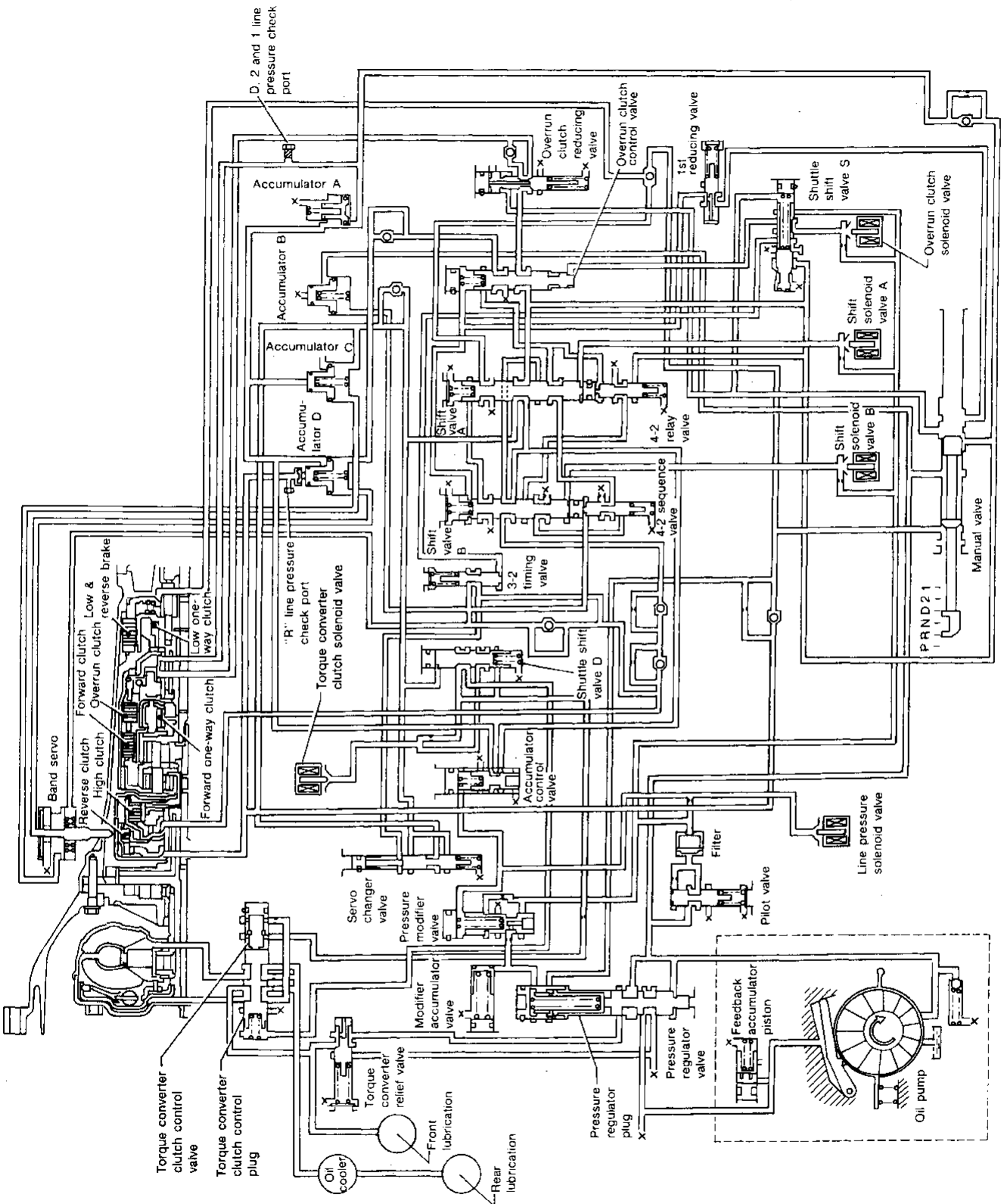

GI
MA
EM
LC
EC
FE
CL
MT
AT
TF
PD
AX
SU
BR
ST
RS
BT
HA
SC
EL
IDX

SAT624GA

OVERALL SYSTEM

Shift Mechanism

NAAT0012

The automatic transmission uses compact, dual planetary gear systems to improve power-transmission efficiency, simplify construction and reduce weight.

It also employs an optimum shift control and superwide gear ratios. They improve starting performance and acceleration during medium and high-speed operation.

Two one-way clutches are also employed: one is used for the forward clutch and the other for the low clutch. These one-way clutches, combined with four accumulators, reduce shifting shock to a minimum.

CONSTRUCTION

NAAT0012S01

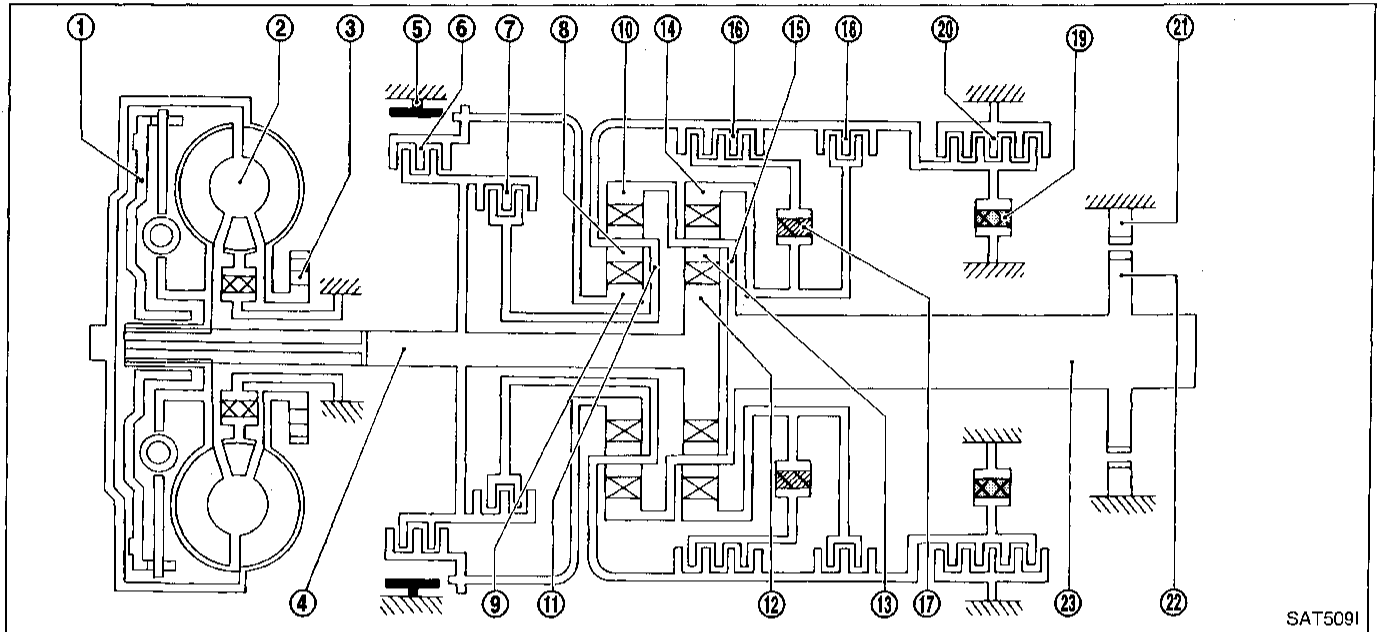

SAT509I

- | | | |
|-----------------------------------|-----------------------------|----------------------------|
| 1. Torque converter clutch piston | 9. Front sun gear | 17. Forward one-way clutch |
| 2. Torque converter | 10. Front internal gear | 18. Overrun clutch |
| 3. Oil pump | 11. Front planetary carrier | 19. Low one-way clutch |
| 4. Input shaft | 12. Rear sun gear | 20. Low & reverse brake |
| 5. Brake band | 13. Rear pinion gear | 21. Parking pawl |
| 6. Reverse clutch | 14. Rear internal gear | 22. Parking gear |
| 7. High clutch | 15. Rear planetary carrier | 23. Output shaft |
| 8. Front pinion gear | 16. Forward clutch | |

POWER TRANSMISSION

"N" and "P" Positions

--NAAT0012S04

NAAT0012S0401

- "N" position
No control members operate. Power from the input shaft is not transmitted to the output shaft since the clutch does not operate.
- "P" position
Similar to the "N" position, no control members operate. The parking pawl interconnected with the select lever engages with the parking gear to mechanically hold the output shaft so that the power train is locked.

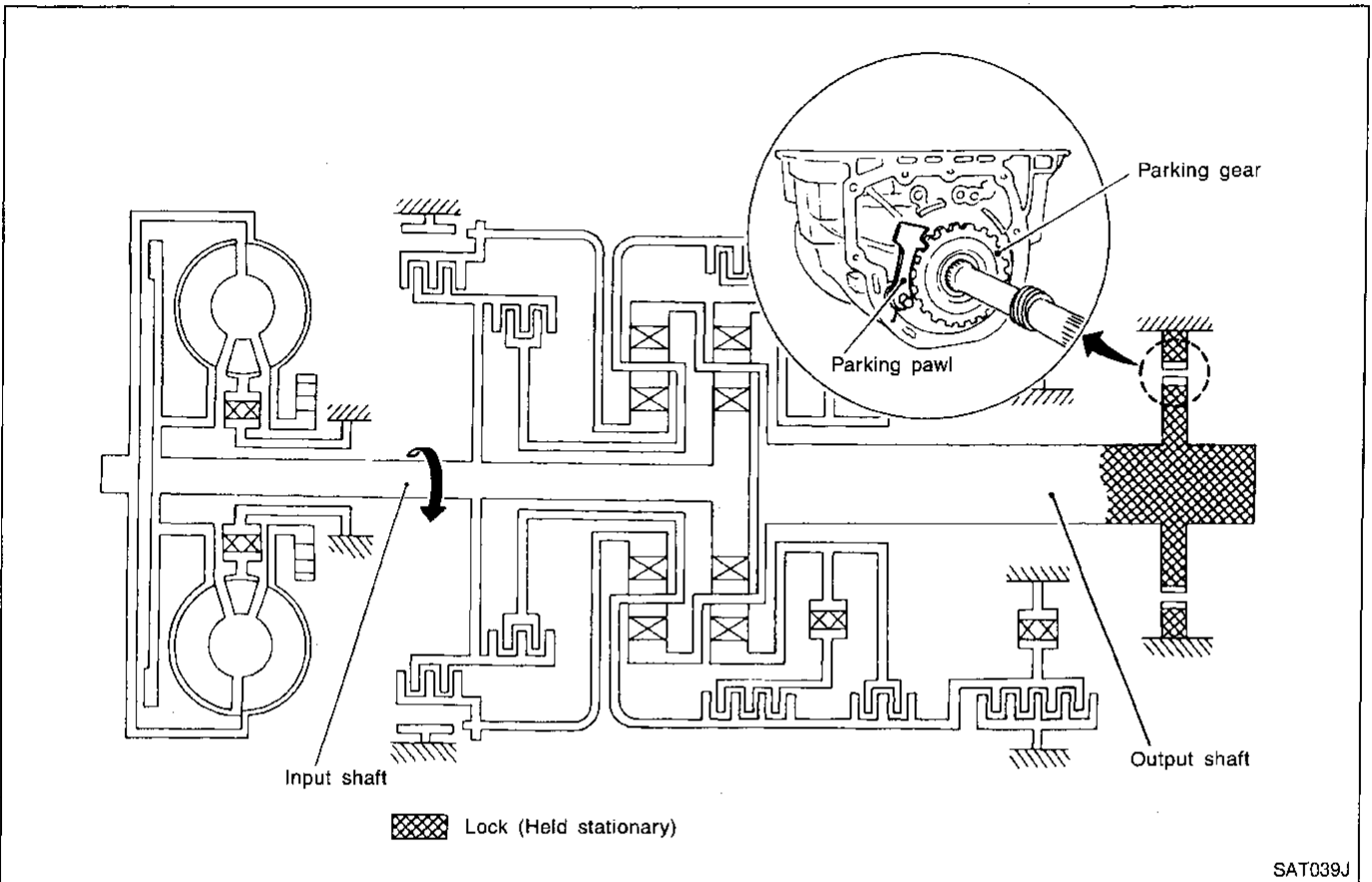

GI
MA
EM
LC
EC
FE
CL
MT
AT
TF
PD
AX
SU
BR
ST
RS
BT
HA
SC
EL
IDX

OVERALL SYSTEM

Shift Mechanism (Cont'd)

=NAAT0012S0406

"1," Position

<p>Forward clutch Forward one-way clutch Overrun clutch Low and reverse brake</p>	<p>As overrun clutch engages, rear internal gear is locked by the operation of low and reverse brake. This is different from that of D_1 and 2_1.</p>
<p>Engine brake</p>	<p>Overrun clutch always engages, therefore engine brake can be obtained when decelerating.</p>

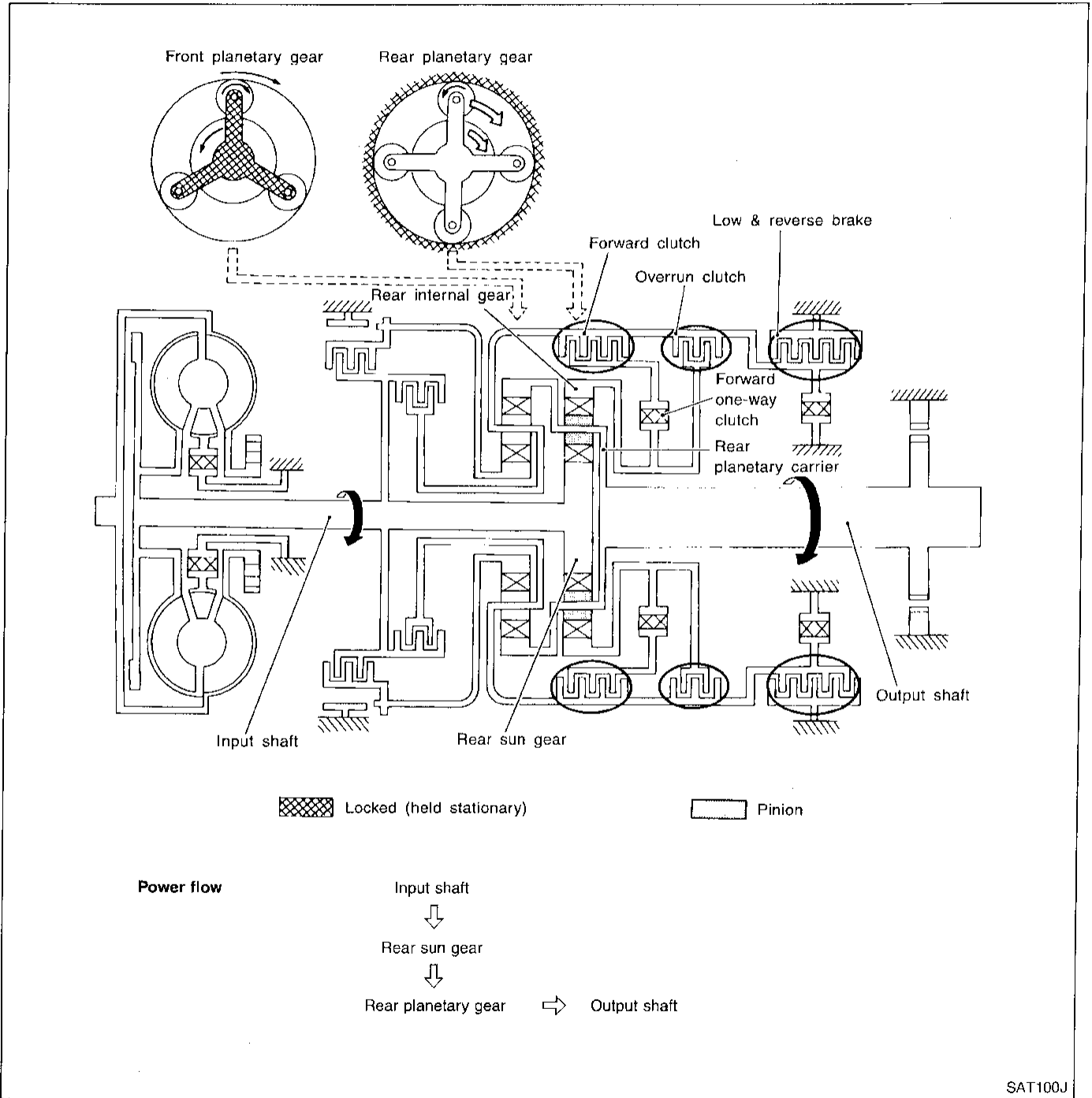

SAT100J

OVERALL SYSTEM

Shift Mechanism (Cont'd)

"D₁" and "2₁" Positions

-NAAT0012SD402

GI
MA
EM
LC
EC
FE
CL
MT
AT
TF
PD
AX
SU
BR
ST
RS
BT
HA
SC
EL
IDX

<p>Forward one-way clutch Forward clutch Low one-way clutch</p>	<p>Rear internal gear is locked to rotate counterclockwise because of the functioning of these three clutches. (Start-up at D₁)</p>
<p>Overrun clutch engagement conditions (Engine brake)</p>	<p>D₁: Overdrive control switch in "OFF" Throttle opening less than 3/16 2₁: Throttle opening less than 3/16 At D₁ and 2₁ positions, engine brake is not activated due to free turning of low one-way clutch.</p>

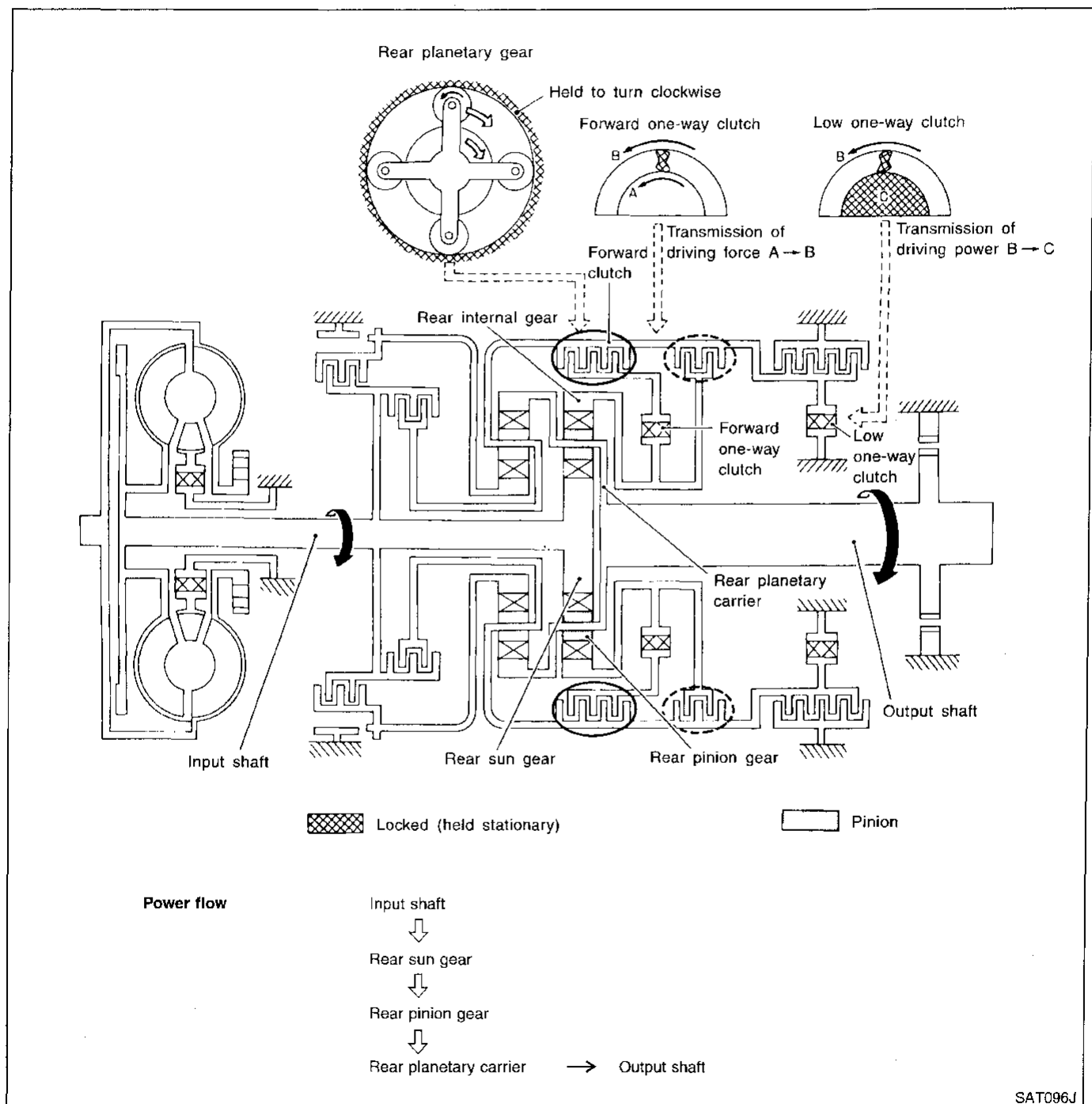

SAT096J

OVERALL SYSTEM

Shift Mechanism (Cont'd)

"D₂", "2₂" and "1₂" Positions

-NAAT0012S0403

<p>Forward clutch Forward one-way clutch Brake band</p>	<p>Rear sun gear drives rear planetary carrier and combined front internal gear. Front internal gear now rotates around front sun gear accompanying front planetary carrier. As front planetary carrier transfers the power to rear internal gear through forward clutch and forward one-way clutch, this rotation of rear internal gear increases the speed of rear planetary carrier compared with that of the 1st speed.</p>
<p>Overrun clutch engagement conditions</p>	<p>D₂: Overdrive control switch in "OFF" Throttle opening less than 3/16 2₂: Throttle opening less than 3/16 1₂: Always engaged</p>

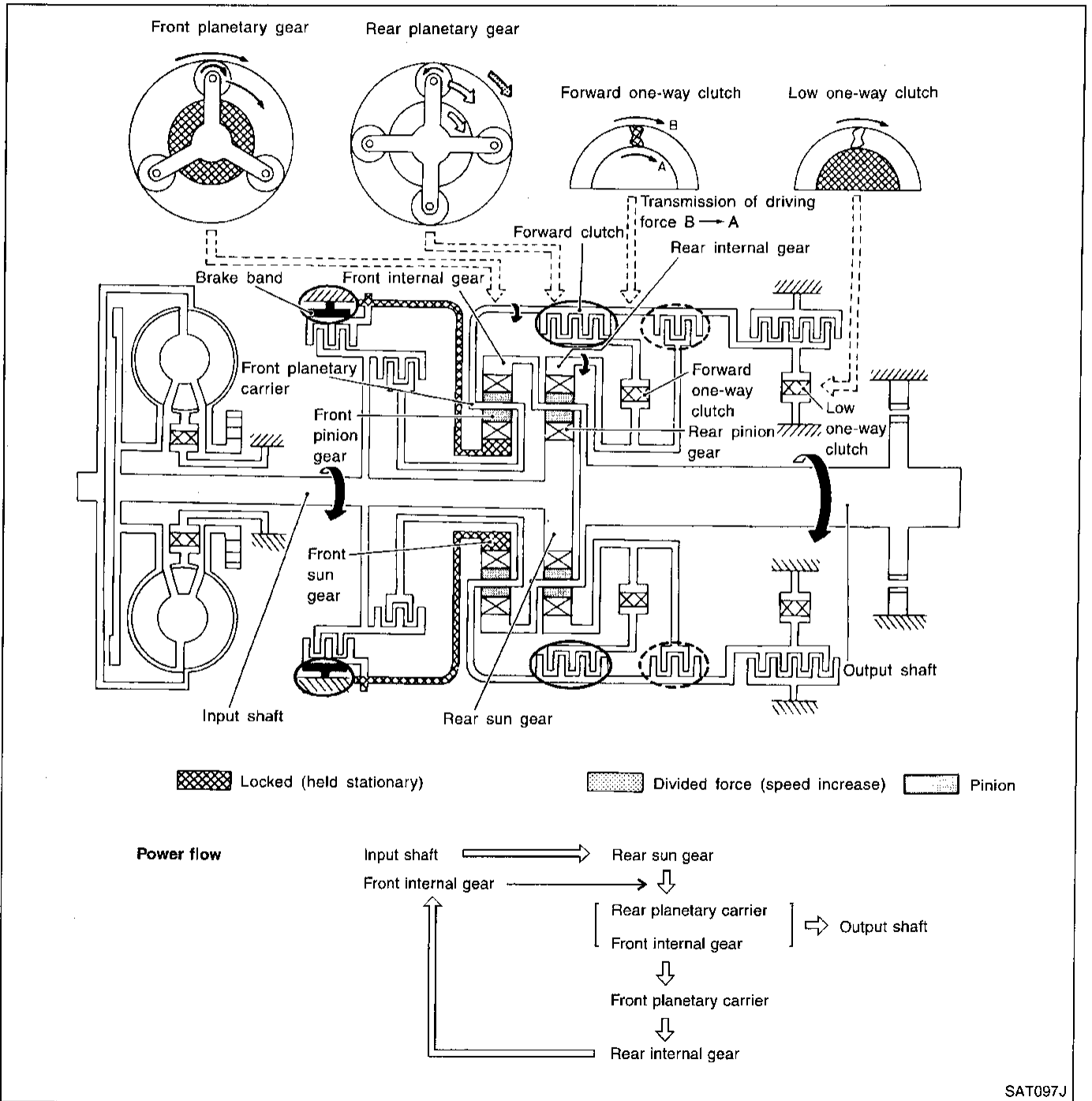

SAT097J

OVERALL SYSTEM

Shift Mechanism (Cont'd)

"D₃" Position

-NAAT0012S0404

<p>High clutch Forward clutch Forward one-way clutch</p>	<p>Input power is transmitted to front planetary carrier through high clutch. And front planetary carrier is connected to rear internal gear by operation of forward clutch and forward one-way clutch. This rear internal gear rotation and another input (the rear sun gear) accompany rear planetary carrier to turn at the same speed.</p>
<p>Overrun clutch engagement conditions</p>	<p>D₃: Overdrive control switch in "OFF" Throttle opening less than 3/16</p>

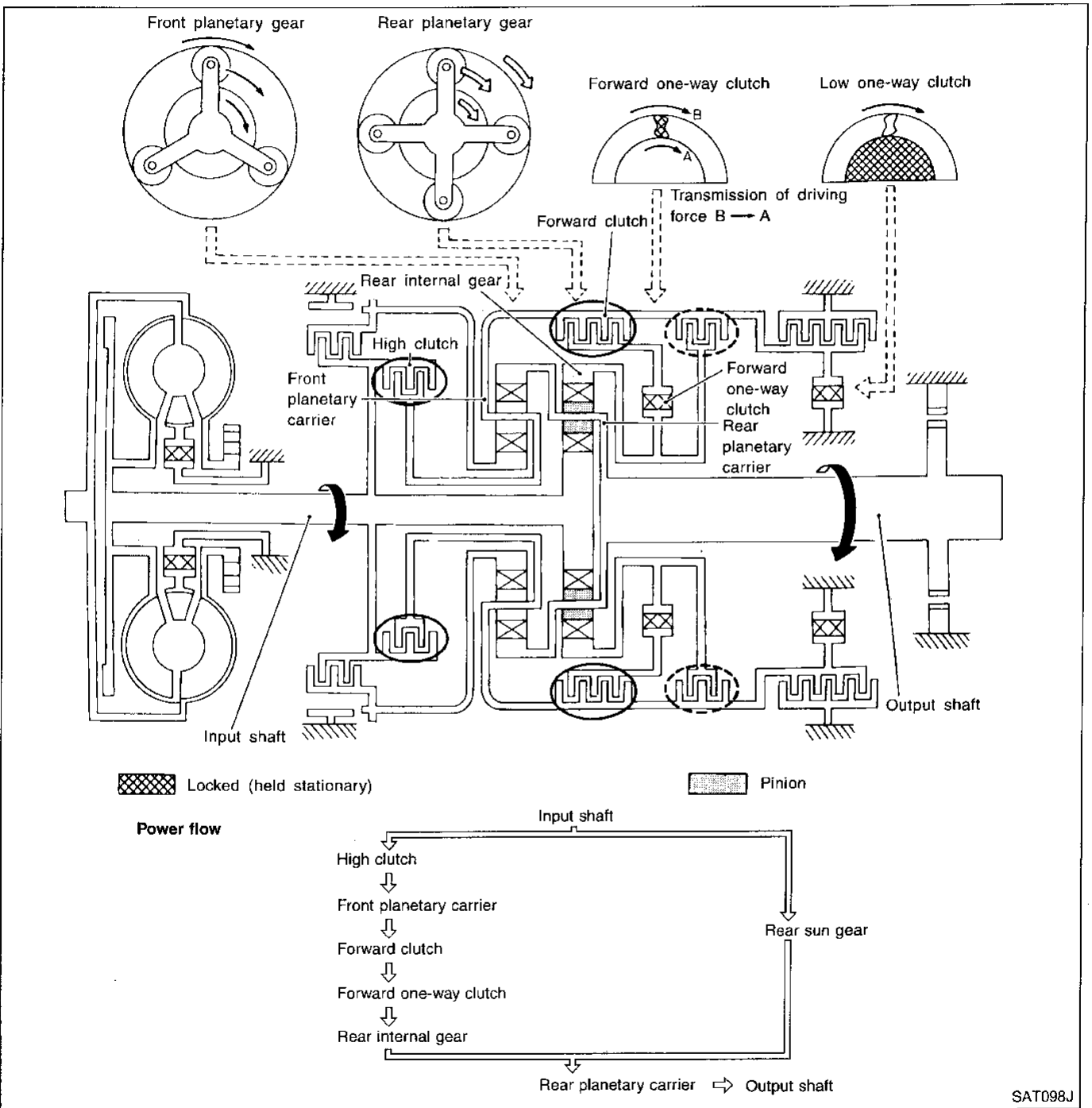

OVERALL SYSTEM

Shift Mechanism (Cont'd)

"D₄" (OD) Position

-NAA10012SD405

<p>High clutch Brake band Forward clutch (Does not affect power transmission)</p>	<p>Input power is transmitted to front carrier through high clutch. This front planetary carrier turns around the sun gear which is fixed by brake band and makes front internal gear (output) turn faster.</p>
<p>Engine brake</p>	<p>At D₄ position, there is no one-way clutch in the power transmission line and engine brake can be obtained when decelerating.</p>

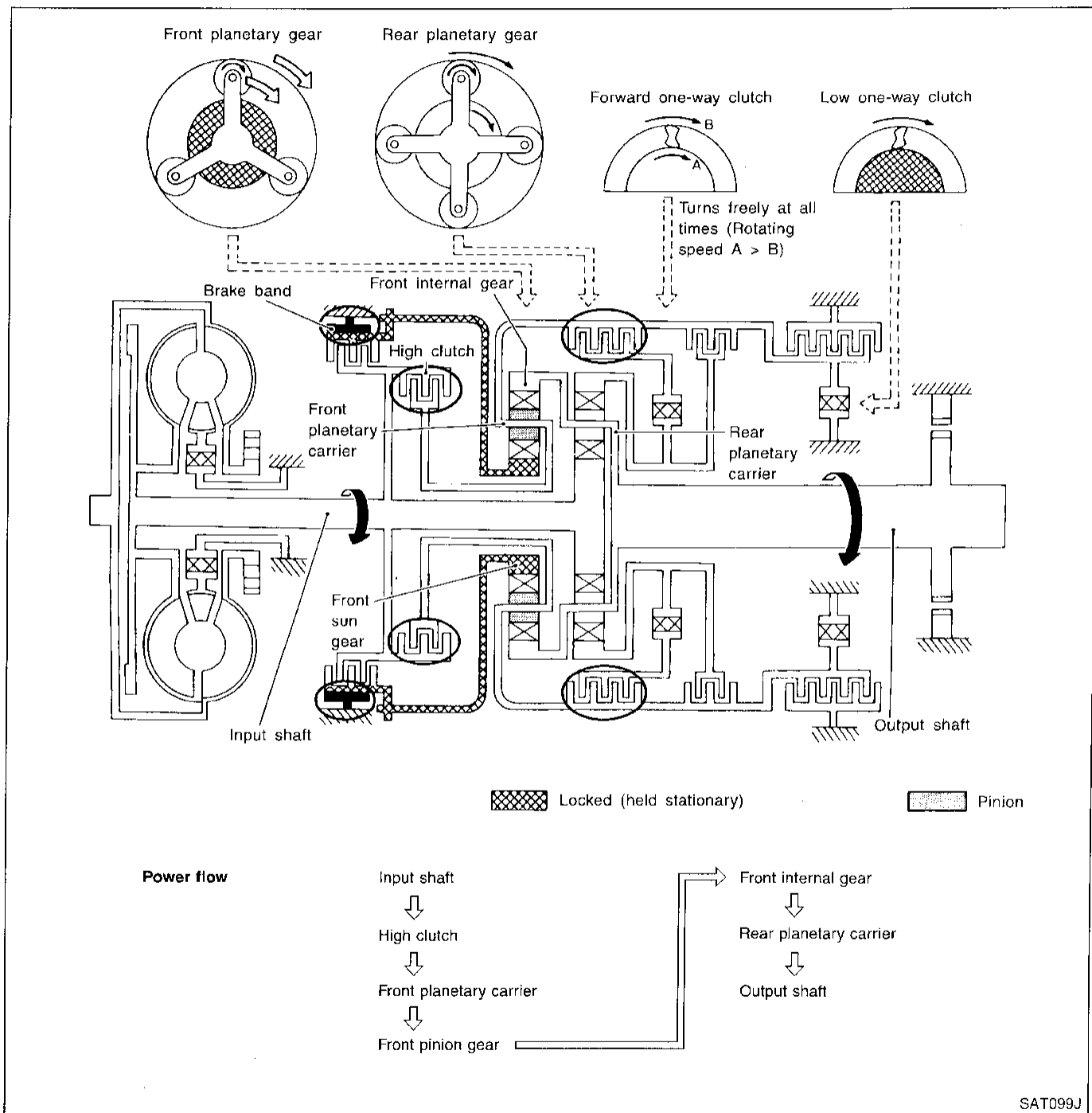

SAT099J

OVERALL SYSTEM

Shift Mechanism (Cont'd)

"R" Position

=NAAT0012S0407

<p>Reverse clutch Low and reverse brake</p>	<p>Front planetary carrier is stationary because of the operation of low and reverse brake. Input power is transmitted to front sun gear through reverse clutch, which drives front internal gear in the opposite direction.</p>
<p>Engine brake</p>	<p>As there is no one-way clutch in the power transmission line, engine brake can be obtained when decelerating.</p>

GI
MA
EM
LC
EC
FE
CL
MT
AT
TF
PD
AX
SU
BR
ST
RS
BT
HA
SC
EL
IDX

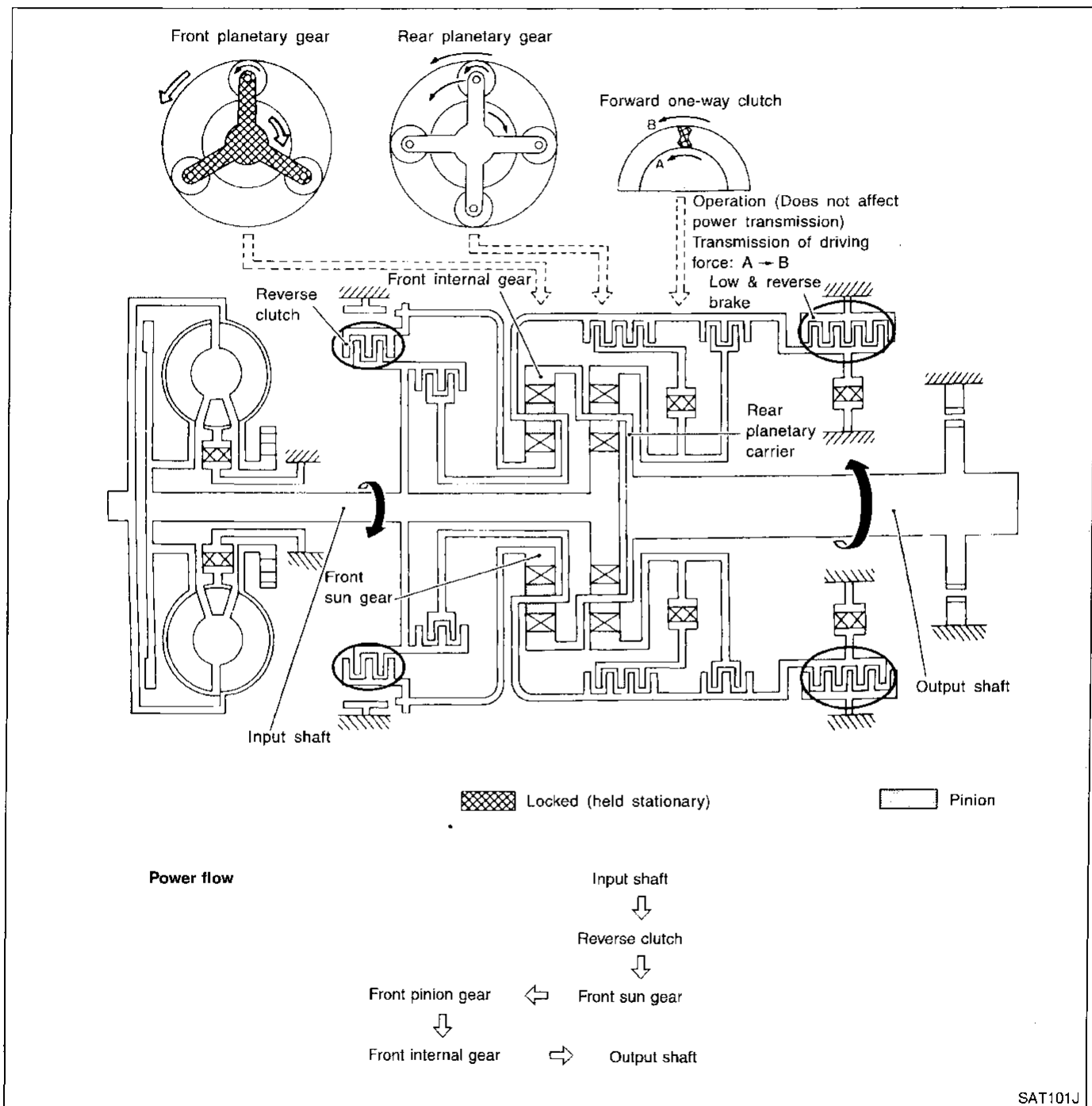

OVERALL SYSTEM

Shift Mechanism (Cont'd)

FUNCTION OF CLUTCH AND BRAKE

-NAAT0012S02

Clutch and brake components	Abbr.	Function
Reverse clutch 6	R/C	To transmit input power to front sun gear 9 .
High clutch 7	H/C	To transmit input power to front planetary carrier 11 .
Forward clutch 16	F/C	To connect front planetary carrier 11 with forward one-way clutch 17 .
Overrun clutch 18	O/C	To connect front planetary carrier 11 with rear internal gear 14 .
Brake band 5	B/B	To lock front sun gear 9 .
Forward one-way clutch 17	F/O.C	When forward clutch 16 is engaged, to stop rear internal gear 14 from rotating in opposite direction against engine revolution.
Low one-way clutch 19	L/O.C	To stop front planetary carrier 11 from rotating in opposite direction against engine revolution.
Low & reverse brake 20	L & R/B	To lock front planetary carrier 11 .

CLUTCH AND BAND CHART

NAAT0012S03

Shift position	Reverse clutch	High clutch	Forward clutch	Overrun clutch	Band servo			Forward one-way clutch	Low one-way clutch	Low & reverse brake	Lock-up	Remarks
					2nd apply	3rd release	4th apply					
P												PARK POSITION
R	○									○		REVERSE POSITION
N												NEUTRAL POSITION
D*4	1st		○	*1D				B	B			Automatic shift 1 ⇔ 2 ⇔ 3 ⇔ 4
	2nd		○	*1A	○			B				
	3rd		○	○	*1A	*2C	C	B			*5○	
	4th		○	C		*3C	C	○			○	
2	1st		○	○				B	B			Automatic shift 1 ⇔ 2
	2nd		○	○	○			B				
1	1st		○	○				B	B	○		Locks (held stationary) in 1st speed 1 ⇔ 2
	2nd		○	○	○			B				

*1: Operates when overdrive control switch is being set in "OFF" position.

*2: Oil pressure is applied to both 2nd "apply" side and 3rd "release" side of band servo piston. However, brake band does not contract because oil pressure area on the "release" side is greater than that on the "apply" side.

*3: Oil pressure is applied to 4th "apply" side in condition *2 above, and brake band contracts.

*4: A/T will not shift to 4th when overdrive control switch is set in "OFF" position.

*5: Operates when overdrive control switch is "OFF".

○ : Operates.

A: Operates when throttle opening is less than 3/16, activating engine brake.

B: Operates during "progressive" acceleration.

C: Operates but does not affect power transmission.

D: Operates when throttle opening is less than 3/16, but does not affect engine brake.

Control System

-NAAT0013

NAAT0013S01

OUTLINE

The automatic transmission senses vehicle operating conditions through various sensors. It always controls the optimum shaft position and reduces shifting and lock-up shocks.

SENSORS	CONTROL UNIT	ACTUATORS
Inhibitor switch Throttle position sensor Closed throttle position switch Wide open throttle position switch Engine speed signal A/T fluid temperature sensor Revolution sensor Vehicle speed sensor Overdrive control switch ASCD control unit	Shift control Line pressure control Lock-up control Overrun clutch control Timing control Fail-safe control Self-diagnosis CONSULT communication line Duet-EU control	Shift solenoid valve A Shift solenoid valve B Overrun clutch solenoid valve Torque converter clutch solenoid valve Line pressure solenoid valve O/D OFF indicator lamp

CONTROL SYSTEM

NAAT0013S02

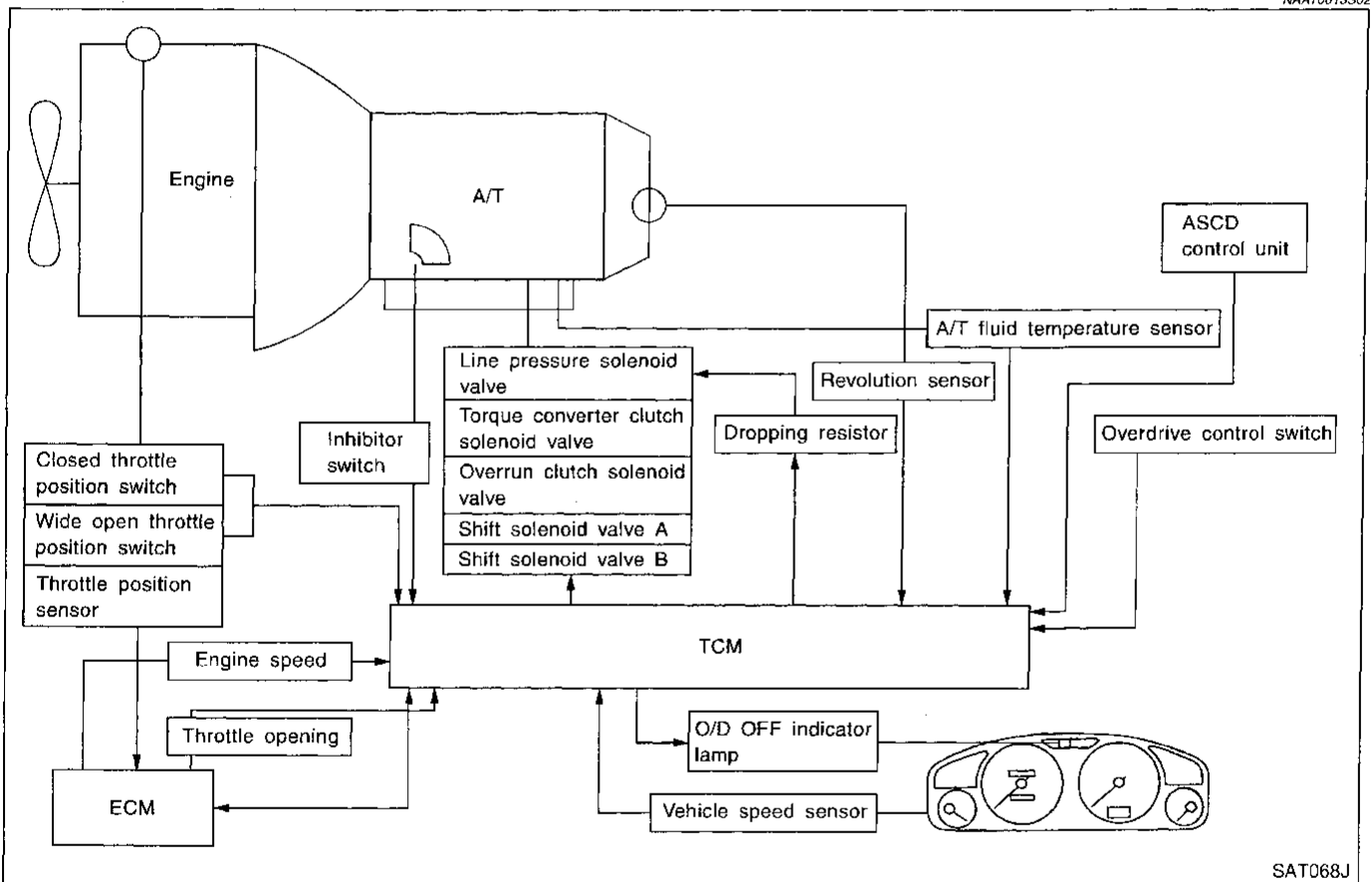

OVERALL SYSTEM

Control System (Cont'd)

TCM FUNCTION

=NAAT0013S03

The function of the TCM is to:

- Receive input signals sent from various switches and sensors.
- Determine required line pressure, shifting point, lock-up operation, and engine brake operation.
- Send required output signals to the respective solenoids.

INPUT/OUTPUT SIGNAL OF TCM

NAAT0013S04

	Sensors and solenoid valves	Function
Input	Inhibitor switch	Detects select lever position and sends a signal to TCM.
	Throttle position sensor	Detects throttle valve position and sends a signal to TCM.
	Closed throttle position switch	Detects throttle valve's fully-closed position and sends a signal to TCM.
	Wide open throttle position switch	Detects a throttle valve position of greater than 1/2 of full throttle and sends a signal to TCM.
	Engine speed signal	From ECM (ECCS control module).
	A/T fluid temperature sensor	Detects transmission fluid temperature and sends a signal to TCM.
	Revolution sensor	Detects output shaft rpm and sends a signal to TCM.
	Vehicle speed sensor	Used as an auxiliary vehicle speed sensor. Sends a signal when revolution sensor (installed on transmission) malfunctions.
	Overdrive control switch	Sends a signal, which prohibits a shift to "D ₄ " (overdrive) position, to the TCM.
	ASCD control unit	Sends the cruise signal and "D ₄ " (overdrive) cancellation signal from ASCD control unit to TCM.
Output	Shift solenoid valve A/B	Selects shifting point suited to driving conditions in relation to a signal sent from TCM.
	Line pressure solenoid valve	Regulates (or decreases) line pressure suited to driving conditions in relation to a signal sent from TCM.
	Torque converter clutch solenoid valve	Regulates (or decreases) lock-up pressure suited to driving conditions in relation to a signal sent from TCM.
	Overrun clutch solenoid valve	Controls an "engine brake" effect suited to driving conditions in relation to a signal sent from TCM.
	O/D OFF indicator lamp	Shows TCM faults, when A/T control components malfunction.

Control Mechanism

LINE PRESSURE CONTROL

NAAT0180

NAAT0180S01

TCM has the various line pressure control characteristics to meet the driving conditions.

An ON-OFF duty signal is sent to the line pressure solenoid valve based on TCM characteristics.

Hydraulic pressure on the clutch and brake is electronically controlled through the line pressure solenoid valve to accommodate engine torque. This results in smooth shift operation.

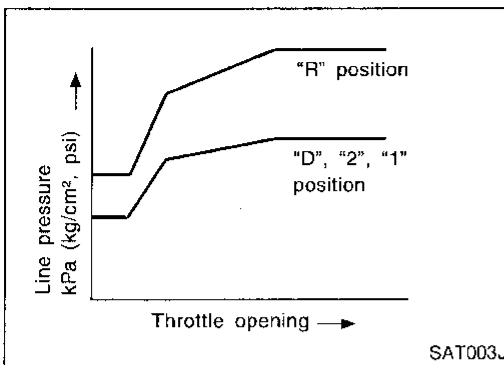

Normal Control

NAAT0180S0101

The line pressure to throttle opening characteristics is set for suitable clutch operation.

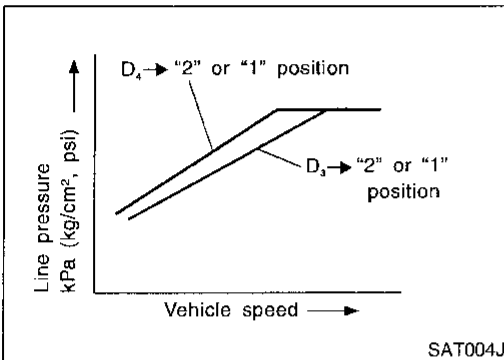

Back-up Control (Engine brake)

NAAT0180S0102

If the selector lever is shifted to "2" position while driving in D₄ (OD) or D₃, great driving force is applied to the clutch inside the transmission. Clutch operating pressure (line pressure) must be increased to deal with this driving force.

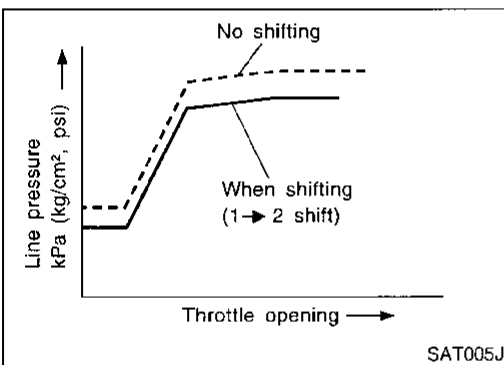

During Shift Change

NAAT0180S0103

The line pressure is temporarily reduced corresponding to a change in engine torque when shifting gears (that is, when the shift solenoid valve is switched for clutch operation) to reduce shifting shock.

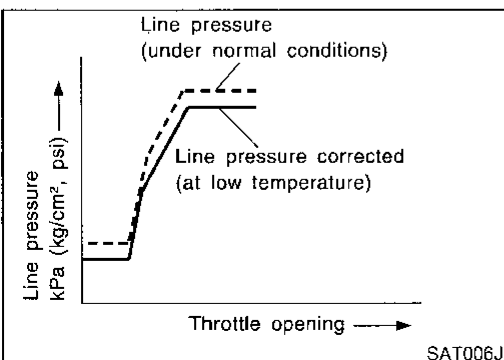

At Low Fluid Temperature

NAAT0180S0104

- Fluid viscosity and frictional characteristics of the clutch facing change with fluid temperature. Clutch engaging or band-contacting pressure is compensated for, according to fluid temperature, to stabilize shifting quality.

- The line pressure is reduced below 60°C (140°F) to prevent shifting shock due to low viscosity of automatic transmission fluid when temperature is low.

GI
MA
EM
LC
EC
FE
CL
MT
AT
TF
PD
AX
SU
BR
ST
RS
BT
HA
SC
EL
IDX

OVERALL SYSTEM

Control Mechanism (Cont'd)

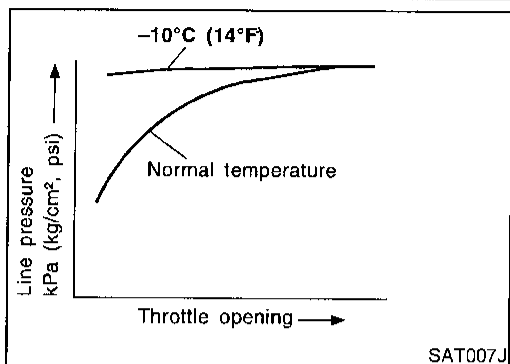

- Line pressure is increased to a maximum irrespective of the throttle opening when fluid temperature drops to -10°C (14°F). This pressure rise is adopted to prevent a delay in clutch and brake operation due to extreme drop of fluid viscosity at low temperature.

SHIFT CONTROL

NAATO180S02

The shift is regulated entirely by electronic control to accommodate vehicle speed and varying engine operations. This is accomplished by electrical signals transmitted by the revolution sensor and throttle position sensor. This results in improved acceleration performance and fuel economy.

Control of Shift Solenoid Valves A and B

NAATO180S0201

The TCM activates shift solenoid valves A and B according to signals from the throttle position sensor and revolution sensor to select the optimum gear position on the basis of the shift schedule memorized in the TCM.

The shift solenoid valve performs simple ON-OFF operation. When set to ON, the drain circuit closes and pilot pressure is applied to the shift valve.

[Relation between shift solenoid valves A and B and gear positions]

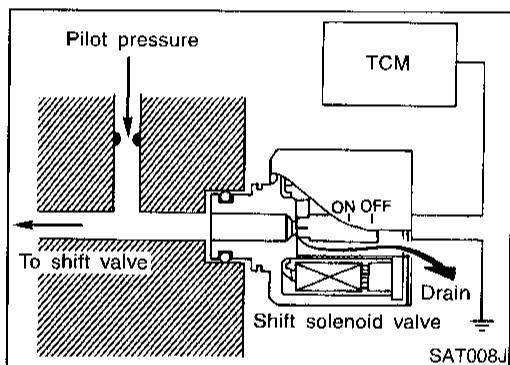

Shift solenoid valve	Gear position				
	D ₁ , 2 ₁ , 1 ₁	D ₂ , 2 ₂ , 1 ₂	D ₃	D ₄ (OD)	N-P
A	ON (Closed)	OFF (Open)	OFF (Open)	ON (Closed)	ON (Closed)
B	ON (Closed)	ON (Closed)	OFF (Open)	OFF (Open)	ON (Closed)

Control of Shift Valves A and B

NAATO180S0202

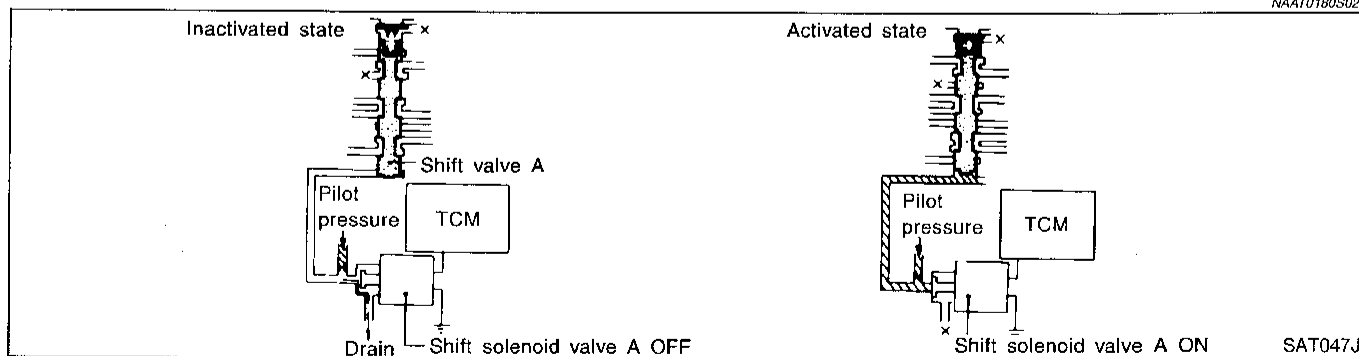

Pilot pressure generated by the operation of shift solenoid valves A and B is applied to the end face of shift valves A and B. The drawing above shows the operation of shift valve B. When the shift solenoid valve is "ON", pilot pressure applied to the end face of the shift valve overcomes spring force, moving the valve upward.

LOCK-UP CONTROL

The torque converter clutch piston in the torque converter is locked to eliminate torque converter slip to increase power transmission efficiency. The solenoid valve is controlled by an ON-OFF duty signal sent from the TCM. The signal is converted to oil pressure signal which controls the torque converter clutch piston.

Conditions for Lock-up Operation

When vehicle is driven in 4th gear position, vehicle speed and throttle opening are detected. If the detected values fall within the lock-up zone memorized in the TCM, lock-up is performed.

Overdrive control switch	ON	OFF
Selector lever	"D" position	
Gear position	D ₄	D ₃
Vehicle speed sensor	More than set value	
Throttle position sensor	Less than set opening	
Closed throttle position switch	OFF	
A/T fluid temperature sensor	More than 40°C (104°F)	

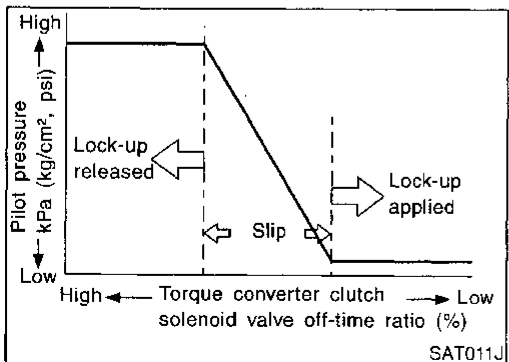
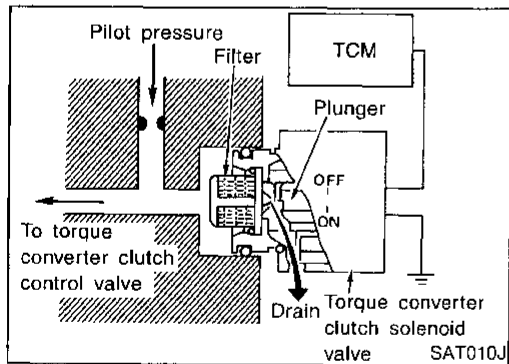

Torque Converter Clutch Solenoid Valve Control

The torque converter clutch solenoid valve is controlled by the TCM. The plunger closes the drain circuit during the "OFF" period, and opens the circuit during the "ON" period. If the percentage of OFF-time increases in one cycle, the pilot pressure drain time is reduced and pilot pressure remains high.

The torque converter clutch piston is designed to slip to adjust the ratio of ON-OFF, thereby reducing lock-up shock.

OFF-time INCREASING
 ↓
 Amount of drain DECREASING
 ↓
 Pilot pressure HIGH
 ↓
 Lock-up RELEASING

OVERALL SYSTEM

Control Mechanism (Cont'd)

Torque Converter Clutch Control Valve Operation

NAAT0180S0303

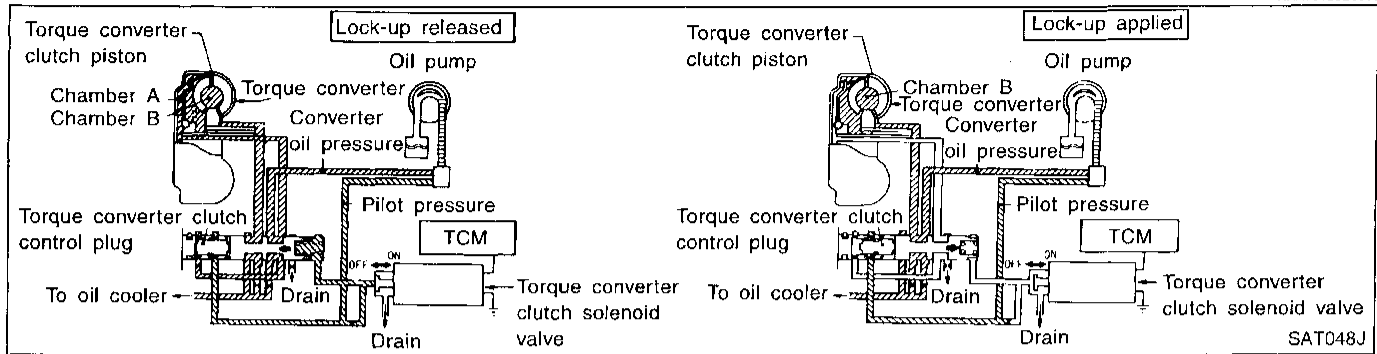

Lock-up Released

The OFF-duration of the torque converter clutch solenoid valve is long, and pilot pressure is high. The pilot pressure pushes the end face of the torque converter clutch control valve in combination with spring force to move the valve to the left. As a result, converter pressure is applied to chamber A (torque converter clutch piston release side). Accordingly, the torque converter clutch piston remains unlocked.

Lock-up Applied

When the OFF-duration of the torque converter clutch solenoid valve is short, pilot pressure drains and becomes low. Accordingly, the control valve moves to the right by the pilot pressure of the other circuit and converter pressure. As a result, converter pressure is applied to chamber B, keeping the torque converter clutch piston applied.

Also smooth lock-up is provided by transient application and release of the lock-up.

OVERRUN CLUTCH CONTROL (ENGINE BRAKE CONTROL)

NAAT0180S04

Forward one-way clutch is used to reduce shifting shocks in downshifting operations. This clutch transmits engine torque to the wheels. However, drive force from the wheels is not transmitted to the engine because the one-way clutch rotates idle. This means the engine brake is not effective.

The overrun clutch operates when the engine brake is needed.

Overrun Clutch Operating Conditions

NAAT0180S0401

	Gear position	Throttle opening
"D" position	D ₁ , D ₂ , D ₃ gear position	Less than 3/16
"2" position	2 ₁ , 2 ₂ gear position	
"1" position	1 ₁ , 1 ₂ gear position	At any position

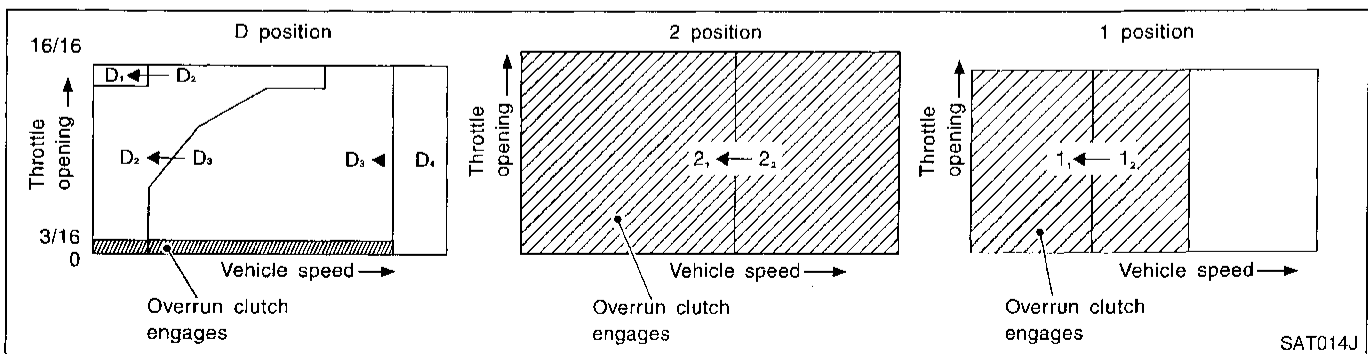

SAT014J

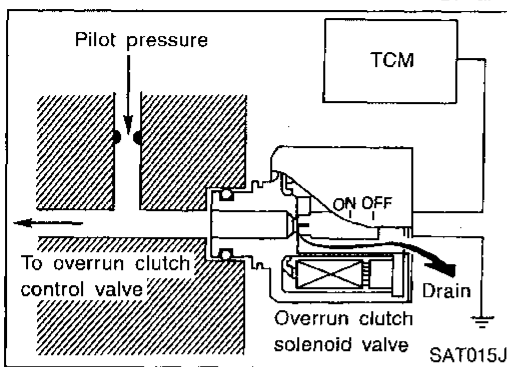

Overrun Clutch Solenoid Valve Control

NAAT0180S0402

The overrun clutch solenoid valve is operated by an ON-OFF signal transmitted by the TCM to provide overrun clutch control (engine brake control).

When this solenoid valve is "ON", the pilot pressure drain port closes. When it is "OFF", the drain port opens.

During the solenoid valve "ON" pilot pressure is applied to the end face of the overrun clutch control valve.

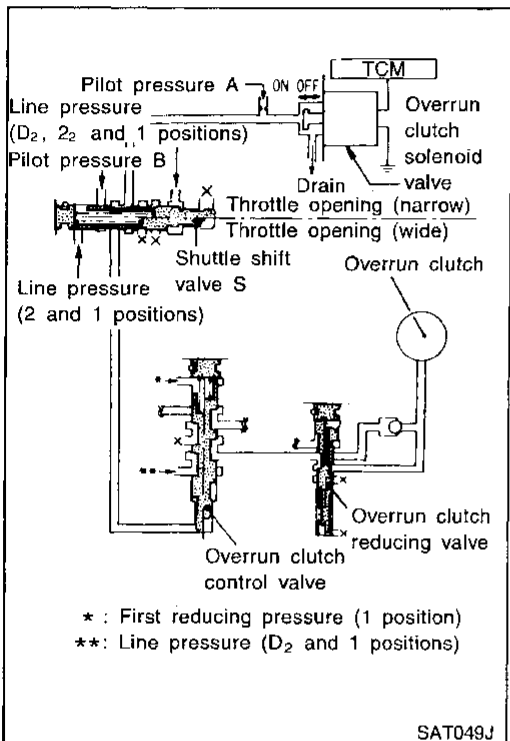

Overrun Clutch Control Valve Operation

NAAT0180S0403

When the solenoid valve is "ON", pilot pressure A is applied to the overrun clutch control valve. This pushes up the overrun clutch control valve. The line pressure is then shut off so that the clutch does not engage.

When the solenoid valve is "OFF", pilot pressure A is not generated. At this point, the overrun clutch control valve moves downward by spring force. As a result, overrun clutch operation pressure is provided by the overrun clutch reducing valve. This causes the overrun clutch to engage.

In the "1" position, the overrun clutch control valve remains pushed down so that the overrun clutch is engaged at all times.

- * : First reducing pressure (1 position)
- ** : Line pressure (D₂ and 1 positions)

Control Valve

NAAT0161

NAAT0181S01

FUNCTION OF CONTROL VALVE

Valve name	Function
<ul style="list-style-type: none"> ● Pressure regulator valve ● Pressure regulator plug ● Pressure regulator sleeve plug 	Regulate oil discharged from the oil pump to provide optimum line pressure for all driving conditions.
Pressure modifier valve	Used as a signal supplementary valve to the pressure regulator valve. Regulates pressure-modifier pressure (signal pressure) which controls optimum line pressure for all driving conditions.
Modifier accumulator piston	Smooths hydraulic pressure regulated by the pressure modifier valve to prevent pulsations.
Pilot valve	Regulates line pressure to maintain a constant pilot pressure level which controls lock-up mechanism, overrun clutch, 3-2 timing required for shifting.
Accumulator control valve Accumulator control sleeve	Regulate accumulator backpressure to pressure suited to driving conditions.
Manual valve	Directs line pressure to oil circuits corresponding to select positions. Hydraulic pressure drains when the shift lever is in Neutral.

OVERALL SYSTEM

Control Valve (Cont'd)

Valve name	Function
Shift valve A	Simultaneously switches three oil circuits using output pressure of shift solenoid valve A to meet driving conditions (vehicle speed, throttle opening, etc.). Provides automatic downshifting and up-shifting (1st → 2nd → 3rd → 4th gears/4th → 3rd → 2nd → 1st gears) in combination with shift valve B.
Shift valve B	Simultaneously switches three oil circuits using output pressure of shift solenoid valve B in relation to driving conditions (vehicle speed, throttle opening, etc.). Provides automatic downshifting and up-shifting (1st → 2nd → 3rd → 4th gears/4th → 3rd → 2nd → 1st gears) in combination with shift valve A.
Shuttle shift valve S	Switches hydraulic circuits to provide 3-2 timing control and overrun clutch control in relation to the throttle opening. Inactivates the overrun clutch to prevent interlocking in 4th gear when the throttle is wide open.
Overrun clutch control valve	Switches hydraulic circuits to prevent engagement of the overrun clutch simultaneously with application of the brake band in 4th gear. (Interlocking occurs if the overrun clutch engages during D ₄ gear operation.)
4-2 relay valve	Memorizes that the transmission is in 4th gear. Prevents the transmission from downshifting from 4th gear to 3rd and then to 2nd in combination with 4-2 sequence valve and shift valves A and B when downshifting from 4th to 2nd gear.
4-2 sequence valve	Prevents band servo pressure from draining before high clutch operating pressure and band servo releasing pressure drain (from the same circuit) during downshifting from 4th to 2nd gear.
Servo charger valve	An accumulator and a one-way orifice are used in the 2nd gear band servo oil circuit to dampen shifting shock when shifting from 1st to 2nd gear. To maintain adequate flowrate when downshifting from 4th or 3rd gear to 2nd gear, the servo charger valve directs 2nd gear band servo hydraulic pressure to the circuit without going through the one-way orifice when downshifting from 3rd or a higher gear.
3-2 timing valve	Prevents a late operation of the brake band when shifting selector lever from "D" to "1" or "2" position while driving in D ₃ .
"1" reducing valve	Reduces low & reverse brake pressure to dampen engine-brake shock when downshifting from the "1" position 2nd gear to 1st gear.
Overrun clutch reducing valve	Reduces oil pressure directed to the overrun clutch and prevents engine-brake shock. In "1" and "2" positions, line pressure acts on the overrun clutch reducing valve to increase the pressure-regulating point, with resultant engine brake capability.
Torque converter relief valve	Prevents an excessive rise in torque converter pressure.
Torque converter clutch control valve, torque converter clutch control plug and torque converter clutch control sleeve	Activate or inactivate the lock-up function. Also provide smooth lock-up through transient application and release of the lock-up system.
Shuttle shift valve D	Switches hydraulic circuits so that output pressure of the torque converter clutch solenoid valve acts on the lock-up valve in the "D" position of 2nd, 3rd and 4th gears. (In the "D" position 1st gear, lock-up is inhibited.) <ul style="list-style-type: none"> ● Lock-up control is not affected in "D" position 2nd, 3rd or 4th gears, unless output pressure of the torque converter clutch solenoid valve is generated by a signal from the control unit.

Introduction

The A/T system has two self-diagnostic systems.

The first is the emission-related on board diagnostic system (OBD-II) performed by the TCM in combination with the ECM (ECCS control module). The malfunction is indicated by the MIL (malfunction indicator lamp) and is stored as a DTC in the ECM memory but not the TCM memory.

The second is the TCM original self-diagnosis indicated by the O/D OFF indicator lamp. The malfunction is stored in the TCM memory. The detected items are overlapped with OBD-II self-diagnostic items. For detail, refer to AT-45.

OBD-II Function for A/T System

The ECM (ECCS control module) provides emission-related on board diagnostic (OBD-II) functions for the A/T system. One function is to receive a signal from the TCM used with OBD-related parts of the A/T system. The signal is sent to the ECM when a malfunction occurs in the corresponding OBD-related part. The other function is to indicate a diagnostic result by means of the MIL (malfunction indicator lamp) on the instrument panel. Sensors, switches and solenoid valves are used as sensing elements.

The MIL automatically illuminates in One or Two Trip Detection Logic when a malfunction is sensed in relation to A/T system parts.

One or Two Trip Detection Logic of OBD-II

ONE TRIP DETECTION LOGIC

If a malfunction is sensed during the first test drive, the MIL will illuminate and the malfunction will be stored in the ECM memory as a DTC. The TCM is not provided with such a memory function.

TWO TRIP DETECTION LOGIC

When a malfunction is sensed during the first test drive, it is stored in the ECM memory as a 1st trip DTC (diagnostic trouble code) or 1st trip freeze frame data. At this point, the MIL will not illuminate. — First Trip
If the same malfunction as that experienced during the first test drive is sensed during the second test drive, the MIL will illuminate. — Second Trip

A/T-related parts for which the MIL illuminates during the first or second test drive are listed below.



Items	MIL	
	One trip detection	Two trip detection
Shift solenoid valve A — DTC: P0750 (1108)	X	
Shift solenoid valve B — DTC: P0755 (1201)	X	
Throttle position sensor or switch — DTC: P1705 (1206)	X	
Except above		X

The “trip” in the “One or Two Trip Detection Logic” means a driving mode in which self-diagnosis is performed during vehicle operation.

OBD-II Diagnostic Trouble Code (DTC)

HOW TO READ DTC AND 1ST TRIP DTC

DTC and 1st trip DTC can be read by the following methods.

1. **( No Tools)** The number of blinks of the malfunction indicator lamp in the Diagnostic Test Mode II (Self-Diagnostic Results) Examples: 1101, 1102, 1103, 1104, etc. For details, refer to EC section [“Malfunction Indicator Lamp (MIL)”, “ON BOARD DIAGNOSTIC SYSTEM DESCRIPTION”].
These DTCs are controlled by NISSAN.
2. **( with CONSULT or  GST)** CONSULT or GST (Generic Scan Tool) Examples: P0705, P0710, P0720, P0725, etc.
These DTCs are prescribed by SAE J2012.
(CONSULT also displays the malfunctioning component or system.)
 - **1st trip DTC No. is the same as DTC No.**
 - **Output of the diagnostic trouble code indicates that the indicated circuit has a malfunction. However, in case of the Mode II and GST they do not indicate whether the malfunction is still occurring or occurred in the past and returned to normal. CONSULT can identify them as shown below. Therefore, using CONSULT (if available) is recommended.**

ON BOARD DIAGNOSTIC SYSTEM DESCRIPTION

OBD-II Diagnostic Trouble Code (DTC) (Cont'd)

A sample of CONSULT display for DTC is shown at left. DTC or 1st trip DTC of a malfunction is displayed in SELF-DIAGNOSTIC RESULTS mode for "ENGINE" with CONSULT. Time data indicates how many times the vehicle was driven after the last detection of a DTC.

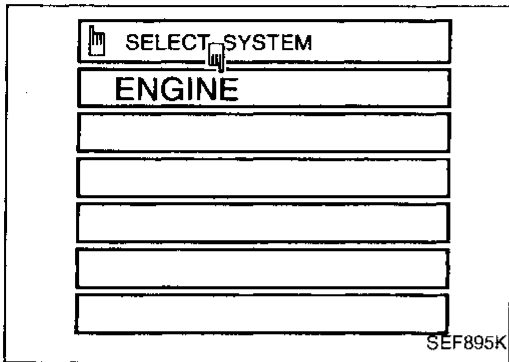

If the DTC is being detected currently, the time data will be "0".

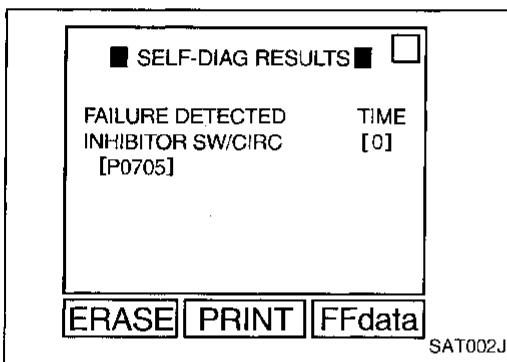

If a 1st trip DTC is stored in the ECM, the time data will be "[1t]".

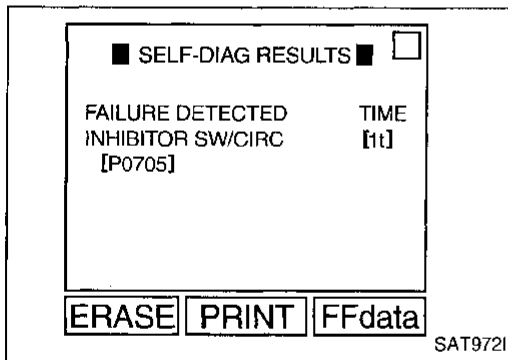

Freeze Frame Data and 1st Trip Freeze Frame Data

NAAT0016S0101

The ECM has a memory function, which stores the driving condition such as fuel system status, calculated load value, engine coolant temperature, short term fuel trim, long term fuel trim, engine speed and vehicle speed at the moment the ECM detects a malfunction.

Data which are stored in the ECM memory, along with the 1st trip DTC, are called 1st trip freeze frame data, and the data, stored together with the DTC data, are called freeze frame data and displayed on CONSULT or GST. The 1st trip freeze frame data can only be displayed on the CONSULT screen, not on the GST. For detail, refer to EC section ("CONSULT", "ON BOARD DIAGNOSTIC SYSTEM DESCRIPTION").

Only one set of freeze frame data (either 1st trip freeze frame data or freeze frame data) can be stored in the ECM. 1st trip freeze frame data is stored in the ECM memory along with the 1st trip DTC. There is no priority for 1st trip freeze frame data and it is updated each time a different 1st trip DTC is detected. However, once freeze frame data (2nd trip detection/MIL on) is stored in the ECM memory, 1st trip freeze frame data is no longer stored. Remember, only one set of freeze frame data can be stored in the ECM. The ECM has the following priorities to update the data.

ON BOARD DIAGNOSTIC SYSTEM DESCRIPTION

OBD-II Diagnostic Trouble Code (DTC) (Cont'd)

Priority	Items	
1	Freeze frame data	Misfire — DTC: P0300 - P0306 (0701, 0603 - 0608) Fuel Injection System Function — DTC: P0171 (0115), P0172 (0114), P0174 (0209), P0175 (0210)
2		Except the above items (Includes A/T related items)
3	1st trip freeze frame data	

Both 1st trip freeze frame data and freeze frame data (along with the DTCs) are cleared when the ECM memory is erased.

HOW TO ERASE DTC

The diagnostic trouble code can be erased by CONSULT, GST or ECM DIAGNOSTIC TEST MODE as described following.

- If the battery terminal is disconnected, the diagnostic trouble code will be lost within 24 hours.
- When you erase the DTC, using CONSULT or GST is easier and quicker than switching the mode selector on the ECM.

The following emission-related diagnostic information is cleared from the ECM memory when erasing DTC related to OBD-II. For details, refer to EC section ("Emission-related Diagnostic Information", "ON BOARD DIAGNOSTIC SYSTEM DESCRIPTION").

- Diagnostic trouble codes (DTC)
- 1st trip diagnostic trouble codes (1st trip DTC)
- Freeze frame data
- 1st trip freeze frame data
- System readiness test (SRT) codes
- Test values

Ⓜ HOW TO ERASE DTC (WITH CONSULT)

- If a DTC is displayed for both ECM and TCM, it needs to be erased for both ECM and TCM.
1. If the ignition switch stays "ON" after repair work, be sure to turn ignition switch "OFF" once. Wait at least 5 seconds and then turn it "ON" (engine stopped) again.
 2. Turn CONSULT "ON" and touch "A/T".
 3. Touch "SELF-DIAG RESULTS".
 4. Touch "ERASE". (The DTC in the TCM will be erased.) Then touch "BACK" twice.
 5. Touch "ENGINE".
 6. Touch "SELF-DIAG RESULTS".
 7. Touch "ERASE". (The DTC in the ECM will be erased.)

ON BOARD DIAGNOSTIC SYSTEM DESCRIPTION

OBD-II Diagnostic Trouble Code (DTC) (Cont'd)

How to erase DTC (With CONSULT)

1. If the ignition switch stays "ON" after repair work, be sure to turn ignition switch "OFF" once. Wait at least 5 seconds and then turn it "ON" (engine stopped) again.

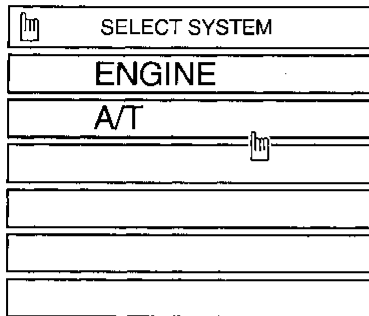

2. Turn CONSULT "ON", and touch "A/T".

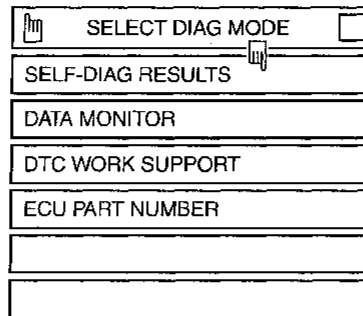

3. Touch "SELF-DIAG RESULTS".

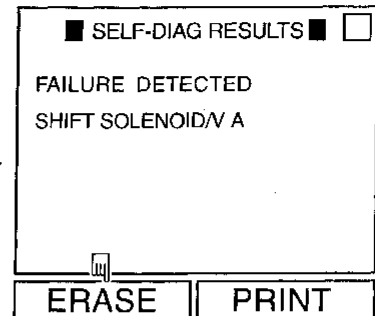

4. Touch "ERASE". (The DTC in the TCM will be erased.)

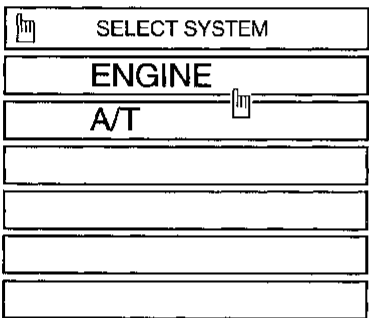
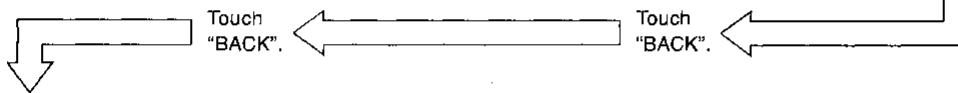

5. Touch "ENGINE".

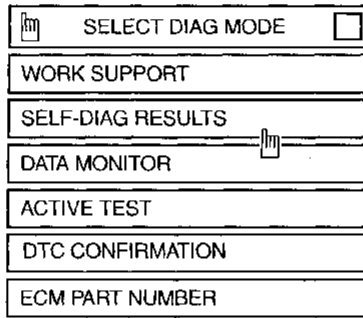

6. Touch "SELF-DIAG RESULTS".

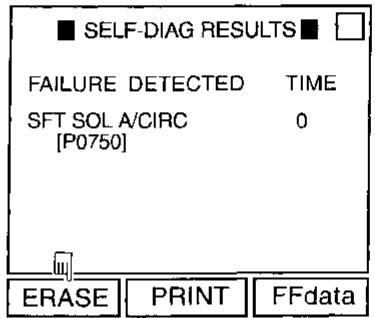

7. Touch "ERASE". (The DTC in the ECM will be erased.)

SAT9041

HOW TO ERASE DTC (WITH GST)

NAA70016S04

1. If the ignition switch stays "ON" after repair work, be sure to turn ignition switch "OFF" once. Wait at least 5 seconds and then turn it "ON" (engine stopped) again.
2. Perform "OBD-II SELF-DIAGNOSTIC PROCEDURE (No Tools)". Refer to AT-44. (The engine warm-up step can be skipped when performing the diagnosis only to erase the DTC.)
3. Select Mode 4 with Generic Scan Tool (GST). For details, refer to EC section ["Generic Scan Tool (GST)", "ON BOARD DIAGNOSTIC SYSTEM DESCRIPTION"].

HOW TO ERASE DTC (NO TOOLS)

NAA70016S05

1. If the ignition switch stays "ON" after repair work, be sure to turn ignition switch "OFF" once. Wait at least 5 seconds and then turn it "ON" (engine stopped) again.
2. Perform "TCM SELF-DIAGNOSTIC PROCEDURE (No Tools)". Refer to AT-44. (The engine warm-up step can be skipped when performing the diagnosis only to erase the DTC.)
3. Change the diagnostic test mode from Mode II to Mode I by turning the mode selector on the ECM. Refer to EC section ["HOW TO SWITCH DIAGNOSTIC TEST MODES", "Malfunction Indicator Lamp (MIL)", "ON BOARD DIAGNOSTIC SYSTEM DESCRIPTION"].

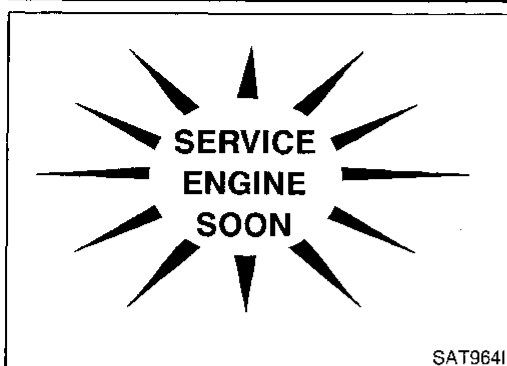

Malfunction Indicator Lamp (MIL)

1. The malfunction indicator lamp will light up when the ignition switch is turned ON without the engine running. This is for checking the blown lamp.
 - If the malfunction indicator lamp does not light up, refer to EL section ("Warning Lamps/System Description", "WARNING LAMPS AND CHIME"). (Or see MIL & Data Link Connectors in EC section.)
2. When the engine is started, the malfunction indicator lamp should go off. If the lamp remains on, the on board diagnostic system has detected an emission-related (OBD-II) malfunction. For detail, refer to EC section ("ON BOARD DIAGNOSTIC SYSTEM DESCRIPTION").

GI
MA
EM
LC
EC
FE
CL
MT
AT

CONSULT

After performing "SELF-DIAGNOSTIC PROCEDURE (WITH CONSULT)" (AT-36), place check marks for results on the "DIAGNOSTIC WORKSHEET", AT-50. Reference pages are provided following the items.

NOTICE:

- 1) The CONSULT electrically displays shift timing and lock-up timing (that is, operation timing of each solenoid). Check for time difference between actual shift timing and the CONSULT display. If the difference is noticeable, mechanical parts (except solenoids, sensors, etc.) may be malfunctioning. Check mechanical parts using applicable diagnostic procedures.
- 2) Shift schedule (which implies gear position) displayed on CONSULT and that indicated in Service Manual may differ slightly. This occurs because of the following reasons:
 - Actual shift schedule has more or less tolerance or allowance,
 - Shift schedule indicated in Service Manual refers to the point where shifts start, and
 - Gear position displayed on CONSULT indicates the point where shifts are completed.
- 3) Shift solenoid valve "A" or "B" is displayed on CONSULT at the start of shifting. Gear position is displayed upon completion of shifting (which is computed by TCM).
- 4) Additional CONSULT information can be found in the Operation Manual supplied with the CONSULT unit.

TF
PD
AX
SU
BR
ST
RS
BT
HA
SC
EL
IDX

ON BOARD DIAGNOSTIC SYSTEM DESCRIPTION

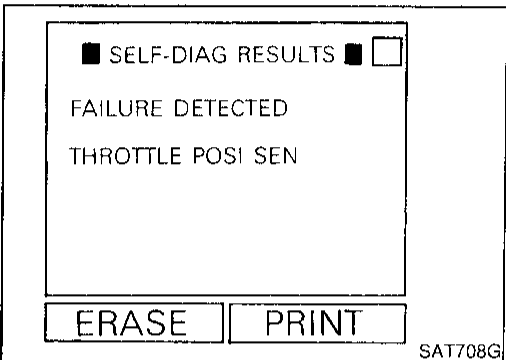
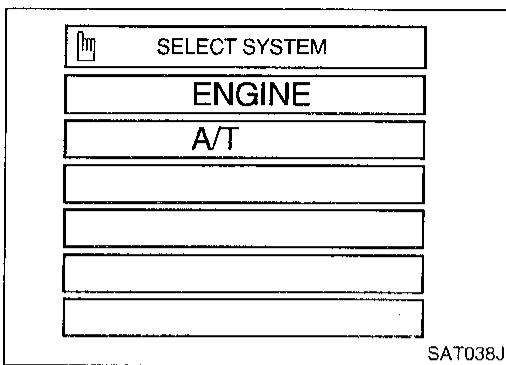

CONSULT (Cont'd)



Ⓜ SELF-DIAGNOSTIC PROCEDURE (WITH CONSULT) NAAT0184901



1. Turn on CONSULT and touch "ENGINE" for OBD-II detected items or touch "A/T" for TCM self-diagnosis.
If A/T is not displayed, check TCM power supply and ground circuit. Refer to AT-80. If result is NG, refer to EL section ("POWER SUPPLY ROUTING").
2. Touch "SELF-DIAG RESULTS".
Display shows malfunction experienced since the last erasing operation.
CONSULT performs REAL-TIME SELF-DIAGNOSIS.
Also, any malfunction detected while in this mode will be displayed at real time.

SELF-DIAGNOSTIC RESULT TEST MODE NAAT0184S02

Detected items (Screen terms for CONSULT, "SELF-DIAG RESULTS" test mode)		Malfunction is detected when ...	TCM self-diagnosis	OBD-II (DTC)	
"A/T"	"ENGINE"		 Available by O/D OFF indicator lamp or "A/T" on CONSULT	 Available by malfunction indicator lamp*2, "ENGINE" on CON- SULT or GST	
Inhibitor switch circuit	—	INHIBITOR SW/CIRC	• TCM does not receive the correct voltage signal (based on the gear position) from the switch.	—	P0705
Revolution sensor	VHCL SPEED SEN-A/T	VEH SPD SEN/CIR AT	• TCM does not receive the proper voltage signal from the sensor.	X	P0720
Vehicle speed sensor (Meter)	VHCL SPEED SEN-MTR	—	• TCM does not receive the proper voltage signal from the sensor.	X	—
A/T 1st gear function	—	A/T 1ST GR FNCTN	• A/T cannot be shifted to the 1st gear position even if electrical circuit is good.	—	P0731*1
A/T 2nd gear function	—	A/T 2ND GR FNCTN	• A/T cannot be shifted to the 2nd gear position even if electrical circuit is good.	—	P0732*1
A/T 3rd gear function	—	A/T 3RD GR FNCTN	• A/T cannot be shifted to the 3rd gear position even if electrical circuit is good.	—	P0733*1
A/T 4th gear function	—	A/T 4TH GR FNCTN	• A/T cannot be shifted to the 4th gear position even if electrical circuit is good.	—	P0734*1

ON BOARD DIAGNOSTIC SYSTEM DESCRIPTION

CONSULT (Cont'd)

Detected items (Screen terms for CONSULT, "SELF-DIAG RESULTS" test mode)		Malfunction is detected when ...	TCM self-diagnosis	OBD-II (DTC)
"A/T"	"ENGINE"		 Available by O/D OFF indicator lamp or "A/T" on CONSULT	 Available by malfunction indicator lamp*2, "ENGINE" on CON- SULT or GST
—	A/T TCC S/V FNCTN	<ul style="list-style-type: none"> A/T cannot perform lock-up even if electrical circuit is good. 	—	P0744*1
A/T TCC S/V function (lock-up)				
SHIFT SOLENOID/ A	SFT SOL A/CIRC	<ul style="list-style-type: none"> TCM detects an improper voltage drop when it tries to operate the solenoid valve. 	X	P0750
Shift solenoid valve A				
SHIFT SOLENOID/ B	SFT SOL B/CIRC	<ul style="list-style-type: none"> TCM detects an improper voltage drop when it tries to operate the solenoid valve. 	X	P0755
Shift solenoid valve B				
OVERRUN CLUTCH S/V	O/R CLUCH SOL/ CIRC	<ul style="list-style-type: none"> TCM detects an improper voltage drop when it tries to operate the solenoid valve. 	X	P1760
Overrun clutch solenoid valve				
T/C CLUTCH SOL/V	TCC SOLENOID/ CIRC	<ul style="list-style-type: none"> TCM detects an improper voltage drop when it tries to operate the solenoid valve. 	X	P0740
T/C clutch solenoid valve				
LINE PRESSURE S/V	L/PRESS SOL/CIRC	<ul style="list-style-type: none"> TCM detects an improper voltage drop when it tries to operate the solenoid valve. 	X	P0745
Line pressure solenoid valve				
THROTTLE POSI SEN	TP SEN/CIRC A/T	<ul style="list-style-type: none"> TCM receives an excessively low or high voltage from the sensor. 	X	P1705
Throttle position sensor Throttle position switch				
ENGINE SPEED SIG		<ul style="list-style-type: none"> TCM does not receive the proper voltage signal from the ECM. 	X	P0725
Engine speed signal				
BATT/FLUID TEMP SEN	ATF TEMP SEN/ CIRC	<ul style="list-style-type: none"> TCM receives an excessively low or high voltage from the sensor. 	X	P0710
A/T fluid temperature sensor				
INITIAL START	—	<ul style="list-style-type: none"> This is not a malfunction message (Whenever shutting off a power supply to the control unit, this message appears on the screen.) 	X	—
Initial start				
(NO SELF DIAGNOSTIC FAILURE INDICATED FURTHER TESTING MAY BE REQUIRED**)		<ul style="list-style-type: none"> No failure has been detected. 	X	X

X: Applicable

—: Not applicable

*1: These malfunctions cannot be displayed by MIL  if another malfunction is assigned to MIL.

*2: Refer to EC section ["Malfunction Indicator Lamp (MIL)", "ON BOARD DIAGNOSTIC SYSTEM DESCRIPTION"].

ON BOARD DIAGNOSTIC SYSTEM DESCRIPTION

CONSULT (Cont'd)

DATA MONITOR MODE (A/T)

NAAT0184S03

Item	Display	Monitor item		Description	Remarks
		ECU input signals	Main signals		
Vehicle speed sensor 1 (A/T) (Revolution sensor)	VHCL/S SE-A/T [km/h] or [mph]	X	—	<ul style="list-style-type: none"> Vehicle speed computed from signal of revolution sensor is displayed. 	When racing engine in "N" or "P" position with vehicle stationary, CONSULT data may not indicate 0 km/h (0 mph).
Vehicle speed sensor 2 (Meter)	VHCL/S SE-MTR [km/h] or [mph]	X	—	<ul style="list-style-type: none"> Vehicle speed computed from signal of vehicle speed sensor is displayed. 	Vehicle speed display may not be accurate under approx. 10 km/h (6 mph). It may not indicate 0 km/h (0 mph) when vehicle is stationary.
Throttle position sensor	THRTL POS SEN [V]	X	—	<ul style="list-style-type: none"> Throttle position sensor signal voltage is displayed. 	
A/T fluid temperature sensor	FLUID TEMP SE [V]	X	—	<ul style="list-style-type: none"> A/T fluid temperature sensor signal voltage is displayed. Signal voltage lowers as fluid temperature rises. 	
Battery voltage	BATTERY VOLT [V]	X	—	<ul style="list-style-type: none"> Source voltage of TCM is displayed. 	
Engine speed	ENGINE SPEED [rpm]	X	X	<ul style="list-style-type: none"> Engine speed, computed from engine speed signal, is displayed. 	Engine speed display may not be accurate under approx. 800 rpm. It may not indicate 0 rpm even when engine is not running.
Overdrive control switch	OVERDRIVE SW [ON/OFF]	X	—	<ul style="list-style-type: none"> ON/OFF state computed from signal of overdrive control SW is displayed. 	
P/N position switch	P/N POSI SW [ON/OFF]	X	—	<ul style="list-style-type: none"> ON/OFF state computed from signal of P/N position SW is displayed. 	
R position switch	R POSITION SW [ON/OFF]	X	—	<ul style="list-style-type: none"> ON/OFF state computed from signal of R position SW is displayed. 	
D position switch	D POSITION SW [ON/OFF]	X	—	<ul style="list-style-type: none"> ON/OFF state computed from signal of D position SW is displayed. 	
2 position switch	2 POSITION SW [ON/OFF]	X	—	<ul style="list-style-type: none"> ON/OFF status, computed from signal of 2 position SW, is displayed. 	
1 position switch	1 POSITION SW [ON/OFF]	X	—	<ul style="list-style-type: none"> ON/OFF status, computed from signal of 1 position SW, is displayed. 	

ON BOARD DIAGNOSTIC SYSTEM DESCRIPTION

CONSULT (Cont'd)

Item	Display	Monitor item		Description	Remarks
		ECU input signals	Main signals		
ASCD cruise signal	ASCD-CRUISE [ON/OFF]	X	—	<ul style="list-style-type: none"> Status of ASCD cruise signal is displayed. ON ... Cruising state OFF ... Normal running state 	<ul style="list-style-type: none"> This is displayed even when no ASCD is mounted.
ASCD OD cut signal	ASCD OD CUT [ON/OFF]	X	—	<ul style="list-style-type: none"> Status of ASCD OD release signal is displayed. ON ... OD released OFF ... OD not released 	<ul style="list-style-type: none"> This is displayed even when no ASCD is mounted.
Kickdown switch	KICKDOWN SW [ON/OFF]	X	—	<ul style="list-style-type: none"> ON/OFF status, computed from signal of kickdown SW, is displayed. 	<ul style="list-style-type: none"> This is displayed even when no kickdown switch is equipped.
Closed throttle position switch	CLOSED THL/SW [ON/OFF]	X	—	<ul style="list-style-type: none"> ON/OFF status, computed from signal of closed throttle position SW, is displayed. 	
Wide open throttle position switch	W/O THRL/P-SW [ON/OFF]	X	—	<ul style="list-style-type: none"> ON/OFF status, computed from signal of wide open throttle position SW, is displayed. 	
Gear position	GEAR	—	X	<ul style="list-style-type: none"> Gear position data used for computation by TCM, is displayed. 	
Selector lever position	SLCT LVR POSI	—	X	<ul style="list-style-type: none"> Selector lever position data, used for computation by TCM, is displayed. 	<ul style="list-style-type: none"> A specific value used for control is displayed if fail-safe is activated due to error.
Vehicle speed	VEHICLE SPEED [km/h] or [mph]	—	X	<ul style="list-style-type: none"> Vehicle speed data, used for computation by TCM, is displayed. 	
Throttle position	THROTTLE POSI [°]	—	X	<ul style="list-style-type: none"> Throttle position data, used for computation by TCM, is displayed. 	<ul style="list-style-type: none"> A specific value used for control is displayed if fail-safe is activated due to error.
Line pressure duty	LINE PRES DTY [%]	—	X	<ul style="list-style-type: none"> Control value of line pressure solenoid valve, computed by TCM from each input signal, is displayed. 	
Torque converter clutch solenoid valve duty	TCC S/V DUTY [%]	—	X	<ul style="list-style-type: none"> Control value of torque converter clutch solenoid valve, computed by TCM from each input signal, is displayed. 	

GI
 MA
 EM
 LC
 EC
 FE
 CL
 MT
 AT
 TF
 PD
 AX
 SU
 BR
 ST
 RS
 BT
 HA
 SC
 EL
 IDX

ON BOARD DIAGNOSTIC SYSTEM DESCRIPTION

CONSULT (Cont'd)

Item	Display	Monitor item		Description	Remarks
		ECU input signals	Main signals		
Shift solenoid valve A	SHIFT S/V A [ON/OFF]	—	X	<ul style="list-style-type: none"> Control value of shift solenoid valve A, computed by TCM from each input signal, is displayed. 	Control value of solenoid is displayed even if solenoid circuit is disconnected. The "OFF" signal is displayed if solenoid circuit is shorted.
Shift solenoid valve B	SHIFT S/V B [ON/OFF]	—	X	<ul style="list-style-type: none"> Control value of shift solenoid valve B, computed by TCM from each input signal, is displayed. 	
Overrun clutch solenoid valve	OVERRUN/C S/V [ON/OFF]	—	X	<ul style="list-style-type: none"> Control value of overrun clutch solenoid valve computed by TCM from each input signal is displayed. 	
Self-diagnosis display lamp (O/D OFF indicator lamp)	SELF-D DP LMP [ON/OFF]	—	X	<ul style="list-style-type: none"> Control status of O/D OFF indicator lamp is displayed. 	

X: Applicable

—: Not applicable

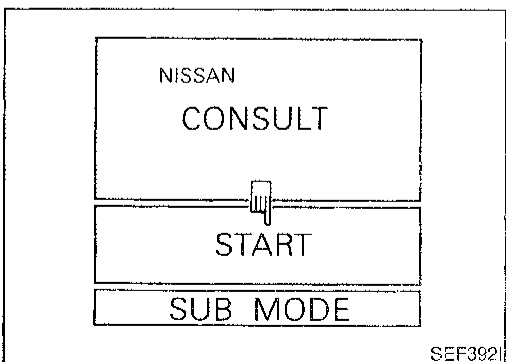
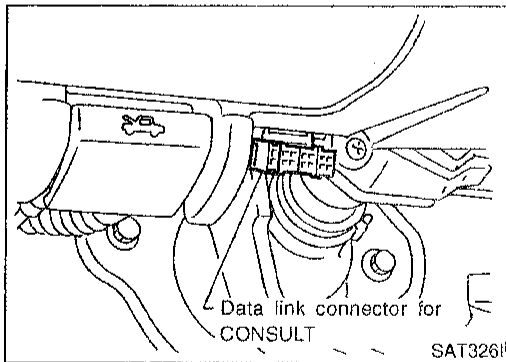

DTC WORK SUPPORT MODE WITH CONSULT CONSULT Setting Procedure

NAAT0184S04

NAAT0184S0401

1. Turn ignition switch "OFF".
2. Connect CONSULT to Data link connector for CONSULT. Data link connector for CONSULT is located in instrument lower panel on driver side.
3. Turn ignition switch "ON".
4. Touch "START".

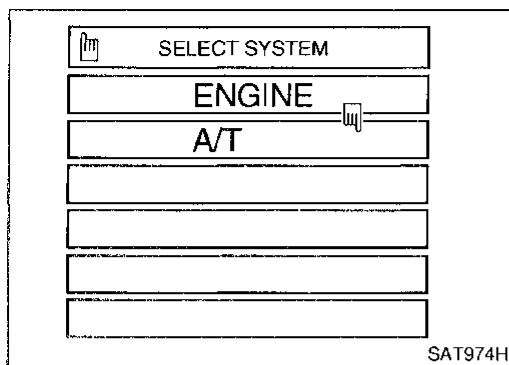

5. Touch "A/T".

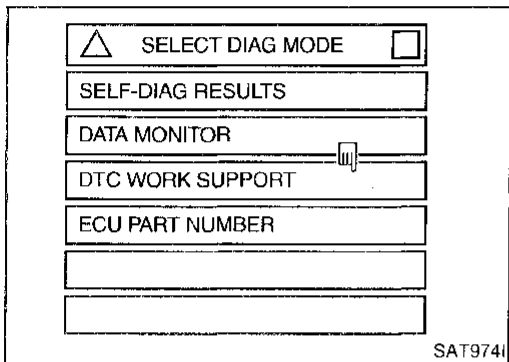

6. Touch "DTC WORK SUPPORT".

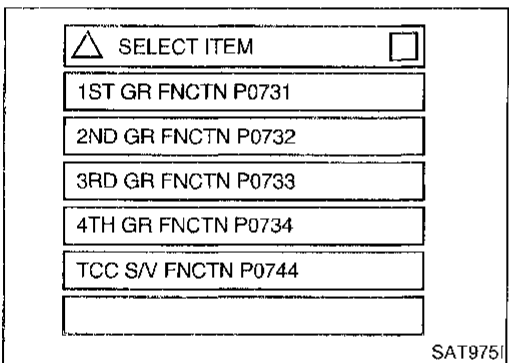

7. Touch select item menu (1ST, 2ND, etc.).

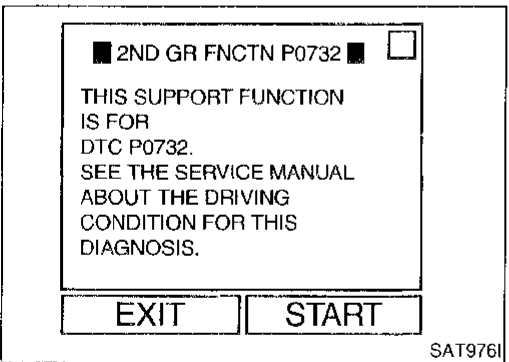

8. Touch "START".

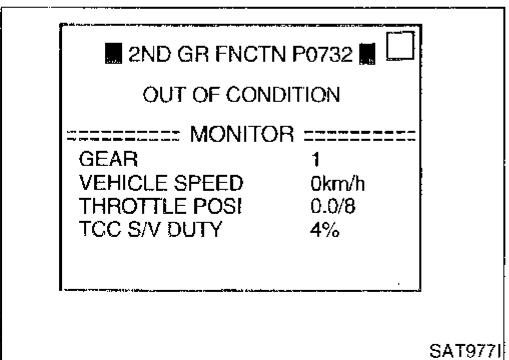

9. Perform driving test according to "DTC CONFIRMATION PROCEDURE" in "TROUBLE DIAGNOSIS FOR DTC".

GI
 MA
 EM
 LC
 EC
 FE
 CL
 MT
AT
 TF
 PD
 AX
 SU
 BR
 ST
 RS
 BT
 HA
 SC
 EL
 IDX

ON BOARD DIAGNOSTIC SYSTEM DESCRIPTION

CONSULT (Cont'd)

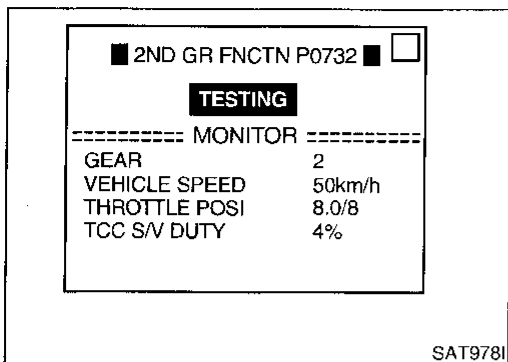

- When testing conditions are satisfied, CONSULT screen changes from "OUT OF CONDITION" to "TESTING".

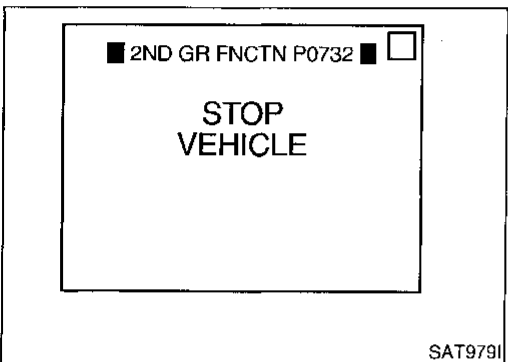

10. Stop vehicle. If "NG" appears on the screen, malfunction may exist. Go to "DIAGNOSTIC PROCEDURE".

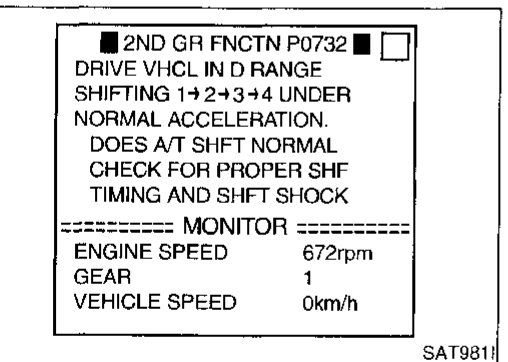
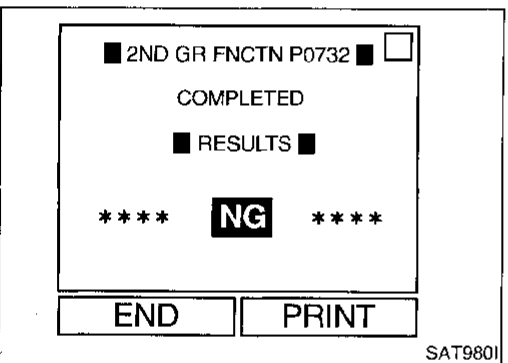

11. Perform test drive to check gear shift feeling in accordance with instructions displayed.

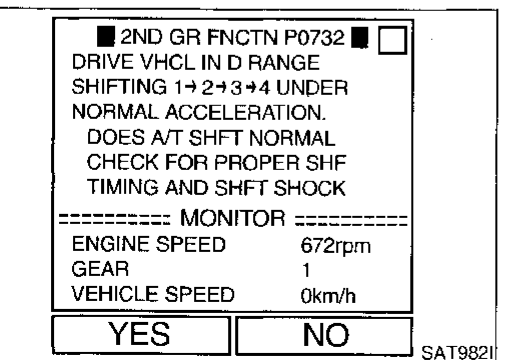

12. Touch "YES" or "NO".

ON BOARD DIAGNOSTIC SYSTEM DESCRIPTION

CONSULT (Cont'd)

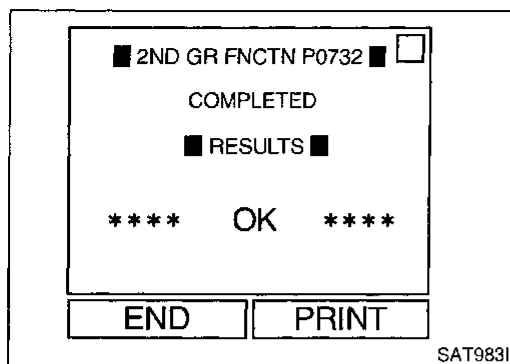

13. CONSULT procedure ended.
If "NG" appears on the screen, a malfunction may exist. Go to "DIAGNOSTIC PROCEDURE".

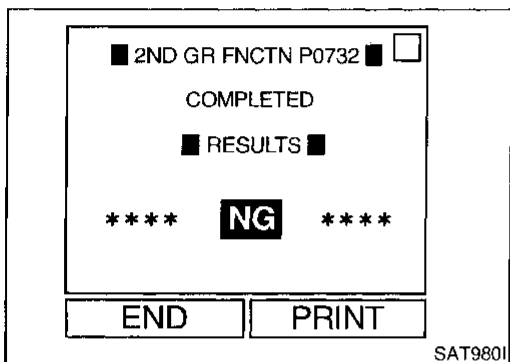

DTC WORK SUPPORT MODE

NAAT0184S05

DTC work support item	Description	Check item
1ST GR FNCTN P0731	<p>Following items for "A/T 1st gear function (P0731)" can be confirmed.</p> <ul style="list-style-type: none"> Self-diagnosis status (whether the diagnosis is being conducted or not) Self-diagnosis result (OK or NG) 	<ul style="list-style-type: none"> Shift solenoid valve A Shift solenoid valve B Each clutch Hydraulic control circuit
2ND GR FNCTN P0732	<p>Following items for "A/T 2nd gear function (P0732)" can be confirmed.</p> <ul style="list-style-type: none"> Self-diagnosis status (whether the diagnosis is being conducted or not) Self-diagnosis result (OK or NG) 	<ul style="list-style-type: none"> Shift solenoid valve B Each clutch Hydraulic control circuit
3RD GR FNCTN P0733	<p>Following items for "A/T 3rd gear function (P0733)" can be confirmed.</p> <ul style="list-style-type: none"> Self-diagnosis status (whether the diagnosis is being conducted or not) Self-diagnosis result (OK or NG) 	<ul style="list-style-type: none"> Shift solenoid valve A Each clutch Hydraulic control circuit
4TH GR FNCTN P0734	<p>Following items for "A/T 4th gear function (P0734)" can be confirmed.</p> <ul style="list-style-type: none"> Self-diagnosis status (whether the diagnosis is being conducted or not) Self-diagnosis result (OK or NG) 	<ul style="list-style-type: none"> Shift solenoid valve A Shift solenoid valve B Overrun clutch solenoid valve Line pressure solenoid valve Each clutch Hydraulic control circuit
TCC S/V FNCTN P0744	<p>Following items for "A/T TCC S/V function (lock-up)" can be confirmed.</p> <ul style="list-style-type: none"> Self-diagnosis status (whether the diagnosis is being conducted or not) Self-diagnosis result (OK or NG) 	<ul style="list-style-type: none"> Torque converter clutch solenoid valve Each clutch Hydraulic control circuit

DIAGNOSTIC PROCEDURE WITHOUT CONSULT

NAAT0184S06

OB2 Self-diagnostic Procedure (With GST)

Refer to EC section ["Generic Scan Tool (GST)", "ON BOARD DIAGNOSTIC SYSTEM DESCRIPTION"].

ON BOARD DIAGNOSTIC SYSTEM DESCRIPTION

CONSULT (Cont'd)

NO TOOLS OBD-II Self-diagnostic Procedure (No Tools)

Refer to EC section ["Malfunction Indicator Lamp (MIL)", "ON BOARD DIAGNOSTIC SYSTEM DESCRIPTION"].

NAAT0184S0602

NO TOOLS TCM Self-diagnostic Procedure (No Tools)

NAAT0184S0603

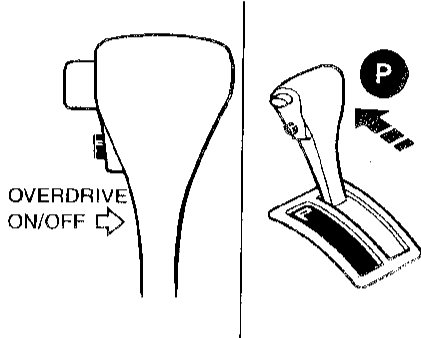
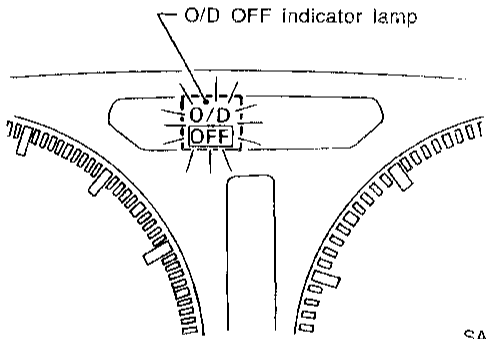
1	CHECK O/D OFF INDICATOR LAMP
<ol style="list-style-type: none"> Start engine and warm it up to normal engine operating temperature. Turn ignition switch to "OFF" position. Wait at least 5 seconds. Move selector lever to "P" position. 	
 <p style="text-align: right;">SAT967I</p>	
<ol style="list-style-type: none"> Turn ignition switch to "ON" position. (Do not start engine.) Does O/D OFF indicator lamp come on for about 2 seconds? 	
 <p style="text-align: right;">SAT325IA</p>	
Yes or No	
Yes	▶ GO TO 2.
No	▶ Go to "1. O/D OFF Indicator Lamp Does Not Come On", AT-185.

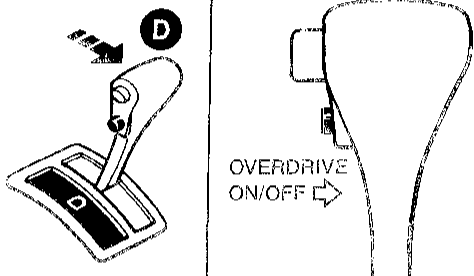
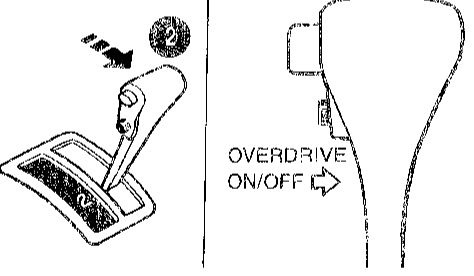
2	JUDGEMENT PROCEDURE STEP 1
<ol style="list-style-type: none"> Turn ignition switch to "OFF" position. Turn ignition switch to "ACC" position. Move selector lever to "D" position. Turn ignition switch to "ON" position. Do not start engine. Depress and hold overdrive control switch in "OFF" position until the next step is completed. Turn ignition switch to "OFF" position. 	
 <p style="text-align: right;">SAT968I</p>	
<ol style="list-style-type: none"> Turn ignition switch to "ON" position (Do not start engine.). <ul style="list-style-type: none"> Wait for more than 2 seconds after ignition switch "ON". Move selector lever to "2" position. Depress and hold overdrive control switch in "ON" position until the next step is completed. 	
 <p style="text-align: right;">SAT969I</p>	
▶ GO TO 3.	

3 JUDGEMENT PROCEDURE STEP 2

1. Move selector lever to "1" position.
2. Cycle overdrive control switch from "OFF" to "ON" position, depress and hold in the "OFF" position until the next step is completed.

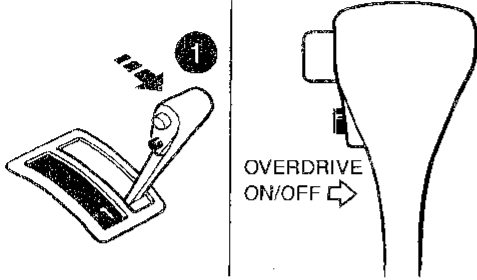

OVERDRIVE ON/OFF

3. Depress accelerator pedal fully and release it.

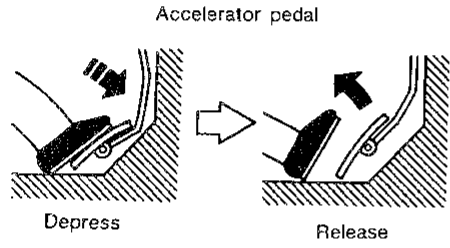

Accelerator pedal

Depress Release

SAT970I

SAT981F

▶ GO TO 4.

4 CHECK SELF-DIAGNOSIS CODE

Check O/D OFF indicator lamp.
Refer to JUDGEMENT OF SELF-DIAGNOSIS CODE, AT-45.

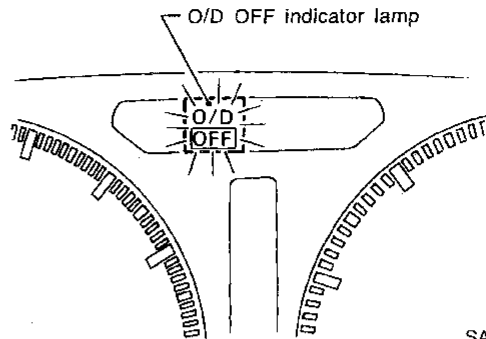

O/D OFF indicator lamp

SAT325IA

▶ DIAGNOSIS END

Judgement of Self-diagnosis Code

NAAT0184S0604

O/D OFF indicator lamp:

All judgement flickers are same.

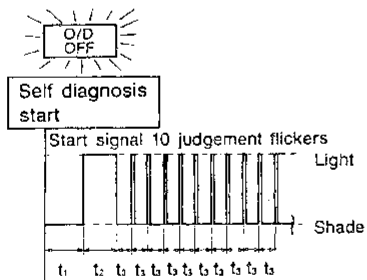

SAT436F

All circuits that can be confirmed by self-diagnosis are OK.

1st judgement flicker is longer than others.

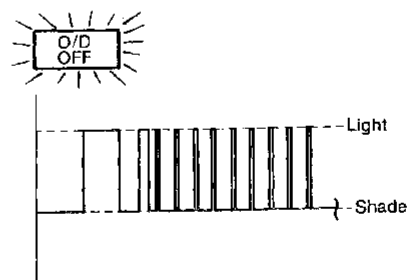

SAT437F

Revolution sensor circuit is short-circuited or disconnected.
⇒ Go to **VEHICLE SPEED SENSOR-A/T (REVOLUTION SENSOR) (DTC: 1102), AT-96.**

ON BOARD DIAGNOSTIC SYSTEM DESCRIPTION

CONSULT (Cont'd)

O/D OFF indicator lamp:

2nd judgement flicker is longer than others.

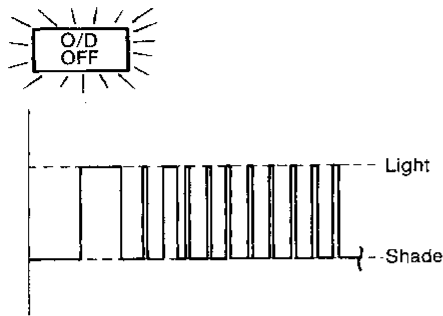

SAT439F

Vehicle speed sensor circuit is short-circuited or disconnected.
⇒ Go to **VEHICLE SPEED SENSOR-MTR, AT-178.**

3rd judgement flicker is longer than others.

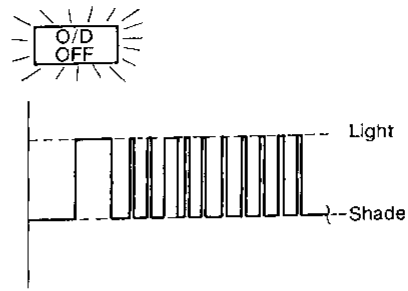

SAT441F

Throttle position sensor circuit is short-circuited or disconnected.
⇒ Go to **THROTTLE POSITION SENSOR (DTC: 1206), AT-161.**

4th judgement flicker is longer than others.

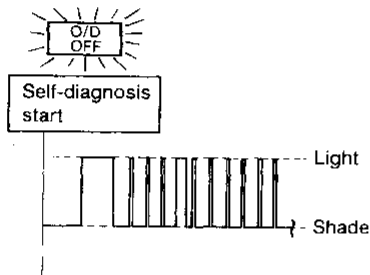

SAT443F

Shift solenoid valve A circuit is short-circuited or disconnected.
⇒ Go to **SHIFT SOLENOID VALVE A (DTC: 1108), AT-151.**

5th judgement flicker is longer than others.

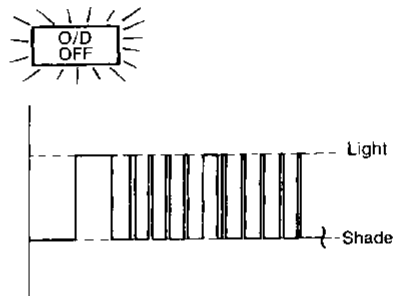

SAT445F

Shift solenoid valve B circuit is short-circuited or disconnected.
⇒ Go to **SHIFT SOLENOID VALVE B (DTC: 1201), AT-156.**

6th judgement flicker is longer than others.

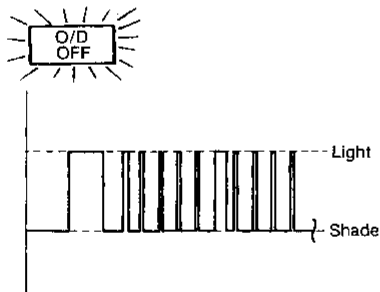

SAT447F

Overrun clutch solenoid valve circuit is short-circuited or disconnected.
⇒ Go to **VERRUN CLUTCH SOLENOID VALVE (DTC: 1203), AT-168.**

7th judgement flicker is longer than others.

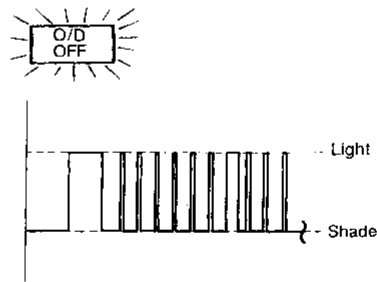

SAT449F

Torque converter clutch solenoid valve circuit is short-circuited or disconnected.
⇒ Go to **TORQUE CONVERTER CLUTCH SOLENOID VALVE (DTC: 1204), AT-132.**

ON BOARD DIAGNOSTIC SYSTEM DESCRIPTION

CONSULT (Cont'd)

O/D OFF indicator lamp:

8th judgement flicker is longer than others.

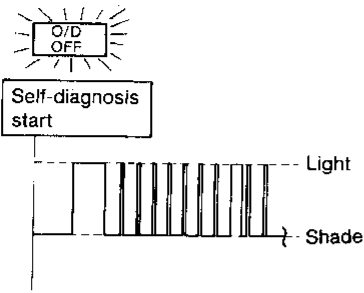

SAT451F

A/T fluid temperature sensor is disconnected or TCM power source circuit is damaged.
 ⇒ Go to A/T FLUID TEMPERATURE SENSOR AND TCM POWER SOURCE, AT-173.

9th judgement flicker is longer than others.

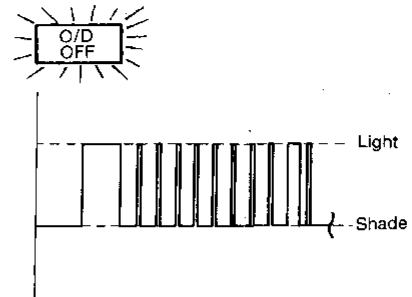

SAT453F

Engine speed signal circuit is short-circuited or disconnected.
 ⇒ Go to ENGINE SPEED SIGNAL (DTC: 1207), AT-101.

10th judgement flicker is longer than others.

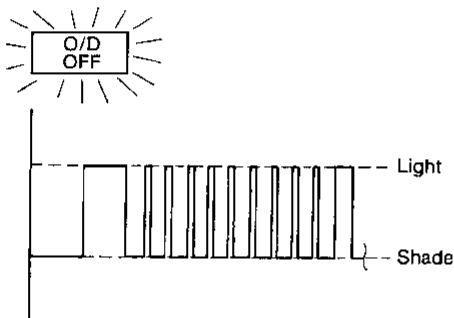

SAT455F

Line pressure solenoid valve circuit is short-circuited or disconnected.
 ⇒ Go to LINE PRESSURE SOLENOID VALVE (DTC: 1205), AT-145.

Flickers as shown below.

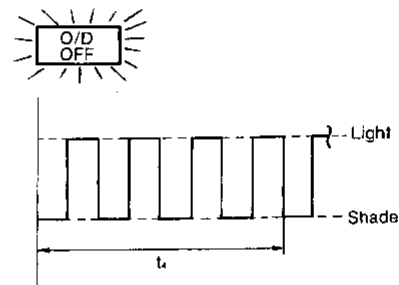

SAT457F

Battery power is low.
 Battery has been disconnected for a long time.
 Battery is connected conversely.
 (When reconnecting TCM connectors. — This is not a problem.)

Does not come on.

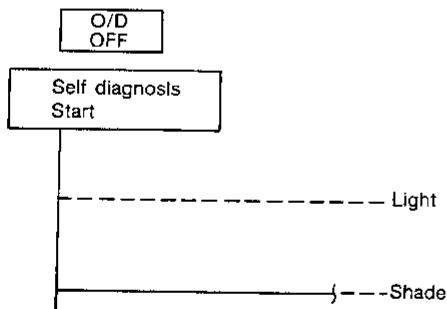

SAT414G

Inhibitor switch, overdrive control switch or throttle position switch circuit is disconnected or TCM is damaged.
 ⇒ Go to 21. TCM Self-diagnosis Does Not Activate (INHIBITOR, OVERDRIVE CONTROL AND THROTTLE POSITION SWITCHES), AT-212.

$t_1 = 2.5$ seconds $t_2 = 2.0$ seconds $t_3 = 1.0$ second $t_4 = 1.0$ second

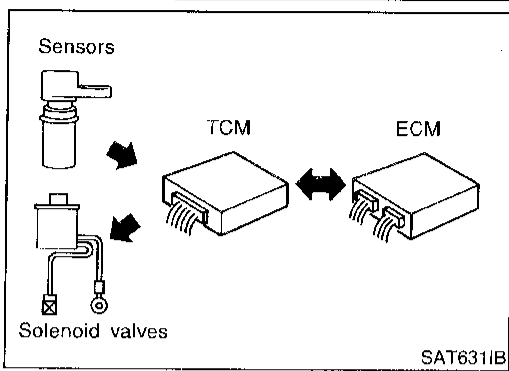

Introduction

NAAT0019

The TCM receives a signal from the vehicle speed sensor, throttle position sensor or inhibitor switch and provides shift control or lock-up control via A/T solenoid valves.

The TCM also communicates with the ECM by means of a signal sent from sensing elements used with the OBD-related parts of the A/T system for malfunction-diagnostic purposes. The TCM is capable of diagnosing malfunctioning parts while the ECM can store malfunctions in its memory.

Input and output signals must always be correct and stable in the operation of the A/T system. The A/T system must be in good operating condition and be free of valve seizure, solenoid valve malfunction, etc.

It is much more difficult to diagnose a problem that occurs intermittently rather than continuously. Most intermittent problems are caused by poor electric connections or improper wiring. In this case, careful checking of suspected circuits may help prevent the replacement of good parts.

A visual check only may not find the cause of the problems. A road test with CONSULT (or GST) or a circuit tester connected should be performed. Follow the "Work Flow". Refer to AT-52.

Before undertaking actual checks, take a few minutes to talk with a customer who approaches with a driveability complaint. The customer can supply good information about such problems, especially intermittent ones. Find out what symptoms are present and under what conditions they occur. A "Diagnostic Worksheet" like the example (AT-50) should be used.

Start your diagnosis by looking for "conventional" problems first. This will help troubleshoot driveability problems on an electronically controlled engine vehicle.

Also check related Service bulletins.

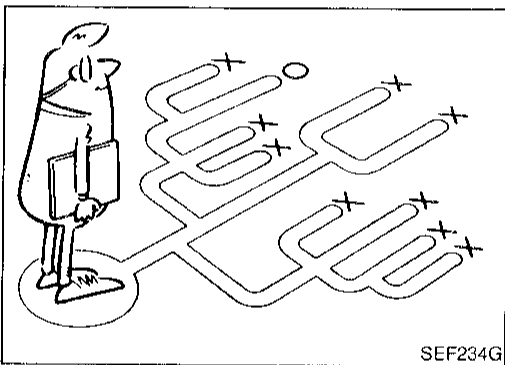
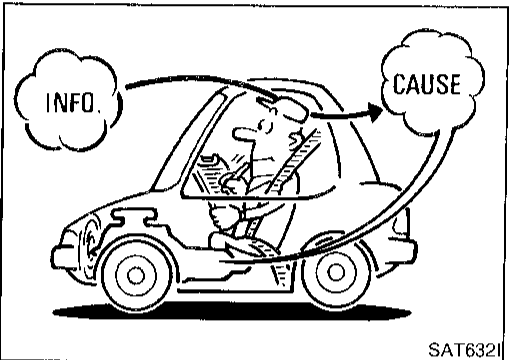

TROUBLE DIAGNOSIS — INTRODUCTION

Introduction (Cont'd)

DIAGNOSTIC WORKSHEET Information From Customer KEY POINTS

—NAAT0019S01

NAAT0018S0101

WHAT Vehicle & A/T model

WHEN..... Date, Frequencies

WHERE..... Road conditions

HOW..... Operating conditions, Symptoms

Customer name MR/MS	Model & Year	VIN
Trans. model	Engine	Mileage
Incident Date	Manuf. Date	In Service Date
Frequency	<input type="checkbox"/> Continuous <input type="checkbox"/> Intermittent (times a day)	
Symptoms	<input type="checkbox"/> Vehicle does not move. (<input type="checkbox"/> Any position <input type="checkbox"/> Particular position)	
	<input type="checkbox"/> No up-shift (<input type="checkbox"/> 1st → 2nd <input type="checkbox"/> 2nd → 3rd <input type="checkbox"/> 3rd → O/D)	
	<input type="checkbox"/> No down-shift (<input type="checkbox"/> O/D → 3rd <input type="checkbox"/> 3rd → 2nd <input type="checkbox"/> 2nd → 1st)	
	<input type="checkbox"/> Lockup malfunction	
	<input type="checkbox"/> Shift point too high or too low.	
	<input type="checkbox"/> Shift shock or slip (<input type="checkbox"/> N → D <input type="checkbox"/> Lockup <input type="checkbox"/> Any drive position)	
	<input type="checkbox"/> Noise or vibration	
	<input type="checkbox"/> No kickdown	
	<input type="checkbox"/> No pattern select	
	<input type="checkbox"/> Others ()	
O/D OFF indicator lamp	Blinks for about 8 seconds.	
	<input type="checkbox"/> Continuously lit	<input type="checkbox"/> Not lit
Malfunction indicator lamp (MIL)	<input type="checkbox"/> Continuously lit	<input type="checkbox"/> Not lit

GI

MA

EM

LC

EC

FE

CL

MT

AT

TF

PD

AX

SU

BR

ST

RS

BT

HA

SC

EL

IDX

TROUBLE DIAGNOSIS — INTRODUCTION

Introduction (Cont'd)

Diagnostic Worksheet

-NAAT0019SD102

1.	<input type="checkbox"/> Read the Fail-safe Remarks and listen to customer complaints.	AT-6
2.	<input type="checkbox"/> CHECK A/T FLUID <input type="checkbox"/> Leakage (Follow specified procedure) <input type="checkbox"/> Fluid condition <input type="checkbox"/> Fluid level	AT-54
3.	Perform STALL TEST and LINE PRESSURE TEST. <input type="checkbox"/> Stall test — Mark possible damaged components/others. <div style="display: flex; justify-content: space-between;"> <div style="width: 45%;"> <input type="checkbox"/> Torque converter one-way clutch <input type="checkbox"/> Reverse clutch <input type="checkbox"/> Forward clutch <input type="checkbox"/> Overrun clutch <input type="checkbox"/> Forward one-way clutch </div> <div style="width: 45%;"> <input type="checkbox"/> Low & reverse brake <input type="checkbox"/> Low one-way clutch <input type="checkbox"/> Engine <input type="checkbox"/> Line pressure is low <input type="checkbox"/> Clutches and brakes except high clutch and brake band are OK </div> </div> <input type="checkbox"/> Pressure test — Suspected parts:	AT-54, AT-57
4.	<input type="checkbox"/> Perform all ROAD TEST and mark required procedures.	AT-58
4-1.	Check before engine is started. <input type="checkbox"/> SELF-DIAGNOSTIC PROCEDURE - Mark detected items. <input type="checkbox"/> Inhibitor switch, AT-86. <input type="checkbox"/> A/T fluid temperature sensor, AT-91. <input type="checkbox"/> Vehicle speed sensor-A/T (Revolution sensor), AT-96. <input type="checkbox"/> Engine speed signal, AT-101. <input type="checkbox"/> Torque converter clutch solenoid valve, AT-132. <input type="checkbox"/> Line pressure solenoid valve, AT-145. <input type="checkbox"/> Shift solenoid valve A, AT-151. <input type="checkbox"/> Shift solenoid valve B, AT-156. <input type="checkbox"/> Throttle position sensor, AT-161. <input type="checkbox"/> Overrun clutch solenoid valve, AT-168. <input type="checkbox"/> A/T fluid temperature sensor and TCM power source, AT-173. <input type="checkbox"/> Vehicle speed sensor-MTR, AT-178. <input type="checkbox"/> Battery <input type="checkbox"/> Others	AT-59
4-2.	Check at idle <input type="checkbox"/> 1. O/D OFF Indicator Lamp Does Not Come On, AT-185. <input type="checkbox"/> 2. Engine Cannot Be Started In "P" And "N" Position, AT-187. <input type="checkbox"/> 3. In "P" Position, Vehicle Moves Forward Or Backward When Pushed, AT-188. <input type="checkbox"/> 4. In "N" Position, Vehicle Moves, AT-189. <input type="checkbox"/> 5. Large Shock. "N" → "R" Position, AT-191. <input type="checkbox"/> 6. Vehicle Does Not Creep Backward In "R" Position, AT-192. <input type="checkbox"/> 7. Vehicle Does Not Creep Forward In "D", "2" Or "1" Position, AT-194.	AT-60

Work Flow

HOW TO PERFORM TROUBLE DIAGNOSES FOR QUICK AND ACCURATE REPAIR

NAAT0020

NAAT0020S01

A good understanding of the malfunction conditions can make troubleshooting faster and more accurate.

In general, each customer feels differently about a problem. It is important to fully understand the symptoms or conditions for a customer complaint.

Make good use of the two sheets provided, "INFORMATION FROM CUSTOMER" (AT-49) and "DIAGNOSTIC WORKSHEET" (AT-50), to perform the best troubleshooting possible.

WORK FLOW CHART

-NAAT0020S02

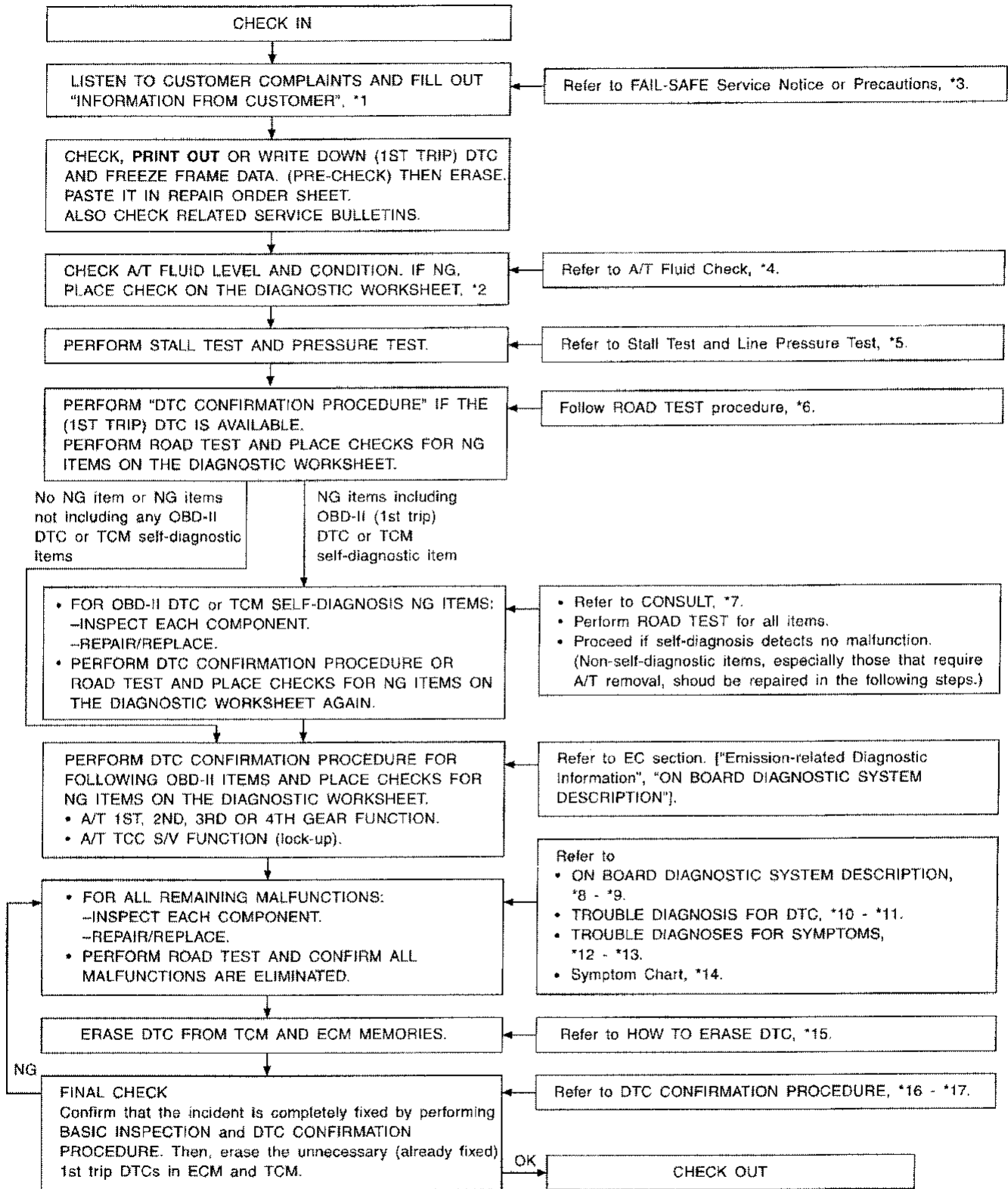

- *1: AT-49
- *2: AT-50
- *3: AT-6
- *4: AT-54
- *5: AT-54, 57
- *6: AT-58

- *7: AT-35
- *8: AT-31
- *9: AT-45
- *10: AT-86
- *11: AT-178

- *12: AT-182
- *13: AT-212
- *14: AT-69
- *15: AT-33
- *16: AT-87
- *17: AT-178

A/T Fluid Check

NAAT0021

FLUID LEAKAGE CHECK

NAAT0021S01

1. Clean area suspected of leaking. — for example, mating surface of converter housing and transmission case.
2. Start engine, apply foot brake, place selector lever in "D" position and wait a few minutes.
3. Stop engine.
4. Check for fresh leakage.

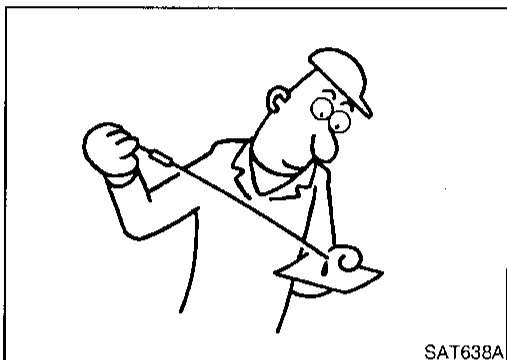

SAT638A

FLUID CONDITION CHECK

NAAT0021S02

Fluid color	Suspected problem
Dark or black with burned odor	Wear of frictional material
Milky pink	Water contamination — Road water entering through filler tube or breather
Varnished fluid, light to dark brown and tacky	Oxidation — Over or under filling, — Overheating

FLUID LEVEL CHECK

NAAT0021S03

Refer to MA section ("Checking A/T Fluid", "CHASSIS AND BODY MAINTENANCE").

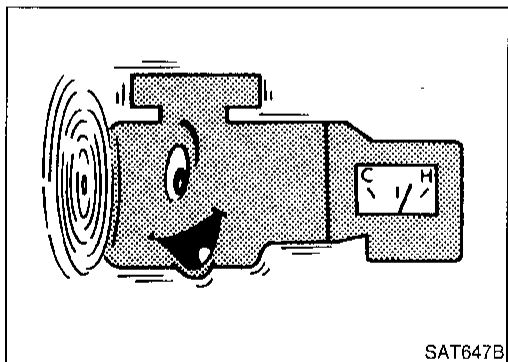

SAT647B

Stall Test

NAAT0022

STALL TEST PROCEDURE

NAAT0022S01

1. Check A/T and engine fluid levels. If necessary, add.
2. Drive vehicle for approx. 10 minutes or until engine oil and ATF reach operating temperature.

ATF operating temperature:

50 - 80°C (122 - 176°F)

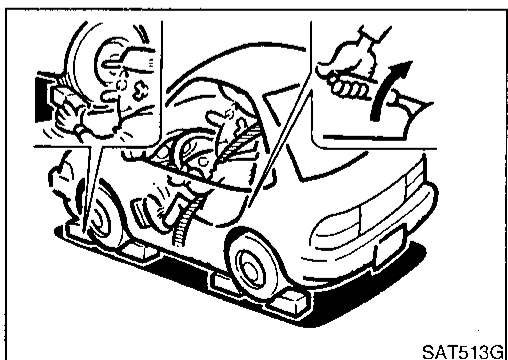

SAT513G

3. Set parking brake and block wheels.
 4. Install a tachometer where it can be seen by driver during test.
- It is good practice to put a mark on point of specified engine rpm on indicator.

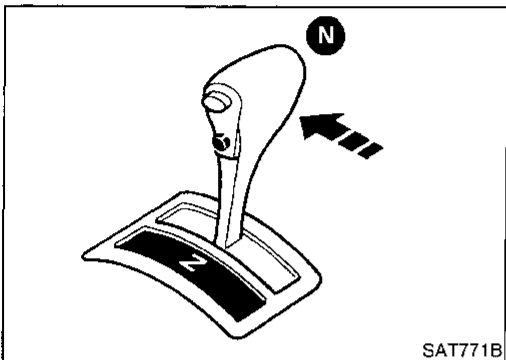
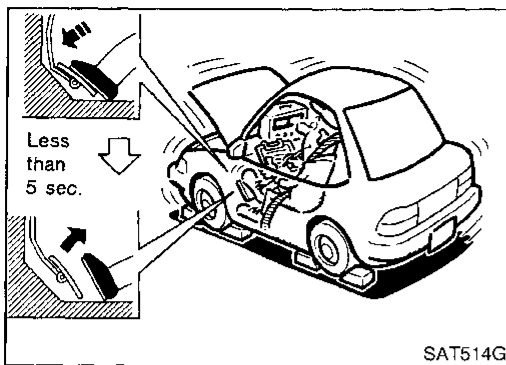

5. Start engine, apply foot brake, and place selector lever in "D" position.
6. Accelerate to wide-open throttle gradually while applying foot brake.
7. Quickly note the engine stall revolution and immediately release throttle.
 - **During test, never hold throttle wide-open for more than 5 seconds.**

Stall revolution:
2,440 - 2,640 rpm
8. Move selector lever to "N" position.
9. Cool off ATF.
 - **Run engine at idle for at least one minute.**
10. Repeat steps 5 through 9 with selector lever in "2", "1" and "R" positions.

JUDGEMENT OF STALL TEST

The test result and possible damaged components relating to each result are shown in the illustration. In order to pinpoint the possible damaged components, follow the WORK FLOW shown in AT-52.

NOTE:

Stall revolution is too high in "D" or "2" position:

- Slippage occurs in 1st gear but not in 2nd and 3rd gears. Low one-way clutch slippage
- Slippage occurs at the following gears:
1st through 3rd gears in "D" position and engine brake functions.
1st and 2nd gears in "2" position and engine brake functions with accelerator pedal released (fully closed throttle). Forward clutch or forward one-way clutch slippage

Stall revolution is too high in "R" position:

- Engine brake does not function in "1" position. Low & reverse brake slippage
- Engine brake functions in "1" position. Reverse clutch slippage

Stall revolution within specifications:

- Vehicle does not achieve speed of more than 80 km/h. One-way clutch seizure in torque converter housing

CAUTION:

Be careful since automatic fluid temperature increases abnormally.

- Slippage occurs in 3rd and 4th gears in "D" position. High clutch slippage
- Slippage occurs in 2nd and 4th gear in "D" position. Brake band slippage

Stall revolution less than specifications:

- Poor acceleration during starts. One-way clutch seizure in torque converter

GI
MA
EM
LC
EC
FE
CL
MT
AT
TF
PD
AX
SU
BR
ST
RS
BT
HA
SC
EL
IDX

TROUBLE DIAGNOSIS — BASIC INSPECTION

Stall Test (Cont'd)

Selector lever position	Judgement		
	L	O	H
D	L	O	H
2	L	O	H
1	L	O	O
R	L	H	H

- O : Stall revolution is normal.
- H : Stall revolution is higher than specified.
- L : Stall revolution is lower than specified.

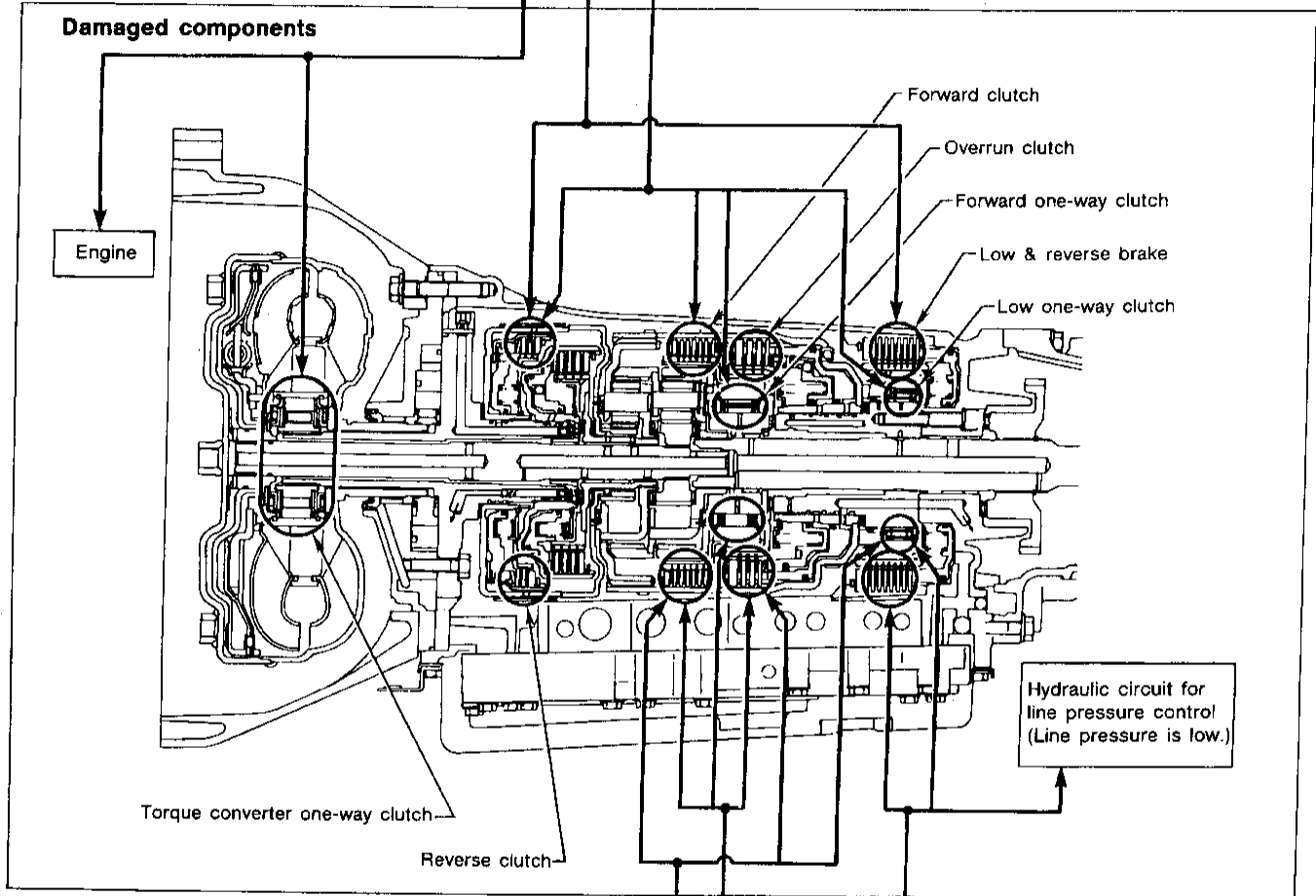

D	H	H	H	O
2	H	H	H	O
1	O	H	H	O
R	O	O	H	O
Selector lever position	Judgement			

SAT392H

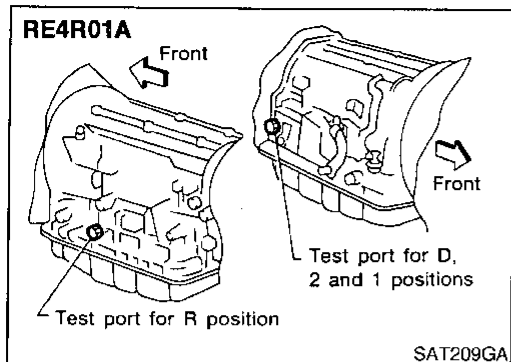

Line Pressure Test

- Location of pressure test ports.
- Always replace line pressure plugs as they are self-sealing bolts.

NAAT0023

GI

MA

EM

LC

EC

NAAT0023S01

LINE PRESSURE TEST PROCEDURE

1. Check A/T and engine fluid levels. If necessary, add fluid.
2. Drive vehicle for approx. 10 minutes or until engine oil and ATF reach operating temperature.

ATF operating temperature:
50 - 80°C (122 - 176°F)

CL

MT

AT

3. Install pressure gauge to corresponding line pressure port.

TF

PD

AX

SU

BR

ST

RS

BT

HA

SC

EL

IDX

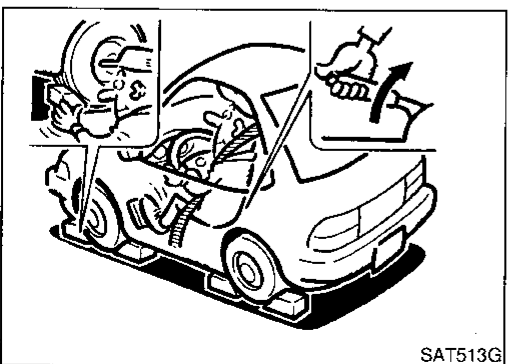
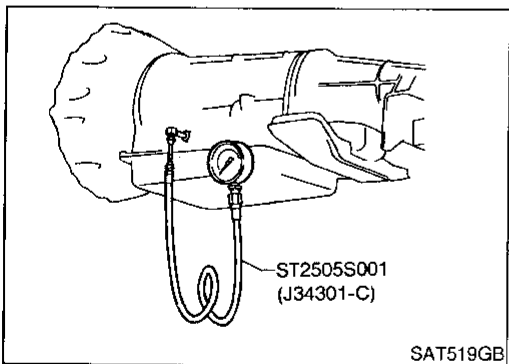
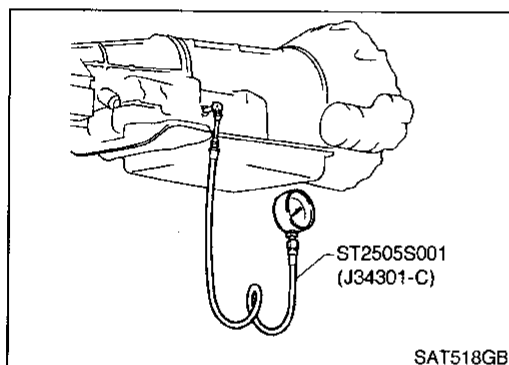
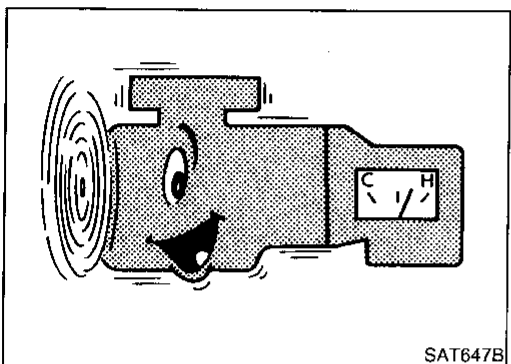

4. Set parking brake and block wheels.
 - Continue to depress brake pedal fully while line pressure test is being performed at stall speed.

TROUBLE DIAGNOSIS — BASIC INSPECTION

Line Pressure Test (Cont'd)

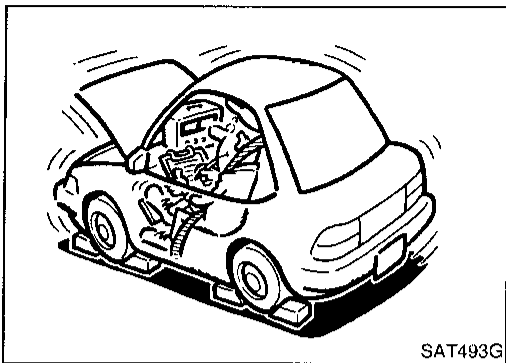

5. Start engine and measure line pressure at idle and stall speed.
 - **When measuring line pressure at stall speed, follow the stall test procedure.**

Line pressure:

Refer to SDS, AT-307.

JUDGEMENT OF LINE PRESSURE TEST

NAAT0023502

Judgement		Suspected parts
At idle	Line pressure is low in all positions.	<ul style="list-style-type: none"> ● Oil pump wear ● Control piston damage ● Pressure regulator valve or plug sticking ● Spring for pressure regulator valve damaged ● Fluid pressure leakage between oil strainer and pressure regulator valve ● Clogged strainer
	Line pressure is low in particular position.	<ul style="list-style-type: none"> ● Fluid pressure leakage between manual valve and particular clutch ● For example, line pressure is: <ul style="list-style-type: none"> — Low in "R" and "1" positions, but — Normal in "D" and "2" positions. Then, fluid leakage exists at or around low and reverse brake circuit. Refer to "CLUTCH AND BRAKE CHART", AT-22.
	Line pressure is high.	<ul style="list-style-type: none"> ● Mal-adjustment of throttle position sensor ● Fluid temperature sensor damaged ● Line pressure solenoid valve sticking ● Short circuit of line pressure solenoid valve circuit ● Pressure modifier valve sticking ● Pressure regulator valve or plug sticking ● Open in dropping resistor circuit
At stall speed	Line pressure is low.	<ul style="list-style-type: none"> ● Mal-adjustment of throttle position sensor ● Line pressure solenoid valve sticking ● Short circuit of line pressure solenoid valve circuit ● Pressure regulator valve or plug sticking ● Pressure modifier valve sticking ● Pilot valve sticking

ROAD TEST PROCEDURE

1. Check before engine is started.



2. Check at idle.



3. Cruise test.

SAT786A

Road Test DESCRIPTION

NAAT0024

NAAT0024S01

- The purpose of the test is to determine overall performance of A/T and analyze causes of problems.
- The road test consists of the following three parts:
 - a) Check before engine is started
 - b) Check at idle
 - c) Cruise test

TROUBLE DIAGNOSIS — BASIC INSPECTION

Road Test (Cont'd)

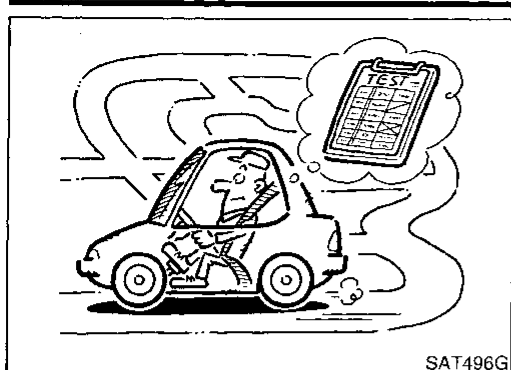

- Before road test, familiarize yourself with all test procedures and items to check.
- Conduct tests on all items until specified symptom is found. Troubleshoot items which check out No Good after road test. Refer to "ON BOARD DIAGNOSTIC SYSTEM DESCRIPTION" and "TROUBLE DIAGNOSES FOR SYMPTOMS", AT-31 - AT-45 and AT-182 - AT-212.

1. CHECK BEFORE ENGINE IS STARTED

NAAT0024502

1	CHECK O/D OFF INDICATOR LAMP
<ol style="list-style-type: none"> 1. Park vehicle on flat surface. 2. Move selector lever to "P" position. 3. Turn ignition switch to "OFF" position. Wait at least 5 seconds. 	
<p>OVERDRIVE ON/OFF →</p> <p>P</p> <p>SAT9671</p>	
<ol style="list-style-type: none"> 4. Turn ignition switch to "ON" position. (Do not start engine.) 5. Does O/D OFF indicator lamp come on for about 2 seconds? 	
<p>O/D OFF indicator lamp</p> <p>SAT325IA</p>	
Yes or No	
Yes	▶ GO TO 2.
No	▶ Go to "1. O/D OFF Indicator Lamp Does Not Come On", AT-185.

2	CHECK O/D OFF INDICATOR LAMP
Does O/D OFF indicator lamp flicker for about 8 seconds?	
<p>O/D OFF indicator lamp</p> <p>SAT325IA</p>	
Yes or No	
Yes	▶ Perform self-diagnosis. Refer to SELF-DIAGNOSIS PROCEDURE, AT-44.
No	▶ GO TO 3.

3	CHECK NG ITEM
<ol style="list-style-type: none"> 1. Turn ignition switch to "OFF" position. 2. Perform self-diagnosis and note NG items. Refer to SELF-DIAGNOSIS PROCEDURE, AT-44. 	
▶ Go to "2. Check at idle", AT-60.	

TROUBLE DIAGNOSIS — BASIC INSPECTION

Road Test (Cont'd)

2. CHECK AT IDLE

=NAAT0024S03

1	CHECK ENGINE START
<ol style="list-style-type: none"> 1. Park vehicle on flat surface. 2. Turn ignition switch to "OFF" position. 3. Move selector lever to "P" or "N" position. 4. Turn ignition switch to start position. 5. Is engine started? 	
Yes or No	
Yes	▶ GO TO 2.
No	▶ Go to "2. Engine Cannot Be Started In "P" and "N" Position", AT-187.

4	CHECK VEHICLE MOVE
<ol style="list-style-type: none"> 1. Apply parking brake. 2. Move selector lever to "N" position. 3. Turn ignition switch to "START" position and start engine. 4. Release parking brake. 5. Does vehicle move forward or backward? 	
Yes or No	
Yes	▶ Go to "4. In "N" Position, Vehicle Moves", AT-189.
No	▶ GO TO 5.

2	CHECK ENGINE START
<ol style="list-style-type: none"> 1. Turn ignition switch to "OFF" position. 2. Move selector lever to "D", "1", "2" or "R" position. 3. Turn ignition switch to start position. 4. Is engine started? 	
Yes or No	
Yes	▶ Go to "2. Engine Cannot Be Started In "P" and "N" Position", AT-187.
No	▶ GO TO 3.

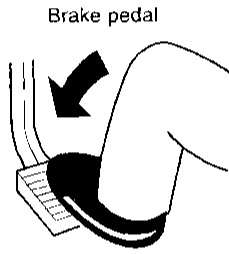
5	CHECK SHIFT SHOCK
<ol style="list-style-type: none"> 1. Apply foot brake. 2. Move selector lever to "R" position. 3. Is there large shock when changing from "N" to "R" position? 	
Yes or No	
	
SAT082J	
Yes or No	
Yes	▶ Go to "5. Large Shock. "N" → "R" Position", AT-191.
No	▶ GO TO 6.

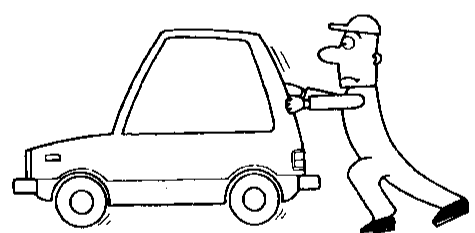
3	CHECK VEHICLE MOVE
<ol style="list-style-type: none"> 1. Turn ignition switch to "OFF" position. 2. Move selector lever to "P" position. 3. Release parking brake. 4. Push vehicle forward or backward. 5. Does vehicle move when it is pushed forward or backward? 	
Yes or No	
	
SAT796A	
Yes or No	
Yes	▶ Go to "3. In "P" Position, Vehicle Moves Forward Or Backward When Pushed", AT-188.
No	▶ GO TO 4.

6	CHECK VEHICLE MOVE
<ol style="list-style-type: none"> 1. Release foot brake for several seconds. 2. Does vehicle creep backward when foot brake is released? 	
Yes or No	
Yes	▶ GO TO 7.
No	▶ Go to "6. Vehicle Does Not Creep Backward In "R" Position", AT-192.

7	CHECK VEHICLE MOVE
<ol style="list-style-type: none"> 1. Move selector lever to "D", "2" and "1" position and check if vehicle creeps forward. 2. Does vehicle creep forward in all three positions? 	
Yes or No	
Yes	▶ Go to "3. Cruise test", AT-61.
No	▶ Go to "7. Vehicle Does Not Creep Forward In "D", "2" Or "1" Position", AT-194.

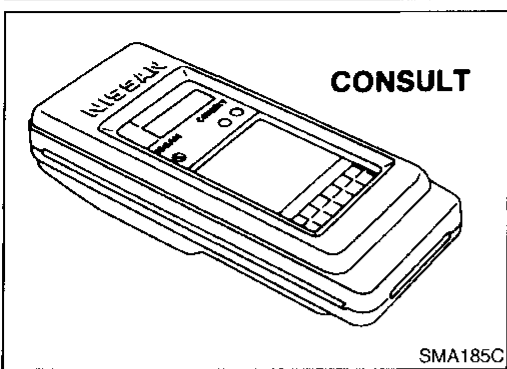

3. CRUISE TEST

- Check all items listed in Parts 1 through 3.

NAAT0024S04

GI

With CONSULT

- Using CONSULT, conduct a cruise test and record the result.
- Print the result and ensure that shifts and lock-ups take place as per "Shift Schedule".

NAAT0024S0401

MA

EM

LC

EC

FE

CL

MT

AT

TF

PD

AX

SU

BR

ST

RS

BT

HA

SC

EL

IDX

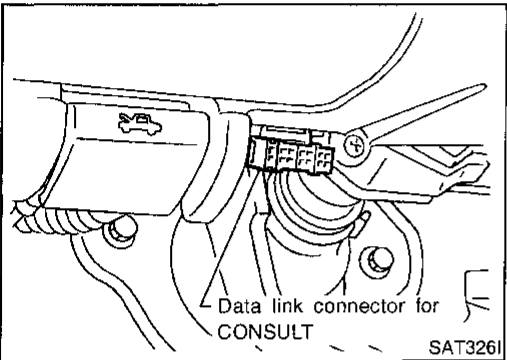

CONSULT Setting Procedure

NAAT0024S0402

1. Turn off ignition switch.
2. Connect "CONSULT" to Data link connector for CONSULT. Data link connector for CONSULT is located in instrument lower panel on driver side.

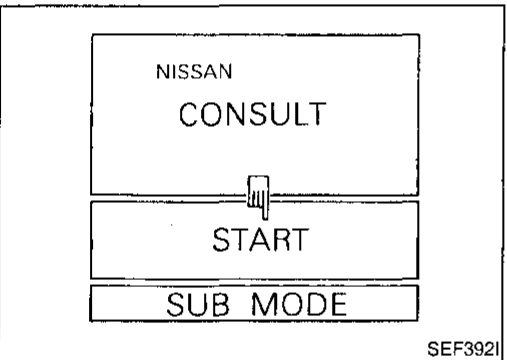

3. Turn on ignition switch.
4. Touch "START".

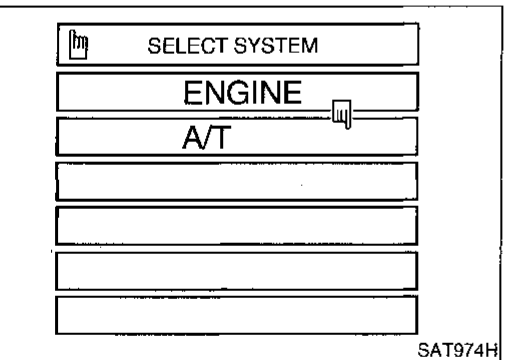

5. Touch "A/T".

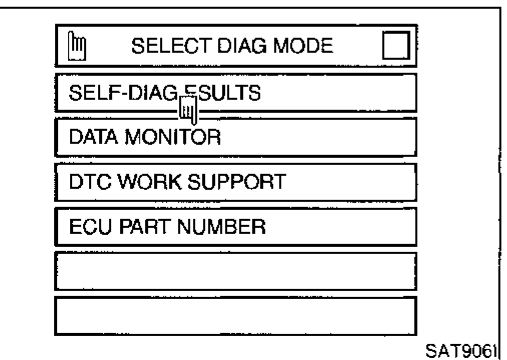

6. Touch "DATA MONITOR".

TROUBLE DIAGNOSIS — BASIC INSPECTION

Road Test (Cont'd)

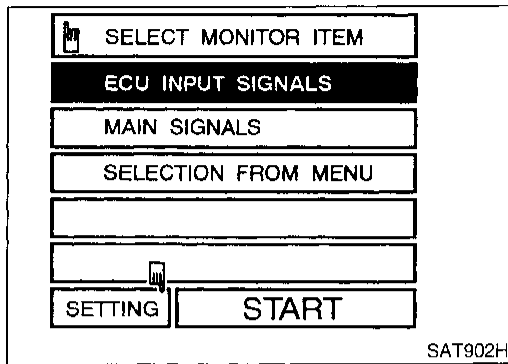

7. Touch "SETTING" to set recording condition.

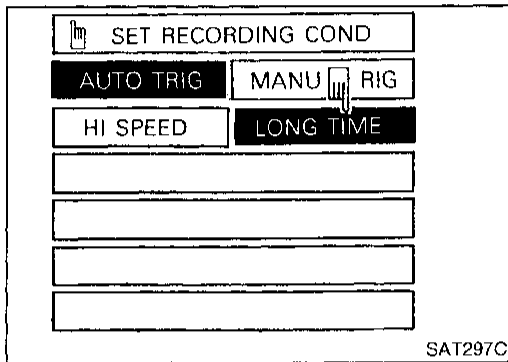

8. Touch "LONG TIME" and "ENTER" key.

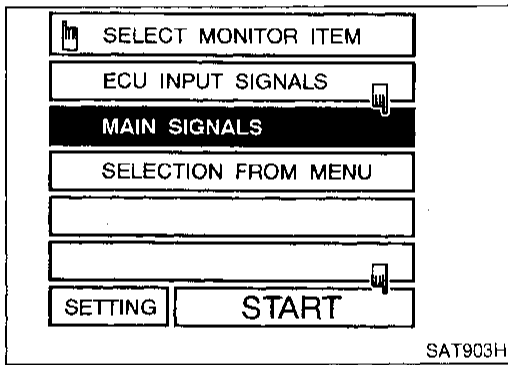

9. Go back to SELECT MONITOR ITEM and touch "MAIN SIGNALS".

10. Touch "START".

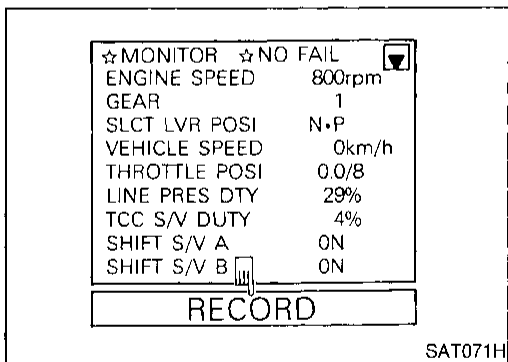

11. When performing cruise test, touch "RECORD".

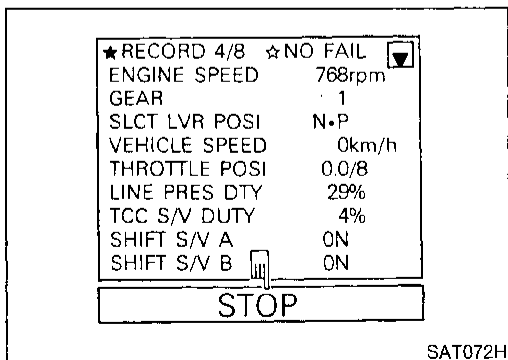

12. After finishing cruise test part 1, touch "STOP".

GI
 MA
 EM
 LC
 EC
 FE
 CL
 MT
 AT
 TF
 PD
 AX
 SU
 BR
 ST
 RS
 BT
 HA
 SC
 EL
 IDX

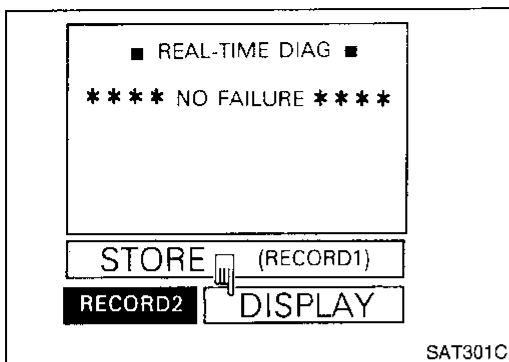

13. Touch "DISPLAY".

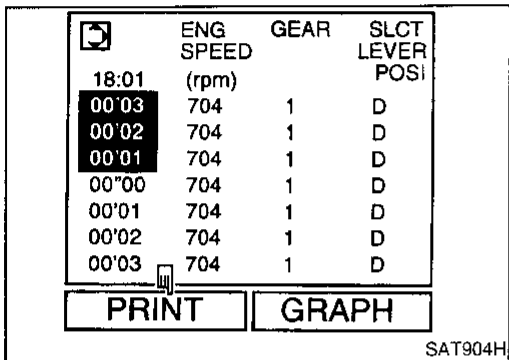

14. Touch "PRINT".

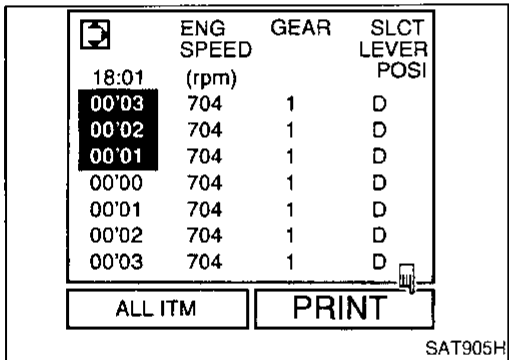

15. Touch "PRINT" again.

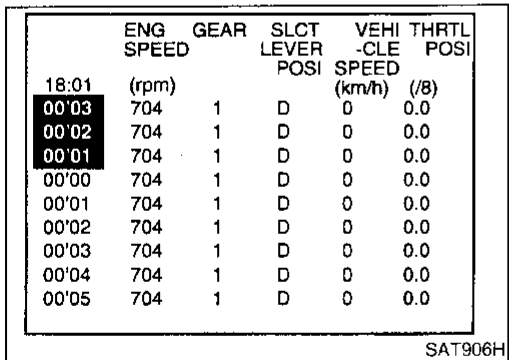

16. Check the monitor data printed out.

17. Continue cruise test part 2 and 3.

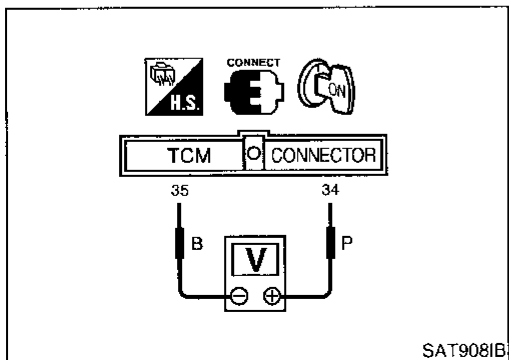

⊗ Without CONSULT

- Throttle position can be checked by voltage across terminals 34 and 35 of TCM.

NAAT002450403

TROUBLE DIAGNOSIS — BASIC INSPECTION

Road Test (Cont'd)

Cruise Test — Part 1

=NAA70024S0404

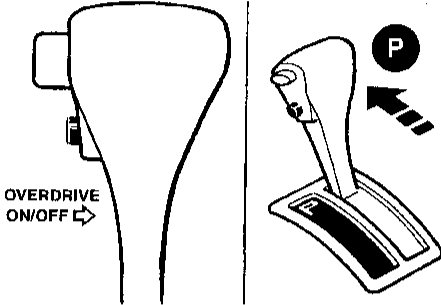
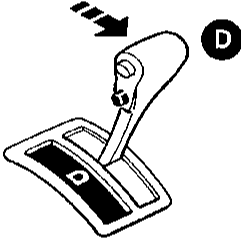
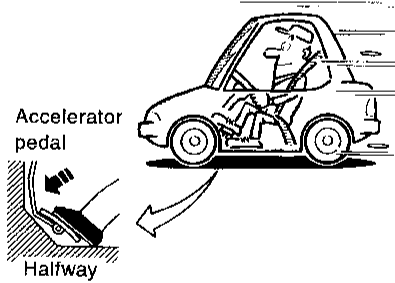
1	CHECK STARTING GEAR (D₁) POSITION
<p>1. Drive vehicle for approx. 10 minutes to warm engine oil and ATF up to operating temperature. ATF operating temperature: 50 - 80°C (122 - 176°F)</p> <p>2. Park vehicle on flat surface. 3. Set overdrive control switch to "ON" position. 4. Move selector lever to "P" position.</p>	
	
SAT001J	
<p>5. Start engine. 6. Move selector lever to "D" position.</p>	
	
SAT952I	
<p>7. Accelerate vehicle by constantly depressing accelerator pedal halfway.</p>	
	
SAT953I	
<p>8. Does vehicle start from D₁? <input type="checkbox"/> Read gear position.</p>	
Yes or No	
Yes	▶ GO TO 2.
No	▶ Go to "8. Vehicle Cannot Be Started From D ₁ ", AT-196.

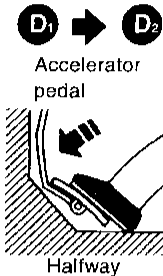
2	CHECK SHIFT UP (D₁ TO D₂)
<p>Does A/T shift from D₁ to D₂ at the specified speed? <input type="checkbox"/> Read gear position, throttle opening and vehicle speed. Specified speed when shifting from D₁ to D₂: Refer to Shift schedule, AT-307.</p>	
	
SAT954I	
Yes or No	
Yes	▶ GO TO 3.
No	▶ Go to "9. A/T Does Not Shift: D ₁ → D ₂ or Does Not Kickdown: D ₄ → D ₂ ", AT-198.

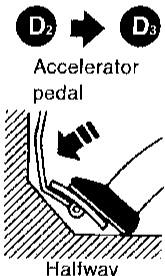
3	CHECK SHIFT UP (D₂ TO D₃)
<p>Does A/T shift from D₂ to D₃ at the specified speed? <input type="checkbox"/> Read gear position, throttle opening and vehicle speed. Specified speed when shifting from D₂ to D₃: Refer to Shift schedule, AT-307.</p>	
	
SAT955I	
Yes or No	
Yes	▶ GO TO 4.
No	▶ Go to "10. A/T Does Not Shift: D ₂ → D ₃ ", AT-200.

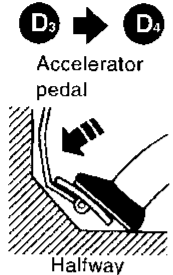
4	CHECK SHIFT UP (D₃ TO D₄)
<p>Does A/T shift from D₃ to D₄ at the specified speed? Ⓢ Read gear position, throttle opening and vehicle speed. Specified speed when shifting from D₃ to D₄: Refer to Shift schedule, AT-307.</p>	
	
SAT956I	
Yes or No	
Yes	▶ GO TO 5.
No	▶ Go to "11. A/T Does Not Shift: D ₃ → D ₄ ", AT-202.

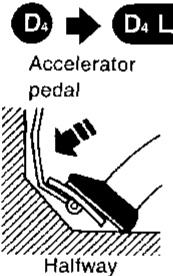
5	CHECK LOCK-UP (D₄ TO D₄ L/U)
<p>Does A/T perform lock-up at the specified speed? Ⓢ Read vehicle speed, throttle position when lock-up duty becomes 94%. Specified speed when lock-up occurs: Refer to Shift schedule, AT-307.</p>	
	
SAT957I	
Yes or No	
Yes	▶ GO TO 6.
No	▶ Go to "12. A/T Does Not Perform Lock-up", AT-204.

6	CHECK HOLD LOCK-UP
<p>Does A/T hold lock-up condition for more than 30 seconds?</p>	
Yes or No	
Yes	▶ GO TO 7.
No	▶ Go to "13. A/T Does Not Hold Lock-up Condition", AT-205.

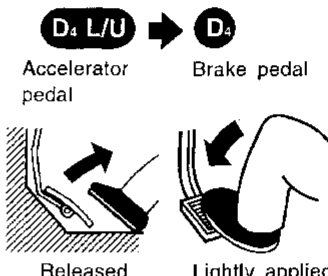
7	CHECK LOCK-UP OFF (D₄ L/U TO D₄)
<p>1. Release accelerator pedal. 2. Is lock-up released when accelerator pedal is released?</p>	
	
SAT958I	
Yes or No	
Yes	▶ GO TO 8.
No	▶ Go to "14. Lock-up Is Not Released", AT-206.

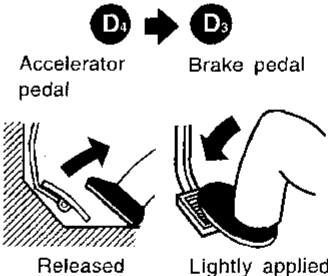
8	CHECK SHIFT DOWN (D₄ TO D₃)
<p>1. Decelerate vehicle by applying foot brake lightly. 2. Does engine speed return to idle smoothly when A/T is shifted from D₄ to D₃? Ⓢ Read gear position and engine speed.</p>	
	
SAT959I	
Yes or No	
Yes	▶ 1. Stop vehicle. 2. Go to "Cruise test — Part 2", AT-66.
No	▶ Go to "15. Engine Speed Does Not Return To Idle (Light Braking D ₄ → D ₃)", AT-207.

GI
MA
EM
LC
EC
FE
CL
MT
AT
TF
PD
AX
SU
BR
ST
RS
BT
HA
SC
EL
IDX

TROUBLE DIAGNOSIS — BASIC INSPECTION

Road Test (Cont'd)

Cruise Test — Part 2

=NAAT0024S0406

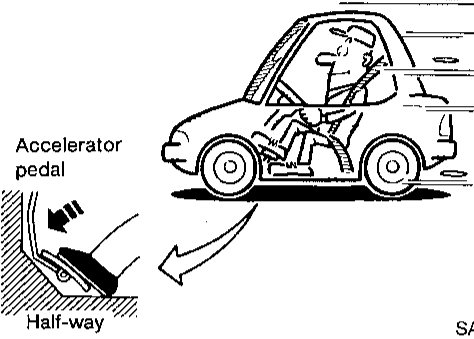
1	CHECK STARTING GEAR (D₁) POSITION
<ol style="list-style-type: none"> 1. Confirm overdrive control switch is in "ON" position. 2. Confirm selector lever is in "D" position. 3. Accelerate vehicle by half throttle again. 4. Does vehicle start from D₁? <p>Ⓟ Read gear position.</p>	
	
SAT495G	
Yes or No	
Yes	▶ GO TO 2.
No	▶ Go to "16. Vehicle Does Not Start From D ₁ ", AT-208.

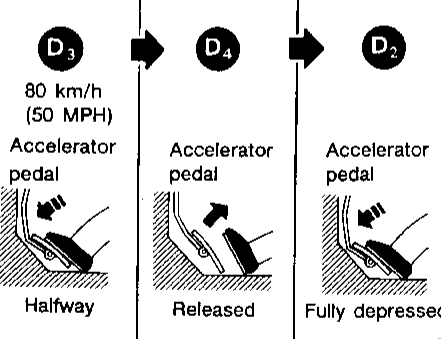
2	CHECK SHIFT UP AND SHIFT DOWN (D₃ TO D₄ TO D₂)
<ol style="list-style-type: none"> 1. Accelerate vehicle to 80 km/h (50 MPH) as shown in illustration. 2. Release accelerator pedal and then quickly depress it fully. 3. Does A/T shift from D₄ to D₂ as soon as accelerator pedal is depressed fully? <p>Ⓟ Read gear position and throttle position.</p>	
	
SAT404H	
Yes or No	
Yes	▶ GO TO 3.
No	▶ Go to "9. A/T Does Not Shift: D ₃ → D ₄ Or Does Not Kickdown: D ₄ → D ₂ ", AT-198.

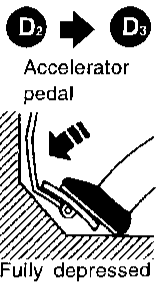
3	CHECK SHIFT UP (D₂ TO D₃)
<p>Does A/T shift from D₂ to D₃ at the specified speed?</p> <p>Ⓟ Read gear position, throttle position and vehicle speed.</p> <p>Specified speed when shifting from D₂ to D₃: Refer to Shift schedule, AT-307.</p>	
	
SAT960I	
Yes or No	
Yes	▶ GO TO 4.
No	▶ Go to "10. A/T Does Not Shift: D ₂ → D ₃ ", AT-200.

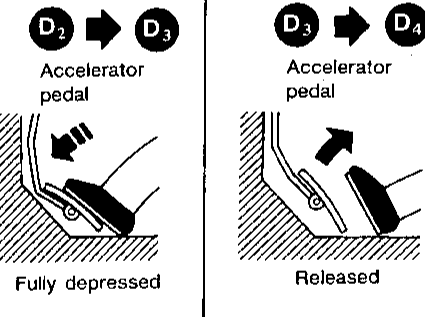
4	CHECK SHIFT UP (D₃ TO D₄) AND ENGINE BRAKE
<p>Release accelerator pedal after shifting from D₂ to D₃. Does A/T shift from D₃ to D₄ and does vehicle decelerate by engine brake?</p> <p>Ⓟ Read gear position, throttle position and vehicle speed</p>	
	
SAT405H	
Yes or No	
Yes	▶ 1. Stop vehicle. 2. Go to "Cruise test — Part 3", AT-67.
No	▶ Go to "11. A/T Does Not Shift: D ₃ → D ₄ ", AT-202.

Cruise Test — Part 3

-NAAT0024S0406

GI
MA
EM
LC
EC
FE
CL
MT
AT
TF
PD
AX
SU
BR
ST
RS
BT
HA
SC
EL
IDX

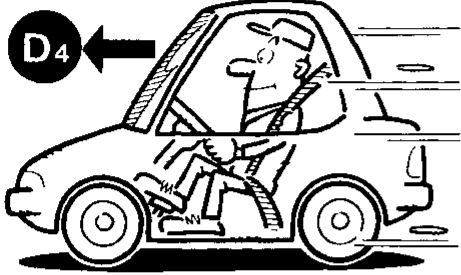
1	VEHICLE SPEED D₄ POSITION		
<ol style="list-style-type: none"> 1. Confirm overdrive control switch is in "ON" position. 2. Confirm selector lever is in "D" position. 3. Accelerate vehicle using half-throttle to D₄. 			
			
SAT812A			
<table border="1" style="margin-left: auto; margin-right: auto;"> <tr> <td style="width: 20px; text-align: center;">▶</td> <td>GO TO 2.</td> </tr> </table>		▶	GO TO 2.
▶	GO TO 2.		

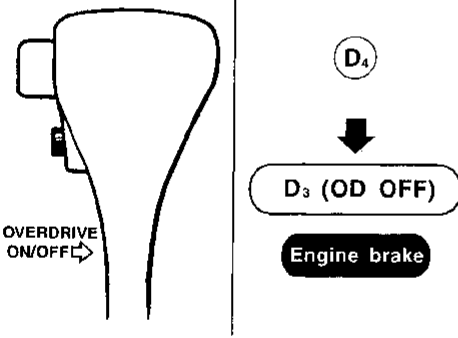
2	CHECK SHIFT DOWN (D₄ TO D₃)
<ol style="list-style-type: none"> 1. Release accelerator pedal. 2. Set overdrive control switch to "OFF" position while driving in D₄. 3. Does A/T shift from D₄ to D₃ (O/D OFF)? <p>Ⓜ Read gear position and vehicle speed.</p>	
	
SAT999I	
Yes or No	
Yes	▶ GO TO 3.
No	▶ Go to "17. A/T Does Not Shift: D ₄ → D ₃ , When Overdrive Control Switch "ON" → "OFF", AT-209.

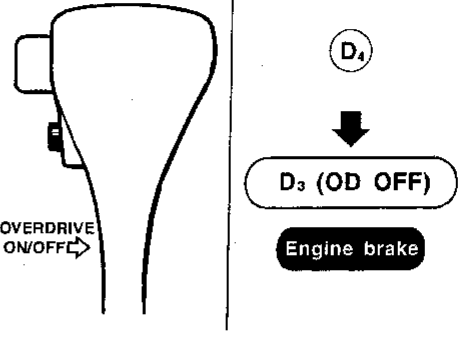
3	CHECK ENGINE BRAKE
Does vehicle decelerate by engine brake?	
	
SAT999I	
Yes or No	
Yes	▶ GO TO 4.
No	▶ Go to "15. Engine Speed Does Not Return To Idle (Light Braking D ₄ → D ₃)", AT-207.

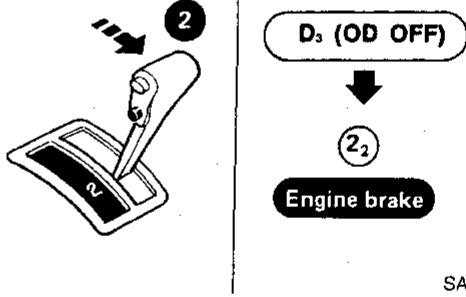
4	CHECK SHIFT DOWN (D₃ TO D₂)
<ol style="list-style-type: none"> 1. Move selector lever from "D" to "2" position while driving in D₃ (O/D OFF). 2. Does A/T shift from D₃ (O/D OFF) to 2₂? <p>Ⓜ Read gear position.</p>	
	
SAT791GA	
Yes or No	
Yes	▶ GO TO 5.
No	▶ Go to "18. A/T Does Not Shift: D ₃ → D ₂ , When Selector Lever "D" → "2" Position", AT-210.

TROUBLE DIAGNOSIS — BASIC INSPECTION

Road Test (Cont'd)

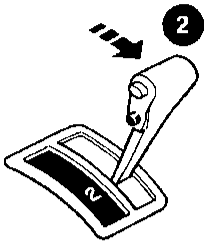
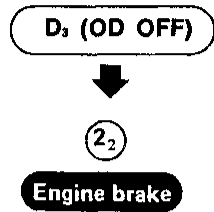
5	CHECK ENGINE BRAKE
Does vehicle decelerate by engine brake?	
	
SAT791GA	
Yes or No	
Yes	▶ GO TO 6.
No	▶ Go to "15. Engine Speed Does Not Return To Idle (Light Braking D ₄ → D ₃)", AT-207.

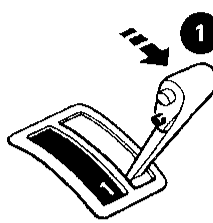
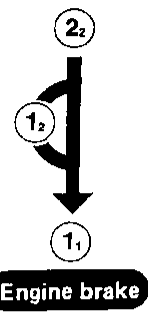
7	CHECK ENGINE BRAKE
Does vehicle decelerate by engine brake?	
	
SAT778B	
Yes or No	
Yes	▶ 1. Stop vehicle. 2. Perform self-diagnosis. Refer to SELF-DIAGNOSTIC PROCEDURE, AT-44.
No	▶ Go to "20. Vehicle Does Not Decelerate By Engine Brake", AT-211.

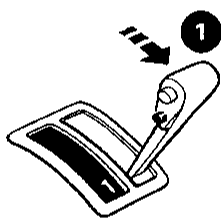
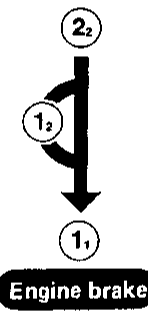
6	CHECK SHIFT DOWN (2₂ TO 1₁)
1. Move selector lever from "2" to "1" position while driving in 2 ₂ . 2. Does A/T shift from 2 ₂ to 1 ₁ position?	
	
SAT778B	
Yes or No	
Yes	▶ GO TO 7.
No	▶ Go to "19. A/T Does Not Shift: 2 ₂ → 1 ₁ , When Selector lever "2" → "1" Position", AT-211.

TROUBLE DIAGNOSIS — GENERAL DESCRIPTION

Symptom Chart

Symptom Chart

NAAT0026

Numbers are arranged in order of probability.
Perform inspections starting with number one and work up.

Symptom	Condition	Diagnostic Item	Reference Page
Engine does not start in "N", "P" positions. AT-187	ON vehicle	1. Ignition switch and starter	EL and EM section
		2. Control linkage	AT-227
		3. Inhibitor switch	AT-227
Engine starts in position other than "N" and "P" positions. AT-187	ON vehicle	1. Control linkage	AT-227
		2. Inhibitor switch	AT-227
Transmission noise in "P" and "N" positions.	ON vehicle	1. Fluid level	AT-54
		2. Line pressure	AT-57
		3. Throttle position sensor (Adjustment)	EC section
		4. Revolution sensor and vehicle speed sensor	AT-96, AT-178
		5. Engine speed signal	AT-101
	OFF vehicle	6. Oil pump	AT-246
		7. Torque converter	AT-235
Vehicle moves when changing into "P" position or parking gear does not disengage when shifted out of "P" position. AT-187	ON vehicle	1. Control linkage	AT-227
	OFF vehicle	2. Parking components	AT-286
Vehicle runs in "N" position. AT-189	ON vehicle	1. Control linkage	AT-227
		2. Accumulator 3-4 (N-R)	AT-225
	OFF vehicle	3. Forward clutch	AT-269
		4. Reverse clutch	AT-263
		5. Overrun clutch	AT-269
Vehicle will not run in "R" position (but runs in "D", "2" and "1" positions). Clutch slips. Very poor acceleration. AT-192	ON vehicle	1. Control linkage	AT-227
		2. Line pressure	AT-57
		3. Line pressure solenoid valve	AT-145
		4. Control valve assembly	AT-225
	OFF vehicle	5. Reverse clutch	AT-263
		6. High clutch	AT-267
		7. Forward clutch	AT-269
		8. Overrun clutch	AT-269
		9. Low & reverse brake	AT-273

TROUBLE DIAGNOSIS — GENERAL DESCRIPTION

Symptom Chart (Cont'd)

Symptom	Condition	Diagnostic Item	Reference Page
Vehicle braked when shifting into "R" position.	ON vehicle	1. Fluid level	AT-54
		2. Control linkage	AT-227
		3. Line pressure	AT-57
		4. Line pressure solenoid valve	AT-145
		5. Control valve assembly	AT-225
	OFF vehicle	6. High clutch	AT-267
		7. Brake band	AT-282
		8. Forward clutch	AT-269
		9. Overrun clutch	AT-269
Sharp shock in shifting from "N" to "D" position.	ON vehicle	1. Engine idling rpm	AT-57
		2. Throttle position sensor (Adjustment)	EC section
		3. Line pressure	AT-57
		4. A/T fluid temperature sensor	AT-91
		5. Engine speed signal	AT-101
		6. Line pressure solenoid valve	AT-145
		7. Control valve assembly	AT-225
		8. Accumulator N-D	AT-225
	OFF vehicle	9. Forward clutch	AT-269
Vehicle will not run in "D" and "2" positions (but runs in "1" and "R" positions).	ON vehicle	1. Control linkage	AT-227
	OFF vehicle	2. Low one-way clutch	AT-277
Vehicle will not run in "D", "1", "2" positions (but runs in "R" position). Clutch slips. Very poor acceleration. AT-194	ON vehicle	1. Fluid level	AT-54
		2. Line pressure	AT-57
		3. Line pressure solenoid valve	AT-145
		4. Control valve assembly	AT-225
		5. Accumulator N-D	AT-225
	OFF vehicle	6. Reverse clutch	AT-263
		7. High clutch	AT-267
		8. Forward clutch	AT-269
		9. Forward one-way clutch	AT-269
		10. Low one-way clutch	AT-277

TROUBLE DIAGNOSIS — GENERAL DESCRIPTION

Symptom Chart (Cont'd)

Symptom	Condition	Diagnostic Item	Reference Page	
Clutches or brakes slip somewhat in starting.	ON vehicle	1. Fluid level	AT-54	GI
		2. Control linkage	AT-227	MA
		3. Throttle position sensor (Adjustment)	EC section	EM
		4. Line pressure	AT-57	LC
		5. Line pressure solenoid valve	AT-145	EC
		6. Control valve assembly	AT-225	FE
		7. Accumulator N-D	AT-225	CL
		8. Accumulator 3-4 (N-R)	AT-225	MT
	OFF vehicle	9. Forward clutch	AT-269	AT
		10. Reverse clutch	AT-263	TF
		11. Low & reverse brake	AT-273	PD
		12. Oil pump	AT-246	AX
		13. Torque converter	AT-235	SU
Excessive creep.	ON vehicle	1. Engine idling rpm	EC section	BR
No creep at all. AT-192, AT-194	ON vehicle	1. Fluid level	AT-54	ST
		2. Line pressure	AT-57	RS
		3. Control valve assembly	AT-225	BT
	OFF vehicle	4. Forward clutch	AT-269	HA
		5. Oil pump	AT-246	SC
		6. Torque converter	AT-235	EL
Failure to change gear from "D ₁ " to "D ₂ ".	ON vehicle	1. Inhibitor switch	AT-227	IDX
		2. Control linkage	AT-227	
		3. Shift solenoid valve A	AT-151	
		4. Control valve assembly	AT-225	
		5. Revolution sensor and speed sensor	AT-96, AT-178	
	OFF vehicle	6. Brake band	AT-282	
Failure to change gear from "D ₂ " to "D ₃ ".	ON vehicle	1. Inhibitor switch	AT-227	
		2. Control linkage	AT-227	
		3. Shift solenoid valve B	AT-156	
		4. Control valve assembly	AT-225	
		5. Revolution sensor and speed sensor	AT-91, AT-178	
	OFF vehicle	6. High clutch	AT-267	
		7. Brake band	AT-282	

TROUBLE DIAGNOSIS — GENERAL DESCRIPTION

Symptom Chart (Cont'd)

Symptom	Condition	Diagnostic Item	Reference Page
Failure to change gear from "D ₃ " to "D ₄ ".	ON vehicle	1. Inhibitor switch	AT-227
		2. Control linkage	AT-227
		3. Shift solenoid valve A	AT-151
		4. Revolution sensor and speed sensor	AT-96, AT-178
		5. A/T fluid temperature sensor	AT-91
	OFF vehicle	6. Brake band	AT-282
Too high a gear change point from "D ₁ " to "D ₂ ", from "D ₂ " to "D ₃ ", from "D ₃ " to "D ₄ ". AT-198, AT-200, AT-202	ON vehicle	1. Throttle position sensor (Adjustment)	EC section
		2. Revolution sensor and speed sensor	AT-96, AT-178
		3. Shift solenoid valve A	AT-151
		4. Shift solenoid valve B	AT-156
Gear change directly from "D ₁ " to "D ₃ " occurs.	ON vehicle	1. Fluid level	AT-54
		2. Accumulator 1-2	AT-225
	OFF vehicle	3. Brake band	AT-282
Engine stops when shifting lever into "R", "D", "2" and "1".	ON vehicle	1. Engine idling rpm	AT-57
		2. Torque converter clutch solenoid valve	AT-132
		3. Control valve assembly	AT-225
	OFF vehicle	4. Torque converter	AT-235
Too sharp a shock in change from "D ₁ " to "D ₂ ".	ON vehicle	1. Throttle position sensor (Adjustment)	EC section
		2. Line pressure	AT-57
		3. Accumulator 1-2	AT-225
		4. Control valve assembly	AT-225
		5. A/T fluid temperature sensor	AT-91
	OFF vehicle	6. Brake band	AT-282
Too sharp a shock in change from "D ₂ " to "D ₃ ".	ON vehicle	1. Throttle position sensor (Adjustment)	EC section
		2. Line pressure	AT-57
		3. Accumulator 2-3	AT-225
		4. Control valve assembly	AT-225
	OFF vehicle	5. High clutch	AT-267
		6. Brake band	AT-282
Too sharp a shock in change from "D ₃ " to "D ₄ ".	ON vehicle	1. Throttle position sensor (Adjustment)	EC section
		2. Line pressure	AT-57
		3. Accumulator 3-4 (N-R)	AT-225
		4. Control valve assembly	AT-225
	OFF vehicle	5. Brake band	AT-282
		6. Overrun clutch	AT-269

TROUBLE DIAGNOSIS — GENERAL DESCRIPTION

Symptom Chart (Cont'd)

Symptom	Condition	Diagnostic Item	Reference Page	
Almost no shock or clutches slipping in change from "D ₁ " to "D ₂ ".	ON vehicle	1. Fluid level	AT-54	GI
		2. Throttle position sensor (Adjustment)	EC section	MA
		3. Line pressure	AT-57	EM
		4. Accumulator 1-2	AT-225	LC
		5. Control valve assembly	AT-225	EC
	OFF vehicle	6. Brake band	AT-282	FE
Almost no shock or slipping in change from "D ₂ " to "D ₃ ".	ON vehicle	1. Fluid level	AT-54	CL
		2. Throttle position sensor (Adjustment)	EC section	EC
		3. Line pressure	AT-57	FE
		4. Accumulator 2-3	AT-225	CL
		5. Control valve assembly	AT-225	MT
	OFF vehicle	6. High clutch	AT-267	AT
		7. Brake band	AT-282	TF
Almost no shock or slipping in change from "D ₃ " to "D ₄ ".	ON vehicle	1. Fluid level	AT-54	PD
		2. Throttle position sensor (Adjustment)	EC section	AX
		3. Line pressure	AT-57	SU
		4. Accumulator 3-4 (N-R)	AT-225	BR
		5. Control valve assembly	AT-225	ST
	OFF vehicle	6. High clutch	AT-267	RS
		7. Brake band	AT-282	BT
Vehicle braked by gear change from "D ₁ " to "D ₂ ".	ON vehicle	1. Fluid level	AT-54	HA
	OFF vehicle	2. Reverse clutch	AT-263	SC
		3. Low & reverse brake	AT-273	EL
		4. High clutch	AT-267	IDX
		5. Low one-way clutch	AT-277	
Vehicle braked by gear change from "D ₂ " to "D ₃ ".	ON vehicle	1. Fluid level	AT-54	
	OFF vehicle	2. Brake band	AT-282	
Vehicle braked by gear change from "D ₃ " to "D ₄ ".	ON vehicle	1. Fluid level	AT-54	
	OFF vehicle	2. Overrun clutch	AT-269	
		3. Forward one-way clutch	AT-269	
		4. Reverse clutch	AT-263	

TROUBLE DIAGNOSIS — GENERAL DESCRIPTION

Symptom Chart (Cont'd)

Symptom	Condition	Diagnostic Item	Reference Page
Maximum speed not attained. Acceleration poor.	ON vehicle	1. Fluid level	AT-54
		2. Inhibitor switch	AT-227
		3. Shift solenoid valve A	AT-151
		4. Shift solenoid valve B	AT-156
		5. Control valve assembly	AT-225
	OFF vehicle	6. Reverse clutch	AT-263
		7. High clutch	AT-267
		8. Brake band	AT-282
		9. Low & reverse brake	AT-273
		10. Oil pump	AT-246
		11. Torque converter	AT-235
Failure to change gear from "D ₄ " to "D ₃ ".	ON vehicle	1. Fluid level	AT-54
		2. Throttle position sensor (Adjustment)	EC section
		3. Overrun clutch solenoid valve	AT-168
		4. Shift solenoid valve A	AT-151
		5. Line pressure solenoid valve	AT-145
		6. Control valve assembly	AT-225
	OFF vehicle	7. Low & reverse brake	AT-273
		8. Overrun clutch	AT-269
Failure to change gear from "D ₃ " to "D ₂ " or from "D ₄ " to "D ₂ ".	ON vehicle	1. Fluid level	AT-54
		2. Throttle position sensor (Adjustment)	EC section
		3. Shift solenoid valve A	AT-151
		4. Shift solenoid valve B	AT-156
		5. Control valve assembly	AT-225
	OFF vehicle	6. High clutch	AT-267
		7. Brake band	AT-282
Failure to change gear from "D ₂ " to "D ₁ " or from "D ₃ " to "D ₁ ".	ON vehicle	1. Fluid level	AT-54
		2. Throttle position sensor (Adjustment)	EC section
		3. Shift solenoid valve A	AT-151
		4. Shift solenoid valve B	AT-156
		5. Control valve assembly	AT-225
	OFF vehicle	6. Low one-way clutch	AT-277
		7. High clutch	AT-267
		8. Brake band	AT-282
Gear change shock felt during deceleration by releasing accelerator pedal.	ON vehicle	1. Throttle position sensor (Adjustment)	EC section
		2. Line pressure	AT-57
		3. Overrun clutch solenoid valve	AT-168
		4. Control valve assembly	AT-225

TROUBLE DIAGNOSIS — GENERAL DESCRIPTION

Symptom Chart (Cont'd)

Symptom	Condition	Diagnostic Item	Reference Page	
Too high a change point from "D ₄ " to "D ₃ ", from "D ₃ " to "D ₂ ", from "D ₂ " to "D ₁ ".	ON vehicle	1. Throttle position sensor (Adjustment)	EC section	GI
		2. Revolution sensor and speed sensor	AT-96, AT-178	MA
Kickdown does not operate when depressing pedal in "D ₄ " within kick-down vehicle speed.	ON vehicle	1. Throttle position sensor (Adjustment)	EC section	EM
		2. Revolution sensor and speed sensor	AT-96, AT-178	LC
		3. Shift solenoid valve A	AT-151	
		4. Shift solenoid valve B	AT-156	
Kickdown operates or engine overruns when depressing pedal in "D ₄ " beyond kickdown vehicle speed limit.	ON vehicle	1. Revolution sensor and speed sensor	AT-96, AT-178	EC
		2. Throttle position sensor (Adjustment)	EC section	FE
		3. Shift solenoid valve A	AT-151	
		4. Shift solenoid valve B	AT-156	
Races extremely fast or slips in changing from "D ₄ " to "D ₃ " when depressing pedal.	ON vehicle	1. Fluid level	AT-54	CL
		2. Throttle position sensor (Adjustment)	EC section	MT
		3. Line pressure	AT-57	
		4. Line pressure solenoid valve	AT-145	
		5. Control valve assembly	AT-225	AT
	OFF vehicle	6. High clutch	AT-267	TF
		7. Forward clutch	AT-269	
Races extremely fast or slips in changing from "D ₄ " to "D ₂ " when depressing pedal.	ON vehicle	1. Fluid level	AT-54	PD
		2. Throttle position sensor (Adjustment)	EC section	AX
		3. Line pressure	AT-57	
		4. Line pressure solenoid valve	AT-145	
		5. Shift solenoid valve A	AT-151	SU
		6. Control valve assembly	AT-225	
	OFF vehicle	7. Brake band	AT-282	BR
		8. Forward clutch	AT-269	
Races extremely fast or slips in changing from "D ₃ " to "D ₂ " when depressing pedal.	ON vehicle	1. Fluid level	AT-54	ST
		2. Throttle position sensor (Adjustment)	EC section	
		3. Line pressure	AT-57	RS
		4. Line pressure solenoid valve	AT-145	
		5. Control valve assembly	AT-225	BT
		6. A/T fluid temperature sensor	AT-91	
		7. Accumulator 2-3	AT-225	HA
	OFF vehicle	8. Brake band	AT-282	
		9. Forward clutch	AT-269	SC
		10. High clutch	AT-267	EL

TROUBLE DIAGNOSIS — GENERAL DESCRIPTION

Symptom Chart (Cont'd)

Symptom	Condition	Diagnostic Item	Reference Page
Races extremely fast or slips in changing from "D ₄ " or "D ₃ " to "D ₁ " when depressing pedal.	ON vehicle	1. Fluid level	AT-54
		2. Throttle position sensor (Adjustment)	EC section
		3. Line pressure	AT-57
		4. Line pressure solenoid valve	AT-145
		5. Control valve assembly	AT-225
	OFF vehicle	6. Forward clutch	AT-269
		7. Forward one-way clutch	AT-269
		8. Low one-way clutch	AT-277
Vehicle will not run in any position.	ON vehicle	1. Fluid level	AT-54
		2. Control linkage	AT-227
		3. Line pressure	AT-57
		4. Line pressure solenoid valve	AT-145
	OFF vehicle	5. Oil pump	AT-246
		6. High clutch	AT-267
		7. Brake band	AT-282
		8. Low & reverse brake	AT-273
		9. Torque converter	AT-235
Transmission noise in "D", "2", "1" and "R" positions.	ON vehicle	1. Fluid level	AT-54
	OFF vehicle	2. Torque converter	AT-235
Failure to change from "D ₃ " to "2" when changing lever into "2" position. AT-207	ON vehicle	1. Inhibitor switch	AT-227
		2. Throttle position sensor (Adjustment)	EC section
		3. Torque converter clutch solenoid valve	AT-132
		4. Shift solenoid valve B	AT-156
		5. Shift solenoid valve A	AT-151
		6. Control valve assembly	AT-225
		7. Control linkage	AT-227
	OFF vehicle	8. Brake band	AT-282
		9. Overrun clutch	AT-269
Gear change from "2 ₂ " to "2 ₃ " in "2" position.	ON vehicle	1. Inhibitor switch	AT-227

TROUBLE DIAGNOSIS — GENERAL DESCRIPTION

Symptom Chart (Cont'd)

Symptom	Condition	Diagnostic Item	Reference Page	
Engine brake does not operate in "1" position. AT-208	ON vehicle	1. Inhibitor switch	AT-227	GI
		2. Control linkage	AT-227	MA
		3. Throttle position sensor (Adjustment)	EC section	EM
		4. Revolution sensor and speed sensor	AT-91, AT-178	LC
		5. Shift solenoid valve A	AT-151	EC
		6. Control valve assembly	AT-225	FE
		7. Overrun clutch solenoid valve	AT-168	CL
	OFF vehicle	8. Overrun clutch	AT-269	MT
		9. Low & reverse brake	AT-273	AT
Gear change from "1 ₁ " to "1 ₂ " in "1" position.	ON vehicle	1. Inhibitor switch	AT-227	TF
		2. Control linkage	AT-227	PD
Does not change from "1 ₂ " to "1 ₁ " in "1" position.	ON vehicle	1. Inhibitor switch	AT-227	AX
		2. Revolution sensor and speed sensor	AT-96, AT-178	SU
		3. Shift solenoid valve A	AT-151	BR
		4. Control valve assembly	AT-225	ST
		5. Overrun clutch solenoid valve	AT-168	RS
	OFF vehicle	6. Overrun clutch	AT-269	BT
		7. Low & reverse brake	AT-273	HA
Large shock changing from "1 ₂ " to "1 ₁ " in "1" position.	ON vehicle	1. Control valve assembly	AT-225	SC
	OFF vehicle	2. Low & reverse brake	AT-273	EL
Transmission overheats.	ON vehicle	1. Fluid level	AT-54	IDX
		2. Engine idling rpm	AT-57	
		3. Throttle position sensor (Adjustment)	EC section	
		4. Line pressure	AT-57	
		5. Line pressure solenoid valve	AT-145	
		6. Control valve assembly	AT-225	
	OFF vehicle	7. Oil pump	AT-246	
		8. Reverse clutch	AT-263	
		9. High clutch	AT-267	
		10. Brake band	AT-282	
		11. Forward clutch	AT-269	
		12. Overrun clutch	AT-269	
		13. Low & reverse brake	AT-273	
		14. Torque converter	AT-235	

TROUBLE DIAGNOSIS — GENERAL DESCRIPTION

Symptom Chart (Cont'd)

Symptom	Condition	Diagnostic Item	Reference Page
ATF shoots out during operation. White smoke emitted from exhaust pipe during operation.	ON vehicle	1. Fluid level	AT-54
	OFF vehicle	2. Reverse clutch	AT-263
		3. High clutch	AT-267
		4. Brake band	AT-282
		5. Forward clutch	AT-269
		6. Overrun clutch	AT-269
		7. Low & reverse brake	AT-273
Offensive smell at fluid charging pipe.	ON vehicle	1. Fluid level	AT-54
	OFF vehicle	2. Torque converter	AT-235
		3. Oil pump	AT-246
		4. Reverse clutch	AT-263
		5. High clutch	AT-267
		6. Brake band	AT-282
		7. Forward clutch	AT-269
		8. Overrun clutch	AT-269
		9. Low & reverse brake	AT-273
Torque converter is not locked up.	ON vehicle	1. Throttle position sensor (Adjustment)	EC section
		2. Revolution sensor and speed sensor	AT-96, AT-178
		3. Inhibitor switch	AT-227
		4. Engine speed signal	AT-101
		5. A/T fluid temperature sensor	AT-91
		6. Line pressure	AT-57
		7. Torque converter clutch solenoid valve	AT-132
		8. Control valve assembly	AT-225
	OFF vehicle	9. Torque converter	AT-235
Torque converter clutch piston slip.	ON vehicle	1. Fluid level	AT-54
		2. Line pressure	AT-57
		3. Torque converter clutch solenoid valve	AT-132
		4. Line pressure solenoid valve	AT-145
		5. Line pressure solenoid valve	AT-145
		6. Control valve assembly	AT-225
	OFF vehicle	7. Torque converter	AT-235
Lock-up point is extremely high or low. AT-204	ON vehicle	1. Throttle position sensor (Adjustment)	EC section
		2. Revolution sensor and speed sensor	AT-96, AT-178
		3. Torque converter clutch solenoid valve	AT-132
		4. Control valve assembly	AT-225

TROUBLE DIAGNOSIS — GENERAL DESCRIPTION

Symptom Chart (Cont'd)

Symptom	Condition	Diagnostic Item	Reference Page
A/T does not shift to "D ₄ " when driving with overdrive control switch "ON".	ON vehicle	1. Throttle position sensor (Adjustment)	EC section
		2. Inhibitor switch	AT-227
		3. Revolution sensor and speed sensor	AT-96, AT-178
		4. Shift solenoid valve A	AT-151
		5. Overrun clutch solenoid valve	AT-168
		6. Control valve assembly	AT-225
		7. A/T fluid temperature sensor	AT-91
		8. Line pressure	AT-57
	OFF vehicle	9. Brake band	AT-282
		10. Overrun clutch	AT-269
Engine is stopped at "R", "D", "2" and "1" positions.	ON vehicle	1. Fluid level	AT-54
		2. Torque converter clutch solenoid valve	AT-132
		3. Shift solenoid valve B	AT-156
		4. Shift solenoid valve A	AT-151
		5. Control valve assembly	AT-225

GI
 MA
 EM
 LC
 EC
 FE
 CL
 MT
AT
 TF
 PD
 AX
 SU
 BR
 ST
 RS
 BT
 HA
 SC
 EL
 DX

TROUBLE DIAGNOSIS — GENERAL DESCRIPTION

TCM Terminals and Reference Value

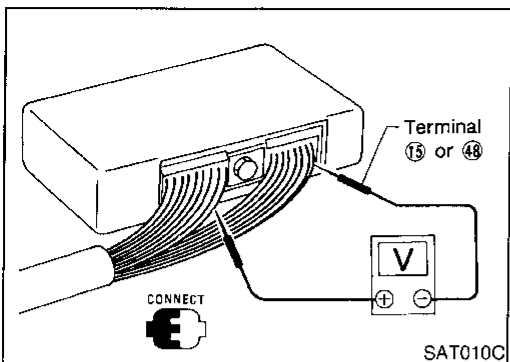

TCM Terminals and Reference Value

=NAAT0027

PREPARATION

NAAT0027S01

- Measure voltage between each terminal and terminal 15 or 48 by following "TCM INSPECTION TABLE".

TCM HARNESS CONNECTOR TERMINAL LAYOUT

NAAT0027S02

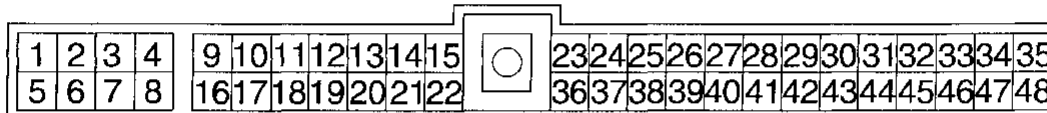

SAT2071

TCM INSPECTION TABLE

NAAT0027S03

(Data are reference values.)

Terminal No.	Wire color	Item	Condition	Judgement standard
1	GY	Line pressure solenoid valve	When releasing accelerator pedal after warming up engine.	1.5 - 2.5V
			When depressing accelerator pedal fully after warming up engine.	0.5V or less
2	BR/Y	Line pressure solenoid valve (with dropping resistor)	When releasing accelerator pedal after warming up engine.	5 - 14V
			When depressing accelerator pedal fully after warming up engine.	0.5V or less
3	GY	O/D OFF indicator lamp	When setting overdrive control switch in "OFF" position.	1V or less
			When setting overdrive control switch in "ON" position.	Battery voltage
4	W/R	Power source	When turning ignition switch to "ON".	Battery voltage
			When turning ignition switch to "OFF".	1V or less

TROUBLE DIAGNOSIS — GENERAL DESCRIPTION







TCM Terminals and Reference Value (Cont'd)

Terminal No.	Wire color	Item	Condition	Judgement standard	
5	G/OR	Torque converter clutch solenoid valve	When A/T performs lock-up.	8 - 15V	GI
			When A/T does not perform lock-up.	1V or less	MA
6	L/W	Shift solenoid valve A	When shift solenoid valve A operates. (When driving in "D ₁ " or "D ₄ ".)	Battery voltage	EM
			When shift solenoid valve A does not operate. (When driving in "D ₂ " or "D ₃ ".)	1V or less	LC
7	L/R	Shift solenoid valve B	When shift solenoid valve B operates. (When driving in "D ₁ " or "D ₂ ".)	Battery voltage	EC
			When shift solenoid valve B does not operate. (When driving in "D ₃ " or "D ₄ ".)	1V or less	FE
8	L/B	Overrun clutch solenoid valve	When overrun clutch solenoid valve operates.	Battery voltage	CL
			When overrun clutch solenoid valve does not operate.	1V or less	MT
9	W/R	Power source	Same as No. 4		AT
10*1	PU/W	DT1	—	—	TF
11*1	P/B	DT2	—	—	PD
12*1	P	DT3	—	—	AX
13	—	—	—	—	SU
14	OR/W	Closed throttle position switch (in throttle position switch)	When releasing accelerator pedal after warming up engine.	Battery voltage	BR
			When depressing accelerator pedal after warming up engine.	1V or less	ST
15	B	Ground	—	—	RS
16	G	Inhibitor "1" position switch	When setting selector lever to "1" position.	Battery voltage	BT
			When setting selector lever to other positions.	1V or less	HA
17	G/W	Inhibitor "2" position switch	When setting selector lever to "2" position.	Battery voltage	SC
			When setting selector lever to other positions.	1V or less	EL
18	L	Inhibitor "D" position switch	When setting selector lever to "D" position.	Battery voltage	SC
			When setting selector lever to other positions.	1V or less	EL
19	P	Inhibitor "N" or "P" position switch	When setting selector lever to "N" or "P" position.	Battery voltage	EL
			When setting selector lever to other positions.	1V or less	IDX



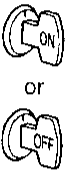



TROUBLE DIAGNOSIS — GENERAL DESCRIPTION

TCM Terminals and Reference Value (Cont'd)

Terminal No.	Wire color	Item	Condition		Judgement standard
20	Y	Inhibitor "R" position switch		When setting selector lever to "R" position.	Battery voltage
				When setting selector lever to other positions.	1V or less
21	OR/B	Wide open throttle position switch (in throttle position switch)		When depressing accelerator pedal more than half-way after warming up engine.	Battery voltage
				When releasing accelerator pedal after warming up engine.	1V or less
22	—	—	—	—	
23	R/Y	Power source (Memory back-up)		When turning ignition switch to "OFF".	Battery voltage
				When turning ignition switch to "ON".	Battery voltage
24	W/B	Engine speed signal		When engine runs at idle speed.	0.5 - 2.5V
25	W	Revolution sensor (Measure in AC range)		When vehicle cruises at 30 km/h (19 MPH).	1V or more Voltage rises gradually in response to vehicle speed.
				When vehicle parks.	0V
26	—	—	—	—	
27	W/L	Vehicle speed sensor	—	When moving vehicle at 2 to 3 km/h (1 to 2 MPH) for 1 m (3 ft) or more.	Voltage varies between less than 1V and more than 4.5V
28*2	W	—	—	—	—
29	OR	—	—	—	—
30*2	L	—	—	—	—
31	P/B	Throttle position sensor (Power source)		—	4.5 - 5.5V
				—	—
32	—	—	—	—	—
				—	—
33	R	A/T fluid temperature sensor	—	When ATF temperature is 20°C (68°F).	Approximately 1.5V
				When ATF temperature is 80°C (176°F).	Approximately 0.5V

TROUBLE DIAGNOSIS — GENERAL DESCRIPTION

TCM Terminals and Reference Value (Cont'd)

Terminal No.	Wire color	Item	Condition	Judgement standard	
34	P	Throttle position sensor		When depressing accelerator pedal slowly after warming up engine. (Voltage rises gradually in response to throttle position.)	Fully-closed throttle: Approximately 0.5V Fully-open throttle: Approximately 4V
				—	—
				—	—
35	B	Throttle position sensor (Ground)		—	
36	—	—	—	—	
37	B/Y	ASCD cruise signal		When ASCD cruise is being performed. ("CRUISE" light comes on.)	Battery voltage
				When ASCD cruise is not being performed. ("CRUISE" light does not come on.)	1V or less
38	—	—	—	—	
39	GY	Overdrive control switch		When setting overdrive control switch in "ON" position	Battery voltage
				When setting overdrive control switch in "OFF" position	1V or less
40	W/G	ASCD OD cut signal		When "ACCEL" set switch on ASCD cruise is in "D ₄ " position.	5 - 8V
				When "ACCEL" set switch on ASCD cruise is in "D ₃ " position.	1V or less
41	—	—	—	—	
42	—	—	—	—	
43	—	—	—	—	
44	—	—	—	—	
45*1	Y/G	OBD-II output		—	
46	—	—		—	
47	—	—		—	
48	B	Ground		—	

*1: These terminals are connected to the ECM.

*2: These terminals are connected to the Data link connector for CONSULT.

GI
MA
EM
LC
EC
FE
CL
MT
AT
TF
PD
AX
SU
BR
ST
RS
BT
HA
SC
EL
IDX

TROUBLE DIAGNOSIS FOR POWER SUPPLY

Wiring Diagram — AT — MAIN

Wiring Diagram — AT — MAIN

NAAT0185

AT-MAIN-01

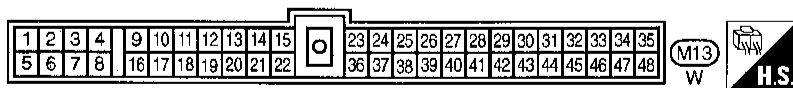
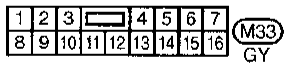
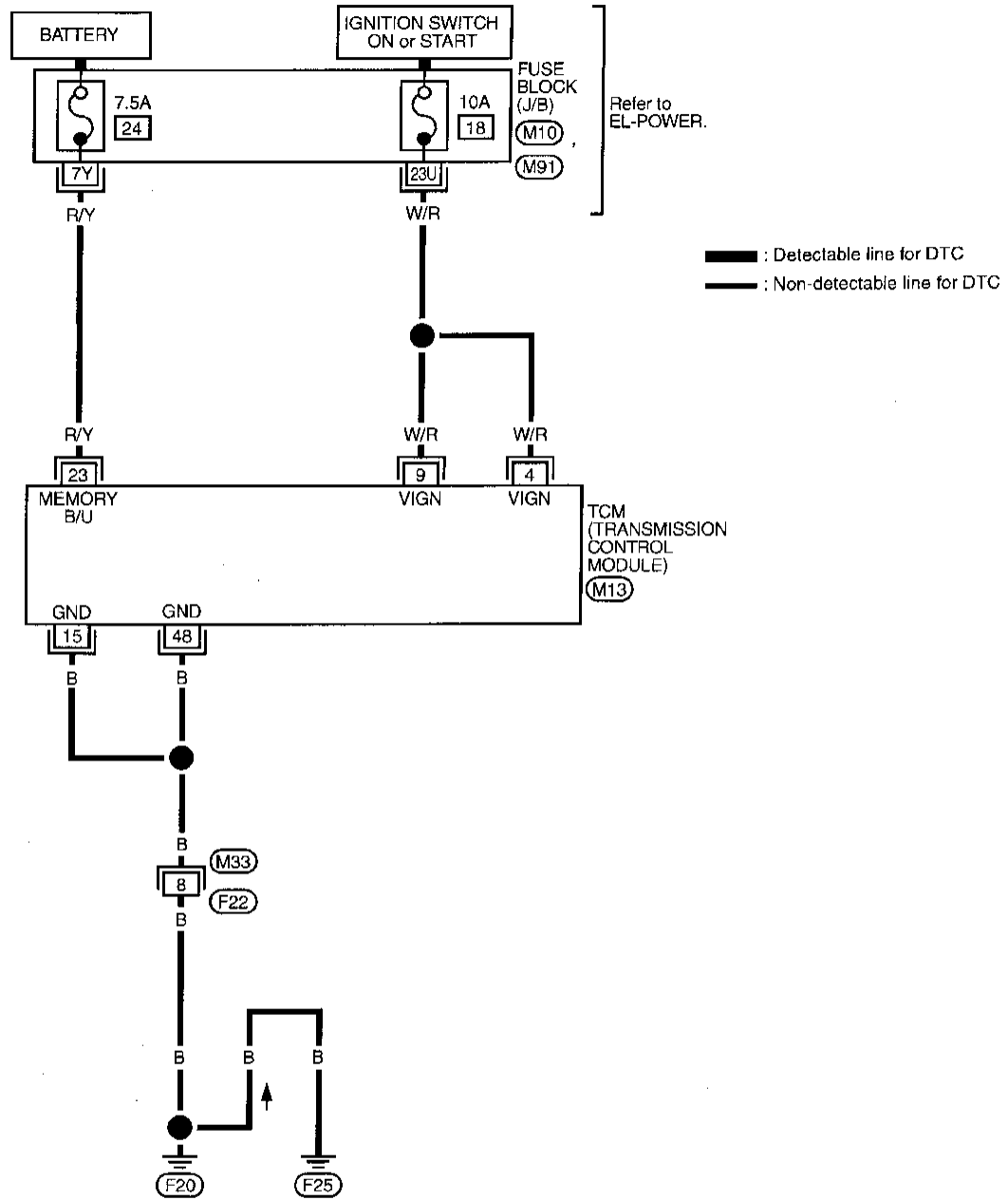

Refer to last page (Foldout page).

M10

M91





TROUBLE DIAGNOSIS FOR POWER SUPPLY

Wiring Diagram — AT — MAIN (Cont'd)

TCM TERMINALS AND REFERENCE VALUE

NAA70185S01

Remarks: Specification data are reference values.

Terminal No.	Wire color	Item	Condition	Judgement standard
4	W/R	Power source		Battery voltage
				1V or less
9	W/R	Power source		Same as No. 4
15	B	Ground	—	—
23	R/Y	Power source (Memory back-up)		Battery voltage
				Battery voltage
48	B	Ground	—	—

1 CHECK TCM POWER SOURCE

1. Turn ignition switch to "ON" position.
(Do not start engine.)

2. Check voltage between TCM terminals 4, 9, 23 and ground.

Voltage: Battery voltage

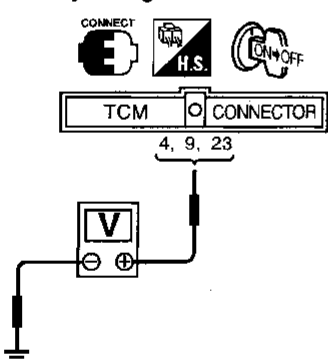

SAT909I

3. Turn ignition switch to "OFF" position.

4. Check voltage between TCM terminal 23 and ground.

Voltage: Battery voltage

OK or NG

OK	▶	GO TO 2.
NG	▶	<p>Check the following items:</p> <ul style="list-style-type: none"> • Harness for short or open between ignition switch and TCM terminals 4, 9 and 23 (Main harness) • Ignition switch and fuse Refer to EL section ("POWER SUPPLY ROUTING").

2 CHECK TCM GROUND CIRCUIT

1. Turn ignition switch to "OFF" position.

2. Disconnect TCM harness connector.

3. Check continuity between terminals 15, 48 and ground.

Continuity should exist.

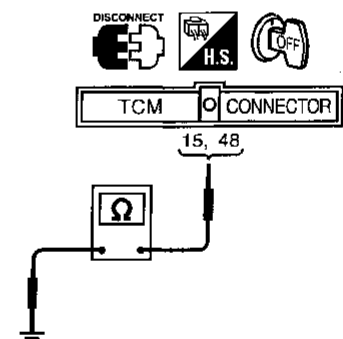

SAT910I

If OK, check harness for short to ground and short to power.

OK or NG

OK	▶	INSPECTION END
NG	▶	Repair open circuit or short to ground or short to power in harness or connectors.

DTC P0705 INHIBITOR SWITCH

Description

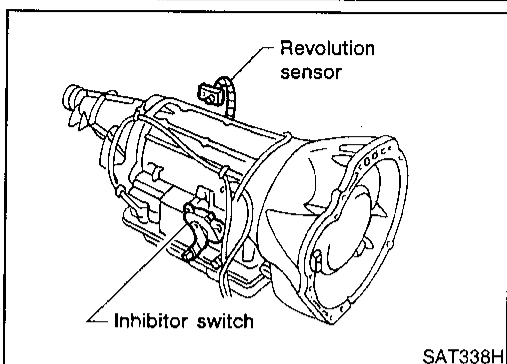

Description

NAAT0028

- Inhibitor Switch
Detects the selector lever position and sends a signal to the TCM.

TCM TERMINALS AND REFERENCE VALUE

NAAT0028S02

Remarks: Specification data are reference values.

Terminal No.	Wire color	Item	Condition	Judgement standard
16	G	Inhibitor "1" position switch	When setting selector lever to "1" position.	Battery voltage
			When setting selector lever to other positions.	1V or less
17	G/W	Inhibitor "2" position switch	When setting selector lever to "2" position.	Battery voltage
			When setting selector lever to other positions.	1V or less
18	L	Inhibitor "D" position switch	When setting selector lever to "D" position.	Battery voltage
			When setting selector lever to other positions.	1V or less
19	P	Inhibitor "N" or "P" position switch	When setting selector lever to "N" or "P" position.	Battery voltage
			When setting selector lever to other positions.	1V or less
20	Y	Inhibitor "R" position switch	When setting selector lever to "R" position.	Battery voltage
			When setting selector lever to other positions.	1V or less

ON BOARD DIAGNOSIS LOGIC

NAAT0028S03

Diagnostic trouble code	Malfunction is detected when ...	Check item (Possible cause)
(P) : INHIBITOR SW/CIRC (P0705) (MIL Code No. 1101)	TCM does not receive the correct voltage signal from the switch based on the gear position.	<ul style="list-style-type: none"> ● Harness or connectors (The inhibitor switch circuit is open or shorted.) ● Inhibitor switch

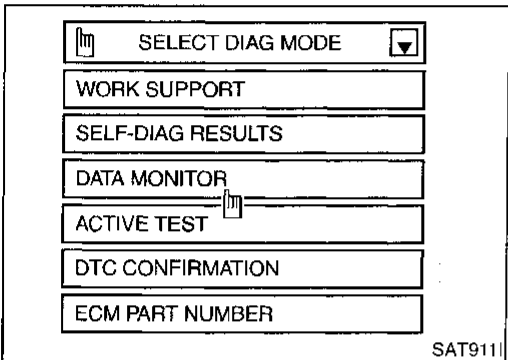
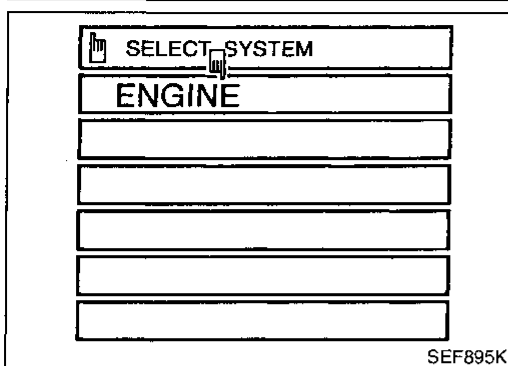

DIAGNOSTIC TROUBLE CODE (DTC) CONFIRMATION PROCEDURE

NAAT0028S01

CAUTION:

Always drive vehicle at a safe speed.

NOTE:

If "DIAGNOSTIC TROUBLE CODE CONFIRMATION PROCEDURE" has been previously conducted, always turn ignition switch "OFF" and wait at least 5 seconds before conducting the next test.

After the repair, perform the following procedure to confirm the malfunction is eliminated.

Ⓟ With CONSULT

- 1) Turn ignition switch "ON".
- 2) Select "DATA MONITOR" mode for "ENGINE" with CONSULT.
- 3) Start engine and maintain the following conditions for at least 5 consecutive seconds.

VHCL SPEED SE: 10 km/h (6 MPH) or more

THRTL POS SEN: More than 1.3V

Selector lever: D position (OD "ON" or "OFF")

Ⓢ With GST

- 1) Start engine.
- 2) Drive vehicle under the following conditions:
Selector lever in "D" position, overdrive control switch in "ON" or "OFF" position, vehicle speed higher than 10 km/h (6 MPH), throttle position sensor more than 1.3V and driving for more than 5 seconds.
- 3) Select "MODE 7" with GST.

Ⓢ No Tools

- 1) Start engine.
- 2) Drive vehicle under the following conditions:
Selector lever in "D" position, overdrive control switch in "ON" or "OFF" position, vehicle speed higher than 10 km/h (6 MPH), throttle opening greater than 1/2 of the full throttle position and driving for more than 5 seconds.
- 3) Perform self-diagnosis for ECM.
Refer to EC section ["Malfunction Indicator Lamp (MIL)", "ON BOARD DIAGNOSTIC SYSTEM DESCRIPTION"].

GI

MA

EM

LC

EC

FE

CL

MT

AT

TF

PD

AX

SU

BR

ST

RS

BT

HA

SC

EL

IDX

DTC P0705 INHIBITOR SWITCH

Wiring Diagram — AT — INH/SW

Wiring Diagram — AT — INH/SW

NAAT0186

AT-INH/SW-01

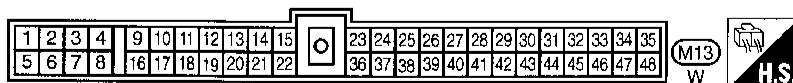
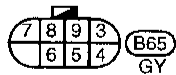
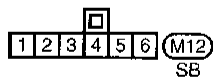
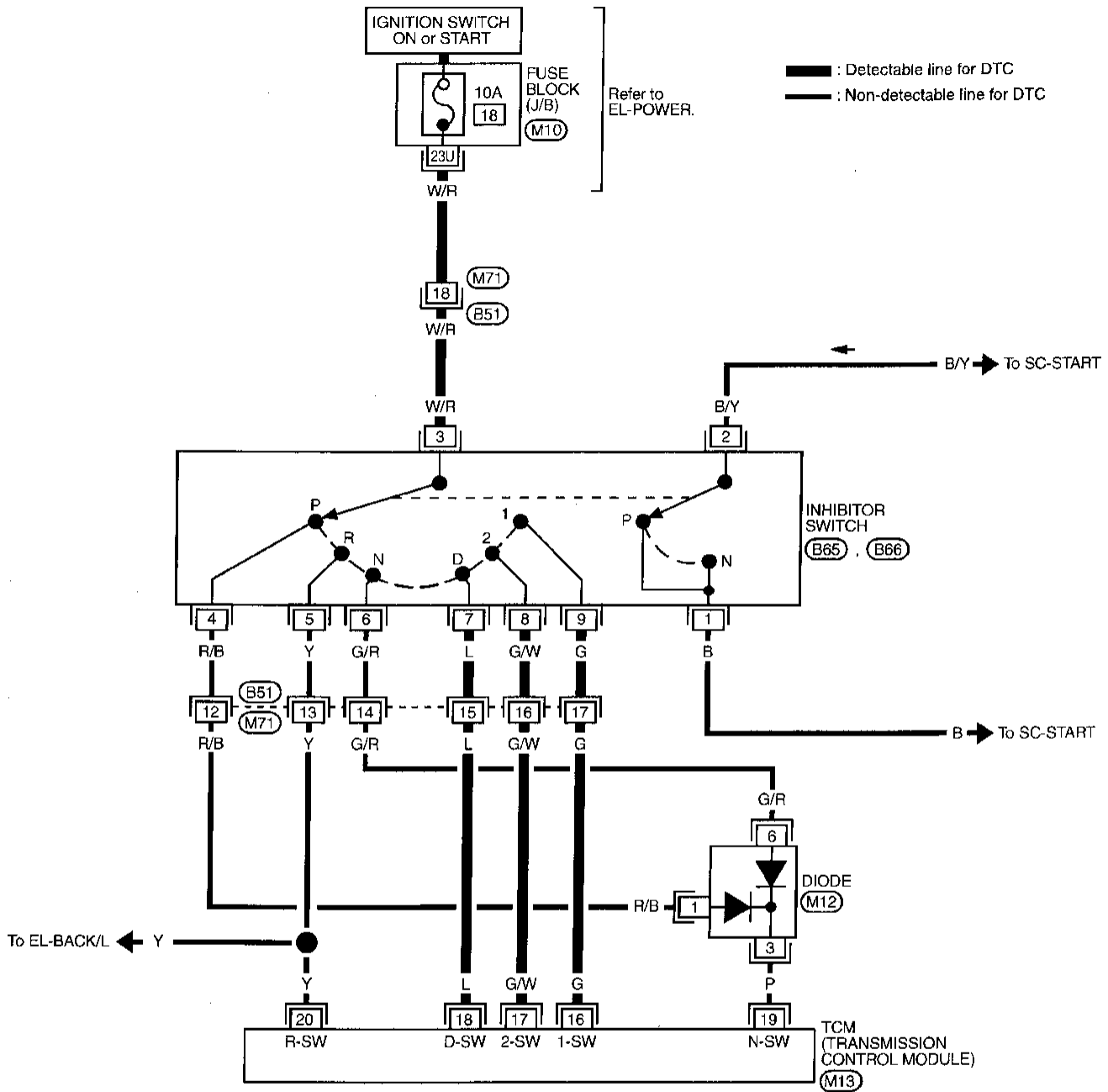

Refer to last page (Foldout page).

(M10)

Diagnostic Procedure

NAAT0029

GI
MA
EM
LC
EC
FE
CL
MT
AT
TF
PD
AX
SU
BR
ST
RS
BT
HA
SC
EL
IDX

1	CHECK INHIBITOR SWITCH CIRCUIT (With CONSULT)																														
<p>With CONSULT</p> <ol style="list-style-type: none"> Turn ignition switch to "ON" position. (Do not start engine.) Select "ECU INPUT SIGNALS" in "DATA MONITOR" mode for "A/T" with CONSULT. Read out "P", "R", "N", "D", "2" and "1" position switches moving selector lever to each position. Check the signal of the selector lever position is indicated properly. 																															
<table border="1" style="margin: auto; border-collapse: collapse;"> <tr> <td>☆ MONITOR</td> <td>☆ NO FAIL</td> <td></td> </tr> <tr> <td>R POSITION SW</td> <td>OFF</td> <td></td> </tr> <tr> <td>D POSITION SW</td> <td>OFF</td> <td></td> </tr> <tr> <td>2 POSITION SW</td> <td>OFF</td> <td></td> </tr> <tr> <td>1 POSITION SW</td> <td>OFF</td> <td></td> </tr> <tr> <td>ASCD*CRUISE</td> <td>OFF</td> <td></td> </tr> <tr> <td>ASCD*OD CUT</td> <td>OFF</td> <td></td> </tr> <tr> <td>KICKDOWN SW</td> <td>OFF</td> <td></td> </tr> <tr> <td>POWER SHIFT SW</td> <td>OFF</td> <td></td> </tr> <tr> <td>CLOSED THL/SW</td> <td>OFF</td> <td></td> </tr> </table>		☆ MONITOR	☆ NO FAIL		R POSITION SW	OFF		D POSITION SW	OFF		2 POSITION SW	OFF		1 POSITION SW	OFF		ASCD*CRUISE	OFF		ASCD*OD CUT	OFF		KICKDOWN SW	OFF		POWER SHIFT SW	OFF		CLOSED THL/SW	OFF	
☆ MONITOR	☆ NO FAIL																														
R POSITION SW	OFF																														
D POSITION SW	OFF																														
2 POSITION SW	OFF																														
1 POSITION SW	OFF																														
ASCD*CRUISE	OFF																														
ASCD*OD CUT	OFF																														
KICKDOWN SW	OFF																														
POWER SHIFT SW	OFF																														
CLOSED THL/SW	OFF																														
<table border="1" style="margin: auto; border-collapse: collapse;"> <tr> <td colspan="2" style="text-align: center;">RECORD</td> </tr> </table>		RECORD																													
RECORD																															
SAT7611																															
OK or NG																															
OK	▶ GO TO 3.																														
NG	<p>Check the following items:</p> <ul style="list-style-type: none"> Inhibitor switch Refer to "Component Inspection", AT-90. Harness for short or open between ignition switch and inhibitor switch (Main harness) Harness for short or open between inhibitor switch and TCM (Main harness) Diode (P, N positions) 																														

2	CHECK INHIBITOR SWITCH CIRCUIT (Without CONSULT)																																									
<p>Without CONSULT</p> <ol style="list-style-type: none"> Turn ignition switch to "ON" position. (Do not start engine.) Check voltage between TCM terminals 16, 17, 18, 19, 20 and ground while moving selector lever through each position. 																																										
<table border="1" style="margin: auto; border-collapse: collapse;"> <thead> <tr> <th rowspan="2">Lever position</th> <th colspan="5">Terminals</th> </tr> <tr> <th>19</th> <th>20</th> <th>18</th> <th>17</th> <th>16</th> </tr> </thead> <tbody> <tr> <td>P, N</td> <td>B</td> <td>0</td> <td>0</td> <td>0</td> <td>0</td> </tr> <tr> <td>R</td> <td>0</td> <td>B</td> <td>0</td> <td>0</td> <td>0</td> </tr> <tr> <td>D</td> <td>0</td> <td>0</td> <td>B</td> <td>0</td> <td>0</td> </tr> <tr> <td>2</td> <td>0</td> <td>0</td> <td>0</td> <td>B</td> <td>0</td> </tr> <tr> <td>1</td> <td>0</td> <td>0</td> <td>0</td> <td>0</td> <td>B</td> </tr> </tbody> </table>		Lever position	Terminals					19	20	18	17	16	P, N	B	0	0	0	0	R	0	B	0	0	0	D	0	0	B	0	0	2	0	0	0	B	0	1	0	0	0	0	B
Lever position	Terminals																																									
	19	20	18	17	16																																					
P, N	B	0	0	0	0																																					
R	0	B	0	0	0																																					
D	0	0	B	0	0																																					
2	0	0	0	B	0																																					
1	0	0	0	0	B																																					
MTBL0047																																										
SAT069J																																										
Does battery voltage exist (B) or non-existent (0)?																																										
Yes	▶ GO TO 3.																																									
No	<p>Check the following items:</p> <ul style="list-style-type: none"> Inhibitor switch Refer to "Component Inspection", AT-90. Harness for short or open between ignition switch and inhibitor switch (Main harness) Harness for short or open between inhibitor switch and TCM (Main harness) Diode (P, N positions) 																																									

3	CHECK DTC
<p>Perform Diagnostic Trouble Code (DTC) confirmation procedure, AT-87.</p>	
OK or NG	
OK	▶ INSPECTION END
NG	<ol style="list-style-type: none"> Perform TCM input/output signal inspection. If NG, recheck TCM pin terminals for damage or loose connection with harness connector.

DTC P0705 INHIBITOR SWITCH

Component Inspection

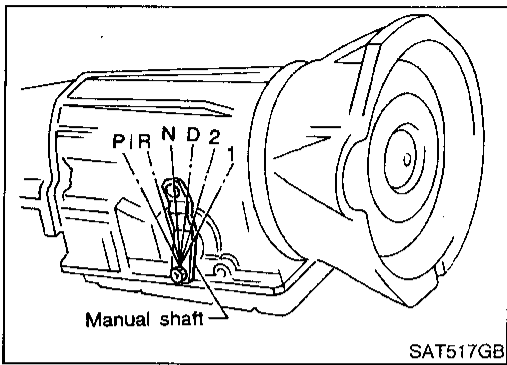

Component Inspection INHIBITOR SWITCH

NAAT0030

NAAT0030S02

1. Check continuity between terminals 1 and 2 and between terminals 3 and 4, 5, 6, 7, 8, 9 while moving manual shaft through each position.

Lever position	Terminal No.	
P	1 - 2	3 - 4
R	3 - 5	
N	1 - 2	3 - 6
D	3 - 7	
2	3 - 8	
1	3 - 9	

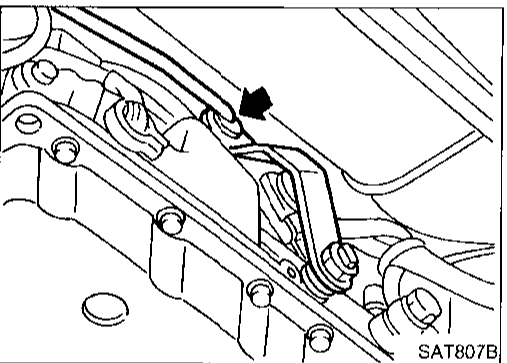
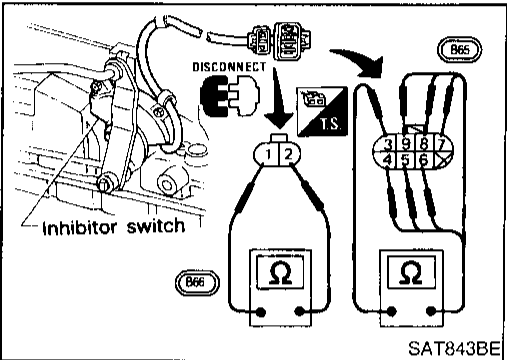

2. If NG, check again with manual control linkage disconnected from manual shaft of A/T assembly. Refer to step 1.
3. If OK on step 2, adjust manual control linkage. Refer to AT-227.

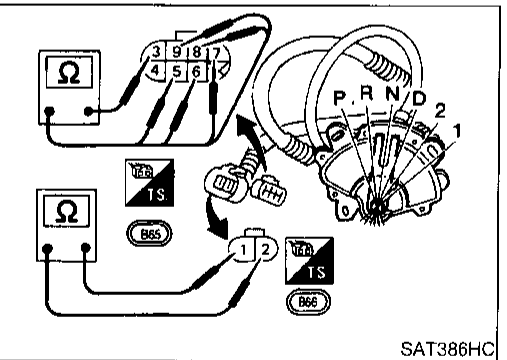

4. If NG on step 2, remove inhibitor switch from A/T and check continuity of inhibitor switch terminals. Refer to step 1.
5. If OK on step 4, adjust inhibitor switch. Refer to AT-227.
6. If NG on step 4, replace inhibitor switch.

DTC P0710 AT FLUID TEMPERATURE SENSOR CIRCUIT

Description

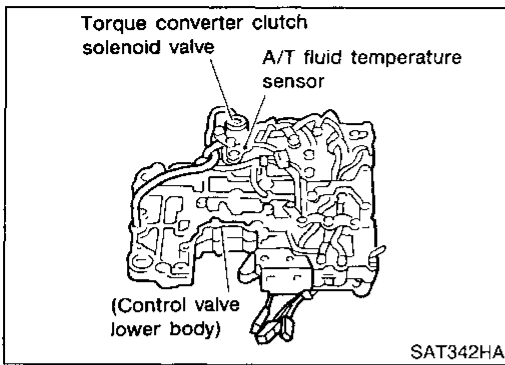

Description

The A/T fluid temperature sensor detects the A/T fluid temperature and sends a signal to the TCM. NAAT0031

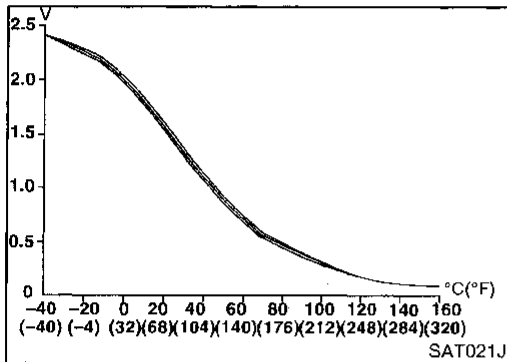

CONSULT REFERENCE VALUE IN DATA MONITOR MODE

Remarks: Specification data are reference values.

NAAT0031S04

Monitor item	Condition	Specification
A/T fluid temperature sensor	Cold [20°C (68°F)]	Approximately 1.5V
	↓	↓
	Hot [80°C (176°F)]	Approximately 0.5V

TCM TERMINALS AND REFERENCE VALUE

Remarks: Specification data are reference values.

NAAT0031S02

Terminal No.	Wire color	Item	Condition	Judgement standard
33	R	A/T fluid temperature sensor	When ATF temperature is 20°C (68°F).	Approximately 1.5V
			When ATF temperature is 80°C (176°F).	Approximately 0.5V
35	B	Throttle position sensor (Ground)	—	—

ON BOARD DIAGNOSIS LOGIC

NAAT0031S03

Diagnostic trouble code	Malfunction is detected when ...	Check item (Possible cause)
Ⓟ : ATF TEMP SEN/CIRC	TCM receives an excessively low or high voltage from the sensor.	<ul style="list-style-type: none"> • Harness or connectors (The sensor circuit is open or shorted.) • A/T fluid temperature sensor
Ⓢ : P0710		
Ⓜ : MIL Code No. 1208		

DTC P0710 A/T FLUID TEMPERATURE SENSOR CIRCUIT

Description (Cont'd)

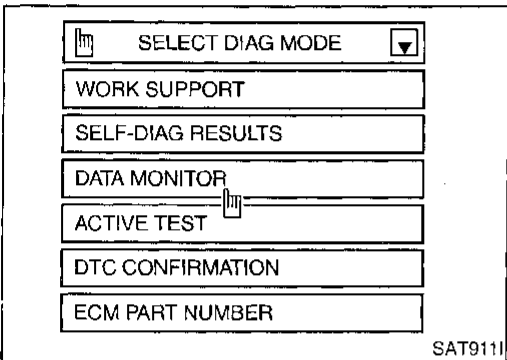
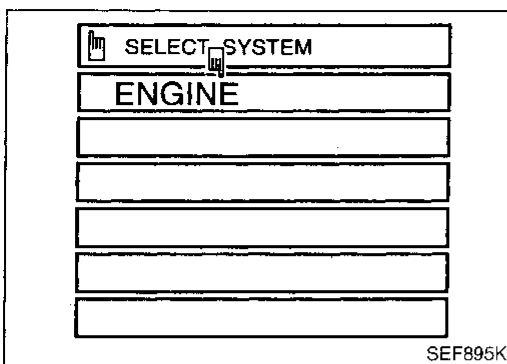

DIAGNOSTIC TROUBLE CODE (DTC) CONFIRMATION PROCEDURE

NAAT0031S01

CAUTION:

Always drive vehicle at a safe speed.

NOTE:

If "DIAGNOSTIC TROUBLE CODE CONFIRMATION PROCEDURE" has been previously conducted, always turn ignition switch "OFF" and wait at least 5 seconds before conducting the next test.

After the repair, perform the following procedure to confirm the malfunction is eliminated.

④ With CONSULT

- 1) Turn ignition switch "ON" and select "DATA MONITOR" mode for "ENGINE" with CONSULT.
- 2) Start engine and maintain the following conditions for at least 10 minutes (Total). (It is not necessary to maintain continuously.)

CMPS-RPM (REF): 450 rpm or more

VHCL SPEED SE: 10 km/h (6 MPH) or more

THRTL POS SEN: More than 1.2V

Selector lever: D position (OD "ON")

④ With GST

- 1) Start engine.
- 2) Drive vehicle under the following conditions:
Selector lever in "D" (OD "ON") position, vehicle speed higher than 10 km/h (6 MPH), throttle opening greater than 1/8 of the full open position, engine speed higher than 450 rpm and driving for more than 10 minutes (Total).
- 3) Select "MODE 7" with GST.

④ No Tools

- 1) Start engine.
- 2) Drive vehicle under the following conditions:
Selector lever in "D"(OD "ON") position, vehicle speed higher than 10 km/h (6 MPH), throttle opening greater than 1/8 of the full open position, engine speed higher than 450 rpm and driving for more than 10 minutes (Total).
- 3) Perform self-diagnosis for ECM.
Refer to EC section ["Malfunction Indicator Lamp (MIL)", "ON BOARD DIAGNOSTIC SYSTEM DESCRIPTION"].

DTC P0710 A/T FLUID TEMPERATURE SENSOR CIRCUIT

Wiring Diagram — AT — FTS

Wiring Diagram — AT — FTS

NAATO187

AT-FTS-01

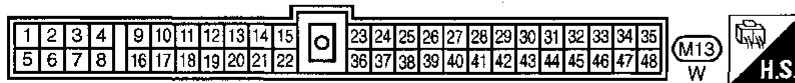
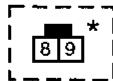
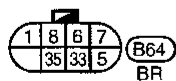
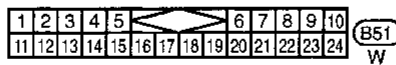
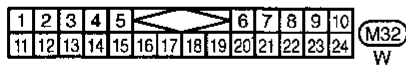
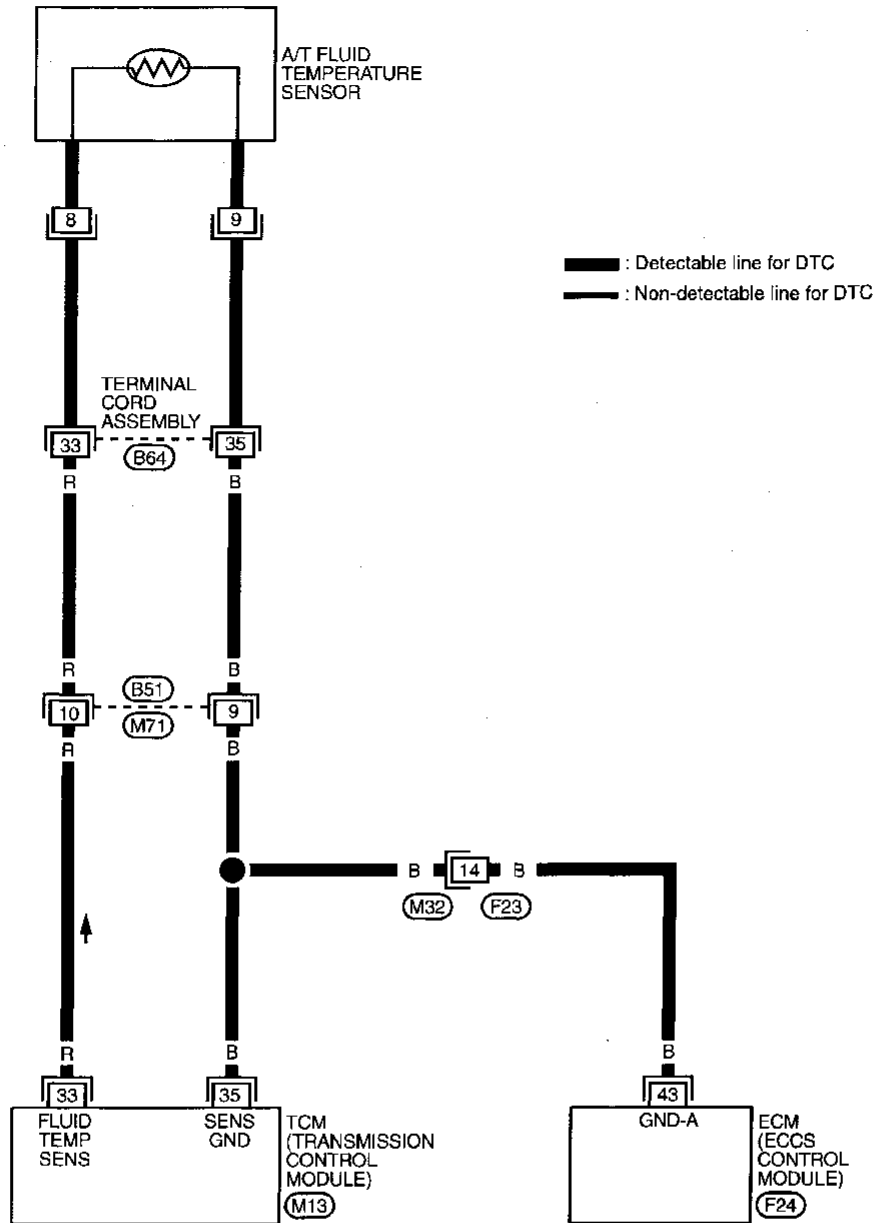

* : This connector is not shown in "HARNESS LAYOUT" in EL section.

Refer to last page (Foldout page).

(F24)

MAT555A

DTC P0710 A/T FLUID TEMPERATURE SENSOR CIRCUIT

Diagnostic Procedure

Diagnostic Procedure

NAAT0032

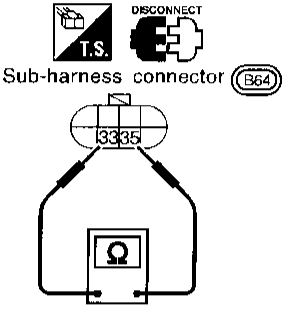
1	CHECK A/T FLUID TEMPERATURE SENSOR WITH TERMINAL CORD ASSEMBLY
<ol style="list-style-type: none"> Turn ignition switch to "OFF" position. Disconnect terminal cord assembly connector in engine compartment. Check resistance between terminals 33 and 35 when A/T is cold [20°C (68°F)]. 	
 <p>Sub-harness connector (B64)</p>	
SAT1911A	
Is resistance approx. 2.5 kΩ?	
Yes	▶ GO TO 2.
No	▶ <ol style="list-style-type: none"> Remove oil pan. Check the following items: <ul style="list-style-type: none"> A/T fluid temperature sensor Refer to "Component Inspection", AT-95. Harness of terminal cord assembly for short or open

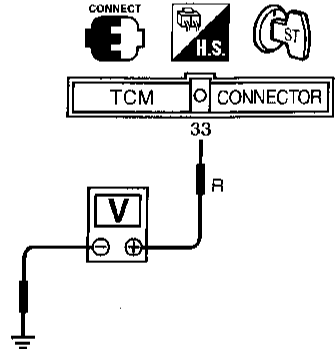
2	CHECK INPUT SIGNAL OF A/T FLUID TEMPERATURE SENSOR																														
<p>Ⓜ With CONSULT</p> <ol style="list-style-type: none"> Start engine. Select "ECU INPUT SIGNALS" in "DATA MONITOR" mode for "A/T" with CONSULT. Read out the value of "FLUID TEMP SE". <p>Voltage: Cold [20°C (68°F)] → Hot [80°C (176°F)]: Approximately 1.5V → 0.5V</p>																															
<table border="1" style="width: 100%;"> <tr> <td>☆ MONITOR</td> <td>☆ NO FAIL</td> <td><input checked="" type="checkbox"/></td> </tr> <tr> <td>VHCL/S SE-A/T</td> <td>0km/h</td> <td></td> </tr> <tr> <td>VHCL/S SE-MTR</td> <td>5km/h</td> <td></td> </tr> <tr> <td>THRTL POS SEN</td> <td>0.4V</td> <td></td> </tr> <tr> <td>FLUID TEMP SE</td> <td>1.2V</td> <td></td> </tr> <tr> <td>BATTERY VOLT</td> <td>13.4V</td> <td></td> </tr> <tr> <td>ENGINE SPEED</td> <td>1024rpm</td> <td></td> </tr> <tr> <td>OVERDRIVE SW</td> <td>O N</td> <td></td> </tr> <tr> <td>P/N POSI SW</td> <td>O N</td> <td></td> </tr> <tr> <td>R POSITION SW</td> <td>OFF</td> <td></td> </tr> </table> <p style="text-align: center; border: 1px solid black; padding: 5px;">RECORD</p>		☆ MONITOR	☆ NO FAIL	<input checked="" type="checkbox"/>	VHCL/S SE-A/T	0km/h		VHCL/S SE-MTR	5km/h		THRTL POS SEN	0.4V		FLUID TEMP SE	1.2V		BATTERY VOLT	13.4V		ENGINE SPEED	1024rpm		OVERDRIVE SW	O N		P/N POSI SW	O N		R POSITION SW	OFF	
☆ MONITOR	☆ NO FAIL	<input checked="" type="checkbox"/>																													
VHCL/S SE-A/T	0km/h																														
VHCL/S SE-MTR	5km/h																														
THRTL POS SEN	0.4V																														
FLUID TEMP SE	1.2V																														
BATTERY VOLT	13.4V																														
ENGINE SPEED	1024rpm																														
OVERDRIVE SW	O N																														
P/N POSI SW	O N																														
R POSITION SW	OFF																														
SAT076H																															
<p>ⓧ Without CONSULT</p> <ol style="list-style-type: none"> Start engine. Check voltage between TCM terminal 33 and ground while warming up A/T. <p>Voltage: Cold [20°C (68°F)] → Hot [80°C (176°F)]: Approximately 1.5V → 0.5V</p>																															
 <p>TCM CONNECTOR</p> <p>33</p> <p>V</p> <p>⊖ ⊕</p> <p>⊖ ⊕</p> <p>⊖ ⊕</p>																															
SAT9131B																															
OK or NG																															
OK	▶ GO TO 3.																														
NG	▶ <p>Check the following item:</p> <ul style="list-style-type: none"> Harness for short or open between TCM and terminal cord assembly (Main harness) 																														

DTC P0710 A/T FLUID TEMPERATURE SENSOR CIRCUIT

Diagnostic Procedure (Cont'd)

3	CHECK DTC
Perform Diagnostic Trouble Code (DTC) confirmation procedure, AT-92.	
OK or NG	
OK	▶ INSPECTION END
NG	▶ <ol style="list-style-type: none"> 1. Perform TCM input/output signal inspection. 2. If NG, recheck TCM pin terminals for damage or loose connection with harness connector.

GI
MA
EM
LC
EC
FE
CL
MT
AT
TF
PD
AX
SU
BR
ST
RS
BT
HA
SC
EL
IDX

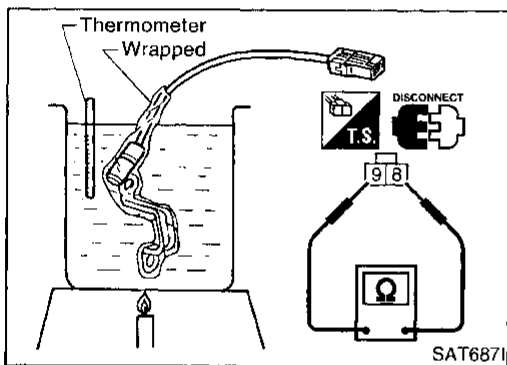

Component Inspection A/T FLUID TEMPERATURE SENSOR

NAAT0033

NAAT0033S01

- For removal, refer to AT-225.
- Check resistance between terminals 8 and 9 while changing temperature as shown at left.

Temperature °C (°F)	Resistance
20 (68)	Approximately 2.5 kΩ
80 (176)	Approximately 0.3 kΩ

DTC P0720 VEHICLE SPEED SENSOR-A/T (REVOLUTION SENSOR)

Description

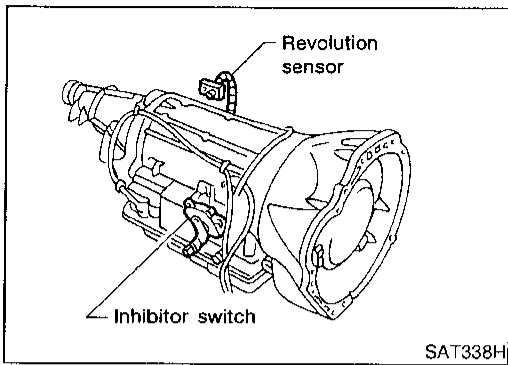



Description

The revolution sensor detects the revolution of the out put shaft parking pawl lock gear and emits a pulse signal. The pulse signal is sent to the TCM which converts it into vehicle speed. NAAT0034

TCM TERMINALS AND REFERENCE VALUE

NAAT0034S02

Remarks: Specification data are reference values.

Terminal No.	Wire color	Item	Condition	Judgement standard
25	W	Revolution sensor (Measure in AC range)	 When vehicle cruises at 30 km/h (19 MPH).	1V or more
			When vehicle parks.	0V
35	B	Throttle position sensor (Ground)		—

ON BOARD DIAGNOSIS LOGIC

NAAT0034S03

Diagnostic trouble code	Malfunction is detected when ...	Check item (Possible cause)
(P) : VEH SPD SEN/CIR AT (P0720) (MIL) : MIL Code No. 1102	TCM does not receive the proper voltage signal from the sensor.	<ul style="list-style-type: none"> • Harness or connectors (The sensor circuit is open or shorted.) • Revolution sensor

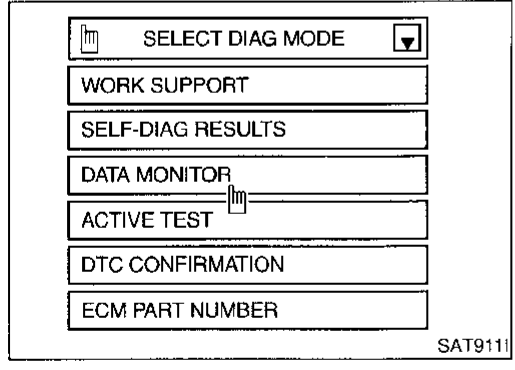
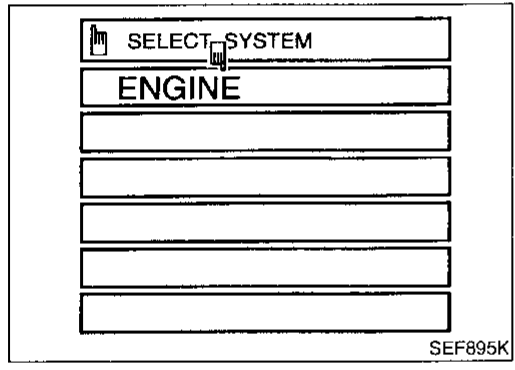
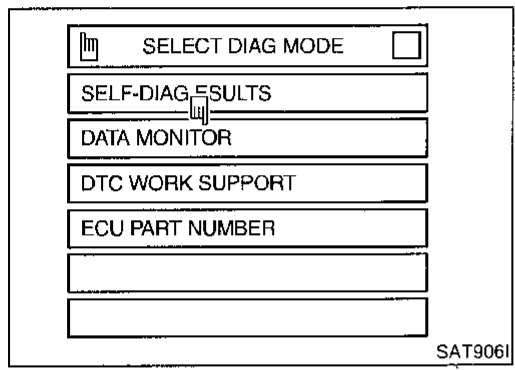
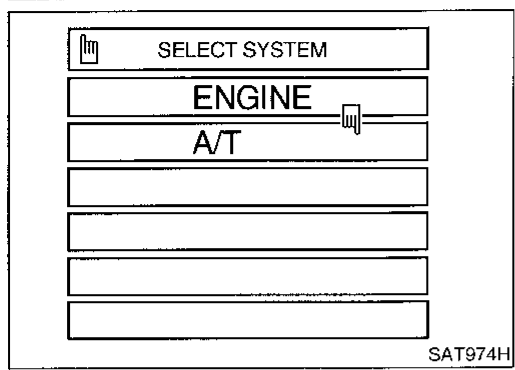

DIAGNOSTIC TROUBLE CODE (DTC) CONFIRMATION PROCEDURE

NAAT0034501

CAUTION:

- Always drive vehicle at a safe speed.
- Be careful not to rev engine into the red zone on the tachometer.

NOTE:

If "DIAGNOSTIC TROUBLE CODE CONFIRMATION PROCEDURE" has been previously conducted, always turn ignition switch "OFF" and wait at least 5 seconds before conducting the next test.

After the repair, perform the following procedure to confirm the malfunction is eliminated.

With CONSULT

- 1) Turn ignition switch "ON" and select "DATA MONITOR" mode for "A/T" with CONSULT.
- 2) Drive vehicle and check for an increase of "VHCL/S SE-A/T" value in response to "VHCL/S SE-MTR" value increase. If the check result is NG, go to "DIAGNOSTIC PROCEDURE", AT-181. If the check result is OK, go to following step.
- 3) Select "DATA MONITOR" mode for "ENGINE" with CONSULT.
- 4) Start engine and maintain the following conditions for at least 5 consecutive seconds.

VHCL SPEED SE: 30 km/h (19 MPH) or more
THRTL POS SEN: More than 1.2V
Selector lever: D position (OD "ON")

Driving pattern: Driving the vehicle uphill (increased engine load) will help maintain the driving conditions required for this test.

If the check result is NG, go to "DIAGNOSTIC PROCEDURE", AT-99.

If the check result is OK, go to following step.

- 5) Maintain the following conditions for at least 5 consecutive seconds.

CMPS-RPM (REF): 3,500 rpm or more
THRTL POS SEN: More than 1.2V
Selector lever: D position (OD "ON")

Driving pattern: Driving the vehicle uphill (increased engine load) will help maintain the driving conditions required for this test.

With GST

- 1) Start engine.
- 2) Drive vehicle under the following conditions:
Selector lever in "D" (OD "ON") position, vehicle speed higher than 30 km/h (19 MPH), throttle opening greater than 1/8 of the full throttle position and driving for more than 5 seconds.
- 3) Select "MODE 7" with GST.

No Tools

- 1) Start engine.
- 2) Drive vehicle under the following conditions:
Selector lever in "D" (OD "ON") position, vehicle speed higher than 30 km/h (19 MPH), throttle opening greater than 1/8 of the full throttle position and driving for more than 5 seconds.
- 3) Perform self-diagnosis for ECM.
Refer to EC section ["Malfunction Indicator Lamp (MIL)", "ON BOARD DIAGNOSTIC SYSTEM DESCRIPTION"].

GI
MA
EM
LC
EC
FE
CL
MT
AT
TF
PD
AX
SU
BR
ST
RS
BT
HA
SC
EL
DX

DTC P0720 VEHICLE SPEED SENSOR A/T (REVOLUTION SENSOR)

Wiring Diagram — AT — VSSA/T

Wiring Diagram — AT — VSSA/T

NAAT0198

AT-VSSAT-01

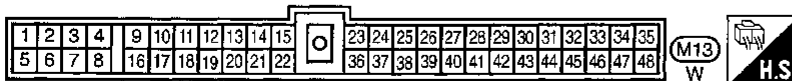
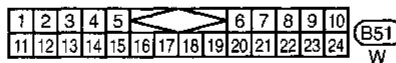
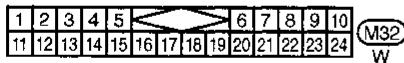
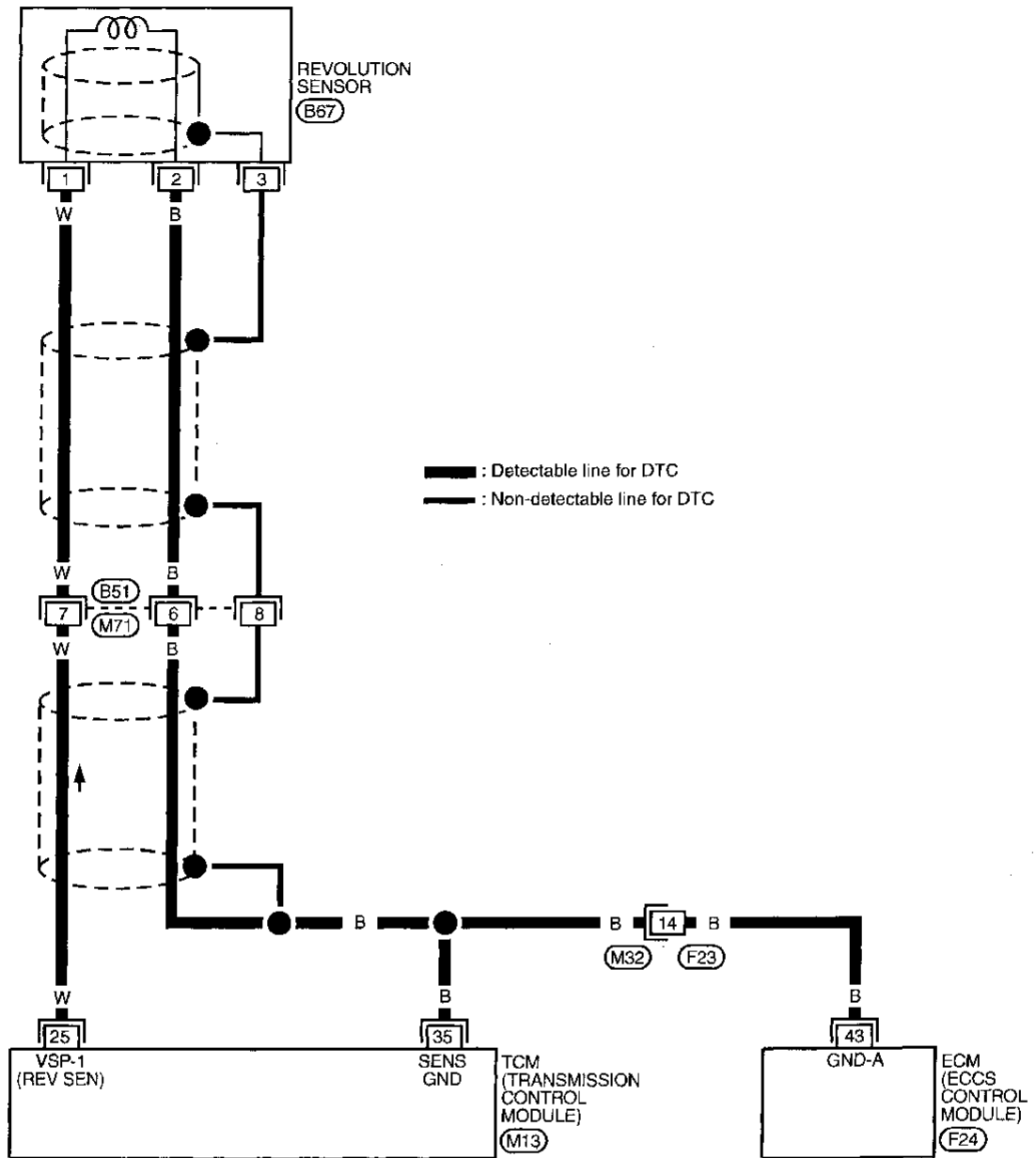

Refer to last page (Foldout page).

(F24)

Diagnostic Procedure

NAAT0095

GI
MA
EM
LC
EC
FE
CL
MT
AT
TF
PD
AX
SU
BR
ST
RS
BT
HA
SC
EL
IDX

1	CHECK REVOLUTION SENSOR
Refer to "Component Inspection", AT-100.	
OK or NG	
OK	▶ GO TO 2.
NG	▶ Repair or replace revolution sensor.

2 CHECK INPUT SIGNAL

With CONSULT

1. Start engine.
2. Select "ECU INPUT SIGNALS" in "DATA MONITOR" mode for "A/T" with CONSULT.
3. Read out the value of "VHCL/S SE-A/T" while driving. Check the value changes according to driving speed.

☆ MONITOR	☆ NO FAIL	<input checked="" type="checkbox"/>
VHCL/S SE-A/T	0km/h	
VHCL/S SE-MTR	5km/h	
THRTL POS SEN	0.4V	
FLUID TEMP SE	1.2V	
BATTERY VOLT	13.4V	
ENGINE SPEED	1024rpm	
OVERDRIVE SW	O N	
P/N POSI SW	O N	
R POSITION SW	OFF	

RECORD

SAT076H

Without CONSULT

1. Start engine.
2. Check voltage between TCM terminal 25 and ground while driving.

(Measure with AC range.)

Voltage:

At 0 km/h (0 MPH):

0V

At 30 km/h (19 MPH):

1V or more

(Voltage rises gradually in response to vehicle speed.)

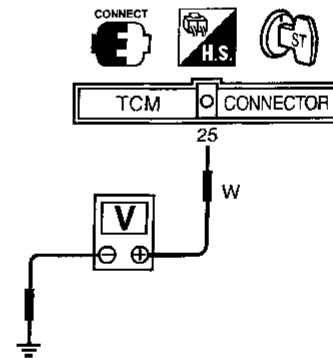

SAT919IB

OK or NG

OK	▶ GO TO 3.
NG	▶ Check the following items: <ul style="list-style-type: none"> • Harness for short or open between TCM and revolution sensor (Main harness) • Harness for short or open between revolution sensor and ECM (Main harness) • Ground circuit for ECM Refer to EC section ("TROUBLE DIAGNOSIS FOR POWER SUPPLY").

DTC P0720 VEHICLE SPEED SENSOR-A/T (REVOLUTION SENSOR)

Diagnostic Procedure (Cont'd)

3	CHECK DTC	
Perform Diagnostic Trouble Code (DTC) confirmation procedure, AT-97.		
OK or NG		
OK	▶	INSPECTION END
NG	▶	<ol style="list-style-type: none"> 1. Perform TCM input/output signal inspection. 2. If NG, recheck TCM pin terminals for damage or loose connection with harness connector.

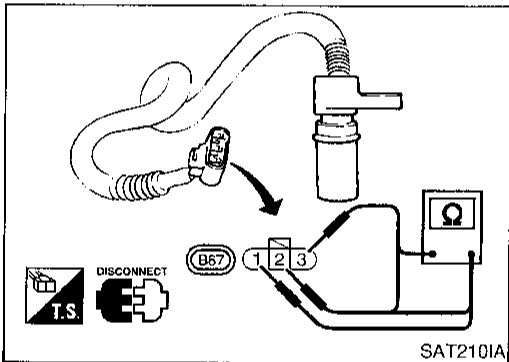

Component Inspection REVOLUTION SENSOR

NAAT0096

NAAT0036S01

- For removal, refer to AT-225.
- Check resistance between terminals 1, 2 and 3.

Terminal No.		Resistance
1	2	500 - 650Ω
2	3	No continuity
1	3	No continuity

DTC P0725 ENGINE SPEED SIGNAL

Description

Description

The engine speed signal is sent from the ECM to the TCM. NAAT0037

TCM TERMINALS AND REFERENCE VALUE

NAAT0037S02

Remarks: Specification data are reference values.

Terminal No.	Wire color	Item	Condition	Judgement standard
24	W/B	Engine speed signal	 When engine runs at idle speed.	0.5 - 2.5V

ON BOARD DIAGNOSIS LOGIC

NAAT0037S03

Diagnostic trouble code	Malfunction is detected when ...	Check item (Possible cause)
(P) : ENGINE SPEED SIG (P0725) (MIL) : MIL Code No. 1207	TCM does not receive the proper voltage signal from ECM.	<ul style="list-style-type: none"> Harness or connectors (The sensor circuit is open or shorted.)

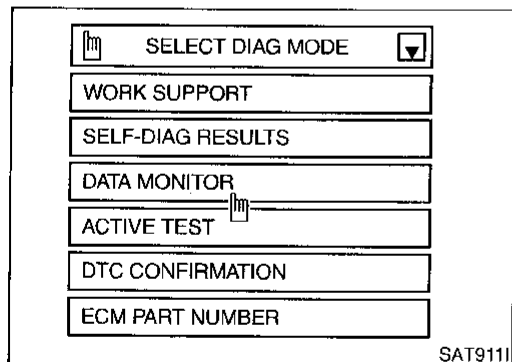
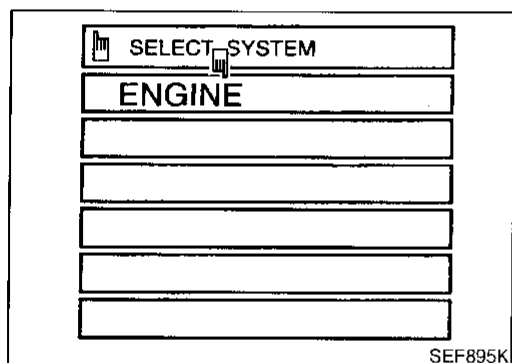

DIAGNOSTIC TROUBLE CODE (DTC) CONFIRMATION PROCEDURE

NAAT0037S01

CAUTION:

Always drive vehicle at a safe speed.

NOTE:

If "DIAGNOSTIC TROUBLE CODE CONFIRMATION PROCEDURE" has been previously conducted, always turn ignition switch "OFF" and wait at least 5 seconds before conducting the next test.

After the repair, perform the following procedure to confirm the malfunction is eliminated.

(P) With CONSULT

- 1) Turn ignition switch "ON" and select "DATA MONITOR" mode for "ENGINE" with CONSULT.
- 2) Start engine and maintain the following conditions for at least 10 consecutive seconds.
VHCL SPEED SE: 10 km/h (6 MPH) or more
THRTL POS SEN: More than 1.2V
Selector lever: D position (OD "ON")

(GST) With GST

- 1) Start engine.
- 2) Drive vehicle under the following conditions:
 Selector lever in "D" (OD "ON") position, vehicle speed higher than 10 km/h (6 MPH), throttle opening greater than 1/8 of the full throttle position and driving for more than 10 seconds.
- 3) Select "MODE 7" with GST.

(TDS) No Tools

- 1) Start engine.
- 2) Drive vehicle under the following conditions:
 Selector lever in "D" (OD "ON") position, vehicle speed higher than 10 km/h (6 MPH), throttle opening greater than 1/8 of the full throttle position and driving for more than 10 consecutive seconds.

DTC P0725 ENGINE SPEED SIGNAL

Description (Cont'd)

- 3) Perform self-diagnosis for ECM.
Refer to EC section ["Malfunction Indicator Lamp (MIL)", "ON BOARD DIAGNOSTIC SYSTEM DESCRIPTION"].

DTC P0725 ENGINE SPEED SIGNAL

Wiring Diagram — AT — ENGSS

Wiring Diagram — AT — ENGSS

NAAT0189

AT-ENGSS-01

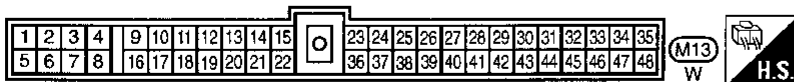
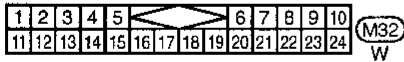
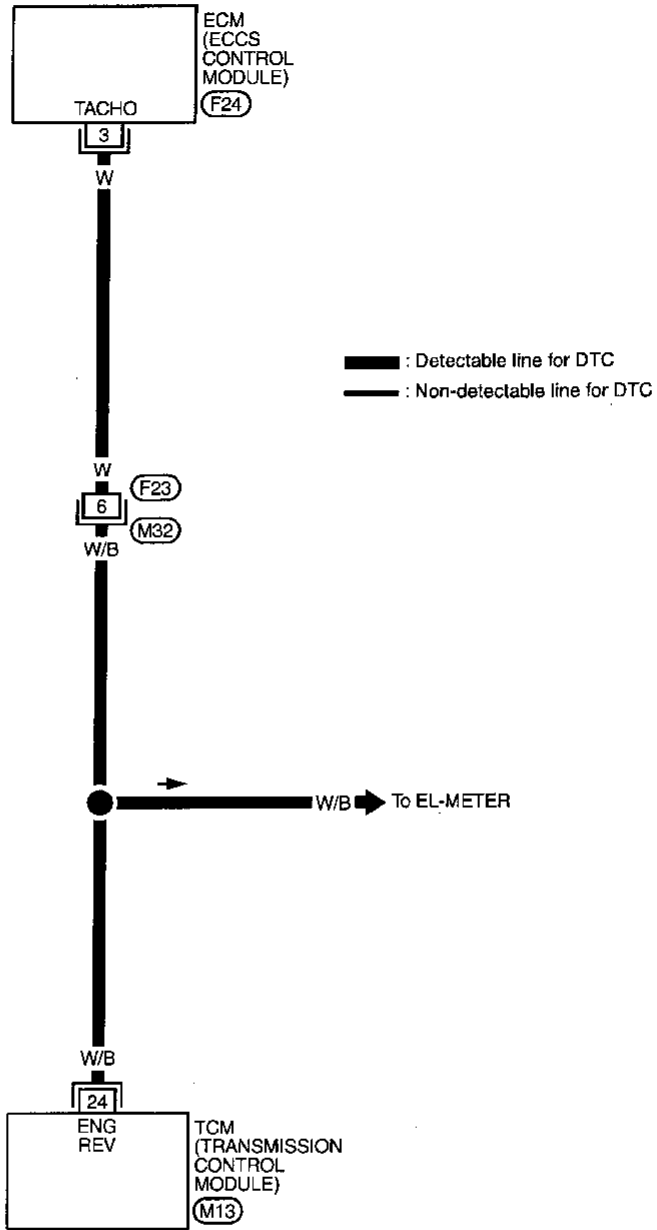

Refer to last page (Foldout page).

(F24)

MAT557A

GI
 MA
 EM
 LC
 EC
 FE
 CL
 MT
AT
 TF
 PD
 AX
 SU
 BR
 ST
 RS
 BT
 HA
 SC
 EL
 IDX

DTC P0725 ENGINE SPEED SIGNAL

Diagnostic Procedure

Diagnostic Procedure

NAAT0038

1	CHECK DTC WITH ECM
Perform diagnostic test mode II (self-diagnostic results) for engine control. Check ignition signal circuit condition.	
OK or NG	
OK	▶ GO TO 2.
NG	▶ Check ignition signal circuit for engine control. Refer to EC section ("DTC P1320 IGNITION SIGNAL").

3	CHECK DTC
Perform Diagnostic Trouble Code (DTC) confirmation procedure, AT-101.	
OK or NG	
OK	▶ INSPECTION END
NG	▶ <ol style="list-style-type: none"> 1. Perform TCM input/output signal inspection. 2. If NG, recheck TCM pin terminals for damage or loose connection with harness connector.

2	CHECK INPUT SIGNAL																						
<p>Ⓜ With CONSULT</p> <ol style="list-style-type: none"> 1. Start engine. 2. Select "ECU INPUT SIGNALS" in "DATA MONITOR" mode for "A/T" with CONSULT. 3. Read out the value of "ENGINE SPEED". Check engine speed changes according to throttle position. 																							
<table border="1" style="width: 100%;"> <tr> <td>☆MONITOR ☆NO FAIL</td> <td style="text-align: right;">▼</td> </tr> <tr> <td>VHCL/S SE•A/T</td> <td style="text-align: right;">0km/h</td> </tr> <tr> <td>VHCL/S SE•MTR</td> <td style="text-align: right;">5km/h</td> </tr> <tr> <td>THRTL POS SEN</td> <td style="text-align: right;">0.4V</td> </tr> <tr> <td>FLUID TEMP SE</td> <td style="text-align: right;">1.2V</td> </tr> <tr> <td>BATTERY VOLT</td> <td style="text-align: right;">13.4V</td> </tr> <tr> <td>ENGINE SPEED</td> <td style="text-align: right;">1024rpm</td> </tr> <tr> <td>OVERDRIVE SW</td> <td style="text-align: right;">O N</td> </tr> <tr> <td>P/N POSI SW</td> <td style="text-align: right;">O N</td> </tr> <tr> <td>R POSITION SW</td> <td style="text-align: right;">OFF</td> </tr> <tr> <td colspan="2" style="text-align: center; border: 1px solid black; padding: 5px;">RECORD</td> </tr> </table>		☆MONITOR ☆NO FAIL	▼	VHCL/S SE•A/T	0km/h	VHCL/S SE•MTR	5km/h	THRTL POS SEN	0.4V	FLUID TEMP SE	1.2V	BATTERY VOLT	13.4V	ENGINE SPEED	1024rpm	OVERDRIVE SW	O N	P/N POSI SW	O N	R POSITION SW	OFF	RECORD	
☆MONITOR ☆NO FAIL	▼																						
VHCL/S SE•A/T	0km/h																						
VHCL/S SE•MTR	5km/h																						
THRTL POS SEN	0.4V																						
FLUID TEMP SE	1.2V																						
BATTERY VOLT	13.4V																						
ENGINE SPEED	1024rpm																						
OVERDRIVE SW	O N																						
P/N POSI SW	O N																						
R POSITION SW	OFF																						
RECORD																							
SAT076H																							

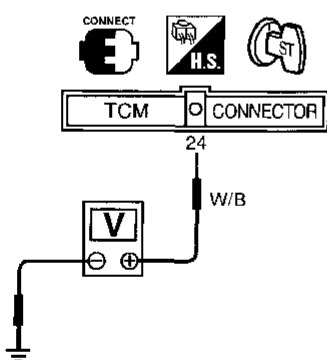
<p>ⓧ Without CONSULT</p> <ol style="list-style-type: none"> 1. Start engine. 2. Check voltage between TCM terminal 24 and ground. 	
	
SAT923IB	
Does battery voltage (idle speed) 0.5 - 2.5V?	
Yes	▶ GO TO 3.
No	▶ <p>Check the following items:</p> <ul style="list-style-type: none"> ● Harness for short or open between TCM and ECM ● Resistor ● Ignition coil <p>Refer to EC section ("DTC P1320 IGNITION SIGNAL").</p>

DTC P0731 IMPROPER SHIFTING TO 1ST GEAR POSITION

Description

Description

- This is an OBD-II self-diagnostic item and not available in TCM self-diagnosis.
- This malfunction will not be detected while the O/D OFF indicator lamp is indicating another self-diagnosis malfunction.
- This malfunction is detected when the A/T does not shift into first gear position as instructed by the TCM. This is not caused by electrical malfunction (circuits open or shorted) but by mechanical malfunction such as control valve sticking, improper solenoid valve operation, etc.

Gear position	1	2	3	4
Shift solenoid valve A	ON (Closed)	OFF (Open)	OFF (Open)	ON (Closed)
Shift solenoid valve B	ON (Closed)	ON (Closed)	OFF (Open)	OFF (Open)

TCM TERMINALS AND REFERENCE VALUE

Remarks: Specification data are reference values.

Terminal No.	Wire color	Item	Condition	Judgement standard
6	L/W	Shift solenoid valve A	When shift solenoid valve A operates. (When driving in "D ₁ " or "D ₄ ".)	Battery voltage
			When shift solenoid valve A does not operate. (When driving in "D ₂ " or "D ₃ ".)	1V or less
7	L/R	Shift solenoid valve B	When shift solenoid valve B operates. (When driving in "D ₁ " or "D ₂ ".)	Battery voltage
			When shift solenoid valve B does not operate. (When driving in "D ₃ " or "D ₄ ".)	1V or less



ON BOARD DIAGNOSIS LOGIC

This diagnosis monitors actual gear position by checking the torque converter slip ratio calculated by TCM as follows:

$$\text{Torque converter slip ratio} = A \times C/B$$

A: Output shaft revolution signal from revolution sensor

B: Engine speed signal from ECM

C: Gear ratio determined as gear position which TCM supposes

If the actual gear position is higher than the position (1st) supposed by TCM, the slip ratio will be more than normal. In case the ratio exceeds the specified value, TCM judges this diagnosis malfunction.

This malfunction will be caused when either shift solenoid valve A is stuck open or shift solenoid valve B is stuck open.

Gear position supposed by TCM	1	2	3	4
In case of gear position with no malfunctions	1	2	3	4
In case of gear position with shift solenoid valve A stuck open	2*	2	3	3
In case of gear position with shift solenoid valve B stuck open	4*	3	3	4

*: P0731 is detected.

DTC P0731 IMPROPER SHIFTING TO 1ST GEAR POSITION

Description (Cont'd)

Diagnostic trouble code	Malfunction is detected when ...	Check item (Possible cause)
: A/T 1ST GR FNCTN	A/T cannot be shifted to the 1st gear position even if electrical circuit is good.	<ul style="list-style-type: none"> • Shift solenoid valve A • Shift solenoid valve B • Each clutch • Hydraulic control circuit
: P0731		
: MIL Code No. 1103		

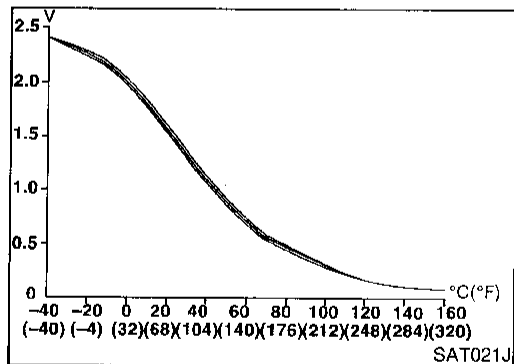
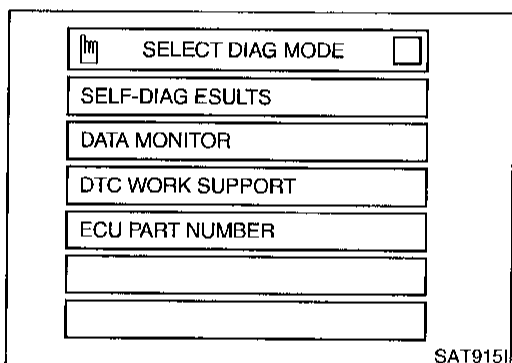
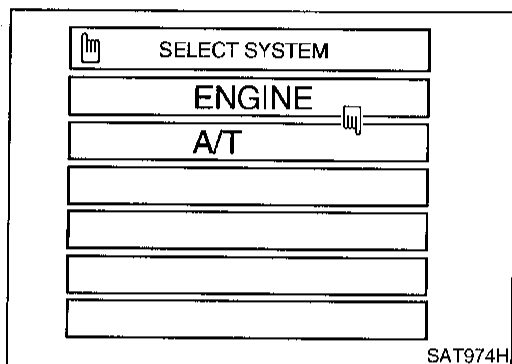

DIAGNOSTIC TROUBLE CODE (DTC) CONFIRMATION PROCEDURE

NAAT0039501

CAUTION:

- Always drive vehicle at a safe speed.
- Be careful not to rev engine into the red zone on the tachometer.

NOTE:

If "DIAGNOSTIC TROUBLE CODE CONFIRMATION PROCEDURE" has been previously conducted, always turn ignition switch "OFF" and wait at least 5 seconds before conducting the next test.

TESTING CONDITIONS:

Always drive vehicle on a level road to improve the accuracy of test.

After the repair, perform the following procedure to confirm the malfunction is eliminated.

With CONSULT

- 1) Start engine and select "DATA MONITOR" mode for "A/T" with CONSULT.
- 2) Make sure that output voltage of A/T fluid temperature sensor is within the range below.
FLUID TEMP SEN: 0.4 - 1.5V
If out of range, drive the vehicle to decrease the voltage (warm up the fluid) or stop engine to increase the voltage (cool down the fluid).
- 3) Select "1ST GR FNCTN P0731" of "DTC WORK SUPPORT" mode for "A/T" with CONSULT and touch "START".
- 4) Accelerate vehicle to 20 to 25 km/h (12 to 16 MPH) under the following condition and release the accelerator pedal completely.

THROTTLE POSI: Less than 1/8 (at all times during step 4)
Selector lever: D position (OD "ON")

- Check that "GEAR" shows "2" after releasing pedal.
- 5) Depress accelerator pedal to WOT (more than 7/8 of "THROTTLE POSI") quickly from a speed of 20 to 25 km/h (12 to 16 MPH) until "TESTING" changes to "STOP VEHICLE" or "COMPLETED". (It will take approximately 3 seconds.)
If the check result NG appears on CONSULT screen, go to "DIAGNOSTIC PROCEDURE", AT-109.
If "STOP VEHICLE" appears on CONSULT screen, go to the following step.
- Check that "GEAR" shows "1" when depressing accelerator pedal to WOT.
 - If "TESTING" does not appear on CONSULT for a long time, select "SELF-DIAG RESULTS" for "ENGINE". In case

DTC P0731 IMPROPER SHIFTING TO 1ST GEAR POSITION

Description (Cont'd)

a 1st trip DTC other than P0731 is shown, refer to applicable "TROUBLE DIAGNOSIS FOR DTC".

- 6) Stop vehicle.
- 7) Follow the instruction displayed. (Check for normal shifting referring to the table below.)

Vehicle condition	Gear on actual transmission shift pattern when screen is changed to 1 → 2 → 3 → 4
No malfunction exists	1 → 2 → 3 → 4
Malfunction for P0731 exists.	2 → 2 → 3 → 3
	4 → 3 → 3 → 4

- 8) Make sure that "OK" is displayed. (If "NG" is displayed, refer to "DIAGNOSTIC PROCEDURE".)
Refer to "DIAGNOSTIC PROCEDURE", AT-109.
Refer to shift schedule, AT-307.

With GST

- 1) Start engine and warm up ATF.
- 2) Accelerate vehicle to 20 to 25 km/h (12 to 16 MPH) under the following condition and release the accelerator pedal completely.

THROTTLE POSI: Less than 1/8

Selector lever: D position (OD "ON")

Refer to shift schedule, AT-307.

- 3) Depress accelerator pedal to WOT (more than 7/8 of "THROTTLE POSI") quickly from a speed of 20 to 25 km/h (12 to 16 MPH). (It will take approximately 3 seconds.)
- 4) Select "MODE 7" with GST.

No Tools

- 1) Start engine and warm up ATF.
- 2) Accelerate vehicle to 20 to 25 km/h (12 to 16 MPH) under the following condition and release the accelerator pedal completely.

THROTTLE POSI: Less than 1/8

Selector lever: D position (OD "ON")

Refer to shift schedule, AT-307.

- 3) Depress accelerator pedal to WOT (more than 7/8 of "THROTTLE POSI") quickly from a speed of 20 to 25 km/h (12 to 16 MPH). (It will take approximately 3 seconds.)

- 4) Perform self-diagnosis for ECM.
Refer to EC section ["Malfunction Indicator Lamp (MIL)", "ON BOARD DIAGNOSTIC SYSTEM DESCRIPTION"].

DTC P0731 IMPROPER SHIFTING TO 1ST GEAR POSITION

Wiring Diagram — AT — 1ST

Wiring Diagram — AT — 1ST

NAAT0190

AT-1STSIG-01

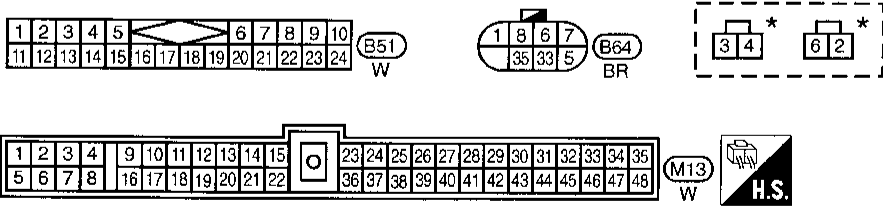
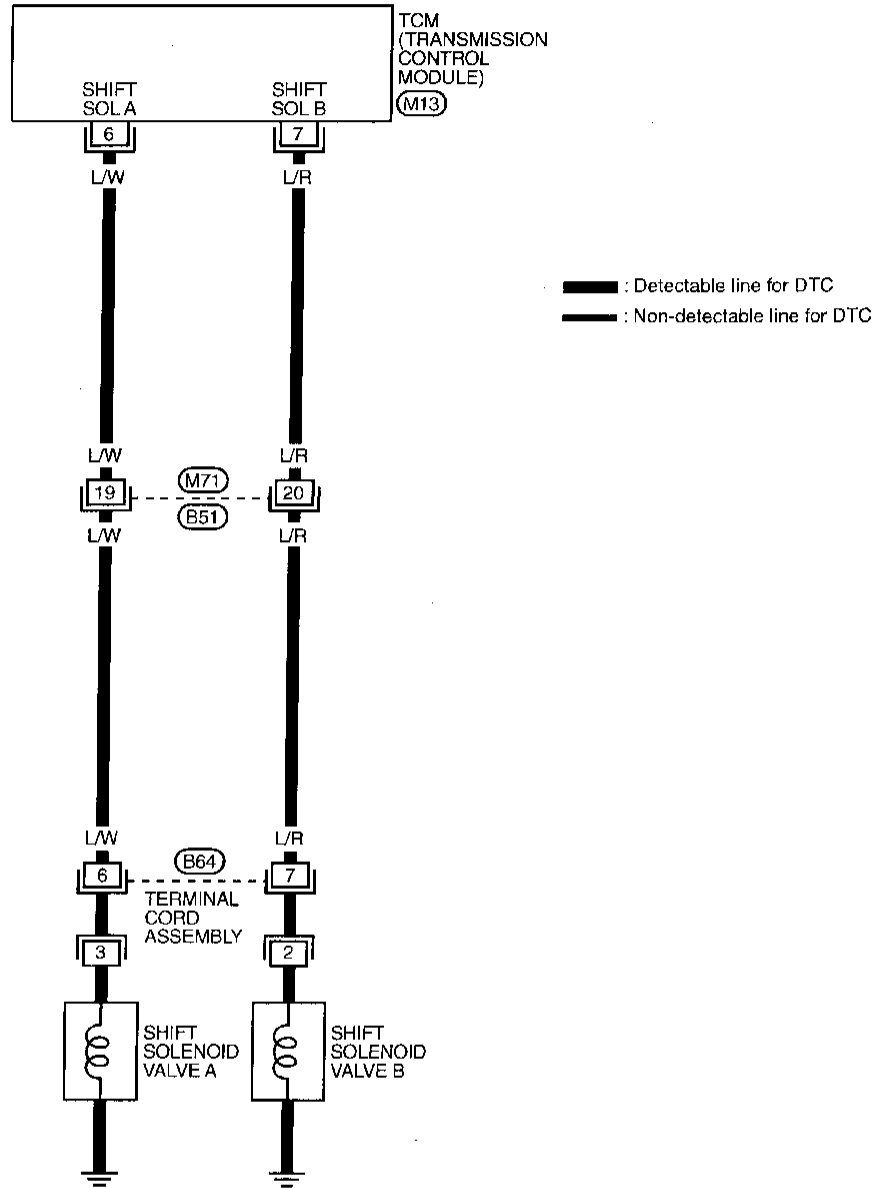

* : This connector is not shown in "HARNESS LAYOUT" in EL section.

MAT558A

Diagnostic Procedure

NAAT0040

CI
MA
EM
LC
EC
FE
CL
MT
AT
TF
PD
AX
SU
BR
ST
RS
BT
HA
SC
EL
IDX

1	CHECK SHIFT SOLENOID VALVE
<p>1. Remove control valve assembly. Refer to AT-225.</p> <p>2. Check shift solenoid valve operation.</p> <ul style="list-style-type: none"> • Shift solenoid valve A • Shift solenoid valve B <p>Refer to "Component Inspection", AT-110.</p>	
OK or NG	
OK	▶ GO TO 2.
NG	▶ Repair or replace shift solenoid valve assembly.

2	CHECK CONTROL VALVE
<p>1. Disassemble control valve assembly. Refer to "Control Valve Assembly", AT-250.</p> <p>2. Check to ensure that:</p> <ul style="list-style-type: none"> • Valve, sleeve and plug slide along valve bore under their own weight. • Valve, sleeve and plug are free from burrs, dents and scratches. • Control valve springs are free from damage, deformation and fatigue. • Hydraulic line is free from obstacles. 	
OK or NG	
OK	▶ GO TO 3.
NG	▶ Repair control valve assembly.

3	CHECK DTC
<p>Perform Diagnostic Trouble Code (DTC) confirmation procedure, AT-106.</p>	
OK or NG	
OK	▶ INSPECTION END
NG	▶ Check control valve again. Repair or replace control valve assembly.

DTC P0731 IMPROPER SHIFTING TO 1ST GEAR POSITION

Component Inspection

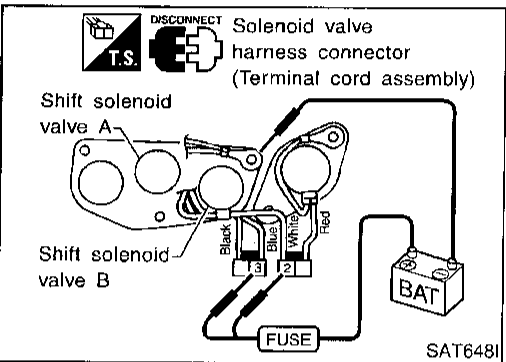
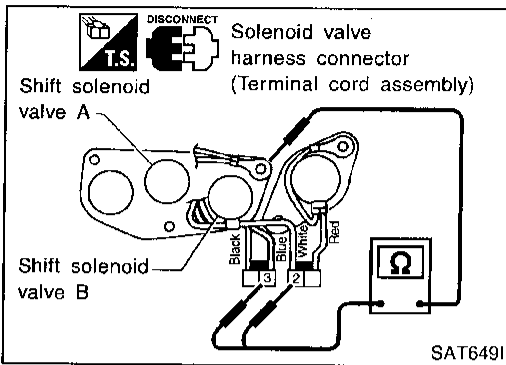

Component Inspection

SHIFT SOLENOID VALVE A AND B

=NAAT0041

NAAT0041S01

- For removal, refer to AT-225.

Resistance Check

NAAT0041S0101

- Check resistance between terminals (3 or 2) and ground.

Solenoid valve	Terminal No.	Resistance (Approx.)
Shift solenoid valve A	3	20 - 40Ω
Shift solenoid valve B	2	

Operation Check

NAAT0041S0102

- Check solenoid valve by listening for its operating sound while applying battery voltage to the terminals (3 or 2) and ground.

DTC P0732 IMPROPER SHIFTING TO 2ND GEAR POSITION

Description

Description

- This is an OBD-II self-diagnostic item and not available in TCM self-diagnosis.
- This malfunction will not be detected while the O/D OFF indicator lamp is indicating another self-diagnosis malfunction.
- This malfunction is detected when the A/T does not shift into second gear position as instructed by the TCM. This is not caused by electrical malfunction (circuits open or shorted) but by mechanical malfunction such as control valve sticking, improper solenoid valve operation, etc.

Gear position	1	2	3	4
Shift solenoid valve A	ON (Closed)	OFF (Open)	OFF (Open)	ON (Closed)
Shift solenoid valve B	ON (Closed)	ON (Closed)	OFF (Open)	OFF (Open)

TCM TERMINALS AND REFERENCE VALUE

Remarks: Specification data are reference values.

Terminal No.	Wire color	Item	Condition	Judgement standard	
7	L/R	Shift solenoid valve B		When shift solenoid valve B operates. (When driving in "D ₁ " or "D ₂ ".)	Battery voltage
				When shift solenoid valve B does not operate. (When driving in "D ₃ " or "D ₄ ".)	1V or less

ON BOARD DIAGNOSIS LOGIC

This diagnosis monitors actual gear position by checking the torque converter slip ratio calculated by TCM as follows:

Torque converter slip ratio = A x C/B

A: Output shaft revolution signal from revolution sensor

B: Engine speed signal from ECM

C: Gear ratio determined as gear position which TCM supposes
 If the actual gear position is higher than the position (2nd) supposed by TCM, the slip ratio will be more than normal. In case the ratio exceeds the specified value, TCM judges this diagnosis malfunction.

This malfunction will be caused when shift solenoid valve B is stuck open.

Gear position supposed by TCM	1	2	3	4
In case of gear position with no malfunctions	1	2	3	4
In case of gear position with shift solenoid valve B stuck open	4	3*	3	4

*: P0732 is detected.

Diagnostic trouble code	Malfunction is detected when ...	Check item (Possible cause)
(P) : A/T 2ND SIGNAL (P) : P0732 (M) : MIL Code No. 1104	A/T cannot be shifted to the 2nd gear position even if electrical circuit is good.	<ul style="list-style-type: none"> • Shift solenoid valve B • Each clutch • Hydraulic control circuit

DTC P0732 IMPROPER SHIFTING TO 2ND GEAR POSITION

Description (Cont'd)

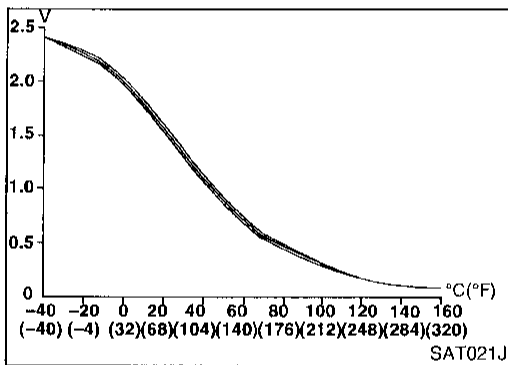
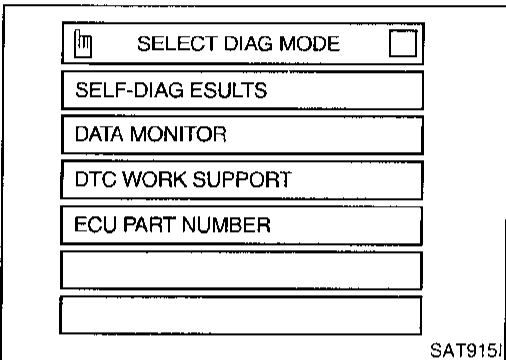
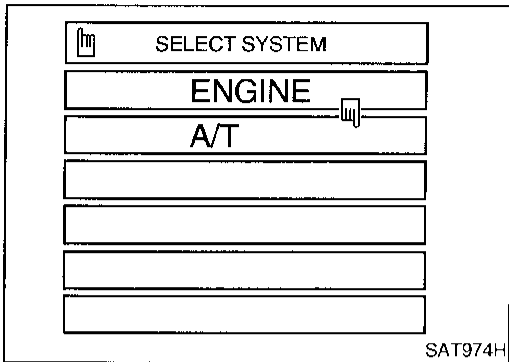

DIAGNOSTIC TROUBLE CODE (DTC) CONFIRMATION PROCEDURE

NAA70042501

CAUTION:

- Always drive vehicle at a safe speed.
- Be careful not to rev engine into the red zone on the tachometer.

NOTE:

If "DIAGNOSTIC TROUBLE CODE CONFIRMATION PROCEDURE" has been previously conducted, always turn ignition switch "OFF" and wait at least 5 seconds before conducting the next test.

TESTING CONDITIONS:

Always drive vehicle on a level road to improve the accuracy of test.

After the repair, perform the following procedure to confirm the malfunction is eliminated.

④ With CONSULT

- 1) Start engine and select "DATA MONITOR" mode for "A/T" with CONSULT.
- 2) Make sure that output voltage of A/T fluid temperature sensor is within the range below.

FLUID TEMP SEN: 0.4 - 1.5V

If out of range, drive the vehicle to decrease the voltage (warm up the fluid) or stop engine to increase the voltage (cool down the fluid).

- 3) Select "2ND GR FNCTN P0732" of "DTC WORK SUPPORT" mode for "A/T" with CONSULT and touch "START".
- 4) Accelerate vehicle to 52 to 57 km/h (32 to 35 MPH) under the following condition and release the accelerator pedal completely.

THROTTLE POSI: Less than 1/8 (at all times during step 4)
Selector lever: D position (OD "ON")

- Check that "GEAR" shows "3" or "4" after releasing pedal.
- 5) Depress accelerator pedal to WOT (more than 7/8 of "THROTTLE POSI") quickly from a speed of 52 to 57 km/h (32 to 35 MPH) until "TESTING" changes to "STOP VEHICLE" or "COMPLETED". (It will take approximately 3 seconds.)

If the check result NG appears on CONSULT screen, go to "DIAGNOSTIC PROCEDURE", AT-115.

If "STOP VEHICLE" appears on CONSULT screen, go to following step.

- Check that "GEAR" shows "2" when depressing accelerator pedal to WOT.
- If "TESTING" does not appear on CONSULT for a long time, select "SELF-DIAG RESULTS" for "ENGINE". In case a 1st trip DTC other than P0732 is shown, refer to applicable "TROUBLE DIAGNOSIS FOR DTC".

- 6) Stop vehicle.
- 7) Follow the instruction displayed. (Check for normal shifting referring to the table below.)

Vehicle condition	Gear on actual transmission shift pattern when screen is changed to 1 → 2 → 3 → 4
No malfunction exists	1 → 2 → 3 → 4
Malfunction for P0732 exists.	4 → 3 → 3 → 4

- 8) Make sure that "OK" is displayed. (If "NG" is displayed, refer

DTC P0732 IMPROPER SHIFTING TO 2ND GEAR POSITION

Description (Cont'd)

to "DIAGNOSTIC PROCEDURE".) Refer to "DIAGNOSTIC PROCEDURE", AT-115. Refer to shift schedule, AT-307.

 **With GST**

- 1) Start engine and warm up ATF.
- 2) Accelerate vehicle to 52 to 57 km/h (32 to 35 MPH) under the following condition and release the accelerator pedal completely.

THROTTLE POSI: Less than 1/8

Selector lever: D position (OD "ON")

Refer to shift schedule, AT-307.

- 3) Depress accelerator pedal to WOT (more than 7/8 of "THROTTLE POSI") quickly from a speed of 52 to 57 km/h (32 to 35 MPH). (It will take approximately 3 seconds.)
- 4) Select "MODE 7" with GST.

 **No Tools**

- 1) Start engine and warm up ATF.
- 2) Accelerate vehicle to 52 to 57 km/h (32 to 35 MPH) under the following condition and release the accelerator pedal completely.

THROTTLE POSI: Less than 1/8

Selector lever: D position (OD "ON")

Refer to shift schedule, AT-307.

- 3) Depress accelerator pedal to WOT (more than 7/8 of "THROTTLE POSI") quickly from a speed of 52 to 57 km/h (32 to 35 MPH). (It will take approximately 3 seconds.)
- 4) Perform self-diagnosis for ECM.
Refer to EC section ["Malfunction Indicator Lamp (MIL)", "ON BOARD DIAGNOSTIC SYSTEM DESCRIPTION"].

GI

MA

EM

LC

EC

FE

CL

MT

AT

TF

PD

AX

SU

BR

ST

RS

BT

HA

SC

EL

IDX

DTC P0732 IMPROPER SHIFTING TO 2ND GEAR POSITION

Wiring Diagram — AT — 2ND

Wiring Diagram — AT — 2ND

NAAT0191

AT-2NDSIG-01

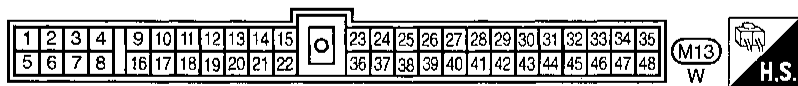
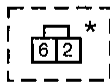
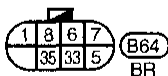
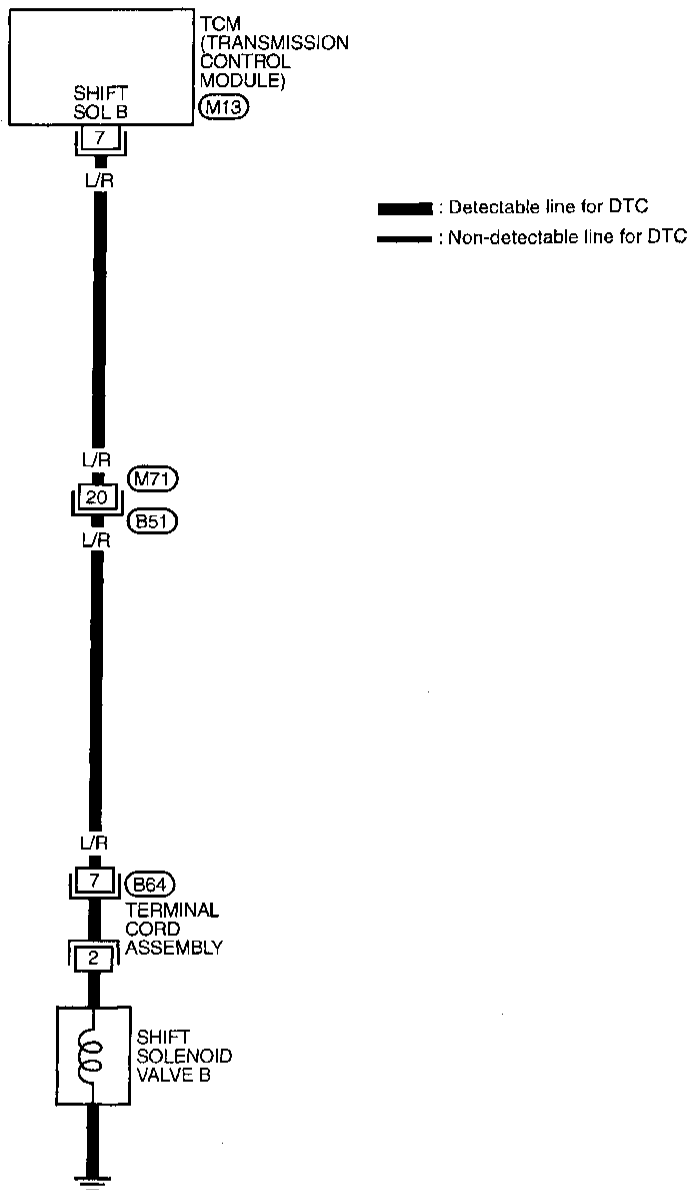

* : This connector is not shown in "HARNESS LAYOUT" in EL section.

MAT559A

Diagnostic Procedure

NAAT0043

GI

MA

EM

LC

EC

FE

CL

MT

AT

TF

PD

AX

SU

BR

ST

RS

BT

HA

SC

EL

IDX

1	CHECK SHIFT SOLENOID VALVE
<p>1. Remove control valve assembly. Refer to AT-225. 2. Check shift solenoid valve operation. ● Shift solenoid valve B Refer to "Component Inspection", AT-115.</p>	
<p style="text-align: right;">Solenoid valve harness connector (Terminal cord assembly)</p> <p style="text-align: center;">Shift solenoid valve B</p> <p style="text-align: center;">OK or NG</p>	
OK	▶ GO TO 2.
NG	▶ Repair or replace shift solenoid valve assembly.

2	CHECK CONTROL VALVE
<p>1. Disassemble control valve assembly. Refer to "Control Valve Assembly", AT-250. 2. Check to ensure that: ● Valve, sleeve and plug slide along valve bore under their own weight. ● Valve, sleeve and plug are free from burrs, dents and scratches. ● Control valve springs are free from damage, deformation and fatigue. ● Hydraulic line is free from obstacles.</p>	
<p style="text-align: right;">SAT367H</p> <p style="text-align: center;">OK or NG</p>	
OK	▶ GO TO 3.
NG	▶ Repair control valve assembly.

3	CHECK DTC
<p>Perform Diagnostic Trouble Code (DTC) confirmation procedure, AT-112.</p> <p style="text-align: center;">OK or NG</p>	
OK	▶ INSPECTION END
NG	▶ Check control valve again. Repair or replace control valve assembly.

Solenoid valve harness connector (Terminal cord assembly)

Shift solenoid valve B

SAT651I

Component Inspection SHIFT SOLENOID VALVE B

NAAT0044

NAAT0044S01

- For removal, refer to AT-225.

Resistance Check

NAAT0044S0101

- Check resistance between terminal 2 and ground.

Solenoid valve	Terminal No.	Resistance (Approx.)
Shift solenoid valve B	2 Ground	20 - 40Ω

DTC P0732 IMPROPER SHIFTING TO 2ND GEAR POSITION

Component Inspection (Cont'd)

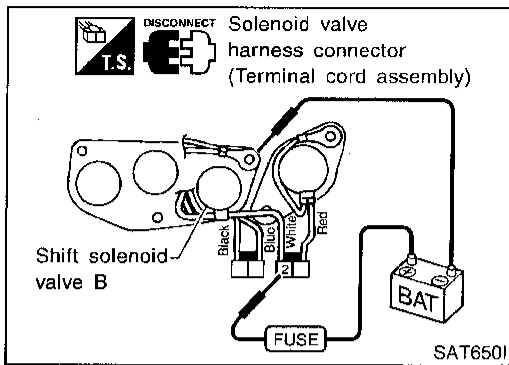

Operation Check

NAA7004450102

- Check solenoid valve by listening for its operating sound while applying battery voltage to the terminal 2 and ground.

DTC P0733 IMPROPER SHIFTING TO 3RD GEAR POSITION

Description

Description

- This is an OBD-II self-diagnostic item and not available in TCM self-diagnosis.
- This malfunction will not be detected while the O/D OFF indicator lamp is indicating another self-diagnosis malfunction.
- This malfunction is detected when the A/T does not shift into third gear position as instructed by the TCM. This is not caused by electrical malfunction (circuits open or shorted) but by mechanical malfunction such as control valve sticking, improper solenoid valve operation, malfunctioning servo piston or brake band, etc.

NAAT0045

GI
MA
EM
LC
EC
FE
CL
MT
AT
TF
PD
AX
SU
BR
ST
RS
BT
HA
SC
EL
IDX

Gear position	1	2	3	4
Shift solenoid valve A	ON (Closed)	OFF (Open)	OFF (Open)	ON (Closed)
Shift solenoid valve B	ON (Closed)	ON (Closed)	OFF (Open)	OFF (Open)

TCM TERMINALS AND REFERENCE VALUE

NAAT0045S02

Remarks: Specification data are reference values.

Terminal No.	Wire color	Item	Condition	Judgement standard
6	L/W	Shift solenoid valve A	 When shift solenoid valve A operates. (When driving in "D ₁ " or "D ₄ ".)	Battery voltage
			When shift solenoid valve A does not operate. (When driving in "D ₂ " or "D ₃ ".)	1V or less

ON BOARD DIAGNOSIS LOGIC

NAAT0045S03

This diagnosis monitors actual gear position by checking the torque converter slip ratio calculated by TCM as follows:

$$\text{Torque converter slip ratio} = A \times C/B$$

A: Output shaft revolution signal from revolution sensor

B: Engine speed signal from ECM

C: Gear ratio determined as gear position which TCM supposes
If the actual gear position is higher than the position (3rd) supposed by TCM, the slip ratio will be more than normal. In case the ratio exceeds the specified value, TCM judges this diagnosis malfunction.

This malfunction will be caused when shift solenoid valve A is stuck closed.

Gear position supposed by TCM	1	2	3	4
In case of gear position with no malfunctions	1	2	3	4
In case of gear position with shift solenoid valve A stuck closed	1	1	4*	4

*: P0733 is detected.

Diagnostic trouble code	Malfunction is detected when ...	Check item (Possible cause)
(P) : A/T 3RD GR FNCTN (P) : P0733 (MIL) : MIL Code No. 1105	A/T cannot be shifted to the 3rd gear position even if electrical circuit is good.	<ul style="list-style-type: none"> • Shift solenoid valve A • Each clutch • Hydraulic control circuit

DTC P0733 IMPROPER SHIFTING TO 3RD GEAR POSITION

Description (Cont'd)

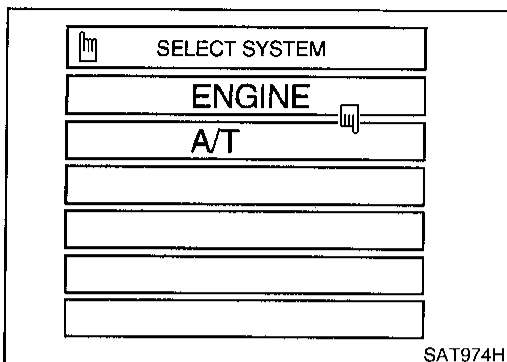

SAT974H

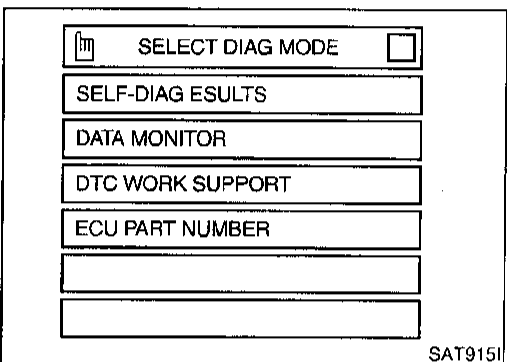

SAT915I

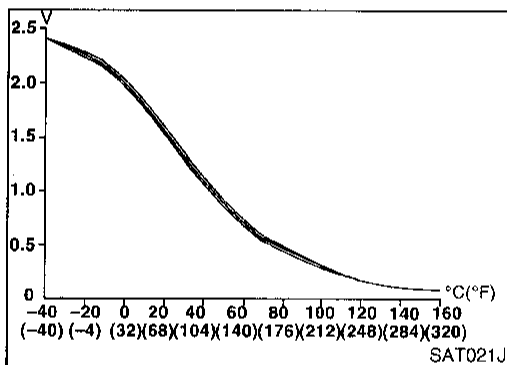

SAT021J

DIAGNOSTIC TROUBLE CODE (DTC) CONFIRMATION PROCEDURE

NAAT0045S01

CAUTION:

- Always drive vehicle at a safe speed.
- Be careful not to rev engine into the red zone on the tachometer.

NOTE:

If "DIAGNOSTIC TROUBLE CODE CONFIRMATION PROCEDURE" has been previously conducted, always turn ignition switch "OFF" and wait at least 5 seconds before conducting the next test.

TESTING CONDITIONS:

Always drive vehicle on a level road to improve the accuracy of test.

After the repair, perform the following procedure to confirm the malfunction is eliminated.

With CONSULT

1) Start engine and select "DATA MONITOR" mode for "A/T" with CONSULT.

2) Make sure that output voltage of A/T fluid temperature sensor is within the range below.

FLUID TEMP SEN: 0.4 - 1.5V

If out of range, drive the vehicle to decrease the voltage (warm up the fluid) or stop engine to increase the voltage (cool down the fluid).

3) Select "3RD GR FNCTN P0733" of "DTC WORK SUPPORT" mode for "A/T" with CONSULT and touch "START".

4) Accelerate vehicle to 75 to 90 km/h (47 to 56 MPH) under the following condition and release the accelerator pedal completely.

THROTTLE POSI: Less than 1/8 (at all times during step 4)
Selector lever: D position (OD "ON")

• Check that "GEAR" shows "4" after releasing pedal.

5) Depress accelerator pedal steadily with 3.5/8 - 4.5/8 of "THROTTLE POSI" from a speed of 75 to 90 km/h (47 to 56 MPH) until "TESTING" changes to "STOP VEHICLE" or "COMPLETED". (It will take approximately 3 seconds.)

If the check result NG appears on CONSULT screen, go to "DIAGNOSTIC PROCEDURE", AT-121.

If "STOP VEHICLE" appears on CONSULT screen, go to following step.

• Check that "GEAR" shows "3" when depressing accelerator pedal with 3.5/8 - 4.5/8 of "THROTTLE POSI".

• If "TESTING" does not appear on CONSULT for a long time, select "SELF-DIAG RESULTS" for "ENGINE". In case a 1st trip DTC other than P0733 is shown, refer to applicable "TROUBLE DIAGNOSIS FOR DTC".

6) Stop vehicle.



7) Follow the instruction displayed. (Check for normal shifting referring to the table below.)

Vehicle condition	Gear on actual transmission shift pattern when screen is changed to 1 → 2 → 3 → 4
No malfunction exists.	1 → 2 → 3 → 4
Malfunction for P0733 exists.	1 → 1 → 4 → 4

8) Make sure that "OK" is displayed. (If "NG" is displayed, refer

DTC P0733 IMPROPER SHIFTING TO 3RD GEAR POSITION

Description (Cont'd)

- to "DIAGNOSTIC PROCEDURE".) Refer to "DIAGNOSTIC PROCEDURE", AT-121.
Refer to shift schedule, AT-307.
-  **With GST**
- 1) Start engine and warm up ATF.
 - 2) Accelerate vehicle to 75 to 90 km/h (47 to 56 MPH) under the following condition and release the accelerator pedal completely.
THROTTLE POSI: Less than 1/8
Selector lever: D position (OD "ON")
Refer to shift schedule, AT-307.
 - 3) Depress accelerator pedal with 3.5/8 - 4.5/8 of "THROTTLE POSI" from a speed of 75 to 90 km/h (47 to 56 MPH). (It will take approximately 3 seconds.)
 - 4) Select "MODE 7" with GST.
-  **No Tools**
- 1) Start engine and warm up ATF.
 - 2) Accelerate vehicle to 75 to 90 km/h (47 to 56 MPH) under the following condition and release the accelerator pedal completely.
THROTTLE POSI: Less than 1/8
Selector lever: D position (OD "ON")
Refer to shift schedule, AT-307.
 - 3) Depress accelerator pedal with 3.5/8 - 4.5/8 of "THROTTLE POSI" from a speed of 75 to 90 km/h (45 to 56 MPH). (It will take approximately 3 seconds.)
 - 4) Perform self-diagnosis for ECM.
Refer to EC section ["Malfunction Indicator Lamp (MIL)", "ON BOARD DIAGNOSTIC SYSTEM DESCRIPTION"].

GI
MA
EM
LC
EC
FE
CL
MT
AT
TF
PD
AX
SU
BR
ST
RS
BT
HA
SC
EL
IDX

DTC P0733 IMPROPER SHIFTING TO 3RD GEAR POSITION

Wiring Diagram — AT — 3RD

Wiring Diagram — AT — 3RD

NAA10192

AT-3RDSIG-01

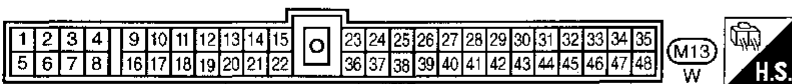
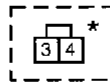
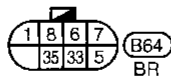
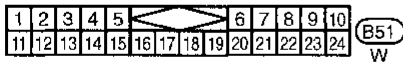
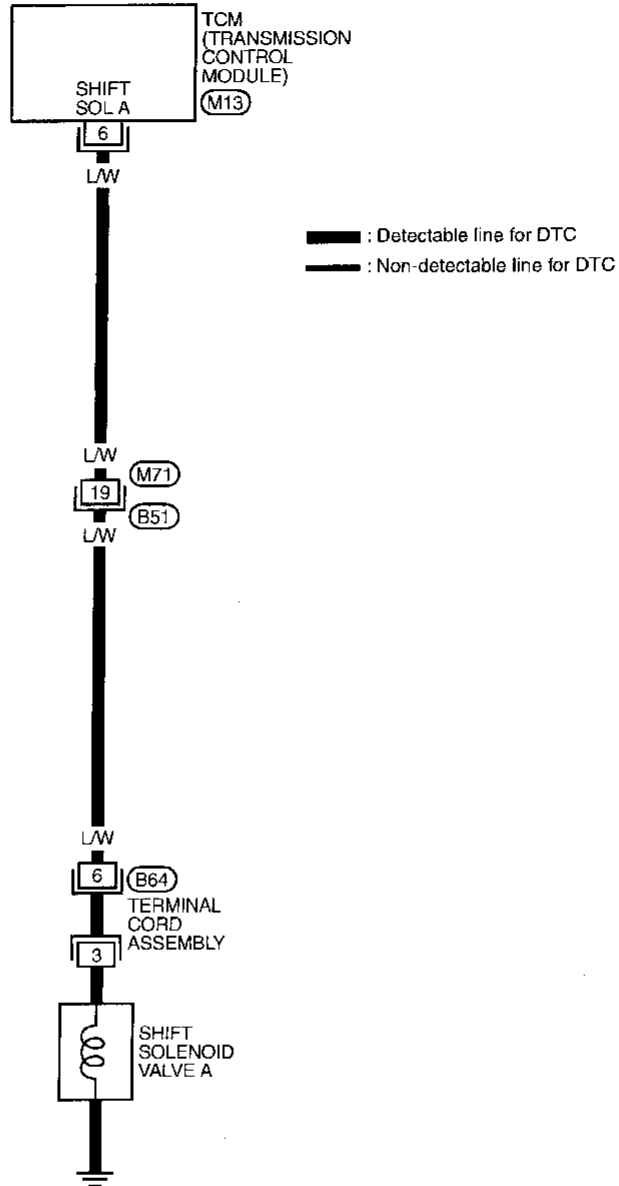

* : This connector is not shown in "HARNESS LAYOUT" in EL section.

MAT560A

Diagnostic Procedure

NAAT0046

GI
MA
EM
LC
EC
FE
CL
MT
AT
TF
PD
AX
SU
BR
ST
RS
BT
HA
SC
EL
IDX

1	CHECK SHIFT SOLENOID VALVE
<p>1. Remove control valve assembly. Refer to AT-225. 2. Check shift solenoid valve operation. ● Shift solenoid valve A Refer to "Component Inspection", AT-121.</p>	
<p style="text-align: right;">Solenoid valve harness connector (Terminal cord assembly)</p> <p style="text-align: center;">Shift solenoid valve A</p> <p style="text-align: center;">OK or NG</p> <p style="text-align: right;">SAT653I</p>	
OK	▶ GO TO 2.
NG	▶ Repair or replace shift solenoid valve assembly.

2	CHECK CONTROL VALVE
<p>1. Disassemble control valve assembly. Refer to "Control Valve Assembly", AT-250. 2. Check to ensure that: ● Valve, sleeve and plug slide along valve bore under their own weight. ● Valve, sleeve and plug are free from burrs, dents and scratches. ● Control valve springs are free from damage, deformation and fatigue. ● Hydraulic line is free from obstacles.</p>	
<p style="text-align: right;">SAT367H</p> <p style="text-align: center;">OK or NG</p>	
OK	▶ GO TO 3.
NG	▶ Repair control valve assembly.

3	CHECK DTC
<p>Perform Diagnostic Trouble Code (DTC) confirmation procedure, AT-118.</p> <p style="text-align: center;">OK or NG</p>	
OK	▶ INSPECTION END
NG	▶ Check control valve again. Repair or replace control valve assembly.

Solenoid valve harness connector (Terminal cord assembly)

Shift solenoid valve A

SAT654I

Component Inspection SHIFT SOLENOID VALVE A

NAAT0047

NAAT0047S01

Resistance Check

NAAT0047S0101

- Check resistance between terminal 3 and ground.

Solenoid valve	Terminal No.	Resistance (Approx.)
Shift solenoid valve A	3 Ground	20 - 40Ω

DTC P0733 IMPROPER SHIFTING TO 3RD GEAR POSITION

Component Inspection (Cont'd)

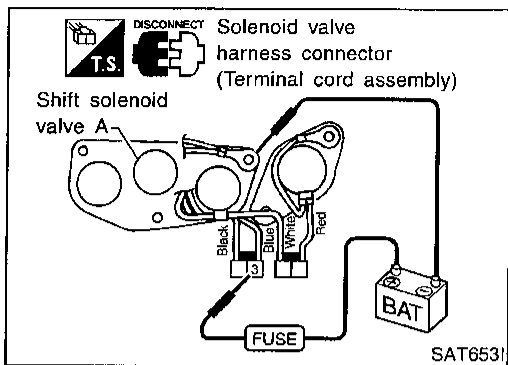

Operation Check

NAAT0047S0102

- Check solenoid valve by listening for its operating sound while applying battery voltage to the terminal 3 and ground.

DTC P0734 IMPROPER SHIFTING TO 4TH GEAR POSITION

Description

Description

- This is an OBD-II self-diagnostic item and not available in TCM self-diagnosis.
- This malfunction will not be detected while the O/D OFF indicator lamp is indicating another self-diagnosis malfunction.
- This malfunction is detected when the A/T does not shift into fourth gear position or the torque converter clutch does not lock up as instructed by the TCM. This is not caused by electrical malfunction (circuits open or shorted) but by mechanical malfunction such as control valve sticking, improper solenoid valve operation, malfunctioning oil pump or torque converter clutch, etc.

CONSULT REFERENCE VALUE IN DATA MONITOR MODE

Remarks: Specification data are reference values.

Monitor item	Condition	Specification
Torque converter clutch solenoid valve duty	Lock-up "OFF"	Approximately 4%
	↓ Lock-up "ON"	↓ Approximately 94%
Line pressure solenoid valve duty	Small throttle opening (Low line pressure)	Approximately 24%
	↓ Large throttle opening (High line pressure)	↓ Approximately 95%

Gear position	1	2	3	4
Shift solenoid valve A	ON (Closed)	OFF (Open)	OFF (Open)	ON (Closed)
Shift solenoid valve B	ON (Closed)	ON (Closed)	OFF (Open)	OFF (Open)

TCM TERMINALS AND REFERENCE VALUE

Remarks: Specification data are reference values.

Terminal No.	Wire color	Item	Condition	Judgement standard
1	GY	Line pressure solenoid valve	When releasing accelerator pedal after warming up engine.	1.5 - 2.5V
			When depressing accelerator pedal fully after warming up engine.	0.5V or less
2	BR/Y	Line pressure solenoid valve (with dropping resistor)	When releasing accelerator pedal after warming up engine.	5 - 14V
			When depressing accelerator pedal fully after warming up engine.	0.5V or less

DTC P0734 IMPROPER SHIFTING TO 4TH GEAR POSITION

Description (Cont'd)

Terminal No.	Wire color	Item	Condition	Judgement standard
5	G/OR	Torque converter clutch solenoid valve	When A/T performs lock-up.	8 - 15V
			When A/T does not perform lock-up.	1V or less
6	L/W	Shift solenoid valve A	When shift solenoid valve A operates. (When driving in "D ₁ " or "D ₄ ".)	Battery voltage
			When shift solenoid valve A does not operate. (When driving in "D ₂ " or "D ₃ ".)	1V or less
7	L/R	Shift solenoid valve B	When shift solenoid valve B operates. (When driving in "D ₁ " or "D ₂ ".)	Battery voltage
			When shift solenoid valve B does not operate. (When driving in "D ₃ " or "D ₄ ".)	1V or less
8	L/B	Overrun clutch solenoid valve	When overrun clutch solenoid valve operates.	Battery voltage
			When overrun clutch solenoid valve does not operate.	1V or less



ON BOARD DIAGNOSIS LOGIC

NAA70048S03

This diagnosis monitors actual gear position by checking the torque converter slip ratio calculated by TCM as follows:

Torque converter slip ratio = A x C/B

A: Output shaft revolution signal from revolution sensor

B: Engine speed signal from ECM

C: Gear ratio determined as gear position which TCM supposes
If the actual gear position is much lower than the position (4th) supposed by TCM, the slip ratio will be much less than normal. In case the ratio does not reach the specified value, TCM judges this diagnosis malfunction.

This malfunction will be caused when shift solenoid valve B is stuck closed.

Gear position supposed by TCM	1	2	3	4
In case of gear position with no malfunctions	1	2	3	4
In case of gear position with shift solenoid valve B stuck closed	1	2	2	1*

*: P0734 is detected.

Diagnostic trouble code	Malfunction is detected when ...	Check item (Possible cause)
Ⓜ : A/T 4TH GR FNCTN	A/T cannot be shifted to the 4th gear position even if electrical circuit is good.	<ul style="list-style-type: none"> ● Shift solenoid valve A ● Shift solenoid valve B ● Overrun clutch solenoid valve ● Line pressure solenoid valve ● Each clutch ● Hydraulic control circuit ● Torque converter clutch solenoid valve
Ⓜ : P0734		
Ⓜ : MIL Code No. 1106		

DTC P0734 IMPROPER SHIFTING TO 4TH GEAR POSITION

Description (Cont'd)

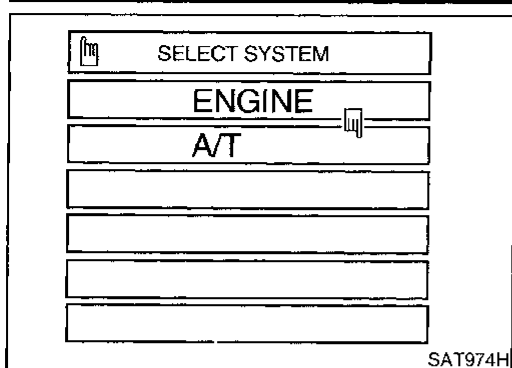

SAT974H

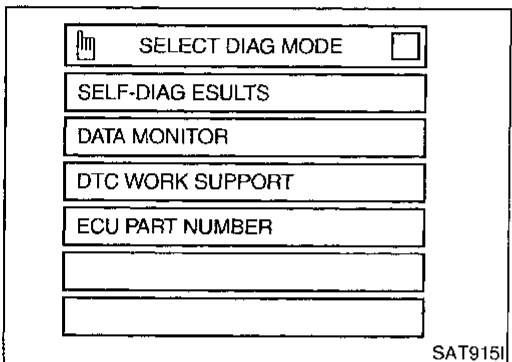

SAT915I

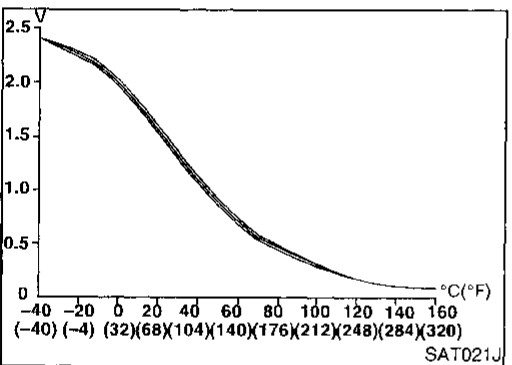

SAT021J

DIAGNOSTIC TROUBLE CODE (DTC) CONFIRMATION PROCEDURE

NAAT004BS01

CAUTION:

- Always drive vehicle at a safe speed.
- Be careful not to rev engine into the red zone on the tachometer.

NOTE:

If "DIAGNOSTIC TROUBLE CODE CONFIRMATION PROCEDURE" has been previously conducted, always turn ignition switch "OFF" and wait at least 5 seconds before conducting the next test.

TESTING CONDITIONS:

Always drive vehicle on a level road to improve the accuracy of test.

After the repair, perform the following procedure to confirm the malfunction is eliminated.

① With CONSULT

1) Start engine and select "DATA MONITOR" mode for "A/T" with CONSULT.

2) Make sure that output voltage of A/T fluid temperature sensor is within the range below.

FLUID TEMP SEN: 0.4 - 1.5V

If out of range, drive the vehicle to decrease the voltage (warm up the fluid) or stop engine to increase the voltage (cool down the fluid).

3) Select "4TH GR FNCTN P0734" of "DTC WORK SUPPORT" mode for "A/T" with CONSULT and touch "START".

4) Accelerate vehicle to 45 to 55 km/h (28 to 34 MPH) under the following condition and release the accelerator pedal completely.

THROTTLE POSI: Less than 5.5/8 (at all times during step 4)

Selector lever: D position (OD "ON")

- Check that "GEAR" shows "3" after releasing pedal.

5) Depress accelerator pedal steadily with 1/8 - 2/8 of "THROTTLE POSI" from a speed of 45 to 55 km/h (28 to 34 MPH) until "TESTING" has turned to "STOP VEHICLE" or "COMPLETED". (It will take approximately 3 seconds.)

If the check result NG appears on CONSULT screen, go to "DIAGNOSTIC PROCEDURE", AT-128.

If "STOP VEHICLE" appears on CONSULT screen, go to following step.

- Check that "GEAR" shows "4" when depressing accelerator pedal with 1/8 - 2/8 of "THROTTLE POSI".

- If "TESTING" does not appear on CONSULT for a long time, select "SELF-DIAG RESULTS" for "ENGINE". In case a 1st trip DTC other than P0734 is shown, refer to applicable "TROUBLE DIAGNOSIS FOR DTC".

6) Stop vehicle.

7) Follow the instruction displayed. (Check for normal shifting referring to the table below.)

Vehicle condition	Gear on actual transmission shift pattern when screen is changed to 1 → 2 → 3 → 4
No malfunction exists	1 → 2 → 3 → 4
Malfunction for P0734 exists.	1 → 2 → 2 → 1

DTC P0734 IMPROPER SHIFTING TO 4TH GEAR POSITION

Description (Cont'd)

- 8) Make sure that "OK" is displayed. (If "NG" is displayed, refer to "DIAGNOSTIC PROCEDURE".) Refer to "DIAGNOSTIC PROCEDURE", AT-128.
Refer to shift schedule, AT-307.

With GST

- 1) Start engine and warm up ATF.
- 2) Accelerate vehicle to 45 to 55 km/h (28 to 34 MPH) under the following condition and release the accelerator pedal completely.
THROTTLE POSI: Less than 5.5/8
Selector lever: D position (OD "ON")
Refer to shift schedule, AT-307.
- 3) Depress accelerator pedal with 1/8 - 2/8 of "THROTTLE POSI" from a speed of 45 to 55 km/h (28 to 34 MPH). (It will take approximately 3 seconds.)
- 4) Select "MODE 7" with GST.

No Tools

- 1) Start engine and warm up ATF.
- 2) Accelerate vehicle to 45 to 55km/h (28 to 34PH) under the following condition and release the accelerator pedal completely.
THROTTLE POSI: Less than 5.5/8
Selector lever: D position (OD "ON")
Refer to shift schedule, AT-307.
- 3) Depress accelerator pedal with 1/8 - 2/8 of "THROTTLE POSI" from a speed of 45 to 55 km/h (28 to 34 MPH). (It will take approximately 3 seconds.)
- 4) Perform self-diagnosis for ECM.
Refer to EC section ["Malfunction Indicator Lamp (MIL)", "ON BOARD DIAGNOSTIC SYSTEM DESCRIPTION"].

DTC P0734 IMPROPER SHIFTING TO 4TH GEAR POSITION

Wiring Diagram — AT — 4TH

Wiring Diagram — AT — 4TH

NAAT0193

AT-4THSIG-01

: Detectable line for DTC
 : Non-detectable line for DTC

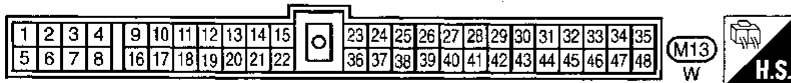
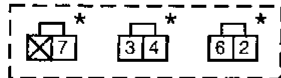
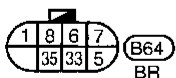
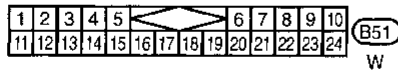
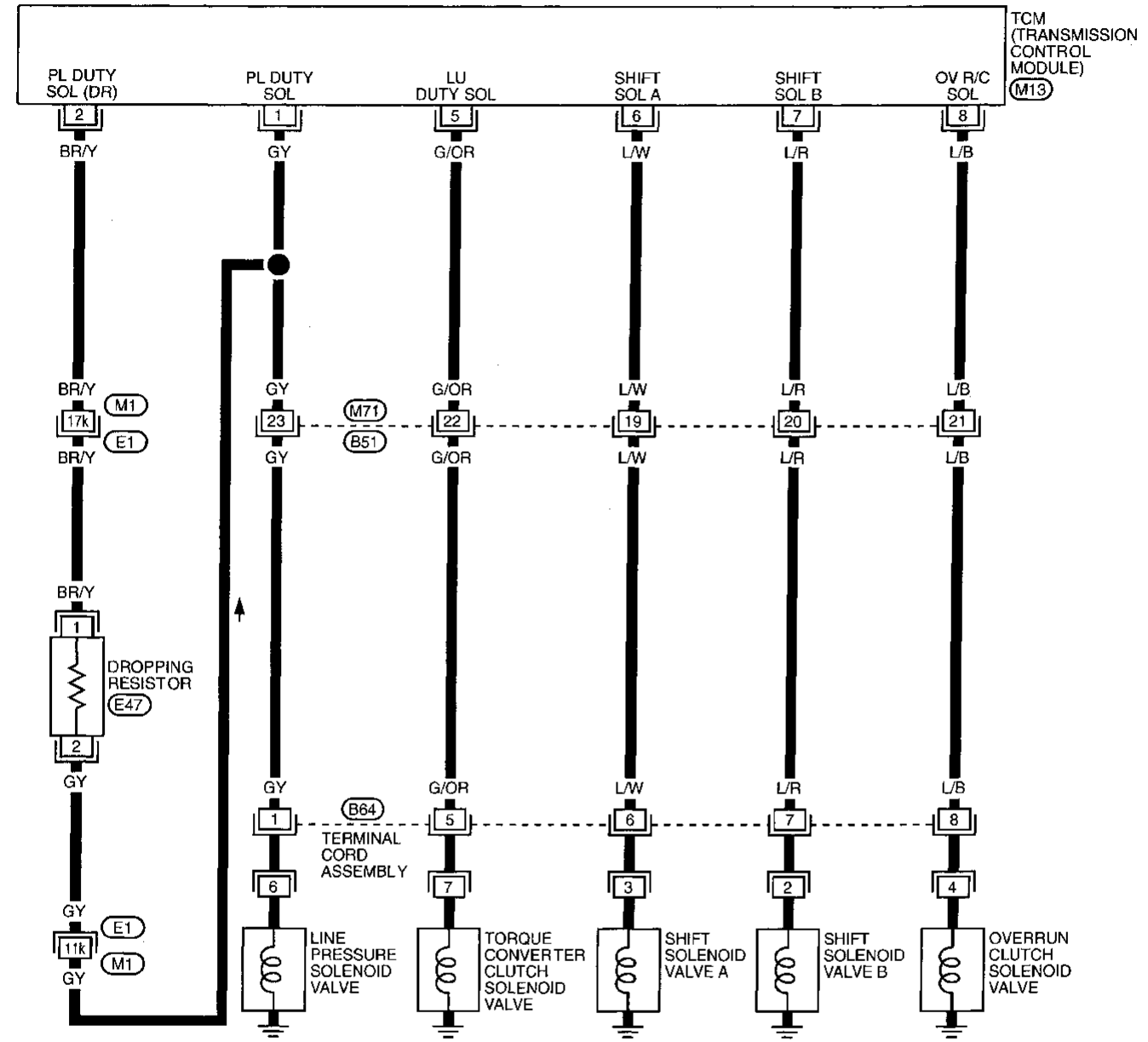

*: This connector is not shown in "HARNESS LAYOUT" in EL section.

Refer to last page (Foldout page).

(M1), (E1)

GI
MA
EM
LC
EC
FE
CL
MT
AT
TF
PD
AX
SU
BR
ST
RS
BT
HA
SC
EL
IDX

MAT561A

DTC P0734 IMPROPER SHIFTING TO 4TH GEAR POSITION

Diagnostic Procedure

Diagnostic Procedure

NAAT0049

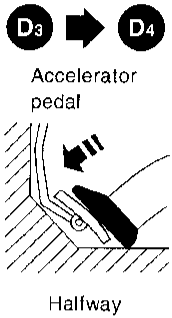
1	CHECK SHIFT UP (D₃ TO D₄)
<p>During "Cruise test – Part 1", AT-64. Does A/T shift from D₃ to D₄ at the specified speed?</p>	
	
SAT988H	
Yes or No	
Yes	<ul style="list-style-type: none"> ▶ GO TO 11. ▶ And check for proper lock-up.
No	▶ GO TO 2.

2	CHECK LINE PRESSURE
<p>Perform line pressure test. Refer to AT-57.</p>	
OK or NG	
OK	▶ GO TO 3.
NG	▶ GO TO 7.

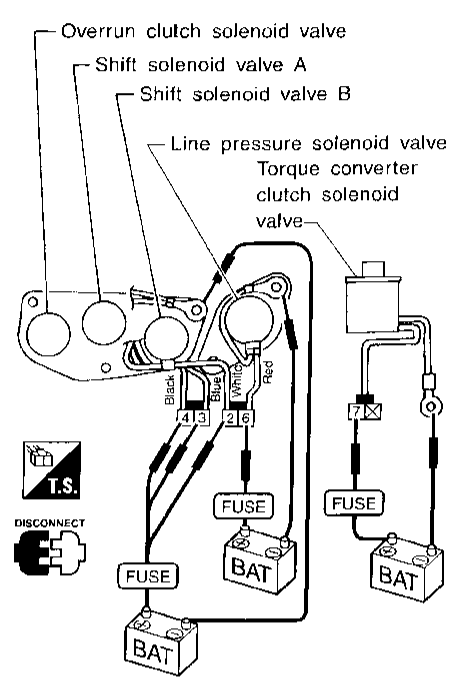
3	CHECK SOLENOID VALVES
<p>1. Remove control valve assembly. Refer to AT-225. 2. Refer to "Component Inspection", AT-131.</p>	
	
SAT070J	
OK or NG	
OK	▶ GO TO 4.
NG	▶ Replace solenoid valve assembly.

DTC P0734 IMPROPER SHIFTING TO 4TH GEAR POSITION

Diagnostic Procedure (Cont'd)

GI
MA
EM
LC
EC
FE
CL
MT
AT
TF
PD
AX
SU
BR
ST
RS
BT
HA
SC
EL
IDX

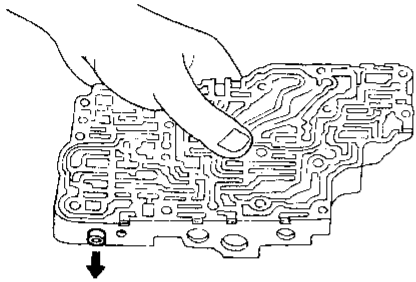
4	CHECK CONTROL VALVE
<ol style="list-style-type: none"> Disassemble control valve assembly. Refer to AT-250. Check to ensure that: <ul style="list-style-type: none"> Valve, sleeve and plug slide along valve bore under their own weight. Valve, sleeve and plug are free from burrs, dents and scratches. Control valve springs are free from damage, deformation and fatigue. Hydraulic line is free from obstacles. 	
	
SAT367H	
OK or NG	
OK	▶ GO TO 5.
NG	▶ Repair control valve.

5	CHECK SHIFT UP (D₃ TO D₄)
Does A/T shift from D ₃ to D ₄ at the specified speed?	
Yes or No	
Yes	▶ GO TO 6.
No	▶ Check control valve again. Repair or replace control valve assembly.

6	CHECK DTC
Perform Diagnostic Trouble Code (DTC) confirmation procedure, AT-125.	
OK or NG	
OK	▶ INSPECTION END AND GO TO 7.
NG	▶ <ul style="list-style-type: none"> GO TO 11. And check for proper lock-up.

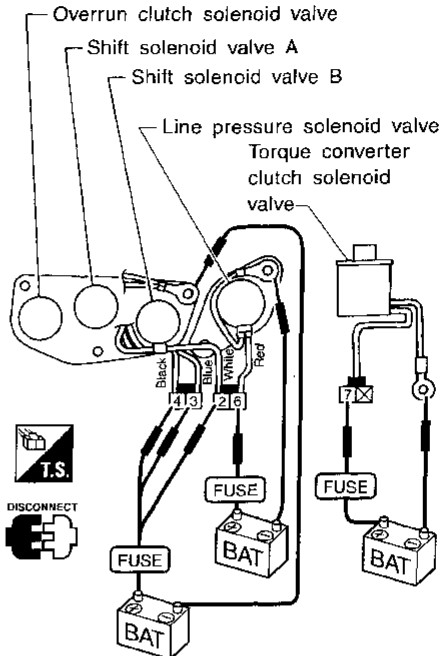
7	CHECK LINE PRESSURE SOLENOID VALVE
<ol style="list-style-type: none"> Remove control valve assembly. Refer to AT-225. Refer to "Component Inspection", AT-131. 	
	
SAT070J	
OK or NG	
OK	▶ GO TO 8.
NG	▶ Replace solenoid valve assembly.

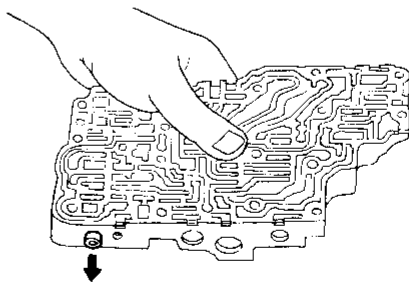
8	CHECK CONTROL VALVE
<ol style="list-style-type: none"> Disassemble control valve assembly. Refer to AT-250. Check line pressure circuit valves for sticking. <ul style="list-style-type: none"> Pressure regulator valve Pilot valve Pressure modifier valve 	
	
SAT367H	
OK or NG	
OK	▶ GO TO 9.
NG	▶ Repair control valve.

DTC P0734 IMPROPER SHIFTING TO 4TH GEAR POSITION

Diagnostic Procedure (Cont'd)

9	CHECK SHIFT UP (D₃ TO D₄)
Does A/T shift from D ₃ to D ₄ at the specified speed?	
OK or NG	
OK	▶ GO TO 10.
NG	▶ Check control valve again. Repair or replace control valve assembly.

10	CHECK DTC
Perform Diagnostic Trouble Code (DTC) confirmation procedure, AT-125.	
OK or NG	
OK	▶ INSPECTION END AND GO TO 11.
NG	▶ <ul style="list-style-type: none"> • GO TO 11. • And check for proper lock-up.

11	CHECK LOCK-UP
During "Cruise test -- Part 1", AT-64, Does A/T perform lock-up at the specified speed?	
Yes or No	
Yes	▶ Perform "Cruise test -- Part 1" again and return to the start point of this flow chart.
No	▶ GO TO 12.

12	CHECK TORQUE CONVERTER CLUTCH SOLENOID VALVE
1. Remove control valve assembly. Refer to AT-225. 2. Refer to "Component Inspection", AT-131.	
OK or NG	
OK	▶ GO TO 13.
NG	▶ Replace solenoid valve assembly.

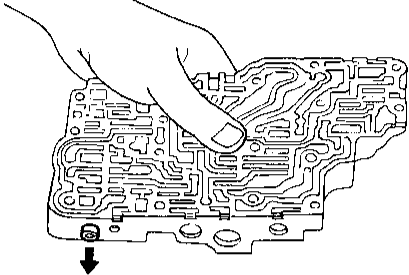
13	CHECK CONTROL VALVE
1. Disassemble control valve assembly. Refer to AT-250. 2. Check control valves for sticking. <ul style="list-style-type: none"> • Torque converter clutch control valve • Torque converter clutch relief valve 	
	
SAT367H	
OK or NG	
OK	▶ GO TO 14.
NG	▶ Repair control valve

14	CHECK LOCK-UP
Does A/T perform lock-up at the specified speed?	
Yes or No	
Yes	▶ GO TO 15.
No	▶ Check control valve again. Repair or replace control valve assembly.

15	CHECK DTC
Perform Diagnostic Trouble Code (DTC) confirmation procedure, AT-125.	
OK or NG	
OK	▶ INSPECTION END
NG	▶ Perform "Cruise test -- Part 1" again and return to the start point of this flow chart.

NAAT0050

NAAT0050S01

GI
MA
EM
LC
EC
FE
CL
MT
AT
TF
PD
AX
SU
BR
ST
RS
BT
HA
SC
EL
IDX

Component Inspection

SOLENOID VALVES

- For removal, refer to AT-225.

Resistance Check

- Check resistance between terminals (3, 2, 4, 6 or 7) and ground.

Solenoid valve	Terminal No.	Resistance (Approx.)
Shift solenoid valve A	3	20 - 40Ω
Shift solenoid valve B	2	
Overrun clutch solenoid valve	4	2.5 - 5Ω
Line pressure solenoid valve	6	
Torque converter clutch solenoid valve	7	10 - 20Ω

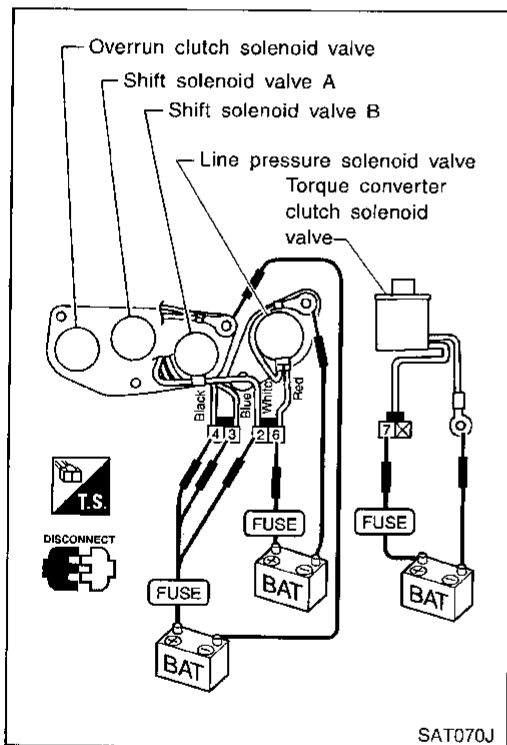
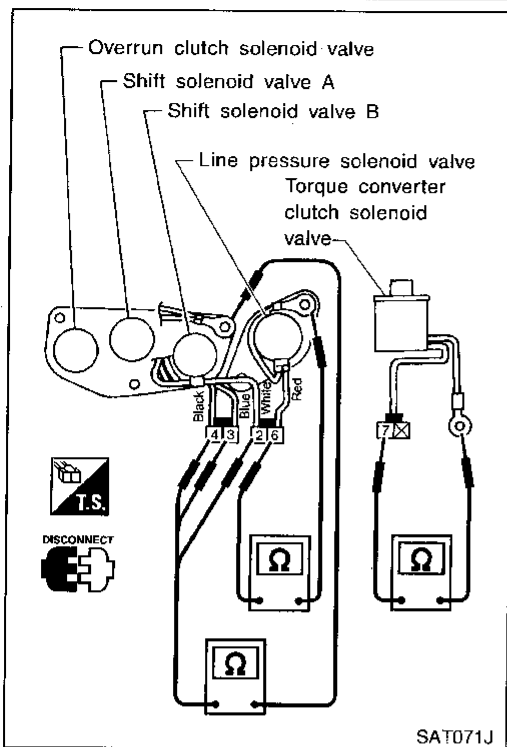

Operation Check

- Check solenoid valve by listening for its operating sound while applying battery voltage to the terminals (3, 2, 4, 6 or 7) and ground.

DTC P0740 TORQUE CONVERTER CLUTCH SOLENOID VALVE

Description

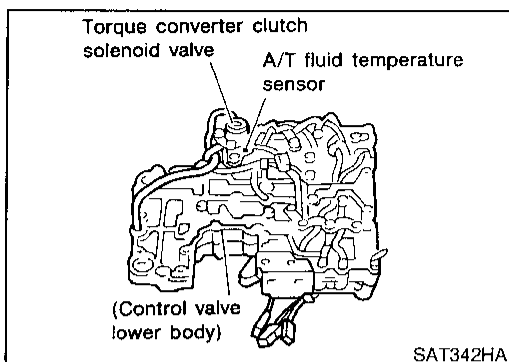

Description

The torque converter clutch solenoid valve is activated, with the gear in "D₄", by the TCM in response to signals sent from the vehicle speed and throttle position sensors. Lock-up piston operation will then be controlled.

Lock-up operation, however, is prohibited when A/T fluid temperature is too low.

When the accelerator pedal is depressed (less than 2/8) in lock-up condition, the engine speed should not change abruptly. If there is a big jump in engine speed, there is no lock-up.

CONSULT REFERENCE VALUE IN DATA MONITOR MODE

Remarks: Specification data are reference values.

Monitor item	Condition	Specification
Torque converter clutch solenoid valve duty	Lock-up "OFF"	Approximately 4%
	↓ Lock-up "ON"	↓ Approximately 94%

TCM TERMINALS AND REFERENCE VALUE

Remarks: Specification data are reference values.

Terminal No.	Wire color	Item	Condition	Judgement standard
5	G/OR	Torque converter clutch solenoid valve	 When A/T performs lock-up.	8 - 15V
			When A/T does not perform lock-up.	1V or less

ON BOARD DIAGNOSIS LOGIC

Diagnostic trouble code	Malfunction is detected when ...	Check item (Possible cause)
Ⓜ : TCC SOLENOID/CIRC Ⓢ : P0740 Ⓜ : MIL Code No. 1204	TCM detects an improper voltage drop when it tries to operate the solenoid valve.	<ul style="list-style-type: none"> • Harness or connectors (The solenoid circuit is open or shorted.) • T/C clutch solenoid valve

SELECT SYSTEM
ENGINE
A/T

SAT974H

SELECT DIAG MODE	<input type="checkbox"/>
SELF-DIAG RESULTS	
DATA MONITOR	
DTC WORK SUPPORT	
ECU PART NUMBER	

SAT906I

DIAGNOSTIC TROUBLE CODE (DTC) CONFIRMATION PROCEDURE

NAAT0051S01

NOTE:

If "DIAGNOSTIC TROUBLE CODE CONFIRMATION PROCEDURE" has been previously conducted, always turn ignition switch "OFF" and wait at least 5 seconds before conducting the next test.

After the repair, perform the following procedure to confirm the malfunction is eliminated.

Ⓢ With CONSULT

- 1) Turn ignition switch "ON".
- 2) Select "DATA MONITOR" mode for "ENGINE" with CONSULT and wait at least 1 second.

Ⓢ With GST

- 1) Turn ignition switch "ON".
- 2) Select "MODE 7" with GST.

Ⓢ No Tools

- 1) Turn ignition switch "ON".
- 2) Perform self-diagnosis for ECM.
Refer to EC section ["Malfunction Indicator Lamp (MIL)", "ON BOARD DIAGNOSTIC SYSTEM DESCRIPTION"].

GI

MA

EM

LC

EC

FE

GL

MT

AT

TF

PD

AX

SU

BR

ST

RS

BT

HA

SC

EL

IDX

DTC P0740 TORQUE CONVERTER CLUTCH SOLENOID VALVE

Wiring Diagram — AT — TCV

Wiring Diagram — AT — TCV

NAAT0194

AT-TCV-01

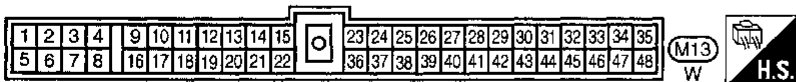
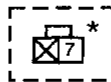
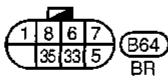
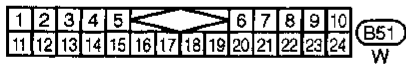
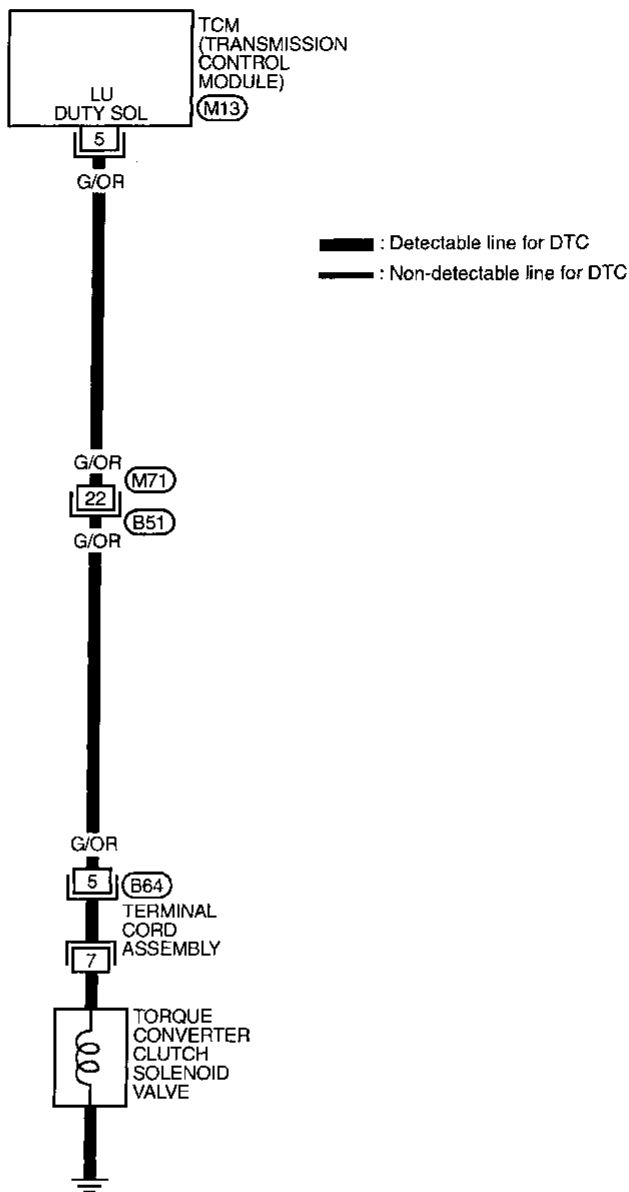

* : This connector is not shown in "HARNES LAYOUT" in EL section.

MAT562A

Diagnostic Procedure

1	CHECK GROUND CIRCUIT
<ol style="list-style-type: none"> Turn ignition switch to "OFF" position. Disconnect terminal cord assembly connector in engine compartment. Check resistance between terminal 5 and ground. 	
<p>Sub-harness connector (B64)</p> <p style="text-align: right;">SAT336I</p>	
<p>Is resistance approx. 10 - 20 Ω?</p>	
Yes	▶ GO TO 2.
No	<ol style="list-style-type: none"> Remove oil pan. Refer to AT-225. Check the following items: <ul style="list-style-type: none"> Torque converter clutch solenoid valve Refer to "Component Inspection", AT-136. Harness of terminal cord assembly for short or open

2	CHECK RESISTANCE
<ol style="list-style-type: none"> Turn ignition switch to "OFF" position. Disconnect TCM harness connector. Check resistance between terminal 5 and TCM harness connector terminal 5. 	
<p>Sub-harness connector (B64)</p> <p style="text-align: right;">SAT072J</p>	
<p>Is resistance approx. 0Ω?</p>	
Yes	▶ GO TO 3.
No	▶ Repair open circuit or short to ground or short to power in harness or connectors.

3	CHECK DTC
<p>Perform Diagnostic Trouble Code (DTC) confirmation procedure, AT-133.</p>	
<p>OK or NG</p>	
OK	▶ INSPECTION END
NG	<ol style="list-style-type: none"> Perform TCM input/output signal inspection. If NG, recheck TCM pin terminals for damage or loose connection with harness connector.

GI
MA
EM
LC
EC
FE
CL
MT
AT
TF
PD
AX
SU
BR
ST
RS
BT
HA
SC
EL
IDX

DTC P0740 TORQUE CONVERTER CLUTCH SOLENOID VALVE

Component Inspection

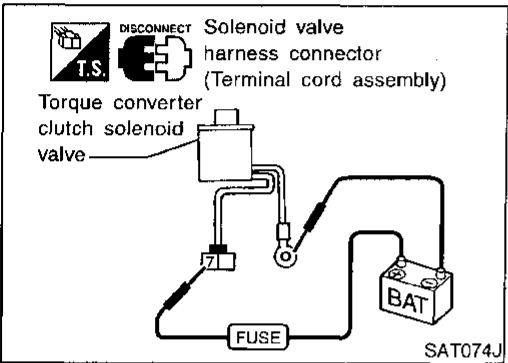
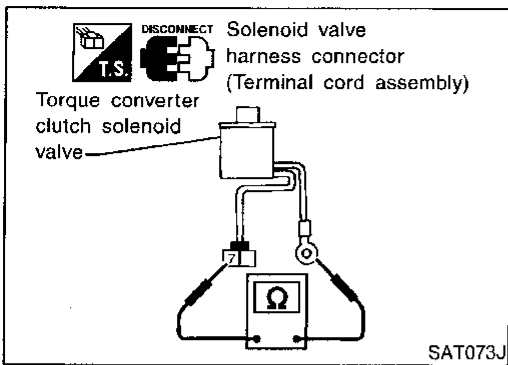

Component Inspection

TORQUE CONVERTER CLUTCH SOLENOID VALVE

NAAT0053

NAAT0053S01

- For removal, refer to AT-225.

Resistance Check

NAAT0053S0101

- Check resistance between terminal 7 and ground.

Solenoid valve	Terminal No.		Resistance (Approx.)
Torque converter clutch solenoid valve	7	Ground	10 - 20Ω

Operation Check

NAAT0053S0102

- Check solenoid valve by listening for its operating sound while applying battery voltage to the terminal 7 and ground.

DTC P0744 IMPROPER LOCK-UP OPERATION

Description

Description

- This is an OBD-II self-diagnostic item and not available in TCM self-diagnosis. NAAT0054
- This malfunction will not be detected while the O/D OFF indicator lamp is indicating another self-diagnosis malfunction. MA
- This malfunction is detected when the A/T does not shift into fourth gear position or the torque converter clutch does not lock up as instructed by the TCM. This is not caused by electrical malfunction (circuits open or shorted) but by mechanical malfunction such as control valve sticking, improper solenoid valve operation, malfunctioning oil pump or torque converter clutch, etc. EM
LC
EC

CONSULT REFERENCE VALUE IN DATA MONITOR MODE

NAAT0054S02







Remarks: Specification data are reference values.

Monitor item	Condition	Specification
Torque converter clutch solenoid valve duty	Lock-up "OFF"	Approximately 4%
	↓	↓
	Lock-up "ON"	Approximately 94%

TCM TERMINALS AND REFERENCE VALUE

NAAT0054S03

Remarks: Specification data are reference values.

Terminal No.	Wire color	Item	Condition	Judgement standard	
1	GY	Line pressure solenoid valve		When releasing accelerator pedal after warming up engine.	1.5 - 2.5V
				When depressing accelerator pedal fully after warming up engine.	0.5V or less
2	BR/Y	Line pressure solenoid valve (with dropping resistor)		When releasing accelerator pedal after warming up engine.	5 - 14V
				When depressing accelerator pedal fully after warming up engine.	0.5V or less
5	G/OR	Torque converter clutch solenoid valve		When A/T performs lock-up.	8 - 15V
				When A/T does not perform lock-up.	1V or less
6	L/W	Shift solenoid valve A		When shift solenoid valve A operates. (When driving in "D ₁ " or "D ₄ ".)	Battery voltage
				When shift solenoid valve A does not operate. (When driving in "D ₂ " or "D ₃ ".)	1V or less
7	L/R	Shift solenoid valve B		When shift solenoid valve B operates. (When driving in "D ₁ " or "D ₂ ".)	Battery voltage
				When shift solenoid valve B does not operate. (When driving in "D ₃ " or "D ₄ ".)	1V or less
8	L/B	Overrun clutch solenoid valve		When overrun clutch solenoid valve operates.	Battery voltage
				When overrun clutch solenoid valve does not operate.	1V or less

DTC P0744 IMPROPER LOCK-UP OPERATION

Description (Cont'd)

ON BOARD DIAGNOSIS LOGIC

NAA70054S04

This diagnosis monitors actual gear position by checking the torque converter slip ratio calculated by TCM as follows:

Torque converter slip ratio = $A \times C/B$

A: Output shaft revolution signal from revolution sensor

B: Engine speed signal from ECM



C: Gear ratio determined as gear position which TCM supposes

If the actual gear position is much lower than the position (4th) supposed by TCM, the slip ratio will be much less than normal. In case the ratio does not reach the specified value, TCM judges this diagnosis malfunction.

This malfunction will be caused when shift solenoid valve B is stuck closed.

Gear position supposed by TCM	1	2	3	4
In case of gear position with no malfunctions	1	2	3	4
In case of gear position with shift solenoid valve B stuck closed	1	2	2	1*

*: P0744 is detected.

Diagnostic trouble code	Malfunction is detected when ...	Check item (Possible cause)
 : A/T TCC S/V FNCTN	A/T cannot perform lock-up even if electrical circuit is good.	<ul style="list-style-type: none"> • Torque converter clutch solenoid valve • Each clutch • Hydraulic control circuit
 : P0744		
 : MIL Code No. 1107		

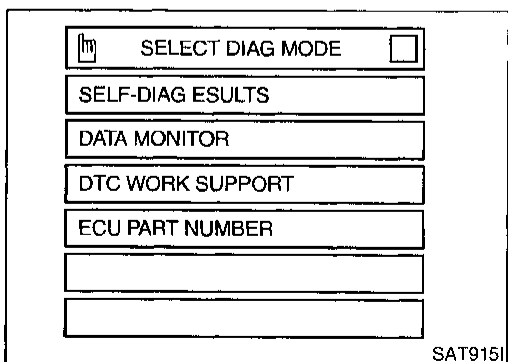
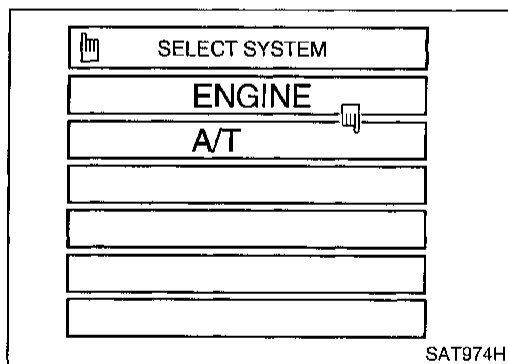

DIAGNOSTIC TROUBLE CODE (DTC) CONFIRMATION PROCEDURE

NAA70054S01

CAUTION:

Always drive vehicle at a safe speed.

NOTE:

If "DIAGNOSTIC TROUBLE CODE CONFIRMATION PROCEDURE" has been previously conducted, always turn ignition switch "OFF" and wait at least 5 seconds before conducting the next test.

After the repair, perform the following procedure to confirm the malfunction is eliminated.

With CONSULT

- 1) Start engine and select "DATA MONITOR" mode for "A/T" with CONSULT.
- 2) Make sure that output voltage of A/T fluid temperature sensor is within the range below.

FLUID TEMP SEN: 0.4 - 1.5V

If out of range, drive the vehicle to decrease the voltage (warm up the fluid) or stop engine to increase the voltage (cool down the fluid).

- 3) Select "TCC S/V FNCTN P0744" of "DTC WORK SUPPORT" mode for "A/T" with CONSULT and touch "START".

DTC P0744 IMPROPER LOCK-UP OPERATION

Description (Cont'd)

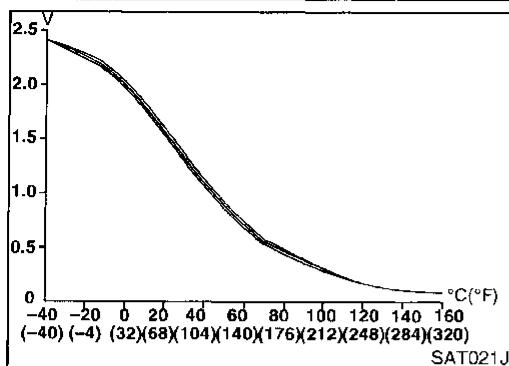

- 4) Accelerate vehicle to more than 80 km/h (50 MPH) and maintain the following condition continuously until "TESTING" has turned to "COMPLETED". (It will take approximately 30 seconds after "TESTING" shows.)

THROTTLE POSI: 1/8 - 2/8 (at all times during step 4)

Selector lever: D position (OD "ON")

TCC S/V DUTY: More than 94%

VHCL/S SE-A/T: Constant speed of more than 80 km/h (50 MPH)

- Check that "GEAR" shows "4".
 - For shift schedule, refer to SDS, AT-307.
 - If "TESTING" does not appear on CONSULT for a long time, select "SELF-DIAG RESULTS". In case a 1st trip DTC other than P0744 is shown, refer to applicable "TROUBLE DIAGNOSIS FOR DTC".
- 5) Make sure that "OK" is displayed. (If "NG" is displayed, refer to "DIAGNOSTIC PROCEDURE".)
Refer to "DIAGNOSTIC PROCEDURE", AT-141.
Refer to shift schedule, AT-307.

With GST

- 1) Start engine and warm up ATF.
- 2) Start vehicle with selector lever in "D" (OD "ON") position and throttle opening 1/8 - 2/8. Check that vehicle runs through gear shift of D₁ → D₂ → D₃ → D₄ → D₄ lock-up, in accordance with shift schedule. Refer to shift schedule, AT-307.
- 3) Select "MODE 7" with GST.

No Tools

- 1) Start engine and warm up ATF.
- 2) Start vehicle with selector lever in "D" (OD "ON") position and throttle opening 1/8 - 2/8. Check that vehicle runs through gear shift of D₁ → D₂ → D₃ → D₄ → D₄ lock-up, in accordance with shift schedule. Refer to shift schedule, AT-307.
- 3) Perform self-diagnosis for ECM.
Refer to EC section ["Malfunction Indicator Lamp (MIL)", "ON BOARD DIAGNOSTIC SYSTEM DESCRIPTION"].



DTC P0744 IMPROPER LOCK-UP OPERATION

Wiring Diagram — AT — TCCSIG

Wiring Diagram — AT — TCCSIG

NAAT0196

AT-TCCSIG-01

 : Detectable line for DTC
 : Non-detectable line for DTC

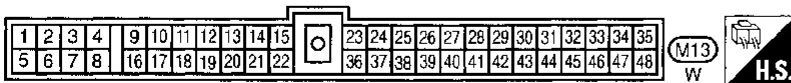
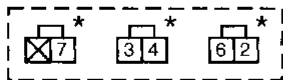
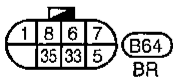
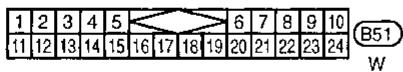
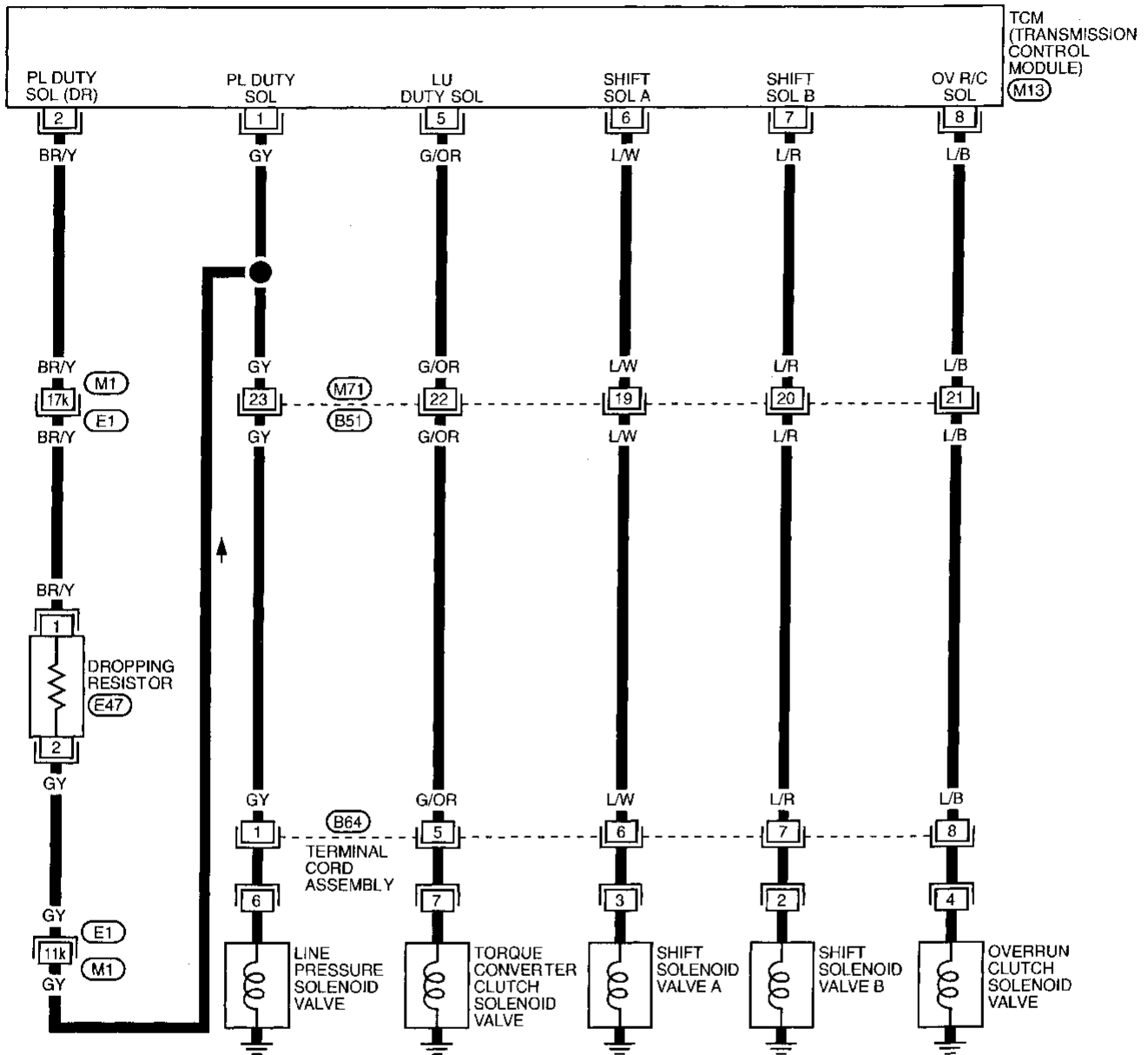

Refer to last page (Foldout page).

M1, E1

*: This connector is not shown in "HARNESS LAYOUT" in EL section.

MAT563A

Diagnostic Procedure

=NAAT0055

1	CHECK SHIFT UP (D₃ TO D₄)
During "Cruise test – Part 1", AT-64. Does A/T shift from D ₃ to D ₄ at the specified speed?	
<p>D₃ → D₄ Accelerator pedal Halfway</p>	
SAT988H	
Yes or No	
Yes	► <ul style="list-style-type: none"> GO TO 11. And check for proper lock-up.
No	► GO TO 2.

2	CHECK LINE PRESSURE
Perform line pressure test. Refer to AT-57.	
OK or NG	
OK	► GO TO 3.
NG	► GO TO 7.

3	CHECK SOLENOID VALVES
1. Remove control valve assembly. Refer to AT-225. 2. Check solenoid valve assembly operation. Refer to AT-144.	
SAT070J	
OK or NG	
OK	► GO TO 4.
NG	► Replace solenoid valve assembly.

GI
MA
EM
LC
EC
FE
CL
MT
AT
TF
PD
AX
SU
BR
ST
RS
BT
HA
SC
EL
IDX

DTC P0744 IMPROPER LOCK-UP OPERATION

Diagnostic Procedure (Cont'd)

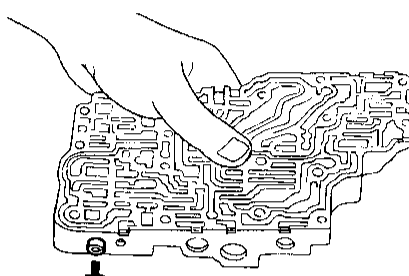
4	CHECK CONTROL VALVE
<ol style="list-style-type: none"> Disassemble control valve assembly. Refer to AT-250. Check to ensure that: <ul style="list-style-type: none"> Valve, sleeve and plug slide along valve bore under their own weight. Valve, sleeve and plug are free from burrs, dents and scratches. Control valve springs are free from damage, deformation and fatigue. Hydraulic line is free from obstacles. 	
	
SAT367H	
OK or NG	
OK	▶ GO TO 5.
NG	▶ Repair control valve.

5	CHECK SHIFT UP (D₃ TO D₄)
Does A/T shift from D ₃ to D ₄ at the specified speed?	
Yes or No	
Yes	▶ GO TO 6.
No	▶ Check control valve again. Repair or replace control valve assembly.

6	CHECK DTC
Perform Diagnostic Trouble Code (DTC) confirmation procedure, AT-138.	
OK or NG	
OK	▶ INSPECTION END
NG	▶ <ul style="list-style-type: none"> GO TO 11. And check for proper lock-up.

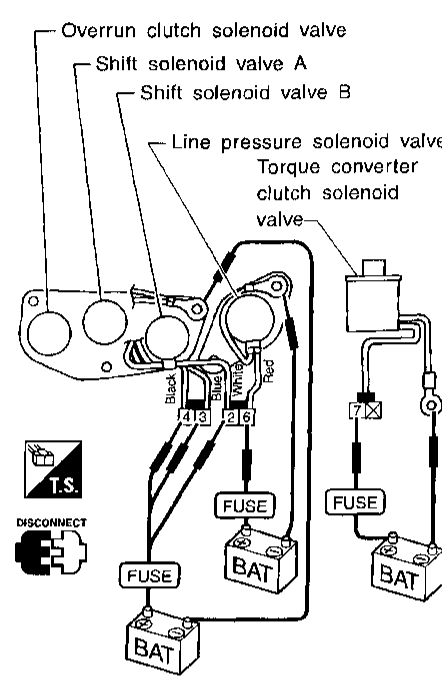
7	CHECK LINE PRESSURE SOLENOID VALVE
<ol style="list-style-type: none"> Remove control valve assembly. Refer to AT-225. Check line pressure solenoid valve operation. Refer to AT-144. 	
	
SAT070J	
OK or NG	
OK	▶ GO TO 8.
NG	▶ Replace solenoid valve assembly.

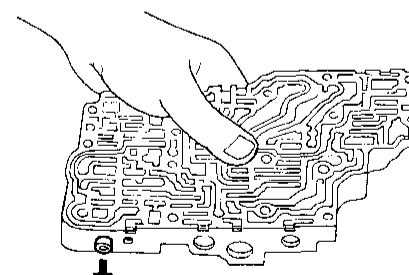
8	CHECK CONTROL VALVE
<ol style="list-style-type: none"> Disassemble control valve assembly. Refer to AT-250. Check line pressure circuit valves for sticking. <ul style="list-style-type: none"> Pressure regulator valve Pilot valve Pressure modifier valve 	
	
SAT367H	
OK or NG	
OK	▶ GO TO 9.
NG	▶ Repair control valve.

DTC P0744 IMPROPER LOCK-UP OPERATION

Diagnostic Procedure (Cont'd)

9	CHECK SHIFT UP (D₃ TO D₄)
Does A/T shift from D ₃ to D ₄ at the specified speed?	
Yes or No	
Yes	▶ GO TO 10.
No	▶ Check control valve again. Repair or replace control valve assembly.

10	CHECK DTC
Perform Diagnostic Trouble Code (DTC) confirmation procedure, AT-138.	
OK or NG	
OK	▶ INSPECTION END
NG	▶ <ul style="list-style-type: none"> • GO TO 11. • And check for proper lock-up.

11	CHECK LOCK-UP CONDITION
During "Cruise test – Part 1", AT-64, Does A/T perform lock-up at the specified speed?	
Yes or No	
Yes	▶ Perform "Cruise test – Part 1" again and return to the start point of this flow chart.
No	▶ GO TO 12.

12	CHECK TORQUE CONVERTER CLUTCH SOLENOID VALVE
<ol style="list-style-type: none"> 1. Remove control valve assembly. Refer to AT-225. 2. Check torque converter clutch solenoid valve operation. Refer to AT-144. 	
OK or NG	
OK	▶ GO TO 13.
NG	▶ Replace solenoid valve assembly.

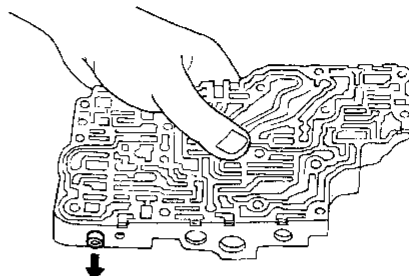
13	CHECK CONTROL VALVE
<ol style="list-style-type: none"> 1. Disassemble control valve assembly. Refer to AT-250. 2. Check control valves for sticking. <ul style="list-style-type: none"> • Torque converter clutch control valve • Torque converter clutch relief valve 	
	
SAT367H	
OK or NG	
OK	▶ GO TO 14.
NG	▶ Repair control valve

14	CHECK LOCK-UP CONDITION
Does A/T perform lock-up at the specified speed?	
Yes or No	
Yes	▶ GO TO 15.
No	▶ Check control valve again. Repair or replace control valve assembly.

15	CHECK DTC
Perform Diagnostic Trouble Code (DTC) confirmation procedure, AT-138.	
OK or NG	
OK	▶ INSPECTION END
NG	▶ Perform "Cruise test — Part 1" again and return to the start point of this flow chart.

GI
MA
EM
LC
EC
FE
CL
MT
AT
TF
PD
AX
SU
BR
ST
RS
BT
HA
SC
EL
IDX

DTC P0744 IMPROPER LOCK-UP OPERATION

Component Inspection

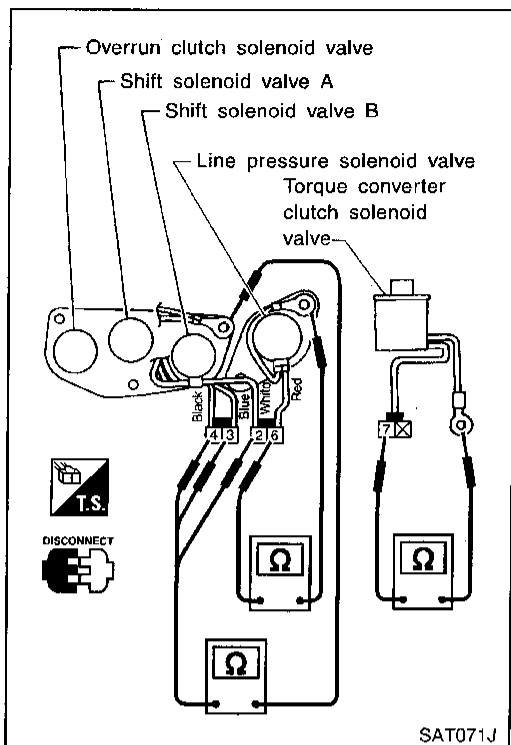

Component Inspection

SOLENOID VALVES

NAAT0056

NAAT0056S01

- For removal, refer to AT-225.

Resistance Check

NAAT0056S0101

- Check resistance between terminals (3, 2, 4, 6 or 7) and ground.

Solenoid valve	Terminal No.	Resistance (Approx.)
Shift solenoid valve A	3	20 - 40Ω
Shift solenoid valve B	2	
Overrun clutch solenoid valve	4	2.5 - 5Ω
Line pressure solenoid valve	6	
Torque converter clutch solenoid valve	7	10 - 20Ω

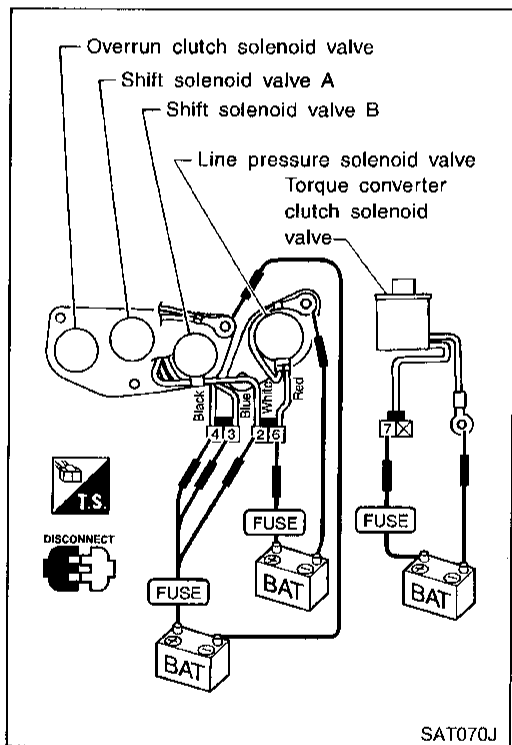

Operation Check

NAAT0056S0102

- Check solenoid valve by listening for its operating sound while applying battery voltage to the terminals (3, 2, 4, 6 or 7) and ground.

DTC P0745 LINE PRESSURE SOLENOID VALVE

Description

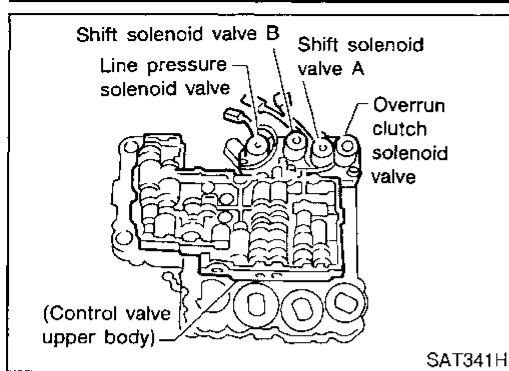

Description

The line pressure solenoid valve regulates the oil pump discharge pressure to suit the driving condition in response to a signal sent from the TCM.

The line pressure duty cycle value is not consistent when the closed throttle position switch is "ON". To confirm the line pressure duty cycle at low pressure, the accelerator (throttle) should be open until the closed throttle position switch is "OFF".

CONSULT REFERENCE VALUE IN DATA MONITOR MODE

Remarks: Specification data are reference values.

Monitor item	Condition	Specification
Line pressure solenoid valve duty	Small throttle opening (Low line pressure)	Approximately 24%
	Large throttle opening (High line pressure)	Approximately 95%

NOTE:

The line pressure duty cycle value is not consistent when the closed throttle position switch is "ON". To confirm the line pressure duty cycle at low pressure, the accelerator (throttle) should be open until the closed throttle position switch is "OFF".

TCM TERMINALS AND REFERENCE VALUE

Remarks: Specification data are reference values.

Terminal No.	Wire color	Item	Condition	Judgement standard
1	GY	Line pressure solenoid valve	When releasing accelerator pedal after warming up engine.	1.5 - 2.5V
			When depressing accelerator pedal fully after warming up engine.	0.5V or less
2	BR/Y	Line pressure solenoid valve (with dropping resistor)	When releasing accelerator pedal after warming up engine.	5 - 14V
			When depressing accelerator pedal fully after warming up engine.	0.5V or less

ON BOARD DIAGNOSIS LOGIC

Diagnostic trouble code	Malfunction is detected when ...	Check item (Possible cause)
P : LINE PRESSURE SV P0745 MIL Code No. 1205	TCM detects an improper voltage drop when it tries to operate the solenoid valve.	<ul style="list-style-type: none"> Harness or connectors (The solenoid circuit is open or shorted.) Line pressure solenoid valve

DTC P0745 LINE PRESSURE SOLENOID VALVE

Description (Cont'd)

Diagram of CONSULT screen showing the "SELECT SYSTEM" menu. The "ENGINE" option is selected. The screen is labeled SEF895K.

Diagram of CONSULT screen showing the "SELECT DIAG MODE" menu. The "DTC CONFIRMATION" option is selected. The screen is labeled SAT9111.

DIAGNOSTIC TROUBLE CODE (DTC) CONFIRMATION PROCEDURE

NAAT0057S01

NOTE:

If "DIAGNOSTIC TROUBLE CODE CONFIRMATION PROCEDURE" has been previously conducted, always turn ignition switch "OFF" and wait at least 5 seconds before conducting the next test.

After the repair, perform the following procedure to confirm the malfunction is eliminated.

④ With CONSULT

- 1) Turn ignition switch "ON" and select "DATA MONITOR" mode for "ENGINE" with CONSULT.
- 2) Depress accelerator pedal completely and wait at least 1 second.

④ With GST

- 1) Turn ignition switch "ON".
- 2) Depress accelerator pedal completely and wait at least 1 second.
- 3) Select "MODE 7" with GST.

④ No Tools

- 1) Turn ignition switch "ON".
- 2) Depress accelerator pedal completely and wait at least 1 second.
- 3) Perform self-diagnosis for ECM.
Refer to EC section ["Malfunction Indicator Lamp (MIL)", "ON BOARD DIAGNOSTIC SYSTEM DESCRIPTION"].

DTC P0745 LINE PRESSURE SOLENOID VALVE

Wiring Diagram — AT — LPSV

Wiring Diagram — AT — LPSV

NAAT0196

AT-LPSV-01

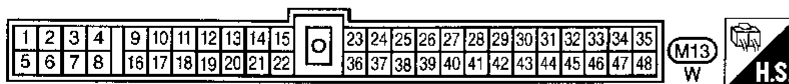
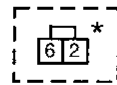
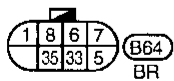
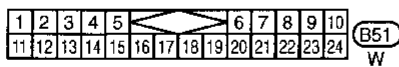
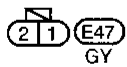
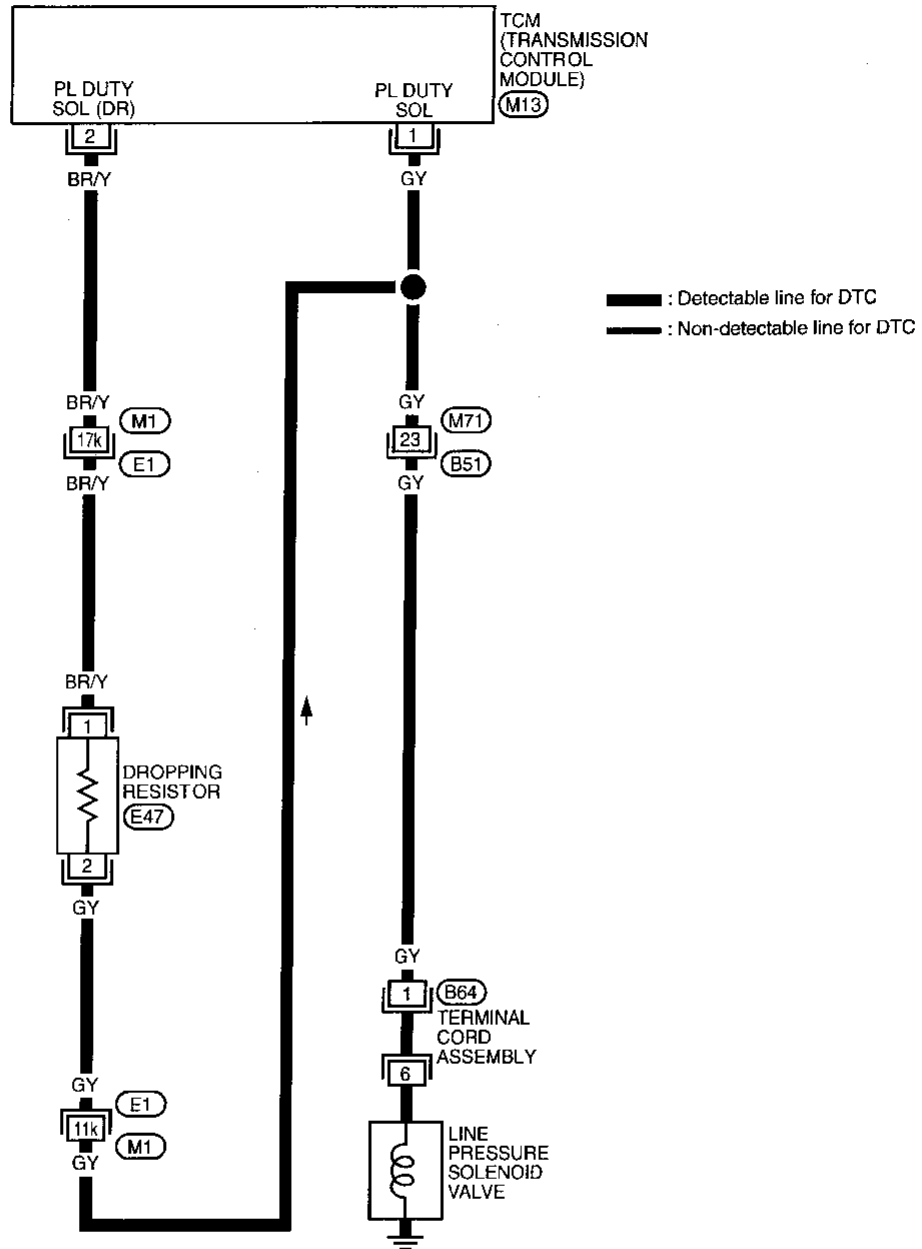

* : This connector is not shown in "HARNESS LAYOUT" in EL section.

Refer to last page (Foldout page).

(M1), (E1)

GI

MA

EM

LC

EC

FE

CL

MT

AT

TF

PD

AX

SU

BR

ST

RS

BT

HA

SC

EL

IDX

MAT564A

DTC P0745 LINE PRESSURE SOLENOID VALVE

Diagnostic Procedure

Diagnostic Procedure

NAAT0059

1	CHECK GROUND CIRCUIT
<ol style="list-style-type: none"> Turn ignition switch to "OFF" position. Disconnect terminal cord assembly connector in engine compartment. Check resistance between terminal 1 and ground. 	
<p>Sub-harness connector (B64)</p> <p style="text-align: right;">SAT192IA</p>	
<p>Is resistance approx. 2.5 - 5Ω?</p>	
Yes	▶ GO TO 2.
No	▶ <ol style="list-style-type: none"> Remove control valve assembly. Refer to AT-225. Check the following items: <ul style="list-style-type: none"> Line pressure solenoid valve Refer to "Component Inspection", AT-149. Harness of terminal cord assembly for short or open

2	CHECK POWER SOURCE CIRCUIT
<ol style="list-style-type: none"> Turn ignition switch to "OFF" position. Disconnect TCM harness connector. Check resistance between terminal 1 and TCM harness connector terminal 2. 	
<p>Sub-harness connector (B64)</p> <p style="text-align: right;">SAT075J</p>	
<p>Is resistance approx. 11.2 - 12.8Ω?</p>	
Yes	▶ GO TO 3.
No	▶ Check the following items: <ul style="list-style-type: none"> Dropping resistor Refer to "Component Inspection", AT-149. Harness for short or open between TCM terminal 2 and terminal cord assembly (Main harness)

DTC P0745 LINE PRESSURE SOLENOID VALVE

Diagnostic Procedure (Cont'd)

3	CHECK POWER SOURCE CIRCUIT
<p>1. Turn ignition switch to "OFF" position. 2. Check resistance between terminal 1 and TCM harness connector terminal 1.</p>	
SAT075J	
Is resistance approx. 0Ω?	
Yes	▶ GO TO 4.
No	▶ Repair or replace harness between TCM terminal 1 and terminal cord assembly.

4	CHECK DTC
<p>Perform Diagnostic Trouble Code (DTC) confirmation procedure, AT-146.</p>	
OK or NG	
OK	▶ INSPECTION END
NG	▶ <ol style="list-style-type: none"> 1. Perform TCM input/output signal inspection. 2. If NG, recheck TCM pin terminals for damage or loose connection with harness connector.

		<p>Solenoid valve harness connector (Terminal cord assembly)</p> <p>Line pressure solenoid valve</p>
SAT657I		

Component Inspection

LINE PRESSURE SOLENOID VALVE

NAAT0059
NAAT0059S01

- For removal, refer to AT-225.

Resistance Check

NAAT0059S0101

- Check resistance between terminal 6 and ground.

Solenoid valve	Terminal No.		Resistance (Approx.)
Line pressure solenoid valve	6	Ground	2.5 - 5Ω

		<p>Solenoid valve harness connector (Terminal cord assembly)</p> <p>Line pressure solenoid valve</p>
SAT658I		

Operation Check

NAAT0059S0102

- Check solenoid valve by listening for its operating sound while applying battery voltage to the terminal 6 and ground.

GI
MA
EM
LC
EC
FE
CL
MT
AT
TF
PD
AX
SU
BR
ST
RS
BT
HA
SC
EL
IDX

DTC P0745 LINE PRESSURE SOLENOID VALVE

Component Inspection (Cont'd)

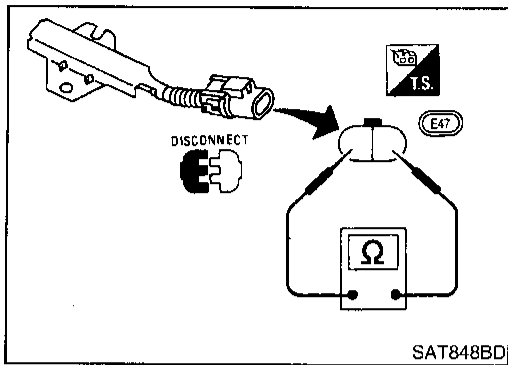

DROPPING RESISTOR

- Check resistance between two terminals.
Resistance: 11.2 - 12.8 Ω

NAAT0059S02

DTC P0750 SHIFT SOLENOID VALVE A

Description

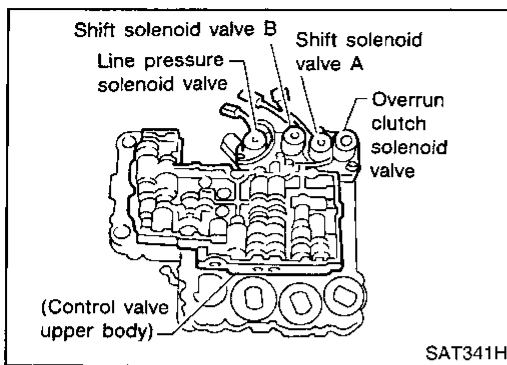

Description

Shift solenoid valves A and B are turned "ON" or "OFF" by the TCM in response to signals sent from the inhibitor switch, vehicle speed and throttle position sensors. Gears will then be shifted to the optimum position.

Gear position	1	2	3	4
Shift solenoid valve A	ON (Closed)	OFF (Open)	OFF (Open)	ON (Closed)
Shift solenoid valve B	ON (Closed)	ON (Closed)	OFF (Open)	OFF (Open)

TCM TERMINALS AND REFERENCE VALUE

Remarks: Specification data are reference values.

Terminal No.	Wire color	Item	Condition	Judgement standard
6	L/W	Shift solenoid valve A	 When shift solenoid valve A operates. (When driving in "D ₁ " or "D ₄ ".)	Battery voltage
			When shift solenoid valve A does not operate. (When driving in "D ₂ " or "D ₃ ".)	1V or less

ON BOARD DIAGNOSIS LOGIC

Diagnostic trouble code	Malfunction is detected when ...	Check item (Possible cause)
P ₀₇₅₀ : SFT SOL A/CIRC P ₀₇₅₀ : P0750 P ₁₁₀₈ : MIL Code No. 1108	TCM detects an improper voltage drop when it tries to operate the solenoid valve.	<ul style="list-style-type: none"> Harness or connectors (The solenoid circuit is open or shorted.) Shift solenoid valve A

DTC P0750 SHIFT SOLENOID VALVE A

Description (Cont'd)

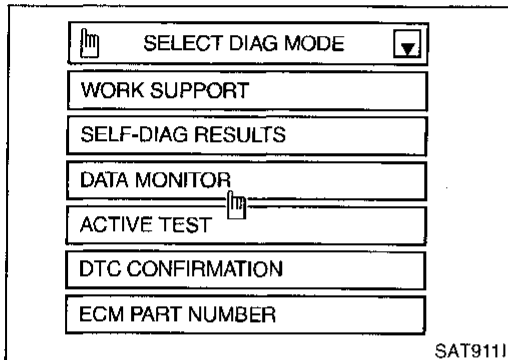
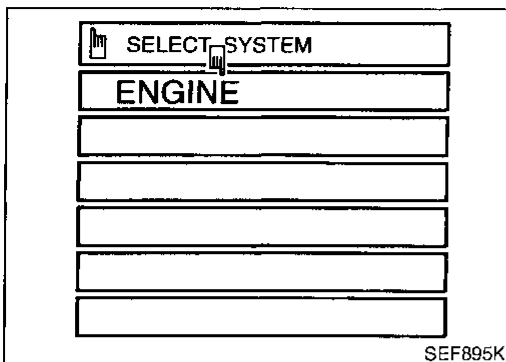

DIAGNOSTIC TROUBLE CODE (DTC) CONFIRMATION PROCEDURE

NAAT0060501

CAUTION:

Always drive vehicle at a safe speed.

NOTE:

If "DIAGNOSTIC TROUBLE CODE CONFIRMATION PROCEDURE" has been previously conducted, always turn ignition switch "OFF" and wait at least 5 seconds before conducting the next test.

After the repair, perform the following procedure to confirm the malfunction is eliminated.

With CONSULT

- 1) Turn ignition switch "ON" and select "DATA MONITOR" mode for "ENGINE" with CONSULT.
- 2) Start engine.
- 3) Drive vehicle in "D" position and allow the transmission to shift "1" → "2" ("GEAR").

With GST

- 1) Start engine.
- 2) Drive vehicle in D₁→D₂ position.
- 3) Select "MODE 7" with GST.

No Tools

- 1) Start engine.
- 2) Drive vehicle in D₁→D₂ position.
- 3) Perform self-diagnosis for ECM.

Refer to EC section ["Malfunction Indicator Lamp (MIL)", "ON BOARD DIAGNOSTIC SYSTEM DESCRIPTION"].

DTC P0750 SHIFT SOLENOID VALVE A

Wiring Diagram — AT — SSV/A

Wiring Diagram — AT — SSV/A

NAAT0197

AT-SSV/A-01

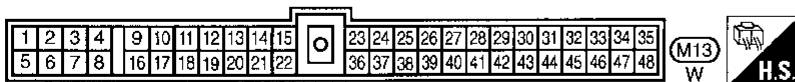
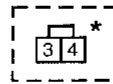
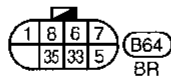
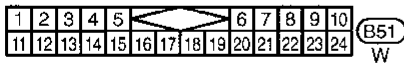
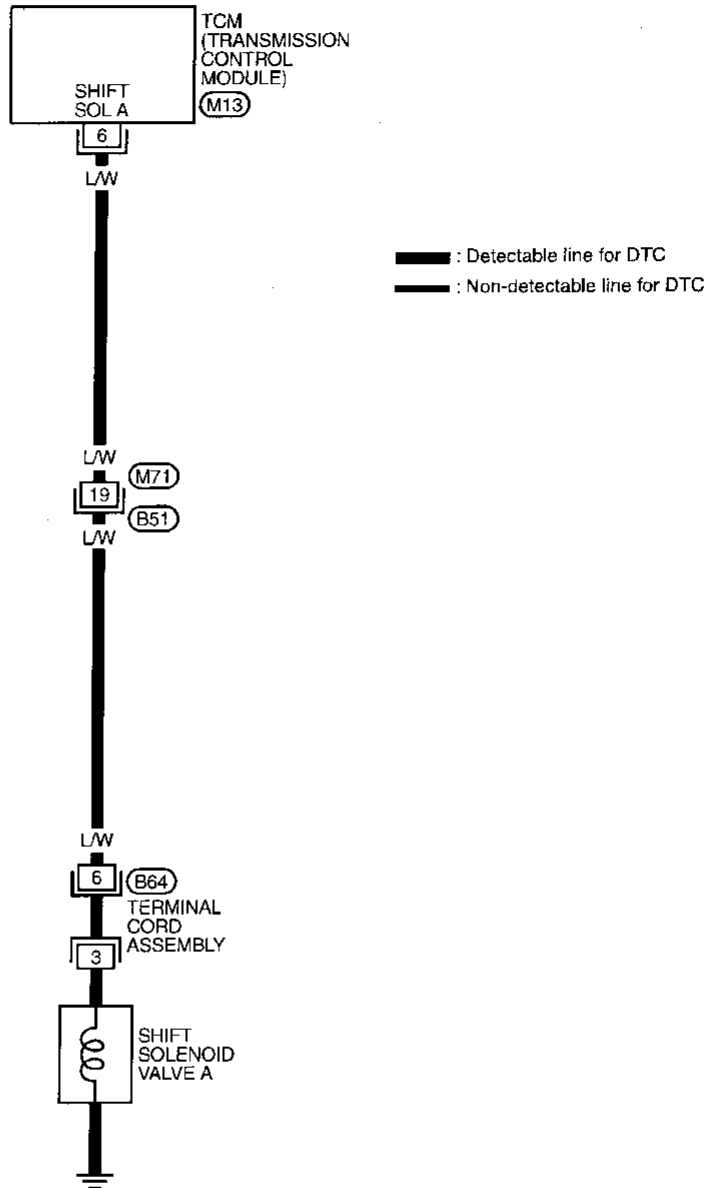

* : This connector is not shown in "HARNESS LAYOUT" in EL section.

MAT565A

DTC P0750 SHIFT SOLENOID VALVE A

Diagnostic Procedure

Diagnostic Procedure

NAAT0061

1 CHECK GROUND CIRCUIT	
<ol style="list-style-type: none"> Turn ignition switch to "OFF" position. Disconnect terminal cord assembly connector in engine compartment. Check resistance between terminal 6 and ground. 	
<p>Sub-harness connector (B64)</p> <p style="text-align: right;">SAT330I</p>	
<p>Is resistance approx. 20 - 40Ω?</p>	
Yes	▶ GO TO 2.
No	▶ <ol style="list-style-type: none"> Remove control valve assembly. Refer to AT-225. Check the following items: <ul style="list-style-type: none"> Shift solenoid valve A Refer to "Component Inspection", AT-155. Harness of terminal cord assembly for short or open

2 CHECK POWER SOURCE CIRCUIT	
<ol style="list-style-type: none"> Turn ignition switch to "OFF" position. Disconnect TCM harness connector. Check resistance between terminal 6 and TCM harness connector terminal 6. 	
<p>Sub-harness connector (B64)</p> <p style="text-align: right;">SAT076J</p>	
<p>If OK, check harness for short to ground and short to power.</p> <p>Is resistance approx. 0Ω?</p>	
Yes	▶ GO TO 3.
No	▶ Repair open circuit or short to ground or short to power in harness or connectors.

3 CHECK DTC	
Perform Diagnostic Trouble Code (DTC) confirmation procedure, AT-152.	
<p>OK or NG</p>	
OK	▶ INSPECTION END
NG	▶ <ol style="list-style-type: none"> Perform TCM input/output signal inspection. If NG, recheck TCM pin terminals for damage or loose connection with harness connector.

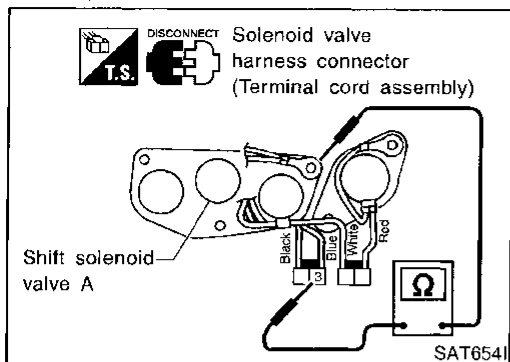

Component Inspection SHIFT SOLENOID VALVE A

NAAT0062

NAAT0062S01

- For removal, refer to AT-225.

Resistance Check

NAAT0062S0101

- Check resistance between terminal 3 and ground.

Solenoid valve	Terminal No.		Resistance (Approx.)
Shift solenoid valve A	3	Ground	20 - 40Ω

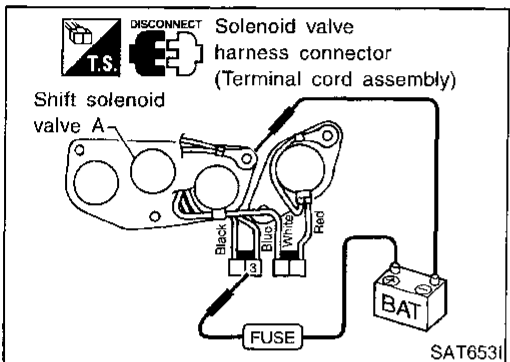

Operation Check

NAAT0062S0102

- Check solenoid valve by listening for its operating sound while applying battery voltage to the terminal 3 and ground.

GI
MA
EM
LC
EC
FE
CL
MT
AT
TF
PD
AX
SU
BR
ST
RS
BT
HA
SC
EL
IDX

DTC P0755 SHIFT SOLENOID VALVE B

Description

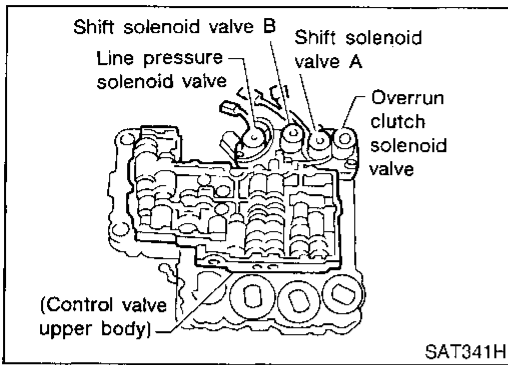

Description

Shift solenoid valves A and B are turned "ON" or "OFF" by the TCM ^{NAAT0063} in response to signals sent from the inhibitor switch, vehicle speed and throttle position sensors. Gears will then be shifted to the optimum position.

Gear position	1	2	3	4
Shift solenoid valve A	ON (Closed)	OFF (Open)	OFF (Open)	ON (Closed)
Shift solenoid valve B	ON (Closed)	ON (Closed)	OFF (Open)	OFF (Open)

TCM TERMINALS AND REFERENCE VALUE

Remarks: Specification data are reference values.

NAAT0063S02

Terminal No.	Wire color	Item	Condition	Judgement standard
7	L/R	Shift solenoid valve B	 When shift solenoid valve B operates. (When driving in "D ₁ " or "D ₂ ".)	Battery voltage
			When shift solenoid valve B does not operate. (When driving in "D ₃ " or "D ₄ ".)	1V or less

ON BOARD DIAGNOSIS LOGIC

NAAT0063S03

Diagnostic trouble code	Malfunction is detected when ...	Check item (Possible cause)
Ⓜ : SHIFT SOL B/CIRC Ⓜ : P0755 Ⓜ : MIL Code No. 1201	TCM detects an improper voltage drop when it tries to operate the solenoid valve.	<ul style="list-style-type: none"> • Harness or connectors (The solenoid circuit is open or shorted.) • Shift solenoid valve B

SELECT SYSTEM
ENGINE

SEF895K

SELECT DIAG MODE
WORK SUPPORT
SELF-DIAG RESULTS
DATA MONITOR
ACTIVE TEST
DTC CONFIRMATION
ECM PART NUMBER

SAT911I

DIAGNOSTIC TROUBLE CODE (DTC) CONFIRMATION PROCEDURE

NAAT0063S01

CAUTION:

Always drive vehicle at a safe speed.

NOTE:

If "DIAGNOSTIC TROUBLE CODE CONFIRMATION PROCEDURE" has been previously conducted, always turn ignition switch "OFF" and wait at least 5 seconds before conducting the next test.

After the repair, perform the following procedure to confirm the malfunction is eliminated.

Ⓟ With CONSULT

- 1) Turn ignition switch "ON" and select "DATA MONITOR" mode for "ENGINE" with CONSULT.
- 2) Drive vehicle in "D" position and allow the transmission to shift 1 → 2 → 3 ("GEAR").

Ⓞ With GST

- 1) Start engine.
- 2) Drive vehicle in D₁ → D₂ → D₃ position.
- 3) Select "MODE 7" with GST.

Ⓞ No Tools

- 1) Start engine.
- 2) Drive vehicle in D₁ → D₂ → D₃ position.
- 3) Perform self-diagnosis for ECM.

Refer to EC section ["Malfunction Indicator Lamp (MIL)", "ON BOARD DIAGNOSTIC SYSTEM DESCRIPTION"].

GI
MA
EM
LC
EC
FE
GL
MT
AT
TF
PD
AX
SU
BR
ST
RS
BT
HA
SC
EL
IDX

DTC P0755 SHIFT SOLENOID VALVE B

Wiring Diagram — AT — SSV/B

Wiring Diagram — AT — SSV/B

NAAT0198

AT-SSV/B-01

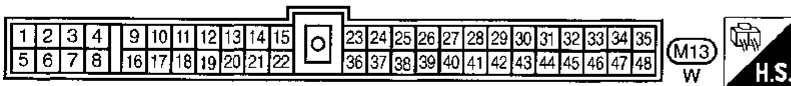
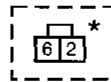
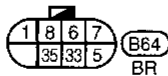
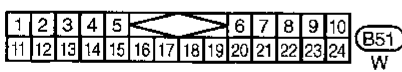
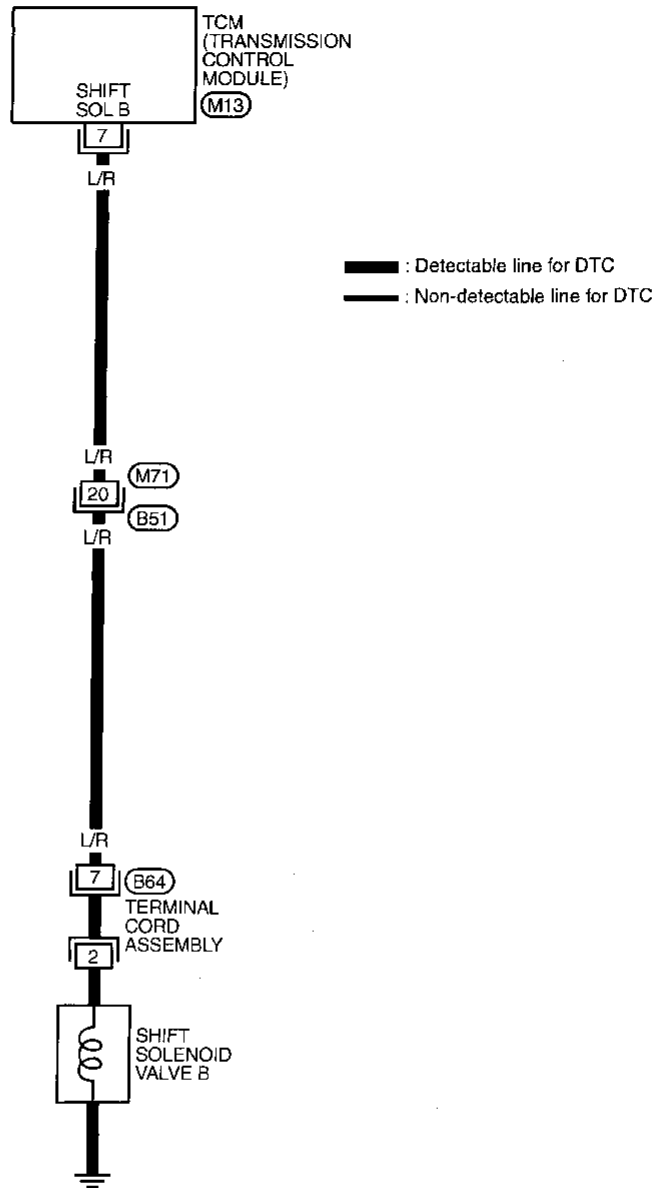

* : This connector is not shown in "HARNESS LAYOUT" in EL section.

MAT566A

Diagnostic Procedure

NAAT0064

GI
MA
EM
LC
EC
FE
CL
MT
AT
TF
PD
AX
SU
BR
ST
RS
BT
HA
SC
EL
IDX

1	CHECK GROUND CIRCUIT
<ol style="list-style-type: none"> Turn ignition switch to "OFF" position. Disconnect terminal cord assembly connector in engine compartment. Check resistance between terminal 7 and ground. 	
<p>Sub-harness connector (B64)</p> <p style="text-align: right;">SAT332I</p>	
<p>Is resistance approx. 20 - 40Ω?</p>	
Yes	▶ GO TO 2.
No	<ol style="list-style-type: none"> Remove control valve assembly. Refer to AT-225. Check the following items: <ul style="list-style-type: none"> Shift solenoid valve B Refer to "Component Inspection", AT-160. Harness of terminal cord assembly for short or open

2	CHECK POWER SOURCE CIRCUIT
<ol style="list-style-type: none"> Turn ignition switch to "OFF" position. Disconnect TCM harness connector. Check resistance between terminal 7 and TCM harness connector terminal 7. 	
<p>Sub-harness connector (B64)</p> <p style="text-align: right;">SAT077J</p>	
<p>Is resistance approx. 0Ω?</p>	
<p>If OK, check harness for short to ground and short to power.</p>	
Yes	▶ GO TO 3.
No	▶ Repair open circuit or short to ground or short to power in harness or connectors.

3	CHECK DTC
<p>Perform Diagnostic Trouble Code (DTC) confirmation procedure, AT-157.</p> <p style="text-align: center;">OK or NG</p>	
OK	▶ INSPECTION END
NG	<ol style="list-style-type: none"> Perform TCM input/output signal inspection. If NG, recheck TCM pin terminals for damage or loose connection with harness connector.

DTC P0755 SHIFT SOLENOID VALVE B

Component Inspection

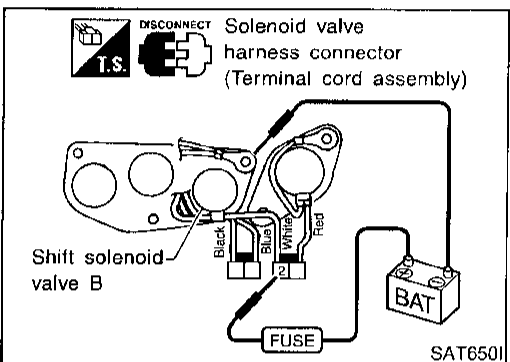
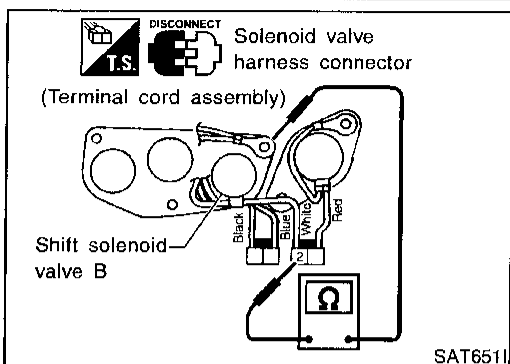

Component Inspection SHIFT SOLENOID VALVE B

NAAT0065

NAAT0065S01

- For removal, refer to AT-225.

Resistance Check

NAAT0065S0101

- Check resistance between terminal 2 and ground.

Solenoid valve	Terminal No.		Resistance (Approx.)
Shift solenoid valve B	2	Ground	20 - 40Ω

Operation Check

NAAT0065S0102

- Check solenoid valve by listening for its operating sound while applying battery voltage to the terminal 2 and ground.

DTC P1705 THROTTLE POSITION SENSOR

Description

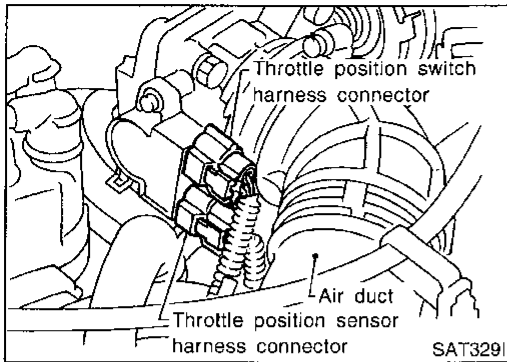

Description

- Throttle position sensor
The throttle position sensor detects the throttle valve position and sends a signal to the TCM.
- Throttle position switch
Consists of a wide open throttle position switch and a closed throttle position switch. The wide open position switch sends a signal to the TCM when the throttle valve is open at least 1/2 of the full throttle position. The closed throttle position switch sends a signal to the TCM when the throttle valve is fully closed.

CONSULT REFERENCE VALUE IN DATA MONITOR MODE

Remarks: Specification data are reference values.

Monitor item	Condition	Specification
Throttle position sensor	Fully-closed throttle	Approximately 0.5V
	Fully-open throttle	Approximately 4V

TCM TERMINALS AND REFERENCE VALUE

Remarks: Specification data are reference values.

Terminal No.	Wire color	Item	Condition	Judgement standard
14	OR/W	Closed throttle position switch (in throttle position switch)	When releasing accelerator pedal after warming up engine.	Battery voltage
			When depressing accelerator pedal after warming up engine.	1V or less
21	OR/B	Wide open throttle position switch (in throttle position switch)	When depressing accelerator pedal more than half-way after warming up engine.	Battery voltage
			When releasing accelerator pedal after warming up engine.	1V or less
31	P/B	Throttle position sensor (Power source)	—	4.5 - 5.5V
34	P	Throttle position sensor	When depressing accelerator pedal slowly after warming up engine. (Voltage rises gradually in response to throttle position.)	Fully-closed throttle: Approximately 0.5V Fully-open throttle: Approximately 4V
35	B	Throttle position sensor (Ground)	—	—

ON BOARD DIAGNOSIS LOGIC

Diagnostic trouble code	Malfunction is detected when ...	Check item (Possible cause)
P1705 : TP SEN/CIRC A/T P1705 : P1705 MIL Code No. 1206	TCM receives an excessively low or high voltage from the sensor.	<ul style="list-style-type: none"> ● Harness or connectors (The solenoid circuit is open or shorted.) ● Throttle position sensor ● Throttle position switch

DTC P1705 THROTTLE POSITION SENSOR

Description (Cont'd)

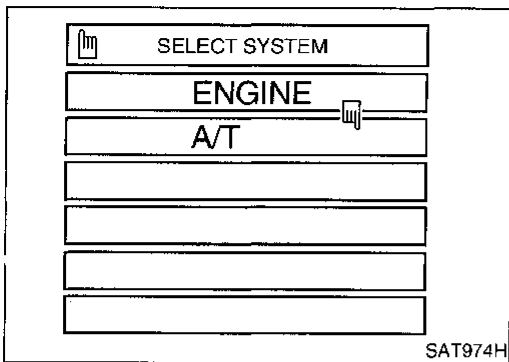

SAT974H

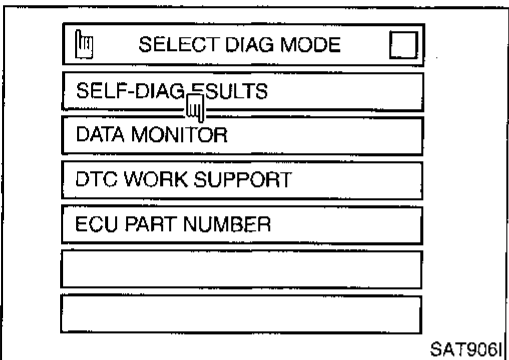

SAT906I

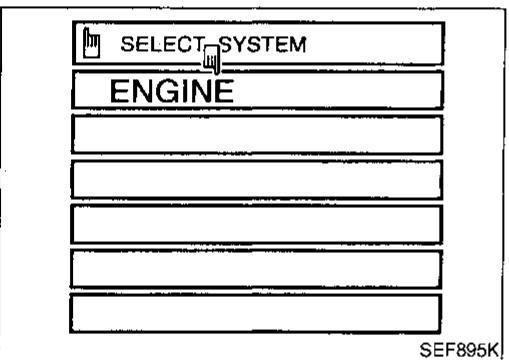

SEF895K

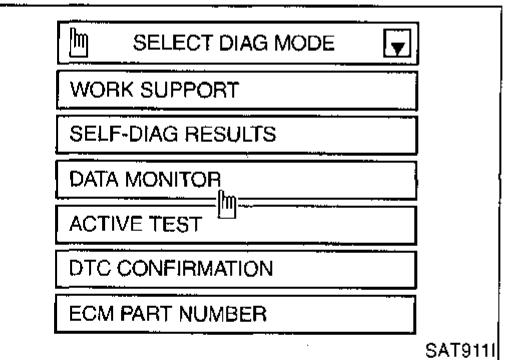

SAT911I

DIAGNOSTIC TROUBLE CODE (DTC) CONFIRMATION PROCEDURE

NAAT0066301

CAUTION:

Always drive vehicle at a safe speed.

NOTE:

If "DIAGNOSTIC TROUBLE CODE CONFIRMATION PROCEDURE" has been previously conducted, always turn ignition switch "OFF" and wait at least 5 seconds before conducting the next test.

After the repair, perform the following procedure to confirm the malfunction is eliminated.

④ With CONSULT

- 1) Turn ignition switch "ON" and select "DATA MONITOR" mode for "A/T" with CONSULT.
- 2) Check the following.

Accelerator pedal condition	THRTL POS SEN	CLOSED THL/SW	W/O THRL/P-SW
Fully released	Less than 4.7V	ON	OFF
Partially depressed	0.1 - 4.6V	OFF	OFF
Fully depressed	More than 1.9 - 4.6V	OFF	ON

If the check result is NG, go to "DIAGNOSTIC PROCEDURE", AT-165.

If the check result is OK, go to following step.

- 3) Turn ignition switch "ON" and select "DATA MONITOR" mode for "ENGINE" with CONSULT.
- 4) Start engine and maintain the following conditions for at least 3 consecutive seconds. Then release accelerator pedal completely.

VHCL SPEED SE: 10 km/h (6 MPH) or more

THRTL POS SEN: Approximately 3V or less

Selector lever: D position (OD "ON")

If the check result is NG, go to "DIAGNOSTIC PROCEDURE", AT-165.

If the check result is OK, go to following step.

- 5) Maintain the following conditions for at least 3 consecutive seconds. Then release accelerator pedal completely.

VHCL SPEED SE: 10 km/h (6 MPH) or more

Accelerator pedal: Wide open throttle

Selector lever: D position (OD "ON")

④ With GST

- 1) Start engine.
- 2) Drive vehicle under the following conditions:
Selector lever in "D" (OD "ON") position, vehicle speed higher than 10 km/h (6 MPH), throttle opening greater than 1/2 of the full throttle position and driving for more than 3 seconds.
- 3) Select "MODE 7" with GST.

④ No Tools

- 1) Start engine.
- 2) Drive vehicle under the following conditions:
Selector lever in "D" (OD "ON") position, vehicle speed higher than 10 km/h (6 MPH), throttle opening greater than 1/2 of the full throttle position and driving for more than 3 seconds.

DTC P1705 THROTTLE POSITION SENSOR

Description (Cont'd)

- 3) Perform self-diagnosis for ECM.
Refer to EC section ["Malfunction Indicator Lamp (MIL)", "ON BOARD DIAGNOSTIC SYSTEM DESCRIPTION"].

GI

MA

EM

LC

EC

FE

CL

MT

AT

TF

PD

AX

SU

BR

ST

RS

BT

HA

SC

EL

IDX

DTC P1705 THROTTLE POSITION SENSOR

Wiring Diagram — AT — TPS

Wiring Diagram — AT — TPS

NAAT0199

AT-TPS-01

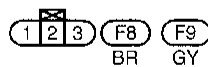
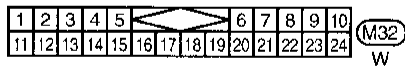
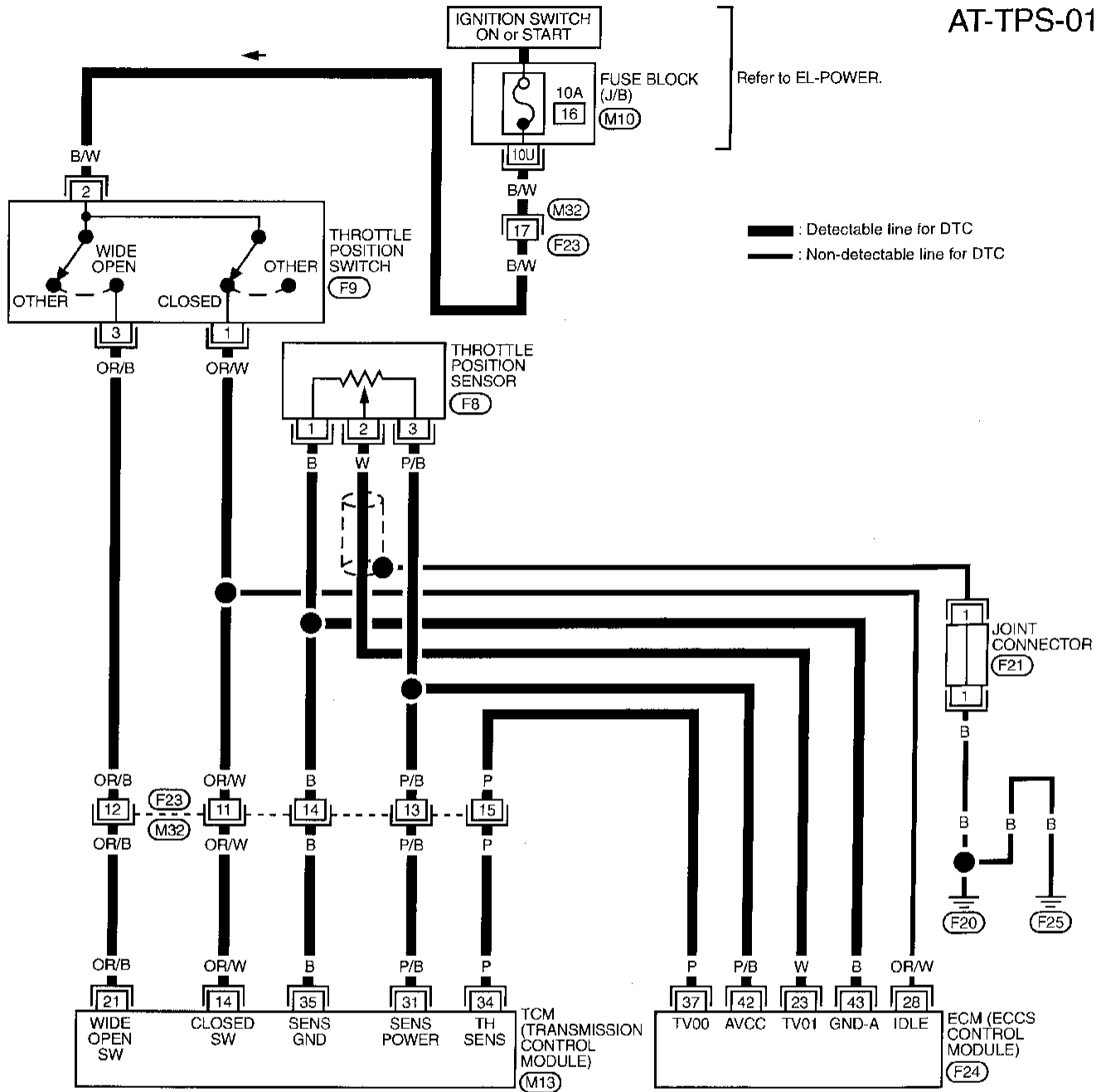

Refer to last page (Foldout page).

M10

F24

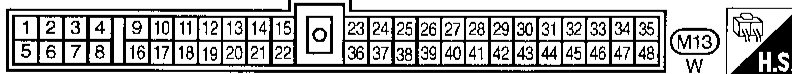
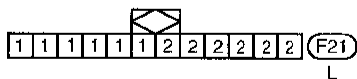

Diagnostic Procedure

NAAT0067

GI
MA
EM
LC
EC
FE
CL
MT
AT
TF
PD
AX
SU
BR
ST
RS
BT
HA
SC
EL
DX

1	CHECK DTC WITH ECM	
Perform diagnostic test mode II (self-diagnostic results) for engine control. Refer to EC section ["Malfunction Indicator Lamp (MIL)", "ON BOARD DIAGNOSTIC SYSTEM DESCRIPTION"].		
OK or NG		
OK	▶	GO TO 2.
NG	▶	Check throttle position sensor circuit for engine control. Refer to EC section ("DTC P0120 THROTTLE POSITION SENSOR").

2	CHECK INPUT SIGNAL																															
<p>Ⓟ With CONSULT</p> <ol style="list-style-type: none"> 1. Turn ignition switch to "ON" position. (Do not start engine.) 2. Select "ECU INPUT SIGNALS" in "DATA MONITOR" mode for "A/T" with CONSULT. 3. Read out the value of "THRTL POS SEN". <p>Voltage: Fully-closed throttle: Approximately 0.5V Fully-open throttle: Approximately 4V</p> <div style="border: 1px solid black; padding: 5px; margin: 10px 0;"> <table style="width: 100%; border-collapse: collapse;"> <tr> <td>☆ MONITOR</td> <td>☆ NO FAIL</td> <td style="text-align: right;">▼</td> </tr> <tr> <td>VHCL/S SE•A/T</td> <td>0km/h</td> <td></td> </tr> <tr> <td>VHCL/S SE•MTR</td> <td>5km/h</td> <td></td> </tr> <tr> <td>THRTL POS SEN</td> <td>0.4V</td> <td></td> </tr> <tr> <td>FLUID TEMP SE</td> <td>1.2V</td> <td></td> </tr> <tr> <td>BATTERY VOLT</td> <td>13.4V</td> <td></td> </tr> <tr> <td>ENGINE SPEED</td> <td>1024rpm</td> <td></td> </tr> <tr> <td>OVERDRIVE SW</td> <td>O N</td> <td></td> </tr> <tr> <td>P/N POSI SW</td> <td>O N</td> <td></td> </tr> <tr> <td>R POSITION SW</td> <td>OFF</td> <td></td> </tr> </table> </div> <div style="border: 1px solid black; text-align: center; margin: 5px 0; padding: 2px;">RECORD</div> <p style="text-align: right; margin-right: 20px;">SAT076H</p> <p>ⓧ Without CONSULT</p> <ol style="list-style-type: none"> 1. Turn ignition switch to "ON" position. (Do not start engine.) 2. Check voltage between TCM terminals 34 and 35 while accelerator pedal is depressed slowly. <p>Voltage: Fully-closed throttle valve: Approximately 0.5V Fully-open throttle valve: Approximately 4V (Voltage rises gradually in response to throttle position.)</p> <div style="text-align: center; margin: 10px 0;"> <p>The diagram shows a voltmeter (V) with its positive terminal connected to terminal 34 (labeled 'P') and its negative terminal connected to terminal 35 (labeled 'B'). Above the TCM connector, there are icons for 'H.S.' (Honda Service) and 'CONNECT' (CONSULT) connectors.</p> </div> <p style="text-align: right; margin-right: 20px;">SAT940IB</p> <p style="text-align: center;">OK or NG</p>			☆ MONITOR	☆ NO FAIL	▼	VHCL/S SE•A/T	0km/h		VHCL/S SE•MTR	5km/h		THRTL POS SEN	0.4V		FLUID TEMP SE	1.2V		BATTERY VOLT	13.4V		ENGINE SPEED	1024rpm		OVERDRIVE SW	O N		P/N POSI SW	O N		R POSITION SW	OFF	
☆ MONITOR	☆ NO FAIL	▼																														
VHCL/S SE•A/T	0km/h																															
VHCL/S SE•MTR	5km/h																															
THRTL POS SEN	0.4V																															
FLUID TEMP SE	1.2V																															
BATTERY VOLT	13.4V																															
ENGINE SPEED	1024rpm																															
OVERDRIVE SW	O N																															
P/N POSI SW	O N																															
R POSITION SW	OFF																															
OK	▶	GO TO 3.																														
NG	▶	Check harness for short or open between ECM and TCM regarding throttle position sensor circuit. (Main harness)																														

DTC P1705 THROTTLE POSITION SENSOR

Diagnostic Procedure (Cont'd)

3 CHECK THROTTLE POSITION SWITCH CIRCUIT (With CONSULT)

With CONSULT

1. Turn ignition switch to "ON" position. (Do not start engine.)
2. Select "ECU INPUT SIGNALS" in "DATA MONITOR" mode for "A/T" with CONSULT.
3. Read out "CLOSED THL/SW" and "W/O THRL/P-SW" depressing and releasing accelerator pedal. Check the signal of throttle position switch is indicated properly.

Accelerator pedal condition	Data monitor	
	CLOSED THL/SW	W/O THRL/P-SW
Released	ON	OFF
Fully depressed	OFF	ON

MTBL0011

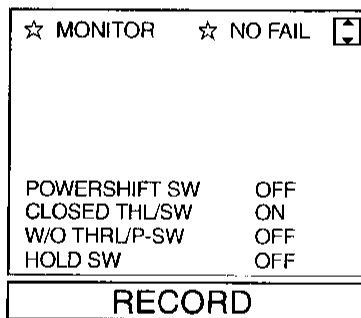
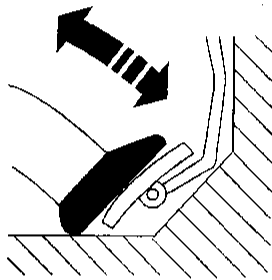

SAT0521

OK or NG

OK ► GO TO 5.

NG ► **Check the following items:**

- Throttle position switch
Refer to "Component Inspection", AT-167.
- Harness for short or open between ignition switch and throttle position switch (Main harness)
- Harness for short or open between throttle position switch and TCM (Main harness)

4 CHECK THROTTLE POSITION SWITCH CIRCUIT (Without CONSULT)

Without CONSULT

1. Turn ignition switch to "ON" position. (Do not start engine.)
2. Check voltage between TCM terminals 14, 21 and ground while depressing, and releasing accelerator pedal slowly. (after warming up engine)

Accelerator pedal condition	Voltage	
	Terminal No. 14	Terminal No. 21
Released	Battery voltage	1V or less
Fully depressed	1V or less	Battery voltage

MTBL0073

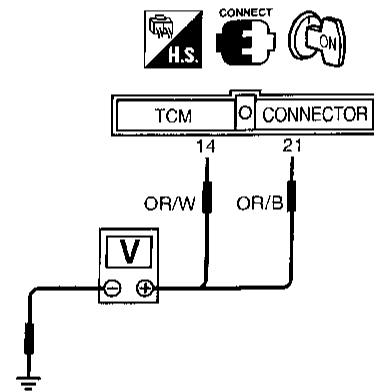
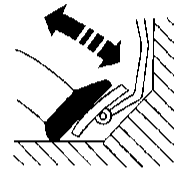

SAT078J

OK or NG

OK ► GO TO 5.

NG ► **Check the following items:**

- Throttle position switch
Refer to "Component Inspection", AT-167.
- Harness for short or open between ignition switch and throttle position switch (Main harness)
- Harness for short or open between throttle position switch and TCM (Main harness)

DTC P1705 THROTTLE POSITION SENSOR

Diagnostic Procedure (Cont'd)

5	CHECK DTC
Perform Diagnostic Trouble Code (DTC) confirmation procedure, AT-162.	
OK or NG	
OK	▶ INSPECTION END
NG	1. Perform TCM input/output signal inspection. 2. If NG, recheck TCM pin terminals for damage or loose connection with harness connector.

GI
MA
EM
LC
EC
FE
CL
MT
AT

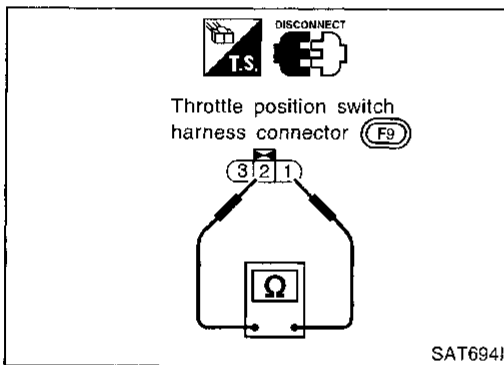

Component Inspection THROTTLE POSITION SWITCH Closed Throttle Position Switch (Idle Position)

NAAT0205
NAAT0205S01
NAAT0205S0101

- Check continuity between terminals 1 and 2.

Accelerator pedal condition	Continuity
Released	Yes
Depressed	No

- To adjust closed throttle position switch, refer to EC section ("Basic Inspection", "TROUBLE DIAGNOSIS — Basic Inspection").

PD
AX
SU
BR
ST
RS
BT

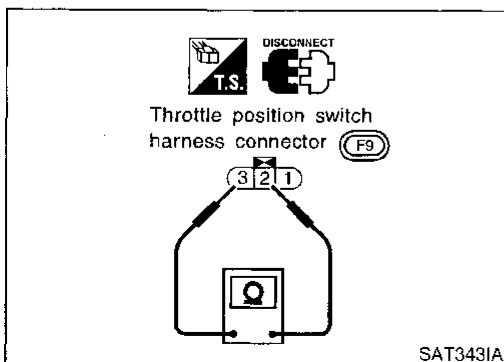

Wide Open Throttle Position Switch

NAAT0205S0102

- Check continuity between terminals 2 and 3.

Accelerator pedal condition	Continuity
Released	No
Depressed	Yes

HA
SC
EL
IDX

DTC P1760 OVERRUN CLUTCH SOLENOID VALVE

Description

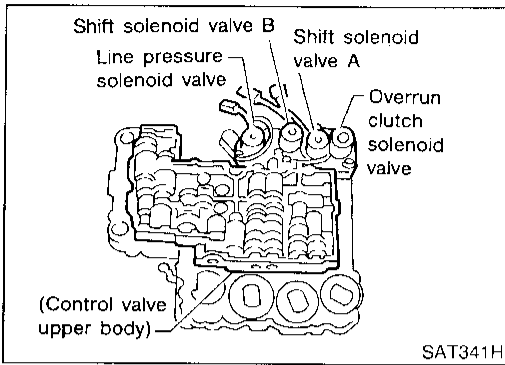

Description

The overrun clutch solenoid valve is activated by the TCM in response to signals sent from the inhibitor switch, overdrive control switch, vehicle speed and throttle position sensors. The overrun clutch operation will then be controlled.

NAAAT0068

TCM TERMINALS AND REFERENCE VALUE

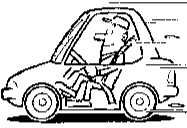

NAAAT0068S02

Remarks: Specification data are reference values.

Terminal No.	Wire color	Item	Condition	Judgement standard
8	L/B	Overrun clutch solenoid valve	 When overrun clutch solenoid valve operates.	Battery voltage
			When overrun clutch solenoid valve does not operate.	1V or less

ON BOARD DIAGNOSIS LOGIC

NAAAT0068S03

Diagnostic trouble code	Malfunction is detected when ...	Check item (Possible cause)
<ul style="list-style-type: none">  : O/R CLTCH SOL/CIRC  : P1760  : MIL Code No. 1203 	TCM detects an improper voltage drop when it tries to operate the solenoid valve.	<ul style="list-style-type: none"> • Harness or connectors (The solenoid circuit is open or shorted.) • Overrun clutch solenoid valve

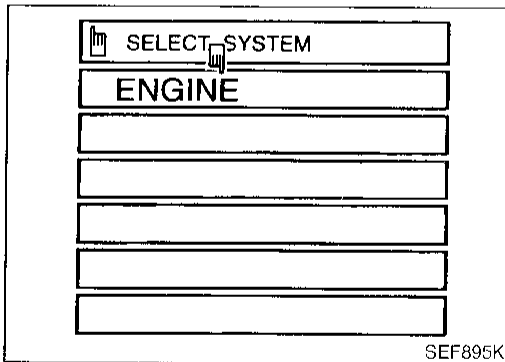

SEF895K

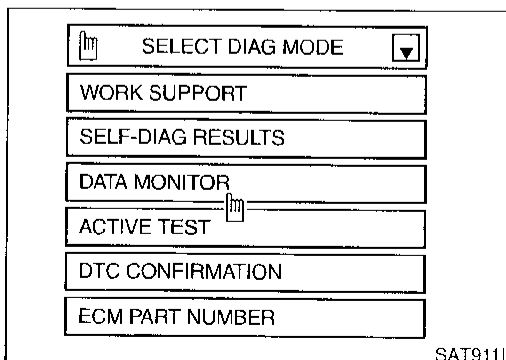

SAT911J

DIAGNOSTIC TROUBLE CODE (DTC) CONFIRMATION PROCEDURE

NAAAT0068S01

CAUTION:

Always drive vehicle at a safe speed.

NOTE:

If "DIAGNOSTIC TROUBLE CODE CONFIRMATION PROCEDURE" has been previously conducted, always turn ignition switch "OFF" and wait at least 5 seconds before conducting the next test.

TESTING CONDITION:

Always drive vehicle on a level road to improve accuracy of test.

After the repair, perform the following procedure to confirm the malfunction is eliminated.

With CONSULT

- 1) Turn ignition switch "ON" and select "DATA MONITOR" mode for "ENGINE" with CONSULT.
- 2) Start engine.
- 3) Accelerate vehicle to a speed of more than 10 km/h (6MPH) in "D" position (OD "ON").
- 4) Release accelerator pedal completely in "D" position (OD "OFF").

DTC P1760 OVERRUN CLUTCH SOLENOID VALVE

Description (Cont'd)

 **With GST**

- 1) Start engine.
- 2) Drive vehicle under the following conditions:
Selector lever in "D" position, overdrive control switch in "OFF" position and vehicle speed higher than 10 km/h (6 MPH).
- 3) Select "MODE 7" with GST.

 **No Tools**

- 1) Start engine.
- 2) Drive vehicle under the following conditions:
Selector lever in "D" position, overdrive control switch in "OFF" position and vehicle speed higher than 10 km/h (6 MPH).
- 3) Perform self-diagnosis for ECM.
Refer to EC section ["Malfunction Indicator Lamp (MIL)", "ON BOARD DIAGNOSTIC SYSTEM DESCRIPTION"].

GI

MA

EM

LC

EC

FE

CL

MT

AT

TF

PD

AX

SU

BR

ST

RS

BT

HA

SC

EL

IDX

DTC P1760 OVERRUN CLUTCH SOLENOID VALVE

Wiring Diagram — AT — OVRCSV

Wiring Diagram — AT — OVRCSV

NAAT0200

AT-OVRCSV-01

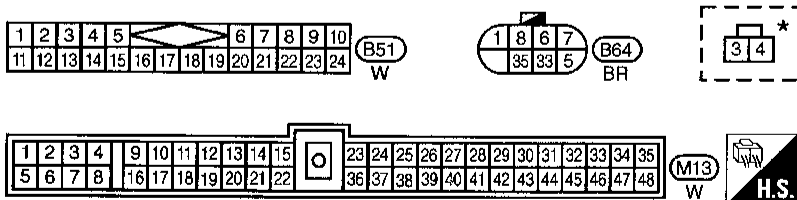
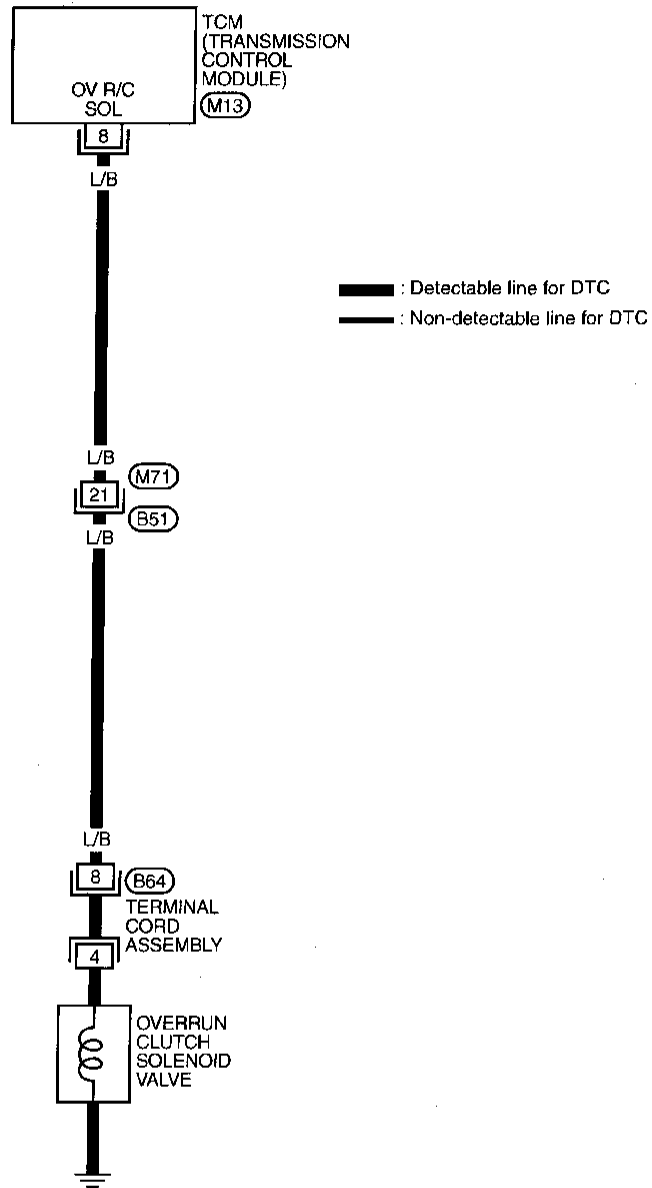

Diagnostic Procedure

NAAT0069

GI
MA
EM
LC
EC
FE
CL
MT
AT
TF
PD
AX
SU
BR
ST
RS
BT
HA
SC
EL
IDX

1	CHECK GROUND CIRCUIT
<ol style="list-style-type: none"> Turn ignition switch to "OFF" position. Disconnect terminal cord assembly connector in engine compartment. Check resistance between terminal 8 and ground. 	
<p>Sub-harness connector (B64)</p> <p style="text-align: right;">SAT334I</p>	
<p>Is resistance approx. 20 - 40Ω?</p>	
Yes	▶ GO TO 2.
No	<ol style="list-style-type: none"> Remove control valve assembly. Refer to AT-225. Check the following items: <ul style="list-style-type: none"> Overrun clutch solenoid valve Refer to "Component Inspection", AT-172. Harness of terminal cord assembly for short or open

2	CHECK POWER SOURCE CIRCUIT
<ol style="list-style-type: none"> Turn ignition switch to "OFF" position. Disconnect TCM harness connector. Check resistance between terminal 8 and TCM harness connector terminal 8. 	
<p>Sub-harness connector (B64)</p> <p style="text-align: right;">SAT079J</p>	
<p>Is resistance approx 0Ω?</p>	
<p>If OK, check harness for short to ground and short to power.</p>	
Yes	▶ GO TO 3.
No	▶ Repair open circuit or short to ground or short to power in harness or connectors.

3	CHECK DTC
<p>Perform Diagnostic Trouble Code (DTC) confirmation procedure, AT-168.</p>	
<p>OK or NG</p>	
OK	▶ INSPECTION END
NG	<ol style="list-style-type: none"> Perform TCM input/output signal inspection. If NG, recheck TCM pin terminals for damage or loose connection with harness connector.

DTC P1760 OVERRUN CLUTCH SOLENOID VALVE

Component Inspection

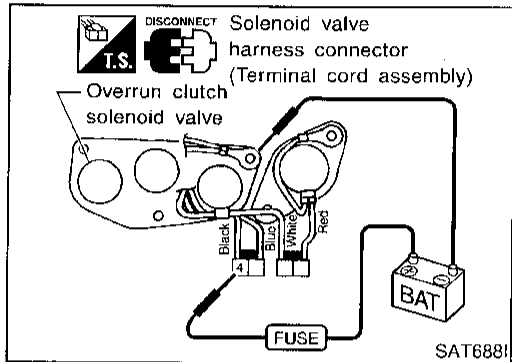
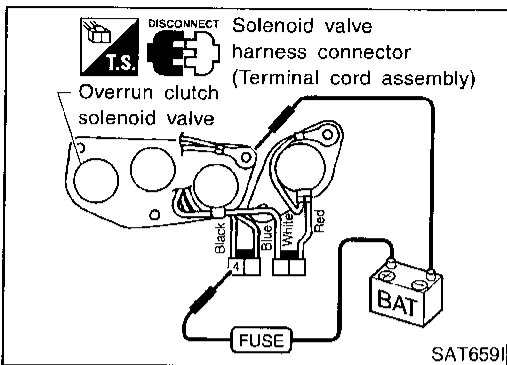

Component Inspection OVERRUN CLUTCH SOLENOID VALVE

NAAT0070

NAAT0070S01

- For removal, refer to AT-225.

Resistance Check

NAAT0070S0101

- Check resistance between terminal 4 and ground.

Solenoid valve	Terminal No.		Resistance (Approx.)
Overrun clutch solenoid valve	4	Ground	20 - 40Ω

Operation Check

NAAT0070S0102

- Check solenoid valve by listening for its operating sound while applying battery voltage to the terminal 4 and ground.

DTC BATT/FLUID TEMP SEN A/T FLUID TEMPERATURE SENSOR CIRCUIT AND TCM POWER SOURCE

Description

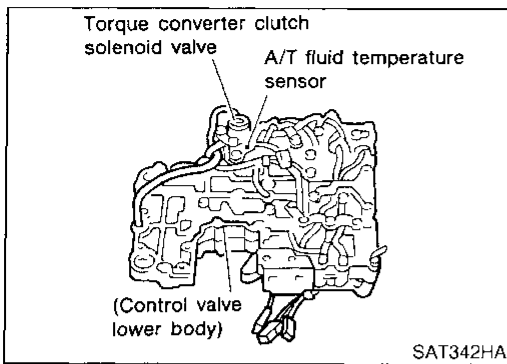

Description

The A/T fluid temperature sensor detects the A/T fluid temperature and sends a signal to the TCM.

NAAT0172

GI
MA
EM
LC
EC
FE
CL
MT
AT

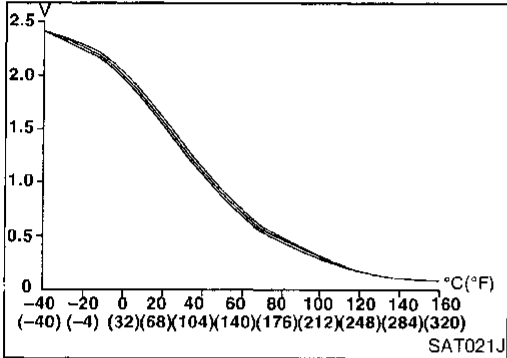

CONSULT REFERENCE VALUE IN DATA MONITOR MODE

Remarks: Specification data are reference values.

NAAT0172S02

Monitor item	Condition	Specification
A/T fluid temperature sensor	Cold [20°C (68°F)]	Approximately 1.5V
	Hot [80°C (176°F)]	Approximately 0.5V

TF
PD
AX

TCM TERMINALS AND REFERENCE VALUE

Remarks: Specification data are reference values.

NAAT0172S03

Terminal No.	Wire color	Item	Condition	Judgement standard
4	W/R	Power source	When turning ignition switch to "ON".	Battery voltage
			When turning ignition switch to "OFF".	1V or less
9	W/R	Power source	Same as No. 4	
23	R/Y	Power source (Memory back-up)	When turning ignition switch to "OFF".	Battery voltage
			When turning ignition switch to "ON".	Battery voltage
33	BR	A/T fluid temperature sensor	When ATF temperature is 20°C (68°F).	Approximately 1.5V
			When ATF temperature is 80°C (176°F).	Approximately 0.5V
35	B	Throttle position sensor (Ground)	—	—

SU
BR
ST
RS
BT
HA
SC
EL
DX

DTC BATT/FLUID TEMP SEN A/T FLUID TEMPERATURE SENSOR CIRCUIT AND TCM POWER SOURCE

Description (Cont'd)

ON BOARD DIAGNOSIS LOGIC

NAATD172S04

Diagnostic trouble code	Malfunction is detected when ...	Check item (Possible cause)
P : BATT/FLUID TEMP SEN NO TOOLS : 8th judgement flicker	TCM receives an excessively low or high voltage from the sensor.	<ul style="list-style-type: none"> • Harness or connectors (The sensor circuit is open or shorted.) • A/T fluid temperature sensor

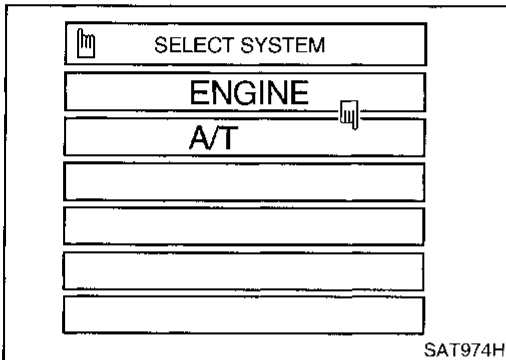

DIAGNOSTIC TROUBLE CODE (DTC) CONFIRMATION PROCEDURE

NAATD172S01

After the repair, perform the following procedure to confirm the malfunction is eliminated.

With CONSULT

- 1) Start engine.
- 2) Select "DATA MONITOR" mode for "A/T" with CONSULT.
- 3) Drive vehicle under the following conditions:
Selector lever in "D" position, vehicle speed higher than 20 km/h (12 MPH).

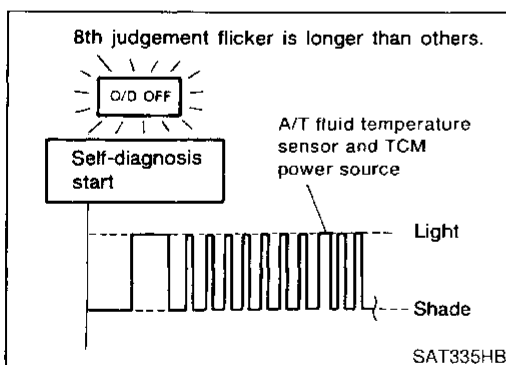
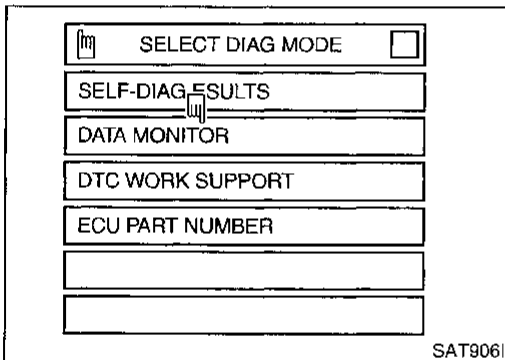

No Tools

- 1) Start engine.
- 2) Drive vehicle under the following conditions:
Selector lever in "D" position, vehicle speed higher than 20 km/h (12 MPH).
- 3) Perform self-diagnosis.
Refer to TCM SELF-DIAGNOSTIC PROCEDURE (No Tools), AT-44.

DTC BATT/FLUID TEMP SEN A/T FLUID TEMPERATURE SENSOR CIRCUIT AND TCM POWER SOURCE

Wiring Diagram — AT — BA/FTS

Wiring Diagram — AT — BA/FTS

NAATO201

AT-BA/FTS-01

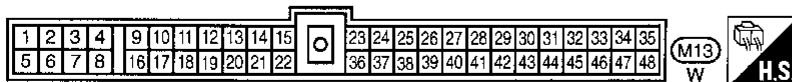
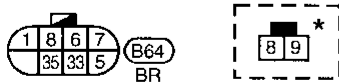
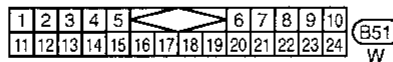
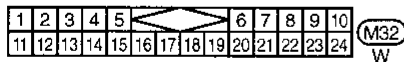
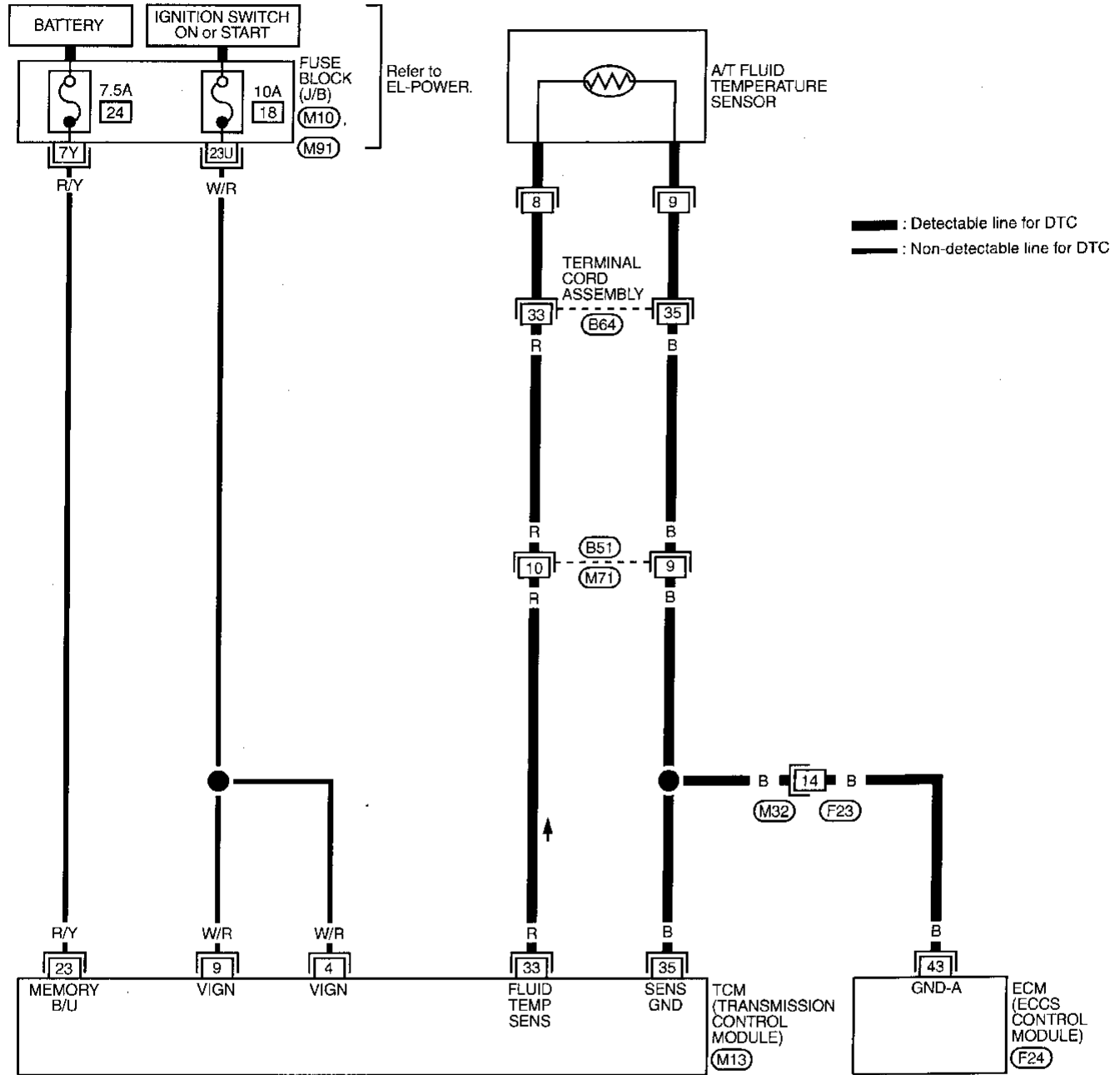

Refer to last page (Foldout page).

(M10)

(M91)

(F24)

* : This connector is not shown in "HARNESS LAYOUT" in EL section.

MAT569A

DTC BATT/FLUID TEMP SEN A/T FLUID TEMPERATURE SENSOR CIRCUIT AND TCM POWER SOURCE

Diagnostic Procedure

Diagnostic Procedure

NAAT0173

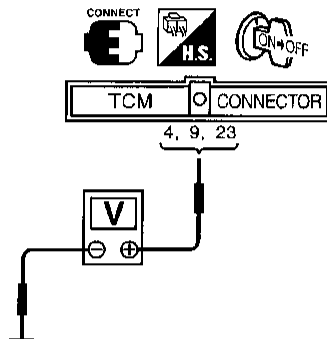
1	CHECK TCM POWER SOURCE
<p>1. Turn ignition switch to "ON" position. (Do not start engine.)</p> <p>2. Check voltage between TCM terminals 4, 9, 23 and ground. Voltage: Battery voltage</p>  <p style="text-align: right;">SAT909I</p> <p>3. Turn ignition switch to "OFF" position.</p> <p>4. Check voltage between TCM terminal 23 and ground. Voltage: Battery voltage</p> <p style="text-align: center;">OK or NG</p>	
OK	▶ GO TO 2.
NG	▶ Check the following items: <ul style="list-style-type: none"> ● Harness for short or open between ignition switch and TCM (Main harness) ● Ignition switch and fuse Refer to EL section ("POWER SUPPLY ROUTING").

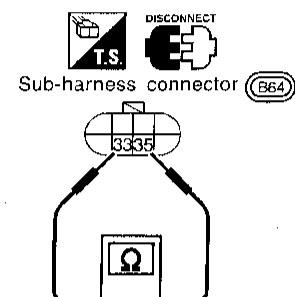
2	CHECK A/T FLUID TEMPERATURE SENSOR WITH TERMINAL CORD ASSEMBLY
<p>1. Turn ignition switch to "OFF" position.</p> <p>2. Disconnect terminal cord assembly connector in engine compartment.</p> <p>3. Check resistance between terminals 33 and 35 when A/T is cold [20°C (68°F)].</p>  <p style="text-align: right;">SAT191IA</p> <p style="text-align: center;">Is resistance approx. 2.5kΩ?</p>	
Yes	▶ GO TO 3.
No	▶ <ul style="list-style-type: none"> 1. Remove oil pan. 2. Check the following items: <ul style="list-style-type: none"> ● A/T fluid temperature sensor Refer to "Component Inspection", AT-177. ● Harness of terminal cord assembly for short or open

DTC BATT/FLUID TEMP SEN A/T FLUID TEMPERATURE SENSOR CIRCUIT AND TCM POWER SOURCE

Diagnostic Procedure (Cont'd)

3	CHECK INPUT SIGNAL OF A/T FLUID TEMPERATURE SENSOR																				
<p>Ⓜ With CONSULT</p> <ol style="list-style-type: none"> Start engine. Select "ECU INPUT SIGNALS" in "DATA MONITOR" mode for "A/T" with CONSULT. Read out the value of "FLUID TEMP SE". <p>Voltage: Cold [20°C (68°F)] → Hot [80°C (176°F)]: Approximately 1.5V → 0.5V</p> <div style="border: 1px solid black; padding: 5px; margin: 10px 0;"> <table style="width: 100%; border-collapse: collapse;"> <tr> <td style="text-align: center;">☆ MONITOR ☆ NO FAIL</td> <td style="text-align: right;">▼</td> </tr> <tr> <td>VHCL/S SE-A/T</td> <td style="text-align: right;">0km/h</td> </tr> <tr> <td>VHCL/S SE-MTR</td> <td style="text-align: right;">5km/h</td> </tr> <tr> <td>THRTL POS SEN</td> <td style="text-align: right;">0.4V</td> </tr> <tr> <td>FLUID TEMP SE</td> <td style="text-align: right;">1.2V</td> </tr> <tr> <td>BATTERY VOLT</td> <td style="text-align: right;">13.4V</td> </tr> <tr> <td>ENGINE SPEED</td> <td style="text-align: right;">1024rpm</td> </tr> <tr> <td>OVERDRIVE SW</td> <td style="text-align: right;">O N</td> </tr> <tr> <td>P/N POSI SW</td> <td style="text-align: right;">O N</td> </tr> <tr> <td>R POSITION SW</td> <td style="text-align: right;">OFF</td> </tr> </table> </div> <div style="border: 1px solid black; padding: 5px; text-align: center; margin: 5px 0;">RECORD</div> <p style="text-align: right; font-size: small;">SAT076H</p>		☆ MONITOR ☆ NO FAIL	▼	VHCL/S SE-A/T	0km/h	VHCL/S SE-MTR	5km/h	THRTL POS SEN	0.4V	FLUID TEMP SE	1.2V	BATTERY VOLT	13.4V	ENGINE SPEED	1024rpm	OVERDRIVE SW	O N	P/N POSI SW	O N	R POSITION SW	OFF
☆ MONITOR ☆ NO FAIL	▼																				
VHCL/S SE-A/T	0km/h																				
VHCL/S SE-MTR	5km/h																				
THRTL POS SEN	0.4V																				
FLUID TEMP SE	1.2V																				
BATTERY VOLT	13.4V																				
ENGINE SPEED	1024rpm																				
OVERDRIVE SW	O N																				
P/N POSI SW	O N																				
R POSITION SW	OFF																				
<p>ⓧ Without CONSULT</p> <ol style="list-style-type: none"> Start engine. Check voltage between TCM terminal 33 and ground while warming up A/T. <p>Voltage: Cold [20°C (68°F)] → Hot [80°C (176°F)]: Approximately 1.5V → 0.5V</p> <div style="text-align: center; margin: 10px 0;"> </div> <p style="text-align: center;">OK or NG</p> <p style="text-align: right; font-size: small;">SAT913IC</p>																					
OK	▶ GO TO 4.																				
NG	▶ Check the following item: <ul style="list-style-type: none"> Harness for short or open between TCM and terminal cord assembly (Main harness) 																				

4	CHECK DTC
<p>Perform Diagnostic Trouble Code (DTC) confirmation Procedure, AT-174.</p> <p style="text-align: center;">OK or NG</p>	
OK	▶ INSPECTION END
NG	▶ <ul style="list-style-type: none"> Perform TCM input/output signal inspection. If NG, recheck TCM pin terminals for damage or loose connection with harness connector.

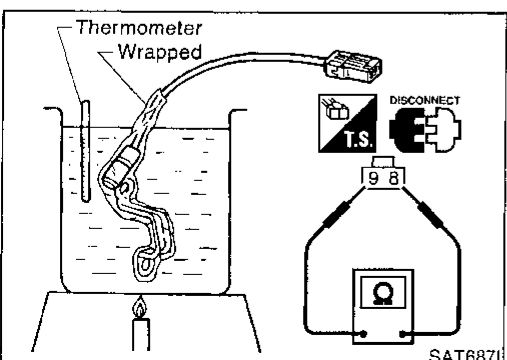

Component Inspection A/T FLUID TEMPERATURE SENSOR

NAAT0174
NAAT0174S01

- For removal, refer to AT-225.
- Check resistance between terminals 8 and 9 while changing temperature as shown at left.

Temperature °C (°F)	Resistance
20 (68)	Approximately 2.5 kΩ
80 (176)	Approximately 0.3 kΩ

GI
MA
EM
LC
EC
FE
CL
MT
AT
TF
PD
AX
SU
BR
ST
RS
BT
HA
SC
EL
IDX

VEHICLE SPEED SENSOR-MTR

Description

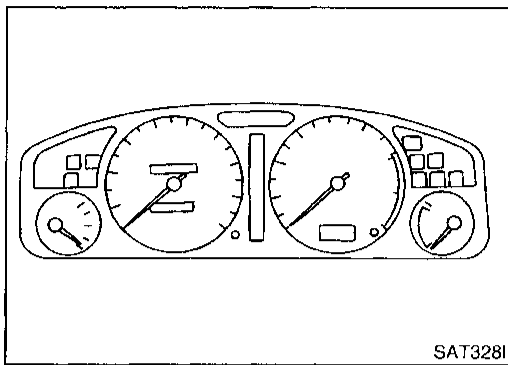

Description

The vehicle speed sensor-MTR is built into the speedometer assembly. The sensor functions as an auxiliary device to the revolution sensor when it is malfunctioning. The TCM will then use a signal sent from the vehicle speed sensor-MTR.

NAAT0071

TCM TERMINALS AND REFERENCE VALUE

NAAT0071S02

Remarks: Specification data are reference values.

Terminal No.	Wire color	Item	Condition	Judgement standard
27	W/L	Vehicle speed sensor	When moving vehicle at 2 to 3 km/h (1 to 2 MPH) for 1 m (3 ft) or more.	Voltage varies between less than 1V and more than 4.5V

ON BOARD DIAGNOSIS LOGIC

NAAT0071S03

Diagnostic trouble code	Malfunction is detected when ...	Check item (Possible cause)
Ⓜ : VHCL SPEED SEN-MTR	TCM does not receive the proper voltage signal from the sensor.	<ul style="list-style-type: none"> • Harness or connectors (The sensor circuit is open or shorted.) • Vehicle speed sensor
Ⓧ : 2nd judgement flicker		

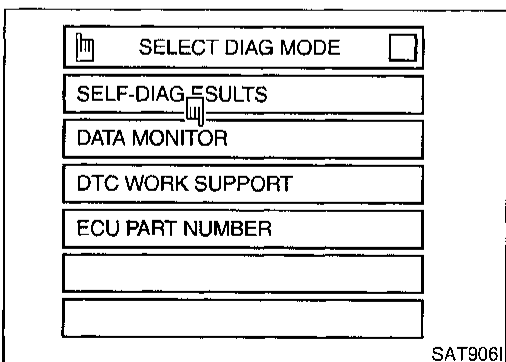
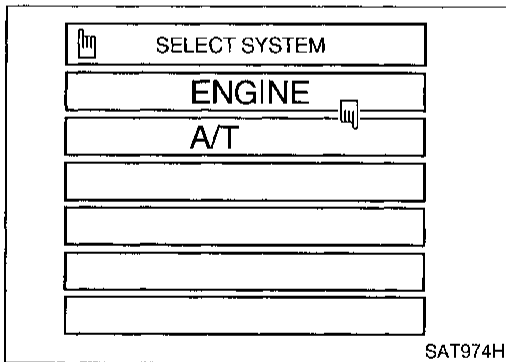

DIAGNOSTIC TROUBLE CODE (DTC) CONFIRMATION PROCEDURE

NAAT0071S01

CAUTION:

- Always drive vehicle at a safe speed.
- If conducting this "DTC CONFIRMATION PROCEDURE" again, always turn ignition switch "OFF" and wait at least 5 seconds before continuing.

After the repair, perform the following procedure to confirm the malfunction is eliminated.

Ⓜ With CONSULT

- 1) Turn ignition switch "ON" and select "DATA MONITOR" mode for "A/T" with CONSULT.
- 2) Start engine and accelerate vehicle from 0 to 25 km/h (0 to 6 MPH).

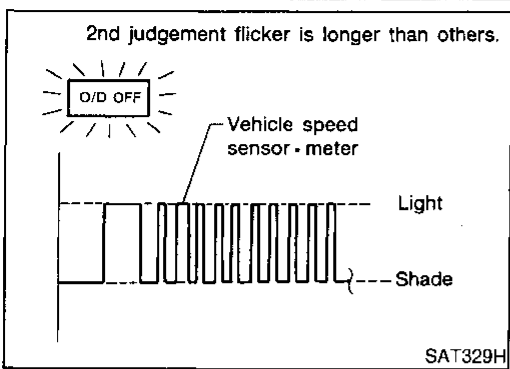

No Tools

- 1) Start engine.
- 2) Drive vehicle under the following conditions:
Selector lever in "D" position and vehicle speed higher than 25 km/h (16 MPH).
- 3) Perform self-diagnosis.
Refer to TCM SELF-DIAGNOSTIC PROCEDURE (No Tools), AT-44.

GI

MA

EM

LC

EC

FE

CL

MT

AT

TF

PD

AX

SU

BR

ST

RS

BT

HA

SC

EL

IDX

VEHICLE SPEED SENSOR·MTR

Wiring Diagram — AT — VSSMTR

Wiring Diagram — AT — VSSMTR

NAAT0202

AT-VSSMTR-01

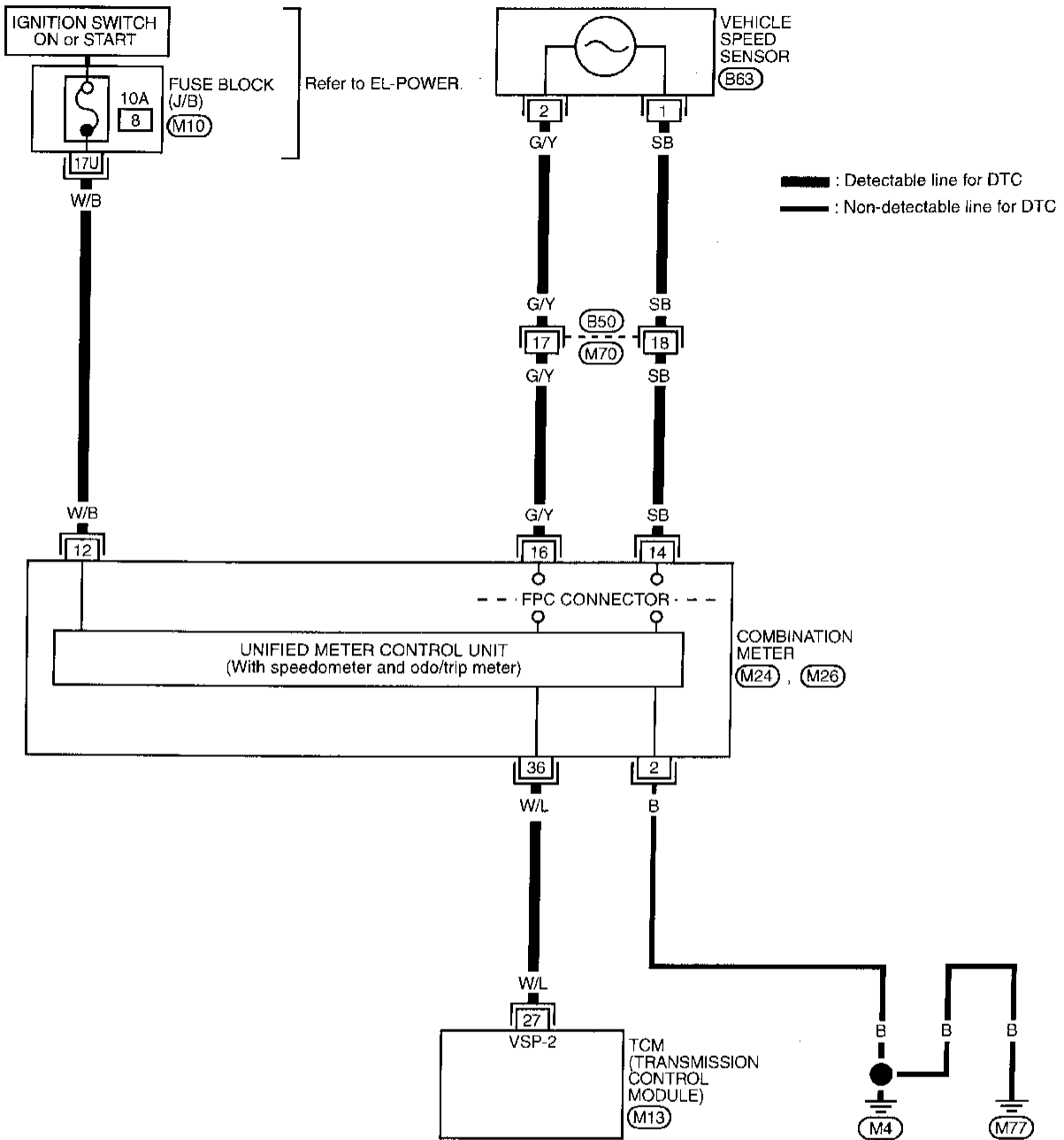

Refer to last page (Foldout page).

(M10)

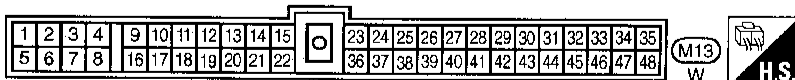
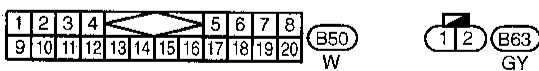
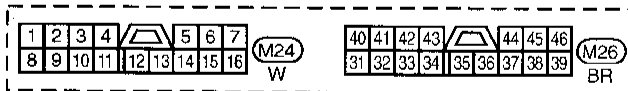

Diagnostic Procedure

NAAT0072

GI

MA

EM

LC

EC

FE

CL

MT

AT

TF

PD

AX

SU

BR

ST

RS

BT

HA

SC

EL

IDX

1	CHECK INPUT SIGNAL.
<p>Ⓜ With CONSULT</p> <ol style="list-style-type: none"> 1. Start engine. 2. Select "ECU INPUT SIGNALS" in "DATA MONITOR" mode for "A/T" with CONSULT. 3. Read out the value of "VHCL/S SE-MTR" while driving. Check the value changes according to driving speed. <div style="border: 1px solid black; padding: 5px; margin: 10px 0;"> <p>☆MONITOR ☆NO FAIL ▼</p> <p>VHCL/S SE-A/T 0km/h</p> <p>VHCL/S SE-MTR 5km/h</p> <p>THRTL POS SEN 0.4V</p> <p>FLUID TEMP SE 1.2V</p> <p>BATTERY VOLT 13.4V</p> <p>ENGINE SPEED 1024rpm</p> <p>OVERDRIVE SW O N</p> <p>P/N POSI SW O N</p> <p>R POSITION SW OFF</p> </div> <div style="border: 1px solid black; padding: 5px; margin: 10px 0; text-align: center;"> <p>RECORD</p> </div> <p style="text-align: right; margin-top: 10px;">SAT076H</p>	
<p>ⓧ Without CONSULT</p> <ol style="list-style-type: none"> 1. Start engine. 2. Check voltage between TCM terminal 27 and ground while driving at 2 to 3 km/h (1 to 2 MPH) for 1 m (3 ft) or more. <div style="text-align: center; margin: 10px 0;"> <p>The diagram shows a voltmeter (V) connected to terminal 27 of the TCM and ground. A label 'W/L' is near the ground connection. Above the TCM are icons for 'H.S.', 'CONNECT', and 'ST'.</p> </div> <p style="text-align: right; margin-top: 10px;">SAT080J</p>	
<p>Does battery voltage vary between less than 1V and more than 4.5V?</p>	
Yes	▶ GO TO 2.
No	▶ Check the following items: <ul style="list-style-type: none"> ● Vehicle speed sensor and ground circuit for vehicle speed sensor Refer to EL section ("METERS AND GAUGES"). ● Harness for short or open between TCM and vehicle speed sensor (Main harness)

2	CHECK DTC
<p>Perform Diagnostic Trouble Code (DTC) confirmation procedure, AT-178.</p>	
OK or NG	
OK	▶ INSPECTION END
NG	▶ <ol style="list-style-type: none"> 1. Perform TCM input/output signal inspection. 2. If NG, recheck TCM pin terminals for damage or loose connection with harness connector.

TROUBLE DIAGNOSES FOR SYMPTOMS

Wiring Diagram — AT — NONDTC

Wiring Diagram — AT — NONDTC

NAAT0203

AT-NONDTC-01

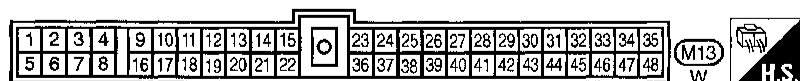
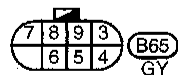
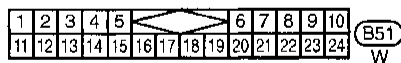
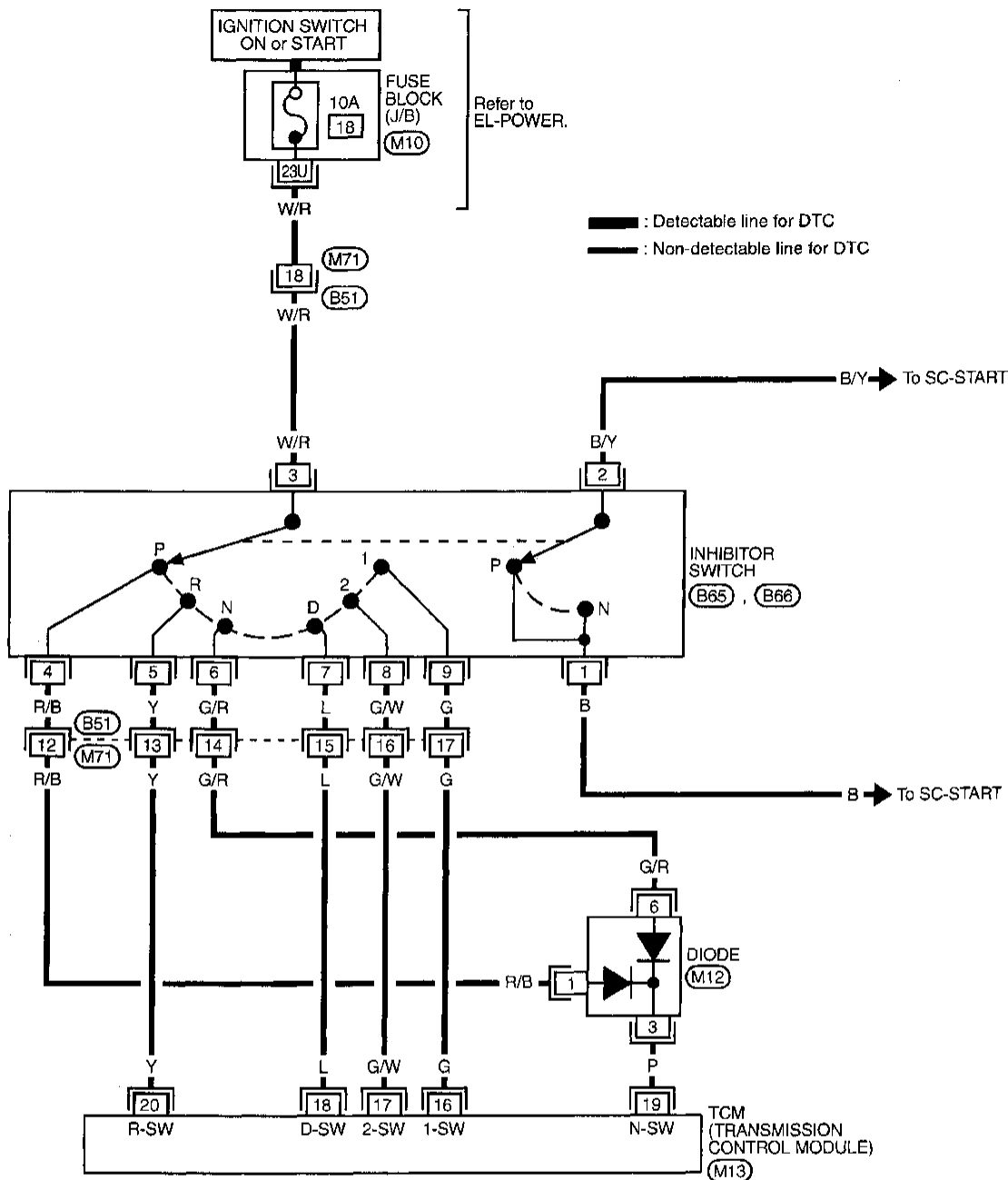

Refer to last page (Foldout page).

(M10)

TROUBLE DIAGNOSES FOR SYMPTOMS

Wiring Diagram — AT — NONDTC (Cont'd)

AT-NONDTC-02

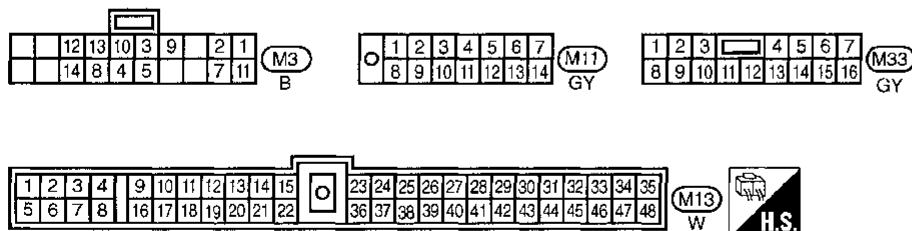
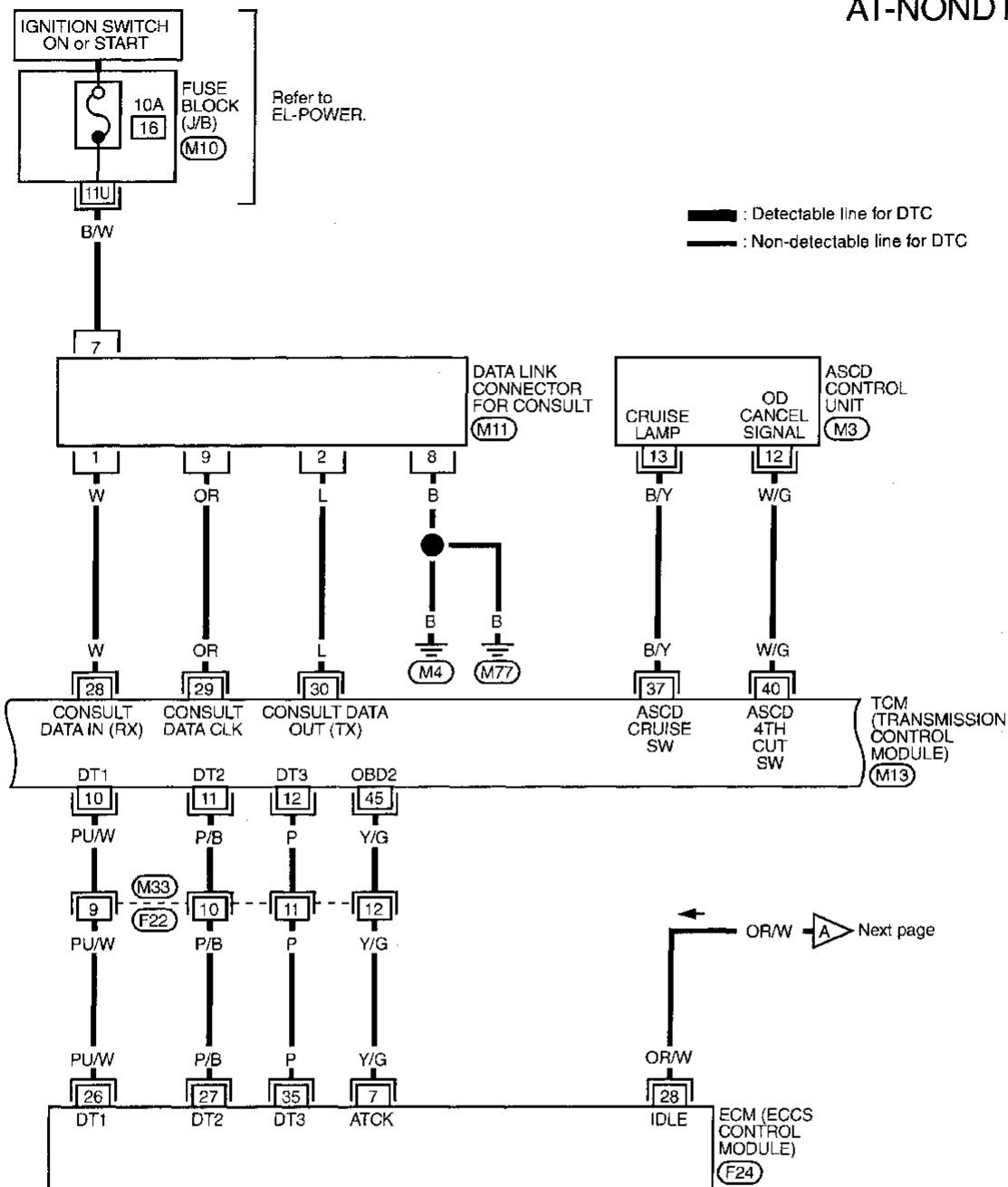

MAT572A

TROUBLE DIAGNOSES FOR SYMPTOMS

Wiring Diagram — AT — NONDTC (Cont'd)

AT-NONDTC-03

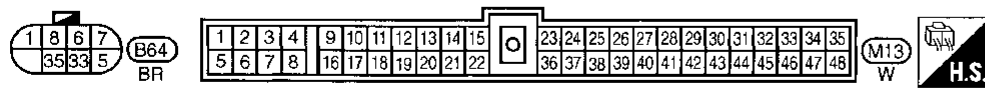
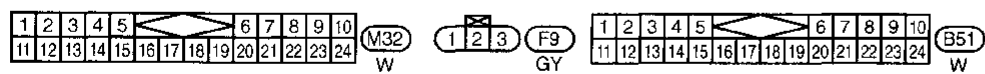
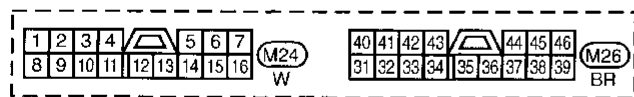
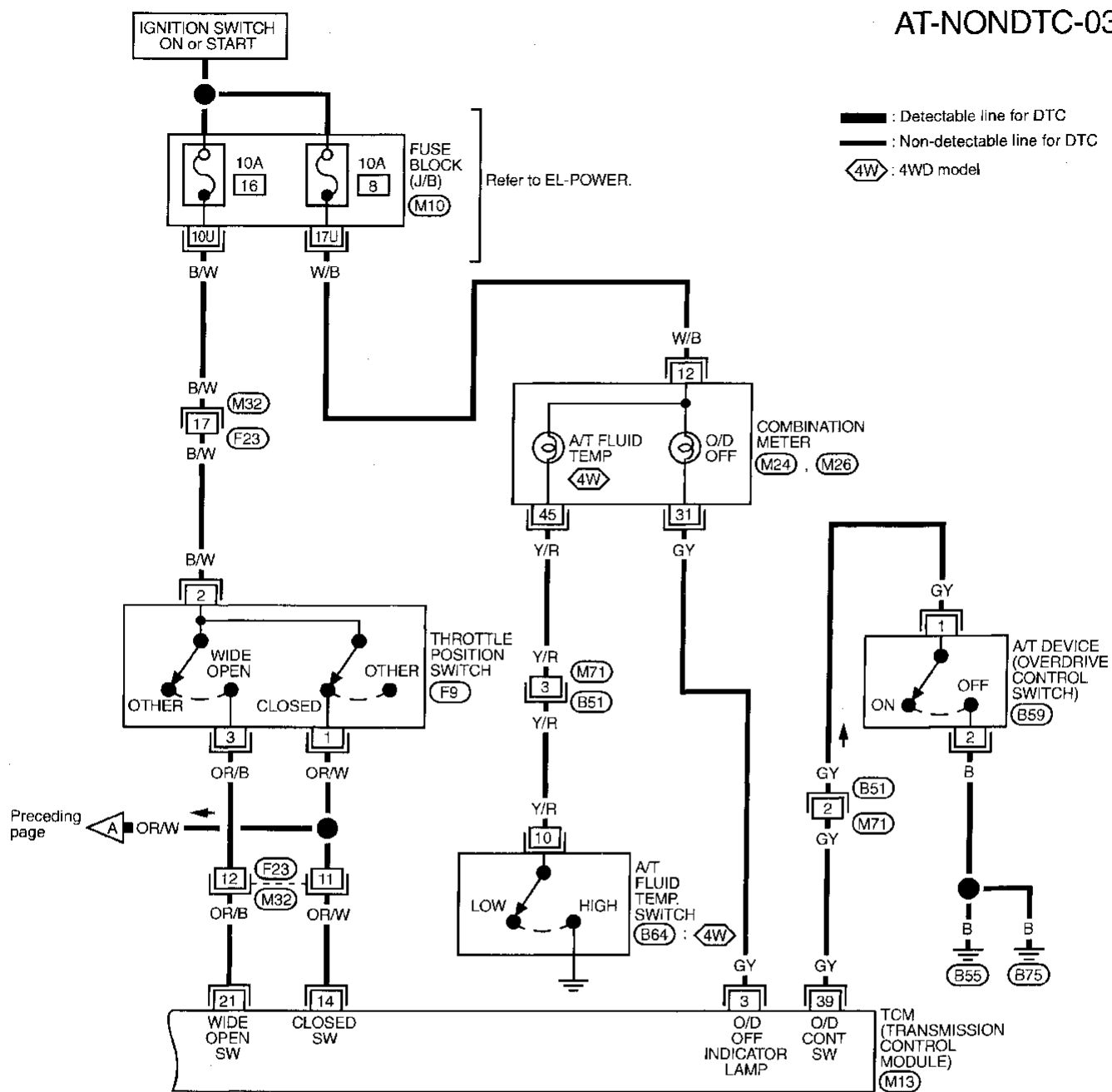

MAT573A

TROUBLE DIAGNOSES FOR SYMPTOMS

1. O/D OFF Indicator Lamp Does Not Come On

1. O/D OFF Indicator Lamp Does Not Come On

NAAT0073

SYMPTOM:

O/D OFF indicator lamp does not come on for about 2 seconds when turning ignition switch to "ON".

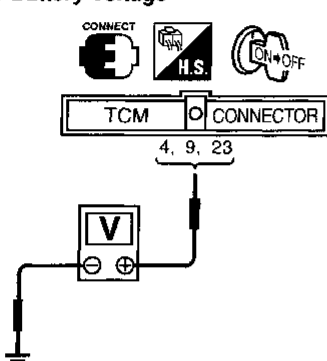
1	CHECK TCM POWER SOURCE
<p>1. Turn ignition switch to "ON" position. (Do not start engine.)</p> <p>2. Check voltage between TCM terminals 4, 9, 23 and ground. Voltage: Battery voltage</p>  <p style="text-align: right;">SAT909I</p> <p>3. Turn ignition switch to "OFF" position.</p> <p>4. Check voltage between TCM terminal 23 and ground. Voltage: Battery voltage</p> <p style="text-align: center;">OK or NG</p>	
OK	▶ GO TO 2.
NG	▶ Check the following items: <ul style="list-style-type: none"> • Harness for short or open between ignition switch and TCM (Main harness) • Refer to "Wiring Diagram — AT — MAIN", AT-84. • Ignition switch and fuse Refer to EL section ("POWER SUPPLY ROUTING").

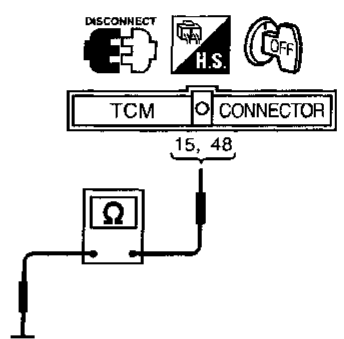
2	CHECK TCM GROUND CIRCUIT
<p>1. Turn ignition switch to "OFF" position.</p> <p>2. Disconnect TCM harness connector.</p> <p>3. Check resistance between TCM terminals 15, 48 and ground.</p>  <p style="text-align: right;">SAT910I</p> <p>If OK, check harness for short to ground and short to power.</p> <p style="text-align: center;">Is resistance approx. 0Ω?</p>	
Yes	▶ GO TO 3.
No	▶ <ul style="list-style-type: none"> • Repair open circuit or short to ground or short to power in harness or connectors. • Refer to "Wiring Diagram — AT — MAIN", AT-84.

TROUBLE DIAGNOSES FOR SYMPTOMS

1. O/D OFF Indicator Lamp Does Not Come On (Cont'd)

3	CHECK LAMP CIRCUIT
	<p>1. Turn ignition switch to "ON" position. 2. Set overdrive control switch to "ON" position. 3. Check voltage between TCM terminals 3 and ground.</p> <div style="text-align: center;"> </div> <p style="text-align: right;">SAT103J</p> <p style="text-align: center;">Does battery voltage exist?</p>
Yes	▶ GO TO 4.
No	<p style="text-align: center;">▶ Check the following items.</p> <ul style="list-style-type: none"> ● Fuse ● O/D OFF indicator lamp Refer to EL section ("WARNING LAMPS"). ● Harness for short or open between ignition switch and O/D OFF indicator lamp (Main harness) ● Refer to EL section ("POWER SUPPLY ROUTING"). ● Harness for short or open between O/D OFF indicator lamp and TCM

4	CHECK SYMPTOM
	<p>Check again.</p> <p style="text-align: center;">OK or NG</p>
OK	▶ INSPECTION END
NG	<p style="text-align: center;">▶</p> <ol style="list-style-type: none"> 1. Perform TCM input/output signal inspection. 2. If NG, recheck TCM pin terminals for damage or loose connection with harness connector.

TROUBLE DIAGNOSES FOR SYMPTOMS

2. Engine Cannot Be Started In "P" and "N" Position

2. Engine Cannot Be Started In "P" and "N" Position

=NAAT0074

SYMPTOM:

Engine cannot be started with selector lever in "P" or "N" position.

Engine cannot be started with selector lever in "P" Engine can be started with selector lever in "D", "2", "1" or "R" position.

1 CHECK INHIBITOR SWITCH CIRCUIT	
<p><input type="checkbox"/> With CONSULT Does "ECU INPUT SIGNALS" in Data Monitor show damage to inhibitor switch circuit?</p>	
<p><input checked="" type="checkbox"/> Without CONSULT Does self-diagnosis show damage to inhibitor switch circuit?</p>	
SAT344H	
Yes or No	
Yes	▶ Check inhibitor switch circuit. Refer to "DTC P0705", AT-86.
No	▶ GO TO 2.

2 CHECK INHIBITOR SWITCH INSPECTION	
<p>Check for short or open of inhibitor switch 2-pin connector. Refer to "Components Inspection", AT-90.</p>	
SAT838B	
OK or NG	
OK	▶ GO TO 3.
NG	▶ Repair or replace inhibitor switch.

3 CHECK STARTING SYSTEM	
<p>Check starting system. Refer to EL section ("System Description", "STARTING SYSTEM").</p>	
OK or NG	
OK	▶ INSPECTION END
NG	▶ Repair or replace damaged parts.

TROUBLE DIAGNOSES FOR SYMPTOMS

3. In "P" Position, Vehicle Moves Forward Or Backward When Pushed

3. In "P" Position, Vehicle Moves Forward Or Backward When Pushed

=NAAT0075

SYMPTOM:

Vehicle moves when it is pushed forward or backward with selector lever in "P" position.

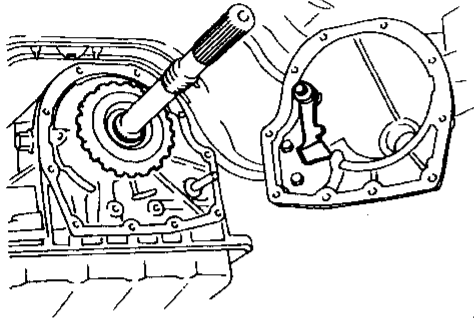
1	CHECK PARKING COMPONENTS
Check parking components. Refer to "Parking Pawl Components", AT-286.	
 <p data-bbox="665 777 755 808">SAT133B</p>	
OK or NG	
OK	▶ INSPECTION END
NG	▶ Repair or replace damaged parts.

TROUBLE DIAGNOSES FOR SYMPTOMS

4. In "N" Position, Vehicle Moves

=NAAT0076

4. In "N" Position, Vehicle Moves

SYMPTOM:

Vehicle moves forward or backward when selecting "N" position.

1	CHECK INHIBITOR SWITCH CIRCUIT
<p> With CONSULT Does "ECU INPUT SIGNALS" in Data Monitor show damage to inhibitor switch circuit?</p>	
<p> Without CONSULT Does self-diagnosis show damage to inhibitor switch circuit?</p>	
Yes or No	
Yes	▶ Check inhibitor switch circuit. Refer to "DTC P0705", AT-86.
No	▶ GO TO 2.

2	CHECK CONTROL LINKAGE
Check control linkage. Refer to AT-227.	
<p>"P" position</p>	
OK or NG	
OK	▶ GO TO 3.
NG	▶ Adjust control linkage. Refer to AT-227.

3	CHECK A/T FLUID LEVEL
Check A/T fluid level again.	
OK or NG	
OK	▶ GO TO 4.
NG	▶ Refill ATF.

4	CHECK A/T FLUID CONDITION
<p>1. Remove oil pan. 2. Check A/T fluid condition.</p>	
OK or NG	
OK	▶ GO TO 5.
NG	▶ <ul style="list-style-type: none"> 1. Disassemble A/T. 2. Check the following items: <ul style="list-style-type: none"> ● Forward clutch assembly ● Overrun clutch assembly ● Reverse clutch assembly

TROUBLE DIAGNOSES FOR SYMPTOMS

4. In "N" Position, Vehicle Moves (Cont'd)

5	CHECK SYMPTOM	
Check again.		
OK or NG		
OK	▶	INSPECTION END
NG	▶	<ol style="list-style-type: none">1. Perform TCM input/output signal inspection.2. If NG, recheck TCM pin terminals for damage or loose connection with harness connector.

TROUBLE DIAGNOSES FOR SYMPTOMS

5. Large Shock. "N" → "R" Position

5. Large Shock. "N" → "R" Position

-NAAT0077

SYMPTOM:

There is large shock when changing from "N" to "R" position.

1	CHECK SELF-DIAGNOSTIC RESULTS
Does self-diagnosis show damage to A/T fluid temperature sensor, line pressure solenoid valve or throttle position sensor circuit?	
<p style="text-align: right;">SAT345HA</p>	
Yes or No	
Yes	▶ Check damaged circuit. Refer to "DTC P0710, DTC P0745 or DTC P1705", AT-94, 148 or 165.
No	▶ GO TO 2.

2	CHECK THROTTLE POSITION SENSOR
Check throttle position sensor. Refer to EC section ("DTC P0120 THROTTLE POSITION SENSOR").	
<p style="text-align: right;">SAT329I</p>	
OK or NG	
OK	▶ GO TO 3.
NG	▶ Repair or replace throttle position sensor.

3	CHECK LINE PRESSURE
Check line pressure at idle with selector lever in "D" position. Refer to "LINE PRESSURE TEST", AT-57.	
<p style="text-align: right;">SAT494G</p>	
OK or NG	
OK	▶ GO TO 4.
NG	▶ <ol style="list-style-type: none"> 1. Remove control valve assembly. Refer to AT-225. 2. Check the following items: <ul style="list-style-type: none"> • Valves to control line pressure (Pressure regulator valve, pressure modifier valve, pilot valve and pilot filter) • Line pressure solenoid valve

4	CHECK SYMPTOM
Check again.	
OK or NG	
OK	▶ INSPECTION END
NG	▶ <ol style="list-style-type: none"> 1. Perform TCM input/output signal inspection. 2. If NG, recheck TCM pin terminals for damage or loose connection with harness connector.

TROUBLE DIAGNOSES FOR SYMPTOMS

6. Vehicle Does Not Creep Backward In "R" Position

6. Vehicle Does Not Creep Backward In "R" Position

=NAAT0078

SYMPTOM:

Vehicle does not creep backward when selecting "R" position.

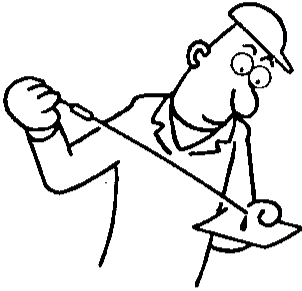
1	CHECK A/T FLUID LEVEL
Check A/T fluid level again.	
	
SAT638A	
OK or NG	
OK	▶ GO TO 2.
NG	▶ Refill ATF.

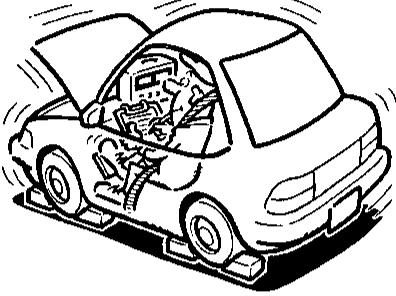
2	CHECK STALL TEST
Check stall revolution with selector lever in "1" and "R" positions. Refer to AT-307.	
	
SAT493G	
OK or NG	
OK	▶ GO TO 3.
OK in "1" position, NG in "R" position	▶ <ul style="list-style-type: none"> 1. Remove control valve assembly. Refer to "ON-VEHICLE SERVICE", AT-225. 2. Check the following items: <ul style="list-style-type: none"> ● Valves to control line pressure (Pressure regulator valve, pressure modifier valve, pilot valve and pilot filter) ● Line pressure solenoid valve 3. Disassemble A/T. 4. Check the following items: <ul style="list-style-type: none"> ● Oil pump assembly ● Torque converter ● Reverse clutch assembly ● High clutch assembly
NG in both "1" and "R" positions	▶ GO TO 6.

TROUBLE DIAGNOSES FOR SYMPTOMS

6. Vehicle Does Not Creep Backward In "R" Position (Cont'd)

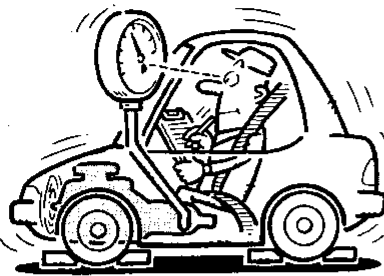
3	CHECK LINE PRESSURE
<p>Check line pressure at idle with selector lever in "R" position. Refer to "LINE PRESSURE TEST", AT-57.</p>	
	
SAT494G	
OK or NG	
OK	▶ GO TO 4.
NG	▶ <ol style="list-style-type: none"> 1. Remove control valve assembly. Refer to "ON-VEHICLE SERVICE", AT-225. 2. Check the following items: <ul style="list-style-type: none"> ● Valves to control line pressure (Pressure regulator valve, pressure modifier valve, pilot valve and pilot filter) ● Line pressure solenoid valve 3. Disassemble A/T. 4. Check the following items: <ul style="list-style-type: none"> ● Oil pump assembly

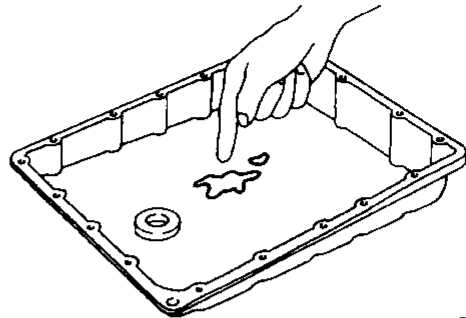
4	CHECK A/T FLUID CONDITION
<ol style="list-style-type: none"> 1. Remove oil pan. 2. Check A/T fluid condition. 	
	
SAT171B	
OK or NG	
OK	▶ GO TO 5.
NG	▶ GO TO 6.

5	CHECK SYMPTOM
Check again.	
OK or NG	
OK	▶ INSPECTION END
NG	▶ <ol style="list-style-type: none"> 1. Perform TCM input/output signal inspection. 2. If NG, recheck TCM pin terminals for damage or loose connection with harness connector.

6	DETECT MALFUNCTIONING ITEM
<ol style="list-style-type: none"> 1. Remove control valve assembly. Refer to "ON-VEHICLE SERVICE", AT-225. 2. Check the following items: <ul style="list-style-type: none"> ● Valves to control line pressure (Pressure regulator valve, pressure modifier valve, pilot valve and pilot filter) ● Line pressure solenoid valve 3. Disassemble A/T. 4. Check the following items: <ul style="list-style-type: none"> ● Oil pump assembly ● Torque converter ● Reverse clutch assembly ● High clutch assembly ● Low & reverse brake assembly ● Low one-way clutch 	
▶ Repair or replace damaged parts.	

GI
MA
EM
LC
EC
FE
CL
MT
AT
TF
PD
AX
SU
BR
ST
RS
BT
HA
SC
EL
DX

TROUBLE DIAGNOSES FOR SYMPTOMS

7. Vehicle Does Not Creep Forward In "D", "2" Or "1" Position

7. Vehicle Does Not Creep Forward In "D", "2" Or "1" Position

-NAAT0079

SYMPTOM:

Vehicle does not creep forward when selecting "D", "2" or "1" position.

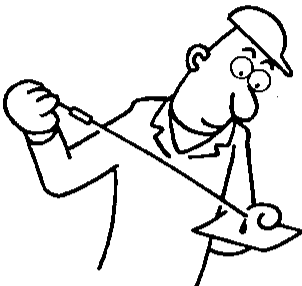
1	CHECK A/T FLUID LEVEL
Check A/T fluid level again.	
	
SAT638A	
OK or NG	
OK	▶ GO TO 2.
NG	▶ Refill ATF.

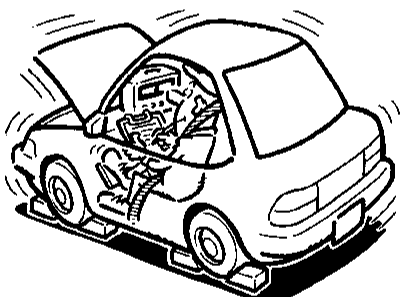
2	CHECK STALL TEST
Check stall revolution with selector lever in "D" position. Refer to "STALL TEST", AT-54.	
	
SAT493G	
OK or NG	
OK	▶ GO TO 3.
NG	▶ GO TO 6.

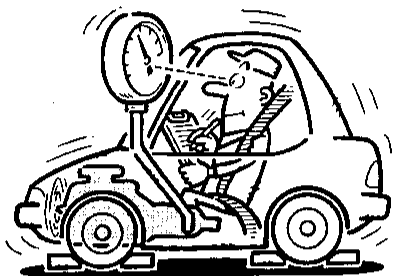
3	CHECK LINE PRESSURE
Check line pressure at idle with selector lever in "R" position. Refer to "LINE PRESSURE TEST", AT-57.	
	
SAT494G	
OK or NG	
OK	▶ GO TO 4.
NG	▶ <ol style="list-style-type: none"> 1. Remove control valve assembly. Refer to AT-225. 2. Check the following items: <ul style="list-style-type: none"> • Valves to control line pressure (Pressure regulator valve, pressure modifier valve, pilot valve and pilot filter) • Line pressure solenoid valve 3. Disassemble A/T. 4. Check the following items: <ul style="list-style-type: none"> • Oil pump assembly

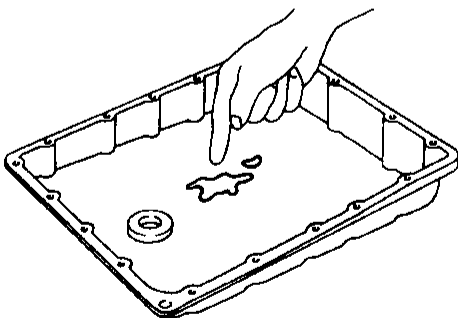
4	CHECK A/T FLUID CONDITION
<ol style="list-style-type: none"> 1. Remove oil pan. 2. Check A/T fluid condition. 	
	
SAT171B	
OK or NG	
OK	▶ GO TO 5.
NG	▶ GO TO 6.

TROUBLE DIAGNOSES FOR SYMPTOMS

7. Vehicle Does Not Creep Forward In "D", "2" Or "1" Position (Cont'd)

5	CHECK SYMPTOM	
Check again.		
OK or NG		
OK	▶	INSPECTION END
NG	▶	<ol style="list-style-type: none"> 1. Perform TCM input/output signal inspection. 2. If NG, recheck TCM pin terminals for damage or loose connection with harness connector.

6	DETECT MALFUNCTIONING ITEM	
<ol style="list-style-type: none"> 1. Remove control valve assembly. Refer to "ON-VEHICLE SERVICE", AT-225. 2. Check the following items: <ul style="list-style-type: none"> ● Valves to control line pressure (Pressure regulator valve, pressure modifier valve, pilot valve and pilot filter) ● Line pressure solenoid valve 3. Disassemble A/T. 4. Check the following items: <ul style="list-style-type: none"> ● Oil pump assembly ● Forward clutch assembly ● Forward one-way clutch ● Low one-way clutch ● Low & reverse brake assembly ● Torque converter 		
▶		Repair or replace damaged parts.

GI
 MA
 EM
 LC
 EC
 FE
 CL
 MT
AT
 TF
 PD
 AX
 SU
 BR
 ST
 RS
 BT
 HA
 SC
 EL
 IDX

TROUBLE DIAGNOSES FOR SYMPTOMS

8. Vehicle Cannot Be Started From D₁

=NAAT0080

8. Vehicle Cannot Be Started From D₁

SYMPTOM:

Vehicle cannot be started from D₁ on Cruise test — Part 1.

1	CHECK SYMPTOM	
Is "6. Vehicle Does Not Creep Backward In "R" Position" OK?		
Yes or No		
Yes	▶	GO TO 2.
No	▶	Go to "6. Vehicle Does Not Creep Backward In "R" Position", AT-192.

2	CHECK SELF-DIAGNOSTIC RESULTS	
Does self-diagnosis show damage to vehicle speed sensor-A/T (revolution sensor), shift solenoid valve A, B or vehicle speed sensor-MTR after cruise test?		
<p style="text-align: right;">SAT934FB</p>		
Yes or No		
Yes	▶	Check damaged circuit. Refer to "DTC P0720, DTC P0750, DTC P0755 or VEHICLE SPEED SENSOR. MTR", AT-99, 154, 159 or 181.
No	▶	GO TO 3.

3	CHECK THROTTLE POSITION SENSOR	
Check throttle position sensor. Refer to EC section ("DTC P0120 THROTTLE POSITION SENSOR").		
<p style="text-align: right;">SAT329F</p>		
OK or NG		
OK	▶	GO TO 4.
NG	▶	Repair or replace throttle position sensor.

4	CHECK LINE PRESSURE	
Check line pressure at stall point with selector lever in "D" position. Refer to "LINE PRESSURE TEST", AT-57.		
<p style="text-align: right;">SAT494G</p>		
OK or NG		
OK	▶	GO TO 5.
NG	▶	GO TO 8.

5	CHECK A/T FLUID CONDITION	
<ol style="list-style-type: none"> 1. Remove oil pan. 2. Check A/T fluid condition. 		
<p style="text-align: right;">SAT171B</p>		
OK or NG		
OK	▶	GO TO 6.
NG	▶	GO TO 8.

TROUBLE DIAGNOSES FOR SYMPTOMS

8. Vehicle Cannot Be Started From D, (Cont'd)

6	DETECT MALFUNCTIONING ITEM	
1. Remove control valve assembly. Refer to AT-225. 2. Check the following items: <ul style="list-style-type: none"> ● Shift valve A ● Shift valve B ● Shift solenoid valve A ● Shift solenoid valve B ● Pilot valve ● Pilot filter 		
OK or NG		
OK	▶	GO TO 7.
NG	▶	Repair or replace damaged parts.

7	CHECK SYMPTOM	
Check again.		
OK or NG		
OK	▶	INSPECTION END
NG	▶	1. Perform TCM input/output signal inspection. 2. If NG, recheck TCM pin terminals for damage or loose connection with harness connector.

8	DETECT MALFUNCTIONING ITEM	
1. Remove control valve assembly. Refer to AT-225. 2. Check the following items: <ul style="list-style-type: none"> ● Shift valve A ● Shift valve B ● Shift solenoid valve A ● Shift solenoid valve B ● Pilot valve ● Pilot filter 3. Disassemble A/T. 4. Check the following items: <ul style="list-style-type: none"> ● Forward clutch assembly ● Forward one-way clutch ● Low one-way clutch ● High clutch assembly ● Torque converter ● Oil pump assembly 		
OK or NG		
OK	▶	GO TO 7.
NG	▶	Repair or replace damaged parts.

GI
 MA
 EM
 LC
 EC
 FE
 CL
 MT
 AT
 TF
 PD
 AX
 SU
 BR
 ST
 RS
 BT
 HA
 SC
 EL
 DX

TROUBLE DIAGNOSES FOR SYMPTOMS

9. A/T Does Not Shift: $D_1 \rightarrow D_2$ Or Does Not Kickdown: $D_4 \rightarrow D_2$

9. A/T Does Not Shift: $D_1 \rightarrow D_2$ Or Does Not Kickdown: $D_4 \rightarrow D_2$

=NAAT0081

SYMPTOM:

A/T does not shift from D_1 to D_2 at the specified speed.
A/T does not shift from D_4 to D_2 when depressing accelerator pedal fully at the specified speed.

1	CHECK SYMPTOM	
Are "7. Vehicle Does Not Creep Forward In "D", "2" Or "1" Position" and "8. Vehicle Cannot Be Started From D_1 ," OK?		
Yes or No		
Yes	▶	GO TO 2.
No	▶	Go to "7. Vehicle Does Not Creep Forward In "D", "2" Or "1" Position" and "8. Vehicle Cannot Be Started From D_1 ," AT-194, 196.

2	CHECK INHIBITOR SWITCH CIRCUIT	
<input type="checkbox"/> With CONSULT Does "ECU INPUT SIGNALS" in Data Monitor show damage to inhibitor switch circuit?		
<input checked="" type="checkbox"/> Without CONSULT Does self-diagnosis show damage to inhibitor switch circuit?		
SAT344H		
Yes or No		
Yes	▶	Check inhibitor switch circuit. Refer to "DTC P0705", AT-89.
No	▶	GO TO 3.

3	CHECK VEHICLE SPEED SENSOR-A/T AND VEHICLE SPEED SENSOR-MTR CIRCUIT	
Check vehicle speed sensor-A/T (revolution sensor) and vehicle speed sensor-MTR circuit. Refer to "DTC P0720 and VEHICLE SPEED SENSOR-MTR", AT-99, 181.		
OK or NG		
OK	▶	GO TO 4.
NG	▶	Repair or replace vehicle speed sensor-A/T (revolution sensor) and vehicle speed sensor-MTR circuits.

4	CHECK THROTTLE POSITION SENSOR	
Check throttle position sensor. Refer to EC section ("DTC P0120 THROTTLE POSITION SENSOR").		
OK or NG		
OK	▶	GO TO 5.
NG	▶	Repair or replace throttle position sensor.

5	CHECK A/T FLUID CONDITION	
1. Remove oil pan. 2. Check A/T fluid condition.		
OK or NG		
OK	▶	GO TO 6.
NG	▶	GO TO 8.

TROUBLE DIAGNOSES FOR SYMPTOMS

9. A/T Does Not Shift: D₁ → D₂ Or Does Not Kickdown: D₄ → D₂ (Cont'd)

6	DETECT MALFUNCTIONING ITEM	
1. Remove control valve. Refer to AT-225. 2. Check the following items: <ul style="list-style-type: none"> ● Shift valve A ● Shift solenoid valve A ● Pilot valve ● Pilot filter 		
OK or NG		
OK	▶	GO TO 7.
NG	▶	Repair or replace damaged parts.

7	CHECK SYMPTOM	
Check again.		
OK or NG		
OK	▶	INSPECTION END
NG	▶	1. Perform TCM input/output signal inspection. 2. If NG, recheck TCM pin terminals for damage or loose connection with harness connector.

8	DETECT MALFUNCTIONING ITEM	
1. Remove control valve. Refer to AT-225. 2. Check the following items: <ul style="list-style-type: none"> ● Shift valve A ● Shift solenoid valve A ● Pilot valve ● Pilot filter 3. Disassemble A/T. 4. Check the following items: <ul style="list-style-type: none"> ● Servo piston assembly ● Brake band ● Oil pump assembly 		
OK or NG		
OK	▶	GO TO 7.
NG	▶	Repair or replace damaged parts.

GI
 MA
 EM
 LG
 EC
 FE
 CL
 MT
AT
 TF
 PD
 AX
 SU
 BR
 ST
 RS
 BT
 HA
 SC
 EL
 IDX

TROUBLE DIAGNOSES FOR SYMPTOMS

10. A/T Does Not Shift: $D_2 \rightarrow D_3$



10. A/T Does Not Shift: $D_2 \rightarrow D_3$

=NAAT00B2

SYMPTOM:

A/T does not shift from D_2 to D_3 at the specified speed.

1	CHECK SYMPTOM
Are "7. Vehicle Does Not Creep Forward In "D", "2" Or "1" Position" and "8. Vehicle Cannot Be Started From D_1 ," OK?	
Yes or No	
Yes	▶ GO TO 2.
No	▶ Go to "7. Vehicle Does Not Creep Forward In "D", "2" Or "1" Position" and "8. Vehicle Cannot Be Started From D_1 ," AT-194, 196.

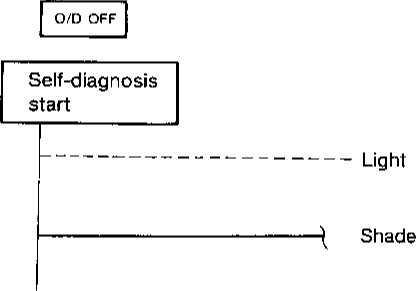
2	CHECK INHIBITOR SWITCH CIRCUIT
<p> With CONSULT Does "ECU INPUT SIGNALS" in Data Monitor show damage to inhibitor switch circuit?</p>	
<p> Without CONSULT Does self-diagnosis show damage to inhibitor switch circuit?</p>	
	
SAT344H	
Yes or No	
Yes	▶ Check inhibitor switch circuit. Refer to "DTC P0705", AT-89.
No	▶ GO TO 3.

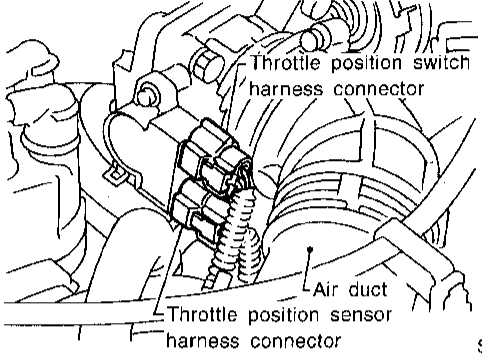
3	CHECK THROTTLE POSITION SENSOR
Check throttle position sensor. Refer to EC section ("DTC P0120 THROTTLE POSITION SENSOR").	
	
SAT329I	
OK or NG	
OK	▶ GO TO 4.
NG	▶ Repair or replace throttle position sensor.

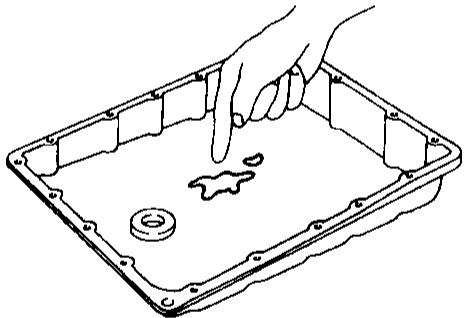
4	CHECK A/T FLUID CONDITION
<ol style="list-style-type: none"> 1. Remove oil pan. 2. Check A/T fluid condition. 	
	
SAT171B	
OK or NG	
OK	▶ GO TO 5.
NG	▶ GO TO 7.

5	DETECT MALFUNCTIONING ITEM
<ol style="list-style-type: none"> 1. Remove control valve Assembly. Refer to AT-225. 2. Check the following items: <ul style="list-style-type: none"> ● Shift valve B ● Shift solenoid valve B ● Pilot valve ● Pilot filter 	
OK or NG	
OK	▶ GO TO 6.
NG	▶ Repair or replace damaged parts.

TROUBLE DIAGNOSES FOR SYMPTOMS

10. A/T Does Not Shift: D₂ → D₃ (Cont'd)

6	CHECK SYMPTOM	
Check again.		
OK or NG		
OK	▶	INSPECTION END
NG	▶	1. Perform TCM input/output signal inspection. 2. If NG, recheck TCM pin terminals for damage or loose connection with harness connector.

7	DETECT MALFUNCTIONING ITEM	
1. Remove control valve Assembly. Refer to AT-225. 2. Check the following items: <ul style="list-style-type: none"> ● Shift valve B ● Shift solenoid valve B ● Pilot valve ● Pilot filter 3. Disassemble A/T. 4. Check the following items: <ul style="list-style-type: none"> ● Servo piston assembly ● High clutch assembly ● Oil pump assembly 		
OK or NG		
OK	▶	GO TO 6.
NG	▶	Repair or replace damaged parts.

GI
MA
EM
LC
EC
FE
CL
MT
AT
TF
PD
AX
SU
BR
ST
RS
BT
HA
SC
EL
DX

TROUBLE DIAGNOSES FOR SYMPTOMS

11. A/T Does Not Shift: $D_3 \rightarrow D_4$

=NAAT0083

11. A/T Does Not Shift: $D_3 \rightarrow D_4$

SYMPTOM:

- A/T does not shift from D_3 to D_4 at the specified speed.
- A/T must be warm before D_3 to D_4 shift will occur.

1 CHECK SYMPTOM	
Are "7. Vehicle Does Not Creep Forward In "D", "2" Or "1" Position" and "8. Vehicle Cannot Be Started From D_1 ," OK?	
Yes or No	
Yes	▶ GO TO 2.
No	▶ Go to "7. Vehicle Does Not Creep Forward In "D", "2" Or "1" Position" and "8. Vehicle Cannot Be Started From D_1 ," AT-194, 196.

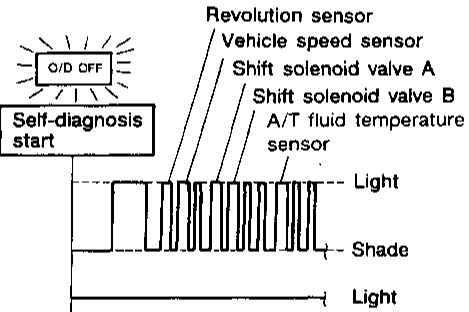
2 CHECK SELF-DIAGNOSTIC RESULTS	
<p> With CONSULT Does self-diagnosis, after cruise test, show damage to any of the following circuits?</p> <ul style="list-style-type: none"> • Inhibitor switch • Overdrive control switch • A/T fluid temperature sensor • Revolution sensor • Shift solenoid valve A or B • Vehicle speed sensor 	
 <p style="text-align: right;">SAT363HA</p>	
Yes or No	
Yes	▶ Check damaged circuit. Refer to "DTC P0705, P0710, P0720, P0750, P0755 or VHCL SPEED SEN-MTR", AT-89, 94, 99, 154, 159 or 181.
No	▶ GO TO 3.

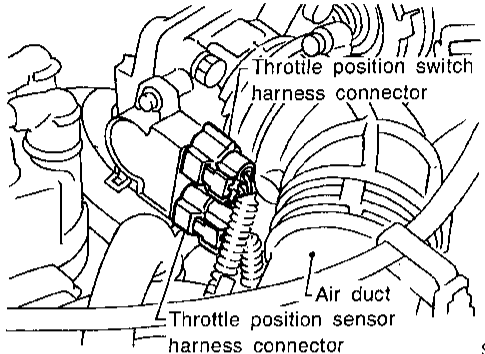
3 CHECK THROTTLE POSITION SENSOR	
Check throttle position sensor. Refer to EC section ("DTC P0120 THROTTLE POSITION SENSOR").	
 <p style="text-align: right;">SAT329I</p>	
OK or NG	
OK	▶ GO TO 4.
NG	▶ Repair or replace throttle position sensor.

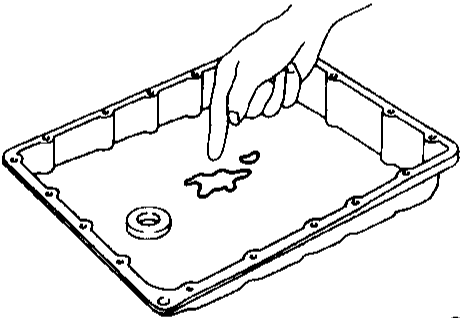
4 CHECK A/T FLUID CONDITION	
<ol style="list-style-type: none"> 1. Remove oil pan. 2. Check A/T fluid condition. 	
 <p style="text-align: right;">SAT171B</p>	
OK or NG	
OK	▶ GO TO 5.
NG	▶ GO TO 7.

TROUBLE DIAGNOSES FOR SYMPTOMS

11. A/T Does Not Shift: D₃ → D₄ (Cont'd)

5	DETECT MALFUNCTIONING ITEM	
1. Remove control valve Assembly. Refer to AT-225. 2. Check the following items: <ul style="list-style-type: none"> ● Shift valve B ● Overrun clutch control valve ● Shift solenoid valve B ● Pilot valve ● Pilot filter 		
OK or NG		
OK	▶	GO TO 6.
NG	▶	Repair or replace damaged parts.

6	CHECK SYMPTOM	
Check again.		
OK or NG		
OK	▶	INSPECTION END
NG	▶	1. Perform TCM input/output signal inspection. 2. If NG, recheck TCM pin terminals for damage or loose connection with harness connector.

7	DETECT MALFUNCTIONING ITEM	
1. Remove control valve Assembly. Refer to AT-225. 2. Check the following items: <ul style="list-style-type: none"> ● Shift valve B ● Overrun clutch control valve ● Shift solenoid valve B ● Pilot valve ● Pilot filter 3. Disassemble A/T. 4. Check the following items: <ul style="list-style-type: none"> ● Servo piston assembly ● Brake band ● Torque converter ● Oil pump assembly 		
OK or NG		
OK	▶	GO TO 6.
NG	▶	Repair or replace damaged parts.

GI
 MA
 EM
 LC
 EC
 FE
 GL
 MT
 AT
 TF
 PD
 AX
 SU
 BR
 ST
 RS
 BT
 HA
 SC
 EL
 IDX

TROUBLE DIAGNOSES FOR SYMPTOMS

12. A/T Does Not Perform Lock-up

12. A/T Does Not Perform Lock-up

-NAAT0084

SYMPTOM:

A/T does not perform lock-up at the specified speed.

1	CHECK SELF-DIAGNOSTIC RESULTS
Does self-diagnosis show damage to torque converter clutch solenoid valve circuit after cruise test?	
Yes or No	
Yes	▶ Check torque converter clutch solenoid valve circuit. Refer to "DTC P0740", AT-135.
No	▶ GO TO 2.

3	DETECT MALFUNCTIONING ITEM
<ol style="list-style-type: none"> 1. Remove control valve. Refer to AT-225. 2. Check following items: <ul style="list-style-type: none"> • Torque converter clutch control valve • Torque converter relief valve • Torque converter clutch solenoid valve • Pilot valve • Pilot filter 	
OK or NG	
OK	▶ GO TO 4.
NG	▶ Repair or replace damaged parts.

4	CHECK SYMPTOM
Check again.	
OK or NG	
OK	▶ INSPECTION END
NG	▶ <ol style="list-style-type: none"> 1. Perform TCM input/output signal inspection. 2. If NG, recheck TCM pin terminals for damage or loose connection with harness connector.

2	CHECK THROTTLE POSITION SENSOR
Check throttle position sensor. Refer to EC section ("P0120 THROTTLE POSITION SENSOR").	
OK or NG	
OK	▶ GO TO 3.
NG	▶ Repair or replace throttle position sensor.

TROUBLE DIAGNOSES FOR SYMPTOMS

13. A/T Does Not Hold Lock-up Condition

13. A/T Does Not Hold Lock-up Condition

NAAT0085

SYMPTOM:

A/T does not hold lock-up condition for more than 30 seconds.

1	CHECK DIAGNOSTIC RESULTS
Does self-diagnosis show damage to engine speed signal circuit after cruise test?	
SAT347H	
Yes or No	
Yes	▶ Check engine speed signal circuit. Refer to "DTC P0725", AT-104.
No	▶ GO TO 2.

2	CHECK A/T FLUID CONDITION
<ol style="list-style-type: none"> Remove oil pan. Check A/T fluid condition. 	
SAT171B	
OK or NG	
OK	▶ GO TO 3.
NG	▶ GO TO 5.

3	DETECT MALFUNCTIONING ITEM
<ol style="list-style-type: none"> Remove control valve assembly. Refer to AT-225. Check the following items: <ul style="list-style-type: none"> • Torque converter clutch control valve • Pilot valve • Pilot filter 	
OK or NG	
OK	▶ GO TO 4.
NG	▶ Repair or replace damaged parts.

4	CHECK SYMPTOM
Check again.	
OK or NG	
OK	▶ INSPECTION END
NG	▶ <ol style="list-style-type: none"> Perform TCM input/output signal inspection. If NG, recheck TCM pin terminals for damage or loose connection with harness connector.

5	DETECT MALFUNCTIONING ITEM
<ol style="list-style-type: none"> Remove control valve assembly. Refer to AT-225. Check the following items: <ul style="list-style-type: none"> • Torque converter clutch control valve • Pilot valve • Pilot filter Disassemble A/T. Check torque converter and oil pump assembly. 	
OK or NG	
OK	▶ GO TO 4.
NG	▶ Repair or replace damaged parts.

TROUBLE DIAGNOSES FOR SYMPTOMS



14. Lock-up Is Not Released

14. Lock-up Is Not Released

=NAAT0086

SYMPTOM:

Lock-up is not released when accelerator pedal is released.

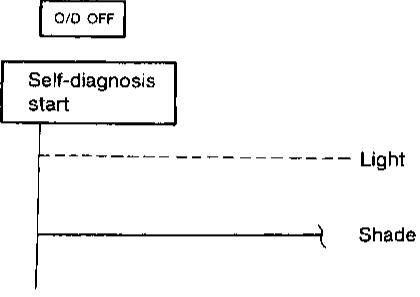
1	CHECK THROTTLE POSITION SWITCH CIRCUIT
<p> With CONSULT Does "ECU INPUT SIGNALS" in Data Monitor show damage to closed throttle position switch circuit?</p>	
<p> Without CONSULT Does self-diagnosis show damage to closed throttle position switch circuit?</p> <div style="text-align: center;">  <p>The diagram shows a vertical line starting from a box labeled "Self-diagnosis start". A dashed horizontal line extends to the right from the vertical line, labeled "Light". A solid horizontal line extends to the right from the vertical line, labeled "Shade". Above the "Self-diagnosis start" box is a box labeled "O/D OFF".</p> </div> <p style="text-align: right;">SAT344H</p> <p style="text-align: center;">Yes or No</p>	
Yes	▶ Check closed throttle position switch circuit. Refer to "DTC P1705", AT-165.
No	▶ GO TO 2.

2	CHECK SYMPTOM
Check again.	
OK or NG	
OK	▶ INSPECTION END
NG	▶ <ul style="list-style-type: none"> 1. Perform TCM input/output signal inspection. 2. If NG, recheck TCM pin terminals for damage or loose connection with harness connector.

TROUBLE DIAGNOSES FOR SYMPTOMS

15. Engine Speed Does Not Return To Idle (Light Braking D₄ → D₃)

15. Engine Speed Does Not Return To Idle (Light Braking D₄ → D₃)

=NAAT0087

SYMPTOM:

- Engine speed does not smoothly return to idle when A/T shifts from D₄ to D₃.
- Vehicle does not decelerate by engine brake when turning overdrive control switch OFF.
- Vehicle does not decelerate by engine brake when shifting A/T from "D" to "2" position.

1	CHECK SELF-DIAGNOSTIC RESULTS
Does self-diagnosis show damage to overrun clutch solenoid valve circuit after cruise test?	
SAT348H	
Yes or No	
Yes	▶ Check overrun clutch solenoid valve circuit. Refer to "DTC P1760", AT-171.
No	▶ GO TO 2.

2	CHECK THROTTLE POSITION SENSOR
Check throttle position sensor. Refer to EC section ("DTC P0120 THROTTLE POSITION SENSOR").	
SAT329I	
OK or NG	
OK	▶ GO TO 3.
NG	▶ Repair or replace throttle position sensor.

3	CHECK A/T FLUID CONDITION
1. Remove oil pan. 2. Check A/T fluid condition.	
OK or NG	
OK	▶ GO TO 4.
NG	▶ GO TO 6.

4	DETECT MALFUNCTIONING ITEM
1. Remove control valve assembly. Refer to AT-225. 2. Check the following items: <ul style="list-style-type: none"> • Overrun clutch control valve • Overrun clutch reducing valve • Overrun clutch solenoid valve 	
OK or NG	
OK	▶ GO TO 5.
NG	▶ Repair or replace damaged parts.

5	CHECK SYMPTOM
Check again.	
OK or NG	
OK	▶ INSPECTION END
NG	▶ 1. Perform TCM input/output signal inspection. 2. If NG, recheck TCM pin terminals for damage or loose connection with harness connector.

TROUBLE DIAGNOSES FOR SYMPTOMS

15. Engine Speed Does Not Return To Idle (Light Braking D₄ → D₃) (Cont'd)

6	DETECT MALFUNCTIONING ITEM	
1. Remove control valve assembly. Refer to AT-225. 2. Check the following items: <ul style="list-style-type: none"> ● Overrun clutch control valve ● Overrun clutch reducing valve ● Overrun clutch solenoid valve 3. Disassemble A/T. 4. Check the following items: <ul style="list-style-type: none"> ● Overrun clutch assembly ● Oil pump assembly 		
OK or NG		
OK	▶	GO TO 5.
NG	▶	Repair or replace damaged parts.

16. Vehicle Does Not Start From D₁

NAAT0088

SYMPTOM:

Vehicle does not start from D₁ on Cruise test — Part 2.

1	CHECK SELF-DIAGNOSTIC RESULTS	
Does self-diagnosis show damage to vehicle speed sensor-A/T (revolution sensor), shift solenoid valve A, B or vehicle speed sensor-MTR after cruise test?		
SAT6331		
Yes or No		
Yes	▶	Check damaged circuit. Refer to "DTC P0720, P0750, P0755 or VHCL SPEED SEN-MTR", AT-99, 154, 159 or 181.
No	▶	GO TO 2.

2	CHECK SYMPTOM	
Check again.		
OK or NG		
OK	▶	Go to "8. Vehicle Cannot Be Started From D ₁ ", AT-196.
NG	▶	1. Perform TCM input/output signal inspection. 2. If NG, recheck TCM pin terminals for damage or loose connection with harness connector.

TROUBLE DIAGNOSES FOR SYMPTOMS

17. A/T Does Not Shift: D₄ → D₃, When Overdrive Control Switch "ON" → "OFF"

17. A/T Does Not Shift: D₄ → D₃, When Overdrive Control Switch "ON" → "OFF"

=NAAT0089

SYMPTOM:

A/T does not shift from D₄ to D₃ when changing overdrive control switch to "OFF" position.

GI
MA
EM
LC
EC
FE
CL
MT
AT
TF
PD
AX
SU
BR
ST
RS
BT
HA
SC
EL
IDX

1	CHECK OVERDRIVE CONTROL SWITCH CIRCUIT
<p><input type="checkbox"/> With CONSULT Does "ECU INPUT SIGNALS" in Data Monitor show damage to overdrive control switch circuit?</p>	
<p><input checked="" type="checkbox"/> Without CONSULT Does self-diagnosis show damage to overdrive control switch circuit?</p> <div style="text-align: center;"> <pre> graph TD A[O/D OFF] --- B[Self-diagnosis start] B -.-> C[Light] B --> D[Shade] </pre> </div> <p style="text-align: right;">SAT344H</p>	
Yes or No	
Yes	▶ Check overdrive control switch circuit. Refer to AT-213.
No	▶ Go to "10. A/T Does Not Shift: D ₂ → D ₃ ", AT-200.

TROUBLE DIAGNOSES FOR SYMPTOMS

18. A/T Does Not Shift: $D_3 \rightarrow 2_2$, When Selector Lever "D" \rightarrow "2" Position

18. A/T Does Not Shift: $D_3 \rightarrow 2_2$, When Selector Lever "D" \rightarrow "2" Position

=NAAT0090

SYMPTOM:

A/T does not shift from D_3 to 2_2 when changing selector lever from "D" to "2" position.

1	CHECK INHIBITOR SWITCH CIRCUIT
<p><input type="checkbox"/> With CONSULT Does "ECU INPUT SIGNALS" in Data Monitor show damage to inhibitor switch circuit?</p>	
<p><input checked="" type="checkbox"/> Without CONSULT Does self-diagnosis show damage to inhibitor switch circuit?</p>	
SAT344H	
Yes or No	
Yes	▶ Check inhibitor switch circuit. Refer to "DTC P0705", AT-89.
No	▶ Go to "9. A/T Does Not Shift: $D_1 \rightarrow D_2$ Or Does Not Kickdown: $D_4 \rightarrow D_2$ ", AT-198.

TROUBLE DIAGNOSES FOR SYMPTOMS

19. A/T Does Not Shift: 2₂ → 1₁, When Selector Lever "2" → "1" Position

19. A/T Does Not Shift: 2₂ → 1₁, When Selector Lever "2" → "1" Position

MAAAT0091

SYMPTOM:

A/T does not shift from 2₂ to 1₁ when changing selector lever from "2" to "1" position.

1 CHECK INHIBITOR SWITCH CIRCUIT	
<p>With CONSULT Does "ECU INPUT SIGNALS" in Data Monitor show damage to inhibitor switch circuit?</p>	
<p>Without CONSULT Does self-diagnosis show damage to inhibitor switch circuit?</p>	
Yes or No	
Yes	▶ Check inhibitor switch circuit. Refer to "DTC P0705", AT-89.
No	▶ GO TO 2.

2 CHECK SYMPTOM	
Check again.	
OK or NG	
OK	▶ INSPECTION END
NG	▶ 1. Perform TCM input/output signal inspection. 2. If NG, recheck TCM pin terminals for damage or loose connection with harness connector.

20. Vehicle Does Not Decelerate By Engine Brake

MAAAT0092

SYMPTOM:

Vehicle does not decelerate by engine brake when shifting from 2₂ (1₂) to 1₁.

1 CHECK SYMPTOM	
Is "6. Vehicle Does Not Creep Backward In "R" Position" OK?	
Yes or No	
Yes	▶ Go to "15. Engine Speed Does Not Return To Idle (Light Braking D ₄ → D ₃)", AT-207.
No	▶ Go to "6. Vehicle Does Not Creep Backward In "R" Position", AT-192.

TROUBLE DIAGNOSES FOR SYMPTOMS

21. TCM Self-diagnosis Does Not Activate (Inhibitor, Overdrive Control and Throttle Position Switches Circuit Checks)

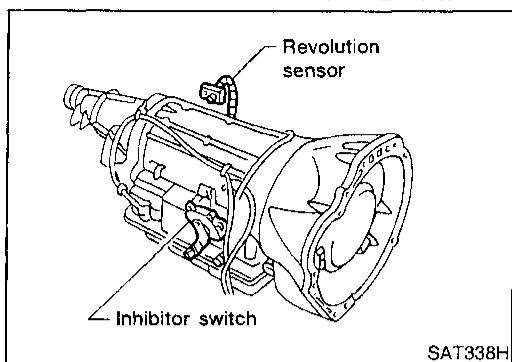

21. TCM Self-diagnosis Does Not Activate (Inhibitor, Overdrive Control and Throttle Position Switches Circuit Checks)

NAAT0204

SYMPTOM:

O/D OFF indicator lamp does not come on in TCM self-diagnostic procedure even the lamp circuit is good.

DESCRIPTION

NAAT0204S01

- Inhibitor switch
Detects the selector lever position and sends a signal to the TCM.
- Overdrive control switch
Detects the overdrive control switch position (ON or OFF) and sends a signal to the TCM.
- Throttle position switch
Consists of a wide-open throttle position switch and a closed throttle position switch.
The wide-open position switch sends a signal to the TCM when the throttle valve is open at least 1/2 of the full throttle position.
The closed throttle position switch sends a signal to the TCM when the throttle valve is fully closed.

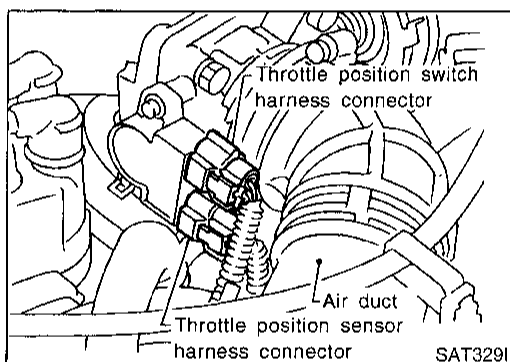
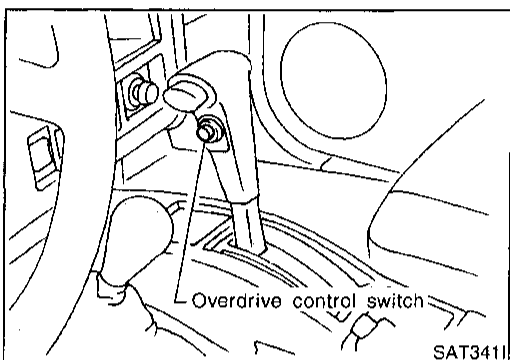

TROUBLE DIAGNOSES FOR SYMPTOMS

21. TCM Self-diagnosis Does Not Activate (Inhibitor, Overdrive Control and Throttle Position Switches Circuit Checks) (Cont'd)

DIAGNOSTIC PROCEDURE

-NAAT0204S03

NOTE:

The diagnostic procedure includes inspections for the overdrive control and throttle position switch circuits.

1	CHECK INHIBITOR SWITCH CIRCUIT (With CONSULT)																														
<p>Ⓟ With CONSULT</p> <ol style="list-style-type: none"> Turn ignition switch to "ON" position. (Do not start engine.) Select "ECU INPUT SIGNALS" in "DATA MONITOR" mode for "A/T" with CONSULT. Read out "P", "R", "N", "D", "2" and "1" position switches moving selector lever to each position. Check the signal of the selector lever position is indicated properly. 																															
<table border="1" style="margin: auto;"> <tr> <td>☆ MONITOR</td> <td>☆ NO FAIL</td> <td></td> </tr> <tr> <td>R POSITION SW</td> <td>OFF</td> <td></td> </tr> <tr> <td>D POSITION SW</td> <td>OFF</td> <td></td> </tr> <tr> <td>2 POSITION SW</td> <td>OFF</td> <td></td> </tr> <tr> <td>1 POSITION SW</td> <td>OFF</td> <td></td> </tr> <tr> <td>ASCD•CRUISE</td> <td>OFF</td> <td></td> </tr> <tr> <td>ASCD•OD CUT</td> <td>OFF</td> <td></td> </tr> <tr> <td>KICKDOWN SW</td> <td>OFF</td> <td></td> </tr> <tr> <td>POWER SHIFT SW</td> <td>OFF</td> <td></td> </tr> <tr> <td>CLOSED THL/SW</td> <td>OFF</td> <td></td> </tr> </table>		☆ MONITOR	☆ NO FAIL		R POSITION SW	OFF		D POSITION SW	OFF		2 POSITION SW	OFF		1 POSITION SW	OFF		ASCD•CRUISE	OFF		ASCD•OD CUT	OFF		KICKDOWN SW	OFF		POWER SHIFT SW	OFF		CLOSED THL/SW	OFF	
☆ MONITOR	☆ NO FAIL																														
R POSITION SW	OFF																														
D POSITION SW	OFF																														
2 POSITION SW	OFF																														
1 POSITION SW	OFF																														
ASCD•CRUISE	OFF																														
ASCD•OD CUT	OFF																														
KICKDOWN SW	OFF																														
POWER SHIFT SW	OFF																														
CLOSED THL/SW	OFF																														
<table border="1" style="margin: auto;"> <tr> <td style="text-align: center; padding: 5px;">RECORD</td> </tr> </table>		RECORD																													
RECORD																															
SAT7611																															
OK or NG																															
OK	▶ GO TO 3.																														
NG	<p>▶ Check the following items:</p> <ul style="list-style-type: none"> Inhibitor switch Refer to "Component Inspection", AT-216. Harness for short or open between ignition switch and inhibitor switch (Main harness) Harness for short or open between inhibitor switch and TCM (Main harness) 																														

2	CHECK INHIBITOR SWITCH CIRCUIT (Without CONSULT)																																									
<p>ⓧ Without CONSULT</p> <ol style="list-style-type: none"> Turn ignition switch to "ON" position. (Do not start engine.) Check voltage between TCM terminals 16, 17, 18, 19, 20 and ground while moving selector lever through each position. 																																										
<table border="1" style="margin: auto;"> <thead> <tr> <th rowspan="2">Lever position</th> <th colspan="5">Terminals</th> </tr> <tr> <th>19</th> <th>20</th> <th>18</th> <th>17</th> <th>16</th> </tr> </thead> <tbody> <tr> <td>P, N</td> <td style="text-align: center;">B</td> <td style="text-align: center;">0</td> <td style="text-align: center;">0</td> <td style="text-align: center;">0</td> <td style="text-align: center;">0</td> </tr> <tr> <td>R</td> <td style="text-align: center;">0</td> <td style="text-align: center;">B</td> <td style="text-align: center;">0</td> <td style="text-align: center;">0</td> <td style="text-align: center;">0</td> </tr> <tr> <td>D</td> <td style="text-align: center;">0</td> <td style="text-align: center;">0</td> <td style="text-align: center;">B</td> <td style="text-align: center;">0</td> <td style="text-align: center;">0</td> </tr> <tr> <td>2</td> <td style="text-align: center;">0</td> <td style="text-align: center;">0</td> <td style="text-align: center;">0</td> <td style="text-align: center;">B</td> <td style="text-align: center;">0</td> </tr> <tr> <td>1</td> <td style="text-align: center;">0</td> <td style="text-align: center;">0</td> <td style="text-align: center;">0</td> <td style="text-align: center;">0</td> <td style="text-align: center;">B</td> </tr> </tbody> </table>		Lever position	Terminals					19	20	18	17	16	P, N	B	0	0	0	0	R	0	B	0	0	0	D	0	0	B	0	0	2	0	0	0	B	0	1	0	0	0	0	B
Lever position	Terminals																																									
	19	20	18	17	16																																					
P, N	B	0	0	0	0																																					
R	0	B	0	0	0																																					
D	0	0	B	0	0																																					
2	0	0	0	B	0																																					
1	0	0	0	0	B																																					
MTBL0047																																										
SAT069J																																										
<p>Does battery voltage exist (B) or non-existent (0)?</p>																																										
Yes	▶ GO TO 3.																																									
No	<p>▶ Check the following items:</p> <ul style="list-style-type: none"> Inhibitor switch Refer to "Component Inspection", AT-216. Harness for short or open between ignition switch and inhibitor switch (Main harness) Harness for short or open between inhibitor switch and TCM (Main harness) 																																									

TROUBLE DIAGNOSES FOR SYMPTOMS

21. TCM Self-diagnosis Does Not Activate (Inhibitor, Overdrive Control and Throttle Position Switches Circuit Checks) (Cont'd)

3
CHECK OVERDRIVE CONTROL SWITCH CIRCUIT

Ⓜ With CONSULT

- Turn ignition switch to "ON" position.
(Do not start engine.)
- Select "ECU INPUT SIGNALS" in "DATA MONITOR" mode for "A/T" with CONSULT.
- Read out "OVERDRIVE SWITCH". Check the signal of the overdrive control switch is indicated properly.
(Overdrive control switch "ON" displayed on CONSULT means overdrive "OFF".)

☆ MONITOR	☆ NO FAIL	▼
VHCL/S SE•A/T	0km/h	
VHCL/S SE•MTR	5km/h	
THRTL POS SEN	0.4V	
FLUID TEMP SE	1.2V	
BATTERY VOLT	13.4V	
ENGINE SPEED	1024rpm	
OVERDRIVE SW	O N	
P/N POSI SW	O N	
R POSITION SW	OFF	

RECORD

SAT076H

ⓧ Without CONSULT

- Turn ignition switch to "ON" position.
(Do not start engine.)
- Check voltage between TCM terminal 39 and ground when overdrive control switch is "ON" and "OFF".

Voltage:

Switch position "ON":
Battery voltage

Switch position "OFF":
1V or less

SAT081J

OK or NG

OK	▶	GO TO 3.
NG	▶	<p>Check the following items:</p> <ul style="list-style-type: none"> ● Overdrive control switch Refer to "Component Inspection", AT-216. ● Harness for short or open between TCM and overdrive control switch (Main harness) ● Harness for short or open of ground circuit for overdrive control switch (Main harness)

4
CHECK THROTTLE POSITION SWITCH CIRCUIT (With CONSULT)

Ⓜ With CONSULT

- Turn ignition switch to "ON" position.
(Do not start engine.)
- Select "ECU INPUT SIGNALS" in "DATA MONITOR" mode for "A/T" with CONSULT.
- Read out "CLOSED THL/SW" and "W/O THRL/P-SW" depressing and releasing accelerator pedal.
Check the signal of throttle position switch is indicated properly.

Accelerator pedal condition	Data monitor	
	CLOSED THL/SW	W/O THRL/P-SW
Released	ON	OFF
Fully depressed	OFF	ON

MTBL0011

☆ MONITOR	☆ NO FAIL	▼
POWERSHIFT SW	OFF	
CLOSED THL/SW	ON	
W/O THRL/P-SW	OFF	
HOLD SW	OFF	

RECORD

SAT052I

OK or NG

OK	▶	GO TO 6.
NG	▶	<p>Check the following items:</p> <ul style="list-style-type: none"> ● Throttle position switch Refer to "Component Inspection", AT-217. ● Harness for short or open between ignition switch and throttle position switch (Main harness) ● Harness for short or open between throttle position switch and TCM (Main harness)

918

AT-214

TROUBLE DIAGNOSES FOR SYMPTOMS

21. TCM Self-diagnosis Does Not Activate (Inhibitor, Overdrive Control and Throttle Position Switches Circuit Checks) (Cont'd)

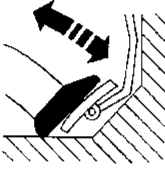
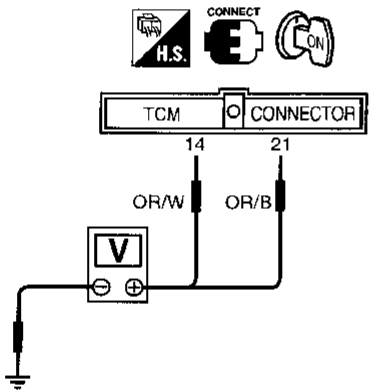
5	CHECK THROTTLE POSITION SWITCH CIRCUIT (Without CONSULT)											
<p>⊗ Without CONSULT</p> <ol style="list-style-type: none"> Turn ignition switch to "ON" position. (Do not start engine.) Check voltage between TCM terminals 14, 21 and ground while depressing, and releasing accelerator pedal slowly. (after warming up engine) 												
<table border="1" style="margin: auto; border-collapse: collapse;"> <thead> <tr> <th rowspan="2">Accelerator pedal condition</th> <th colspan="2">Voltage</th> </tr> <tr> <th>Terminal No. 14</th> <th>Terminal No. 21</th> </tr> </thead> <tbody> <tr> <td>Released</td> <td>Battery voltage</td> <td>1V or less</td> </tr> <tr> <td>Fully depressed</td> <td>1V or less</td> <td>Battery voltage</td> </tr> </tbody> </table>		Accelerator pedal condition	Voltage		Terminal No. 14	Terminal No. 21	Released	Battery voltage	1V or less	Fully depressed	1V or less	Battery voltage
Accelerator pedal condition	Voltage											
	Terminal No. 14	Terminal No. 21										
Released	Battery voltage	1V or less										
Fully depressed	1V or less	Battery voltage										
MTBL0073												
												
												
SAT078J												
OK or NG												
OK	▶ GO TO 6.											
NG	▶ Check the following items: <ul style="list-style-type: none"> ● Throttle position switch Refer to "Component Inspection", AT-217. ● Harness for short or open between ignition switch and throttle position switch (Main harness) ● Harness for short or open between throttle position switch and TCM (Main harness) 											

6	CHECK DTC
Perform Diagnostic procedure, AT-213.	
OK or NG	
OK	▶ INSPECTION END
NG	▶ <ol style="list-style-type: none"> Perform TCM input/output signal inspection. If NG, recheck TCM pin terminals for damage or loose connection with harness connector.

GI
 MA
 EM
 LC
 EC
 FE
 CL
 MT
 AT
 TF
 PD
 AX
 SU
 BR
 ST
 RS
 BT
 HA
 SC
 EL
 IDX

TROUBLE DIAGNOSES FOR SYMPTOMS

21. TCM Self-diagnosis Does Not Activate (Inhibitor, Overdrive Control and Throttle Position Switches Circuit Checks) (Cont'd)

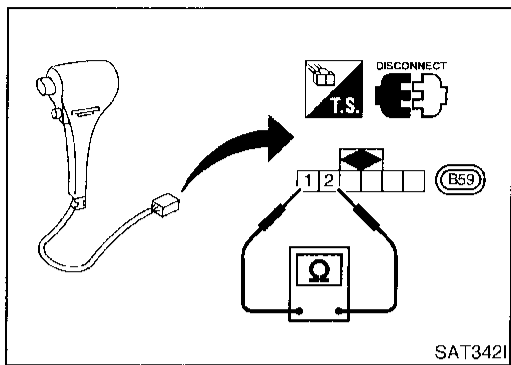

COMPONENT INSPECTION

Overdrive Control Switch

NAAT0204S04

NAAT0204S0401

- Check continuity between two terminals.

Continuity:

Switch position "ON":

No

Switch position "OFF":

Yes

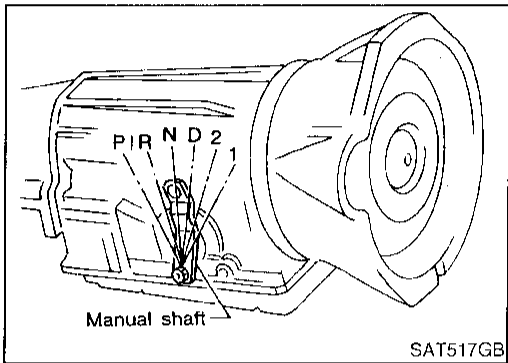

Inhibitor Switch

NAAT0204S0402

1. Check continuity between terminals 1 and 2 and between terminals 3 and 4, 5, 6, 7, 8, 9 while moving manual shaft through each position.

Lever position	Terminal No.	
P	1 - 2	3 - 4
R	3 - 5	
N	1 - 2	3 - 6
D	3 - 7	
2	3 - 8	
1	3 - 9	

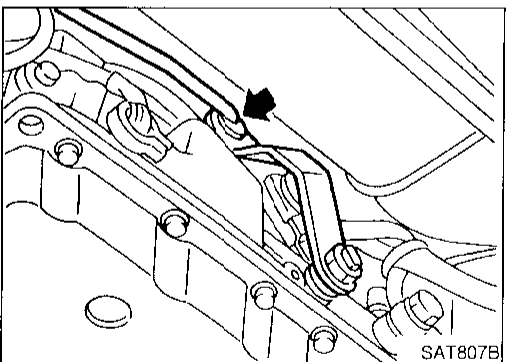
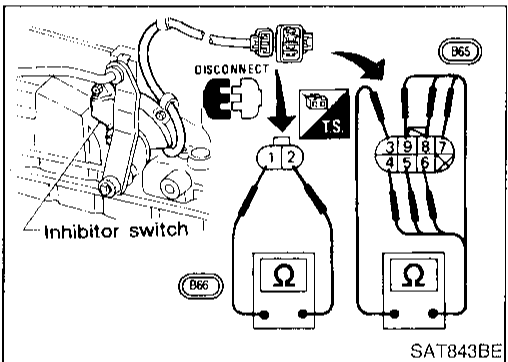

2. If NG, check again with manual control linkage disconnected from manual shaft of A/T assembly. Refer to step 1.
3. If OK on step 2, adjust manual control linkage. Refer to AT-227.

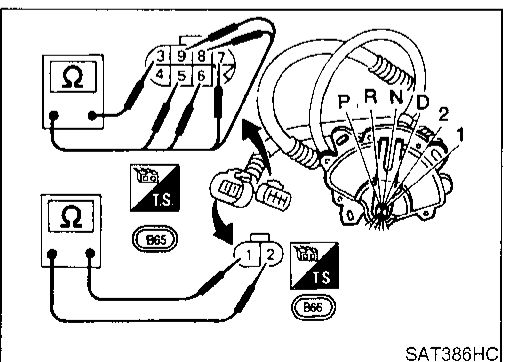

4. If NG on step 2, remove inhibitor switch from A/T and check continuity of inhibitor switch terminals. Refer to step 1.
5. If OK on step 4, adjust inhibitor switch. Refer to AT-227.
6. If NG on step 4, replace inhibitor switch.

TROUBLE DIAGNOSES FOR SYMPTOMS

21. TCM Self-diagnosis Does Not Activate (Inhibitor, Overdrive Control and Throttle Position Switches Circuit Checks) (Cont'd)

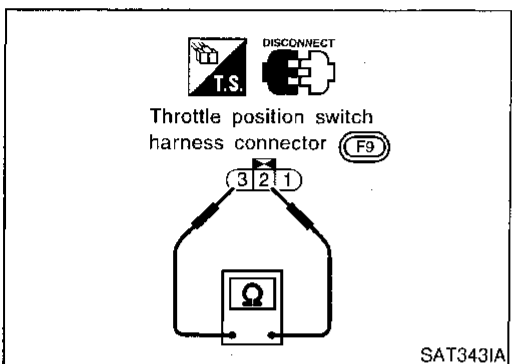
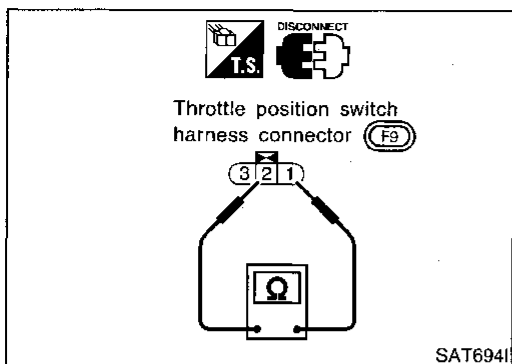

Throttle Position Switch

NAAT0204S0403

Closed Throttle Position Switch (Idle Position)

- Check continuity between terminals 1 and 2.

Accelerator pedal condition	Continuity
Released	Yes
Depressed	No

- To adjust closed throttle position switch, refer to EC section ("Basic Inspection", "TROUBLE DIAGNOSIS — Basic Inspection").

Wide Open Throttle Position Switch

- Check continuity between terminals 2 and 3.

Accelerator pedal condition	Continuity
Released	No
Depressed	Yes

GI

MA

EM

LC

EC

FE

CL

MT

AT

TF

PD

AX

SU

BR

ST

RS

BT

HA

SC

EL

IDX

A/T SHIFT LOCK SYSTEM

Description

Description

NAAT0093

- The mechanical key interlock mechanism also operates as a shift lock:
With the key switch turned to "ON", the selector lever cannot be shifted from "P" (parking) to any other position unless the brake pedal is depressed.
With the key removed, the selector lever cannot be shifted from "P" to any other position.
The key cannot be removed unless the selector lever is placed in "P".
- The shift lock and key interlock mechanisms are controlled by the ON-OFF operation of the shift lock solenoid and by the operation of the rotator and slider located inside the key cylinder, respectively.

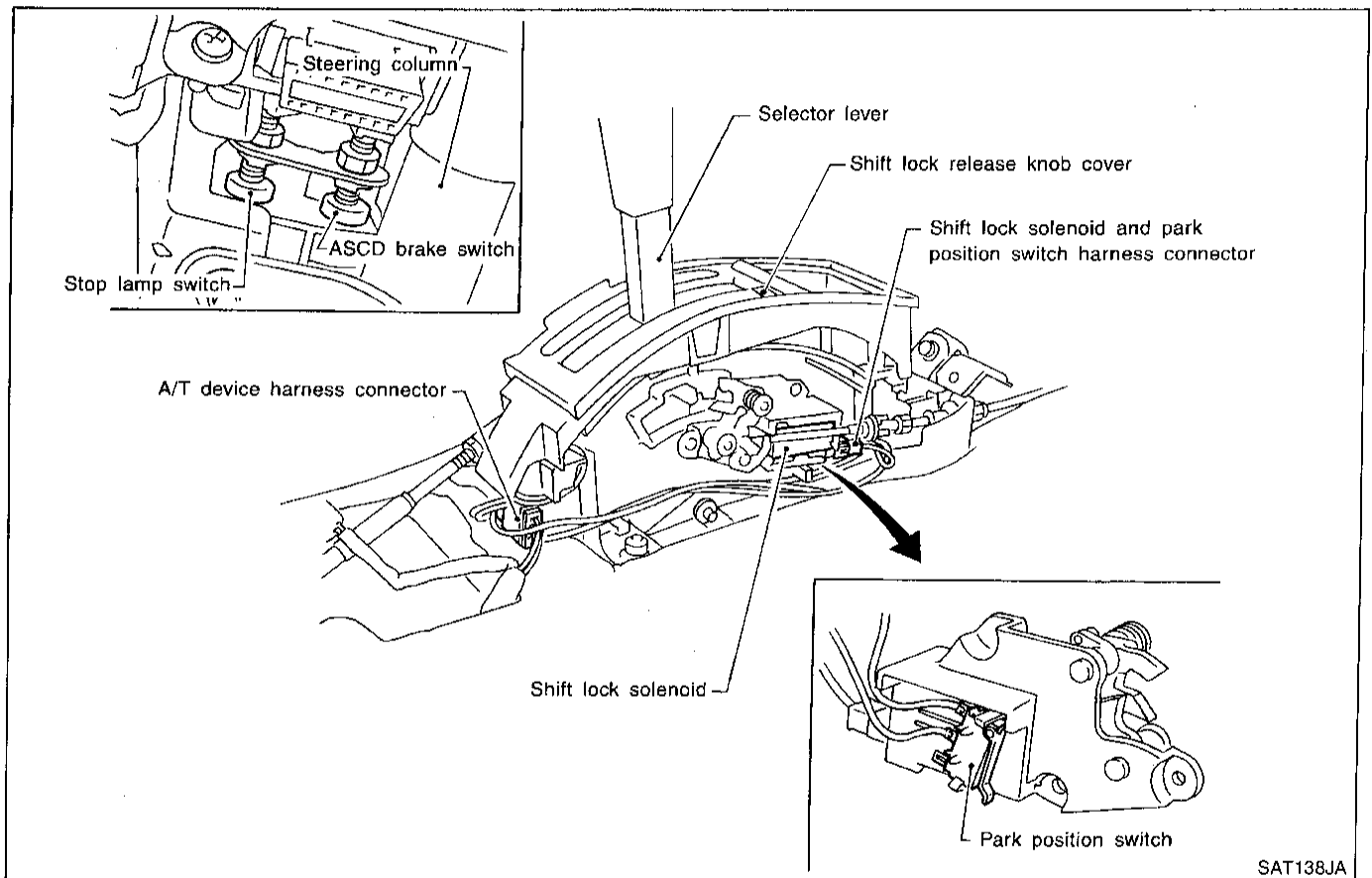

A/T SHIFT LOCK SYSTEM

Wiring Diagram — SHIFT —

Wiring Diagram — SHIFT —

NAAT70094

AT-SHIFT-01

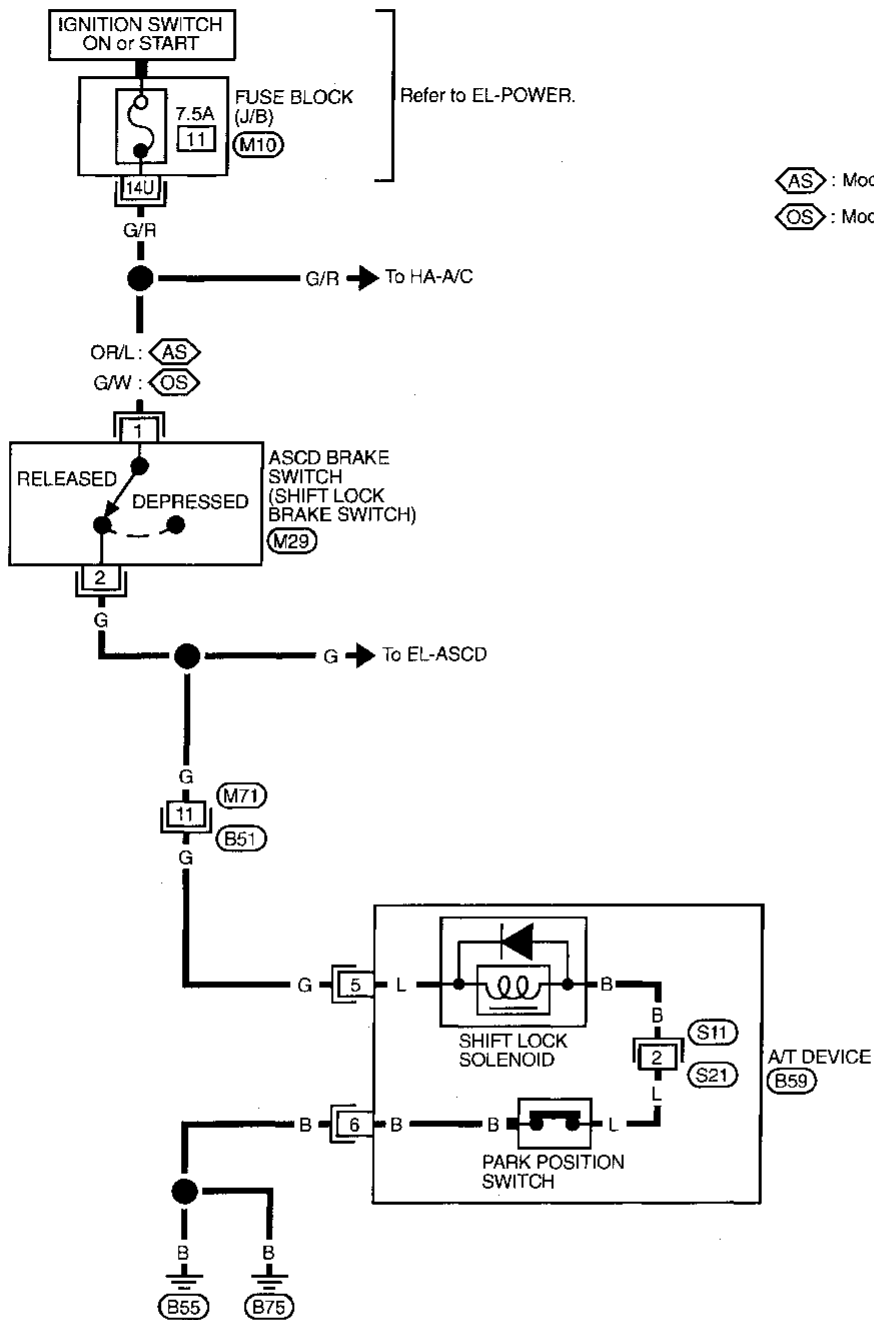

AS : Models with ASCD
OS : Models without ASCD

GI
MA
EM
LC
EC
FE
CL
MT
AT
TF
PD
AX
SU
BR
ST
RS
BT
HA
SC
EL
IDX

Refer to last page (Foldout page).

(M10)

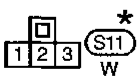
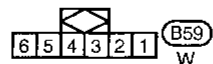
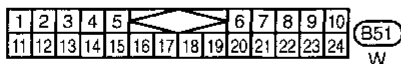
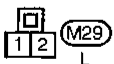

* : This connector is not shown in "HARNESS LAYOUT" in EL section.

MAT574A

AT SHIFT LOCK SYSTEM

Diagnostic Procedure

SYMPTOM 1:

- Selector lever cannot be moved from "P" position with key in "ON" position and brake pedal applied.
- Selector lever can be moved from "P" position with key in "ON" position and brake pedal released.
- Selector lever can be moved from "P" position when key is removed from key cylinder.

SYMPTOM 2:

Ignition key cannot be removed when selector lever is set to "P" position. It can be removed when selector lever is set to any position except "P".

1	CHECK KEY INTERLOCK CABLE
Check key interlock cable for damage.	
OK or NG	
OK	▶ GO TO 2.
NG	▶ Repair key interlock cable. Refer to "Key Interlock Cable", AT-223.

2	CHECK SELECTOR LEVER POSITION
Check selector lever position for damage.	
OK or NG	
OK	▶ GO TO 3.
NG	▶ Check selector lever. Refer to "ON-VEHICLE SERVICE — Inhibitor Switch and Manual Control Linkage Adjustment", AT-227 and AT-227.

3	CHECK POWER SOURCE
<p>1. Turn ignition switch to "ON" position. (Do not start engine.)</p> <p>2. Check voltage between ASCD brake switch (shift lock brake switch) harness terminal 1 and ground.</p>	
SAT917HI	
Does battery voltage exist?	
Yes	▶ GO TO 4.
No	▶ Check the following items: <ul style="list-style-type: none"> • Harness for short or open between battery and ASCD brake switch (shift lock brake switch) harness terminal 1 • Fuse • Ignition switch (Refer to EL section.)

GI
MA
EM
LC
EC
FE
CL
MT
AT
TF
PD
AX
SU
BR
ST
RS
BT
HA
SC
EL
IDX

4	CHECK INPUT SIGNAL (BRAKE SWITCH)
<p>Turn ignition switch to "ON" position. (Do not start engine.)</p> <ul style="list-style-type: none"> Check voltage between A/T device harness terminal 5 and ground. <p>Voltage: Brake pedal depressed: 0V Brake pedal released: Battery voltage</p>	
<p style="text-align: right;">SAT346IA</p>	
OK or NG	
OK	▶ GO TO 5.
NG	▶ Check the following items: <ul style="list-style-type: none"> Harness for short or open between A/T device harness connector 5 and ASCD brake switch (shift lock brake switch) harness connector 2 ASCD brake switch (shift lock brake switch) (Refer to "Component Check", AT-222.)

5	CHECK GROUND CIRCUIT
<ol style="list-style-type: none"> Turn ignition switch to "OFF" position. Disconnect A/T device harness connector. Check continuity between A/T device harness terminal 6 and ground. 	
<p style="text-align: right;">SAT347I</p>	
OK or NG	
OK	▶ GO TO 6.
NG	▶ Repair harness or connector.

6	CHECK PARK POSITION SWITCH
(Refer to "Component Check", AT-222.)	
OK or NG	
OK	▶ GO TO 7.
NG	▶ Replace park position switch.

7	CHECK SHIFT LOCK SOLENOID
(Refer to "Component Check", AT-222.)	
OK or NG	
OK	▶ GO TO 8.
NG	▶ Replace shift lock solenoid.

8	CHECK SHIFT LOCK OPERATION
<ol style="list-style-type: none"> Reconnect shift lock harness connector. Turn ignition switch from "OFF" to "ON" position. (Do not start engine.) Recheck shift lock operation. 	
OK or NG	
OK	▶ INSPECTION END
NG	▶ <ol style="list-style-type: none"> Perform A/T device input/output signal inspection test. If NG, recheck harness connector connection.

A/T SHIFT LOCK SYSTEM

Component Check

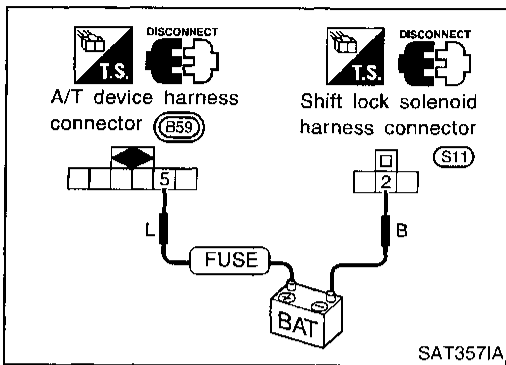

Component Check SHIFT LOCK SOLENOID

NAAT0096

NAAT0096S01

- Check operation by applying battery voltage between shift lock solenoid harness connector terminal 2 and A/T device harness connector terminal 5.

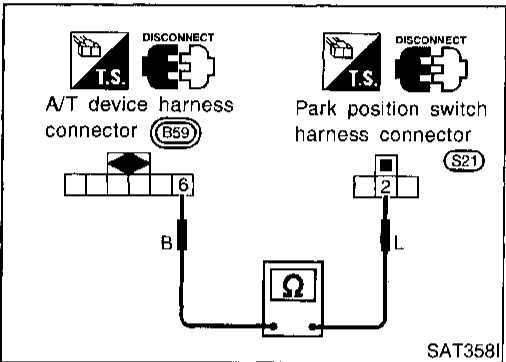

PARK POSITION SWITCH

NAAT0096S02

- Check continuity between park position switch harness connector terminal 2 and A/T device harness connector terminal 6.

Condition	Continuity
When selector lever is set in "P" position and selector lever button is released	No
Except above	Yes

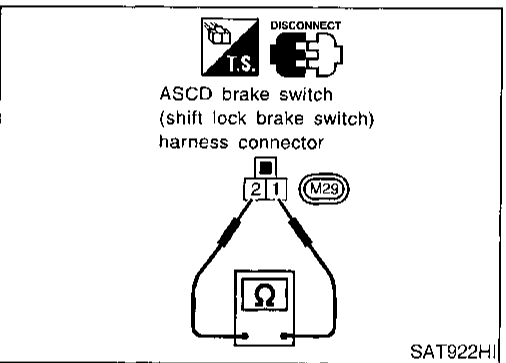

ASCD BRAKE SWITCH (SHIFT LOCK BRAKE SWITCH)

NAAT0096S03

- Check continuity between ASCD brake switch (shift lock brake switch) harness connector terminals 1 and 2.

Condition	Continuity
When brake pedal is depressed	No
When brake pedal is released	Yes

Check ASCD brake switch (shift lock brake switch) after adjusting brake pedal — refer to BR section.

Components

NAAT0087

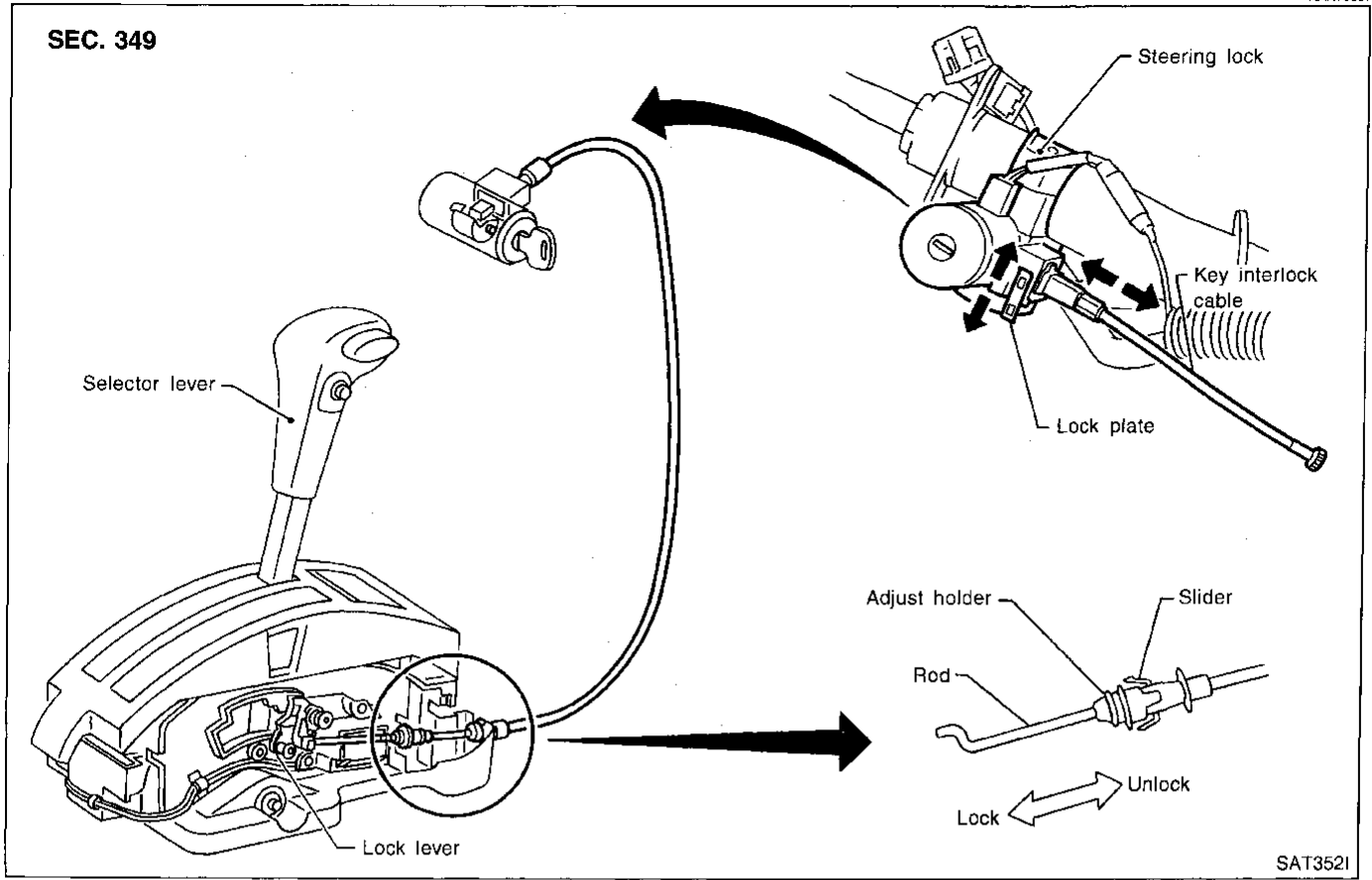

CAUTION:

- Install key interlock cable in such a way that it will not be damaged by sharp bends, twists or interference with adjacent parts.
- After installing key interlock cable to control device, make sure that casing cap and bracket are firmly secured in their positions. If casing cap can be removed with an external load of less than 39.2 N (4.0 kg, 8.8 lb), replace key interlock cable with new one.

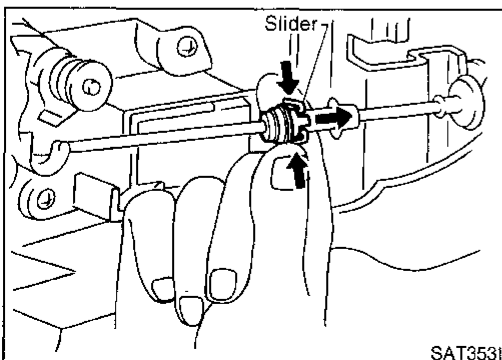

Removal

Unlock slider from adjuster holder and remove rod from cable.

NAAT0098

GI
MA
EM
LC
EC
FE
CL
MT
AT
TF
PD
AX
SU
BR
ST
RS
BT
HA
SC
EL
IDX

KEY INTERLOCK CABLE

Installation

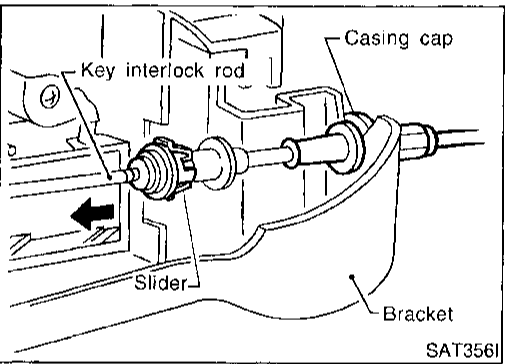
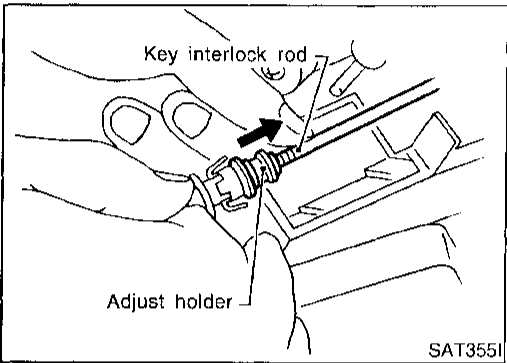
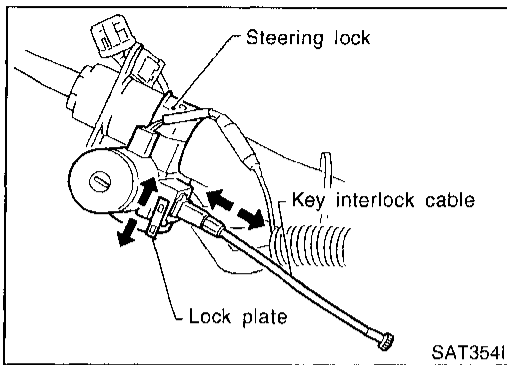

Installation

NAAT0099

1. Set key interlock cable to steering lock assembly and install lock plate.
2. Clamp cable to steering column and fix to control cable with band.
3. Set selector lever to P position.
4. Insert interlock rod into adjuster holder.
5. Install casing cap to bracket.
6. Move slider in order to fix adjuster holder to interlock rod.

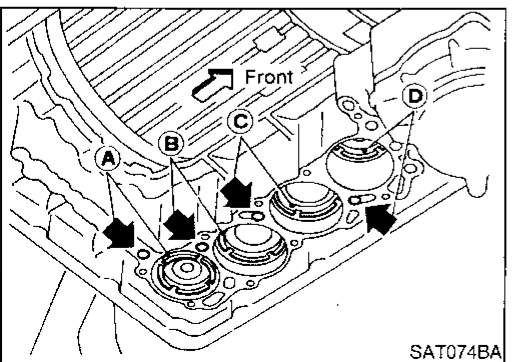
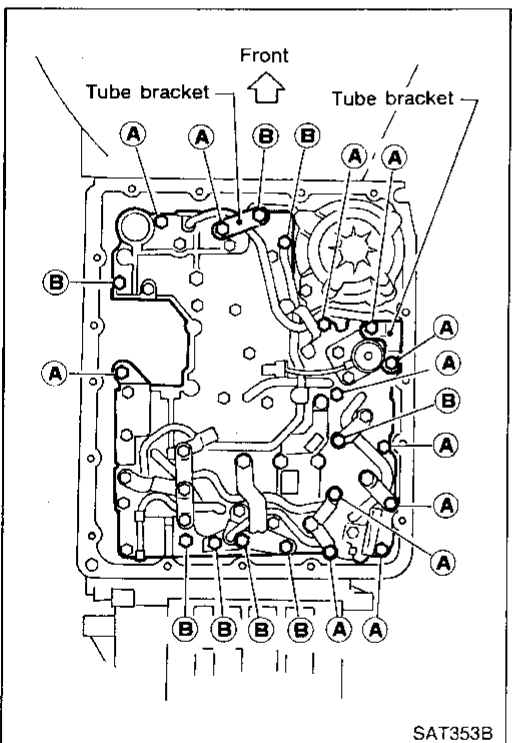
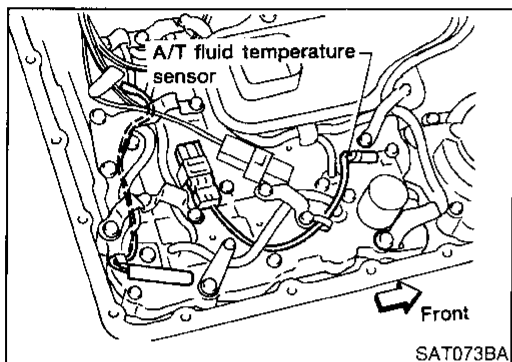
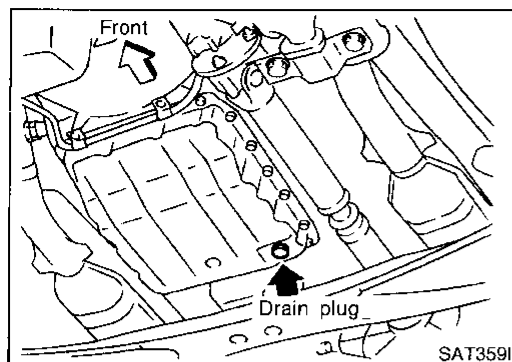

Control Valve Assembly and Accumulators

NAAT0100

NAAT0100S01

REMOVAL

1. Remove exhaust front tube.
2. Remove oil pan and gasket and drain ATF.
3. Remove A/T fluid temperature sensor if necessary.
4. Remove oil strainer.

5. Remove control valve assembly by removing fixing bolts and disconnecting harness connector.

Bolt length and location

Bolt symbol	ℓ mm (in)
A	33 (1.30)
B	45 (1.77)

6. Remove solenoids and valves from valve body if necessary.
7. Remove terminal cord assembly if necessary.

8. Remove accumulator A, B, C and D by applying compressed air if necessary.
 - Hold each piston with rag.
9. Reinstall any part removed.
 - Always use new sealing parts.

GI

MA

EM

LC

EC

FE

CL

MT

AT

TF

PD

AX

SU

BR

ST

RS

BT

HA

SC

EL

IDX

Revolution Sensor Replacement

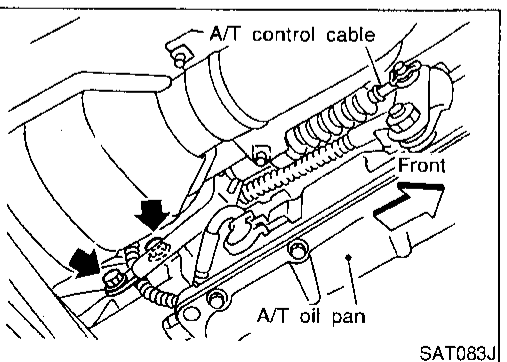
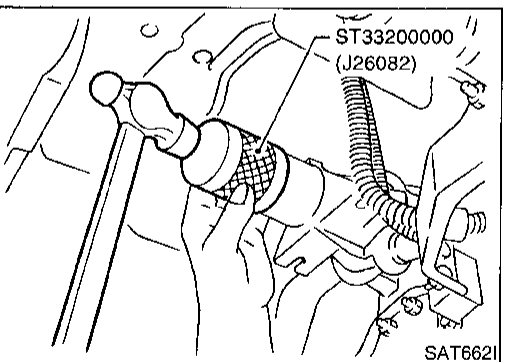
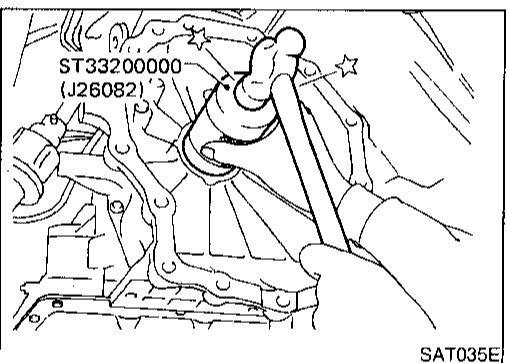
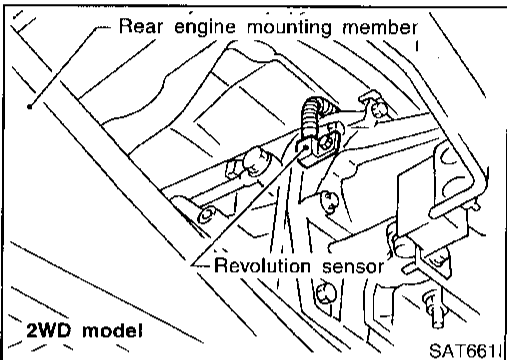
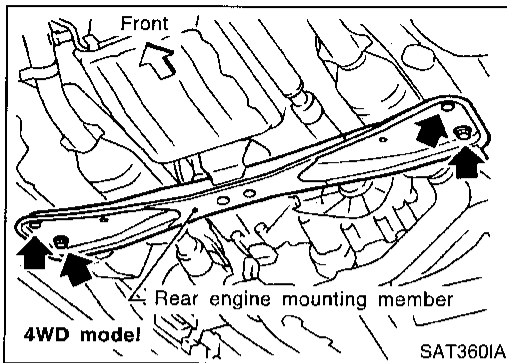

Revolution Sensor Replacement

NAAT0101

— 4WD MODEL —

NAAT0101S01

1. Remove rear engine mounting member from side member while supporting A/T with transfer case with jack. Tighten rear engine mounting member to the specified torque. Refer to EM section ("ENGINE REMOVAL").
 2. Lower A/T with transfer case as much as possible.
 3. Remove revolution sensor from A/T.
 4. Reinstall any part removed.
- **Always use new sealing parts.**

— 2WD MODEL —

NAAT0101S02

- Remove revolution sensor from A/T.
- **Always use new sealing parts.**

Rear Oil Seal Replacement

NAAT0102

— 4WD MODEL —

NAAT0102S01

1. Remove transfer case from vehicle. Refer to TF section ("Removal", "REMOVAL AND INSTALLATION").
 2. Remove rear oil seal.
 3. Install rear oil seal.
- **Apply ATF before installing.**
4. Reinstall any part removed.

— 2WD MODEL —

NAAT0102S02

1. Remove propeller shaft from vehicle. Refer to PD section ("Removal", "PROPELLER SHAFT").
 2. Remove rear oil seal.
 3. Install rear oil seal.
- **Apply ATF before installing.**
4. Reinstall any part removed.

Parking Components Inspection

NAAT0103

— 4WD MODEL —

NAAT0103S01

1. Remove propeller shaft. Refer to PD section ("Removal", "PROPELLER SHAFT").
2. Remove transfer case from vehicle. Refer to TF section ("Removal", "REMOVAL AND INSTALLATION").
3. Remove A/T control cable bracket from transmission case.

GI
MA
EM
LC
EC
FE
CL
MT
AT
TF
PD
AX
SU
BR
ST
RS
BT
HA
SC
EL
IDX

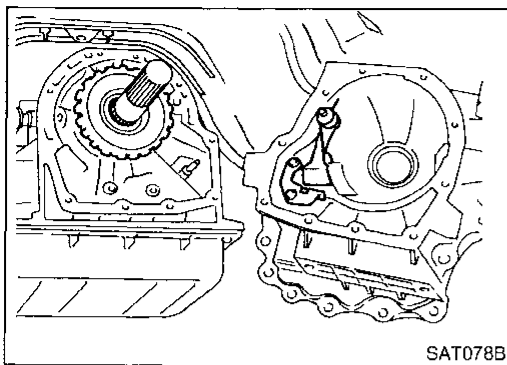

4. Support A/T assembly with a jack.
 5. Remove adapter case from transmission case.
 6. Replace parking components if necessary.
 7. Reinstall any part removed.
- **Always use new sealing parts.**

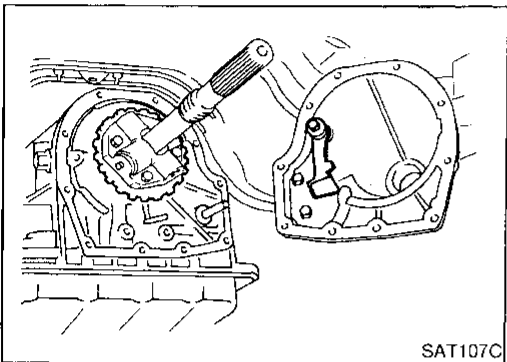

— 2WD MODEL —

1. Remove propeller shaft from vehicle. Refer to PD section ("Removal", "PROPELLER SHAFT").
2. Support A/T assembly with a jack.
3. Remove rear engine mounting member. Tighten rear engine mounting member to the specified torque. Refer to EM section ("ENGINE REMOVAL").
4. Remove rear extension from transmission case.
5. Replace parking components if necessary.
6. Reinstall any part removed.

● **Always use new sealing parts.**

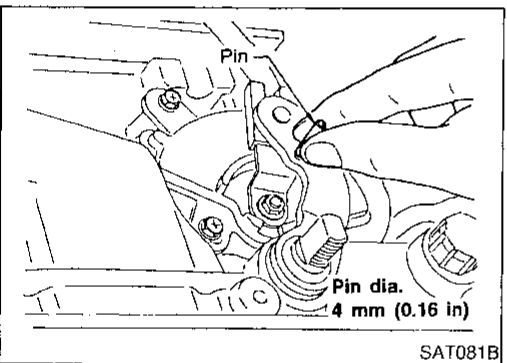

Inhibitor Switch Adjustment

1. Remove manual control linkage from manual shaft of A/T assembly.
2. Set manual shaft of A/T assembly in "N" position.
3. Loosen inhibitor switch fixing bolts.
4. Insert pin into adjustment holes in both inhibitor switch and manual shaft of A/T assembly as near vertical as possible.
5. Reinstall any part removed.
6. Check continuity of inhibitor switch. Refer to "Components Inspection", AT-90.

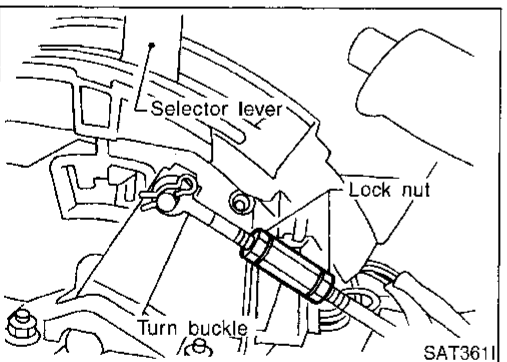

Manual Control Linkage Adjustment

Move selector lever from "P" position to "1" position. You should be able to feel the detents in each position. If the detents cannot be felt or the pointer indicating the position is improperly aligned, the linkage needs adjustment.

1. Place selector lever in "P" position.
2. Loosen lock nuts.
3. Tighten turn buckle until aligns with inner cable, pulling selector lever toward "R" position side without pushing button.
4. Back off turn buckle 1 turn and tighten lock nuts to the specified torque.

Lock nut:

⊙ : 4.4 - 5.9 N·m
(0.45 - 0.60 kg·m, 39.1 - 52.1 in·lb)

5. Move selector lever from "P" position to "1" position. Make sure that selector lever can move smoothly.

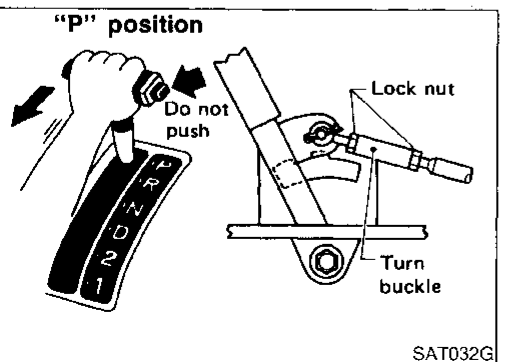

REMOVAL AND INSTALLATION

Removal

Removal

NAAT0106

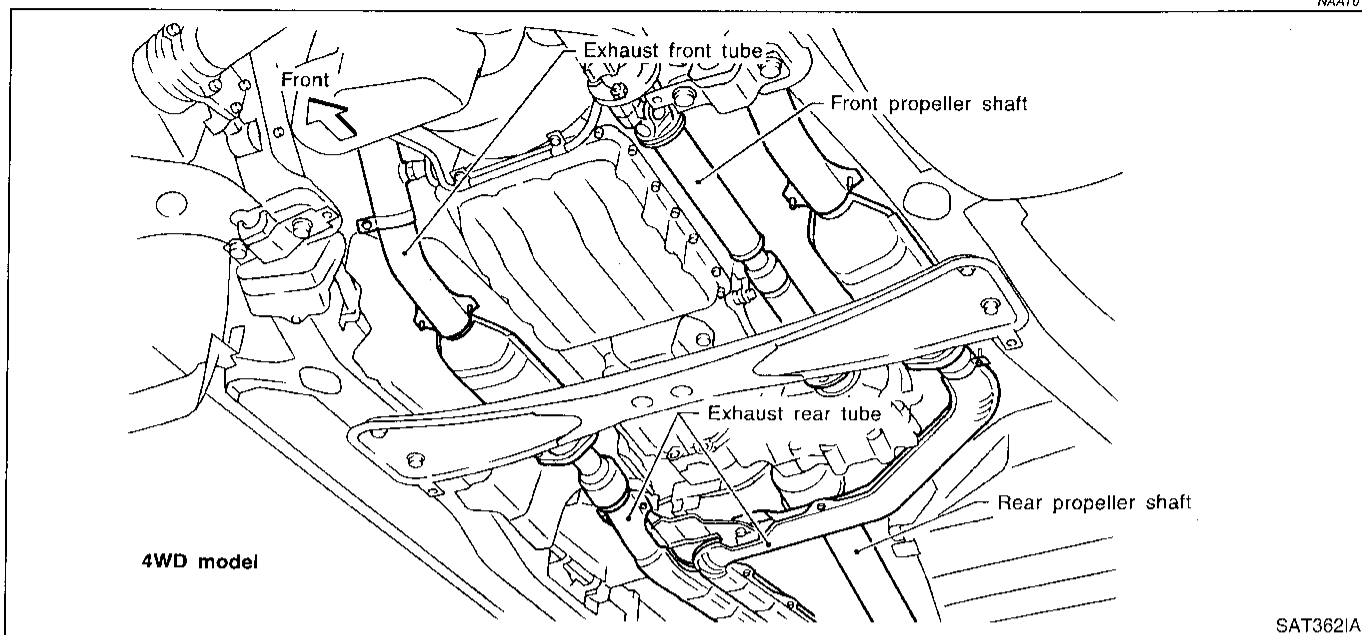

4WD model

SAT362IA

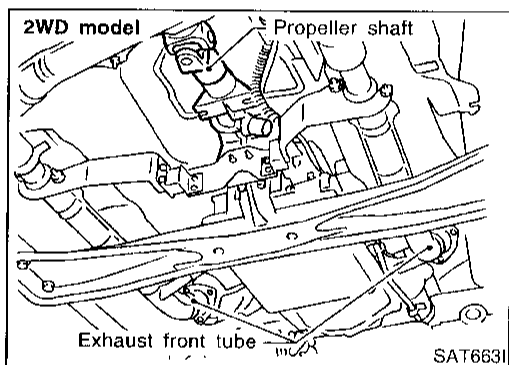

2WD model

Propeller shaft

Exhaust front tube

SAT663I

CAUTION:

When removing the A/T assembly from engine, first remove the crankshaft position sensor (OBD) from the A/T assembly upper side.

Be careful not to damage sensor edge.

— 4WD MODEL —

NAAT0106S01

1. Remove battery negative terminal.
 2. Remove exhaust front and rear tubes.
 3. Remove fluid charging pipe from A/T assembly.
 4. Remove oil cooler pipe from A/T assembly.
 5. Plug up openings such as the fluid charging pipe hole, etc.
 6. Remove propeller shaft. Refer to PD section ("Removal", "PROPELLER SHAFT").
 7. Remove transfer control linkage from transfer. Refer to TF section ("Removal" — "REMOVAL AND INSTALLATION").
- Insert plug into rear oil seal after removing rear propeller shaft.
 - Be careful not to damage spline, sleeve yoke and rear oil seal.
8. Remove A/T control cable from A/T assembly.
 9. Disconnect A/T and speedometer sensor harness connectors.
 10. Remove starter motor.

Tightening torque:

 : 41 - 52 N·m (4.2 - 5.3 kg·m, 30 - 38 ft·lb)

11. Remove gusset and rear plate cover securing engine to A/T assembly.
 12. Remove bolts securing torque converter to drive plate.
- Remove the bolts by turning crankshaft.

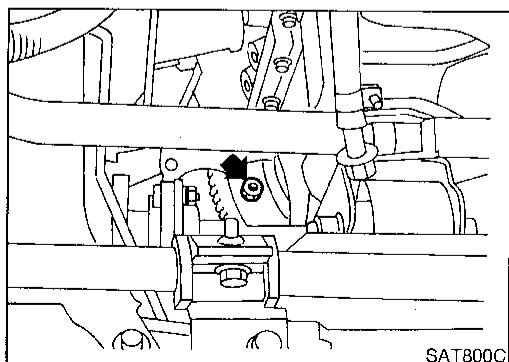

SAT800C

REMOVAL AND INSTALLATION

Removal (Cont'd)

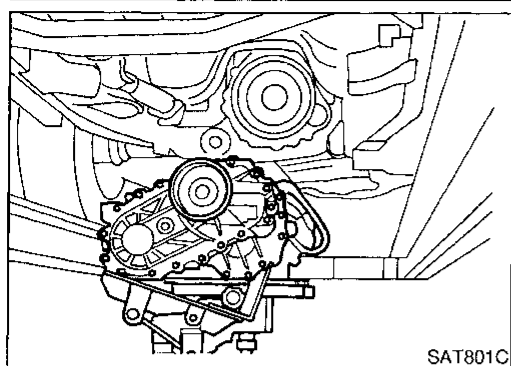

13. Support A/T and transfer assembly with a jack.
14. Remove rear engine mounting member from body and A/T assembly. Tighten rear engine mounting member to the specified torque. Refer to EM section ("ENGINE REMOVAL").
15. Remove bolts securing A/T assembly to engine.
16. Lower A/T assembly with transfer.

GI
MA
EM
LC
EC

— 2WD MODEL —

NAATO106S02

1. Remove battery negative terminal.
 2. Remove exhaust front and rear tubes.
 3. Remove fluid charging pipe from A/T assembly.
 4. Remove oil cooler pipe from A/T assembly.
 5. Plug up openings such as the fluid charging pipe hole, etc.
 6. Remove propeller shaft. Refer to PD section ("Removal", "PROPELLER SHAFT").
 7. Remove transfer control linkage from transfer. Refer to TF section ("Removal" — "REMOVAL AND INSTALLATION").
- Insert plug into rear oil seal after removing rear propeller shaft.
 - Be careful not to damage spline, sleeve yoke and rear oil seal.
8. Remove A/T control cable from A/T assembly.
 9. Disconnect A/T and speedometer sensor harness connectors.
 10. Remove starter motor.

FE
CL
MT
AT

Tightening torque:

 : 41 - 52 N·m (4.2 - 5.3 kg·m, 30 - 38 ft·lb)

11. Remove gusset and rear plate cover securing engine to A/T assembly.
 12. Remove bolts securing torque converter to drive plate.
- Remove the bolts by turning crankshaft.
13. Support A/T assembly with a jack.
 14. Remove rear engine mounting member from body and A/T assembly. Tighten rear engine mounting member to the specified torque. Refer to EM section ("ENGINE REMOVAL").
 15. Remove bolts securing A/T assembly to engine.
 16. Pull A/T assembly backwards.
- Secure torque converter to prevent it from dropping.
 - Secure A/T assembly to a jack.
17. Lower A/T assembly.

TF
PD
AX
SU
BR
ST
RS
BT

Installation

NAATO107

- Drive plate runout

Maximum allowable runout:

Refer to EM section ("Inspection", "CYLINDER BLOCK").

If this runout is out of specification, replace drive plate with ring gear.

HA
SC
EL
IDX

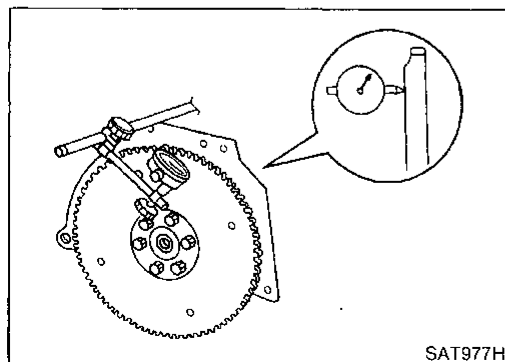

REMOVAL AND INSTALLATION

Installation (Cont'd)

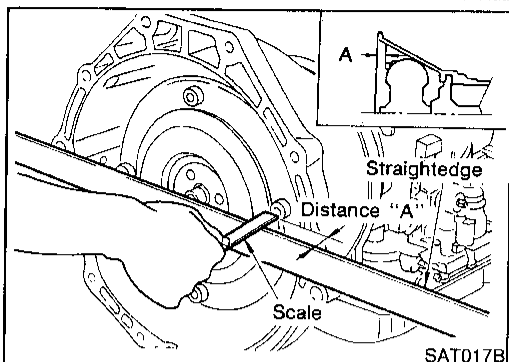

- When connecting torque converter to transmission, measure distance "A" to be certain that they are correctly assembled.

Distance "A":

26.0 mm (1.024 in) or more

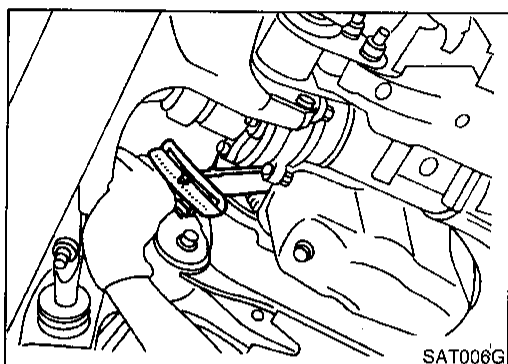

- Install converter to drive plate.
- After converter is installed to drive plate, rotate crankshaft several turns and check to be sure that transmission rotates freely without binding.

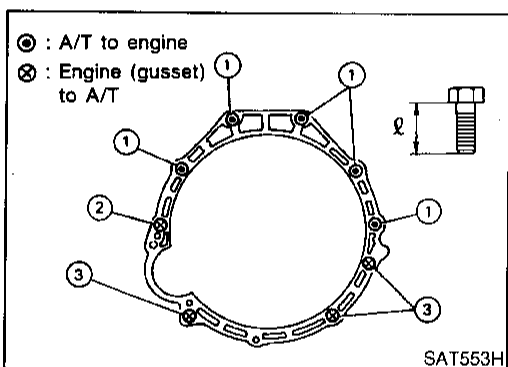

- Tighten bolts securing transmission.

Bolt No.	Tightening torque N-m (kg-m, ft-lb)	Bolt length "l" mm (in)
1	39 - 49 (4.0 - 5.0, 29 - 36)	47.5 (1.870)
2	39 - 49 (4.0 - 5.0, 29 - 36)	58.0 (2.283)
3	29 - 39 (3.0 - 4.0, 22 - 29)	25.0 (0.984)
Gusset to engine	29 - 39 (3.0 - 4.0, 22 - 29)	20.0 (0.787)

- Reinstall any part removed.
- Check fluid level in transmission.
- Move selector lever through all positions to be sure that transmission operates correctly. With parking brake applied, rotate engine at idling. Move selector lever through "N" to "D", to "2", to "1" and to "R" positions. A slight shock should be felt by hand gripping selector each time transmission is shifted.
- Perform road test. Refer to "ROAD TEST", AT-58.

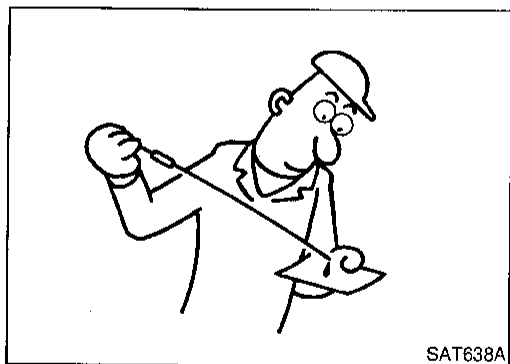

Oil Channel

NAAT0109

GI

MA

EM

LC

EC

FE

CL

MT

AT

TF

PD

AX

SU

BR

ST

RS

BT

HA

SC

EL

IDX

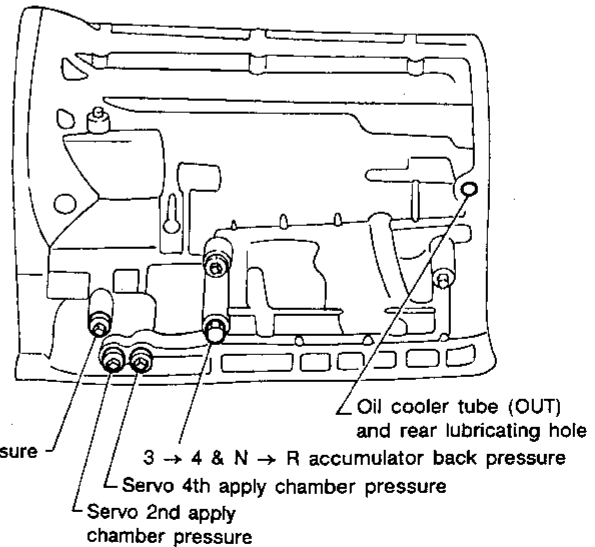
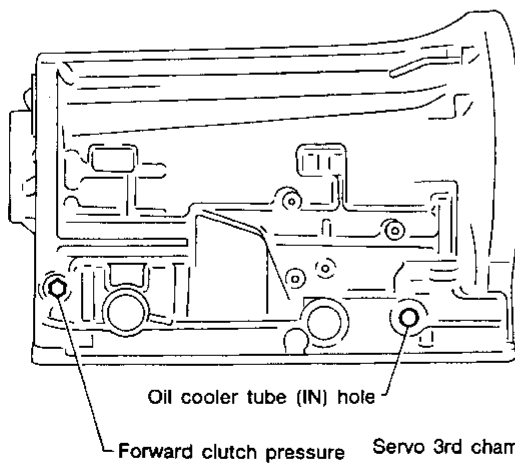
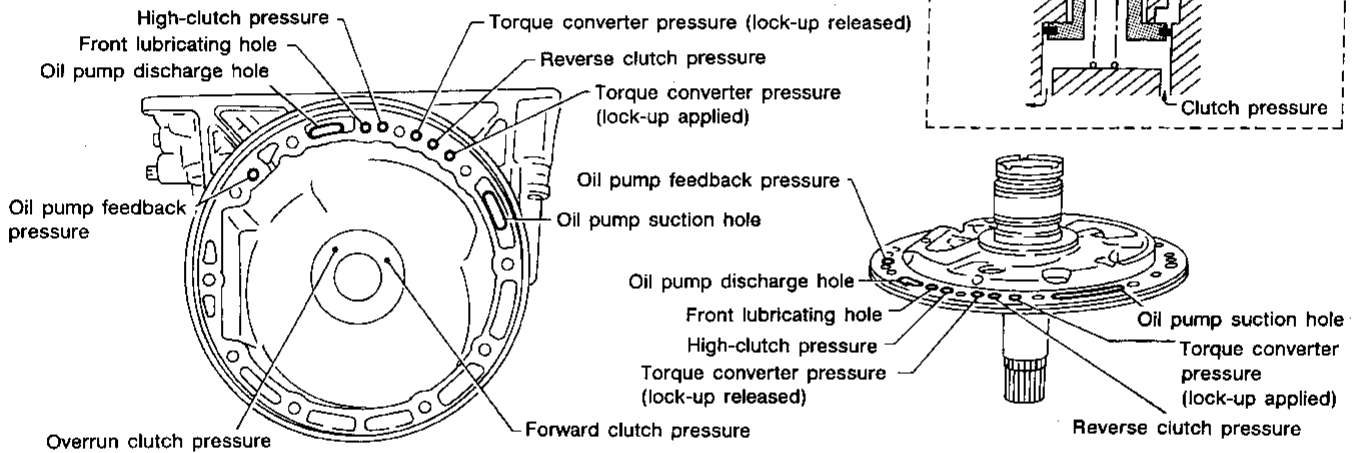
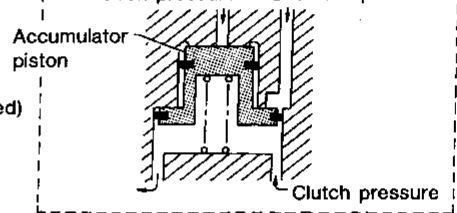
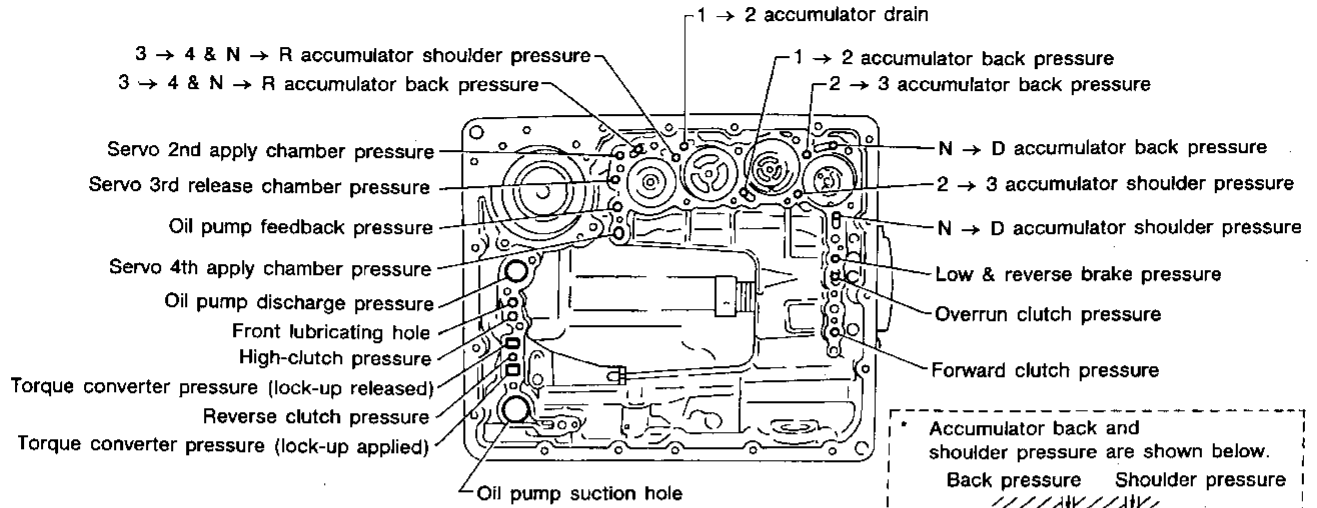

SAT185B

OVERHAUL

Locations of Needle Bearings, Thrust Washers and Snap Rings

Locations of Needle Bearings, Thrust Washers and Snap Rings

NAAT0110

Outer diameter of snap rings

Item number	Outer diameter mm (in)
②	161.0 (6.34)
③	140.1 (5.52)
④	156.4 (6.16)
⑥	142.0 (5.59)
⑦	159.2 (6.27)

Thrust washers

Item number	Color
①	Black
⑤	White

Outer diameter of needle bearings

Item number	Outer diameter mm (in)
⑧	47 (1.85)
⑨	53 (2.09)
⑪	78 (3.07)
⑫	53 (2.09)
⑬	78 (3.07)
⑭	57 (2.24)
⑮	78.1 (3.075)
⑯	64 (2.52)
⑰	53 (2.09)

Inner diameter of bearing races

Item number	Outer diameter mm (in)
⑪	58.8 (2.315)
⑬	58.8 (2.315)

Installation of one-piece bearings

Item number	Bearing race (black) location
⑩	Front
⑫	Front
⑮	Rear side
⑰	Rear side

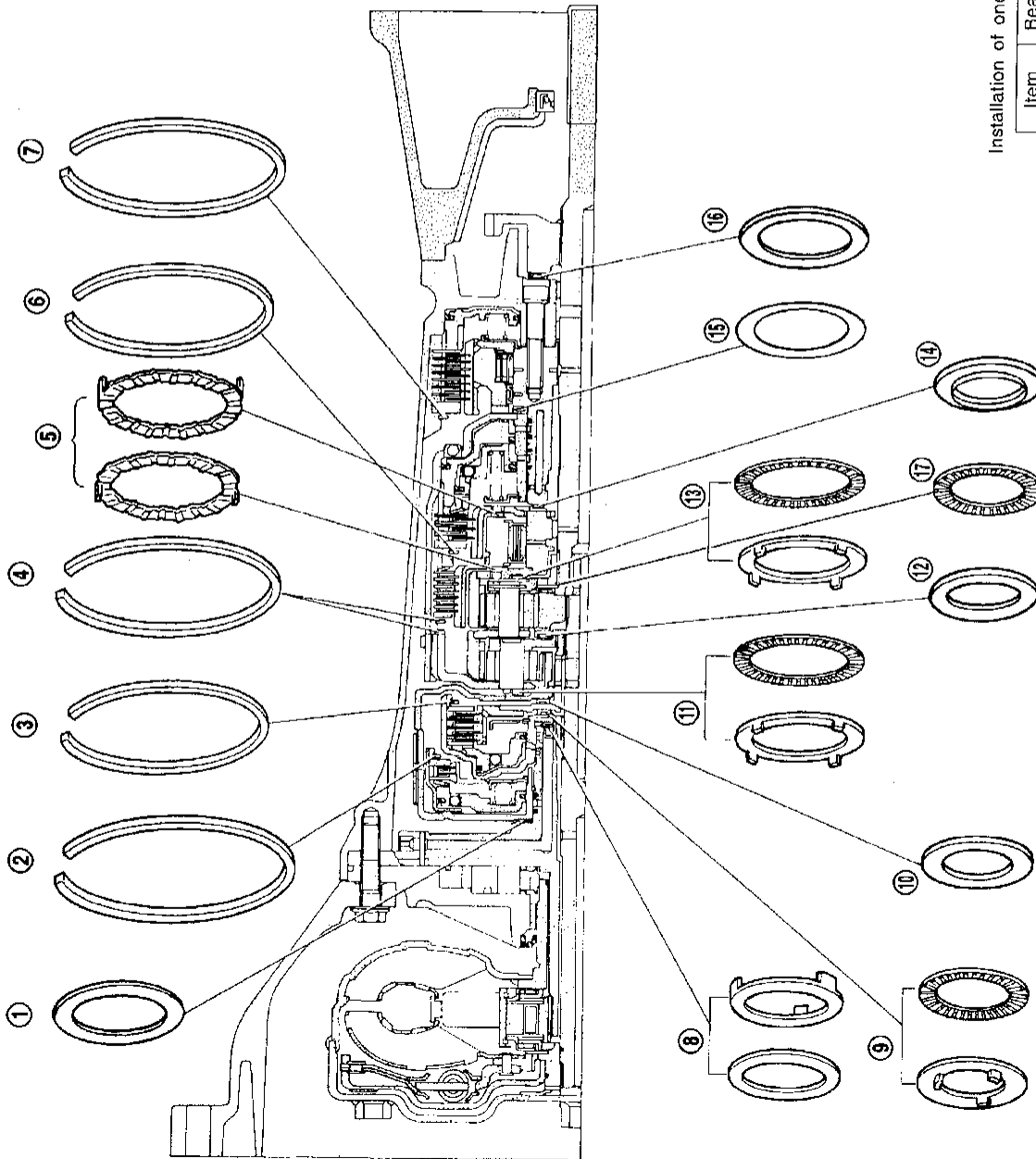

DISASSEMBLY

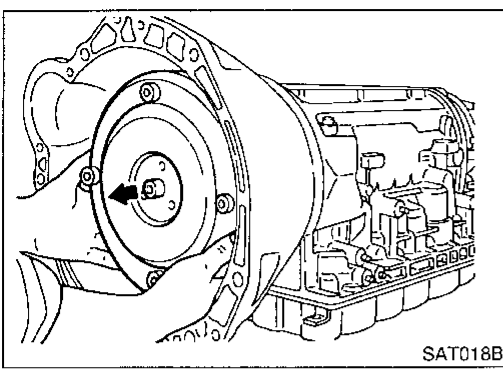

1. Drain ATF through drain plug.
2. Remove torque converter by holding it firmly and turning while pulling straight out.

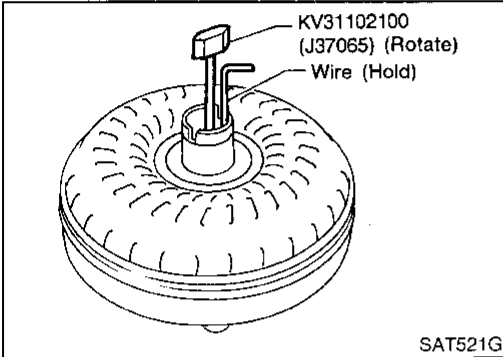

3. Check torque converter one-way clutch.
 - a. Insert Tool into spline of one-way clutch inner race.
 - b. Hook bearing support unitized with one-way clutch outer race with suitable wire.
 - c. Check that one-way clutch inner race rotates only clockwise with Tool while holding bearing support with wire.

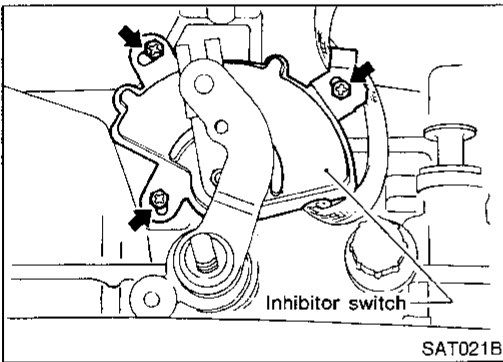

4. Remove inhibitor switch from transmission case.

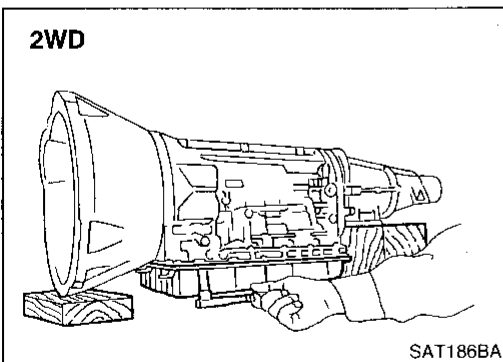

5. Remove oil pan.
 - Always place oil pan straight down so that foreign particles inside will not move.

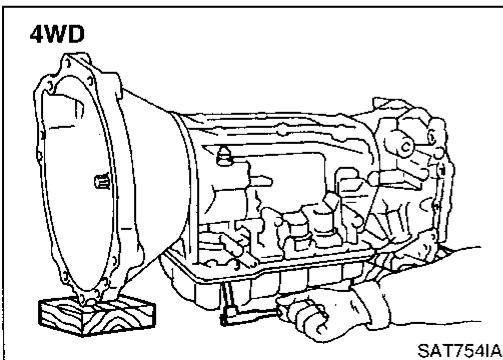

GI
MA
EM
LC
EC
FE
CL
MT
AT
TF
PD
AX
SU
BR
ST
RS
BT
HA
SC
EL
IDX

DISASSEMBLY

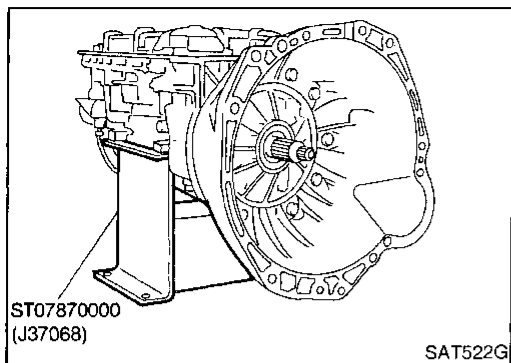

6. Place transmission into Tool with the control valve facing up.

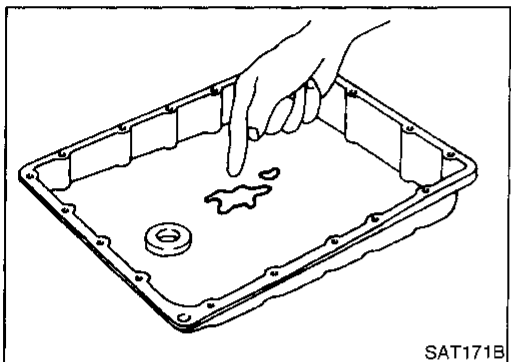

7. Check foreign materials in oil pan to help determine cause of malfunction. If the fluid is very dark, smells burned, or contains foreign particles, the frictional material (clutches, band) may need replacement. A tacky film that will not wipe clean indicates varnish build up. Varnish can cause valves, servo, and clutches to stick and may inhibit pump pressure.

- If frictional material is detected, replace radiator after repair of A/T. Refer to LC section ("Radiator", "ENGINE COOLING SYSTEM").

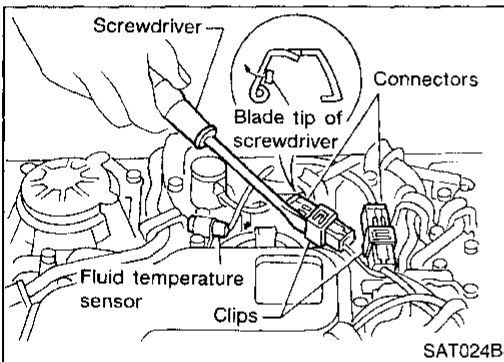

8. Remove torque converter clutch solenoid valve and fluid temperature sensor connectors.

- Be careful not to damage connector.

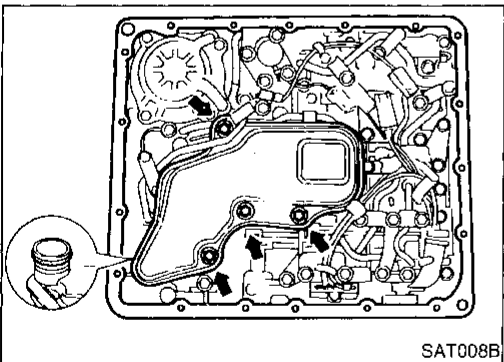

9. Remove oil strainer.

- a. Remove oil strainer from control valve assembly. Then remove O-ring from oil strainer.

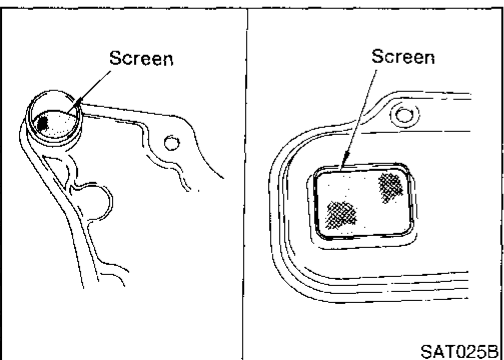

- b. Check oil strainer screen for damage.

DISASSEMBLY

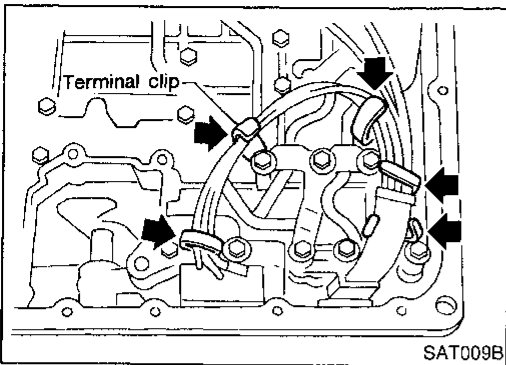

10. Remove control valve assembly.
- Straighten terminal clips to free terminal cords then remove terminal clips.

GI
MA
EM
LC

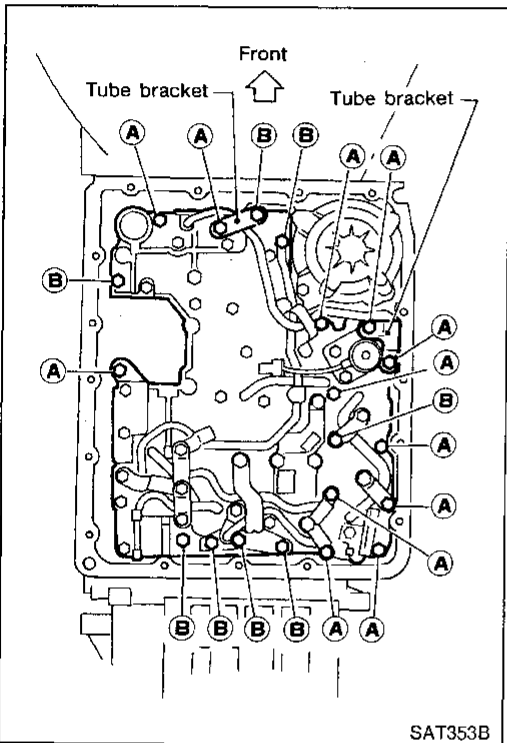

- Remove bolts A and B, and remove control valve assembly from transmission.

Bolt symbol	Length mm (in)
A	33 (1.30)
B	45 (1.77)

EC
FE
CL

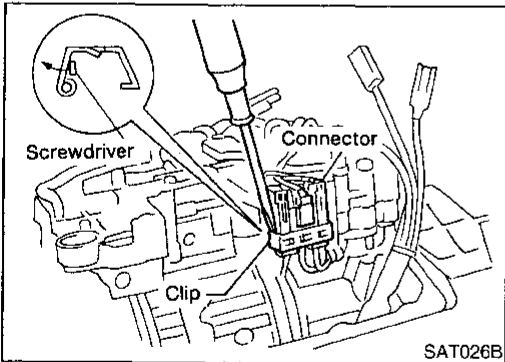

- Remove solenoid connector.
 - Be careful not to damage connector.

MT
AT

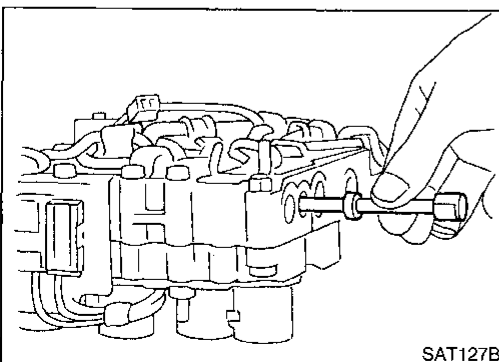

- Remove manual valve from control valve assembly.

TF
PD
AX
SU
BR
ST
RS
BT
HA
SC
EL
IDX

DISASSEMBLY

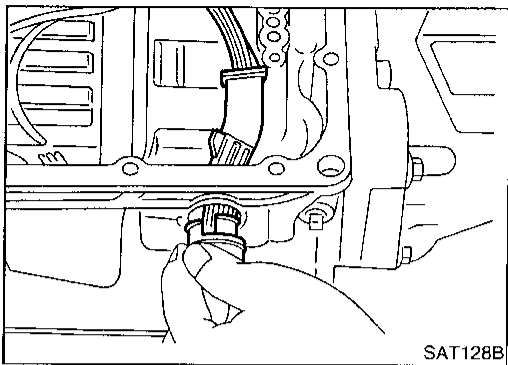

11. Remove terminal cord assembly from transmission case while pushing on stopper.
 - Be careful not to damage cord.
 - Do not remove terminal cord assembly unless it is damaged.

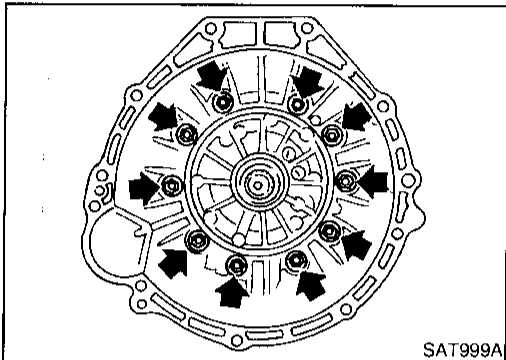

12. Remove converter housing from transmission case.
 - Be careful not to scratch converter housing.

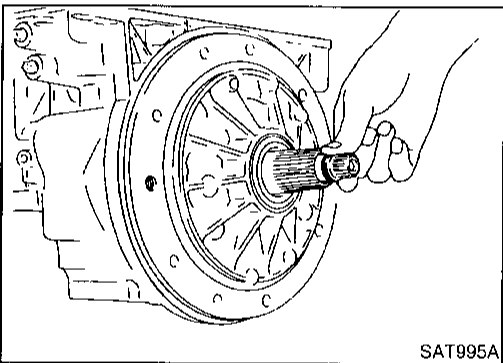

13. Remove O-ring from input shaft.

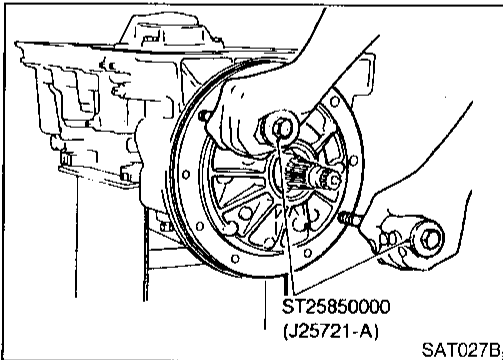

14. Remove oil pump assembly.
 - a. Attach Tool to oil pump assembly and extract it evenly from transmission case.

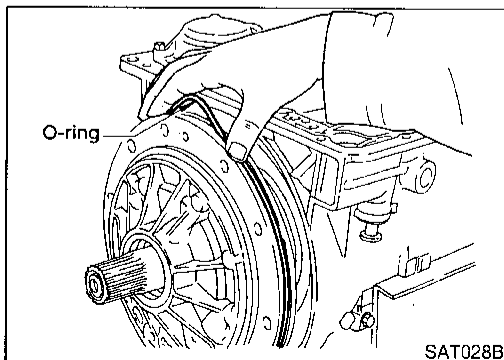

- b. Remove O-ring from oil pump assembly.
 - c. Remove traces of sealant from oil pump housing.
 - Be careful not to scratch pump housing.

DISASSEMBLY

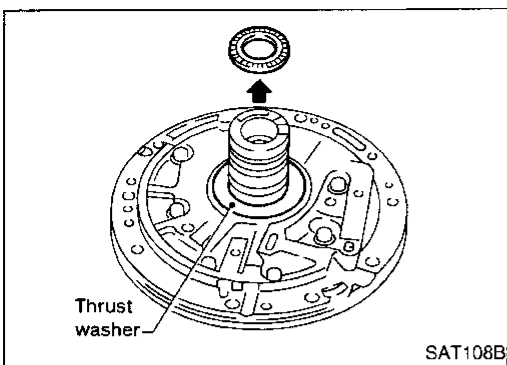

- d. Remove needle bearing and thrust washer from oil pump assembly.

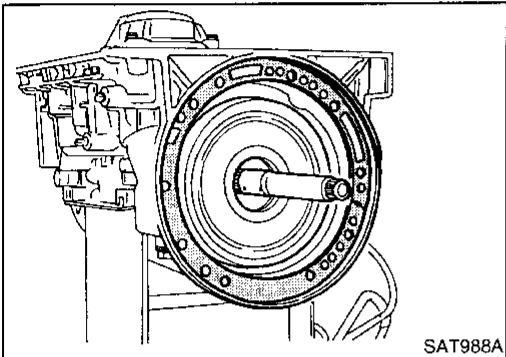

15. Remove input shaft and oil pump gasket.

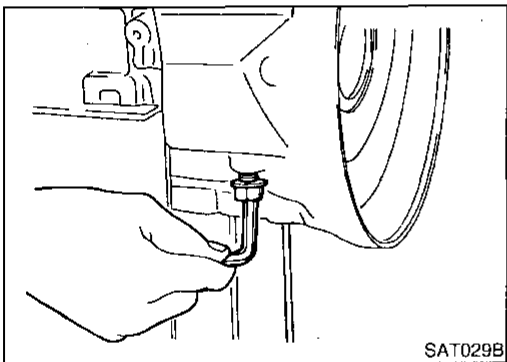

16. Remove brake band and band strut.

- a. Loosen lock nut and remove band servo anchor end pin from transmission case.

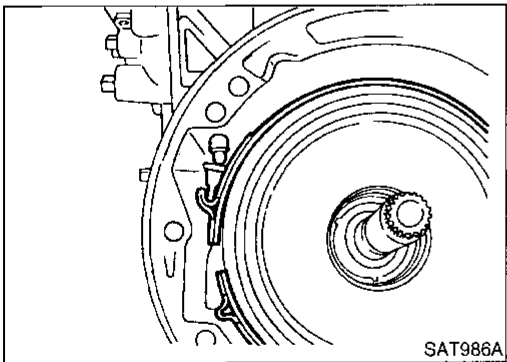

- b. Remove brake band and band strut from transmission case.

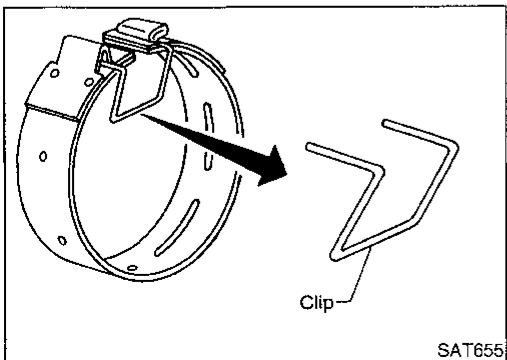

- c. Hold brake band in a circular shape with clip.

GI

MA

EM

LC

EC

FE

CL

MT

AT

TF

PD

AX

SU

BR

ST

RS

BT

HA

SC

EL

IDX

DISASSEMBLY

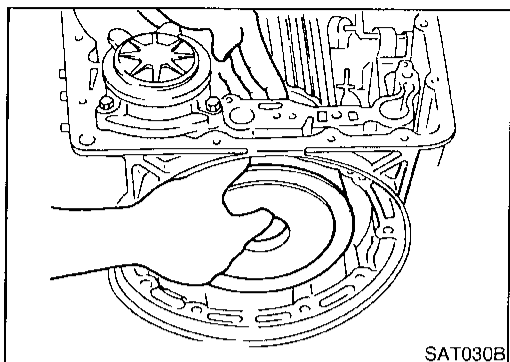

17. Remove front side clutch and gear components.
 - a. Remove clutch pack (reverse clutch, high clutch and front sun gear) from transmission case.

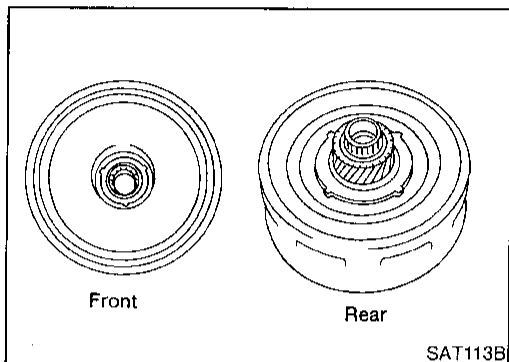

- b. Remove front bearing race from clutch pack.
 - c. Remove rear bearing race from clutch pack.

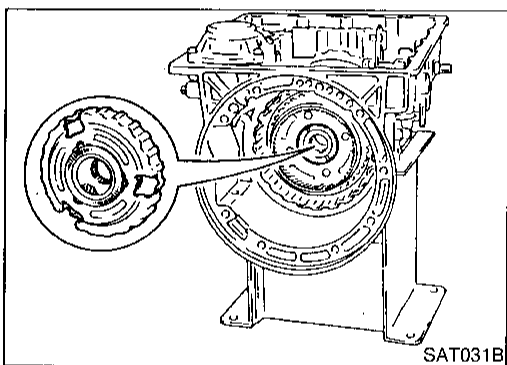

- d. Remove front planetary carrier from transmission case.

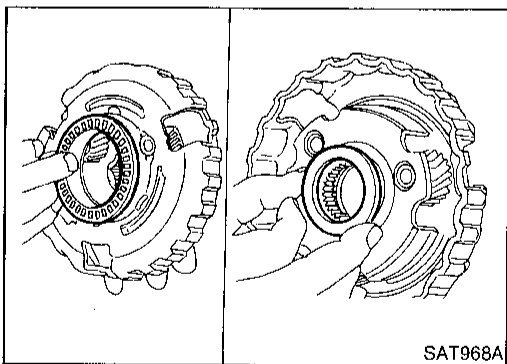

- e. Remove front needle bearing from front planetary carrier.
 - f. Remove rear bearing from front planetary carrier.

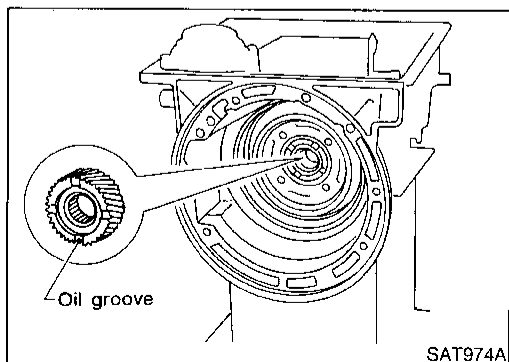

- g. Remove rear sun gear from transmission case.

DISASSEMBLY

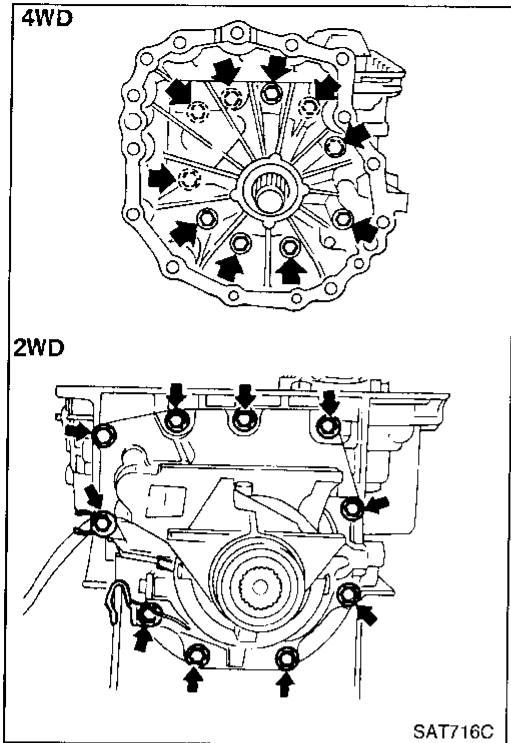

18. Remove rear extension or adapter case.
 - a. Remove rear extension or adapter case from transmission case.
 - b. Remove rear extension or adapter case gasket from transmission case.

GI
MA
EM
LC
EC
FE
CL
MT

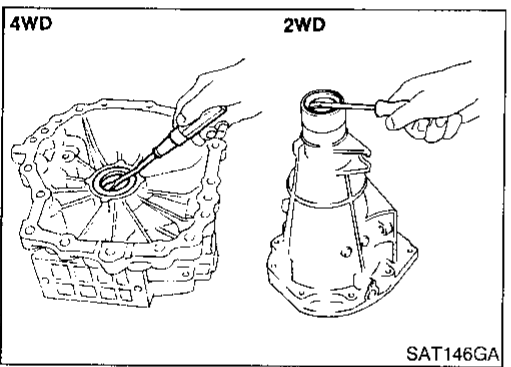

- c. Remove oil seal from rear extension or adapter case.
 - **Do not remove oil seal unless it is to be replaced.**

AT

TF
PD
AX
SU

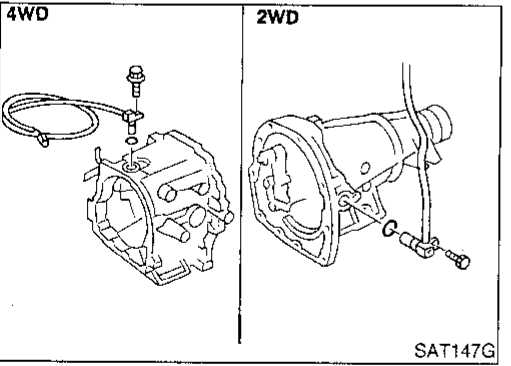

- d. Remove revolution sensor from rear extension or adapter case.
- e. Remove O-ring from revolution sensor.

BR
ST
RS
BT

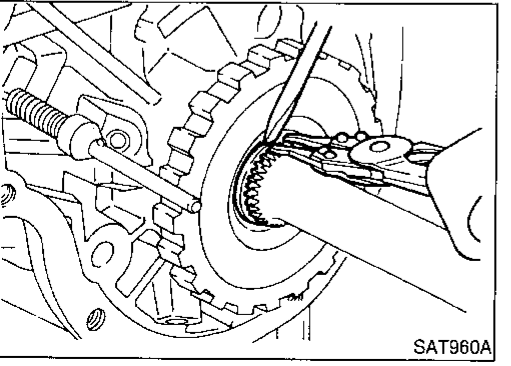

19. Remove output shaft and parking gear.
 - a. Remove rear snap ring from output shaft.

HA
SC
EL
IDX

DISASSEMBLY

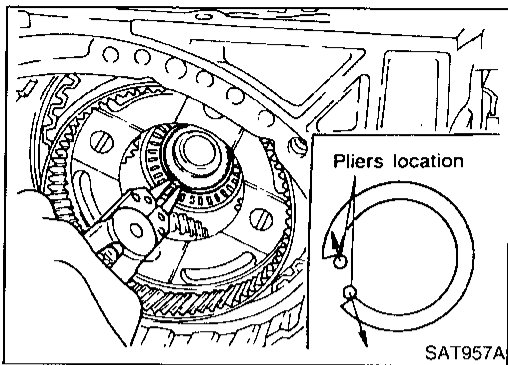

- b. Slowly push output shaft all the way forward.
- **Do not use excessive force.**
- c. Remove snap ring from output shaft.

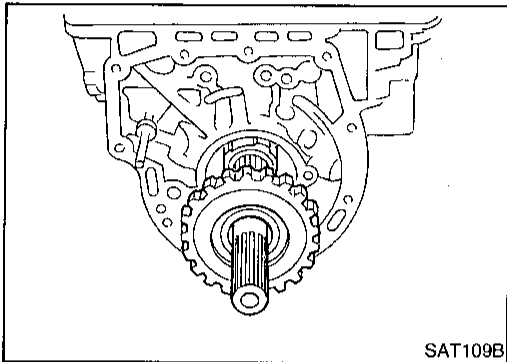

- d. Remove output shaft and parking gear as a unit from transmission case.
- e. Remove parking gear from output shaft.

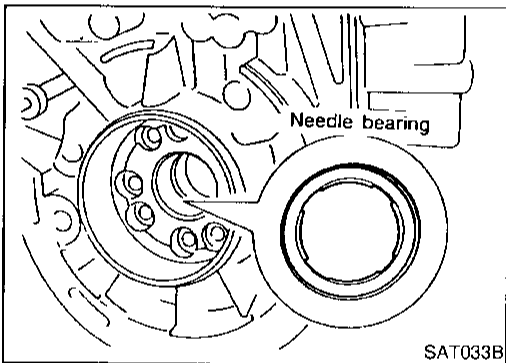

- f. Remove needle bearing from transmission case.

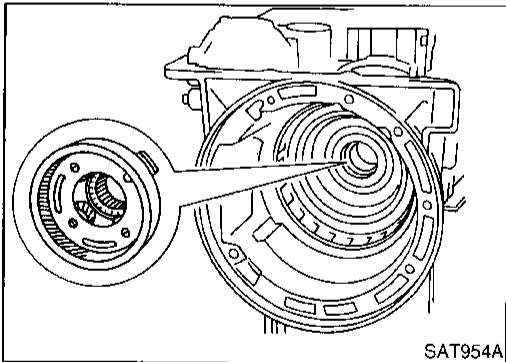

- 20. Remove rear side clutch and gear components.
- a. Remove front internal gear.

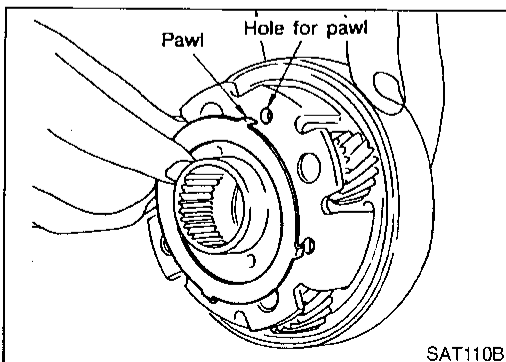

- b. Remove bearing race from front internal gear.

DISASSEMBLY

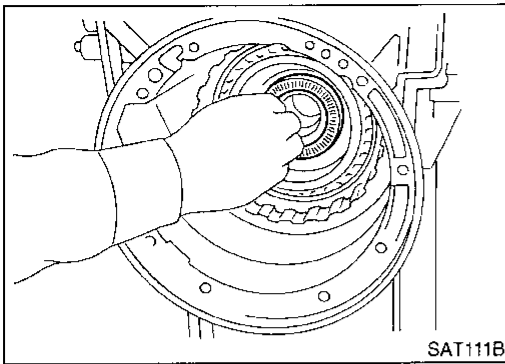

c. Remove needle bearing from rear internal gear.

GI

MA

EM

LC

EC

FE

CL

MT

AT

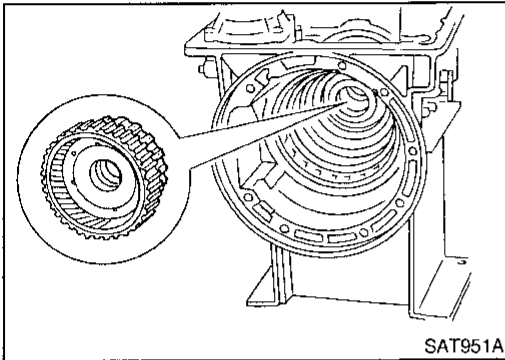

d. Remove rear internal gear, forward clutch hub and overrun clutch hub as a set from transmission case.

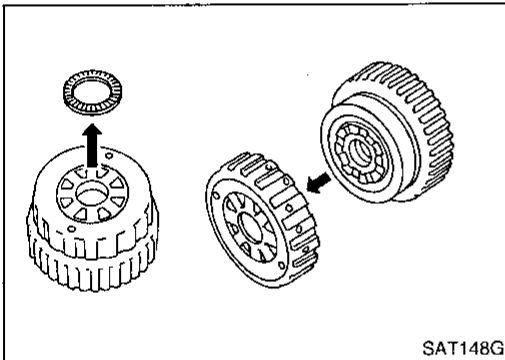

e. Remove needle bearing from overrun clutch hub.

f. Remove overrun clutch hub from rear internal gear and forward clutch hub.

TF

PD

AX

SU

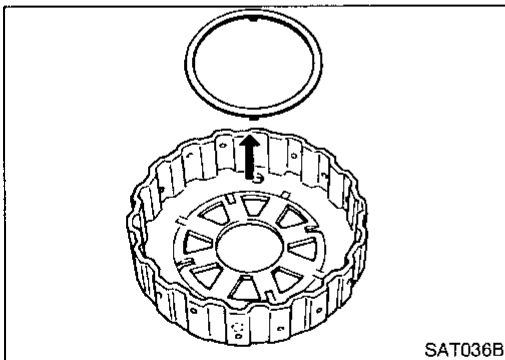

g. Remove thrust washer from overrun clutch hub.

BR

ST

RS

BT

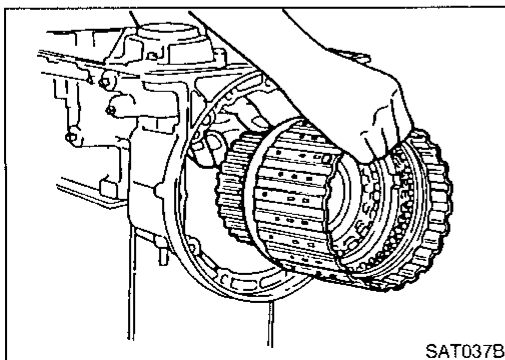

h. Remove forward clutch assembly from transmission case.

HA

SC

EL

IDX

DISASSEMBLY

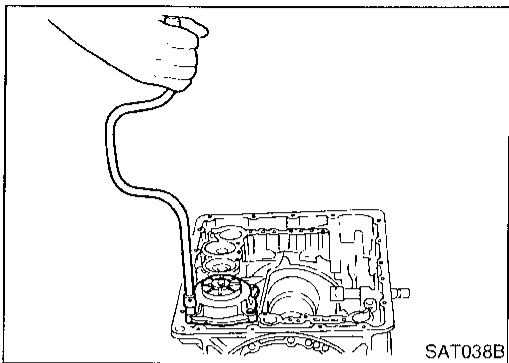

21. Remove band servo and accumulator components.
- a. Remove band servo retainer from transmission case.

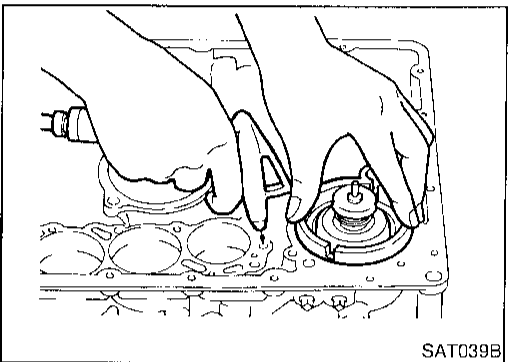

- b. Apply compressed air to oil hole until band servo piston comes out of transmission case.
 - **Hold piston with a rag and gradually direct air to oil hole.**
- c. Remove return springs.

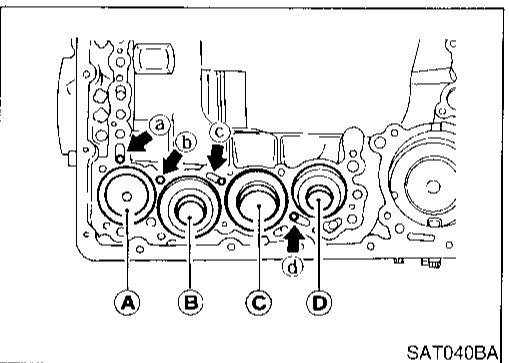

- d. Remove springs from accumulator pistons B, C and D.
- e. Apply compressed air to each oil hole until piston comes out.
 - **Hold piston with a rag and gradually direct air to oil hole.**

Identification of accumulator pistons	A	B	C	D
Identification of oil holes	a	b	c	d

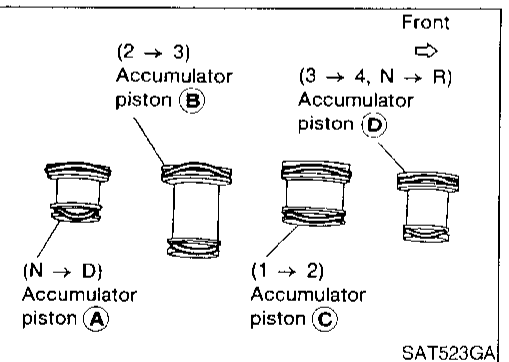

- f. Remove O-ring from each piston.

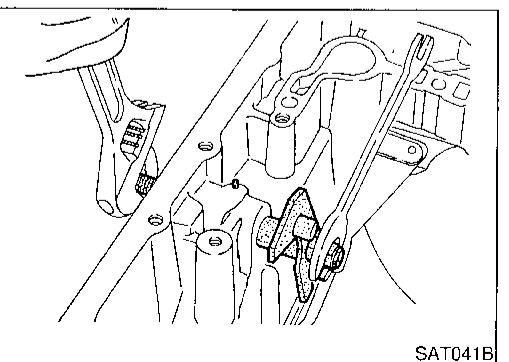

22. Remove manual shaft components, if necessary.
- a. Hold width across flats of manual shaft (outside the transmission case) and remove lock nut from shaft.

DISASSEMBLY

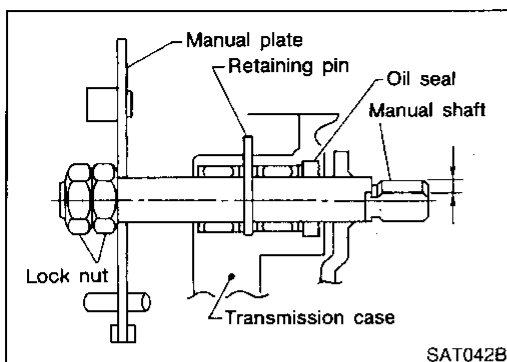

b. Remove retaining pin from transmission case.

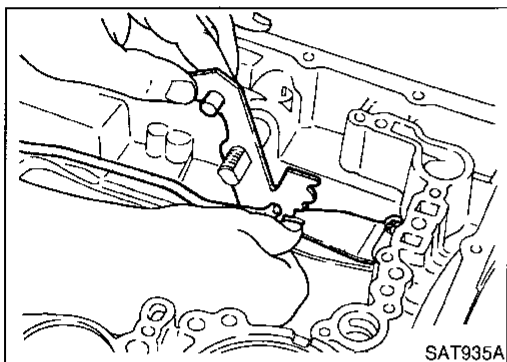

c. While pushing detent spring down, remove manual plate and parking rod from transmission case.

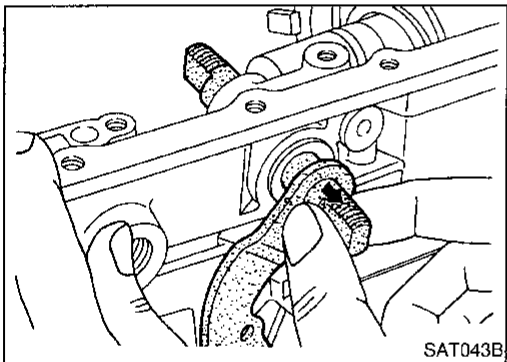

d. Remove manual shaft from transmission case.

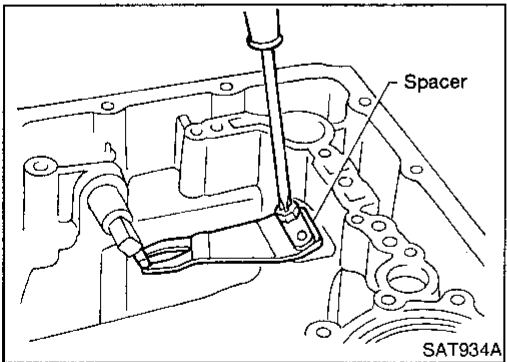

e. Remove spacer and detent spring from transmission case.

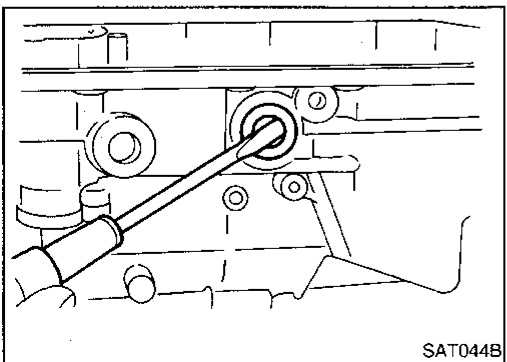

f. Remove oil seal from transmission case.

GI
MA
EM
LC
EC
FE
CL
MT
AT
TF
PD
AX
SU
BR
ST
RS
BT
HA
SC
EL
IDX

Oil Pump COMPONENTS

NAAT0112

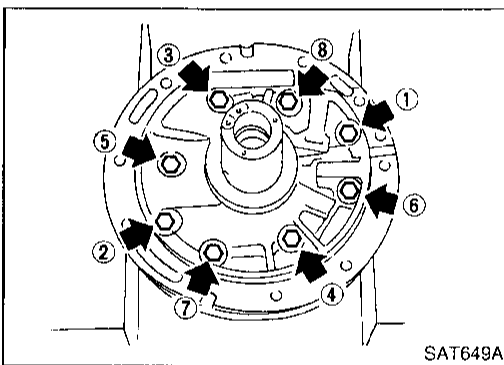
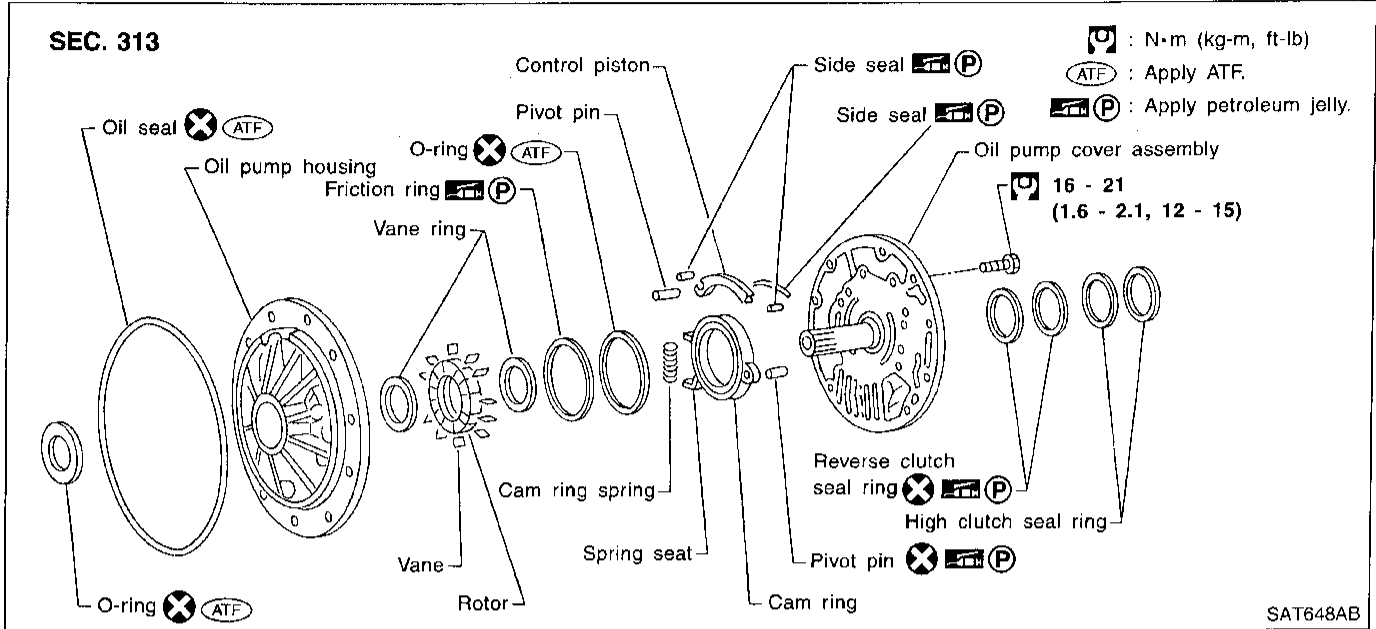

DISASSEMBLY

NAAT0113

1. Loosen bolts in numerical order and remove oil pump cover.

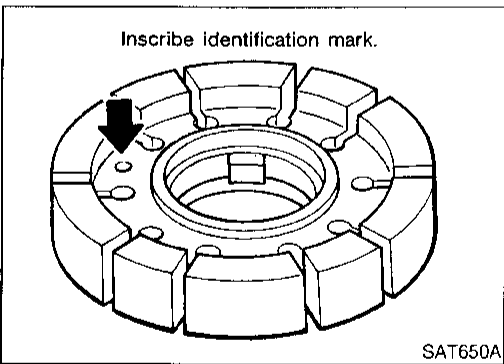

2. Remove rotor, vane rings and vanes.
 - Inscribe a mark on back of rotor for identification of fore-aft direction when reassembling rotor. Then remove rotor.

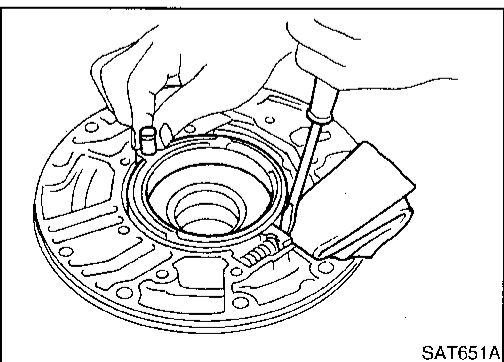

3. While pushing on cam ring remove pivot pin.
 - Be careful not to scratch oil pump housing.

REPAIR FOR COMPONENT PARTS

Oil Pump (Cont'd)

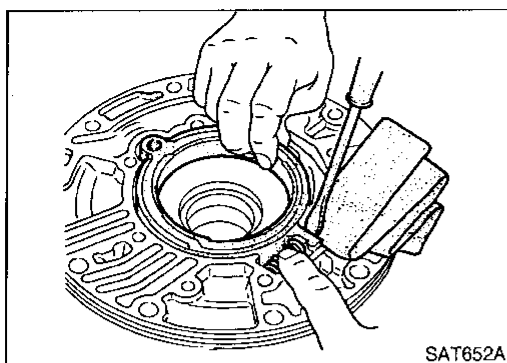

4. While holding cam ring and spring lift out cam ring spring.
 - Be careful not to damage oil pump housing.
 - Hold cam ring spring to prevent it from jumping.

GI

MA

EM

LC

EC

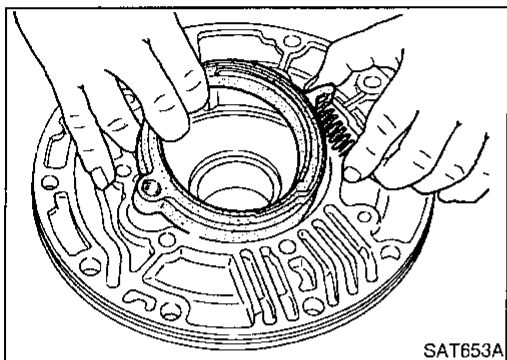

5. Remove cam ring and cam ring spring from oil pump housing.

FE

CL

MT

AT

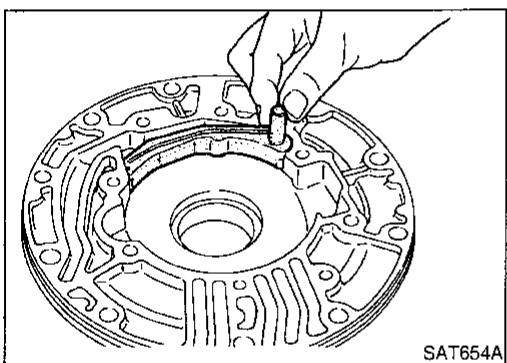

6. Remove pivot pin from control piston and remove control piston assembly.

TF

PD

AX

SU

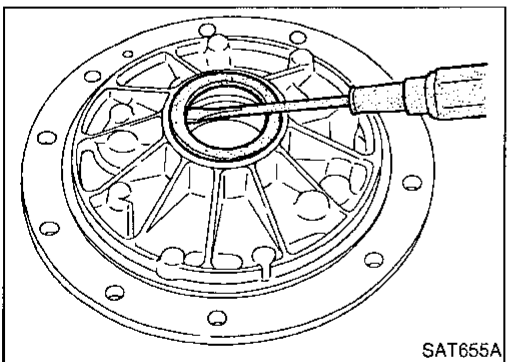

7. Remove oil seal from oil pump housing.
 - Be careful not to scratch oil pump housing.

BR

ST

RS

BT

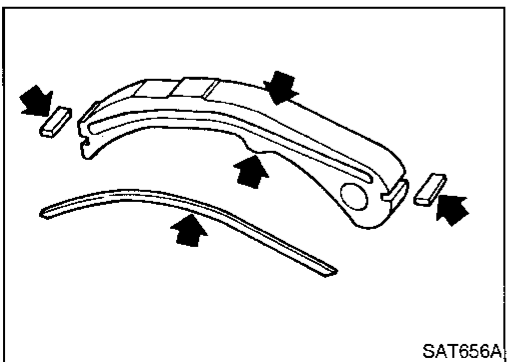

INSPECTION

Oil Pump Cover, Rotor, Vanes, Control Piston, Side

NAAT0114

HA

- Check for wear or damage.

NAAT0114S01

SC

EL

IDX

REPAIR FOR COMPONENT PARTS

Oil Pump (Cont'd)

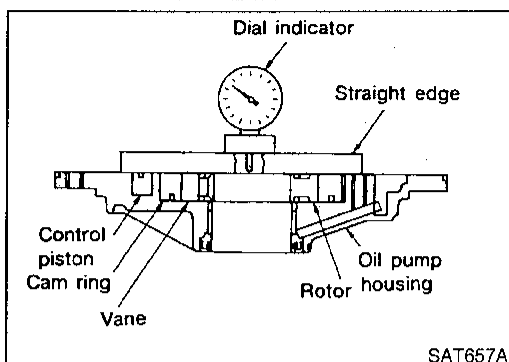

Side Clearances

NAATO114S02

- Measure side clearances between end of oil pump housing and cam ring, rotor, vanes and control piston. Measure in at least four places along their circumferences. Maximum measured values should be within specified positions.
- **Before measurement, check that friction rings, O-ring, control piston side seals and cam ring spring are removed.**

Standard clearance (Cam ring, rotor, vanes and control piston):

Refer to SDS, AT-311.

- If not within standard clearance, replace oil pump assembly except oil pump cover assembly.

Seal Ring Clearance

NAATO114S03

- Measure clearance between seal ring and ring groove.

Standard clearance:

0.10 - 0.25 mm (0.0039 - 0.0098 in)

Wear limit:

0.25 mm (0.0098 in)

- If not within wear limit, replace oil pump cover assembly.

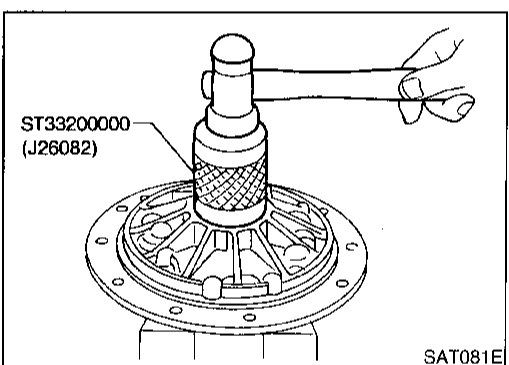
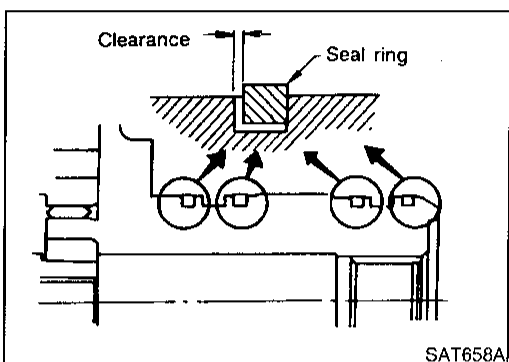

ASSEMBLY

NAATO115

1. Drive oil seal into oil pump housing.
 - **Apply ATF to outer periphery and lip surface.**

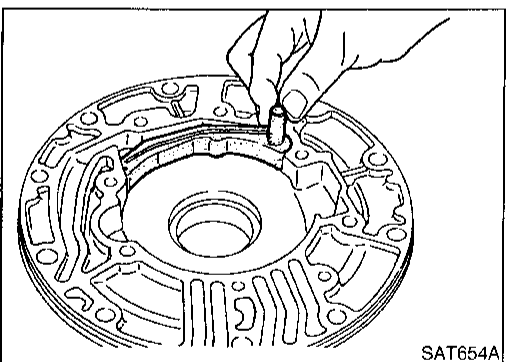

2. Install cam ring in oil pump housing by the following
 - a. Install side seal on control piston.
 - **Pay attention to its direction — Black surface goes toward control piston.**
 - **Apply petroleum jelly to side seal.**
 - b. Install control piston on oil pump.

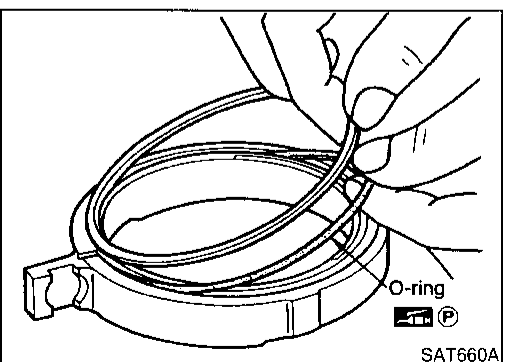

- c. Install O-ring and friction ring on cam ring.
 - **Apply petroleum jelly to O-ring.**

REPAIR FOR COMPONENT PARTS

Oil Pump (Cont'd)

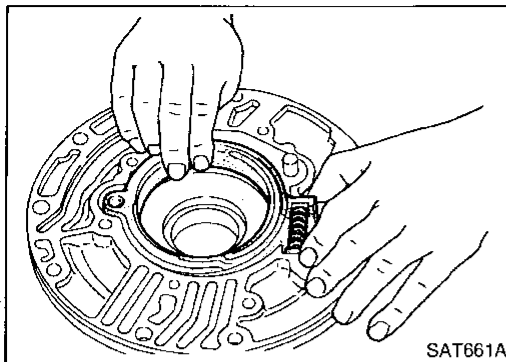

- d. Assemble cam ring, cam ring spring and spring seat. Install spring by pushing it against pump housing.

GI

MA

EM

LC

EC

FE

CL

MT

AT

TF

PD

AX

SU

BR

ST

RS

BT

HA

SC

EL

IDX

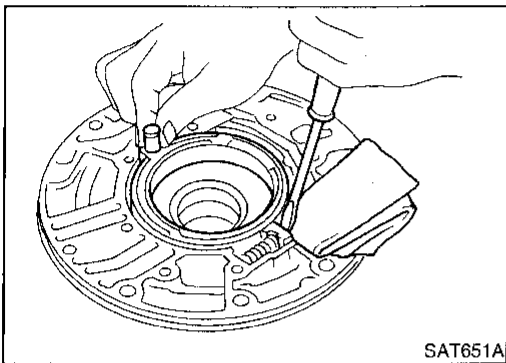

- e. While pushing on cam ring install pivot pin.

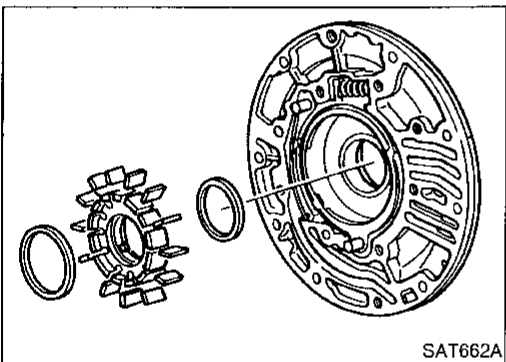

3. Install rotor, vanes and vane rings.
 • Pay attention to direction of rotor.

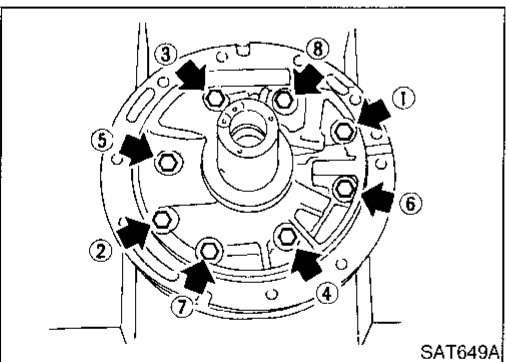

4. Install oil pump housing and oil pump cover.
 a. Wrap masking tape around splines of oil pump cover assembly to protect seal. Position oil pump cover assembly in oil pump housing assembly, then remove masking tape.
 b. Tighten bolts in a criss-cross pattern.

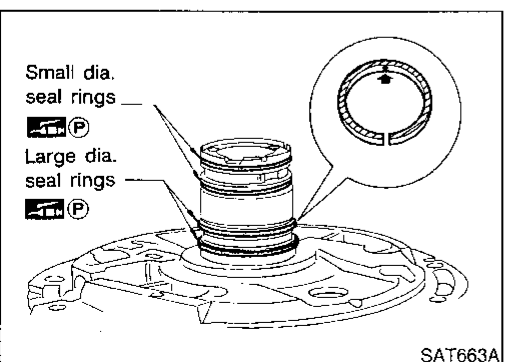

5. Install new seal rings carefully after packing ring grooves with petroleum jelly. Press rings down into jelly to a close fit.
 • Seal rings come in two different diameters. Check fit carefully in each groove.
 Small dia. seal ring:
 No mark
 Large dia. seal ring:
 Yellow mark in area shown by arrow
 • Do not spread gap of seal ring excessively while installing. It may deform ring.

REPAIR FOR COMPONENT PARTS

Control Valve Assembly COMPONENTS

NAAT0116

SEC. 317

 10 - 13
(1.0 - 1.3, 87 - 113)

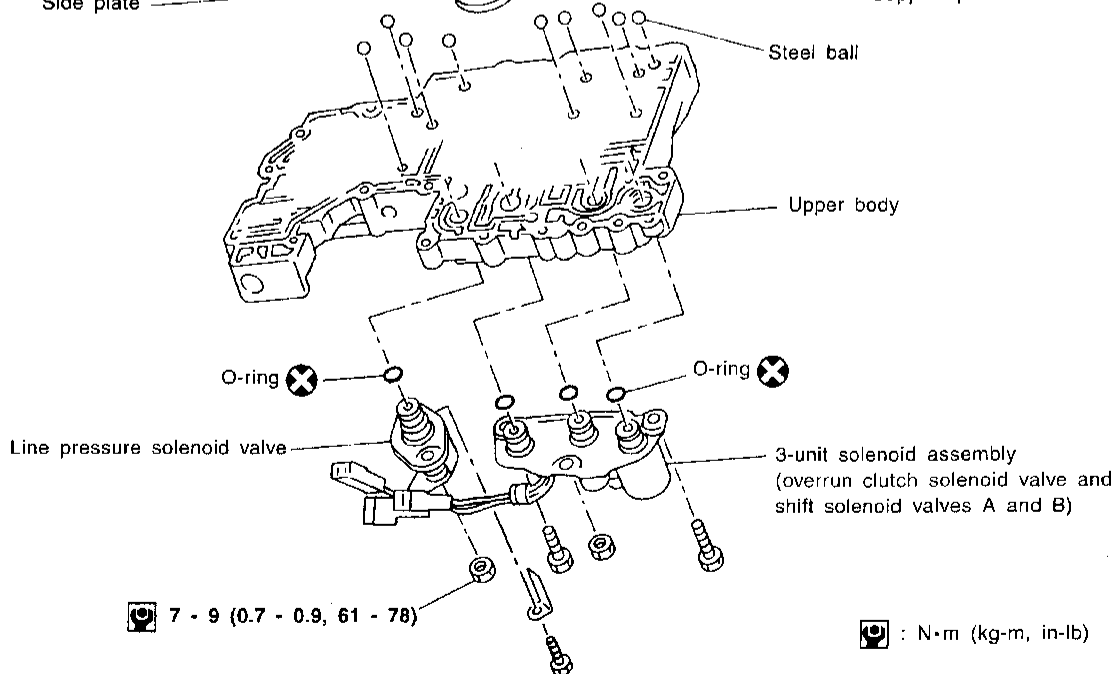
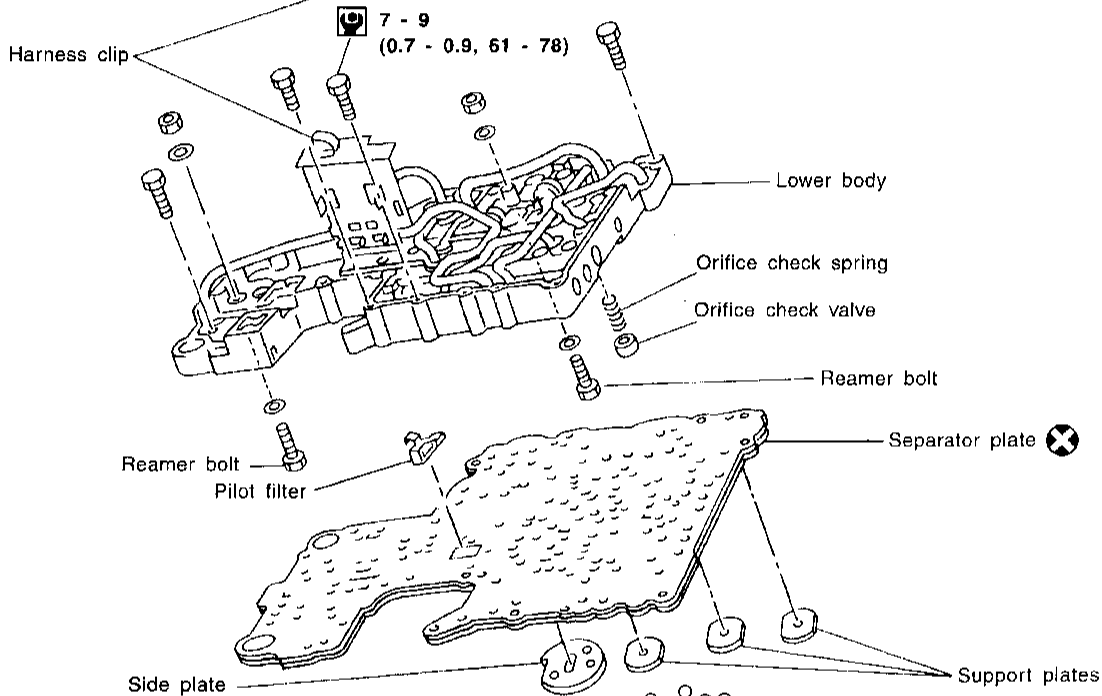
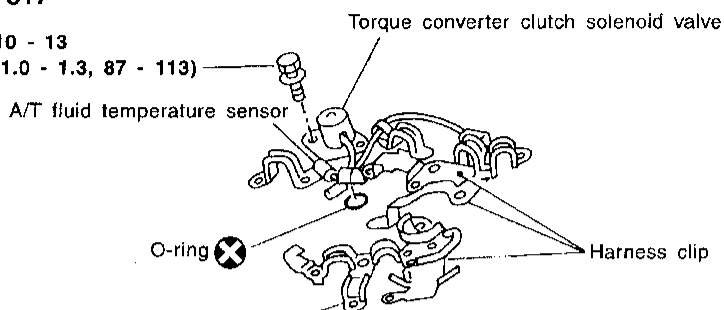

 : N·m (kg-m, in-lb)

SAT141J

REPAIR FOR COMPONENT PARTS

Control Valve Assembly (Cont'd)

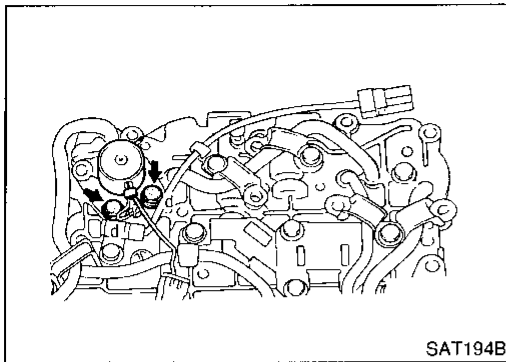

SAT194B

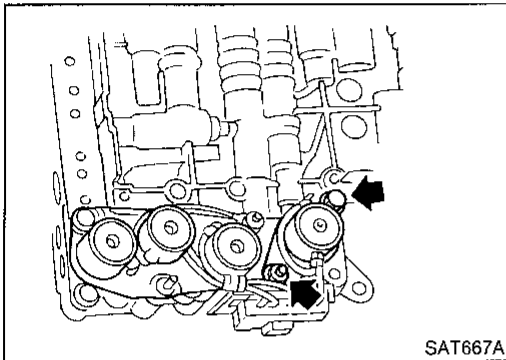

SAT667A

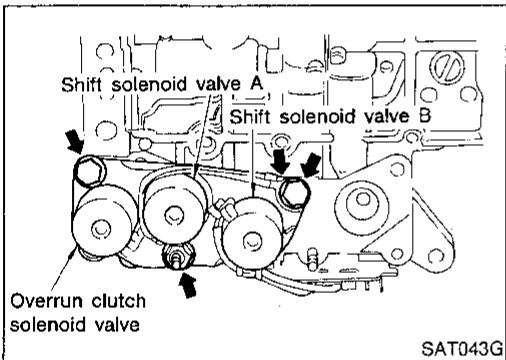

SAT043G

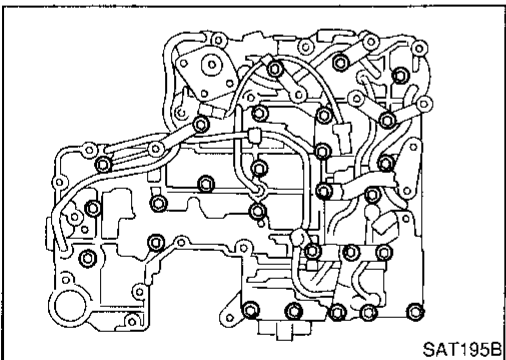

SAT195B

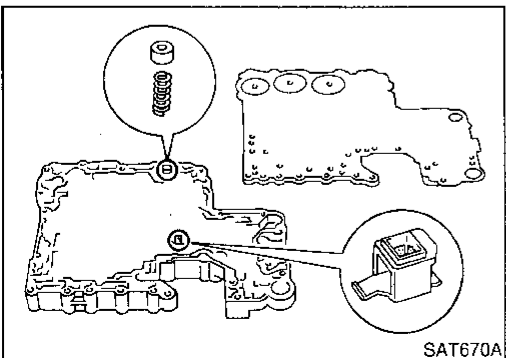

SAT670A

DISASSEMBLY

NAAT0117

1. Remove solenoids.
 - a. Remove torque converter clutch solenoid valve and side plate from lower body.
 - b. Remove O-ring from solenoid.
 - c. Remove line pressure solenoid valve from upper body.
 - d. Remove O-ring from solenoid.
 - e. Remove 3-unit solenoid assembly from upper body.
 - f. Remove O-rings from solenoids.
2. Disassemble upper and lower bodies.
 - a. Place upper body facedown, and remove bolts, reamer bolts and support plates.
 - b. Remove lower body, separator plate and separate gasket as a unit from upper body.
 - **Be careful not to drop pilot filter, orifice check valve, spring and steel balls.**
 - c. Place lower body facedown, and remove separate gasket and separator plate.
 - d. Remove pilot filter, orifice check valve and orifice check spring.

GI
MA
EM
LC
EC
FE
CL
MT
AT
TF
PD
AX
SU
BR
ST
RS
BT
HA
SC
EL
IDX

REPAIR FOR COMPONENT PARTS

Control Valve Assembly (Cont'd)

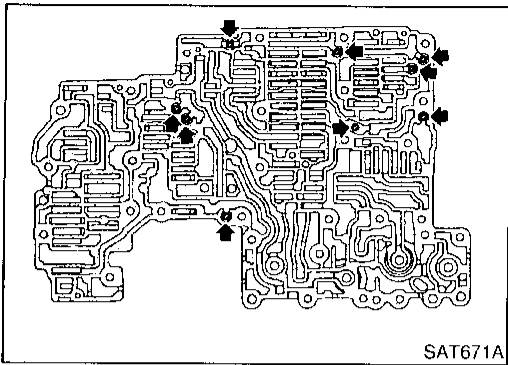

- e. Check to see that steel balls are properly positioned in upper body. Then remove them from upper body.

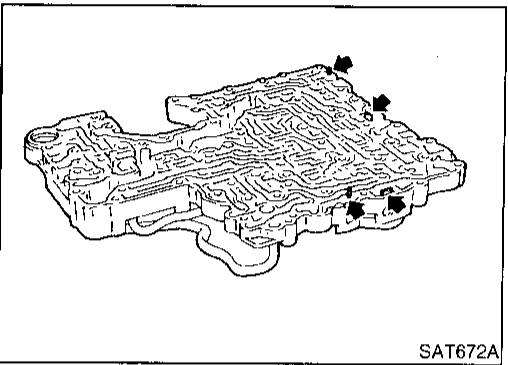

INSPECTION

Lower and Upper Bodies

NAAT0118

NAAT0118S01

- Check to see that there are pins and retainer plates in lower body.

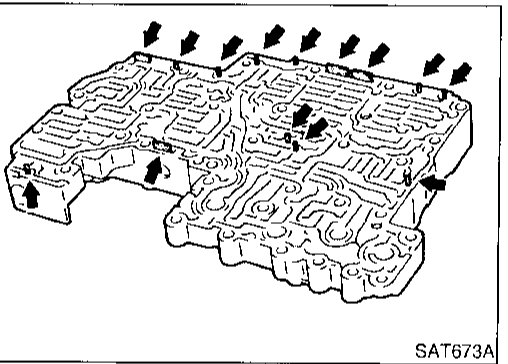

- Check to see that there are pins and retainer plates in upper body.
- **Be careful not to lose these parts.**

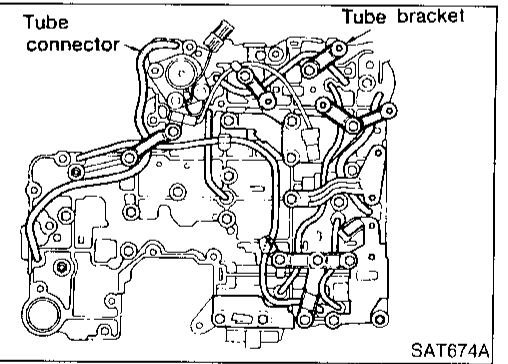

- Check to make sure that oil circuits are clean and free from damage.
- Check tube brackets and tube connectors for damage.

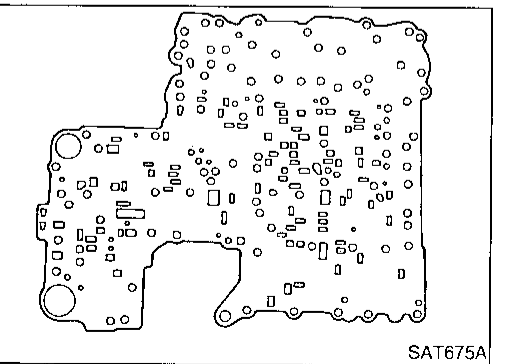

Separator Plates

NAAT0118G02

- Make sure that separator plate is free of damage and not deformed and oil holes are clean.

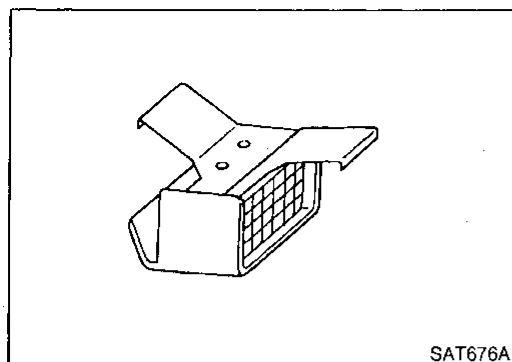

SAT676A

Pilot Filter

NAAT0118S03

- Check to make sure that filter is not clogged or damaged.

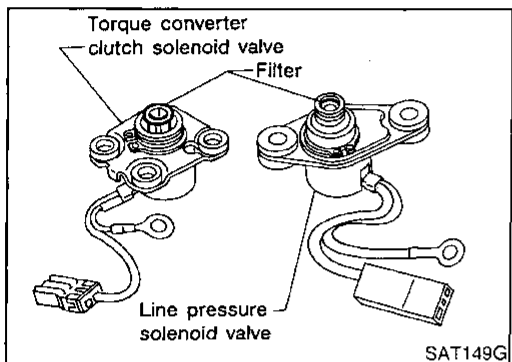

SAT149G

Torque Converter Clutch Solenoid Valve

NAAT0118S04

- Check that filter is not clogged or damaged.
- Measure resistance. Refer to "Component Inspection", AT-131.

Line Pressure Solenoid Valve

NAAT0118S05

- Check that filter is not clogged or damaged.
- Measure resistance. Refer to "Component Inspection", AT-131.

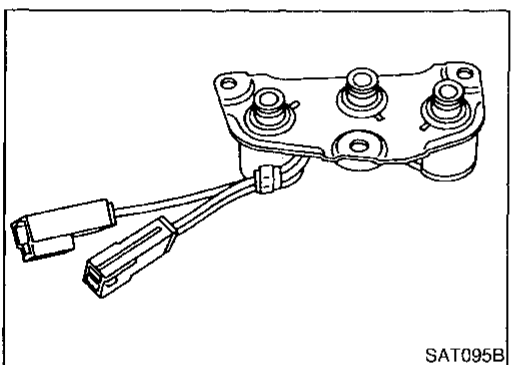

SAT095B

3-Unit Solenoid Assembly (Overrun Clutch Solenoid Valve and Shift Solenoid Valves A and B)

NAAT0118S06

- Measure resistance of each solenoid. Refer to "Component Inspection", AT-131.

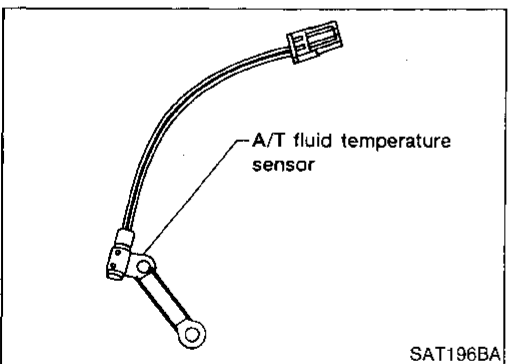

SAT196BA

A/T Fluid Temperature Sensor

NAAT0118S07

- Measure resistance. Refer to "Component Inspection", AT-95.

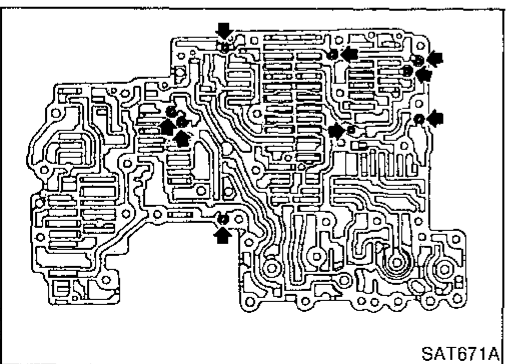

SAT671A

ASSEMBLY

NAAT0119

1. Install upper and lower bodies.
 - a. Place oil circuit of upper body face up. Install steel balls in their proper positions.

GI
MA
EM
LC
EC
FE
CL
MT
AT
TF
PD
AX
SU
BR
ST
RS
BT
HA
SC
EL
IDX

REPAIR FOR COMPONENT PARTS

Control Valve Assembly (Cont'd)

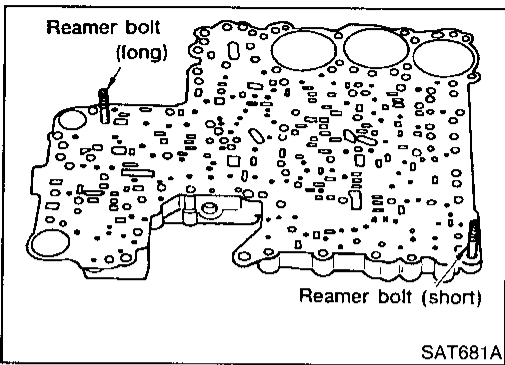

- b. Install reamer bolts from bottom of upper body and install separate gaskets.

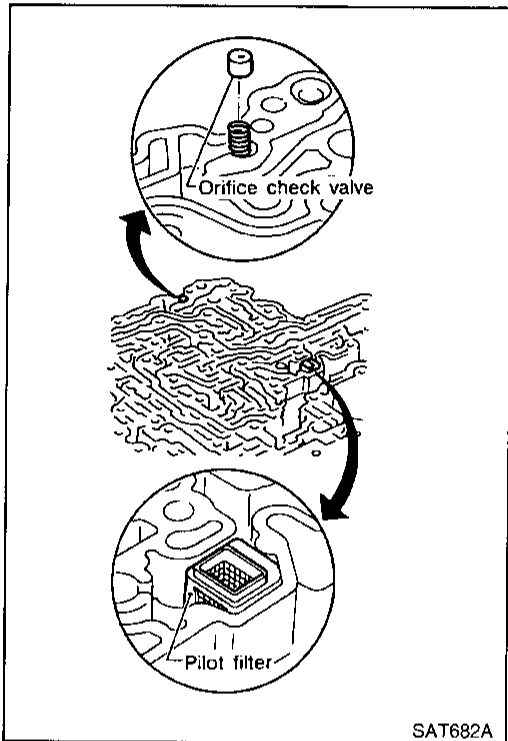

- c. Place oil circuit of lower body face up. Install orifice check spring, orifice check valve and pilot filter.

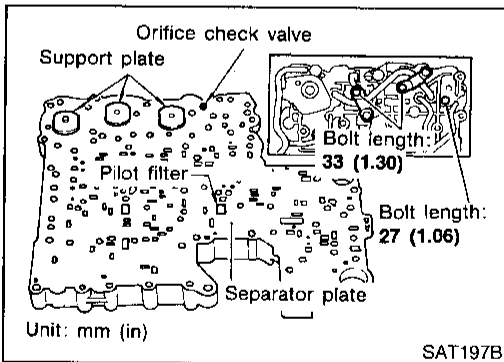

- d. Install lower separate gaskets and separator plates on lower body.
- e. Install and temporarily tighten support plates, fluid temperature sensor and tube brackets.

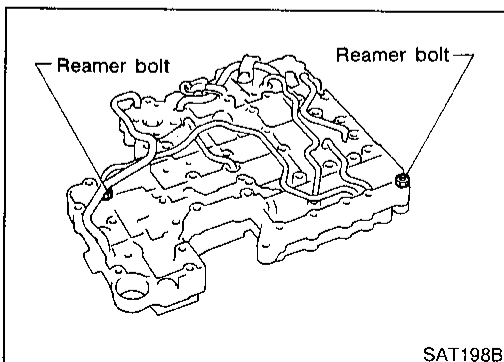

- f. Temporarily assemble lower and upper bodies, using reamer bolt as a guide.
- Be careful not to dislocate or drop steel balls, orifice check spring, orifice check valve and pilot filter.

REPAIR FOR COMPONENT PARTS

Control Valve Assembly (Cont'd)

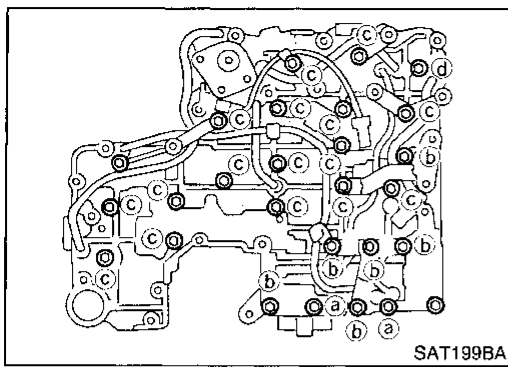

- g. Install and temporarily tighten bolts and tube brackets in their proper locations.

Bolt length and location:

Bolt symbol	a	b	c	d
Bolt length mm (in)	70 (2.76)	50 (1.97)	33 (1.30)	27 (1.06)

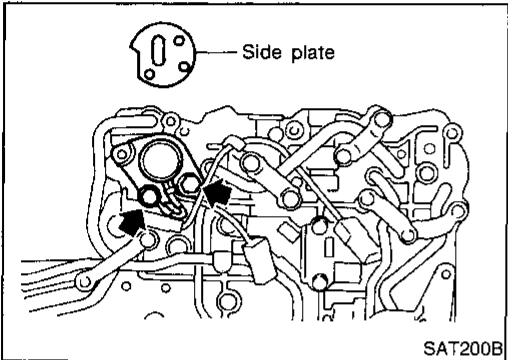

2. Install solenoids.
 a. Attach O-ring and install torque converter clutch solenoid valve and side plates onto lower body.

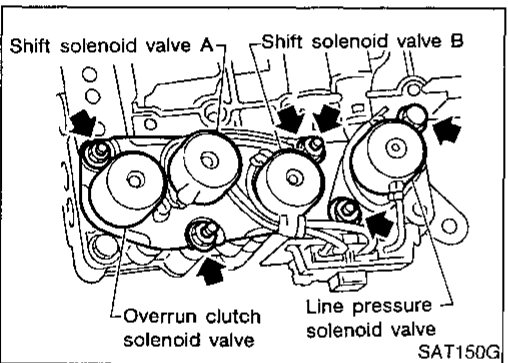

- b. Attach O-rings and install 3-unit solenoids assembly onto upper body.
 c. Attach O-ring and install line pressure solenoid valve onto upper body.
 3. Tighten all bolts.

GI
 MA
 EM
 LC
 EC
 FE
 CL
 MT
 AT
 TF
 PD
 AX
 SU
 BR
 ST
 RS
 BT
 HA
 SC
 EL
 IDX

Control Valve Upper Body

COMPONENTS

NAA10120

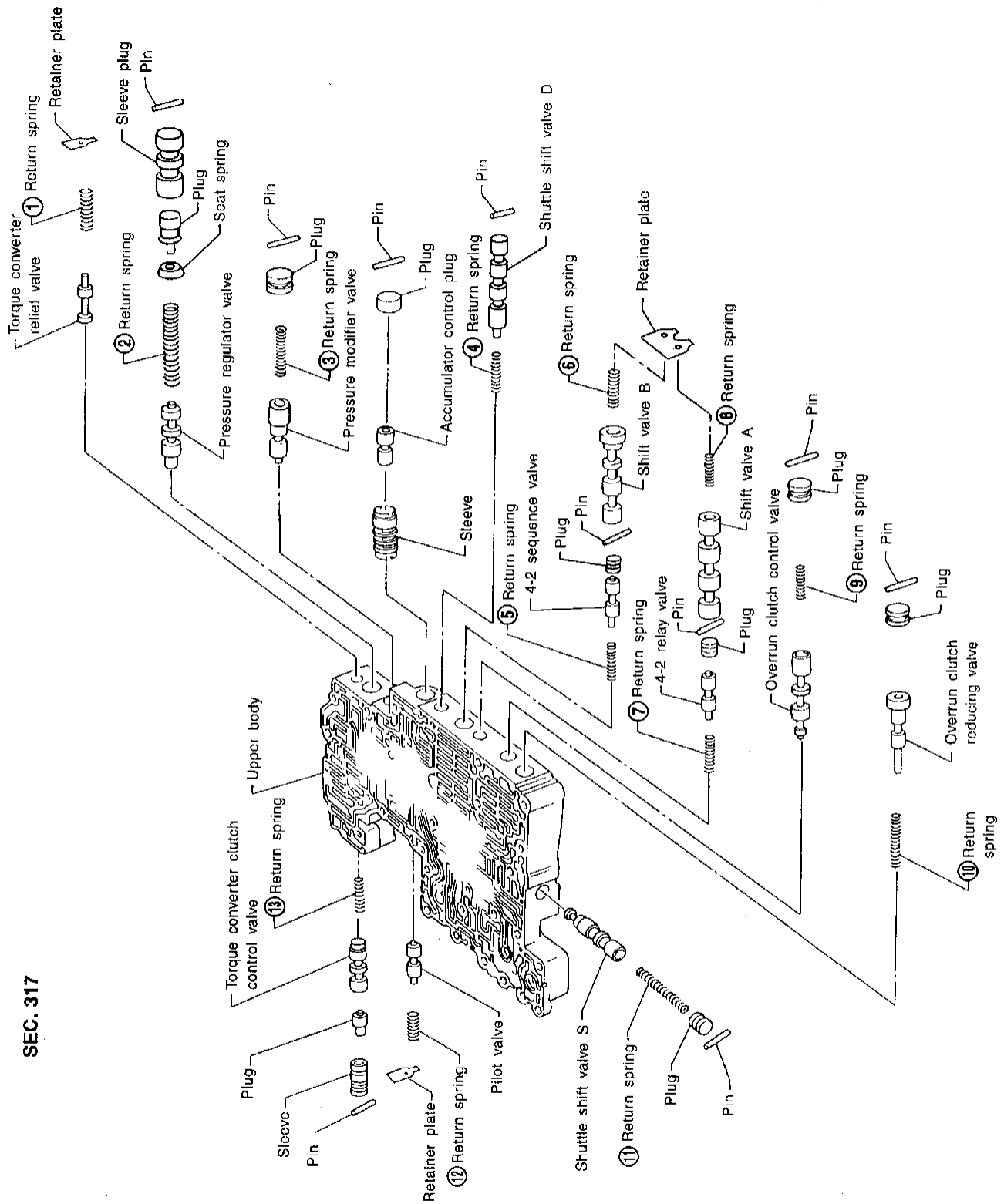

SEC. 317

SAT142J

Apply ATF to all components before their installation.
 Numbers preceding valve springs correspond with those shown in SDS on page AT-308.

REPAIR FOR COMPONENT PARTS

Control Valve Upper Body (Cont'd)

NAAT0121

GI
MA
EM
LC
EC
FE
CL
MT
AT
TF
PD
AX
SU
BR
ST
RS
BT
HA
SC
EL
IDX

DISASSEMBLY

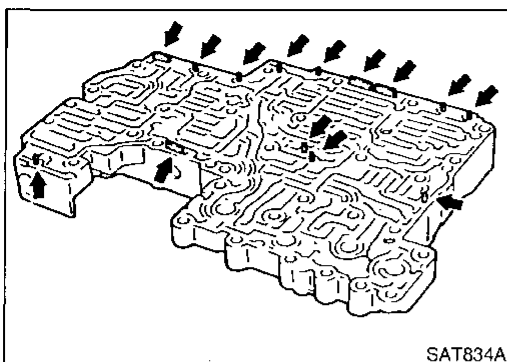

1. Remove valves at parallel pins.
 - Do not use a magnetic hand.

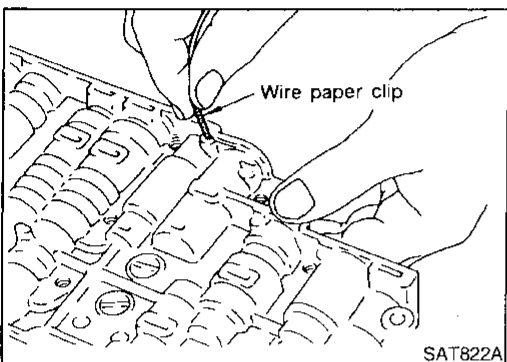

- a. Use a wire paper clip to push out parallel pins.

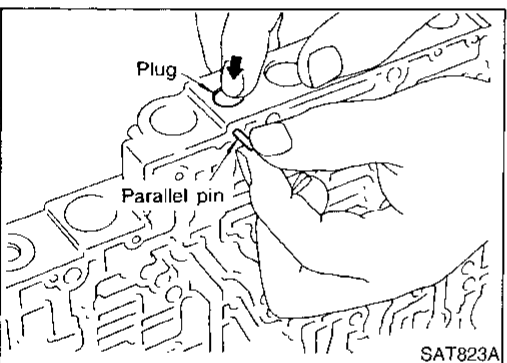

- b. Remove parallel pins while pressing their corresponding plugs and sleeves.
 - Remove plug slowly to prevent internal parts from jumping out.

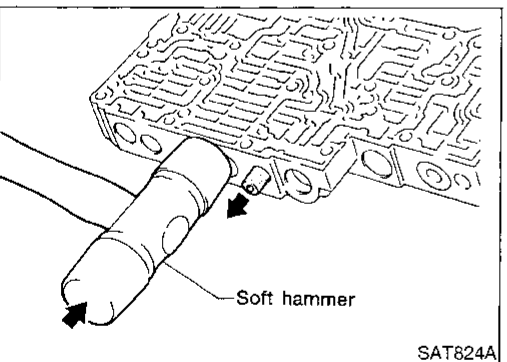

- c. Place mating surface of valve facedown, and remove internal parts.
 - If a valve is hard to remove, place valve body facedown and lightly tap it with a soft hammer.
 - Be careful not to drop or damage valves and sleeves.

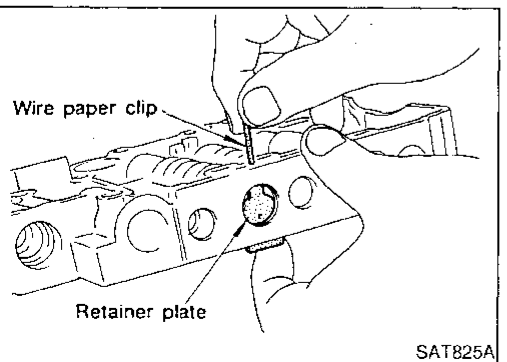

2. Remove valves at retainer plates.
 - a. Pry out retainer plate with wire paper clip.

REPAIR FOR COMPONENT PARTS

Control Valve Upper Body (Cont'd)

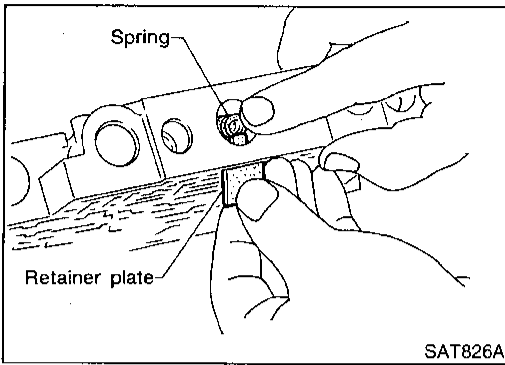

b. Remove retainer plates while holding spring.

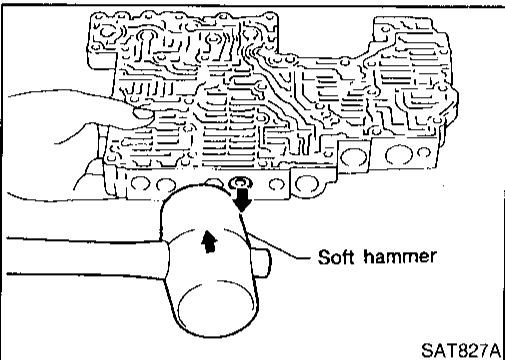

c. Place mating surface of valve facedown, and remove internal parts.

- If a valve is hard to remove, lightly tap valve body with a soft hammer.
- Be careful not to drop or damage valves, sleeves, etc.

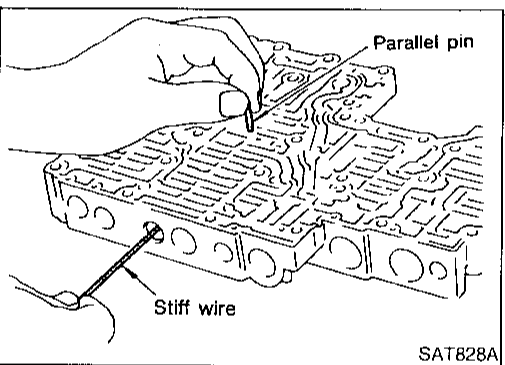

- 4-2 sequence valve and relay valve are located far back in upper body. If they are hard to remove, carefully push them out using stiff wire.
- Be careful not to scratch sliding surface of valve with wire.

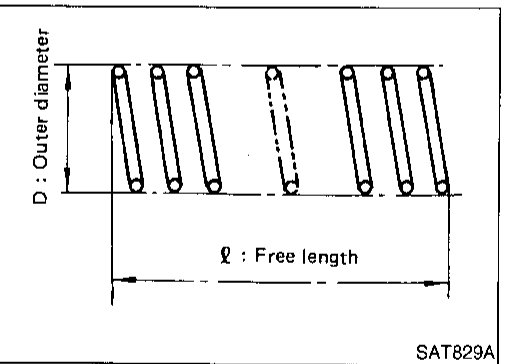

INSPECTION

Valve Springs

NAAT0122

NAAT0122S01

- Measure free length and outer diameter of each valve spring. Also check for damage or deformation.

Inspection standard:

Refer to SDS, AT-308.

- Replace valve springs if deformed or fatigued.

Control Valves

NAAT0122S02

- Check sliding surfaces of valves, sleeves and plugs.

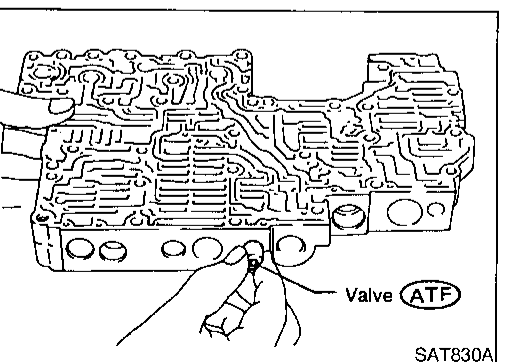

ASSEMBLY

NAAT0123

1. Lubricate the control valve body and all valves with ATF. Install control valves by sliding them carefully into their bores.
- Be careful not to scratch or damage valve body.

REPAIR FOR COMPONENT PARTS

Control Valve Upper Body (Cont'd)

GI

MA

EM

LC

EC

FE

CL

MT

AT

TF

PD

AX

SU

BR

ST

RS

BT

HA

SC

EL

IDX

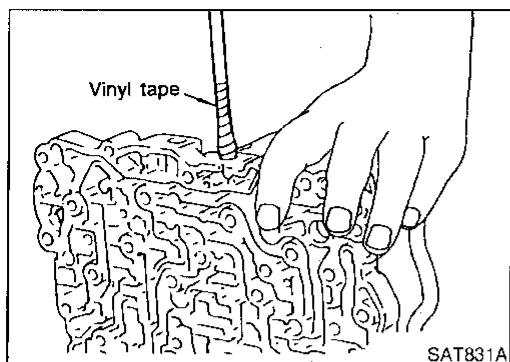

- Wrap a small screwdriver with vinyl tape and use it to insert the valves into proper position.

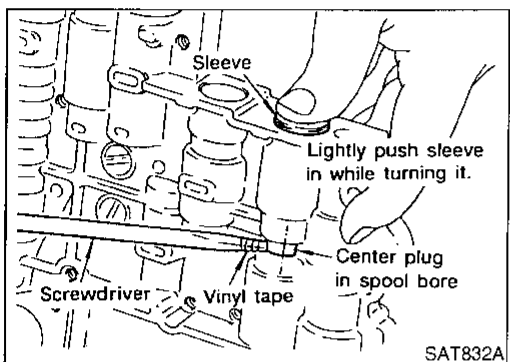

Pressure regulator valve

- If pressure regulator plug is not centered properly, sleeve cannot be inserted into bore in upper body. If this happens, use vinyl tape wrapped screwdriver to center sleeve until it can be inserted.
- Turn sleeve slightly while installing.

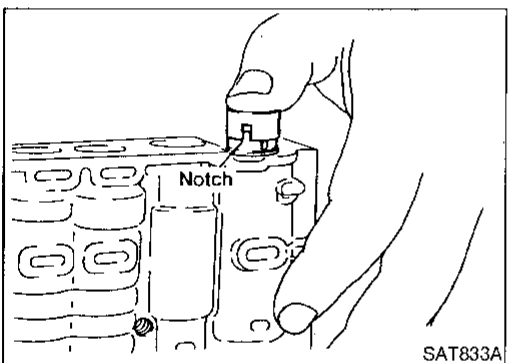

Accumulator control plug

- Align protrusion of accumulator control sleeve with notch in plug.
- Align parallel pin groove in plug with parallel pin, and install accumulator control valve.

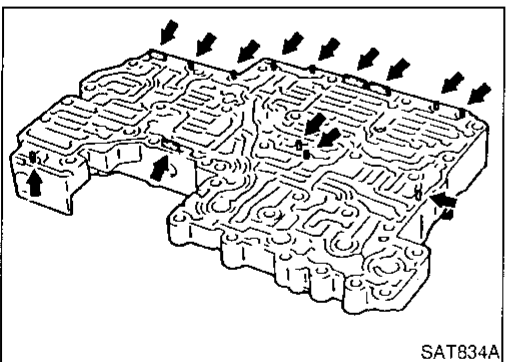

2. Install parallel pins and retainer plates.

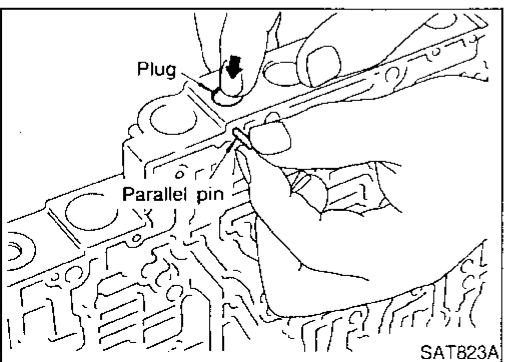

- While pushing plug, install parallel pin.

REPAIR FOR COMPONENT PARTS

Control Valve Upper Body (Cont'd)

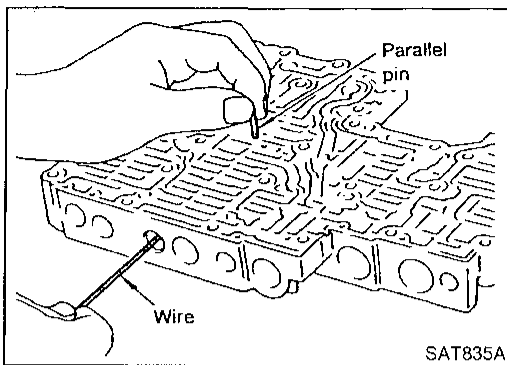

4-2 sequence valve and relay valve

- Push 4-2 sequence valve and relay valve with wire wrapped in vinyl tape to prevent scratching valve body. Install parallel pins.

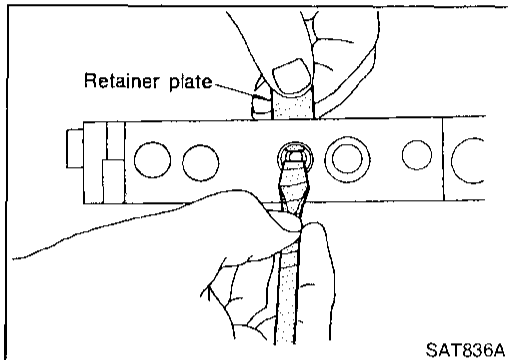

- Insert retainer plate while pushing spring.

GI

MA

EM

LC

EC

FE

CL

MT

AT

TF

PD

AX

SU

BR

ST

RS

BT

HA

SC

EL

IDX

COMPONENTS

Control Valve Lower Body

NAAT0124

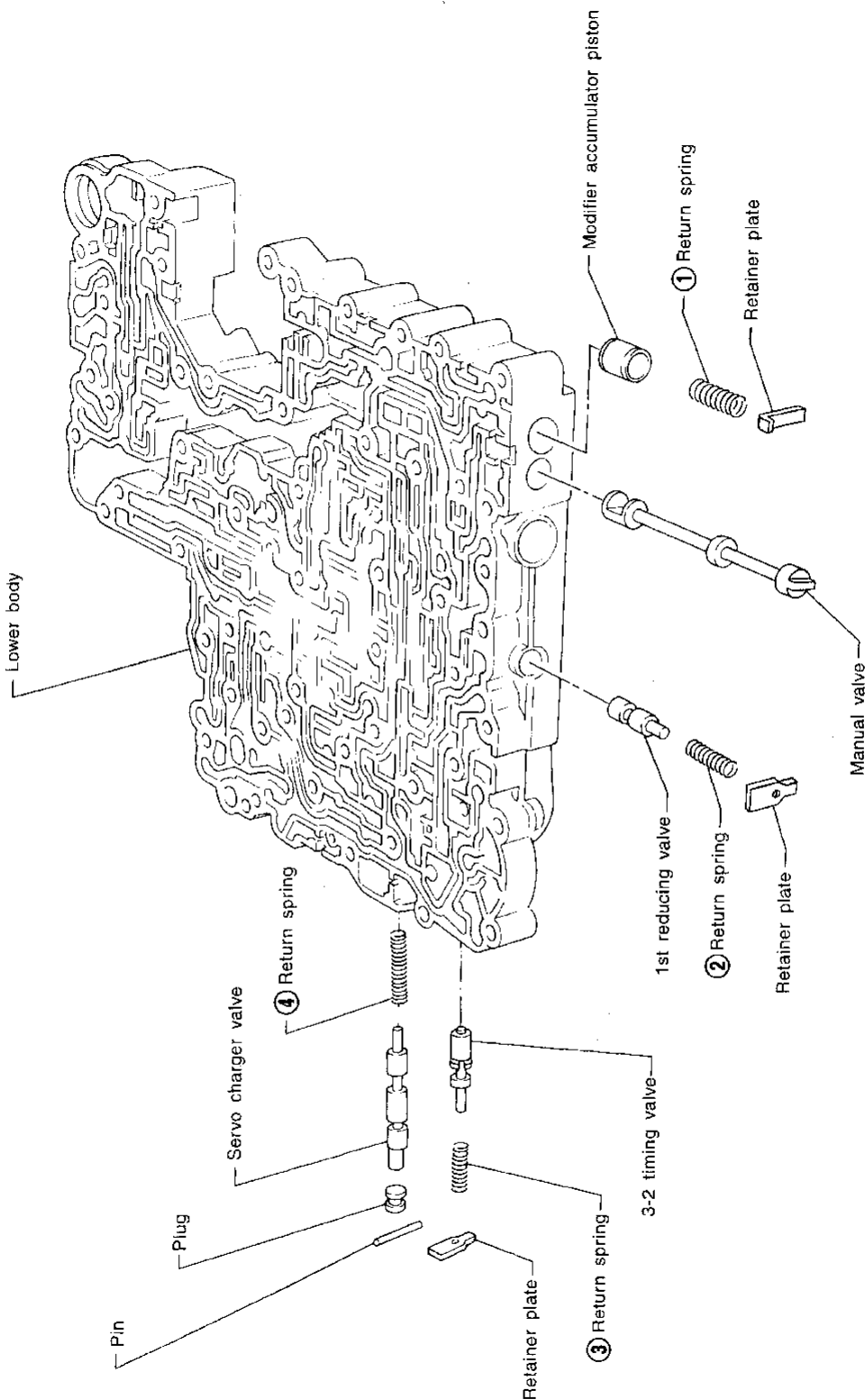

SEC. 317

SAT966I

Apply ATF to all components before their installation.
 Numbers preceding valve springs correspond with those shown in SDS on page AT-308.

REPAIR FOR COMPONENT PARTS

Control Valve Lower Body (Cont'd)

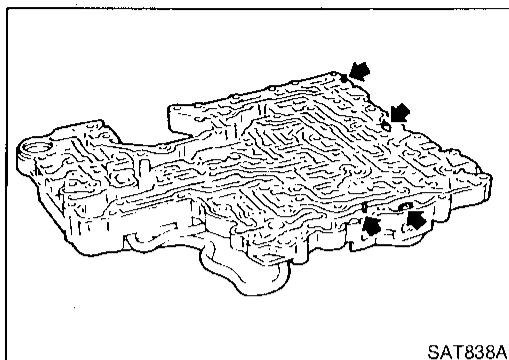

DISASSEMBLY

NAAT0125

1. Remove valves at parallel pins.
2. Remove valves at retainer plates.
For removal procedures, refer to "DISASSEMBLY" of Control Valve Upper Body.

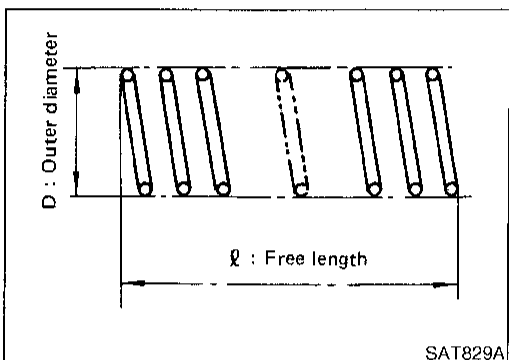

INSPECTION

NAAT0126

Valve Springs

NAAT0126S01

- Check each valve spring for damage or deformation. Also measure free length and outer diameter.

Inspection standard:

Refer to SDS, AT-308.

- Replace valve springs if deformed or fatigued.

Control Valves

NAAT0126S02

- Check sliding surfaces of control valves, sleeves and plugs for damage.

ASSEMBLY

NAAT0127

- Install control valves.
For installation procedures, refer to "ASSEMBLY" of Control Valve Upper Body, AT-258.

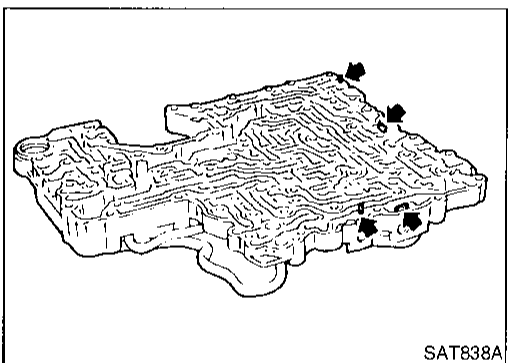

Reverse Clutch COMPONENTS

NAAT012#

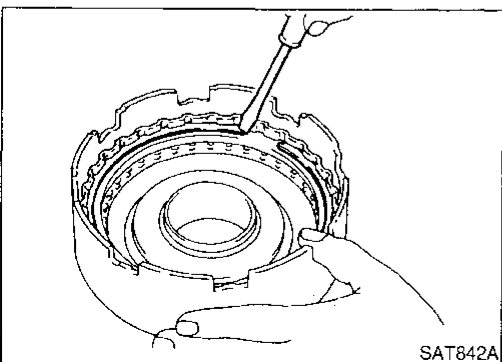
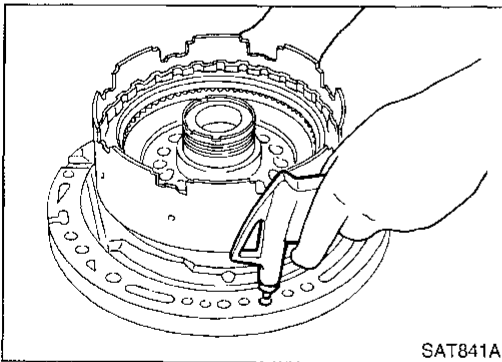
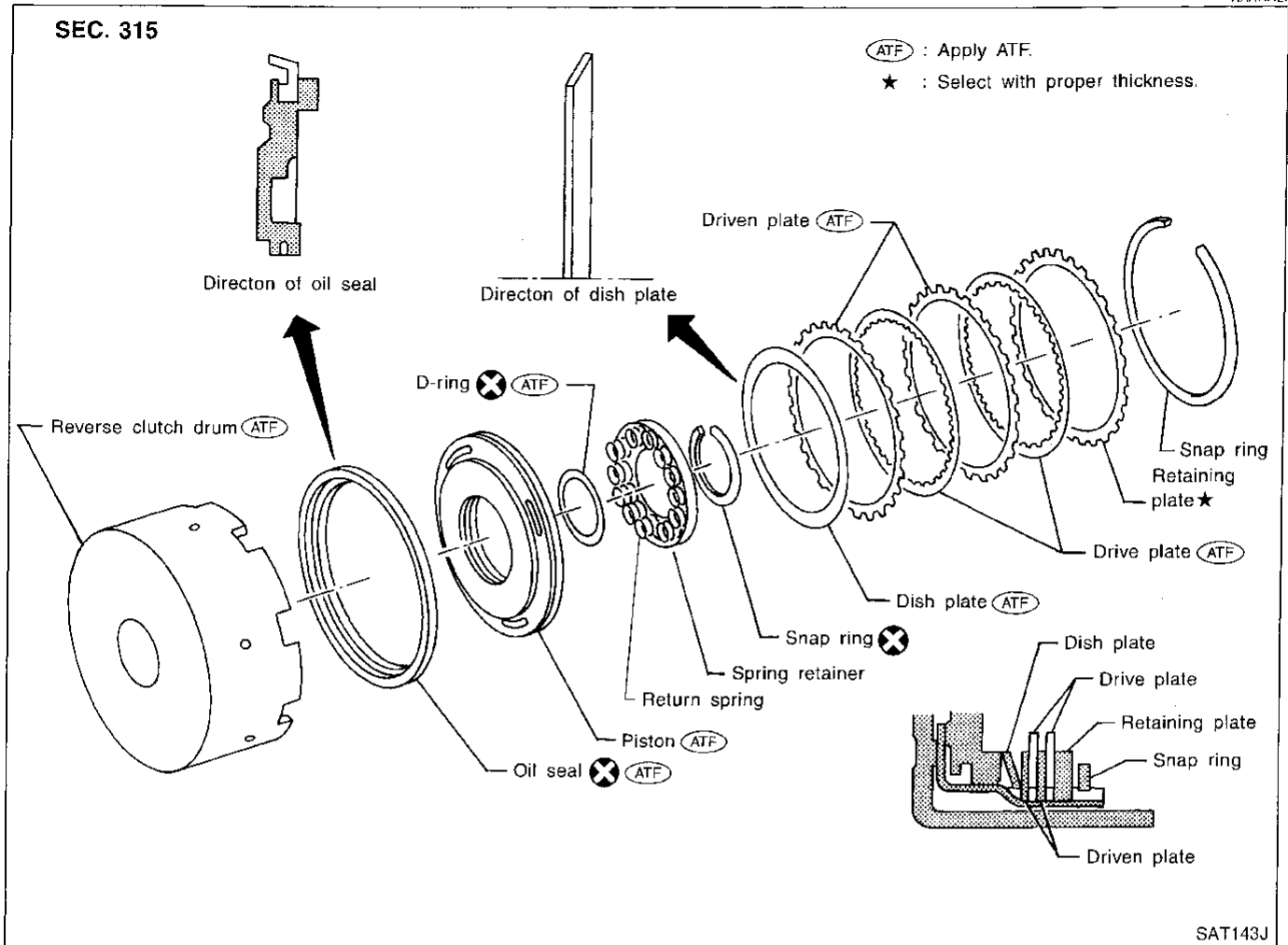

DISASSEMBLY

NAAT012#

1. Check operation of reverse clutch.
 - a. Install seal ring onto oil pump cover and install reverse clutch. Apply compressed air to oil hole.
 - b. Check to see that retaining plate moves to snap ring.
 - c. If retaining plate does not contact snap ring,
 - D-ring might be damaged.
 - Oil seal might be damaged.
 - Fluid might be leaking past piston check ball.
2. Remove drive plates, driven plates, retaining plate, dish plate and snap ring.

REPAIR FOR COMPONENT PARTS

Reverse Clutch (Cont'd)

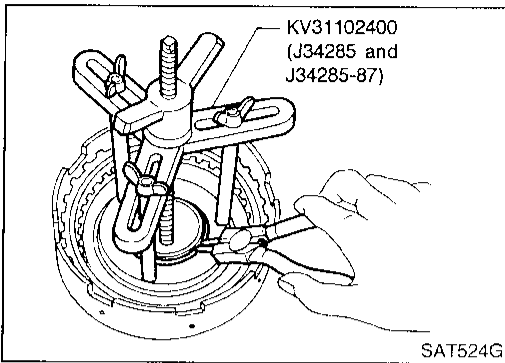

3. Remove snap ring from clutch drum while compressing clutch springs.
 - **Do not expand snap ring excessively.**
4. Remove spring retainer and return spring.

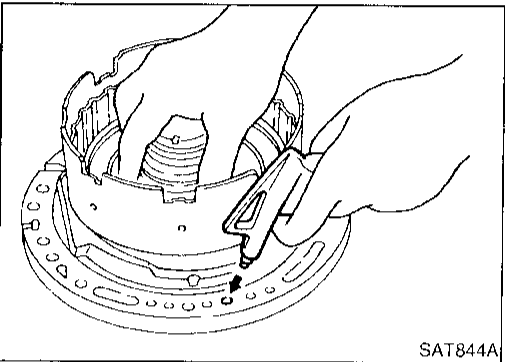

5. Install seal ring onto oil pump cover and install reverse clutch drum. While holding piston, gradually apply compressed air to oil hole until piston is removed.
 - **Do not apply compressed air abruptly.**
6. Remove D-ring and oil seal from piston.

INSPECTION

Reverse Clutch Snap Ring and Spring Retainer

- Check for deformation, fatigue or damage.

NAA10130
NAA10130S01

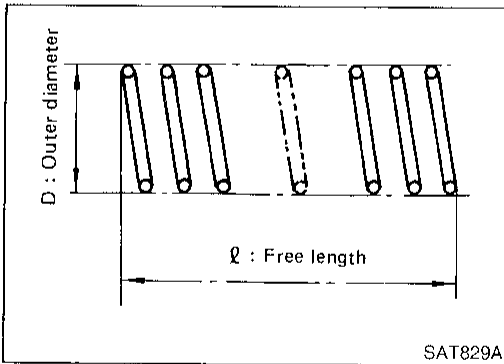

Reverse Clutch Return Springs

- Check for deformation or damage. Also measure free length and outside diameter.

Inspection standard:

Refer to SDS, AT-308.

NAA10130S02

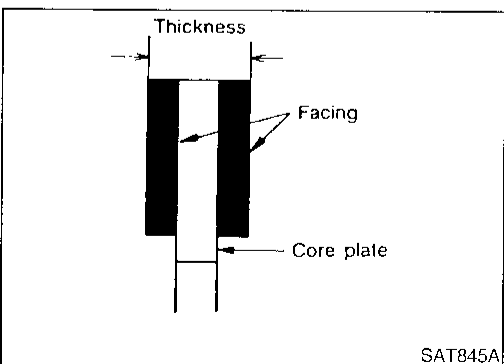

Reverse Clutch Drive Plates

- Check facing for burns, cracks or damage.
- Measure thickness of facing.

Thickness of drive plate:

Standard value: 1.90 - 2.05 mm (0.0748 - 0.0807 in)

Wear limit: 1.80 mm (0.0709 in)

- If not within wear limit, replace.

Reverse Clutch Dish Plate

- Check for deformation or damage.

NAA10130S03

NAA10130S04

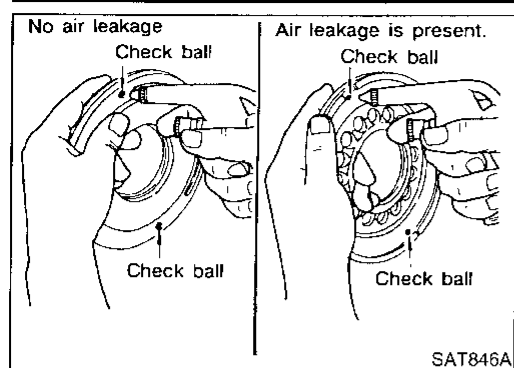

Reverse Clutch Piston

NAAT0130S05

- Shake piston to assure that balls are not seized.
- Apply compressed air to check ball oil hole opposite the return spring. Make sure there is no air leakage.
- Also apply compressed air to oil hole on return spring side to assure that air leaks past ball.

GI
MA
EM
LC

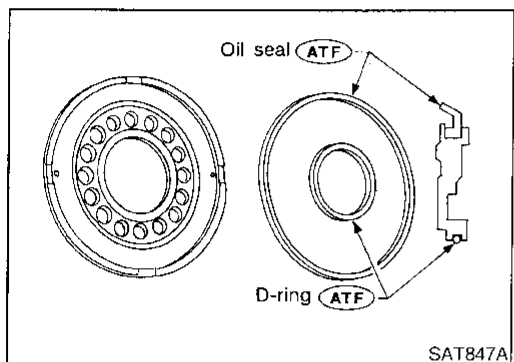

ASSEMBLY

NAAT0131

1. Install D-ring and oil seal on piston.
- **Apply ATF to both parts.**

EC
FE
CL
MT

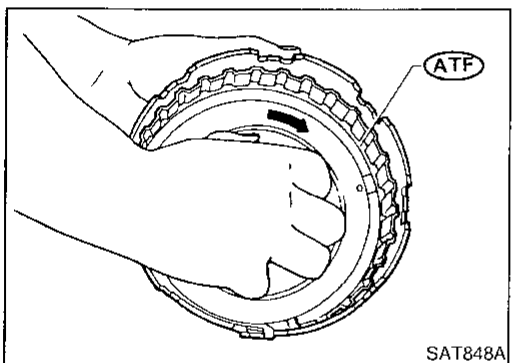

2. Install piston assembly by turning it slowly and evenly.
- **Apply ATF to inner surface of drum.**

AT

TF

PD

AX

SU

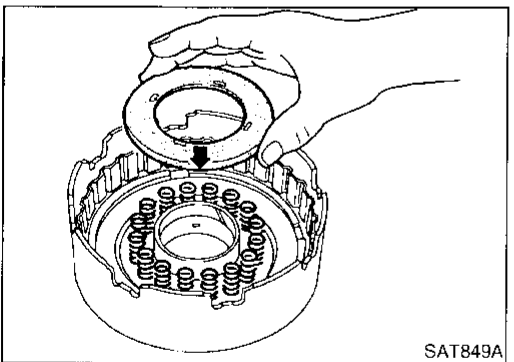

3. Install return springs and spring retainer.

BR

ST

RS

BT

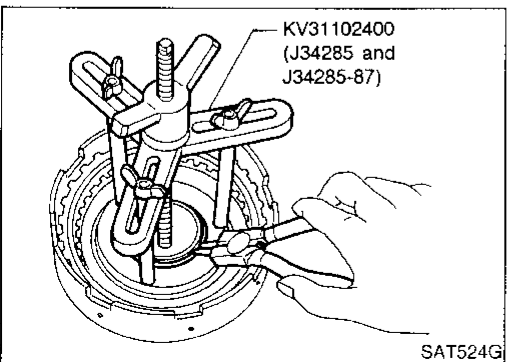

4. Install snap ring while compressing clutch springs.

HA

SC

EL

IDX

REPAIR FOR COMPONENT PARTS

Reverse Clutch (Cont'd)

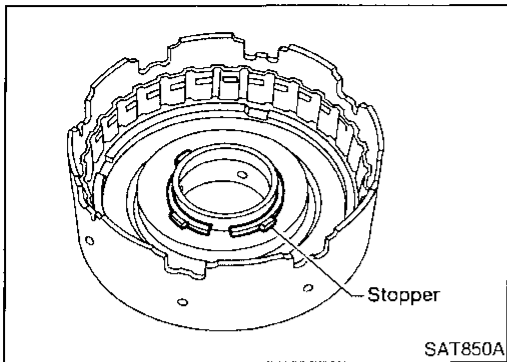

- Do not align snap ring gap with spring retainer stopper.

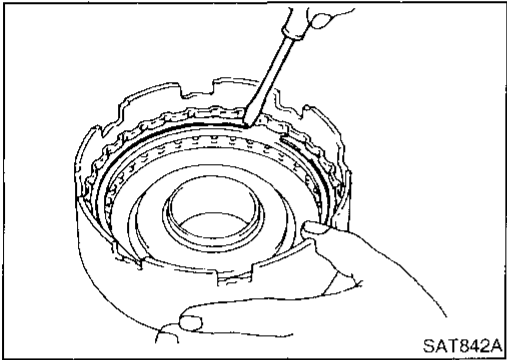

5. Install drive plates, driven plates, retaining plate and dish plate.
6. Install snap ring.

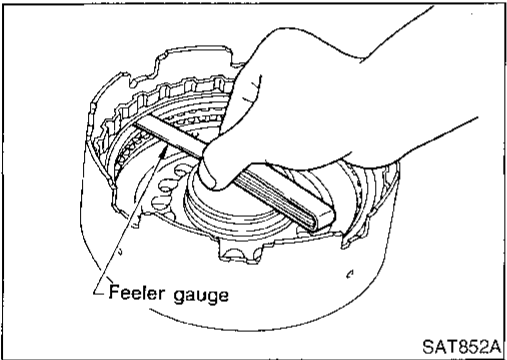

7. Measure clearance between retaining plate and snap ring. If not within allowable limit, select proper retaining plate.

Specified clearance:

Standard

0.5 - 0.8 mm (0.020 - 0.031 in)

Allowable limit

1.2 mm (0.047 in)

Retaining plate:

Refer to SDS, AT-309.

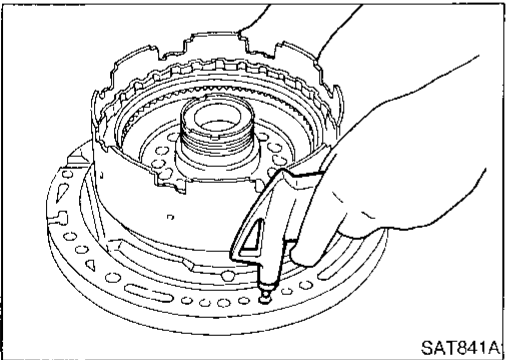

8. Check operation of reverse clutch.
Refer to "DISASSEMBLY" of Reverse Clutch, AT-263.

High Clutch
COMPONENTS

NAAT0132

SEC. 315

For the number of clutch sheets (drive plate and driven plate), refer to the below cross-section.

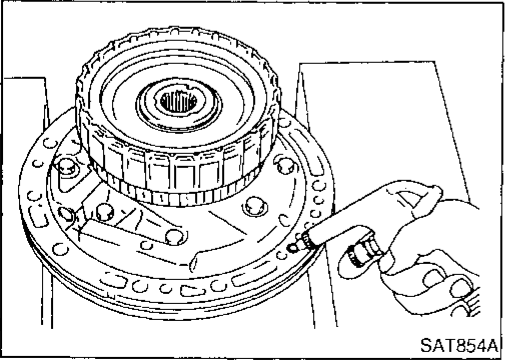
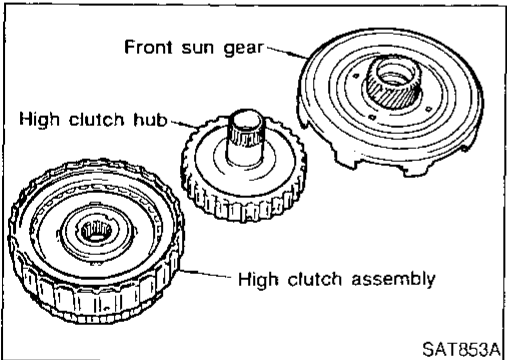
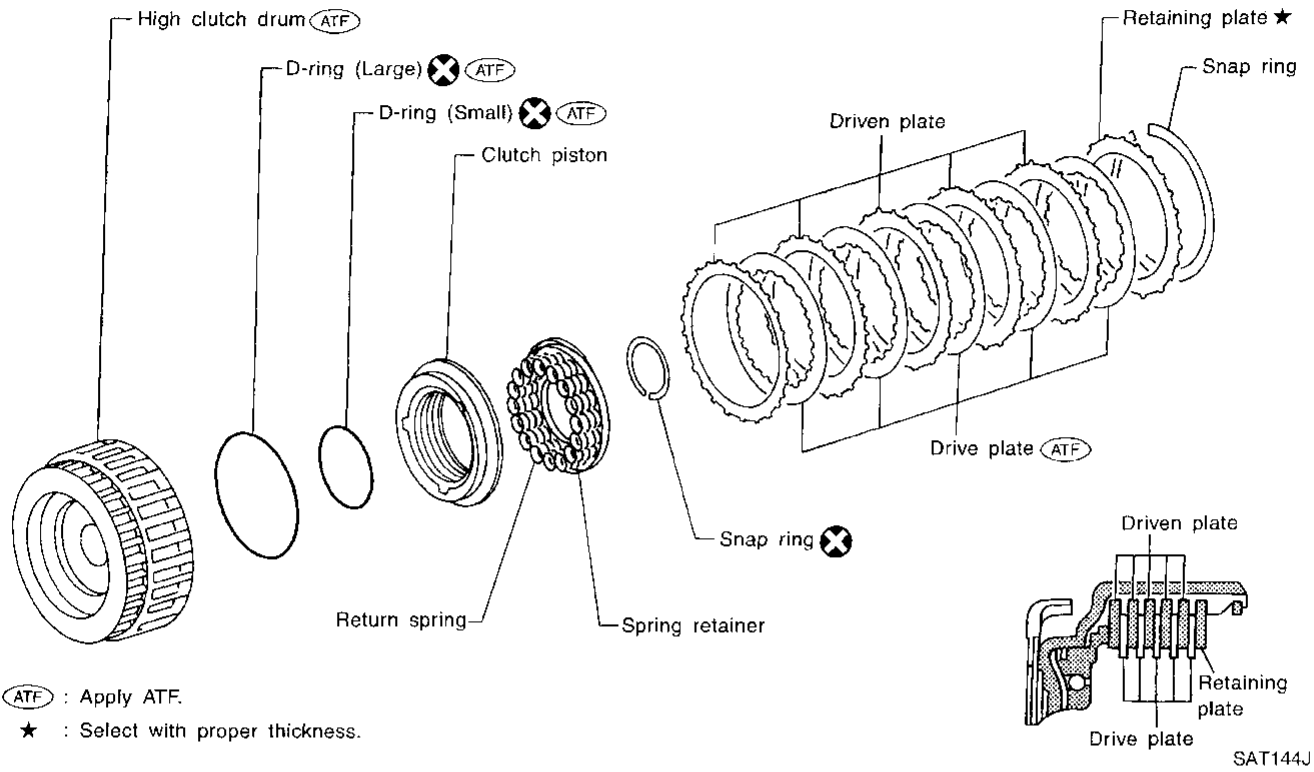

DISASSEMBLY AND ASSEMBLY

NAAT0133

Service procedures for high clutch are essentially the same as those for reverse clutch, with the following exception:

- Check of high clutch operation

CI
 MA
 EM
 LC
 EC
 FE
 CL
 MT
 AT
 TF
 PD
 AX
 SU
 BR
 ST
 RS
 BT
 HA
 SC
 EL
 IDX

REPAIR FOR COMPONENT PARTS

High Clutch (Cont'd)

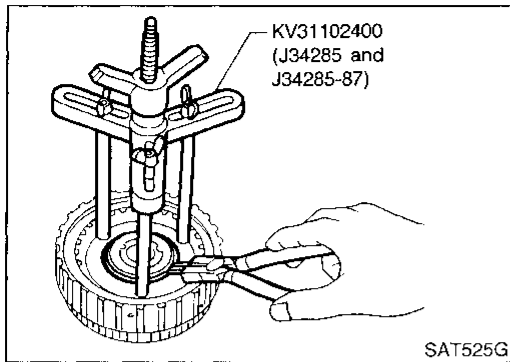

- Removal and installation of return spring

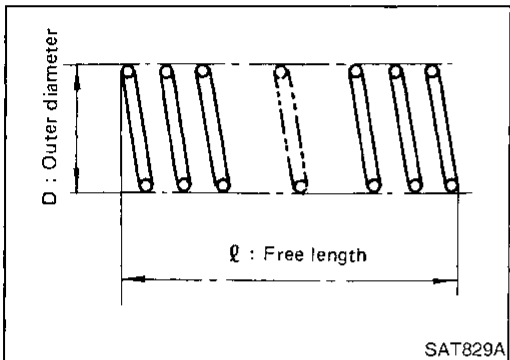

- Inspection of high clutch return springs
Inspection standard:
Refer to SDS, AT-308.

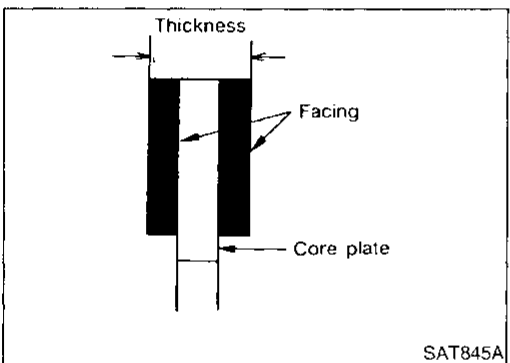

- Inspection of high clutch drive plate
Thickness of drive plate:
Standard
1.52 - 1.67 mm (0.0598 - 0.0657 in)
Wear limit
1.40 mm (0.0551 in)

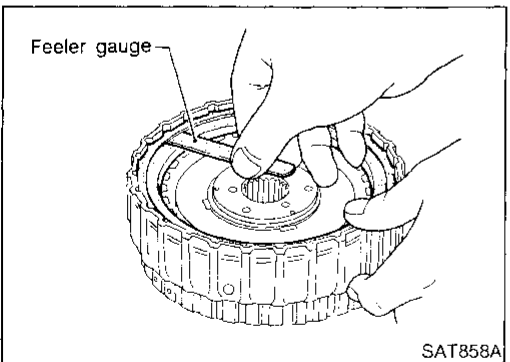

- Measurement of clearance between retaining plate and snap ring
Specified clearance:
Standard
1.8 - 2.2 mm (0.071 - 0.087 in)
Allowable limit
2.8 mm (0.110 in)
Retaining plate:
Refer to SDS, AT-309.

Forward and Overrun Clutches COMPONENTS

NAAT0134

SEC. 315

For the number of clutch sheets (drive plate and driven plate), refer to the below cross-section.

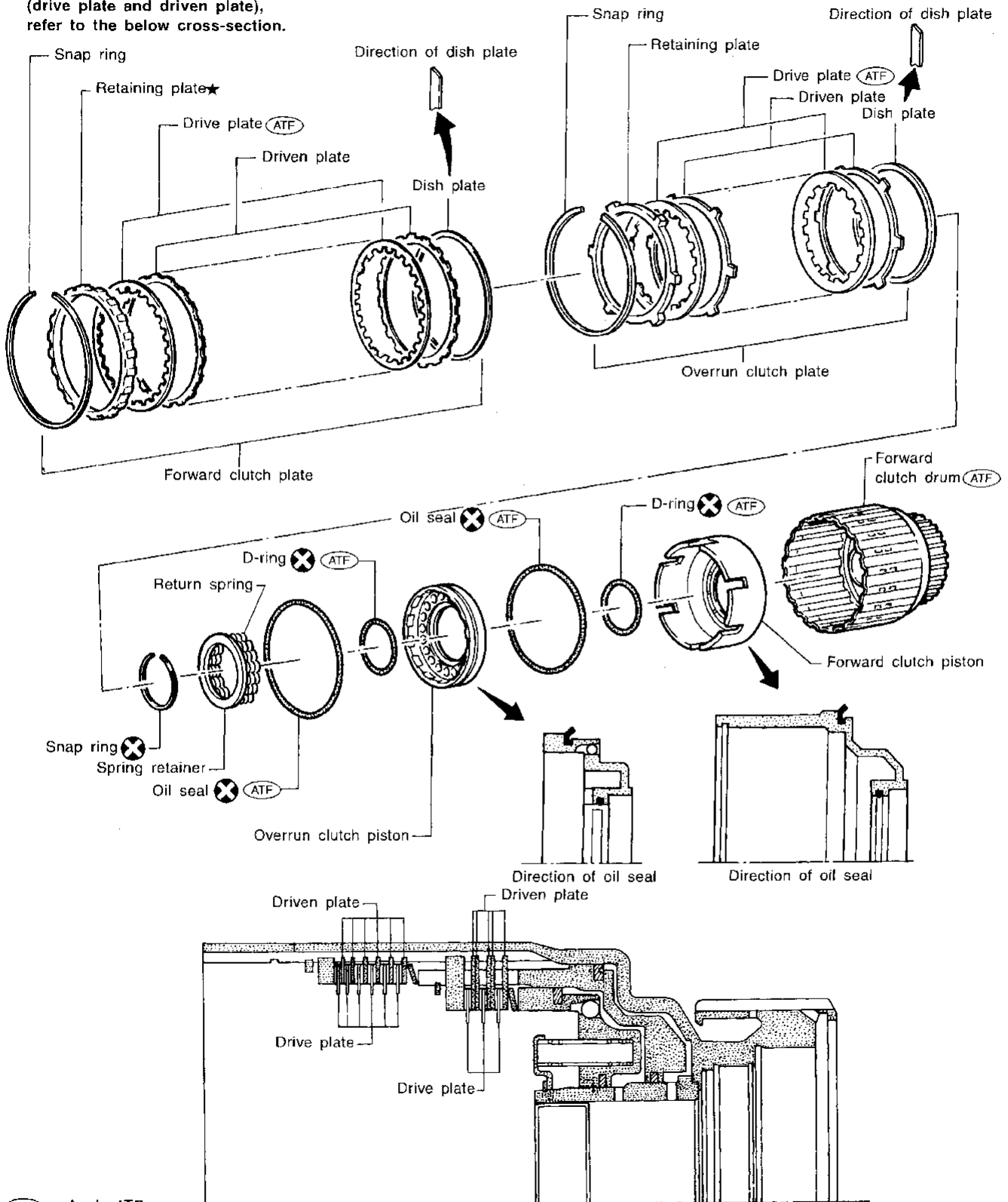

(ATF) : Apply ATF.

★ : Select with proper thickness.

SAT145J

GI
MA
EM
LC
EC
FE
CL
MT
AT
TF
PD
AX
SU
BR
ST
RS
BT
HA
SC
EL
DX

REPAIR FOR COMPONENT PARTS

Forward and Overrun Clutches (Cont'd)

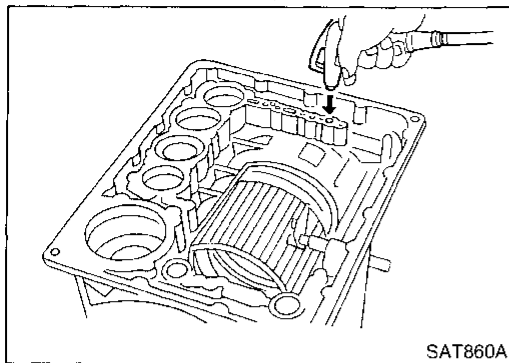

DISASSEMBLY AND ASSEMBLY

NAAT0135

Forward and overrun clutches are serviced essentially the same way as reverse clutch is serviced. However, note the following exceptions.

- Check of forward clutch operation

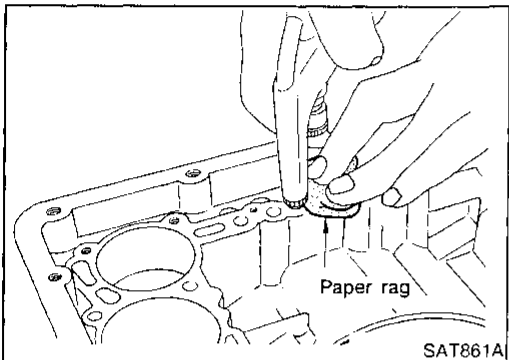

- Check of overrun clutch operation

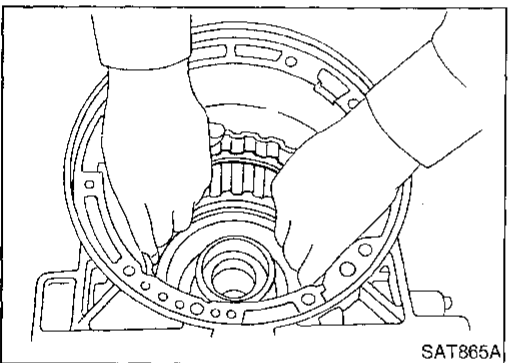

- Removal of forward clutch drum
Remove forward clutch drum from transmission case by holding snap ring.

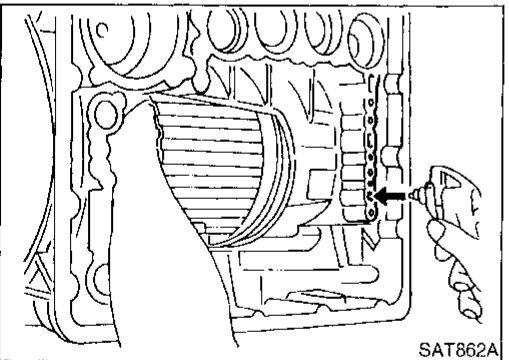

- Removal of forward and overrun clutch pistons
a) While holding overrun clutch piston, gradually apply compressed air to oil hole.

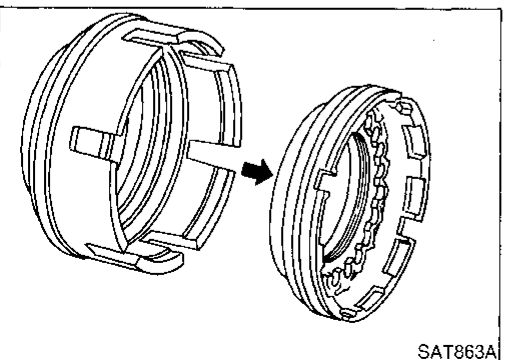

- b) Remove overrun clutch from forward clutch.

REPAIR FOR COMPONENT PARTS

Forward and Overrun Clutches (Cont'd)

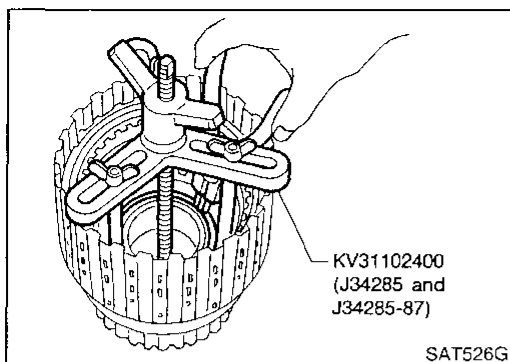

- Removal and installation of return springs

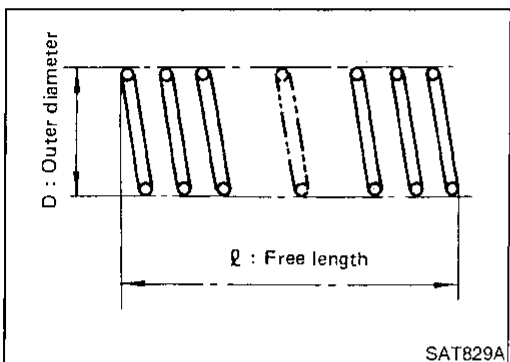

- Inspection of forward clutch and overrun clutch return springs
Inspection standard:
Refer to SDS, AT-308.

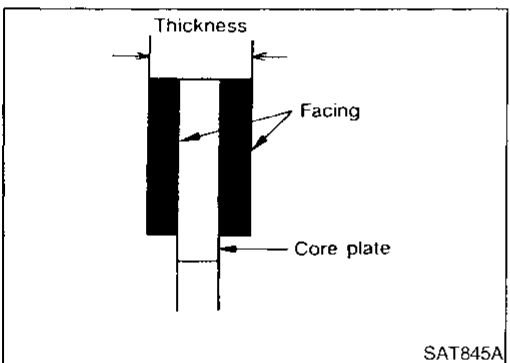

- Inspection of forward clutch drive plates
Thickness of drive plate:
Standard
1.52 - 1.67 mm (0.0598 - 0.0657 in)
Wear limit
1.40 mm (0.0551 in)

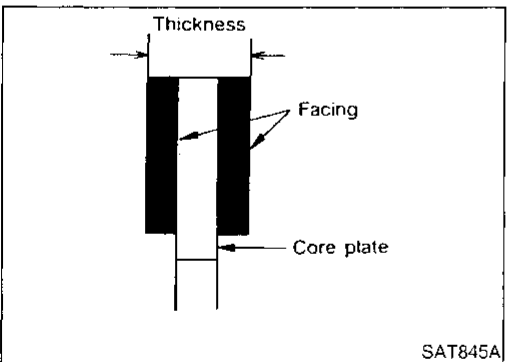

- Inspection of overrun clutch drive plates
Thickness of drive plate:
Standard
1.90 - 2.05 mm (0.0748 - 0.0807 in)
Wear limit
1.80 mm (0.0709 in)

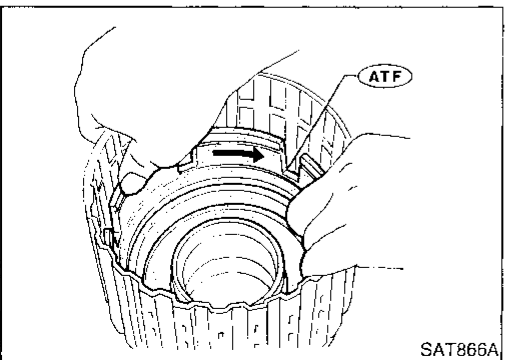

- Installation of forward clutch piston and overrun clutch piston
a) Install forward clutch piston by turning it slowly and evenly.
● **Apply ATF to inner surface of clutch drum.**

GI

MA

EM

LC

EC

FE

CL

MT

AT

TF

PD

AX

SU

BR

ST

RS

BT

HA

SC

EL

iDX

REPAIR FOR COMPONENT PARTS

Forward and Overrun Clutches (Cont'd)

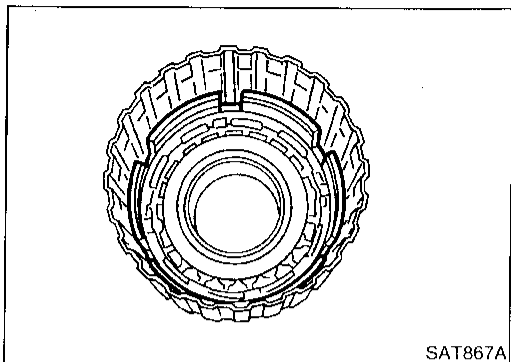

- Align notch in forward clutch piston with groove in forward clutch drum.

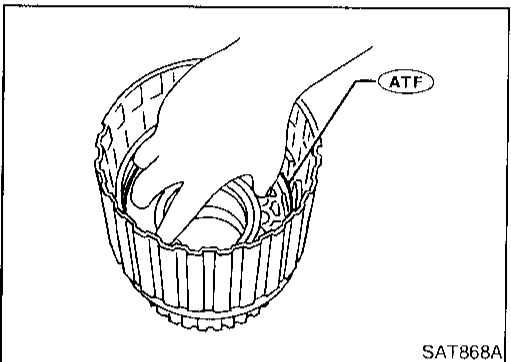

- b) Install overrun clutch by turning it slowly and evenly.
- Apply ATF to inner surface of forward clutch piston.

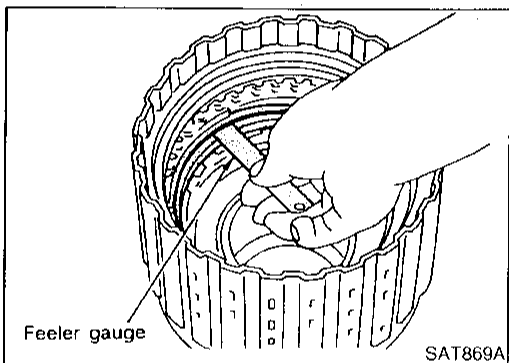

- Measurement of clearance between retaining plate and snap ring of overrun clutch

Specified clearance:

Standard

1.0 - 1.4 mm (0.039 - 0.055 in)

Allowable limit

2.0 mm (0.079 in)

Retaining plate:

Refer to SDS, AT-310.

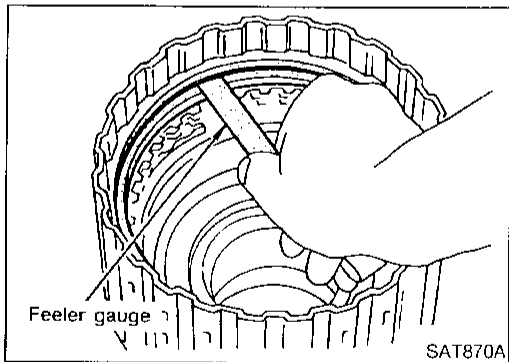

- Measurement of clearance between retaining plate and snap ring of forward clutch

Specified clearance:

Standard

0.35 - 0.75 mm (0.0138 - 0.0295 in)

Allowable limit

1.85 mm (0.0728 in)

Retaining plate:

Refer to SDS, AT-310.

Low & Reverse Brake COMPONENTS

NAAT0136

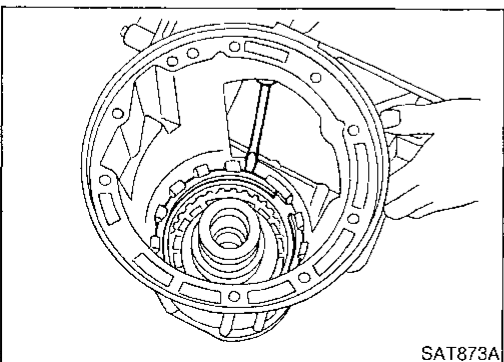
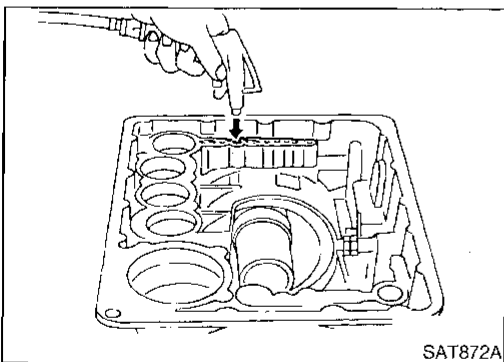
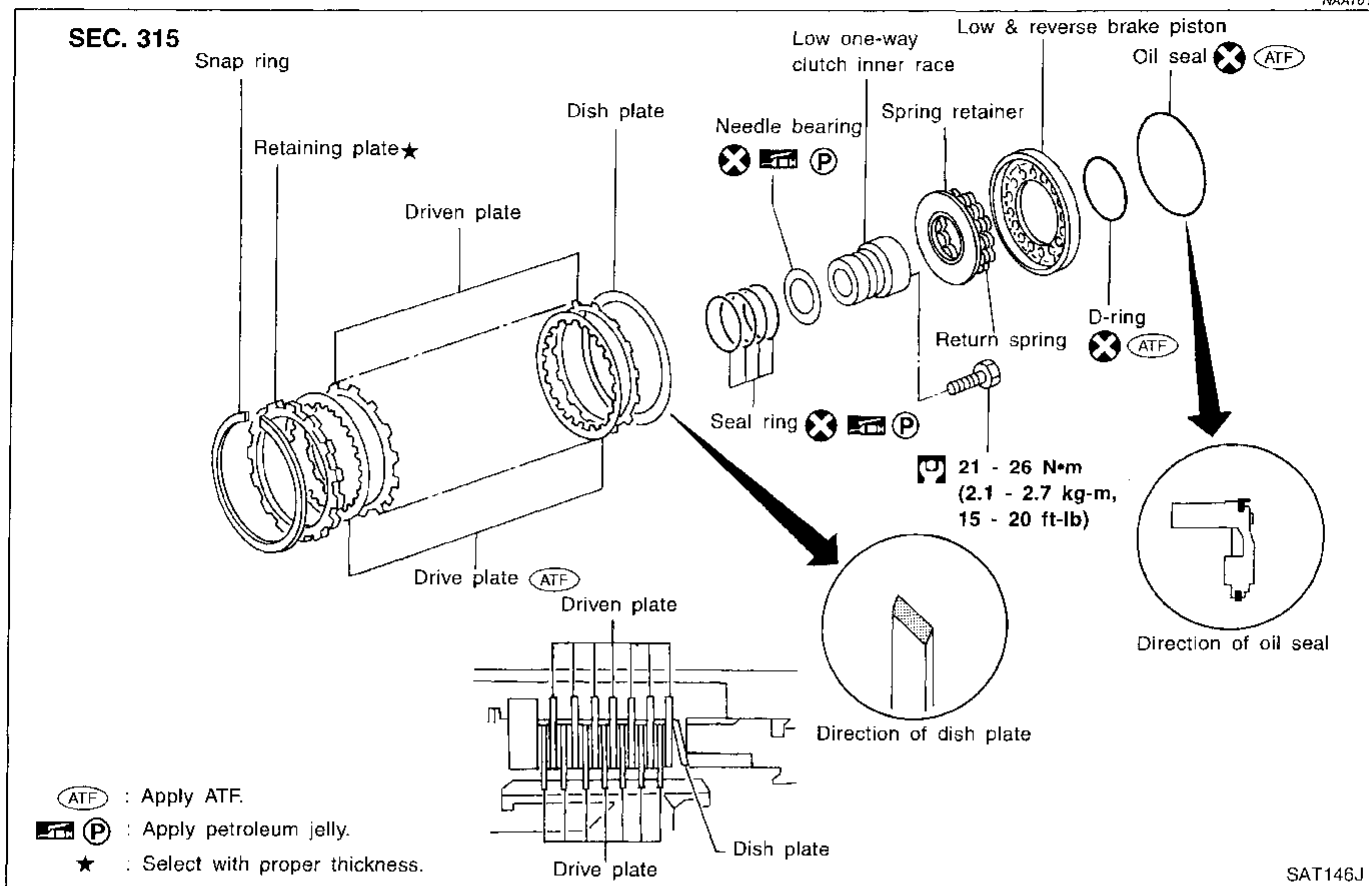

DISASSEMBLY

NAAT0137

- Check operation of low and reverse brake.
 - Install seal ring onto oil pump cover and install reverse clutch. Apply compressed air to oil hole.
 - Check to see that retaining plate moves to snap ring.
 - If retaining plate does not contact snap ring,
 - D-ring might be damaged.
 - Oil seal might be damaged.
 - Fluid might be leaking past piston check ball.
- Remove snap ring, low and reverse brake drive plates, driven plates and dish plate.

REPAIR FOR COMPONENT PARTS

Low & Reverse Brake (Cont'd)

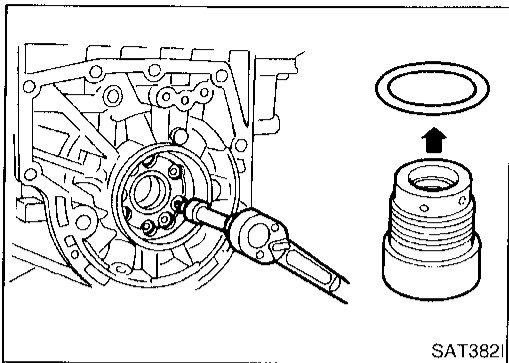

3. Remove low one-way clutch inner race, spring retainer and return spring from transmission case.
4. Remove seal rings from low one-way clutch inner race.
5. Remove needle bearing from low one-way clutch inner race.

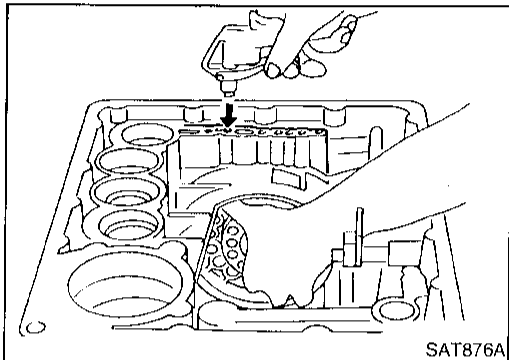

6. Remove low and reverse brake piston using compressed air.
7. Remove oil seal and D-ring from piston.

INSPECTION

Low and Reverse Brake Snap Ring and Spring Retainer

NAAT0138
NAAT0138S01

- Check for deformation, or damage.

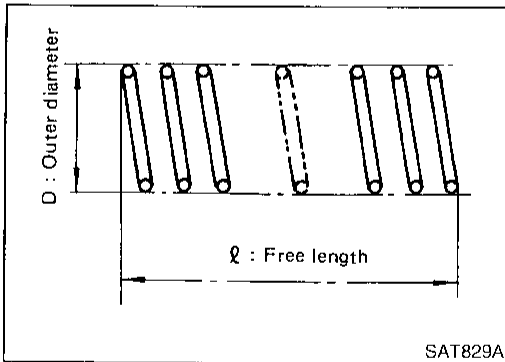

Low and Reverse Brake Return Springs

NAAT0138S02

- Check for deformation or damage. Also measure free length and outside diameter.

Inspection standard:

Refer to SDS, AT-308.

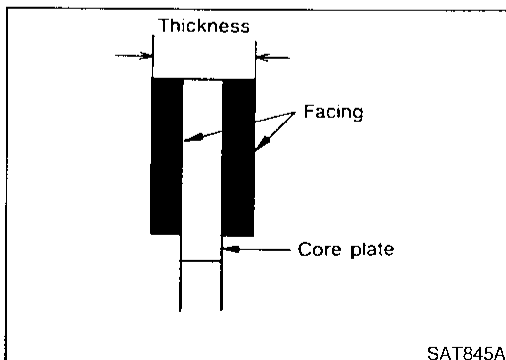

Low and Reverse Brake Drive Plates

NAAT0138S03

- Check facing for burns, cracks or damage.
- Measure thickness of facing.

Thickness of drive plate:

Standard value

1.52 - 1.67 mm (0.0598 - 0.0657 in)

Wear limit

1.40 mm (0.0551 in)

- If not within wear limit, replace.

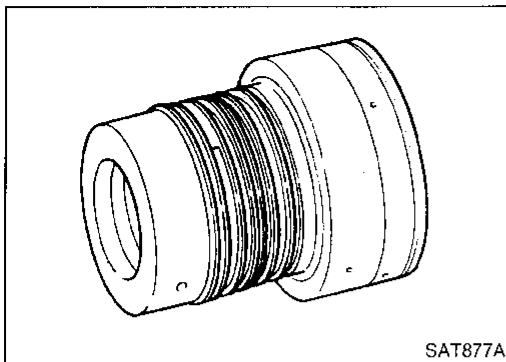

Low One-way Clutch Inner Race

NAAT0138S04

- Check frictional surface of inner race for wear or damage.

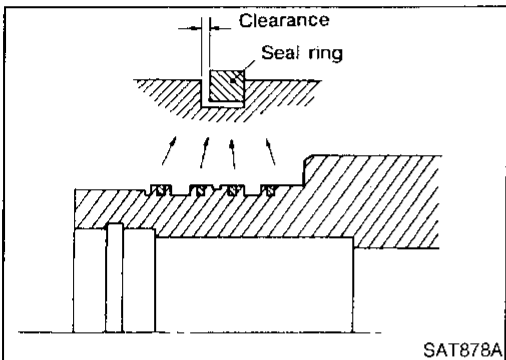

- Install a new seal rings onto low one-way clutch inner race.
- **Be careful not to expand seal ring gap excessively.**
- Measure seal ring-to-groove clearance.

Inspection standard:

Standard value: 0.10 - 0.25 mm (0.0039 - 0.0098 in)

Allowable limit: 0.25 mm (0.0098 in)

- If not within allowable limit, replace low one-way clutch inner race.

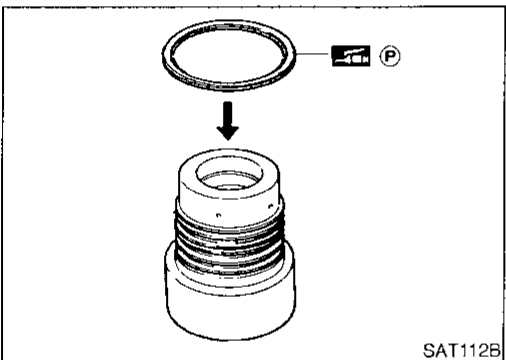

ASSEMBLY

NAAT0139

1. Install needle bearing onto one-way clutch inner race.
 - Pay attention to its direction — **Black surface goes to rear side.**
 - Apply petroleum jelly to needle bearing.

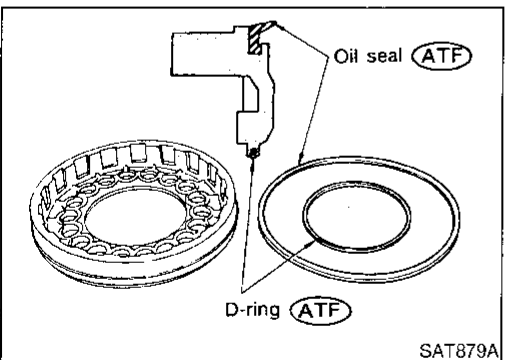

2. Install oil seal and D-ring onto piston.
 - **Apply ATF to oil seal and D-ring.**

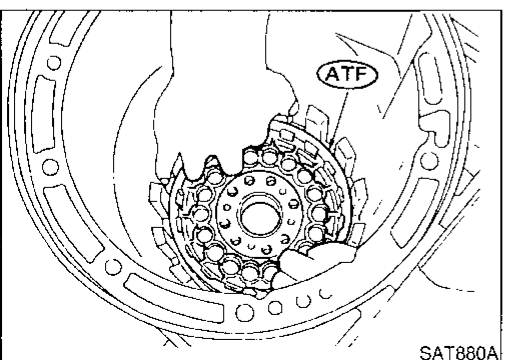

3. Install piston by rotating it slowly and evenly.
 - **Apply ATF to inner surface of transmission case.**

GI

MA

EM

LC

EC

FE

CL

MT

AT

TF

PD

AX

SU

BR

ST

RS

BT

HA

SC

EL

IDX

REPAIR FOR COMPONENT PARTS

Low & Reverse Brake (Cont'd)

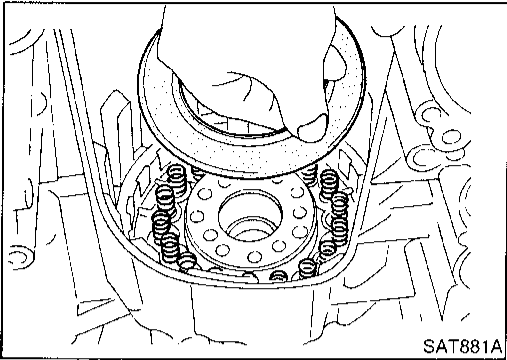

4. Install return springs, spring retainer and low one-way clutch inner race onto transmission case.
5. Install dish plate, low and reverse brake drive plates, driven plates and retaining plate.
6. Install snap ring on transmission case.

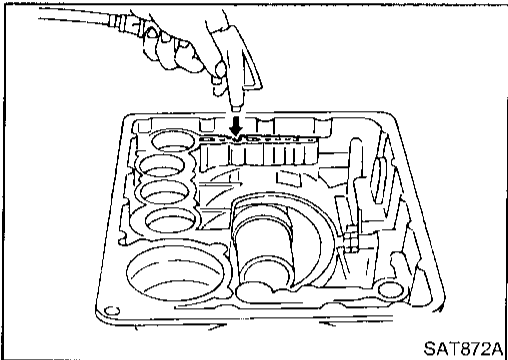

7. Check operation of low and reverse brake clutch piston. Refer to "DISASSEMBLY", AT-273.

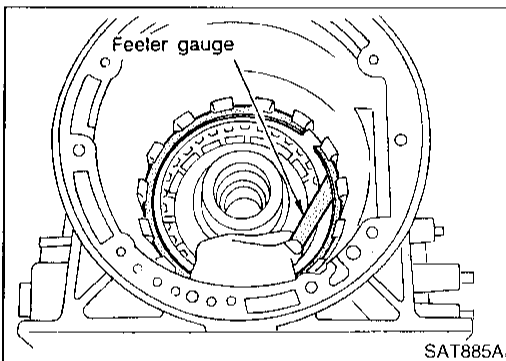

8. Measure clearance between retaining plate and snap ring. If not within allowable limit, select proper retaining plate.

Specified clearance:

Standard

0.8 - 1.1 mm (0.031 - 0.043 in)

Allowable limit

2.3 mm (0.091 in)

Retaining plate:

Refer to SDS, AT-311.

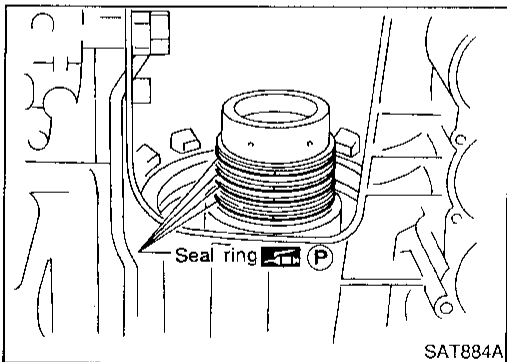

9. Install low one-way clutch inner race seal ring.
 - Apply petroleum jelly to seal ring.
 - Make sure seal rings are pressed firmly into place and held by petroleum jelly.

**Forward Clutch Drum Assembly
COMPONENTS**

NAAT0140

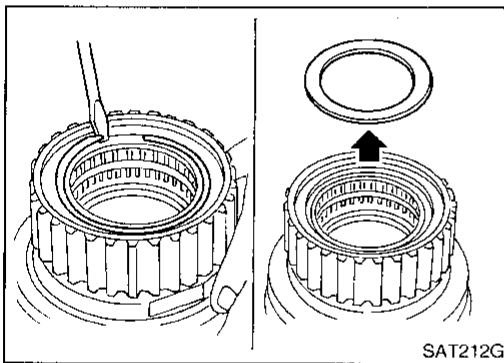
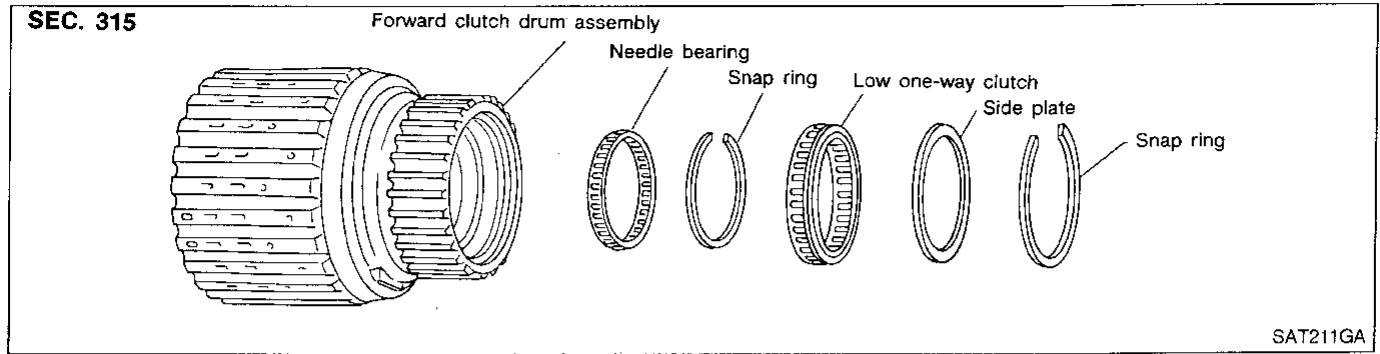

DISASSEMBLY

1. Remove snap ring from forward clutch drum.
2. Remove side plate from forward clutch drum.

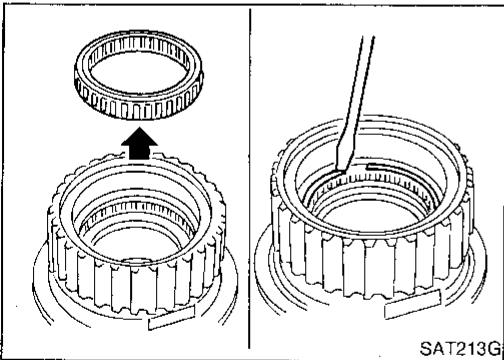

3. Remove low one-way clutch from forward clutch drum.
4. Remove snap ring from forward clutch drum.

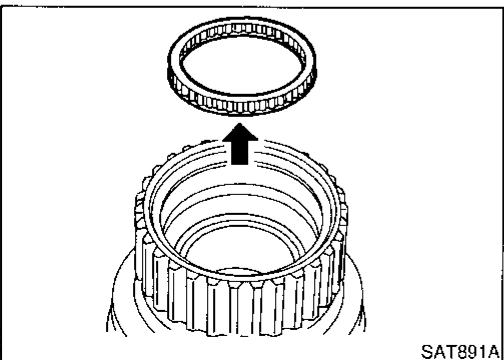

5. Remove needle bearing from forward clutch drum.

GI
MA
EM
LC
EC
FE
CL
MT
AT
TF
PD
AX
SU
BR
ST
RS
BT
HA
SC
EL
IDX

REPAIR FOR COMPONENT PARTS

Forward Clutch Drum Assembly (Cont'd)

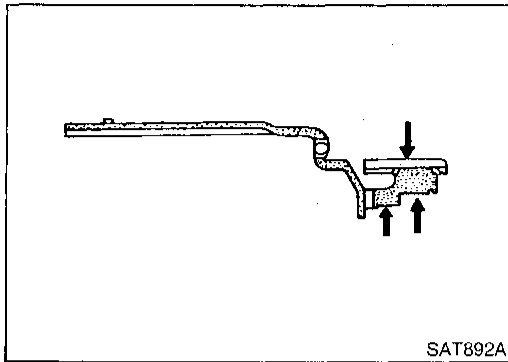

INSPECTION

Forward Clutch Drum

NAAT0142

NAAT0142S01

- Check spline portion for wear or damage.
- Check frictional surfaces of low one-way clutch and needle bearing for wear or damage.

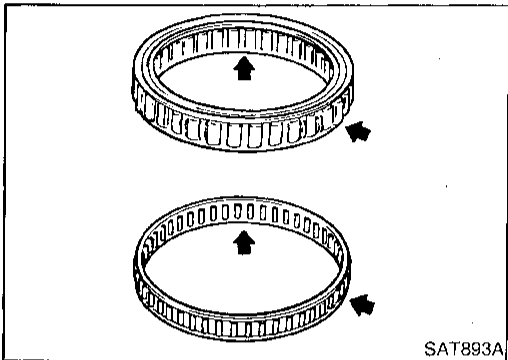

Needle Bearing and Low One-way Clutch

NAAT0142S02

- Check frictional surface for wear or damage.

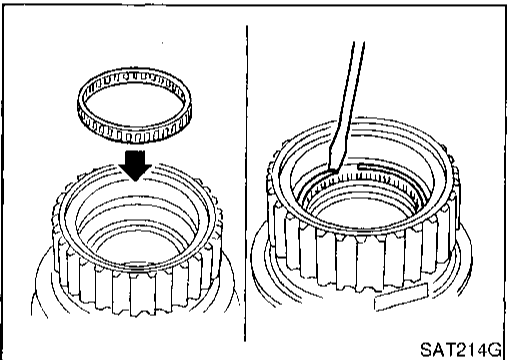

ASSEMBLY

NAAT0143

1. Install needle bearing in forward clutch drum.
2. Install snap ring onto forward clutch drum.

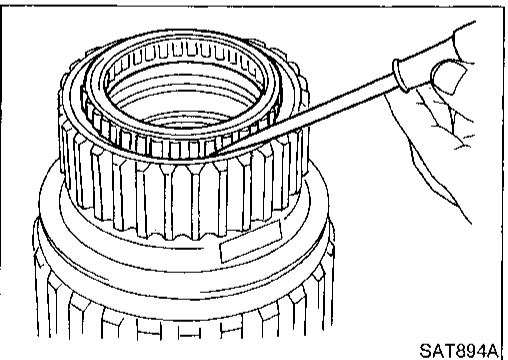

3. Install low one-way clutch onto forward clutch drum by pushing the roller in evenly.

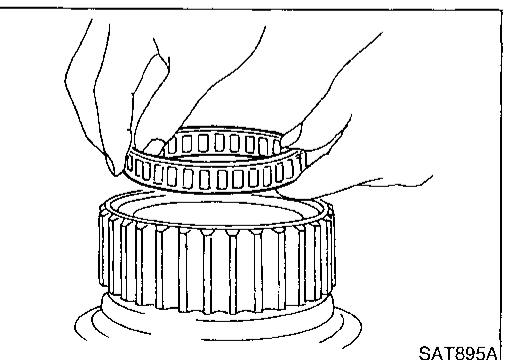

- Install low one-way clutch with flange facing rearward.

REPAIR FOR COMPONENT PARTS

Forward Clutch Drum Assembly (Cont'd)

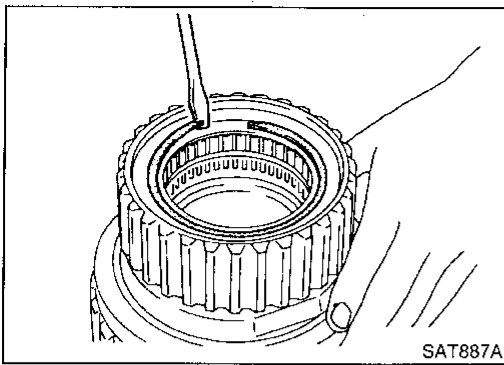

SAT887A

4. Install side plate onto forward clutch drum.
5. Install snap ring onto forward clutch drum.

Rear Internal Gear and Forward Clutch Hub COMPONENTS

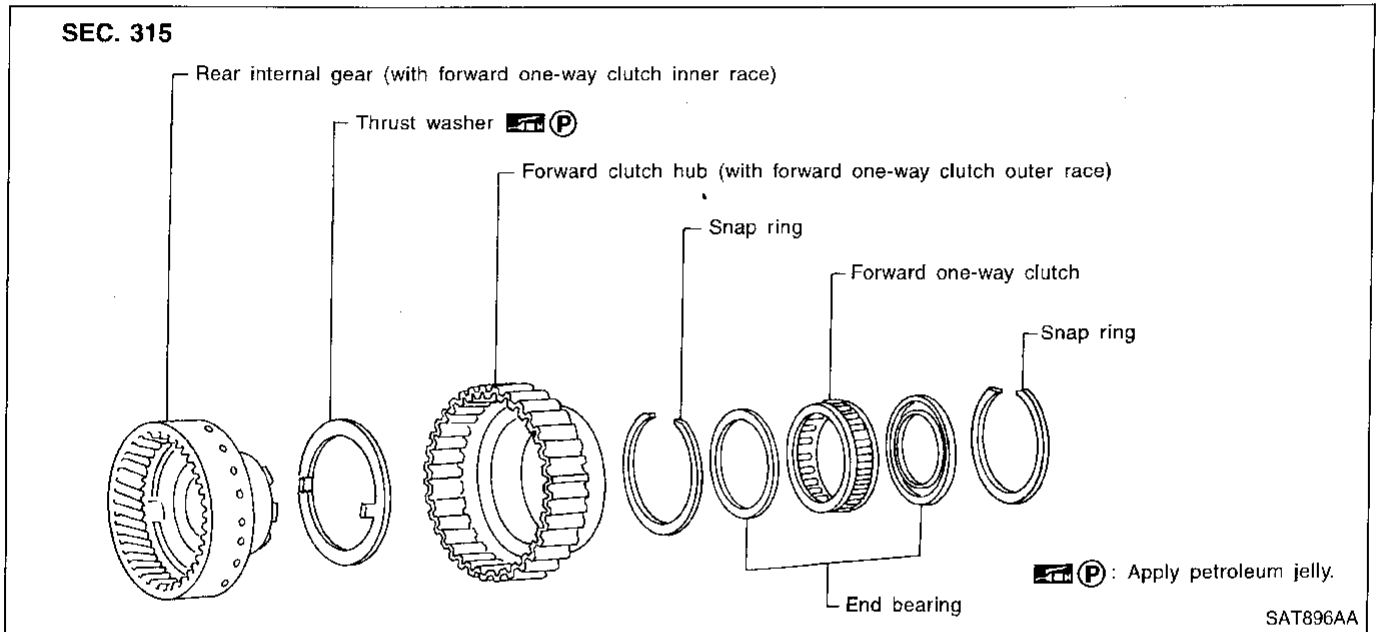

SEC. 315

Rear internal gear (with forward one-way clutch inner race)

Thrust washer (P)

Forward clutch hub (with forward one-way clutch outer race)

Snap ring

Forward one-way clutch

Snap ring

End bearing

(P) : Apply petroleum jelly.

SAT896AA

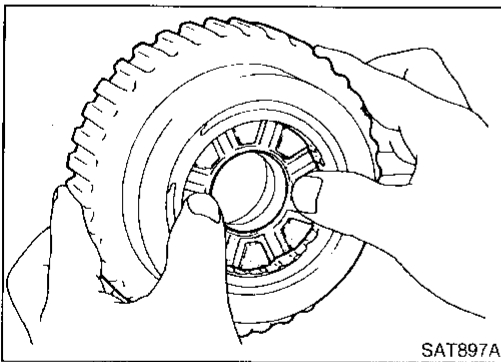

SAT897A

DISASSEMBLY

1. Remove rear internal gear by pushing forward clutch hub forward.

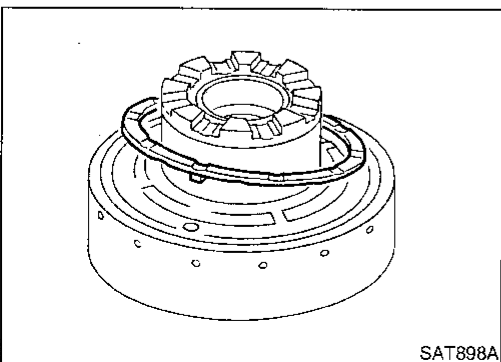

SAT898A

2. Remove thrust washer from rear internal gear.

GI
MA
EM
LC
EC
FE
CL
MT
AT
TF
PD
AX
SU
BR
ST
RS
BT
HA
SC
EL
IDX

REPAIR FOR COMPONENT PARTS

Rear Internal Gear and Forward Clutch Hub (Cont'd)

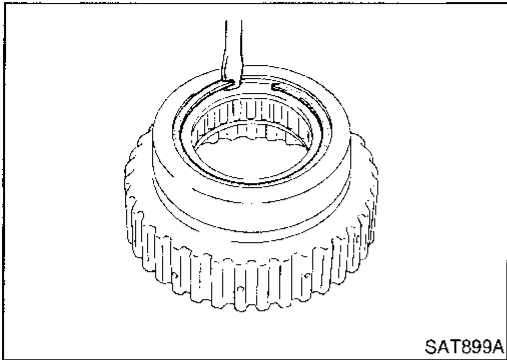

3. Remove snap ring from forward clutch hub.

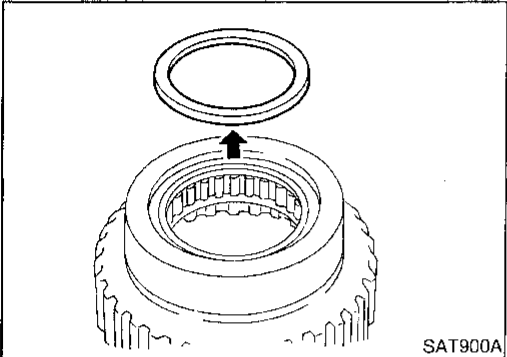

4. Remove end bearing.

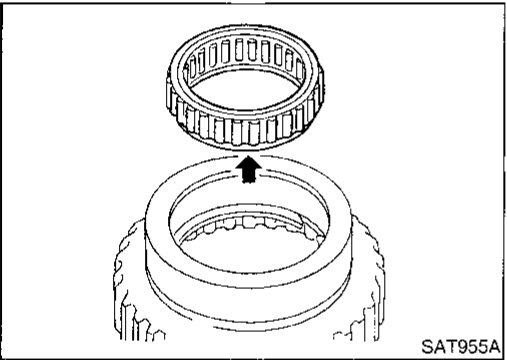

5. Remove forward one-way clutch and end bearing as a unit from forward clutch hub.

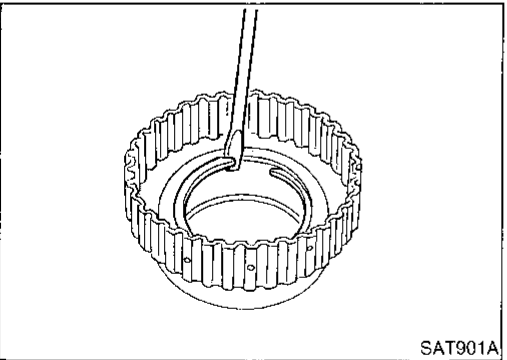

6. Remove snap ring from forward clutch hub.

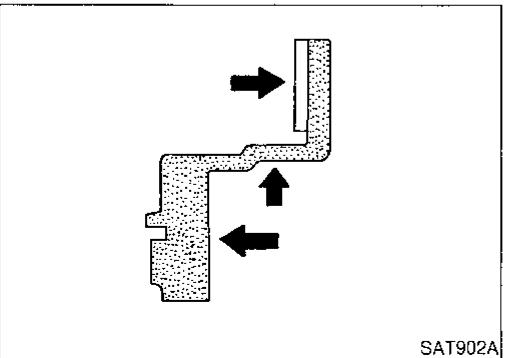

INSPECTION

Rear Internal Gear and Forward Clutch Hub

NAAT0146

NAAT0146S01

- Check gear for excessive wear, chips or cracks.
- Check frictional surfaces of forward one-way clutch and thrust washer for wear or damage.
- Check spline for wear or damage.

REPAIR FOR COMPONENT PARTS

Rear Internal Gear and Forward Clutch Hub (Cont'd)

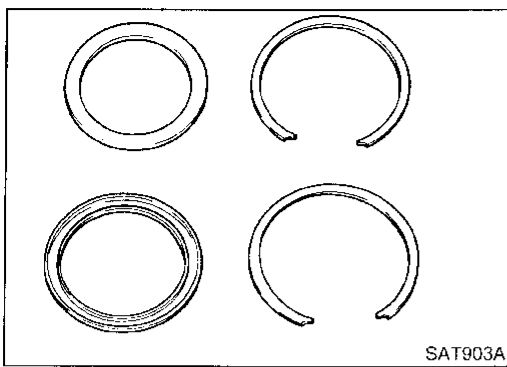

Snap Ring and End Bearing

NAAT0146S02

- Check for deformation or damage.

ASSEMBLY

NAAT0147

1. Install snap ring onto forward clutch hub.

GI

MA

EM

LC

EC

FE

CL

MT

AT

TF

PD

AX

SU

BR

ST

RS

BT

HA

SC

EL

IDX

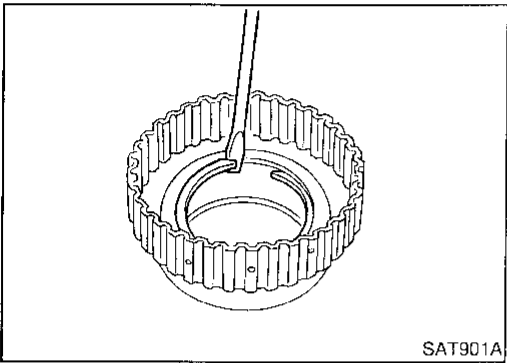

2. Install end bearing.

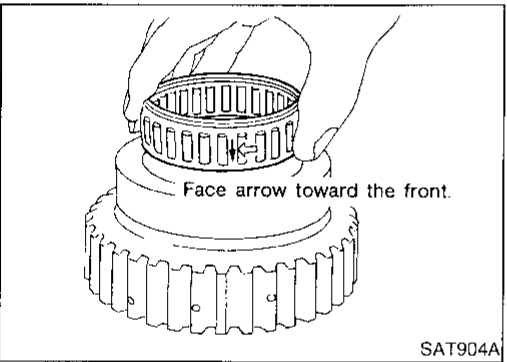

3. Install forward one-way clutch onto clutch hub.

- Install forward one-way clutch with flange facing rearward.

4. Install end bearing.

5. Install snap ring onto forward clutch hub.

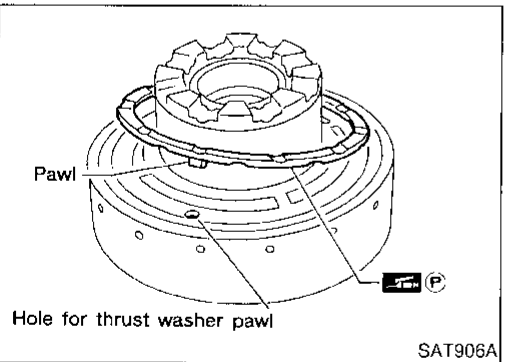

6. Install thrust washer onto rear internal gear.

- Apply petroleum jelly to thrust washer.

- Securely insert pawls of thrust washer into holes in rear internal gear.

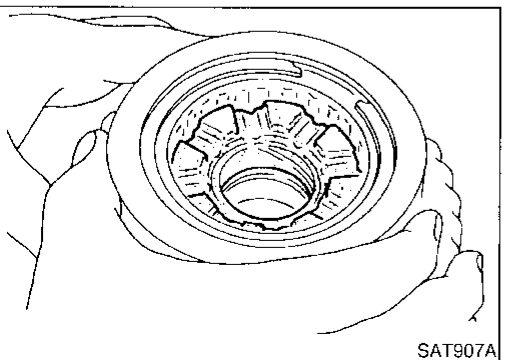

7. Position forward clutch hub in rear internal gear.

REPAIR FOR COMPONENT PARTS

Rear Internal Gear and Forward Clutch Hub (Cont'd)

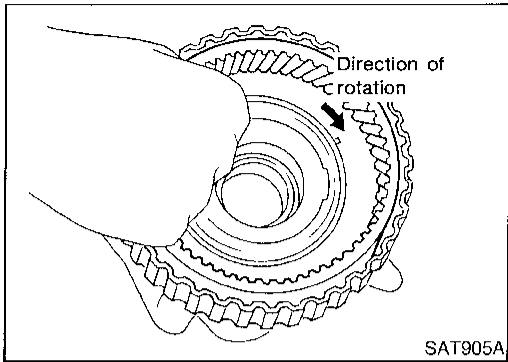

SAT905A

- After installing, check to assure that forward clutch hub rotates clockwise.

Band Servo Piston Assembly COMPONENTS

NAAT0148

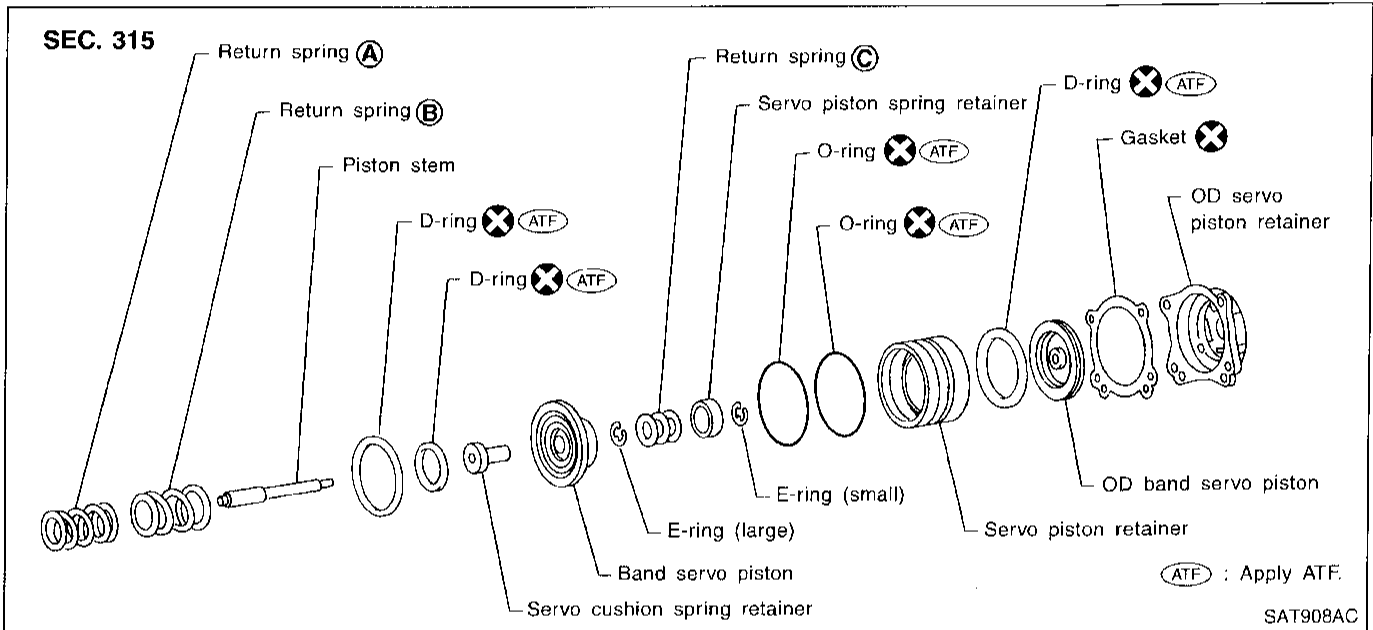

SAT908AC

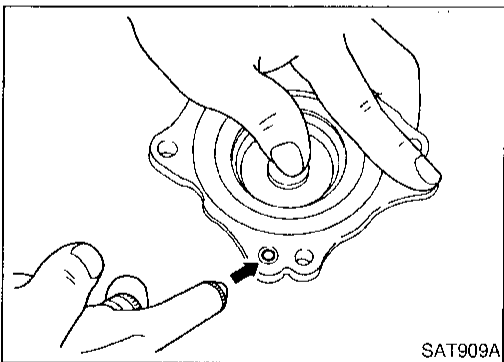

SAT909A

DISASSEMBLY

NAAT0149

- Block one oil hole in OD servo piston retainer and the center hole in OD band servo piston.
- Apply compressed air to the other oil hole in piston retainer to remove OD band servo piston from retainer.
- Remove D-ring from OD band servo piston.
- Remove band servo piston assembly from servo piston retainer by pushing it forward.

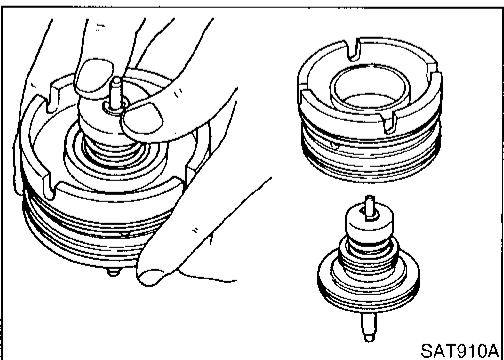

SAT910A

REPAIR FOR COMPONENT PARTS

Band Servo Piston Assembly (Cont'd)

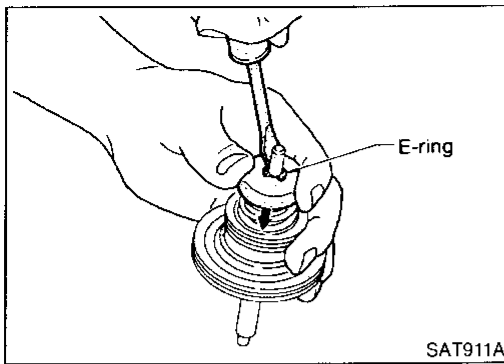

- Place piston stem end on a wooden block. While pushing servo piston spring retainer down, remove E-ring.

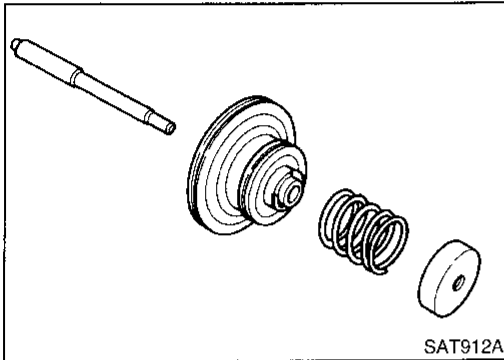

- Remove servo piston spring retainer, return spring C and piston stem from band servo piston.

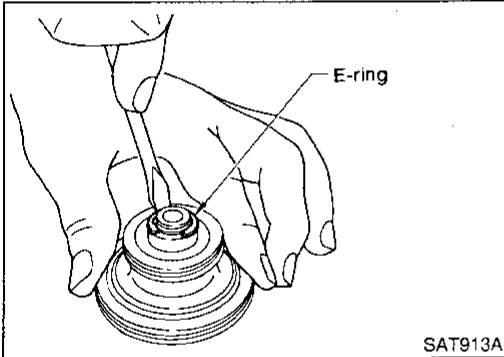

- Remove E-ring from band servo piston.

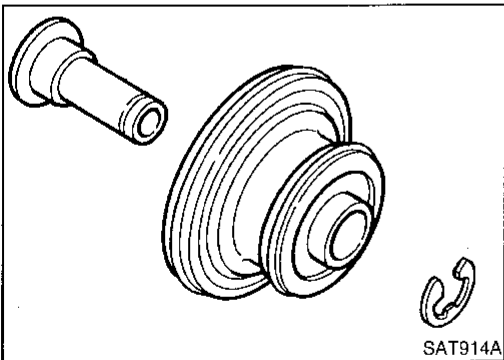

- Remove servo cushion spring retainer from band servo piston.
- Remove D-rings from band servo piston.
- Remove O-rings from servo piston retainer.

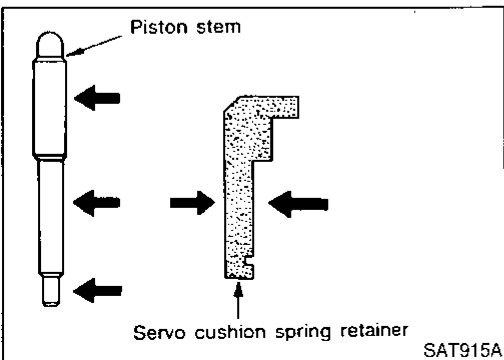

INSPECTION

Pistons, Retainers and Piston Stem

- Check frictional surfaces for abnormal wear or damage.

NAAT0150
NAAT0150S01

GI
MA
EM
LC
EC
FE
CL
MT
AT
TF
PD
AX
SU
BR
ST
RS
BT
HA
SC
EL
IDX

REPAIR FOR COMPONENT PARTS

Band Servo Piston Assembly (Cont'd)

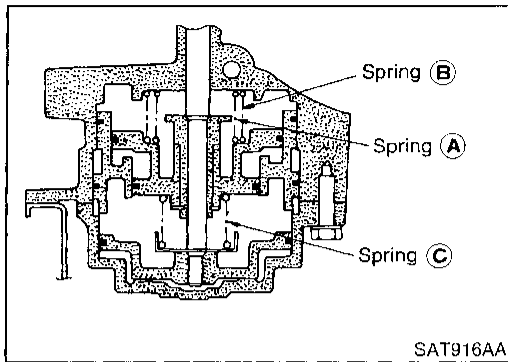

Return Springs

- Check for deformation or damage. Measure free length and outer diameter.

Inspection standard:

Refer to SDS, AT-308.

NAAT0150S02

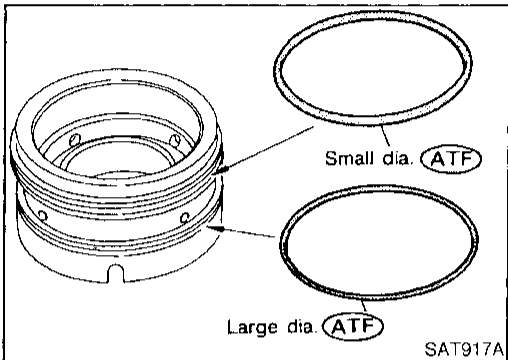

ASSEMBLY

1. Install O-rings onto servo piston retainer.
- Apply ATF to O-rings.
 - Pay attention to position of each O-ring.

NAAT0151

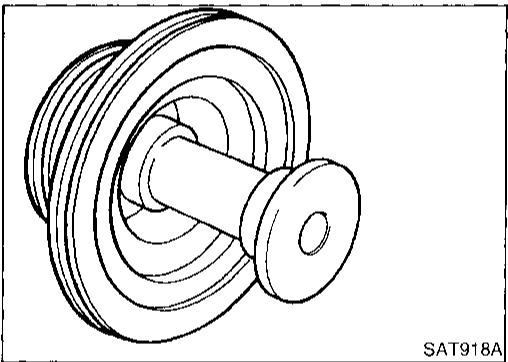

2. Install servo cushion spring retainer onto band servo piston.

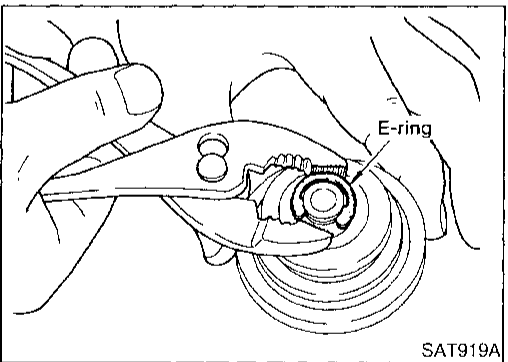

3. Install E-ring onto servo cushion spring retainer.

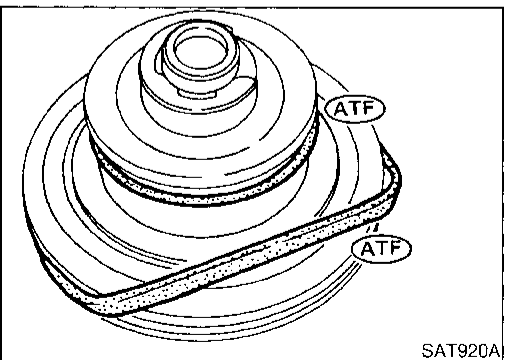

4. Install D-rings onto band servo piston.
- Apply ATF to D-rings.

REPAIR FOR COMPONENT PARTS

Band Servo Piston Assembly (Cont'd)

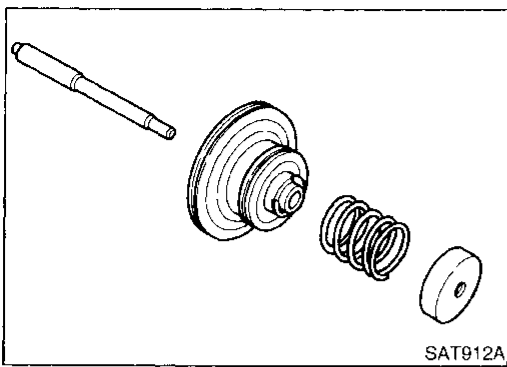

5. Install servo piston spring retainer, return spring C and piston stem onto band servo piston.

GI

MA

EM

LC

EC

FE

CL

MT

AT

TF

PD

AX

SU

BR

ST

RS

BT

HA

SC

EL

IDX

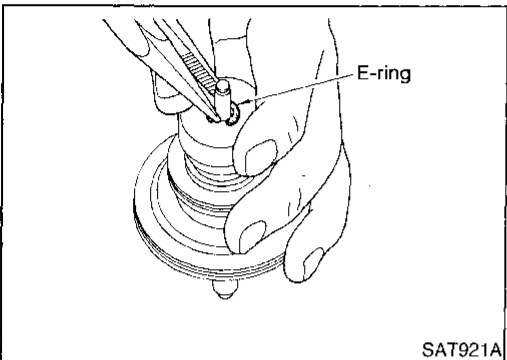

6. Place piston stem end on a wooden block. While pushing servo piston spring retainer down, install E-ring.

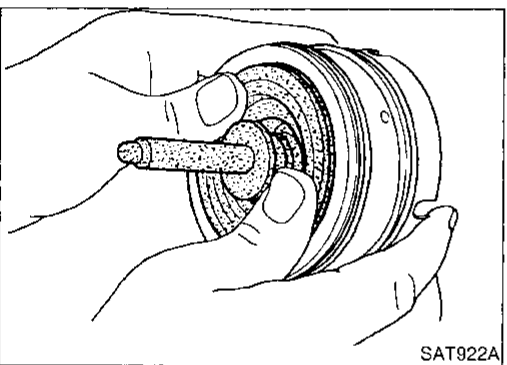

7. Install band servo piston assembly onto servo piston retainer by pushing it inward.

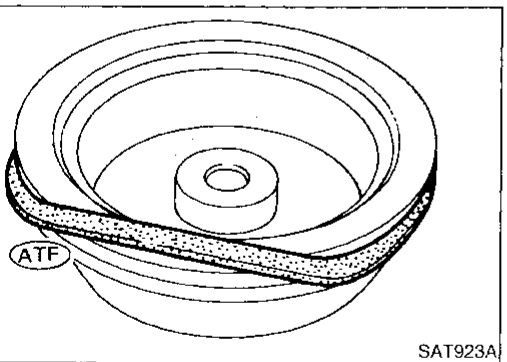

8. Install D-ring on OD band servo piston.
● **Apply ATF to D-ring.**

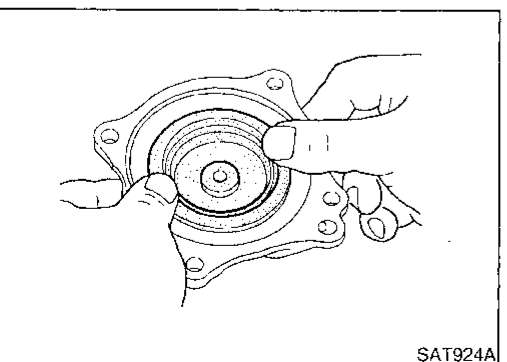

9. Install OD band servo piston onto servo piston retainer by pushing it inward.

REPAIR FOR COMPONENT PARTS

Parking Pawl Components COMPONENTS

NAAT0152

SEC. 311-314

2WD

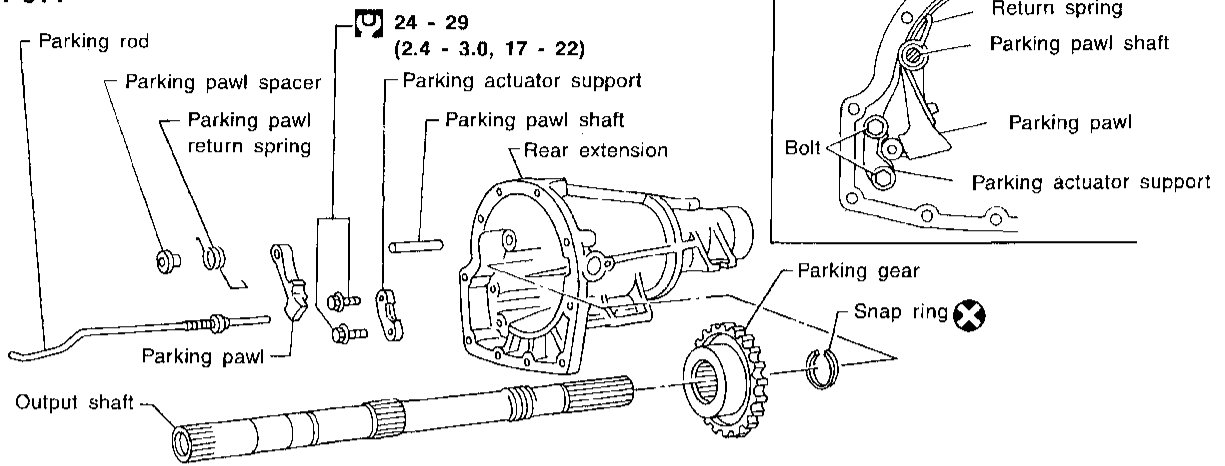

4WD

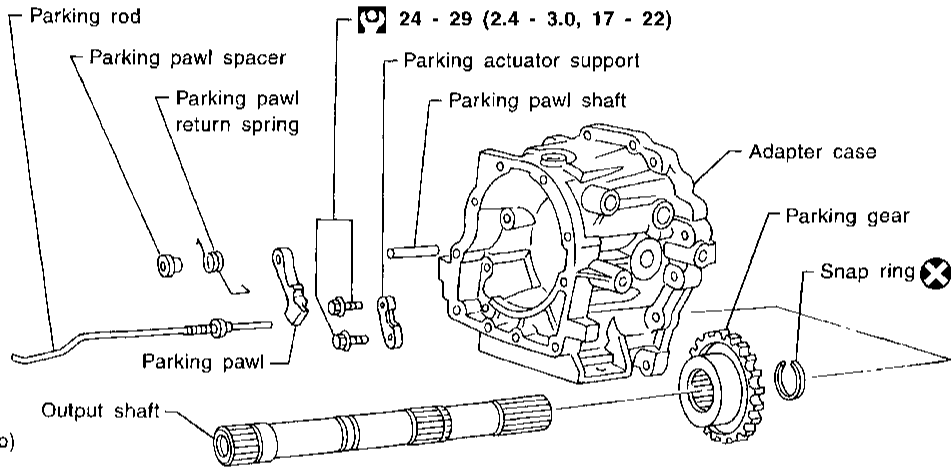

: N·m (kg-m, ft-lb)

SAT379I

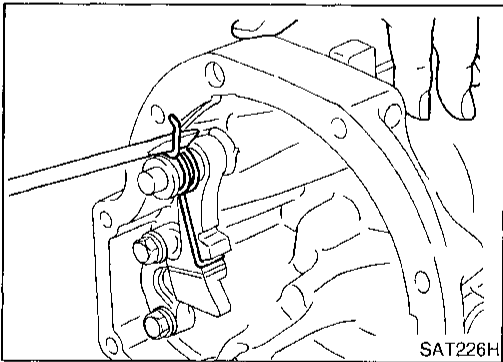

SAT226H

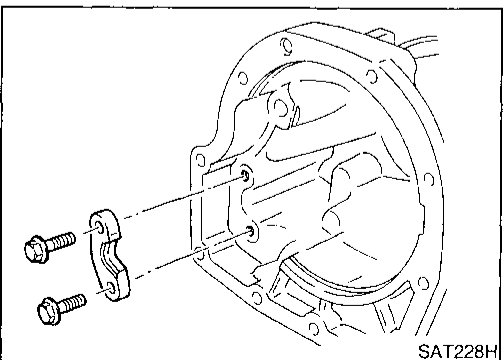

SAT228H

DISASSEMBLY

NAAT0153

1. Slide return spring to the front of rear extension case flange or adapter case flange.
2. Remove return spring, pawl spacer and parking pawl from rear extension or adapter case.
3. Remove parking pawl shaft from rear extension or adapter case.
4. Remove parking actuator support from rear extension or adapter case.

REPAIR FOR COMPONENT PARTS

Parking Pawl Components (Cont'd)

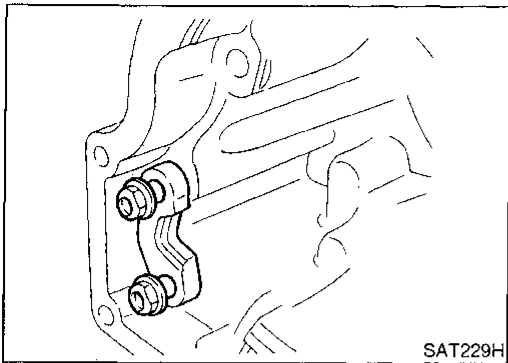

ASSEMBLY

1. Install parking actuator support onto rear extension or adapter case.
2. Insert parking pawl shaft into rear extension or adapter case.
3. Install return spring, pawl spacer and parking pawl onto parking pawl shaft.

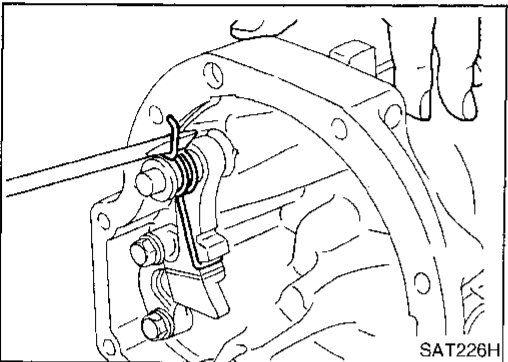

4. Bend return spring upward and install it onto rear extension or adapter case.

GI

MA

EM

LC

EC

FE

CL

MT

AT

TF

PD

AX

SU

BR

ST

RS

BT

HA

SC

EL

IDX

ASSEMBLY

Assembly (1)

NAAT0155

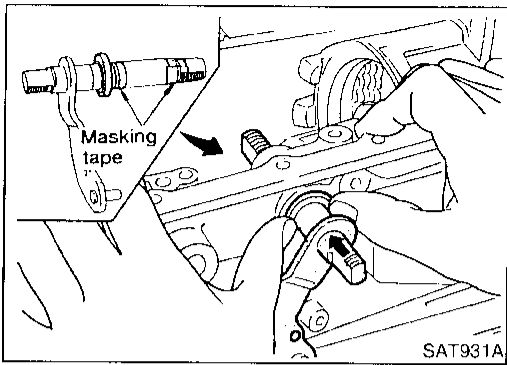

Assembly (1)

1. Install manual shaft components.
 - a. Install oil seal onto manual shaft.
 - **Apply ATF to oil seal.**
 - **Wrap threads of manual shaft with masking tape.**
 - b. Insert manual shaft and oil seal as a unit into transmission case.
 - c. Remove masking tape.

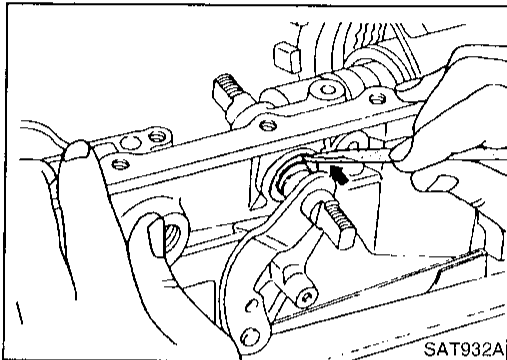

- d. Push oil seal evenly and install it onto transmission case.

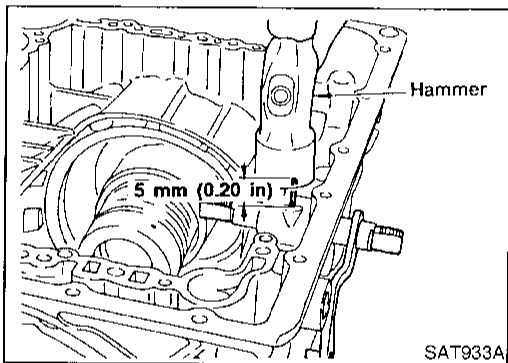

- e. Align groove in shaft with drive pin hole, then drive pin into position as shown in figure at left.

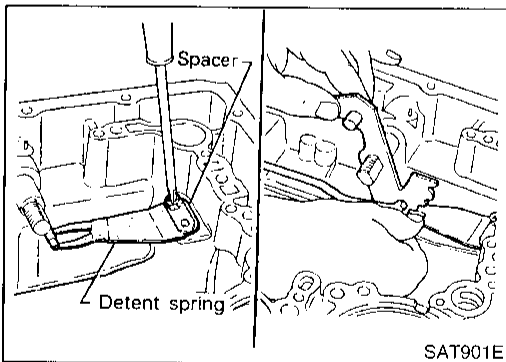

- f. Install detent spring and spacer.
 - g. While pushing detent spring down, install manual plate onto manual shaft.

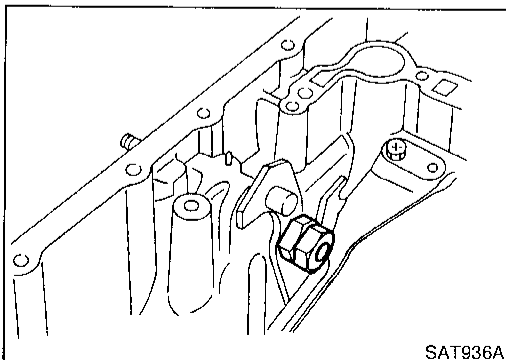

- h. Install lock nuts onto manual shaft.

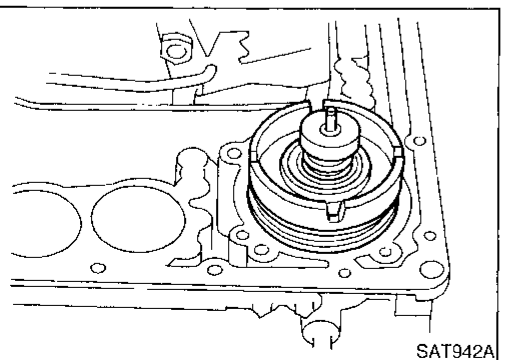
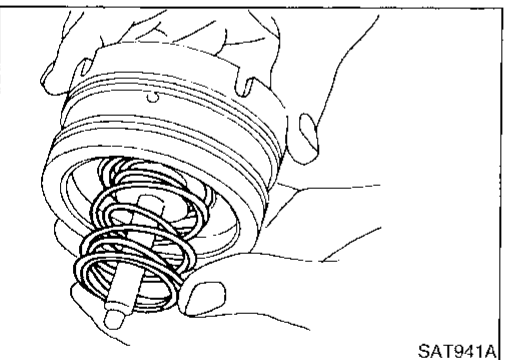
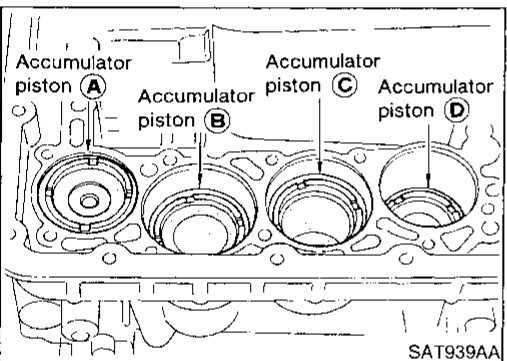
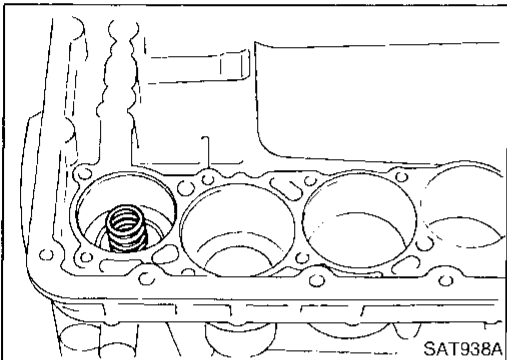
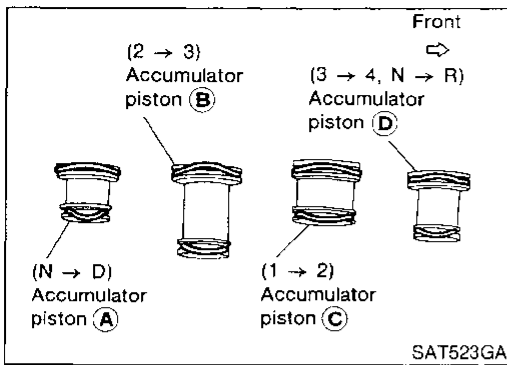

2. Install accumulator piston.
 - a. Install O-rings onto accumulator piston.
 - **Apply ATF to O-rings.**

Accumulator piston O-rings

Unit: mm (in)

Accumulator	A	B	C	D
Small diameter end	29 (1.14)	32 (1.26)	45 (1.77)	29 (1.14)
Large diameter end	45 (1.77)	50 (1.97)	50 (1.97)	45 (1.77)

- b. Install return spring for accumulator A onto transmission case.
 - Free length of return spring:**
Refer to SDS, AT-308.

- c. Install accumulator pistons A, B, C and D.
 - **Apply ATF to transmission case.**

3. Install band servo piston.
 - a. Install return springs onto servo piston.

- b. Install band servo piston onto transmission case.
 - **Apply ATF to O-ring of band servo piston and transmission case.**
- c. Install gasket for band servo onto transmission case.

GI
MA
EM
LC
EC
FE
CL
MT
AT
TF
PD
AX
SU
BR
ST
RS
BT
HA
SC
EL
IDX

ASSEMBLY

Assembly (1) (Cont'd)

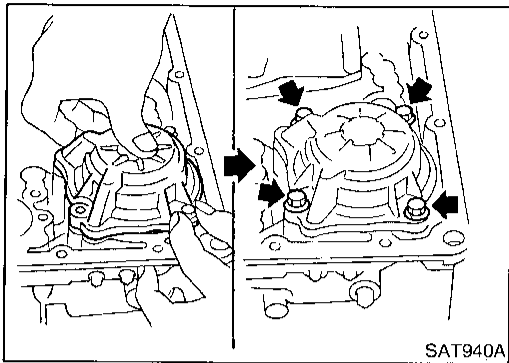

d. Install band servo retainer onto transmission case.

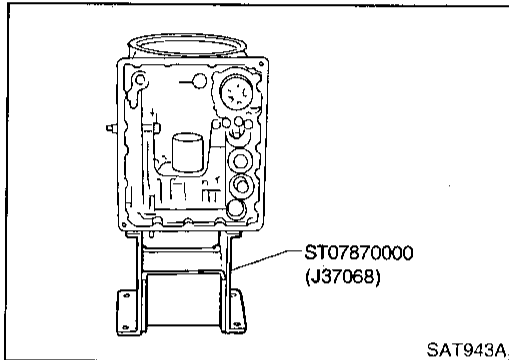

4. Install rear side clutch and gear components.

a. Place transmission case in vertical position.

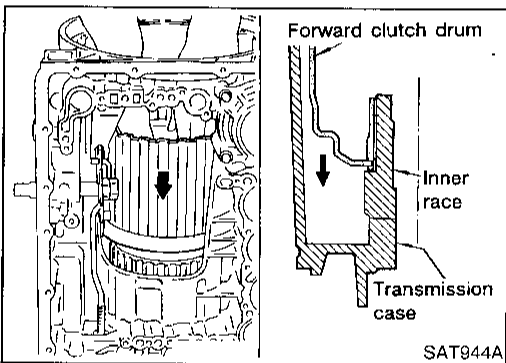

b. Slightly lift forward clutch drum assembly. Then slowly rotate it clockwise until its hub passes fully over clutch inner race inside transmission case.

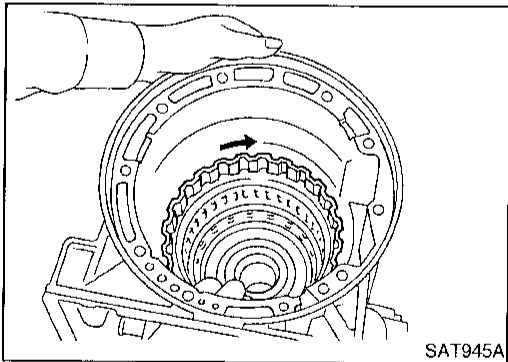

c. Check to be sure that rotation direction of forward clutch assembly is correct.

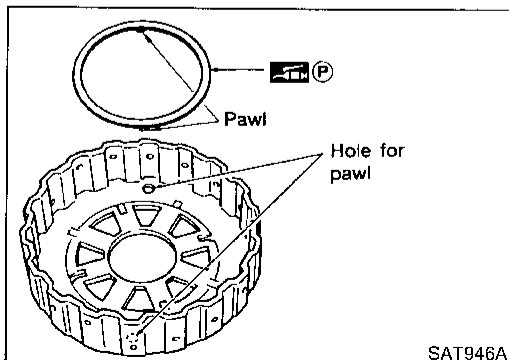

d. Install thrust washer onto front of overrun clutch hub.

- Apply petroleum jelly to the thrust washer.
- Insert pawls of thrust washer securely into holes in overrun clutch hub.

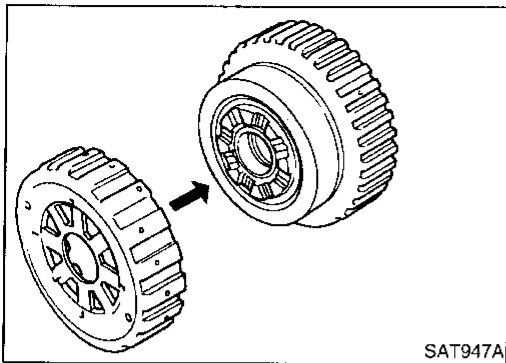

e. Install overrun clutch hub onto rear internal gear assembly.

GI

MA

EM

LC

EC

FE

CL

MT

AT

TF

PD

AX

SU

BR

ST

RS

BT

HA

SC

EL

IDX

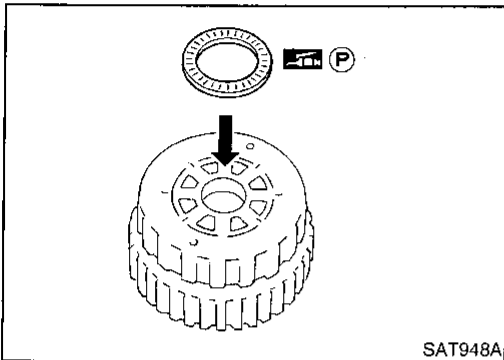

f. Install needle bearing onto rear of overrun clutch hub.

- Apply petroleum jelly to needle bearing.

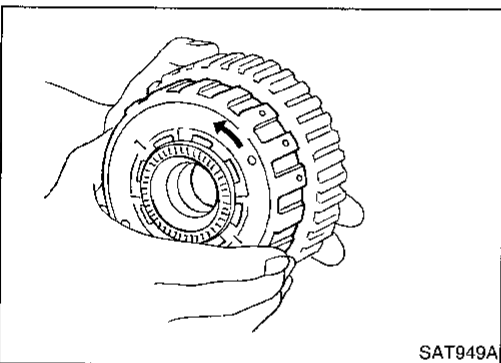

g. Check that overrun clutch hub rotates as shown while holding forward clutch hub.

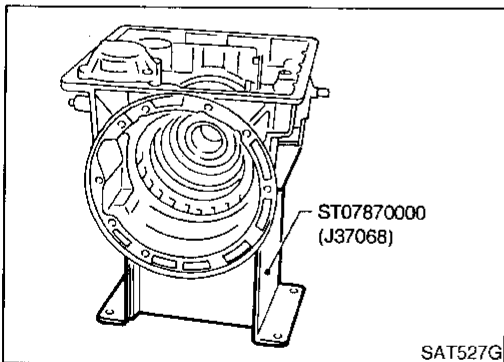

h. Place transmission case into horizontal position.

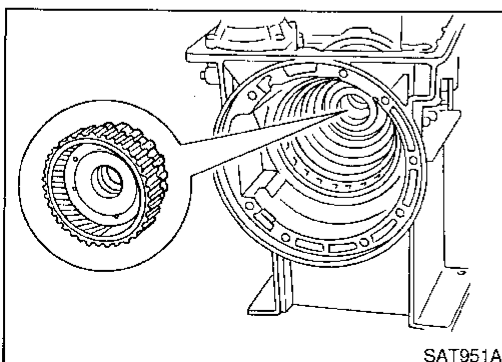

i. Install rear internal gear, forward clutch hub and overrun clutch hub as a unit onto transmission case.

ASSEMBLY

Assembly (1) (Cont'd)

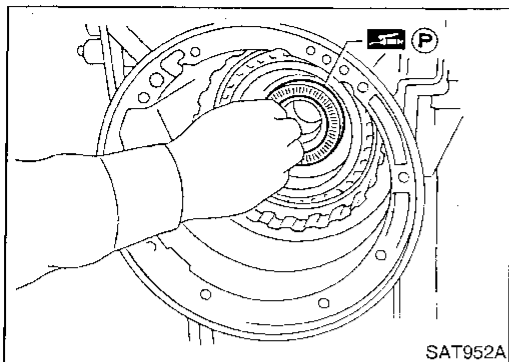

- j. Install needle bearing onto rear internal gear.
- **Apply petroleum jelly to needle bearing.**

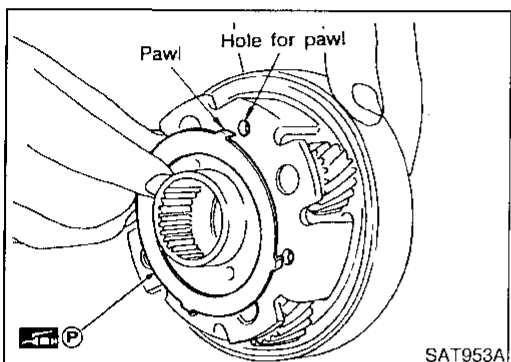

- k. Install bearing race onto rear of front internal gear.
- **Apply petroleum jelly to bearing race.**
 - **Securely engage pawls of bearing race with holes in front internal gear.**

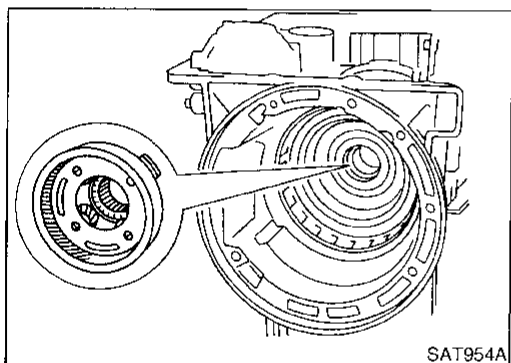

- l. Install front internal gear on transmission case.

Adjustment

When any parts listed in the following table are replaced, total end play or reverse clutch end play must be adjusted. NAAT0159

Part name	Total end play	Reverse clutch end play
Transmission case	●	●
Low one-way clutch inner race	●	●
Overrun clutch hub	●	●
Rear internal gear	●	●
Rear planetary carrier	●	●
Rear sun gear	●	●
Front planetary carrier	●	●
Front sun gear	●	●
High clutch hub	●	●
High clutch drum	●	●
Oil pump cover	●	●
Reverse clutch drum	—	●

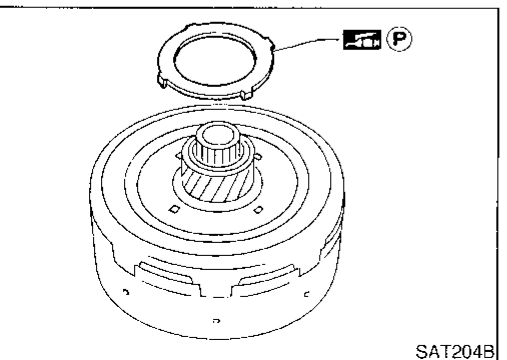
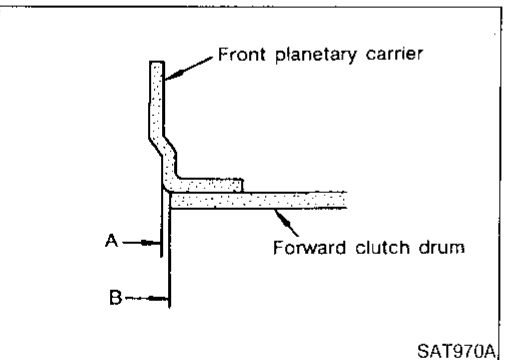
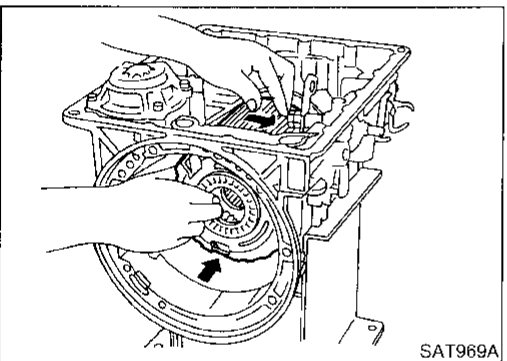
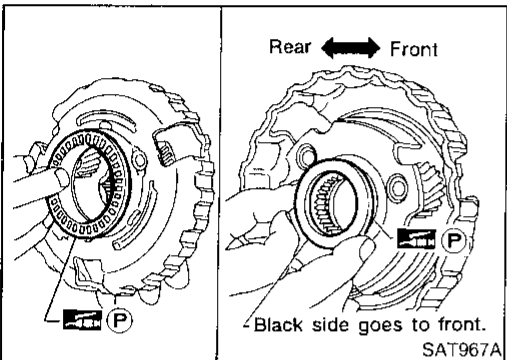
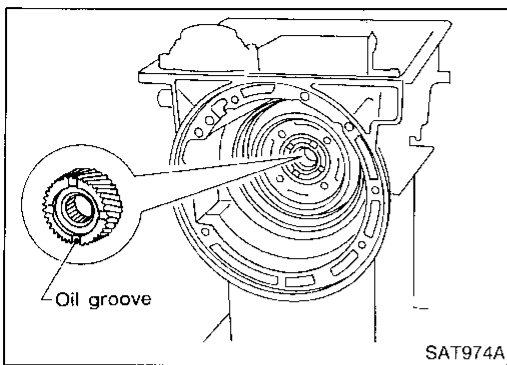

1. Install front side clutch and gear components.
 - a. Install rear sun gear on transmission case.
 - **Pay attention to its direction.**
 - b. Install needle bearing on front of front planetary carrier.
 - **Apply petroleum jelly to needle bearing.**
 - c. Install needle bearing on rear of front planetary carrier.
 - **Apply petroleum jelly to bearing.**
 - **Pay attention to its direction — Black side goes to front.**
 - d. While rotating forward clutch drum clockwise, install front planetary carrier on forward clutch drum.
 - **Check that portion A of front planetary carrier protrudes approximately 2 mm (0.08 in) beyond portion B of forward clutch assembly.**
 - e. Install bearing races on rear of clutch pack.
 - **Apply petroleum jelly to bearing races.**
 - **Securely engage pawls of bearing race with hole in clutch pack.**

GI
MA
EM
LC
EC
FE
CL
MT
AT
TF
PD
AX
SU
BR
ST
RS
BT
HA
SC
EL
DX

ASSEMBLY

Adjustment (Cont'd)

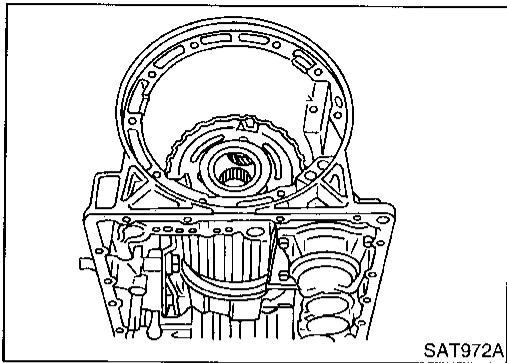

f. Place transmission case in vertical position.

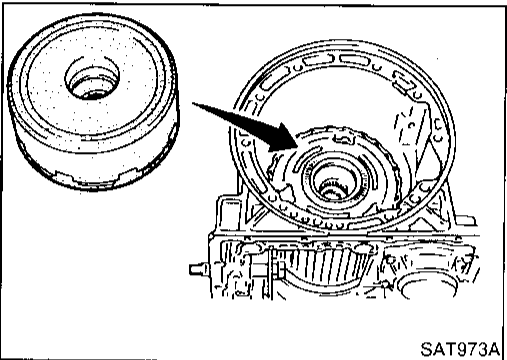

g. Install clutch pack into transmission case.

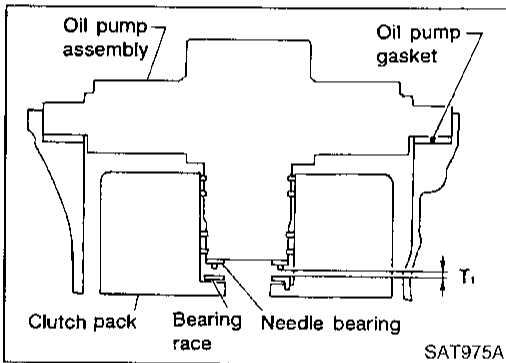

2. Adjust total end play.

Total end play " T_1 ":

0.25 - 0.55 mm (0.0098 - 0.0217 in)

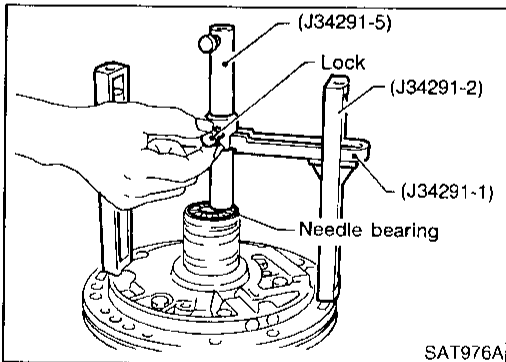

a. With needle bearing installed, place J34291-1 (bridge), J34291-2 (legs) and the J34291-5 (gauging cylinder) onto oil pump. The long ends of legs should be placed firmly on machined surface of oil pump assembly. The gauging cylinder should rest on top of the needle bearing. Lock gauging cylinder in place with set screw.

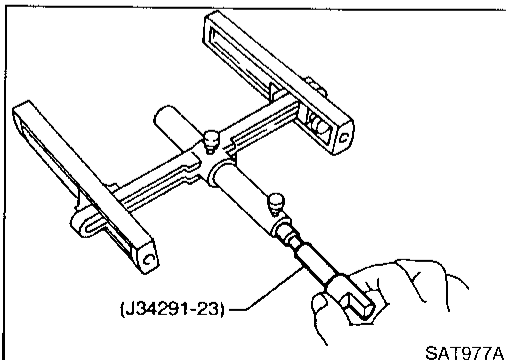

b. Install J34291-23 (gauging plunger) into gauging cylinder.

ASSEMBLY

Adjustment (Cont'd)

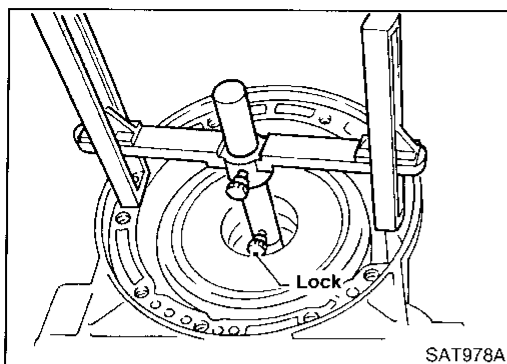

- c. Install original bearing race inside reverse clutch drum. Place shim selecting gauge with its legs on machined surface of transmission case (no gasket). Allow gauging plunger to rest on bearing race. Lock gauging plunger in place with set screw.

GI

MA

EM

LC

EC

FE

CL

MT

AT

TF

PD

AX

SU

BR

ST

RS

BT

HA

SC

EL

DX

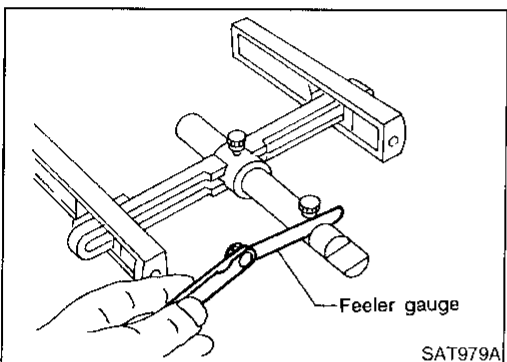

- d. Remove Tool and use feeler gauge to measure gap between gauging cylinder and gauging plunger. This measurement should give exact total end play.

Total end play "T₁":

0.25 - 0.55 mm (0.0098 - 0.0217 in)

- If end play is out of specification, decrease or increase thickness of oil pump cover bearing race as necessary.

Available oil pump cover bearing race:

Refer to SDS, AT-311.

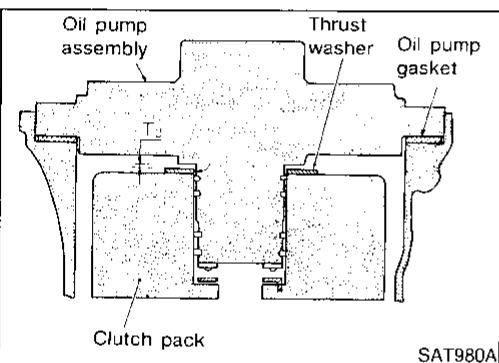

3. Adjust reverse clutch drum end play.

Reverse clutch drum end play "T₂":

0.55 - 0.90 mm (0.0217 - 0.0354 in)

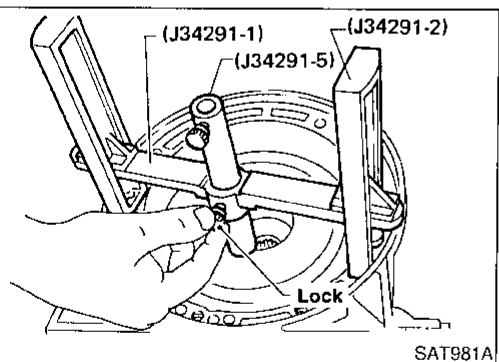

- a. Place J34291-1 (bridge), J34291-2 (legs) and J34291-5 (gauging cylinder) on machined surface of transmission case (no gasket). Allow gauging cylinder to rest on front thrust surface of reverse clutch drum. Lock cylinder in place with set screw.

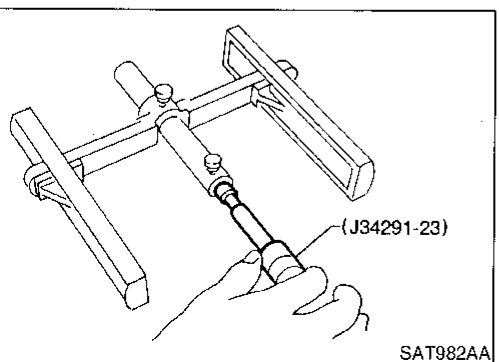

- b. Install J34291-23 (gauging plunger) into gauging cylinder.

ASSEMBLY

Adjustment (Cont'd)

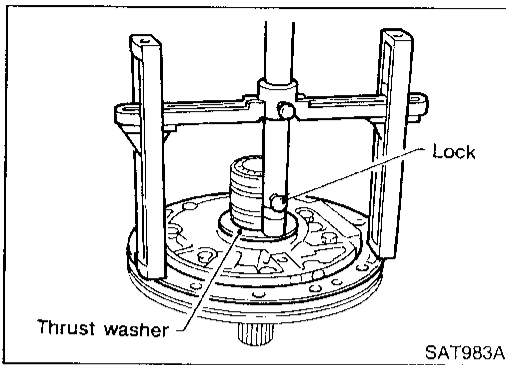

- c. Install original thrust washer on oil pump. Place shim setting gauge legs onto machined surface of oil pump assembly. Allow gauging plunger to rest on thrust washer. Lock plunger in place with set screw.

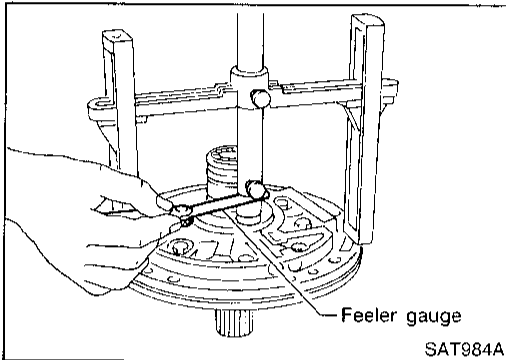

- d. Use feeler gauge to measure gap between gauging plunger and gauging cylinder. This measurement should give you exact reverse clutch drum end play.

Reverse clutch drum end play "T₂":
0.55 - 0.90 mm (0.0217 - 0.0354 in)

- If end play is out of specification, decrease or increase thickness of oil pump thrust washer as necessary.

Available oil pump thrust washer:
Refer to SDS, AT-312.

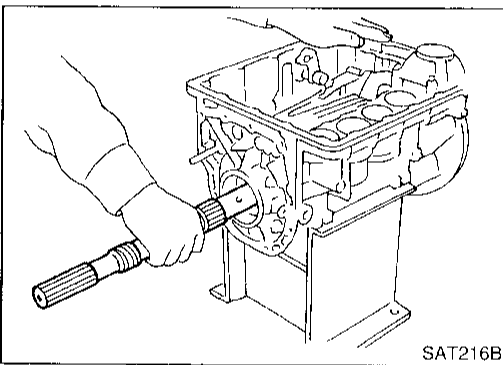

Assembly (2)

NAATD157

1. Install output shaft and parking gear.
- a. Insert output shaft from rear of transmission case while slightly lifting front internal gear.
 - **Do not force output shaft against front of transmission case.**

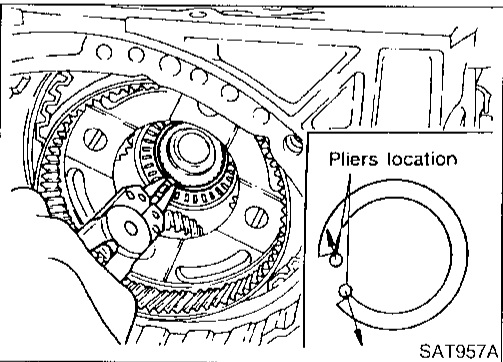

- b. Carefully push output shaft against front of transmission case. Install snap ring on front of output shaft.
 - **Check to be sure output shaft cannot be removed in rear direction.**

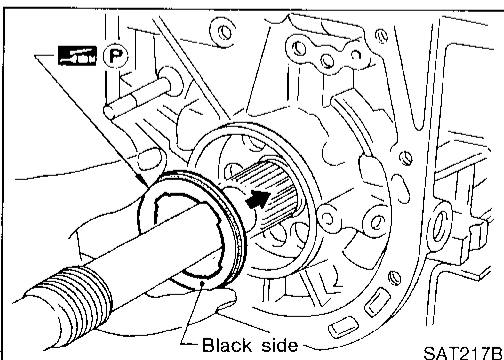

- c. Install needle bearing on transmission case.
 - **Pay attention to its direction — Black side goes to rear.**
 - **Apply petroleum jelly to needle bearing.**

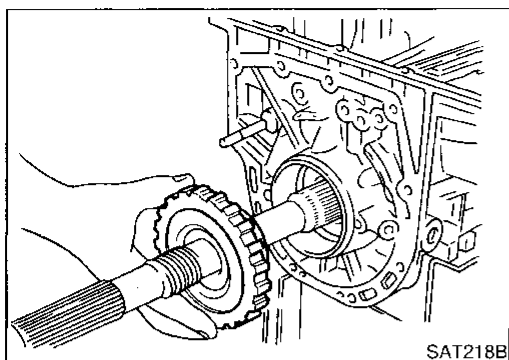

d. Install parking gear on transmission case.

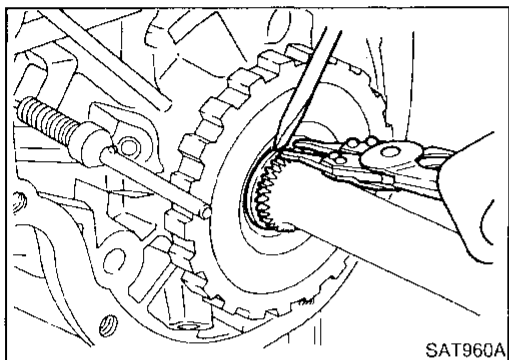

e. Install snap ring on rear of output shaft.
 ● Check to be sure output shaft cannot be removed in forward direction.

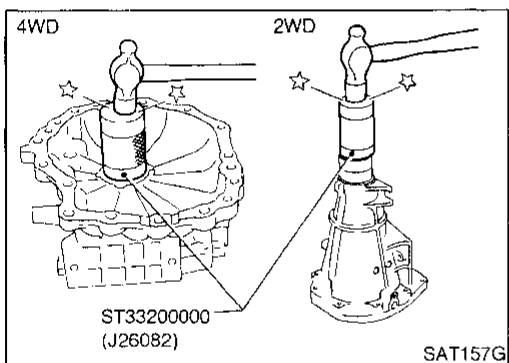

2. Install rear extension or adapter case.
 a. Install oil seal on rear extension or adapter case.
 ● Apply ATF to oil seal.

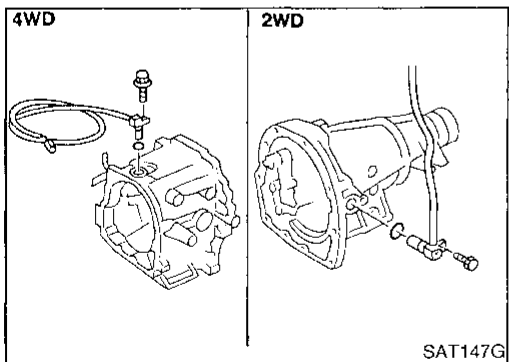

b. Install O-ring on revolution sensor.
 ● Apply ATF to O-ring.
 c. Install revolution sensor on rear extension or adapter case.

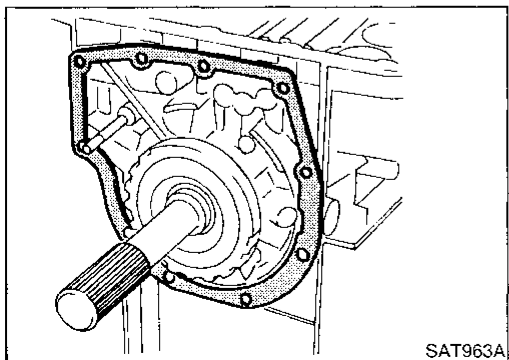

d. Install rear extension gasket on transmission case.

GI
 MA
 EM
 LC
 EC
 FE
 CL
 MT
AT
 TF
 PD
 AX
 SU
 BR
 ST
 RS
 BT
 HA
 SC
 EL
 IDX

ASSEMBLY

Assembly (2) (Cont'd)

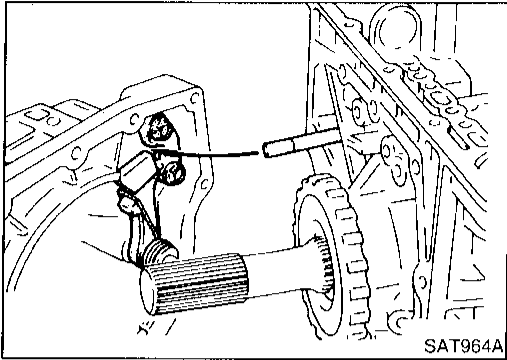

e. Install parking rod on transmission case.

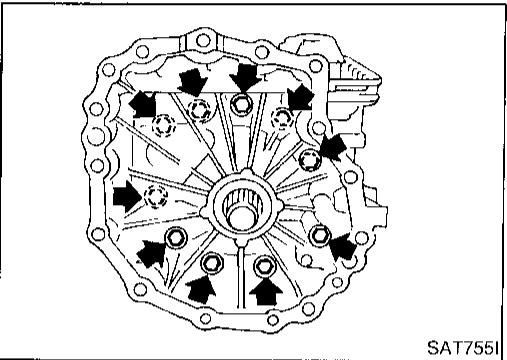

f. Install rear extension or adapter case on transmission case.

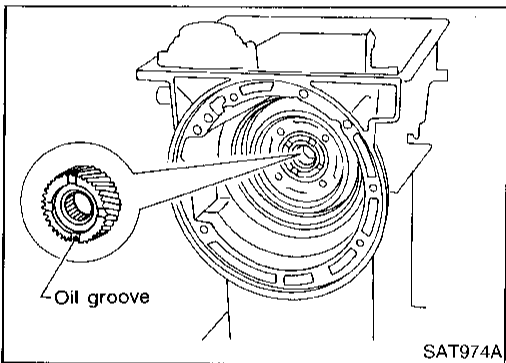

3. Install front side clutch and gear components.
- a. Install rear sun gear on transmission case.
- **Pay attention to its direction.**

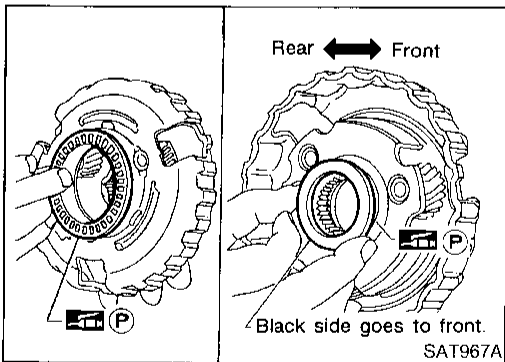

- b. Make sure needle bearing is on front of front planetary carrier.
- **Apply petroleum jelly to needle bearing.**
- c. Make sure needle bearing is on rear of front planetary carrier.
- **Apply petroleum jelly to bearing.**
- **Pay attention to its direction — Black side goes to front.**

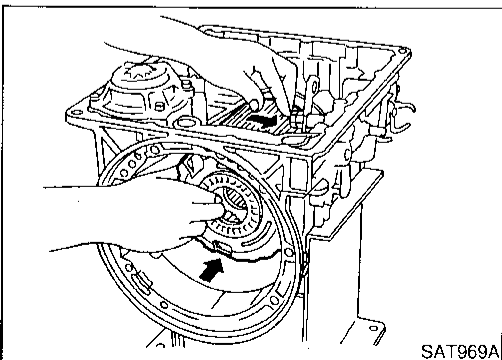

d. While rotating forward clutch drum clockwise, install front planetary carrier on forward clutch drum.

ASSEMBLY

Assembly (2) (Cont'd)

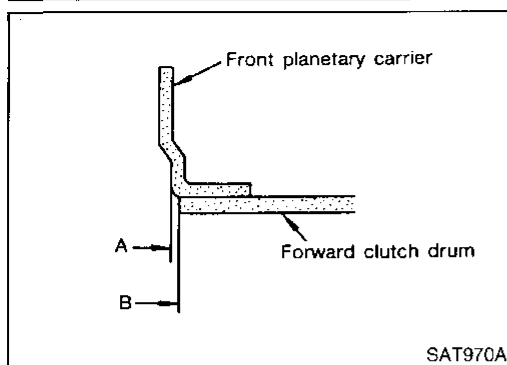

- Check that portion A of front planetary carrier protrudes approximately 2 mm (0.08 in) beyond portion B of forward clutch assembly.

GI

MA

EM

LC

EC

FE

CL

MT

AT

TF

PD

AX

SU

BR

ST

RS

BT

HA

SC

EL

IDX

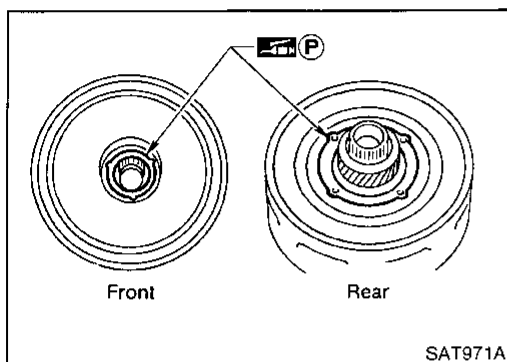

- e. Make sure bearing races are on front and rear of clutch pack.

- Apply petroleum jelly to bearing races.
- Securely engage pawls of bearing races with holes in clutch pack.

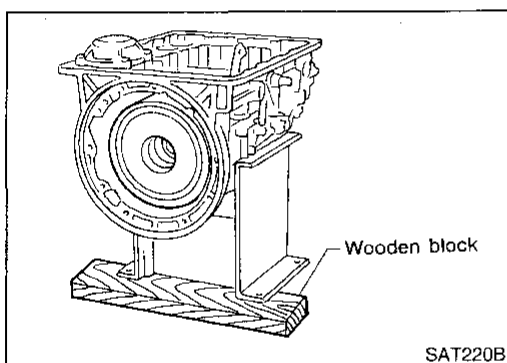

- f. Install clutch pack into transmission case.

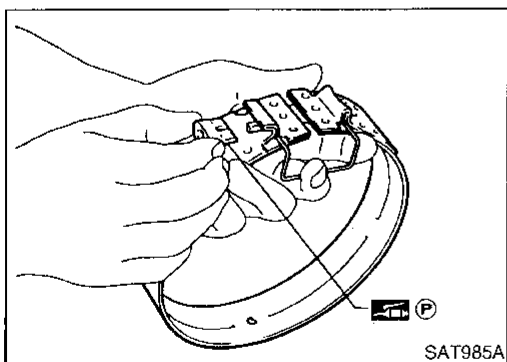

- 4. Install brake band and band strut.

- a. Install band strut on brake band.

- Apply petroleum jelly to band strut.

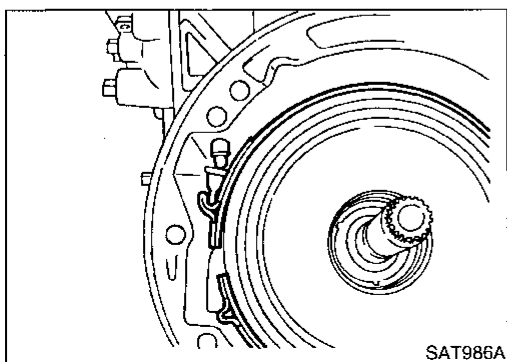

- b. Place brake band on periphery of reverse clutch drum, and insert band strut into end of band servo piston stem.

ASSEMBLY

Assembly (2) (Cont'd)

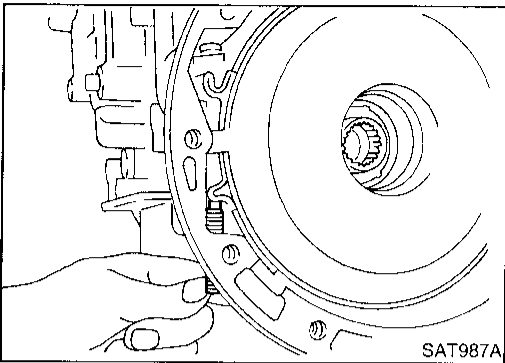

- c. Install anchor end bolt on transmission case. Then, tighten anchor end bolt just enough so that reverse clutch drum (clutch pack) will not tilt forward.

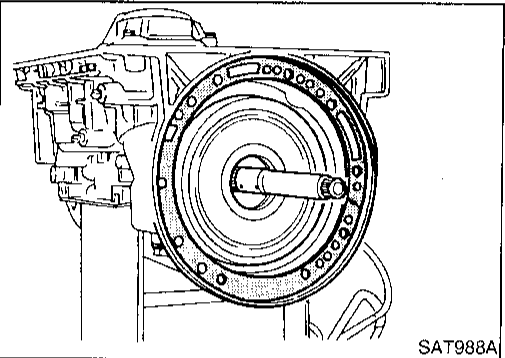

5. Install input shaft on transmission case.
 - **Pay attention to its direction — O-ring groove side is front.**
6. Install gasket on transmission case.

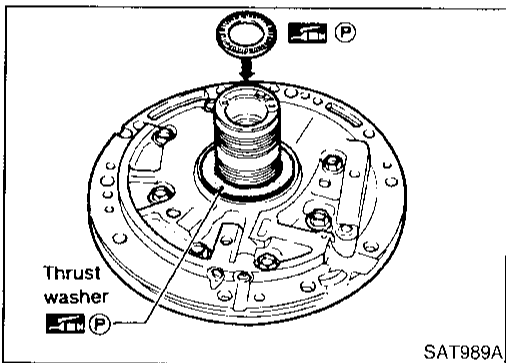

7. Install oil pump assembly.
 - a. Install needle bearing on oil pump assembly.
 - **Apply petroleum jelly to the needle bearing.**
 - b. Install selected thrust washer on oil pump assembly.
 - **Apply petroleum jelly to thrust washer.**

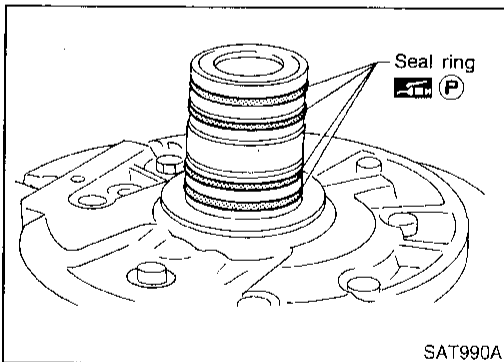

- c. Carefully install seal rings into grooves and press them into the petroleum jelly so that they are a tight fit.

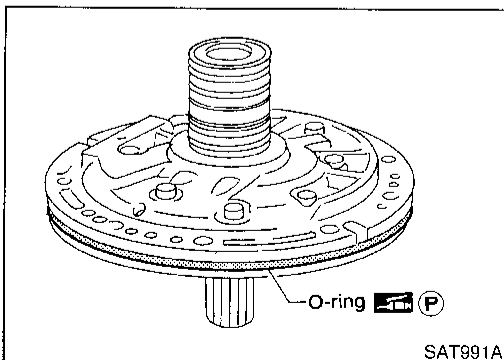

- d. Install O-ring on oil pump assembly.
 - **Apply petroleum jelly to O-ring.**

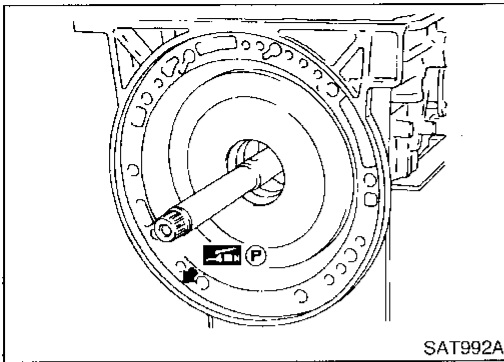

- e. Apply petroleum jelly to mating surface of transmission case and oil pump assembly.

GI

MA

EM

LC

EC

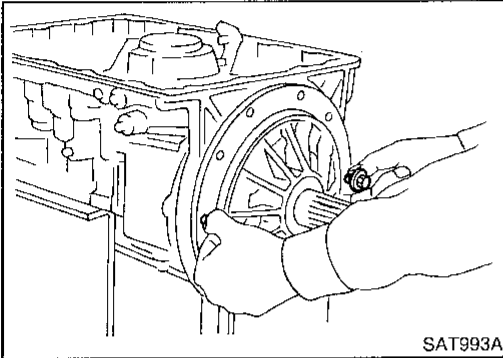

- f. Install oil pump assembly.
- Install two converter housing securing bolts in bolt holes in oil pump assembly as guides.

FE

CL

MT

AT

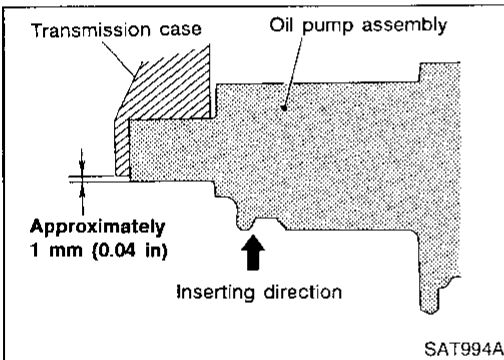

- Insert oil pump assembly to the specified position in transmission, as shown at left.

TF

PD

AX

SU

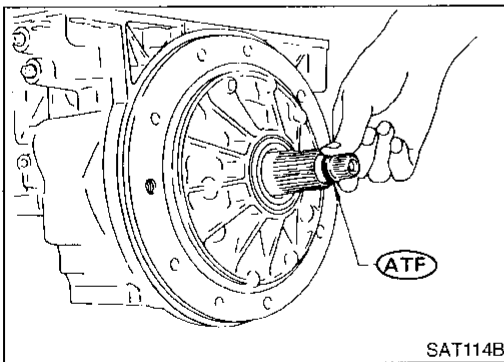

8. Install O-ring on input shaft.
- Apply ATF to O-rings.

BR

ST

RS

BT

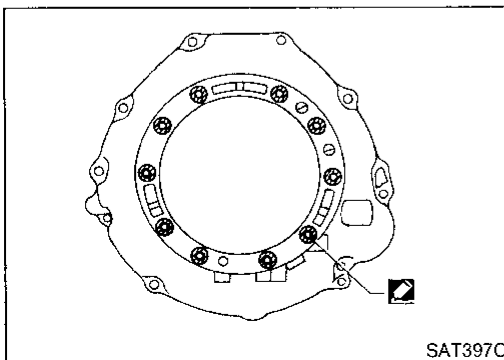

9. Install converter housing.
- a. Apply recommended sealant (Genuine anaerobic liquid gasket, Three Bond TB1215, Loctite Part No. 51813 or equivalent) to outer periphery of bolt holes in converter housing.
- Do not apply too much sealant.

HA

SC

EL

IDX

ASSEMBLY

Assembly (2) (Cont'd)

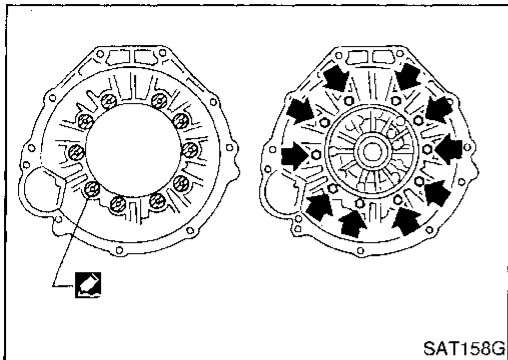

SAT158G

- b. Apply recommended sealant (Genuine anaerobic liquid gasket, Three Bond TB1215, Loctite Part No. 51813 or equivalent) to seating surfaces of bolts that secure front of converter housing.
- c. Install converter housing on transmission case.

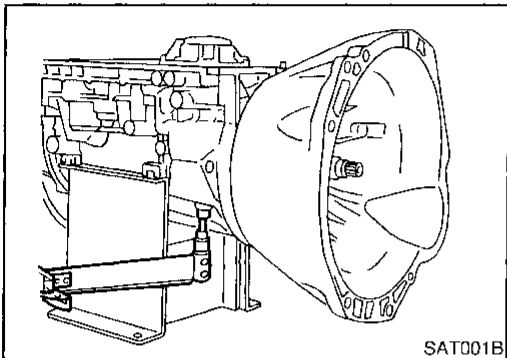

SAT001B

10. Adjust brake band.
 - a. Tighten anchor end bolt to specified torque.
Anchor end bolt:
☑ : 4 - 6 N·m (0.4 - 0.6 kg-m, 35 - 52 in-lb)
 - b. Back off anchor end bolt two and a half turns.

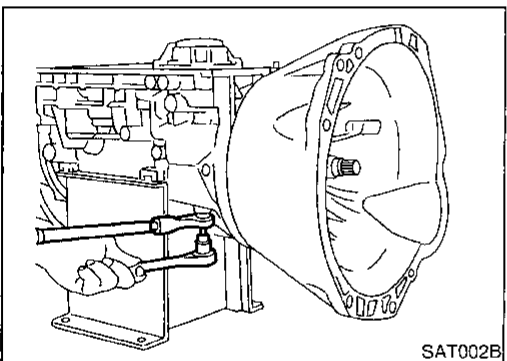

SAT002B

- c. While holding anchor end pin, tighten lock nut.

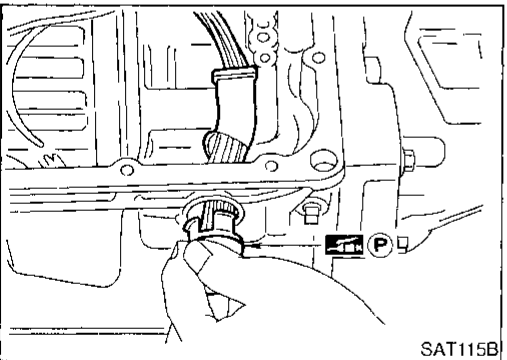

SAT115B

11. Install terminal cord assembly.
 - a. Install O-ring on terminal cord assembly.
 - **Apply petroleum jelly to O-ring.**
 - b. Compress terminal cord assembly stopper and install terminal cord assembly on transmission case.

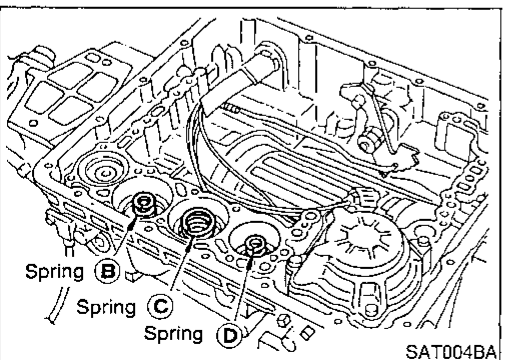

SAT004BA

12. Install control valve assembly.
 - a. Install accumulator piston return springs B, C and D.
Free length of return springs:
Refer to SDS, AT-308.

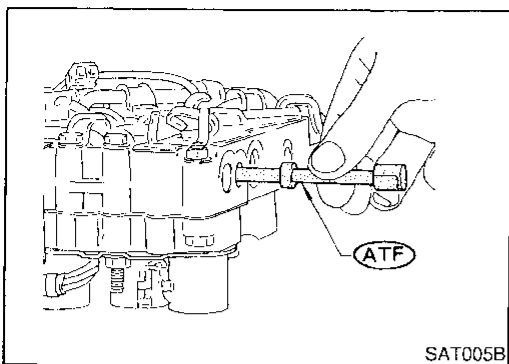

b. Install manual valve on control valve.

- **Apply ATF to manual valve.**

GI

MA

EM

LC

EC

FE

CL

MT

AT

TF

PD

AX

SU

BR

ST

RS

BT

HA

SC

EL

IDX

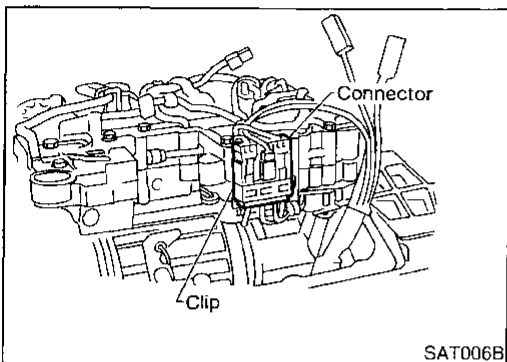

c. Place control valve assembly on transmission case. Connect solenoid connector for upper body.

d. Install connector clip.

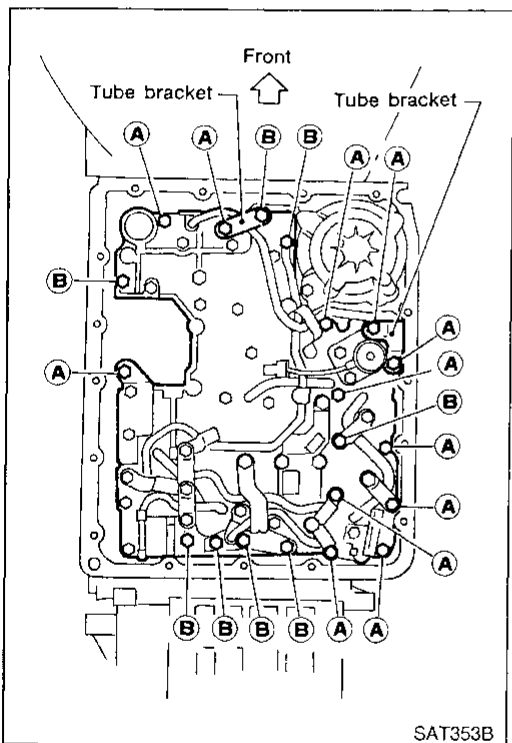

e. Install control valve assembly on transmission case.

f. Install connector tube brackets and tighten bolts A and B.

- **Check that terminal assembly does not catch.**

Bolt symbol	ℓ mm (in)
A	33 (1.30)
B	45 (1.77)

RS

BT

HA

SC

EL

IDX

IDX

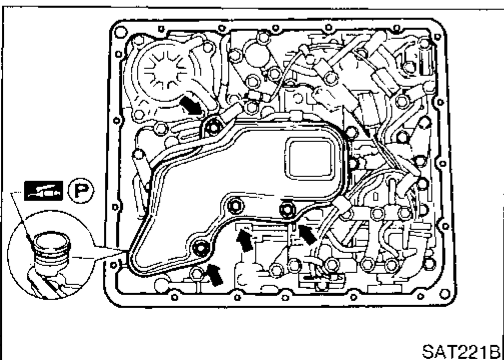

g. Install O-ring on oil strainer.

- **Apply petroleum jelly to O-ring.**

h. Install oil strainer on control valve.

ASSEMBLY

Assembly (2) (Cont'd)

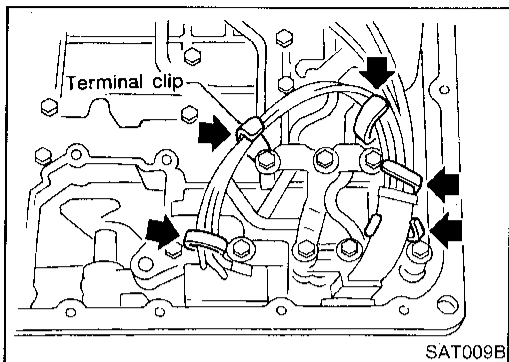

i. Securely fasten terminal harness with clips.

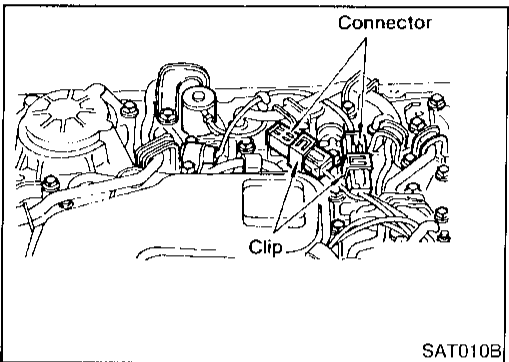

j. Install torque converter clutch solenoid valve and fluid temperature sensor connectors.

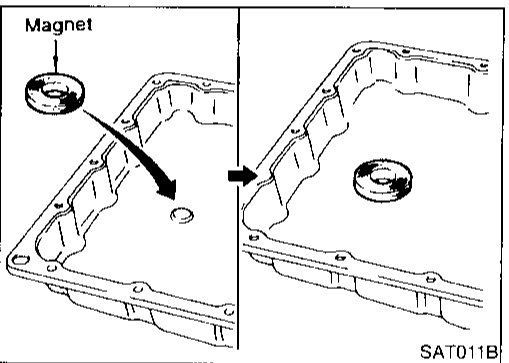

13. Install oil pan.

a. Attach a magnet to oil pan.

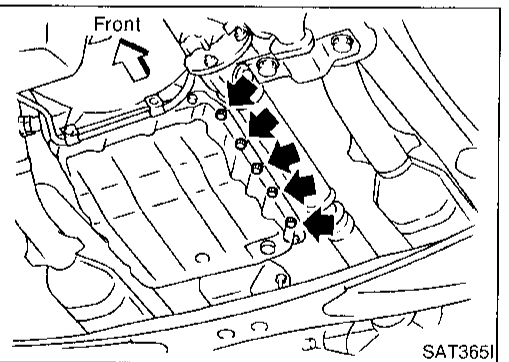

b. Install new oil pan gasket on transmission case.

c. Install oil pan and bracket on transmission case.

• **Always replace oil pan bolts as they are self-sealing bolts.**

• **Before installing bolts, remove traces of sealant and oil from mating surface and thread holes.**

• **Tighten four bolts in a criss-cross pattern to prevent dislocation of gasket.**

d. Tighten drain plug.

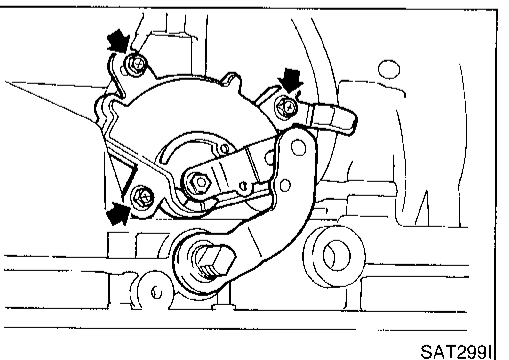

14. Install inhibitor switch.

a. Check that manual shaft is in "1" position.

b. Temporarily install inhibitor switch on manual shaft.

c. Move manual shaft to "N".

ASSEMBLY

Assembly (2) (Cont'd)

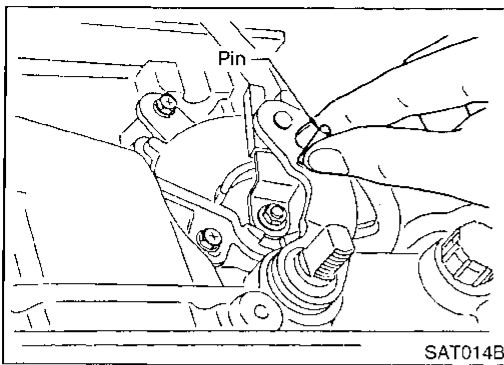

- d. Tighten bolts while inserting 4.0 mm (0.157 in) dia. pin vertically into locating holes in inhibitor switch and manual shaft.

GI
MA
EM
LC

EC

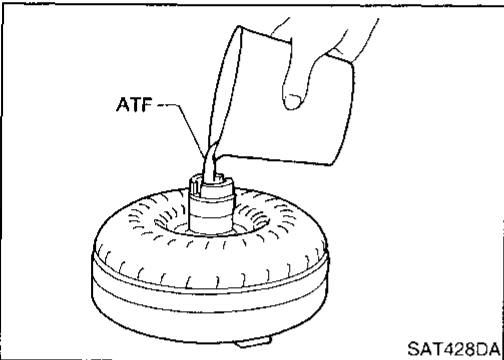

15. Install torque converter.
- a. Pour ATF into torque converter.
- **Approximately 2 liters (2-1/8 US qt, 1-3/4 Imp qt) of fluid are required for a new torque converter.**
 - **When reusing old torque converter, add the same amount of fluid as was drained.**

FE
CL

MT

AT

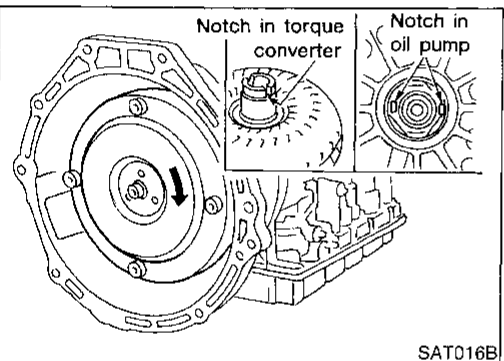

- b. Install torque converter while aligning notches and oil pump.

TF
PD

AX

SU

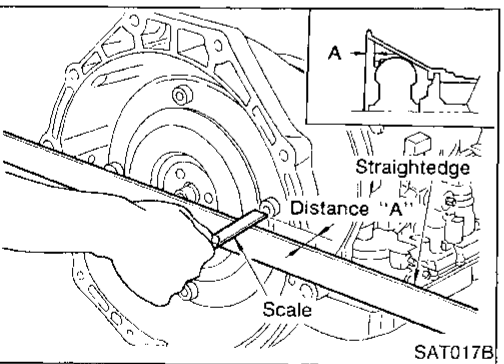

- c. Measure distance A to check that torque converter is in proper position.

Distance "A":
26.0 mm (1.024 in) or more

BR

ST

RS

BT

HA

SC

EL

IDX

A/T FLUID COOLER SYSTEM

A/T Fluid Cooler

A/T Fluid Cooler

NAAT0158

SEC. 310

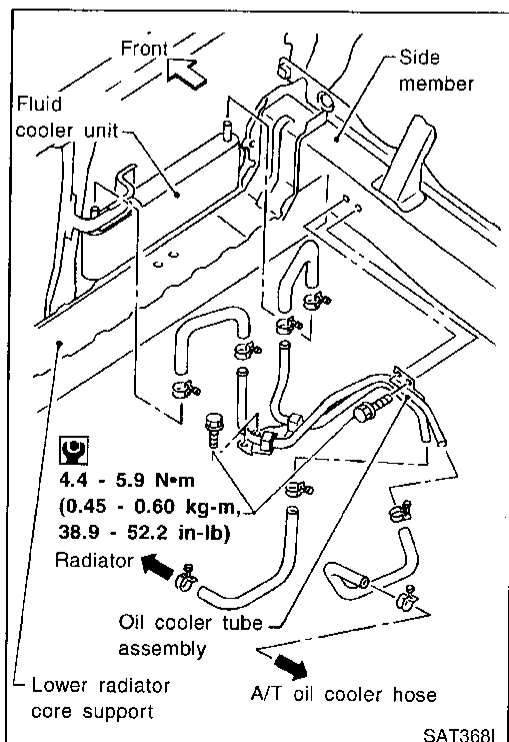
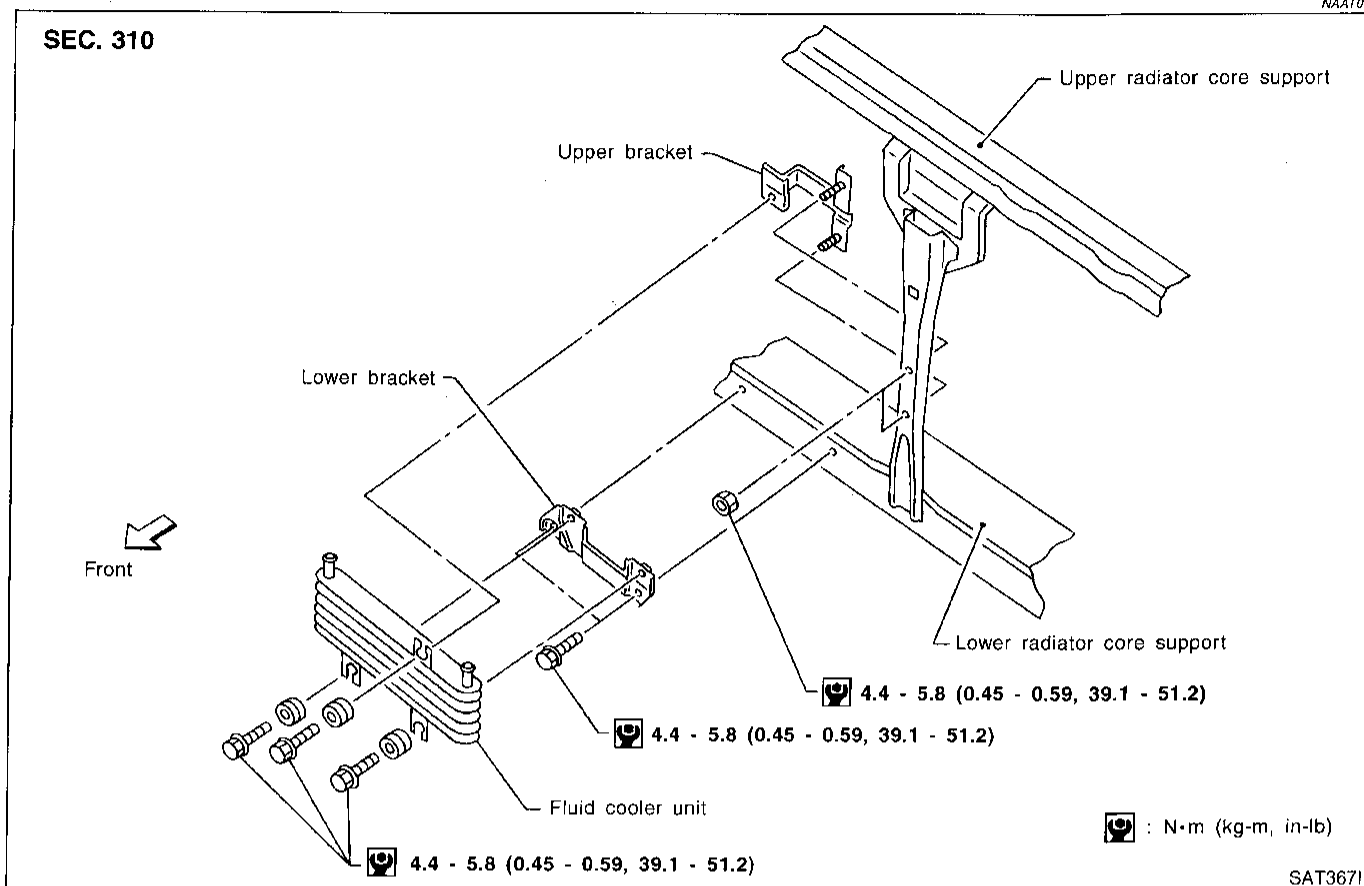

Removal and Installation

NAAT0159

1. Remove front radiator grill. Refer to BT section ("BODY END").
 2. Disconnect fluid hoses from fluid cooler unit.
 3. Remove fluid cooler unit.
 4. Remove fluid cooler bracket.
 5. Remove clips securing fluid hose (cooler unit to radiator) and loosen hose clamps, then remove the fluid hose.
 6. Loosen clamps securing fluid hose (A/T assembly to fluid cooler), then remove the fluid hose.
 7. Remove bolts securing fluid cooler tube bracket.
 8. Remove fluid hose with bracket.
- Reverse the removal procedure to install the A/T fluid cooler unit. Refer to the component drawing and specified tightening torque.
 - Check A/T fluid level and refill if necessary. Refer to MA section ("CHASSIS AND BODY MAINTENANCE").

SERVICE DATA AND SPECIFICATIONS (SDS)

General Specifications

General Specifications

NAAT0160

Applied model		VG33E engine	
		2WD	4WD
Automatic transmission model		RE4R01A	
Transmission model code number		44X82	44X20
Stall torque ratio		2.0 : 1	
Transmission gear ratio	1st	2.785	
	2nd	1.545	
	Top	1.000	
	OD	0.694	
	Reverse	2.272	
Recommended oil		Nissan Matic "D" (Continental U.S. and Alaska) or Genuine Nissan Automatic Transmission Fluid (Canada)*1	
Oil capacity		8.3ℓ (8-3/4 US qt, 7-1/4 Imp qt)	8.5ℓ (9 US qt, 7-1/2 Imp qt)

*1: Refer to MA section ("Fluids and Lubricants", "RECOMMENDED FLUIDS AND LUBRICANTS").

Shift Schedule

VEHICLE SPEED WHEN SHIFTING GEARS THROTTLE POSITION

NAAT0176

NAAT0178S01

Throttle position	Vehicle speed km/h (MPH)						
	D ₁ →D ₂	D ₂ →D ₃	D ₃ →D ₄	D ₄ →D ₃	D ₃ →D ₂	D ₂ →D ₁	1 ₂ →1 ₁
Full throttle	48 - 52 (30 - 32)	93 - 101 (58 - 63)	148 - 158 (92 - 98)	143 - 153 (89 - 95)	88 - 96 (55 - 60)	43 - 47 (27 - 29)	44 - 48 (27 - 30)
Half throttle	35 - 39 (22 - 24)	69 - 75 (43 - 47)	134 - 142 (83 - 88)	59 - 67 (37 - 42)	32 - 38 (20 - 24)	10 - 14 (6 - 9)	44 - 48 (27 - 30)

VEHICLE SPEED WHEN PERFORMING AND RELEASING LOCK-UP

2WD, 4WD (Final gear ratio: 4.363) and 4WD (Final gear ratio: 4.636)

NAAT0178S02

Throttle position	Overdrive control switch [Shift position]	Vehicle speed km/h (MPH)	
		Lock-up "ON"	Lock-up "OFF"
Full throttle	ON [D ₄]	149 - 157 (93 - 98)	144 - 152 (89 - 94)
	OFF [D ₃]	93 - 101 (58 - 63)	88 - 96 (55 - 60)
Half throttle	ON [D ₄]	141 - 149 (88 - 93)	85 - 93 (53 - 58)
	OFF [D ₃]	74 - 82 (46 - 51)	71 - 79 (44 - 49)

Stall Revolution

NAAT0163

Stall revolution rpm	2,440 - 2,640
----------------------	---------------

Line Pressure

NAAT0164

Engine speed rpm	Line pressure kPa (kg/cm ² , psi)	
	D, 2 and 1 positions	R position
Idle	422 - 461 (4.3 - 4.7, 61 - 67)	667 - 706 (6.8 - 7.2, 97 - 102)
Stall	1,020 - 1,098 (10.4 - 11.2, 148 - 159)	1,422 - 1,500 (14.5 - 15.3, 206 - 218)

SERVICE DATA AND SPECIFICATIONS (SDS)

Return Springs

Return Springs

NAAT0165
Unit: mm (in)

Parts		Item			
		Part No.	Free length	Outer diameter	
Control valve	Upper body	Torque converter relief valve spring	31742-41X23	38.0 (1.496)	9.0 (0.354)
		Pressure regulator valve spring	31742-41X24	44.02 (1.7331)	14.0 (0.551)
		Pressure modifier valve spring	31742-41X19	31.95 (1.2579)	6.8 (0.268)
		Accumulator control valve spring	—	—	—
		Shuttle shift valve D spring	31762-41X01	25.0 (0.984)	7.0 (0.276)
		4-2 sequence valve spring	31756-41X00	29.1 (1.146)	6.95 (0.2736)
		Shift valve B spring	31762-41X01	25.0 (0.984)	7.0 (0.276)
		4-2 relay valve spring	31756-41X00	29.1 (1.146)	6.95 (0.2736)
		Shift valve A spring	31762-41X01	25.0 (0.984)	7.0 (0.276)
		Overrun clutch control valve spring	31762-41X03	23.6 (0.929)	7.0 (0.276)
		Overrun clutch reducing valve spring	31742-41X20	32.5 (1.280)	7.0 (0.276)
		Shuttle shift valve S spring	31762-41X04	51.0 (2.008)	5.65 (0.2224)
		Pilot valve spring	31742-41X13	25.7 (1.012)	9.1 (0.358)
		Lock-up control valve spring	31742-41X22	18.5 (0.728)	13.0 (0.512)
	Lower body	Modifier accumulator valve spring	31742-27X70	31.4 (1.236)	9.8 (0.386)
		1st reducing valve spring	31756-41X05	25.4 (1.000)	6.75 (0.2657)
		3-2 timing valve spring	31742-41X06	23.0 (0.906)	6.7 (0.264)
Servo charger valve spring		31742-41X06	23.0 (0.906)	6.7 (0.264)	
Reverse clutch	16 pcs	31521-41X02 (Assembly)	19.7 (0.7756)	11.6 (0.457)	
High clutch	10 pcs	31521-41X03 (Assembly)	24.2 (0.9528)	11.6 (0.457)	
Forward clutch (Overrun clutch)	20 pcs	31521-41X00 (Assembly)	35.77 (1.4083)	9.7 (0.382)	
Low & reverse brake	18 pcs	31655-41X00 (Assembly)	22.3 (0.878)	11.2 (0.441)	
Band servo	Spring A	31605-41X05	45.6 (1.795)	34.3 (1.350)	
	Spring B	31605-41X00	53.8 (2.118)	40.3 (1.587)	
	Spring C	31605-41X01	29.7 (1.169)	27.6 (1.087)	
Accumulator	Accumulator A	31605-41X02	43.0 (1.693)	—	
	Accumulator B	31605-41X10	66.0 (2.598)	—	
	Accumulator C	31605-41X09	45.0 (1.772)	—	
	Accumulator D	31605-41X06	58.4 (2.299)	—	

SERVICE DATA AND SPECIFICATIONS (SDS)

Accumulator O-ring

Accumulator O-ring

NAAT0166

Accumulator	Diameter mm (in)			
	A	B	C	D
Small diameter end	29 (1.14)	32 (1.26)	45 (1.77)	29 (1.14)
Large diameter end	45 (1.77)	50 (1.97)	50 (1.97)	45 (1.77)

Clutches and Brakes

NAAT0167

REVERSE CLUTCH

NAAT0167S01

Code number		44X82	44X20
Number of drive plates		2	
Number of driven plates		2	
Thickness of drive plate mm (in)	Standard	1.90 - 2.05 (0.0748 - 0.0807)	
	Wear limit	1.80 (0.0709)	
Clearance mm (in)	Standard	0.5 - 0.8 (0.020 - 0.031)	
	Allowable limit	1.2 (0.047)	
Thickness of retaining plate	Thickness mm (in)		Part number
	4.8 (0.189)		31537-42X02
	5.0 (0.197)		31537-42X03
	5.2 (0.205)		31537-42X04
	5.4 (0.213)		31537-42X05
	5.6 (0.220)		31537-42X06

HIGH CLUTCH

NAAT016/S02

Code number		44X82	44X20
Number of drive plates		5	
Number of driven plates		5	
Thickness of drive plate mm (in)	Standard	1.52 - 1.67 (0.0598 - 0.0657)	
	Wear limit	1.40 (0.0551)	
Clearance mm (in)	Standard	1.8 - 2.2 (0.071 - 0.087)	
	Allowable limit	2.8 (0.110)	
Thickness of retaining plate	Thickness mm (in)		Part number
	3.4 (0.134)		31537-41X71
	3.6 (0.142)		31537-41X61
	3.8 (0.150)		31537-41X62
	4.0 (0.157)		31537-41X63
	4.2 (0.165)		31537-41X64
	4.4 (0.173)		31537-41X65
	4.6 (0.181)		31537-41X66
4.8 (0.189)		31537-41X67	

SERVICE DATA AND SPECIFICATIONS (SDS)

Clutches and Brakes (Cont'd)

FORWARD CLUTCH

NAAT0167S03

Code number		44X82	44X20
Number of drive plates		6	
Number of driven plates		6	
Thickness of drive plate mm (in)	Standard	1.52 - 1.67 (0.0598 - 0.0657)	
	Wear limit	1.40 (0.0551)	
Clearance mm (in)	Standard	0.35 - 0.75 (0.0138 - 0.0295)	
	Allowable limit	1.85 (0.0728)	
Thickness of retaining plate		Thickness mm (in)	Part number
		8.0 (0.315)	31537-41X00
		8.1 (0.319)	31537-42X60
		8.2 (0.323)	31537-41X01
		8.3 (0.327)	31537-42X61
		8.4 (0.331)	31537-41X02
		8.5 (0.335)	31537-42X62
		8.6 (0.339)	31537-41X03
		8.7 (0.343)	31537-42X63
		8.8 (0.346)	31537-41X04
		8.9 (0.350)	31537-42X64
		9.0 (0.354)	31537-41X05
9.1 (0.358)	31537-42X65		
9.2 (0.362)	31537-41X06		

OVERRUN CLUTCH

NAAT0167S04

Code number		44X82	44X20
Number of drive plates		3	
Number of driven plates		5	
Thickness of drive plate mm (in)	Standard	1.90 - 2.05 (0.0748 - 0.0807)	
	Wear limit	1.80 (0.0709)	
Clearance mm (in)	Standard	1.0 - 1.4 (0.039 - 0.055)	
	Allowable limit	2.0 (0.079)	
Thickness of retaining plate		Thickness mm (in)	Part number
		4.2 (0.165)	31537-41X80
		4.4 (0.173)	31537-41X81
		4.6 (0.181)	31537-41X82
		4.8 (0.189)	31537-41X83
		5.0 (0.197)	31537-41X84

SERVICE DATA AND SPECIFICATIONS (SDS)

Clutches and Brakes (Cont'd)

LOW & REVERSE BRAKE

NAAT0167S05

Code number	44X82	44X20
Number of drive plates	7	
Number of driven plates	7	
Thickness of drive plate mm (in)	Standard	1.52 - 1.67 (0.0598 - 0.0657)
	Wear limit	1.40 (0.0551)
Clearance mm (in)	Standard	0.8 - 1.1 (0.031 - 0.043)
	Allowable limit	2.3 (0.091)
Thickness of retaining plate	Thickness mm (in)	Part number
	6.6 (0.260)	31667-41X17
	6.8 (0.268)	31667-41X11
	7.0 (0.276)	31667-41X12
	7.2 (0.283)	31667-41X13
	7.4 (0.291)	31667-41X14
	7.6 (0.299)	31667-41X07
	7.8 (0.307)	31667-41X08
	8.0 (0.315)	31667-41X00
	8.2 (0.323)	31667-41X01
	8.4 (0.331)	31667-41X02

BRAKE BAND

NAAT0167S06

Anchor end bolt tightening torque	4 - 6 N·m (0.4 - 0.6 kg-m, 35 - 52 in-lb)
Number of returning revolution for anchor end bolt	2.5

Oil Pump and Low One-way Clutch

NAAT0168
Unit: mm (in)

Oil pump clearance	Cam ring — oil pump housing	Standard	0.01 - 0.024 (0.0004 - 0.0009)
	Rotor, vanes and control piston — oil pump housing	Standard	0.03 - 0.044 (0.0012 - 0.0017)
Seal ring clearance		Standard	0.10 - 0.25 (0.0039 - 0.0098)
		Allowable limit	0.25 (0.0098)

Total End Play

NAAT0169

Total end play "T ₁ "	0.25 - 0.55 mm (0.0098 - 0.0217 in)	
Thickness of oil pump cover bearing race	Thickness mm (in)	Part number
	0.8 (0.031)	31435-41X01
	1.0 (0.039)	31435-41X02
	1.2 (0.047)	31435-41X03
	1.4 (0.055)	31435-41X04
	1.6 (0.063)	31435-41X05
	1.8 (0.071)	31435-41X06
	2.0 (0.079)	31435-41X07

SERVICE DATA AND SPECIFICATIONS (SDS)

Reverse Clutch Drum End Play

Reverse Clutch Drum End Play

NAAT0170

Reverse clutch drum end play "T ₂ "	0.55 - 0.90 mm (0.0217 - 0.0354 in)	
Thickness of oil pump thrust washer	Thickness mm (in)	Part number
	0.9 (0.035)	31528-21X01
	1.1 (0.043)	31528-21X02
	1.3 (0.051)	31528-21X03
	1.5 (0.059)	31528-21X04
	1.7 (0.067)	31528-21X05
	1.9 (0.075)	31528-21X06

Removal and Installation

NAAT0171

Manual control linkage	Number of returning revolutions for lock nut	2
	Lock nut tightening torque	4.4 - 5.9 N·m (0.45 - 0.60 kg-m, 39.1 - 52.1 in-lb)
Distance between end of clutch housing and torque converter		26.0 mm (1.024 in) or more