

MANUAL TRANSMISSION

SECTION **MT**

CONTENTS

PREPARATION	2	
Special Service Tools	2	
Commercial Service Tool.....	4	
NOISE, VIBRATION AND HARSHNESS (NVH)		
TROUBLESHOOTING	5	
NVH Troubleshooting Chart.....	5	
MANUAL TRANSMISSION.....	5	
ON-VEHICLE SERVICE	6	
Replacing Rear Oil Seal — 2WD Model.....	6	
REMOVAL.....	6	
INSTALLATION.....	6	
Position Switch Check.....	6	
DESCRIPTION	7	
Cross-sectional View — 2WD Model	7	
Cross-sectional View — 4WD Model	8	
REMOVAL AND INSTALLATION	9	
Removal.....	9	
2WD MODEL.....	9	
4WD MODEL.....	10	
Installation.....	11	
OVERHAUL	12	
Case Components	12	
Gear Components	13	
Shift Control Components	15	
DISASSEMBLY	16	
Case Components.....	16	
DISASSEMBLY.....	16	
Shift Control Components	17	
DISASSEMBLY.....	17	
Gear Components	18	
DISASSEMBLY.....	18	
INSPECTION.....	22	
Shift Control Components	22	
INSPECTION.....	22	
Gear Components	22	
INSPECTION.....	22	
ASSEMBLY	24	
Gear Components	24	
ASSEMBLY.....	24	
Shift Control Components	32	
ASSEMBLY.....	32	
Case Components.....	33	
ASSEMBLY.....	33	
SERVICE DATA AND SPECIFICATIONS (SDS)	35	
General Specifications.....	35	
Gear End Play	35	
Clearance Between Baulk Ring and Gear	35	
2ND AND 3RD BAULK RING.....	36	
Distance Between Rear Surface of Reverse Cone and Reverse Baulk Ring.....	36	
Available Snap Ring	36	
MAIN DRIVE GEAR SNAP RING	36	
MAINSHAFT FRONT SNAP RING.....	36	
COUNTER GEAR REAR SNAP RING	37	
Available C-ring	37	
MAINSHAFT C-RING	37	
Available Shim and Washer	37	
TABLE FOR SELECTING PROPER COUNTER GEAR FRONT BEARING THRUST WASHER	37	
REVERSE IDLER REAR THRUST WASHER	37	

GI
MA
EM
LC
EC
FE
CL
MT
AT
TF
PD
AX
SU
BR
ST
RS
BT
HA
SC
EL
IDX

PREPARATION

Special Service Tools

Special Service Tools

NAMT0001

The actual shapes of Kent-Moore tools may differ from those of special service tools illustrated here.

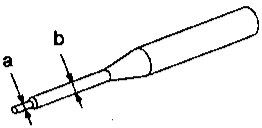
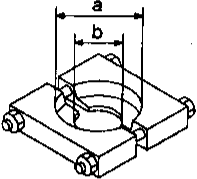
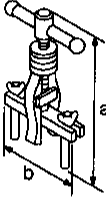
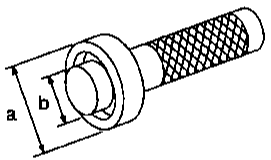
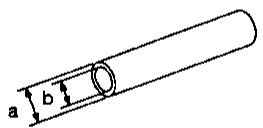
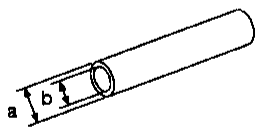
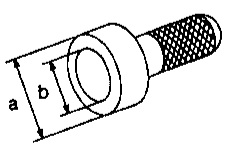
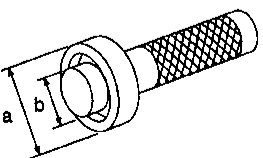
Tool number (Kent-Moore No.) Tool name	Description
ST23540000 (J25689-A) Pin punch	 <p>Removing and installing retaining pin a: 2.3 mm (0.091 in) dia. b: 4 mm (0.16 in) dia.</p> <p style="text-align: center;">NT442</p>
ST30031000 (J22912-01) Puller	 <p>Removing 1st & 2nd synchronizer assembly Removing counter gear rear thrust bearing Removing main drive bearing a: 90 mm (3.54 in) dia. b: 50 mm (1.97 in) dia.</p> <p style="text-align: center;">NT411</p>
ST33290001 (J25810-A) Puller	 <p>Removing rear oil seal a: 250 mm (9.84 in) b: 160 mm (6.30 in)</p> <p style="text-align: center;">NT414</p>
ST33230000 (—) Drift	 <p>Removing mainshaft and counter gear a: 51 mm (2.01 in) dia. b: 28.5 mm (1.122 in) dia.</p> <p style="text-align: center;">NT084</p>
ST22350000 (J25678-01) Drift	 <p>Removing counter gear front bearing (Use with KV38100300) a: 34 mm (1.34 in) dia. b: 28 mm (1.10 in) dia.</p> <p style="text-align: center;">NT065</p>
KV38100300 (J25523) Drift	 <p>Removing counter gear front bearing (Use with ST22350000) Installing counter gear rear bearing a: 54 mm (2.13 in) dia. b: 32 mm (1.26 in) dia.</p> <p style="text-align: center;">NT065</p>
ST30720000 1 (J34286) 2 (J34331) Drift	 <p>1 Removing mainshaft front bearing 2 Installing mainshaft front bearing a: 77 mm (3.03 in) dia. b: 55.5 mm (2.185 in) dia.</p> <p style="text-align: center;">NT115</p>
ST33210000 1 (J25523) 2 (J25803-01) Drift	 <p>1 Installing counter gear front bearing 2 Installing front cover oil seal a: 44 mm (1.73 in) dia. b: 24.5 mm (0.965 in) dia.</p> <p style="text-align: center;">NT084</p>

PREPARATION

Special Service Tools (Cont'd)

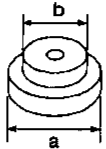
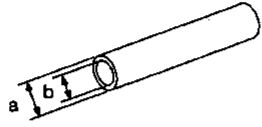
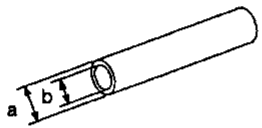
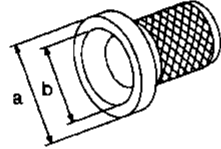
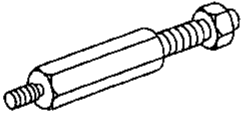
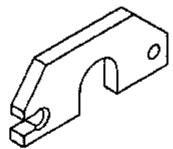
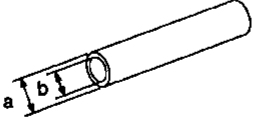
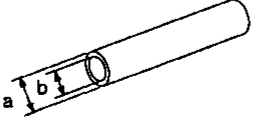
Tool number (Kent-Moore No.) Tool name	Description		
ST30613000 (J25742-3) Drift		Installing main drive gear bearing a: 72 mm (2.83 in) dia. b: 48 mm (1.89 in) dia.	GI MA EM LC
ST37750000 1 (J34286) 2 (J34332) 3 (J34334) 4 (J25679-01) Drift		1 Removing counter gear rear bearing 2 Installing OD gear bushing 2 Removing and installing mainshaft rear bearing (4WD model) 2 Installing reverse cone 3 Installing reverse counter gear 4 Installing counter gear rear end bearing a: 40 mm (1.57 in) dia. b: 31 mm (1.22 in) dia.	EC FE CL
ST22452000 (J34337) Drift		Installing reverse hub Installing mainshaft rear bearing (2WD model) a: 45 mm (1.77 in) dia. b: 36 mm (1.42 in) dia.	MT AT
ST33400001 (J26082) Drift		Installing rear oil seal a: 60 mm (2.36 in) dia. b: 47 mm (1.85 in) dia.	TF PD
(J26349-3) Puller leg		Installing mainshaft and counter gear (Use with J34328)	AX SU
(J34328) Puller		Installing mainshaft and counter gear (Use with J26349-3)	BR ST
(J26092) Drift		Installing sub-gear snap ring a: 44.5 mm (1.752 in) dia. b: 38.5 mm (1.516 in) dia.	RS BT
(J34342) Drift		Installing OD main gear Installing reverse gear bushing a: 44.5 mm (1.752 in) dia. b: 40.5 mm (1.594 in) dia.	HA SC EL

PREPARATION

Special Service Tools (Cont'd)

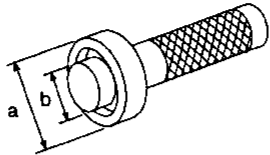
Tool number (Kent-Moore No.) Tool name	Description	
ST33220000 (J25804-01) Drift		Installing mainshaft rear bearing a: 37 mm (1.46 in) dia. b: 22 mm (0.87 in) dia.
	NT084	

Commercial Service Tool

NAMT0002

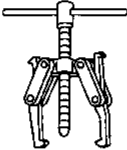
Tool name	Description	
Puller		Removing counter gear rear end bearing Removing mainshaft rear bearing (2WD model) Removing reverse synchronizer hub Removing reverse counter gear
	NT077	

NOISE, VIBRATION AND HARSHNESS (NVH) TROUBLESHOOTING

NVH Troubleshooting Chart

NVH Troubleshooting Chart

NAMT0023S01

Use the chart below to help you find the cause of the problem. The numbers indicate the order of the inspection. If necessary, repair or replace these parts.

MANUAL TRANSMISSION

NAMT0023S0101

Reference page		Refer to MA section ("Checking M/T Oil", "CHASSIS AND BODY MAINTENANCE").													
SUSPECTED PARTS (Possible cause)		OIL (Level low)													
		OIL (Wrong)													
Symptom		Noise	1	2							3	3			
		Oil leakage		3	1	2	2	2							
Symptom		Hard to shift or will not shift		1	1								2	2	
		Jumps out of gear							1	2	2				

GI

MA

EM

LC

EC

FE

CL

MT

AT

TF

PD

AX

SU

BR

ST

RS

BT

HA

SC

EL

IDX

695

ON-VEHICLE SERVICE

Replacing Rear Oil Seal — 2WD Model

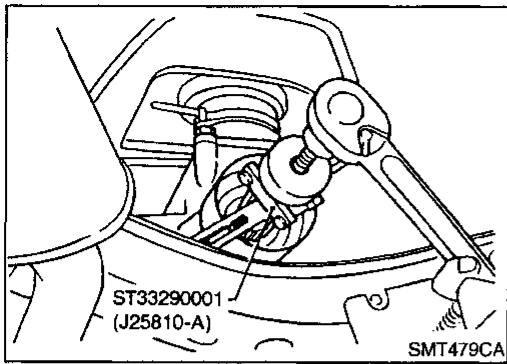

Replacing Rear Oil Seal — 2WD Model REMOVAL

NAMT0003
NAMT0003S01

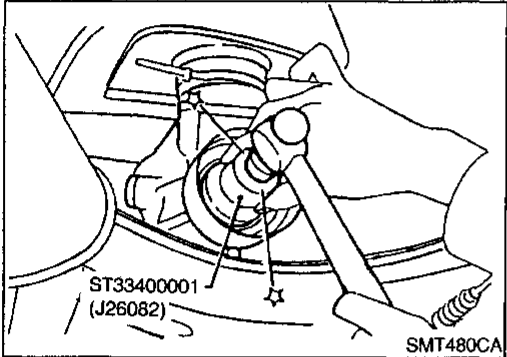

INSTALLATION

NAMT0003S02

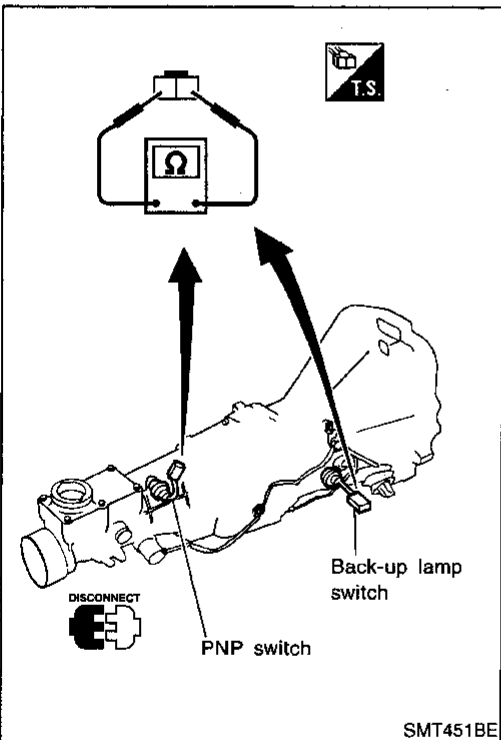

Position Switch Check

NAMT0004

Switch	Gear position	Continuity
Back-up lamp switch	Reverse	Yes
	Except reverse	No
PNP switch	Neutral	Yes
	Except neutral	No

DESCRIPTION

Cross-sectional View — 2WD Model

Cross-sectional View — 2WD Model

NAMT0005S01

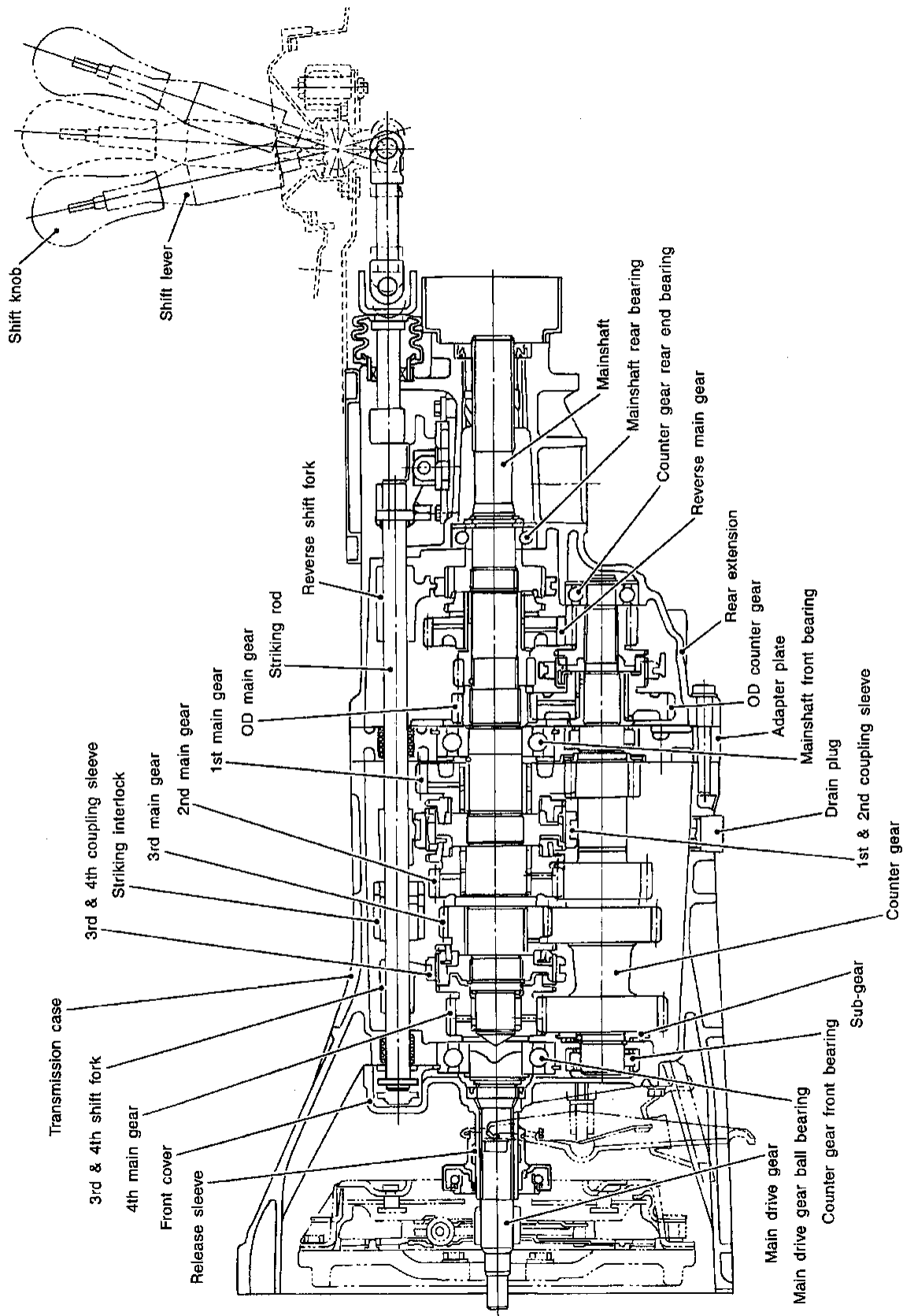

- GI
- MA
- EM
- LC
- EC
- FE
- CL
- MT**
- AT
- TF
- PD
- AX
- SU
- BR
- ST
- RS
- BT
- HA
- SC
- EL

SMT209D

DESCRIPTION

Cross-sectional View — 4WD Model

Cross-sectional View — 4WD Model

NAMT0005S02

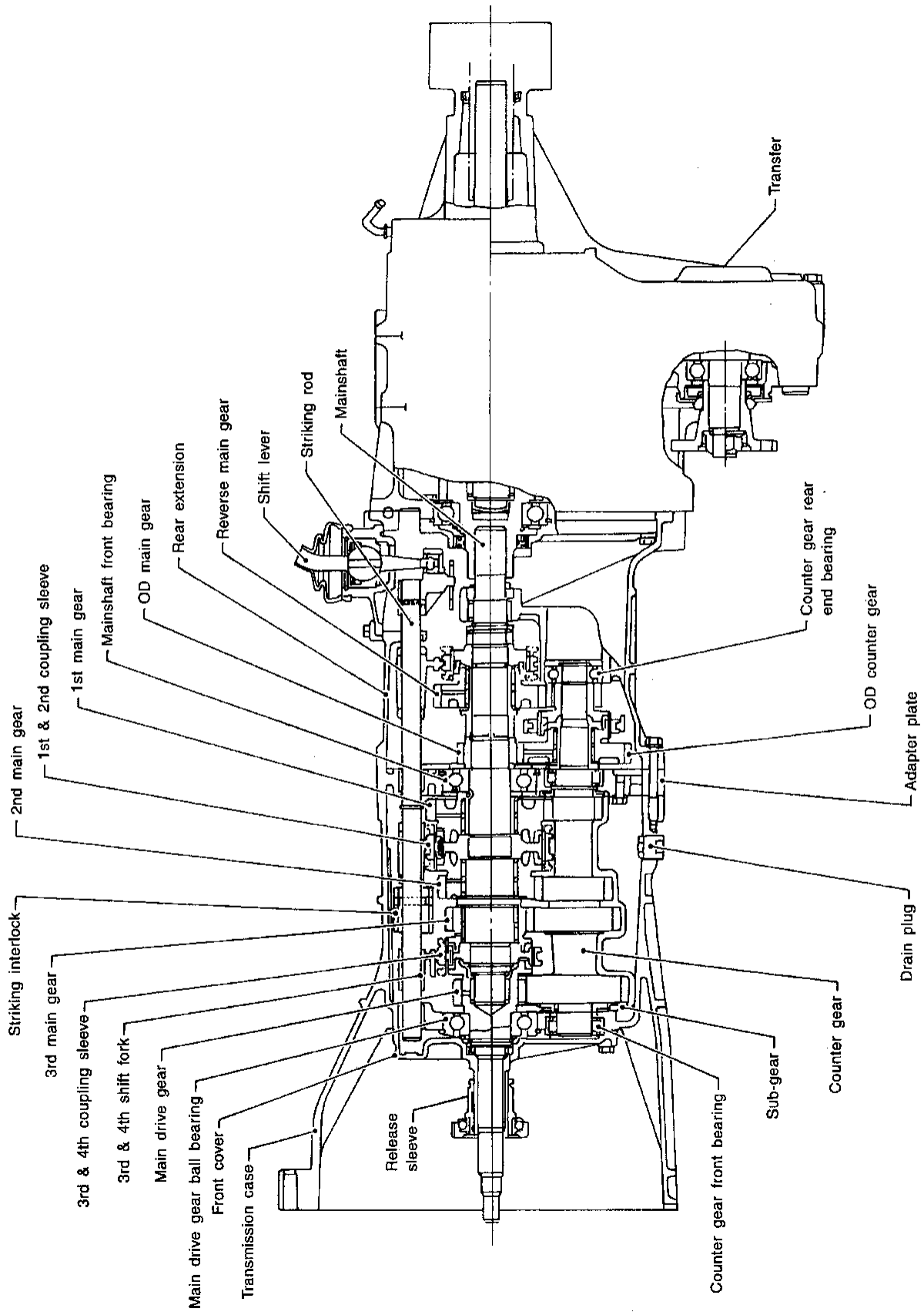

SMT870CA

REMOVAL AND INSTALLATION

Removal

Removal

CAUTION:

When removing the M/T assembly from engine, first remove the crankshaft position sensor (OBD) from the M/T assembly. Be careful not to damage sensor edge.

NAMT0008S01

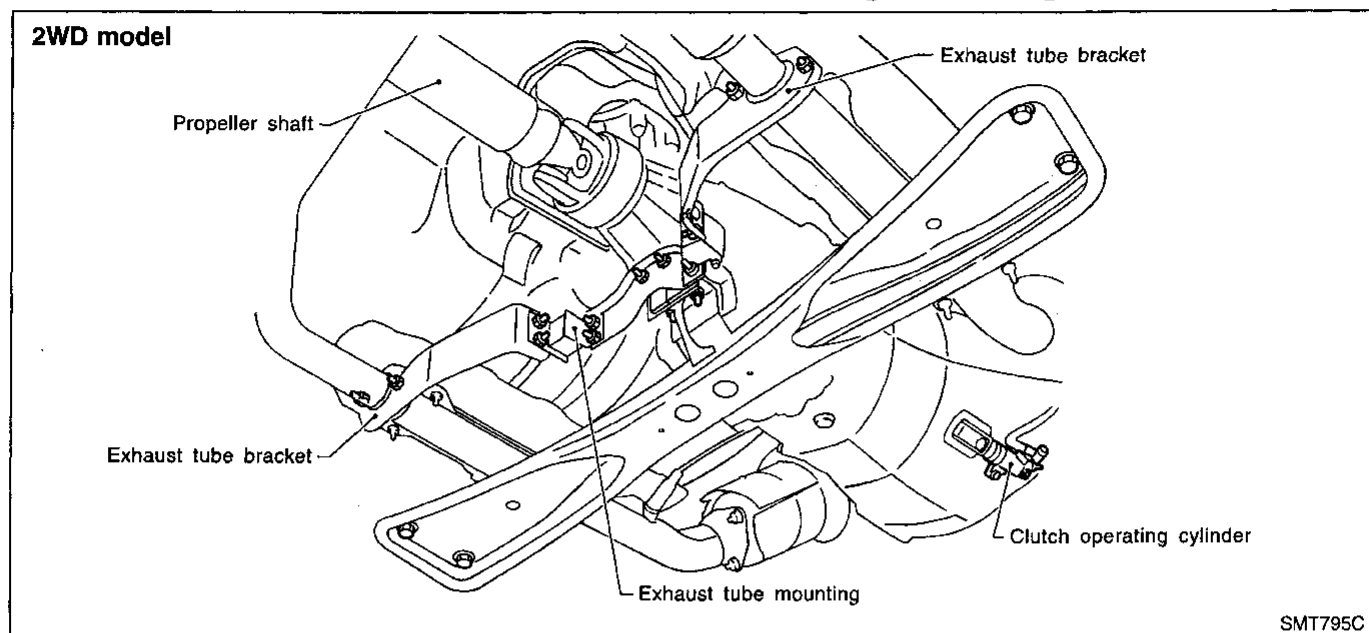

2WD MODEL

NAMT0006S0101

1. Remove battery negative terminal.
2. Remove shift lever with control housing from transmission.
3. Remove crankshaft position sensor (OBD) from upper side of transmission case.
4. Remove clutch operating cylinder from transmission. Tighten clutch operating cylinder to the specified torque. Refer to CL section ("CLUTCH SYSTEM").
5. Disconnect speed sensor, back-up lamp switch, rear heated oxygen sensor and PNP switch harness connectors.
6. Remove starter motor from transmission.
 ⚙️ : 41 - 52 N·m (4.2 - 5.3 kg·m, 30 - 38 ft·lb)
7. Remove propeller shaft. Refer to PD section ("Removal", "PROPELLER SHAFT").
 - Insert plug into rear oil seal after removing propeller shaft.
 - Be careful not to damage spline, sleeve yoke and rear oil seal when removing propeller shaft.
8. Remove gussets from transmission or engine.
9. Remove exhaust tube mounting bracket from transmission. Refer to FE section ("EXHAUST SYSTEM").
10. Support manual transmission with a jack.
11. Remove rear mounting member. Tighten rear mounting member to the specified torque. Refer to EM section ("ENGINE REMOVAL").
12. Lower manual transmission as much as possible.

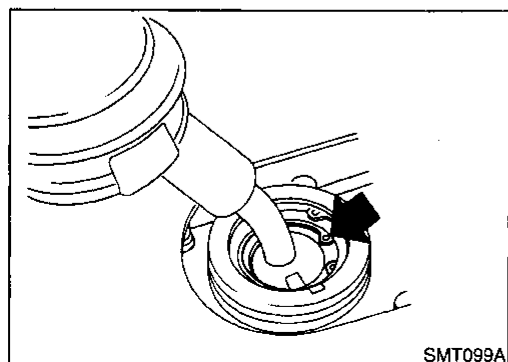

WARNING:

Support manual transmission while removing it.

REMOVAL AND INSTALLATION

Removal (Cont'd)

4WD model

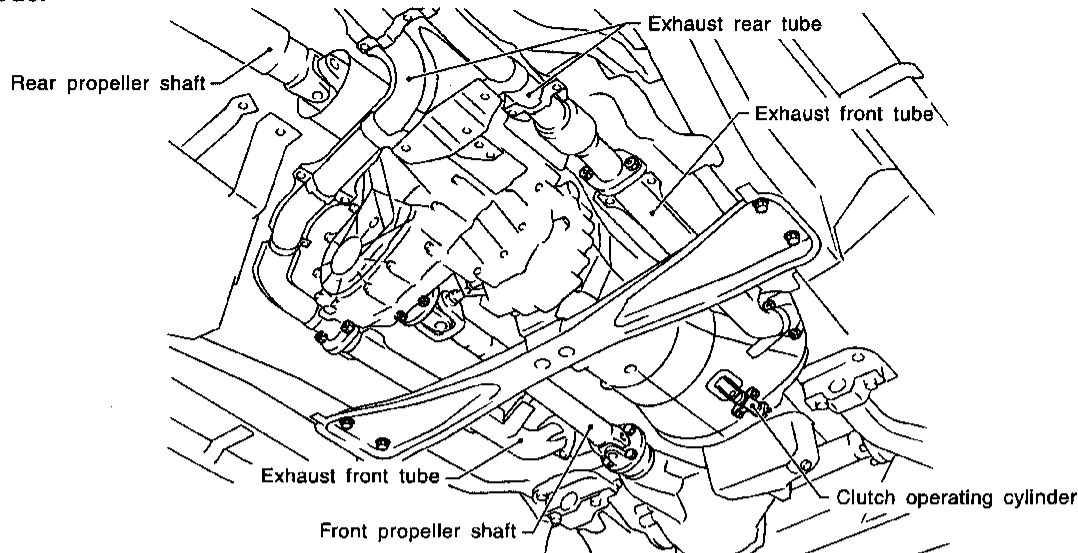

SMT815C

4WD MODEL

NAMT0006S0102

1. Remove battery negative terminal.
2. Remove shift lever from transmission and control lever from transfer.
3. Remove crankshaft position sensor (OBD) from upper side of transmission case.
4. Remove clutch operating cylinder from transmission. Tighten clutch operating cylinder to the specified torque. Refer to CL section ("CLUTCH SYSTEM").
5. Disconnect speed sensor, back-up lamp switch, rear heated oxygen sensor and PNP switch harness connectors.
6. Remove starter motor from transmission.
: 41 - 52 N·m (4.2 - 5.3 kg·m, 30 - 38 ft·lb)
7. Remove front and rear propeller shafts. Refer to PD section ("Removal", "PROPELLER SHAFT").
 - Insert plug into rear oil seal after removing propeller shaft.
 - Be careful not to damage spline, sleeve yoke and rear oil seal when removing propeller shaft.
8. Remove gussets from transmission or engine.
9. Remove exhaust tube mounting bracket from transmission. Refer to FE section ("EXHAUST SYSTEM").
10. Support manual transmission with a jack.
11. Remove rear mounting member. Tighten rear mounting member to the specified torque. Refer to EM section ("ENGINE REMOVAL").
12. Lower manual transmission as much as possible.

WARNING:

Support Manual Transmission together with transfer, while removing it.

REMOVAL AND INSTALLATION

Removal (Cont'd)

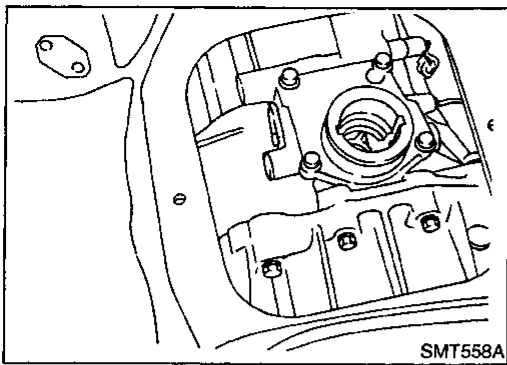

WARNING:
Support Manual Transmission together with transfer, while removing it.

Installation

- Apply sealant as below: — 4WD model

NAM70006S02

Mating surface of engine block and engine rear plate

Mating surface of engine rear plate and transmission case

Unit: mm (in)

SMT796CA

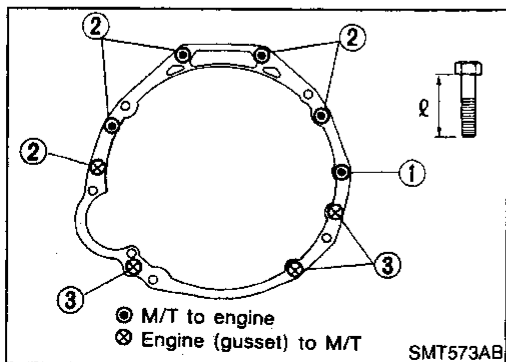

- Tighten bolt securing transmission.

Bolt No.	Tightening torque N·m (kg·m, ft·lb)	ℓ mm (in)
1	39 - 49 (4.0 - 5.0, 29 - 36)	65 (2.56)
2	39 - 49 (4.0 - 5.0, 29 - 36)	58 (2.28)
3	29 - 39 (3.0 - 4.0, 22 - 29)	25 (0.98)
Gusset to engine	29 - 39 (3.0 - 4.0, 22 - 29)	20 (0.79)

GI
MA
EM
LC
EC
FE
CL
MT
AT
TF
PD
AX
SU
BR
ST
RS
BT
HA
SC
EL
IDX
701

OVERHAUL

Case Components

Case Components

NAMT0007S01

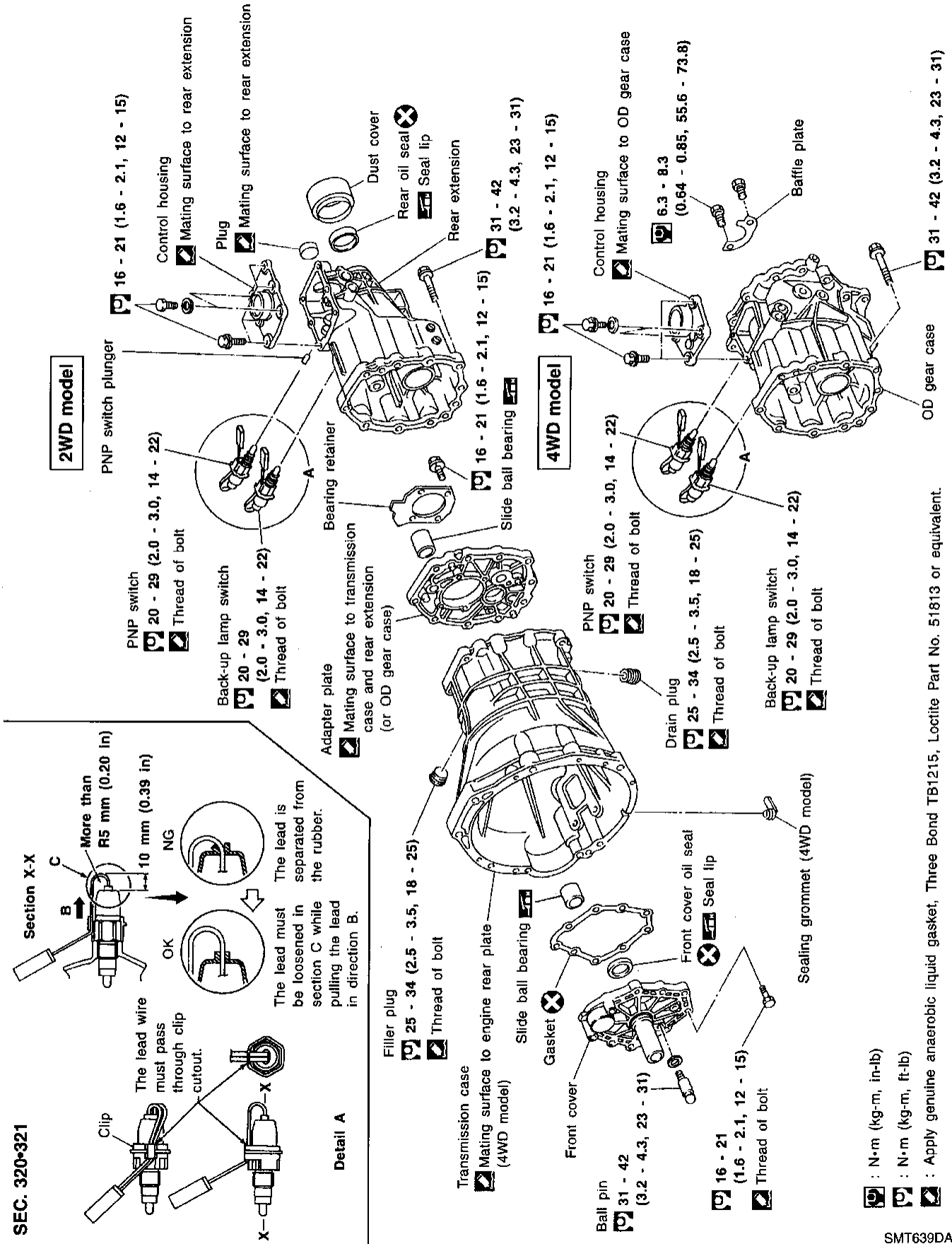

- : N·m (kg·m, in·lb)
- : N·m (kg·m, ft·lb)
- : Apply genuine anaerobic liquid gasket, Three Bond TB1215, Loctite Part No. 51813 or equivalent.

SMT639DA

Gear Components

NAMT0007502

GI

MA

EM

LC

EC

FE

CL

MT

AT

TF

PD

AX

SU

BR

ST

RS

BT

HA

SC

EL

SMT638D

IDX

703

SEC. 322

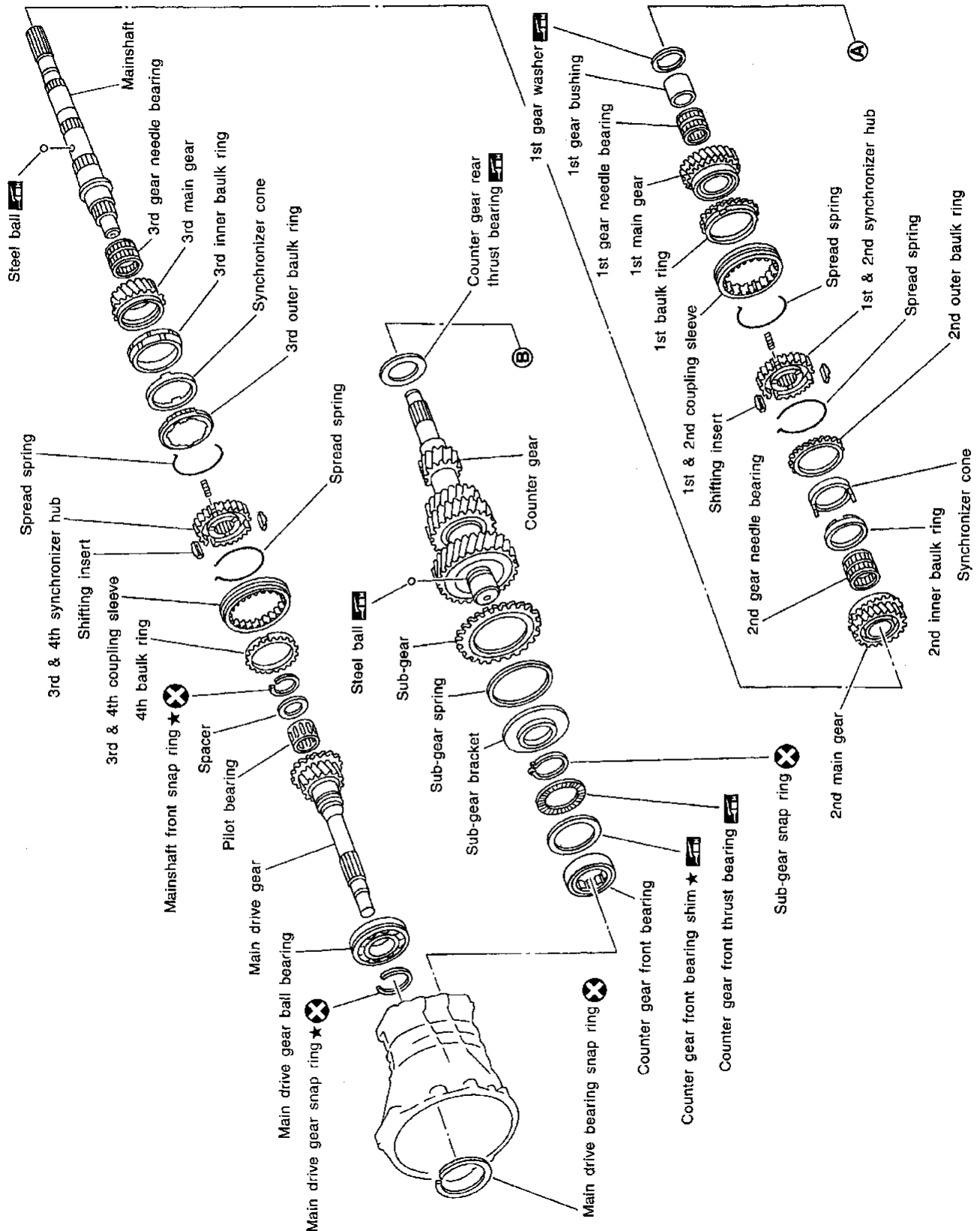

OVERHAUL

Gear Components (Cont'd)

SEC. 322

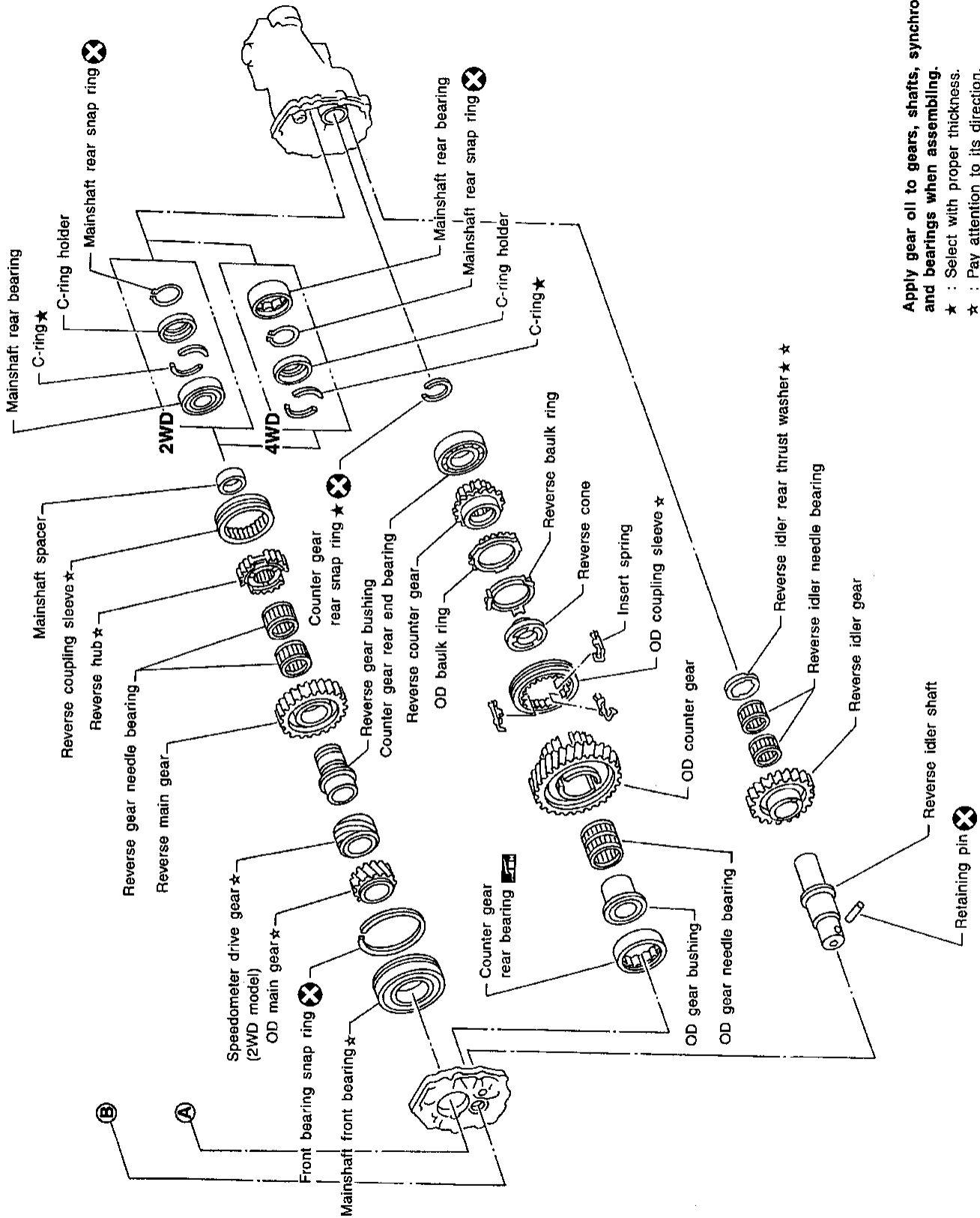

Apply gear oil to gears, shafts, synchronizers and bearings when assembling.

★ : Select with proper thickness.

✳ : Pay attention to its direction.

OVERHAUL

Shift Control Components

NAMT0007503

Shift Control Components

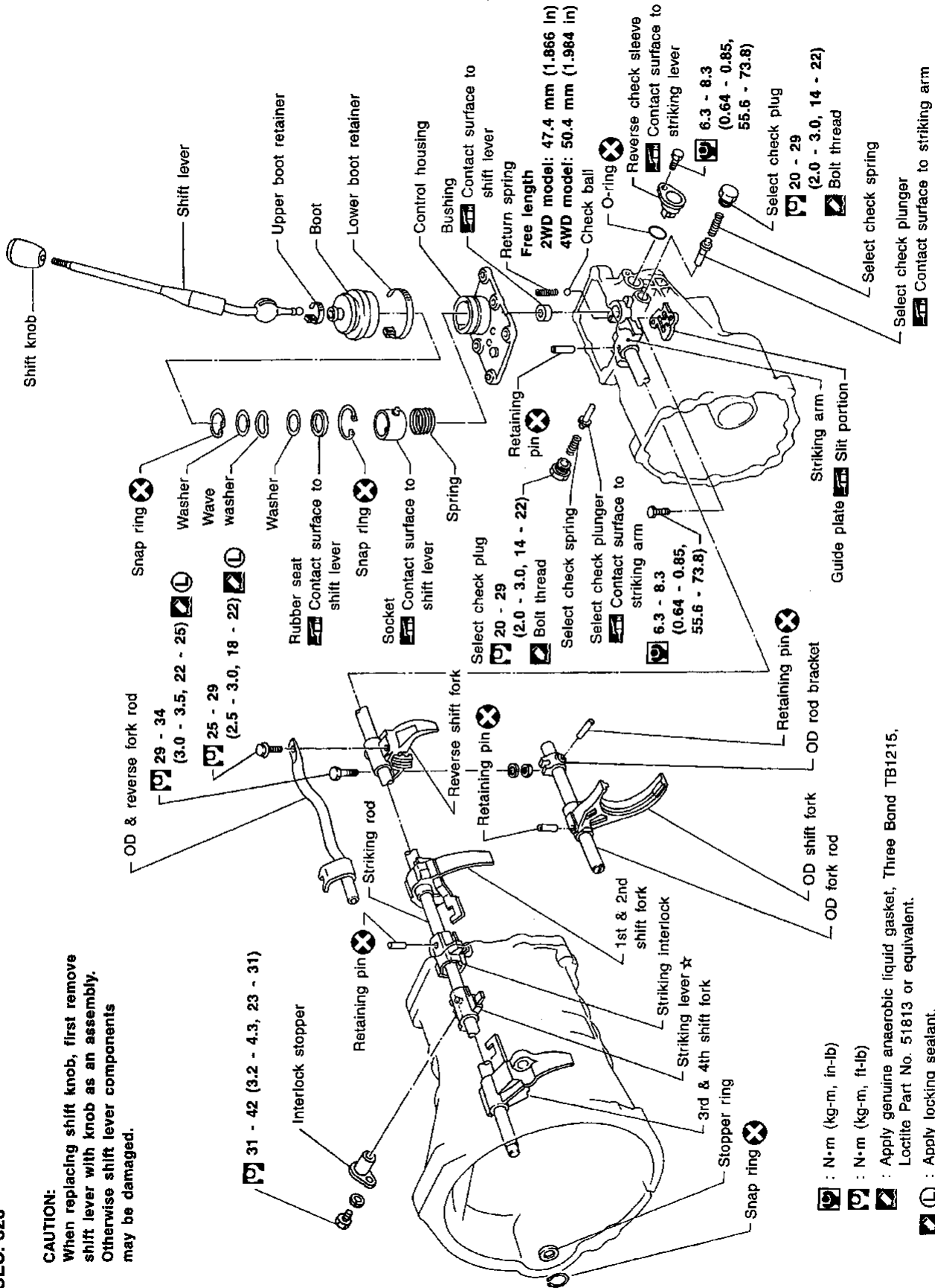

SEC. 328

CAUTION:

When replacing shift knob, first remove shift lever with knob as an assembly. Otherwise shift lever components may be damaged.

Ⓜ : N•m (kg-m, in-lb)

Ⓛ : N•m (kg-m, ft-lb)

Ⓜ : Apply genuine anaerobic liquid gasket, Three Bond TB1215, Loctite Part No. 51813 or equivalent.

Ⓛ : Apply locking sealant.

☆ : Pay attention to its direction.

SMT817D

MT-15

GI
MA
EM
LC
EC
FE
CL
MT
AT
TF
PD
AX
SU
BR
ST
RS
BT
HA
SC
EL
IDX
705

DISASSEMBLY

Case Components

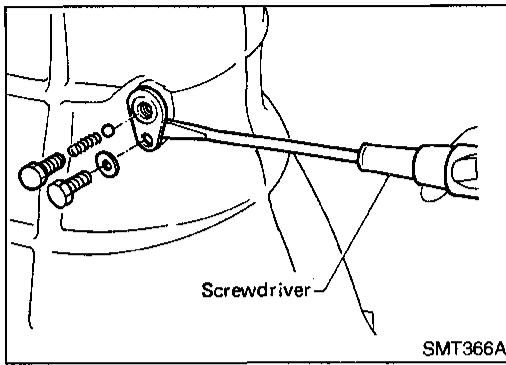

Case Components

DISASSEMBLY

NAMT0008

1. Remove check ball plug, check spring and check ball. Then remove interlock stopper.

- If interlock assembly is removed as a unit, the check ball can fall into transmission case.
- Be careful not to lose check ball.

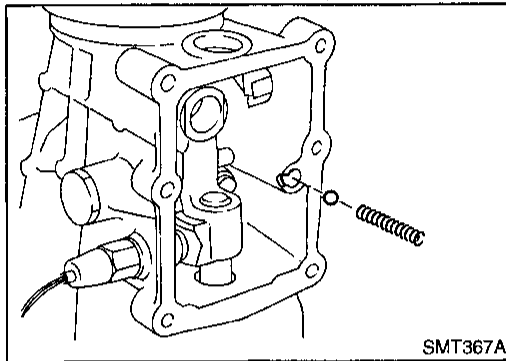

2. Remove control housing, return spring and check ball.

- Be careful not to lose check ball.

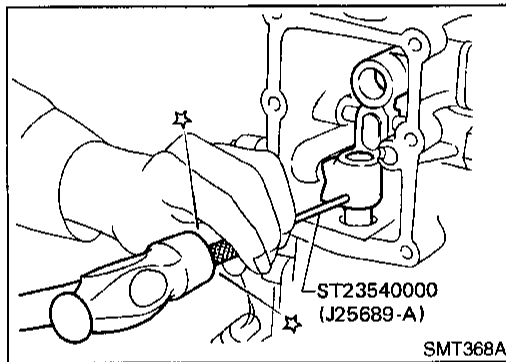

3. Drive out retaining pin from striking arm.

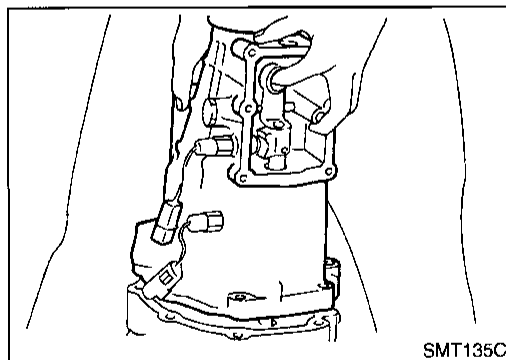

4. Remove rear extension (or OD gear case) together with striking arm by tapping lightly.

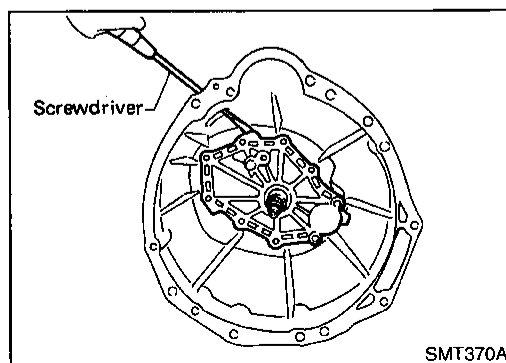

5. Remove front cover and gasket.

DISASSEMBLY

Case Components (Cont'd)

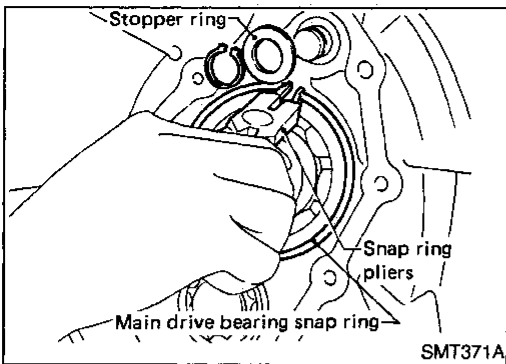

6. Remove stopper ring and main drive bearing snap ring.

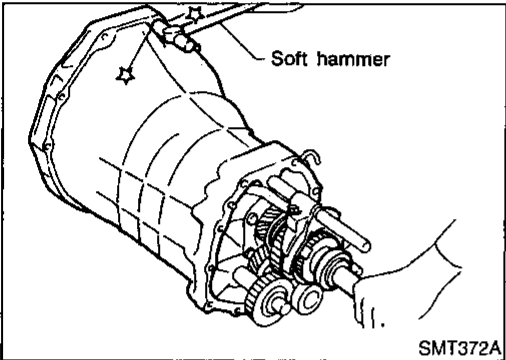

7. Remove transmission case by tapping lightly.

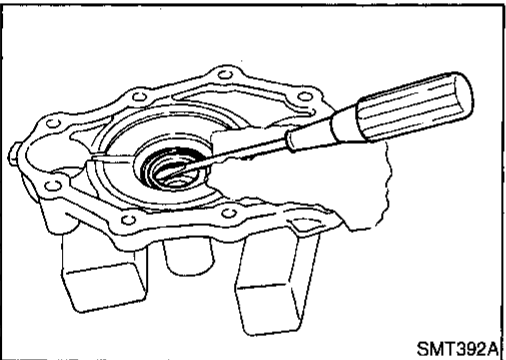

8. Remove front cover oil seal.

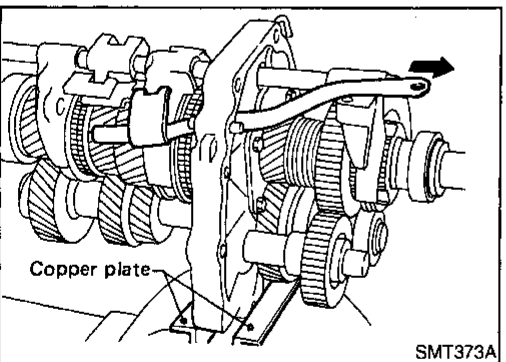

Shift Control Components DISASSEMBLY

1. Mount adapter plate on vise.
2. Remove OD & reverse fork rod.

NAM70009

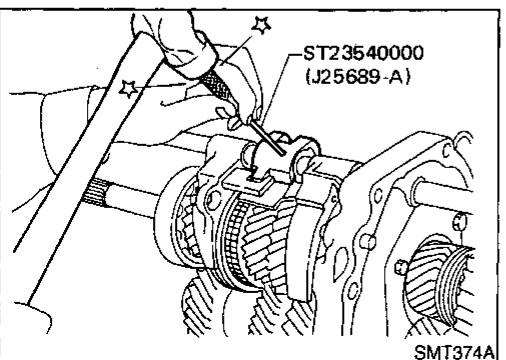

3. Drive out retaining pin from striking lever.
4. While pulling out striking rod, remove striking lever and striking interlock. Then remove 1st & 2nd, 3rd & 4th and reverse shift fork.

GI

MA

EM

LC

EC

FE

CL

MT

AT

TF

PD

AX

SU

BR

ST

RS

BT

HA

SC

EL

IDX

DISASSEMBLY

Shift Control Components (Cont'd)

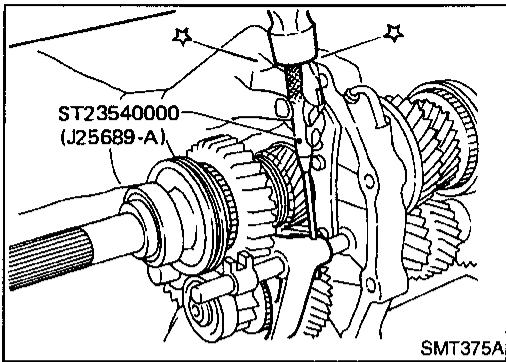

5. Drive out retaining pin from OD shift fork.
6. Pull out OD fork rod and then remove OD shift fork.

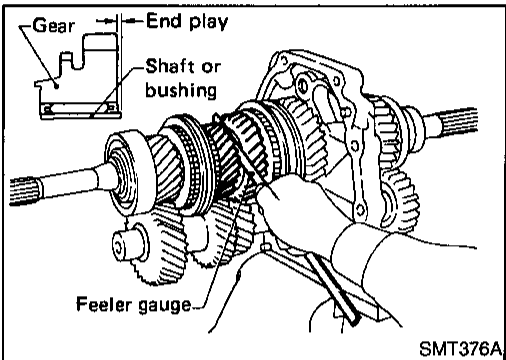

Gear Components DISASSEMBLY

NAMT0010

1. Before removing gears and shafts, measure each gear end play.

Gear end play:

Refer to SDS, MT-35.

- If not within specification, disassemble and check contact surface of gear to hub, washer, bushing, needle bearing and shaft.

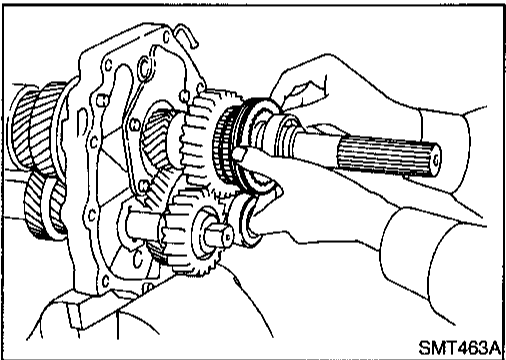

2. Remove rear side components on mainshaft and counter gear.
 - a. Remove reverse coupling sleeve.

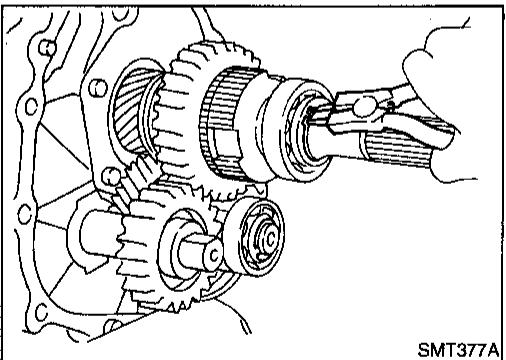

- b. Remove mainshaft rear snap ring and counter gear rear snap ring.
 - c. Remove C-ring holder and mainshaft C-rings from mainshaft. Use punch and hammer to remove C-rings.

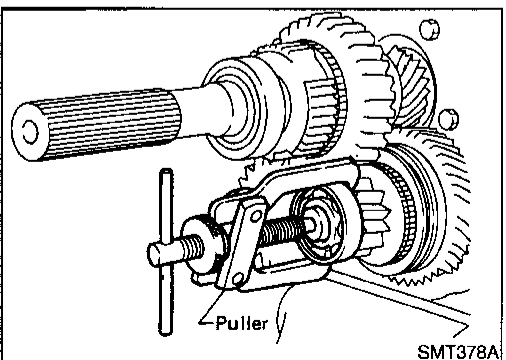

- d. Pull out counter gear rear end bearing.
 - e. Remove reverse idler gear and reverse idler thrust washers.

DISASSEMBLY

Gear Components (Cont'd)

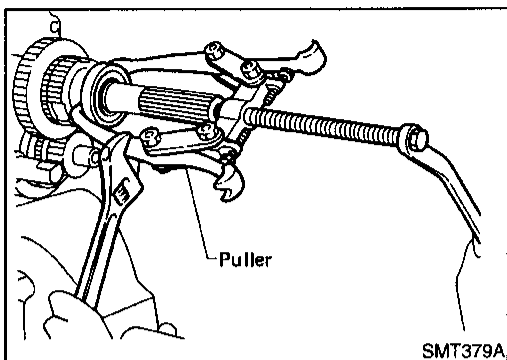

f. Pull out mainshaft rear bearing (2WD model).

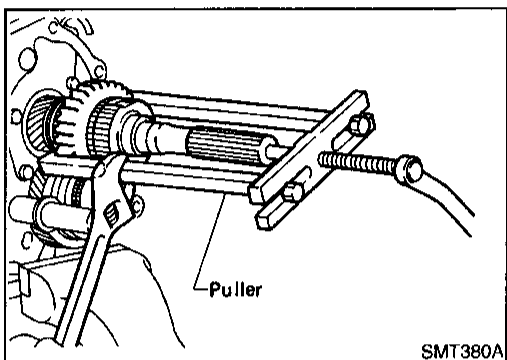

g. Pull out reverse main gear together with mainshaft spacer and reverse synchronizer hub. Then remove reverse gear needle bearings.

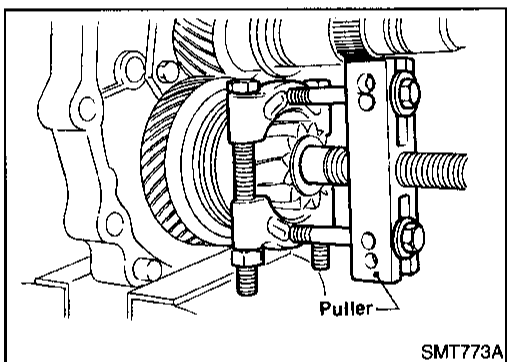

h. Pull out reverse counter gear.

i. Remove OD coupling sleeve together with OD baulk ring, reverse baulk ring and spring inserts.

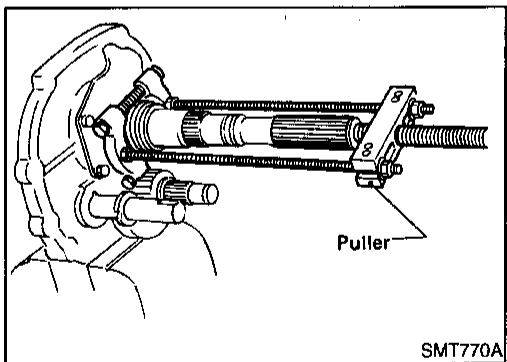

j. Pull out reverse gear bushing.

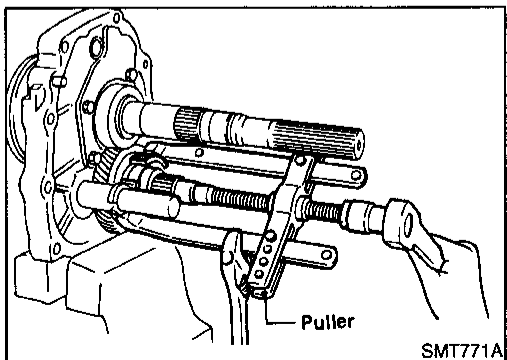

k. Pull out OD counter gear together with reverse cone.

GI

MA

EM

LC

EC

FE

CL

MT

AT

TF

PD

AX

SU

BR

ST

RS

BT

HA

SC

EL

IDX

DISASSEMBLY

Gear Components (Cont'd)

3. Press out mainshaft and counter gear alternately.

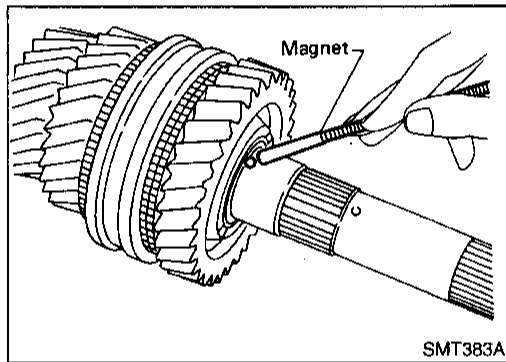
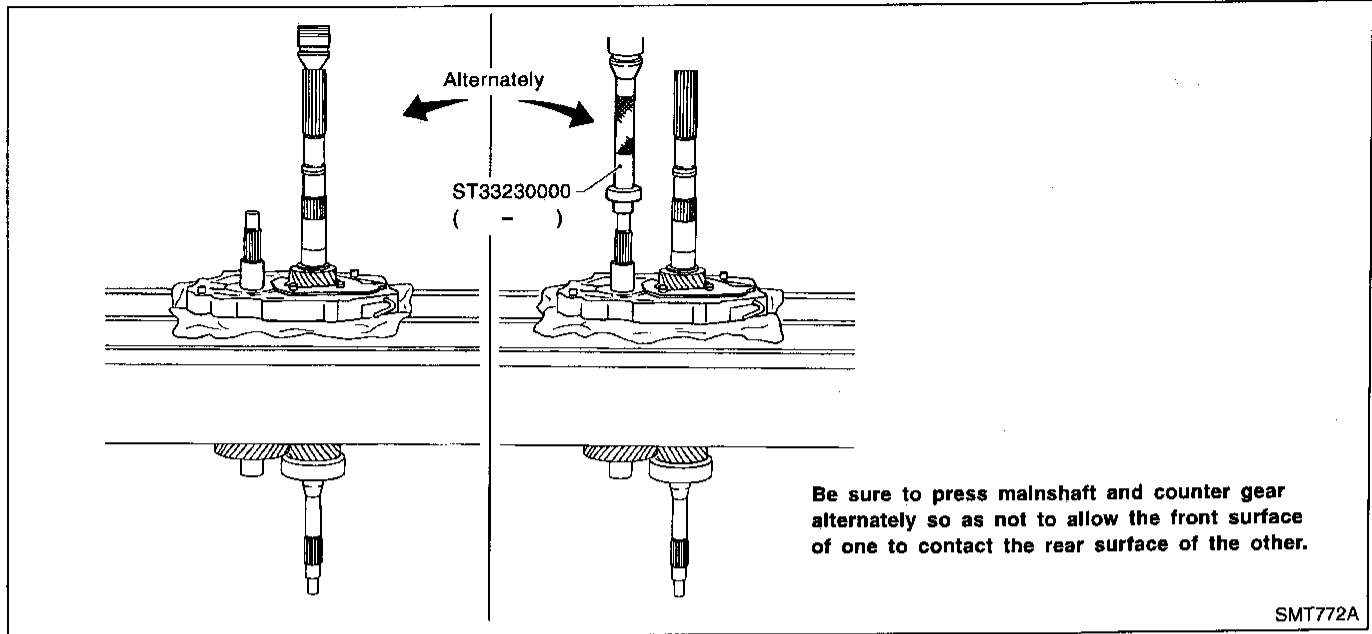

4. Remove front side components on mainshaft.
 - a. Remove 1st gear washer and steel ball.
 - b. Remove 1st main gear and 1st gear needle bearing.
- Be careful not to lose steel ball.

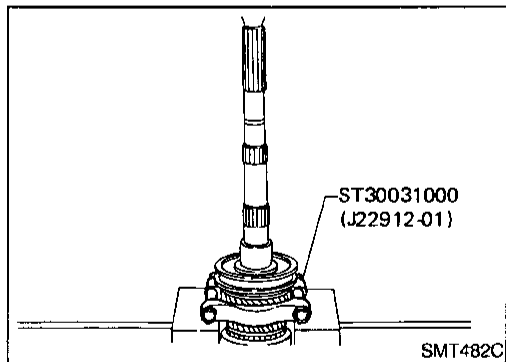

- c. Press out 2nd main gear together with 1st gear bushing and 1st & 2nd synchronizer assembly.
 - d. Remove mainshaft front snap ring.

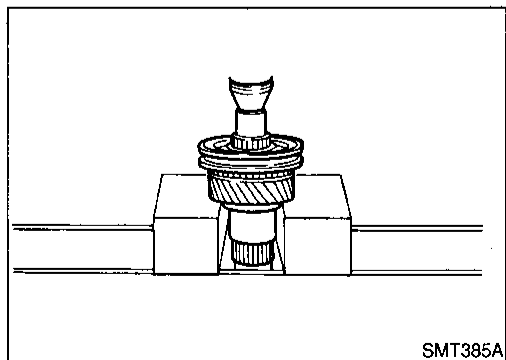

- e. Press out 3rd main gear together with 3rd & 4th synchronizer assembly and 3rd gear needle bearing.

DISASSEMBLY

Gear Components (Cont'd)

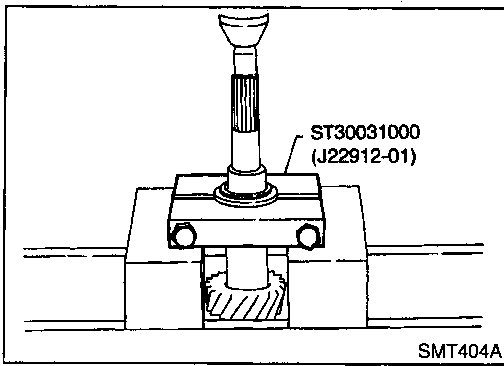

5. Remove front side components on counter gear.
 - a. Remove counter gear rear thrust bearing.

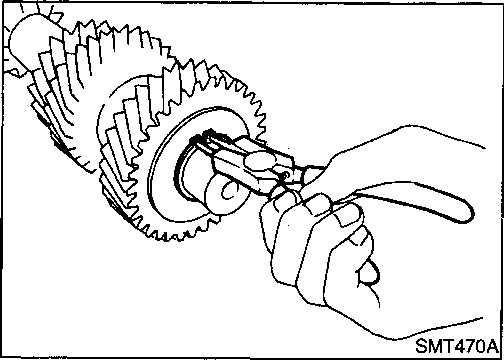

- b. Remove sub-gear components.

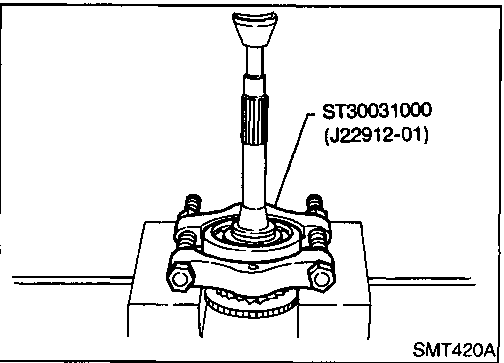

6. Remove main drive gear bearing.
 - a. Remove main drive gear snap ring.
 - b. Press out main drive gear bearing.

7. Remove bearings from case components.

<p>Counter gear front bearing in transmission case</p>	<p>Mainshaft front bearing in adapter plate</p>
<p>Mainshaft rear bearing in OD gear case (4WD model)</p>	<p>Counter gear rear bearing in adapter plate</p>

SMT206D

GI
MA
EM
LC
EC
FE
CL
MT
AT
TF
PD
AX
SU
BR
ST
RS
BT
HA
SC
EL
IDX

INSPECTION

Shift Control Components

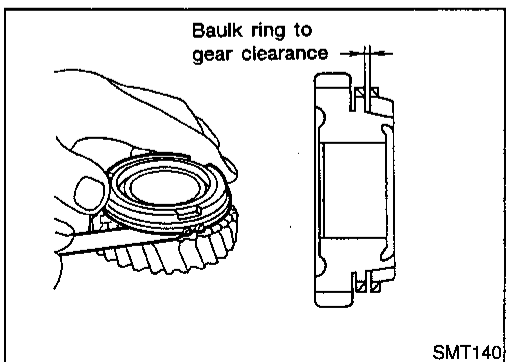
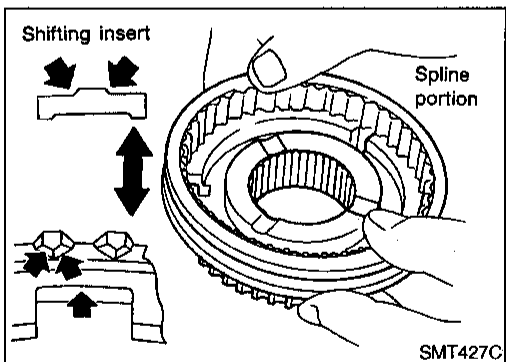
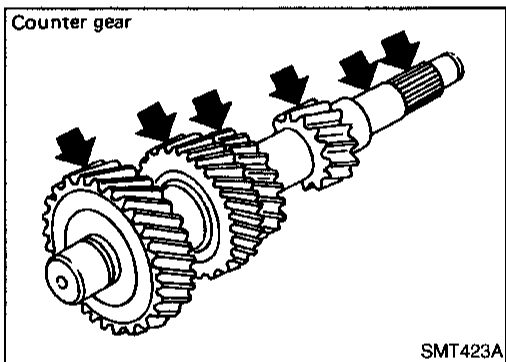
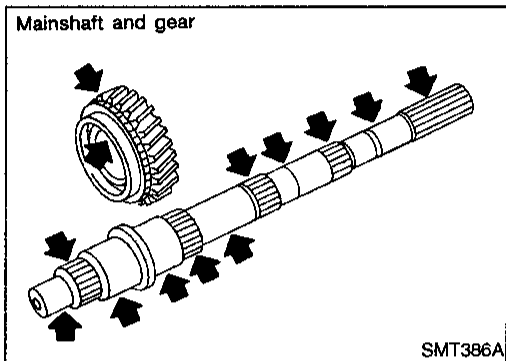
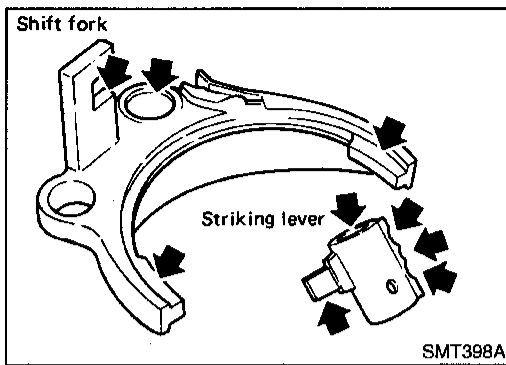

Shift Control Components

INSPECTION

NAMT0011

- Check contact surface and sliding surface for wear, scratches, projections or other damage.

Gear Components

INSPECTION

NAMT0012

Gears and Shafts

NAMT0012S01

- Check shafts for cracks, wear or bending.
- Check gears for excessive wear, chips or cracks.

Synchronizers

NAMT0012S02

- Check spline portion of coupling sleeves, hubs, and gears for wear or cracks.
- Check baulk rings for cracks or deformation.
- Check shifting inserts for wear or deformation.
- Check insert springs for deformation.

- Measure wear of main drive, 1st and OD baulk rings.

Clearance between baulk ring and gear:

Refer to SDS, MT-35.

- If the clearance is smaller than the wear limit, replace baulk ring.

INSPECTION

Gear Components (Cont'd)

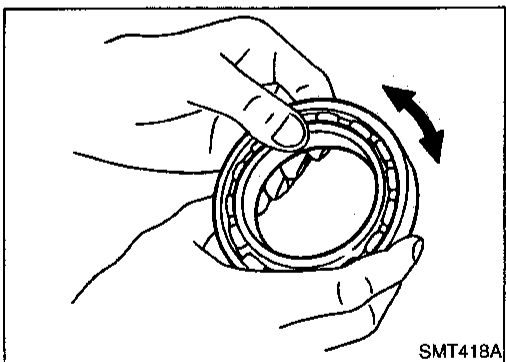
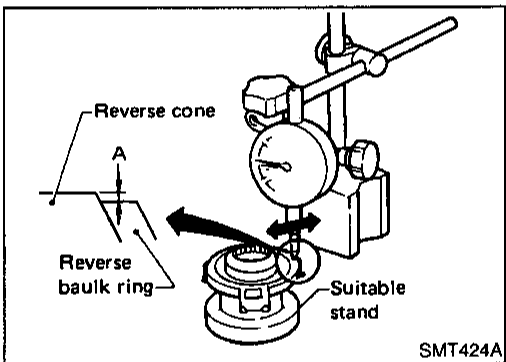
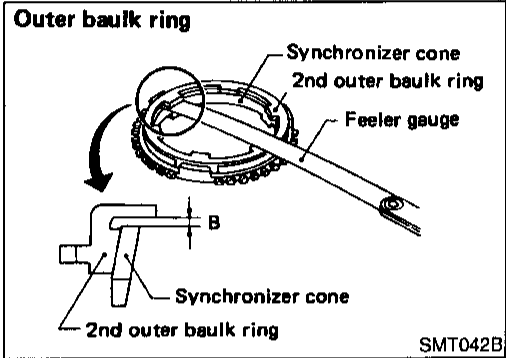
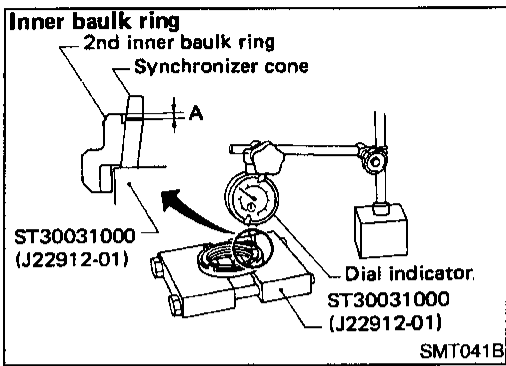

- Measure wear of 2nd and 3rd baulk rings.
 - a) Place baulk rings in position on synchronizer cone.
 - b) While holding baulk rings against synchronizer cone as far as it will go, measure dimensions "A" and "B".

Standard:

A 0.7 - 0.9 mm (0.028 - 0.035 in)

B 0.6 - 1.1 mm (0.024 - 0.043 in)

Wear limit:

0.2 mm (0.008 in)

- If dimension "A" or "B" is smaller than the wear limit, replace outer baulk ring, inner baulk ring and synchronizer cone as a set.

- Measure wear of reverse baulk ring.
 - a) Place baulk ring in position on reverse cone.
 - b) While holding baulk ring against reverse cone as far as it will go, measure dimension "A" with dial indicator.

Dimension "A":

Standard -0.1 to 0.35 mm (-0.0039 to 0.0138 in)

Wear limit 0.7 mm (0.028 in)

- c) If dimension "A" is larger than the wear limit, replace baulk ring.

Bearings

NAMT0012503

- Make sure bearings roll freely and are free from noise, crack, pitting or wear.

GI

MA

EM

LC

EC

FE

CL

MT

AT

TF

PD

AX

SU

BR

ST

RS

BT

HA

SC

EL

IDX

ASSEMBLY

Gear Components ASSEMBLY

NAMT0013

Counter gear front bearing in transmission case

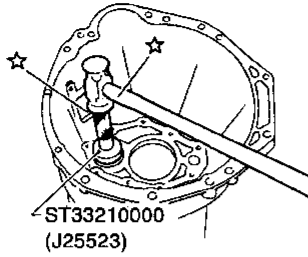

Mainshaft front bearing in adapter plate

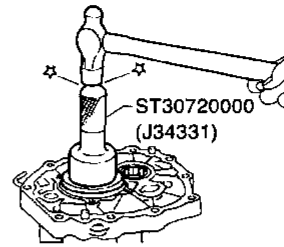

Mainshaft rear bearing in OD gear case
(4WD model)

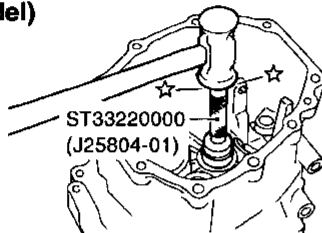

Counter gear rear bearing in adapter plate

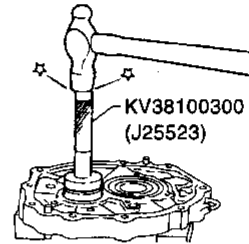

Be flush with front surface of OD gear case.

SMT207D

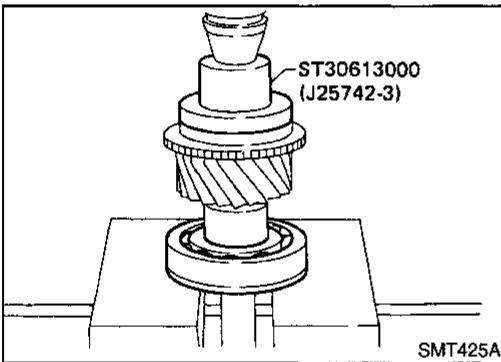

SMT425A

1. Install bearings into case components.
2. Install main drive gear bearing.
 - a. Press main drive gear bearing.

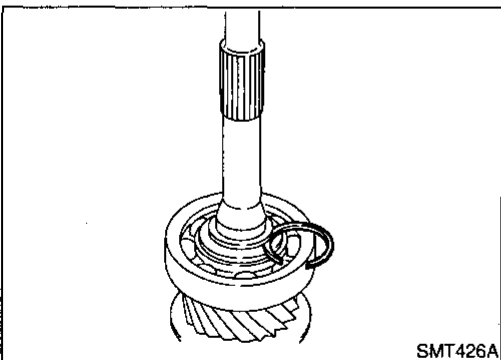

SMT426A

- b. Select proper main drive gear snap ring to minimize clearance of groove.

Allowable clearance of groove:

0 - 0.1 mm (0 - 0.004 in)

Main drive gear snap ring:

Refer to SDS, MT-36.

- c. Install selected snap ring on main drive gear.

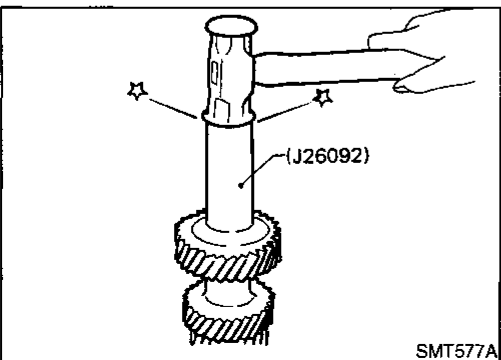

SMT577A

3. Install components on counter gear.
 - a. Install sub-gear components.
 - When installing sub-gear snap ring, tap sub-gear snap ring into position on counter gear.

ASSEMBLY

Gear Components (Cont'd)

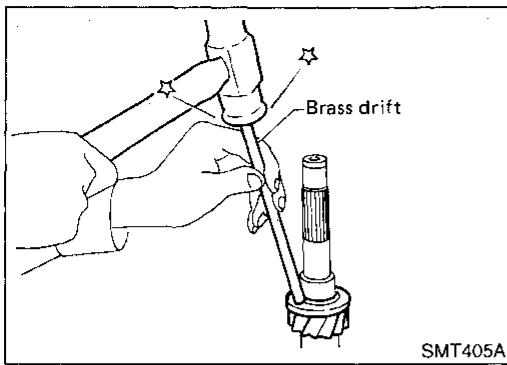

b. Install counter gear rear thrust bearing.

GI

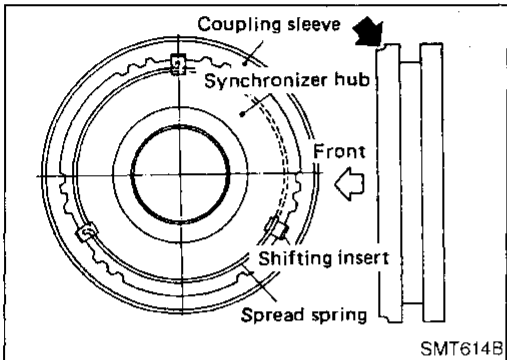

4. Install front side components on mainshaft.
a. Assemble 1st & 2nd synchronizer.

MA

EM

LC

EC

FE

CL

MT

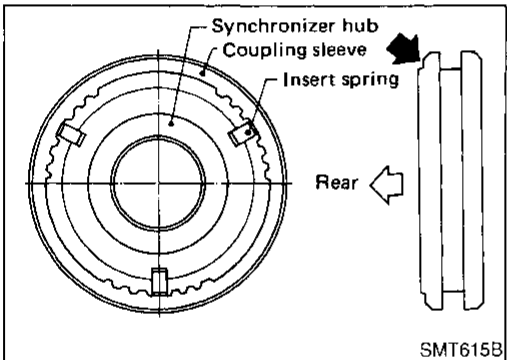

b. Assemble 3rd & 4th synchronizer.

AT

TF

PD

AX

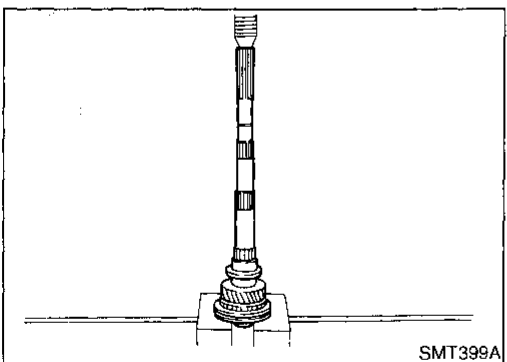

c. Press on 3rd & 4th synchronizer assembly together with 3rd main gear and 3rd gear needle bearing.

SU

● Pay attention to direction of synchronizer assembly.

BR

ST

RS

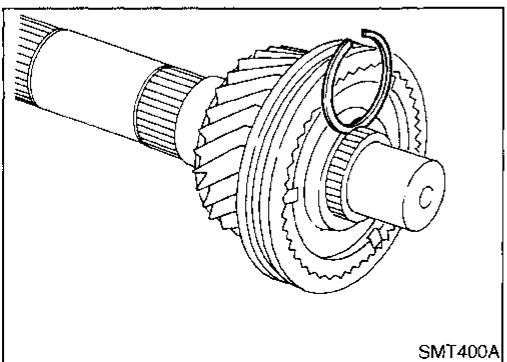

d. Select proper snap ring to minimize clearance of groove.

BT

Allowable clearance of groove:

HA

0 - 0.1 mm (0 - 0.004 in)

Mainshaft front snap ring:

SC

Refer to SDS, MT-36.

e. Install selected snap ring on mainshaft.

EL

IDX

ASSEMBLY

Gear Components (Cont'd)

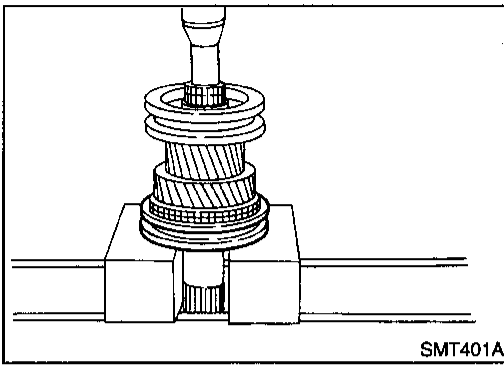

- f. Press on 1st & 2nd synchronizer assembly together with 2nd main gear and 2nd gear needle bearing.

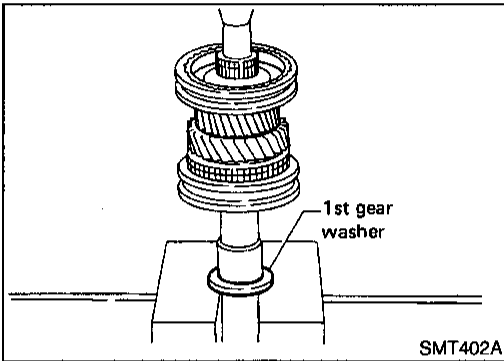

- g. Press on 1st gear bushing using 1st gear washer.
- h. Install 1st main gear and needle bearing.

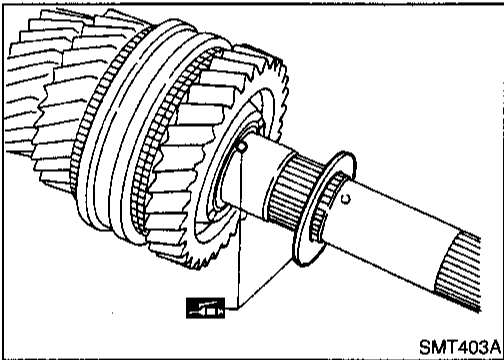

- i. Install steel ball and 1st gear washer.
- **Apply multi-purpose grease to steel ball and 1st gear washer before installing.**

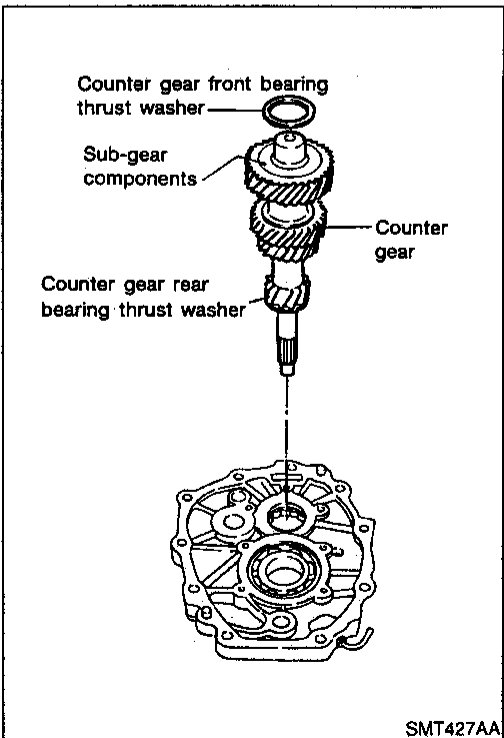

- 5. Select proper counter gear front bearing thrust washer when replacing transmission case, counter gear, counter gear rear thrust bearing or sub-gear components.
 - a. Install counter gear with sub-gear components, counter gear front and rear bearing thrust washer on adapter plate.
 - b. Remove counter gear front bearing thrust washer from transmission case.
 - c. Place adapter plate and counter gear assembly in transmission case (case inverted).

ASSEMBLY

Gear Components (Cont'd)

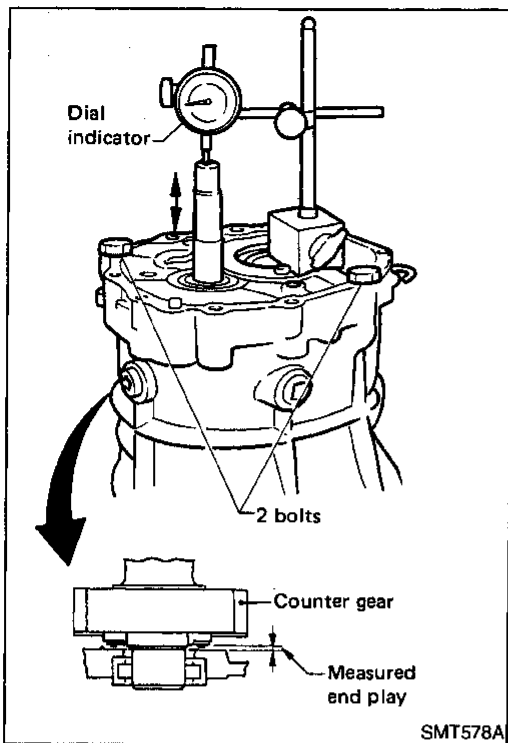

- d. Tighten adapter plate to transmission case using 2 bolts.
- e. Place dial indicator on rear end of counter gear.
- f. Move counter gear up and down and measure dial indicator deflection.
- g. Select proper thrust washer using table below as a guide.

Counter gear end play:

0.10 - 0.25 mm (0.0039 - 0.0098 in)

Table for selecting proper counter gear front bearing thrust washer:

Refer to SDS, MT-37.

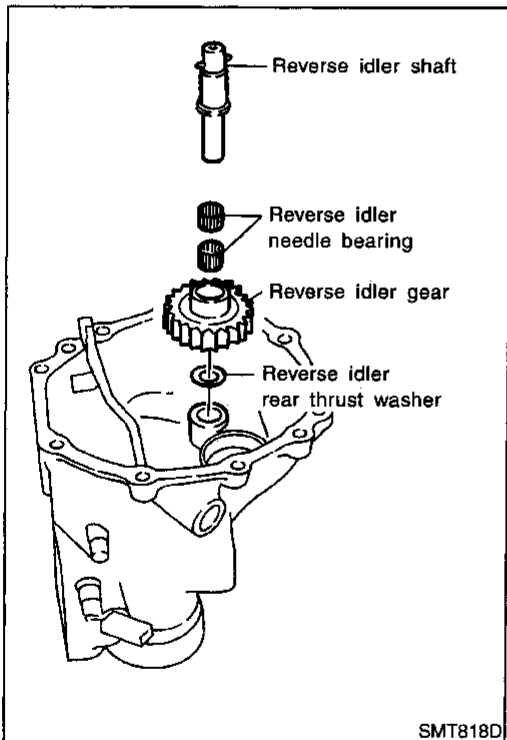

6. Select proper reverse idler rear thrust washer when replacing rear extension (or OD gear case), reverse idler gear, reverse idler shaft.
 - a. Install reverse idler gear, reverse idler needle bearings and reverse idler shaft into rear extension (or OD gear case).
- **When replacing reverse idler rear thrust washer, install either A or B.**

Reverse idler rear thrust washer:

Refer to SDS, MT-37.

GI

MA

EM

LC

EC

FE

CL

MT

AT

TF

PD

AX

SU

BR

ST

RS

BT

HA

SC

EL

IDX

ASSEMBLY

Gear Components (Cont'd)

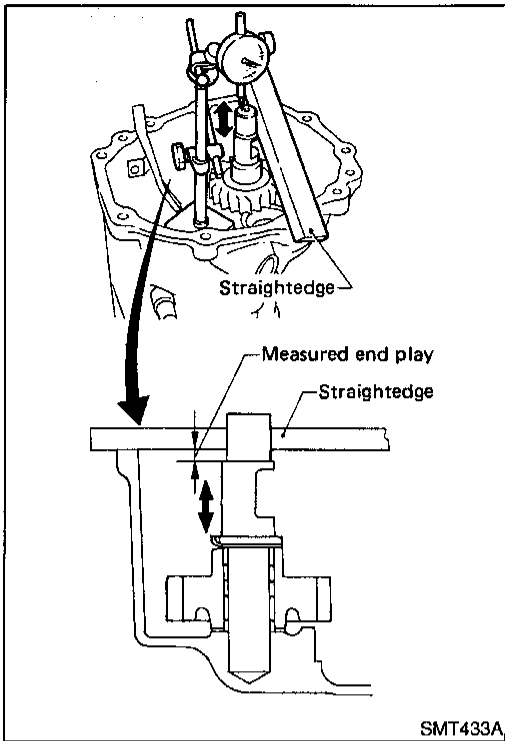

- b. Place dial indicator on front end of reverse idler shaft.
- c. Put straightedge on front surface of rear extension (or OD gear case) as a stopper of reverse idler shaft.
- d. Move reverse idler shaft up and down and measure reverse idler gear end play.

Reverse idler gear end play:

0.30 - 0.53 mm (0.0118 - 0.0209 in)

- e. If not within specification, replace reverse idler rear thrust washer with the other (A or B) and check again.

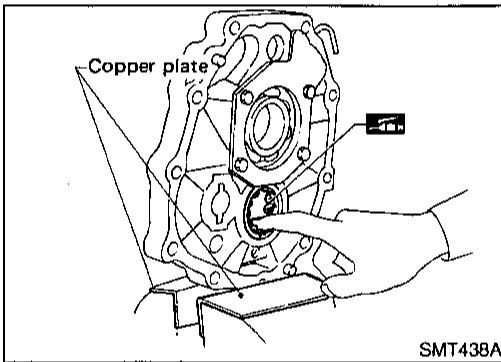

7. Install mainshaft and counter gear on adapter plate and main drive gear on mainshaft.
 - a. Mount adapter plate on vise and apply multi-purpose grease to counter gear rear bearing.

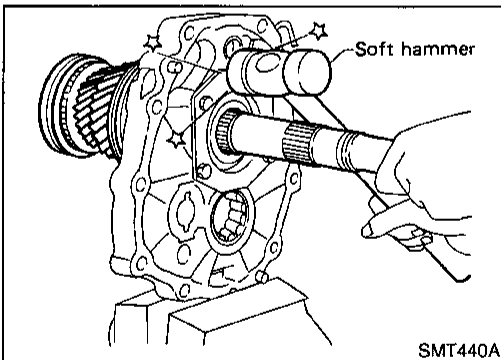

- b. Install mainshaft a little on mainshaft front bearing.
 - To allow for installation of counter gear, do not install mainshaft completely.

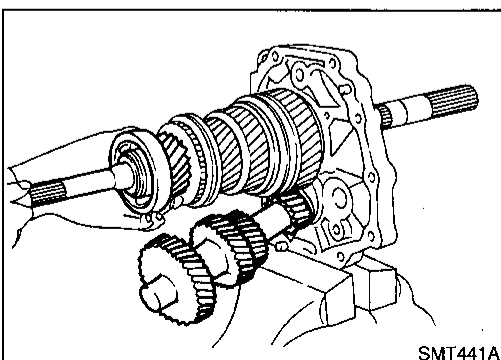

- c. Install counter gear on counter gear rear bearing and install main drive gear, pilot bearing and spacer on mainshaft.

ASSEMBLY

Gear Components (Cont'd)

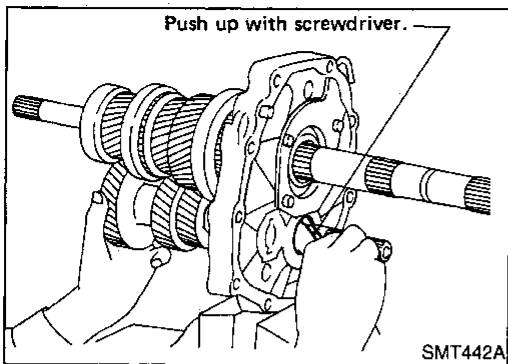

- When installing counter gear into counter gear rear bearing, push up on upper roller of counter gear rear bearing with screwdriver.

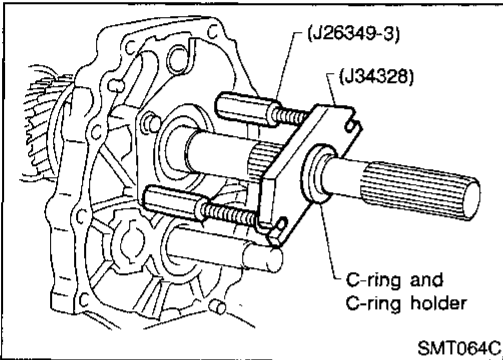

- d. Install Tools (J26349-3) onto adapter plate and C-ring and C-ring holder on mainshaft.
- e. Install Tool (J34328) on mainshaft.

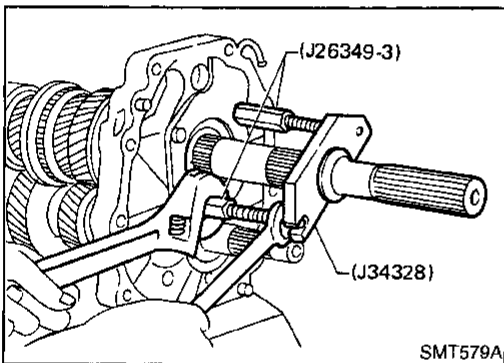

- f. Install mainshaft and counter gear completely by extending length of (J26349-3).

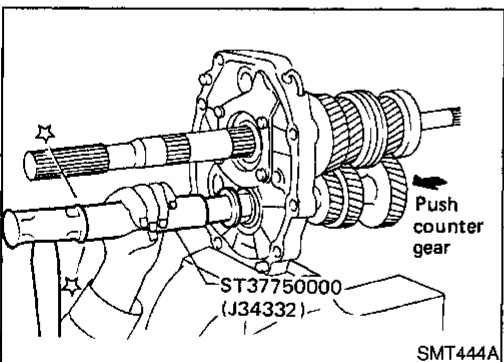

- 8. Install rear side components on mainshaft and counter gear.
 - a. Install OD gear bushing while pushing on the front of counter gear.

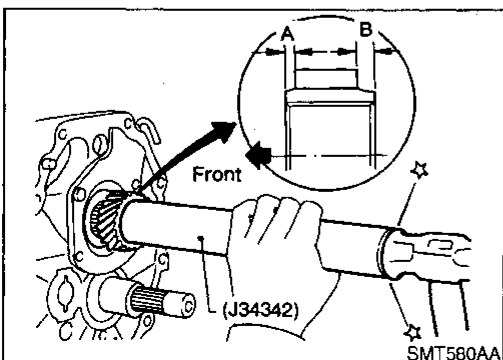

- b. Install OD main gear.
 - Pay attention to direction of OD main gear. (B is wider than A as shown at left.)
- c. Install adapter plate with gear assembly onto transmission case.
- d. Install OD gear needle bearing and then install OD counter gear and reverse idler shaft.

GI
MA
EM
LC
EC
FE
CL
MT
AT
TF
PD
AX
SU
BR
ST
RS
BT
HA
SC
EL
IDX

ASSEMBLY

Gear Components (Cont'd)

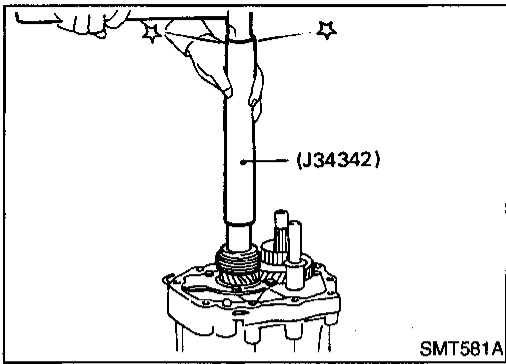

- e. Install reverse gear bushing with speedometer drive gear (2WD model).

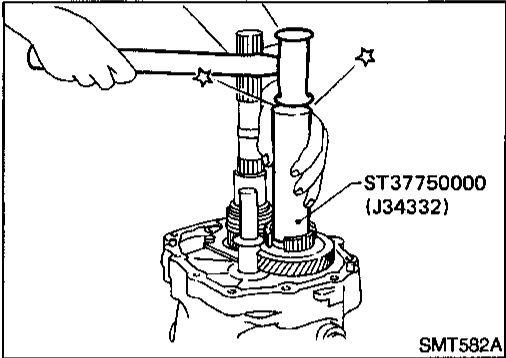

- f. Install reverse cone.

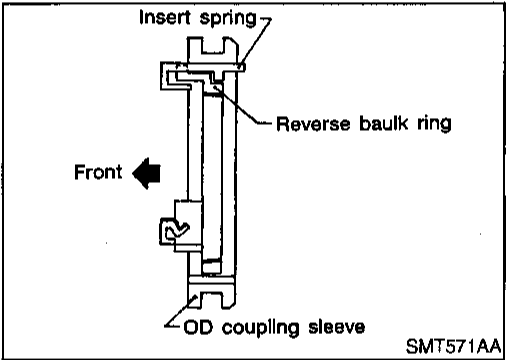

- g. Install insert springs and reverse baulk ring on OD coupling sleeve. Then install them and OD baulk ring on OD counter gear.

- Pay attention to direction of OD coupling sleeve.

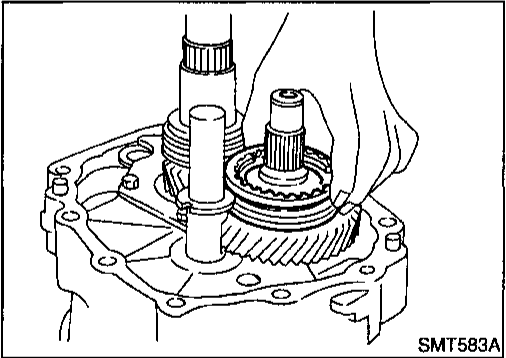

- h. Install reverse counter gear.

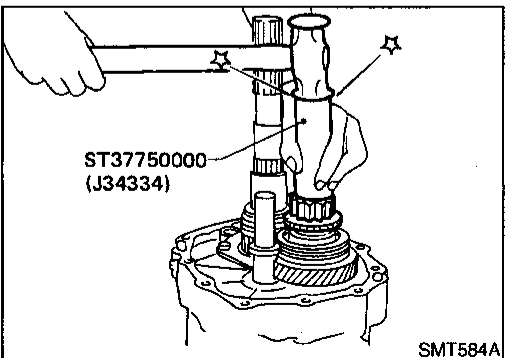

- i. Install reverse gear needle bearing and then install reverse main gear, reverse idler gear and reverse idler thrust washers.

ASSEMBLY

Gear Components (Cont'd)

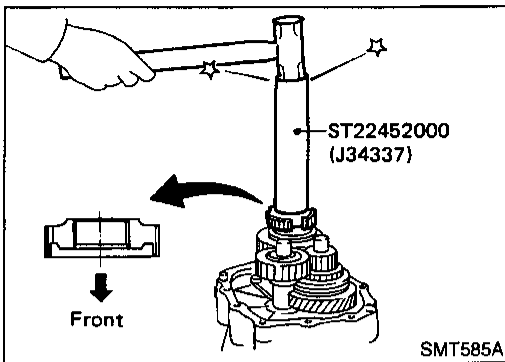

- j. Install reverse hub.
- Pay attention to its direction.

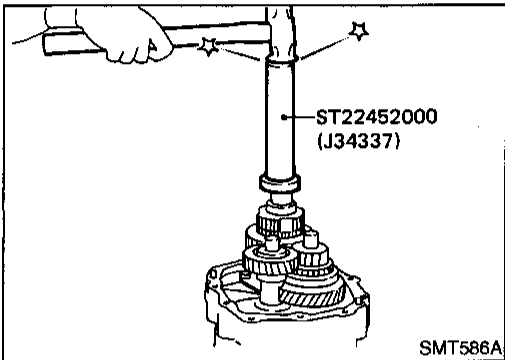

- k. Install mainshaft spacer and mainshaft rear bearing (2WD model).

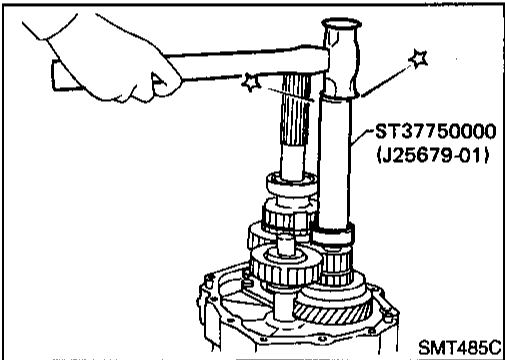

- l. Install counter gear rear end bearing.
- m. Separate adapter plate from transmission case and mount adapter plate on vice again.

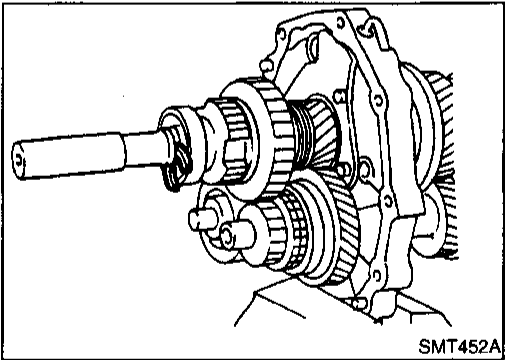

- n. Select proper mainshaft C-ring to minimize clearance of groove.

Allowable clearance of groove:

0 - 0.1 mm (0 - 0.004 in)

Mainshaft C-ring:

Refer to SDS, MT-37.

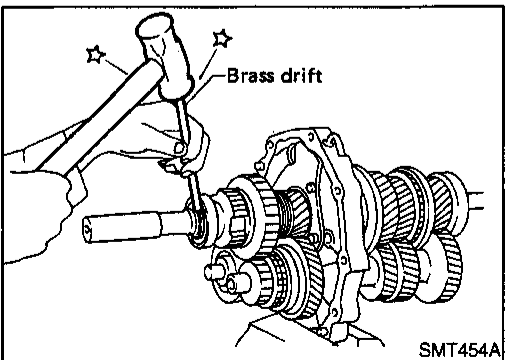

- o. Install selected C-ring, C-ring holder and mainshaft rear snap ring.

GI

MA

EM

LC

EC

FE

CL

MT

AT

TF

PD

AX

SU

BR

ST

RS

BT

HA

SC

EL

IDX

ASSEMBLY

Gear Components (Cont'd)

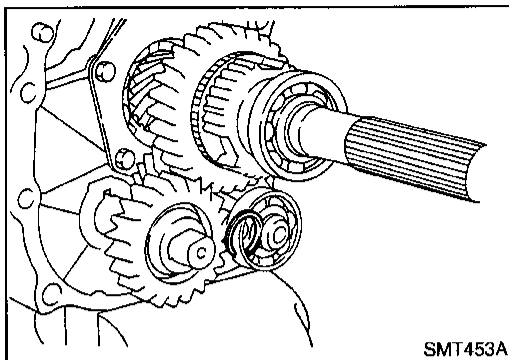

- p. Select proper counter gear rear snap ring to minimize clearance of groove.

Allowable clearance of groove:

0 - 0.1 mm (0 - 0.004 in)

Counter gear rear snap ring:

Refer to SDS, MT-37.

- q. Install selected counter gear rear snap ring.

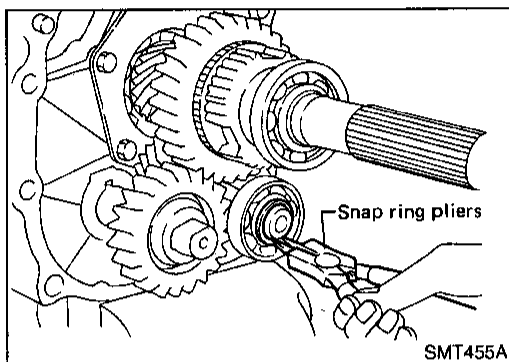

- r. Install reverse coupling sleeve.

- **Pay attention to its direction.**

- s. Measure each gear end play as a final check. Refer to "DISASSEMBLY", MT-18.

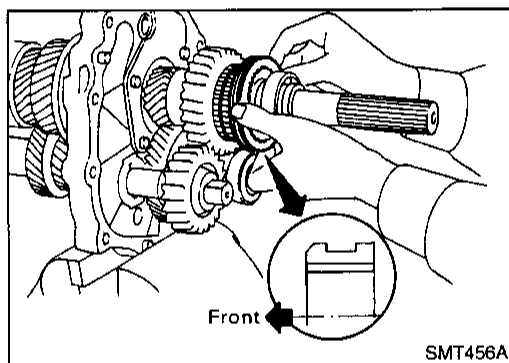

Shift Control Components

ASSEMBLY

NAMT0014

1. Install OD fork rod and OD shift fork. Then install retaining pin into OD shift fork.

2. Install 1st & 2nd, 3rd & 4th and reverse shift fork onto coupling sleeve.

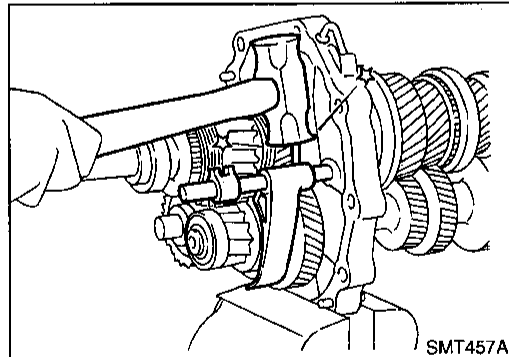

3. Install striking rod into hole of shift forks, striking lever and interlock and then install retaining pin into striking lever.

- **Make sure that striking rod moves smoothly.**

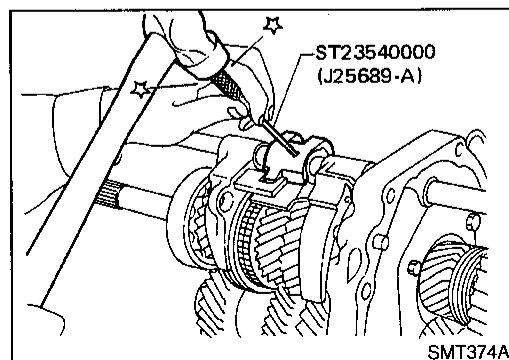

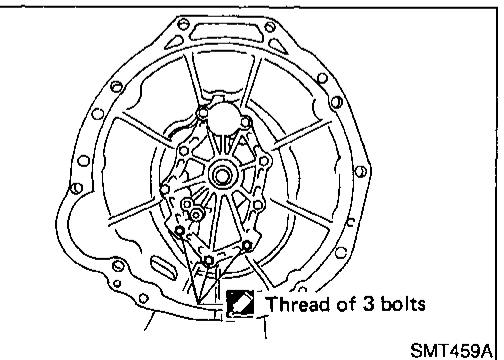
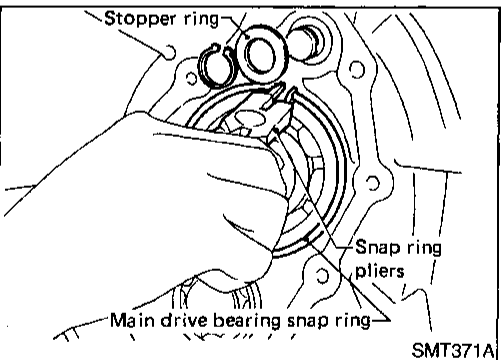
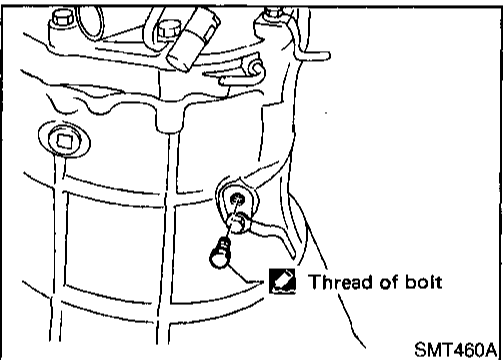
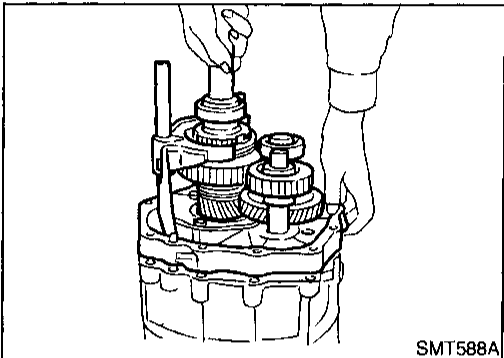
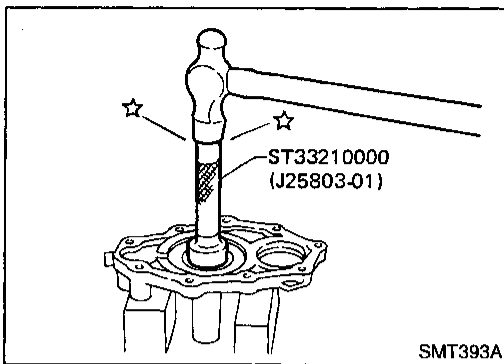

Case Components

ASSEMBLY

NAMT0015

1. Install front cover oil seal.
 - **Apply multi-purpose grease to seal lip.**
2. Install selected counter gear front bearing shim onto transmission case.
 - **Apply multi-purpose grease.**
3. Apply sealant to mating surface of transmission case.
4. Install gear assembly onto transmission case.
5. Install check spring and check ball into interlock stopper.
 - **Apply multi-purpose grease to check ball.**
6. Install interlock stopper assembly and then tighten check ball plug.
 - **Apply sealant to thread of check ball plug. Refer to Shift Control Components, MT-15.**
7. Install stopper ring and main drive bearing snap ring.
8. Install front cover and gasket.
 - **Apply sealant to thread of 3 bolts shown left. Refer to Case Components, MT-12.**
9. Apply sealant to mating surface of adapter plate.

GI

MA

EM

LC

EC

FE

CL

MT

AT

TF

PD

AX

SU

BR

ST

RS

BT

HA

SC

EL

IDX

ASSEMBLY

Case Components (Cont'd)

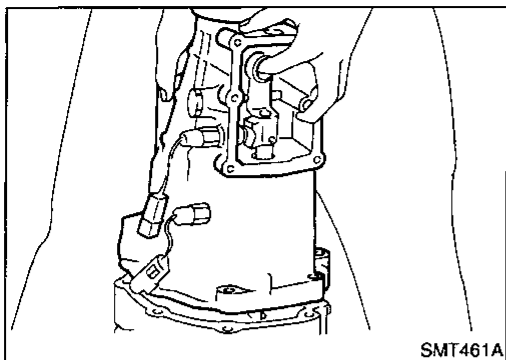

10. Install rear extension (or OD gear case) together with striking arm.

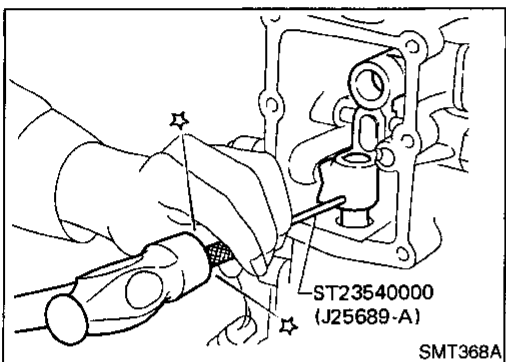

11. Install retaining pin into striking arm.

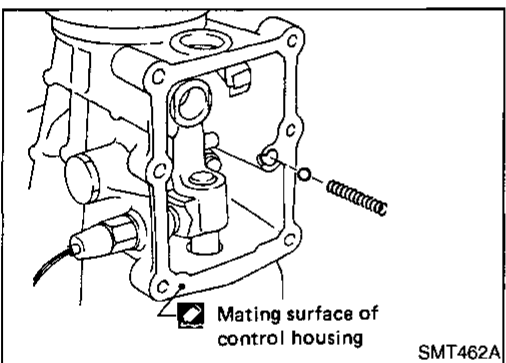

12. Install return spring and check ball and then install control housing.

- **Apply sealant to mating surface of rear extension (or OD gear case).**
Refer to Case Components, MT-12.

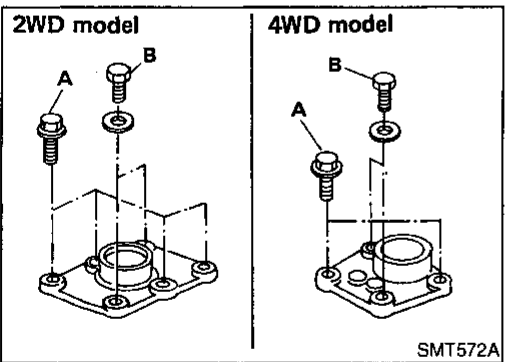

13. Tighten control housing bolts.

Bolt head size:

A bolts 12 mm (0.47 in)

B bolts 13 mm (0.51 in)

SERVICE DATA AND SPECIFICATIONS (SDS)

General Specifications

General Specifications

NAMT0016

Applied model	VG33E		
	2WD	4WD	
Transmission	FS5R30A		
Number of speed	5		
Shift pattern			
Synchromesh type	Warner		
	Gear ratio	Number of teeth	
		Mainshaft	Countershaft
Drive	—	22	32
1st	3.580	32	13
2nd	2.077	30	21
3rd	1.360	29	31
4th	1.000	—	—
OD	0.811	24	43
Reverse	3.636	30	12
Reverse idler gear	22		
Oil capacity <i>l</i> (US pt, Imp pt)	2.4 (5-1/8, 4-1/4)		5.1 (10-3/4, 9)
Remarks	2nd & 3rd double baulk ring type synchronizer		

Gear End Play

NAMT0017
Unit: mm (in)

Gear	End play
1st main gear	0.23 - 0.33 (0.0091 - 0.0130)
2nd main gear	0.23 - 0.33 (0.0091 - 0.0130)
3rd main gear	0.06 - 0.16 (0.0024 - 0.0063)
OD counter gear	0.23 - 0.33 (0.0091 - 0.0130)
Reverse main gear	0.33 - 0.43 (0.0130 - 0.0169)
Counter gear	0.10 - 0.25 (0.0039 - 0.0098)
Reverse idler gear	0.30 - 0.53 (0.0118 - 0.0209)

Clearance Between Baulk Ring and Gear

NAMT0018
Unit: mm (in)

	Standard	Wear limit
1st	1.05 - 1.3 (0.0413 - 0.0512)	0.7 (0.028)
Main drive	1.05 - 1.3 (0.0413 - 0.0512)	
OD	1.05 - 1.3 (0.0413 - 0.0512)	

SERVICE DATA AND SPECIFICATIONS (SDS)

Clearance Between Baulk Ring and Gear (Cont'd)

2ND AND 3RD BAULK RING

NAMT0019S01
Unit: mm (in)

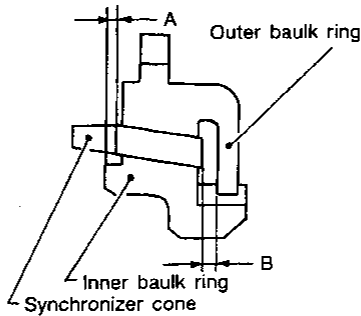

SMT742C

Dimension	Standard	Wear limit
A	0.7 - 0.9 (0.028 - 0.035)	0.2 (0.008)
B	0.6 - 1.1 (0.024 - 0.043)	

Distance Between Rear Surface of Reverse Cone and Reverse Baulk Ring

NAMT0019
Unit: mm (in)

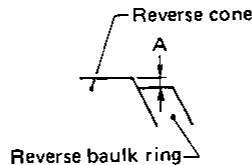

SMT428C

Dimension "A"	Standard	Wear limit
	-0.1 to 0.35 (-0.0039 to 0.0138)	0.7 (0.028)

Available Snap Ring

NAMT0020

MAIN DRIVE GEAR SNAP RING

NAMT0020S01
Unit: mm (in)

Allowable clearance		0 - 0.1 (0 - 0.004)	
Thickness	Part number	Thickness	Part number
1.89 (0.0744)	32204-01G60	2.03 (0.0799)	32204-01G63
1.95 (0.0768)	32204-01G61	2.07 (0.0815)	32204-01G64
1.99 (0.0783)	32204-01G62	2.11 (0.0831)	32204-01G65

MAINSHAFT FRONT SNAP RING

NAMT0020S02
Unit: mm (in)

Allowable clearance		0 - 0.1 (0 - 0.004)	
Thickness	Part number	Thickness	Part number
1.99 (0.0783)	32204-01G62	2.11 (0.0831)	32204-01G65
2.03 (0.0799)	32204-01G63	2.15 (0.0846)	32204-01G66
2.07 (0.0815)	32204-01G64	2.19 (0.0862)	32204-01G67

SERVICE DATA AND SPECIFICATIONS (SDS)

Available Snap Ring (Cont'd)

COUNTER GEAR REAR SNAP RING

NAMT0020S03
Unit: mm (in)

Allowable clearance 0 - 0.1 (0 - 0.004)			
Thickness	Part number	Thickness	Part number
1.32 (0.0520)	32236-01G00	1.56 (0.0614)	32236-01G04
1.38 (0.0543)	32236-01G01	1.62 (0.0638)	32236-01G05
1.44 (0.0567)	32236-01G02	1.68 (0.0661)	32236-01G06
1.50 (0.0591)	32236-01G03	1.74 (0.0685)	32236-01G07

Available C-ring

MAINSHAFT C-RING

NAMT0021
NAMT0021S01
Unit: mm (in)

Allowable clearance 0 - 0.1 (0 - 0.004)			
Thickness	Part number	Thickness	Part number
2.63 (0.1035)	32348-01G15	3.19 (0.1256)	32348-01G07
2.70 (0.1063)	32348-01G00	3.26 (0.1283)	32348-01G08
2.77 (0.1091)	32348-01G01	3.33 (0.1311)	32348-01G09
2.84 (0.1118)	32348-01G02	3.40 (0.1339)	32348-01G10
2.91 (0.1146)	32348-01G03	3.47 (0.1366)	32348-01G11
2.98 (0.1173)	32348-01G04	3.54 (0.1394)	32348-01G12
3.05 (0.1201)	32348-01G05	3.61 (0.1421)	32348-01G13
3.12 (0.1228)	32348-01G06	3.68 (0.1449)	32348-01G14

Available Shim and Washer

TABLE FOR SELECTING PROPER COUNTER GEAR FRONT BEARING THRUST WASHER

NAMT0022
NAMT0022S01
Unit: mm (in)

Dial indicator deflection	Thickness of proper washer	Part number
0.93 - 1.02 (0.0366 - 0.0402)	0.80 (0.0315)	32218-01G00
1.01 - 1.10 (0.0398 - 0.0433)	0.88 (0.0346)	32218-01G11
1.09 - 1.18 (0.0429 - 0.0465)	0.96 (0.0378)	32218-01G12
1.17 - 1.26 (0.0461 - 0.0496)	1.04 (0.0409)	32218-01G13
1.25 - 1.34 (0.0492 - 0.0528)	1.12 (0.0441)	32218-01G14
1.33 - 1.42 (0.0524 - 0.0559)	1.20 (0.0472)	32218-01G04
1.41 - 1.50 (0.0555 - 0.0591)	1.28 (0.0504)	32218-01G15
1.49 - 1.58 (0.0587 - 0.0622)	1.36 (0.0535)	32218-01G16
1.57 - 1.66 (0.0618 - 0.0654)	1.44 (0.0567)	32218-01G17

REVERSE IDLER REAR THRUST WASHER

NAMT0022S02
Unit: mm (in)

Thickness	Part number
A	1.97 (0.0776) 32284-01G10
B	2.07 (0.0815) 32284-01G11

GI
MA
EM
LC
EC
FE
CL
MT
AT
TF
PD
AX
SU
BR
ST
RS
BT
HA
SC
EL
IDX
727