

SECTION **CL**

CONTENTS

PRECAUTIONS	2	Removal	10
Precautions	2	Inspection	11
PREPARATION	3	Installation	11
Special Service Tools	3	Lubrication	11
Commercial Service Tools	3	Waterproof - for 4WD Model	12
NOISE, VIBRATION AND HARSHNESS (NVH)		CLUTCH DISC, CLUTCH COVER AND	
TROUBLESHOOTING	4	FLYWHEEL	13
NVH Troubleshooting Chart	4	Components	13
CLUTCH	4	Removal	13
CLUTCH SYSTEM - HYDRAULIC TYPE	5	Inspection	13
Components	5	Inspection and Adjustment	14
Inspection and Adjustment	6	CLUTCH DISC	14
ADJUSTING CLUTCH PEDAL	6	FLYWHEEL INSPECTION	14
AIR BLEEDING PROCEDURE	7	Installation	14
CLUTCH MASTER CYLINDER	8	SERVICE DATA AND SPECIFICATIONS (SDS)	16
Components	8	Clutch Control System	16
Disassembly and Assembly	8	Clutch Master Cylinder (With damper)	16
Inspection	8	Clutch Operating Cylinder	16
OPERATING CYLINDER	9	Clutch Disc	16
Components	9	Clutch Cover	16
Inspection	9	Clutch Pedal	16
CLUTCH RELEASE MECHANISM	10		
Components	10		

PRECAUTIONS

Precautions

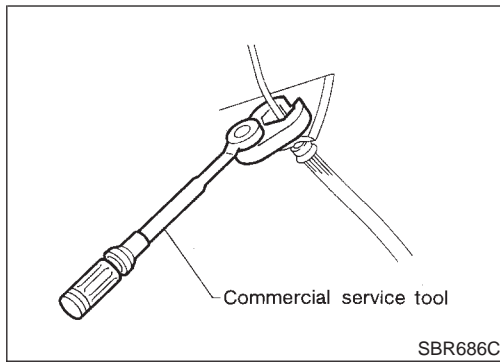

Precautions

NACL0001

- Recommended fluid is brake fluid “DOT 3”.
- Never reuse drained brake fluid.
- Be careful not to splash brake fluid on painted areas.
- When removing and installing clutch piping, use Tool.
- Use new brake fluid to clean or wash all parts of master cylinder, operating cylinder and clutch damper.
- Never use mineral oils such as gasoline or kerosene. It will ruin the rubber parts of the hydraulic system.

WARNING:

After cleaning the clutch disc, wipe it with a dust collector. Do not use compressed air.

PREPARATION

Special Service Tools

Special Service Tools

NACL0002

The actual shapes of Kent-Moore tools may differ from those of special service tools illustrated here.

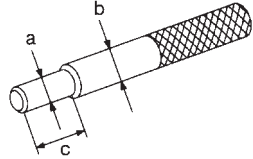
Tool number (Kent-Moore No.) Tool name	Description
ST20670000 (—) Clutch aligning bar	 <p>Installing clutch cover and clutch disc a: 15 mm (0.59 in) dia. b: 23 mm (0.91 in) dia. c: 30 mm (1.18 in)</p> <p>NT405</p>

GI

MA

EM

LC

EC

FE

CL

MT

AT

Commercial Service Tools

NACL0003

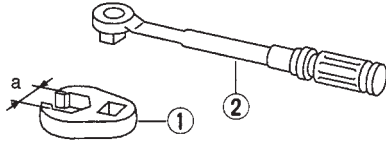
Tool name	Description
1 Flare nut crowfoot 2 Torque wrench	 <p>Removing and installing clutch piping a: 10 mm (0.39 in)</p> <p>NT360</p>

TF

PD

AX

SU

BR

ST

RS

BT

HA

SC

EL

IDX

NOISE, VIBRATION AND HARSHNESS (NVH) TROUBLESHOOTING

NACL0027

NVH Troubleshooting Chart

NVH Troubleshooting Chart

NACL0027S01

Use the chart below to help you find the cause of the problem. The numbers indicate the priority of the likely cause of the problem. Check each part in order. If necessary, repair or replace these parts.

CLUTCH

NACL0027S01/01

Reference page	CL-6	CL-7	CL-8	CL-9	Refer to EM-59, "REMOVAL".	CL-10	CL-14	CL-14	CL-14	CL-14	CL-14	CL-14	CL-14	CL-14	CL-14	CL-14	CL-14	CL-14	CL-14	
SUSPECTED PARTS (Possible cause)	CLUTCH PEDAL (Free play out of adjustment)																			
	CLUTCH LINE (Air in line)		1																	
	MASTER CYLINDER PISTON CUP (Damaged)			2																
	OPERATING CYLINDER PISTON CUP (Damaged)				2															
	ENGINE MOUNTING (Loose)					1														
	RELEASE BEARING (Worn, dirty or damaged)						1													
	CLUTCH DISC (Out of true)																			
	CLUTCH DISC (Runout is excessive)									2										
	CLUTCH DISC (Lining broken)																			
	CLUTCH DISC (Dirty or burned)																			
	CLUTCH DISC (Oily)														2					
	CLUTCH DISC (Worn out)																			
	CLUTCH DISC (Hardened)																			
	CLUTCH DISC (Lack of spline grease)																			
	DIAPHRAGM SPRING (Damaged)																			
	PRESSURE PLATE (Distortion)																			
	FLYWHEEL (Distortion)																			
Symptom	Clutch grabs/chatters																			
	Clutch pedal spongy																			
	Clutch noisy																			
	Clutch slips																			
Clutch does not disengage																				

CLUTCH SYSTEM — HYDRAULIC TYPE

Components

Components

NACL0004

SEC. 300•305•306•465

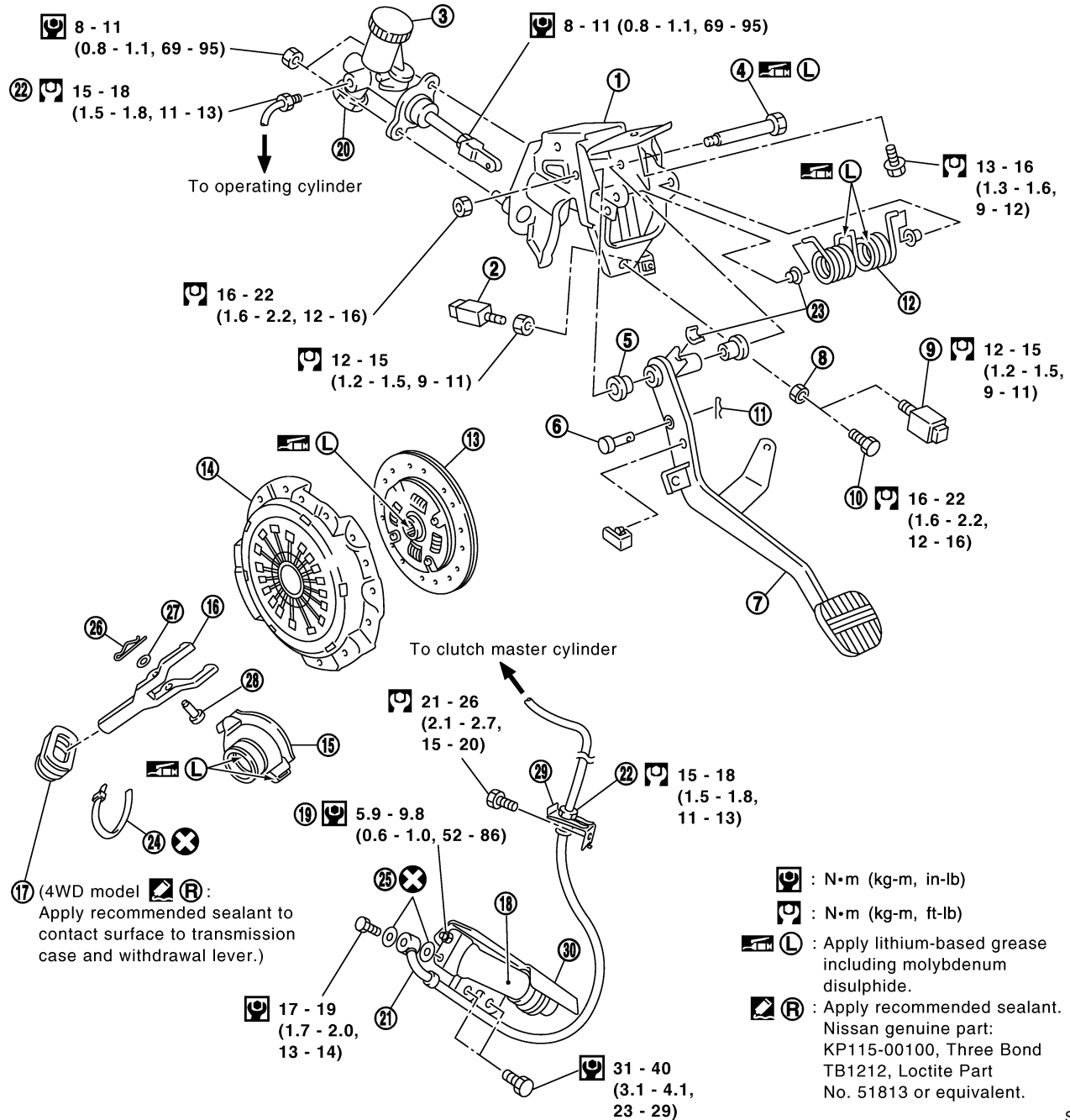

SCL885

- | | | |
|----------------------------|-------------------------------------|---------------------------------|
| 1. Clutch pedal bracket | 11. Snap pin | 21. Clutch hose |
| 2. Clutch interlock switch | 12. Assist spring | 22. Flare nut |
| 3. Clutch master cylinder | 13. Clutch disc | 23. Bushing |
| 4. Fulcrum pin | 14. Clutch cover | 24. Dust cover clip (4WD model) |
| 5. Bushing | 15. Release bearing | 25. Copper washer |
| 6. Clevis pin | 16. Withdrawal lever | 26. Snap pin |
| 7. Clutch pedal | 17. Dust boot | 27. Washer |
| 8. Lock nut | 18. Operating cylinder | 28. Withdrawal shaft |
| 9. ASCD cancel switch | 19. Air bleeder | 29. Lock spring |
| 10. Pedal stopper | 20. Clutch damper (not serviceable) | 30. Heat insulator |

GI
MA
EM
LC
EC
FE
CL
MT
AT
TF
PD
AX
SU
BR
ST
RS
BT
HA
SC
EL
IDX

CLUTCH SYSTEM — HYDRAULIC TYPE

Inspection and Adjustment

NACL0005

NACL0005S01

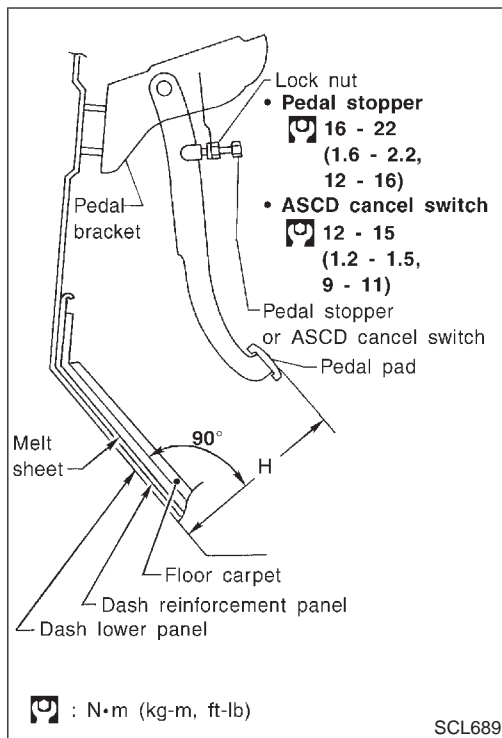

Inspection and Adjustment

ADJUSTING CLUTCH PEDAL

1. Adjust pedal height with pedal stopper or ASCD cancel switch.

Pedal height "H":

186 - 196 mm (7.32 - 7.72 in)

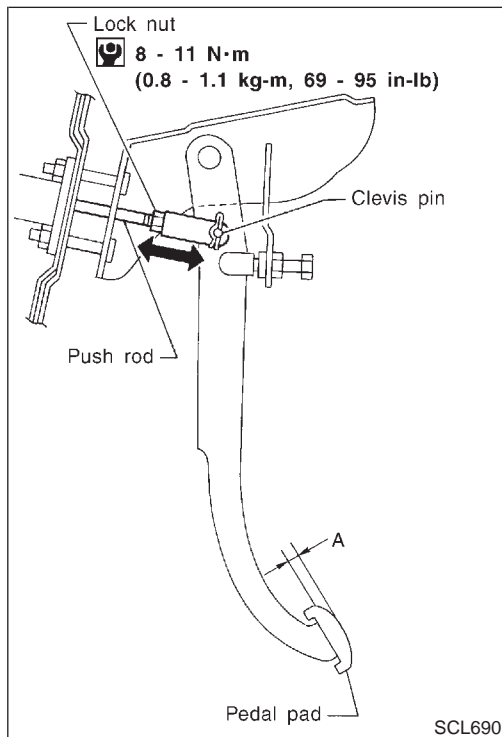

2. Adjust pedal free play with master cylinder push rod. Then tighten lock nut.

Pedal free play (measured at pedal pad) "A":

9 - 16 mm (0.35 - 0.63 in)

Pedal free play means the following total measured at position of pedal pad:

- Play due to clevis pin and clevis pin hole in clutch pedal.
3. Make sure that clevis pin can rotate smoothly. If not, readjust pedal free play with master cylinder push rod.

CLUTCH SYSTEM — HYDRAULIC TYPE

Inspection and Adjustment (Cont'd)

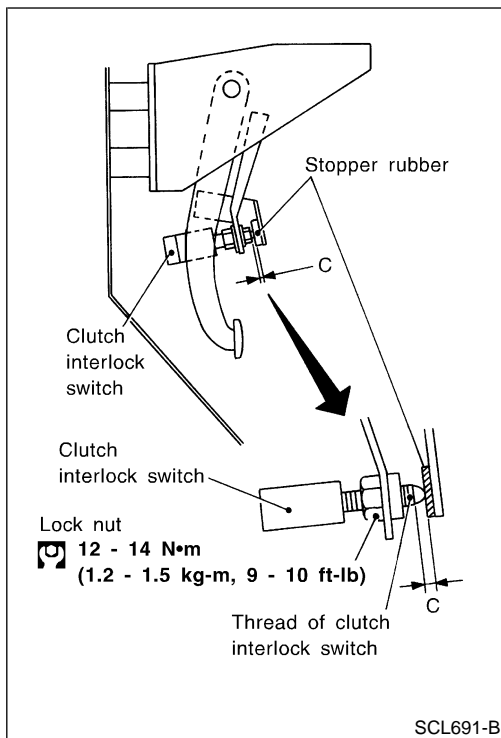

— Models with Clutch Interlock System —

- Adjust clearance "C" shown in the figure while fully depressing clutch pedal.

Clearance C:

0.1 - 1.5 mm (0.004 - 0.059 in)

AIR BLEEDING PROCEDURE

CAUTION:

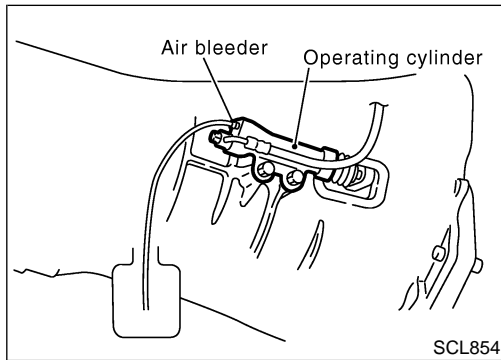

- Check the clutch fluid level of the reservoir for shortage.
 - Keep clutch fluid away from the coating surface of the body or other parts. If it adheres, remove it quickly and flush the area with water.
1. Fill up master cylinder reservoir tank with new clutch fluid.
 2. Connect a clear vinyl hose to air bleeder.
 3. Carefully depress clutch pedal fully and release it. Repeat the cycle several times at an interval of 2 or 3 seconds.
 4. While depressing clutch pedal, open air bleeder.
 5. Close air bleeder.
 6. Release clutch pedal, and wait for approx. 5 seconds.
 7. Repeat steps 3 to 6 until no air is found in brake fluid.

GI
MA
EM
LC
EC
FE
CL
MT
AT
TF
PD
AX
SU
BR
ST
RS
BT
HA
SC
EL
IDX

CLUTCH MASTER CYLINDER

Components

Components

NACL0006

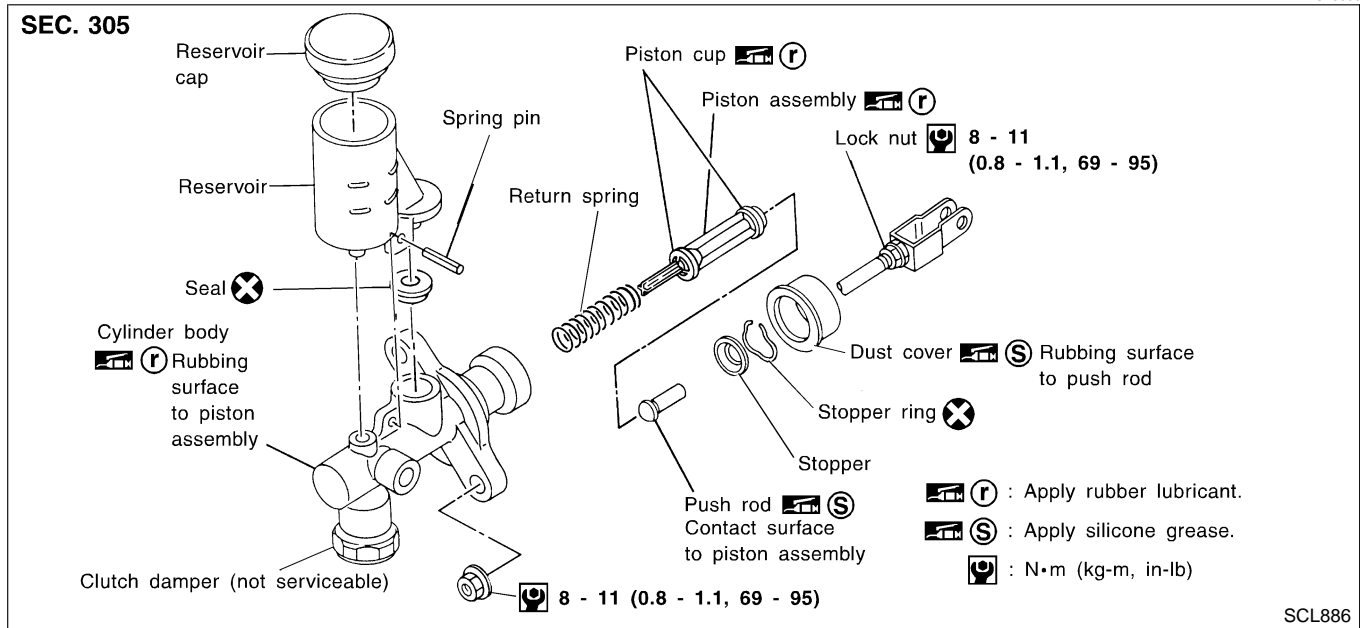

Disassembly and Assembly

NACL0007

- When removing and installing stopper ring, pry it off with screwdriver while pushing push rod into cylinder.

Inspection

NACL0008

Check the following items, and replace if necessary.

- Rubbing surface of cylinder and piston, for uneven wear, rust or damage
- Piston with piston cup, for wear or damage
- Return spring, for wear or damage
- Dust cover, for cracks, deformation or damage
- Reservoir, for deformation or damage

Components

NACL0009

SEC. 306

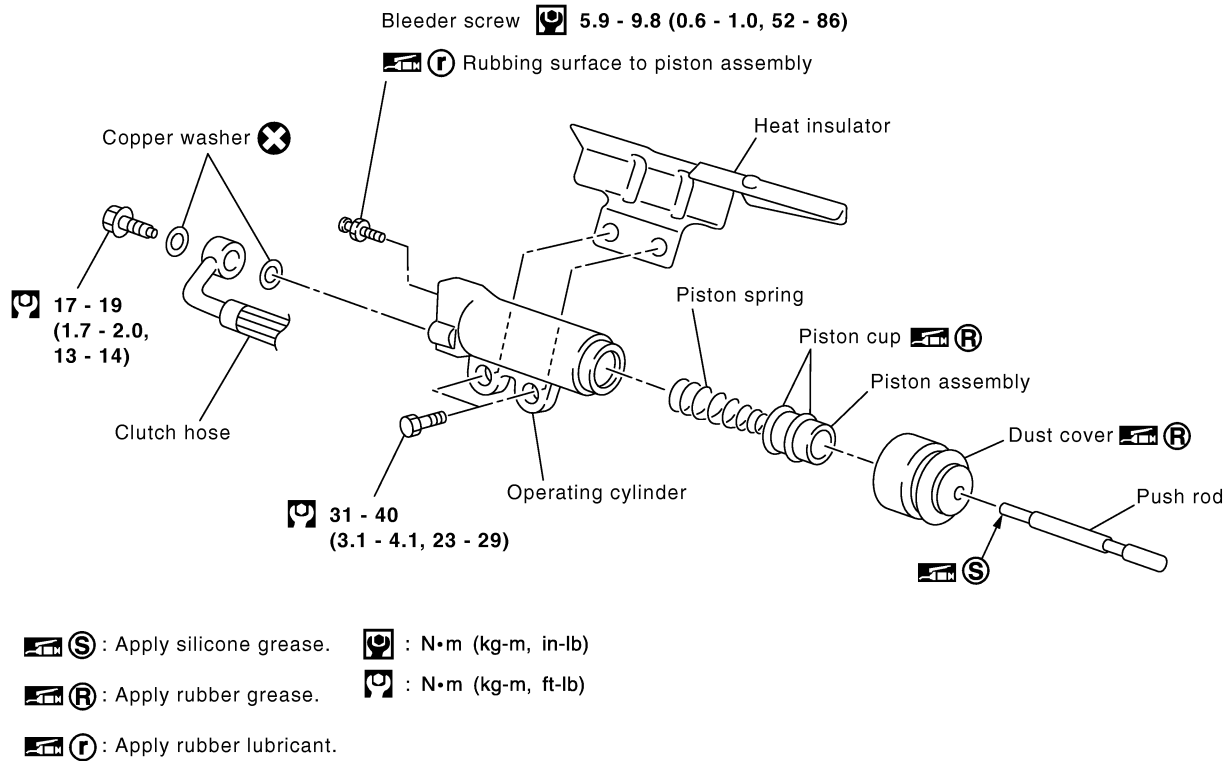

SCL855

Inspection

NACL0010

Check the following items, and replace if necessary.

- Rubbing surface of cylinder and piston, for uneven wear, rust or damage
- Piston with piston cup, for wear or damage
- Piston spring, for wear or damage
- Dust cover, for cracks, deformation or damage

GI
MA
EM
LC
EC
FE
CL
MT
AT
TF
PD
AX
SU
BR
ST
RS
BT
HA
SC
EL
IDX

CLUTCH RELEASE MECHANISM

Components

Components

NACL0013

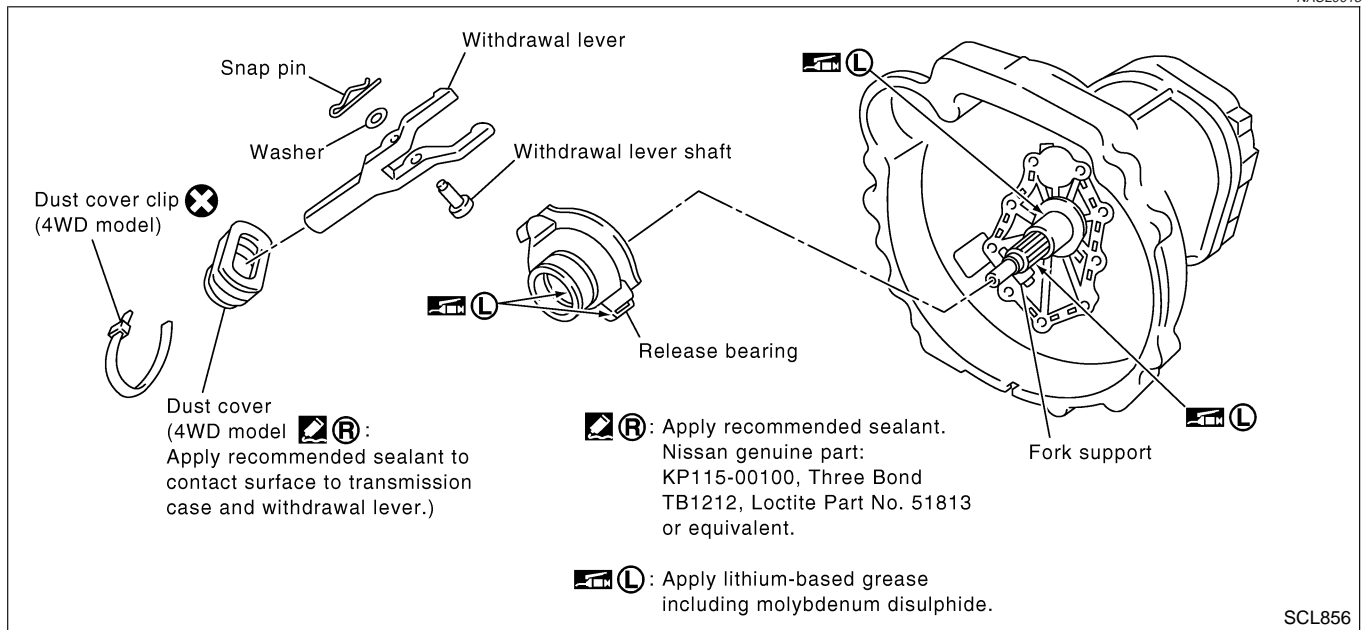

CAUTION:
Keep the clutch disc facing, pressure plate and flywheel free of oil and grease.

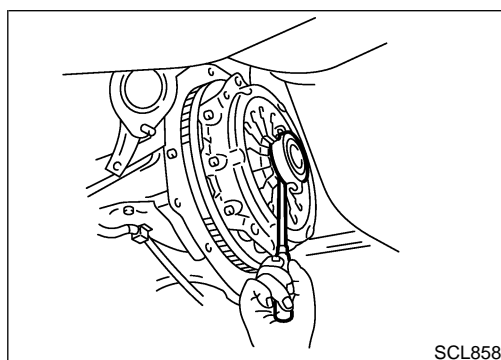
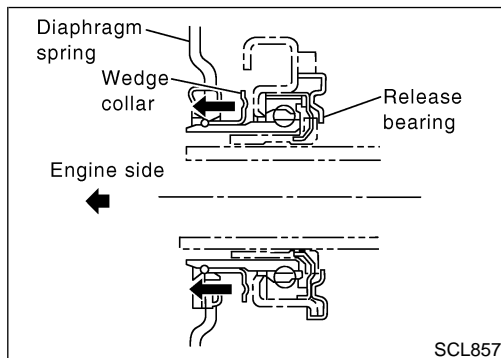

Removal

NACL0029

1. Remove manual transmission from the vehicle. Refer to MT-10, "Removal and Installation".
2. Remove withdrawal lever from inside clutch housing.
3. Press wedge collar on clutch cover toward the engine.
4. Using a flat-head screwdriver or the like, remove release bearing from clutch cover.

CLUTCH RELEASE MECHANISM

Inspection

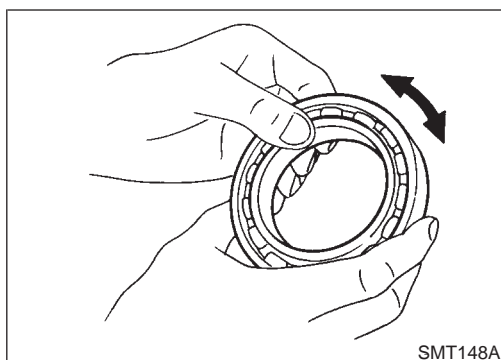

SMT148A

Inspection

NACL0030

Check the following items, and replace the part, if necessary.

- Release bearing seizure, damages, and rough rotation.
- Abnormal wear on contact surfaces of release bearing or withdrawal lever.
- Dust cover cracks.

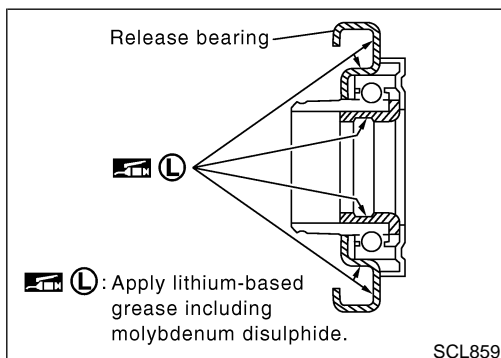

SCL859

Installation

NACL0031

1. Apply clutch sleeve grease to the areas shown by the arrows in the figure.
2. Install the release bearing to main drive shaft.
3. Install withdrawal lever to fork support, and secure it with withdrawal lever shaft, washer, and snap pin.
4. Operate withdrawal lever to check sliding parts for smooth movement.

CAUTION:

Remove excessive grease coming-out.

5. Install manual transmission.
Refer to MT-10, "Removal and Installation".

Lubrication

NACL0016

- Apply recommended grease to contact surface and rubbing surface.
- Too much lubricant might damage clutch disc facing.

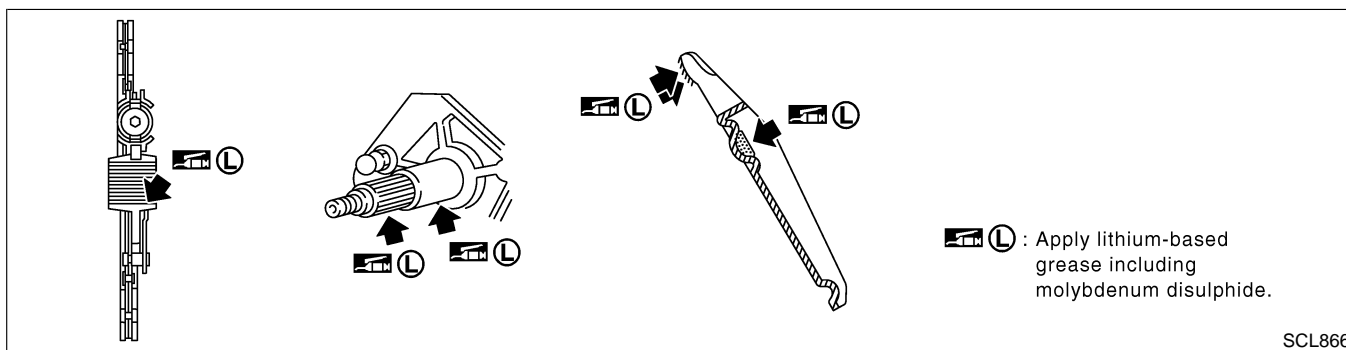

SCL866

GI
MA
EM
LC
EC
FE
CL
MT
AT
TF
PD
AX
SU
BR
ST
RS
BT
HA
SC
EL
IDX

CLUTCH RELEASE MECHANISM

Waterproof — for 4WD Model

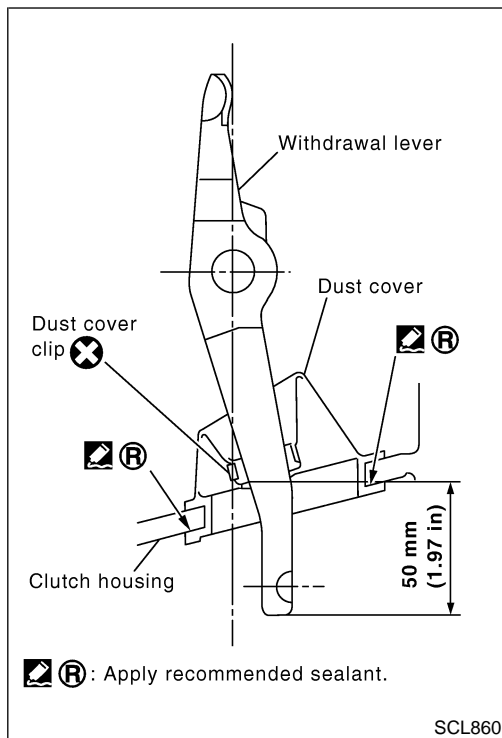

Waterproof — for 4WD Model

NACL0017

- Apply recommended sealant to contact surface of dust cover to transmission case and withdrawal lever and then install dust cover clip.

Recommended sealant: Nissan genuine part KP115-00100, Three Bond TB1212, Loctite Part No. 51813 or equivalent.

Components

NACL0032

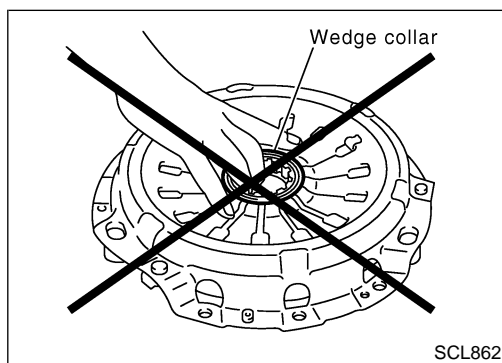
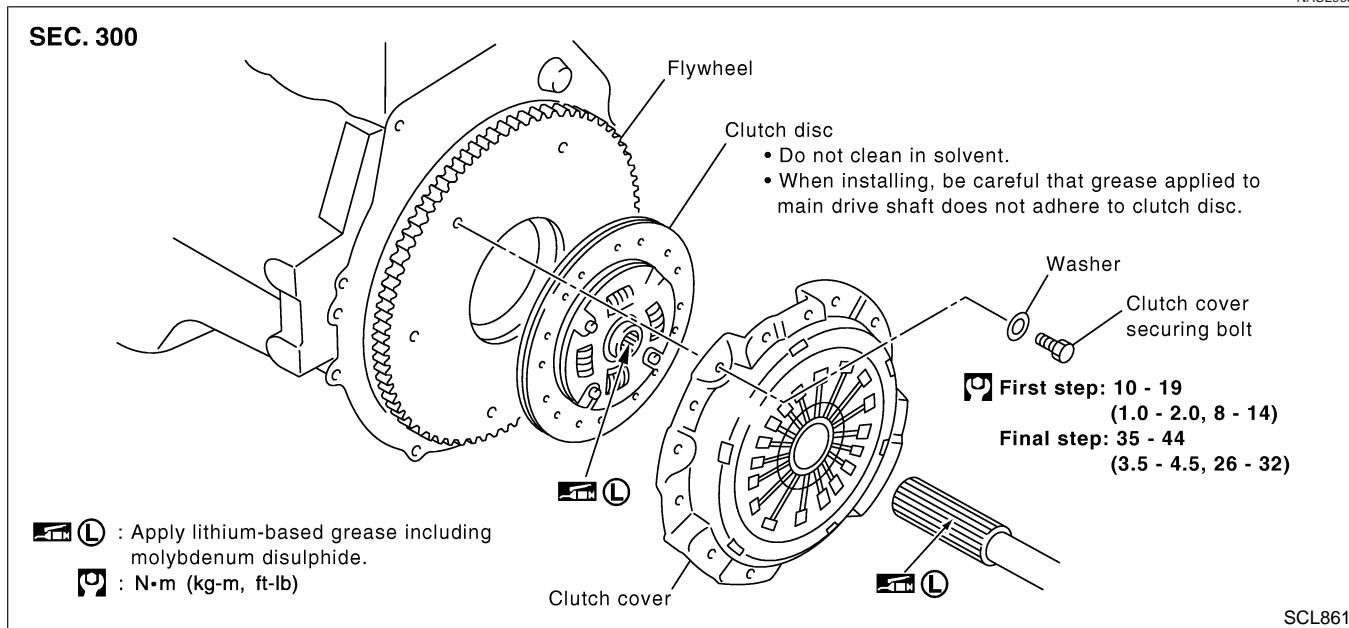

Removal

NACL0033

1. Remove manual transmission from the vehicle. Refer to MT-10, "Removal and Installation".
2. Remove release bearing from clutch cover.
3. Loosen mounting bolts on the clutch cover evenly, and remove clutch cover and clutch disc.

CAUTION:

Do not hold the wedge collar when handling the clutch cover.

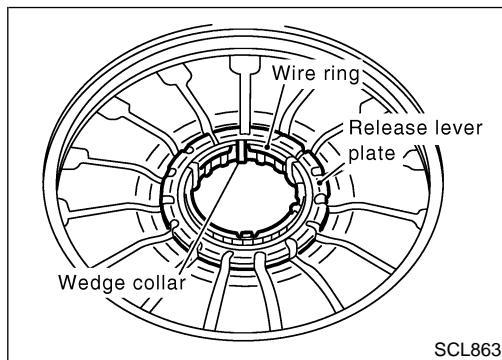

Inspection

NACL0034

- Check parts (wedge collar and wiring) contacting the release bearing. If any worn or damaged parts are found, replace the clutch cover as an assembly.
- Check release lever plate for looseness. If necessary, replace clutch cover as an assembly.
- Check thrust ring of the clutch cover for wear or bending. If necessary, replace clutch cover as an assembly.
- If seizure mark or discoloration is found with the mating surfaces between pressure plate and clutch disc of clutch cover, repair them with sand-paper. If surfaces are distorted or damaged, replace clutch cover as an assembly.

REFERENCE:

- If thrust ring is worn, chattering noise is heard when the riveted area is lightly hit with a hammer.
- If thrust ring is bent, jangling noise is heard when cover is swung up and down.

GI
MA
EM
LC
EC
FE
CL
MT
AT
TF
PD
AX
SU
BR
ST
RS
BT
HA
SC
EL
IDX

CLUTCH DISC, CLUTCH COVER AND FLYWHEEL

Inspection and Adjustment

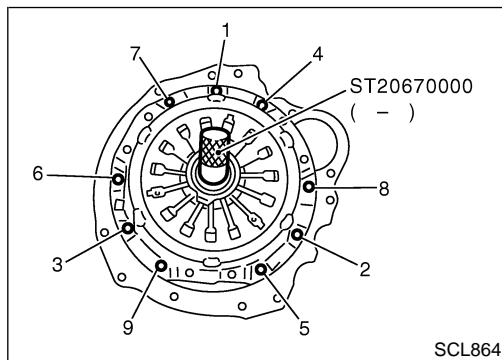
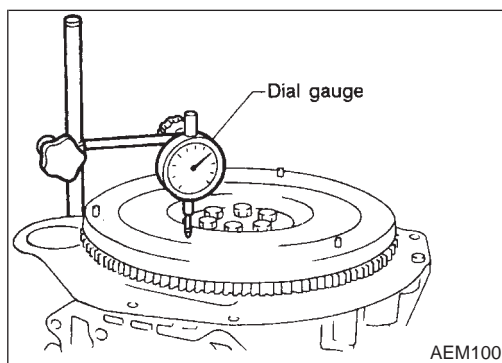
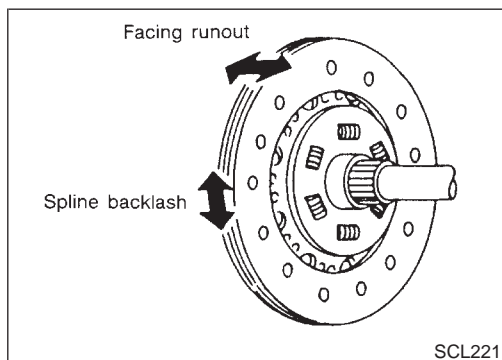
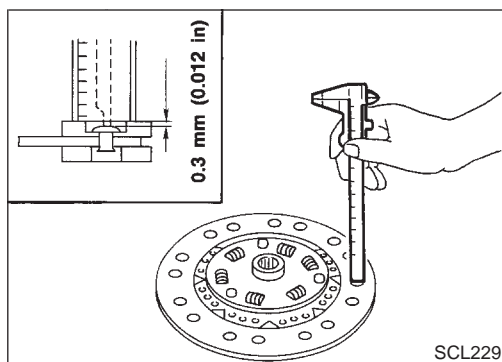

Inspection and Adjustment

NACL0019

CLUTCH DISC

NACL0019S01

Check the following items, and replace if necessary.

- Clutch disc, for burns, discoloration, oil or grease leakage
- Clutch disc, for wear of facing

**Wear limit of facing surface to rivet head:
0.3 mm (0.012 in)**

- Clutch disc, for backlash of spline and runout of facing
**Maximum backlash of spline (at outer edge of disc):
1.0 mm (0.039 in)**
**Runout limit:
Less than 0.7 mm (0.028 in)**
**Distance of runout check point (from hub center):
120 mm (4.72 in)**

FLYWHEEL INSPECTION

NACL0019S03

CAUTION:

Do not allow any magnetic materials to contact the ring gear teeth.

- Inspect contact surface of flywheel for slight burns or discoloration. Clean flywheel with emery paper.
- Check flywheel runout.

**Maximum allowable runout:
Refer to EM-71, "Flywheel/Drive plate Runout".**

Installation

NACL0035

1. Apply specified Nissan clutch grease to clutch disc and spline of main drive shaft.

CAUTION:

Always apply grease. If no grease is applied, it may cause abnormal noise, insufficient disengagement, or damage to the clutch. Also, always remove excessive grease. If grease is applied excessively, it may cause sliding or juddering.

2. Install clutch disc and clutch cover. Tighten mounting bolts temporarily, and install clutch aligning bar (SST).

CLUTCH DISC, CLUTCH COVER AND FLYWHEEL

Installation (Cont'd)

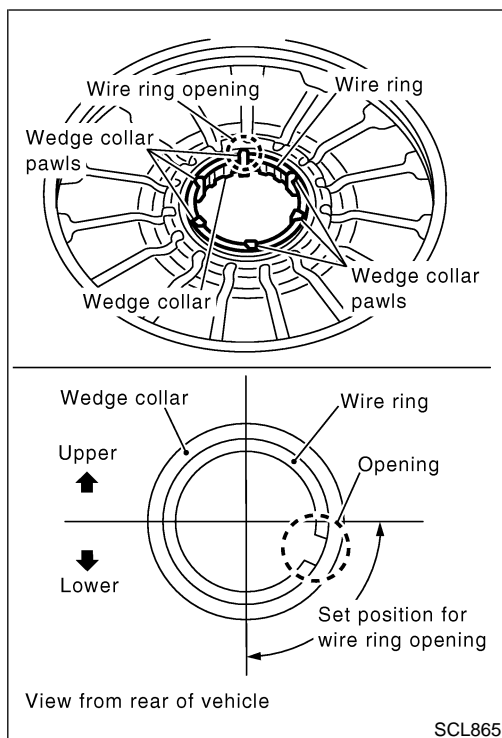

3. Tighten clutch cover mounting bolts evenly in the order shown in the figure by two steps.

1st step:

 : 10 - 19 N·m (1.0 - 2.0 kg·m, 8 - 14 ft·lb)

Final step:

 : 35 - 44 N·m (3.5 - 4.5 kg·m, 26 - 32 ft·lb)

4. Check that the wire ring of clutch cover is installed securely to wedge collar pawls.
5. Turn flywheel so that the wire ring opening is positioned as shown in the figure.

CAUTION:

Always perform alignment of the wire ring opening. If transmission is installed without alignment, it may cause clutch disengagement failure or clutch pedal operation failure.

6. Install manual transmission.
Refer to MT-10, "Removal and Installation".

GI

MA

EM

LC

EC

FE

CL

MT

AT

TF

PD

AX

SU

BR

ST

RS

BT

HA

SC

EL

IDX

SERVICE DATA AND SPECIFICATIONS (SDS)

Clutch Control System

Clutch Control System

NACL0028

Type of clutch control	Hydraulic
------------------------	-----------

Clutch Master Cylinder (With damper)

NACL0021

Inner diameter	15.87 mm (5/8 in)
----------------	-------------------

Clutch Operating Cylinder

NACL0022

Inner diameter	19.05 mm (3/4 in)
----------------	-------------------

Clutch Disc

NACL0023
Unit: mm (in)

Model	250
Facing size (Outer dia. x inner dia. x thickness)	250 × 160 × 3.5 (9.84 × 6.30 × 0.138)
Thickness of disc assembly With load	7.9 - 8.3 (0.311 - 0.327) with 7,355 N (750 kg, 1,654 lb)
Wear limit of facing surface to rivet head	0.3 (0.012)
Runout limit of facing	0.7 (0.028)
Distance of runout check point (from hub center)	120 (4.72)
Maximum backlash of spline (at outer edge of disc)	1.0 (0.039)

Clutch Cover

NACL0024
Unit: mm (in)

Model	250
Set-load	7,355 N (750 kg, 1,654 lb)
Diaphragm spring height	48.2 - 50.2 (1.898 - 1.976)
Uneven limit of diaphragm spring toe height	0.6 (0.024)

Clutch Pedal

NACL0025
Unit: mm (in)

Pedal height "H"	186 - 196 (7.32 - 7.72)
Pedal free play "A" (at pedal pad)	9 - 16 (0.35 - 0.63)
Clearance between pedal stopper bracket and threaded end of clutch interlock switch (when depressing clutch pedal fully.)	0.1 - 1.5 (0.004 - 0.059)

*: Measured from surface of dash lower panel to pedal pad.