

ACCELERATOR CONTROL, FUEL & EXHAUST SYSTEMS

GI

MA

EM

LC

EC

FE

CL

MT

AT

TF

PD

AX

SU

BR

ST

RS

BT

HA

SC

EL

IDX

SECTION FE

CONTENTS

| | | | |
|---|---|--|---|
| PREPARATION | 2 | FUEL SYSTEM | 4 |
| Special Service Tool | 2 | Removal and Installation | 4 |
| Commercial Service Tools | 2 | FUEL TANK | 5 |
| ACCELERATOR CONTROL SYSTEM | 3 | FUEL PUMP AND FUEL LEVEL SENSOR UNIT | 6 |
| Removal and Installation | 3 | EXHAUST SYSTEM | 8 |
| Adjusting Accelerator Wire | 3 | Removal and Installation | 8 |

PREPARATION

Special Service Tool

Special Service Tool

NAFE0001

The actual shapes of Kent-Moore tools may differ from those of special service tools illustrated here.

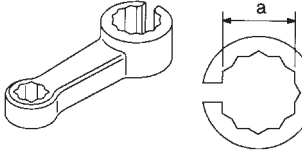
| Tool number (Kent-Moore No.) Tool name | Description |
|--|--|
| KV10114400 (J38365) Heated oxygen sensor wrench |  <p>Loosening or tightening rear heated oxygen sensor (For right bank) a: 22 mm (0.87 in)</p> <p>NT636</p> |

Commercial Service Tools

NAFE0007

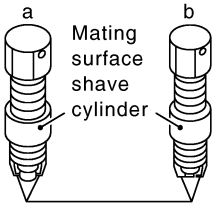
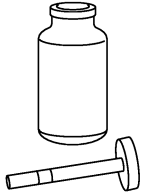
| Tool number (Kent-Moore No.) Tool name | Description |
|--|---|
| Oxygen sensor thread cleaner (J-43897-18) (J-43897-12) |  <p>Reconditioning the exhaust system threads before installing a new oxygen sensor. Use with anti-seize lubricant shown below.</p> <p>a: J-43897-18 (18 mm dia.) for Zirconia Oxygen Sensor b: J-43897-12 (12 mm dia.) for Titania Oxygen Sensor</p> <p>NT778</p> |
| Anti-seize lubricant (Permatex™ 133AR or equivalent meeting MIL specification MIL-A-907) |  <p>Lubricating oxygen sensor thread cleaning tool when reconditioning exhaust system threads.</p> <p>NT779</p> |

Removal and Installation

NAFE0002

CAUTION:

- When removing accelerator wire, make a mark to indicate lock nut's initial position.
- Check that throttle valve opens fully when accelerator pedal is fully depressed. Also check that it returns to idle position when pedal is released.
- Check accelerator control parts for improper contact with any adjacent parts.
- When connecting accelerator wire, be careful not to twist or scratch its inner wire.
- Refer to EL-236, "AUTOMATIC SPEED CONTROL DEVICE" for ASCD wire adjustment.

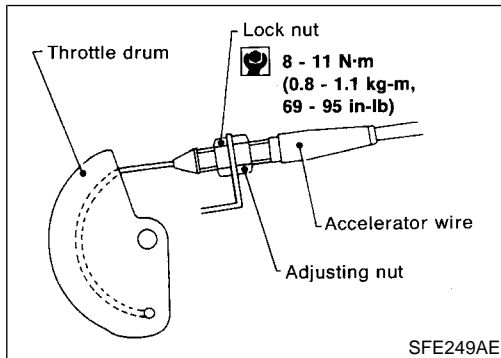
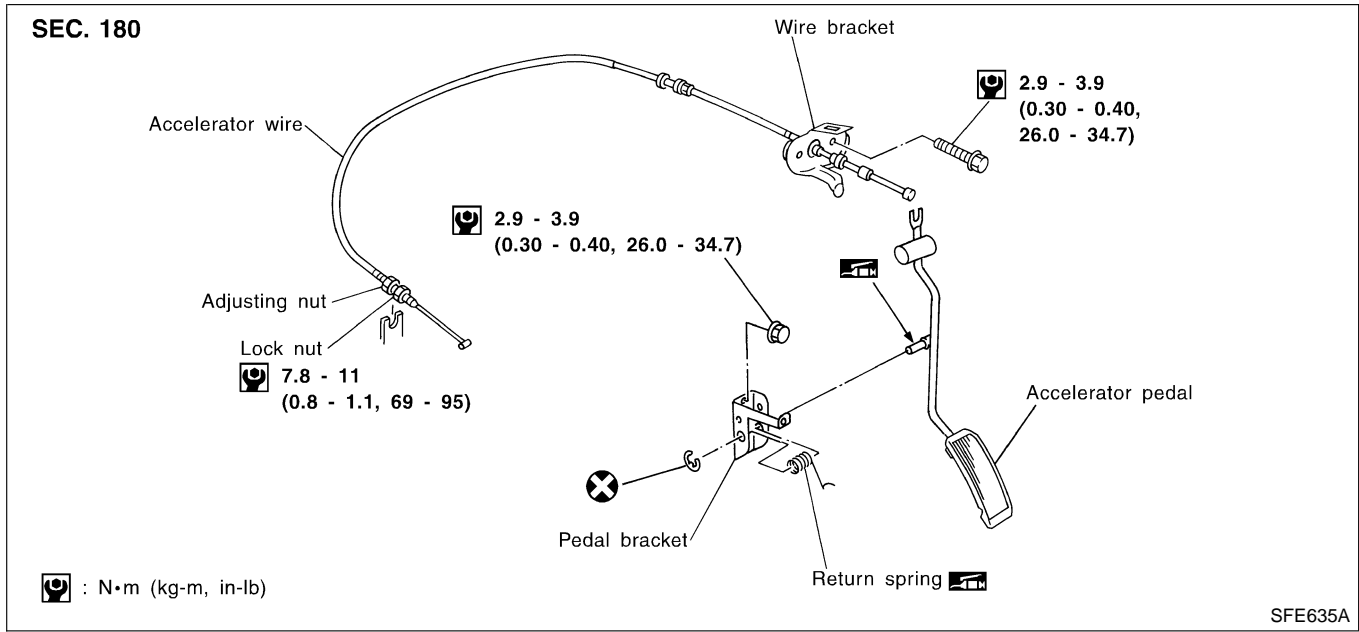

Adjusting Accelerator Wire

NAFE0003

1. Loosen lock nut.
2. Tighten accelerator adjusting nut until throttle drum starts to move.
3. From that position, turn back adjusting nut 1.5 to 2 turns, and secure lock nut.

GI
MA
EM
LC
EC
FE
CL
MT
AT
TF
PD
AX
SU
BR
ST
RS
BT
HA
SC
EL
IDX

Removal and Installation

NAFE0004

WARNING:

When replacing fuel line parts, be sure to observe the following:

- Put a “CAUTION: INFLAMMABLE” sign in workshop.
- Do not smoke while servicing fuel system. Keep open flames and sparks away from work area.
- Be sure to furnish the workshop with a CO₂ fire extinguisher.

CAUTION:

- Before removing fuel line parts, carry out the following procedures:
 - a) Put drained fuel in an explosion-proof container and put lid on securely.
 - b) Release fuel pressure from fuel line. Refer to MA-17, “Changing Fuel Filter”.
 - c) Disconnect battery ground cable.
- Always replace O-ring with new ones.
- Do not kink or twist hose and tube when they are installed.
- Do not tighten hose clamps excessively to avoid damaging hoses.
- When installing fuel check valve, be careful of its designated direction. Refer to EC-33, “EVAPORATIVE EMISSION SYSTEM”.
- After installation, run engine and check for fuel leaks at connections.

FUEL SYSTEM

Removal and Installation (Cont'd)

SEC. 172

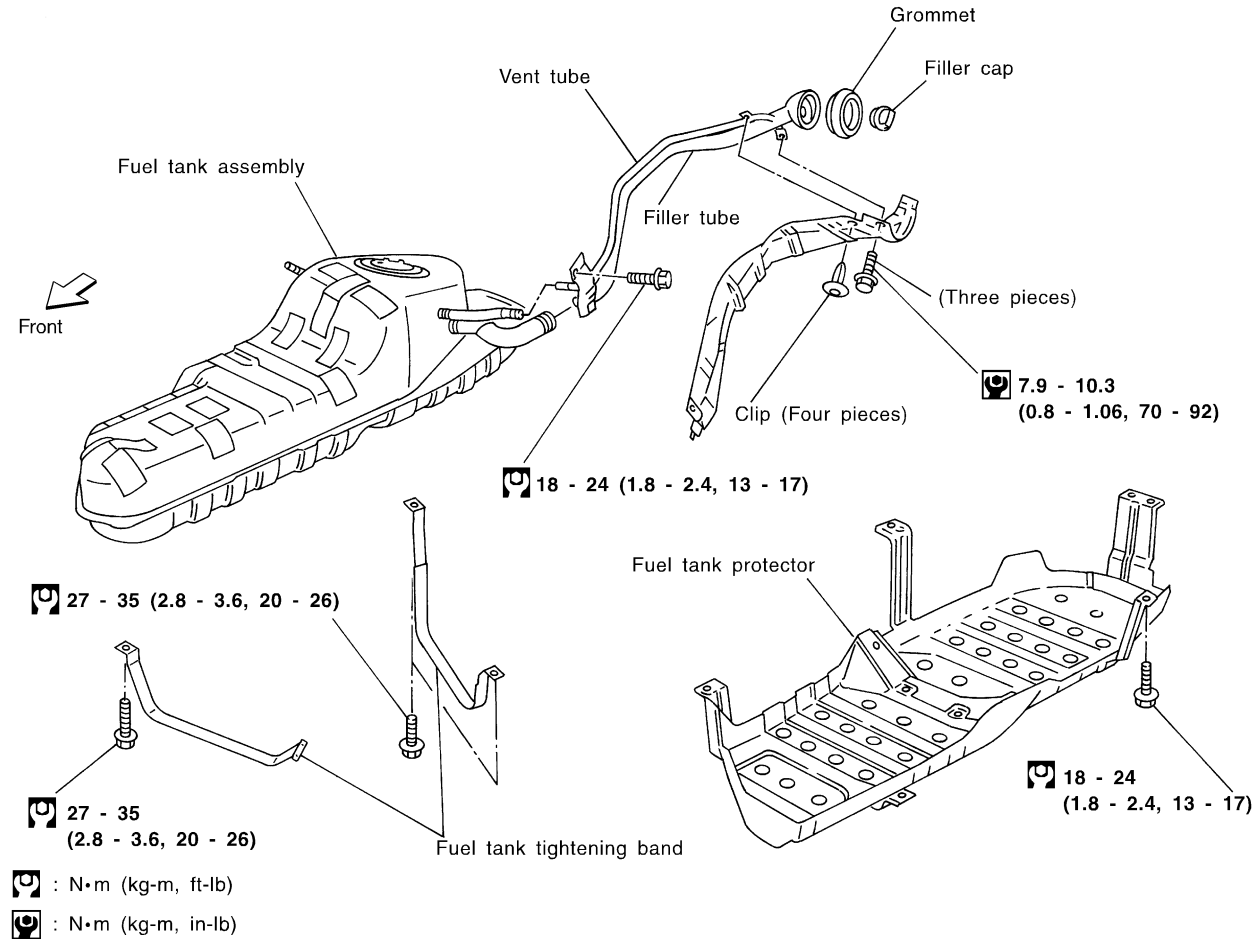

SFE419AA

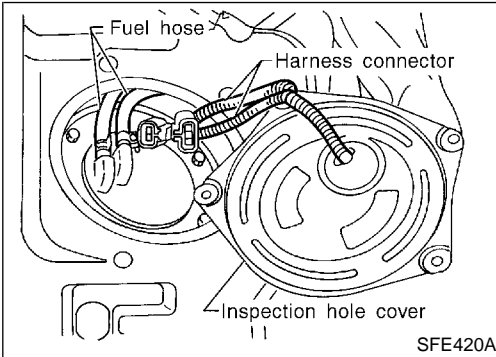

FUEL TANK

NAFE0004S01

1. Release fuel pressure from fuel line. Refer to MA-17, "Changing Fuel Filter".
2. Remove inspection hole cover located behind the rear seat.
3. Disconnect harness connectors under inspection hole cover.
4. Disconnect fuel hoses.
 - Put mating marks on hoses for correct installation.
5. Disconnect filler hose, vent hose and evaporation hose at fuel tank side.

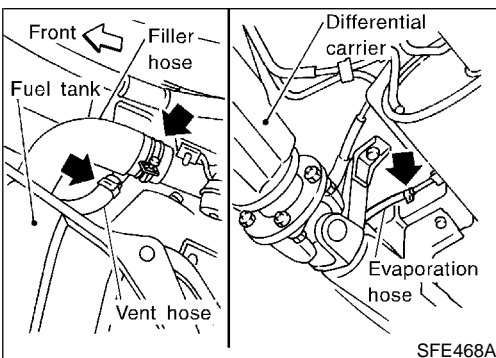

GI
MA
EM
LC
EC
FE
CL
MT
AT
TF
PD
AX
SU
BR
ST
RS
BT
HA
SC
EL
IDX

FUEL SYSTEM

Removal and Installation (Cont'd)

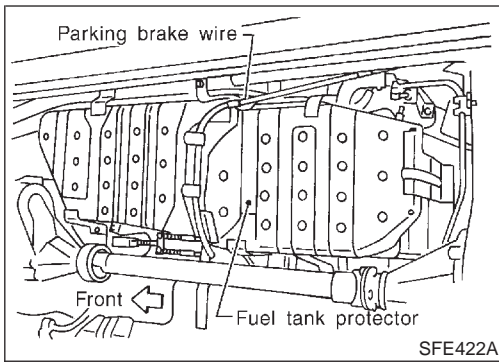

6. Remove parking brake wire from fuel tank protector.
7. Remove fuel tank protector.

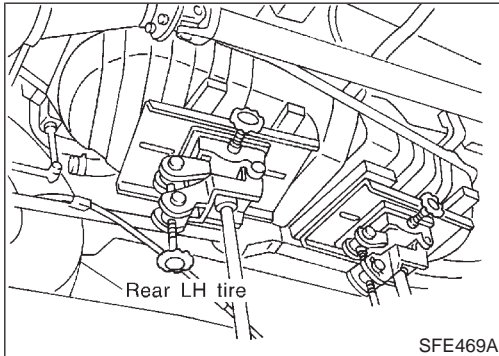

8. Remove fuel tank band mounting bolts while supporting fuel tank.
9. Remove fuel tank.

Installation procedure is the reverse order of removal.

FUEL PUMP AND FUEL LEVEL SENSOR UNIT

NAFE0004S02

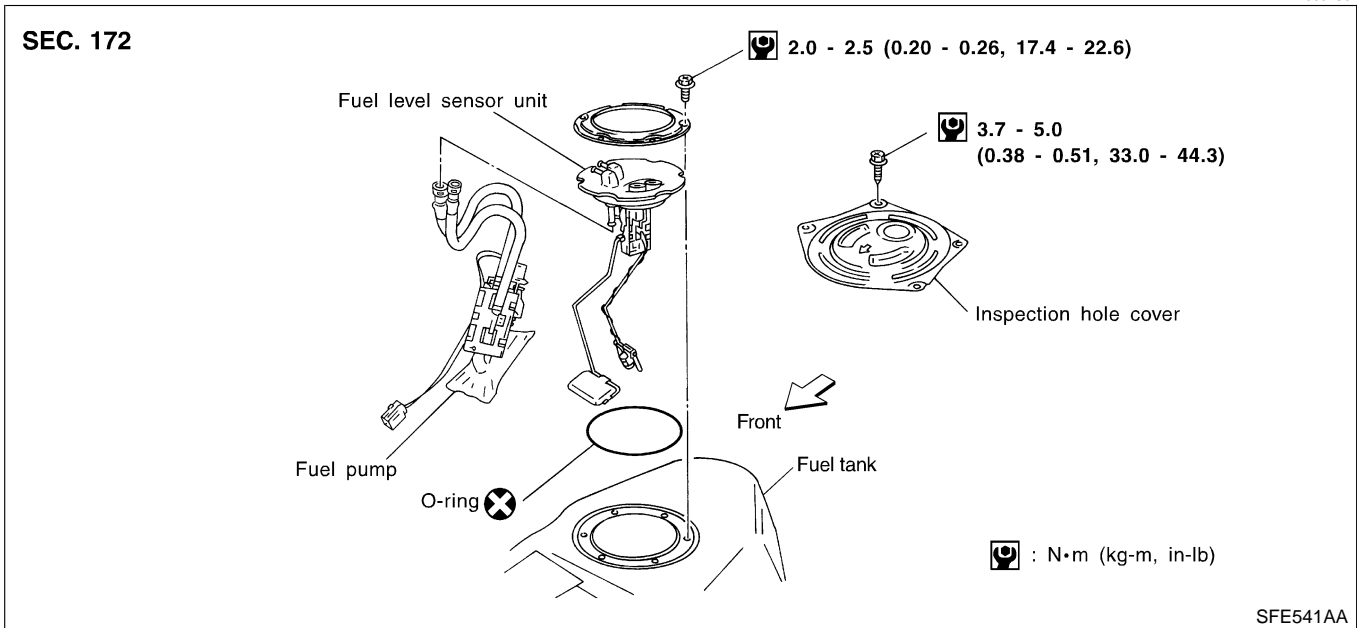

1. Release fuel pressure from fuel line. Refer to MA-17, "Changing Fuel Filter".
2. Remove inspection hole cover located behind the rear seat.
3. Disconnect harness connectors and fuel tubes from upper plate of fuel level sensor unit.
 - Put mating marks on tubes for correct installation.
4. Remove fuel level sensor unit retainer and fuel level sensor unit.

FUEL SYSTEM

Removal and Installation (Cont'd)

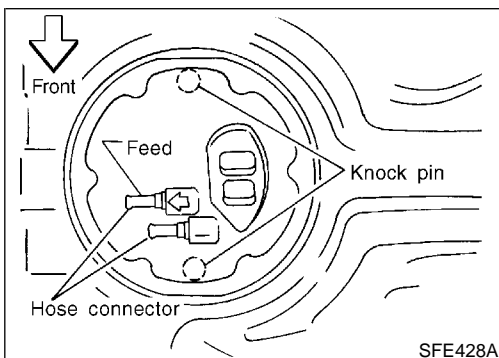
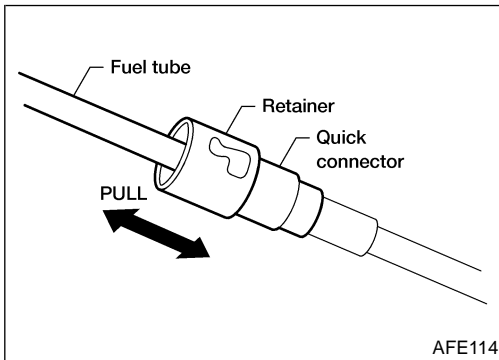
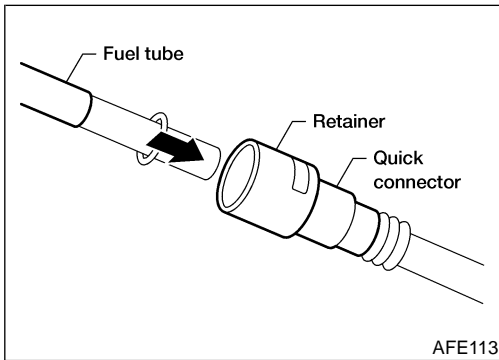
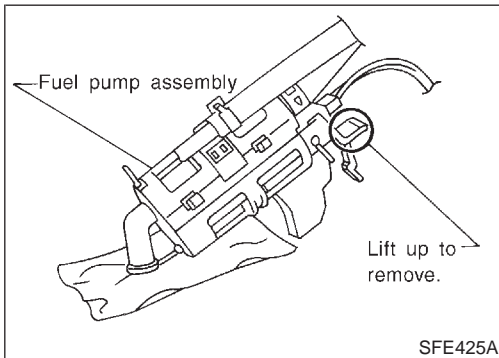
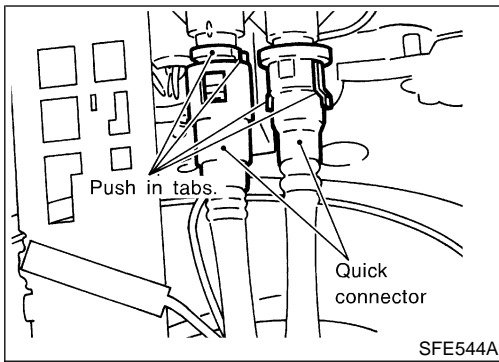

5. Disconnect the quick connectors as follows.
 - 1) Put mating marks on tubes and connectors for correct installation.
 - 2) Hold the sides of the connector, push in tabs, and pull out the tube inserted in the retainer.

CAUTION:

- The tube can be removed when the push in tabs are completely depressed. Do not twist it more than necessary.
 - Do not use any tools to remove the quick connector.
 - Keep the connecting portion of the tubes and quick connectors clean.
6. Remove fuel pump with bracket while lifting the pawl of the fuel pump bracket upward.

7. To install, reverse the removal procedure. Connect the quick connectors as follows.
 - Be sure that the connecting portion is clean and smooth.
 - Align mating marks.
 - Insert tube into the center of the connector until you hear a click.

After connecting quick connectors, make sure the connection is firmly made using the following method.

- Pull on the fuel tube and connector to make sure they are firmly connected.
- Start the engine, increase engine speed and verify that there are no leaks.

- Install fuel level sensor unit as shown.

GI
MA
EM
LC
EC
FE
CL
MT
AT
TF
PD
AX
SU
BR
ST
RS
BT
HA
SC
EL
IDX

EXHAUST SYSTEM

Removal and Installation

Removal and Installation

NAFE0005

CAUTION:

- Always replace exhaust gaskets with new ones when reassembling.
- With engine running, check all tube connections for exhaust gas leaks, and entire system for unusual noises.
- Check to ensure that mounting brackets and mounting insulators are installed properly and free from undue stress. Improper installation could result in excessive noise or vibration.
- Discard any heated oxygen sensor which has been dropped from a height of more than 0.5 m (19.7 in) onto a hard surface such as a concrete floor; use a new one.
- Before installing new oxygen sensor, clean exhaust system threads using Oxygen Sensor Thread Cleaner tool J-43897-18 or J-43897-12 and approved anti-seize lubricant.
- Do not overtorque the oxygen sensor. Doing so may cause damage to the oxygen sensor, resulting in the MIL coming on.

EXHAUST SYSTEM

Removal and Installation (Cont'd)

SEC. 200•208
4WD model

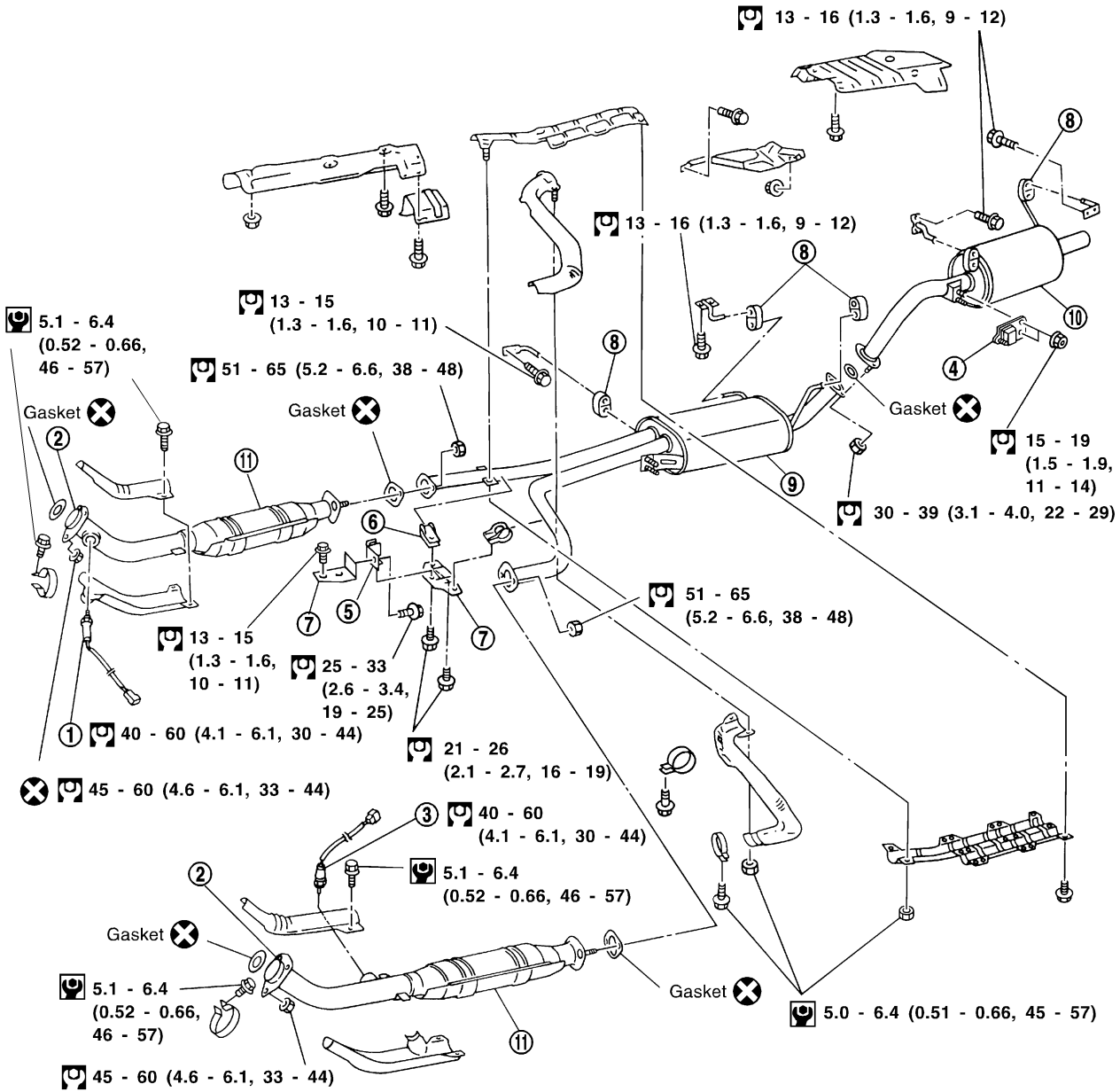

* : Part-time 4WD models only

: N·m (kg-m, in-lb)

: N·m (kg-m, ft-lb)

SFE684A

1. Heated oxygen sensor 2 (rear) (bank 1)
2. Front tube
3. Heated oxygen sensor 2 (rear) (bank 2)

4. Dynamic damper
5. Mounting rubber
6. Clamp
7. Mounting bracket

8. Mounting rubber
9. Main muffler
10. Post muffler
11. TWC (under floor)

GI
MA
EM
LC
EC
FE
CL
MT
AT
TF
PD
AX
SU
BR
ST
RS
BT
HA
SC
EL
IDX

EXHAUST SYSTEM

Removal and Installation (Cont'd)

SEC. 200•208
2WD model

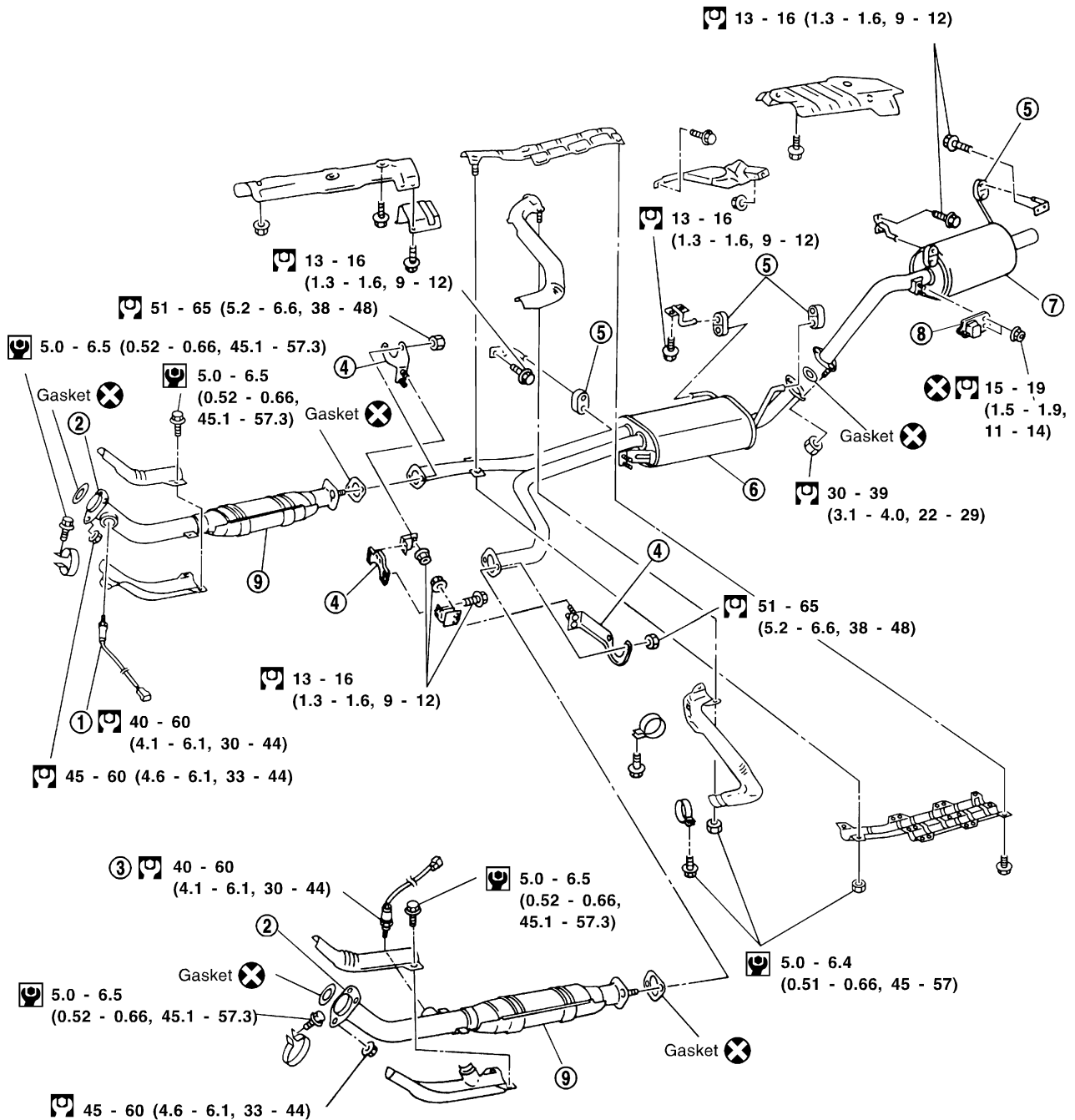

: N•m (kg-m, in-lb)

: N•m (kg-m, ft-lb)

SFE683A

1. Heated oxygen sensor 2 (rear) (bank 1)
2. Front tube
3. Heated oxygen sensor 2 (rear) (bank 2)

4. Mounting bracket
5. Mounting rubber
6. Main muffler

7. Post muffler
8. Dynamic damper
9. TWC (under floor)