

STEERING SYSTEM

SECTION ST

GI
MA
EM
LC
EC
FE
CL
MT
AT
TF
PD
AX
SU
BR
ST
RS
BT
HA
SC
EL
IDX

CONTENTS

PRECAUTIONS	2	TILT MECHANISM	14
Supplemental Restraint System (SRS) "AIR BAG" and "SEAT BELT PRE-TENSIONER"	2	STEERING TRANSFER GEAR	15
Precautions for Steering System	2	Removal	15
PREPARATION	3	Installation	16
Special Service Tools	3	Inspection	16
Commercial Service Tools	4	POWER STEERING GEAR AND LINKAGE	17
NOISE, VIBRATION AND HARSHNESS (NVH)		Components	17
TROUBLESHOOTING	6	Removal and Installation	18
NVH Troubleshooting Chart	6	Disassembly	19
ON-VEHICLE SERVICE	7	Inspection	20
Checking Steering Wheel Play	7	BOOT	20
Checking Neutral Position on Steering Wheel	7	RACK	20
PRE-CHECKING	7	PINION ASSEMBLY	20
CHECKING	7	GEAR HOUSING CYLINDER	20
Front Wheel Turning Angle	7	TIE-ROD OUTER AND INNER SOCKETS	21
Checking Gear Housing Movement	8	Assembly	21
Adjusting Rack Retainer	8	Adjustment	24
Checking and Adjusting Drive Belts	8	POWER STEERING OIL PUMP	27
Checking Fluid Level	8	Components	27
Checking Fluid Leakage	8	Pre-disassembly Inspection	27
Bleeding Hydraulic System	9	Disassembly	28
Checking Steering Wheel Turning Force	9	Inspection	29
Checking Hydraulic System	10	Assembly	29
STEERING WHEEL AND STEERING COLUMN	11	SERVICE DATA AND SPECIFICATIONS (SDS)	32
Components	11	General Specifications	32
Removal and Installation	11	Steering Wheel	32
STEERING WHEEL	11	Steering Column	32
STEERING COLUMN	12	Steering Transfer Gear	32
Disassembly and Assembly	13	Steering Gear and Linkage	33
Inspection	14	Power Steering	33

PRECAUTIONS

Supplemental Restraint System (SRS) "AIR BAG" and "SEAT BELT PRE-TENSIONER"

Supplemental Restraint System (SRS) "AIR BAG" and "SEAT BELT PRE-TENSIONER"

NAST0045

The Supplemental Restraint System such as "AIR BAG" and "SEAT BELT PRE-TENSIONER" used along with a seat belt, helps to reduce the risk or severity of injury to the driver and front passenger for certain types of collision. The SRS system composition which is available to NISSAN MODEL R50 is as follows:

- For a frontal collision
The Supplemental Restraint System consists of driver air bag module (located in the center of the steering wheel), front passenger air bag module (located on the instrument panel on passenger side), seat belt pre-tensioners, a diagnosis sensor unit, warning lamp, wiring harness and spiral cable.
- For a side collision
The Supplemental Restraint System consists of side air bag module (located in the outer side of front seat), satellite sensor, diagnosis sensor unit (one of components of air bags for a frontal collision), wiring harness, warning lamp (one of components of air bags for a frontal collision).

Information necessary to service the system safely is included in the **RS section** of this Service Manual.

WARNING:

- To avoid rendering the SRS inoperative, which could increase the risk of personal injury or death in the event of a collision which would result in air bag inflation, all maintenance must be performed by an authorized NISSAN dealer.
- Improper maintenance, including incorrect removal and installation of the SRS, can lead to personal injury caused by unintentional activation of the system. For removal of Spiral Cable and Air Bag Module, see the RS section.
- Do not use electrical test equipment on any circuit related to the SRS unless instructed to in this Service Manual. Spiral cable and wiring harnesses covered with yellow insulation type either just before the harness connectors or for the complete harness are related to the SRS.

Precautions for Steering System

NAST0046

- Before disassembly, thoroughly clean the outside of the unit.
- Disassembly should be done in a clean work area. It is important to prevent the internal parts from becoming contaminated by dirt or other foreign matter.
- Place disassembled parts in order, on a parts rack, for easier and proper assembly.
- Use nylon cloths or paper towels to clean the parts; common shop rags can leave lint that might interfere with their operation.
- Before inspection or reassembly, carefully clean all parts with a general purpose, non-flammable solvent.
- Before assembly, apply a coat of recommended power steering fluid* to hydraulic parts. Vaseline may be applied to O-rings and seals. Do not use any grease.
- Replace all gaskets, seals and O-rings. Avoid damaging O-rings, seals and gaskets during installation. Perform functional tests whenever designated.

*: Genuine Nissan PSF II or equivalent. Refer to MA-12, "Fluids and Lubricants".

PREPARATION

Special Service Tools

Special Service Tools

MAST0003

The actual shapes of Kent-Moore tools may differ from those of special service tools illustrated here.

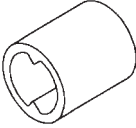
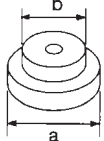
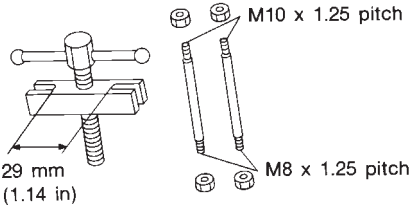
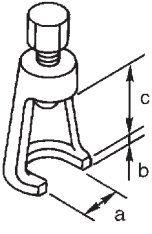
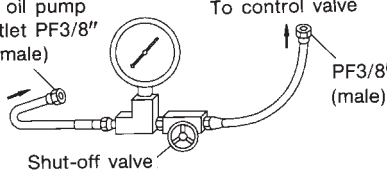
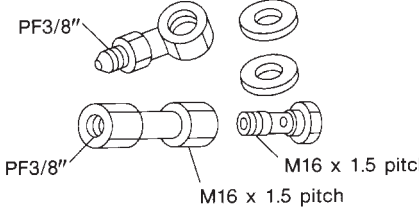
Tool number (Kent-Moore No.) Tool name	Description	
KV48100700 (J26364) Torque adapter		Measuring pinion rotating torque
ST35300000 (—) Drift		Installing power steering oil pump oil seal a: 59 mm (2.32 in) dia. b: 45 mm (1.77 in) dia.
ST27180001 (J25726-A) Steering wheel puller		Removing steering wheel
ST29020001 (J24319-01) Ball joint remover		Removing ball joint a: 34 mm (1.34 in) b: 6.5 mm (0.256 in) c: 61.5 mm (2.421 in)
KV48103500 (J26357 and J26357-10) Pressure gauge		Measuring oil pressure
KV48102500 (—) Pressure gauge adapter		Measuring oil pressure

GI
MA
EM
LC
EC
FE
CL
MT
AT
TF
PD
AX
SU
BR
ST
RS
BT
HA
SC
EL
IDX

PREPARATION

Special Service Tools (Cont'd)

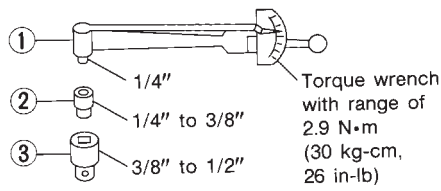
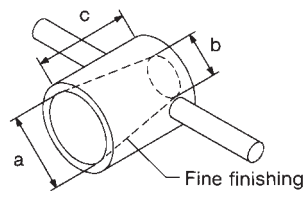
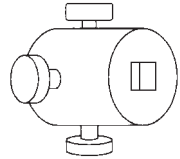
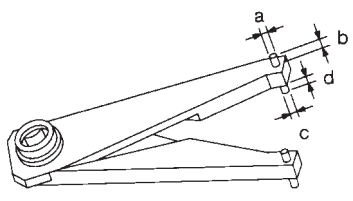
Tool number (Kent-Moore No.) Tool name	Description	
ST3127S000 (See J25765-A) 1 GG91030000 (J25765-A) Torque wrench 2 HT62940000 (—) Socket adapter 3 HT62900000 (—) Socket adapter	 <p>NT541</p>	Measuring turning torque
KV48104400 (—) Rack seal ring reformer	 <p>NT550</p>	Reforming teflon ring a: 50 mm (1.97 in) dia. b: 36 mm (1.42 in) dia. c: 100 mm (3.94 in)
KV48103400 (—) Torque adapter	 <p>NT236</p>	Measuring steering transfer gear rotating torque
KV48104200 (—) Rear cover wrench	 <p>NT540</p>	Removing and installing gear housing end cover a: 4 mm (0.16 in) dia. b: 5 mm (0.20 in) c: 3 mm (0.12 in) dia. d: 5 mm (0.20 in)

Commercial Service Tools

NAST0004

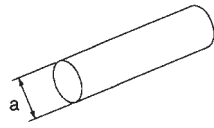
Tool name	Description	
Rear oil seal drift	 <p>NT063</p>	Installing rear oil seal a: 28 mm (1.10 in) dia.

PREPARATION

Commercial Service Tools (Cont'd)

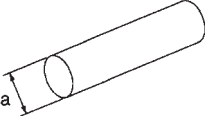
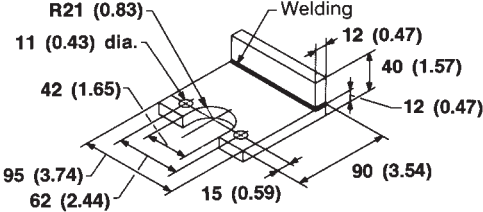
Tool name	Description	
Pinion oil seal drift	 <p>Installing pinion oil seal a: 40 mm (1.57 in) dia.</p> <p>NT063</p>	GI MA EM
Oil pump attachment	 <p>Disassembling and assembling oil pump Unit: mm (in)</p> <p>NT179</p>	LC EC FE CL MT AT TF PD AX SU BR

ST

RS

BT

HA

SC

EL

IDX

NOISE, VIBRATION AND HARSHNESS (NVH) TROUBLESHOOTING

NVH Troubleshooting Chart

NVH Troubleshooting Chart

NA5T0043/07

Use the chart below to help you find the cause of the symptom. If necessary, repair or replace these parts.

Reference page	Possible cause and SUSPECTED PARTS				
	STEERING	Noise	Shake	Vibration	Judder
ST-8		×			
ST-9		×			
ST-21		×			
ST-21		×			
ST-21		×			
ST-8		×			
ST-7		×			
ST-9		×			
MA-14		×			
—			×	×	
ST-13			×	×	
ST-8	×	×	×	×	
ST-13			×		
ST-13			×		
ST-17	×	×			
PD-4			×	×	×
PD-4					×
AX-3			×	×	×
AX-3	×	×	×	×	×
SU-3	×	×	×	×	×
SU-3	×	×	×	×	×
SU-3	×	×		×	×
BR-7	×	×		×	×

x: Applicable

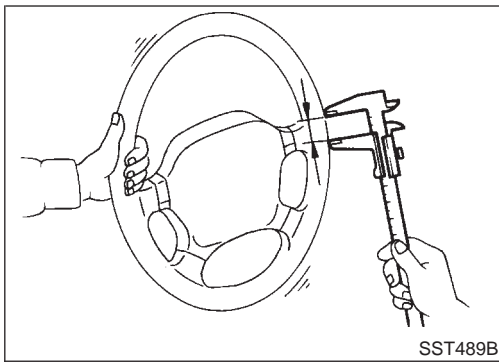

Checking Steering Wheel Play

NAST0005

1. With wheels in a straight-ahead position, check steering wheel play.

Steering wheel play:
35 mm (1.38 in) or less

2. If it is not within specification, check the following for loose or worn components.

Steering gear assembly
Steering column
Front suspension and axle

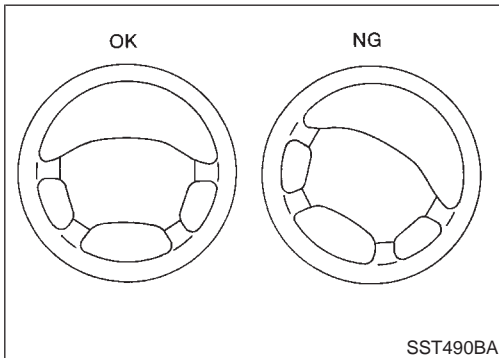

Checking Neutral Position on Steering Wheel

NAST0006

PRE-CHECKING

NAST0006S01

- Make sure that wheel alignment is correct.

Wheel alignment:
Refer to SU-14, "Wheel Alignment".

- Verify that the steering gear is centered before removing the steering wheel.

CHECKING

NAST0006S02

1. Check that the steering wheel is in the neutral position when driving straight ahead.
2. If it is not in the neutral position, remove the steering wheel and reinstall it correctly.
3. If the neutral position is between two teeth, loosen tie-rod lock nuts. Turn the tie-rods by the same amount in opposite directions on both left and right sides.

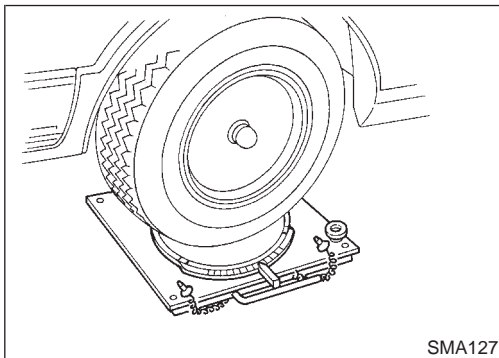

Front Wheel Turning Angle

NAST0007

1. Rotate steering wheel all the way right and left; measure turning angle.

Turning angle of full turns:
Refer to SU-14, "Wheel Alignment".

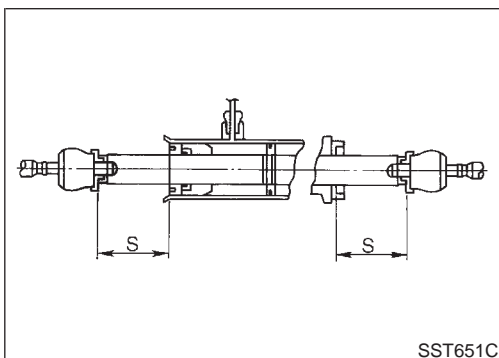

2. If it is not within specification, check rack stroke.

Rack stroke "S":
Refer to SDS (ST-33).

GI
 MA
 EM
 LC
 EC
 FE
 CL
 MT
 AT
 TF
 PD
 AX
 SU
 BR
 ST
 RS
 BT
 HA
 SC
 EL
 IDX

ON-VEHICLE SERVICE

Checking Gear Housing Movement

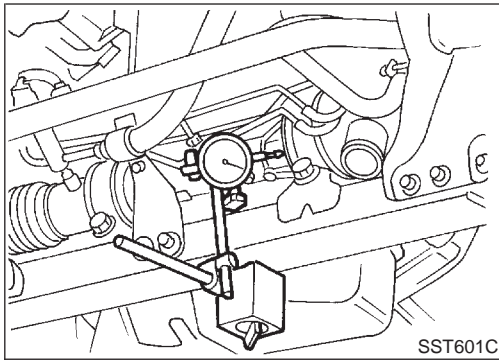

Checking Gear Housing Movement

NAST0008

1. Check the movement of steering gear housing during stationary steering on a dry paved surface.
 - Apply a force of 49 N (5 kg, 11 lb) to steering wheel to check the gear housing movement.
Turn off ignition key while checking.

Movement of gear housing:
 ± 2 mm (± 0.08 in) or less

2. If movement exceeds the limit, replace mount insulator after confirming proper installation of gear housing clamps.

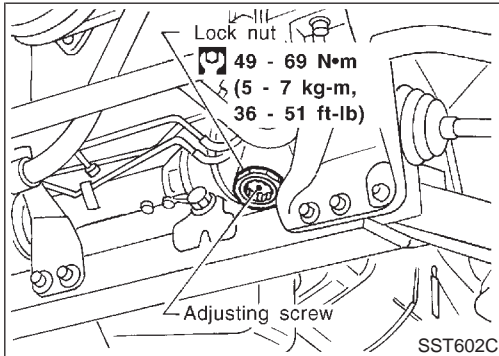

Adjusting Rack Retainer

NAST0009

- Perform this driving test on a flat road.
- a) Check whether vehicle moves in a straight line when steering wheel is released.
- b) Check whether steering wheel returns to neutral position when steering wheel is released from a slightly turned (approx. 20°) position.
- If any abnormality is found, correct it by resetting adjusting screw.

Checking and Adjusting Drive Belts

NAST0010

Refer to MA-14, "Checking Drive Belts".

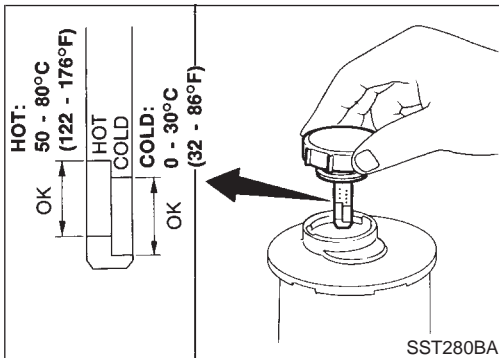

Checking Fluid Level

NAST0011

Check fluid level.

Use the correct range of the dipstick depending on the fluid temperature. Use the "HOT" range at 50 to 80°C (122 to 176°F), or the "COLD" range at 0 to 30°C (32 to 86°F).

CAUTION:

- Do not overfill.
- Recommended fluid is Genuine Nissan PSF II or equivalent. Refer to MA-12, "Fluids and Lubricants".

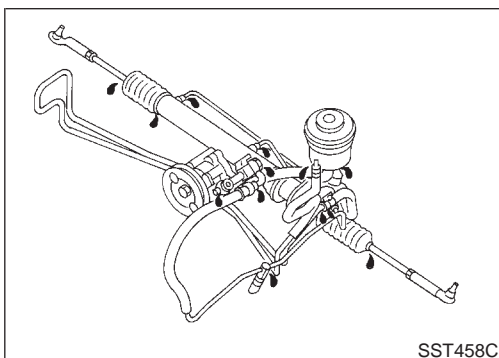

Checking Fluid Leakage

NAST0012

Check the lines for improper attachment and for leaks, cracks, damage, loose connections, chafing and deterioration.

1. Run engine between idle speed and 1,000 rpm.
Make sure temperature of fluid in oil tank rises to 60 to 80°C (140 to 176°F).
2. Turn steering wheel right-to-left several times.
3. Hold steering wheel at each "lock" position for five seconds and carefully check for fluid leakage.

CAUTION:

Do not hold the steering wheel in a locked position for more than 15 seconds.

4. If fluid leakage at connectors is noticed, loosen flare nut and then retighten.

Do not overtighten connector as this can damage O-ring, washer and connector.

5. Check rack boots for accumulation of power steering fluid.

Bleeding Hydraulic System

1. Raise front end of vehicle until wheels are clear of the ground.
2. Add fluid into oil tank to specified level. Then, quickly turn steering wheel fully to right and left and lightly touch steering stoppers. Repeat steering wheel operation until fluid level no longer decreases.
3. Start engine. Repeat step 2 above.
 - Incomplete air bleeding will cause the following to occur. When this happens, bleed air again.
 - a) Air bubbles in reservoir tank
 - b) Clicking noise in oil pump
 - c) Excessive buzzing in oil pump

Fluid noise may occur in the valve or oil pump. This is common when the vehicle is stationary or while turning steering wheel slowly. This does not affect performance or durability of the system.

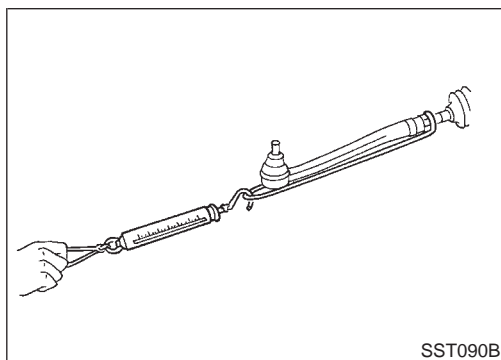
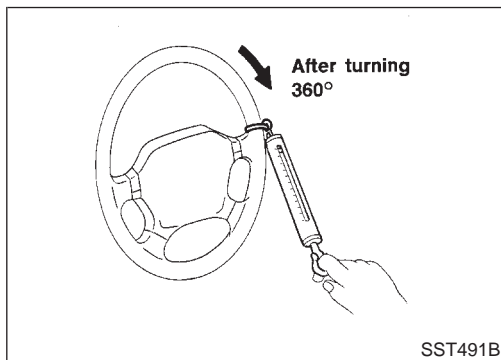

Checking Steering Wheel Turning Force

1. Park vehicle on a level, dry surface and set parking brake.
2. Start engine.
3. Bring power steering fluid up to adequate operating temperature. [Make sure temperature of fluid is approximately 60 to 80°C (140 to 176°F).]

Tires need to be inflated to normal pressure.

4. Check steering wheel turning force when steering wheel has been turned 360° from the neutral position.

**Steering wheel turning force:
39 N (4 kg, 9 lb) or less**

5. If steering wheel turning force is out of specification, check rack sliding force.
 - a. Disconnect steering column lower joint and knuckle arms from the gear.
 - b. Start and run engine at idle to make sure steering fluid has reached normal operating temperature.
 - c. Pull tie-rod slowly to move it from neutral position to ± 11.5 mm (± 0.453 in) at speed of 3.5 mm (0.138 in)/s. Check that rack sliding force is within specification.

**Rack sliding force:
137 - 255 N (14 - 26 kg, 31 - 57 lb)**

GI
MA
EM
LC
EC
FE
CL
MT
AT
TF
PD
AX
SU
BR
ST
RS
BT
HA
SC
EL
IDX

ON-VEHICLE SERVICE

Checking Steering Wheel Turning Force (Cont'd)

6. If rack sliding force is not within specification, overhaul steering gear assembly.
7. If rack sliding force is OK, inspect steering column. Refer to "Inspection", "STEERING WHEEL AND STEERING COLUMN", ST-14.

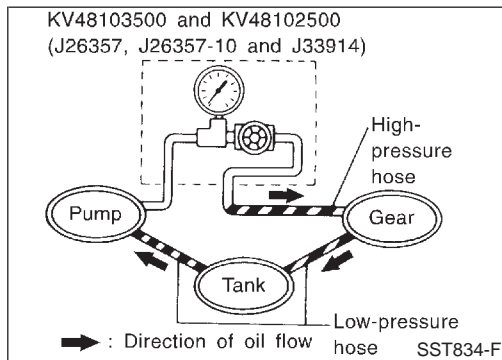

Checking Hydraulic System

NAST0015

Before starting, check belt tension, driving pulley and tire pressure.

1. Set Tool. Open shut-off valve. Then bleed air. Refer to "Bleeding Hydraulic System", ST-9.
2. Run engine, at idle speed or 1,000 rpm.

Make sure fluid temperature in reservoir tank rises to 60 to 80°C (140 to 176°F).

WARNING:

Warm up engine with shut-off valve fully opened. If engine is started with shut-off valve closed, fluid pressure in the power steering pump increase to maximum. This will raise fluid temperature abnormally.

3. Check pressure with steering wheel fully turned to left and right positions with engine idling at 1,000 rpm.

CAUTION:

Do not hold the steering wheel in a locked position for more than 15 seconds.

Power steering pump maximum operating pressure:

8,630 - 9,219 kPa

(88 - 94 kg/cm², 1,251 - 1,337 psi)

- If pressure reaches maximum operating pressure, system is OK.
 - If pressure increases above maximum operating pressure, check power steering pump flow control valve. Refer to ST-28.
4. If power steering pressure is below the maximum operating pressure, slowly close shut-off valve and check pressure again.

CAUTION:

Do not close shut-off valve for more than 15 seconds.

- If pressure increases to maximum operating pressure, gear should be damaged. Refer to "Removal and Installation", ST-18.
 - If pressure remains below maximum operating pressure, pump should be damaged. Refer to "Disassembly", ST-28.
5. After checking hydraulic system, remove Tool and add fluid as necessary. Then completely bleed air out of system. Refer to ST-9.

Components

NAST0016

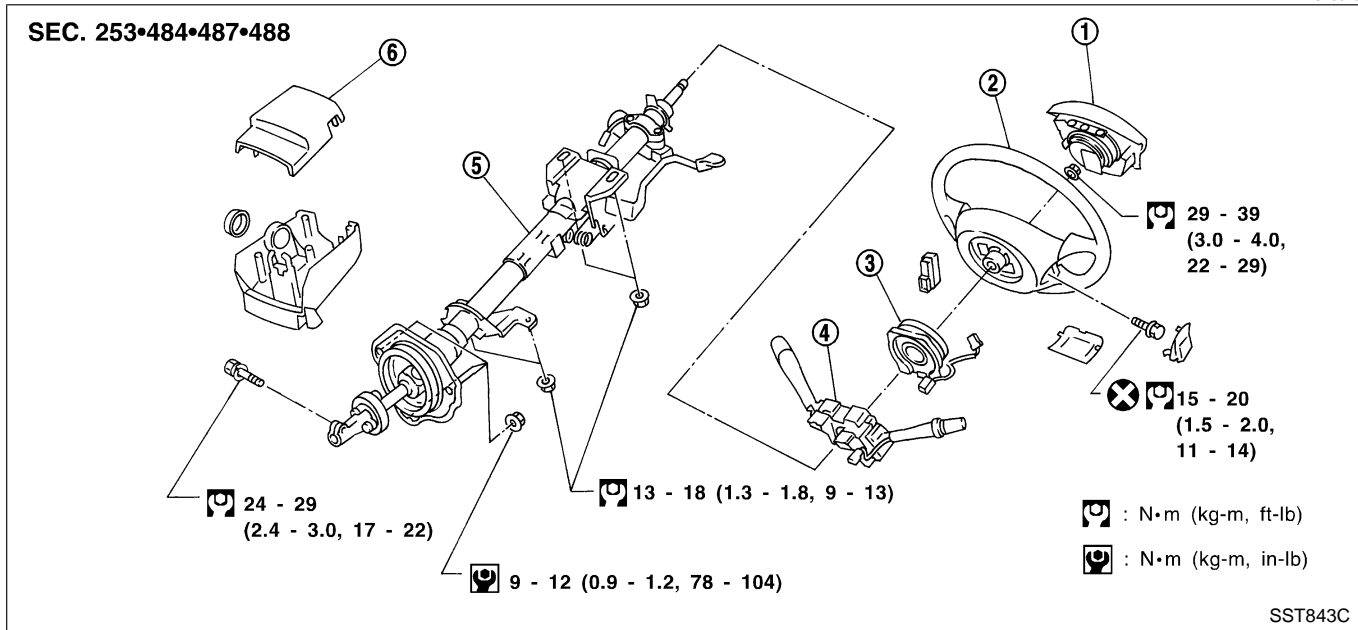

- | | | |
|-------------------|-----------------------|-----------------------------|
| 1. Air bag module | 3. Spiral cable | 5. Steering column assembly |
| 2. Steering wheel | 4. Combination switch | 6. Column cover |

CAUTION:

- The rotation of the spiral cable (SRS "AIR BAG" component part) is limited. If the steering gear must be removed, set the front wheels in the straight-ahead direction. Do not rotate the steering column while the steering gear is removed.
- Remove the steering wheel before removing the steering lower joint to avoid damaging the SRS spiral cable.

Removal and Installation

STEERING WHEEL

NAST0017

NAST0017S01

1. Remove air bag module and spiral cable. Refer to RS-17, "Removal — Air Bag Module and Spiral Cable".

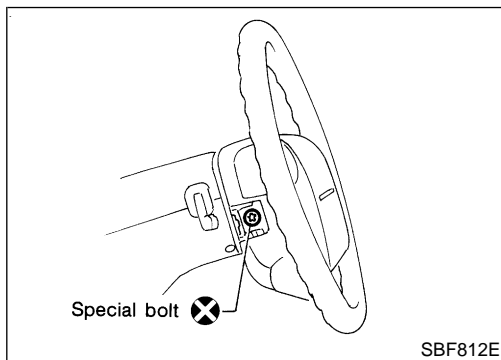

GI
MA
EM
LC
EC
FE
CL
MT
AT
TF
PD
AX
SU
BR
ST
RS
BT
HA
SC
EL
IDX

STEERING WHEEL AND STEERING COLUMN

Removal and Installation (Cont'd)

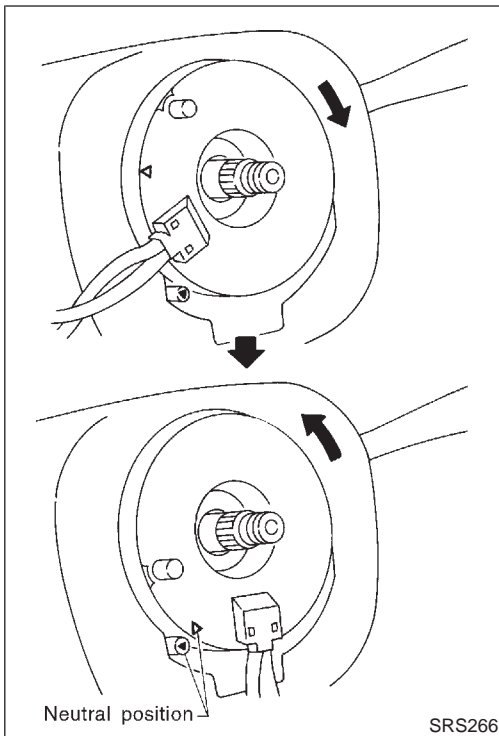

2. Align spiral cable correctly when installing steering wheel.
 - a. Set the front wheels in the straight-ahead position.
 - b. Make sure that the spiral cable is in the neutral position. The neutral position is detected by turning left about 2.5 revolutions from the right end position. Align the two marks (X).

CAUTION:

- The spiral cable may snap due to steering operation if the cable is installed in an improper position.
- Also, with the steering linkage disconnected, the cable may snap by turning the steering wheel beyond the limited number of turns. The spiral cable can be turned to the left about 2.5 turns from the right end position.

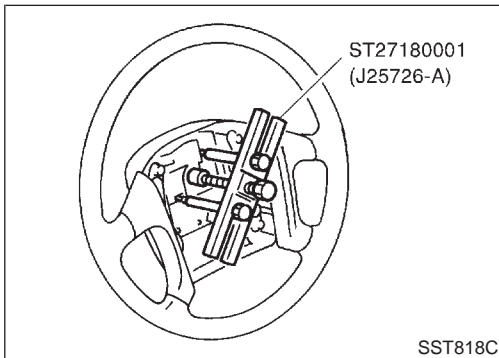

3. Remove steering wheel with Tool.

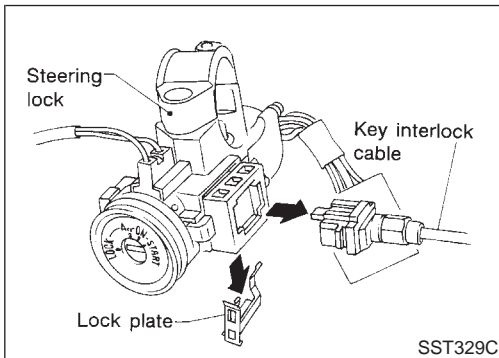

4. Remove key interlock cable.

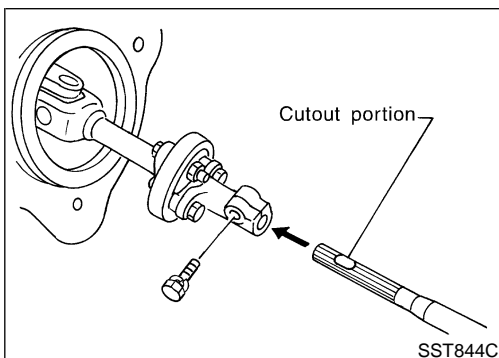

STEERING COLUMN

- When installing steering column, fingertighten all lower bracket and clamp retaining bolts; then tighten them securely. Do not apply undue stress to steering column.
- When attaching coupling joint, be sure tightening bolt faces cutout portion.

NAST0017S02

STEERING WHEEL AND STEERING COLUMN

Disassembly and Assembly

Disassembly and Assembly

MAST0018

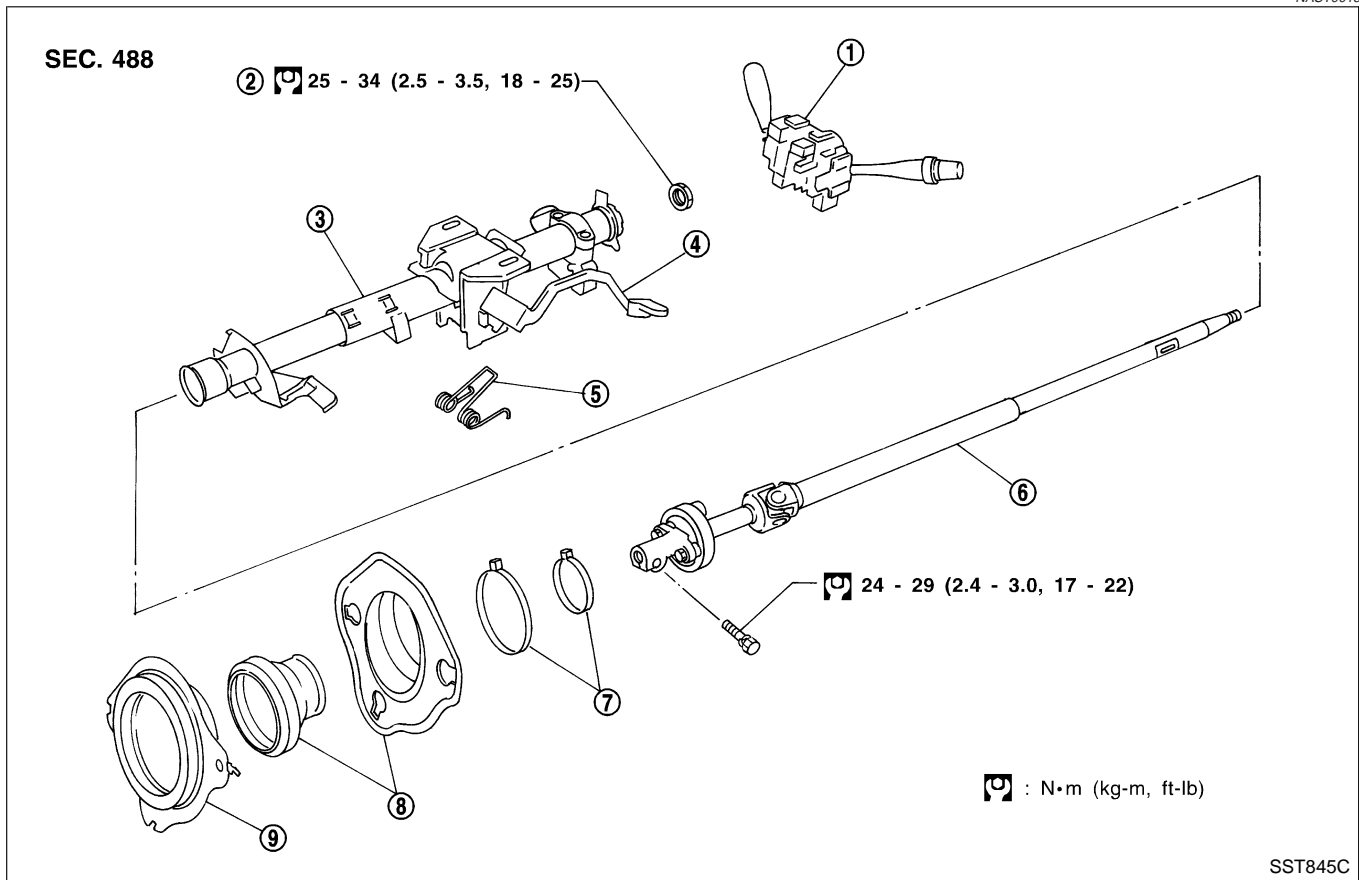

SST845C

- | | | |
|-------------------------|-----------------------------------|---|
| 1. Combination switch | 4. Tilt lever | 7. Band |
| 2. Lock nut | 5. Tilt spring | 8. Jacket tube bracket insulator assembly |
| 3. Jacket tube assembly | 6. Steering column shaft assembly | 9. Hole cover |

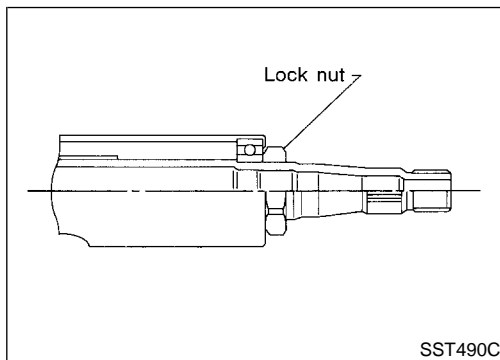

SST490C

- When disassembling and assembling, unlock steering lock with key.
- Install lock nut on steering column shaft and tighten the nut to specification.

☞ : 25 - 34 N·m (2.5 - 3.5 kg-m, 18 - 25 ft-lb)

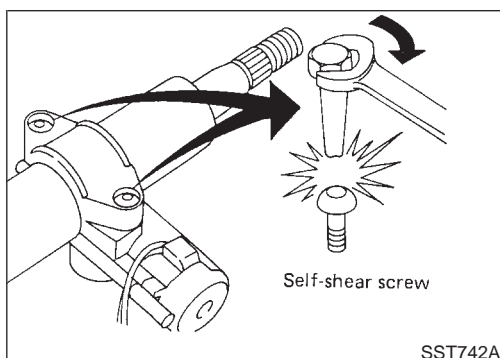

SST742A

- Steering lock
 - a) Break self-shear type screws with a drill or other appropriate tool.
 - b) Install new self-shear type screws and then cut off self-shear type screw heads.

STEERING WHEEL AND STEERING COLUMN

Inspection

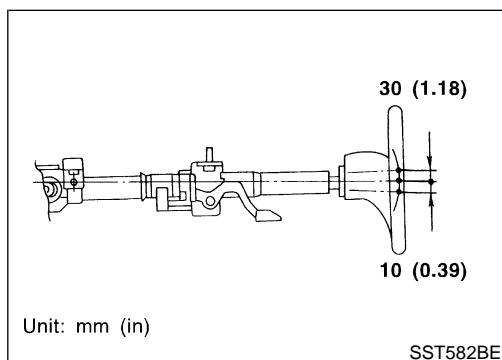
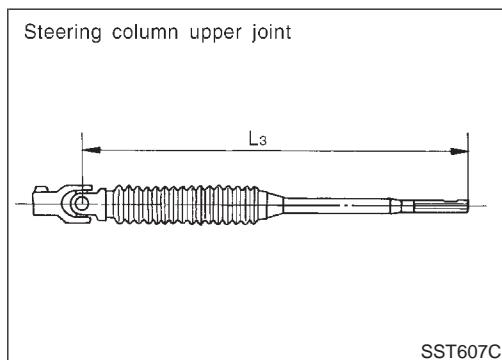
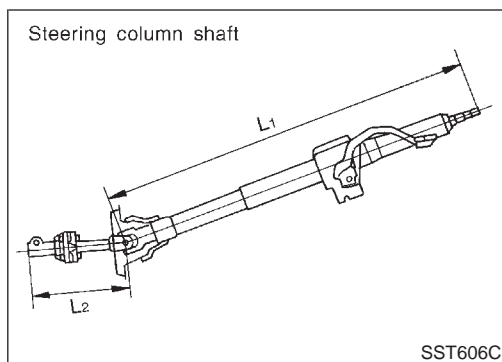

Inspection

NAST0019

- When steering wheel does not turn smoothly, check the steering column as follows and replace damaged parts.
 - a) Check column bearings for damage and unevenness. Lubricate with recommended multi-purpose grease or replace steering column as an assembly, if necessary.
 - b) Check steering column lower shaft for deformation and breakage. Replace if necessary.
- When the vehicle comes into a light collision, check length "L₁", "L₂" and "L₃".

Steering column length "L₁":

716.7 - 718.7 mm (28.22 - 28.30 in)

Steering column lower shaft length "L₂":

178 - 180 mm (7.01 - 7.09 in)

Steering column upper joint length "L₃":

430.7 - 432.7 mm (16.96 - 17.04 in)

If out of the specifications, replace steering column upper joint or steering column as an assembly.

TILT MECHANISM

NAST0019S01

After installing steering column, check tilt mechanism operation.

STEERING TRANSFER GEAR

Removal

Removal

NAST0021

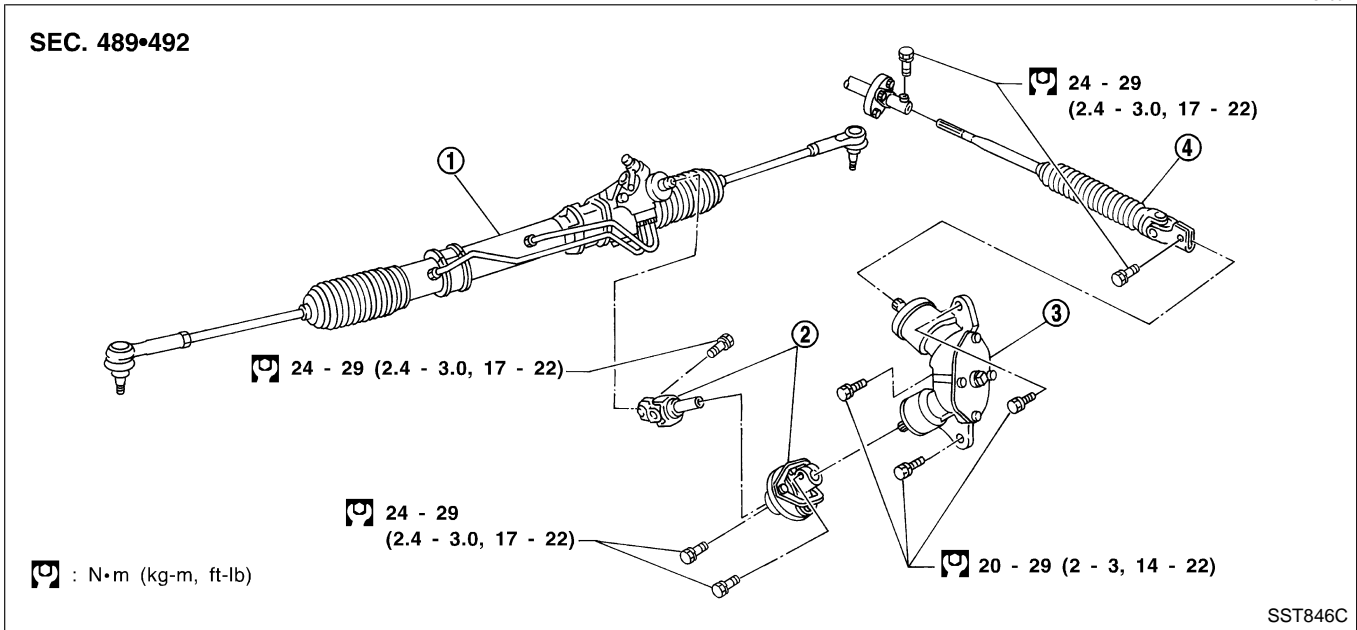

1. Power steering gear assembly
2. Steering column lower joint

3. Transfer gear assembly

4. Steering column upper joint

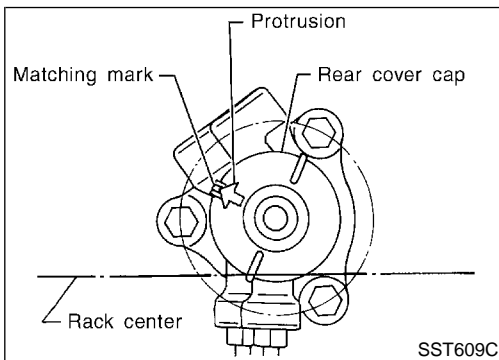

1. Set wheels in the straight-ahead position.
2. Straight-forward position is indicated by a protrusion on the power steering gear rear cover cap and matching mark on the rear housing.

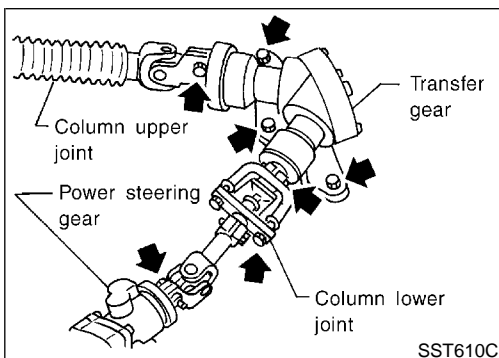

3. Remove steering column upper and lower joint from transfer gear.
4. Remove transfer gear assembly.

GI
MA
EM
LC
EC
FE
CL
MT
AT
TF
PD
AX
SU
BR
ST
RS
BT
HA
SC
EL
IDX

STEERING TRANSFER GEAR

Installation

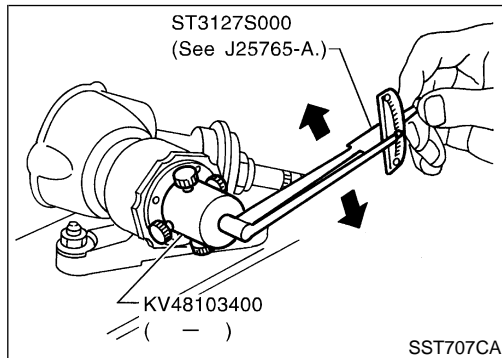
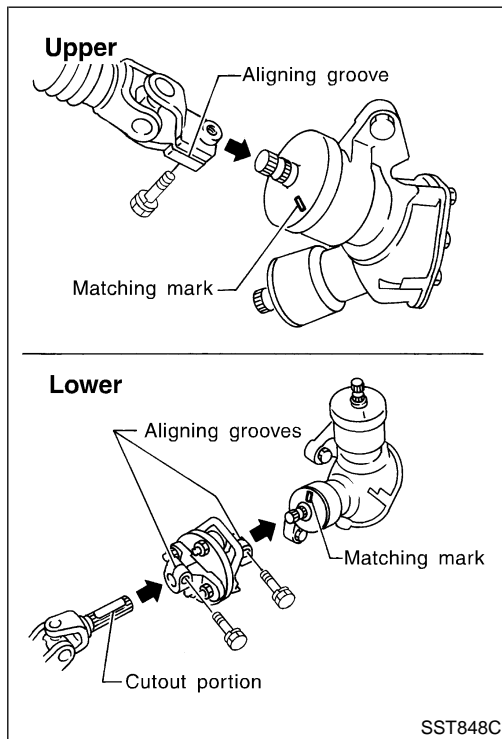
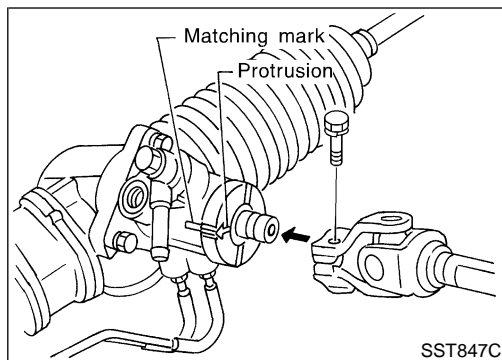

Installation

NAST0022

1. Set wheels in the straight-ahead position.
2. Install transfer gear assembly.
3. Install column lower joint while aligning groove with protrusions on the steering gear rear cover cap.
4. Tighten bolt while aligning groove on steering gear. Before tightening bolt, ensure it is inserted correctly.
5. When attaching steering column upper and lower joint to transfer gear, it must be positioned as shown in figure at left.

Inspection

NAST0024

Do not disassemble steering transfer gear assembly.

- Check that steering transfer gear assembly operates smoothly. Also check for grease leakage, deformation and damage. Replace steering transfer gear assembly if necessary.
- Check rotating torque at input shaft in 360° and in both directions.

Rotating torque:

0.25 - 0.69 N·m (2.5 - 7.0 kg-cm, 2.2 - 6.1 in-lb)

If rotating torque is out of specification, replace steering transfer gear assembly.

POWER STEERING GEAR AND LINKAGE

Components

Components

NAST0026

SEC. 492

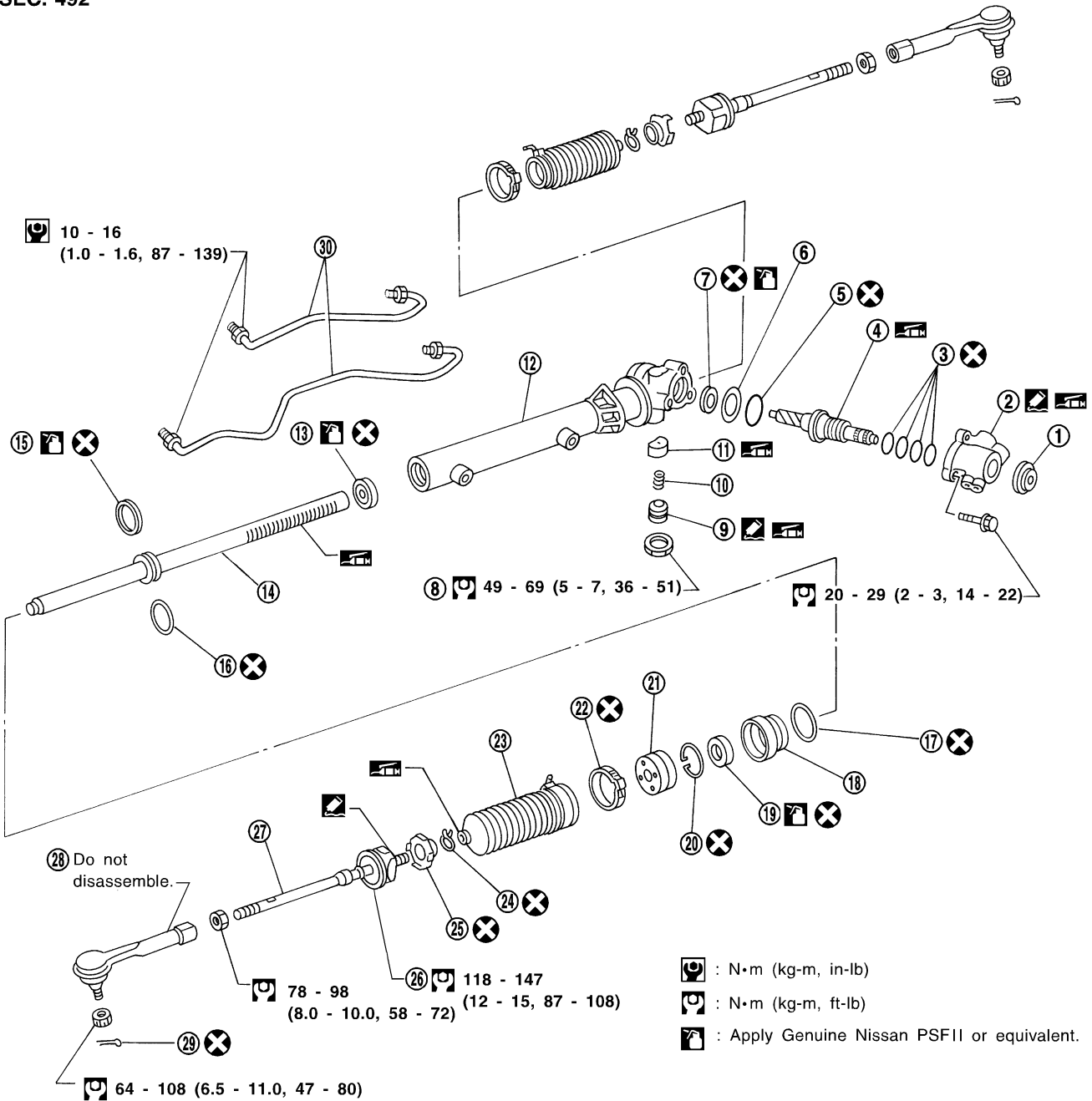

1. Rear cover cap
2. Rear housing assembly
3. Pinion seal ring
4. Pinion assembly
5. O-ring
6. Shim
7. Pinion oil seal
8. Lock nut
9. Adjusting screw
10. Spring

11. Retainer
12. Gear housing assembly
13. Rack oil seal
14. Rack assembly
15. Rack seal ring
16. O-ring
17. O-ring
18. Rack bushing
19. Rack oil seal
20. Snap ring

21. End cover assembly
22. Boot clamp
23. Dust boot
24. Boot clamp
25. Lock plate
26. Tie-rod inner socket
27. Tie-rod
28. Tie-rod outer socket
29. Cotter pin
30. Cylinder tube

SST618CB

GI
MA
EM
LC
EC
FE
CL
MT
AT
TF
PD
AX
SU
BR
ST
RS
BT
HA
SC
EL
IDX

POWER STEERING GEAR AND LINKAGE

Removal and Installation

Removal and Installation

NAST0027

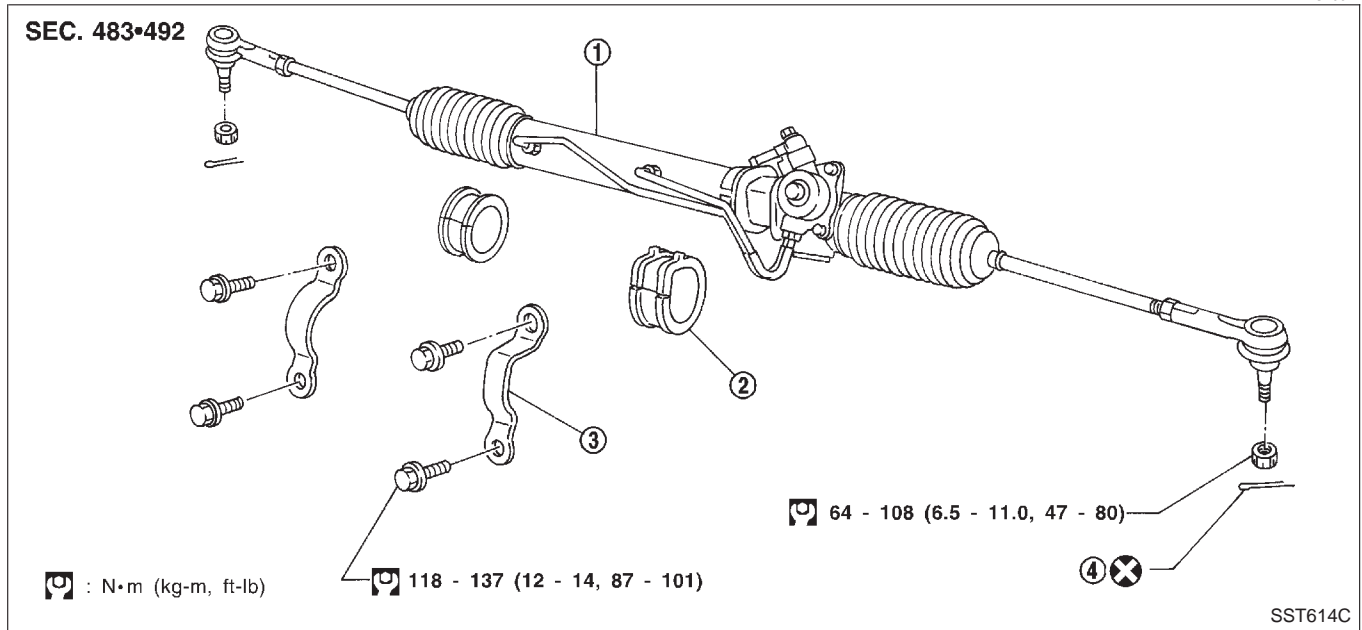

1. Gear and linkage assembly
2. Rack mounting insulator

3. Gear housing mounting bracket

4. Cotter pin

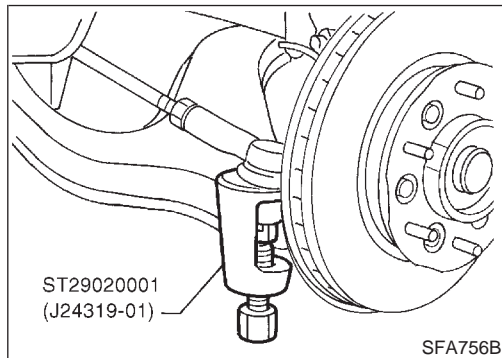

CAUTION:

- The rotation of the spiral cable (SRS “AIR BAG” component part) is limited. If the steering gear must be removed, set the front wheels in the straight-ahead direction. Do not rotate the steering column while the steering gear is removed.
- Remove the steering wheel before removing the steering lower joint to avoid damaging the SRS spiral cable.
- Detach tie-rod outer sockets from knuckle arms with Tool.

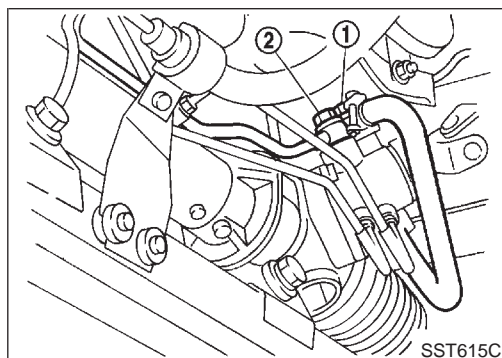

- Install pipe connector.
- Observe specified tightening torque when tightening high-pressure and low-pressure pipe connectors. Excessive tightening will damage threads of connector or O-ring.

Connector tightening torque:

Low-pressure side “1”

30 - 35 N·m (3.1 - 3.6 kg-m, 22 - 26 ft-lb)

High-pressure side “2”

30 - 35 N·m (3.1 - 3.6 kg-m, 22 - 26 ft-lb)

- The O-ring in low-pressure pipe connector is larger than that

POWER STEERING GEAR AND LINKAGE

Removal and Installation (Cont'd)

in high-pressure connector. Take care to install the proper O-ring.

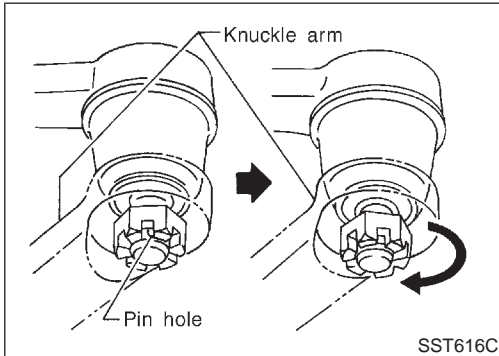

- Initially, tighten nut on tie-rod outer socket and knuckle arm to 64 to 69 N·m (6.5 to 7.0 kg-m, 47 to 51 ft-lb). Then tighten further to align nut groove with first pin hole so that cotter pin can be installed.

CAUTION:
Tightening torque must not exceed 108 N·m (11.0 kg-m, 80 ft-lb).

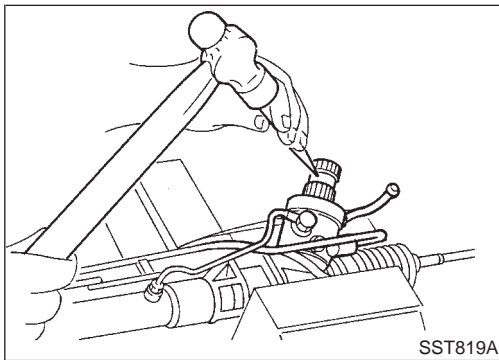

- Before removing steering column lower joint from gear, set gear in neutral (wheels in straight-ahead position). After removing steering column lower joint, put matching mark on pinion shaft and pinion housing to record neutral position.
- To install, set left and right dust boots to equal deflection. Attach steering column lower joint by aligning matching marks of pinion shaft and pinion housing.

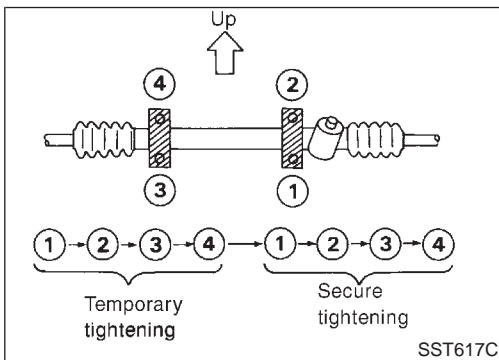

- Tighten gear housing mounting bracket bolts in the order shown.

Secure tightening torque:
118 - 137 N·m (12 - 14 kg-m, 87 - 101 ft-lb)

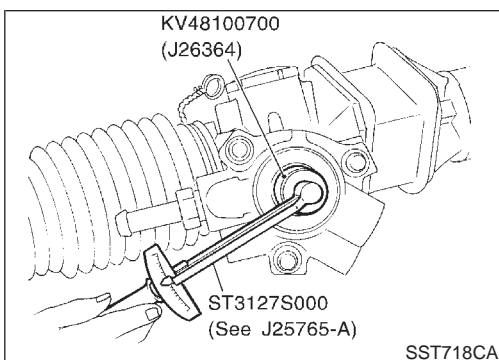

Disassembly

- Prior to disassembling, measure pinion rotating torque. Record the pinion rotating torque as a reference.
 - Before measuring, disconnect cylinder tube and drain fluid.
 - Use soft jaws when holding steering gear housing. Handle gear housing carefully, as it is made of aluminum. Do not grip cylinder in a vise.
- Remove pinion gear.

Be careful not to damage pinion gear when removing pinion seal ring.

GI
MA
EM
LC
EC
FE
CL
MT
AT
TF
PD
AX
SU
BR
ST
RS
BT
HA
SC
EL
IDX

POWER STEERING GEAR AND LINKAGE

Disassembly (Cont'd)

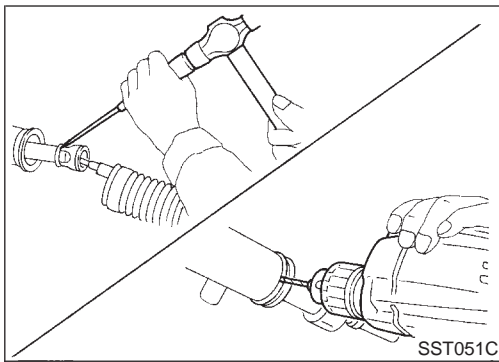

3. Remove tie-rod outer sockets and boots.
4. Loosen tie-rod inner socket by prying up staked portion, and remove socket.
5. Remove retainer.
6. Remove pinion assembly.
7. Use a 2 to 2.5 mm (0.079 to 0.098 in) diameter drill to completely remove staked portion of gear housing end.

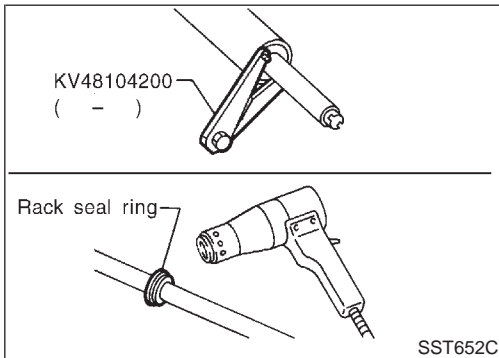

8. Remove gear housing end cover assembly with a suitable tool.
9. Draw out rack assembly.
10. Remove rack seal ring.
 - Using a heat gun, heat rack seal to approximately 40°C (104°F).
 - Remove rack seal ring.

Be careful not to damage rack.

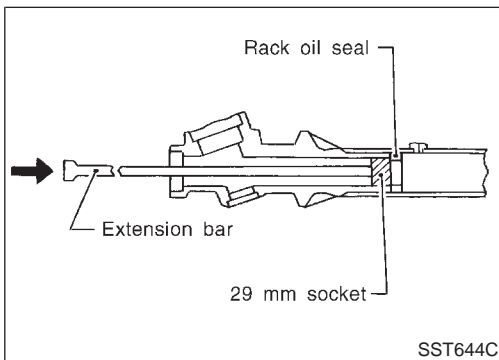

11. Remove rack bushing and rack oil seal using tape wrapped socket and extension bar.

Do not scratch inner surfaces of pinion housing.

Inspection

Thoroughly clean all parts in cleaning solvent or Genuine Nissan PSF II or equivalent. Blow dry with compressed air, if available.

BOOT

- Check condition of boot. If cracked excessively, replace it.
- Check boots for accumulation of power steering fluid.

RACK

Thoroughly examine rack gear. If damaged, cracked and worn, replace it.

PINION ASSEMBLY

- Thoroughly examine pinion gear. If pinion gear is damaged, cracked and worn, replace it.
- Check that all bearings roll freely. Ensure that balls, rollers and races are not cracked, pitted and worn.

GEAR HOUSING CYLINDER

Check gear housing cylinder bore for scratches and other damage. Replace if necessary.

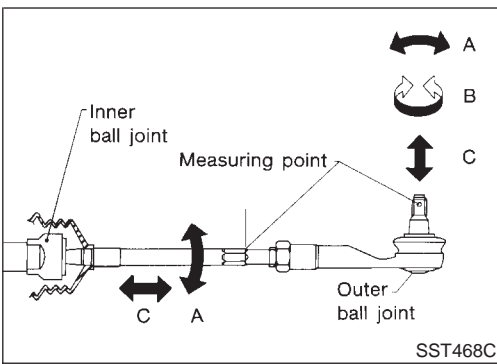

TIE-ROD OUTER AND INNER SOCKETS

MAST0029S05

- Check ball joints for swinging force.
Tie-rod outer and inner ball joints swinging force "A":
Refer to SDS, ST-33.
- Check ball joint for rotating torque.
Tie-rod outer ball joint rotating torque "B":
Refer to SDS, ST-33.
- Check ball joints for axial end play.
Tie-rod outer and inner ball joints axial end play "C":
Refer to SDS, ST-33.
- Check condition of dust cover. If cracked excessively, replace outer tie-rod.

GI
MA
EM
LC
EC
FE
CL
MT
AT
TF
PD
AX
SU
BR
ST
RS
BT
HA
SC
EL
IDX

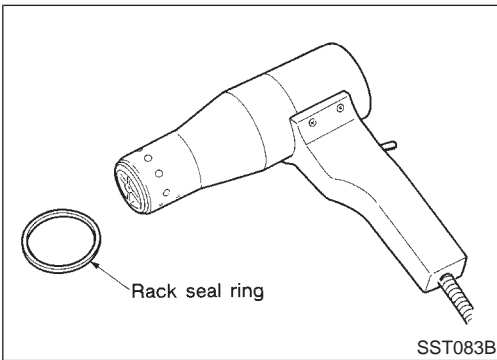

Assembly

MAST0030

1. Using a heat gun, heat new teflon rack seal ring to approximately 40°C (104°F). Then place it onto rack.

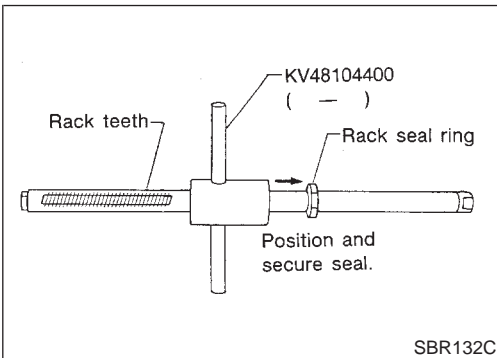

2. Using Tool, compress rack seal ring securely on rack.
Always insert Tool from the rack gear side.

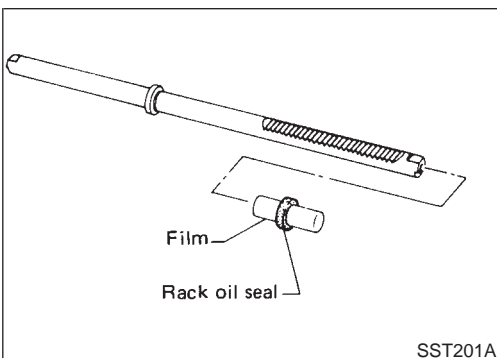

3. Insert new rack oil seal.
 - Place plastic film into rack oil seal to prevent damage by rack teeth.
 - Do not forget to remove plastic film after rack oil seal is positioned properly.
 - Make sure lips of rack oil seal face each other.

POWER STEERING GEAR AND LINKAGE

Assembly (Cont'd)

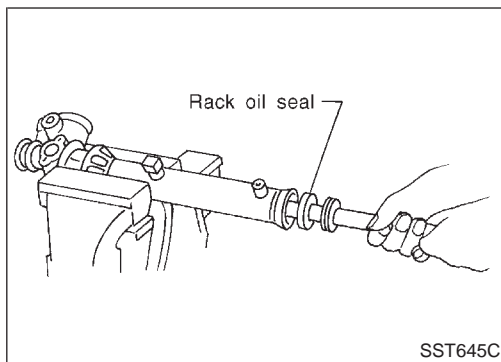

4. Install rack oil seal and rack bushing with rack assembly.

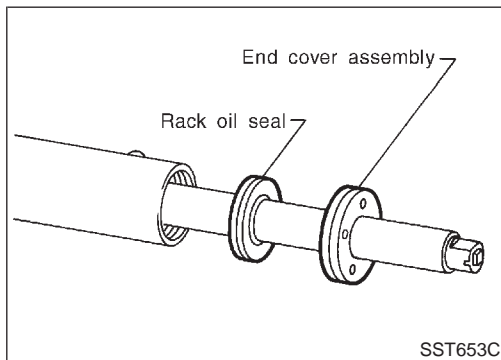

5. Insert rack oil seal and end cover assembly to rack. Then tighten end cover assembly.

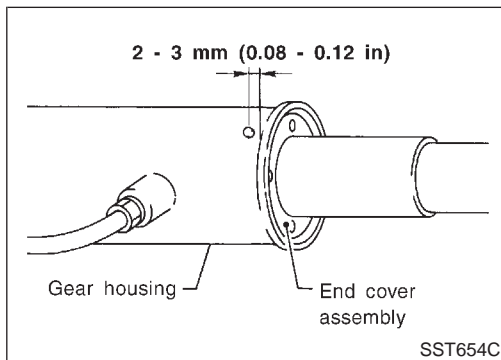

6. Fasten cylinder end cover assembly to gear housing by staking.

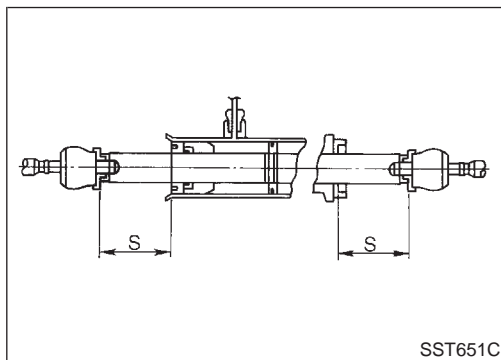

7. Set rack gear in the neutral position.

Rack stroke "S":

Refer to SDS, ST-33.

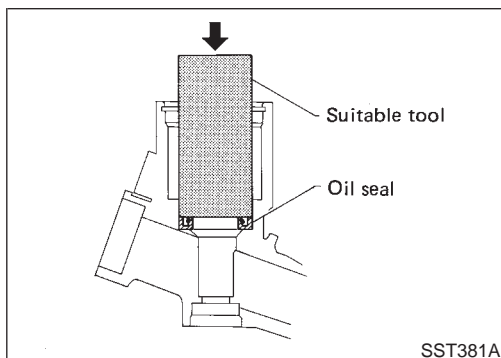

8. Coat seal lip of new pinion oil seal with multi-purpose grease. Install it into pinion housing of gear with a suitable tool.

Make sure lip of oil seal faces up when installed.

POWER STEERING GEAR AND LINKAGE

Assembly (Cont'd)

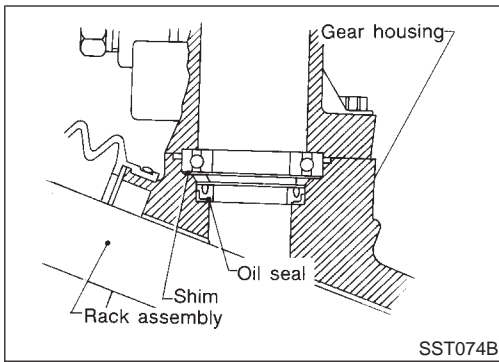

9. Install pinion bearing adjusting shim(s).
 - Whenever pinion assembly, gear housing and rear housing are disassembled, replace shim(s) with new ones. Always use the same number of shim(s) when replacing.

GI
MA
EM
LC

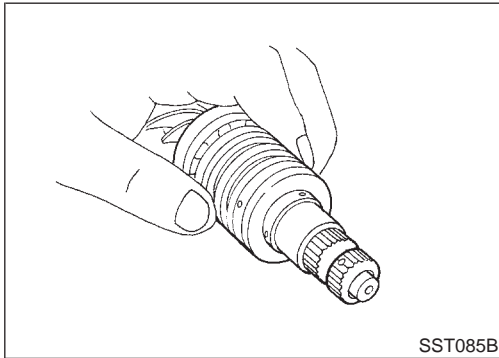

10. Install new pinion seal ring (made of Teflon) on pinion gear assembly.
 - Using a heat gun, heat pinion seal ring to approximately 40°C (104°F) before installing it onto pinion gear assembly.
 - Make sure pinion seal ring is properly settled in valve groove.

EC
FE
CL

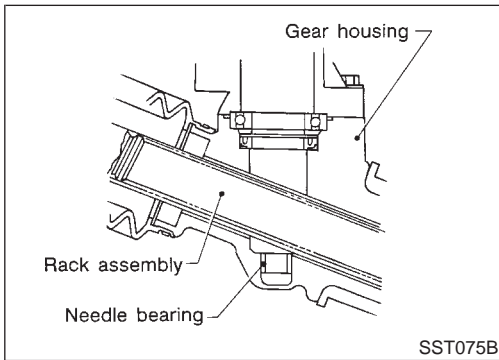

11. Apply a coat of multi-purpose grease to needle bearing roller and oil seal lip.

MT
AT

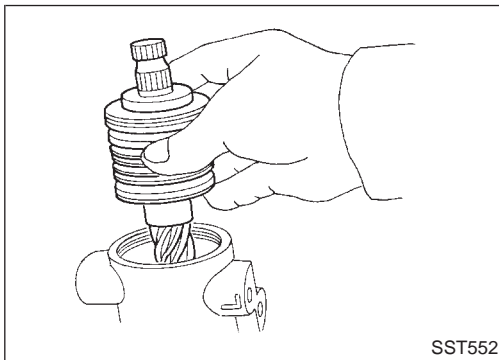

12. Install pinion assembly to rear housing.
Be careful not to damage pinion oil seal.

TF
PD
AX
SU

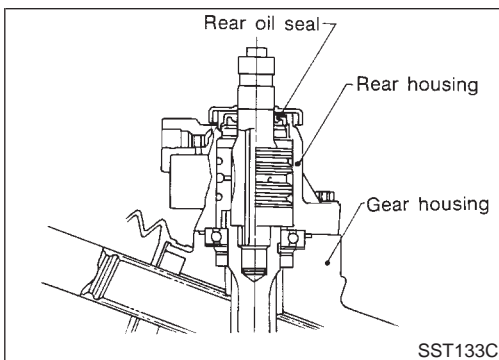

13. Apply a coat of multi-purpose grease to new rear oil seal lip before installing rear housing.

BR
ST
RS
BT
HA
SC
EL
IDX

POWER STEERING GEAR AND LINKAGE

Assembly (Cont'd)

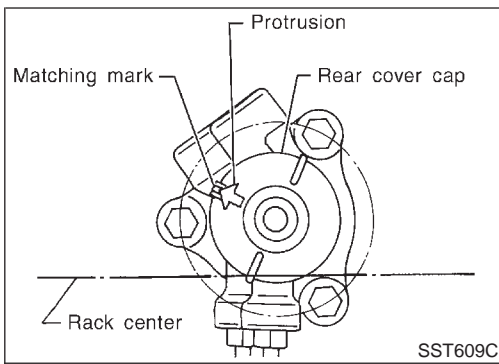

14. Ensure that the rack is centered. Install rear cover cap so that its protrusion is positioned as shown in figure.

Be careful not to damage worm ring and oil seal.

15. Install retainer, spring and adjusting screw temporarily.

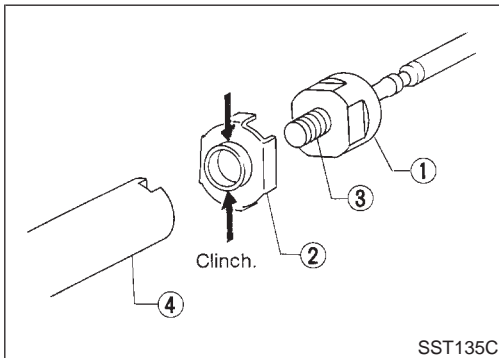

16. Install new lock plate.

- Attach lock plate 2 to side rod inner socket 1.
- Apply locking sealant to inner socket threads 3. Screw inner socket into rack 4 and tighten to specified torque.
- Clinch two places of lock plate at rack's groove.

CAUTION:

To prevent scratching the boot, remove burrs from lock plate.

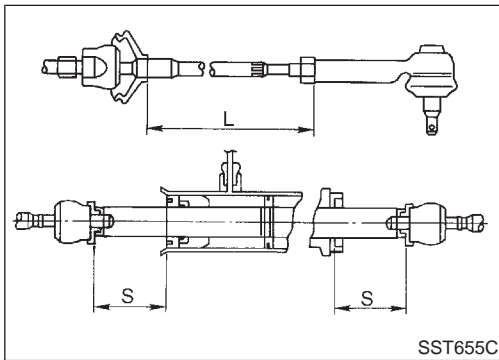

17. Tighten outer socket lock nut.

Tie-rod length "L":

Refer to SDS, ST-33.

18. Measure rack stroke.

Rack stroke "S":

Refer to SDS, ST-33.

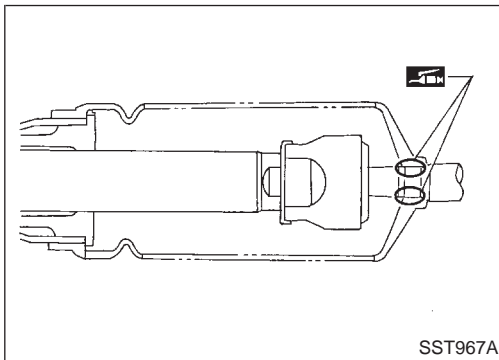

19. Before installing boot, coat the contact surfaces between boot and tie-rod with grease.

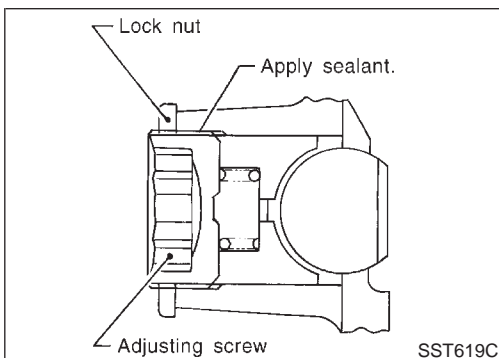

Adjustment

NAST0031

Adjust pinion rotating torque as follows:

1. Set rack to the neutral position without fluid in the gear.
2. Coat the adjusting screw with locking sealant and screw it in.
3. Lightly tighten lock nut.
4. Tighten adjusting screw to a torque of 4.9 to 5.9 N·m (50 to 60 kg-cm, 43 to 52 in-lb).
5. Loosen adjusting screw, then retighten it to 0.2 N·m (2 kg-cm, 1.7 in-lb).

POWER STEERING GEAR AND LINKAGE

Adjustment (Cont'd)

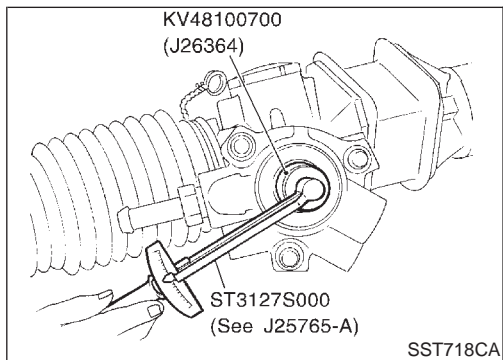
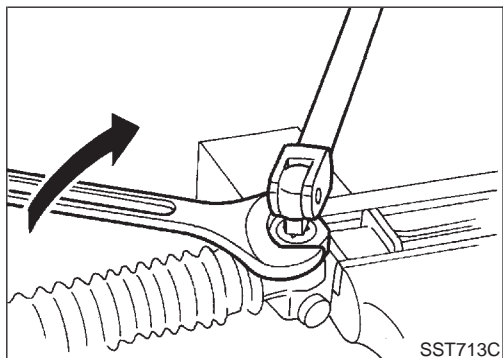
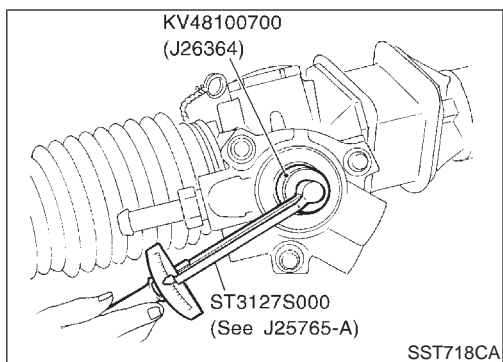

6. Move rack over its entire stroke several times.
7. Measure pinion rotating torque within the range of 180° from neutral position.
Stop the gear at the point of maximum torque.
8. Loosen adjusting screw, then retighten it to 4.9 to 5.9 N·m (50 to 60 kg·cm, 43 to 52 in·lb).
9. Loosen adjusting screw by 10° to 20°.

10. Prevent adjusting screw from turning, and tighten lock nut to specified torque.

11. Measure pinion rotating torque.

Lock to lock:

Average rotating torque

0.78 - 1.47 N·m (8.0 - 15.0 kg·cm, 6.9 - 13.0 in·lb)

Within ±100° from the neutral position:

Maximum torque variation

0.4 N·m (4 kg·cm, 3.5 in·lb)

Outside the above range:

Maximum force variation

0.6 N·m (6 kg·cm, 5.2 in·lb)

- If pinion rotating torque is not within specifications, readjust it starting from step 4. If pinion rotating torque is still out of specifications after readjustment, replace steering gear assembly.

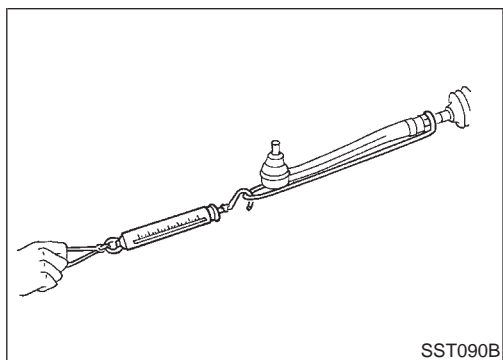

12. Check rack sliding force on vehicle as follows:
 - a. Install steering gear onto vehicle, but do not connect tie-rod to knuckle arm.
 - b. Connect all piping and fill with steering fluid.
 - c. Start engine and bleed air completely.
 - d. Disconnect steering column lower joint from the gear.
 - e. Keep engine at idle and make sure steering fluid has reached normal operating temperature.
 - f. Pull tie-rod slowly to move it from neutral position to ±11.5 mm (±0.453 in) at speed of 3.5 mm (0.138 in)/s. Check that rack sliding force is within specification.

GI
MA
EM
LC
EC
FE
CL
MT
AT
TF
PD
AX
SU
BR
ST
RS
BT
HA
SC
EL
IDX

POWER STEERING GEAR AND LINKAGE

Adjustment (Cont'd)

Rack sliding force:

167 - 254 N (17.0 - 25.9 kg, 37 - 57 lb)

- If rack sliding force is not within specification, readjust by repeating adjustment procedure from the beginning.
- If rack sliding force is still out of specification after readjustment, gear assembly needs to be replaced.

Components

MAST0032

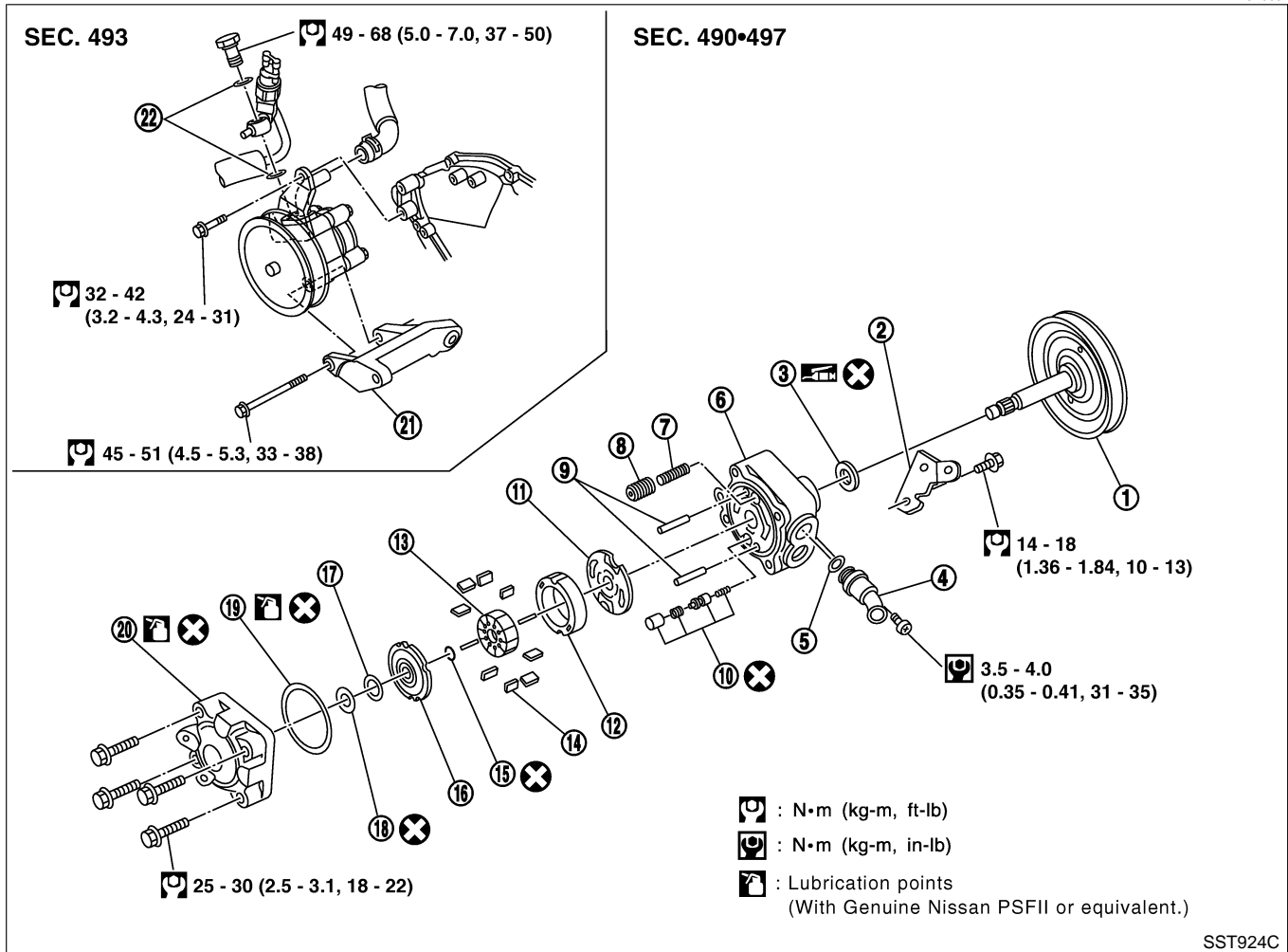

- | | | |
|------------------------------|-----------------------------------|---------------------------------|
| 1. Pulley | 9. Dowel pin | 16. Side plate (Rear) |
| 2. Front bracket | 10. Flow control B valve assembly | 17. Side plate inner seal |
| 3. Oil seal | 11. Side plate (Front) | 18. Side plate outer seal |
| 4. Suction pipe | 12. Cam ring | 19. O-ring |
| 5. O-ring | 13. Rotor | 20. Rear cover |
| 6. Casing | 14. Vane | 21. Power steering pump bracket |
| 7. Flow control valve spring | 15. Snap ring | 22. Copper washer |
| 8. Flow control A valve | | |

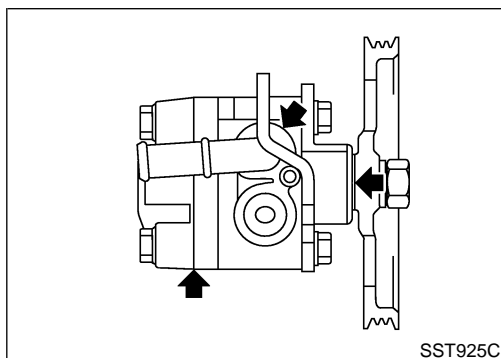

Pre-disassembly Inspection

MAST0033

Disassemble the power steering oil pump only if the following items are found.

- Oil leak from any point shown in the figure.
- Deformed or damaged pulley.
- Poor performance.

GI
MA
EM
LC
EC
FE
CL
MT
AT
TF
PD
AX
SU
BR
ST
RS
BT
HA
SC
EL
IDX

POWER STEERING OIL PUMP

Disassembly

Disassembly

NAST0034

CAUTION:

- Parts which can be disassembled are strictly limited. Never disassemble parts other than those specified.
- Disassemble in as clean a place as possible.
- Clean your hands before disassembly.
- Do not use rags; use nylon cloths or paper towels.
- Follow the procedures and cautions in the Service Manual.
- When disassembling and reassembling, do not let foreign matter enter or contact the parts.

1. Fix power steering pump to vise.

CAUTION:

When fixing the pump to vise, use an aluminum plate or such to avoid damaging the fitting plane of the steering pump.

2. Remove the front bracket mounting bolt, and remove the front bracket from the casing.
3. Remove the cover body mounting bolt, and remove the rear cover from the casing.
4. Remove the O-ring from the casing.
5. Remove side plate (rear side) from cam ring, then remove side plate inner/outer seals from side plate (rear side).
6. Remove rotor snap ring using snap ring pliers, and remove pulley from casing.

CAUTION:

Do not damage pulley shaft when removing rotor snap ring.

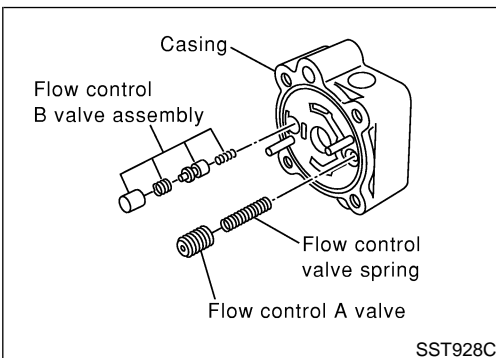
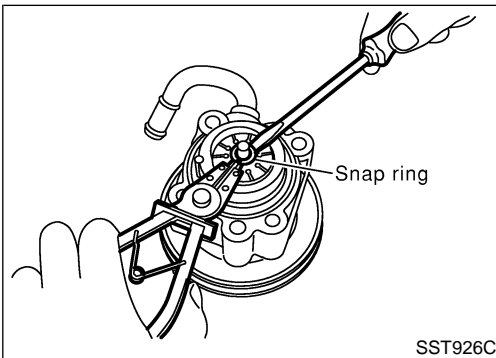

7. Remove the followings from casing.

- Cam ring
- Rotor
- Vane
- Side plate (front side)
- Flow control A valve
- Flow control valve spring
- Flow control B valve assembly

CAUTION:

Be careful not to drop flow control valve.

8. Remove inlet connector mounting bolt, and remove inlet connector from casing.
9. Remove inlet connector seal from inlet connector.
10. Remove drive shaft seal from casing with a screwdriver.

CAUTION:

Do not damage casing surface with the screwdriver.

Inspection

MAST0035

- If pulley is cracked or deformed, replace it.
- If an oil leak is found around pulley shaft oil seal, replace the seal.
- Check the casing and the inside of the rear body for damage. If damages are found in the rear body, replace the entire rear body. If the casing is damaged, replace the entire power steering pump as an assembly.
- Check the cam ring for damage. If damage is found, replace the cam ring, rotor and vane as a set.
- Check the side plates (front and rear) for damage. If damage is found, replace the side plates as a set (front and rear).

GI
MA
EM
LC
EC
FE
CL
MT
AT
TF
PD
AX
SU
BR
ST
RS
BT
HA
SC
EL
IDX

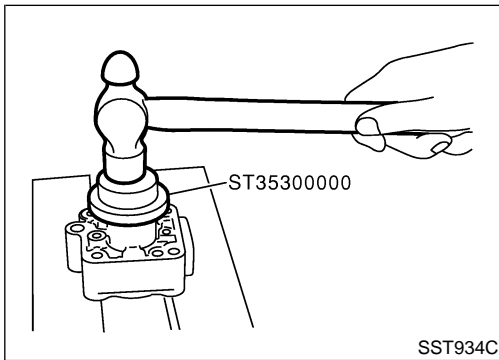

Assembly

MAST0036

1. Apply grease to the lip of the drive shaft seal, and attach the casing.

CAUTION:

The drive shaft seal cannot be reused. Always replace after every disassembly.

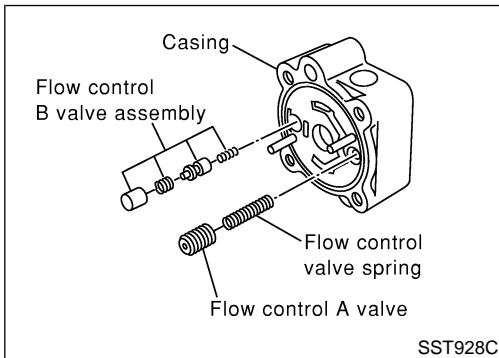

2. When removing the dowel pin, if it is difficult to insert with your hands, insert into the casing by tapping lightly with a hammer or similar tool.
3. Attach the flow control A valve, flow control valve spring, and the flow control B valve assembly to the locations indicated in the drawing left.

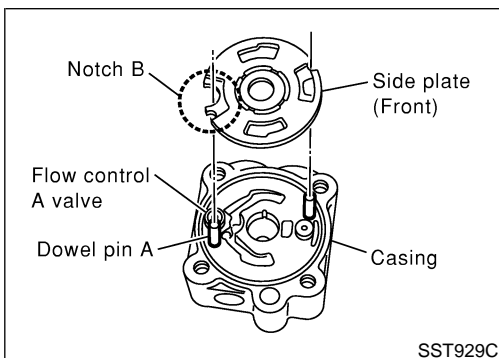

4. Match the dowel pin A on the flow control A valve side with the notch B of the side plate (front), and attach the side plate (front) to the casing.

POWER STEERING OIL PUMP

Assembly (Cont'd)

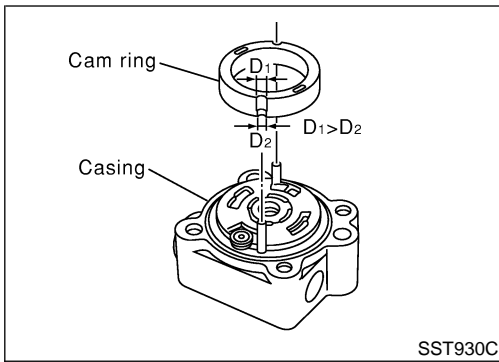

5. Face the cam ring side with fewer pores towards the casing, and attach the cam ring on top of the side plate (front).
6. Attach the pulley to the casing.

CAUTION:
Attach with care so as not to damage the drive shaft seal.

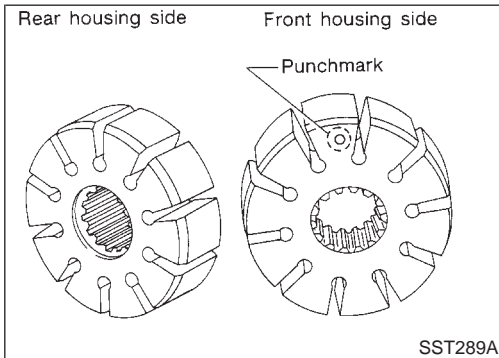

7. Face the side of the rotor with the punch mark towards the casing, and attach the rotor to the pulley shaft.

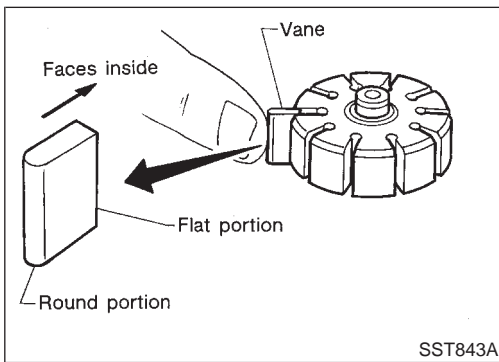

8. Attach the vane to the rotor so that the vane's arc touches the cam ring.

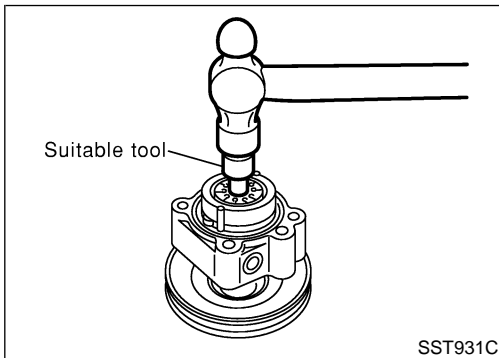

9. Use a hammer or suitable tool to insert the rotor snap ring into the pulley shaft channel.

CAUTION:

- The rotor snap ring cannot be reused. Always replace after every disassembly.
- Insert with care so as not to damage the rotor or the pulley shaft.
- If the rotor is damaged, replace the power steering as an assembly.

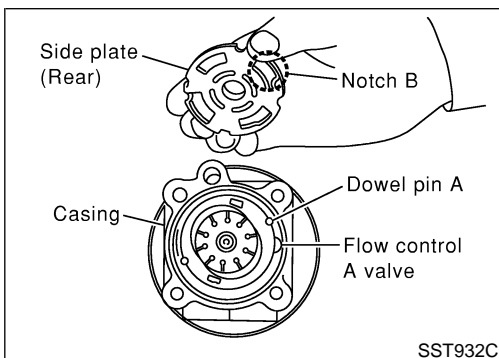

10. Match the dowel pin A on the flow control A valve side with the notch B of the side plate (rear), and attach the side plate (rear) to the cam ring.

11. Apply Genuine Nissan PSF II or equivalent to O-ring and attach to the casing.

CAUTION:
The O-ring cannot be reused. Always replace after every disassembly.

POWER STEERING OIL PUMP

Assembly (Cont'd)

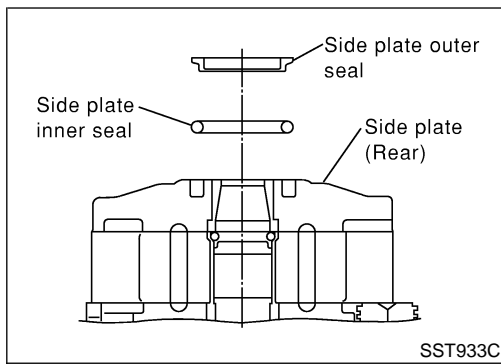

12. Attach a side plate inner seal and side plate outer seal with Genuine Nissan PSF II or equivalent applied, to the side plate (rear).

CAUTION:

The side plate inner seal and outer seal cannot be reused. Always replace after every disassembly.

13. Set the power steering pump on the vice.

CAUTION:

When securing to the vice, use an aluminum plate or other material to protect the installation surface of the power steering pump from damage.

14. Attach the rear body to the casing, and secure the bolts (4 bolts) in a diagonal order to the specified torque.

15. Attach the front bracket to the casing, and secure the bolts (2 bolts) to the specified torque.

16. Attach the inlet collector seal to the grooves of the inlet collector, and attach the inlet collector to the casing with attachment bolts.

CAUTION:

The inlet collector seal cannot be reused. Always replace after every disassembly.

GI

MA

EM

LC

EC

FE

CL

MT

AT

TF

PD

AX

SU

BR

ST

RS

BT

HA

SC

EL

IDX

SERVICE DATA AND SPECIFICATIONS (SDS)

General Specifications

General Specifications

MAST0037

Applied model	All
Steering model	Power steering
Steering gear type	PR32K
Steering overall gear ratio	17.2
Turns of steering wheel (Lock to lock)	3.09
Steering column type	Collapsible, tilt

Steering Wheel

MAST0038
Unit: mm (in)

Steering wheel axial play	0 (0)
Steering wheel play	35 (1.38) or less
Movement of gear housing	± 2 (± 0.08) or less

Steering Column

MAST0039
Unit: mm (in)

Steering column length "L ₁ "	716.7 - 718.7 (28.22 - 28.30)
Steering column lower shaft length "L ₂ "	178 - 180 (7.01 - 7.09)
Steering column upper joint length "L ₃ "	430.7 - 432.7 (16.96 - 17.04)

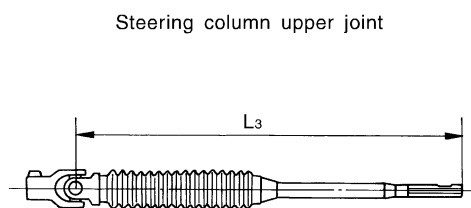
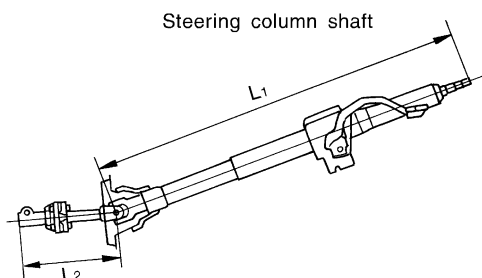

SST739C

Steering Transfer Gear

MAST0041

Rotating torque	0.25 - 0.69 N·m (2.5 - 7.0 kg·cm, 2.2 - 6.1 in·lb)
-----------------	--

SERVICE DATA AND SPECIFICATIONS (SDS)

Steering Gear and Linkage

Steering Gear and Linkage

NAST0040

Applied model	All	
Steering gear type	PR32K	
Tie-rod outer ball joint	Swinging force at cotter pin hole: "A"	4.9 - 47.1 N (0.5 - 4.8 kg, 1.1 - 10.6 lb)
	Rotating torque: "B"	0.3 - 2.9 N·m (3 - 30 kg·cm, 2.6 - 26.0 in·lb)
	Axial end play: "C"	0.1 mm (0.004 in) or less
Tie-rod inner ball joint	Swinging force*: "A"	3.9 - 32.4 N (0.4 - 3.3 kg, 0.9 - 7.3 lb)
	Axial end play: "C"	0.3 mm (0.012 in) or less
Tie-rod standard length "L"	200 mm (7.87 in)	
Rack stroke "S"	72.0 mm (2.835 in)	
Pinion gear preload without gear fluid	Lock to lock Average rotating torque	0.78 - 1.47 N·m (8.0 - 15.0 kg·cm, 6.9 - 13.0 in·lb)
	Within $\pm 100^\circ$ from the neutral position Maximum torque variation	0.4 N·m (4 kg·cm, 3.5 in·lb)
	Outside the above range Maximum torque variation	0.6 N·m (6 kg·cm, 5.2 in·lb)

*: Measuring point [l : 240 mm (9.45 in)]

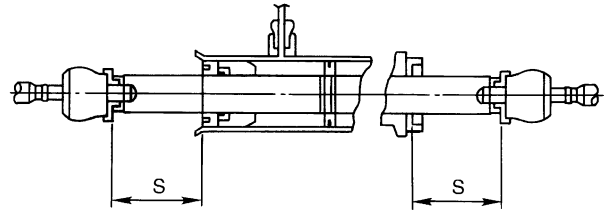
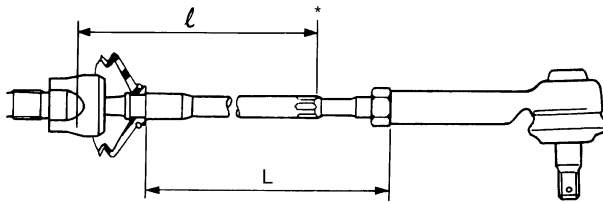

SST740C

Power Steering

NAST0042

Steering gear type	PR32K	
Rack sliding force Under normal operating oil pressure	137 - 255 N (14 - 26 kg, 31 - 57 lb)	
Retainer adjustment (Adjustment screw)	Initial tightening torque	4.9 - 5.9 N·m (50 - 60 kg·cm, 43 - 52 in·lb)
	Retightening torque after loosening	0.2 N·m (2 kg·cm, 1.7 in·lb)
	Tightening torque after gear has settled	4.9 - 5.9 N·m (50 - 60 kg·cm, 43 - 52 in·lb)
	Returning angle	10° - 20°
Steering wheel turning force (Measured at one full turn from the neutral position)	39 N (4 kg, 9 lb) or less	
Fluid capacity (Approximate)	0.9ℓ (1 US qt, 3/4 Imp qt)	
Oil pump maximum pressure	8,630 - 9,219 kPa (88 - 94 kg/cm ² , 1,251 - 1,337 psi)	

NOTES