

ENGINE LUBRICATION & COOLING SYSTEMS

GI

MA

EM

LC

EC

FE

CL

MT

AT

TF

PD

AX

SU

BR

ST

RS

BT

HA

SC

EL

IDX

SECTION LC

CONTENTS

| | | |
|---|--|--|
| ENGINE LUBRICATION SYSTEM2 | CHECKING RADIATOR CAP12 | |
| Precautions2 | CHECKING COOLING SYSTEM FOR LEAKS13 | |
| LIQUID GASKET APPLICATION PROCEDURE.....2 | Water Pump13 | |
| Preparation2 | REMOVAL AND INSTALLATION.....13 | |
| SPECIAL SERVICE TOOLS2 | REMOVAL.....13 | |
| COMMERCIAL SERVICE TOOL3 | INSPECTION.....15 | |
| Lubrication Circuit.....3 | INSTALLATION.....16 | |
| Oil Pressure Check.....5 | Thermostat.....18 | |
| Oil Pump6 | REMOVAL AND INSTALLATION.....18 | |
| REMOVAL AND INSTALLATION.....6 | INSPECTION.....18 | |
| DISASSEMBLY AND ASSEMBLY.....6 | Water Control Valve.....19 | |
| OIL PUMP INSPECTION7 | REMOVAL AND INSTALLATION.....19 | |
| REGULATOR VALVE INSPECTION7 | INSPECTION.....20 | |
| OIL FILTER8 | Radiator21 | |
| Oil Cooler.....8 | REMOVAL AND INSTALLATION.....21 | |
| REMOVAL AND INSTALLATION.....8 | Cooling Fan (Crankshaft driven)22 | |
| INSPECTION.....9 | REMOVAL AND INSTALLATION.....22 | |
| Service Data and Specifications (SDS).....9 | INSPECTION.....22 | |
| OIL PRESSURE9 | Refilling Engine Coolant22 | |
| REGULATOR VALVE9 | Radiator (Aluminum type).....23 | |
| OIL PUMP9 | PREPARATION23 | |
| ENGINE COOLING SYSTEM10 | DISASSEMBLY.....23 | |
| Precautions10 | ASSEMBLY24 | |
| LIQUID GASKET APPLICATION PROCEDURE.....10 | INSPECTION.....25 | |
| Preparation10 | Overheating Cause Analysis26 | |
| SPECIAL SERVICE TOOLS10 | Service Data and Specifications (SDS).....27 | |
| Cooling Circuit11 | THERMOSTAT27 | |
| System Check.....12 | WATER CONTROL VALVE27 | |
| CHECKING COOLING SYSTEM HOSES.....12 | RADIATOR.....27 | |
| CHECKING RADIATOR.....12 | | |

ENGINE LUBRICATION SYSTEM

Precautions

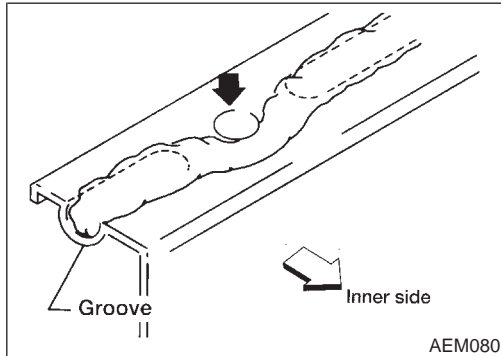
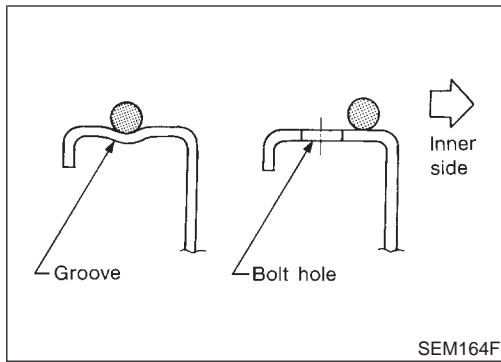

Precautions

LIQUID GASKET APPLICATION PROCEDURE

NALC0001

1. Use a scraper to remove all traces of old liquid gasket from mating surfaces and grooves. Also, completely clean any oil from these areas.
2. Apply a continuous bead of liquid gasket to mating surfaces. **(Use Genuine RTV silicone sealant or equivalent. Refer to GI-51.)**
 - For oil pan, be sure liquid gasket diameter is 4.0 to 5.0 mm (0.157 to 0.197 in).
 - For areas except oil pan, be sure liquid gasket diameter is 2.0 to 3.0 mm (0.079 to 0.118 in).
3. Apply liquid gasket around the inner side of bolt holes (unless otherwise specified).
4. Assembly should be done within 5 minutes after coating.
5. Wait at least 30 minutes before refilling engine oil and engine coolant.

Preparation

SPECIAL SERVICE TOOLS

NALC0002

The actual shapes of Kent-Moore tools may differ from those of special service tools illustrated here.

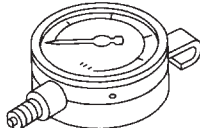
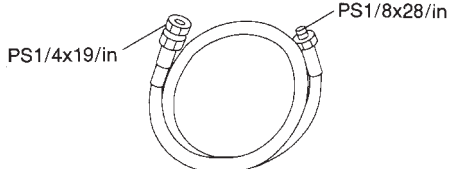
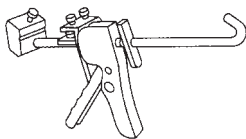
| Tool number (Kent-Moore No.) Tool name | Description |
|--|--|
| ST25051001 (J25695-1) Oil pressure gauge |  NT050 |
| ST25052000 (J25695-2) Hose |  NT559 |
| WS39930000 () Tube pressure |  NT052 |

ENGINE LUBRICATION SYSTEM

Preparation (Cont'd)

COMMERCIAL SERVICE TOOL

NALC0040

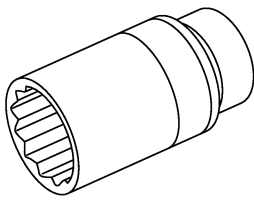
| Tool name | Description |
|-------------|--|
| Deep socket | <p>Removing and installing oil pressure switch Deep socket 26 mm, 3/8 drive</p>  <p>NT818</p> |

GI
MA
EM
LC
EC
FE
CL
MT
AT
TF
PD
AX
SU
BR
ST
RS
BT
HA
SC
EL
IDX

Lubrication Circuit

NALC0003

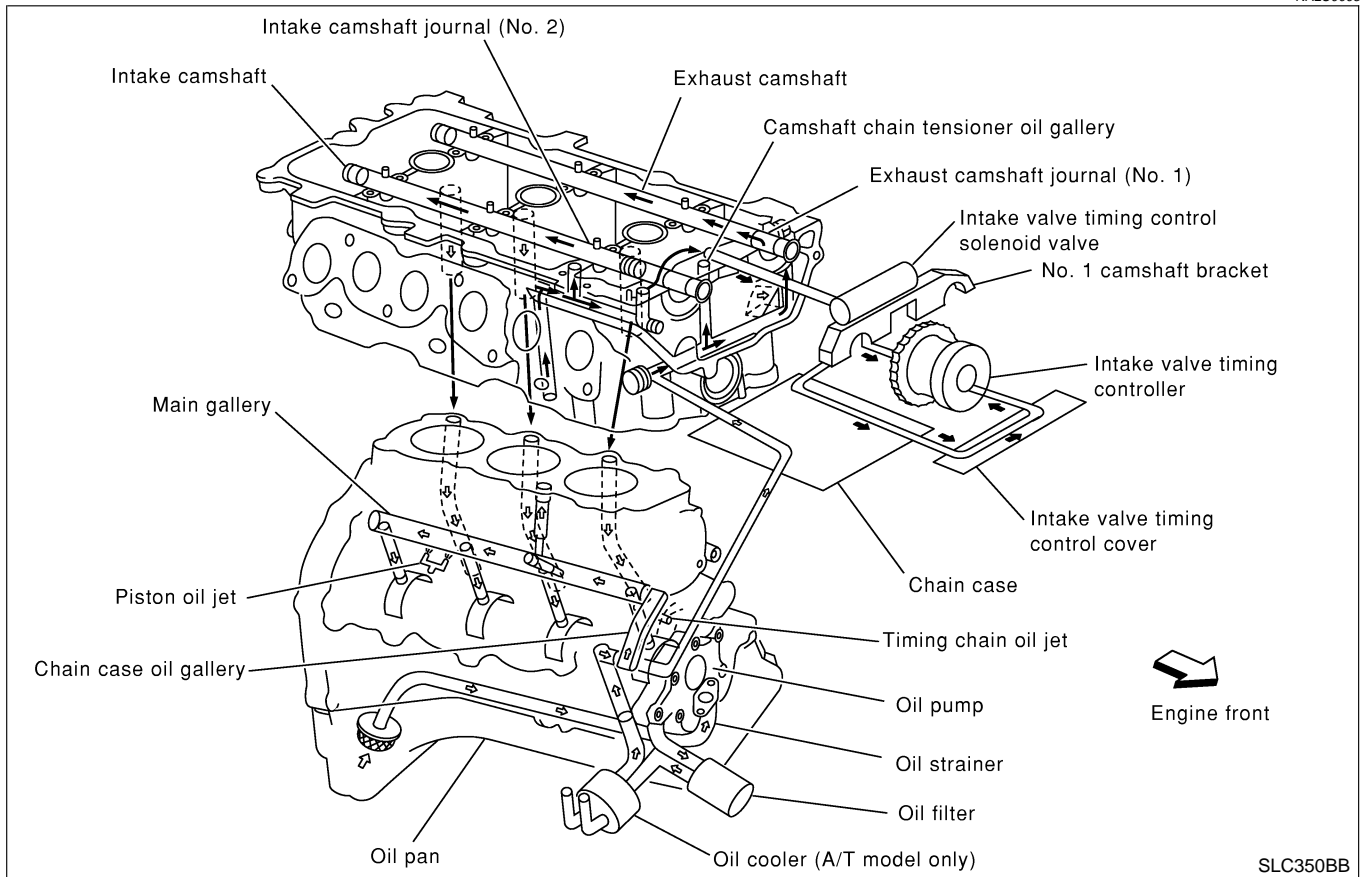

SLC350BB

ENGINE LUBRICATION SYSTEM

Lubrication Circuit (Cont'd)

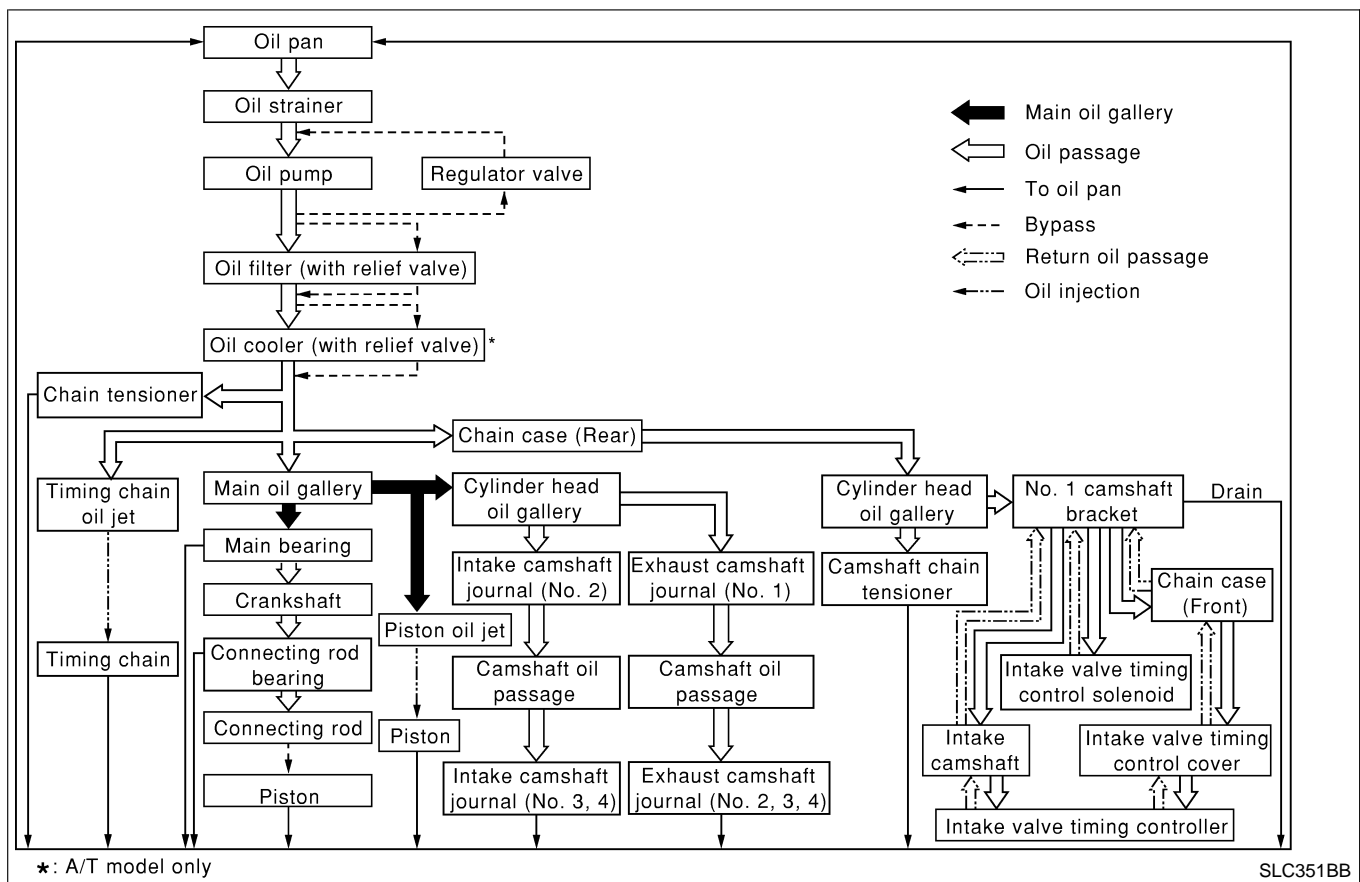

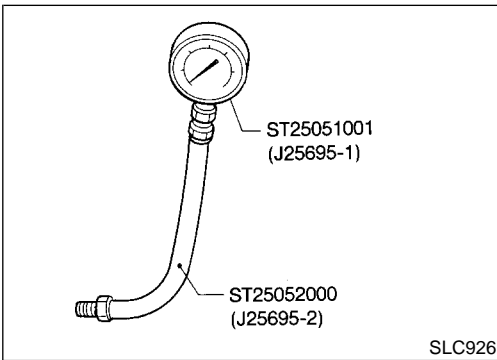
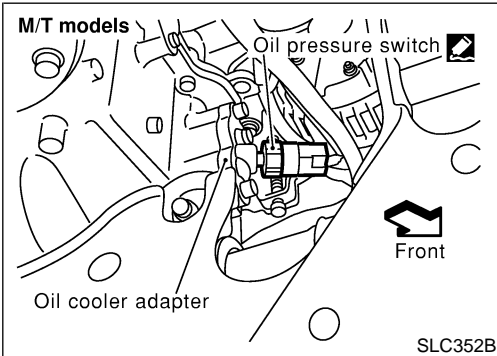
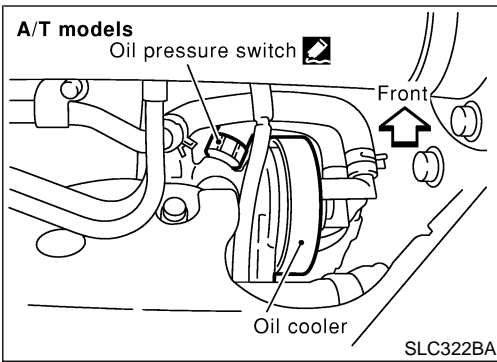

Oil Pressure Check

WARNING:

- Be careful not to burn yourself, as the engine and oil may be hot.
 - Oil pressure check should be done in “Neutral position” (M/T) or “Parking position” (A/T).
1. Check oil level.
 2. Disconnect oil pressure switch harness connector.
 3. Remove oil pressure switch using a deep socket. (Commercial service tool)
 4. Install pressure gauge.
 5. Start engine and warm it up to normal operating temperature.
 6. Check oil pressure with engine running under no-load.

| Engine speed rpm | Approximate discharge pressure kPa (kg/cm ² , psi) |
|---------------------|---|
| Idle speed 2,000 | More than 98 (1.0, 14) 294 (3.0, 43) |

If difference is extreme, check oil passage and oil pump for oil leaks.

7. After the inspections, install the oil pressure switch as follows.
 - a. Remove the old sealant adhering to switch and engine.
 - b. Apply Genuine RTV silicone sealant or equivalent to the thread and tighten. Refer to GI-51.

13 - 17 N·m (1.25 - 1.75 kg·m, 9 - 12 ft·lb)

GI
MA
EM
LC
EC
FE
CL
MT
AT
TF
PD
AX
SU
BR
ST
RS
BT
HA
SC
EL
IDX

ENGINE LUBRICATION SYSTEM

Oil Pump

REMOVAL AND INSTALLATION

=NALC0005

1. Remove timing chain. Refer to EM-23, "Removal".
2. Remove oil pump assembly.
 - Inspect the oil pump after removing it.
3. Reinstall any parts removed in reverse order of removal.

DISASSEMBLY AND ASSEMBLY

NALC0006

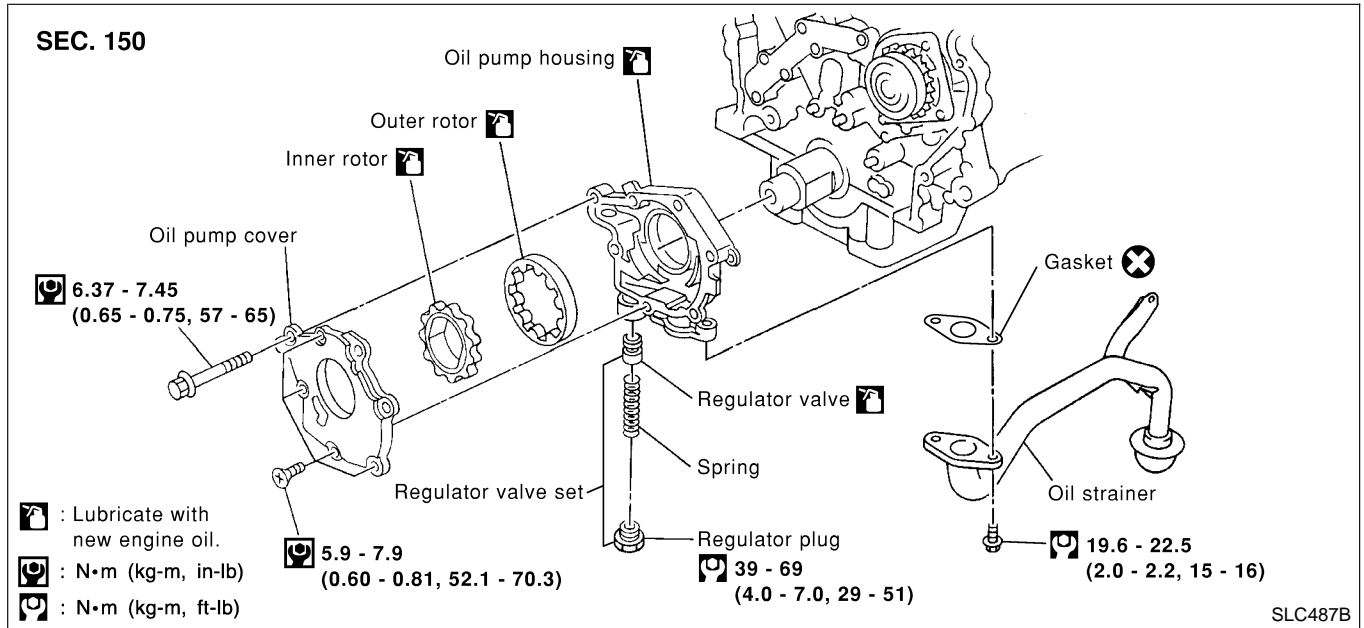

- When installing oil pump, apply engine oil to rotors.

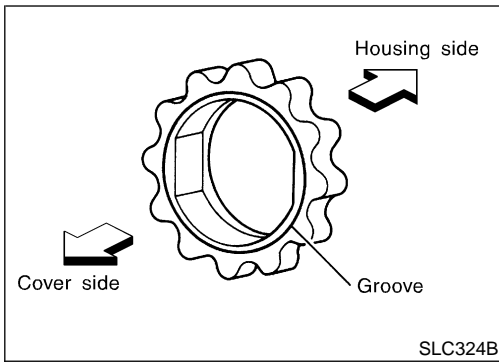

OIL PUMP INSPECTION

NALC0007

- Install oil pump with the groove of the inner rotor facing the oil pump cover.

Using a feeler gauge, straightedge and micrometers, check the following clearances:

Unit: mm (in)

| | |
|--|---------------------------------|
| Body to outer rotor radial clearance 1 | 0.114 - 0.200 (0.0045 - 0.0079) |
| Inner rotor to outer gear tip clearance 2 | Below 0.18 (0.0071) |
| Body to inner rotor axial clearance 3 | 0.030 - 0.070 (0.0012 - 0.0028) |
| Body to outer rotor axial clearance 4 | 0.050 - 0.110 (0.0020 - 0.0043) |
| Inner rotor to brazed portion of housing clearance 5 | 0.045 - 0.091 (0.0018 - 0.0036) |

- If the tip clearance (2) exceeds the limit, replace rotor set.
- If body to rotor clearances (1, 3, 4, 5) exceed the limit, replace oil pump body assembly.

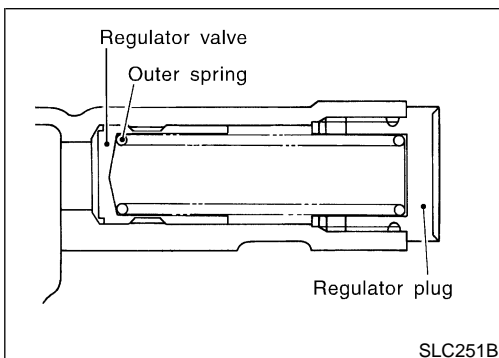
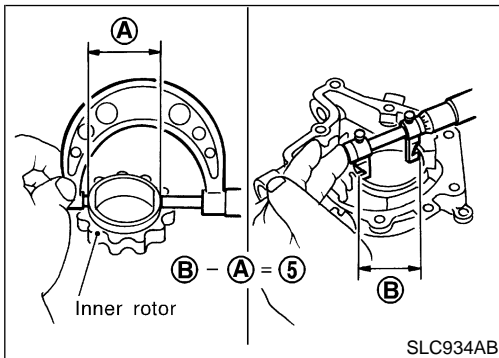
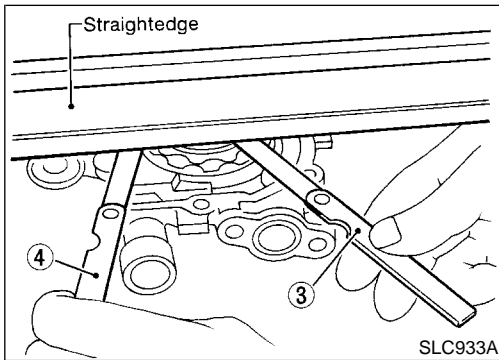
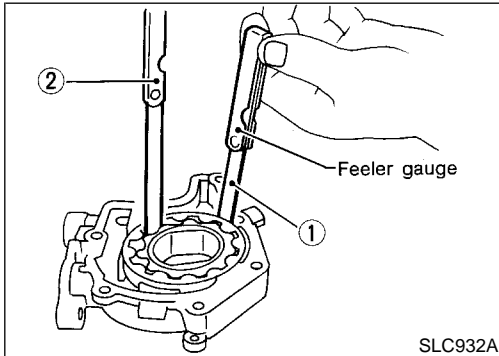

REGULATOR VALVE INSPECTION

NALC0008

1. Visually inspect components for wear and damage.
2. Check oil pressure regulator valve sliding surface and valve spring.
3. Coat regulator valve with engine oil. Check that it falls smoothly into the valve hole by its own weight.

If damaged, replace regulator valve set or oil pump body.

GI
MA
EM
LC
EC
FE
CL
MT
AT
TF
PD
AX
SU
BR
ST
RS
BT
HA
SC
EL
IDX

ENGINE LUBRICATION SYSTEM

Oil Pump (Cont'd)

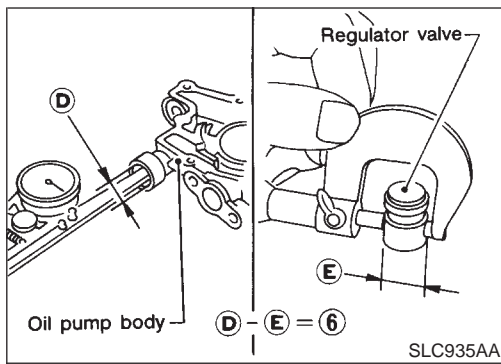

4. Check regulator valve to oil pump body clearance.

Clearance:

6 : 0.040 - 0.097 mm (0.0016 - 0.0038 in)

If it exceeds the limit, replace oil pump body.

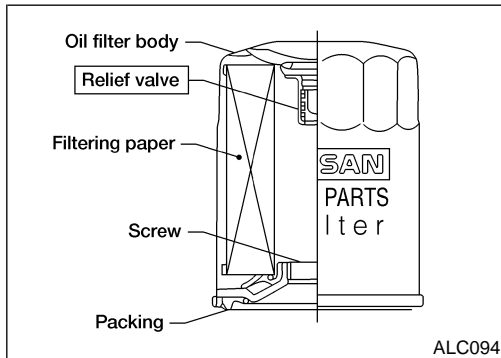

OIL FILTER

The oil filter is a small, full-flow cartridge type and is provided with a relief valve. NALC0009

- Use Tool specified in MA-19 for changing oil filter.

Oil Cooler

REMOVAL AND INSTALLATION

NALC0036

SEC. 150-213
A/T models

M/T models

: Apply liquid gasket (Genuine RTV silicone sealant Part No.999MP-A7007 or equivalent).
 : N•m (kg-m, ft-lb)

SLC353B

1. Drain engine oil and coolant.
 - Do not spill coolant on the drive belt.
2. Remove oil cooler.

- Inspect the oil cooler after removing it.

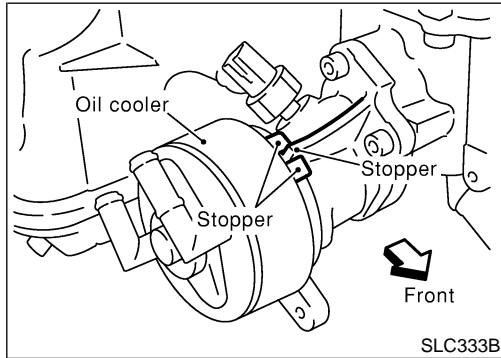

3. Installation is in reverse order of removal.
 - **When installing the oil cooler, align the oil cooler stopper with the stopper of the oil cooler bracket.**

INSPECTION

Oil Cooler

1. Check oil cooler for cracks.
2. Check oil cooler for clogging by blowing through coolant inlet. If necessary, replace oil cooler assembly.

Oil Pressure Relief Valve

Inspect oil pressure relief valve for movement, cracks and breaks by pushing the ball. If replacement is necessary, remove valve by prying it out with a suitable tool. Install a new valve in place by tapping it.

Service Data and Specifications (SDS)

OIL PRESSURE

| Engine speed rpm | Approximate discharge pressure kPa (kg/cm ² , psi) |
|---------------------|--|
| Idle speed 2,000 | More than 98 (1.0, 14) 294 (3.0, 43) |

REGULATOR VALVE

| | Unit: mm (in) |
|---|---------------------------------|
| Regulator valve to oil pump cover clearance | 0.040 - 0.097 (0.0016 - 0.0038) |

OIL PUMP

| | Unit: mm (in) |
|--|---------------------------------|
| Body to outer rotor radial clearance | 0.114 - 0.200 (0.0045 - 0.0079) |
| Inner rotor to outer rotor tip clearance | Below 0.18 (0.0071) |
| Body to inner rotor axial clearance | 0.030 - 0.070 (0.0012 - 0.0028) |
| Body to outer rotor axial clearance | 0.050 - 0.110 (0.0020 - 0.0043) |
| Inner rotor to brazed portion of housing clearance | 0.045 - 0.091 (0.0018 - 0.0036) |

ENGINE COOLING SYSTEM

Precautions

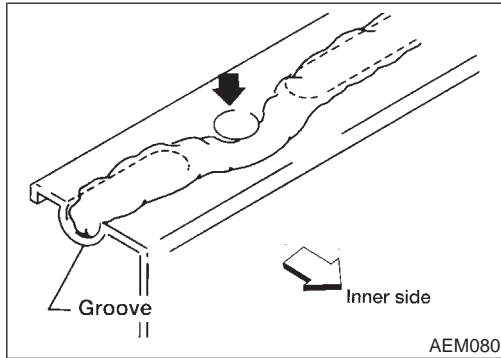
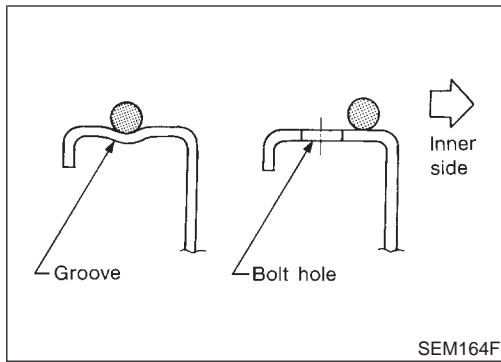

Precautions

LIQUID GASKET APPLICATION PROCEDURE

NALC0013



1. Use a scraper to remove all traces of old liquid gasket from mating surfaces and grooves. Also, completely clean any oil from these areas.
2. Apply a continuous bead of liquid gasket to mating surfaces. **(Use Genuine RTV silicone sealant or equivalent. Refer to GI-51.)**
 - For oil pan, be sure liquid gasket diameter is 4.0 to 5.0 mm (0.157 to 0.197 in).
 - For areas except oil pan, be sure liquid gasket diameter is 2.0 to 3.0 mm (0.079 to 0.118 in).
3. Apply liquid gasket around the inner side of bolt holes (unless otherwise specified).
4. Assembly should be done within 5 minutes after coating.
5. Wait at least 30 minutes before refilling engine oil and engine coolant.

Preparation

SPECIAL SERVICE TOOLS

NALC0014

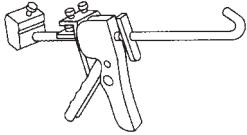
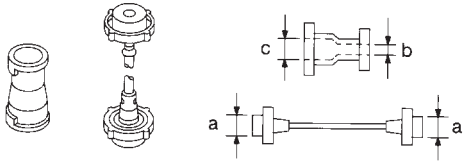
The actual shapes of Kent-Moore tools may differ from those of special service tools illustrated here.

| Tool number (Kent-Moore No.) Tool name | Description |
|--|---|
| WS39930000 (—) Tube pressure |  Pressing the tube of liquid gasket NT052 |
| EG17650301 (J33984-A) Radiator cap tester adapter |  Adapting radiator cap tester to radiator filler neck a: 28 (1.10) dia. b: 31.4 (1.236) dia. c: 41.3 (1.626) dia. Unit: mm (in) NT564 |
| KV99103510 (—) Radiator plate pliers A |  Installing radiator upper and lower tanks NT224 |
| KV99103520 (—) Radiator plate pliers B |  Removing radiator upper and lower tanks NT225 |

ENGINE COOLING SYSTEM

Cooling Circuit

Cooling Circuit

NALC0015

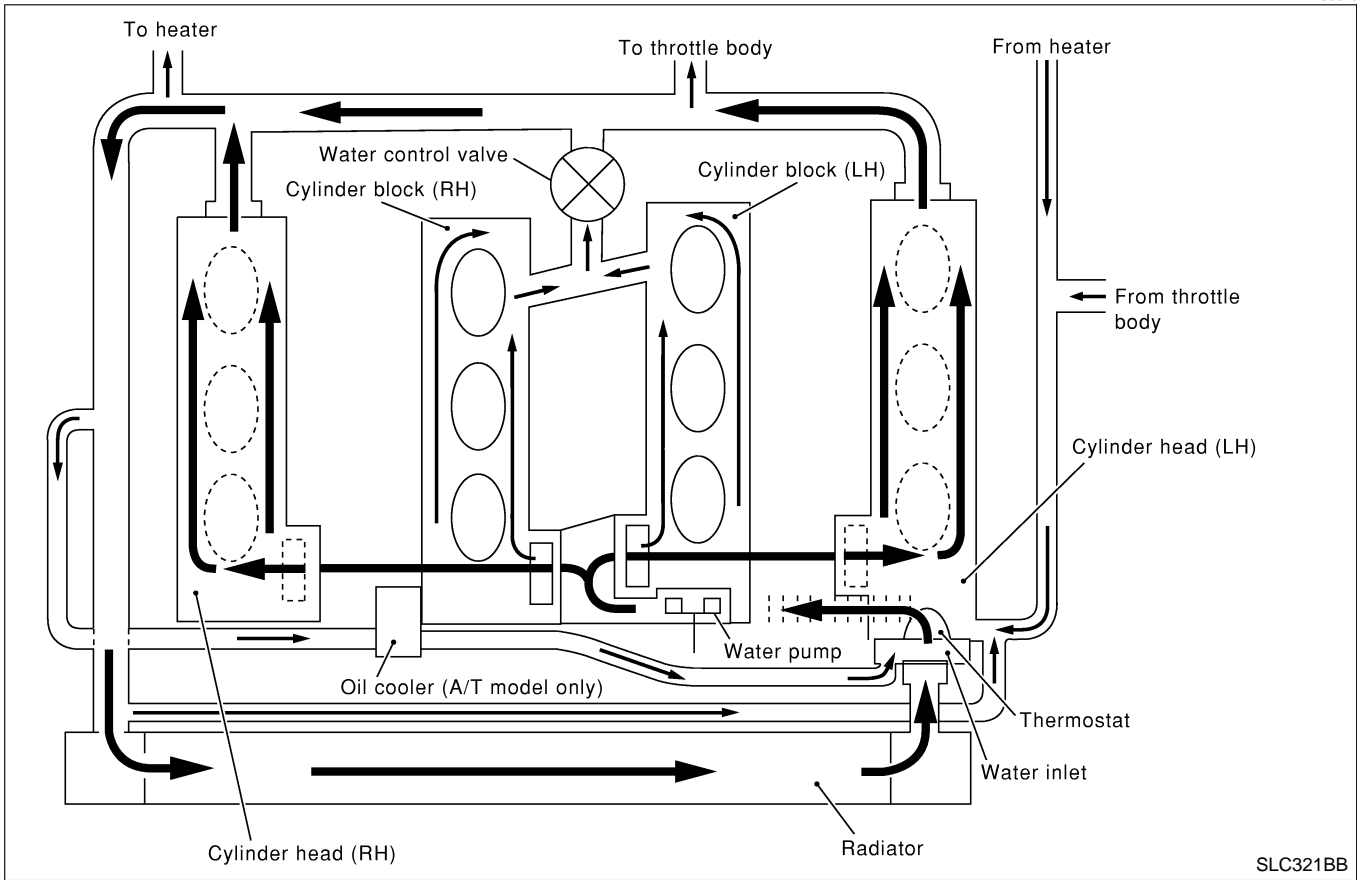

SLC321BB

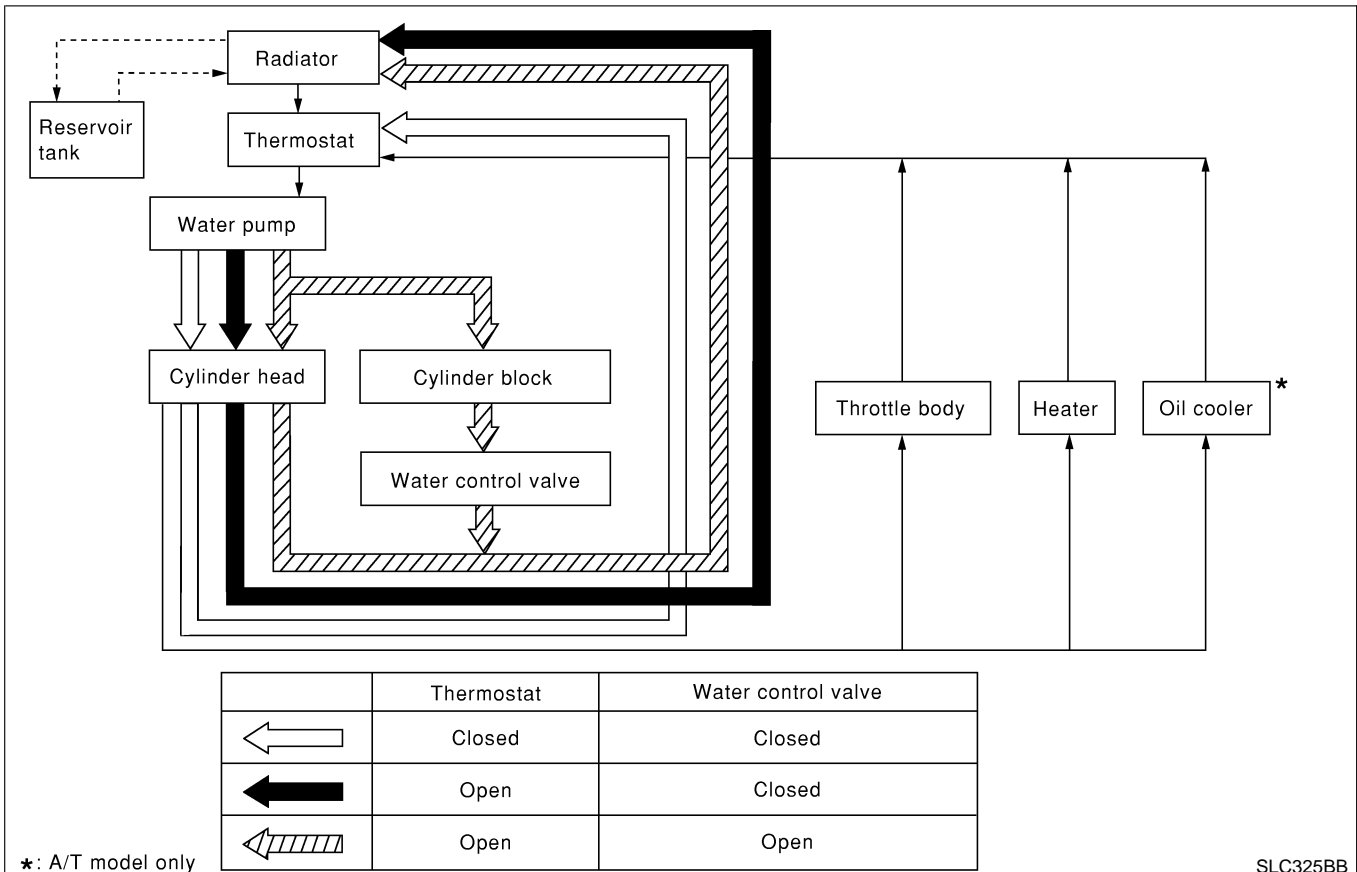

| | Thermostat | Water control valve |
|--|------------|---------------------|
| | Closed | Closed |
| | Open | Closed |
| | Open | Open |

*: A/T model only

SLC325BB

GI
MA
EM
LC
EC
FE
CL
MT
AT
TF
PD
AX
SU
BR
ST
RS
BT
HA
SC
EL
IDX

System Check

NALC0016

WARNING:

Never remove the radiator cap when the engine is hot; serious burns could be caused by high pressure fluid escaping from the radiator.

Wrap a thick cloth around the cap and carefully remove it by turning it a quarter turn to allow built-up pressure to escape and then turn the cap all the way off.

CHECKING COOLING SYSTEM HOSES

NALC0016S01

Check hoses for improper attachment, leaks, cracks, damage, loose connections, chafing and deterioration.

CHECKING RADIATOR

NALC0016S02

Check radiator for mud or clogging. If necessary, clean radiator as follows.

- Be careful not to bend or damage the radiator fins.
 - When radiator is cleaned without removal, remove all surrounding parts such as cooling fan, radiator shroud and horns. Then tape the harness and connectors to prevent water from entering.
1. Apply water by hose to the back side of the radiator core vertically downward.
 2. Apply water again to all radiator core surfaces once per minute.
 3. Stop washing if any stains no longer flow out from the radiator.
 4. Blow air into the back side of radiator core vertically downward.
- Use compressed air lower than 490 kPa (5 kg/cm², 71 psi) and keep distance more than 30 cm (11.8 in).
5. Blow air again into all the radiator core surfaces once per minute until no water sprays out.

CHECKING RADIATOR CAP

NALC0016S03

To check radiator cap, apply pressure to cap with a tester.

Radiator cap relief pressure:

Standard

78 - 98 kPa

(0.8 - 1.0 kg/cm², 11 - 14 psi)

Limit

59 kPa (0.6 kg/cm², 9 psi)

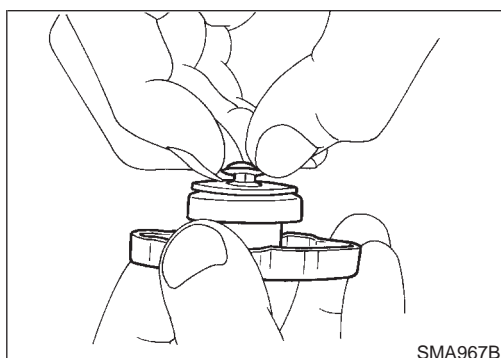
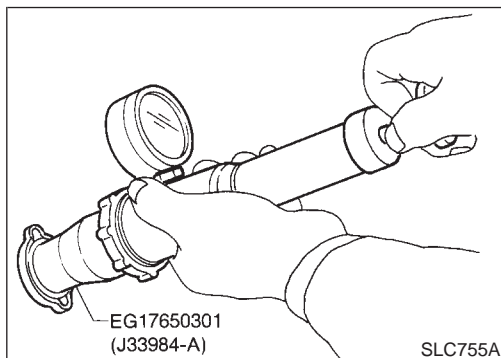

Pull the negative pressure valve to open it. Check that it closes completely when released.

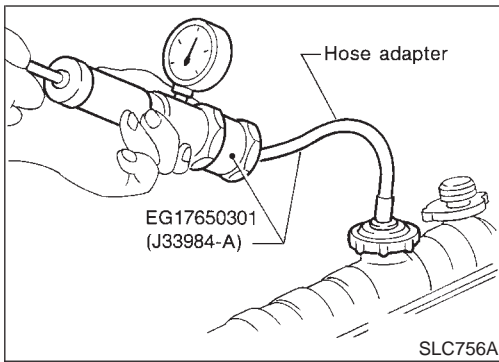

CHECKING COOLING SYSTEM FOR LEAKS

NALC0016S04

To check for leakage, apply pressure to the cooling system with a tester.

Testing pressure:
157 kPa (1.6 kg/cm², 23 psi)

CAUTION:
Higher than the specified pressure may cause radiator damage.

Water Pump

REMOVAL AND INSTALLATION

NALC0017

- CAUTION:**
- When removing water pump assembly, be careful not to get coolant on drive belt.
 - Water pump cannot be disassembled and should be replaced as a unit.
 - After installing water pump, connect hose and clamp securely, then check for leaks using radiator cap tester.

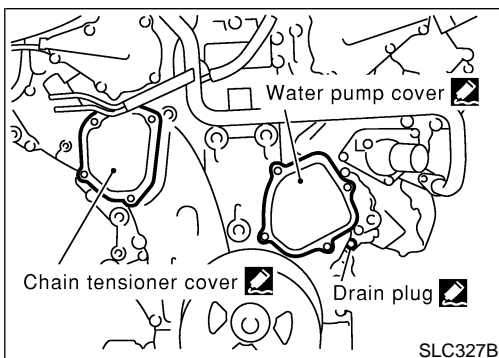
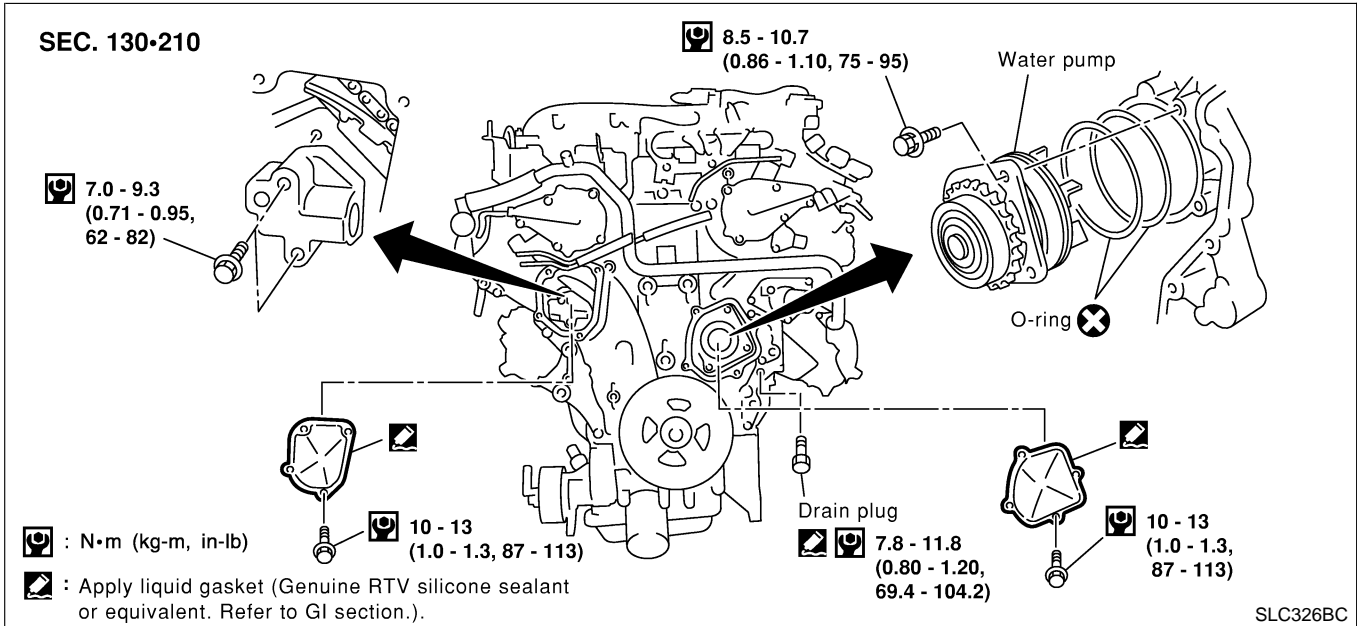

REMOVAL

NALC0018

1. Remove undercover.
2. Remove suspension member stay.
3. Drain coolant from radiator.
4. Remove radiator shrouds.
5. Remove drive belts.
6. Remove cooling fan.
7. Remove water drain plug on water pump side of cylinder block.
8. Remove chain tensioner cover and water pump cover.

ENGINE COOLING SYSTEM

Water Pump (Cont'd)

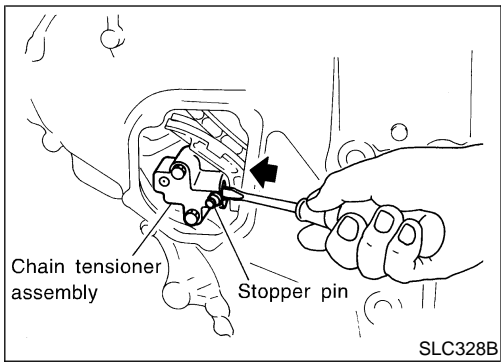

9. Pushing timing chain tensioner sleeve, apply a stopper pin so it does not return. Then remove the chain tensioner assembly.

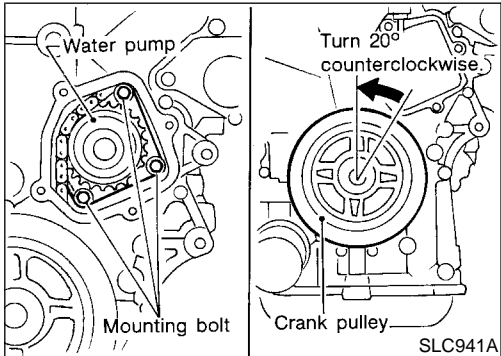

10. Remove the 3 water pump fixing bolts. Secure a gap between water pump gear and timing chain, by turning crankshaft pulley 20° backwards.

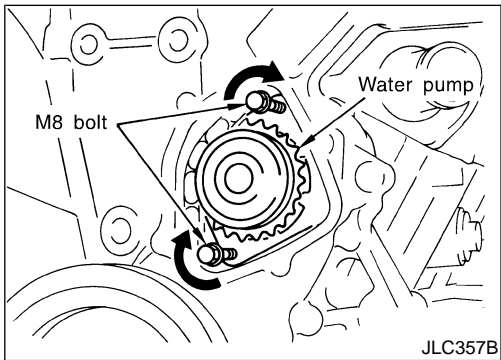

11. Put M8 bolts to two water pump fixing bolt holes.

ENGINE COOLING SYSTEM

Water Pump (Cont'd)

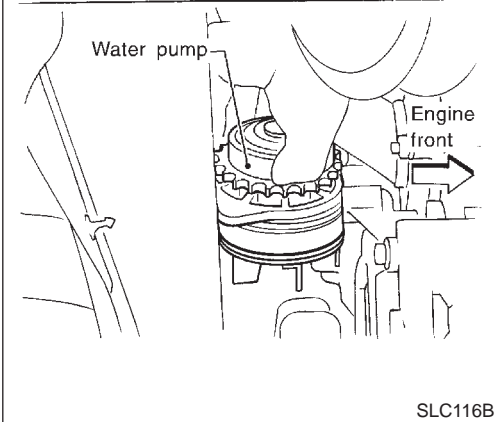
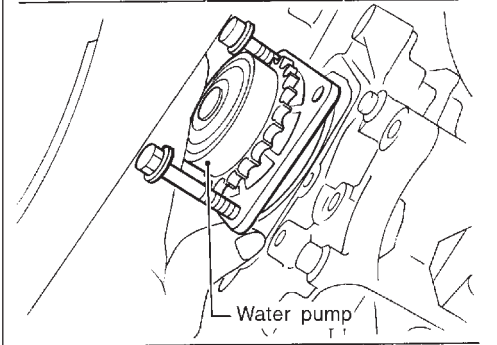
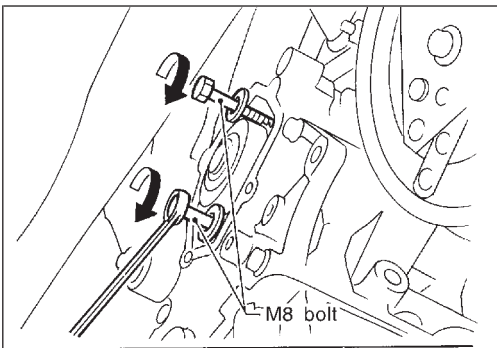

SLC116B

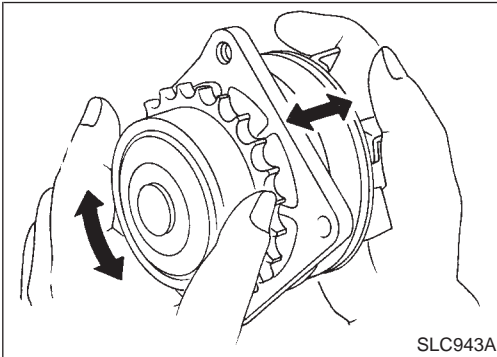

12. Tighten M8 bolts by turning half turn alternately until they reach timing chain rear case.
 - In order to prevent damages to water pump or timing chain rear case, do not tighten one bolt continuously. Always turn each bolt half turn each time.
13. Lift up water pump and remove it.
 - When lifting up water pump, do not allow water pump gear to hit timing chain.

INSPECTION

1. Check for badly rusted or corroded body assembly.
2. Check for rough operation due to excessive end play.

NALC0019

GI
MA
EM
LC
EC
FE
CL
MT
AT
TF
PD
AX
SU
BR
ST
RS
BT
HA
SC
EL
IDX

ENGINE COOLING SYSTEM

Water Pump (Cont'd)

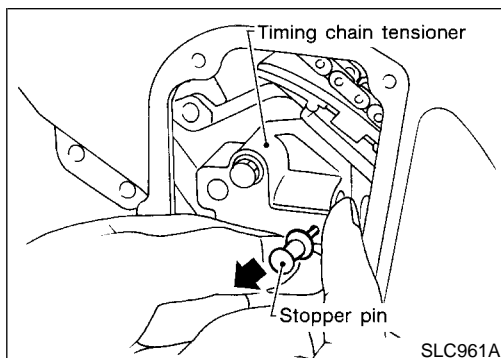
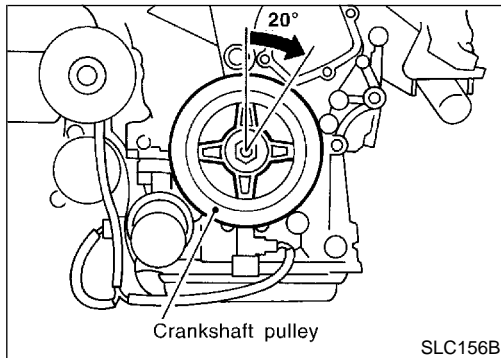
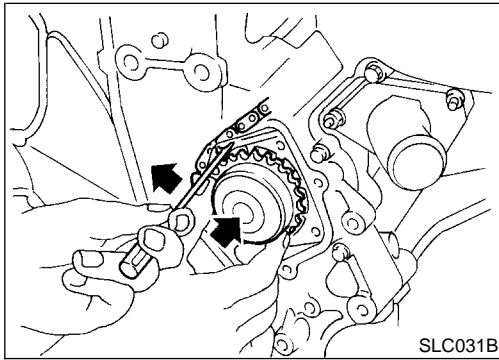
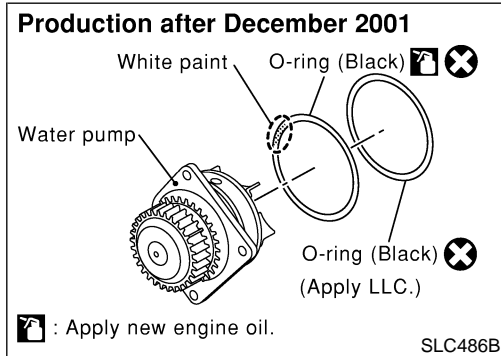
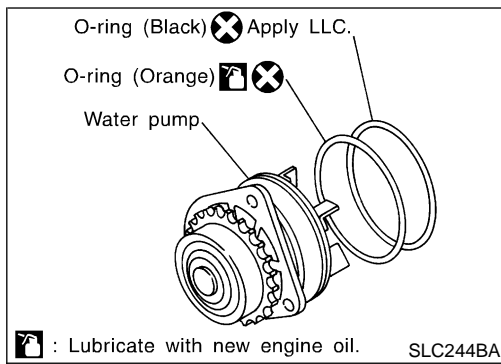

INSTALLATION

1. Apply engine oil and coolant to O-rings as shown in the figure. =NALC0020

- On models with two black O-rings, install the one with a white paint mark to the front side.

2. Install water pump.

- **Do not allow cylinder block to nip O-rings when installing water pump.**

3. Return the crankshaft pulley to its original position by turning it 20° forward.

4. Install timing chain tensioner, then remove the stopper pin.

- **When installing the timing chain tensioner, engine oil should be applied to the oil hole and tensioner.**

ENGINE COOLING SYSTEM

Water Pump (Cont'd)

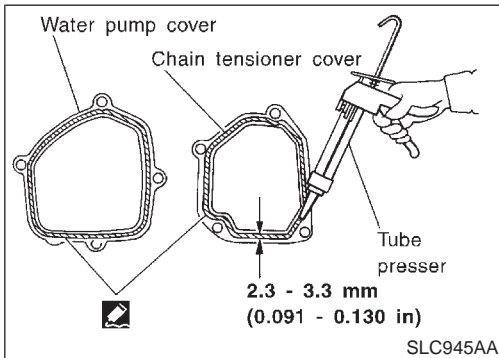
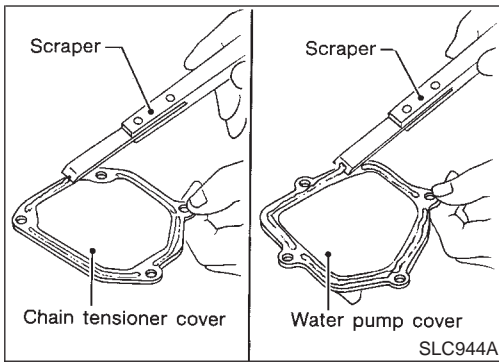

5. Install chain tensioner cover and water pump cover.
 - a. Before installing, remove all traces of liquid gasket from mating surface of water pump cover and chain tensioner cover using a scraper. Also remove traces of liquid gasket from mating surface of front cover.
 - b. Apply a continuous bead of liquid gasket to mating surface of chain tensioner cover and water pump cover. **Use Genuine RTV silicone sealant or equivalent. Refer to GI-51.**
6. Reinstall any parts removed in reverse order of removal.
 - After starting engine, let idle for three minutes, then rev engine up to 3,000 rpm under no load to purge air from the high-pressure chamber of the chain tensioners. The engine may produce a rattling noise. This indicates that air still remains in the chamber and is not a matter of concern.

GI
MA
EM
LC
EC
FE
CL
MT
AT
TF
PD
AX
SU
BR
ST
RS
BT
HA
SC
EL
IDX

ENGINE COOLING SYSTEM

Thermostat

Thermostat REMOVAL AND INSTALLATION

=NALC0021

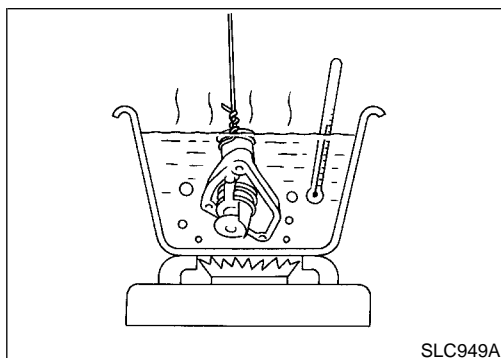
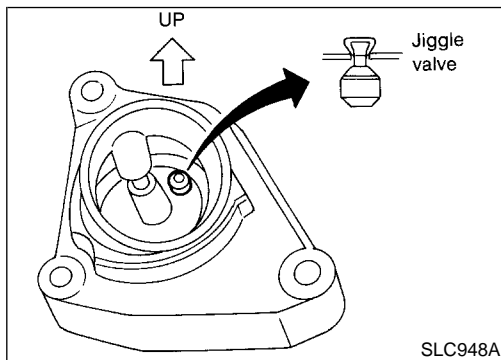
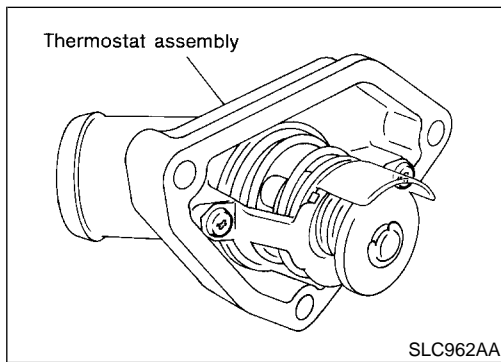
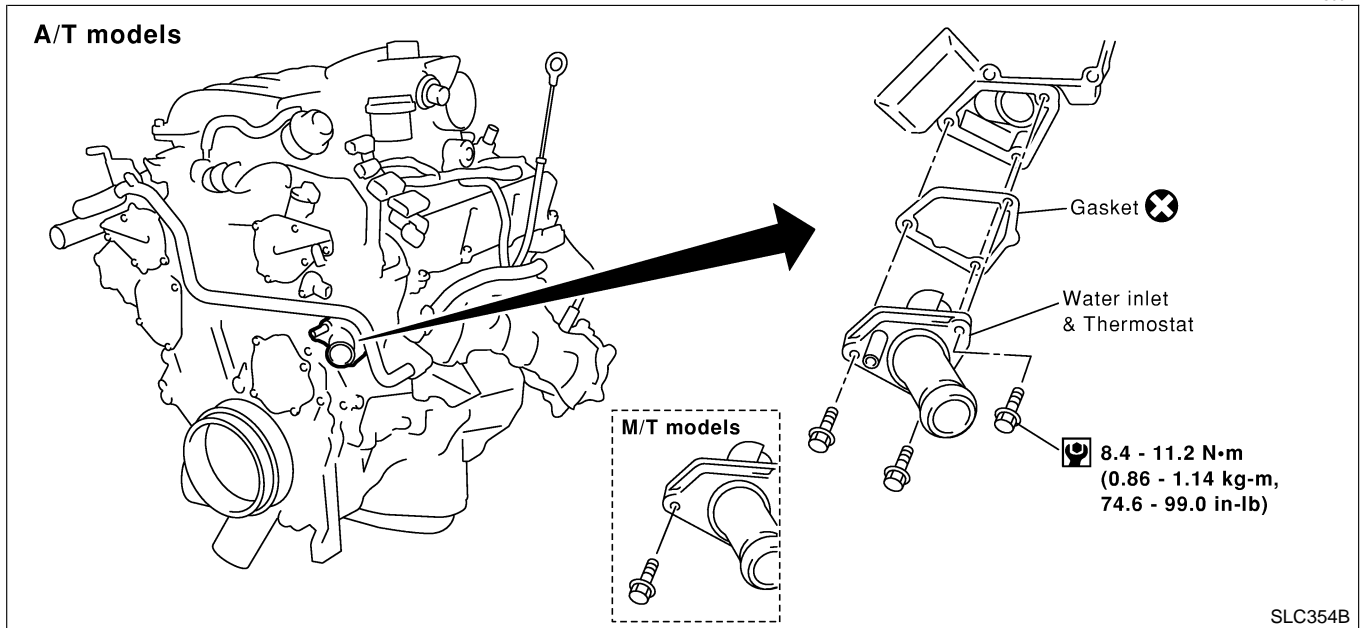

1. Remove undercover.
2. Remove suspension member stay.
3. Drain coolant from radiator.
4. Remove drive belts.
5. Remove water drain plug on water pump side of cylinder block.
6. Disconnect lower radiator hose.
7. Remove water inlet and thermostat assembly.
- **Do not disassemble water inlet and thermostat. Replace them as a unit, if necessary.**
8. Install thermostat with jiggle valve facing upward.
- **After installation, run engine for a few minutes, and check for leaks.**
- **Be careful not to spill coolant over engine compartment. Use a rag to absorb coolant.**
9. Reinstall any removed parts in reverse order of removal.

INSPECTION

NALC0022

1. Check valve seating condition at ordinary room temperatures. It should seat tightly.
2. Check valve opening temperature and maximum valve lift.

| | |
|---------------------------|---|
| | Standard |
| Valve opening temperature | 76.5°C (170°F) |
| Valve lift | More than 8.6 mm/90°C (0.339 in/194°F) |

3. Then check if valve closes at 5°C (9°F) below valve opening

temperature.

GI

MA

EM

LC

EC

Water Control Valve REMOVAL AND INSTALLATION

NALC0032

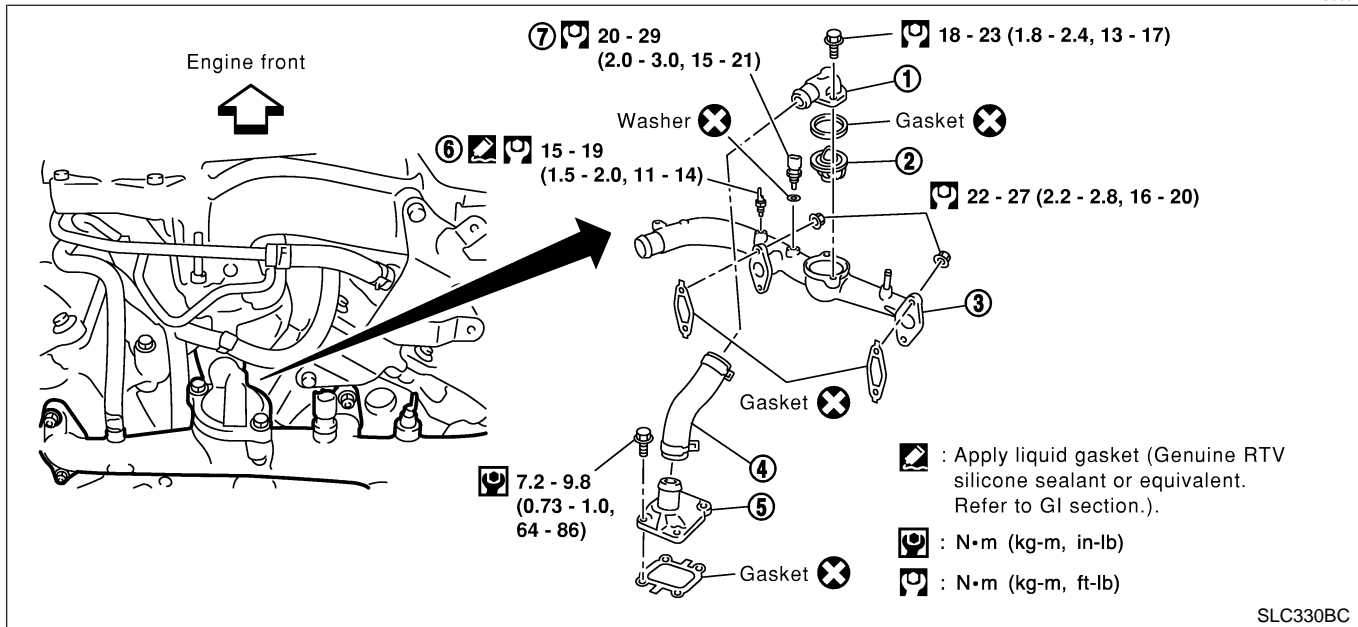

FE

CL

MT

AT

TF

PD

AX

SU

- | | | |
|-------------------------|--------------------------------|--------------------------------------|
| 1. Water outlet housing | 4. Water hose | 7. Engine coolant temperature sensor |
| 2. Water control valve | 5. Cylinder block water outlet | |
| 3. Water outlet | 6. Thermal transmitter | |

BR

1. Release fuel pressure. Refer to EC-51, "Fuel Pressure Release".
2. Remove undercover.
3. Remove suspension member stay.
4. Drain coolant from radiator.
5. Remove engine cover.
6. Remove air duct with air cleaner assembly.
7. Disconnect wires, hoses, harness and so on.
8. Remove upper intake manifold corrector.
9. Remove intake manifold corrector support bolts.
10. Remove lower intake manifold corrector.
11. Disconnect injector harness connectors.
12. Remove injector tube.
13. Remove intake manifold.
14. Remove water outlet housing and water control valve.

ST

RS

BT

HA

SC

EL

IDX

ENGINE COOLING SYSTEM

Water Control Valve (Cont'd)

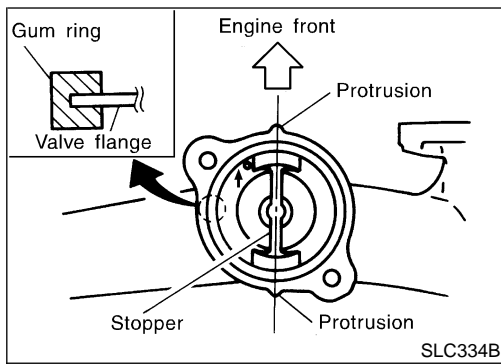

15. Install water control valve and water outlet housing.
 - a. Install gum ring to thermostat.
 - b. Point the arrow on the upper surface of the valve to the front of the engine, and also be sure to install the protrusions and the valve stopper so that they are aligned in a straight line.
16. Reinstall any removed parts in reverse order of removal.
 - **When installing intake manifold, injector tube and intake manifold collectors, refer to EM-12, "TIGHTENING PROCEDURES".**
 - **After installation, run engine for a few minutes, and check for leaks.**
 - **Be careful not to spill coolant over engine compartment. Use a rag to absorb coolant.**

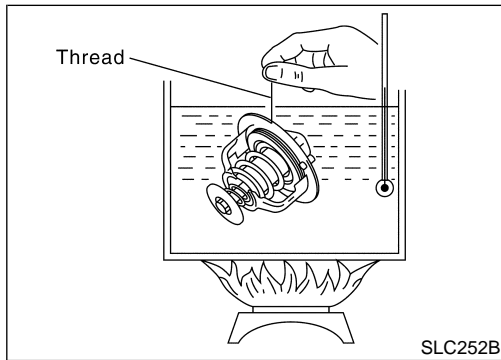

INSPECTION

NALC0033

1. Check valve seating condition at ordinary room temperatures. It should seat tightly.
2. Check valve opening temperature and maximum valve lift.

| | Standard |
|---------------------------|--|
| Valve opening temperature | 95°C (203°F) |
| Valve lift | More than 8.0 mm/108°C (0.315 in/226°F) |

3. Then check if valve closes at 5°C (9°F) below valve opening temperature.

Radiator

REMOVAL AND INSTALLATION

1. Remove undercover.
2. Remove suspension member stay.
3. Drain coolant from radiator.
4. Disconnect radiator upper and lower hoses.
5. Remove upper and lower radiator shroud.
6. Remove A/T oil cooler hoses. (A/T)
7. Disconnect reservoir tank hose.
8. Remove radiator mounting bracket.
9. Remove radiator.
10. After repairing or replacing radiator, install any part removed in reverse order of removal.

=NALC0023

When filling radiator with coolant, refer to MA-15, "Changing Engine Coolant".

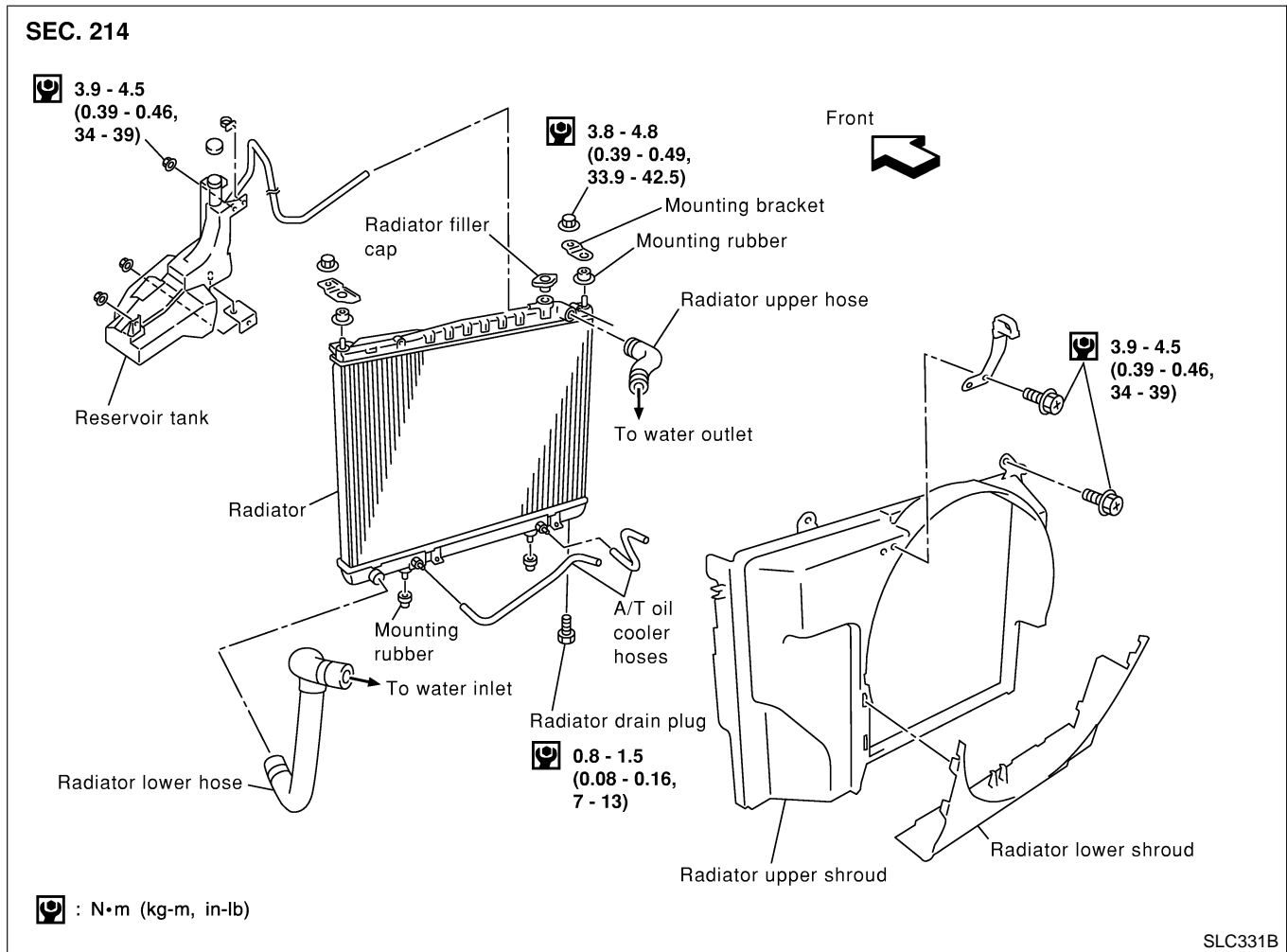

GI
MA
EM
LC
EC
FE
CL
MT
AT
TF
PD
AX
SU
BR
ST
RS
BT
HA
SC
EL
IDX

ENGINE COOLING SYSTEM

Cooling Fan (Crankshaft driven)

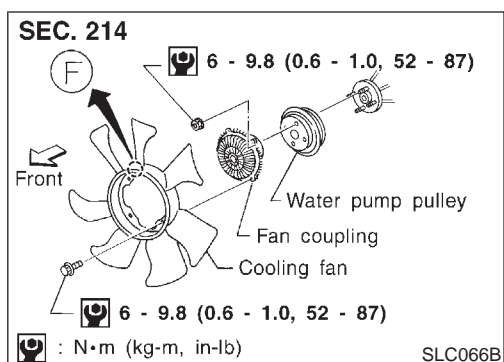

Cooling Fan (Crankshaft driven)

REMOVAL AND INSTALLATION

=NALC0038

- Do not release the drive belt tension by removing the fan/water pump pulley.
- Fan coupling cannot be disassembled and should be replaced as a unit. If front mark **F** is present, install fan so that side marked **F** faces the front.
- Install the drive belt only after the fan and fan coupling to water pump flange bolts/nuts have been properly torqued.
- Proper alignment of these components is essential. Improper alignment will cause them to wobble and may eventually cause the fan to separate from the water pump causing extensive damage.

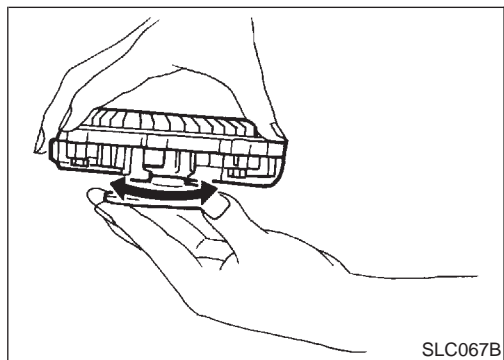

INSPECTION

NALC0039

Check fan coupling for rough operation, wobbling, oil leakage or bent bimetal.

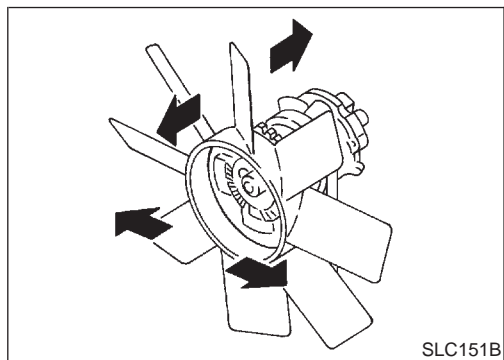

After assembly, verify the fan does not wobble or flap while the engine is running.

WARNING:

- When the engine is running, keep hands and clothing away from moving parts such as drive belts and fan.

Refilling Engine Coolant

NALC0034

For details on refilling engine coolant, refer to MA-16, "REFILLING ENGINE COOLANT".

Radiator (Aluminum type) PREPARATION

NALC0025

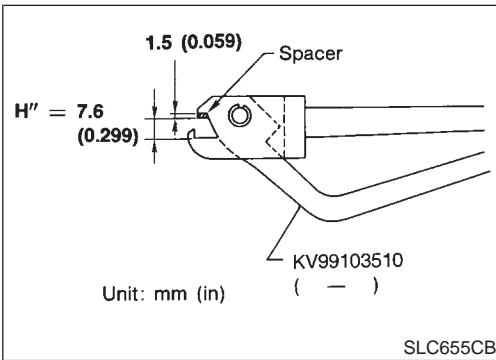
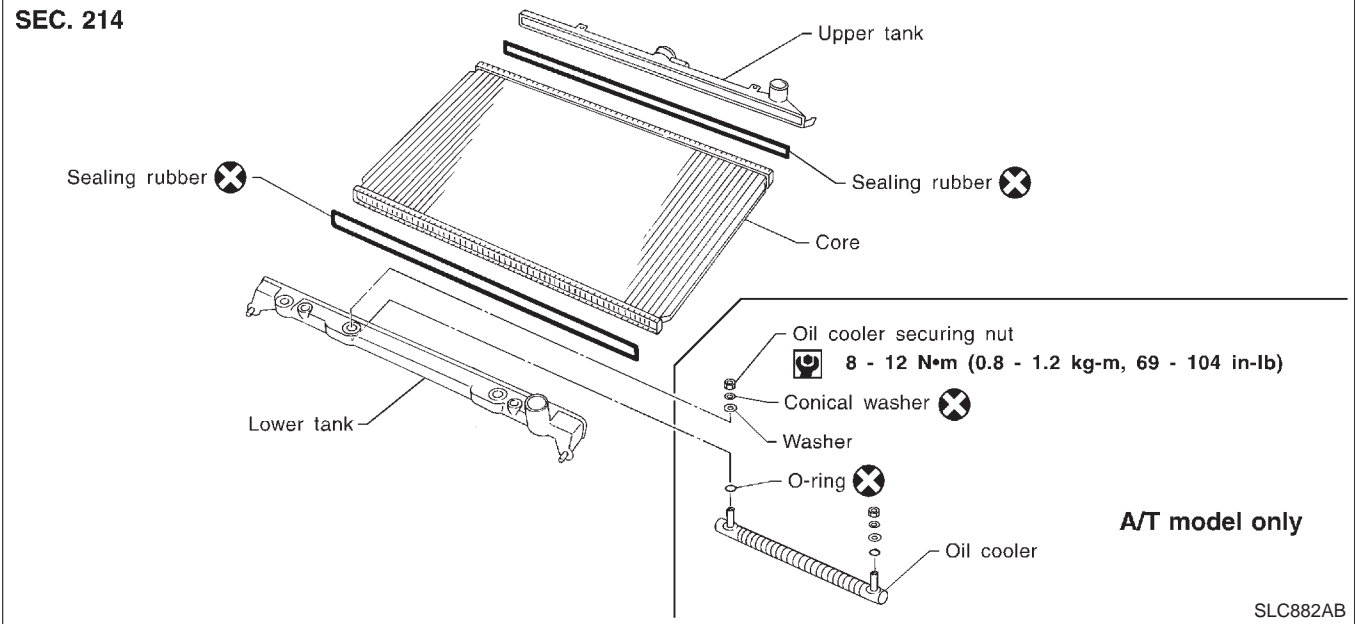

1. Attach the spacer to the tip of the radiator plate pliers A. Spacer specification: 1.5 mm (0.059 in) thick x 18 mm (0.71 in) wide x 8.5 mm (0.335 in) long.
2. Make sure that when radiator plate pliers A are closed dimension H'' is approx. 7.6 mm (0.299 in).
3. Adjust dimension H'' with the spacer, if necessary.

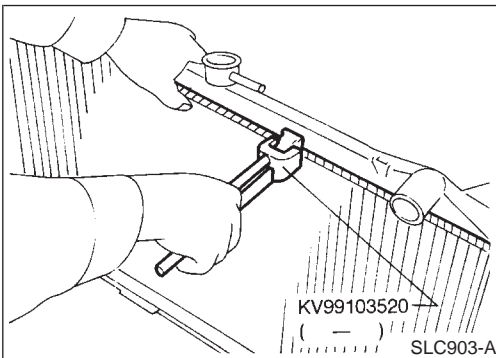

DISASSEMBLY

NALC0026

1. Remove tank with Tool.

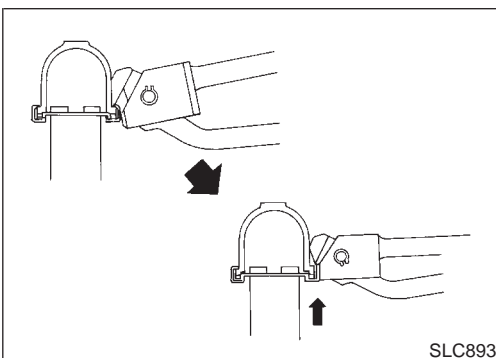

- Grip the crimped edge and bend it upwards so that Tool slips off.

Do not bend excessively.

GI
MA
EM
LC
EC
FE
CL
MT
AT
TF
PD
AX
SU
BR
ST
RS
BT
HA
SC
EL
IDX

ENGINE COOLING SYSTEM

Radiator (Aluminum type) (Cont'd)

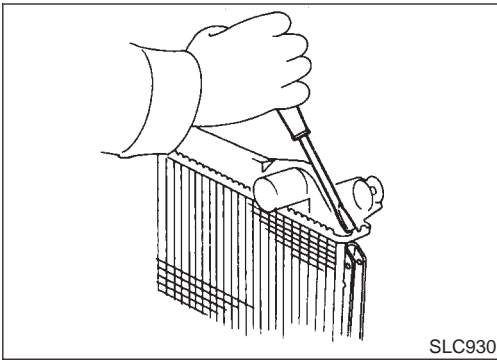

- In areas where Tool cannot be used, use a screwdriver to bend the edge up.

Be careful not to damage tank.

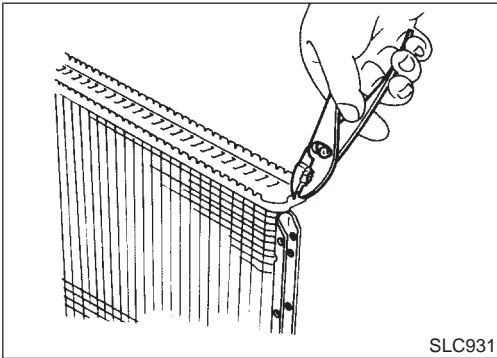

2. Make sure the edge stands straight up.
3. Remove oil cooler from tank.

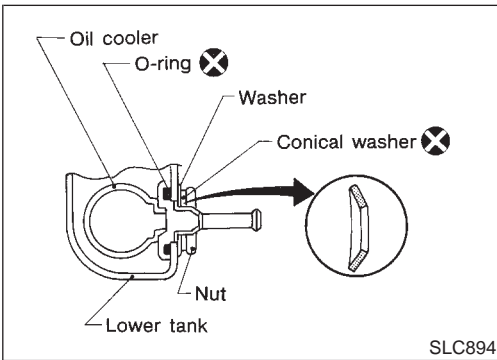

ASSEMBLY

1. Install oil cooler.

Pay attention to direction of conical washer.

NALC0027

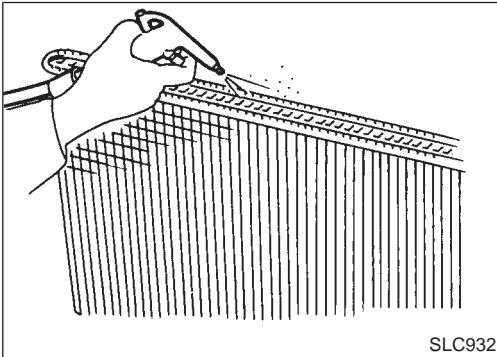

2. Clean contact portion of tank.

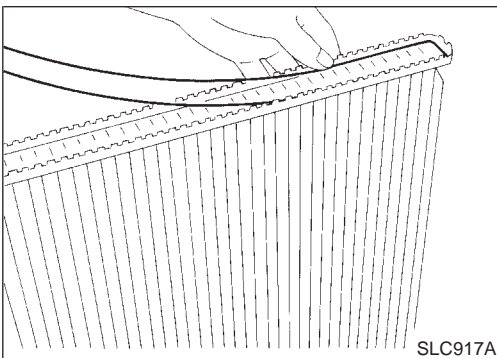

3. Install sealing rubber.

Push it in with fingers.

Be careful not to twist sealing rubber.

ENGINE COOLING SYSTEM

Radiator (Aluminum type) (Cont'd)

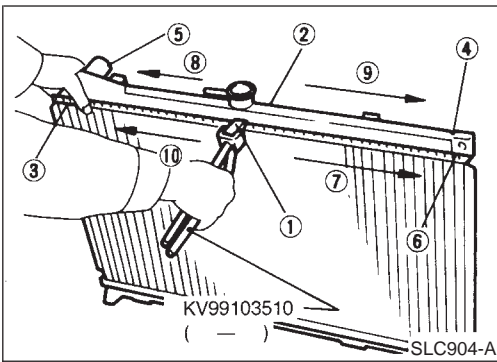

4. Caulk tank in specified sequence with Tool.

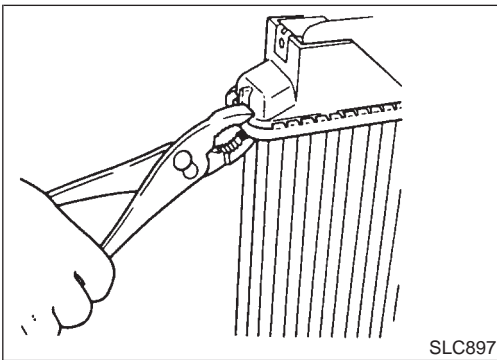
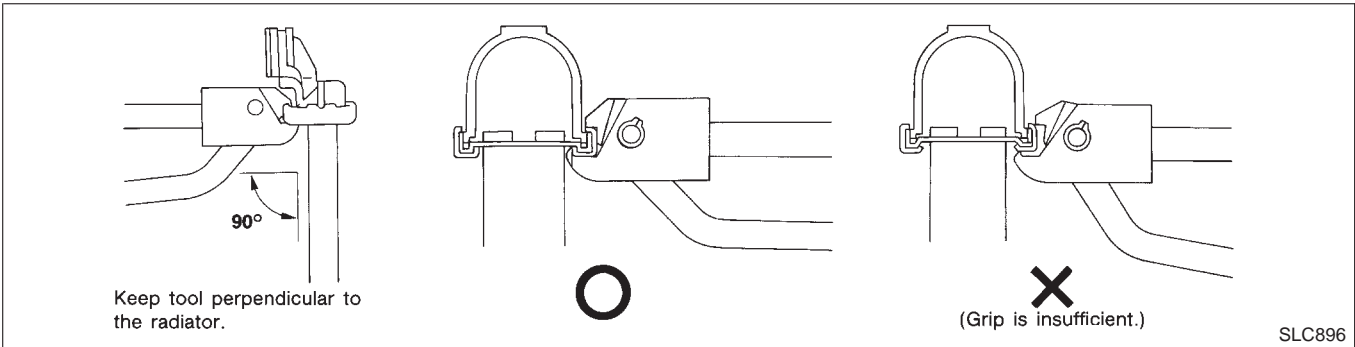

- Use pliers in the locations where Tool cannot be used.

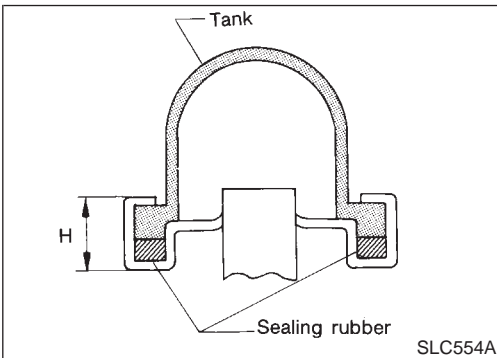

5. Make sure that the rim is completely crimped down.

Standard height "H":
8.0 - 8.4 mm (0.315 - 0.331 in)

6. Confirm that there is no leakage.

Refer to Inspection.

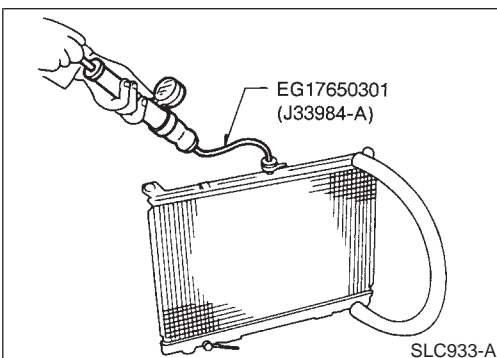

INSPECTION

Apply pressure with Tool.

Specified pressure value:
157 kPa (1.6 kg/cm², 23 psi)

WARNING:

To prevent the risk of the hose coming undone while under pressure, securely fasten it down with a hose clamp. Attach a hose to the oil cooler as well.

GI
 MA
 EM
LC
 EC
 FE
 CL
 MT
 AT
 TF
 PD
 AX
 SU
 BR
 ST
 RS
 BT
 HA
 SC
 EL
 IDX

ENGINE COOLING SYSTEM

Overheating Cause Analysis

Overheating Cause Analysis

NALC0029

| | Symptom | | Check items | |
|----------------------------------|---------------------------------------|--|--|--------------|
| Cooling system parts malfunction | Poor heat transfer | Water pump malfunction | Worn or loose drive belt | — |
| | | Thermostat stuck closed | — | |
| | | Damaged fins | Dust contamination or paper clogging | |
| | | | Mechanical damage | |
| | Clogged radiator cooling tube | Excess foreign material (rust, dirt, sand, etc.) | | |
| | Reduced air flow | Cooling fan does not operate | — | — |
| | | High resistance to fan rotation | | |
| | | Damaged fan blades | | |
| | Damaged radiator shroud | — | — | — |
| | Improper coolant mixture ratio | — | — | — |
| | Poor coolant quality | — | — | — |
| | Insufficient coolant | Coolant leaks | Cooling hose | Loose clamp |
| | | | | Cracked hose |
| | | | Water pump | Poor sealing |
| | | | Radiator cap | Loose |
| Poor sealing | | | | |
| Radiator | | | O-ring for damage, deterioration or improper fitting | |
| | | Cracked radiator tank | | |
| | Cracked radiator core | | | |
| Reservoir tank | Cracked reservoir tank | | | |
| Overflowing reservoir tank | Exhaust gas leaks into cooling system | Cylinder head deterioration | | |
| | | Cylinder head gasket deterioration | | |

ENGINE COOLING SYSTEM

Overheating Cause Analysis (Cont'd)

| | Symptom | | Check items | | | |
|---|--------------------------------|-------------------------|--|---------------------------------------|----|----|
| Except cooling system parts malfunction | — | Overload on engine | Abusive driving | High engine rpm under no load | GI | |
| | | | | Driving in low gear for extended time | MA | |
| | | | | Driving at extremely high speed | EM | |
| | | | Powertrain system malfunction | — | LC | |
| | | | Installed improper size wheels and tires | | EC | |
| | | | Dragging brakes | | FE | |
| | Improper ignition timing | | | | | |
| | Blocked or restricted air flow | Blocked bumper | — | — | CL | |
| | | Blocked radiator grille | Installed car brassiere | | — | MT |
| | | | Mud contamination or paper clogging | | | |
| | | Blocked radiator | — | | AT | |
| | | Blocked condenser | — | | | |
| Installed large fog lamp | | | | | | |

Service Data and Specifications (SDS)

THERMOSTAT

NALC0030

| | |
|---------------------------|--|
| Valve opening temperature | 76.5°C (170°F) |
| Valve lift | More than 8.6 mm/90°C (0.339 in/194°F) |

WATER CONTROL VALVE

NALC0035

| | |
|---------------------------|---|
| Valve opening temperature | 95°C (203°F) |
| Valve lift | More than 8.0 mm/108°C (0.315 in/226°F) |

RADIATOR

NALC0031
Unit: kPa (kg/cm², psi)

| | | |
|-----------------------|----------|------------------------------|
| Cap relief pressure | Standard | 78 - 98 (0.8 - 1.0, 11 - 14) |
| | Limit | 59 (0.6, 9) |
| Leakage test pressure | | 157 (1.6, 23) |

NOTES