

**SECTION CL**

# CONTENTS

|   |    |  |    |
|---|----|--|----|
| <b>PRECAUTIONS</b> .....                    | 2  | Components.....                                    | 10 |
| Precautions .....                           | 2  | Removal.....                                       | 10 |
| <b>PREPARATION</b> .....                    | 3  | Inspection.....                                    | 11 |
| Special Service Tools .....                 | 3  | Installation.....                                  | 11 |
| Commercial Service Tools .....              | 3  | Lubrication .....                                  | 11 |
| <b>NOISE, VIBRATION AND HARSHNESS (NVH)</b> |    | <b>CLUTCH DISC, CLUTCH COVER AND</b>               |    |
| <b>TROUBLESHOOTING</b> .....                | 4  | <b>FLYWHEEL</b> .....                              | 12 |
| NVH Troubleshooting Chart.....              | 4  | Components.....                                    | 12 |
| CLUTCH .....                                | 4  | Removal.....                                       | 12 |
| <b>CLUTCH SYSTEM - HYDRAULIC TYPE</b> ..... | 5  | Inspection and Adjustment .....                    | 12 |
| Components.....                             | 5  | CLUTCH DISC.....                                   | 12 |
| On-Vehicle Inspection and Adjustment.....   | 6  | CLUTCH COVER .....                                 | 13 |
| ADJUSTING CLUTCH PEDAL .....                | 6  | FLYWHEEL INSPECTION .....                          | 13 |
| Air Bleeding Procedure.....                 | 7  | Installation.....                                  | 13 |
| <b>CLUTCH MASTER CYLINDER</b> .....         | 8  | <b>SERVICE DATA AND SPECIFICATIONS (SDS)</b> ..... | 15 |
| Components.....                             | 8  | Clutch Control System.....                         | 15 |
| Disassembly and Assembly.....               | 8  | Clutch Master Cylinder (With damper) .....         | 15 |
| Inspection.....                             | 8  | Clutch Operating Cylinder .....                    | 15 |
| <b>OPERATING CYLINDER</b> .....             | 9  | Clutch Disc.....                                   | 15 |
| Components.....                             | 9  | Clutch Cover .....                                 | 15 |
| Inspection.....                             | 9  | Clutch Pedal .....                                 | 15 |
| <b>CLUTCH RELEASE MECHANISM</b> .....       | 10 |  |    |

# PRECAUTIONS

## Precautions

NACL0001

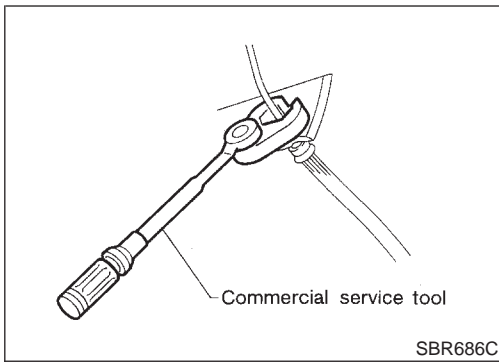

## Precautions

- Recommended fluid is brake fluid “DOT 3”.
- Never reuse drained brake fluid.
- Be careful not to splash brake fluid on painted areas.
- When removing and installing clutch piping, use Tool.
- Use new brake fluid to clean or wash all parts of master cylinder, operating cylinder and clutch damper.
- Never use mineral oils such as gasoline or kerosene. It will ruin the rubber parts of the hydraulic system.

### **WARNING:**

After cleaning the clutch disc, wipe it with a dust collector. Do not use compressed air.

# PREPARATION

Special Service Tools

## Special Service Tools

NACL0002

The actual shapes of Kent-Moore tools may differ from those of special service tools illustrated here.

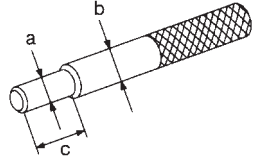
| Tool number<br>(Kent-Moore No.)<br>Tool name | Description  |
|--|--|
| ST20670000<br>( — )<br>Clutch aligning bar   |  <p>Installing clutch cover and clutch disc<br/> <b>a: 15 mm (0.59 in) dia.</b><br/> <b>b: 23 mm (0.91 in) dia.</b><br/> <b>c: 30 mm (1.18 in)</b></p> <p>NT405</p> |

GI

MA

EM

LC

EC

FE

**CL**

MT

AT

## Commercial Service Tools

NACL0003

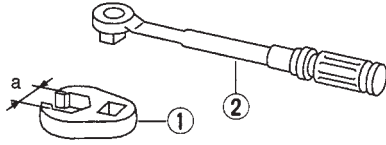
| Tool name                               | Description  |
|---|--|
| 1 Flare nut crowfoot<br>2 Torque wrench |  <p>Removing and installing clutch piping<br/> <b>a: 10 mm (0.39 in)</b></p> <p>NT360</p> |

TF

PD

AX

SU

BR

ST

RS

BT

HA

SC

EL

IDX

# NOISE, VIBRATION AND HARSHNESS (NVH) TROUBLESHOOTING

## NVH Troubleshooting Chart

### NVH Troubleshooting Chart

Use the chart below to help you find the cause of the problem. The numbers indicate the priority of the likely cause of the problem. Check each part in order. If necessary, repair or replace these parts.

NACL0027S01

## CLUTCH

NACL0027S01/01

| Reference page                      | CL-6                                       | CL-7 | CL-8 | CL-9 | Refer to EM-60, "REMOVAL". | CL-10 | CL-12 | CL-12 | CL-12 | CL-12 | CL-12 | CL-12 | CL-12 | CL-12 | CL-12 | CL-12 | CL-13 | CL-13 | CL-13 | CL-13 |   |
|-------------------------------------|--|------|------|------|----------------------------|-------|-------|-------|-------|-------|-------|-------|-------|-------|-------|-------|-------|-------|-------|-------|---|
| SUSPECTED PARTS<br>(Possible cause) | CLUTCH PEDAL (Free play out of adjustment) |      |      |      |                            |       |       |       |       |       |       |       |       |       |       |       |       |       |       |       |   |
|                                     | CLUTCH LINE (Air in line)                  |      | 1    |      |                            |       |       |       |       |       |       |       |       |       |       |       |       |       |       |       |   |
|                                     | MASTER CYLINDER PISTON CUP (Damaged)       |      |      | 2    |                            |       |       |       |       |       |       |       |       |       |       |       |       |       |       |       |   |
|                                     | OPERATING CYLINDER PISTON CUP (Damaged)    |      |      |      | 2                          |       |       |       |       |       |       |       |       |       |       |       |       |       |       |       |   |
|                                     | ENGINE MOUNTING (Loose)                    |      |      |      |                            | 1     |       |       |       |       |       |       |       |       |       |       |       |       |       |       |   |
|                                     | RELEASE BEARING (Worn, dirty or damaged)   |      |      |      |                            |       | 1     |       |       |       |       |       |       |       |       |       |       |       |       |       |   |
|                                     | CLUTCH DISC (Out of true)                  |      |      |      |                            |       |       |       |       |       |       |       |       |       |       |       |       |       |       |       |   |
|                                     | CLUTCH DISC (Runout is excessive)          |      |      |      |                            |       |       |       | 2     |       |       |       |       |       |       |       |       |       |       |       |   |
|                                     | CLUTCH DISC (Lining broken)                |      |      |      |                            |       |       |       |       |       |       |       |       |       |       |       |       |       |       |       |   |
|                                     | CLUTCH DISC (Dirty or burned)              |      |      |      |                            |       |       |       |       |       |       |       |       |       |       |       |       |       |       |       |   |
|                                     | CLUTCH DISC (Oily)                         |      |      |      |                            |       |       |       |       |       |       |       |       |       | 2     |       |       |       |       |       |   |
|                                     | CLUTCH DISC (Worn out)                     |      |      |      |                            |       |       |       |       |       |       |       |       |       |       |       |       |       |       |       |   |
|                                     | CLUTCH DISC (Hardened)                     |      |      |      |                            |       |       |       |       |       |       |       |       |       |       |       |       |       |       |       |   |
|                                     | CLUTCH DISC (Lack of spline grease)        |      |      |      |                            |       |       |       |       |       |       |       |       |       |       |       |       |       |       |       |   |
|                                     | DIAPHRAGM SPRING (Damaged)                 |      |      |      |                            |       |       |       |       |       |       |       |       |       |       |       |       |       |       |       | 3 |
|                                     | PRESSURE PLATE (Distortion)                |      |      |      |                            |       |       |       |       |       |       |       |       |       |       |       |       |       |       |       |   |
| FLYWHEEL (Distortion)               |  |      |      |      |                            |       |       |       |       |       |       |       |       |       |       |       |       |       |       |       | 5 |
| Symptom                             | Clutch grabs/chatters                      |      |      |      |                            |       |       |       |       |       |       |       |       |       |       |       |       |       |       |       |   |
|                                     | Clutch pedal spongy                        |      |      |      |                            |       |       |       |       |       |       |       |       |       |       |       |       |       |       |       |   |
|                                     | Clutch noisy                               |      |      |      |                            |       |       |       |       |       |       |       |       |       |       |       |       |       |       |       |   |
|                                     | Clutch slips                               |      |      |      |                            |       |       |       |       |       |       |       |       |       |       |       |       |       |       |       |   |
| Clutch does not disengage           |  |      |      |      |                            |       |       |       |       |       |       |       |       |       |       |       |       |       |       |       |   |

# CLUTCH SYSTEM — HYDRAULIC TYPE

Components

## Components

NACL0004

SEC. 300-305-306-465

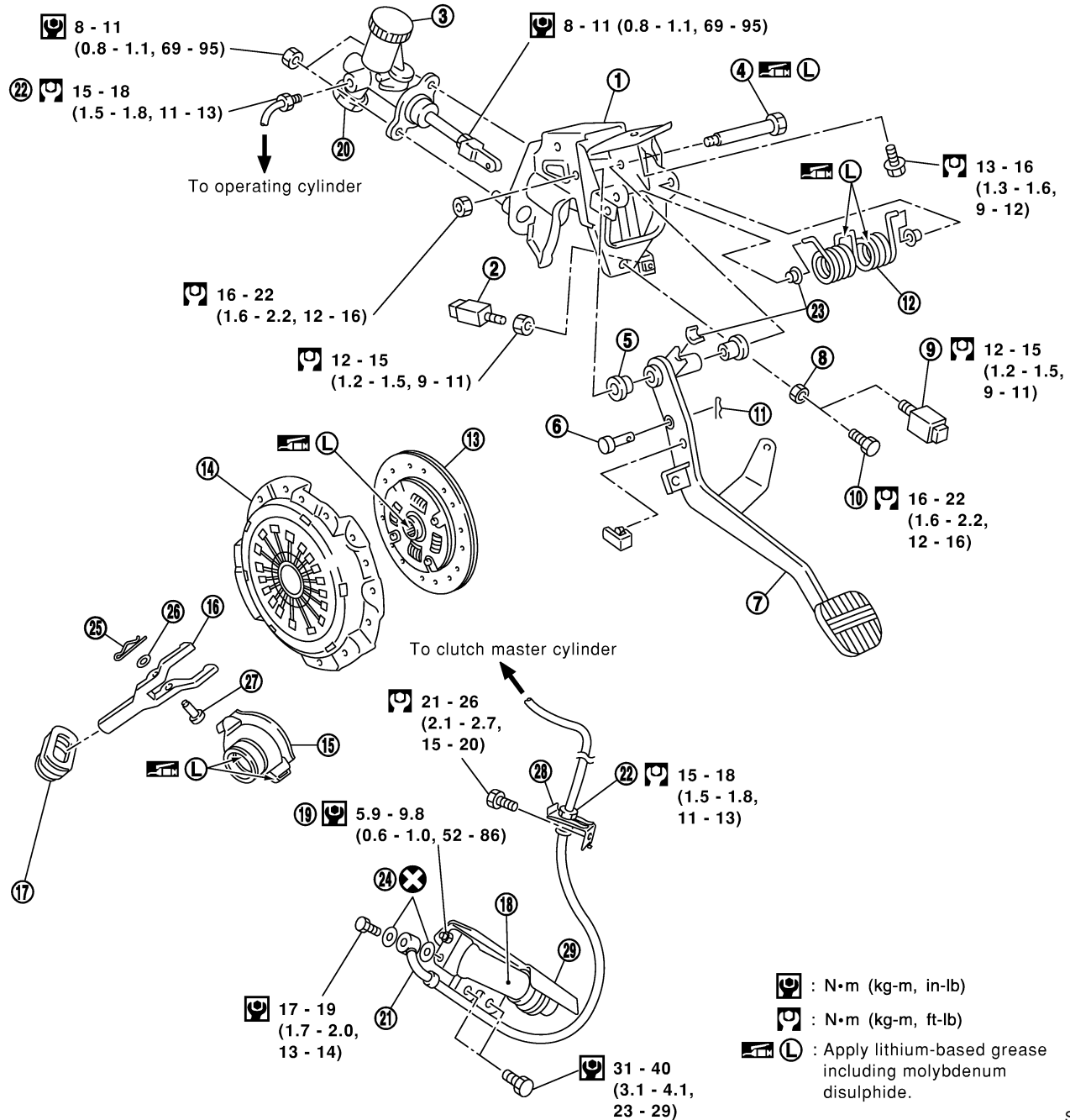

SCL910

- |                            |                                     |                            |
|----------------------------|-------------------------------------|----------------------------|
| 1. Clutch pedal bracket    | 11. Snap pin                        | 21. Clutch hose            |
| 2. Clutch interlock switch | 12. Assist spring                   | 22. Flare nut              |
| 3. Clutch master cylinder  | 13. Clutch disc                     | 23. Bushing                |
| 4. Fulcrum pin             | 14. Clutch cover                    | 24. Copper washer          |
| 5. Bushing                 | 15. Release bearing                 | 25. Snap pin               |
| 6. Clevis pin              | 16. Withdrawal lever                | 26. Washer                 |
| 7. Clutch pedal            | 17. Dust boot                       | 27. Withdrawal lever shaft |
| 8. Lock nut                | 18. Operating cylinder              | 28. Lock spring            |
| 9. ASCD cancel switch      | 19. Air bleeder                     | 29. Heat insulator         |
| 10. Pedal stopper bolt     | 20. Clutch damper (not serviceable) |                            |

GI  
MA  
EM  
LC  
EC  
FE  
CL  
MT  
AT  
TF  
PD  
AX  
SU  
BR  
ST  
RS  
BT  
HA  
SC  
EL  
IDX

# CLUTCH SYSTEM — HYDRAULIC TYPE

On-Vehicle Inspection and Adjustment

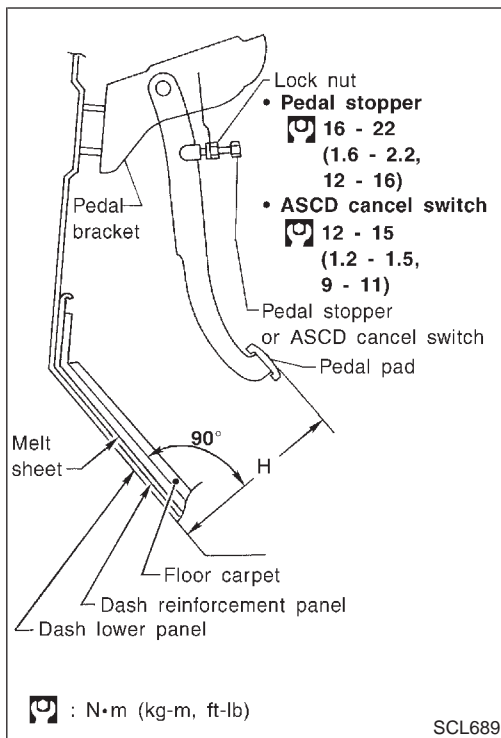

## On-Vehicle Inspection and Adjustment

NACL0036

### ADJUSTING CLUTCH PEDAL

NACL0036S01

1. Adjust pedal height with pedal stopper or ASCD cancel switch.

**Pedal height "H":**

**176 - 186 mm (6.93 - 7.32 in)**

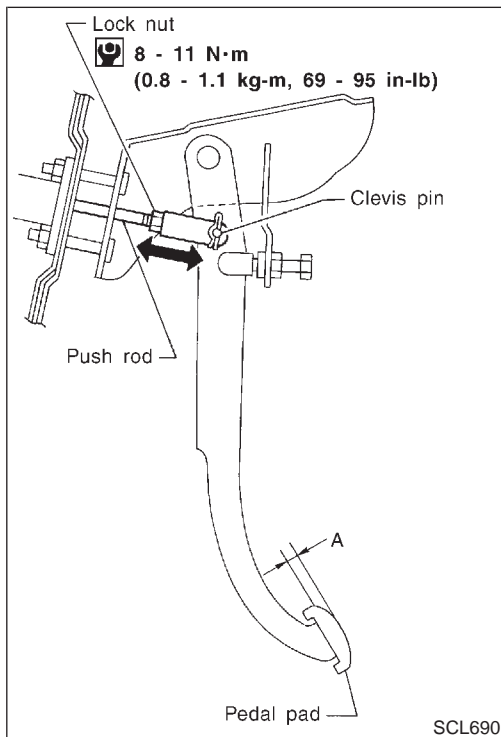

2. Adjust pedal free play with master cylinder push rod. Then tighten lock nut.

**Pedal free play (measured at pedal pad) "A":**

**9 - 16 mm (0.35 - 0.63 in)**

**Pedal free play means the following total measured at position of pedal pad:**

- Play due to clevis pin and clevis pin hole in clutch pedal.
3. Make sure that clevis pin can rotate smoothly. If not, readjust pedal free play with master cylinder push rod.

# CLUTCH SYSTEM — HYDRAULIC TYPE

On-Vehicle Inspection and Adjustment (Cont'd)

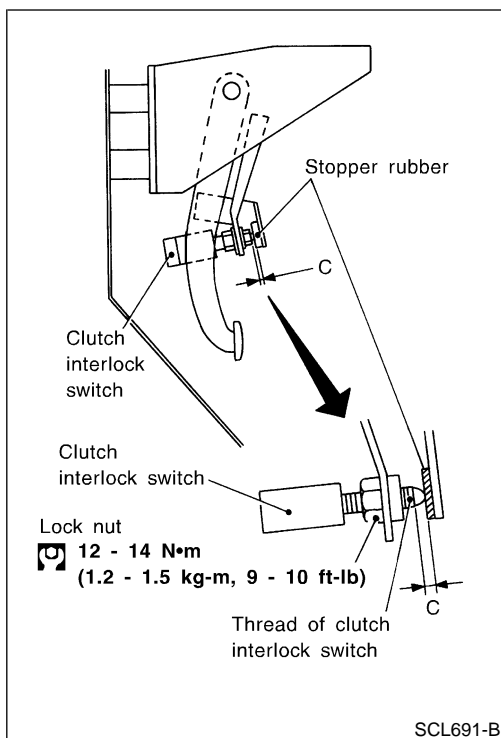

## — Models with Clutch Interlock System —

- Adjust clearance "C" shown in the figure while fully depressing clutch pedal.

**Clearance C:**

**0.3 - 1.0 mm (0.012 - 0.039 in)**

NACL0036S0101

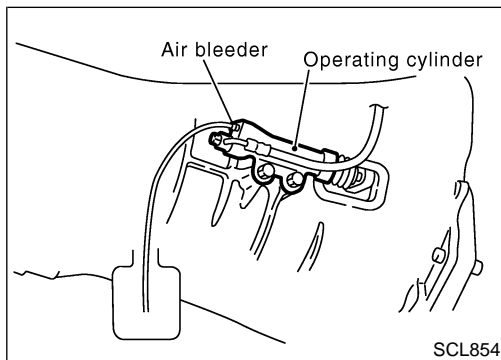

## Air Bleeding Procedure

### CAUTION:

- Check the clutch fluid level of the reservoir for shortage.
- Keep clutch fluid away from the coating surface of the body or other parts. If it adheres, remove it quickly and flush the area with water.

- Fill up master cylinder reservoir tank with new clutch fluid.
- Connect a clear vinyl hose to air bleeder.
- Carefully depress clutch pedal fully and release it. Repeat the cycle several times at an interval of 2 or 3 seconds.
- While depressing clutch pedal, open air bleeder.
- Close air bleeder.
- Release clutch pedal, and wait for approx. 5 seconds.
- Repeat steps 3 to 6 until no air is found in clutch fluid.

NACL0037

GI  
MA  
EM  
LC  
EC  
FE  
CL  
MT  
AT  
TF  
PD  
AX  
SU  
BR  
ST  
RS  
BT  
HA  
SC  
EL  
IDX

# CLUTCH MASTER CYLINDER

Components

## Components

NACL0006

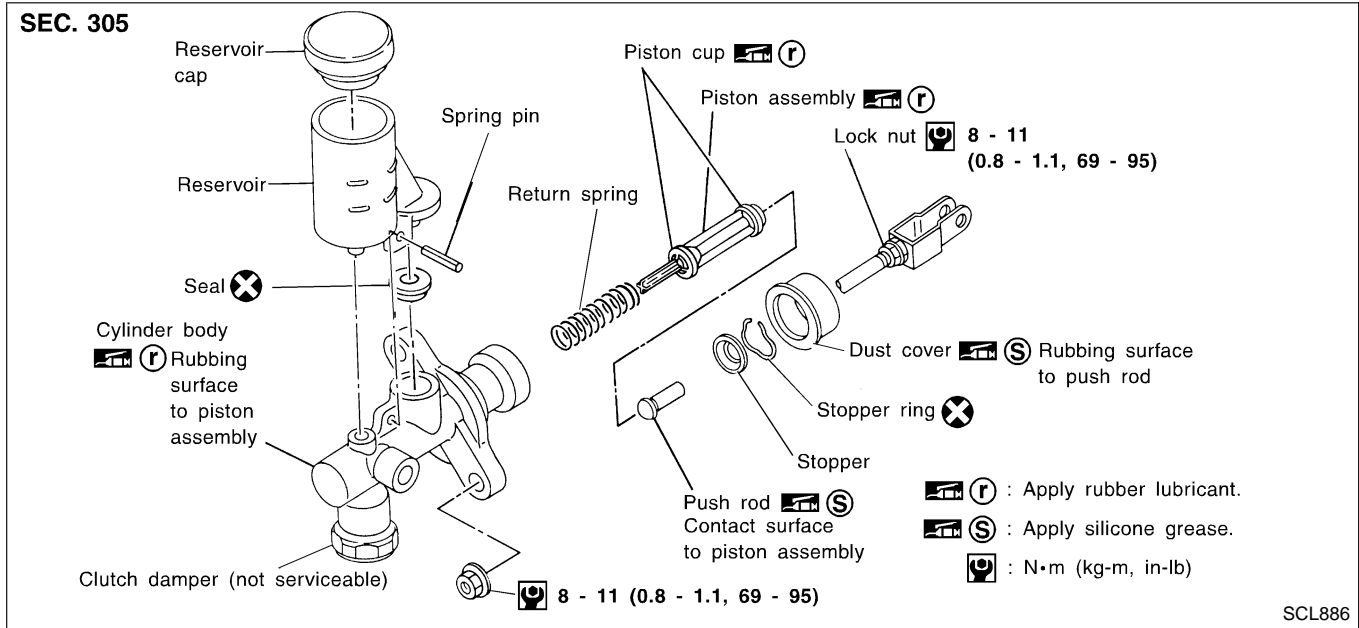

## Disassembly and Assembly

NACL0007

- When removing and installing stopper ring, pry it off with screwdriver while pushing push rod into cylinder.

## Inspection

NACL0008

Check the following items, and replace if necessary.

- Rubbing surface of cylinder and piston, for uneven wear, rust or damage
- Piston with piston cup, for wear or damage
- Return spring, for wear or damage
- Dust cover, for cracks, deformation or damage
- Reservoir, for deformation or damage



## Components

NACL0009

SEC. 306

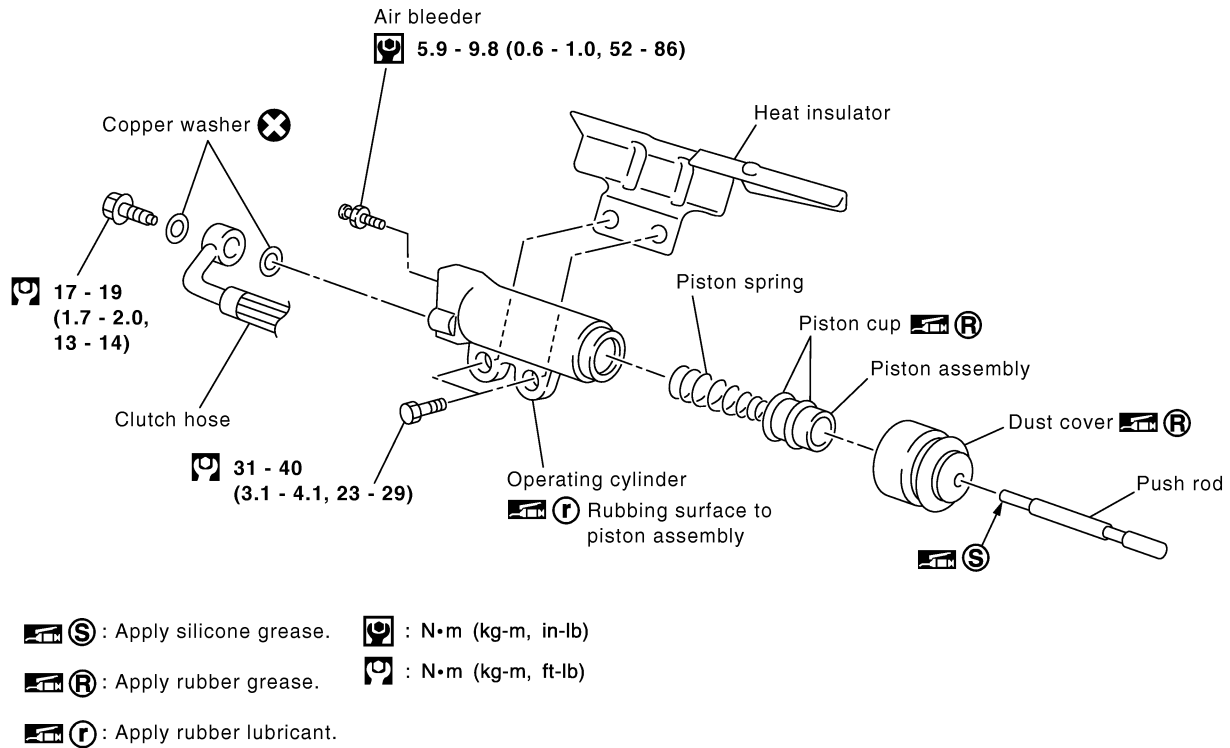

SCL855-B

## Inspection

NACL0010

Check the following items, and replace if necessary.

- Rubbing surface of cylinder and piston, for uneven wear, rust or damage
- Piston with piston cup, for wear or damage
- Piston spring, for wear or damage
- Dust cover, for cracks, deformation or damage

GI  
MA  
EM  
LC  
EC  
FE  
CL  
MT  
AT  
TF  
PD  
AX  
SU  
BR  
ST  
RS  
BT  
HA  
SC  
EL  
IDX

# CLUTCH RELEASE MECHANISM

Components

## Components

NACL0013

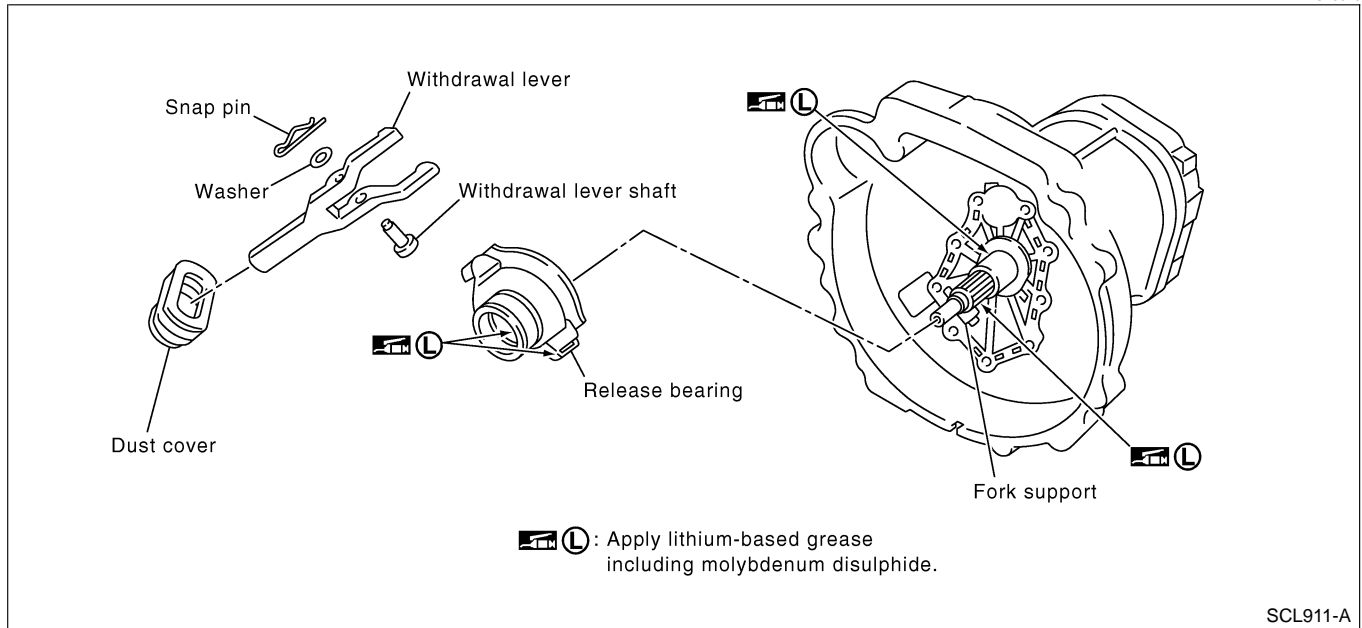

SCL911-A

**CAUTION:**  
Keep the clutch disc facing, pressure plate and flywheel free of oil and grease.

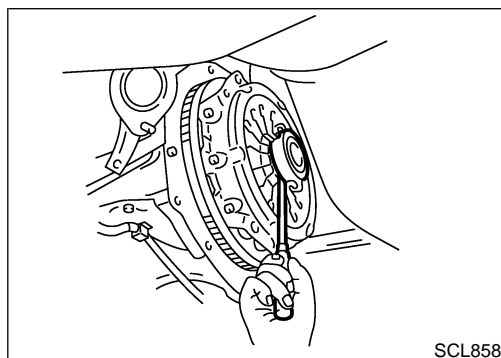
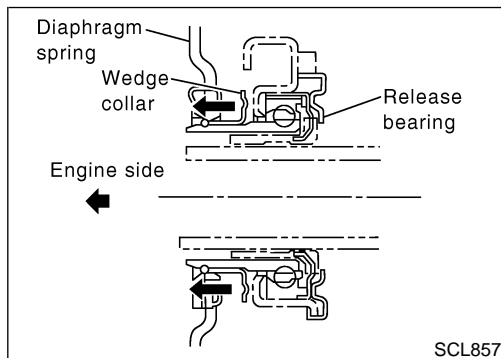

## Removal

NACL0029

1. Remove manual transmission from the vehicle. Refer to MT-7, "Removal and Installation".
2. Remove withdrawal lever from inside clutch housing.
3. Press wedge collar on clutch cover toward the engine.
4. Using a flat-head screwdriver or the like, remove release bearing from clutch cover.

# CLUTCH RELEASE MECHANISM

Inspection

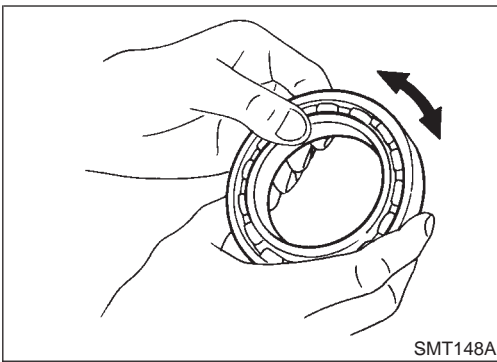

## Inspection

NACL0030

Check the following items, and replace the part, if necessary.

- Release bearing seizure, damages, and rough rotation.
- Abnormal wear on contact surfaces of release bearing or withdrawal lever.
- Dust cover cracks.

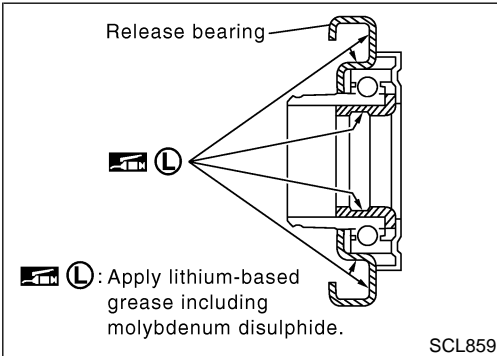

## Installation

NACL0031

1. Apply clutch sleeve grease to the areas shown by the arrows in the figure.
2. Install the release bearing to main drive shaft.
3. Install withdrawal lever to fork support, and secure it with withdrawal lever shaft, washer, and snap pin.
4. Operate withdrawal lever to check sliding parts for smooth movement.

### CAUTION:

**Remove excessive grease coming-out.**

5. Install manual transmission.  
Refer to MT-7, "Removal and Installation".

## Lubrication

NACL0016

- Apply recommended grease to contact surface and rubbing surface.
- **Too much lubricant might damage clutch disc facing.**

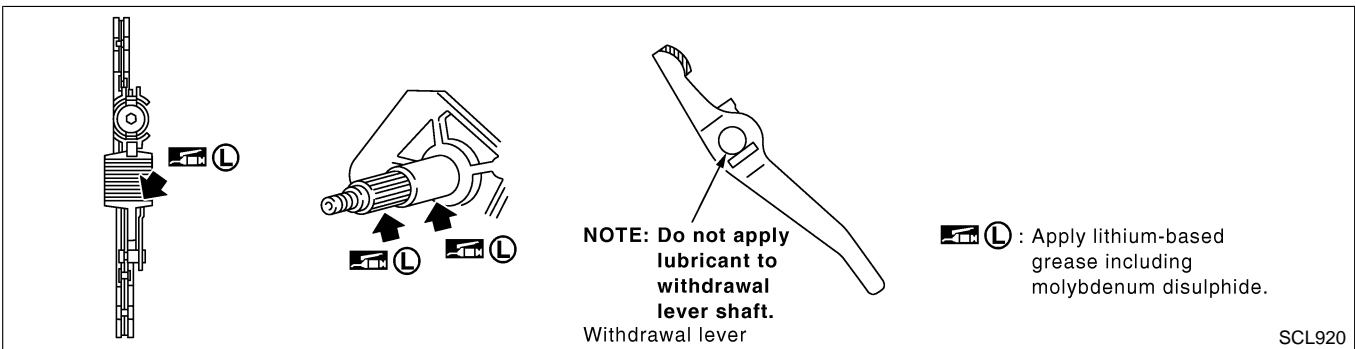

GI  
MA  
EM  
LC  
EC  
FE  
CL  
MT  
AT  
TF  
PD  
AX  
SU  
BR  
ST  
RS  
BT  
HA  
SC  
EL  
IDX

# CLUTCH DISC, CLUTCH COVER AND FLYWHEEL

## Components

NACL0032

**SEC. 300**

**Clutch disc**

- Do not clean in solvent.
- When installing, be careful that grease applied to main drive shaft does not adhere to clutch disc.

**Washer**

**Clutch cover securing bolt**

**Clutch cover**

**Flywheel**

**First step: 10 - 19**  
(1.0 - 2.0, 8 - 14)

**Final step: 35 - 44**  
(3.5 - 4.5, 26 - 32)

**L** : Apply lithium-based grease including molybdenum disulphide.

**N** : N•m (kg-m, ft-lb)

SCL861

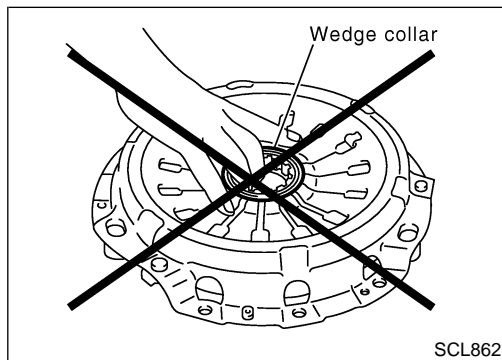

## Removal

NACL0033

1. Remove manual transmission from the vehicle. Refer to MT-7, "Removal and Installation".
2. Remove release bearing from clutch cover.
3. Loosen mounting bolts on the clutch cover evenly, and remove clutch cover and clutch disc.

### CAUTION:

Do not hold the wedge collar when handling the clutch cover.

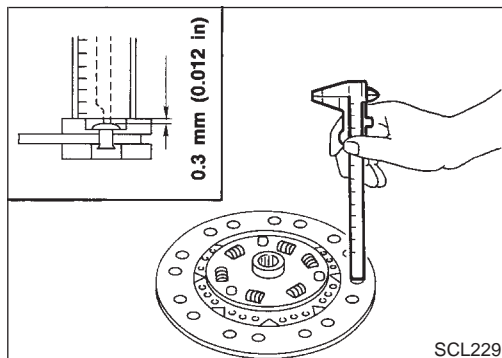

## Inspection and Adjustment

NACL0019

### CLUTCH DISC

NACL0019S01

Check the following items, and replace if necessary.

- Clutch disc, for burns, discoloration, oil or grease leakage
- Clutch disc, for wear of facing

**Wear limit of facing surface to rivet head:**  
**0.3 mm (0.012 in)**

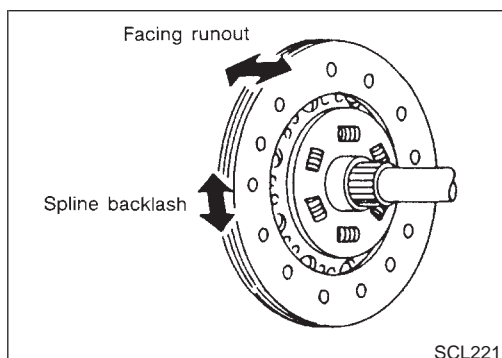

- Clutch disc, for backlash of spline and runout of facing
- Maximum backlash of spline (at outer edge of disc):**  
**1.0 mm (0.039 in)**
- Runout limit:**  
**Less than 0.7 mm (0.028 in)**
- Distance of runout check point (from hub center):**  
**120 mm (4.72 in)**

# CLUTCH DISC, CLUTCH COVER AND FLYWHEEL

Inspection and Adjustment (Cont'd)

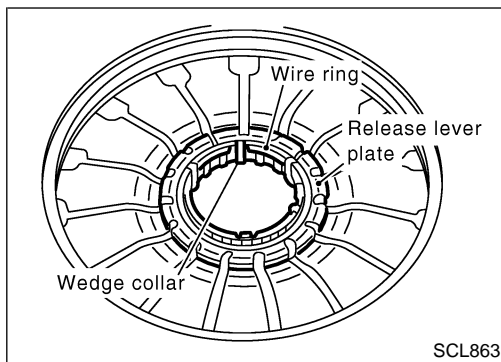

## CLUTCH COVER

NACL0019S04

- Check parts (wedge collar and wiring) contacting the release bearing. If any worn or damaged parts are found, replace the clutch cover as an assembly.
- Check release lever plate for looseness. If necessary, replace clutch cover as an assembly.
- Check thrust ring of the clutch cover for wear or bending. If necessary, replace clutch cover as an assembly.
- If seizure mark or discoloration is found with the mating surfaces between pressure plate and clutch disc of clutch cover, repair them with sand-paper. If surfaces are distorted or damaged, replace clutch cover as an assembly.

## REFERENCE:

- If thrust ring is worn, chattering noise is heard when the riveted area is lightly hit with a hammer.
- If thrust ring is bent, jangling noise is heard when cover is swung up and down.

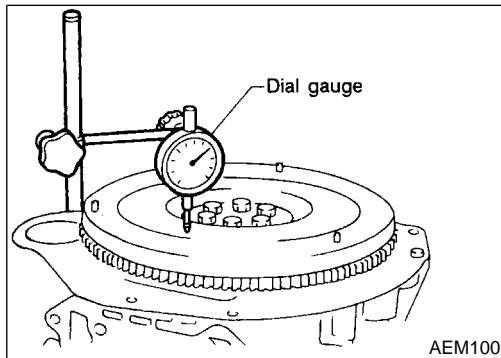

## FLYWHEEL INSPECTION

NACL0019S03

### CAUTION:

Do not allow any magnetic materials to contact the ring gear teeth.

- Inspect contact surface of flywheel for slight burns or discoloration. Clean flywheel with emery paper.
- Check flywheel runout.

**Maximum allowable runout:**

**Refer to EM-73, "Flywheel/Drive plate Runout".**

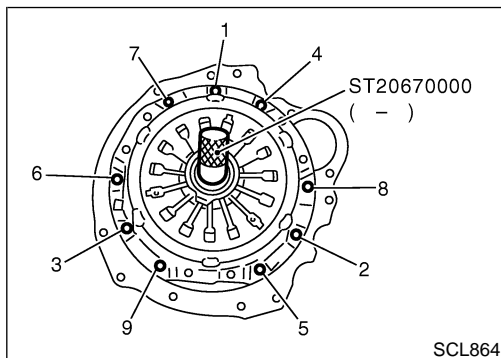

## Installation

NACL0035

1. Apply specified Nissan clutch grease to clutch disc and spline of main drive shaft.

### CAUTION:

Always apply grease. If no grease is applied, it may cause abnormal noise, insufficient disengagement, or damage to the clutch. Also, always remove excessive grease. If grease is applied excessively, it may cause sliding or juddering.

2. Install clutch disc and clutch cover. Tighten mounting bolts temporarily, and install clutch aligning bar (SST).
3. Tighten clutch cover mounting bolts evenly in the order shown in the figure by two steps.

**1st step:**

**🔩 : 10 - 19 N·m (1.0 - 2.0 kg·m, 8 - 14 ft·lb)**

**Final step:**

**🔩 : 35 - 44 N·m (3.5 - 4.5 kg·m, 26 - 32 ft·lb)**

GI  
MA  
EM  
LC  
EC  
FE  
CL  
MT  
AT  
TF  
PD  
AX  
SU  
BR  
ST  
RS  
BT  
HA  
SC  
EL  
IDX

# CLUTCH DISC, CLUTCH COVER AND FLYWHEEL

Installation (Cont'd)

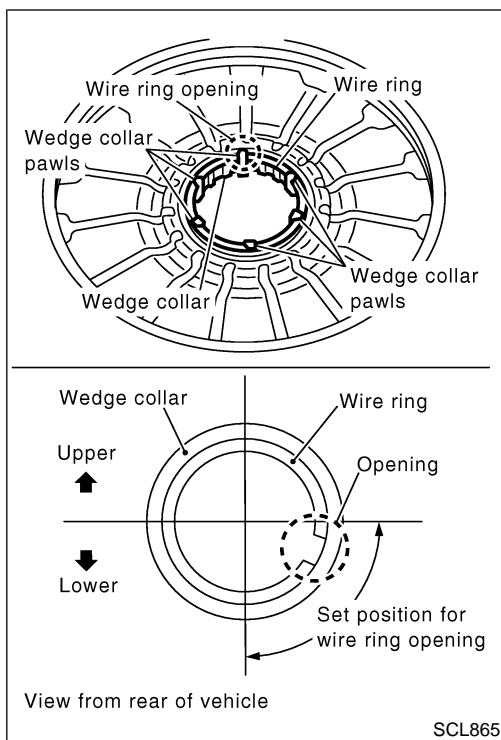

4. Check that the wire ring of clutch cover is installed securely to wedge collar pawls.
5. Turn flywheel so that the wire ring opening is positioned as shown in the figure.

**CAUTION:**

**Always perform alignment of the wire ring opening. If transmission is installed without alignment, it may cause clutch disengagement failure or clutch pedal operation failure.**

6. Install manual transmission.  
Refer to MT-7, "Removal and Installation".

# SERVICE DATA AND SPECIFICATIONS (SDS)

Clutch Control System

## Clutch Control System

NACL0028

|                        |           |
|------------------------|-----------|
| Type of clutch control | Hydraulic |
|------------------------|-----------|

## Clutch Master Cylinder (With damper)

NACL0021

|                |                   |
|----------------|-------------------|
| Inner diameter | 15.87 mm (5/8 in) |
|----------------|-------------------|

## Clutch Operating Cylinder

NACL0022

|                |                   |
|----------------|-------------------|
| Inner diameter | 19.05 mm (3/4 in) |
|----------------|-------------------|

## Clutch Disc

NACL0023  
Unit: mm (in)

|  |  |
|--|--|
| Model  | 250  |
| Facing size<br>(Outer dia. x inner dia. x thickness) | 250 × 160 × 3.5<br>(9.84 × 6.30 × 0.138)                     |
| Thickness of disc assembly With load                 | 7.9 - 8.3 (0.311 - 0.327)<br>with 7,355 N (750 kg, 1,654 lb) |
| Wear limit of facing surface to rivet head           | 0.3 (0.012)  |
| Runout limit of facing                               | 0.7 (0.028)  |
| Distance of runout check point (from hub center)     | 120 (4.72)   |
| Maximum backlash of spline (at outer edge of disc)   | 1.0 (0.039)  |

## Clutch Cover

NACL0024  
Unit: mm (in)

|   |                             |
|---|-----------------------------|
| Model                                       | 250                         |
| Set-load                                    | 7,355 N (750 kg, 1,654 lb)  |
| Diaphragm spring height                     | 48.2 - 50.2 (1.898 - 1.976) |
| Uneven limit of diaphragm spring toe height | 0.6 (0.024)                 |

## Clutch Pedal

NACL0025  
Unit: mm (in)

|  |                           |
|--|---------------------------|
| Pedal height "H"   | 176 - 186 (6.93 - 7.32)   |
| Pedal free play (at pedal pad)   | 9 - 16 (0.35 - 0.63)      |
| Clearance between pedal stopper rubber and threaded end of ASCD switch   | 0.3 - 1.0 (0.012 - 0.039) |
| Clearance between pedal stopper rubber and threaded end of clutch interlock switch (when depressing clutch pedal fully.) | 0.3 - 1.0 (0.012 - 0.039) |

\*: Measured from surface of dash lower panel to pedal pad.

GI  
MA  
EM  
LC  
EC  
FE  
CL  
MT  
AT  
TF  
PD  
AX  
SU  
BR  
ST  
RS  
BT  
HA  
SC  
EL  
IDX

## NOTES