

SECTION **PR**  
PROPELLER SHAFT

A  
B  
C

PR

CONTENTS

E

<b>PREPARATION</b> .....	2	<b>REAR PROPELLER SHAFT</b> .....	9	F
Commercial Service Tools .....	2	On-Vehicle Service .....	9	
<b>NOISE, VIBRATION, AND HARSHNESS (NVH)</b>		APPEARANCE AND NOISE INSPECTION .....	9	
<b>TROUBLESHOOTING</b> .....	3	PROPELLER SHAFT VIBRATION .....	9	G
NVH Troubleshooting Chart .....	3	Removal and Installation .....	10	
<b>FRONT PROPELLER SHAFT</b> .....	4	COMPONENTS .....	10	
On-Vehicle Service .....	4	REMOVAL .....	10	H
APPEARANCE AND NOISE INSPECTION .....	4	INSPECTION .....	11	
PROPELLER SHAFT VIBRATION .....	4	INSTALLATION .....	11	
Removal and Installation .....	5	Disassembly and Assembly .....	12	
COMPONENTS .....	5	DISASSEMBLY .....	12	I
REMOVAL .....	5	ASSEMBLY .....	13	
INSPECTION .....	6	<b>SERVICE DATA AND SPECIFICATIONS (SDS)</b> .....	14	J
INSTALLATION .....	6	General Specifications .....	14	
Disassembly and Assembly .....	6	Snap Ring .....	15	
DISASSEMBLY .....	6			K
ASSEMBLY .....	7			L

M

# PREPARATION

## PREPARATION

PF0:00002

### Commercial Service Tools

EDS001GW

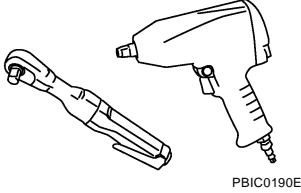
Tool name	Description
<p data-bbox="152 296 261 323">Power tool</p>  <p data-bbox="862 516 933 533">PBIC0190E</p>	<p data-bbox="1008 296 1260 323">Loosening bolts and nuts</p>

# NOISE, VIBRATION, AND HARSHNESS (NVH) TROUBLESHOOTING

## NOISE, VIBRATION, AND HARSHNESS (NVH) TROUBLESHOOTING

PF0:0003

### NVH Troubleshooting Chart

EDS001GX

Use the chart below to help you find the cause of the symptom. If necessary, repair or replace these parts.

Reference page		<a href="#">PR-4 (front)</a> <a href="#">PR-9 (rear)</a>	<a href="#">PR-4 (front)</a> <a href="#">PR-9 (rear)</a>	<a href="#">PR-4 (front)</a> <a href="#">PR-9 (rear)</a>	<a href="#">RFD-7, "NVH Troubleshooting Chart"</a>	<a href="#">FAX-4, "NVH Troubleshooting Chart"</a> <a href="#">RAX-4, "NVH Troubleshooting Chart"</a>	<a href="#">FSU-4, "NVH Troubleshooting Chart"</a> <a href="#">RSU-4, "NVH Troubleshooting Chart"</a>	<a href="#">WT-3, "NVH Troubleshooting Chart"</a>	<a href="#">WT-3, "NVH Troubleshooting Chart"</a>	<a href="#">RAX-4, "NVH Troubleshooting Chart"</a>	<a href="#">BR-5, "NVH Troubleshooting Chart"</a>	<a href="#">PS-5, "NVH Troubleshooting Chart"</a>
Possible cause and suspected parts		Uneven rotation torque	Rotation imbalance	Excessive run out	Differential	Axle	Suspension	Tires	Road wheel	Drive shaft	Brakes	Steering
Symptom	Noise	x	x	x	x	x	x	x	x	x	x	x
	Shake					x	x	x	x	x	x	x
	Vibration	x	x	x		x	x	x		x		x

x: Applicable

A  
B  
C  
PR  
E  
F  
G  
H  
I  
J  
K  
L  
M

# FRONT PROPELLER SHAFT

## FRONT PROPELLER SHAFT

PF3:37200

### On-Vehicle Service

EDS001GY

#### APPEARANCE AND NOISE INSPECTION

- Check the propeller shaft tube surface for dents or cracks. If damaged, replace the propeller shaft assembly.
- Check the bearings for noise and damage. Repair or replace the bearings as necessary.

#### PROPELLER SHAFT VIBRATION

If a vibration is present at high speed, inspect the propeller shaft runout first.

1. Measure the runout of the propeller shaft tube at several points by rotating the final drive companion flange with your hands.

**Propeller shaft runout limit : 0.6 mm (0.024 in) or less**

2. If the runout exceeds specifications, disconnect the propeller shaft at the final drive companion flange; then rotate the companion flange 90°, 180° and 270° and reconnect the propeller shaft.
3. Check the runout again. If the runout still exceeds specifications, replace the propeller shaft assembly.
4. After installation, check for vibration by driving the vehicle.

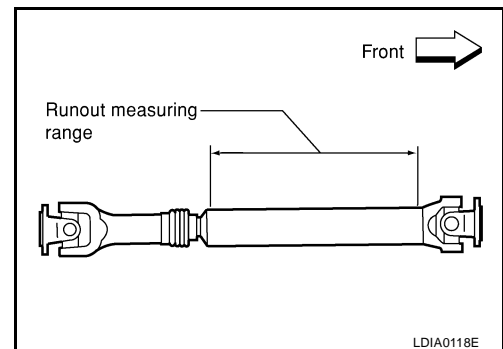
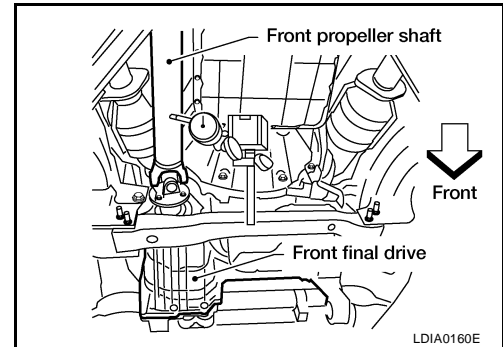

# FRONT PROPELLER SHAFT

EDS001GZ

## Removal and Installation COMPONENTS

### Model 2F1310

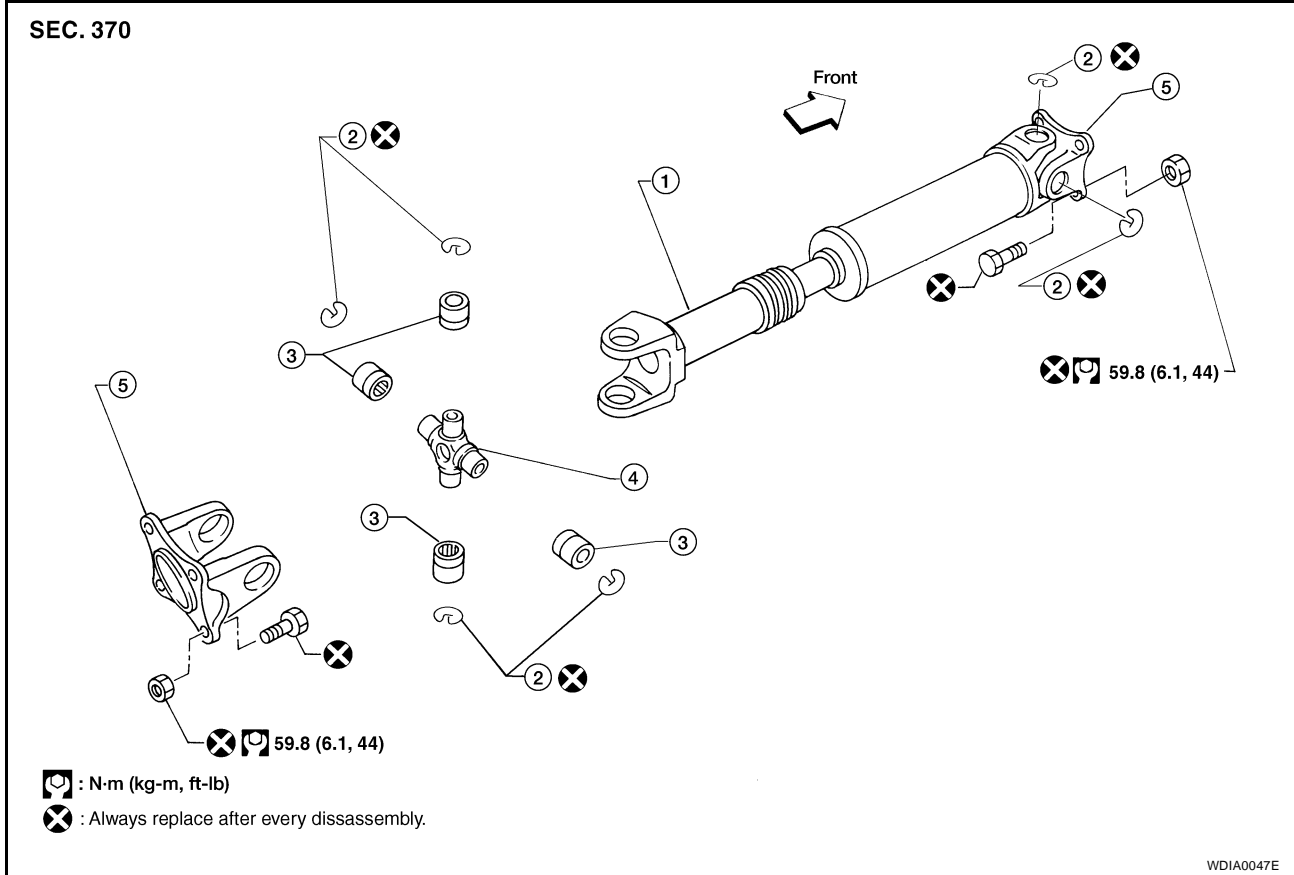

- |                         |                |                    |
|-------------------------|----------------|--------------------|
| 1. Propeller shaft tube | 2. Snap ring   | 3. Journal bearing |
| 4. Journal              | 5. Flange yoke |                    |

## REMOVAL

- Put matching marks on the front propeller shaft flange yoke and the front final drive companion flange as shown.

### CAUTION:

**For matching marks, use paint. Never damage the flange yoke and companion flange of the front final drive.**

- Put matching marks on the front propeller shaft flange yoke and the transfer companion flange.

### CAUTION:

**For matching marks, use paint. Never damage the flange yoke and companion flange of the front final drive.**

- Remove the bolts and then remove the front propeller shaft from the front final drive and transfer.

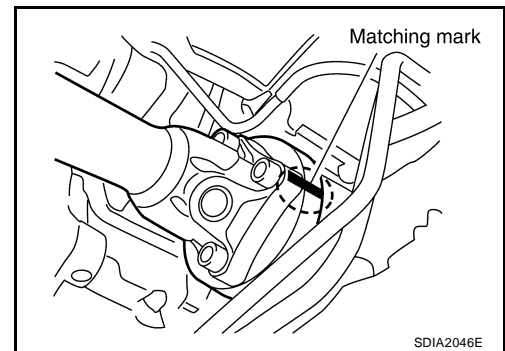

# FRONT PROPELLER SHAFT

## INSPECTION

- Inspect the propeller shaft runout. If runout exceeds the limit, replace the propeller shaft assembly.

**Runout limit : 0.6 mm (0.024 in) or less**

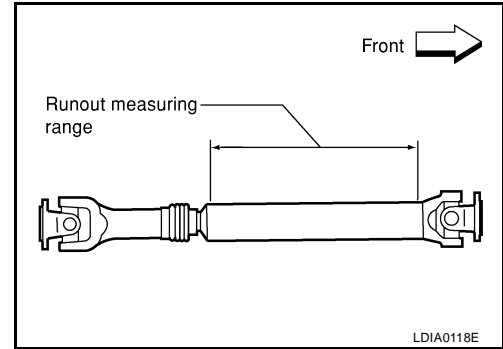

- While holding the flange yoke on one side, check axial play of the joint as shown. If the journal axial play exceeds the specification, repair or replace the journal parts.

**Journal axial play : 0.02 mm (0.0008 in) or less**

- Check the propeller shaft tube surface for dents or cracks. If damage is detected, replace the propeller shaft assembly.

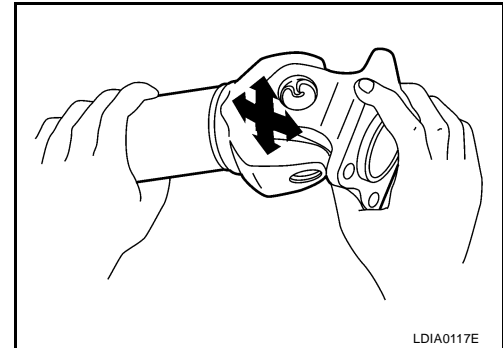

## INSTALLATION

Installation is in the reverse order of removal.

- After installation, check for vibration by driving the vehicle. Refer to [PR-3, "NVH Troubleshooting Chart"](#).

### CAUTION:

**Do not reuse the bolts and nuts. Always install new ones.**

## Disassembly and Assembly

### DISASSEMBLY

EDS001H0

### Journal

1. Put matching marks on the front propeller shaft and flange yoke as shown.

### CAUTION:

**For matching marks, use paint. Never damage the front propeller shaft or flange yoke.**

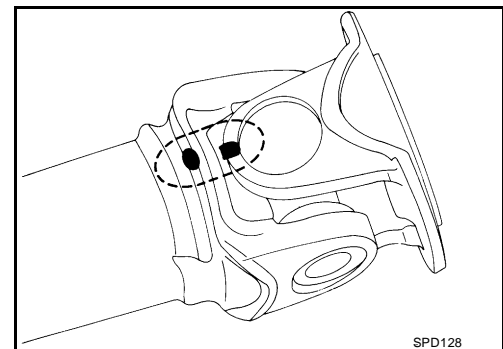

2. Remove the snap rings.

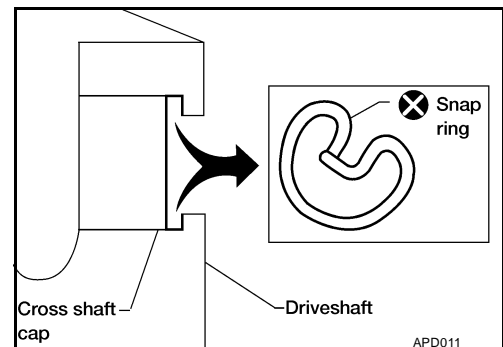

# FRONT PROPELLER SHAFT

3. Push out and remove the journal bearings by lightly tapping the flange yoke with a hammer, taking care not to damage the journal or flange yoke hole.

**NOTE:**

Put marks on the disassembled parts so that they can be reinstalled in their original positions from which they were removed.

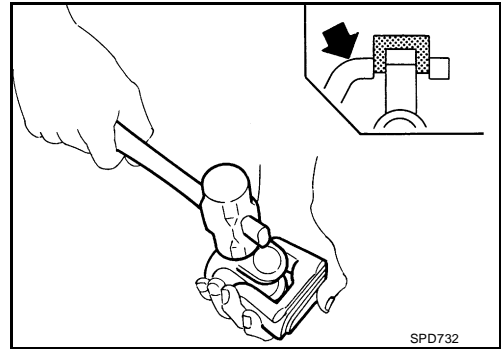

4. Push out and remove the remaining journal bearings at the opposite side by lightly tapping the flange yoke with a hammer, taking care not to damage the journal or flange yoke hole.

**NOTE:**

Put marks on the disassembled parts so that they can be reinstalled in their original positions from which they were removed.

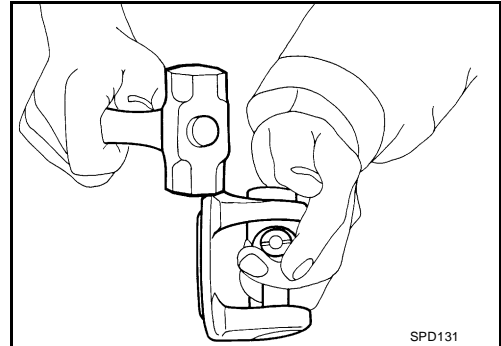

## ASSEMBLY

### Journal

1. Assemble the journal bearings. Apply multipurpose grease on the bearing inner surface.

**NOTE:**

During assembly, use caution so that the needle bearings do not fall down.

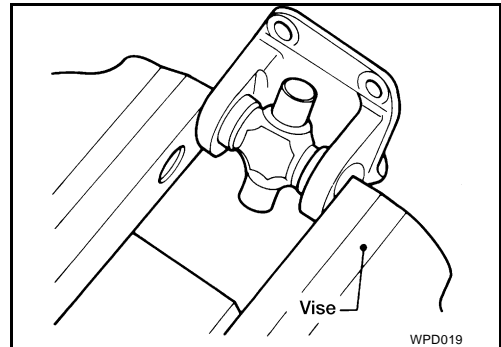

2. Select snap rings that will provide the specified play in an axial direction of the journal, and install them. Refer to [PR-15, "Snap Ring"](#).

**NOTE:**

Select snap rings with a difference in thickness at both sides within 0.02 mm (0.0008 in).

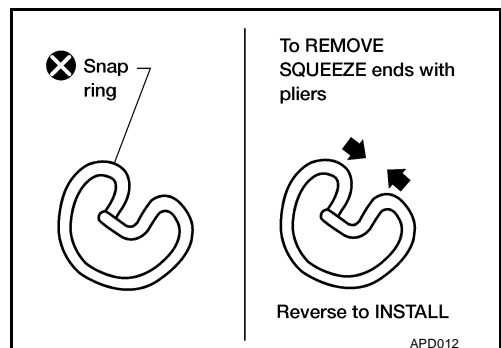

A  
B  
C  
PR  
E  
F  
G  
H  
I  
J  
K  
L  
M

## FRONT PROPELLER SHAFT

3. Adjust the thrust clearance between the bearing and snap ring to zero by tapping the yoke.

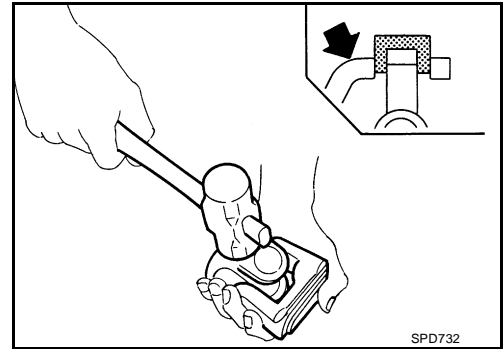

4. Make sure that the journal moves smoothly and is below the joint flex effort specification.

**Joint flex effort : 1.96 N·m (0.20 kg-m, 17 in-lb) or less**

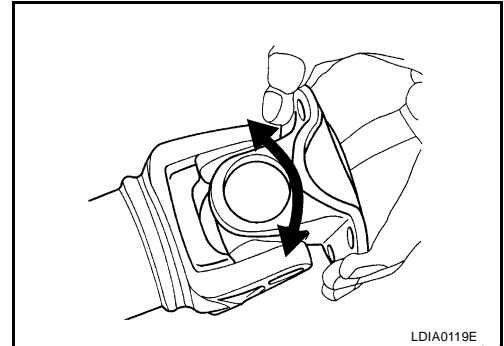



# REAR PROPELLER SHAFT

PFP:37000

## REAR PROPELLER SHAFT

### On-Vehicle Service

EDS001H1

#### APPEARANCE AND NOISE INSPECTION

- Check the propeller shaft tube surface for dents or cracks. If damaged, replace the propeller shaft assembly.
- Check the bearings for noise and damage. Repair or replace the bearings as necessary.

#### PROPELLER SHAFT VIBRATION

If a vibration is present at high speed, inspect the propeller shaft runout first.

1. Measure the runout of the propeller shaft tube at several points by rotating the final drive companion flange with your hands.

##### Propeller shaft runout limit

**4x2 : 1.02 mm (0.0402 in) or less**

**4x4 : 0.6 mm (0.024 in) or less**

2. If the runout exceeds specifications, disconnect the propeller shaft at the final drive companion flange; then rotate the companion flange 90°, 180° and 270° and reconnect the propeller shaft.
3. Check the runout again. If the runout still exceeds specifications, replace the propeller shaft assembly.
4. After installation, check for vibration by driving vehicle.

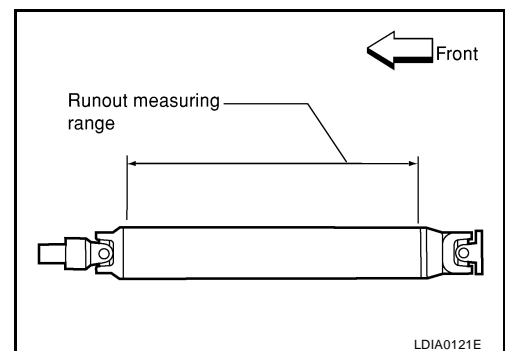
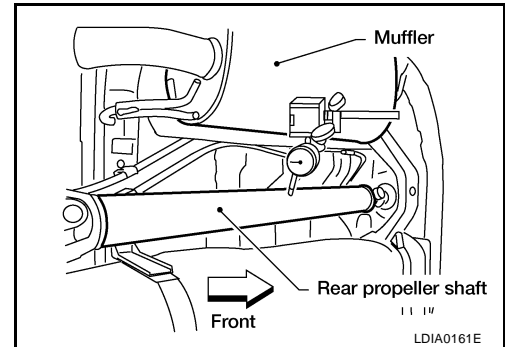

A  
B  
C  
PR  
E  
F  
G  
H  
I  
J  
K  
L  
M

# REAR PROPELLER SHAFT

EDS001H2

## Removal and Installation COMPONENTS

Model 2S1330

SEC. 370

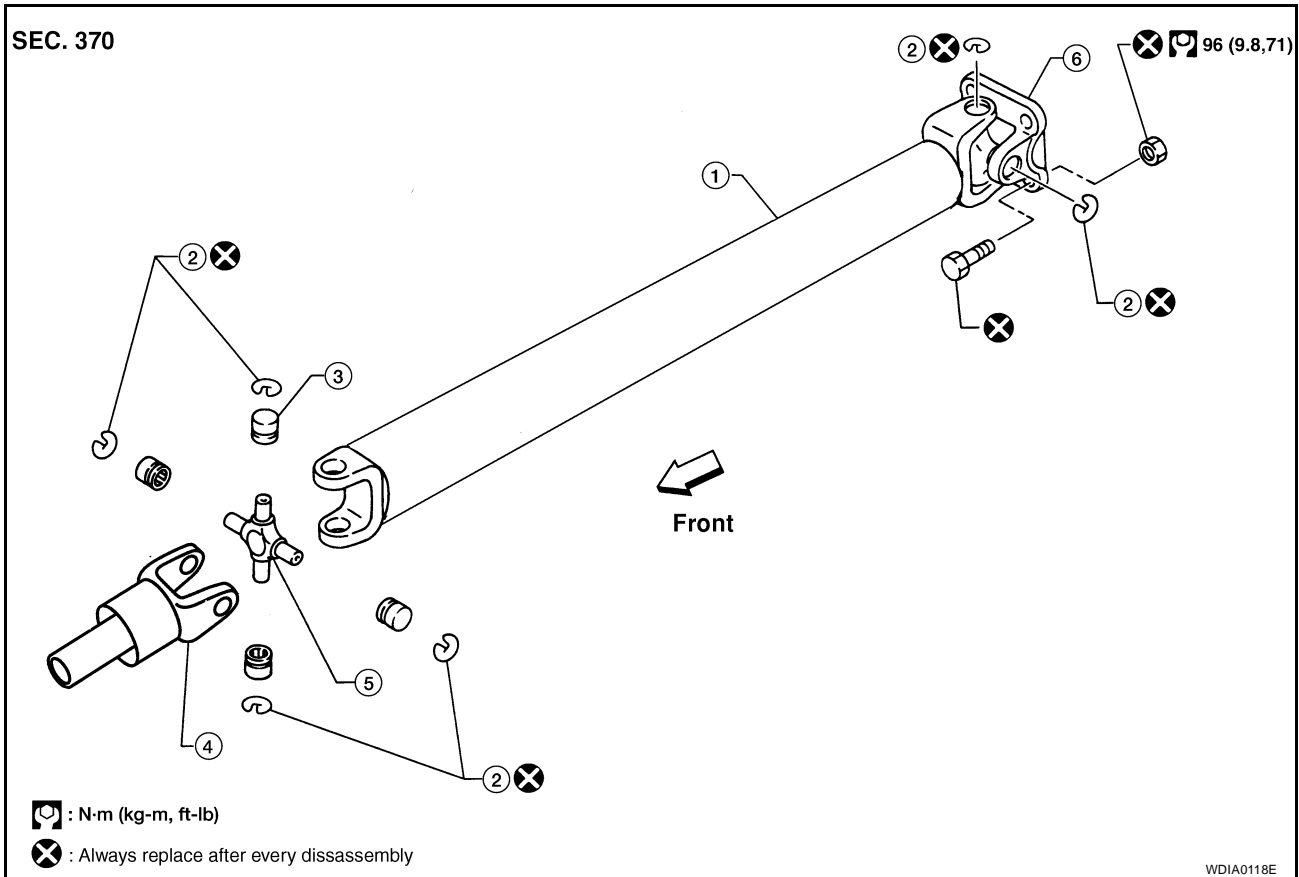

- |                         |              |                    |
|-------------------------|--------------|--------------------|
| 1. Propeller shaft tube | 2. Snap ring | 3. Journal bearing |
| 4. Sleeve yoke          | 5. Journal   | 6. Flange yoke     |

### REMOVAL

1. Move the A/T select lever to the N position and release the parking brake.
2. Put matching marks on the rear propeller shaft flange yoke and the rear final drive companion flange as shown.

**CAUTION:**

**For matching marks, use paint. Never damage the rear propeller shaft flange yoke or the companion flange.**

3. Remove the bolts, then remove the propeller shaft from the rear final drive and A/T or transfer.

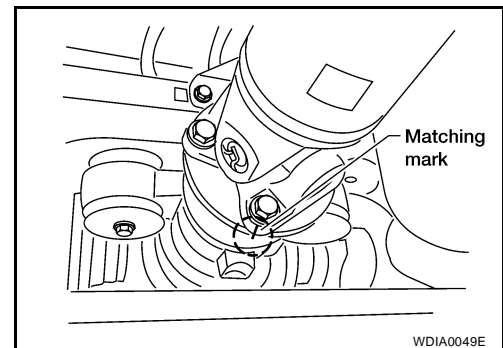

# REAR PROPELLER SHAFT

## INSPECTION

- Inspect the propeller shaft runout. If runout exceeds the limit, replace the propeller shaft assembly.

### Propeller shaft runout limit

**4x2 : 1.02 mm (0.0402 in) or less**

**4x4 : 0.6 mm (0.024 in) or less**

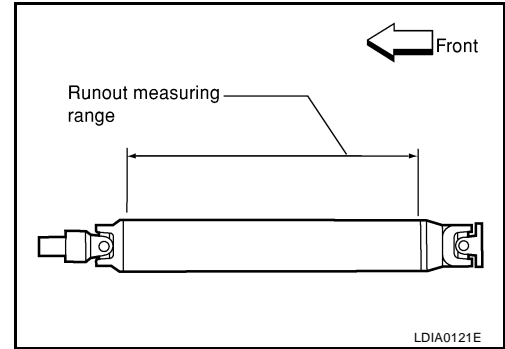

- While holding the flange yoke on one side, check axial play of the joint as shown. If the journal axial play exceeds the specification, repair or replace the journal parts.

**Journal axial play : 0.02 mm (0.0008 in) or less**

- Check the propeller shaft tube for dents or cracks. If damage is detected, replace the propeller shaft assembly.

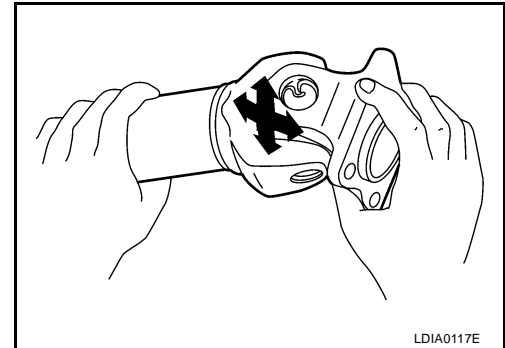

## INSTALLATION

Installation is in the reverse order of removal.

- After installation, check for vibration by driving the vehicle. Refer to [PR-3, "NVH Troubleshooting Chart"](#).

### CAUTION:

**Do not reuse the bolts and nuts. Always install new ones.**

A  
B  
C  
PR  
E  
F  
G  
H  
I  
J  
K  
L  
M

# REAR PROPELLER SHAFT

EDS001H3

## Disassembly and Assembly DISASSEMBLY

### Journal

1. Put matching marks on the rear propeller shaft and flange yoke as shown.

**CAUTION:**

For matching marks use paint. Never damage the rear propeller shaft or flange yoke.

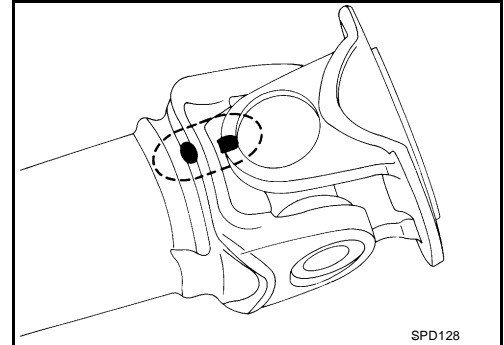

2. Remove the snap rings.

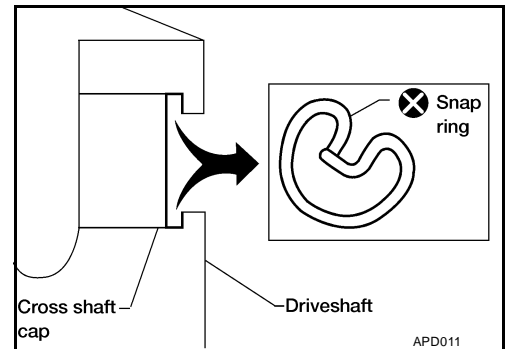

3. Push out and remove the journal bearings by lightly tapping the flange yoke with a hammer, taking care not to damage the journal or flange yoke hole.

**NOTE:**

Put marks on the disassembled parts so that they can be reinstalled in their original positions from which they were removed.

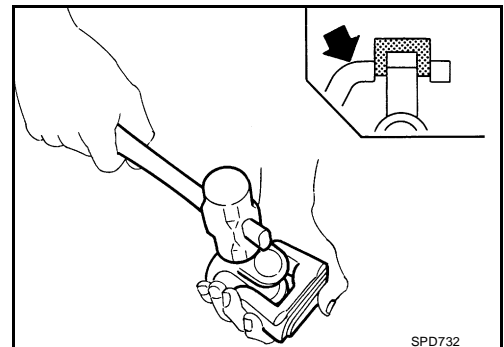

4. Push out and remove the remaining journal bearings at the opposite side by lightly tapping the flange yoke with a hammer, taking care not to damage the journal or flange yoke hole.

**NOTE:**

Put marks on the disassembled parts so that they can be reinstalled in their original positions from which they were removed.

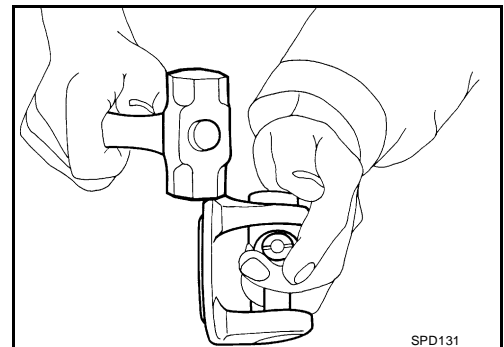

# REAR PROPELLER SHAFT

## ASSEMBLY

### Journal

1. Assemble the journal bearings. Apply multipurpose grease on the bearing inner surface.

**NOTE:**

During assembly, use caution so that the needle bearings do not fall down.

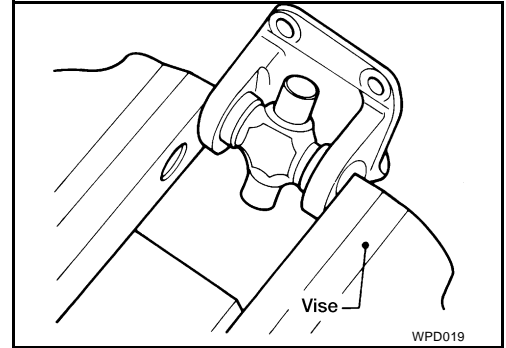

2. Select snap rings that will provide the specified play in an axial direction of the journal, and install them. Refer to [PR-15, "Snap Ring"](#).

**NOTE:**

Select snap rings with a difference in thickness at both sides within 0.02 mm (0.0008 in).

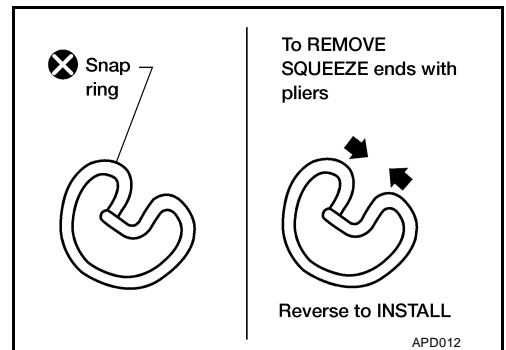

3. Adjust the thrust clearance between the bearing and snap ring to zero by tapping the yoke.

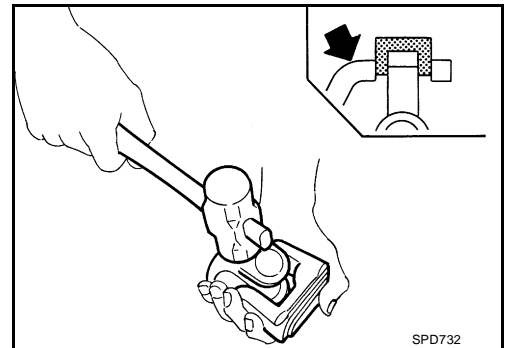

4. Make sure that the journal moves smoothly and is below the joint flex effort specification.

**Joint flex effort : 2.26 N-m (0.23 kg-m, 20 in-lb) or less**

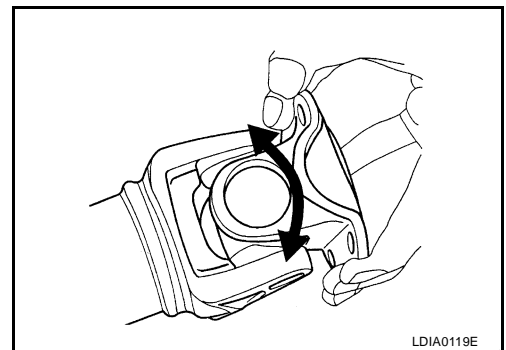

A  
B  
C  
PR  
E  
F  
G  
H  
I  
J  
K  
L  
M

# SERVICE DATA AND SPECIFICATIONS (SDS)

## SERVICE DATA AND SPECIFICATIONS (SDS)

PF0:00030

### General Specifications 4X2 Model

EDS001H4

Applied model	VQ40DE
Propeller shaft model	2S1330 (aluminum tube)
Number of joints	2
Coupling method with rear final drive	Flange type
Coupling method with transmission	Sleeve type
Shaft length (Spider to spider)	1422.2 mm (55.99 in)
Shaft outer diameter	127.6 mm (5.02 in)
Journal axial play	0.02 mm (0.0008 in) or less
Propeller shaft runout limit	1.02 mm (0.0402 in) or less
Propeller shaft joint flex effort	2.26 N·m (0.23 kg-m, 20 in-lb) or less

### 4X4 Model

Applied model	VQ40DE		
Propeller shaft model	Front	Rear	
		Full time 4x4	Part time 4x4
	2F1310	2S1330 (steel tube)	
Number of joints	2		
Coupling method with front final drive	Flange type		
Coupling method with transfer	Flange type	Sleeve type	
Shaft length (Spider to spider)	696 mm (27.40 in)	917.8 mm (36.13 in)	952.8 mm (37.51 in)
Shaft outer diameter	63.5 mm (2.5 in)	76.2 mm (3.00 in)	
Journal axial play	0.02 mm (0.0008 in) or less		
Propeller shaft runout limit	0.6 mm (0.024 in) or less		
Propeller shaft joint flex effort	1.96 N·m (0.20 kg-m, 17 in-lb) or less	2.26 N·m (0.23 kg-m, 20 in-lb) or less	

# SERVICE DATA AND SPECIFICATIONS (SDS)

## Snap Ring

### Model 2F1310 and 2S1330 (4WD)

EDS001H5

Unit: mm (in)

Thickness	Color	Part Number*
1.99 (0.0783)	White	37146-C9400
2.02 (0.0795)	Yellow	37147-C9400
2.05 (0.0807)	Red	37148-C9400
2.08 (0.0819)	Green	37149-C9400
2.11 (0.0831)	Blue	37150-C9400
2.14 (0.0843)	Light brown	37151-C9400
2.17 (0.0854)	Black	37152-C9400
2.20 (0.0866)	No paint	37153-C9400

\*Always check with the Parts Department for the latest parts information.

### Model 2S1330 (2WD)

Unit: mm (in)

Thickness	Color	Part Number*
1.600 - 1.638 (0.0630 - 0.0645)	Black	37146-7S000
1.549 - 1.588 (0.0610 - 0.0625)	Black	37147-7S000
1.524 - 1.562 (0.0600 - 0.0615)	Black	37148-7S000
1.499 - 1.537 (0.0590 - 0.0605)	Black	37149-7S000

\*Always check with the Parts Department for the latest parts information.

# SERVICE DATA AND SPECIFICATIONS (SDS)

---