

# SECTION **ATC**

## AUTOMATIC AIR CONDITIONER

A  
B  
C  
D  
E  
F  
G  
H  
I  
ATC  
K  
L  
M

### CONTENTS

<b>PRECAUTIONS</b> .....	<b>5</b>	<b>OIL</b> .....	<b>22</b>
Precautions for Supplemental Restraint System (SRS) "AIR BAG" and "SEAT BELT PRE-TENSIONER" .....	5	Maintenance of Oil Quantity in Compressor .....	22
Precautions for Working with HFC-134a (R-134a).....	5	OIL .....	22
Contaminated Refrigerant .....	5	CHECKING AND ADJUSTING .....	22
General Refrigerant Precautions .....	6	<b>AIR CONDITIONER CONTROL</b> .....	<b>25</b>
Precautions for Leak Detection Dye .....	6	Description .....	25
A/C Identification Label .....	6	Operation .....	25
Precautions for Refrigerant Connection .....	6	AIR MIX DOORS CONTROL .....	25
FEATURES OF NEW TYPE REFRIGERANT CONNECTION .....	7	BLOWER SPEED CONTROL .....	25
O-RING AND REFRIGERANT CONNECTION.....	8	INTAKE DOOR CONTROL .....	25
Precautions for Servicing Compressor .....	11	MODE DOOR CONTROL .....	25
Precautions for Service Equipment .....	11	DEFROSTER DOOR CONTROL .....	25
RECOVERY/RECYCLING EQUIPMENT .....	11	MAGNET CLUTCH CONTROL .....	26
ELECTRONIC LEAK DETECTOR .....	11	SELF-DIAGNOSTIC SYSTEM .....	26
VACUUM PUMP .....	12	Description of Control System .....	27
MANIFOLD GAUGE SET .....	12	Control Operation .....	27
SERVICE HOSES .....	12	DISPLAY SCREEN .....	28
SERVICE COUPLERS .....	13	AUTO SWITCH .....	28
REFRIGERANT WEIGHT SCALE .....	13	TEMPERATURE CONTROL DIAL (TEMPERATURE CONTROL) (DRIVER SIDE) .....	28
CHARGING CYLINDER .....	13	TEMPERATURE CONTROL DIAL (TEMPERATURE CONTROL) (PASSENGER SIDE) .....	28
<b>PREPARATION</b> .....	<b>14</b>	TEMPERATURE CONTROL DIAL (TEMPERATURE AND MODE CONTROL) (REAR) .....	28
Special Service Tools .....	14	RECIRCULATION ( ) SWITCH .....	28
HFC-134a (R-134a) Service Tools and Equipment..	14	DEFROSTER ( ) SWITCH .....	28
Commercial Service Tools .....	17	REAR WINDOW DEFOGGER SWITCH .....	28
<b>REFRIGERATION SYSTEM</b> .....	<b>18</b>	OFF SWITCH .....	28
Components .....	18	A/C SWITCH .....	28
FRONT REFRIGERATION SYSTEM .....	18	MODE SWITCH (FRONT) .....	28
REAR REFRIGERATION SYSTEM .....	19	FRONT BLOWER CONTROL DIAL .....	28
Refrigerant Cycle .....	20	MODE SWITCH (REAR) .....	28
REFRIGERANT FLOW .....	20	TEMPERATURE CONTROL DIAL (TEMPERATURE AND MODE CONTROL) .....	29
FREEZE PROTECTION .....	20	REAR BLOWER CONTROL DIAL .....	29
Refrigerant System Protection .....	21	Discharge Air Flow .....	30
REFRIGERANT PRESSURE SENSOR .....	21	FRONT .....	30
PRESSURE RELIEF VALVE .....	21	REAR .....	30
		System Description (Front) .....	31
		SWITCHES AND THEIR CONTROL FUNCTION..	31

System Description (Rear) .....	32	SYSTEM DESCRIPTION .....	73
SWITCHES AND THEIR CONTROL FUNCTION..	32	COMPONENT DESCRIPTION .....	74
CAN Communication System Description .....	33	DIAGNOSTIC PROCEDURE FOR INTAKE	
<b>TROUBLE DIAGNOSIS .....</b>	<b>34</b>	DOOR MOTOR .....	74
CONSULT-II Function (BCM) .....	34	Front Blower Motor Circuit .....	75
CONSULT-II BASIC OPERATION .....	34	INSPECTION FLOW .....	75
DATA MONITOR .....	35	SYSTEM DESCRIPTION .....	76
How to Perform Trouble Diagnosis for Quick and		COMPONENT DESCRIPTION .....	77
Accurate Repair .....	36	DIAGNOSTIC PROCEDURE FOR BLOWER	
WORK FLOW .....	36	MOTOR .....	77
SYMPTOM TABLE .....	36	COMPONENT INSPECTION .....	81
Component Parts and Harness Connector Location..	37	Rear Blower Motor Circuit .....	82
ENGINE COMPARTMENT .....	37	INSPECTION FLOW .....	82
FRONT PASSENGER COMPARTMENT .....	38	SYSTEM DESCRIPTION .....	83
REAR PASSENGER COMPARTMENT .....	39	DIAGNOSTIC PROCEDURE FOR REAR	
Schematic .....	40	BLOWER MOTOR .....	83
Wiring Diagram —A/C,A— .....	41	COMPONENT INSPECTION .....	91
Front Air Control Terminals and Reference Value..	49	Rear Air Control Circuit .....	93
PIN CONNECTOR TERMINAL LAYOUT .....	49	INSPECTION FLOW .....	93
TERMINALS AND REFERENCE VALUE FOR		SYSTEM DESCRIPTION .....	94
FRONT AIR CONTROL .....	49	DIAGNOSTIC PROCEDURE FOR REAR AIR	
A/C System Self-diagnosis Function .....	51	CONTROL .....	94
DESCRIPTION .....	51	Magnet Clutch Circuit .....	96
Operational Check (Front) .....	53	INSPECTION FLOW .....	96
CHECKING MEMORY FUNCTION .....	53	SYSTEM DESCRIPTION .....	97
CHECKING BLOWER .....	53	DIAGNOSTIC PROCEDURE FOR MAGNET	
CHECKING DISCHARGE AIR .....	53	CLUTCH .....	97
CHECKING RECIRCULATION .....	53	Insufficient Cooling .....	102
CHECKING TEMPERATURE DECREASE .....	54	INSPECTION FLOW .....	102
CHECKING TEMPERATURE INCREASE .....	54	PERFORMANCE TEST DIAGNOSES .....	103
CHECK A/C SWITCH .....	54	PERFORMANCE CHART .....	105
CHECKING AUTO MODE .....	54	TROUBLE DIAGNOSES FOR UNUSUAL PRES-	
Operational Check (Rear) .....	55	SURE .....	106
CHECKING BLOWER .....	55	Insufficient Heating .....	109
CHECKING TEMPERATURE DECREASE .....	55	INSPECTION FLOW .....	109
CHECKING TEMPERATURE INCREASE .....	55	Heater Pump Circuit .....	110
Power Supply and Ground Circuit for Front Air Con-		SYSTEM DESCRIPTION .....	110
trol .....	56	DIAGNOSTIC PROCEDURE FOR HEATER	
INSPECTION FLOW .....	56	PUMP CIRCUIT .....	111
COMPONENT DESCRIPTION .....	57	COMPONENT INSPECTION .....	112
DIAGNOSTIC PROCEDURE FOR A/C SYSTEM..	57	Noise .....	113
Mode Door Motor Circuit .....	59	INSPECTION FLOW .....	113
INSPECTION FLOW .....	59	Self-diagnosis .....	115
SYSTEM DESCRIPTION .....	60	INSPECTION FLOW .....	115
COMPONENT DESCRIPTION .....	61	Memory Function .....	116
DIAGNOSTIC PROCEDURE FOR MODE		INSPECTION FLOW .....	116
DOOR MOTOR .....	61	Ambient Sensor 1 Circuit .....	117
Air Mix Door Motor Circuit .....	63	COMPONENT DESCRIPTION .....	117
INSPECTION FLOW .....	63	AMBIENT TEMPERATURE INPUT PROCESS..	117
SYSTEM DESCRIPTION .....	64	DIAGNOSTIC PROCEDURE FOR AMBIENT	
COMPONENT DESCRIPTION .....	65	SENSOR 1 .....	117
DIAGNOSTIC PROCEDURE FOR AIR MIX		COMPONENT INSPECTION .....	119
DOOR MOTOR (DRIVER) .....	65	In-vehicle Sensor Circuit .....	120
DIAGNOSTIC PROCEDURE FOR AIR MIX		COMPONENT DESCRIPTION .....	120
DOOR MOTOR (PASSENGER) .....	67	DIAGNOSTIC PROCEDURE FOR IN-VEHICLE	
DIAGNOSTIC PROCEDURE FOR AIR MIX		SENSOR .....	120
DOOR MOTOR (REAR) .....	69	COMPONENT INSPECTION .....	122
Intake Door Motor Circuit .....	72	Optical Sensor Circuit .....	123
INSPECTION FLOW .....	72	COMPONENT DESCRIPTION .....	123

OPTICAL INPUT PROCESS .....	123	<b>MODE DOOR MOTOR .....</b>	<b>144</b>	
DIAGNOSTIC PROCEDURE FOR OPTICAL SENSOR .....	123	Removal and Installation .....	144	A
Intake Sensor Circuit .....	125	REMOVAL .....	144	
COMPONENT DESCRIPTION .....	125	INSTALLATION .....	144	
DIAGNOSTIC PROCEDURE FOR INTAKE SEN- SOR .....	125	<b>AIR MIX DOOR MOTOR .....</b>	<b>145</b>	B
COMPONENT INSPECTION .....	126	Components .....	145	
<b>CONTROL UNIT .....</b>	<b>127</b>	Removal and Installation .....	145	
Removal and Installation .....	127	FRONT AIR MIX DOOR MOTOR (DRIVER) ....	145	C
FRONT AIR CONTROL .....	127	FRONT AIR MIX DOOR MOTOR (PASSENGER)	145	
REAR AIR CONTROL .....	127	REAR AIR MIX DOOR MOTOR .....	146	
<b>AMBIENT SENSOR .....</b>	<b>128</b>	<b>VARIABLE BLOWER CONTROL .....</b>	<b>147</b>	D
Removal and Installation .....	128	Removal and Installation .....	147	
REMOVAL .....	128	REMOVAL .....	147	
INSTALLATION .....	128	INSTALLATION .....	147	
<b>IN-VEHICLE SENSOR .....</b>	<b>129</b>	<b>REAR BLOWER MOTOR RESISTOR .....</b>	<b>148</b>	E
Removal and Installation .....	129	Removal and Installation .....	148	
REMOVAL .....	129	REMOVAL .....	148	
INSTALLATION .....	129	INSTALLATION .....	148	F
<b>OPTICAL SENSOR .....</b>	<b>130</b>	<b>DUCTS AND GRILLES .....</b>	<b>149</b>	
Removal and Installation .....	130	Components .....	149	
<b>INTAKE SENSOR .....</b>	<b>131</b>	Removal and Installation .....	151	G
Removal and Installation .....	131	DEFROSTER NOZZLE .....	151	
REMOVAL .....	131	RH AND LH SIDE DEMISTER DUCT .....	151	
INSTALLATION .....	131	RH AND LH VENTILATOR DUCT .....	152	H
<b>BLOWER MOTOR .....</b>	<b>132</b>	CENTER VENTILATOR DUCT .....	152	
Components .....	132	FLOOR CONNECTOR DUCT .....	152	
Removal and Installation .....	132	FRONT AND REAR FLOOR DUCTS .....	152	
FRONT BLOWER MOTOR .....	132	REAR OVERHEAD DUCTS .....	152	
REAR BLOWER MOTOR .....	133	SIDE REAR FLOOR DUCT .....	153	I
<b>IN-CABIN MICROFILTER .....</b>	<b>134</b>	GRILLES .....	153	
Removal and Installation .....	134	<b>REFRIGERANT LINES .....</b>	<b>154</b>	ATC
FUNCTION .....	134	HFC-134a (R-134a) Service Procedure .....	154	
REPLACEMENT TIMING .....	134	SETTING OF SERVICE TOOLS AND EQUIP- MENT .....	154	
REPLACEMENT PROCEDURE .....	134	Components .....	156	K
<b>HEATER &amp; COOLING UNIT ASSEMBLY .....</b>	<b>136</b>	Removal and Installation for Compressor .....	158	
Components .....	136	REMOVAL .....	158	
Removal and Installation .....	137	INSTALLATION .....	158	L
FRONT HEATER AND COOLING UNIT ASSEM- BLY .....	137	Removal and Installation for Compressor Clutch ..	159	
REAR HEATER AND COOLING UNIT ASSEM- BLY .....	138	REMOVAL .....	159	
<b>HEATER CORE .....</b>	<b>140</b>	INSPECTION .....	160	M
Components .....	140	INSTALLATION .....	160	
Removal and Installation .....	141	BREAK-IN OPERATION .....	162	
FRONT HEATER CORE .....	141	Removal and Installation for Front High-pressure Flexible A/C Hose .....	162	
REAR HEATER CORE .....	141	REMOVAL .....	162	
<b>HEATER PUMP .....</b>	<b>142</b>	INSTALLATION .....	162	
Removal and Installation .....	142	Removal and Installation for Front High-pressure A/C Pipe .....	162	
REMOVAL .....	142	REMOVAL .....	162	
INSTALLATION .....	142	INSTALLATION .....	162	
<b>INTAKE DOOR MOTOR .....</b>	<b>143</b>	Removal and Installation for Front Low-pressure Flexible A/C Hose .....	162	
Removal and Installation .....	143	REMOVAL .....	162	
REMOVAL .....	143	INSTALLATION .....	162	
INSTALLATION .....	143	Removal and Installation for Front Low-pressure A/ C Pipe .....	163	
		REMOVAL .....	163	
		INSTALLATION .....	163	

Removal and Installation for Rear High- and Low-pressure A/C Pipes .....	163	Removal and Installation for Front Expansion Valve	169
REMOVAL .....	163	REMOVAL .....	169
INSTALLATION .....	163	INSTALLATION .....	169
Removal and Installation for Underfloor Rear High- and Low-pressure A/C and Heater Core Pipes ...	163	Removal and Installation for Rear Expansion Valve	169
REMOVAL .....	163	REMOVAL .....	169
INSTALLATION .....	165	INSTALLATION .....	169
Removal and Installation for Refrigerant Pressure Sensor .....	165	Checking for Refrigerant Leaks .....	170
REMOVAL .....	165	Checking System for Leaks Using the Fluorescent Dye Leak Detector .....	170
INSTALLATION .....	165	Dye Injection .....	170
Removal and Installation for Condenser .....	165	Electronic Refrigerant Leak Detector .....	171
REMOVAL .....	165	PRECAUTIONS FOR HANDLING LEAK DETECTOR .....	171
INSTALLATION .....	165	CHECKING PROCEDURE .....	172
Removal and Installation for Front Evaporator ....	166	<b>SERVICE DATA AND SPECIFICATIONS (SDS) ...</b>	<b>174</b>
REMOVAL .....	167	Service Data and Specifications (SDS) .....	174
INSTALLATION .....	167	COMPRESSOR .....	174
Removal and Installation for Rear Evaporator ....	168	OIL .....	174
REMOVAL .....	168	REFRIGERANT .....	174
INSTALLATION .....	169	ENGINE IDLING SPEED .....	174
		BELT TENSION .....	174

# PRECAUTIONS

## PRECAUTIONS

PFP:00001

### Precautions for Supplemental Restraint System (SRS) “AIR BAG” and “SEAT BELT PRE-TENSIONER”

EJS00406

The Supplemental Restraint System such as “AIR BAG” and “SEAT BELT PRE-TENSIONER”, used along with a front seat belt, helps to reduce the risk or severity of injury to the driver and front passenger for certain types of collision. This system includes seat belt switch inputs and dual stage front air bag modules. The SRS system uses the seat belt switches to determine the front air bag deployment, and may only deploy one front air bag, depending on the severity of a collision and whether the front occupants are belted or unbelted. Information necessary to service the system safely is included in the SRS and SB section of this Service Manual.

#### **WARNING:**

- To avoid rendering the SRS inoperative, which could increase the risk of personal injury or death in the event of a collision which would result in air bag inflation, all maintenance must be performed by an authorized NISSAN/INFINITI dealer.
- Improper maintenance, including incorrect removal and installation of the SRS, can lead to personal injury caused by unintentional activation of the system. For removal of Spiral Cable and Air Bag Module, see the SRS section.
- Do not use electrical test equipment on any circuit related to the SRS unless instructed to in this Service Manual. SRS wiring harnesses can be identified by yellow and/or orange harnesses or harness connectors.

### Precautions for Working with HFC-134a (R-134a)

EJS00407

#### **WARNING:**

- CFC-12 (R-12) refrigerant and HFC-134a (R-134a) refrigerant are not compatible. If the refrigerants are mixed compressor failure is likely to occur. Refer [ATC-5, "Contaminated Refrigerant"](#) . To determine the purity of HFC-134a (R-134a) in the vehicle and recovery tank, use refrigerant recovery/recycling equipment and refrigerant identifier.
- Use only specified oil for the HFC-134a (R-134a) A/C system and HFC-134a (R-134a) components. If oil other than that specified is used, compressor failure is likely to occur.
- The specified HFC-134a (R-134a) oil rapidly absorbs moisture from the atmosphere. The following handling precautions must be observed:
  - When removing refrigerant components from a vehicle, immediately cap (seal) the component to minimize the entry of moisture from the atmosphere.
  - When installing refrigerant components to a vehicle, do not remove the caps (unseal) until just before connecting the components. Connect all refrigerant loop components as quickly as possible to minimize the entry of moisture into system.
  - Only use the specified oil from a sealed container. Immediately reseal containers of oil. Without proper sealing, oil will become moisture saturated and should not be used.
  - Avoid breathing A/C refrigerant and oil vapor or mist. Exposure may irritate eyes, nose and throat. Remove HFC-134a (R-134a) from the A/C system using certified service equipment meeting requirements of SAE J2210 [HFC-134a (R-134a) recycling equipment], or SAE J2209 [HFC-134a (R-134a) recovery equipment]. If accidental system discharge occurs, ventilate work area before resuming service. Additional health and safety information may be obtained from refrigerant and oil manufacturers.
  - Do not allow the refrigerant oil to come in contact with styrofoam parts. Damage may result.

### Contaminated Refrigerant

EJS00408

If a refrigerant other than pure HFC-134a (R-134a) is identified in a vehicle, your options are:

- Explain to the customer that environmental regulations prohibit the release of contaminated refrigerant into the atmosphere.
- Explain that recovery of the contaminated refrigerant could damage your service equipment and refrigerant supply.
- Suggest the customer return the vehicle to the location of previous service where the contamination may have occurred.
- If you choose to perform the repair, recover the refrigerant using only **dedicated equipment and containers**. **Do not recover contaminated refrigerant into your existing service equipment**. If your facility

A  
B  
C  
D  
E  
F  
G  
H  
I  
K  
L  
M

ATC

# PRECAUTIONS

does not have dedicated recovery equipment, you may contact a local refrigerant product retailer for available service. This refrigerant must be disposed of in accordance with all federal and local regulations. In addition, replacement of all refrigerant system components on the vehicle is recommended.

- If the vehicle is within the warranty period, the air conditioner warranty is void. Please contact NISSAN Customer Affairs for further assistance.

## General Refrigerant Precautions

EJS00409

### WARNING:

- Do not release refrigerant into the air. Use approved recovery/recycling equipment to capture the refrigerant every time an air conditioning system is discharged.
- Always wear eye and hand protection (goggles and gloves) when working with any refrigerant or air conditioning system.
- Do not store or heat refrigerant containers above 52°C (125°F).
- Do not heat a refrigerant container with an open flame; if container warming is required, place the bottom of the container in a warm pail of water.
- Do not intentionally drop, puncture, or incinerate refrigerant containers.
- Keep refrigerant away from open flames: poisonous gas will be produced if refrigerant burns.
- Refrigerant will displace oxygen, therefore be certain to work in well ventilated areas to prevent suffocation.
- Do not pressure test or leak test HFC-134a (R-134a) service equipment and/or vehicle air conditioning systems with compressed air during repair. Some mixtures of air and HFC-134a (R-134a) have been shown to be combustible at elevated pressures. These mixtures, if ignited, may cause injury or property damage. Additional health and safety information may be obtained from refrigerant manufacturers.

## Precautions for Leak Detection Dye

EJS0040A

- The A/C system contains a fluorescent leak detection dye used for locating refrigerant leaks. An ultraviolet (UV) lamp is required to illuminate the dye when inspecting for leaks.
- Always wear fluorescence enhancing UV safety goggles to protect your eyes and enhance the visibility of the fluorescent dye.
- The fluorescent dye leak detector is not a replacement for an electronic refrigerant leak detector. The fluorescent dye leak detector should be used in conjunction with an electronic refrigerant leak detector (J-41995).
- For your safety and the customer's satisfaction, read and follow all manufacturer's operating instructions and precautions prior to performing work.
- A compressor shaft seal should not be repaired because of dye seepage. The compressor shaft seal should only be repaired after confirming the leak with an electronic refrigerant leak detector (J-41995).
- Always remove any remaining dye from the leak area after repairs are complete to avoid a misdiagnosis during a future service.
- Do not allow dye to come into contact with painted body panels or interior components. If dye is spilled, clean immediately with the approved dye cleaner. Fluorescent dye left on a surface for an extended period of time **cannot be removed**.
- Do not spray the fluorescent dye cleaning agent on hot surfaces (engine exhaust manifold, etc.).
- Do not use more than one refrigerant dye bottle (1/4 ounce / 7.4 cc) per A/C system.
- Leak detection dyes for HFC-134a (R-134a) and CFC-12 (R-12) A/C systems are different. Do not use HFC-134a (R-134a) leak detection dye in CFC-12 (R-12) A/C systems or CFC-12 (R-12) leak detection dye in HFC-134a (R-134a) A/C systems or A/C system damage may result.
- The fluorescent properties of the dye will remain for over three (3) years unless a compressor failure occurs.

## A/C Identification Label

EJS0040B

Vehicles with factory installed fluorescent dye have this identification label on the underside of hood.

## Precautions for Refrigerant Connection

EJS0040C

A new type refrigerant connection has been introduced to all refrigerant lines except the following locations.

# PRECAUTIONS

- Expansion valve to cooling unit
- Evaporator pipes to evaporator (inside cooling unit)
- Refrigerant pressure sensor

## FEATURES OF NEW TYPE REFRIGERANT CONNECTION

- The O-ring has been relocated. It has also been provided with a groove for proper installation. This reduces the possibility of the O-ring being caught in, or damaged by, the mating part. The sealing direction of the O-ring is now set vertically in relation to the contacting surface of the mating part to improve sealing characteristics.
- The reaction force of the O-ring will not occur in the direction that causes the joint to pull out, thereby facilitating piping connections.

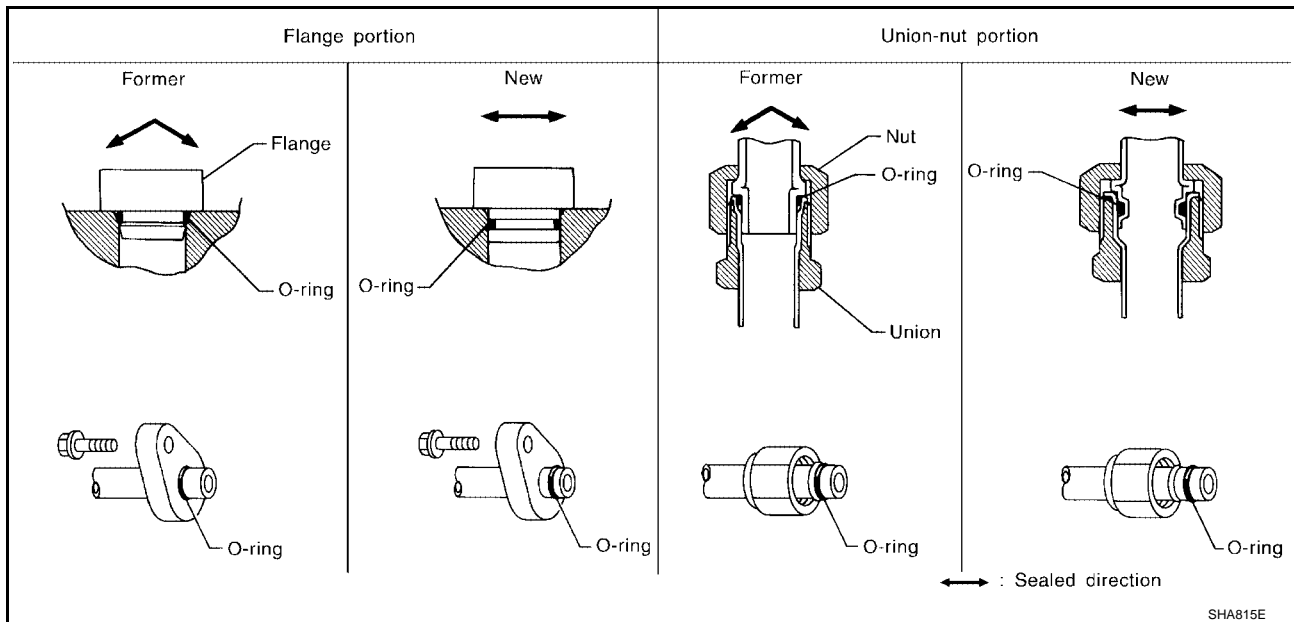

A  
B  
C  
D  
E  
F  
G  
H  
I

ATC

K  
L  
M

# PRECAUTIONS

## O-RING AND REFRIGERANT CONNECTION

### Front A/C Compressor and Condenser

SEC. 270 • 271 • 274 • 276 • 278

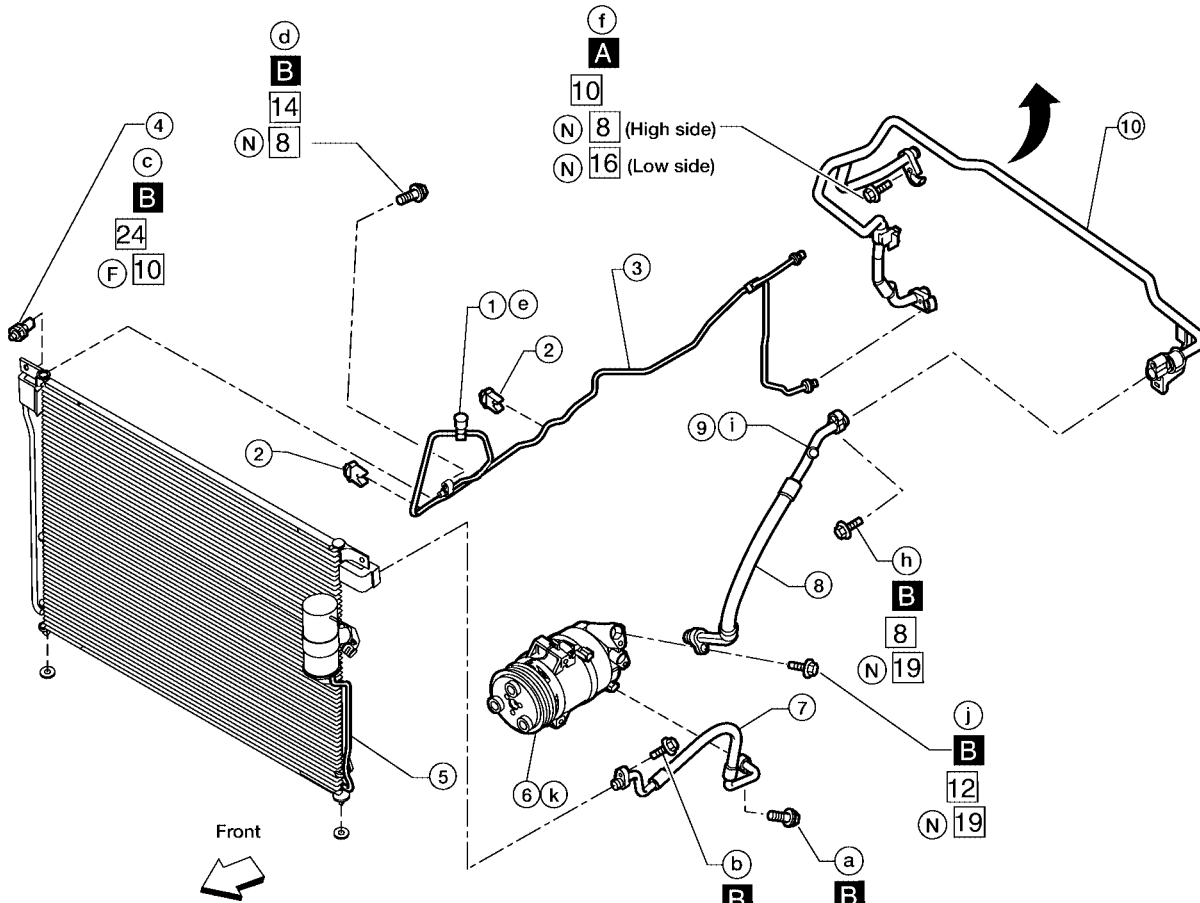
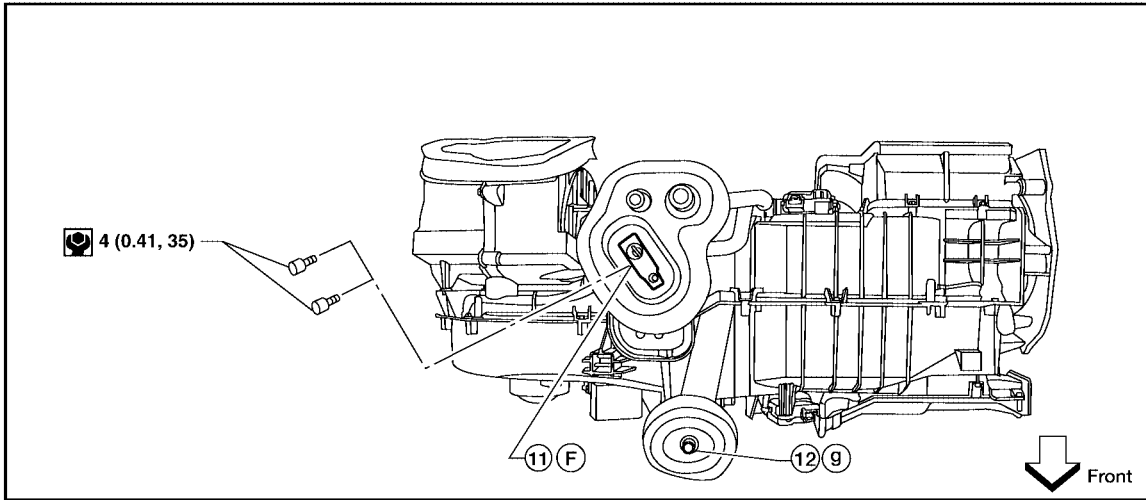

- : Refrigerant leak checking order (a-k)
- : Tightening torque
- : Wrench size
- : O-ring size
- ⊕ : N-m (kg-m, in-lb)
- A** : 3.4 (0.35, 30)
- B** : 9.3 (0.95, 82)
- (F) : Former type refrigerant connection
- (N) : New type refrigerant connection

WJIA1399E





# PRECAUTIONS

## O-Ring Part Numbers and Specifications

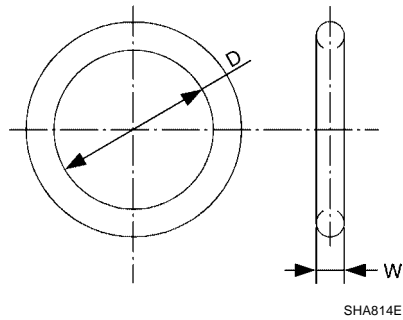

Connec- tion type	O-ring size	Part number*	D mm (in)	W mm (in)
New	8	92471 N8210	6.8 (0.268)	1.85 (0.0728)
Former	10	J2476 89956	9.25 (0.3642)	1.78 (0.0701)
New	12	92472 N8210	10.9 (0.429)	2.43 (0.0957)
Former		92475 71L00	11.0 (0.433)	2.4 (0.094)
New	16	92473 N8210	13.6 (0.535)	2.43 (0.0957)
Former		92475 72L00	14.3 (0.563)	2.3 (0.091)
New	19	92474 N8210	16.5 (0.650)	2.43 (0.0957)
Former		92477 N8200	17.12 (0.6740)	1.78 (0.0701)
New	24	92195 AH300	21.8 (0.858)	2.4 (0.094)

\*: Always check with the Parts Department for the latest parts information.

### WARNING:

Make sure all refrigerant is discharged into the recycling equipment and the pressure in the system is less than atmospheric pressure. Then gradually loosen the discharge side hose fitting and remove it.

### CAUTION:

When replacing or cleaning refrigerant cycle components, observe the following.

- When the compressor is removed, store it in the same position as it is when mounted on the car. Failure to do so will cause oil to enter the low pressure chamber.
- When connecting tubes, always use a torque wrench and a back-up wrench.
- After disconnecting tubes, immediately plug all openings to prevent entry of dirt and moisture.
- When installing an air conditioner in the vehicle, connect the pipes as the final stage of the operation. Do not remove the seal caps of pipes and other components until just before required for connection.
- Allow components stored in cool areas to warm to working area temperature before removing seal caps. This prevents condensation from forming inside A/C components.
- Thoroughly remove moisture from the refrigeration system before charging the refrigerant.
- Always replace used O-rings.
- When connecting tube, apply oil to circle of the O-rings shown in illustration. Be careful not to apply oil to threaded portion.  
Oil name: NISSAN A/C System Oil Type S or equivalent.
- O-ring must be closely attached to dented portion of tube.
- When replacing the O-ring, be careful not to damage O-ring and tube.
- Connect tube until you hear it click, then tighten the nut or bolt by hand until snug. Make sure that the O-ring is installed to tube correctly.
- After connecting line, conduct leak test and make sure that there is no leakage from connections. When the refrigerant leaking point is found, disconnect that line and replace the O-ring. Then tighten connections of seal seat to the specified torque.

# PRECAUTIONS

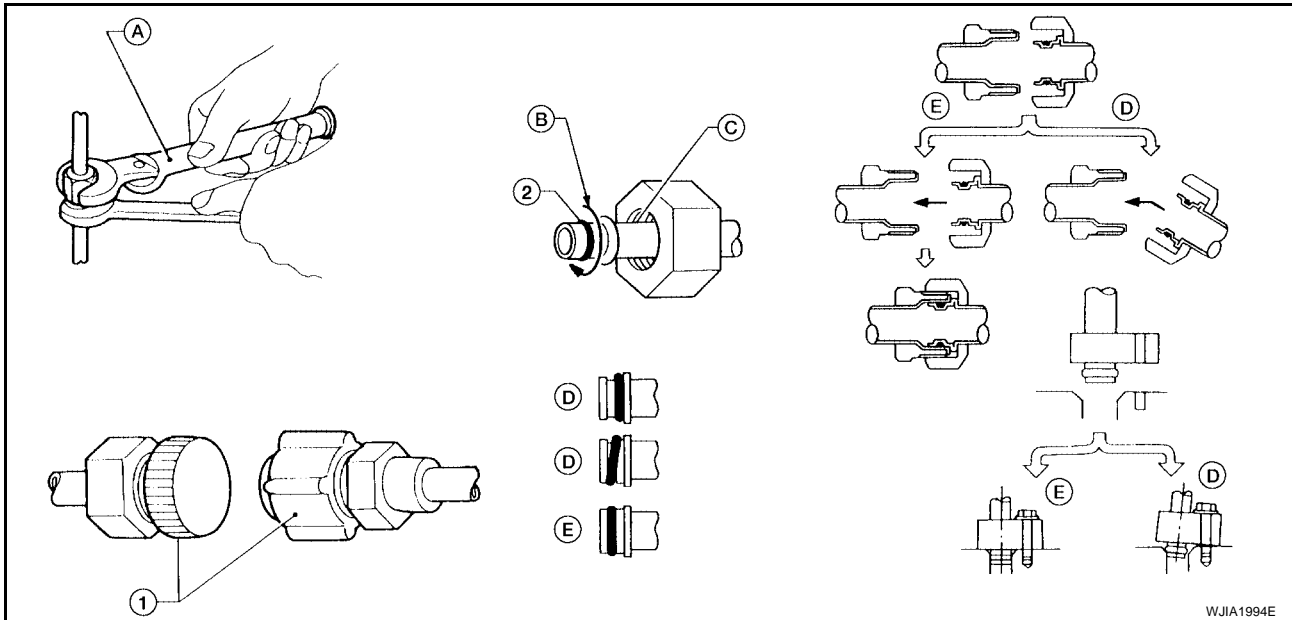

- |              |                               |                  |
|--------------|-------------------------------|------------------|
| 1. Plug      | 2. O-ring                     | A. Torque wrench |
| B. Apply oil | C. Do not apply oil to thread | D. No good       |
| E. Good      |                               |                  |

## Precautions for Servicing Compressor

EJS0040D

- Plug all openings to prevent moisture and foreign matter from entering.
- When the compressor is removed, store it in the same position as it is when mounted on the car.
- When replacing or repairing compressor, follow "Maintenance of Oil Quantity in Compressor" exactly. Refer to [ATC-22, "Maintenance of Oil Quantity in Compressor"](#).
- Keep friction surfaces between clutch and pulley clean. If the surface is contaminated with oil, wipe it off by using a clean waste cloth moistened with thinner.
- After compressor service operation, turn the compressor shaft by hand more than 5 turns in both directions. This will equally distribute oil inside the compressor. After the compressor is installed, let the engine idle and operate the compressor for 1 hour.
- After replacing the compressor magnet clutch, apply voltage to the new one and check for normal operation. Refer to [ATC-159, "Removal and Installation for Compressor Clutch"](#).

## Precautions for Service Equipment RECOVERY/RECYCLING EQUIPMENT

EJS0040E

Follow the manufacturer's instructions for machine operation and machine maintenance. Never introduce any refrigerant other than that specified into the machine.

## ELECTRONIC LEAK DETECTOR

Follow the manufacturer's instructions for tester operation and tester maintenance.

# PRECAUTIONS

## VACUUM PUMP

The oil contained inside the vacuum pump is not compatible with the specified oil for HFC-134a (R-134a) A/C systems. The vent side of the vacuum pump is exposed to atmospheric pressure so the vacuum pump oil may migrate out of the pump into the service hose. This is possible when the pump is switched off after evacuation (vacuuming) and hose is connected to it.

To prevent this migration, use a manual valve situated near the hose-to-pump connection, as follows.

- Usually vacuum pumps have a manual isolator valve as part of the pump. Close this valve to isolate the service hose from the pump.
- For pumps without an isolator, use a hose equipped with a manual shut-off valve near the pump end. Close the valve to isolate the hose from the pump.
- If the hose has an automatic shut off valve, disconnect the hose from the pump: as long as the hose is connected, the valve is open and lubricating oil may migrate.

Some one-way valves open when vacuum is applied and close under a no vacuum condition. Such valves may restrict the pump's ability to pull a deep vacuum and are not recommended.

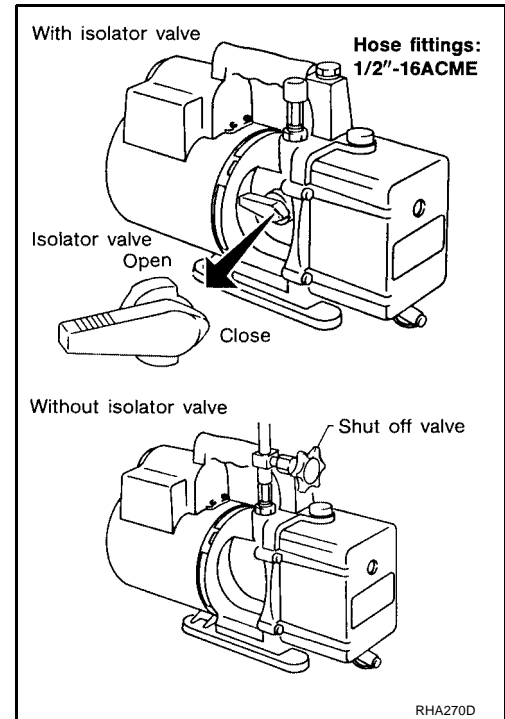

## MANIFOLD GAUGE SET

Be certain that the gauge face indicates HFC-134a (R-134a). Make sure the gauge set has 1/2"-16 ACME threaded connections for service hoses. Confirm the set has been used only with refrigerant HFC-134a (R-134a) along with specified oil.

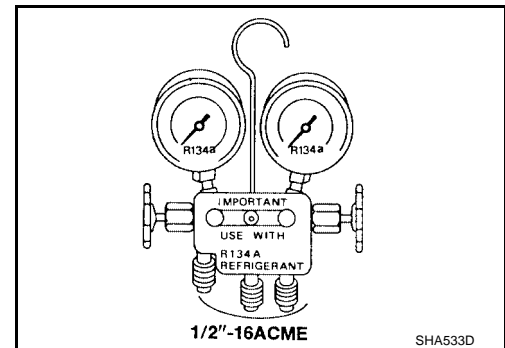

## SERVICE HOSES

Be certain that the service hoses display the markings described (colored hose with black stripe). All hoses must include positive shut-off devices (either manual or automatic) near the end of the hoses opposite the manifold gauge.

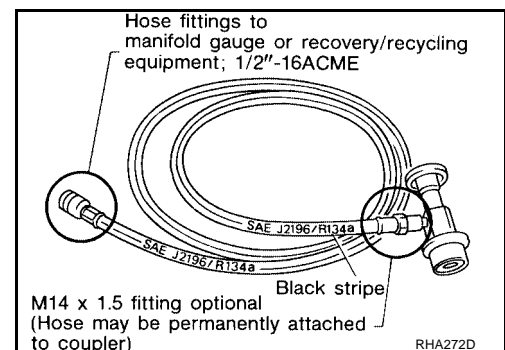

# PRECAUTIONS

## SERVICE COUPLERS

Never attempt to connect HFC-134a (R-134a) service couplers to a CFC-12 (R-12) A/C system. The HFC-134a (R-134a) couplers will not properly connect to the CFC-12 (R-12) system. If an improper connection is attempted, discharging and contamination may occur.

Shut-off valve rotation	A/C service valve
Clockwise	Open
Counterclockwise	Close

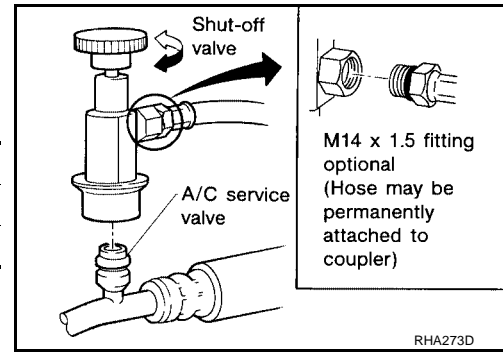

## REFRIGERANT WEIGHT SCALE

Verify that no refrigerant other than HFC134a (R-134a) and specified oils have been used with the scale. If the scale controls refrigerant flow electronically, the hose fitting must be 1/2"-16 ACME.

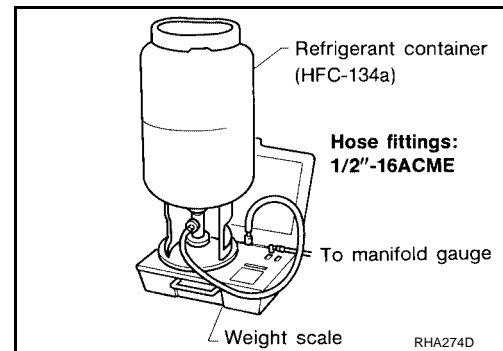

## CHARGING CYLINDER

Using a charging cylinder is not recommended. Refrigerant may be vented into air from cylinder's top valve when filling the cylinder with refrigerant. Also, the accuracy of the cylinder is generally less than that of an electronic scale or of quality recycle/recharge equipment.

A  
B  
C  
D  
E  
F  
G  
H  
I  
K  
L  
M

ATC

# PREPARATION

## PREPARATION

PFP:00002

### Special Service Tools

EJS0040G

The actual shapes of Kent-Moore tools may differ from those of special service tools illustrated here.

Tool number (Kent-Moore No.) Tool name	Description
— (J-38873-A) Pulley installer	Installing pulley
KV99233130 (J-29884) Pulley puller	Removing pulley

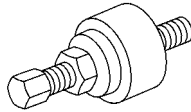

LHA171

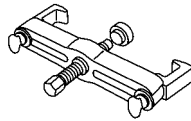

LHA172

## HFC-134a (R-134a) Service Tools and Equipment

EJS0040H

Never mix HFC-134a (R-134a) refrigerant and/or its specified oil with CFC-12 (R-12) refrigerant and/or its oil. Separate and non-interchangeable service equipment must be used for handling each type of refrigerant/oil. Refrigerant container fittings, service hose fittings and service equipment fittings (equipment which handles refrigerant and/or oil) are different between CFC-12 (R-12) and HFC-134a (R-134a). This is to avoid mixed use of the refrigerants/oil.

Adapters that convert one size fitting to another must never be used refrigerant/oil contamination will occur and compressor failure will result.

Tool number (Kent-Moore No.) Tool name	Description
HFC-134a (R-134a) ( — ) Refrigerant	Container color: Light blue Container marking: HFC-134a (R-134a) Fitting size: Thread size ● large container 1/2"-16 ACME
— ( — ) NISSAN A/C System Oil Type S	Type: Poly alkylene glycol oil (PAG), type S Application: HFC-134a (R-134a) swash plate compressors (NISSAN only) Lubricity: 40 m ℓ (1.4 US fl oz, 1.4 Imp fl oz)
KV991J0130 (ACR2005-NI) ACR A/C Service Center	Refrigerant Recovery and Recycling and Recharging

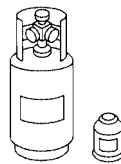

S-NT196





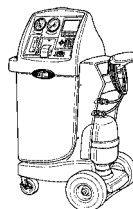

S-NT197

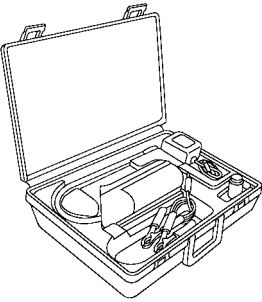
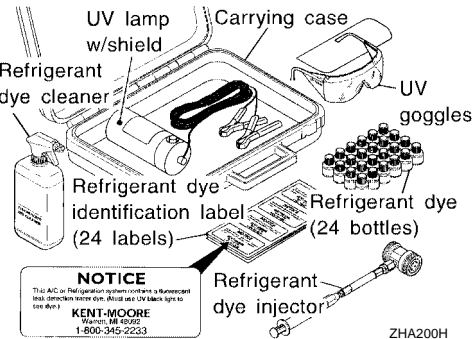
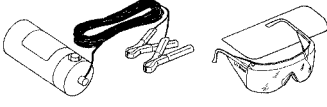

WJIA0293E

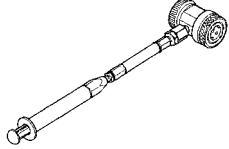

# PREPARATION

Tool number (Kent-Moore No.) Tool name	Description
<p>— (J-41995) Electronic refrigerant leak detector</p>	<p>Power supply: ● DC 12V (battery terminal)</p>  <p style="text-align: right;">AHA281A</p>
<p>— (J-43926) Refrigerant dye leak detection kit Kit includes: (J-42220) UV lamp and UV safety goggles (J-41459) Refrigerant dye injector (J-41447) Fluorescent leak detection dye (box of 24, 1/4 ounce bottles) (J-43872) Refrigerant dye cleaner</p>	<p>Power supply: ● DC 12V (battery terminal)</p>  <p style="text-align: right;">ZHA200H</p>
<p>— (J-42220) Fluorescent dye leak detector</p>	<p>Power supply: ● DC 12V (battery terminal)</p> <p>For checking refrigerant leak when fluorescent dye is installed in A/C system. Includes: UV lamp and UV safety goggles</p>  <p style="text-align: right;">SHA438F</p>
<p>— (J-41447) HFC-134a (R-134a) Fluorescent leak detection dye (Box of 24, 1/4 ounce bottles)</p>	<p>Application: For HFC-134a (R-134a) PAG oil Container: 1/4 ounce (7.4cc) bottle (Includes self-adhesive dye identification labels for affixing to vehicle after charging system with dye.)</p>  <p style="text-align: right;">SHA439F</p>
<p>— (J-41459) HFC-134a (R-134a) Refrigerant dye injector Use with J-41447, 1/4 ounce bottle</p>	<p>For injecting 1/4 ounce of fluorescent leak detection dye into A/C system.</p>  <p style="text-align: right;">SHA440F</p>
<p>— (J-43872) Refrigerant dye cleaner</p>	<p>For cleaning dye spills.</p>  <p style="text-align: right;">SHA441F</p>

A  
B  
C  
D  
E  
F  
G  
H  
I  
K  
L  
M

ATC

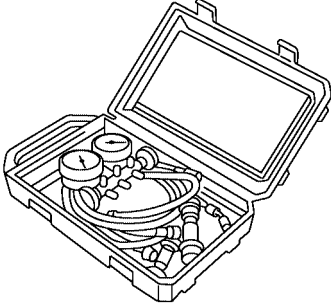
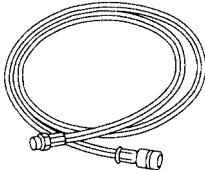
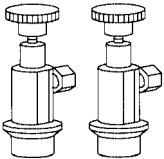
# PREPARATION

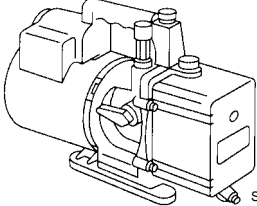
Tool number (Kent-Moore No.) Tool name	Description
<p>— (J-39183-C) Manifold gauge set (with hoses and couplers)</p>  <p style="text-align: right; font-size: small;">RJIA0196E</p>	<p>Identification:</p> <ul style="list-style-type: none"> <li>● The gauge face indicates R-134a. Fitting size-Thread size</li> <li>● 1/2"-16 ACME</li> </ul>
<p>Service hoses:</p> <ul style="list-style-type: none"> <li>● High side hose (J-39500-72B)</li> <li>● Low side hose (J-39500-72R)</li> <li>● Utility hose (J-39500-72Y)</li> </ul>  <p style="text-align: right; font-size: small;">S-NT201</p>	<p>Hose color:</p> <ul style="list-style-type: none"> <li>● Low side hose: Blue with black stripe</li> <li>● High side hose: Red with black stripe</li> <li>● Utility hose: Yellow with black stripe or green with black stripe</li> </ul> <p>Hose fitting to gauge:</p> <ul style="list-style-type: none"> <li>● 1/2"-16 ACME</li> </ul>
<p>Service couplers</p> <ul style="list-style-type: none"> <li>● High side coupler (J-39500-20A)</li> <li>● Low side coupler (J-39500-24A)</li> </ul>  <p style="text-align: right; font-size: small;">S-NT202</p>	<p>Hose fitting to service hose:</p> <ul style="list-style-type: none"> <li>● M14 x 1.5 fitting is optional or permanently attached.</li> </ul>
<p>— (J-39699) Refrigerant weight scale</p>  <p style="text-align: right; font-size: small;">S-NT200</p>	<p>For measuring of refrigerant Fitting size-Thread size</p> <ul style="list-style-type: none"> <li>● 1/2"-16 ACME</li> </ul>
<p>— (J-39649) Vacuum pump (Including the isolator valve)</p>  <p style="text-align: right; font-size: small;">S-NT203</p>	<p>Capacity:</p> <ul style="list-style-type: none"> <li>● Air displacement: 4 CFM</li> <li>● Micron rating: 20 microns</li> <li>● Oil capacity: 482 g (17 oz)</li> </ul> <p>Fitting size-Thread size</p> <ul style="list-style-type: none"> <li>● 1/2"-16 ACME</li> </ul>



# PREPARATION

## Commercial Service Tools

EJS00401

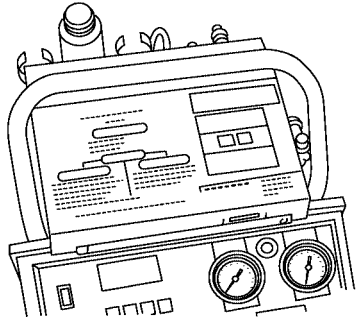
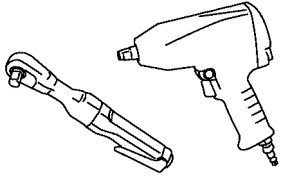
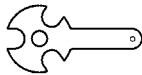
Tool name	Description
<p>(J-41810-NI) Refrigerant identifier equipment (R-134a)</p>  <p style="text-align: right;">RJIA0197E</p>	<p>For checking refrigerant purity and system contamination</p>
<p>Power tool</p>  <p style="text-align: right;">PBIC0190E</p>	<p>Loosening bolts and nuts</p>
<p>(J-44614) Clutch disc holding tool</p>  <p style="text-align: right;">WHA230</p>	<p>Clutch disc holding tool</p>

A  
B  
C  
D  
E  
F  
G  
H  
I

**ATC**

K  
L  
M

# REFRIGERATION SYSTEM

PPF:KA990

EJS0040J

## REFRIGERATION SYSTEM

### Components FRONT REFRIGERATION SYSTEM

SEC. 270 • 271

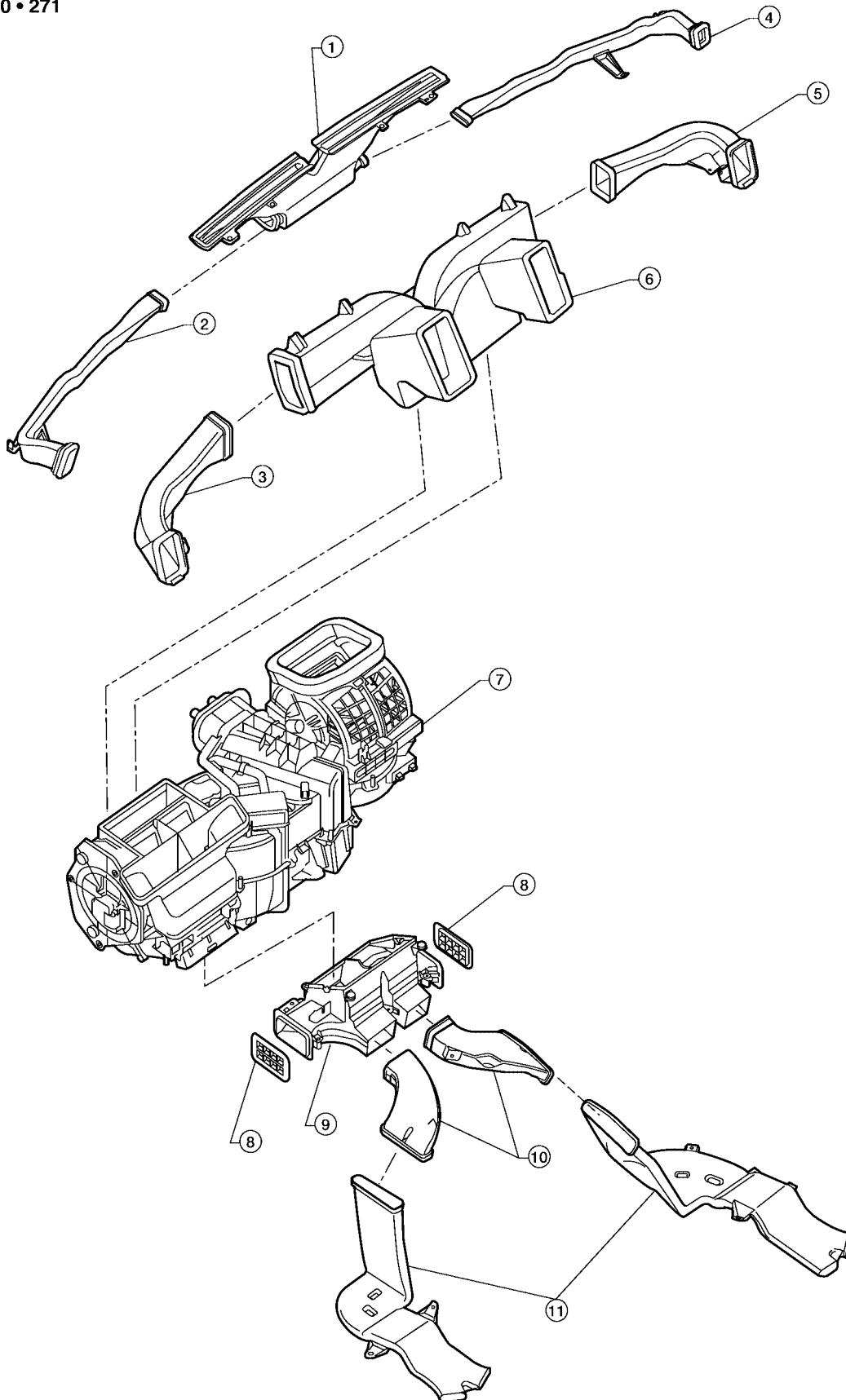

WJIA1260E

# REFRIGERATION SYSTEM

- |   |                                 |                           |
|---|---------------------------------|---------------------------|
| 1. Defroster nozzle                       | 2. LH side demister duct        | 3. LH ventilator duct     |
| 4. RH side demister duct                  | 5. RH ventilator duct           | 6. Center ventilator duct |
| 7. Front heater and cooling unit assembly | 8. Floor connector duct grilles | 9. Floor connector duct   |
| 10. Front floor ducts                     | 11. Rear floor ducts            |                           |

## REAR REFRIGERATION SYSTEM

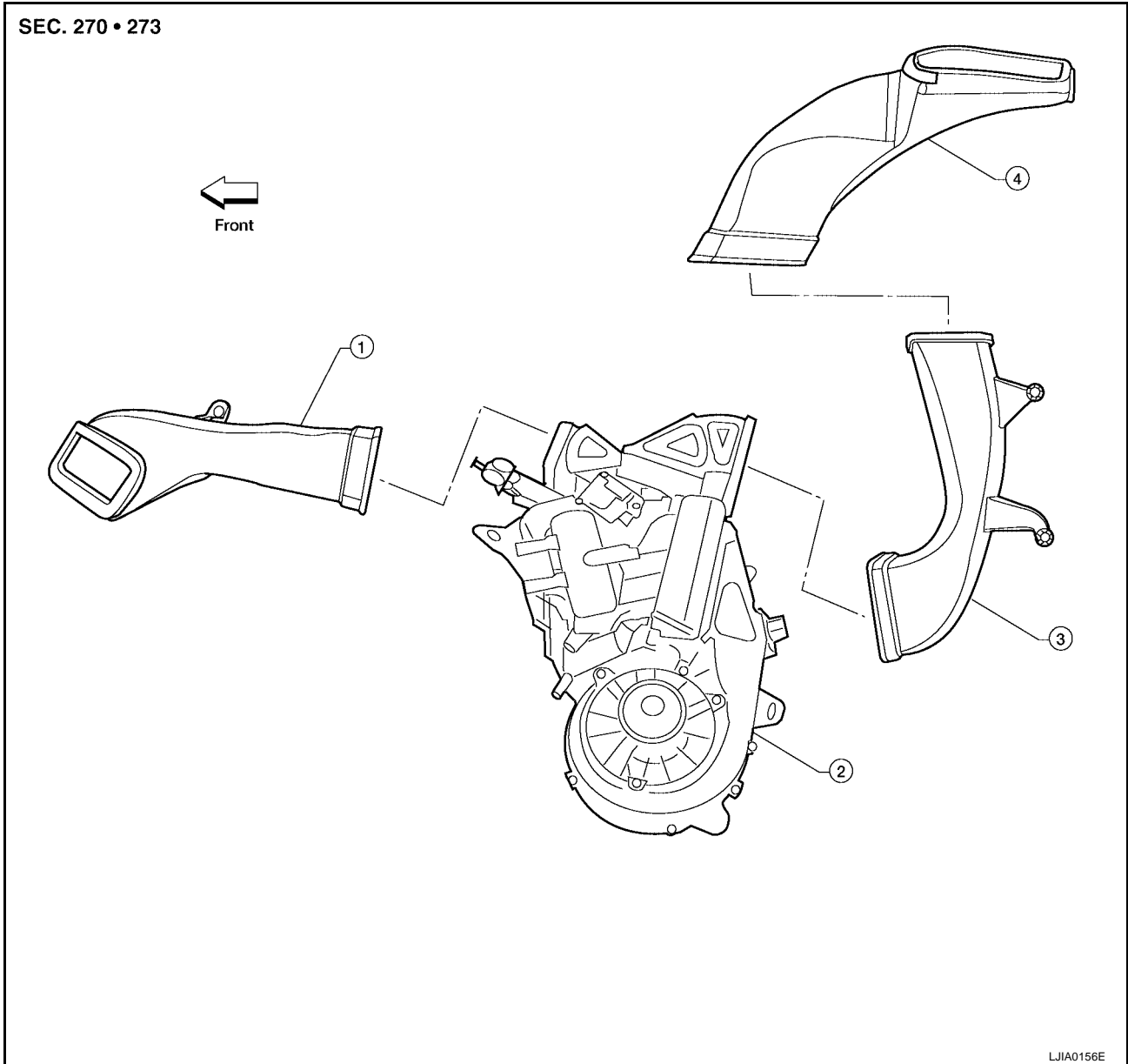

- |                             |  |                             |
|-----------------------------|--|-----------------------------|
| 1. Side rear floor duct     | 2. Rear heater and cooling unit assembly | 3. Rear lower overhead duct |
| 4. Rear upper overhead duct |  |                             |

A  
B  
C  
D  
E  
F  
G  
H  
I  
K  
L  
M

ATC

# REFRIGERATION SYSTEM

## Refrigerant Cycle

EJS0040K

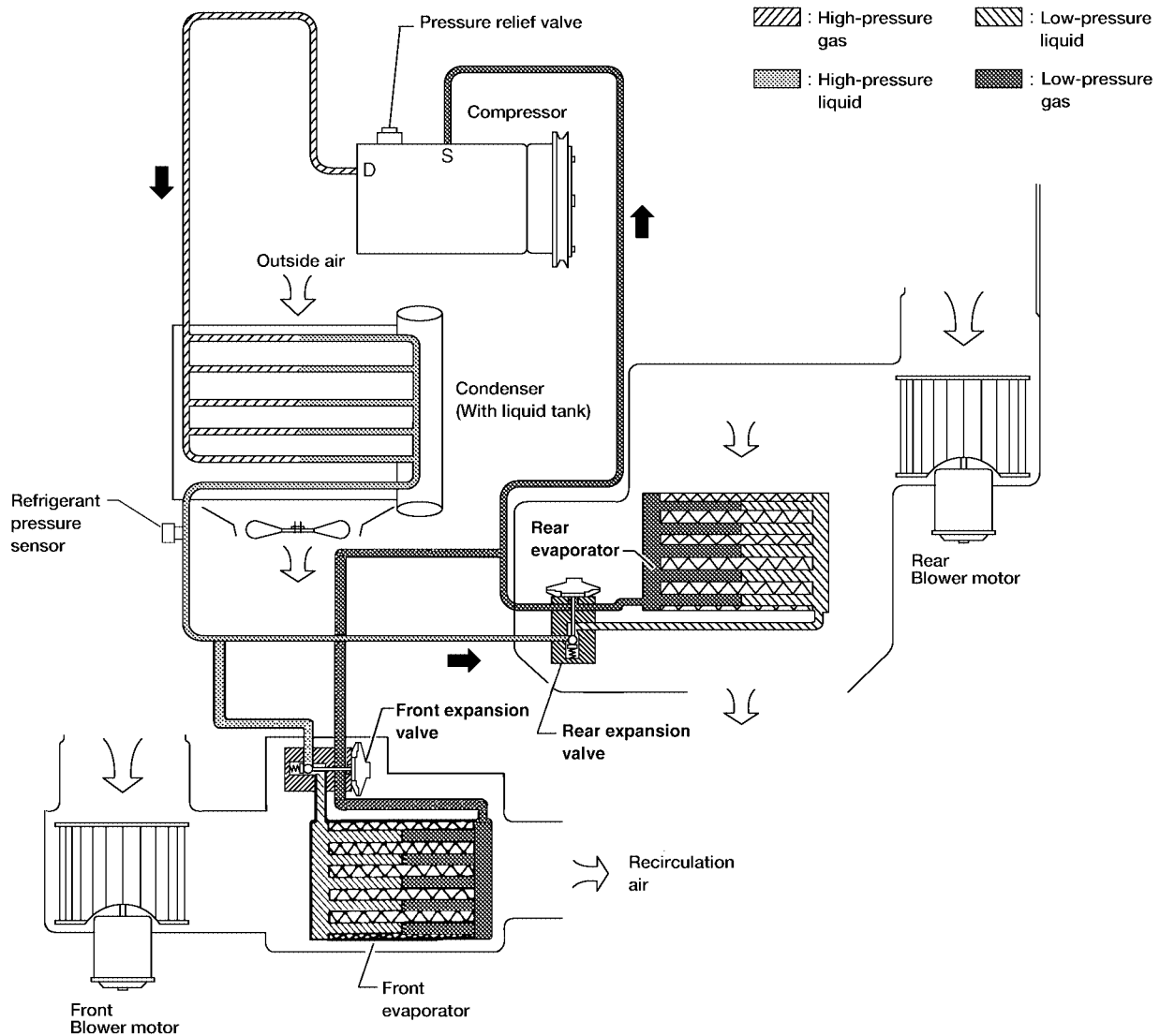

WJIA1342E

### REFRIGERANT FLOW

The refrigerant flows in the standard pattern, that is, through the compressor, the condenser with liquid tank, through the front and rear evaporators, and back to the compressor. The refrigerant evaporation through the evaporator coils are controlled by front and rear externally equalized expansion valves, located inside the front and rear evaporator cases.

### FREEZE PROTECTION

The compressor cycles on and off to maintain the evaporator temperature within a specified range. When the evaporator coil temperature falls below a specified point, the intake sensor interrupts the compressor operation. When the evaporator coil temperature rises above the specification, the intake sensor allows compressor operation.

# REFRIGERATION SYSTEM

## Refrigerant System Protection REFRIGERANT PRESSURE SENSOR

EJS0040L

The refrigerant system is protected against excessively high- or low-pressures by the refrigerant pressure sensor, located on the condenser. If the system pressure rises above or falls below the specifications, the refrigerant pressure sensor detects the pressure inside the refrigerant line and sends a voltage signal to the ECM. The ECM de-energizes the A/C relay to disengage the magnetic compressor clutch when pressure on the high pressure side detected by refrigerant pressure sensor is over about 2,746 kPa (28 kg/cm<sup>2</sup> , 398 psi), or below about 120 kPa (1.22 kg/cm<sup>2</sup> , 17.4 psi).

## PRESSURE RELIEF VALVE

The refrigerant system is also protected by a pressure relief valve, located in the rear head of the compressor. When the pressure of refrigerant in the system increases to an abnormal level [more than 2,990 kPa (30.5 kg/cm<sup>2</sup> , 433.6 psi)], the release port on the pressure relief valve automatically opens and releases refrigerant into the atmosphere.

A  
B  
C  
D  
E  
F  
G  
H  
I  
K  
L  
M

ATC

**OIL****Maintenance of Oil Quantity in Compressor**

EJS0040M

The oil in the compressor circulates through the system with the refrigerant. Add oil to compressor when replacing any component or after a large refrigerant leakage has occurred. It is important to maintain the specified amount.

If oil quantity is not maintained properly, the following malfunctions may result:

- Lack of oil: May lead to a seized compressor
- Excessive oil: Inadequate cooling (thermal exchange interference)

**OIL**

Oil name: NISSAN A/C System Oil Type S or equivalent

**CHECKING AND ADJUSTING****CAUTION:**

**If excessive oil leakage is noted, do not perform the oil return operation.**

Start the engine and set the following conditions:

**Test Conditions**

- **Engine speed: idling to 1,200 rpm**
- **A/C switch: ON**
- **Blower fan speed: HIGH**
- **Temperature control: optional [set so intake air temperature is 25° to 30° C (77° to 86°F)]**
- **Intake position: RECIRCULATION mode**
- **Perform oil return operation for about ten minutes**

Adjust the oil quantity according to the following table.

**Oil Adjusting Procedure for Components Replacement Except Compressor**

After replacing any of the following major components, add the correct amount of oil to the system.

**Amount of Oil to be Added**

Part replaced	Oil to be added to system	Remarks
	Amount of oil m ℓ (US fl oz, Imp fl oz)	
Front evaporator	75 (2.5, 2.6)	—
Rear evaporator	75 (2.5, 2.6)	—
Condenser	75 (2.5, 2.6)	—
Liquid tank	5 (0.2, 0.2)	Add if compressor is not replaced.
In case of refrigerant leak	30 (1.0, 1.1)	Large leak
	—	Small leak *1

\*1: If refrigerant leak is small, no addition of oil is needed.

# OIL

## Oil Adjustment Procedure for Compressor Replacement

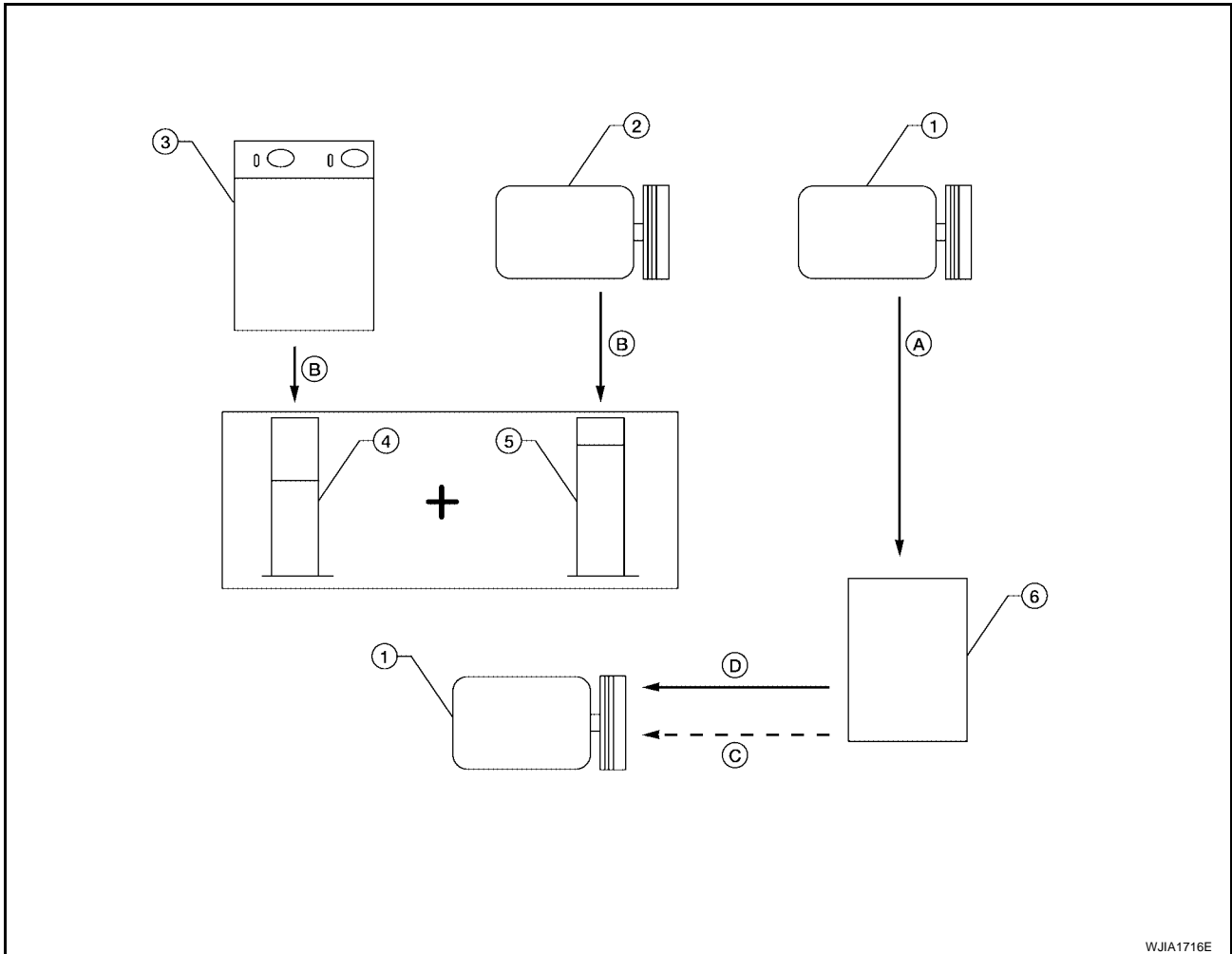

- |   |                                   |   |
|---|-----------------------------------|---|
| 1. New compressor   | 2. Old compressor                 | 3. Recovery/recycling equipment   |
| 4. Measuring cup X  | 5. Measuring cup Y                | 6. New oil  |
| A. Drain oil from the new compressor into clean container               | B. Record amount of oil recovered | C. Add an additional 5 mℓ (0.2 US fl oz, 0.2 Imp fl oz) of new oil when replacing liquid tank |
| D. Install new oil equal to recorded amounts in measuring cups X plus Y |                                   |   |

1. Before connecting recovery/recycling equipment to vehicle, check recovery/recycling equipment gauges. No refrigerant pressure should be displayed. If NG, recover refrigerant from equipment lines.
2. Connect recovery/recycling equipment to vehicle. Confirm refrigerant purity in supply tank using recovery/recycling equipment and refrigerant identifier. If NG, refer to [ATC-5, "Contaminated Refrigerant"](#).
3. Confirm refrigerant purity in vehicle A/C system using recovery/recycling equipment and refrigerant identifier. If NG, refer to [ATC-5, "Contaminated Refrigerant"](#).
4. Discharge refrigerant into the refrigerant recovery/recycling equipment. Measure oil discharged into the recovery/recycling equipment.
5. Drain the oil from the "old" (removed) compressor into a graduated container and recover the amount of oil drained.
6. Drain the oil from the "new" compressor into a separate, clean container.
7. Measure an amount of new oil installed equal to amount drained from "old" compressor. Add this oil to "new" compressor through the suction port opening.
8. Measure an amount of new oil equal to the amount recovered during discharging. Add this oil to "new" compressor through the suction port opening.
9. If the liquid tank also needs to be replaced, add an additional 5 mℓ (0.2 US fl oz, 0.2 Imp fl oz) of oil at this time.

## OIL

---

**Do not add this 5 mℓ (0.2 US fl oz, 0.2 Imp fl oz) of oil if only replacing the compressor.**



# AIR CONDITIONER CONTROL

## AIR CONDITIONER CONTROL

PFP:27500

### Description

EJS0040N

The front air control provides automatic regulation of the vehicle's interior temperature. The system is based on the driver's and passenger's selected "set temperature", regardless of the outside temperature changes. This is done by utilizing a microcomputer, also referred to as the front air control, which receives input signals from the following six sensors:

- Ambient sensor
- In-vehicle sensor
- Intake sensor
- Optical sensor (providing one input for driver and one input for passenger side)
- PBR (Position Balanced Resistor)
- Vehicle speed sensor

The front air control uses these signals (including the set temperature) to automatically control:

- Outlet air volume
- Air temperature
- Air distribution

The front air control also provides separate regulation of the vehicle's interior temperature for the rear passenger area. The system is based on the temperature and rear blower settings selected from rear control switches located on the front air control, or from the temperature and rear blower settings selected from rear control switches on the rear air control, when the front air control switches are set to the rear position.

The front air control is used to select:

- Outlet air volume
- Air temperature/distribution

### Operation

EJS00400

#### AIR MIX DOORS CONTROL

The air mix doors are automatically controlled so that in-vehicle temperature is maintained at a predetermined value by the temperature setting, ambient temperature, in-vehicle temperature and amount of sunload.

ATC

#### BLOWER SPEED CONTROL

Blower speed is automatically controlled by the temperature setting, ambient temperature, in-vehicle temperature, intake temperature, amount of sunload and air mix door position.

When AUTO switch is pressed, the blower motor starts to gradually increase air flow volume (if required).

When engine coolant temperature is low, the blower motor operation is delayed to prevent cool air from flowing.

#### INTAKE DOOR CONTROL

The intake door is automatically controlled by the temperature setting, ambient temperature, in-vehicle temperature, intake temperature, amount of sunload and the ON-OFF operation of the compressor.

#### MODE DOOR CONTROL

The mode door is automatically controlled by the temperature setting, ambient temperature, in-vehicle temperature, intake temperature and amount of sunload.

#### DEFROSTER DOOR CONTROL

The defroster door is controlled by: Turning the defroster dial to front defroster.

# AIR CONDITIONER CONTROL

## MAGNET CLUTCH CONTROL

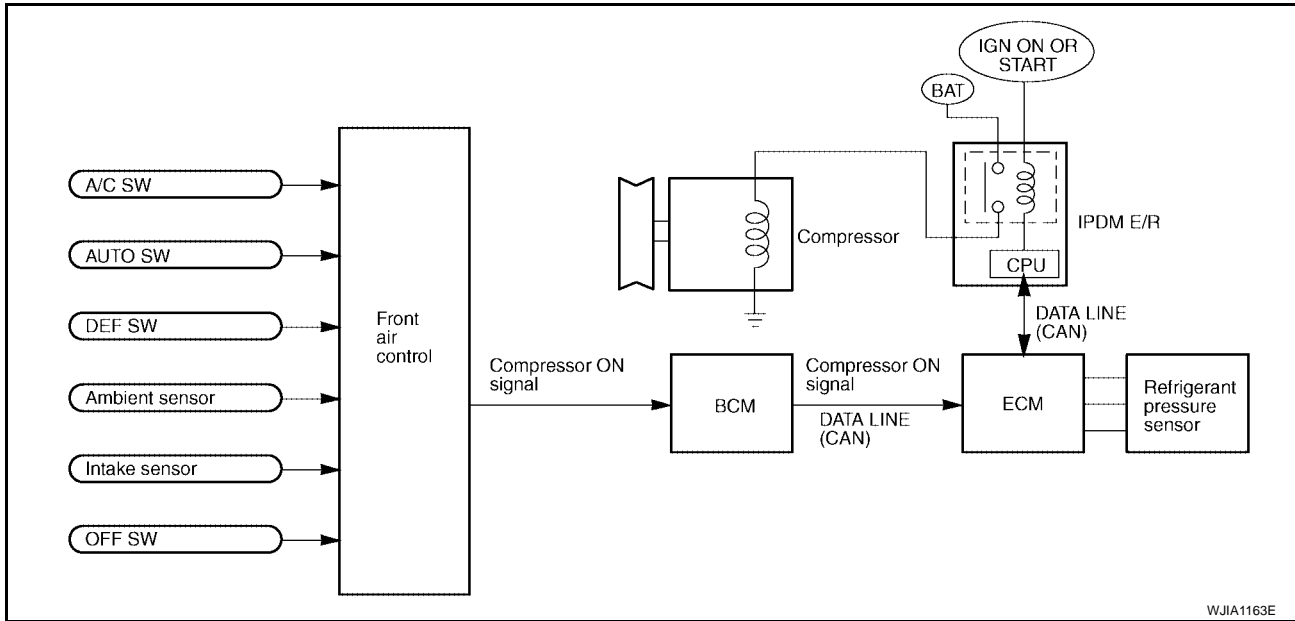

When A/C switch or DEF switch is pressed, front air control inputs compressor ON signal to BCM.

BCM sends compressor ON signal to ECM, via CAN communication line.

ECM judges whether compressor can be turned ON, based on each sensor status (refrigerant pressure sensor signal, throttle angle sensor, etc.). If it judges compressor can be turned ON, it sends compressor ON signal to IPDM E/R, via CAN communication line.

Upon receipt of compressor ON signal from ECM, IPDM E/R turns air conditioner relay ON to operate compressor.

### SELF-DIAGNOSTIC SYSTEM

The self-diagnostic system is built into the front air control to quickly locate the cause of symptoms. Refer to [ATC-51, "A/C System Self-diagnosis Function"](#).

# AIR CONDITIONER CONTROL

## Description of Control System

EJS0040P

The control system consists of input sensors, switches, the front air control (microcomputer) and outputs. The relationship of these components is shown in the figure below:

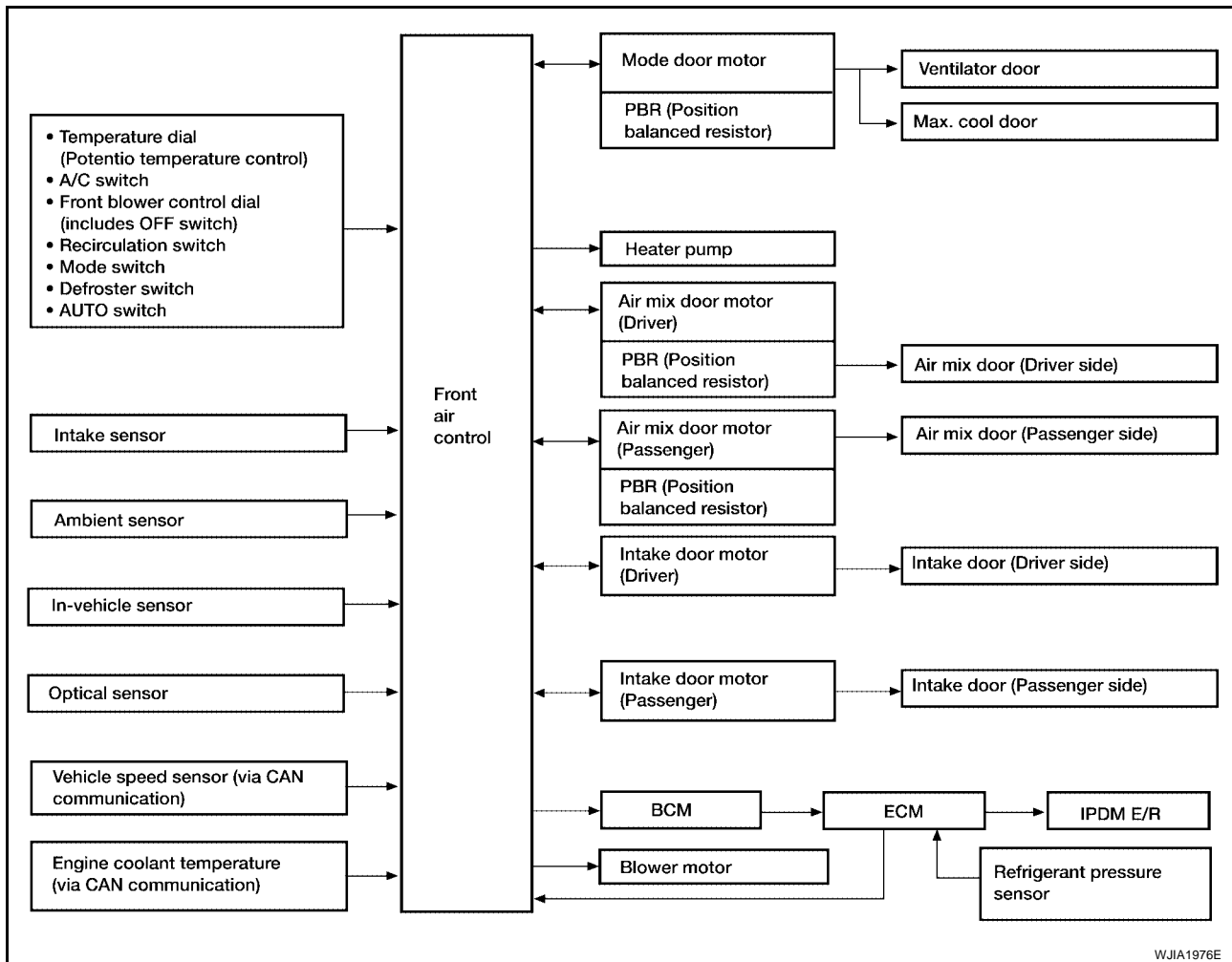

WJIA1976E

## Control Operation

EJS0040Q

### Front air control

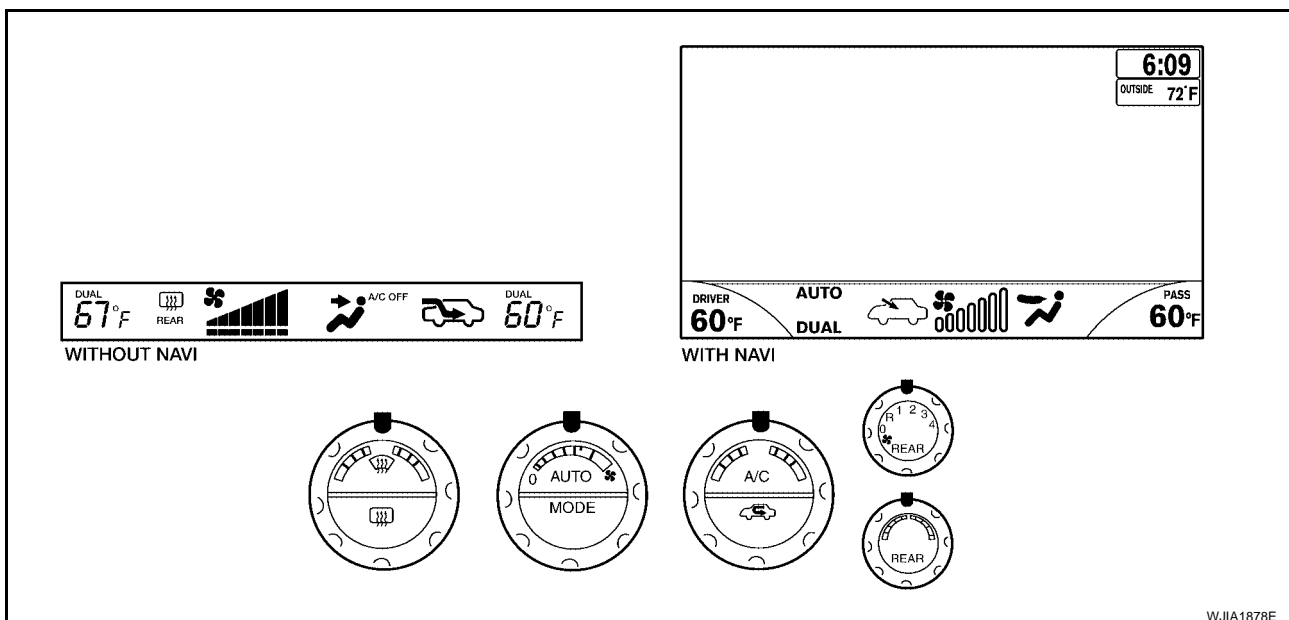

WJIA1878E

# AIR CONDITIONER CONTROL

---

## DISPLAY SCREEN

Displays the operational status of the system.

## AUTO SWITCH

- The compressor, intake door, air mix doors, outlet doors and blower speed are automatically controlled so that the in-vehicle temperature will reach, and be maintained at the set temperature selected by the operator.
- When pressing AUTO switch, air inlet, air outlet, blower speed, and discharge air temperature are automatically controlled.

## TEMPERATURE CONTROL DIAL (TEMPERATURE CONTROL) (DRIVER SIDE)

Increases or decreases the set temperature.

## TEMPERATURE CONTROL DIAL (TEMPERATURE CONTROL) (PASSENGER SIDE)

Increases or decreases the set temperature.

## TEMPERATURE CONTROL DIAL (TEMPERATURE AND MODE CONTROL) (REAR)

Increases or decreases the set temperature. The mode also changes from foot at full hot setting, to foot/vent mid-range (warm) setting, and then to vent on full cold setting.

## RECIRCULATION ( ) SWITCH

- When REC switch is ON, REC switch indicator turns ON, and air inlet is set to REC.
- When REC switch is turned OFF, or when compressor is turned from ON to OFF, REC switch is automatically turned OFF. REC mode can be re-entered by pressing REC switch again.
- REC switch is not operated when DEF switch is turned ON, or at the D/F position.

## DEFROSTER ( ) SWITCH

Positions the air outlet doors to the defrost position. Also positions the intake doors to the outside air position.

## REAR WINDOW DEFOGGER SWITCH

When switch is ON, rear window is defogged.

## OFF SWITCH

The compressor and blower are OFF, the intake doors are set to the outside air position, and the air outlet doors are set to the foot (75% foot and 25% defrost) position.

## A/C SWITCH

The compressor is ON or OFF.

(Pressing the A/C switch when the AUTO switch is ON will turn off the A/C switch and compressor.)

## MODE SWITCH (FRONT)

Controls the air discharge outlets.

## FRONT BLOWER CONTROL DIAL

Manually control the blower speed. Seven speeds are available for manual control (as shown on the display screen on all models with Navi).

## MODE SWITCH (REAR)

Controls the air/temperature at discharge outlets.

# AIR CONDITIONER CONTROL

## Rear Air Control

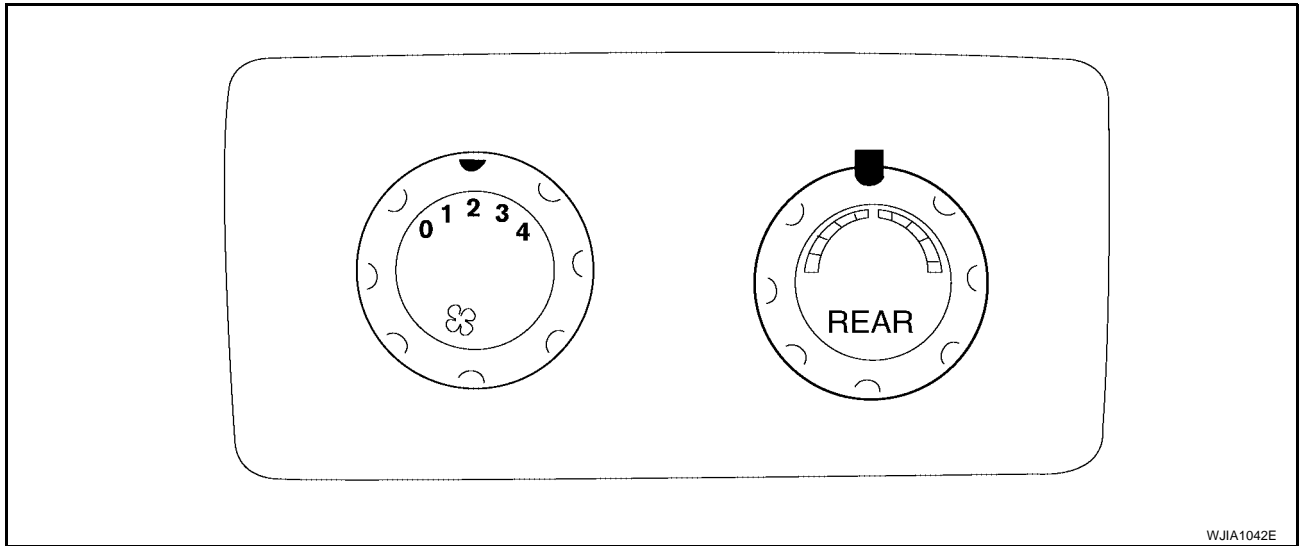

### TEMPERATURE CONTROL DIAL (TEMPERATURE AND MODE CONTROL)

The temperature increases or decreases the set temperature. The mode also changes from foot at full hot setting, to foot/vent at mid-range (warm) setting, and then to vent at full cold setting.

### REAR BLOWER CONTROL DIAL

When the rear blower switch (front) is in the OFF position, the rear blower motor cannot operate. When the rear blower switch (front) is in the REAR position, it allows the rear blower switch (rear) to control the rear blower motor speed. In any other position (1-4), the rear blower switch (front) controls the rear blower motor speed regardless of the rear blower switch (rear) position.

A

B

C

D

E

F

G

H

I

ATC

K

L

M

# AIR CONDITIONER CONTROL

## Discharge Air Flow FRONT

EJS0040R

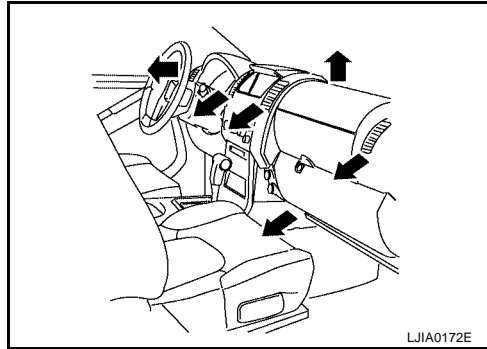

Mode door position	Air outlet/distribution		
	Vent	Foot	Defroster
	100%	0%	—
	60%	40%	—
	18%	64%	18%
	14%	64%	33%
	—	13%	83%

Airflow always present at driver and passenger side demisters

## REAR

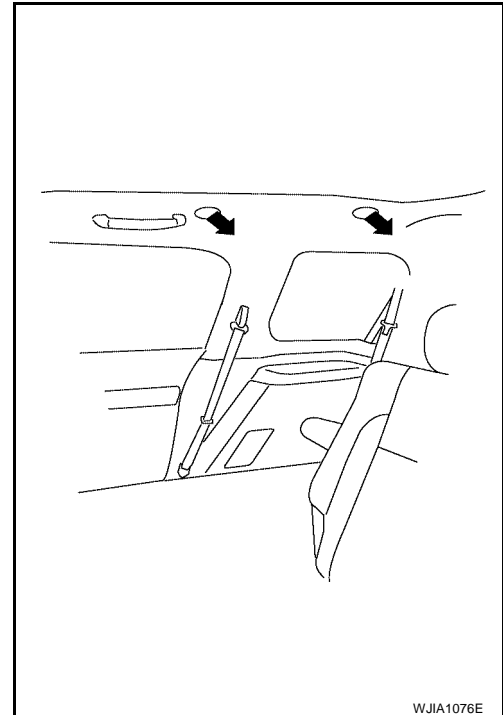

Mode door position	Air outlet/distribution	
	Roof Vent	Foot
Cool	80%	20%
Mid	80%	20%
Hot	80%	20%

Airflow distribution is always constant

# AIR CONDITIONER CONTROL

## System Description (Front) SWITCHES AND THEIR CONTROL FUNCTION

EJS0040S

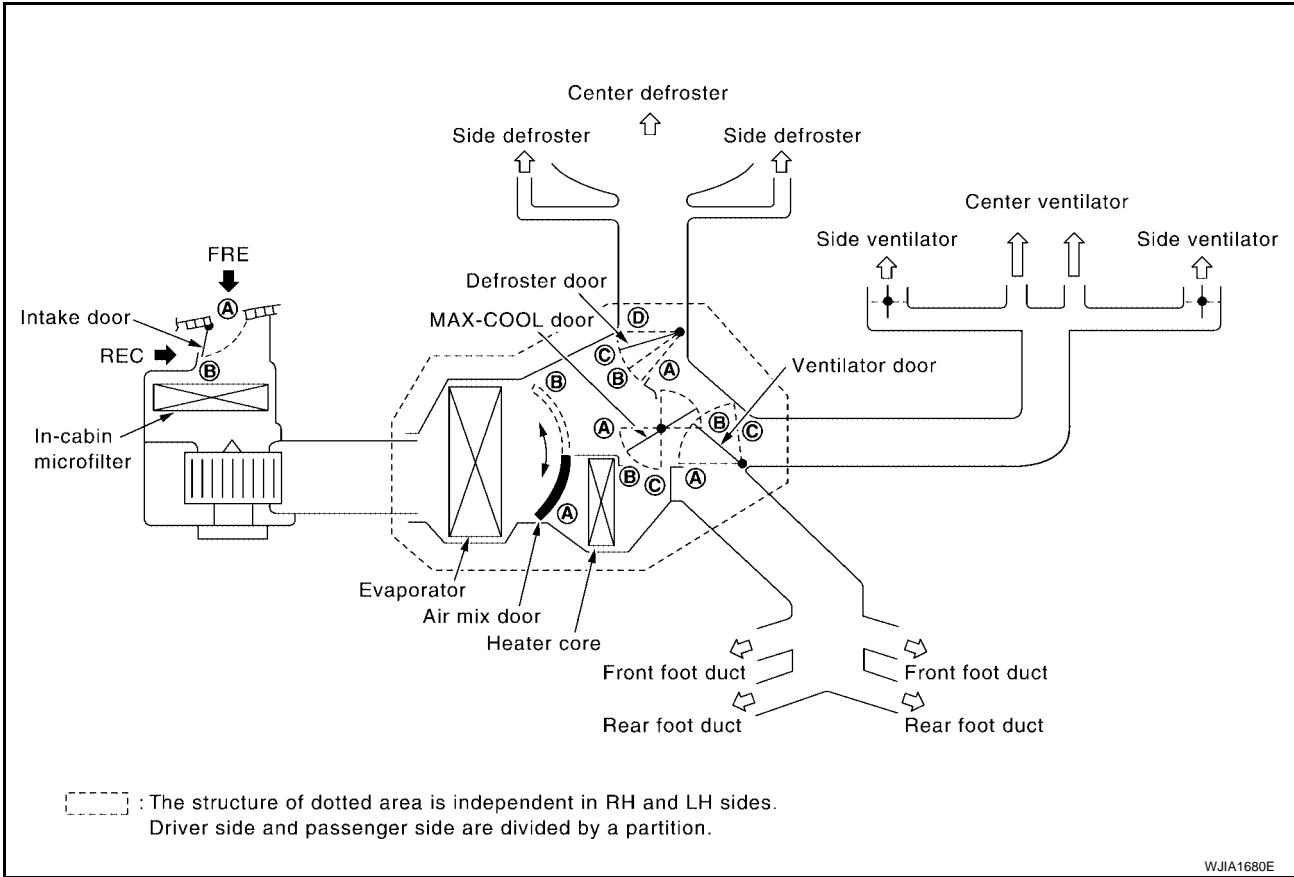

A  
B  
C  
D  
E  
F  
G  
H  
I

ATC

K  
L  
M

Position or switch	MODE SW				DEF SW		REC SW		Temperature control dial			OFF SW	
	VENT	B/L	FOOT	D/F	ON	OFF	ON	OFF					
					FRONT 								COLD
Ventilator door	(A)	(B)	(C)	(C)	(C)	---	---	---	---	---	---	(C)	
MAX-COOL door	(A)	(B)	(B)	(B)	(C)		---	---	---	---	---	---	(B)
Defroster door	(D)	(D)	(D <sub>or</sub> C)	(B)	(A)		---	---	---	---	---	---	(C)
Intake door	---				(B)		---	(A)	(B)	---	---	---	(B)
Air mix door	---				---		---	---	---	(A)	AUTO	(B)	---

WJIA1237E

# AIR CONDITIONER CONTROL

## System Description (Rear) SWITCHES AND THEIR CONTROL FUNCTION

EJS0040T

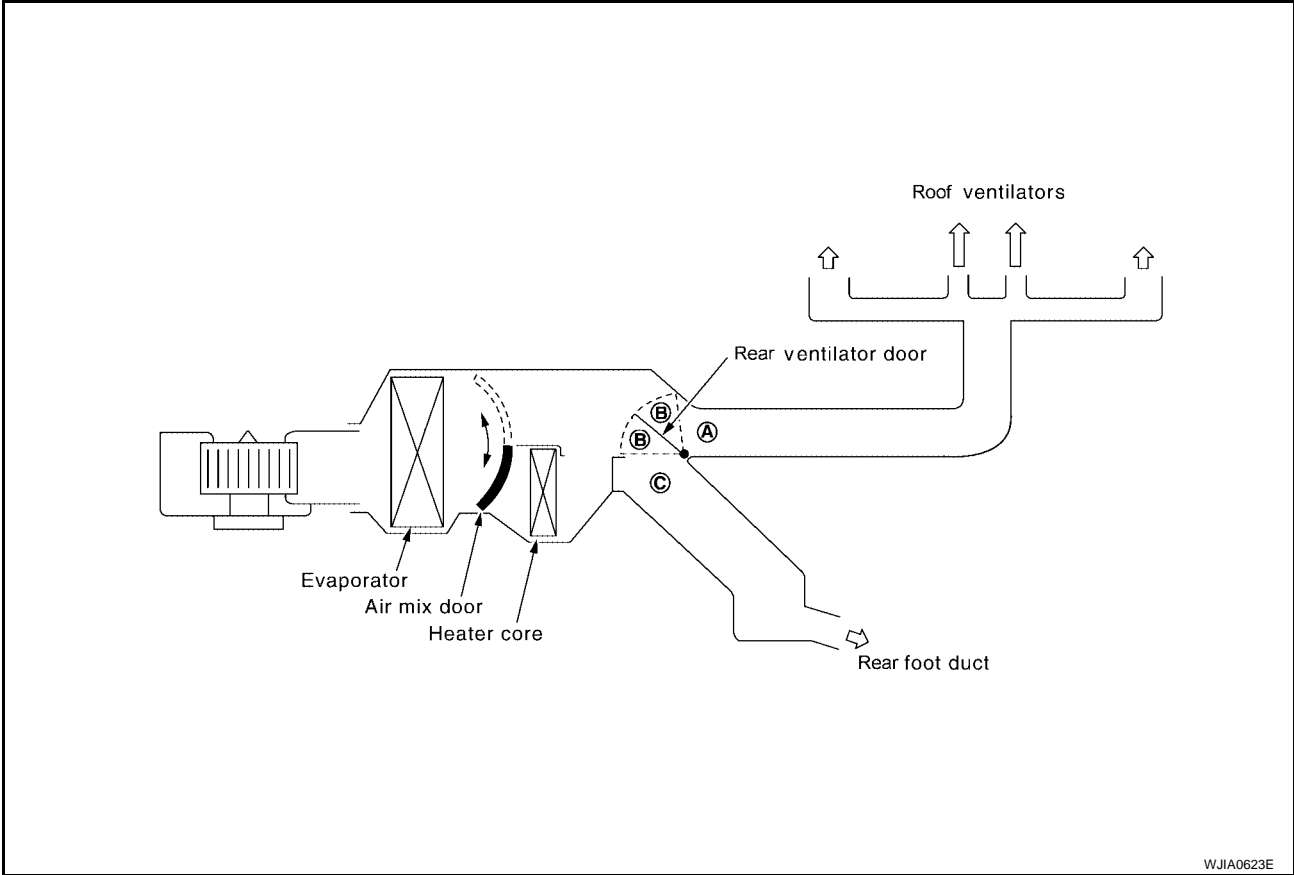

WJIA0623E

	Temp Control Dial			OFF SW
Door	COLD	~	HOT	OFF
Mode door	Fixed Position			
Air mix door	(A)		(B)	—

WJIA1685E



# AIR CONDITIONER CONTROL

---

## CAN Communication System Description

EJS0040U

Refer to [LAN-25, "CAN COMMUNICATION"](#) .

A

B

C

D

E

F

G

H

I

**ATC**

K

L

M

# TROUBLE DIAGNOSIS

## TROUBLE DIAGNOSIS

PF0:00004

### CONSULT-II Function (BCM)

EJS0040V

CONSULT-II can display each diagnostic item using the diagnostic test modes shown following.

BCM diagnostic test item	Diagnostic mode	Description
Inspection by part	WORK SUPPORT	Supports inspections and adjustments. Commands are transmitted to the BCM for setting the status suitable for required operation, input/output signals are received from the BCM and received data is displayed.
	DATA MONITOR	Displays BCM input/output data in real time.
	ACTIVE TEST	Operation of electrical loads can be checked by sending drive signal to them.
	SELF-DIAG RESULTS	Displays BCM self-diagnosis results.
	CAN DIAG SUPPORT MNTR	The result of transmit/receive diagnosis of CAN communication can be read.
	ECU PART NUMBER	BCM part number can be read.
	CONFIGURATION	Performs BCM configuration read/write functions.

### CONSULT-II BASIC OPERATION

#### CAUTION:

If CONSULT-II is used with no connection of CONSULT-II CONVERTER, malfunctions might be detected in self-diagnosis depending on control unit which carries out CAN communication.

1. With the ignition switch OFF, connect CONSULT-II and CONSULT-II CONVERTER to the data link connector, and turn the ignition switch ON.

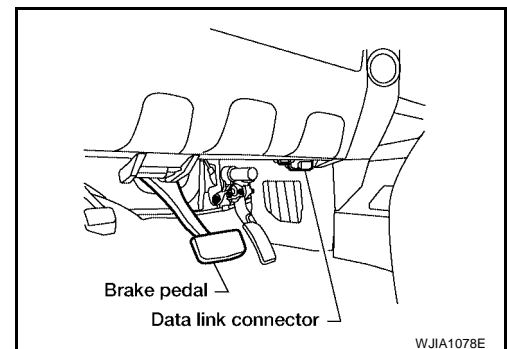

2. Touch "START (NISSAN BASED VHCL)".

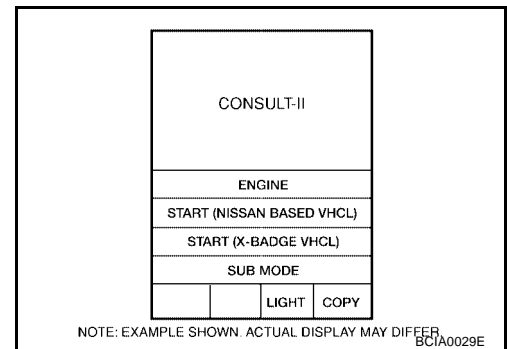

3. Touch "BCM" on "SELECT SYSTEM" screen.  
If "BCM" is not indicated, go to [GI-40, "CONSULT-II Data Link Connector \(DLC\) Circuit"](#).

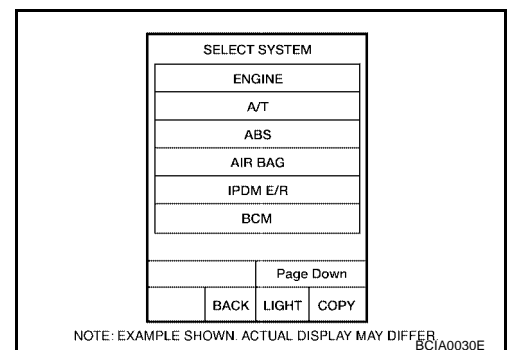

# TROUBLE DIAGNOSIS

## DATA MONITOR

### Operation Procedure

1. Touch "AIR CONDITIONER" on "SELECT TEST ITEM" screen.

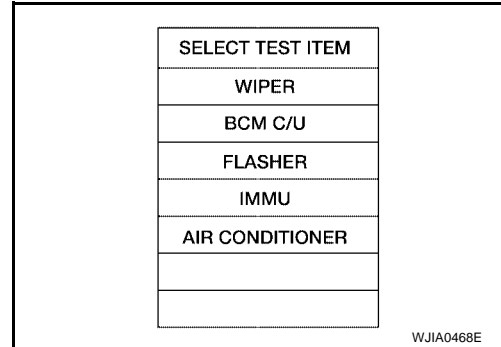

2. Touch "DATA MONITOR" on "SELECT DIAG MODE" screen.

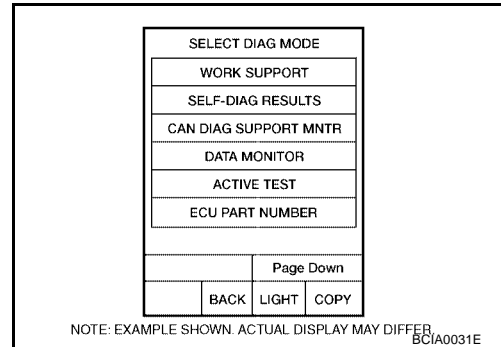

3. Touch either "ALL SIGNALS" or "SELECTION FROM MENU" on "DATA MONITOR" screen.

ALL SIGNALS	Monitors all the items.
SELECTION FROM MENU	Selects and monitors the individual item selected.

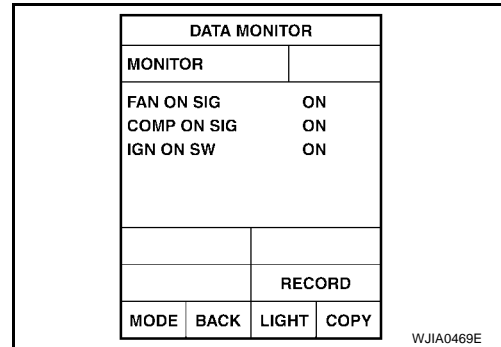

4. When "SELECTION FROM MENU" is selected, touch items to be monitored. When "ALL SIGNALS" is selected, all the items will be monitored.
5. Touch "START".
6. Touch "RECORD" while monitoring, then the status of the monitored item can be recorded. To stop recording, touch "STOP".

### Display Item List

Monitor item name "OPERATION OR UNIT"	Contents
IGN ON SW "ON/OFF"	Displays "IGN Position (ON)/OFF, ACC Position (OFF)" status as judged from ignition switch signal.
COMP ON SIG "ON/OFF"	Displays "COMP (ON)/COMP (OFF)" status as judged from air conditioner switch signal.
FAN ON SIG "ON/OFF"	Displays "FAN (ON)/FAN (OFF)" status as judged from blower motor switch signal.

A  
B  
C  
D  
E  
F  
G  
H  
I  
K  
L  
M

ATC

# TROUBLE DIAGNOSIS

EJS0040W

## How to Perform Trouble Diagnosis for Quick and Accurate Repair WORK FLOW

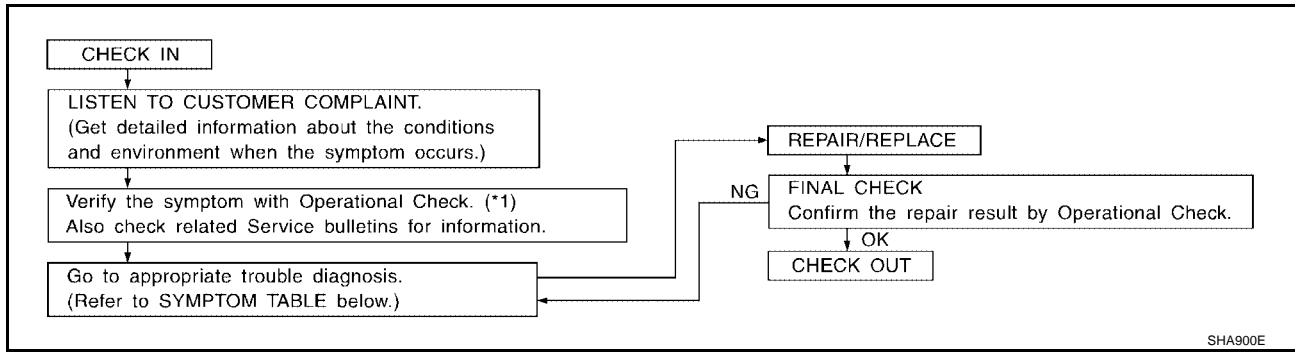

SHA900E

\*1 [ATC-53. "Operational Check \(Front\)"](#)  
or [ATC-55. "Operational Check  
\(Rear\)"](#) .

## SYMPTOM TABLE

Symptom	Reference Page	
A/C system does not come on.	Go to Trouble Diagnosis Procedure for A/C System.	<a href="#">ATC-56</a>
A/C system display is malfunctioning.	Go to Navigation System.	<a href="#">AV-78</a>
A/C system cannot be controlled.	Go to Self-diagnosis Function.	<a href="#">ATC-51</a>
Air outlet does not change.	Go to Trouble Diagnosis Procedure for Mode Door Motor.	<a href="#">ATC-59</a>
Mode door motor is malfunctioning.		
Discharge air temperature does not change.	Go to Trouble Diagnosis Procedure for Air Mix Door Motor.	<a href="#">ATC-63</a>
Air mix door motor is malfunctioning.		
Intake door does not change.	Go to Trouble Diagnosis Procedure for Intake Door Motor.	<a href="#">ATC-72</a>
Intake door motor is malfunctioning.		
Front blower motor operation is malfunctioning.	Go to Trouble Diagnosis Procedure for Front Blower Motor.	<a href="#">ATC-75</a>
Rear blower motor operation is malfunctioning.	Go to Trouble Diagnosis Procedure for Rear Blower Motor.	<a href="#">ATC-82</a>
Rear discharge air temperature and/or air outlet does not change.	Go to Trouble Diagnosis Procedure for Rear Air Control circuit.	<a href="#">ATC-93</a>
Magnet clutch does not engage.	Go to Trouble Diagnosis Procedure for Magnet Clutch.	<a href="#">ATC-96</a>
Insufficient cooling	Go to Trouble Diagnosis Procedure for Insufficient Cooling.	<a href="#">ATC-102</a>
Insufficient heating	Go to Trouble Diagnosis Procedure for Insufficient Heating.	<a href="#">ATC-109</a>
Noise	Go to Trouble Diagnosis Procedure for Noise.	<a href="#">ATC-113</a>
Self-diagnosis cannot be performed.	Go to Trouble Diagnosis Procedure for Self-diagnosis.	<a href="#">ATC-115</a>
Memory function does not operate.	Go to Trouble Diagnosis Procedure for Memory Function.	<a href="#">ATC-116</a>

# TROUBLE DIAGNOSIS

## Component Parts and Harness Connector Location ENGINE COMPARTMENT

EJS0040X

A  
B  
C  
D  
E  
F  
G  
H  
I  
K  
L  
M

ATC

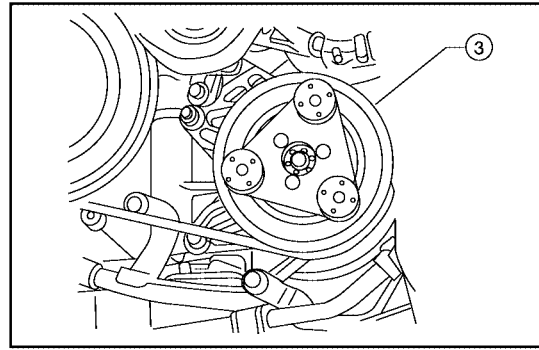
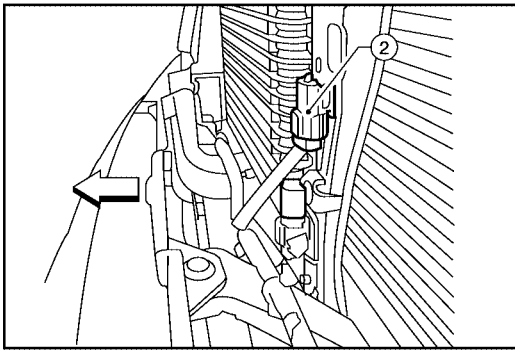
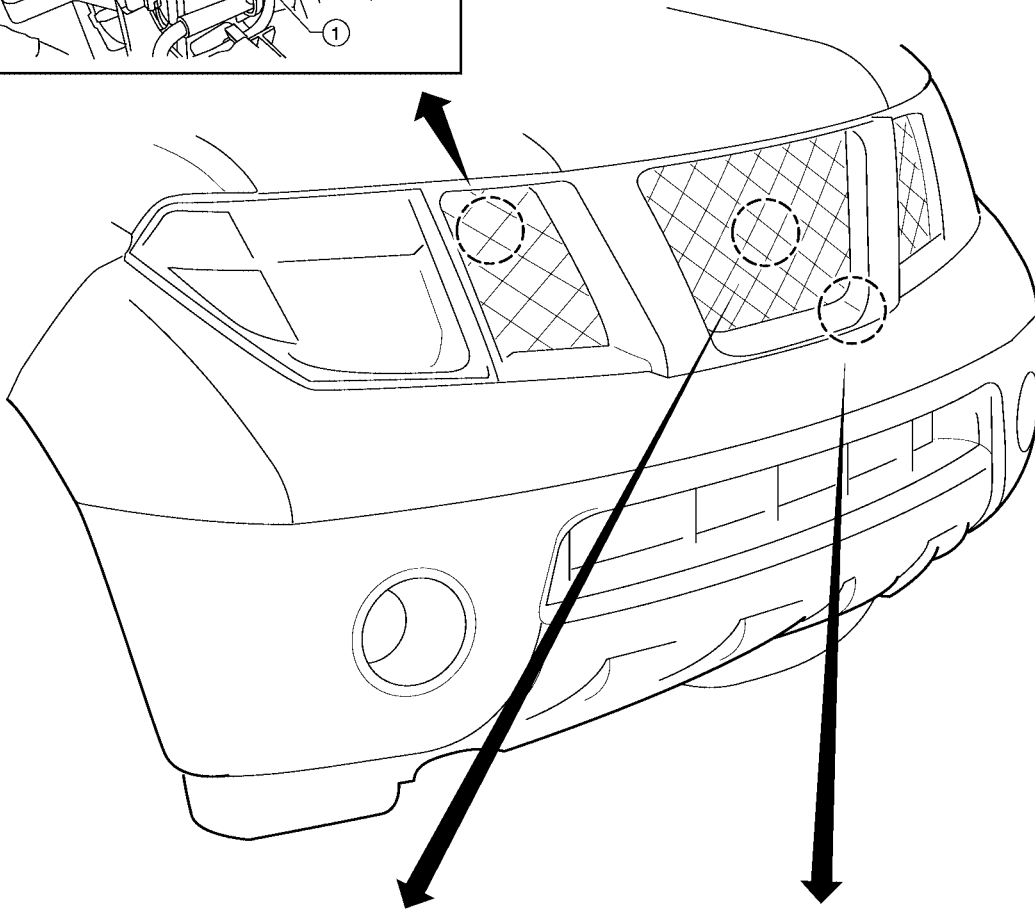
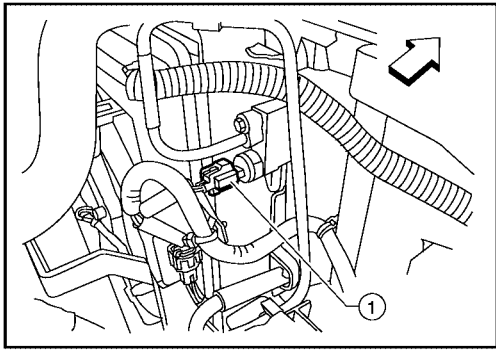

WJIA1982E

1. Refrigerant pressure sensor E48  
(View with battery removed)  
⇐: Front

2. Ambient sensor 1 E1

3. Compressor F3

# TROUBLE DIAGNOSIS

## FRONT PASSENGER COMPARTMENT

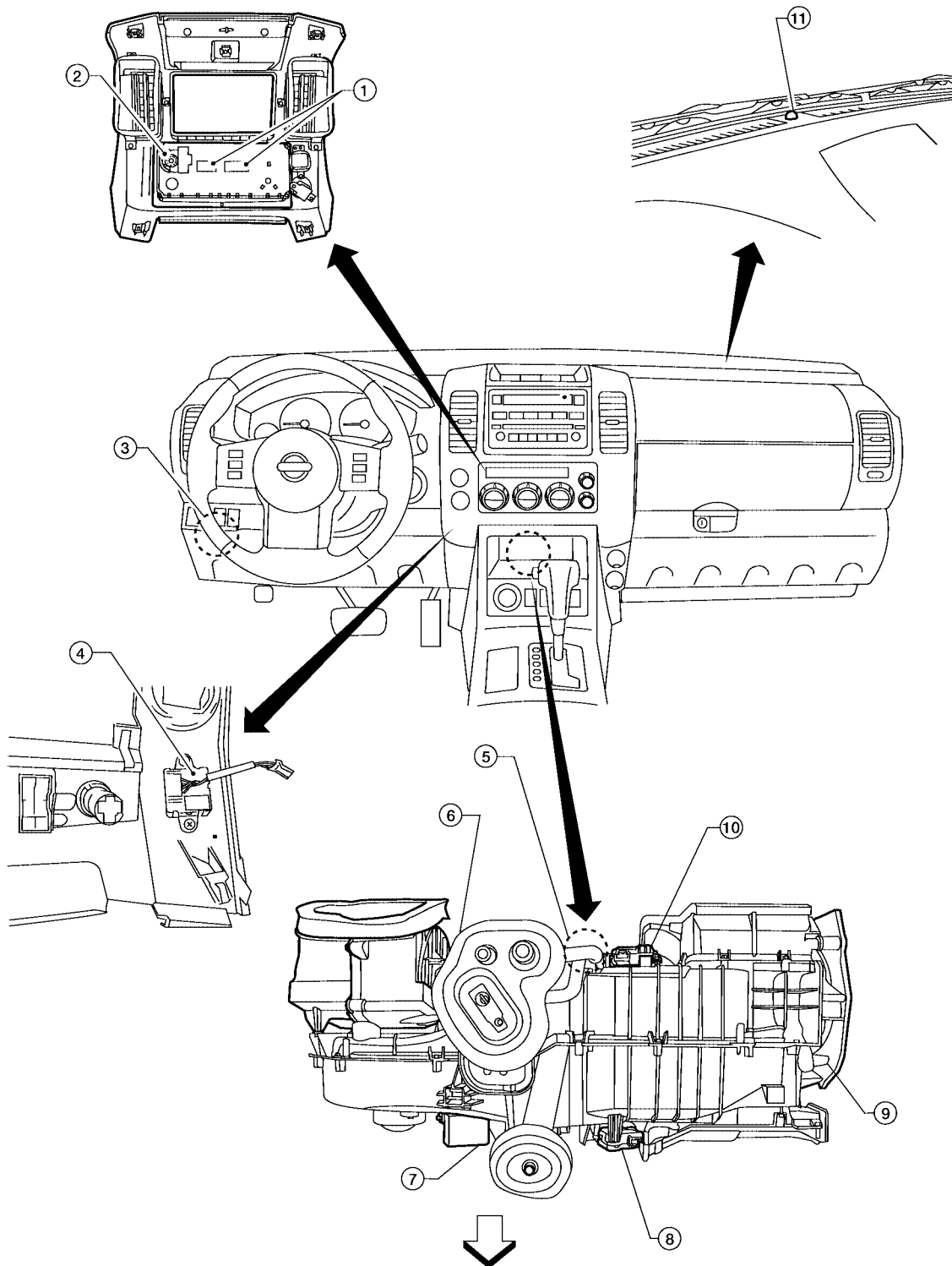

- |   |                                     |                                 |
|---|-------------------------------------|---------------------------------|
| 1. Front air control M49, M50           | 2. Rear blower switch (front) M52   | 3. Rear blower motor relay M163 |
| 4. In-vehicle sensor M32                | 5. Intake sensor M146               | 6. Intake door motor M58        |
| 7. Variable blower control M122         | 8. Air mix door motor (driver) M147 | 9. Mode door motor M142         |
| 10. Air mix door motor (passenger) M143 | 11. Optical sensor M145             |                                 |

WJIA1977E

# TROUBLE DIAGNOSIS

## REAR PASSENGER COMPARTMENT

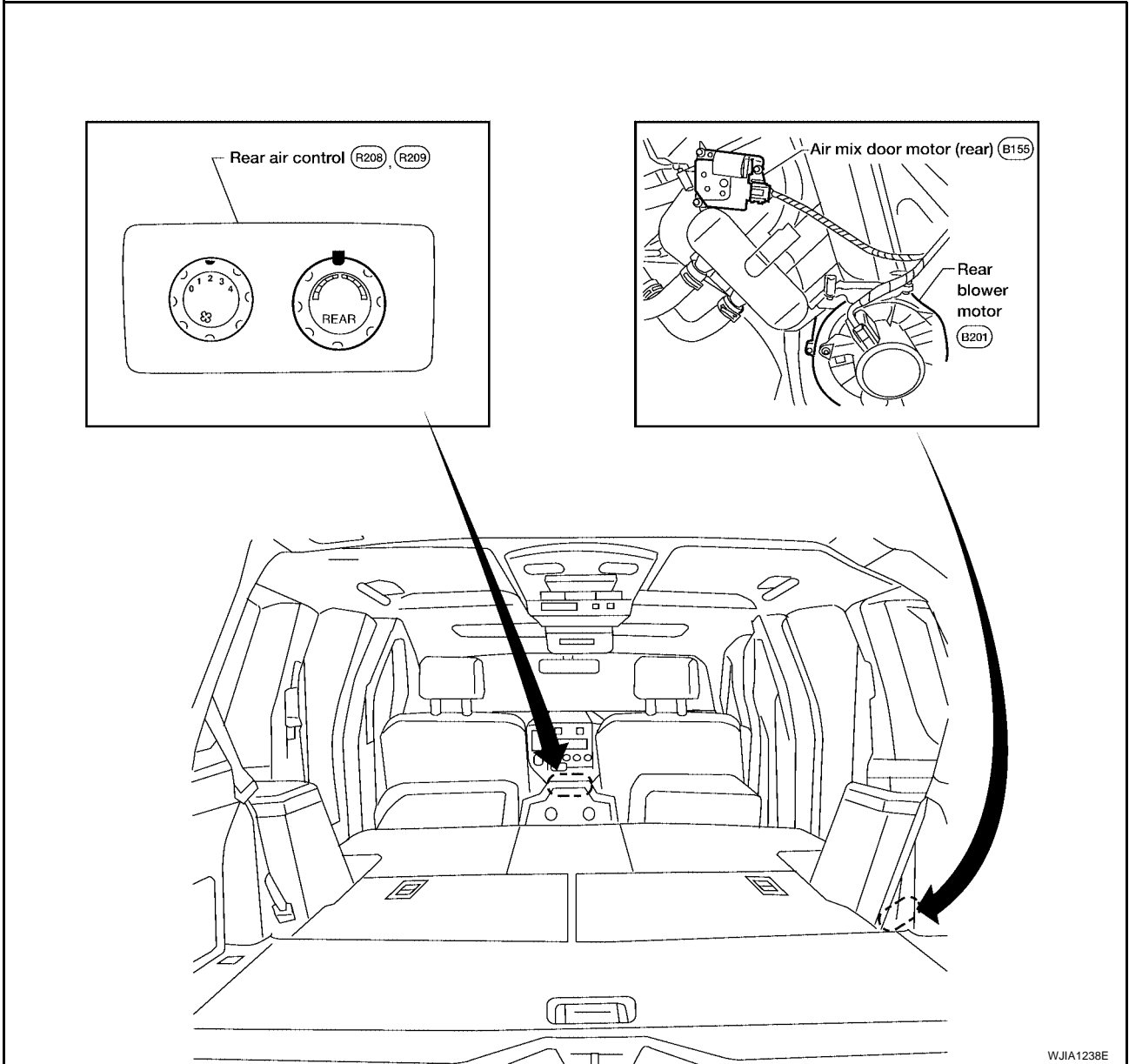

A

B

C

D

E

F

G

H

I

ATC

K

L

M

# TROUBLE DIAGNOSIS

## Schematic

EJS0040Y

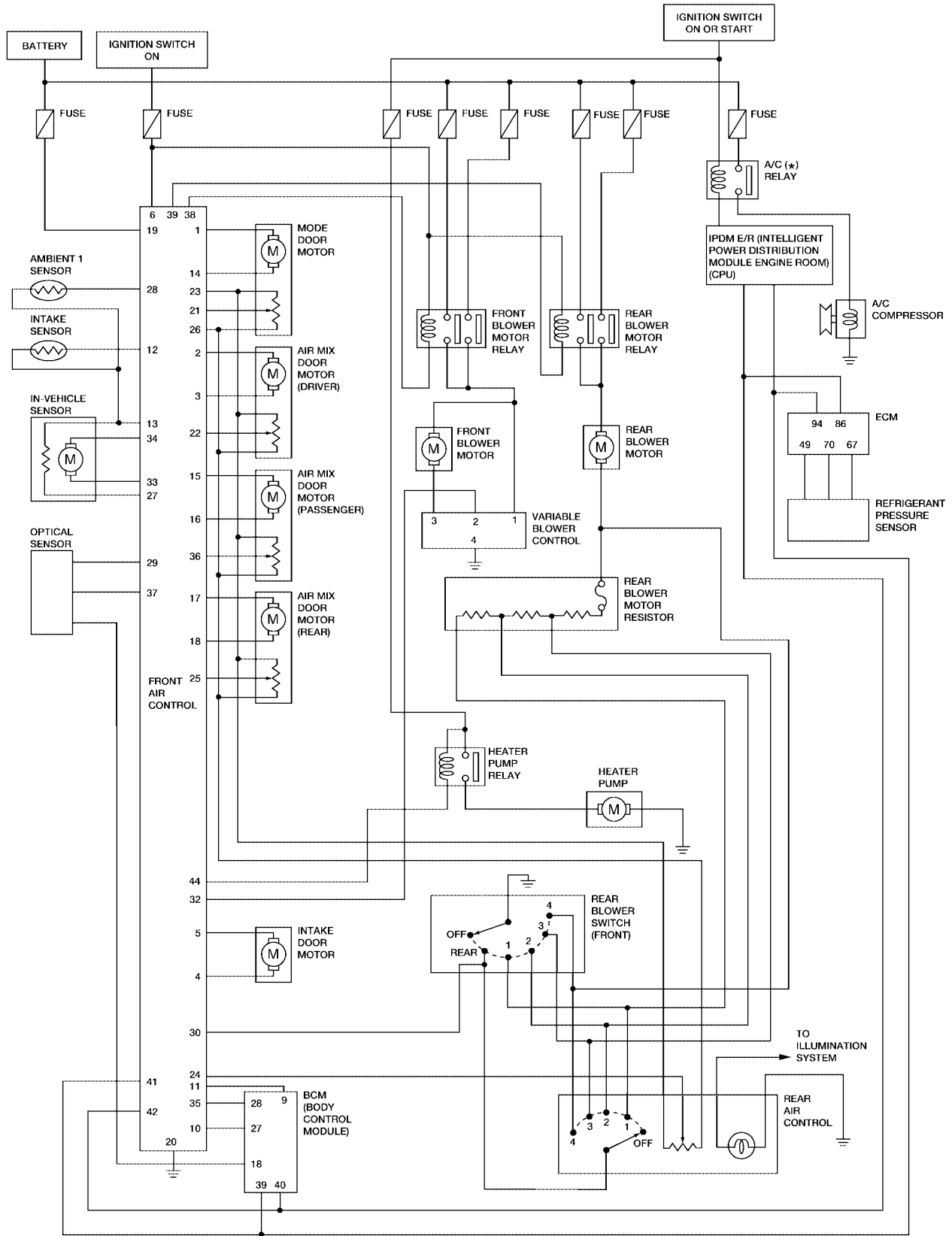

\* : THIS RELAY IS BUILT INTO THE IPDM E/R (INTELLIGENT POWER DISTRIBUTION MODULE ENGINE ROOM)

WJWA0389E



# TROUBLE DIAGNOSIS

## Wiring Diagram —A/C,A—

EJS0040Z

ATC-A/C,A-01

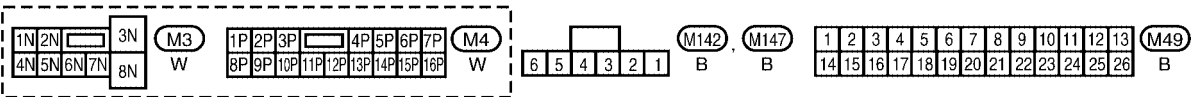
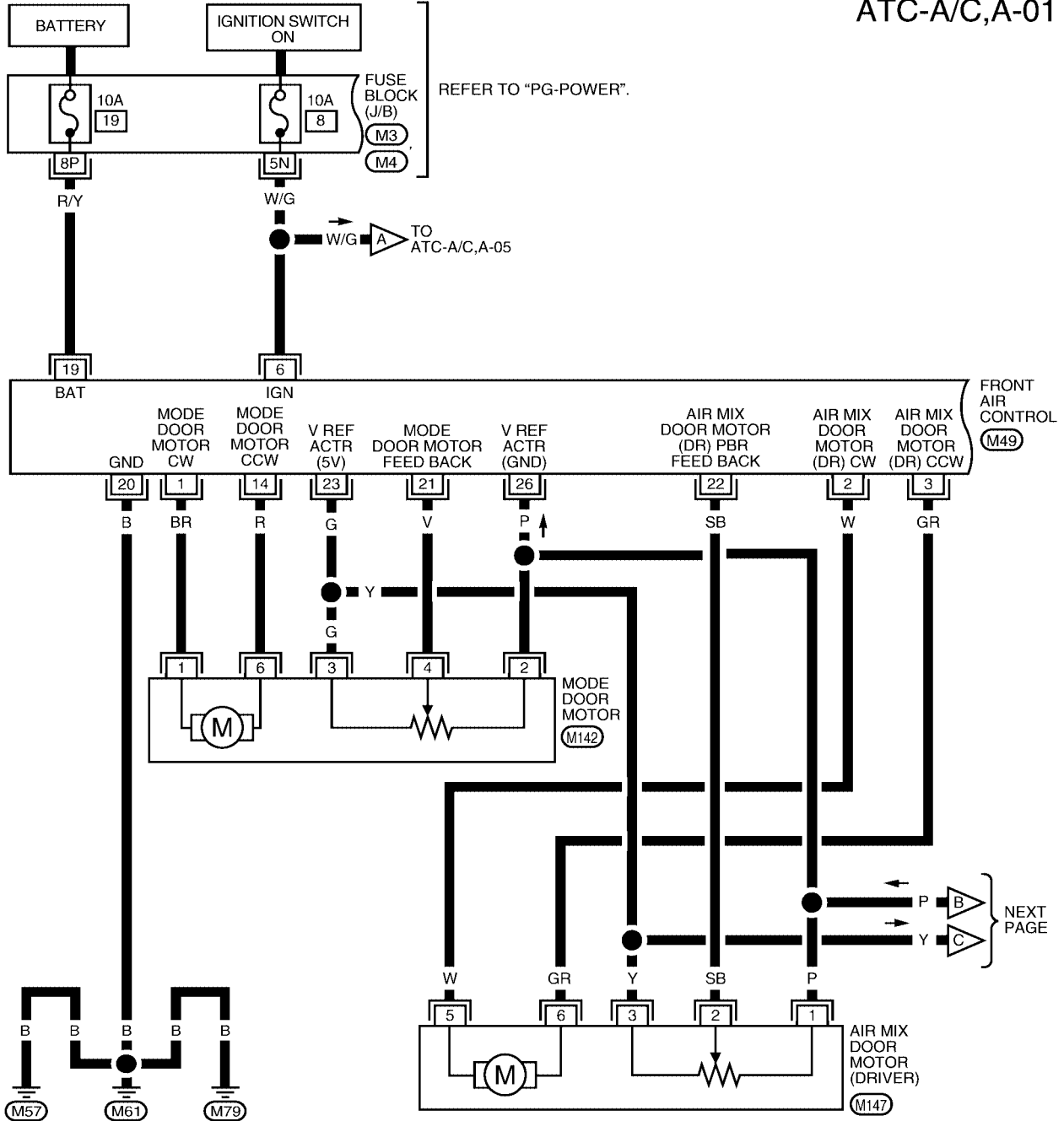

# TROUBLE DIAGNOSIS

ATC-A/C,A-02

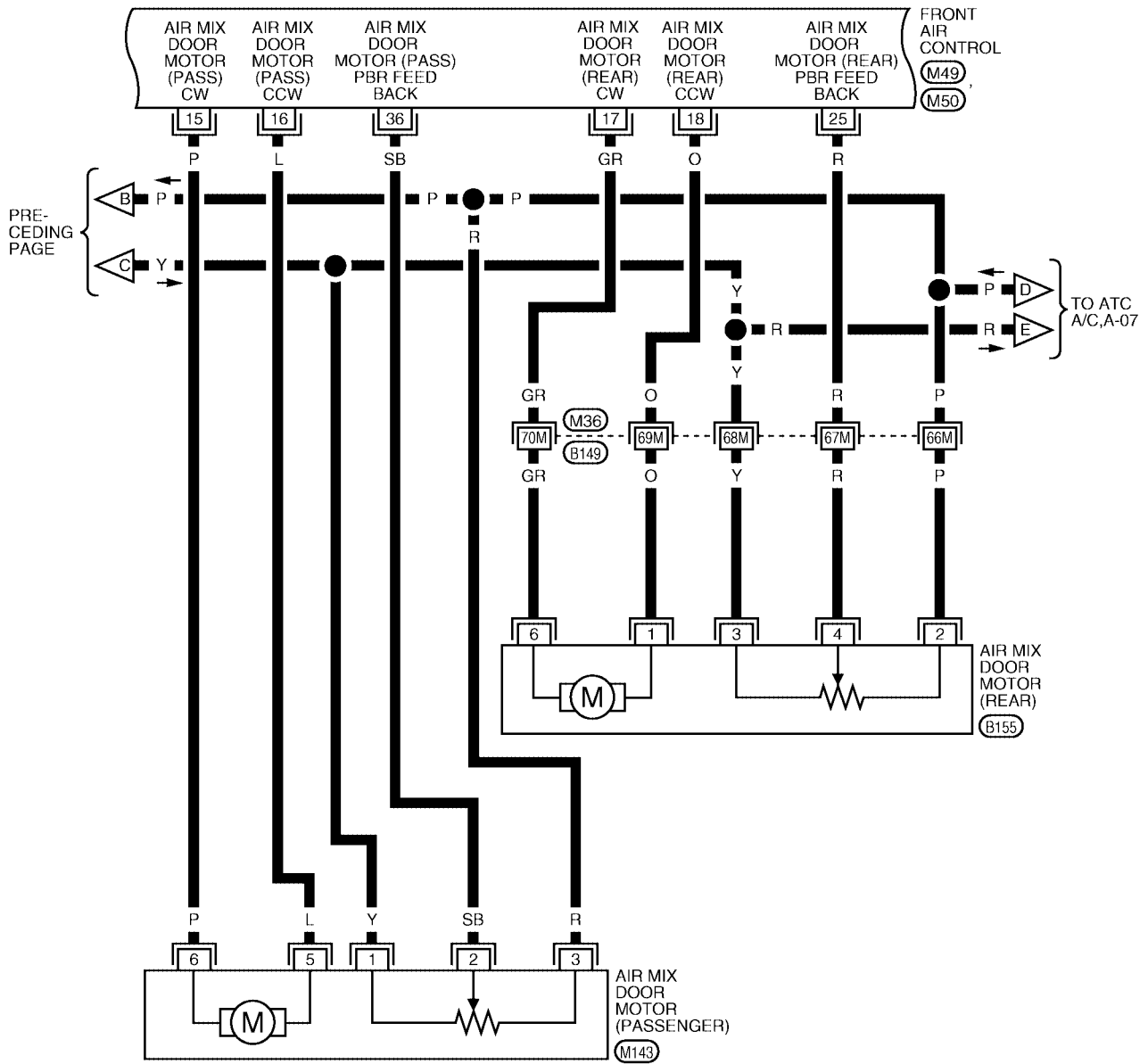

1	2	3	4	5	6	7	8	9	10	11	12	13	M49	27	28	29	30	31	32	33	34	35	M50
14	15	16	17	18	19	20	21	22	23	24	25	26	B	36	37	38	39	40	41	42	43	44	W

6	5	4	3	2	1
---	---	---	---	---	---

M143  
B

B155  
B

REFER TO THE FOLLOWING.  
 M36 - SUPER MULTIPLE JUNCTION (SMJ)

WJWA0277E

# TROUBLE DIAGNOSIS

ATC-A/C,A-03

▬ : DATA LINE

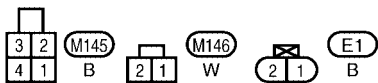
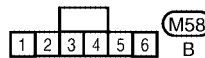
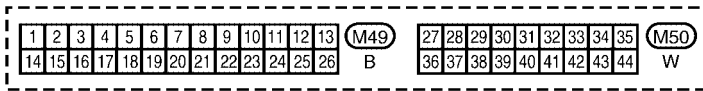
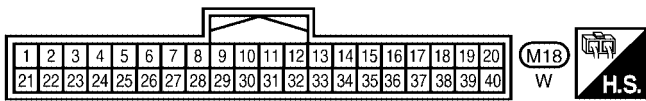
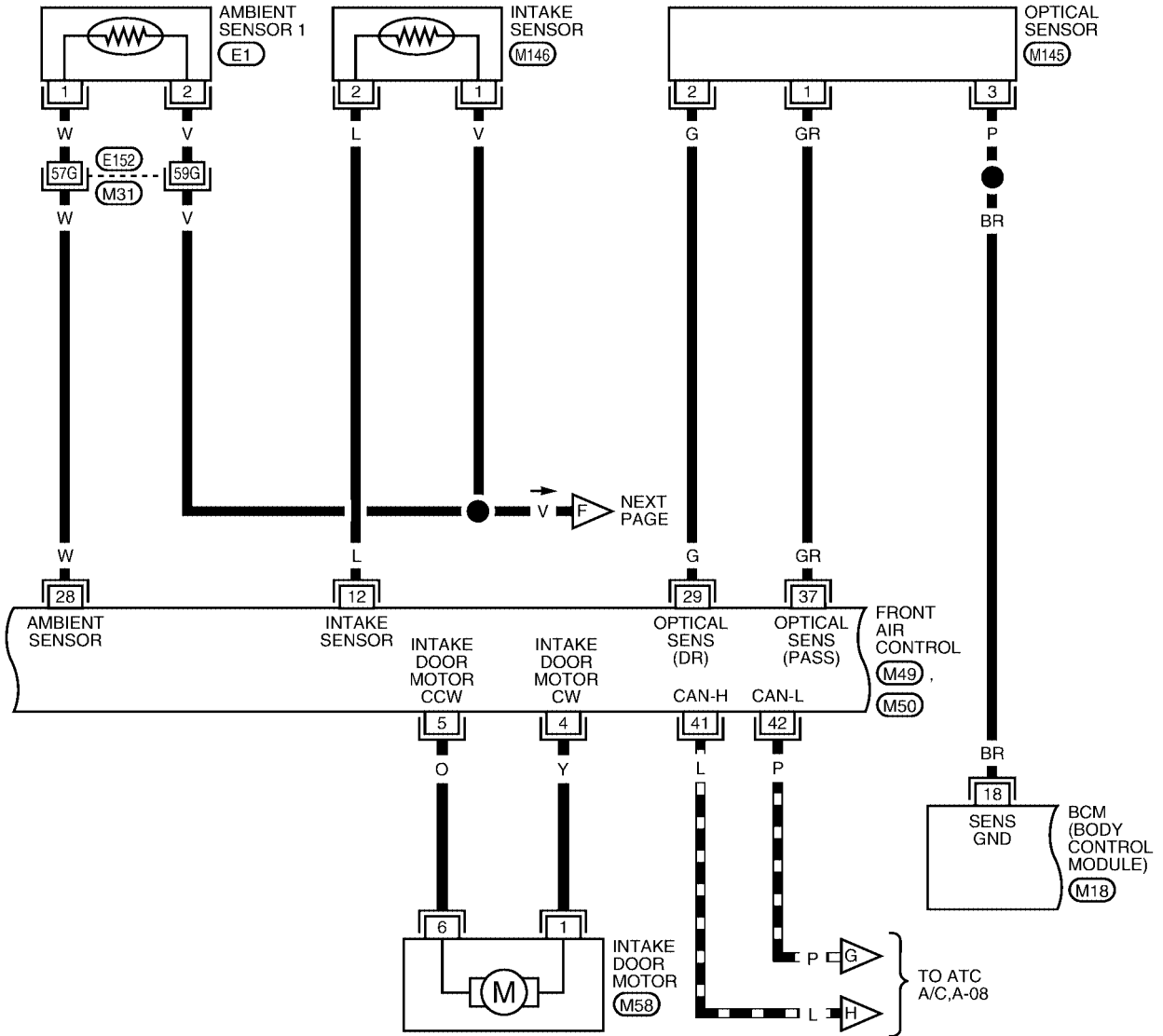

REFER TO THE FOLLOWING.  
 (M31) - SUPER MULTIPLE JUNCTION (SMJ)

WJWA0391E

# TROUBLE DIAGNOSIS

ATC-A/C,A-04

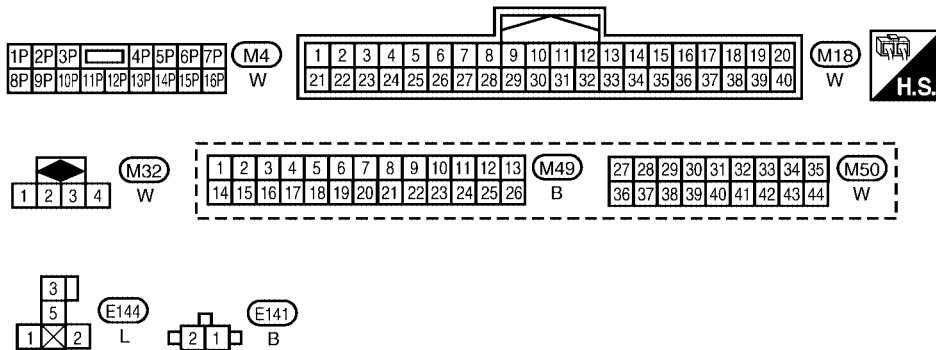
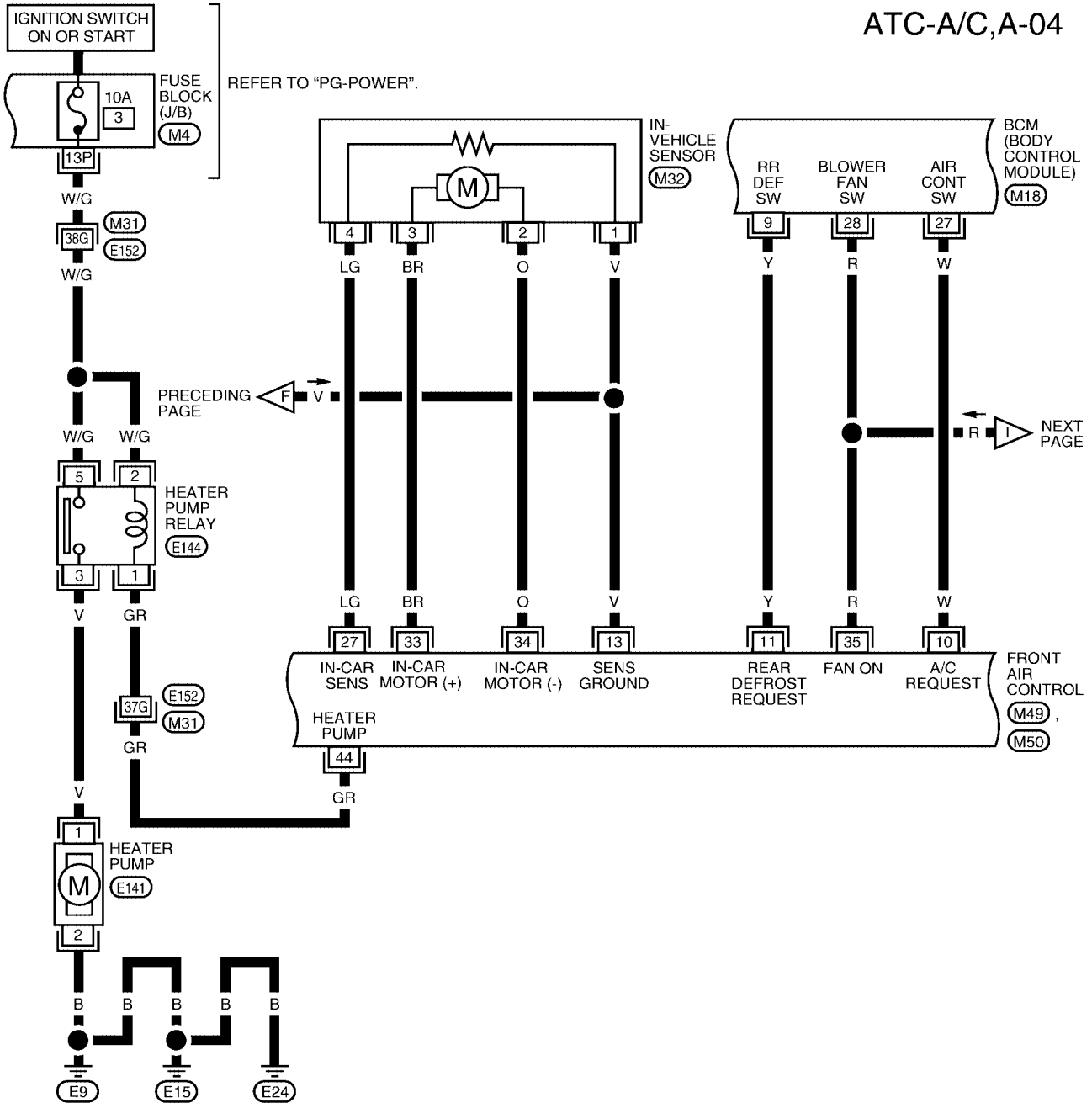

REFER TO THE FOLLOWING.  
**(M31)** - SUPER MULTIPLE JUNCTION (SMJ)

WJWA0392E

# TROUBLE DIAGNOSIS

ATC-A/C,A-05

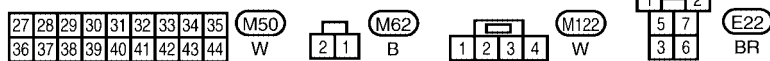
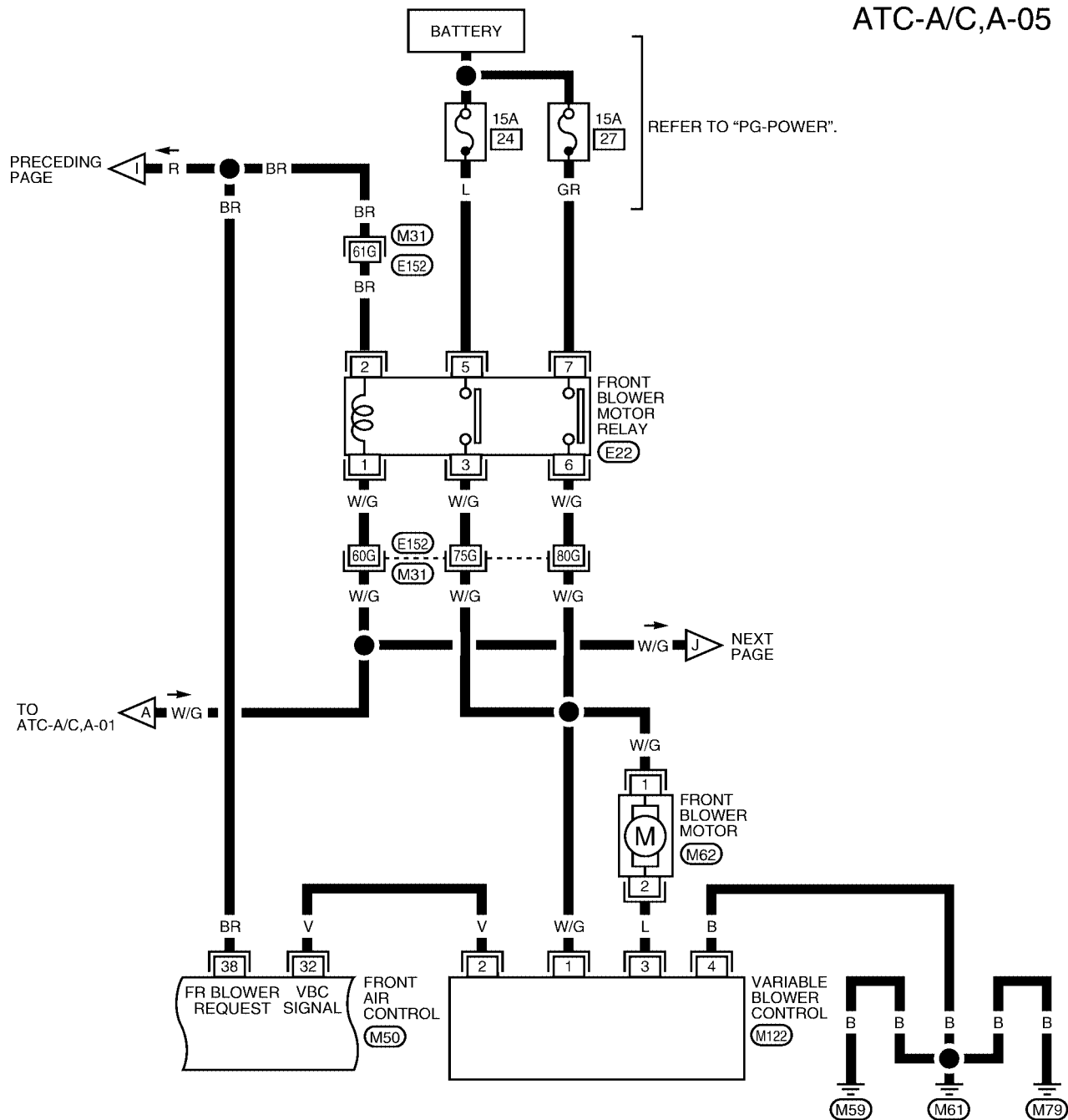

REFER TO THE FOLLOWING.  
 (M31) - SUPER MULTIPLE JUNCTION (SMJ)

WJWA0393E

# TROUBLE DIAGNOSIS

ATC-A/C,A-06

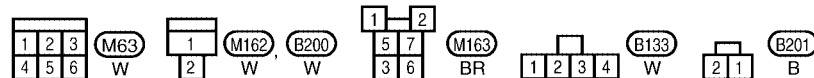
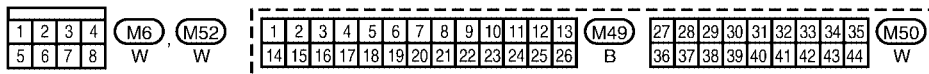
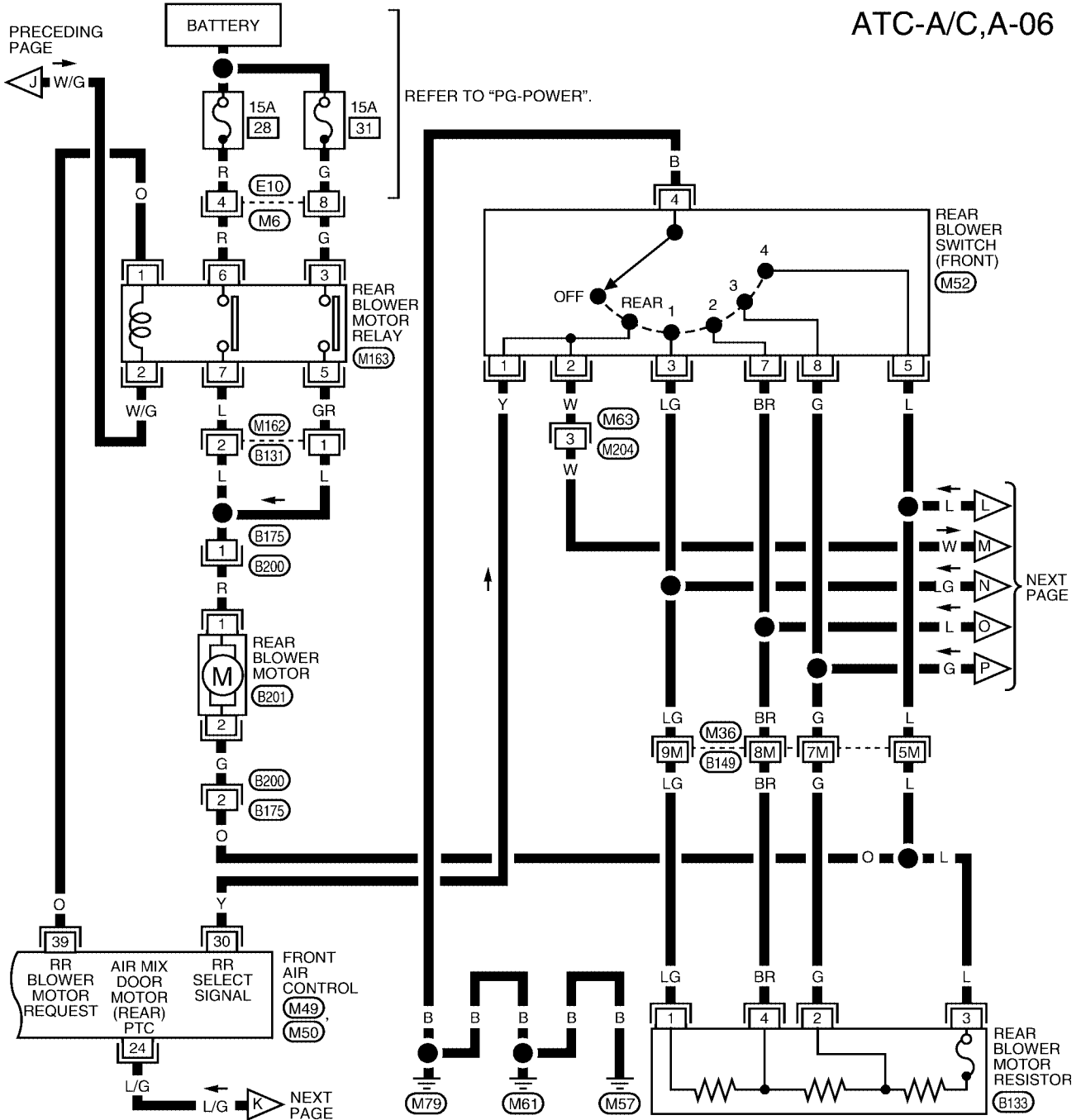

REFER TO THE FOLLOWING.  
**M36** - SUPER MULTIPLE JUNCTION (SMJ)

WJWA0394E

# TROUBLE DIAGNOSIS

ATC-A/C,A-07

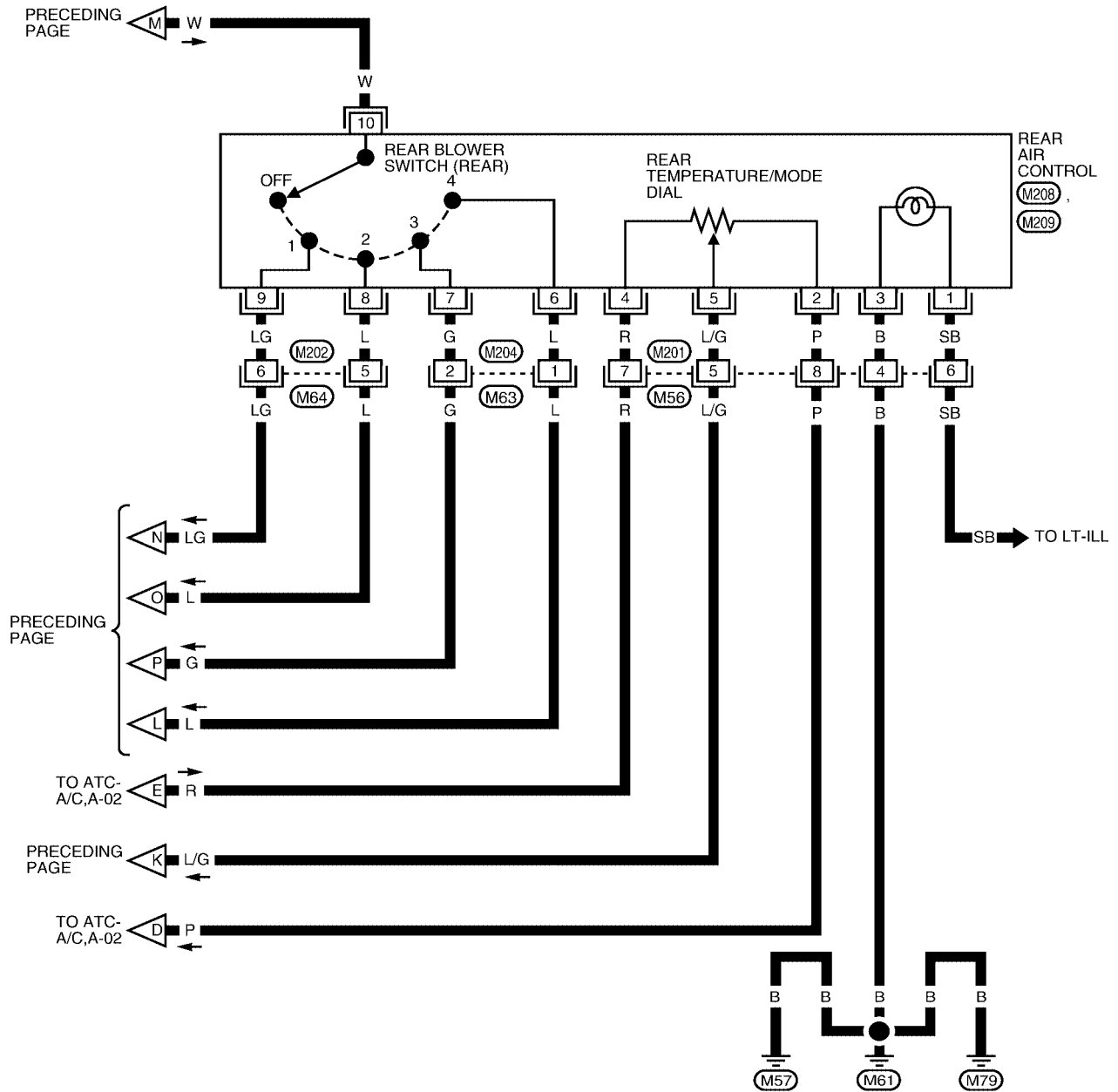

A  
B  
C  
D  
E  
F  
G  
H  
I  
ATC  
K  
L  
M

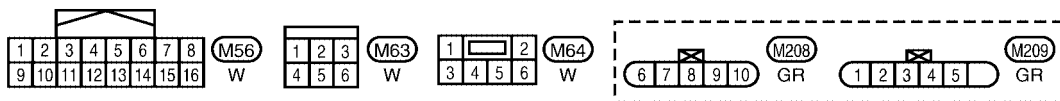

WJWA0194E

# TROUBLE DIAGNOSIS

## ATC-A/C,A-08

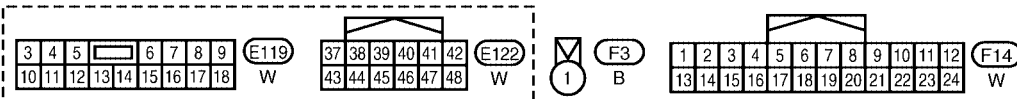
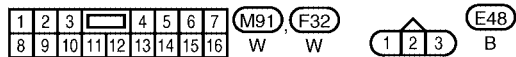
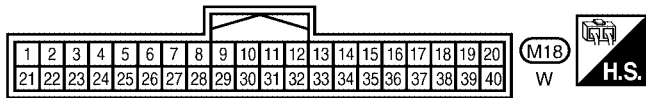
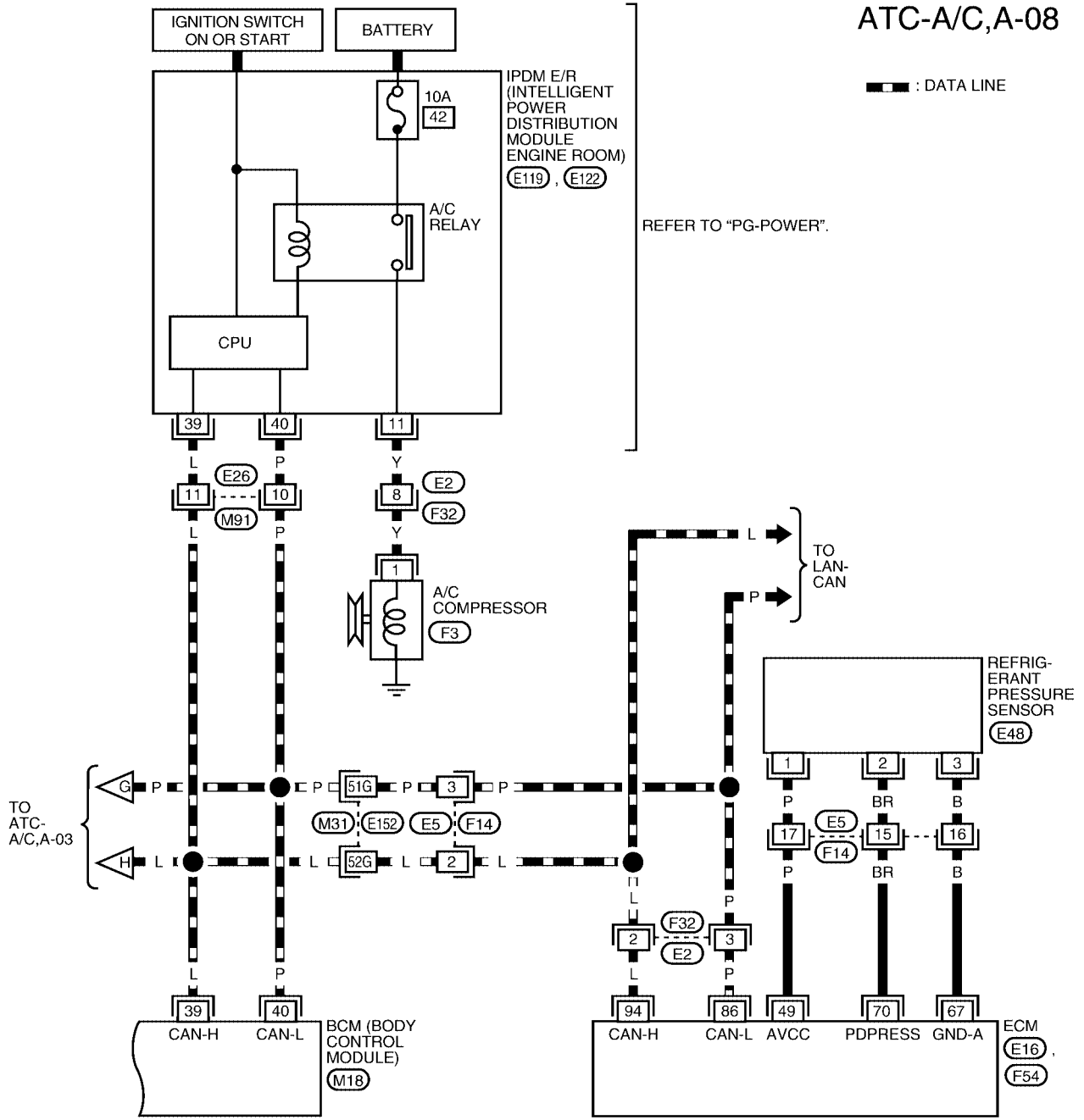

REFER TO THE FOLLOWING.

(E16, F54) - ELECTRICAL UNITS

(M31) - SUPER MULTIPLE JUNCTION (SMJ)

WJWA0395E



# TROUBLE DIAGNOSIS

EJS004P0

## Front Air Control Terminals and Reference Value

Measure voltage between each terminal and ground by following Terminals and Reference Value for front air control.

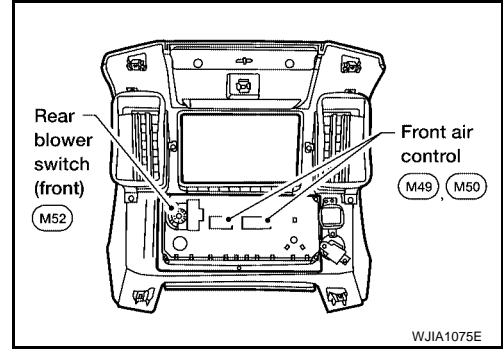

### PIN CONNECTOR TERMINAL LAYOUT

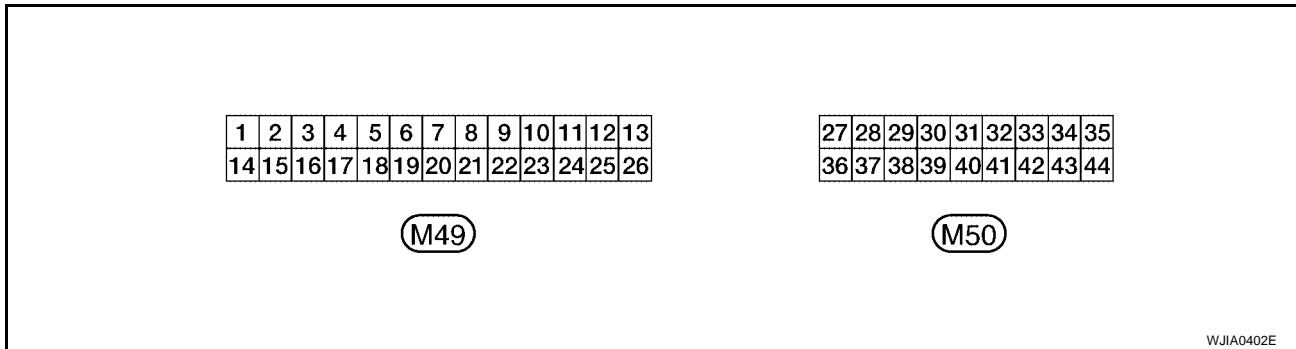

### TERMINALS AND REFERENCE VALUE FOR FRONT AIR CONTROL

Terminal No.	Wire color	Item	Ignition switch	Condition	Voltage (V) (Approx.)
1	BR	Mode door motor CW	ON	Clockwise rotation	Battery voltage
2	W	Air mix door motor (Driver) CW	ON	Clockwise rotation	Battery voltage
3	GR	Air mix door motor (Driver) CCW	ON	Counterclockwise rotation	Battery voltage
4	Y	Intake door motor CW	ON	Counterclockwise rotation	Battery voltage
5	O	Intake door motor CCW	ON	Clockwise rotation	Battery voltage
6	W/G	Power supply for IGN	ON	-	Battery voltage
8	G	Illumination +	ON	Park lamps ON	Battery voltage
9	BR	Illumination -	-	Park lamps ON	<p style="text-align: right;">PIIA2344E</p>
10	W	Compressor ON signal	ON	A/C switch OFF	5V
			ON	A/C switch ON	0V
11	Y	Rear defrost request	ON	-	Battery voltage
12	L	Intake sensor	ON	-	0 - 5V
13	V	Sensor ground	ON	-	0 - 5V
14	R	Mode door motor CCW	ON	Counterclockwise rotation	Battery voltage
15	P	Air mix door motor (Passenger) CW	ON	Clockwise rotation	Battery voltage
16	L	Air mix door motor (Passenger) CCW	ON	Counter clockwise rotation	Battery voltage
17	GR	Air mix door motor (Rear) CW	ON	Clockwise rotation	Battery voltage
18	O	Air mix door motor (Rear) CCW	ON	Counterclockwise rotation	Battery voltage

A  
B  
C  
D  
E  
F  
G  
H  
I  
K  
L  
M

ATC

## TROUBLE DIAGNOSIS

Terminal No.	Wire color	Item	Ignition switch	Condition	Voltage (V) (Approx.)
19	R/Y	Power supply for BAT	-	-	Battery voltage
20	B	Ground	-	-	0V
21	V	Mode door motor feedback	ON	-	0 - 5V
22	SB	Air mix door motor (Driver) feedback	ON	-	0 - 5V
23	G	Power supply for mode door motor PBR	ON	-	5V
24	L/G	Air mix door motor (Rear) PTC	ON	-	0 - 5V
25	R	Air mix door motor (Rear) feedback	ON	-	0 - 5V
26	P	Ground for mode door motor PBR	ON	-	0V
27	LG	In-vehicle sensor signal	ON	-	0 - 5V
28	W	Ambient sensor 1	ON	-	0 - 5V
29	G	Optical sensor (Driver)	ON	-	0 - 5V
30	Y	Rear select signal	ON	-	0V - Battery voltage
32	V	Variable blower control	ON	-	0 - 5V
33	BR	In-vehicle sensor motor (+)	ON	-	Battery voltage
34	O	In-vehicle sensor motor (-)	ON	-	0V
35	R	Fan ON signal	ON	Blower switch OFF	5V
			ON	Blower switch ON	0V
36	SB	Air mix door motor (Passenger) feedback	ON	-	0 - 5V
37	GR	Optical sensor (Passenger)	ON	-	0 - 5V
38	BR	Front blower request	ON	Front blower motor OFF	Battery voltage
				Front blower motor ON	0V
39	O	Rear blower request	ON	Front blower motor OFF	Battery voltage
				Front blower motor ON	0V
41	L	CAN-H	ON	-	0 - 5V
42	P	CAN-L	ON	-	0 - 5V
44	GR	Heater pump request	ON	Heater pump on	0V
				Heater pump off	Battery voltage

# TROUBLE DIAGNOSIS

EJS004P1

## A/C System Self-diagnosis Function DESCRIPTION

The self-diagnostic system diagnoses sensors, CAN system, battery voltage and stuck button on front air control. Refer to applicable sections (items) for details. Fault codes (if any are present) will be displayed in the ambient temperature display area (with navi) and displayed in the driver temp display area (without navi). Refer to [ATC-52, "SELF-DIAGNOSIS CODE CHART"](#).

Ignition must be ON to run self test.  
Self test must be run at an ambient of at least 10°C(50°F).

### Self Test Via AV Switch w/navi Unit (color display)

Note: Radio must be OFF.

1. On the AV switch, hold the memory "4" button and twist the audio "POWER/VOLUME" knob until the Self Diagnostic screen shows on the display.
2. Scroll down and select "Confirmation/Adjustment" with the joystick.
3. Scroll over and select the "Auto Climate Control" with the joystick to start the self-test.
4. The fan bars will flash on the display during the self-test, and then the fault codes will display in the ambient temperature area. They will continue scrolling until diagnostic mode is exited.
5. Exit by pressing the "BACK" button on AV switch until display returns to its normal operation screen. HVAC system will be OFF.

### Self Test Without Navi

1. Press the AUTO button.
2. Twist the fan knob to the left & twist the passenger knob (either way) at the same time.
3. Release the knobs and then press the AUTO button within 2 seconds to start the self test.
4. The fan bars will flash on the display and then the fault codes will be displayed on the LCD. They will continue scrolling until diagnostic mode is exited.
5. To exit diagnostic mode, press any button (the system will turn OFF).

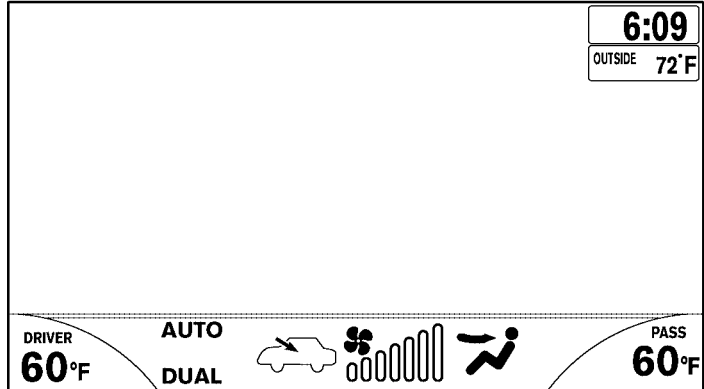

WITH NAVI

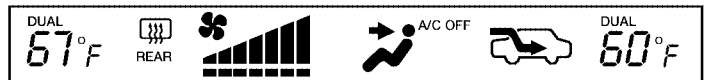

WITHOUT NAVI

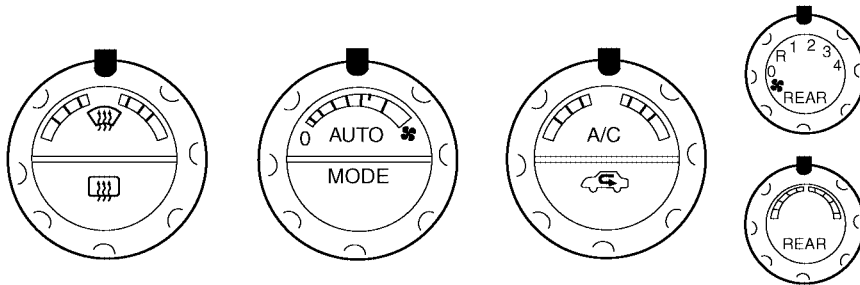

WJIA1879E

# TROUBLE DIAGNOSIS

## SELF-DIAGNOSIS CODE CHART

Code No.	Description	Reference page
02	EE changed by calibration (EE/ROM malfunction)	<a href="#">ATC-127. "FRONT AIR CONTROL"</a>
12	Air mix door motor (Driver) circuit malfunction	<a href="#">ATC-65. "DIAGNOSTIC PROCEDURE FOR AIR MIX DOOR MOTOR (DRIVER)"</a>
22	Air mix door motor (Passenger) circuit malfunction	<a href="#">ATC-67. "DIAGNOSTIC PROCEDURE FOR AIR MIX DOOR MOTOR (PASSENGER)"</a>
30	In-vehicle sensor circuit out of range (short)	<a href="#">ATC-120. "In-vehicle Sensor Circuit"</a>
31	In-vehicle sensor circuit out of range (open)	
38	Air mix door motor (rear) circuit malfunction	<a href="#">ATC-69. "DIAGNOSTIC PROCEDURE FOR AIR MIX DOOR MOTOR (REAR)"</a>
40	Ambient sensor 1 circuit short	<a href="#">ATC-117. "Ambient Sensor 1 Circuit"</a>
41	Ambient sensor 1 circuit open	
50	Optical sensor (Passenger) circuit open or short	<a href="#">ATC-123. "Optical Sensor Circuit"</a>
52	Optical sensor (Driver) circuit open or short	
56	Intake sensor circuit short	<a href="#">ATC-125. "Intake Sensor Circuit"</a>
57	Intake sensor circuit open	
80	CAN bus fault	<a href="#">LAN-25. "CAN COMMUNICATION"</a>
81	BCM CAN message missing	
82	Intake door motor circuit malfunction	<a href="#">ATC-74. "DIAGNOSTIC PROCEDURE FOR INTAKE DOOR MOTOR"</a>
92	Mode door motor circuit malfunction	<a href="#">ATC-59. "Mode Door Motor Circuit"</a>

# TROUBLE DIAGNOSIS

EJS004P2

## Operational Check (Front)

The purpose of the operational check is to confirm that the system operates properly.

**Conditions : Engine running and at normal operating temperature**

### CHECKING MEMORY FUNCTION

1. Set the temperature to 32°C (90°F).
2. Turn front blower control dial counterclockwise until system shuts OFF.
3. Turn ignition switch OFF.
4. Turn ignition switch ON.
5. Press the AUTO switch.
6. Confirm that the set temperature remains at previous temperature.

7. Turn front blower control dial counterclockwise until system shuts OFF.

If NG, go to trouble diagnosis procedure for [ATC-116, "Memory Function"](#) .  
If OK, continue with next check.

### CHECKING BLOWER

1. Press the AUTO switch. Blower should operate on low speed. The blower symbol should have one blade lit on display.
2. Turn the front blower control dial again, and continue checking blower speed and blower symbol until all speeds are checked.
3. Leave blower on maximum speed.

If NG, go to trouble diagnosis procedure for [ATC-77, "DIAGNOSTIC PROCEDURE FOR BLOWER MOTOR"](#) .  
If OK, continue with next check.

### CHECKING DISCHARGE AIR





1. Press MODE switch four times and the DEF () switch.
2. Each position indicator should change shape on display.
3. Confirm that discharge air comes out according to the air distribution table. Refer to [ATC-30, "Discharge Air Flow"](#) .

Mode door position is checked in the next step.

If NG, go to trouble diagnosis procedure for [ATC-59, "Mode Door Motor Circuit"](#) .  
If OK, continue the check.



#### NOTE:

Confirm that the compressor clutch is engaged (sound or visual inspection) and intake door position is at fresh when the DEF or D/F is selected.

Mode door position	Air outlet/distribution		
	Vent	Foot	Defroster
	100%	0%	—
	60%	40%	—
	18%	64%	18%
	14%	64%	33%
	—	13%	83%

Airflow always present at driver and passenger side demisters

### CHECKING RECIRCULATION

1. Press recirculation () switch one time. Recirculation indicator should illuminate.
2. Press recirculation () switch one more time. Recirculation indicator should go off.
3. Listen for intake door position change (blower sound should change slightly).

# TROUBLE DIAGNOSIS

---

If NG, go to trouble diagnosis procedure for [ATC-72, "Intake Door Motor Circuit"](#) .

If OK, continue next check.

## NOTE:

Confirm that the compressor clutch is engaged (sound or visual inspection) and intake door position is at fresh when the DEF or D/F is selected.

## CHECKING TEMPERATURE DECREASE

1. Rotate temperature control dial (driver side) counterclockwise until 16°C (60°F) is displayed.
2. Check for cold air at appropriate discharge air outlets.

If NG, listen for sound of air mix door motor operation. If OK, go to trouble diagnosis procedure for [ATC-102, "Insufficient Cooling"](#) . If air mix door motor appears to be malfunctioning, go to [ATC-65, "DIAGNOSTIC PROCEDURE FOR AIR MIX DOOR MOTOR \(DRIVER\)"](#) or [ATC-67, "DIAGNOSTIC PROCEDURE FOR AIR MIX DOOR MOTOR \(PASSENGER\)"](#) .

If OK, continue the check.

## CHECKING TEMPERATURE INCREASE

1. Rotate temperature control dial clockwise (driver side) until 32°C (90°F) is displayed.
2. Check for hot air at appropriate discharge air outlets.

If NG, listen for sound of air mix door motor operation. If OK, go to trouble diagnosis procedure for [ATC-109, "Insufficient Heating"](#) . If air mix door motor appears to be malfunctioning, go to [ATC-65, "DIAGNOSTIC PROCEDURE FOR AIR MIX DOOR MOTOR \(DRIVER\)"](#) or [ATC-67, "DIAGNOSTIC PROCEDURE FOR AIR MIX DOOR MOTOR \(PASSENGER\)"](#) .

If OK, continue with next check.

## CHECK A/C SWITCH

1. Press A/C switch when AUTO switch is ON, or in manual mode.
2. A/C switch indicator will turn ON.
  - Confirm that the compressor clutch engages (sound or visual inspection).

## NOTE:

If current mode setting is DEF or D/F compressor clutch may already be engaged.

If NG, go to trouble diagnosis procedure for [ATC-96, "Magnet Clutch Circuit"](#) .

If OK, continue with next check.

## CHECKING AUTO MODE

1. Press AUTO switch.
2. Display should indicate AUTO.
  - If ambient temperature is warm, and selected temperature is cool, confirm that the compressor clutch engages (sound or visual inspection). (Discharge air and blower speed will depend on ambient, in-vehicle, and set temperatures.)

If NG, go to trouble diagnosis procedure for [ATC-56, "Power Supply and Ground Circuit for Front Air Control"](#) , then if necessary, trouble diagnosis procedure for [ATC-96, "Magnet Clutch Circuit"](#) .

If all operational checks are OK (symptom cannot be duplicated), go to malfunction simulation tests in [ATC-36, "How to Perform Trouble Diagnosis for Quick and Accurate Repair"](#) and perform tests as outlined to simulate driving conditions environment. If symptom appears, refer to [ATC-36, "How to Perform Trouble Diagnosis for Quick and Accurate Repair"](#) , [ATC-36, "SYMPTOM TABLE"](#) and perform applicable trouble diagnosis procedures.

# TROUBLE DIAGNOSIS

EJS004P3

## Operational Check (Rear)

The purpose of the operational check is to confirm that the system operates properly.

**Conditions** : Engine running and at normal operating temperature

### CHECKING BLOWER

1. Turn the rear blower control dial counterclockwise to switch position "1". Fan should operate on low speed.
2. Turn the rear blower control dial clockwise to switch positions "2", "3", and "4" until all speeds are checked.
3. Leave fan on maximum speed.

If NG, go to trouble diagnosis procedure for [ATC-82, "Rear Blower Motor Circuit"](#) .

If OK, continue the check.

### CHECKING TEMPERATURE DECREASE

1. Rotate temperature and mode dial fully counterclockwise.
2. Check for cold air at appropriate discharge air outlets.

If NG, listen for sound of air mix door motor operation. If OK, go to trouble diagnosis procedure for [ATC-102, "Insufficient Cooling"](#) . If air mix door motor appears to be malfunctioning, go to [ATC-69, "DIAGNOSTIC PROCEDURE FOR AIR MIX DOOR MOTOR \(REAR\)"](#) .

If OK, continue the check.

### CHECKING TEMPERATURE INCREASE

1. Rotate temperature and mode dial clockwise.
2. Check for hot air at appropriate discharge air outlets.

If NG, listen for sound of air mix door motor operation. If OK, go to trouble diagnosis procedure for [ATC-109, "Insufficient Heating"](#) . If air mix door motor appears to be malfunctioning, go to [ATC-69, "DIAGNOSTIC PROCEDURE FOR AIR MIX DOOR MOTOR \(REAR\)"](#) .

If OK, continue the check.

A

B

C

D

E

F

G

H

I

ATC

K

L

M

# TROUBLE DIAGNOSIS

EJS004P4

## Power Supply and Ground Circuit for Front Air Control

SYMPTOM: A/C system does not come on.

### INSPECTION FLOW

1. Confirm symptom by performing the following operational check.

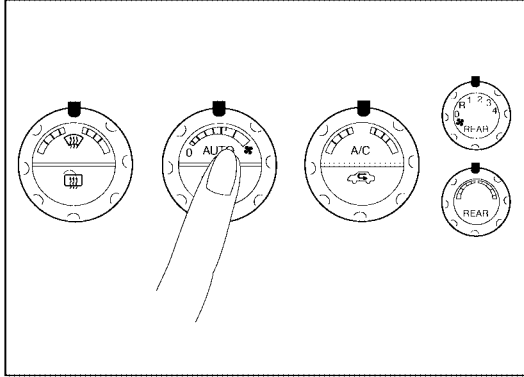

#### OPERATIONAL CHECK – AUTO mode

- Press AUTO switch.
- Display should indicate AUTO.  
Confirm that the compressor clutch engages (Sound or visual inspection).  
(Discharge air and blower speed will depend on ambient, in-vehicle and set temperatures.)

If OK (symptom cannot be duplicated), perform complete operational check (\*2).  
If NG (symptom is confirmed), continue with STEP-2 following.

2. Check for any service bulletins.

3. Check Main Power Supply and Ground Circuit. (\*1)

4. Replace front air control.

\*1 [ATC-56. "Power Supply and Ground Circuit for Front Air Control"](#)

\*2 [ATC-53. "Operational Check \(Front\)"](#)  
or [ATC-55. "Operational Check \(Rear\)"](#)

WJIA1439E



# TROUBLE DIAGNOSIS

## COMPONENT DESCRIPTION

### Front Air Control

The front air control has a built-in microcomputer which processes information sent from various sensors needed for air conditioner operation. The air mix door motors, mode door motor, intake door motor, blower motor and compressor are then controlled.

The front air control is unitized with control mechanisms. When the various switches and temperature dials are operated, data is input to the front air control.

Self-diagnostic functions are also built into the front air control to provide quick check of malfunctions in the auto air conditioner system.

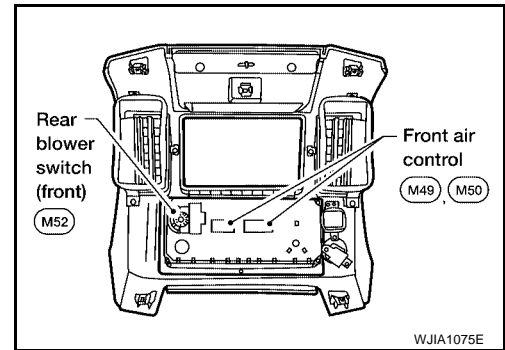

### Potential Temperature Control (PTC)

There are two PTCs (passenger and driver) built into the front air control. They can be set at an interval of 0.5°C (1.0°F) in the 16°C (60°F) to 32°C (90°F) temperature range by rotating the temperature dial. The set temperature is displayed.

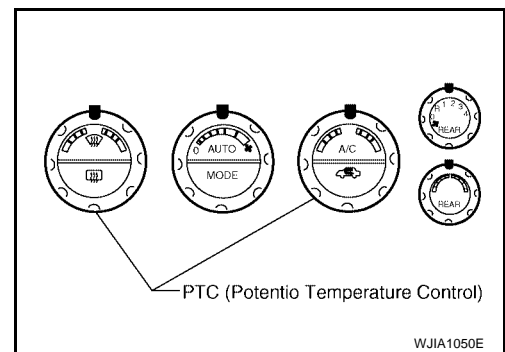

## DIAGNOSTIC PROCEDURE FOR A/C SYSTEM

SYMPTOM: A/C system does not come on.

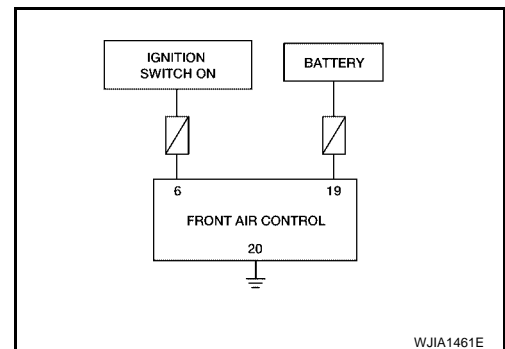

A  
B  
C  
D  
E  
F  
G  
H  
I  
ATC  
K  
L  
M

# TROUBLE DIAGNOSIS

## 1. CHECK POWER SUPPLY CIRCUITS FOR FRONT AIR CONTROL

1. Disconnect front air control connector.
2. Check voltage between front air control harness connector M49 terminals 6 and 19, and ground.

Terminals		Ignition switch position			
(+)		(-)	OFF	ACC	ON
Front air control connector	Terminal No.				
M49	6	Ground	Approx. 0V	Approx. 0V	Battery voltage
M49	19		Battery voltage	Battery voltage	Battery voltage

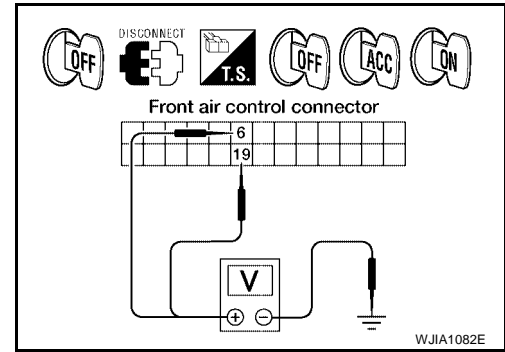

### OK or NG

OK >> GO TO 2.

NG >> Check 10A fuses [Nos. 8 and 19, located in the fuse block (J/B)]. Refer to [PG-83](#).

- If fuses are OK, check harness for open circuit. Repair or replace as necessary.
- If fuses are NG, replace fuse and check harness for short circuit. Repair or replace as necessary.

## 2. CHECK GROUND CIRCUIT FOR FRONT AIR CONTROL

1. Turn ignition switch OFF.
2. Check continuity between front air control harness connector M49 terminal 20 and ground.

**20 - Ground : Continuity should exist.**

### OK or NG

OK >> Replace front air control. Refer to [ATC-127, "FRONT AIR CONTROL"](#).

NG >> Repair harness or connector.

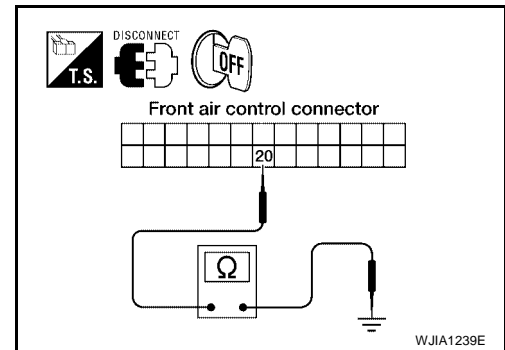

# TROUBLE DIAGNOSIS

EJS004P5

## Mode Door Motor Circuit

SYMPTOM:

- Air outlet does not change.
- Mode door motor does not operate normally.

### INSPECTION FLOW

1. Confirm symptom by performing the following operational check.

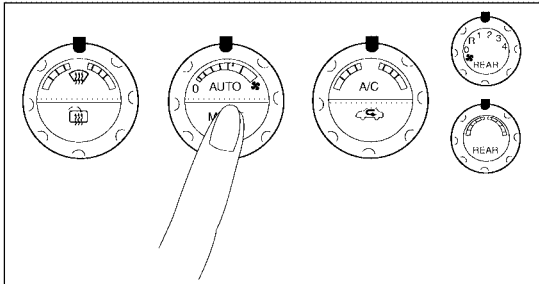

#### OPERATIONAL CHECK – Discharge air

- Press mode switch four times and DEF switch.
- Each position indicator should change shape. (on display)

#### Discharge air flow

Mode door position	Air outlet/distribution		
	Vent	Foot	Defroster
	100%	–	–
	60%	40%	–
	18%	64%	18%
	14%	53%	33%
	–	13%	83%

- Confirm that discharge air comes out according to the air distribution table at left. Refer to "Discharge Air Flow" (\*1).

#### NOTE:

- If OK (symptom cannot be duplicated), perform complete operational check (\*2).
- If NG (symptom is confirmed), continue with STEP-2 following.
- Confirm that the compressor clutch is engaged (visual inspection) and intake door position is at FRESH when DEF or D/F is selected.

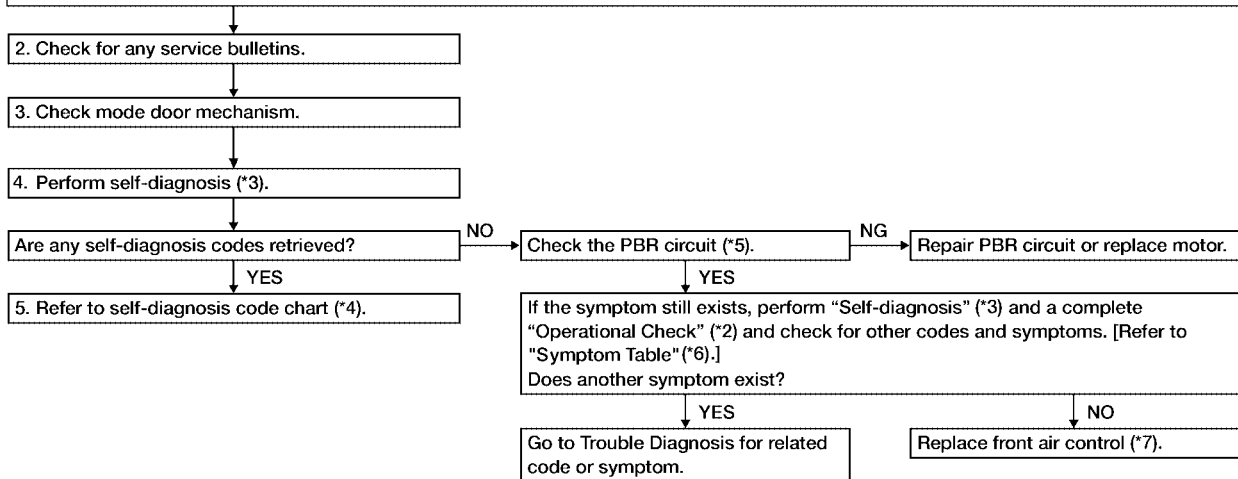

\*1 [ATC-30. "Discharge Air Flow"](#)

\*2 [ATC-53. "Operational Check \(Front\)"](#)

\*3 [ATC-51. "A/C System Self-diagnosis Function"](#)

\*4 [ATC-52. "SELF-DIAGNOSIS CODE CHART"](#)

\*5 [ATC-61. "DIAGNOSTIC PROCEDURE FOR MODE DOOR MOTOR"](#)

\*6 [ATC-36. "SYMPTOM TABLE"](#)

\*7 [ATC-127. "FRONT AIR CONTROL"](#)

WJIA1686E

# TROUBLE DIAGNOSIS

## SYSTEM DESCRIPTION

### Component Parts

Mode door control system components are:

- Front air control
- Mode door motor
- PBR (built into mode door motor)
- In-vehicle sensor
- Ambient sensor
- Optical sensor
- Intake sensor

### System Operation

The mode door position (vent, B/L, foot, and defrost) is set by the front air control by means of the mode door motor. When a mode door position is selected on the front air control, voltage is applied to one circuit of the mode door motor while ground is applied to the other circuit, causing the mode door motor to rotate. The direction of rotation is determined by which circuit has voltage applied to it, and which one has ground applied to it. The front air control monitors the mode door position by measuring the voltage signal on the PBR circuit.

In AUTO mode the mode door position is set by the front air control which determines the proper position based on inputs from the in-vehicle sensor, ambient sensor, optical sensor, intake sensor, and the temperature selected by the driver or passenger.

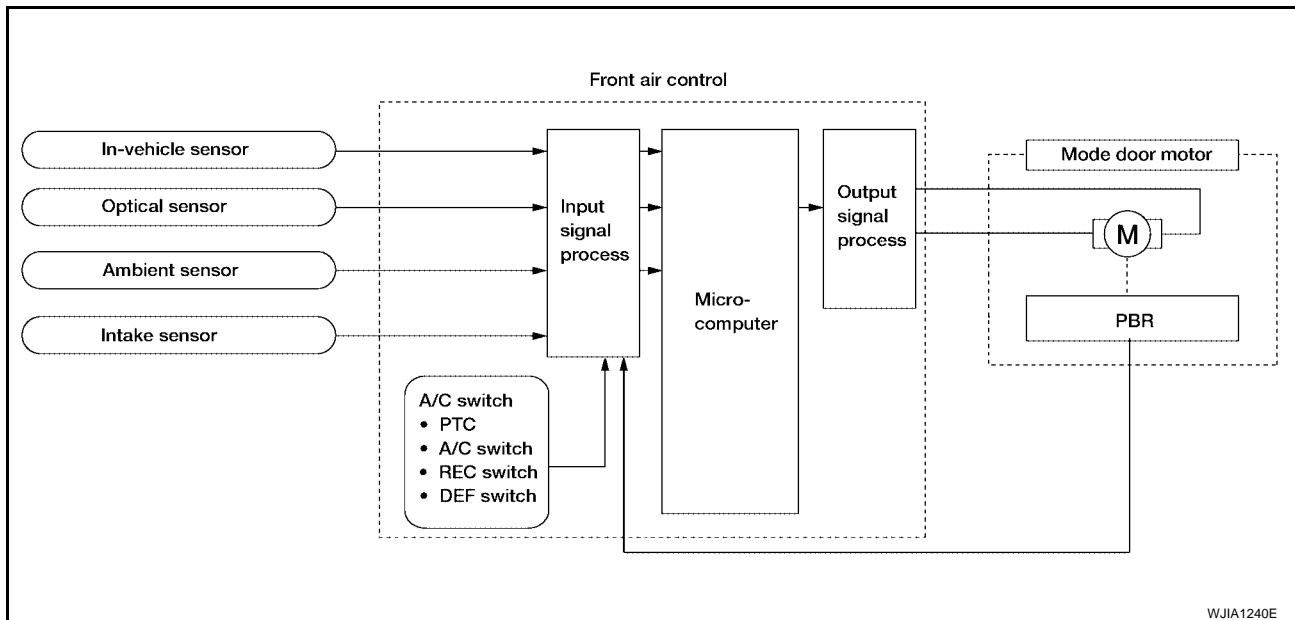

### Mode Door Control Specification

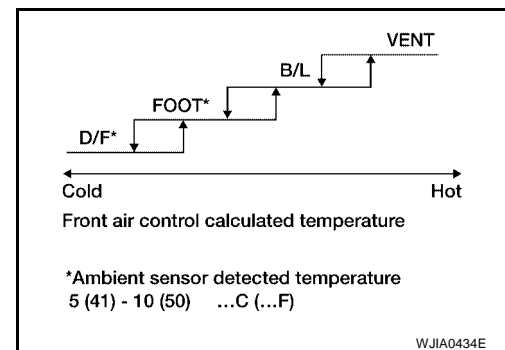

# TROUBLE DIAGNOSIS

## COMPONENT DESCRIPTION

### Mode Door Motor

The mode door motor is attached to the heater & cooling unit assembly. It rotates so that air is discharged from the outlet as indicated by the front air control. Motor rotation is conveyed to a link which activates the mode door.

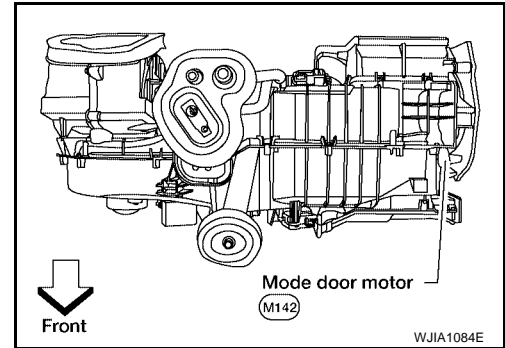

## DIAGNOSTIC PROCEDURE FOR MODE DOOR MOTOR

### 1. CHECK RESULT FROM FRONT AIR CONTROL SELF-DIAGNOSIS

Is self-diagnosis code 92 is present. Refer to [ATC-51, "A/C System Self-diagnosis Function"](#).

YES or NO

YES >> GO TO 2.

NO >> GO TO 3.

### 2. CHECK POWER SUPPLY AND GROUND CIRCUITS FOR MODE DOOR MOTOR

1. Turn ignition switch OFF.
2. Disconnect front air control connector and mode door motor connector.
3. Check continuity between front air control harness connector M49 terminal 1 and mode door motor harness connector M142 terminal 1 and between front air control harness connector M49 terminal 14 and mode door motor harness connector M142 terminal 6.

**1 - 1 : Continuity should exist.**

**14 - 6 : Continuity should exist.**

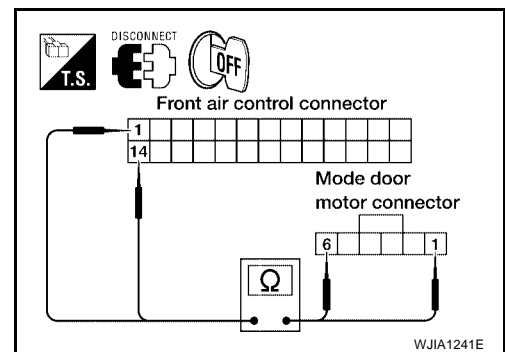

OK or NG

OK >> Replace mode door motor. Refer to [ATC-144, "MODE DOOR MOTOR"](#).

NG >> Repair or replace harness as necessary.

### 3. CHECK PBR REFERENCE SIGNAL VOLTAGE

1. Turn ignition switch OFF.
2. Disconnect the mode door motor connector.
3. Turn ignition switch ON.
4. Check voltage between mode door motor harness connector M142 terminal 3 and ground.

**3 - Ground : Approx. 5V**

OK or NG

OK >> GO TO 5.

NG >> GO TO 4.

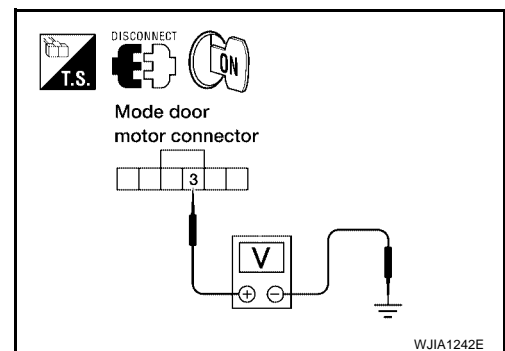

# TROUBLE DIAGNOSIS

## 4. CHECK PBR REFERENCE VOLTAGE CIRCUIT BETWEEN MODE DOOR AND FRONT AIR CONTROL

1. Turn ignition switch OFF.
2. Disconnect the front air control connector.
3. Check continuity between mode door motor harness connector M142 terminal 3 and front air control harness connector M49 terminal 23.

**3 - 23** : Continuity should exist.

OK or NG

OK >> Replace front air control. Refer to [ATC-127, "FRONT AIR CONTROL"](#).

NG >> Repair or replace harness as necessary.

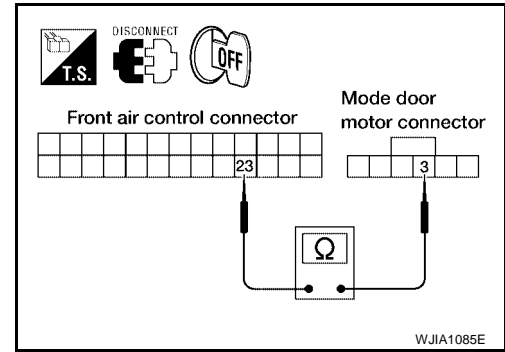

WJIA1085E

## 5. CHECK PBR GROUND REFERENCE CIRCUIT

1. Turn ignition switch OFF.
2. Disconnect the front air control connector.
3. Check continuity between mode door motor harness connector M142 terminal 2 and front air control harness connector M49 terminal 26.

**2 - 26** : Continuity should exist.

OK or NG

OK >> GO TO 6.

NG >> Repair or replace harness as necessary.

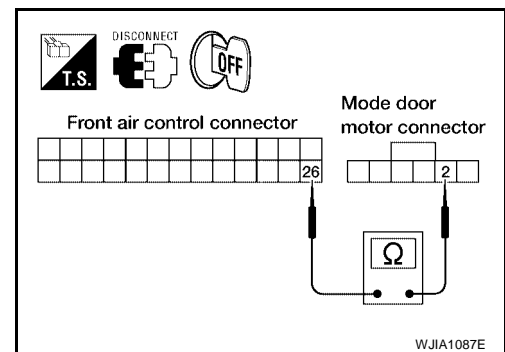

WJIA1087E

## 6. CHECK PBR FEEDBACK SIGNAL

1. Reconnect the front air control connector and mode door motor connector.
2. Turn ignition switch ON.
3. Check voltage between front air control harness connector M49 terminal 21 and ground.
4. Press mode switch through all modes.

**21 - Ground** : Approx. 0 - 5V

OK or NG

OK >> Replace front air control. Refer to [ATC-127, "FRONT AIR CONTROL"](#).

NG >> GO TO 7.

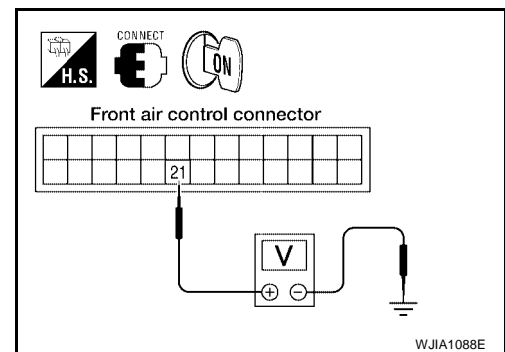

WJIA1088E

## 7. CHECK PBR FEEDBACK CIRCUIT

1. Turn ignition switch OFF.
2. Disconnect the mode door motor connector and front air control harness connector.
3. Check continuity between mode door motor harness connector M142 terminal 4 and front air control harness connector M49 terminal 21.

**4 - 21** : Continuity should exist.

OK or NG

OK >> Replace mode door motor. Refer to [ATC-144, "MODE DOOR MOTOR"](#).

NG >> Repair or replace harness as necessary.

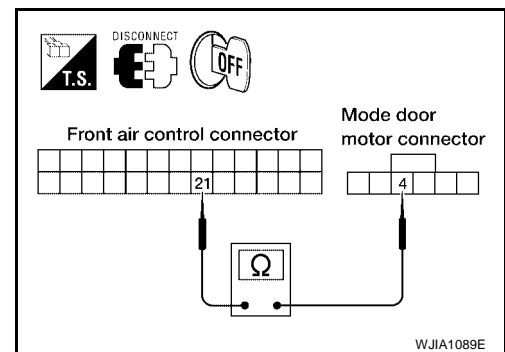

WJIA1089E

# TROUBLE DIAGNOSIS

EJS004P6

## Air Mix Door Motor Circuit

### SYMPTOM:

- Discharge air temperature does not change.
- Air mix door motor does not operate.

### INSPECTION FLOW

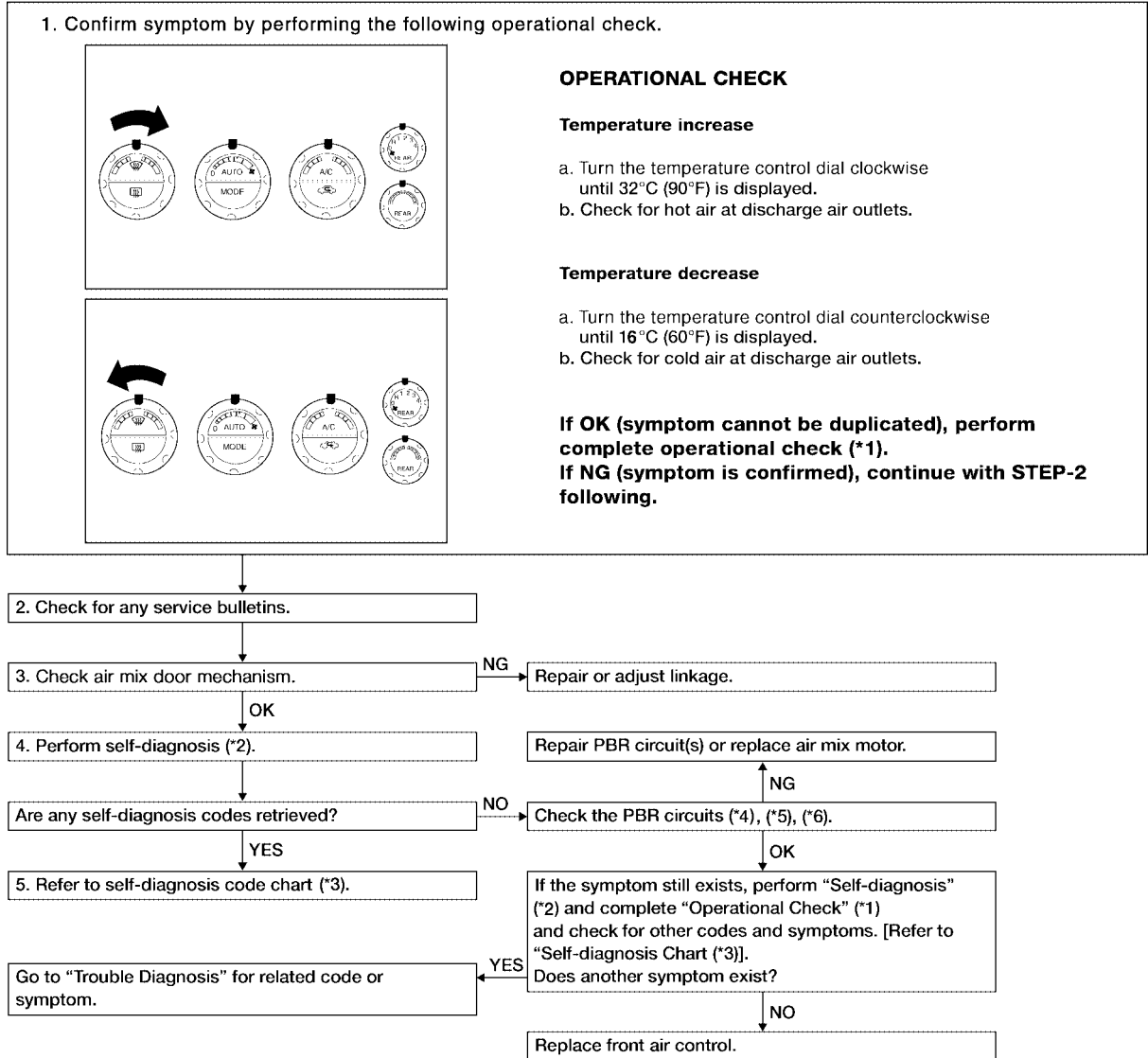

\*1 [ATC-53. "Operational Check \(Front\)"](#) or [ATC-55. "Operational Check \(Rear\)"](#)

\*4 [ATC-65. "DIAGNOSTIC PROCEDURE FOR AIR MIX DOOR MOTOR \(DRIVER\)"](#)

\*2 [ATC-51. "A/C System Self-diagnosis Function"](#)

\*5 [ATC-67. "DIAGNOSTIC PROCEDURE FOR AIR MIX DOOR MOTOR \(PASSENGER\)"](#)

\*3 [ATC-52. "SELF-DIAGNOSIS CODE CHART"](#)

\*6 [ATC-69. "DIAGNOSTIC PROCEDURE FOR AIR MIX DOOR MOTOR \(REAR\)"](#)

WJIA1462E

# TROUBLE DIAGNOSIS

## SYSTEM DESCRIPTION

### Component Parts

Air mix door control system components are:

- Front air control.
- Air mix door motors (driver, passenger, and rear)
- PBR (built into air mix door motors)
- In-vehicle sensor
- Ambient sensor
- Optical sensor
- Intake sensor

### System Operation

The front air control receives data from the temperature selected by the driver side, passenger side, and rear. The front air control then applies a voltage to one circuit of the appropriate air mix door motor, while ground is applied to the other circuit, causing the appropriate air mix door motor to rotate. The direction of rotation is determined by which circuit has voltage applied to it, and which one has ground applied to it. The front air control monitors the air mix door positions by measuring the voltage signal on the PBR circuits of each door.

In AUTO mode the air mix, intake, mode door, and defrost door positions are set by the front air control which determines the proper position based on inputs from the in-vehicle sensor, ambient sensor, optical sensor, intake sensor, and the temperature selected by the driver and front and rear passengers.

Subsequently, HOT/COLD or DEFROST/VENT or FRESH/RECIRCULATION operation is selected. The new door position data is returned to the front air control.

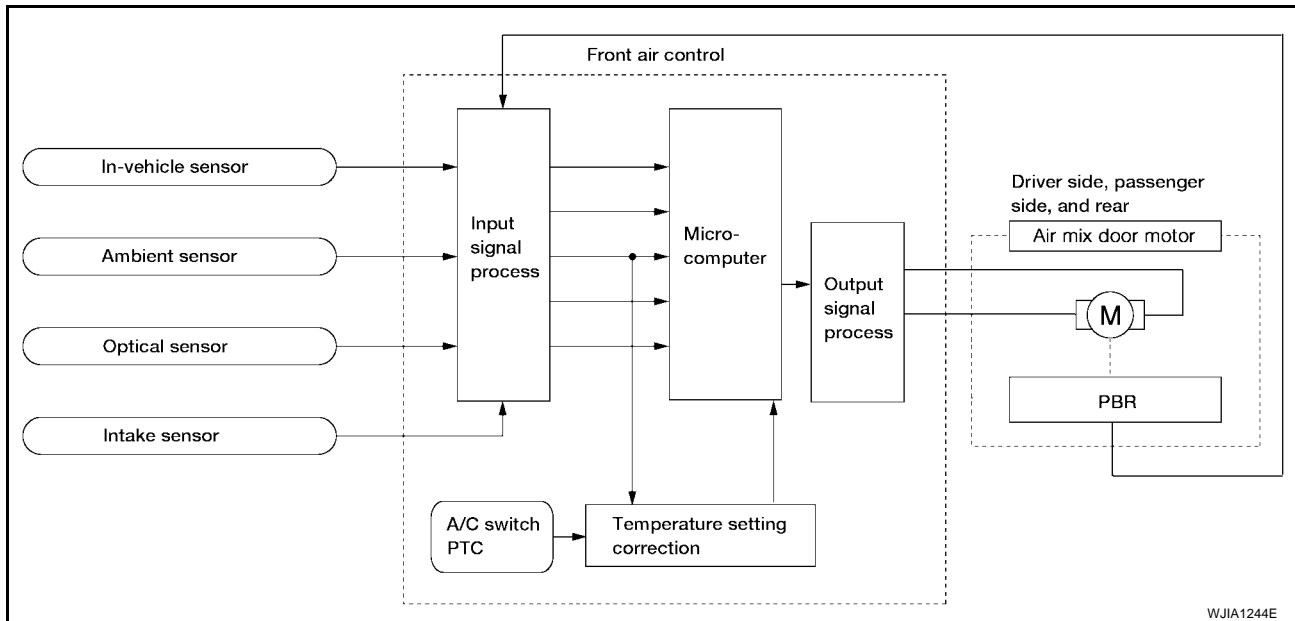

### Air Mix Door Control Specification

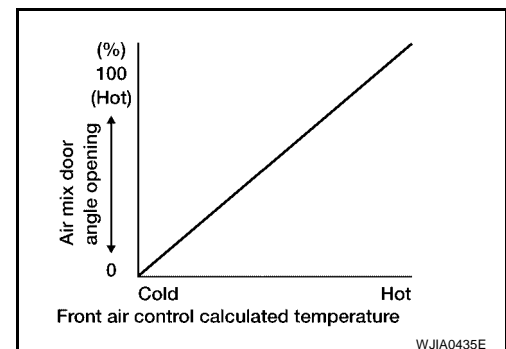



# TROUBLE DIAGNOSIS

## COMPONENT DESCRIPTION

### Air Mix Door Motors

The air mix door motor (passenger) (1) and the air mix door motor (driver) (2) are attached to the front heater & cooling unit assembly. The air mix door motor (rear) is attached to the rear heater & cooling unit assembly. These motors rotate so that the air mix door is opened or closed to a position set by the front (or rear) air control. Motor rotation is then conveyed through a shaft and the air mix door position is then fed back to the front air control by the PBR built into the air mix door motors.

←: Front

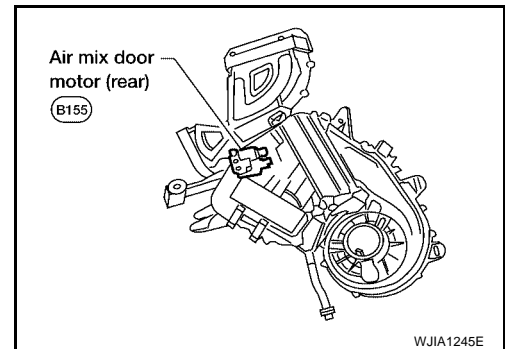
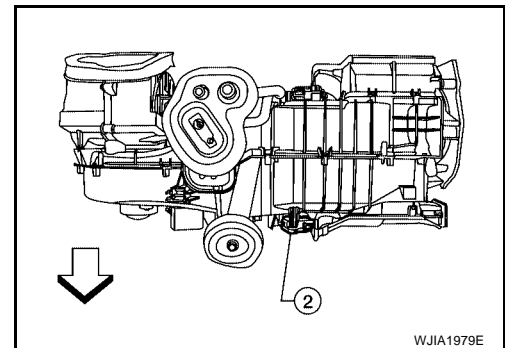
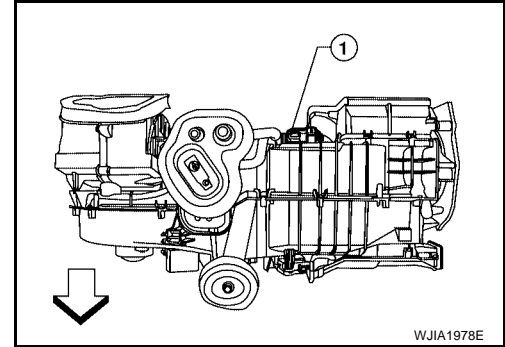

## DIAGNOSTIC PROCEDURE FOR AIR MIX DOOR MOTOR (DRIVER)

### 1. CHECK RESULT FROM FRONT AIR CONTROL SELF-DIAGNOSIS

Is self-diagnosis code 12 is present. Refer to [ATC-51, "A/C System Self-diagnosis Function"](#) .

YES or NO

YES >> GO TO 2.

NO >> GO TO 3.

A  
B  
C  
D  
E  
F  
G  
H  
I  
ATC  
K  
L  
M

# TROUBLE DIAGNOSIS

## 2. CHECK POWER SUPPLY CIRCUITS FOR AIR MIX DOOR MOTOR (DRIVER)

1. Turn ignition switch OFF.
2. Disconnect front air control connector and air mix door motor (driver) connector.
3. Check continuity between front air control harness connector M49 terminal 2 and 3 and air mix door motor (driver) harness connector M147 terminal 5 and 6.

**2 - 5 : Continuity should exist.**

**3 - 6 : Continuity should exist.**

OK or NG

OK >> Replace air mix door motor (driver). Refer to [ATC-145](#), "[FRONT AIR MIX DOOR MOTOR \(DRIVER\)](#)".

NG >> Repair or replace harness as necessary.

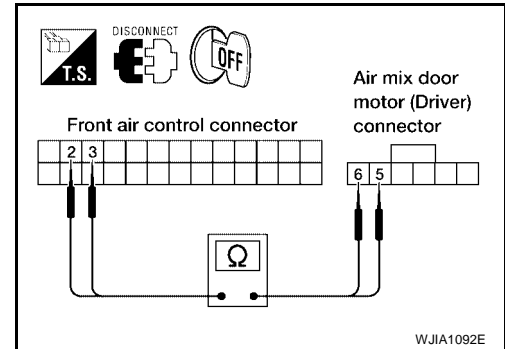

## 3. CHECK PBR REFERENCE SIGNAL VOLTAGE

1. Turn ignition switch OFF.
2. Disconnect the air mix door motor (driver) connector.
3. Turn ignition switch ON.
4. Check voltage between air mix door motor (driver) harness connector M147 terminal 3 and ground.

**3 - Ground : Approx. 5V**

OK or NG

OK >> GO TO 5.

NG >> GO TO 4.

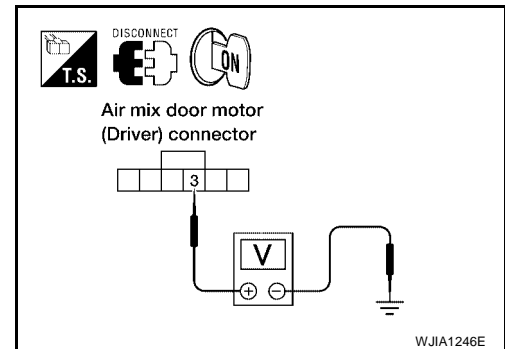

## 4. CHECK PBR REFERENCE VOLTAGE CIRCUIT BETWEEN AIR MIX DOOR MOTOR (DRIVER) AND FRONT AIR CONTROL

1. Turn ignition switch OFF.
2. Disconnect the front air control connector.
3. Check continuity between air mix door motor (driver) harness connector M147 terminal 3 and front air control harness connector M49 terminal 23.

**3 - 23 : Continuity should exist.**

OK or NG

OK >> Replace front air control. Refer to [ATC-127](#), "[FRONT AIR CONTROL](#)".

NG >> Repair or replace harness as necessary.

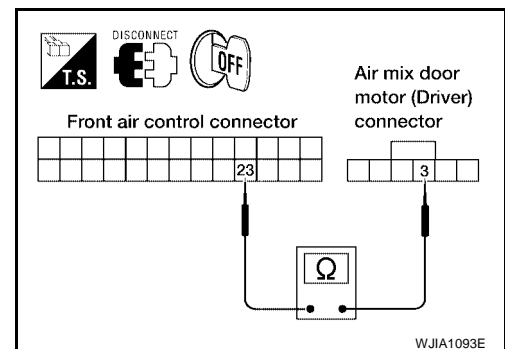

## 5. CHECK PBR GROUND REFERENCE CIRCUIT

1. Turn ignition switch OFF.
2. Disconnect the front air control connector.
3. Check continuity between air mix door motor (driver) harness connector M147 terminal 1 and front air control harness connector M49 terminal 26.

**1 - 26 : Continuity should exist.**

OK or NG

OK >> GO TO 6.

NG >> Repair or replace harness as necessary.

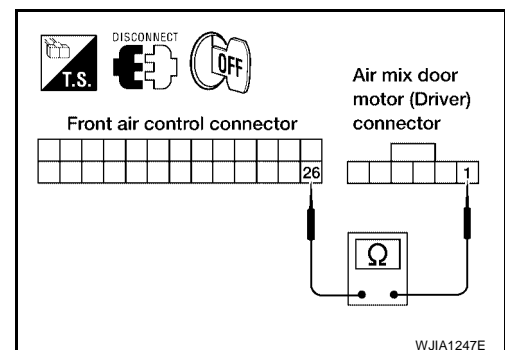

# TROUBLE DIAGNOSIS

## 6. CHECK PBR FEEDBACK SIGNAL

1. Reconnect the front air control connector and air mix door motor (driver) connector.
2. Turn ignition switch ON.
3. Check voltage between front air control harness connector M49 terminal 22 and ground.
4. Rotate driver temperature control dial through complete range.

**22 - Ground : Approx. 0V - 5V**

OK or NG

- OK >> Replace front air control. Refer to [ATC-127, "FRONT AIR CONTROL"](#).
- NG >> GO TO 7.

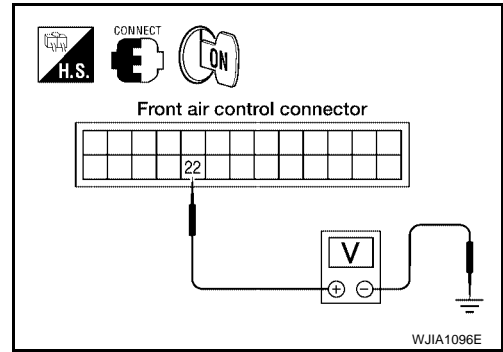

## 7. CHECK PBR FEEDBACK CIRCUIT

1. Turn ignition switch OFF.
2. Disconnect the air mix door motor (driver) connector and front air control connector.
3. Check continuity between air mix door motor (driver) harness connector M147 terminal 2 and front air control harness connector M49 terminal 22.

**2 - 22 Continuity should exist.**

OK or NG

- OK >> Replace air mix door motor (driver). Refer to [ATC-145, "FRONT AIR MIX DOOR MOTOR \(DRIVER\)"](#).
- NG >> Repair or replace harness as necessary.

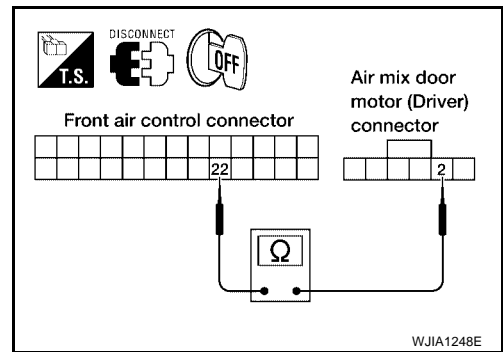

## DIAGNOSTIC PROCEDURE FOR AIR MIX DOOR MOTOR (PASSENGER)

### 1. CHECK RESULT FROM FRONT AIR CONTROL SELF-DIAGNOSIS

Self-diagnosis code 22 is present. Refer to [ATC-51, "A/C System Self-diagnosis Function"](#).

YES or NO

- YES >> GO TO 2.
- NO >> GO TO 3.

### 2. CHECK POWER SUPPLY CIRCUIT FOR AIR MIX DOOR MOTOR (PASSENGER)

1. Turn ignition switch OFF.
2. Disconnect front air control connector and air mix door motor (passenger) connector.
3. Check continuity between front air control harness connector M49 terminal 15 and 16 and air mix door motor (passenger) harness connector M143 terminal 6 and 5.

**15 - 6 Continuity should exist.**

**16 - 5 Continuity should exist.**

OK or NG

- OK >> Replace air mix door motor (passenger). Refer to [ATC-145, "FRONT AIR MIX DOOR MOTOR \(PASSENGER\)"](#).
- NG >> Repair or replace harness as necessary.

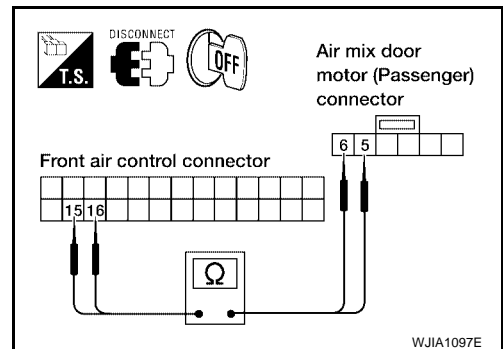

# TROUBLE DIAGNOSIS

## 3. CHECK PBR REFERENCE SIGNAL VOLTAGE

1. Turn ignition switch OFF.
2. Disconnect the air mix door motor (passenger) connector.
3. Turn ignition switch ON.
4. Check voltage between air mix door motor (passenger) harness connector M143 terminal 1 and ground.

Terminals		Condition	Voltage (Approx.)
(+)	(-)		
Air mix door motor (passenger) connector	Terminal No.		
M143	1	Ground	5V

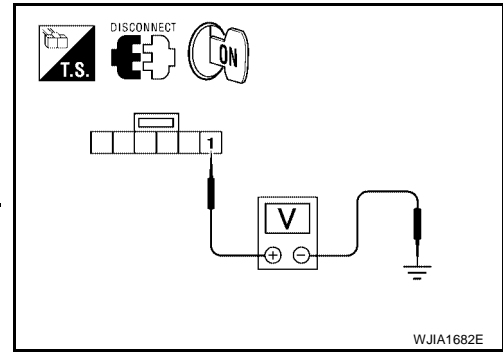

**OK or NG**

- OK >> GO TO 5.  
 NG >> GO TO 4.

## 4. CHECK PBR REFERENCE VOLTAGE CIRCUIT BETWEEN AIR MIX DOOR (PASSENGER) AND FRONT AIR CONTROL

1. Turn ignition switch OFF.
2. Disconnect the front air control connector.
3. Check continuity between air mix door motor (passenger) harness connector M143 (B) terminal 1 and front air control harness connector M49 (A) terminal 23.

A		B		Continuity
Connector	Terminal	Connector	Terminal	
Front air control: M49	23	Air mix door motor (passenger): M143	1	Yes

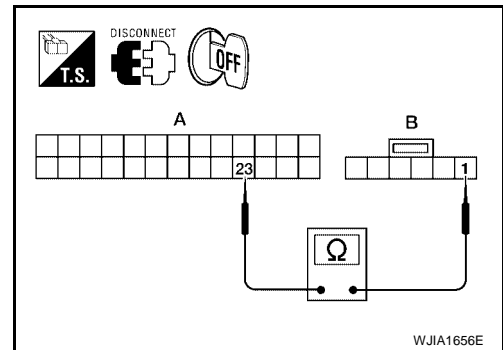

**OK or NG**

- OK >> Replace front air control. Refer to [ATC-127, "FRONT AIR CONTROL"](#).  
 NG >> Repair or replace harness as necessary.

## 5. CHECK PBR GROUND REFERENCE CIRCUIT

1. Turn ignition switch OFF.
2. Disconnect the front air control connector.
3. Check continuity between air mix door motor (passenger) harness connector M143 (B) terminal 3 and front air control harness connector M49 (A) terminal 26.

A		B		Continuity
Connector	Terminal	Connector	Terminal	
Front air control: M49	26	Air mix door motor (passenger): M143	3	Yes

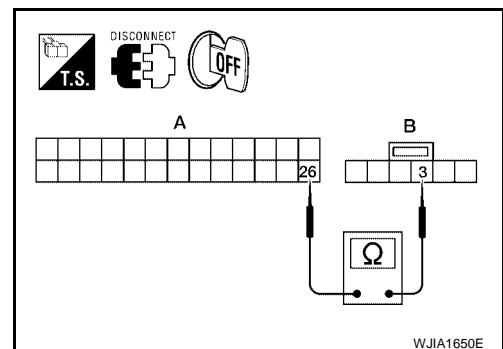

**OK or NG**

- OK >> GO TO 6.  
 NG >> Repair or replace harness as necessary.

# TROUBLE DIAGNOSIS

## 6. CHECK PBR FEEDBACK SIGNAL

1. Reconnect the front air control connector and air mix door motor (passenger) connector.
2. Turn ignition switch ON.
3. Check voltage between front air control harness connector M50 terminal 36 and ground.
4. Rotate passenger temperature control dial through complete range.

**36 - Ground : Approx. 0 - 5V**

OK or NG

- OK >> Replace front air control. Refer to [ATC-127, "FRONT AIR CONTROL"](#).
- NG >> GO TO 7.

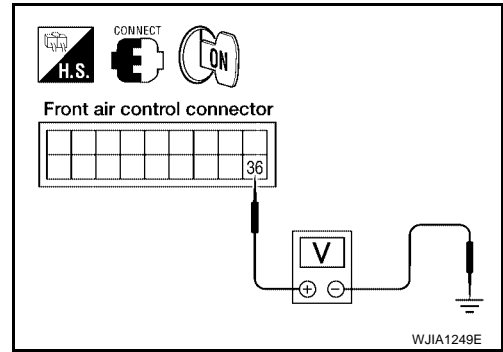

## 7. CHECK PBR FEEDBACK CIRCUIT

1. Turn ignition switch OFF.
2. Disconnect the air mix door motor (passenger) connector and front air control connector.
3. Check continuity between air mix door motor (passenger) harness connector M143 terminal 2 and front air control harness connector M50 terminal 36.

**2 - 36 : Continuity should exist.**

OK or NG

- OK >> Replace air mix door motor (passenger). Refer to [ATC-145, "FRONT AIR MIX DOOR MOTOR \(PASSENGER\)"](#).
- NG >> Repair or replace harness as necessary.

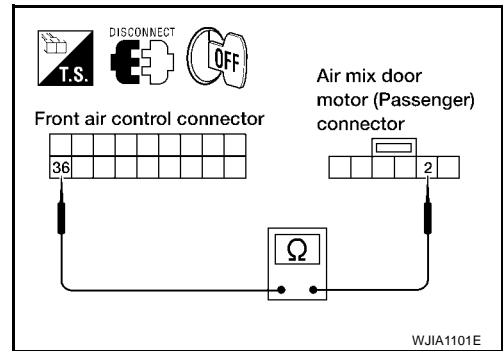

## DIAGNOSTIC PROCEDURE FOR AIR MIX DOOR MOTOR (REAR)

### 1. CHECK RESULT FROM FRONT AIR CONTROL SELF-DIAGNOSIS

If self-diagnosis code 38 is present. Refer to [ATC-51, "A/C System Self-diagnosis Function"](#).

YES or NO

- YES >> GO TO 2.
- NO >> GO TO 3.

### 2. CHECK POWER SUPPLY CIRCUIT FOR AIR MIX DOOR MOTOR (REAR)

1. Turn ignition switch OFF.
2. Disconnect front air control connector and air mix door motor (rear) connector.
3. Check continuity between front air control harness connector M49 terminal 17 and air mix door motor (rear) harness connector B155 terminal 6 and between front air control harness connector M49 terminal 18 and air mix door motor (rear) harness connector B155 terminal 1.

**17 - 6 Continuity should exist.**

**18 - 1 Continuity should exist.**

OK or NG

- OK >> Replace air mix door motor (rear). Refer to [ATC-146, "REAR AIR MIX DOOR MOTOR"](#).
- NG >> Repair or replace harness as necessary.

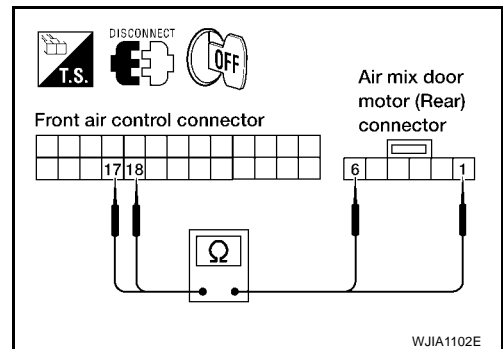

# TROUBLE DIAGNOSIS

## 3. CHECK PBR REFERENCE SIGNAL VOLTAGE

1. Turn ignition switch OFF.
2. Disconnect the air mix door motor (rear) connector.
3. Turn ignition switch ON.
4. Check voltage between air mix door motor (rear) harness connector B155 terminal 3 and ground.

**3 - Ground : Approx. 5V**

OK or NG

- OK >> GO TO 5.  
NG >> GO TO 4.

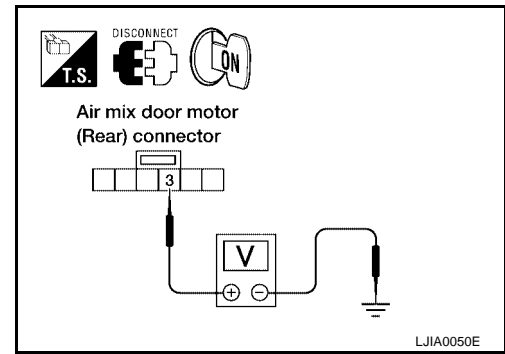

## 4. CHECK PBR REFERENCE VOLTAGE CIRCUIT BETWEEN AIR MIX DOOR MOTOR (REAR) AND FRONT AIR CONTROL

1. Turn ignition switch OFF.
2. Disconnect the front air control connector.
3. Check continuity between air mix door motor (rear) harness connector B155 terminal 3 and front air control harness connector M49 terminal 23.

**3 - 23 Continuity should exist.**

OK or NG

- OK >> Replace front air control. Refer to [ATC-127, "FRONT AIR CONTROL"](#).  
NG >> Repair or replace harness as necessary.

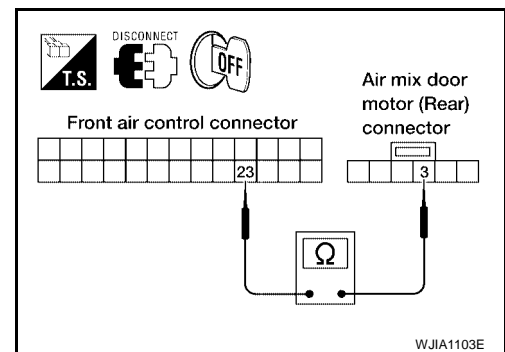

## 5. CHECK PBR GROUND REFERENCE CIRCUIT

1. Turn ignition switch OFF.
2. Disconnect the front air control connector.
3. Check continuity between air mix door motor (rear) harness connector B155 terminal 2 and front air control harness connector M49 terminal 26.

**2 - 26 Continuity should exist.**

OK or NG

- OK >> GO TO 6.  
NG >> Repair or replace harness as necessary.

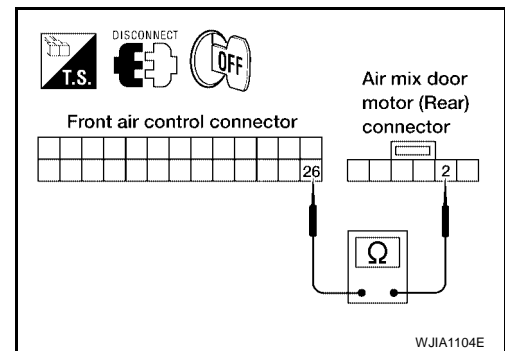

## 6. CHECK PBR FEEDBACK SIGNAL

1. Reconnect the front air control connector and air mix door motor (rear) connector.
2. Turn ignition switch ON.
3. Check voltage between front air control harness connector M49 terminal 25 and ground.
4. Rotate rear temperature and mode control dial through complete range.

**25 - Ground : Approx. 0 - 5V**

OK or NG

- OK >> Replace front air control. Refer to [ATC-127, "FRONT AIR CONTROL"](#).  
NG >> GO TO 7.

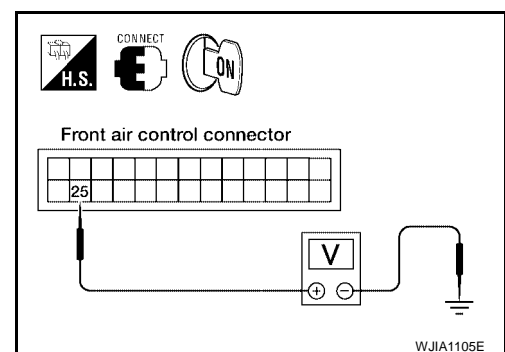

# TROUBLE DIAGNOSIS

## 7. CHECK PBR FEEDBACK CIRCUIT

1. Turn ignition switch OFF.
2. Disconnect the air mix door motor (rear) connector and front air control connector.
3. Check continuity between air mix door motor (rear) harness connector B155 terminal 4 and front air control harness connector M49 terminal 25.

**4 - 25**

**Continuity should exist.**

OK or NG

- OK >> Replace air mix door motor (rear). Refer to [ATC-146](#), "[REAR AIR MIX DOOR MOTOR](#)".
- NG >> Repair or replace harness as necessary.

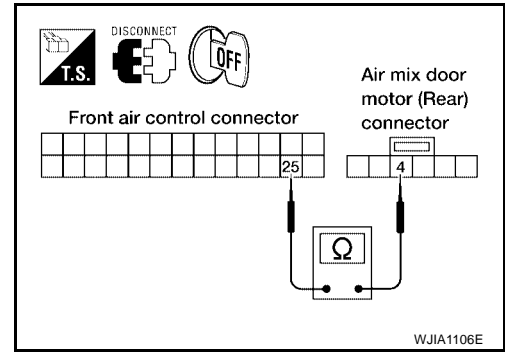

A  
B  
C  
D  
E  
F  
G  
H  
I  
K  
L  
M

ATC

# TROUBLE DIAGNOSIS

EJS004P7

## Intake Door Motor Circuit

### SYMPTOM:

- Intake door does not change.
- Intake door motor does not operate normally.

### INSPECTION FLOW

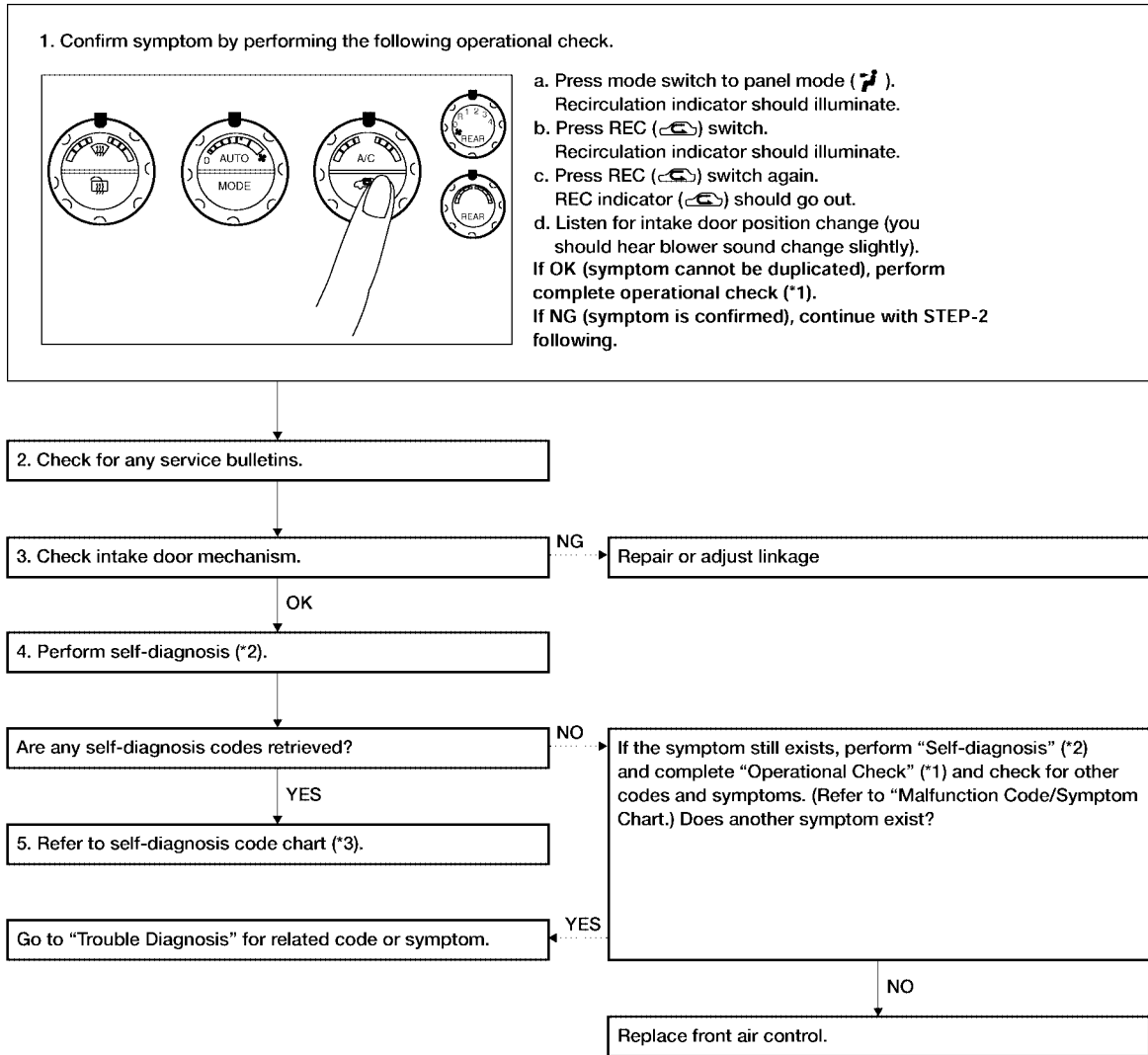

\*1 [ATC-53. "Operational Check \(Front\)"](#)

\*2 [ATC-51. "A/C System Self-diagnosis Function"](#)

\*3 [ATC-52. "SELF-DIAGNOSIS CODE CHART"](#)

WJIA1053E



# TROUBLE DIAGNOSIS

## SYSTEM DESCRIPTION

### Component Parts

Intake door control system components are:

- Front air control
- Intake door motor
- In-vehicle sensor
- Ambient sensor
- Optical sensor
- Intake sensor

### System Operation

The intake door control determines the intake door position based on the position of the recirculation switch. When the recirculation switch is depressed the intake door motor rotates closing off the fresh air inlet and recirculating the cabin air. If the recirculation switch is depressed again, the intake door motor rotates in the opposite direction, again allowing fresh air into the cabin.

In the AUTO mode, the front air control determines the intake door position based on the ambient temperature, the intake air temperature and the in-vehicle temperature. When the DEFROST, or OFF switches are pushed or A/C switch is OFF, the front air control sets the intake door at the fresh position.

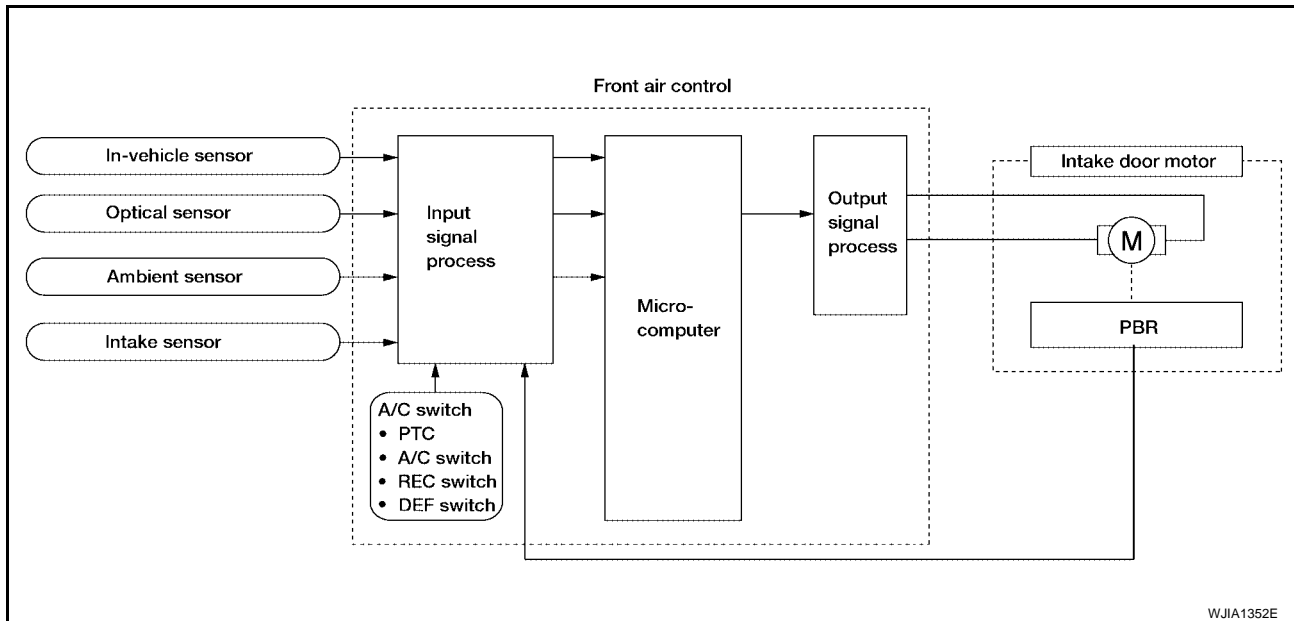

### Intake Door Control Specification

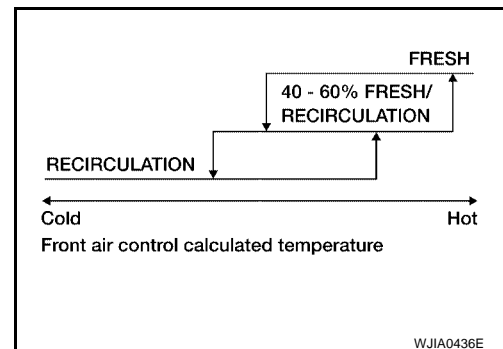

# TROUBLE DIAGNOSIS

## COMPONENT DESCRIPTION

### Intake door motor

The intake door motor is attached to the intake unit. It rotates so that air is drawn from inlets set by the front air control. Motor rotation is conveyed to a lever which activates the intake door.

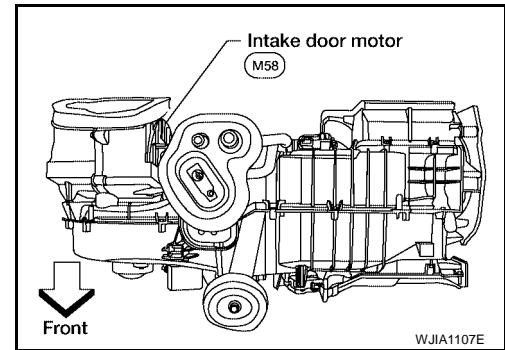

## DIAGNOSTIC PROCEDURE FOR INTAKE DOOR MOTOR

### 1. CHECK RESULT FROM FRONT AIR CONTROL SELF-DIAGNOSIS

Is self-diagnosis code 82 present? Refer to [ATC-51, "A/C System Self-diagnosis Function"](#) .

YES or NO

YES >> GO TO 2.

NO >> Replace front air control. Refer to [ATC-127, "FRONT AIR CONTROL"](#) .

### 2. CHECK POWER SUPPLY CIRCUIT FOR INTAKE DOOR MOTOR

1. Turn ignition switch OFF.
2. Disconnect front air control connector and intake door motor connector.
3. Check continuity between front air control harness connector M49 terminal 5 and intake door motor harness connector M58 terminal 6 and between front air control harness connector M49 terminal 4 and intake door motor harness connector M58 terminal 1.

**5 - 6**

**Continuity should exist.**

**4 - 1**

**Continuity should exist.**

OK or NG

OK >> Replace intake door motor. Refer to [ATC-143, "INTAKE DOOR MOTOR"](#) .

NG >> Repair or replace harness as necessary.

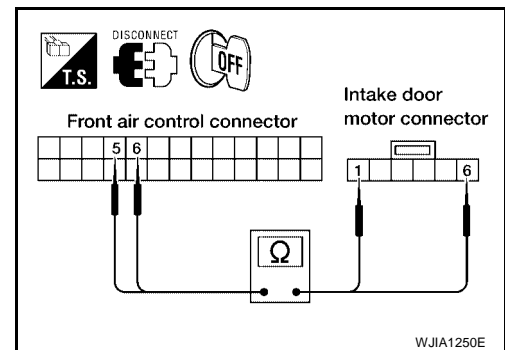

# TROUBLE DIAGNOSIS

EJS004P8

## Front Blower Motor Circuit

SYMPTOM:

- Blower motor operation is malfunctioning.

### INSPECTION FLOW

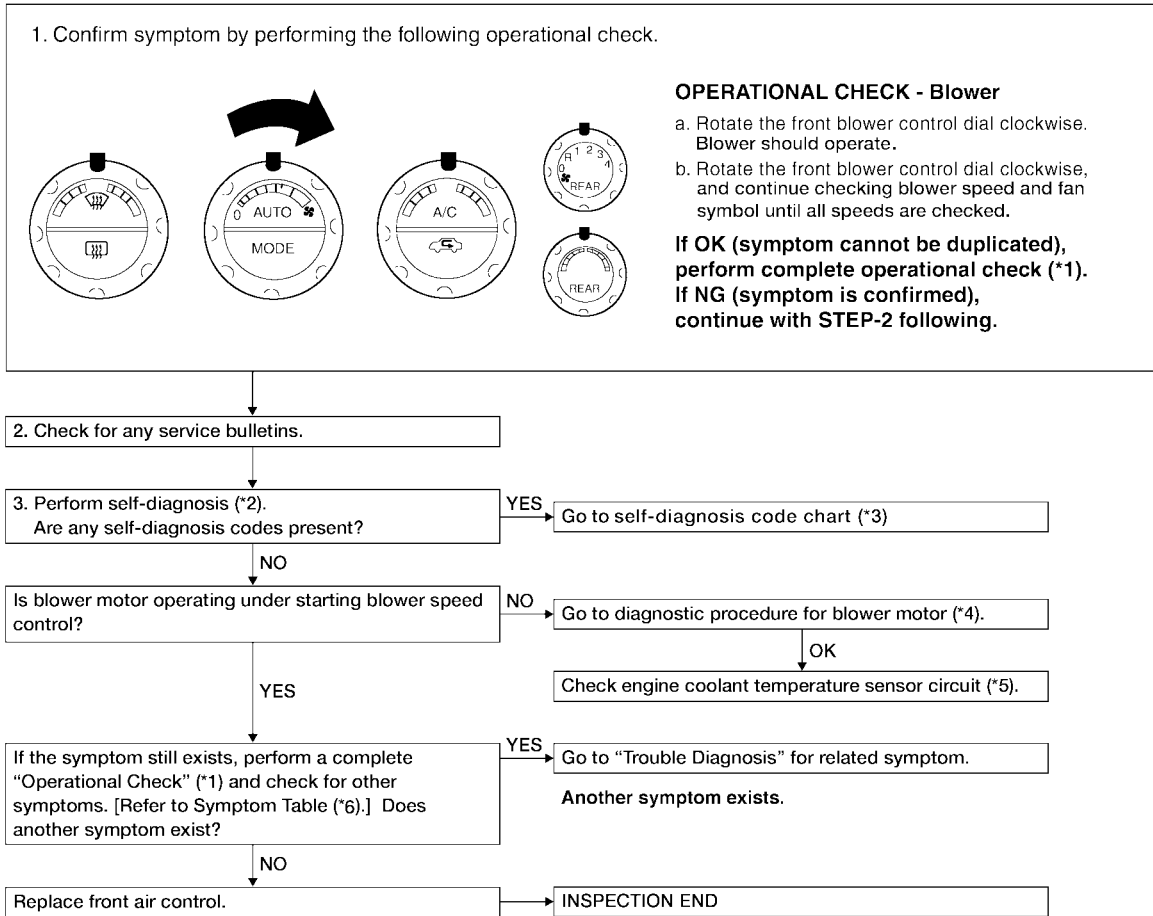

\*1 [.ATC-53. "Operational Check \(Front\)"](#)

\*4 [ATC-77. "DIAGNOSTIC PROCEDURE FOR BLOWER MOTOR"](#)

\*2 [ATC-51. "A/C System Self-diagnosis Function"](#)

\*5 [EC-207. "DTC P0117, P0118 ECT SENSOR"](#)

\*3 [ATC-52. "SELF-DIAGNOSIS CODE CHART"](#)

\*6 [ATC-36. "SYMPTOM TABLE"](#)

WJIA1251E

# TROUBLE DIAGNOSIS

## SYSTEM DESCRIPTION

### Component Parts

Blower speed control system components are:

- Front air control
- Front blower motor relay
- Front blower motor
- Variable blower control
- In-vehicle sensor
- Ambient sensor
- Optical sensor
- Intake sensor

### System Operation

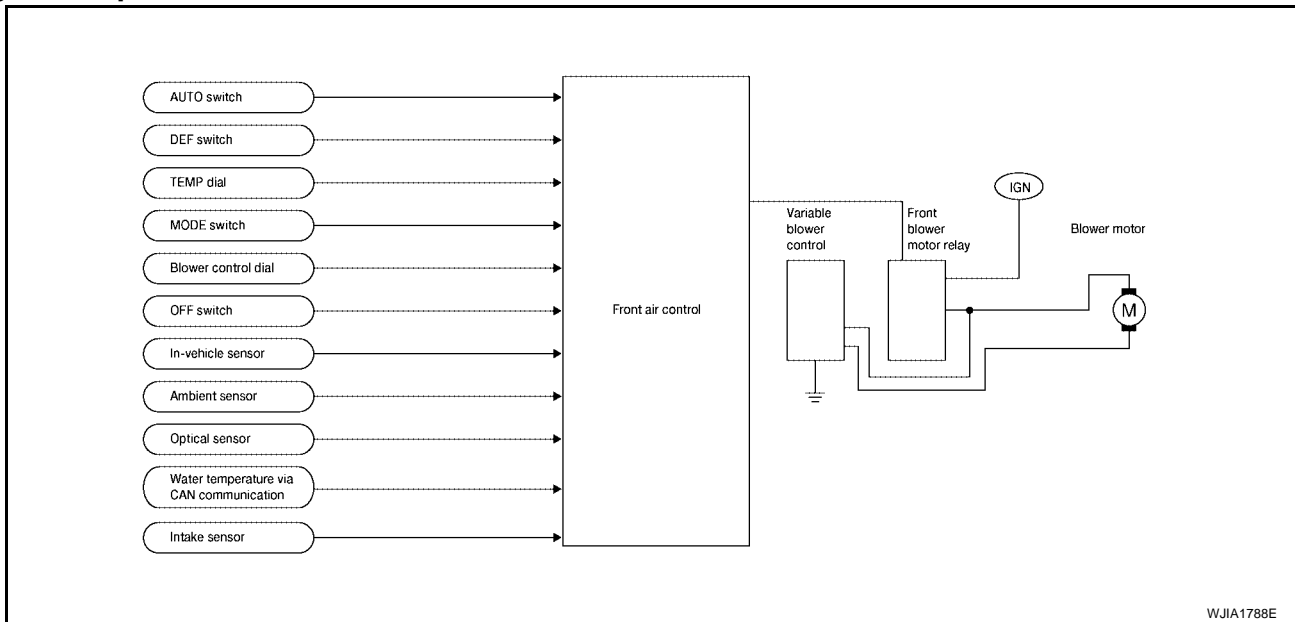

### Automatic Mode

In the automatic mode, the blower motor speed is calculated by the front air control and variable blower control based on input from the in-vehicle sensor, optical sensor, intake sensor and ambient sensor, and potentiometer control (PTC).

When the air flow is increased, the blower motor speed is adjusted gradually to prevent a sudden increase in air flow.

In addition to manual air flow control and the usual automatic air flow control, starting air flow control, low water temperature starting control and high passenger compartment temperature starting control are available.

### Starting Blower Speed Control

Start up from cold soak condition (Automatic mode).

In a cold start up condition where the engine coolant temperature is below 50°C (122°F), the blower will not operate at blower speed 1 for a short period of time (up to 210 seconds). The exact start delay time varies depending on the ambient and engine coolant temperatures.

In the most extreme case (very low ambient temperature) the blower starting delay will be 210 seconds as described above. After the coolant temperature reaches 50°C (122°F), or the 210 seconds has elapsed, the blower speed will increase to the objective blower speed.

Start up from usual operating or hot soak condition (Automatic mode).

The blower will begin operation momentarily after the AUTO switch is pushed. The blower speed will gradually rise to the objective speed over a time period of 3 seconds or less (actual time depends on the objective blower speed).

# TROUBLE DIAGNOSIS

## Blower Speed Compensation - Sunload

When the in-vehicle temperature and the set temperature are very close, the blower will be operating at low speed. The speed will vary depending on the sunload. During conditions of low or no sunload, the blower operates at low speed. During high sunload conditions, the front air control causes the blower speed to increase.

## Blower Speed Control Specification

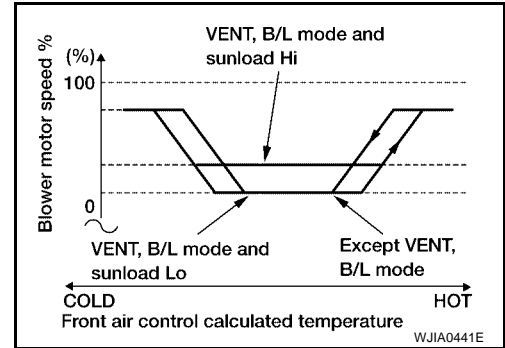

## COMPONENT DESCRIPTION

### Variable Blower Control

The variable blower control is located on the cooling unit. The variable blower control receives a gate voltage from the front air control to steplessly maintain the blower motor voltage in the 0 to 5 volt range (approx.).

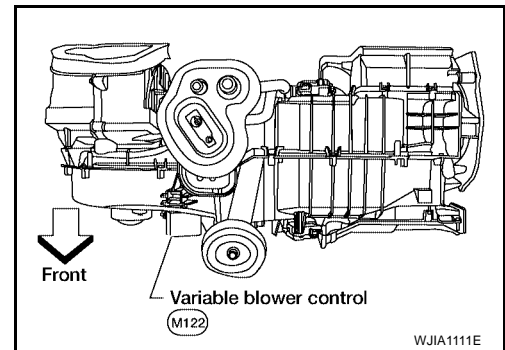

## DIAGNOSTIC PROCEDURE FOR BLOWER MOTOR

**SYMPTOM:** Blower motor operation is malfunctioning under starting blower speed control.

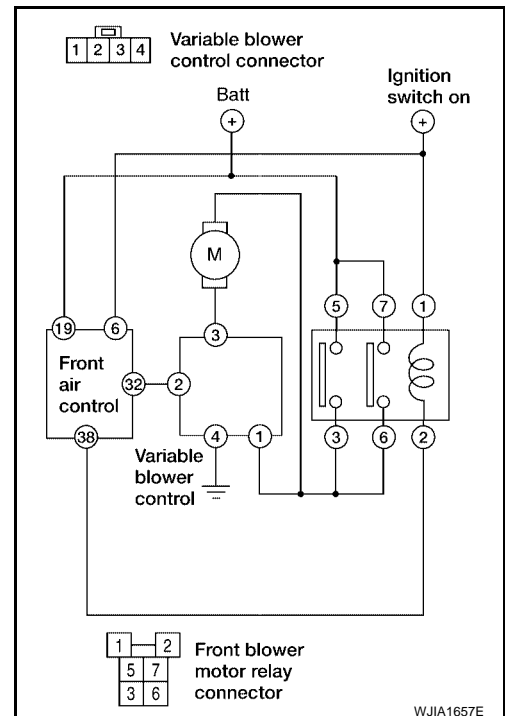

# TROUBLE DIAGNOSIS

## 1. CHECK FUSES

Check 15A fuses [No. 24 and 27, (located in the fuse and fusible link box)]. For fuse layout, refer to [PG-84, "FUSE AND FUSIBLE LINK BOX"](#) .

**Fuses are good.**

OK or NG

- OK >> GO TO 2.
- NG >> GO TO 10.

## 2. CHECK FRONT BLOWER MOTOR POWER SUPPLY CIRCUIT

1. Turn ignition switch OFF.
2. Disconnect front blower motor connector.
3. Turn ignition switch ON.
4. Turn the front blower control dial to select any mode except off.
5. Check voltage between front blower motor harness connector M62 terminal 1 and ground.

**1 - Ground : Battery voltage**

OK or NG

- OK >> GO TO 12.
- NG >> GO TO 3.

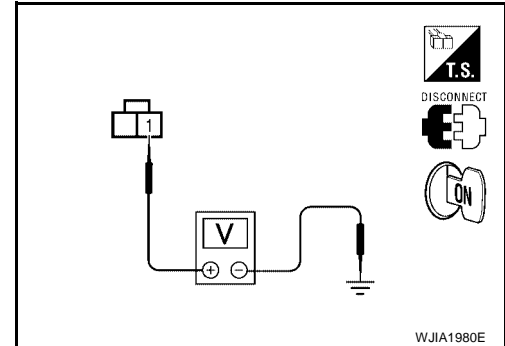

## 3. CHECK FRONT BLOWER MOTOR RELAY (SWITCH SIDE) POWER SUPPLY CIRCUIT

1. Turn ignition switch OFF.
2. Disconnect front blower motor relay.
3. Check voltage between front blower motor relay harness connector E22 terminals 5 and 7 and ground.

A				
Connector	(+)	(-)	Condition	Voltage (Approx.)
Front blower motor relay: E22	5	Ground	Front blower motor relay power supply	Battery voltage
Front blower motor relay: E22	7		Front blower motor relay power supply	Battery Voltage

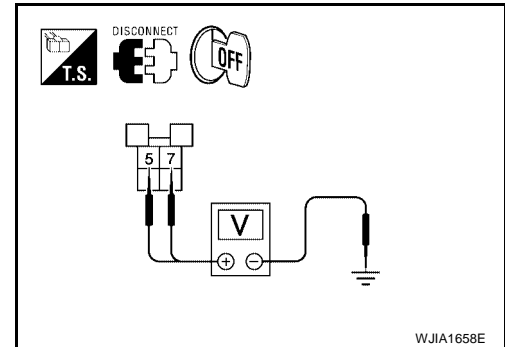

OK or NG

- OK >> GO TO 4.
- NG >> Repair harness or connector.

## 4. CHECK FRONT BLOWER MOTOR RELAY

Refer to [ATC-81, "Front Blower Motor Relay"](#) .

OK or NG

- OK >> GO TO 5.
- NG >> Replace front blower motor relay.

# TROUBLE DIAGNOSIS

## 5. CHECK FRONT BLOWER MOTOR RELAY (SWITCH SIDE) CIRCUIT FOR OPEN

1. Turn ignition switch OFF.
2. Disconnect blower motor relay connector and front blower motor connector.
3. Check continuity between front blower motor relay harness connector E22 (A) terminals 3 and 6 and front blower motor harness connector M62 (B) terminal 1.

A		B		Continuity
Connector	Terminal	Connector	Terminal	
Front blower motor relay: E22	3	Front blower motor: M62	1	Yes
Front blower motor relay: E22	6	Front blower motor: M62	1	Yes

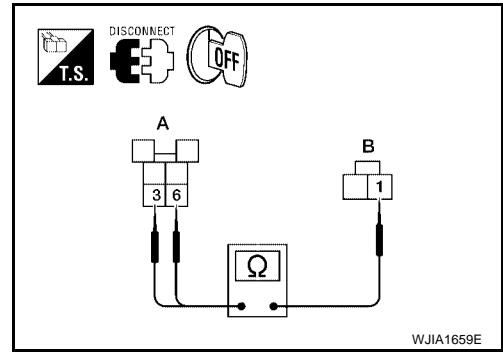

OK or NG

- OK >> GO TO 6.
- NG >> Repair harness or connector.

## 6. CHECK VARIABLE BLOWER CONTROL POWER SUPPLY CIRCUIT FOR OPEN

1. Disconnect variable blower control harness connector.
2. Check continuity between front blower motor relay harness connector E22 (A) terminals 3 and 6 and variable blower control harness connector M122 (B) terminal 1.

A		B		Continuity
Connector	Terminal	Connector	Terminal	
Front blower motor relay: E22	3	Variable blower control: M122	1	Yes
Front blower motor relay: E22	6	Front blower motor: M122	1	Yes

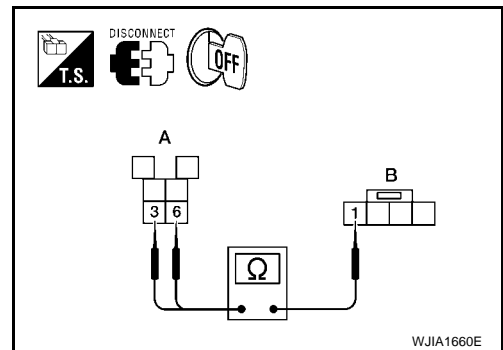

OK or NG

- OK >> GO TO 7.
- NG >> Repair harness or connector.

## 7. CHECK VARIABLE BLOWER CONTROL SIGNAL CIRCUIT

1. Disconnect front air control connector.
2. Check continuity between front air control harness connector M50 terminal 32 and variable blower control harness connector M122 terminal 2.

**32 - 2 : Continuity should exist.**

OK or NG

- OK >> GO TO 8.
- NG >> Repair harness or connector.

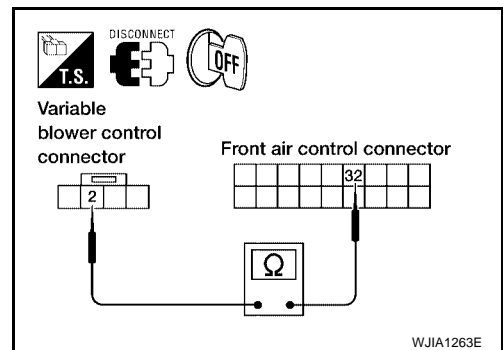

# TROUBLE DIAGNOSIS

## 8. CHECK FRONT BLOWER MOTOR RELAY (COIL SIDE) POWER SUPPLY

1. Turn ignition switch ON.
2. Check voltage between front blower motor relay connector E22 terminal 1 and ground.

**1 - Ground** : **Battery voltage**

OK or NG

- OK >> GO TO 9.  
NG >> Repair harness or connector.

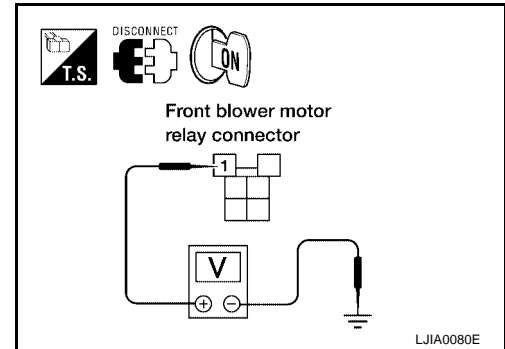

## 9. CHECK FRONT BLOWER MOTOR RELAY (COIL SIDE) GROUND CIRCUIT

1. Turn ignition switch OFF.
2. Check continuity between front blower motor relay connector E22 terminal 2 and front air control harness connector M50 terminal 38.

**2 - 38** : **Continuity should exist.**

OK or NG

- OK >> Replace front air control. Refer to [ATC-127, "FRONT AIR CONTROL"](#) .  
NG >> Repair harness or connector.

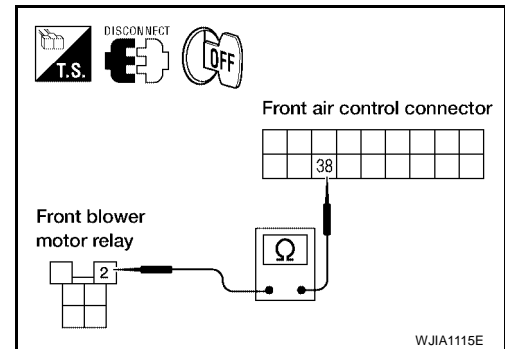

## 10. REPLACE FUSES

1. Replace fuses.
2. Activate the front blower motor.
3. Do fuses blow?

YES or NO

- YES >> GO TO 11.  
NO >> Inspection End.

## 11. CHECK FRONT BLOWER MOTOR POWER SUPPLY CIRCUIT FOR SHORT

1. Turn ignition switch OFF.
2. Disconnect front blower motor connector and variable blower control connector.
3. Check continuity between variable blower control harness connector M122 terminal 1 and ground.

**1 - Ground** : **Continuity should not exist.**

OK or NG

- OK >> GO TO 12.  
NG >> Repair harness or connector.

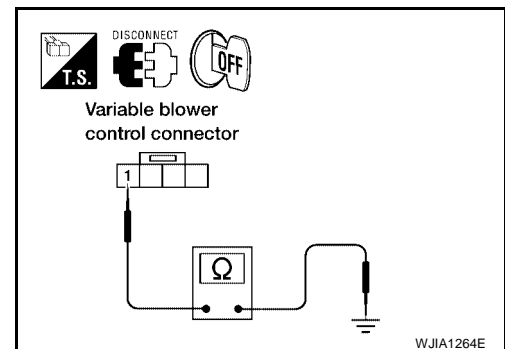



# TROUBLE DIAGNOSIS

## 12. CHECK VARIABLE BLOWER CONTROL SIGNAL CIRCUIT

1. Disconnect front air control connector.
2. Check continuity between front air control harness connector M50 terminal 32 and variable blower control harness connector M122 terminal 2.

**32 - 2 : Continuity should exist.**

OK or NG

- OK >> Check blower motor. If OK, replace variable blower control. Refer to [ATC-81, "Front Blower Motor"](#) .
- NG >> Repair harness or connector.

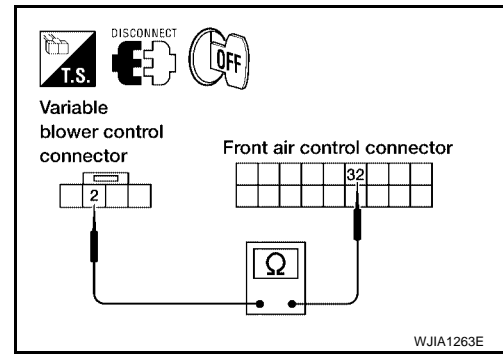

### COMPONENT INSPECTION

#### Front Blower Motor Relay

Check continuity between terminals by supplying 12 volts and ground to coil side terminals of relay.

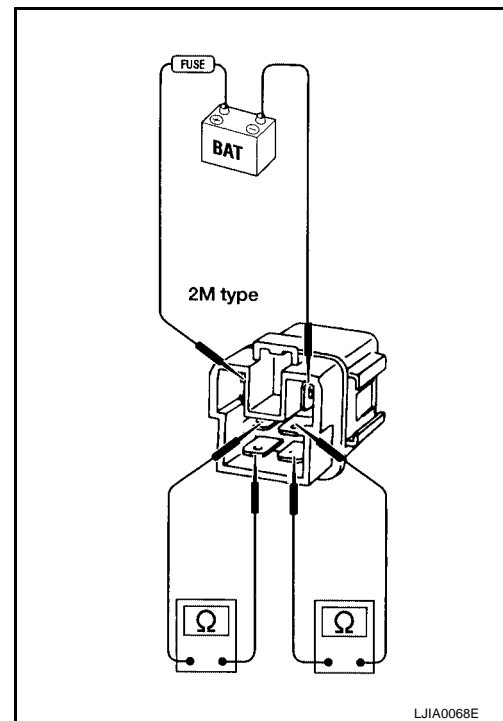

#### Front Blower Motor

Confirm smooth rotation of the blower motor.

- Ensure that there are no foreign particles inside the blower unit.
- Apply 12 volts to terminal 1 and ground to terminal 2 and verify that the motor operates freely and quietly.

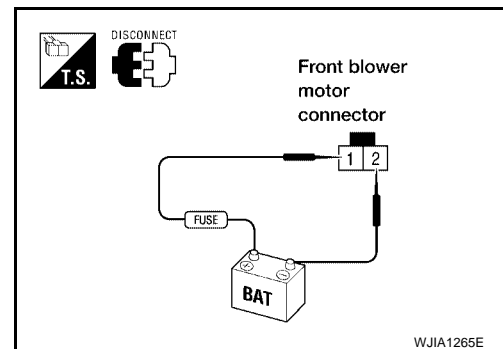

A  
B  
C  
D  
E  
F  
G  
H  
I  
ATC  
K  
L  
M

# TROUBLE DIAGNOSIS

EJS004P9

## Rear Blower Motor Circuit

SYMPTOM:

- Blower motor operation is malfunctioning.

### INSPECTION FLOW

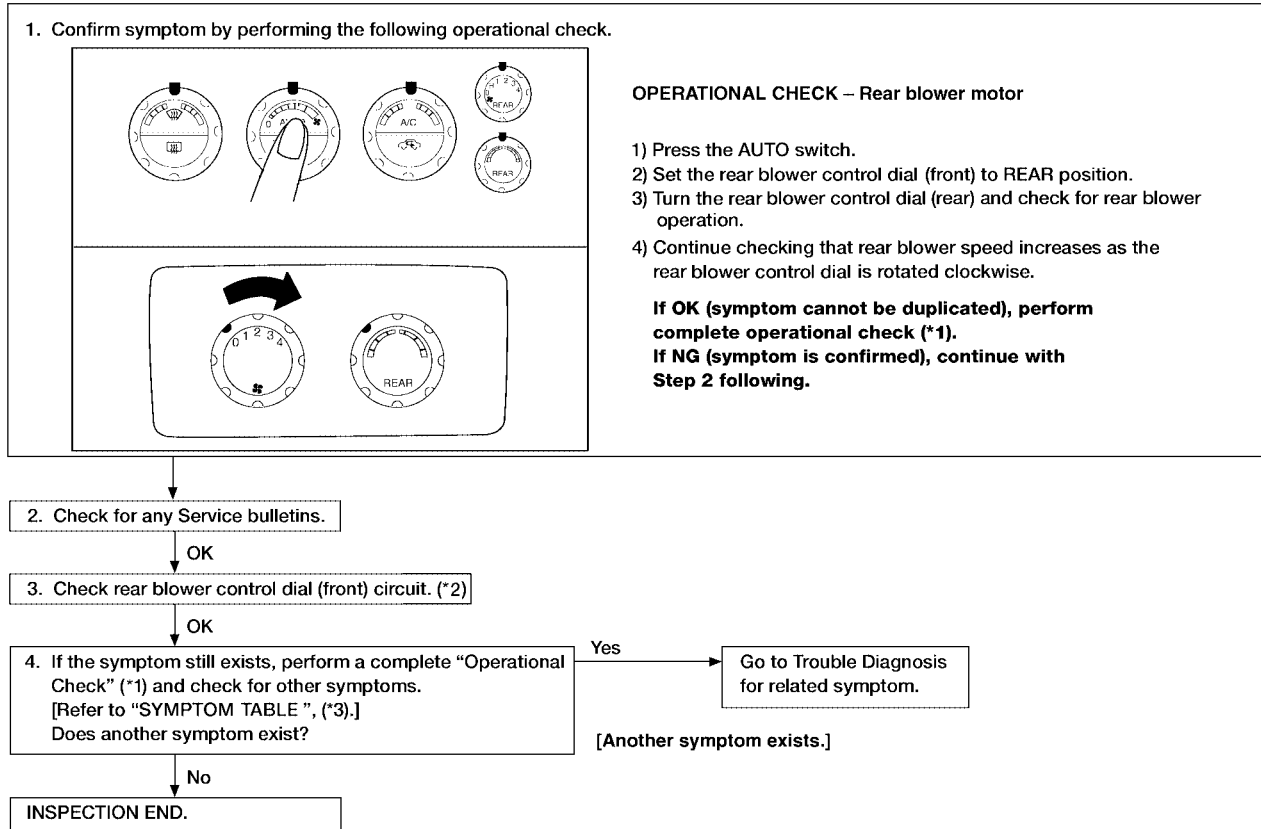

WJIA1266E

\*1 [ATC-55, "Operational Check \(Rear\)"](#) \*2 [ATC-91, "Rear Blower Switch \(Front\)"](#)

\*3 [ATC-36, "SYMPTOM TABLE"](#)



# TROUBLE DIAGNOSIS

## 3. CHECK REAR BLOWER SWITCH (REAR)

Refer to [ATC-91, "Rear Air Control"](#) .

OK or NG

OK >> GO TO 4.

NG >> Replace rear blower switch (rear). Refer to [ATC-127, "REAR AIR CONTROL"](#) .

## 4. CHECK CIRCUIT CONTINUITY

1. Turn ignition switch OFF.
2. Disconnect rear blower switch (front) connector and rear air control connector.
3. Check continuity between rear blower switch (front) harness connector M52 terminal 2 and rear air control harness connector M208 terminal 10.

**2 - 10**

**: Continuity should exist.**

OK or NG

OK >> Inspection End.

NG >> Repair harness or connector.

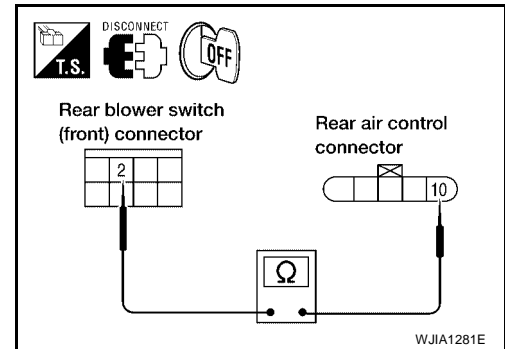

# TROUBLE DIAGNOSIS

## Trouble Diagnosis Procedure For Rear Blower Motor (1 - 4 Speed)

### SYMPTOM:

- Rear blower motor does not rotate when rear blower switch (front) is set at 1 - 4 speed.

### Inspection Flow

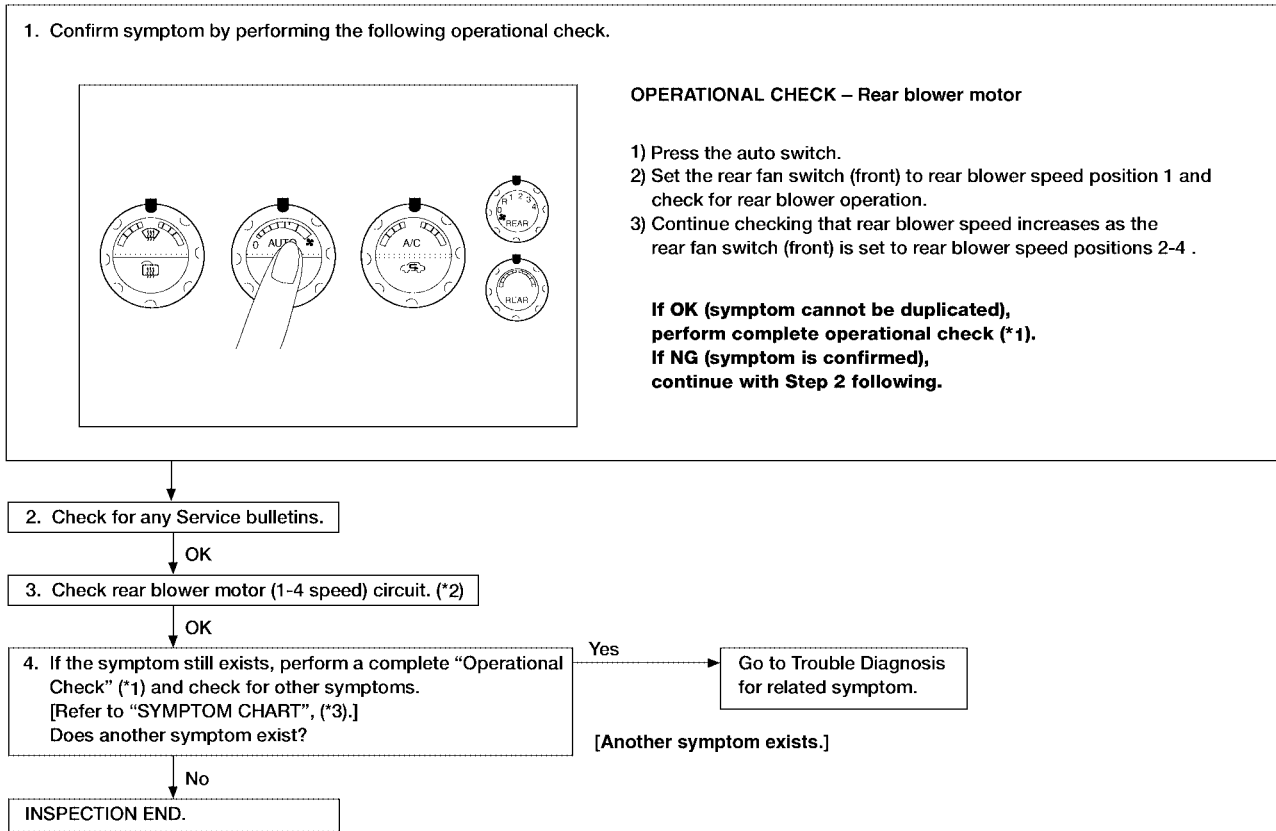

\*1 [.ATC-55. "Operational Check \(Rear\)"](#) .

\*2 [ATC-85. "Trouble Diagnosis Procedure For Rear Blower Motor \(1 - 4 Speed\)"](#)

\*3 [ATC-36. "SYMPTOM TABLE"](#)

WJIA1058E

# TROUBLE DIAGNOSIS

## 1. DIAGNOSTIC PROCEDURE

Blower motor rotates normally at each speed.

OK or NG

- OK >> Inspection End.
- NG >> 1. Does not rotate at any speed, GO TO 2.
- 2. Does not rotate at 1 - 3 speed, GO TO 13.
- 3. Does not rotate at 4 speed, GO TO 18.

## 2. CHECK FUSES

Check 15A fuses (Nos. 28 and 31, located in the fuse and fusible link box). Refer to [PG-84, "FUSE AND FUSIBLE LINK BOX"](#).

OK or NG

- OK >> GO TO 3.
- NG >> GO TO 8.

## 3. CHECK REAR BLOWER MOTOR POWER SUPPLY

1. Turn ignition switch OFF.
2. Disconnect rear blower motor connector.
3. Select any rear blower speed except OFF.
4. Turn ignition switch ON.
5. Check voltage between rear blower motor harness connector B201 terminal 1 and ground.

**1 - Ground : Battery voltage**

OK or NG

- OK >> GO TO 11.
- NG >> GO TO 4.

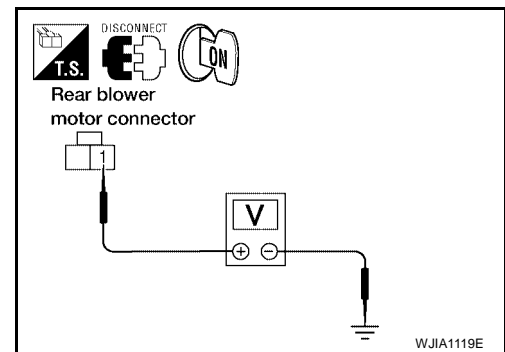

## 4. CHECK REAR BLOWER MOTOR RELAY

Refer to [ATC-91, "Rear Blower Motor Relay"](#).

OK or NG

- OK >> GO TO 5.
- NG >> Replace rear blower motor relay.

## 5. CHECK REAR BLOWER MOTOR POWER FROM RELAY TO REAR BLOWER MOTOR

1. Turn ignition switch OFF.
2. Reconnect rear blower motor connector.
3. Disconnect rear blower motor relay M163.
4. Turn ignition switch ON.
5. Set rear blower switch (front) to any position except OFF, REAR, or 4 - speed.
6. Momentarily (no more than 4 seconds), connect a jumper wire between rear blower motor relay connector M163 (harness side) terminals 6 and 7.

**Rear blower motor should rotate.**

OK or NG

- OK >> GO TO 6.
- NG >> GO TO 10.

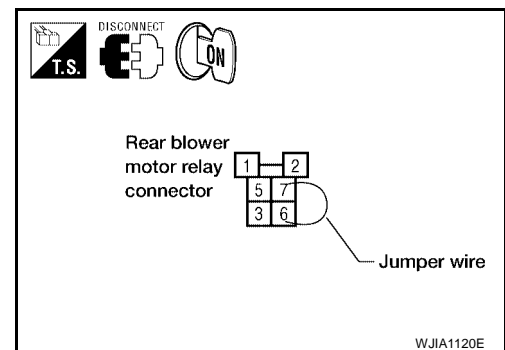

# TROUBLE DIAGNOSIS

## 6. CHECK REAR BLOWER MOTOR RELAY (COIL SIDE) POWER SUPPLY CIRCUIT

Check voltage between rear blower motor relay harness connector M163 terminal 2 and ground.

**2 - Ground** : **Battery voltage**

OK or NG

- OK >> GO TO 7.
- NG >> Repair harness or connector.

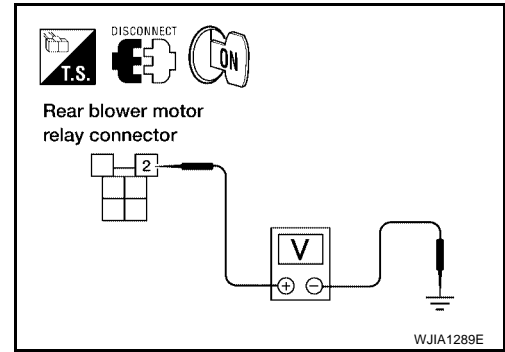

## 7. CHECK REAR BLOWER MOTOR RELAY (COIL SIDE) GROUND CIRCUIT

1. Turn ignition switch OFF.
2. Disconnect the front air control M50.
3. Check continuity between rear blower motor relay harness connector M163 terminal 1 and front air control harness connector M50 terminal 39.

**1 - 39** : **Continuity should exist.**

OK or NG

- OK >> Replace front air control. Refer to [ATC-127, "FRONT AIR CONTROL"](#).
- NG >> Repair harness or connector.

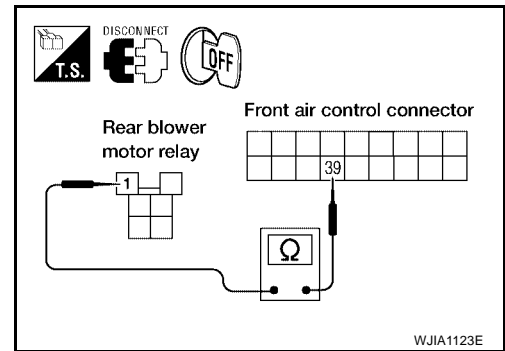

## 8. REPLACE FUSE

Refer to [PG-84, "FUSE AND FUSIBLE LINK BOX"](#).  
Fuse should not open when rear blower motor is activated.

OK or NG

- OK >> Inspection End.
- NG >> GO TO 9.

## 9. CHECK REAR BLOWER MOTOR

Refer to [ATC-92, "Rear Blower Motor"](#).

OK or NG

- OK >> Repair harness between the rear blower motor and the fuse.
- NG >> Replace rear blower motor. refer to [ATC-133, "REAR BLOWER MOTOR"](#)

## 10. CHECK REAR BLOWER MOTOR RELAY (SWITCH SIDE) POWER SUPPLY CIRCUIT

1. Turn ignition switch OFF.
2. Disconnect rear blower motor relay M163.
3. Check voltage between rear blower motor relay harness connector E25 terminals 6 and 3, and ground.

**3, 6 - Ground** : **Battery voltage should exist.**

OK or NG

- OK >> GO TO 20.
- NG >> Repair harness or connector.

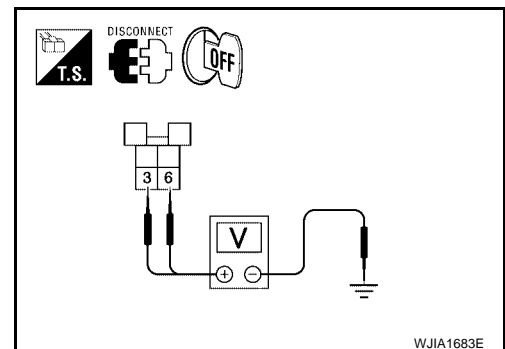

# TROUBLE DIAGNOSIS

## 11. CHECK REAR BLOWER MOTOR

Refer to [ATC-92, "Rear Blower Motor"](#) .

OK or NG

OK >> GO TO 12.

NG >> Replace rear blower motor. Refer to [ATC-133, "REAR BLOWER MOTOR"](#) .

## 12. CHECK REAR BLOWER SWITCH (FRONT)

Refer to [ATC-91, "Rear Blower Switch \(Front\)"](#) .

OK or NG

OK >> GO TO 15.

NG >> Replace rear blower switch (front). Refer to [ATC-127, "FRONT AIR CONTROL"](#) .

## 13. CHECK REAR BLOWER MOTOR RESISTOR

Refer to [ATC-92, "Rear Blower Motor Resistor"](#) .

OK or NG

OK >> GO TO 14.

NG >> Replace rear blower motor resistor. Refer to [ATC-148, "REAR BLOWER MOTOR RESISTOR"](#) .

## 14. CHECK REAR BLOWER SWITCH (FRONT) CIRCUIT

1. Turn ignition switch OFF.
2. Disconnect rear blower switch (front) M52.
3. Reconnect rear blower motor resistor harness connector B133.
4. Turn ignition switch ON.
5. Check voltage between each rear blower switch (front) connector M52 terminals 3, 5, 7, and 8, and ground.

Terminal No.		Voltage (Approx.)
(+)	(-)	
3	Ground	Battery voltage
5		
7		
8		

OK or NG

OK >> GO TO 17.

NG >> GO TO 16.

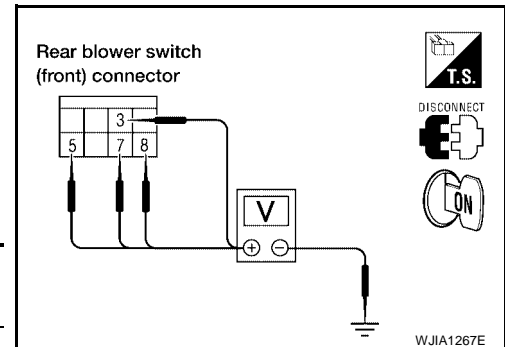



# TROUBLE DIAGNOSIS

## 15. CHECK REAR BLOWER MOTOR GROUND CIRCUIT TO REAR BLOWER MOTOR RESISTOR

1. Turn ignition switch OFF.
2. Disconnect rear blower motor and rear blower motor resistor connectors.
3. Check continuity between rear blower motor connector B201 terminal 2 and rear blower motor resistor harness connector B133 terminal 3.

**2 - 3 : Continuity should exist.**

4. Check continuity between rear blower motor connector B201 terminal 2 and ground.

**2 - Ground : Continuity should not exist.**

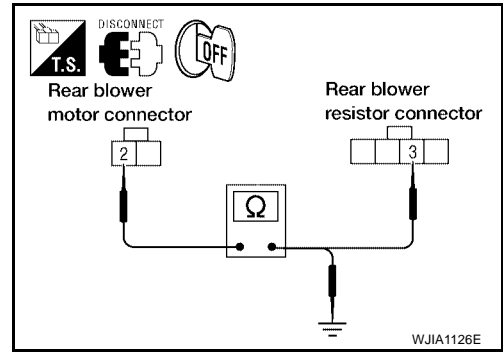

**OK or NG**

OK >> GO TO 16.

NG >> Repair harness or connector.

## 16. CHECK REAR BLOWER SWITCH (FRONT) CIRCUIT

1. Turn ignition switch OFF.
2. Disconnect rear blower switch (front) connector.
3. Check continuity between rear blower switch (front) connector M52 (A) terminals 3, 7, and 8, and rear blower motor resistor connector B133 (B) terminals 1, 4, and 2.

A		B		Continuity
Connector	Terminal	Connector	Terminal	
Rear blower switch (front): M52	3	Rear blower motor resistor: B133	1	Yes
Rear blower switch (front): M52	7	Rear blower motor resistor: B133	4	Yes
Rear blower switch (front): M52	8	Rear blower motor resistor: B133	2	Yes

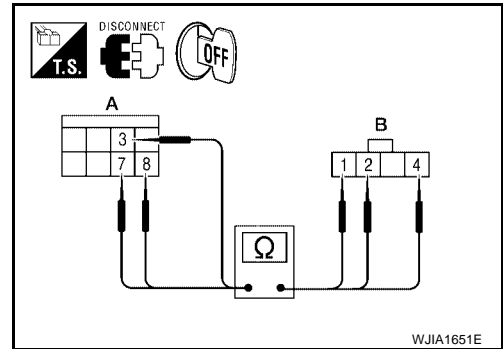

**OK or NG**

OK >> Repair harness between rear blower motor resistor and the rear blower motor.

NG >> Repair harness or connector.

# TROUBLE DIAGNOSIS

## 17. CHECK REAR FAN SWITCH (FRONT) CIRCUIT

1. Turn ignition switch OFF.
2. Disconnect rear air control connector.
3. Check continuity between rear blower switch (front) connector M52 (A) terminals 3, 5, 7), and 8, and rear air control connector R208 (B) terminals 9, 6, 8, and 7.

A		B		Continuity
Connector	Terminal	Connector	Terminal	
Rear blower switch (front): M52	3	Rear air control: M208	9	Yes
Rear blower switch (front): M52	5	Rear air control: M208	6	Yes
Rear blower switch (front): M52	7	Rear air control: M208	8	Yes
Rear blower switch (front): M52	8	Rear air control: M208	7	Yes

OK or NG

OK >> GO TO 18.

NG >> Repair harness or connector.

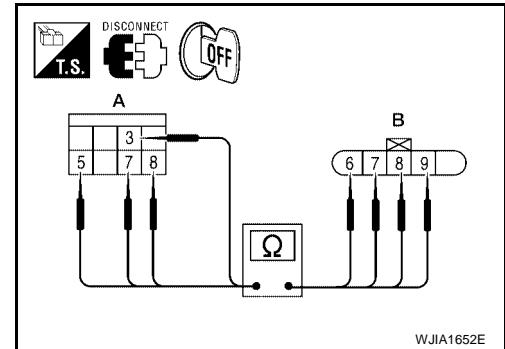

## 18. CHECK REAR BLOWER SWITCH (FRONT)

Refer to [ATC-91, "Rear Blower Switch \(Front\)"](#) .

OK or NG

OK >> GO TO 19.

NG >> Replace rear blower switch (front). Refer to [ATC-127, "FRONT AIR CONTROL"](#) .

## 19. CHECK REAR BLOWER SWITCH (REAR) IN REAR AIR CONTROL

Refer to [ATC-91, "Rear Air Control"](#) .

OK or NG

OK >> Repair harness between rear blower motor and rear blower switch (front) or rear air control.

NG >> Replace rear air control. Refer to [ATC-127, "REAR AIR CONTROL"](#) .

## 20. CHECK CIRCUIT BETWEEN FRONT AIR CONTROL AND FUSE BLOCK (J/B) [REAR BLOWER MOTOR RELAY (COIL SIDE) POWER]

1. Disconnect rear blower motor relay and fuse block (J/B) connectors M3.
2. Check continuity between rear blower motor relay harness connector M163 terminal 2 and fuse block (J/B) connector M3 terminal 5N.

**Continuity should exist.**

OK or NG

OK >> Replace rear blower motor relay.

NG >> Repair harness or connector.

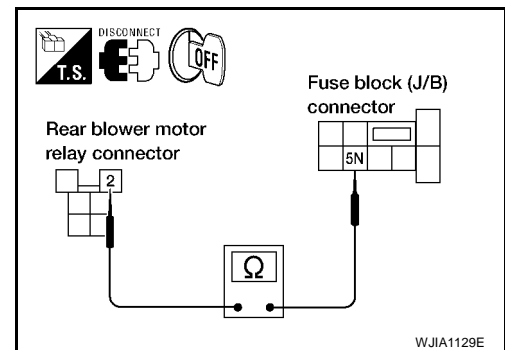

# TROUBLE DIAGNOSIS

## COMPONENT INSPECTION

### Rear Blower Motor Relay

Check circuit continuity between terminals by supplying 12 volts and ground to coil side terminals of relays.

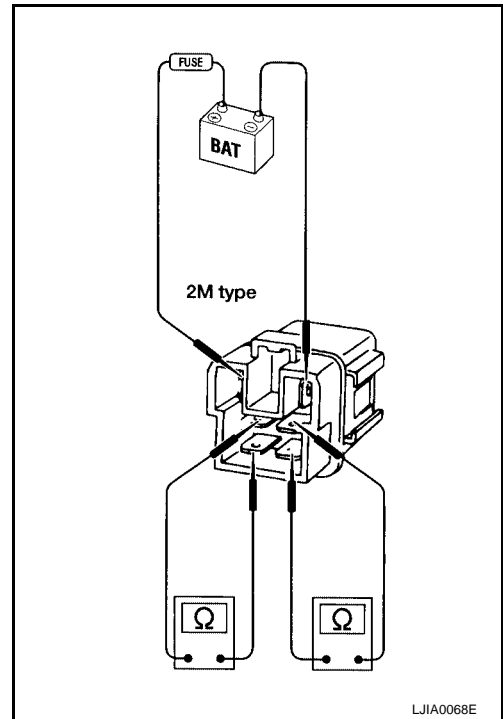

### Rear Air Control

Check continuity between terminals at each switch position.

10 9 8 7 6 Rear air control connector

T.S. DISCONNECT	SWITCH POSITION		TERMINAL			
	OFF	1	2	3	4	
					○	
				○		
		○				
	○	○	○	○		

WJIA1130E

### Rear Blower Switch (Front)

Check continuity between terminals at each switch position.

4 3 2 1  
8 7 6 5 Rear blower switch (front) connector

T.S. DISCONNECT	SWITCH POSITION		TERMINAL			
	OFF	REAR	1	2	3	4
						○
					○	
				○		
		○				
	○	○	○	○	○	

WJIA1284E

A  
B  
C  
D  
E  
F  
G  
H

I

ATC

K

L

M

# TROUBLE DIAGNOSIS

## Rear Blower Motor

Check that there are no foreign particles inside the intake unit.  
Apply 12 volts to terminal 1 and ground to terminal 2 and ensure that the blower motor rotates freely and quietly.

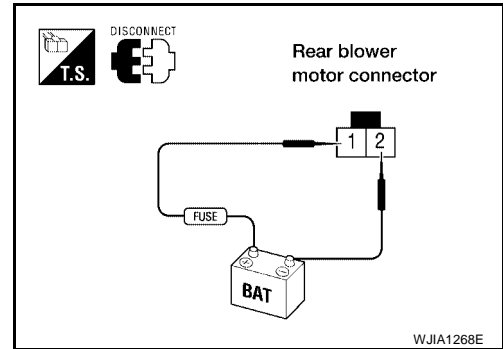

## Rear Blower Motor Resistor

Check continuity between terminals. There will be resistance, but there should not be an open or short between any two terminals.

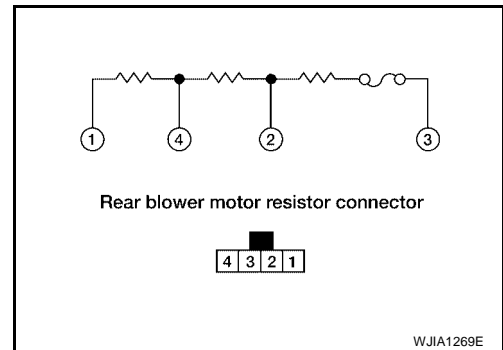

# TROUBLE DIAGNOSIS

EJS004PA

## Rear Air Control Circuit

SYMPTOM:

- Temperature cannot be adjusted from the rear air control.

### INSPECTION FLOW

1. Confirm symptom by performing the following operational check.

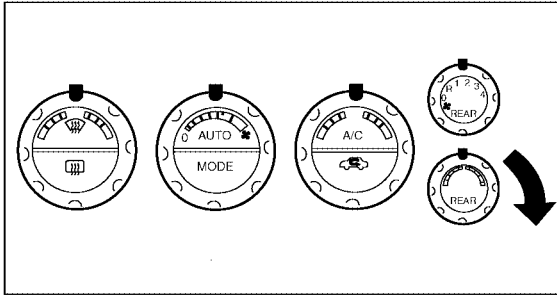

#### OPERATIONAL CHECK

Temperature increase

- Press AUTO button (Rear blower only operates when front blower is on).
- Turn the temperature control dial clockwise.
- Check for hot air at rear foot discharge air outlets.

Temperature decrease

- Turn the temperature control dial counterclockwise.
- Check for cold air at rear vent discharge air outlets.

If OK (symptom cannot be duplicated), perform complete operational check (\*1).

If NG (symptom is confirmed), continue with STEP-2 following.

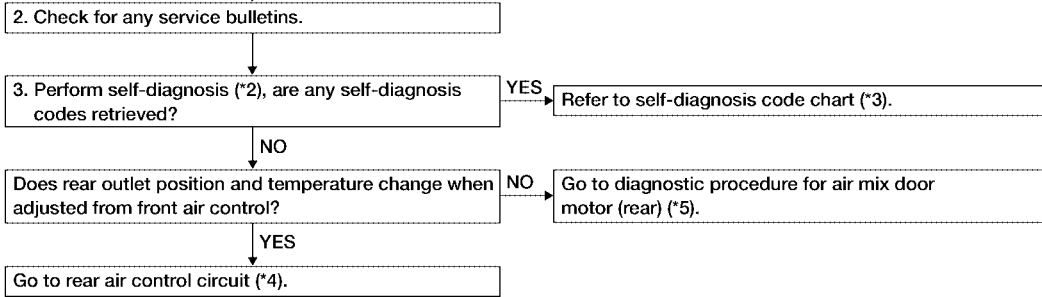
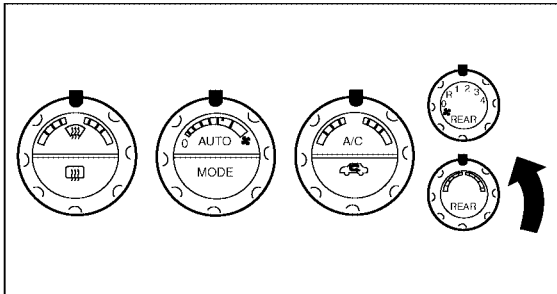

\*1 [ATC-55. "Operational Check \(Rear\)"](#)

\*2 [ATC-51. "A/C System Self-diagnosis Function"](#)

\*3 [ATC-52. "SELF-DIAGNOSIS CODE CHART"](#)

\*4 [ATC-94. "DIAGNOSTIC PROCEDURE FOR REAR AIR CONTROL"](#)

\*5 [ATC-69. "DIAGNOSTIC PROCEDURE FOR AIR MIX DOOR MOTOR \(REAR\)"](#)

WJIA1270E

# TROUBLE DIAGNOSIS

## SYSTEM DESCRIPTION

### Component Parts

Rear air control system components are:

- Front air control
- Rear air control
- Air mix door motor (rear)
- Rear blower motor relay
- Rear blower motor resistor
- Rear blower motor

### System Operation

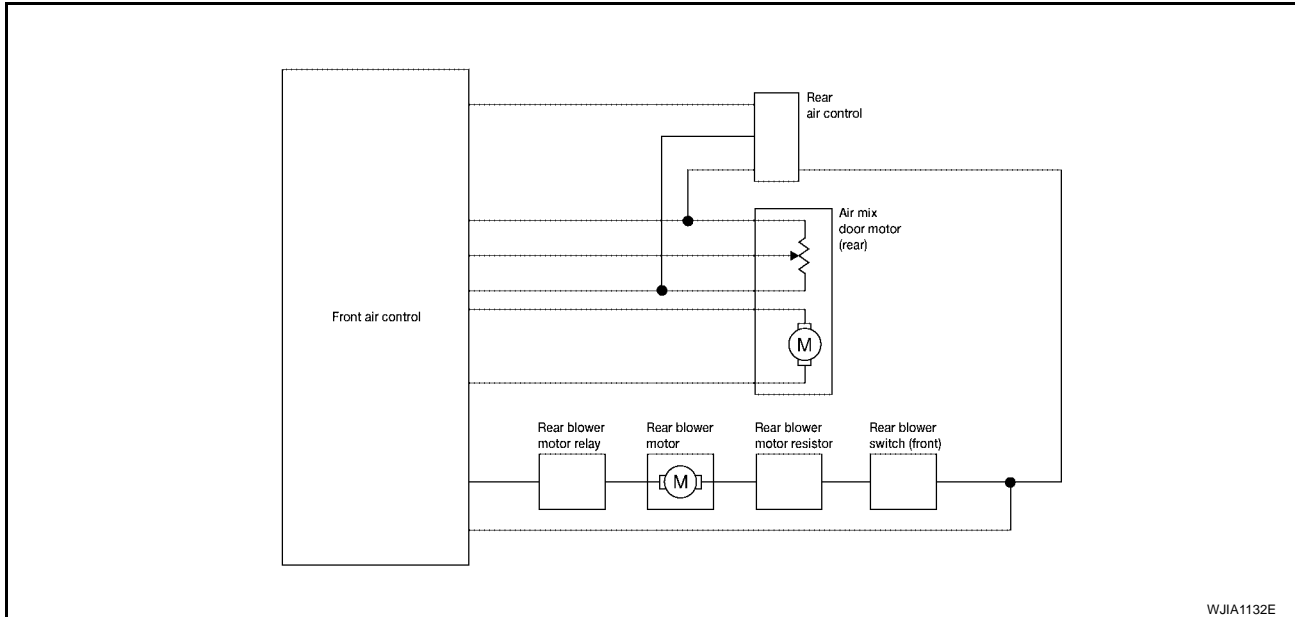

### Rear Air Control

When the rear fan switch (front) (integral to the front air control) is in the REAR position the rear blower motor speeds and the rear temperature/mode are controlled by the rear fan switch (rear) and the rear temperature switch (rear) (both integral to the rear air control).

### DIAGNOSTIC PROCEDURE FOR REAR AIR CONTROL

SYMPTOM:

- Blower motor operation is malfunctioning. Refer to [ATC-82, "Rear Blower Motor Circuit"](#) .
- Temperature/mode operation is malfunctioning.

#### 1. CHECK OPERATION FROM FRONT AIR CONTROL

Does rear temperature/mode operate normally from front air control?

YES or NO

YES >> GO TO 2.

NO >> Refer to [ATC-69, "DIAGNOSTIC PROCEDURE FOR AIR MIX DOOR MOTOR \(REAR\)"](#) .



# TROUBLE DIAGNOSIS

EJS004PB

## Magnet Clutch Circuit

SYMPTOM: Magnet clutch does not engage.

### INSPECTION FLOW

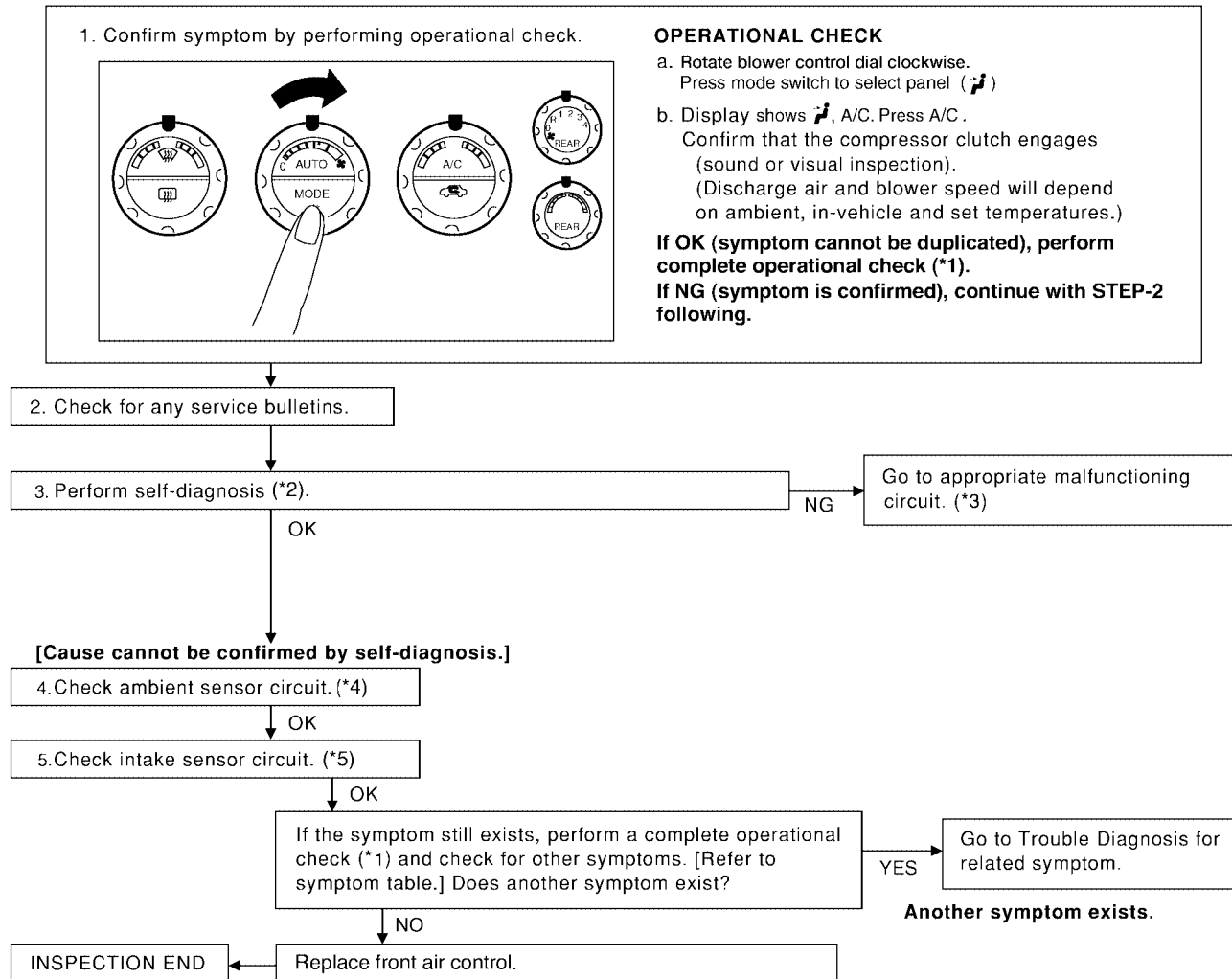

\*1 [.ATC-53. "Operational Check \(Front\)"](#)

\*2 [ATC-51. "A/C System Self-diagnosis Function"](#)

\*3 [ATC-52. "SELF-DIAGNOSIS CODE CHART"](#)

\*4 [ATC-117. "Ambient Sensor 1 Circuit"](#)

\*5 [ATC-125. "Intake Sensor Circuit"](#)

WJIA1285E



# TROUBLE DIAGNOSIS

## SYSTEM DESCRIPTION

The front air control controls compressor operation based on ambient and intake temperature and a signal from ECM.

### Low Temperature Protection Control

The front air control will turn the compressor ON or OFF as determined by a signal detected by the intake sensor and the ambient sensor.

When intake air temperature is higher than the preset value, the compressor turns ON. The compressor turns OFF when intake air temperature is lower than the preset value. That preset value is dependent on the ambient temperature, refer to the following table.

Ambient temperature °C (°F)	Compressor ON intake temperature °C (°F)	Compressor OFF intake temperature °C (°F)
0 (32)	2.5 (37)	2.0 (36)
10 (50)	2.5 (37)	2.0 (36)
20 (68)	2.5 (37)	1.5 (35)
30 (86)	2.0 (36)	0.5 (33)
40 (104)	2.0 (36)	0.5 (33)
50 (122)	2.0 (36)	0.5 (33)

## DIAGNOSTIC PROCEDURE FOR MAGNET CLUTCH

SYMPTOM: Magnet clutch does not engage when A/C switch is ON.

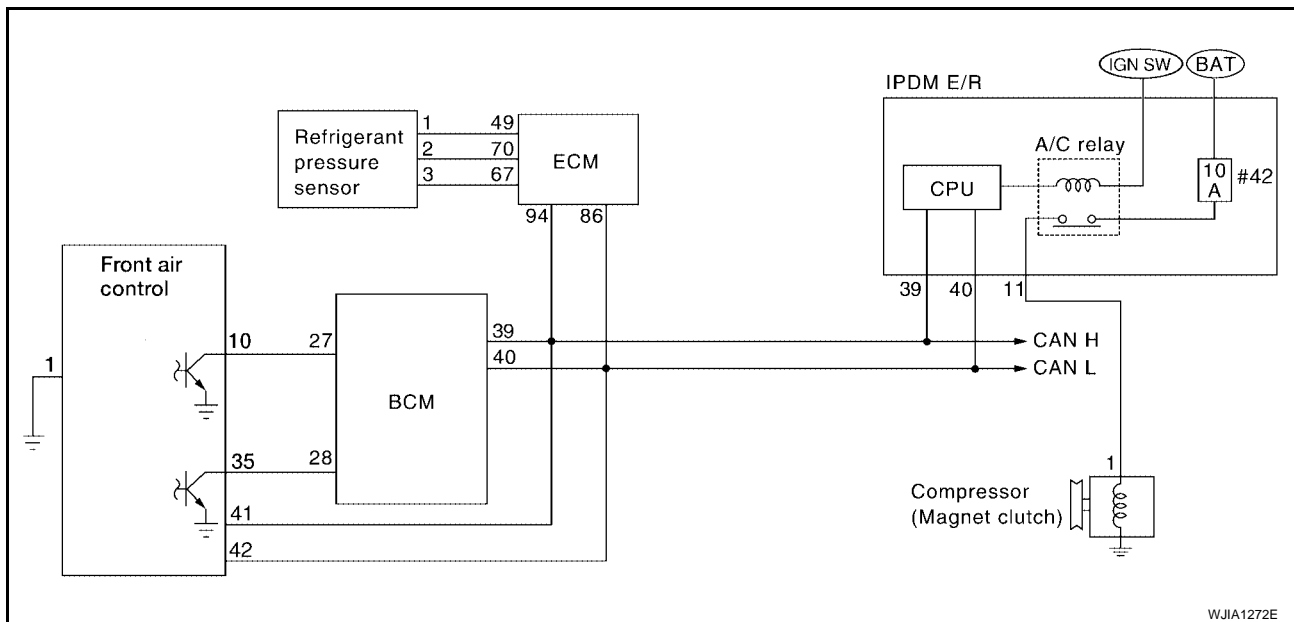

### 1. CHECK INTAKE AND AMBIENT SENSOR CIRCUITS

Check intake and ambient sensors. Refer to [ATC-51, "A/C System Self-diagnosis Function"](#) .

OK or NG

OK >> GO TO 2.

NG >> Malfunctioning intake sensor. Refer to [ATC-125, "Intake Sensor Circuit"](#) .

# TROUBLE DIAGNOSIS

## 2. PERFORM AUTO ACTIVE TEST

Refer to [PG-24, "Auto Active Test"](#) .  
Does magnet clutch operate?

YES or NO

YES >> ●  WITH CONSULT-II  
GO TO 5.

●  WITHOUT CONSULT-II  
GO TO 6.

NO >> Check 10A fuse (No. 42, located in IPDM E/R), and GO TO 3.

## 3. CHECK CIRCUIT CONTINUITY BETWEEN IPDM E/R AND COMPRESSOR

1. Turn ignition switch OFF.
2. Disconnect IPDM E/R connector and compressor (magnet clutch) connector.
3. Check continuity between IPDM E/R harness connector E119 terminal 11 and compressor harness connector F3 terminal 1.

**11 – 1 : Continuity should exist.**

OK or NG

OK >> GO TO 4.

NG >> Repair harness or connector.

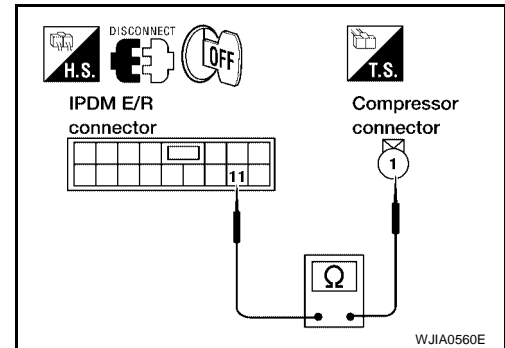

## 4. CHECK MAGNET CLUTCH CIRCUIT

Check for operation sound when applying battery voltage direct current to terminal.

OK or NG

OK >> Replace IPDM E/R. Refer to [PG-32, "Removal and Installation of IPDM E/R"](#) .

NG >> Replace magnet clutch. Refer to [ATC-159, "Removal and Installation for Compressor Clutch"](#) .

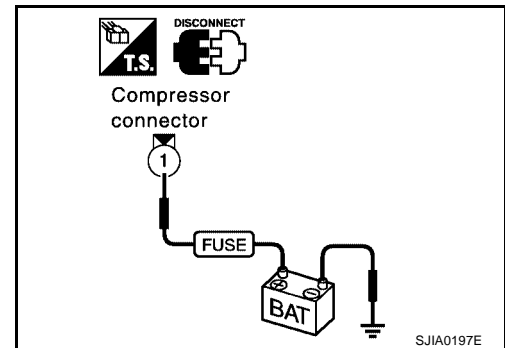

## 5. CHECK BCM INPUT (COMPRESSOR ON) SIGNAL

Check compressor ON/OFF signal. Refer to [ATC-34, "CONSULT-II Function \(BCM\)"](#) .

**A/C SW ON : COMP ON SIG ON**

**A/C SW OFF : COMP ON SIG OFF**

OK or NG

OK >> GO TO 8.

NG >> GO TO 6.

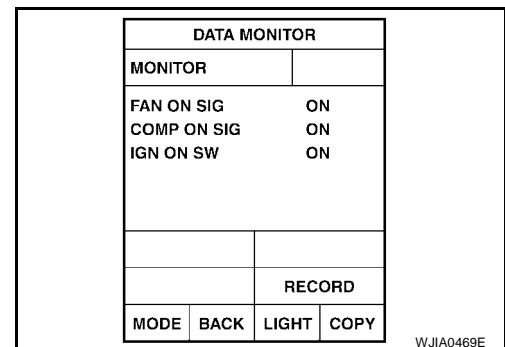

# TROUBLE DIAGNOSIS

## 6. CHECK CIRCUIT CONTINUITY BETWEEN BCM AND FRONT AIR CONTROL

1. Turn ignition switch OFF.
2. Disconnect BCM connector and front air control connector.
3. Check continuity between BCM harness connector M18 terminal 27 and front air control harness connector M49 terminal 10.

**27 - 10**

**Continuity should exist.**

**OK or NG**

OK >> GO TO 7.

NG >> Repair harness or connector.

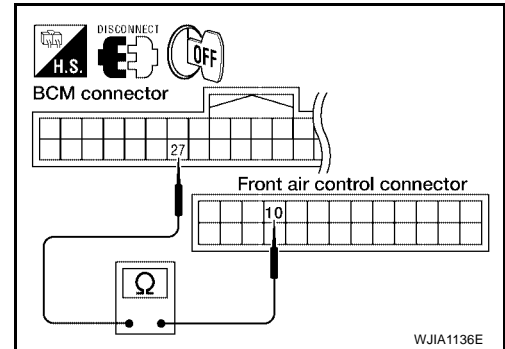

## 7. CHECK VOLTAGE FOR FRONT AIR CONTROL (COMPRESSOR ON SIGNAL)

1. Reconnect BCM connector and front air control connector.
2. Turn ignition switch ON.
3. Check voltage between front air control harness connector M49 terminal 10 and ground.

Terminals		(-)	Condition	Voltage (Approx.)
(+)	Terminal No.			
Front air control connector				
M49	10	Ground	A/C switch: ON	0V
			A/C switch: OFF	5V

**OK or NG**

OK >> GO TO 8.

NG-1 >> If the voltage is approx. 5V when A/C switch is ON, replace front air control. Refer to [ATC-127](#), "[FRONT AIR CONTROL](#)".

NG-2 >> If the voltage is approx. 0V when A/C switch is OFF, replace BCM. Refer to [BCS-27](#), "[Removal and Installation](#)".

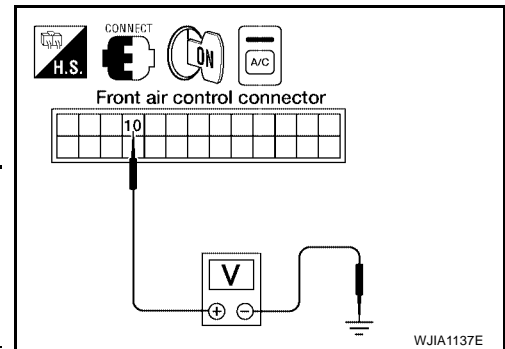

A  
B  
C  
D  
E  
F  
G  
H  
I  
K  
L  
M

ATC

# TROUBLE DIAGNOSIS

## 8. CHECK REFRIGERANT PRESSURE SENSOR

 WITH CONSULT-II

1. Start engine.
2. Check voltage of refrigerant pressure sensor. Refer to [ATC-34, "CONSULT-II Function \(BCM\)"](#) .



 WITHOUT CONSULT-II

1. Start engine.
2. Check voltage between ECM harness connector F54 terminal 70 and ground.

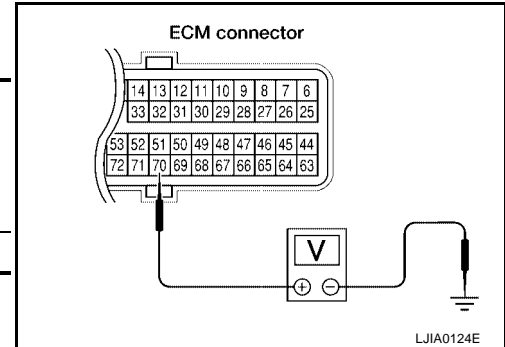
Terminals		Condition	Voltage (Approx.)
(+)	(-)		
ECM connector	Terminal No.		
F54	70	Ground	A/C switch: ON



OK or NG

- OK >> ●  WITH CONSULT-II  
GO TO 9.
-  WITHOUT CONSULT-II  
GO TO 10.
- NG >> Refer to [EC-659, "REFRIGERANT PRESSURE SENSOR"](#) .

## 9. CHECK BCM INPUT (FAN ON) SIGNAL

Check FAN ON/OFF signal. Refer to [ATC-34, "CONSULT-II Function \(BCM\)"](#) .

**FRONT BLOWER CONTROL : FAN ON SIG ON  
DIAL ON**

**FRONT BLOWER CONTROL : FAN ON SIG OFF  
DIAL OFF**

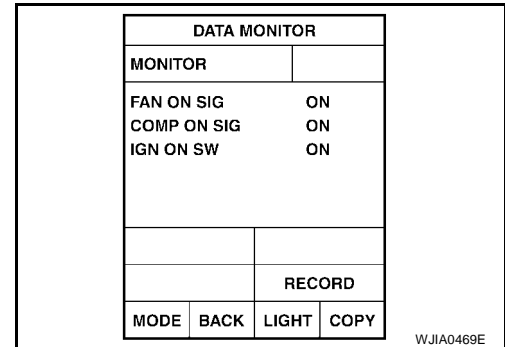

OK or NG

- OK >> GO TO 12.
- NG >> GO TO 10.

## 10. CHECK CIRCUIT CONTINUITY BETWEEN BCM AND FRONT AIR CONTROL

1. Turn ignition switch OFF.
2. Disconnect BCM connector and front air control connector.
3. Check continuity between BCM harness connector M18 terminal 28 and front air control harness connector M50 terminal 35.

**28 - 35** **Continuity should exist.**

OK or NG

- OK >> GO TO 11.
- NG >> Repair harness or connector.

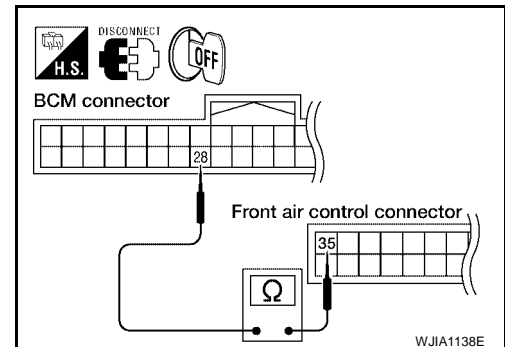

# TROUBLE DIAGNOSIS

## 11. CHECK VOLTAGE FOR FRONT AIR CONTROL (FAN ON SIGNAL)

1. Reconnect BCM connector and front air control connector.
2. Turn ignition switch ON.
3. Check voltage between front air control harness connector M50 terminal 35 and ground.

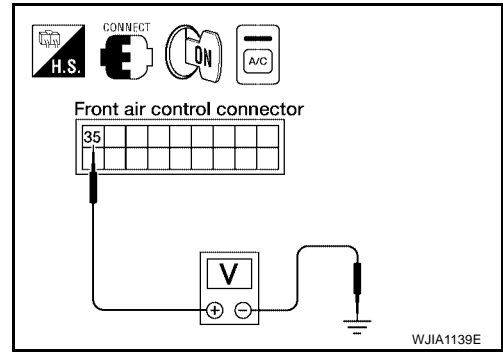

Terminals		(-)	Condition	Voltage (Approx.)
(+)	Terminal No.			
Front air control connector				
M50	35	Ground	A/C switch: ON Blower motor operates	0V
			A/C switch: OFF	5V

### OK or NG

OK >> GO TO 12.

NG-1 >> If the voltage is approx. 5V when blower motor is ON, replace front air control. Refer to [ATC-127, "FRONT AIR CONTROL"](#).

NG-2 >> If the voltage is approx. 0V when blower motor is OFF, replace BCM. Refer to [BCS-27, "Removal and Installation"](#).

## 12. CHECK CAN COMMUNICATION

Check CAN communication. Refer to [LAN-25, "CAN COMMUNICATION"](#).

- BCM – ECM
- ECM – IPDM E/R
- ECM – Front air control

### OK or NG

OK >> Inspection End.

NG >> Repair or replace malfunctioning part(s).

A  
B  
C  
D  
E  
F  
G  
H  
I  
K  
L  
M

ATC

# TROUBLE DIAGNOSIS

EJS004PC

## Insufficient Cooling

SYMPTOM: Insufficient cooling

### INSPECTION FLOW

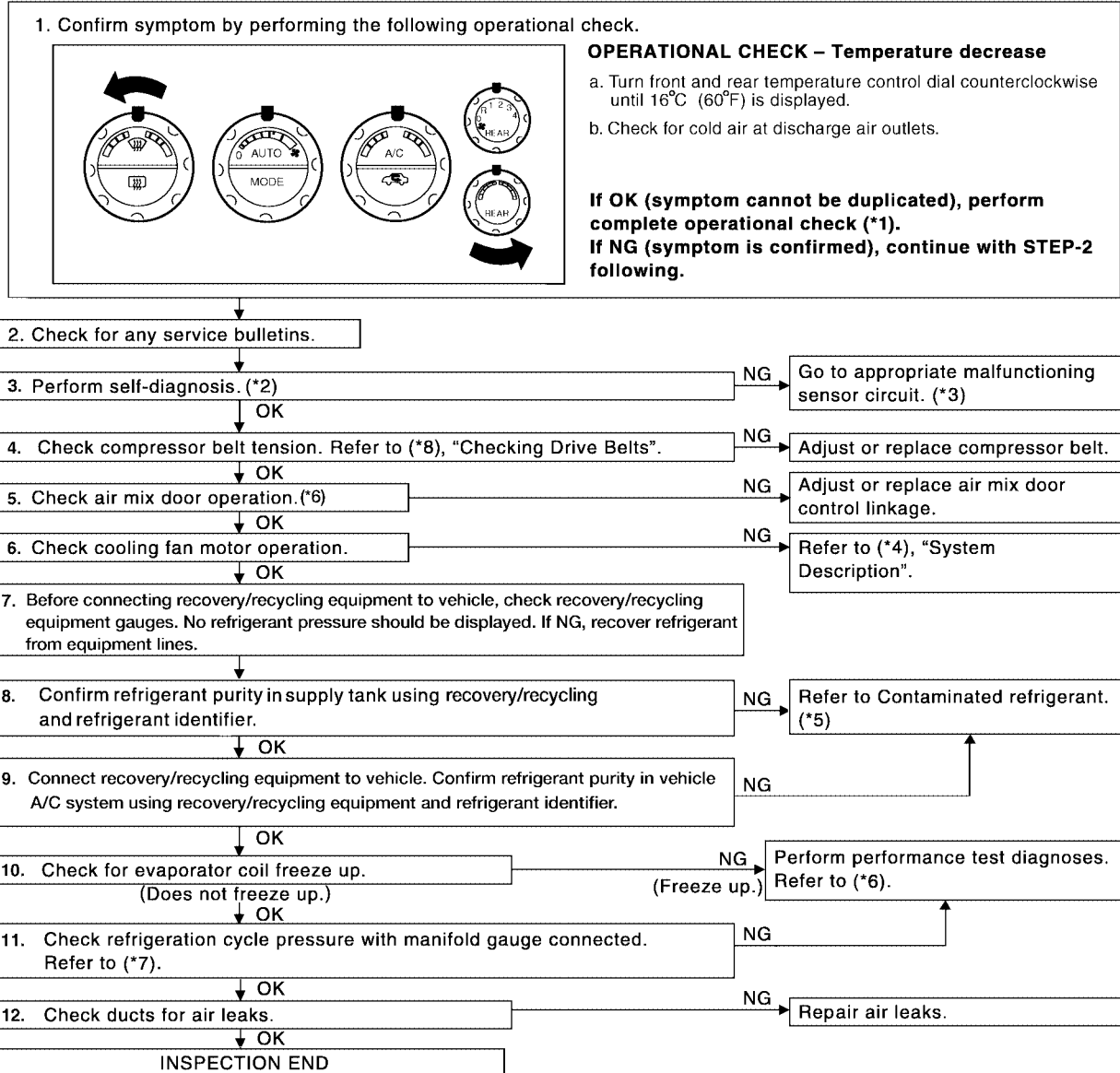

WJIA1464E

\*1 [.ATC-53, "Operational Check \(Front\)"](#) .

\*2 [ATC-51, "A/C System Self-diagnosis Function"](#)

\*3 [ATC-52, "SELF-DIAGNOSIS CODE CHART"](#)

\*4 [EC-493, "SYSTEM DESCRIPTION"](#)

\*5 [ATC-5, "Contaminated Refrigerant"](#)

\*6 [.ATC-103, "PERFORMANCE TEST DIAGNOSES"](#)

\*7 [ATC-105, "Test Reading"](#)

\*8 [MA-13, "Checking Drive Belts"](#)

# TROUBLE DIAGNOSIS

## PERFORMANCE TEST DIAGNOSES

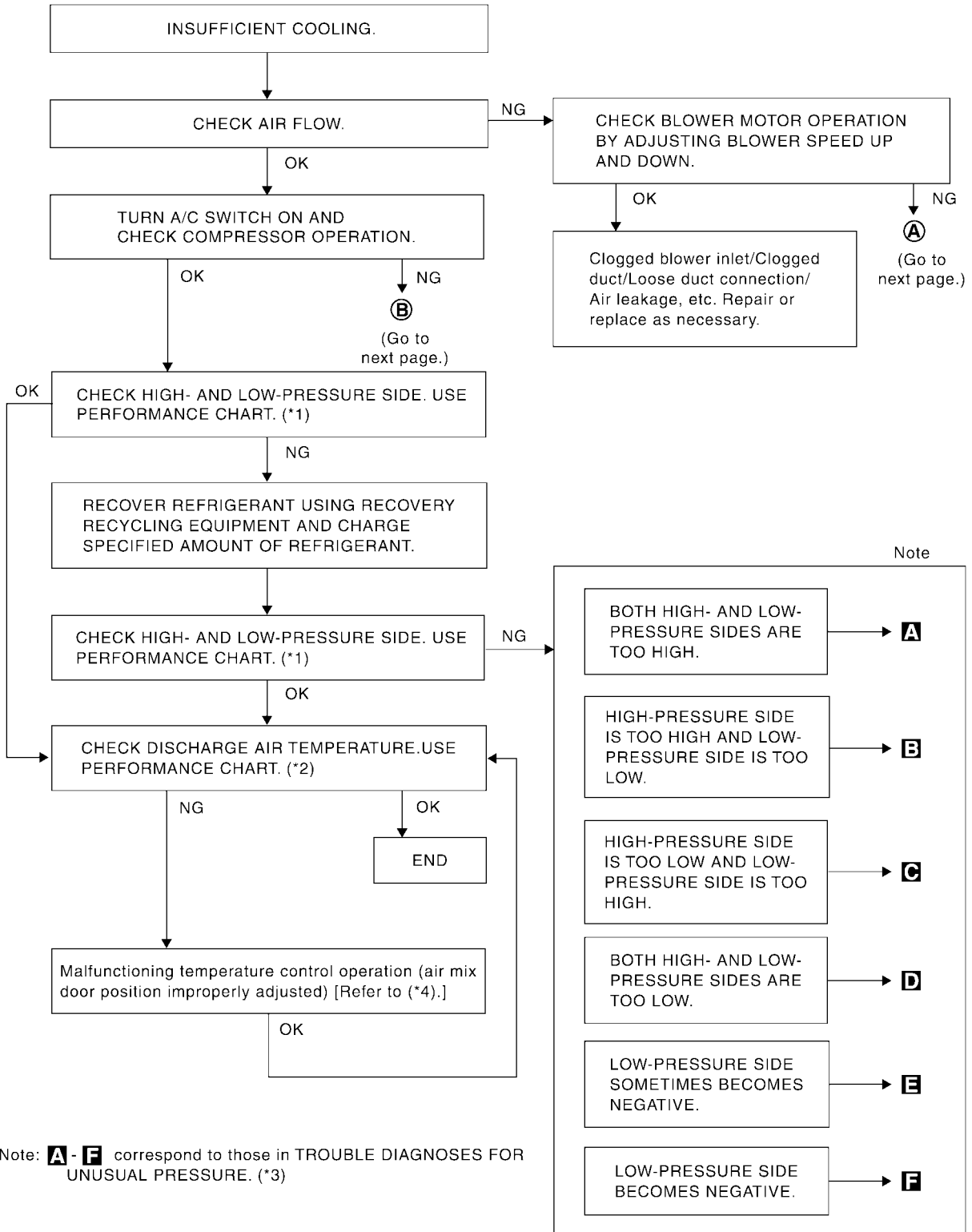

Note: **A - F** correspond to those in TROUBLE DIAGNOSES FOR UNUSUAL PRESSURE. (\*3)

\*1 [ATC-105, "PERFORMANCE CHART"](#)

\*2 [ATC-105, "PERFORMANCE CHART"](#)

\*3 [ATC-106, "Trouble Diagnoses for Unusual Pressure"](#)

\*4 [ATC-63, "Air Mix Door Motor Circuit"](#)

RJIA1601E

# TROUBLE DIAGNOSIS

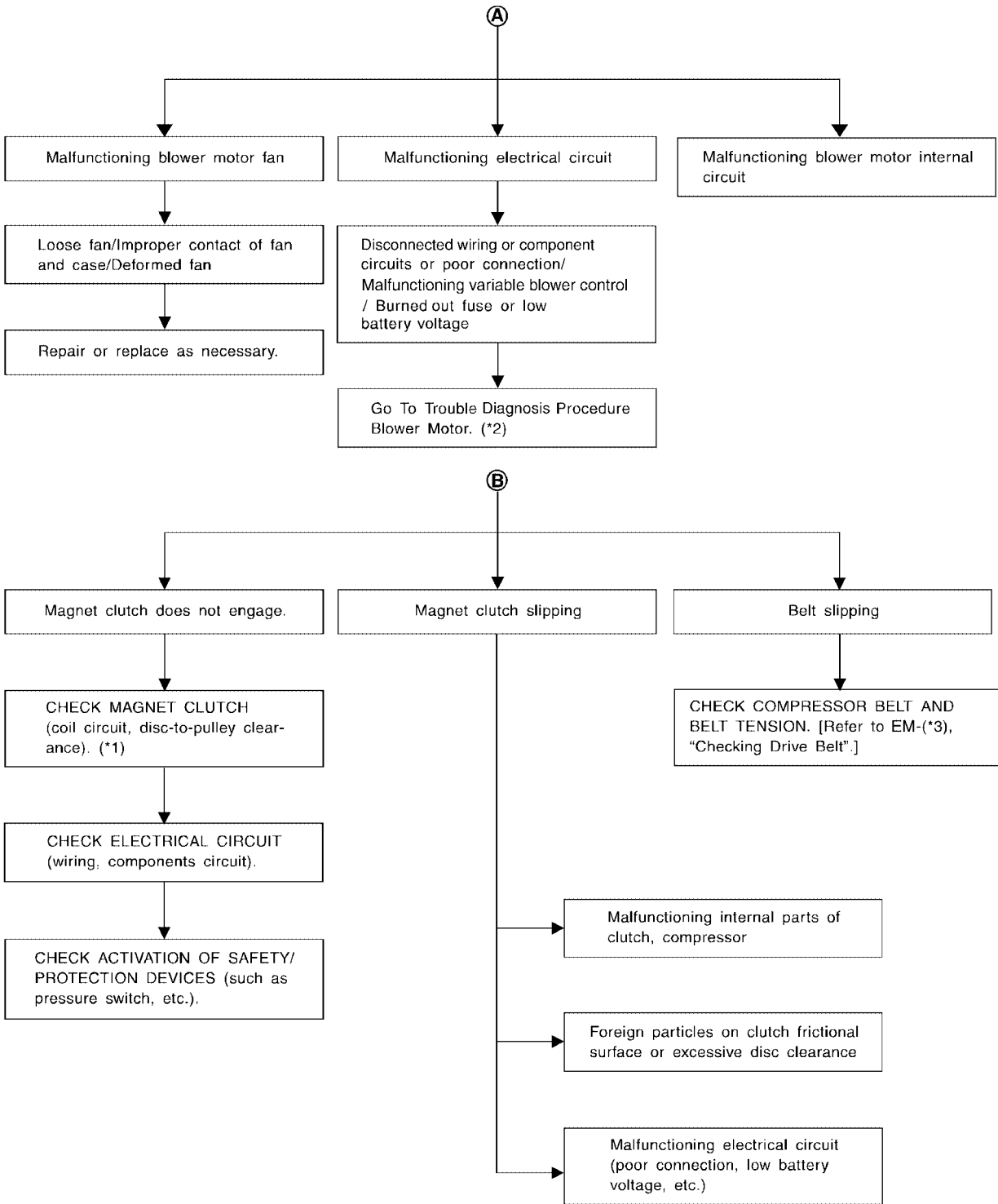

WJIA1371E

\*1 [ATC-159. "Removal and Installation for Compressor Clutch"](#)

\*2 [ATC-75. "Front Blower Motor Circuit"](#)

\*3 [MA-13. "Checking Drive Belts"](#)





# TROUBLE DIAGNOSIS

## PERFORMANCE CHART

### Test Condition

Testing must be performed as follows:

Vehicle location	Indoors or in the shade (in a well-ventilated place)
Doors	Closed
Door window	Open
Hood	Open
TEMP.	Max. COLD
Mode switch	 (Ventilation) set
Recirculation (REC) switch	 (Recirculation) set
 Blower speed	Max. speed set
Engine speed	Idle speed

Operate the air conditioning system for 10 minutes before taking measurements.

### Test Reading

#### Recirculating-to-discharge Air Temperature Table

Inside air (Recirculating air) at blower assembly inlet		Discharge air temperature at center ventilator °C (°F)
Relative humidity %	Air temperature °C (°F)	
50 - 60	20 (68)	5.3 - 6.5 (42 - 44)
	25 (77)	9.7 - 11.5 (49 - 53)
	30 (86)	13.8 - 16.3 (57 - 61)
	35 (95)	18.0 - 21.2 (64 - 70)
	40 (104)	22.2 - 25.7 (72 - 78)
60 - 70	20 (68)	6.5 - 7.7 (44 - 46)
	25 (77)	11.5 - 13.3 (53 - 56)
	30 (86)	16.3 - 18.8 (61 - 66)
	35 (95)	21.2 - 24.0 (70 - 75)
	40 (104)	25.7 - 29.2 (78 - 85)

#### Ambient Air Temperature-to-operating Pressure Table

Ambient air		High-pressure (Discharge side) kPa (kg/cm <sup>2</sup> , psi)	Low-pressure (Suction side) kPa (kg/cm <sup>2</sup> , psi)
Relative humidity %	Air temperature °C (°F)		
50 - 70	20 (68)	680 - 840 (6.94 - 8.57, 98.6 - 121.8)	160 - 198 (1.63 - 2.02, 23.2 - 28.7)
	25 (77)	800 - 985 (8.16 - 10.05, 116.0 - 142.8)	198 - 245 (2.02 - 2.50, 28.7 - 35.5)
	30 (86)	940 - 1,150 (9.59 - 11.73, 136.3 - 166.8)	225 - 278 (2.30 - 2.84, 32.6 - 40.3)
	35 (95)	1,160 - 1,410 (11.83 - 14.38, 168.2 - 204.5)	273 - 335 (2.78 - 3.42, 39.6 - 48.6)
	40 (104)	1,325 - 1,620 (13.52 - 16.52, 192.1 - 234.9)	325 - 398 (3.32 - 4.06, 47.1 - 57.7)

# TROUBLE DIAGNOSIS

## TROUBLE DIAGNOSES FOR UNUSUAL PRESSURE

Whenever system's high and/or low side pressure is unusual, diagnose using a manifold gauge. The marker above the gauge scale in the following tables indicates the standard (usual) pressure range. Since the standard (usual) pressure, however, differs from vehicle to vehicle, refer to above table (Ambient air temperature-to-operating pressure table).

### Both High- and Low-pressure Sides are Too High

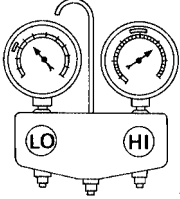
Gauge indication	Refrigerant cycle	Probable cause	Corrective action
<p>Both high- and low-pressure sides are too high.</p>  <p style="text-align: right; font-size: small;">AC359A</p>	<p>Pressure is reduced soon after water is splashed on condenser.</p>	<p>Excessive refrigerant charge in refrigeration cycle</p>	<p>Reduce refrigerant until specified pressure is obtained.</p>
	<p>Air suction by cooling fan is insufficient.</p>	<p>Insufficient condenser cooling performance ↓ 1. Condenser fins are clogged. 2. Improper fan rotation of cooling fan</p>	<ul style="list-style-type: none"> <li>● Clean condenser.</li> <li>● Check and repair cooling fan if necessary.</li> </ul>
	<ul style="list-style-type: none"> <li>● Low-pressure pipe is not cold.</li> <li>● When compressor is stopped high-pressure value quickly drops by approximately 196 kPa (2 kg/cm<sup>2</sup>, 28 psi). It then decreases gradually thereafter.</li> </ul>	<p>Poor heat exchange in condenser (After compressor operation stops, high-pressure decreases too slowly.) ↓ Air in refrigeration cycle</p>	<p>Evacuate and recharge system.</p>
	<p>Engine tends to overheat.</p>	<p>Engine cooling systems malfunction.</p>	<p>Check and repair engine cooling system.</p>
	<ul style="list-style-type: none"> <li>● An area of the low-pressure pipe is colder than areas near the evaporator outlet.</li> <li>● Plates are sometimes covered with frost.</li> </ul>	<ul style="list-style-type: none"> <li>● Excessive liquid refrigerant on low-pressure side</li> <li>● Excessive refrigerant discharge flow</li> <li>● Expansion valve is open a little compared with the specification.</li> </ul> <p>↓ Improper expansion valve adjustment</p>	<p>Replace expansion valve.</p>

### High-pressure Side is Too High and Low-pressure Side is Too Low

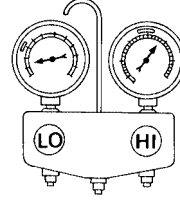
Gauge indication	Refrigerant cycle	Probable cause	Corrective action
<p>High-pressure side is too high and low-pressure side is too low.</p>  <p style="text-align: right; font-size: small;">AC360A</p>	<p>Upper side of condenser and high-pressure side are hot, however, liquid tank is not so hot.</p>	<p>High-pressure tube or parts located between compressor and condenser are clogged or crushed.</p>	<ul style="list-style-type: none"> <li>● Check and repair or replace malfunctioning parts.</li> <li>● Check oil for contamination.</li> </ul>

# TROUBLE DIAGNOSIS

## High-pressure Side is Too Low and Low-pressure Side is Too High

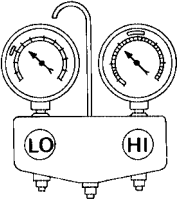
Gauge indication	Refrigerant cycle	Probable cause	Corrective action
High-pressure side is too low and low-pressure side is too high. 	High- and low-pressure sides become equal soon after compressor operation stops.	Compressor pressure operation is improper. ↓ Damaged inside compressor packings.	Replace compressor.
	No temperature difference between high- and low-pressure sides.	Compressor pressure operation is improper. ↓ Damaged inside compressor packings.	Replace compressor.

## Both High- and Low-pressure Sides are Too Low

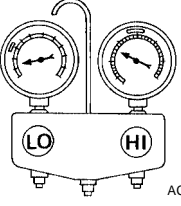
Gauge indication	Refrigerant cycle	Probable cause	Corrective action
Both high- and low-pressure sides are too low. 	<ul style="list-style-type: none"> <li>There is a big temperature difference between liquid tank outlet and inlet. Outlet temperature is extremely low.</li> <li>Liquid tank inlet and expansion valve are frosted.</li> </ul>	Liquid tank inside is slightly clogged.	<ul style="list-style-type: none"> <li>Replace liquid tank.</li> <li>Check oil for contamination.</li> </ul>
	<ul style="list-style-type: none"> <li>Temperature of expansion valve inlet is extremely low as compared with areas near liquid tank.</li> <li>Expansion valve inlet may be frosted.</li> <li>Temperature difference occurs somewhere in high-pressure side.</li> </ul>	High-pressure pipe located between liquid tank and expansion valve is clogged.	<ul style="list-style-type: none"> <li>Check and repair malfunctioning parts.</li> <li>Check oil for contamination.</li> </ul>
	Expansion valve and liquid tank are warm or only cool when touched.	Low refrigerant charge. ↓ Leaking fittings or components.	Check refrigerant system for leaks. Refer to <a href="#">ATC-170, "Checking for Refrigerant Leaks"</a> .
	There is a big temperature difference between expansion valve inlet and outlet while the valve itself is frosted.	Expansion valve closes a little compared with the specification. ↓ 1. Improper expansion valve adjustment. 2. Malfunctioning expansion valve. 3. Outlet and inlet may be clogged.	<ul style="list-style-type: none"> <li>Remove foreign particles by using compressed air.</li> <li>Check oil for contamination.</li> </ul>
	An area of the low-pressure pipe is colder than areas near the evaporator outlet.	Low-pressure pipe is clogged or crushed.	<ul style="list-style-type: none"> <li>Check and repair malfunctioning parts.</li> <li>Check oil for contamination.</li> </ul>
	Air flow volume is too low.	Evaporator is frozen.	<ul style="list-style-type: none"> <li>Check intake sensor circuit. Refer to <a href="#">ATC-125, "Intake Sensor Circuit"</a>.</li> <li>Replace compressor.</li> <li>Repair evaporator fins.</li> <li>Replace evaporator.</li> <li>Refer to <a href="#">ATC-75, "Front Blower Motor Circuit"</a>.</li> </ul>

# TROUBLE DIAGNOSIS

## Low-pressure Side Sometimes Becomes Negative

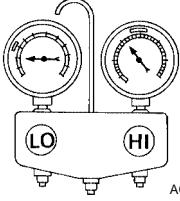
Gauge indication	Refrigerant cycle	Probable cause	Corrective action
<p>Low-pressure side sometimes becomes negative.</p>  <p style="text-align: right; font-size: small;">AC354A</p>	<ul style="list-style-type: none"> <li>● Air conditioning system does not function and does not cyclically cool the compartment air.</li> <li>● The system constantly functions for a certain period of time after compressor is stopped and restarted.</li> </ul>	<p>Refrigerant does not discharge cyclically.</p> <p>↓</p> <p>Moisture is frozen at expansion valve outlet and inlet.</p> <p>↓</p> <p>Water is mixed with refrigerant.</p>	<ul style="list-style-type: none"> <li>● Drain water from refrigerant or replace refrigerant.</li> <li>● Replace liquid tank.</li> </ul>

## Low-pressure Side Becomes Negative

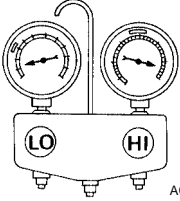
Gauge indication	Refrigerant cycle	Probable cause	Corrective action
<p>Low-pressure side becomes negative.</p>  <p style="text-align: right; font-size: small;">AC362A</p>	<p>Liquid tank or front/rear side of expansion valve's pipe is frosted or dewed.</p>	<p>High-pressure side is closed and refrigerant does not flow.</p> <p>↓</p> <p>Expansion valve or liquid tank is frosted.</p>	<p>Leave the system at rest until no frost is present. Start it again to check whether or not the malfunction is caused by water or foreign particles.</p> <ul style="list-style-type: none"> <li>● If water is the cause, initially cooling is okay. Then the water freezes causing a blockage. Drain water from refrigerant or replace refrigerant.</li> <li>● If due to foreign particles, remove expansion valve and remove the particles with dry and compressed air (not shop air).</li> <li>● If either of the above methods cannot correct the malfunction, replace expansion valve.</li> <li>● Replace liquid tank.</li> <li>● Check oil for contamination.</li> </ul>

# TROUBLE DIAGNOSIS

EJS004PD

## Insufficient Heating

SYMPTOM: Insufficient heating

### INSPECTION FLOW

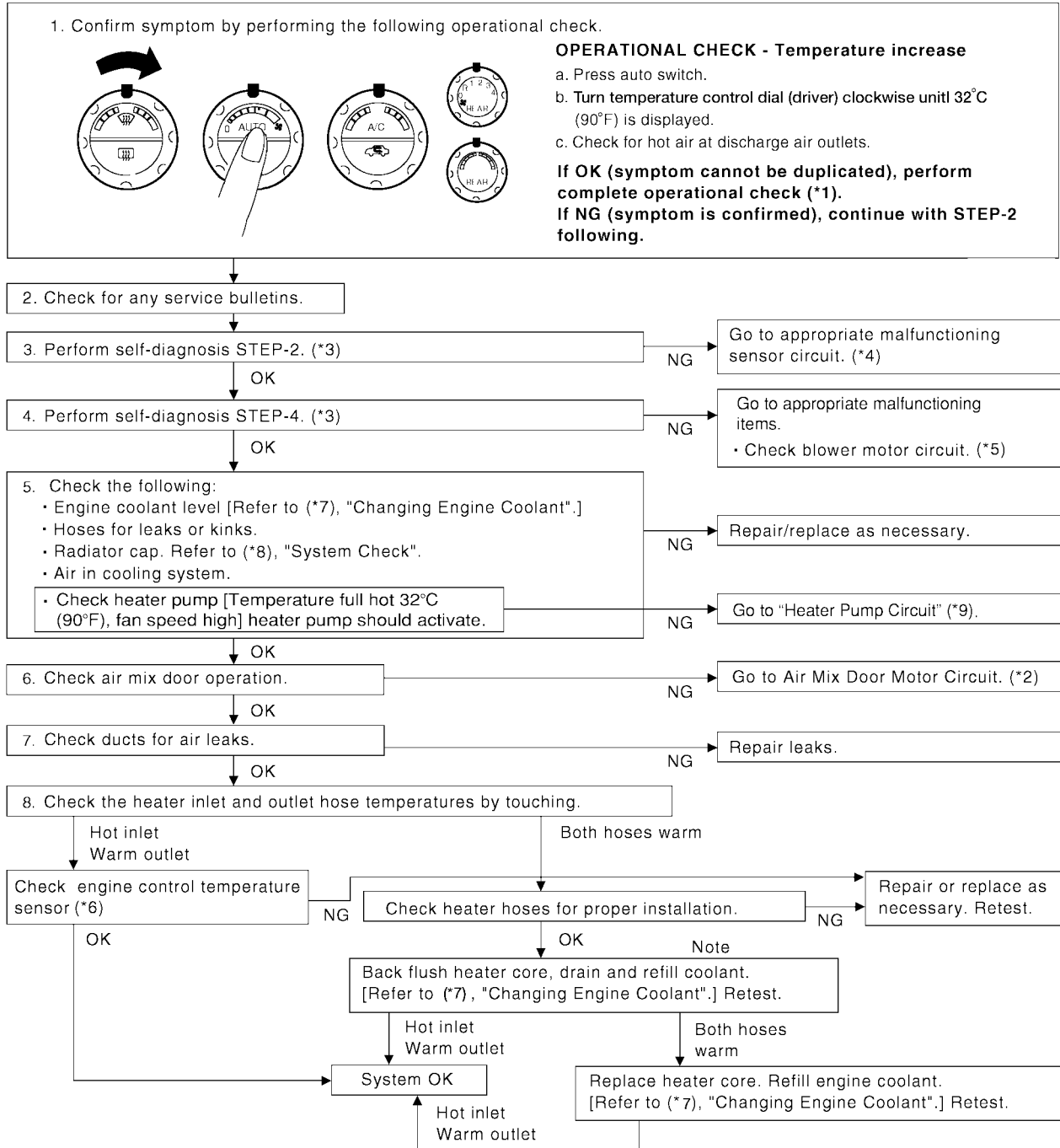

\*1 [.ATC-53, "Operational Check \(Front\)"](#) or [ATC-55, "Operational Check \(Rear\)"](#)

\*4 [ATC-52, "SELF-DIAGNOSIS CODE CHART"](#)

\*7 [MA-13, "Changing Engine Coolant"](#)

\*2 [ATC-63, "Air Mix Door Motor Circuit"](#)

\*5 [ATC-75, "Front Blower Motor Circuit"](#)

\*8 [CO-10, "CHECKING RESERVOIR CAP"](#)

\*3 [ATC-51, "A/C System Self-diagnosis Function"](#)

\*6 [EC-207, "DTC P0117, P0118 ECT SENSOR"](#)

\*9 [ATC-110, "Heater Pump Circuit"](#)

WJIA1880E

# TROUBLE DIAGNOSIS

EJS0052Q

## Heater Pump Circuit SYSTEM DESCRIPTION

### Component Parts

Heater pump control system components are:

- Front air control
- Heater pump relay
- Heater pump
- Intake sensor

### System Operation

The heater pump improves heater performance specifically at idle conditions. It is designed to operate in either of the following 2 situations:

1. Front blower motor set to maximum speed and temperature control dial (driver or passenger) set to full hot 32° C (90° F) or
2. Engine coolant temperature (signal via CAN communication) minus heater core outlet temperature (intake sensor input to front air control) is greater than 20° C (68° F). If the difference is less than 16° C (61° F), the heater pump will not operate unless the conditions in item No. 1 above are met.

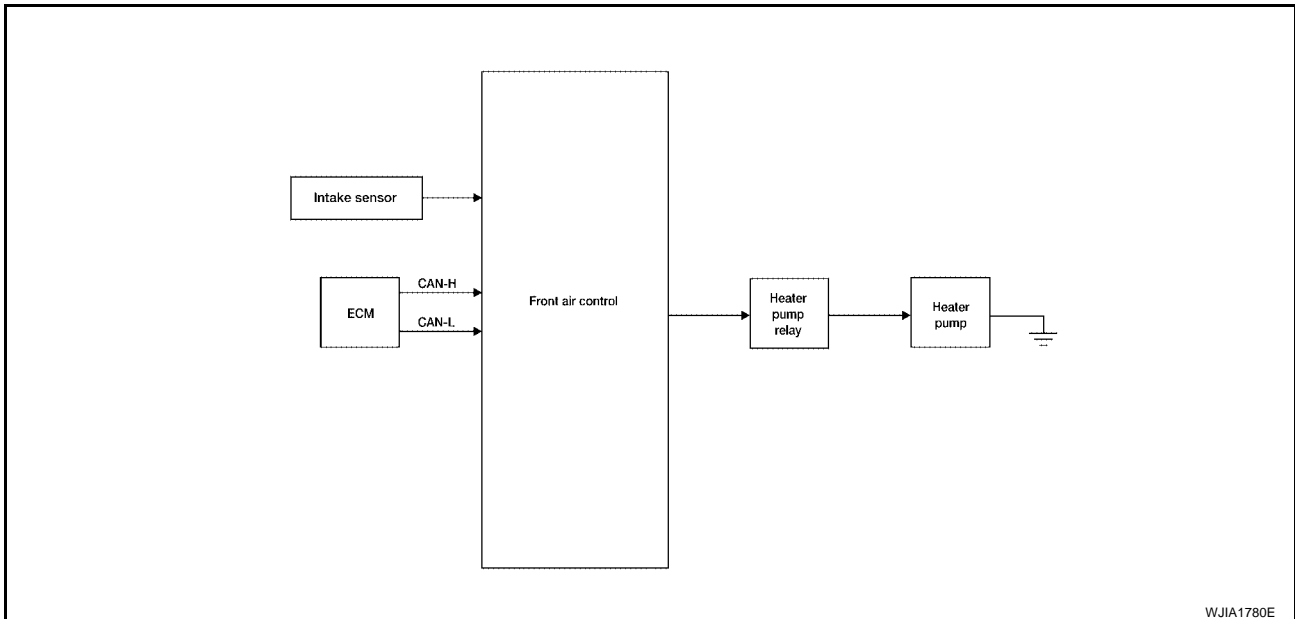

WJIA1780E

# TROUBLE DIAGNOSIS

## DIAGNOSTIC PROCEDURE FOR HEATER PUMP CIRCUIT

### 1. CHECK POWER SUPPLY TO HEATER PUMP

1. Disconnect heater pump connector.
2. Turn ignition switch ON.
3. Set front blower motor to maximum speed.
4. Turn temperature control dial (passenger or driver) to full hot 32° C (90° F).
5. Check voltage between heater pump harness connector E141 terminal 1 and ground.

**1 - Ground** : **Battery voltage**

OK or NG

- OK >> GO TO 2.  
NG >> GO TO 3.

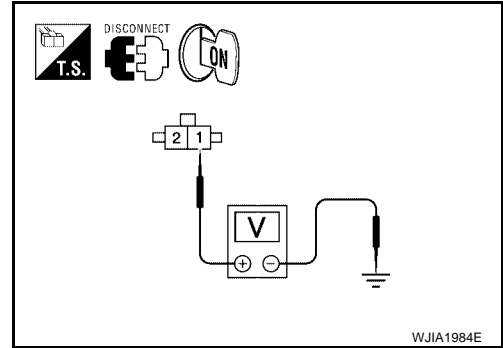

### 2. CHECK HEATER PUMP GROUND

1. Turn ignition switch OFF.
2. Check continuity between heater pump harness connector E141 terminal 2 and ground.

**2 - Ground** : **Continuity should exist.**

OK or NG

- OK >> Replace heater pump. Refer to [ATC-142, "HEATER PUMP"](#).  
NG >> Repair harness or connector.

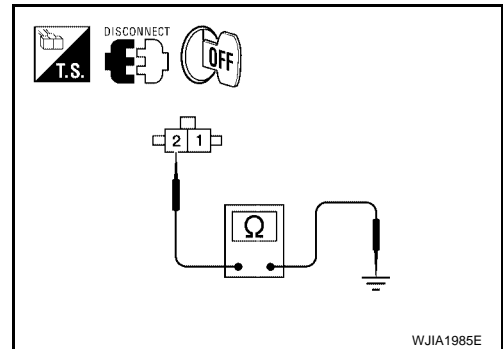

### 3. CHECK HEATER PUMP RELAY

1. Turn ignition switch OFF.
2. Check heater pump relay. Refer to [ATC-112, "Heater Pump Relay"](#).

OK or NG

- OK >> GO TO 4.  
NG >> Replace heater pump relay.

### 4. CHECK RELAY POWER SUPPLY

1. Turn ignition switch ON.
2. Check voltage between heater pump relay harness connector E144 terminals 2, 5 and ground.

**2 - Ground** : **Battery voltage**

**5 - Ground** : **Battery voltage**

OK or NG

- OK >> GO TO 5.  
NG >> Repair harness or connector.

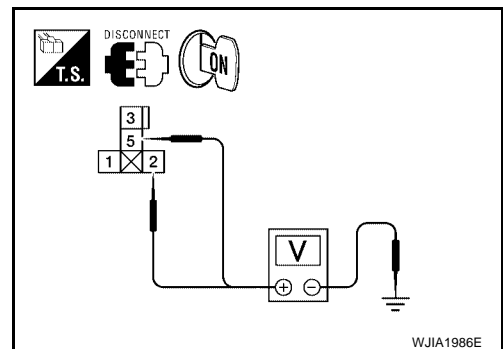

# TROUBLE DIAGNOSIS

## 5. CHECK HEATER PUMP MOTOR POWER CIRCUIT

1. Turn ignition switch OFF.
2. Check continuity between heater pump relay harness connector (A) E144 terminal 3 and heater pump harness connector (B) E141 terminal 1.

**3 - 1 : Continuity should exist.**

3. Check continuity between heater pump relay harness connector (A) E144 terminal 3 and ground.

**3 - Ground : Continuity should not exist.**

OK or NG

OK >> GO TO 6.

NG >> Repair harness or connector.

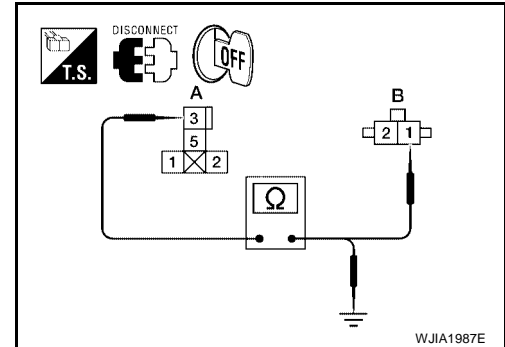

## 6. CHECK CIRCUIT BETWEEN HEATER PUMP RELAY AND FRONT AIR CONTROL

1. Disconnect front air control connector.
2. Check continuity between front air control harness connector (A) M50 terminal 44 and heater pump relay harness connector (B) E144 terminal 1.

**1 - 44 : Continuity should exist.**

3. Check continuity between heater pump relay harness connector (B) E144 terminal 1 and ground.

**1 - Ground : Continuity should not exist.**

OK or NG

OK >> Replace front air control. Refer to [ATC-127, "FRONT AIR CONTROL"](#).

NG >> Repair harness or connector.

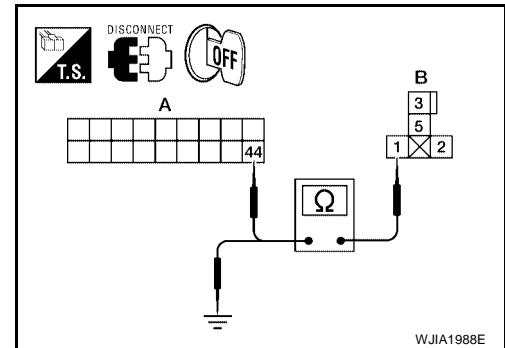

## COMPONENT INSPECTION

### Heater Pump Relay

Check continuity between terminals 3 and 5.

Conditions	Continuity
12V direct current supply between terminals 1 and 2	Yes
No current supply	No

If NG, replace relay.

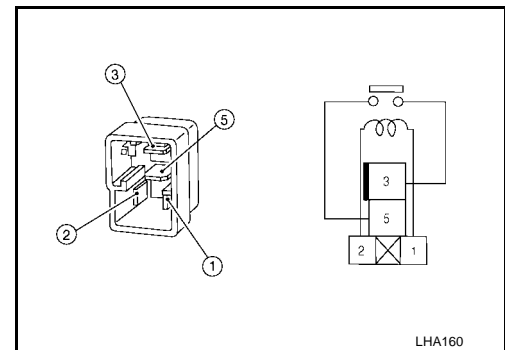



# TROUBLE DIAGNOSIS

EJS004PE

## Noise

SYMPTOM: Noise

### INSPECTION FLOW

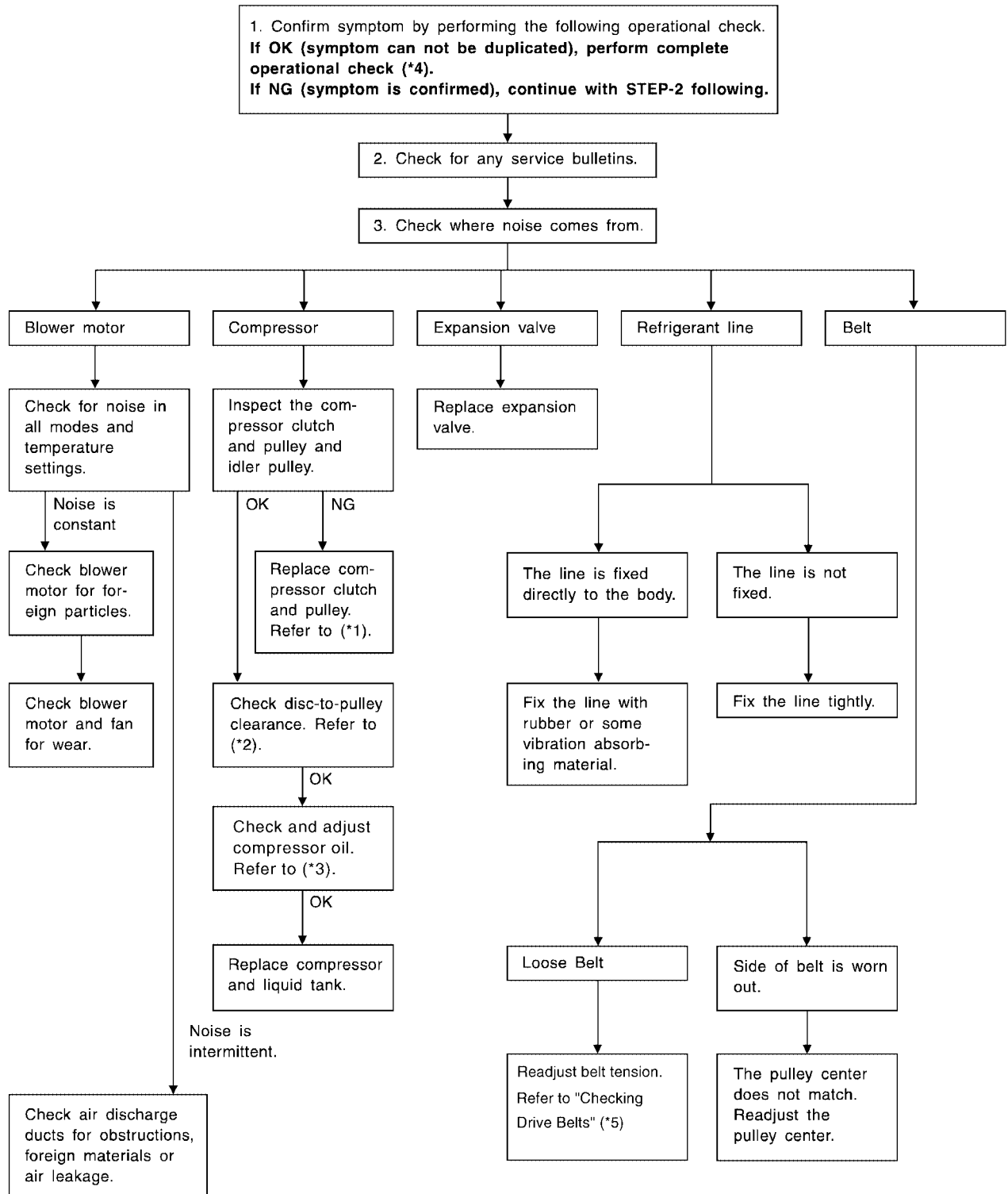

A  
B  
C  
D  
E  
F  
G  
H  
I  
K  
L  
M

ATC

WJIA1972E

## TROUBLE DIAGNOSIS

---

\*1 [ATC-159. "REMOVAL"](#)

\*2 [ATC-160. "INSTALLATION"](#)

\*3 [ATC-22. "Maintenance of Oil Quantity in Compressor"](#)

\*4 [ATC-53. "Operational Check \(Front\)"](#)  
or [ATC-55. "Operational Check \(Rear\)"](#)

\*5 [MA-13. "Checking Drive Belts"](#)

# TROUBLE DIAGNOSIS

EJS004PF

## Self-diagnosis

SYMPTOM: Self-diagnosis cannot be performed.

### INSPECTION FLOW

1. Confirm symptom by performing operational check.

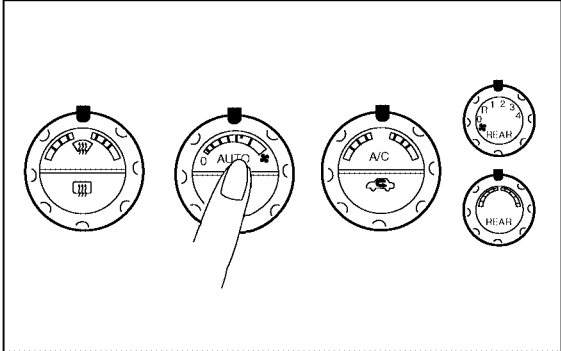

**OPERATIONAL CHECK – AUTO mode**

- Press AUTO switch.
- Display should indicate AUTO.  
(Discharge air and blower speed will depend on ambient, in-vehicle and set temperatures.)

**If OK (symptom cannot be duplicated), perform complete operational check (\*7).**  
**If NG (symptom is confirmed), continue with STEP-2 following.**

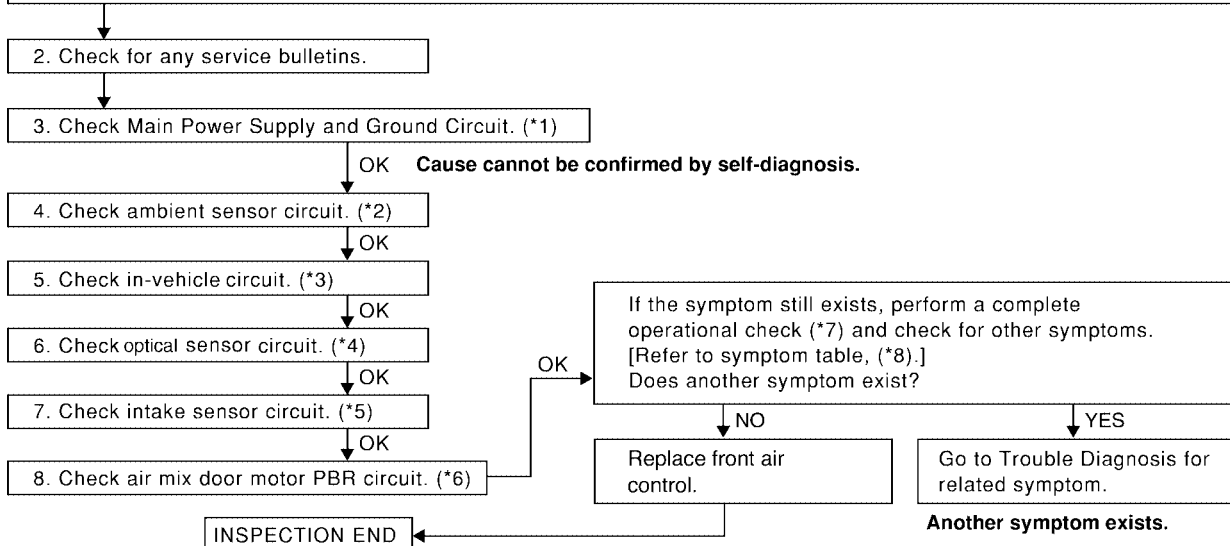

- \*1 [ATC-56, "Power Supply and Ground Circuit for Front Air Control"](#)    \*2 [ATC-117, "Ambient Sensor 1 Circuit"](#)    \*3 [ATC-120, "In-vehicle Sensor Circuit"](#)  
 \*4 [ATC-123, "Optical Sensor Circuit"](#)    \*5 [ATC-125, "Intake Sensor Circuit"](#)    \*6 [ATC-63, "Air Mix Door Motor Circuit"](#)  
 \*7 [ATC-53, "Operational Check \(Front\)"](#)    \*8 [ATC-36, "SYMPTOM TABLE"](#)

WJIA1063E

# TROUBLE DIAGNOSIS

EJS004PG

## Memory Function

SYMPTOM: Memory function does not operate.

### INSPECTION FLOW

1. Confirm symptom by performing the following operational check.

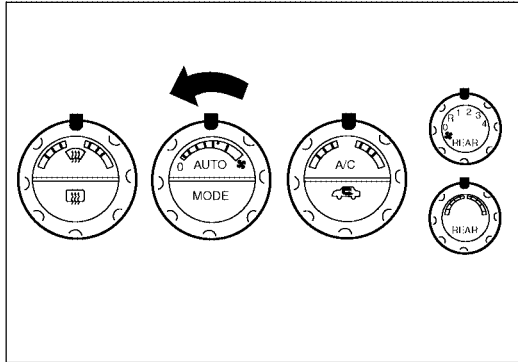

#### OPERATIONAL CHECK – Memory function

- Set the temperature to 32°C (90°F)
- Rotate the front blower control dial (driver side) to turn system off.
- Turn the ignition off.
- Turn the ignition on.
- Press the AUTO switch.
- Confirm that the set temperature remains at previous temperature.
- Press OFF switch.

**If OK (symptom cannot be duplicated), perform complete operational check (\*2).**

**If NG (symptom is confirmed), continue with STEP-2 following.**

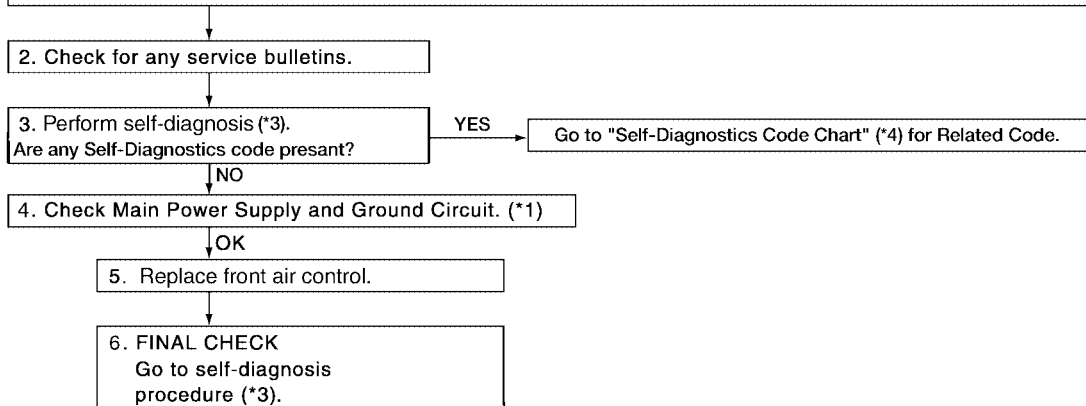

WJIA1287E

\*1 [ATC-56, "Power Supply and Ground Circuit for Front Air Control"](#) \*2 [ATC-53, "Operational Check \(Front\)"](#) \*3 [ATC-51, "A/C System Self-diagnosis Function"](#)

\*4 [ATC-52, "SELF-DIAGNOSIS CODE CHART"](#)

# TROUBLE DIAGNOSIS

EJS004PH

## Ambient Sensor 1 Circuit COMPONENT DESCRIPTION

### Ambient Sensor 1

Ambient sensor 1 (1) is attached to the radiator core support (left side). It detects ambient temperature and converts it into a value which is then input into the front air control.

- ←: Front

#### NOTE:

Both of the ambient sensors are located behind the front grille, below the hood latch. The upper ambient sensor 1 (1) provides input for the automatic A/C system. The lower ambient sensor 2 (2) provides input for the compass/temperature driver information system.

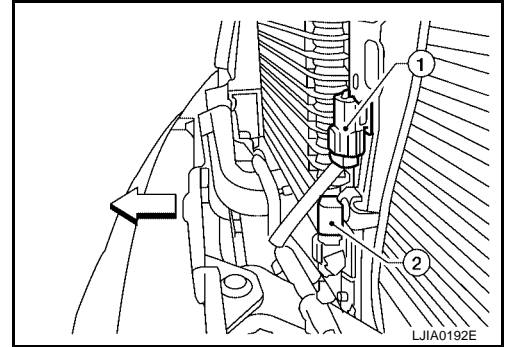

### AMBIENT TEMPERATURE INPUT PROCESS

The front air control includes a processing circuit for ambient sensor 1 input. However, when the temperature detected by ambient sensor 1 increases quickly, the processing circuit retards the front air control function. It only allows the front air control to recognize an ambient temperature increase of 0.33°C (0.6°F) per 100 seconds.

This prevents constant adjustments due to momentary conditions, such as stopping after high speed driving. Although the actual ambient temperature has not changed, the temperature detected by ambient sensor 1 will increase. This is because the heat from the engine compartment can radiate to the front grille area, location of ambient sensor 1.

### DIAGNOSTIC PROCEDURE FOR AMBIENT SENSOR 1

SYMPTOM: Ambient sensor 1 circuit is open or shorted. [40 or 41 is indicated on the navi screen (only if equipped) as a result of conducting the front air control self-diagnosis].

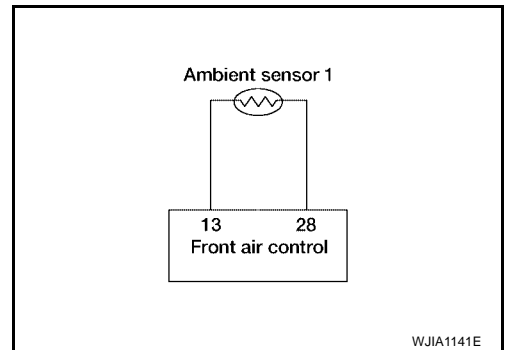

## 1. CHECK VOLTAGE BETWEEN AMBIENT SENSOR 1 AND GROUND

1. Disconnect ambient sensor 1 connector.
2. Turn ignition switch ON.
3. Check voltage between ambient sensor 1 harness connector E1 terminal 1 and ground.

1 - Ground

: Approx. 5V

OK or NG

- OK >> GO TO 2.
- NG >> GO TO 4.

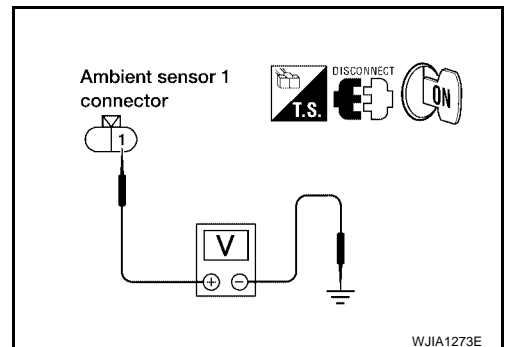

# TROUBLE DIAGNOSIS

## 2. CHECK CIRCUIT CONTINUITY BETWEEN AMBIENT SENSOR 1 AND FRONT AIR CONTROL

1. Turn ignition switch OFF.
2. Disconnect front air control connector.
3. Check continuity between ambient sensor 1 harness connector E1 terminal 2 and front air control harness connector M49 terminal 13.

**2 - 13 : Continuity should exist.**

OK or NG

- OK >> GO TO 3.  
 NG >> Repair harness or connector.

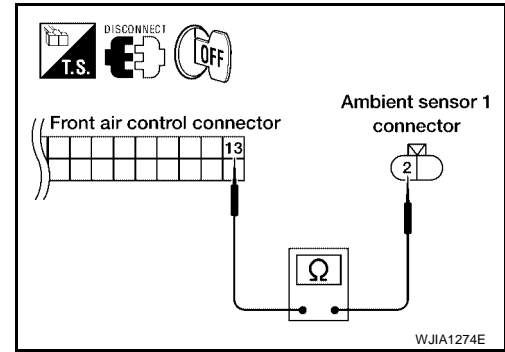

## 3. CHECK AMBIENT SENSOR 1

Check ambient sensor 1. Refer to [ATC-119, "Ambient Sensor 1"](#) .

OK or NG

- OK >> 1. Replace front air control. Refer to [ATC-127, "FRONT AIR CONTROL"](#) .  
 2. Go to [ATC-51, "A/C System Self-diagnosis Function"](#) and perform self-diagnosis.
- NG >> 1. Replace ambient sensor 1. Refer to [ATC-128, "AMBIENT SENSOR"](#) .  
 2. Go to [ATC-51, "A/C System Self-diagnosis Function"](#) and perform self-diagnosis.

## 4. CHECK CIRCUIT CONTINUITY BETWEEN AMBIENT SENSOR 1 AND FRONT AIR CONTROL

1. Turn ignition switch OFF.
2. Disconnect front air control connector.
3. Check continuity between ambient sensor 1 harness connector E1 (B) terminal 1 and front air control harness connector M50 (A) terminal 28.

A		B		Continuity
Connector	Terminal	Connector	Terminal	
Front air control: M50	28	Ambient sensor 1: E1	1	Yes

4. Check continuity between ambient sensor 1 harness connector E1 terminal 2 and ground.

B		Continuity
Connector	Terminal	
Ambient Sensor 1: E1	1	No

OK or NG

- OK >> 1. Replace front air control. Refer to [ATC-127, "FRONT AIR CONTROL"](#) .  
 2. Go to [ATC-51, "A/C System Self-diagnosis Function"](#) and perform self-diagnosis.
- NG >> Repair harness or connector.

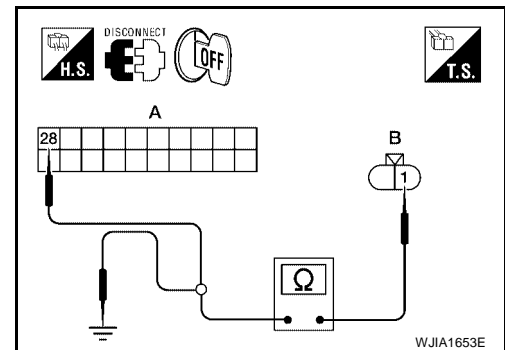

# TROUBLE DIAGNOSIS

## COMPONENT INSPECTION

### Ambient Sensor 1

After disconnecting ambient sensor 1 (1) connector E1, measure resistance between terminals 1 and 2 at sensor component side, using the table below.

- ←: Front

#### NOTE:

Both of the ambient sensors are located behind the front grille, below the hood latch. The upper ambient sensor 1 (1) provides input for the automatic A/C system. The lower ambient sensor 2 (2) provides input for the compass/temperature driver information system.

Temperature °C (°F)	Resistance kΩ
-15 (5)	12.73
-10 (14)	9.92
-5 (23)	7.80
0 (32)	6.19
5 (41)	4.95
10 (50)	3.99
15 (59)	3.24
20 (68)	2.65
25 (77)	2.19
30 (86)	1.81
35 (95)	1.51
40 (104)	1.27
45 (113)	1.07

If NG, replace ambient sensor 1.

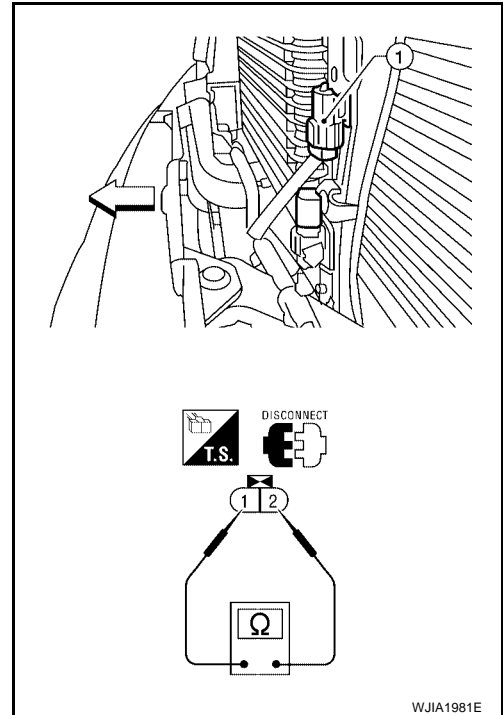

A  
B  
C  
D  
E  
F  
G  
H  
I

ATC

K  
L  
M

# TROUBLE DIAGNOSIS

EJS004PI

## In-vehicle Sensor Circuit COMPONENT DESCRIPTION

### In-vehicle Sensor

The in-vehicle sensor is located on cluster lid D. It converts variations in temperature of passenger compartment air (drawn in through the integrated fan) into a resistance value. It is then input into the front air control.

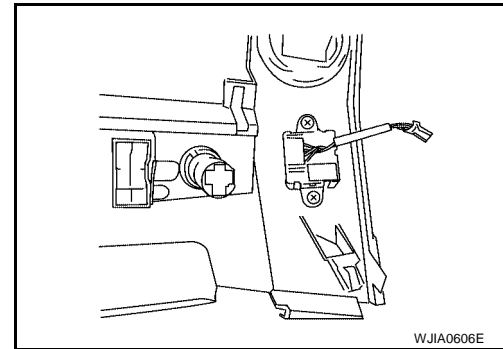
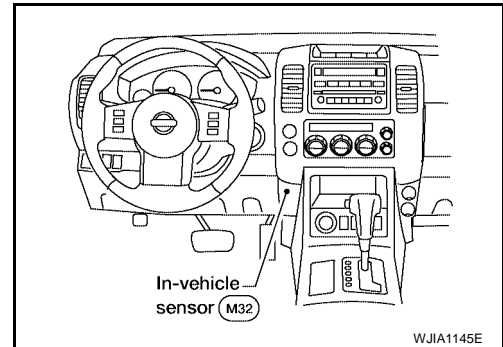

## DIAGNOSTIC PROCEDURE FOR IN-VEHICLE SENSOR

SYMPTOM: In-vehicle sensor circuit is out of range. (30 or 31 is indicated on front air control display as a result of conducting self-diagnosis.)

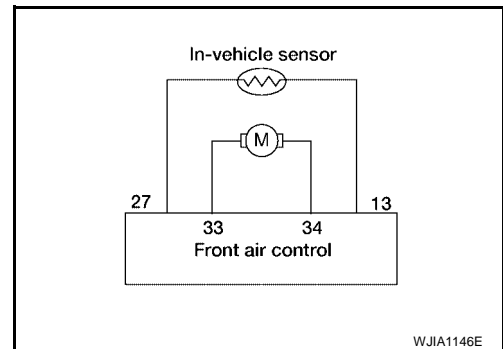

### 1. CHECK IN-VEHICLE SENSOR CIRCUIT

Is self-diagnostic codes 30 or 31 present? Refer to [ATC-51, "A/C System Self-diagnosis Function"](#).

YES or NO

- YES >> GO TO 2.
- NO >> GO TO 6.



# TROUBLE DIAGNOSIS

## 2. CHECK VOLTAGE BETWEEN IN-VEHICLE SENSOR AND GROUND

1. Disconnect in-vehicle sensor connector.
2. Turn ignition switch ON.
3. Check voltage between in-vehicle sensor harness connector M32 terminal 4 and ground.

**4 - Ground** : **Approx. 5V.**

OK or NG

- OK >> GO TO 3.  
NG >> GO TO 5.

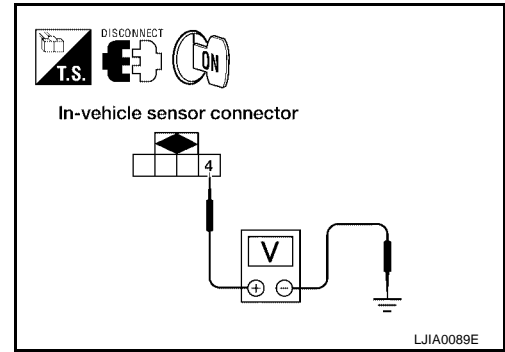

## 3. CHECK CIRCUIT CONTINUITY BETWEEN IN-VEHICLE SENSOR AND FRONT AIR CONTROL

1. Turn ignition switch OFF.
2. Disconnect front air control connector M49.
3. Check continuity between in-vehicle sensor harness connector M32 terminal 1 and front air control harness connector M49 terminal 13.

**1 - 13** : **Continuity should exist.**

OK or NG

- OK >> GO TO 4.  
NG >> Repair harness or connector.

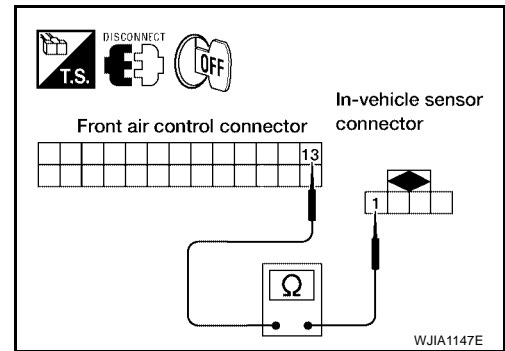

## 4. CHECK IN-VEHICLE SENSOR

Check in-vehicle sensor. Refer to [ATC-122, "In-vehicle Sensor"](#) .

OK or NG

- OK >> 1. Replace front air control. Refer to [ATC-127, "FRONT AIR CONTROL"](#) .  
2. Go to [ATC-51, "A/C System Self-diagnosis Function"](#) and perform self-diagnosis.
- NG >> 1. Replace in-vehicle sensor. Refer to [ATC-129, "IN-VEHICLE SENSOR"](#) .  
2. Go to [ATC-51, "A/C System Self-diagnosis Function"](#) and perform self-diagnosis.

## 5. CHECK CIRCUIT CONTINUITY BETWEEN IN-VEHICLE SENSOR AND FRONT AIR CONTROL

1. Turn ignition switch OFF.
2. Disconnect front air control connector.
3. Check continuity between in-vehicle sensor harness connector M32 terminal 4 and front air control harness connector M50 terminal 27.

**4 - 27** : **Continuity should exist.**

4. Check continuity between in-vehicle sensor harness connector M32 terminal 4 and ground.

**4 - Ground** : **Continuity should not exist.**

OK or NG

- OK >> 1. Replace front air control. Refer to [ATC-127, "FRONT AIR CONTROL"](#) .  
2. Go to [ATC-51, "A/C System Self-diagnosis Function"](#) and perform self-diagnosis.
- NG >> Repair harness or connector.

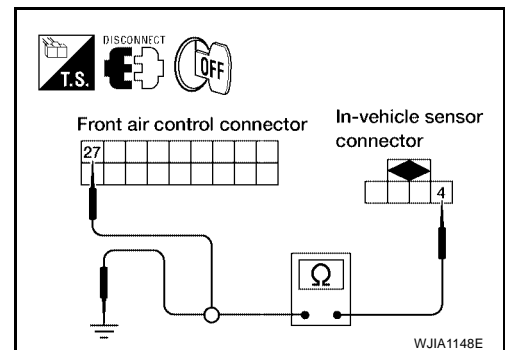

# TROUBLE DIAGNOSIS

## 6. CHECK CIRCUIT CONTINUITY BETWEEN IN-VEHICLE SENSOR MOTOR AND FRONT AIR CONTROL

1. Turn ignition switch OFF.
2. Disconnect front air control connector and in-vehicle sensor connector.
3. Check continuity between in-vehicle sensor harness connector M32 terminal 2 and 3 and front air control harness connector M50 terminal 34 and 33.

**2 - 34 : Continuity should exist.**

**3 - 33 : Continuity should exist.**

4. Check continuity between in-vehicle sensor harness connector M32 terminal 2 and 3 and ground.

**2, 3 - Ground : Continuity should not exist.**

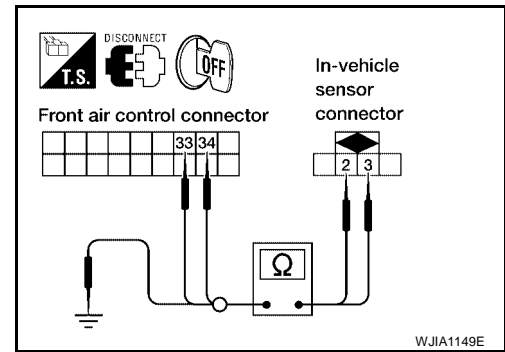

OK or NG

- OK >> 1. Replace in-vehicle sensor. Refer to [ATC-129, "IN-VEHICLE SENSOR"](#) .  
 2. Go to [ATC-51, "A/C System Self-diagnosis Function"](#) and perform self-diagnosis.  
 3. Replace front air control. Refer to [ATC-127, "FRONT AIR CONTROL"](#) .  
 4. Go to [ATC-51, "A/C System Self-diagnosis Function"](#) and perform self-diagnosis.

NG >> Repair harness or connector.

### COMPONENT INSPECTION

#### In-vehicle Sensor

After disconnecting in-vehicle sensor connector M32, measure resistance between terminals 1 and 4 at sensor component side, using the table below.

Temperature °C (°F)	Resistance kΩ
-15 (5)	21.40
-10 (14)	16.15
-5 (23)	12.29
0 (32)	9.41
5 (41)	7.27
10 (50)	5.66
15 (59)	4.45
20 (68)	3.51
25 (77)	2.79
30 (86)	2.24
35 (95)	1.80
40 (104)	1.45
45 (113)	1.18

If NG, replace in-vehicle sensor.

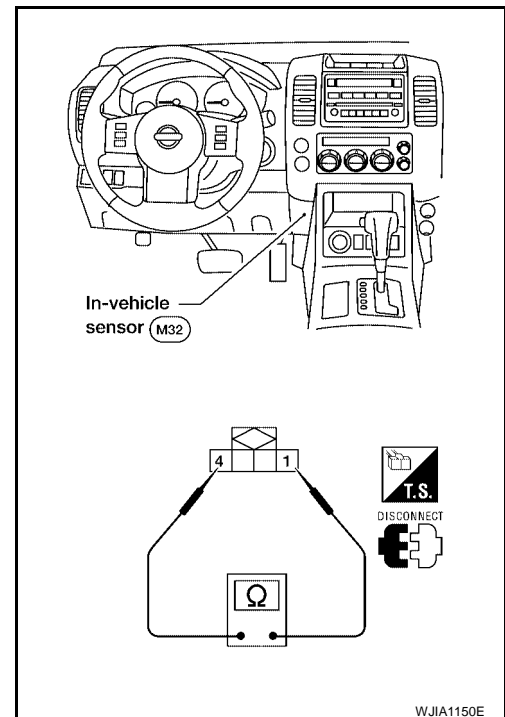

# TROUBLE DIAGNOSIS

## Optical Sensor Circuit COMPONENT DESCRIPTION

EJS004PJ

The optical sensor is located in the center of the defroster grille. It detects sunload entering through windshield by means of a photo diode. The sensor converts the sunload into a current value which is then input into the front air control.

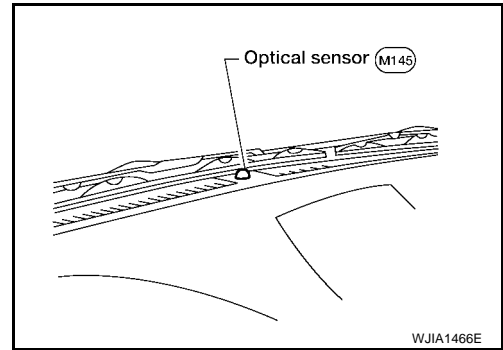

## OPTICAL INPUT PROCESS

The front air control includes a processing circuit which averages the variations in detected sunload over a period of time. This prevents adjustments in the ATC system operation due to small or quick variations in detected sunload.

For example, consider driving along a road bordered by an occasional group of large trees. The sunload detected by the optical sensor will vary whenever the trees obstruct the sunlight. The processing circuit averages the detected sunload over a period of time, so that the (insignificant) effect of the trees momentarily obstructing the sunlight does not cause any change in the ATC system operation. On the other hand, shortly after entering a long tunnel, the system will recognize the change in sunload, and the system will react accordingly.

## DIAGNOSTIC PROCEDURE FOR OPTICAL SENSOR

SYMPTOM: Optical sensor circuit is open or shorted. (50 or 52 is indicated on front air control display as a result of conducting self-diagnosis).

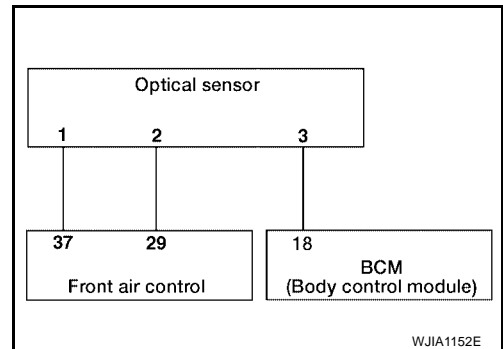

A  
B  
C  
D  
E  
F  
G  
H  
I  
J  
K  
L  
M

ATC

# TROUBLE DIAGNOSIS

## 1. CHECK CIRCUIT CONTINUITY BETWEEN OPTICAL SENSOR AND FRONT AIR CONTROL

1. Turn ignition switch OFF.
2. Disconnect front air control connector and optical sensor connector.
3. Check continuity between optical sensor harness connector M145 (B) terminal 1 and 2 and front air control harness connector M50 (A) terminal 37 and 29.

A		B		
Connector	Terminal	Connector	Terminal	Continuity
Front air control: M50	29	Optical sensor: M145	2	Yes
Front air control: M50	37	Optical sensor: M145	1	Yes

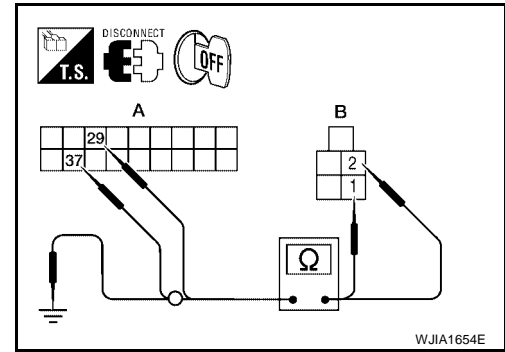

4. Check continuity between optical sensor harness connector M145 (B) terminal 1 and 2 and ground.

B			Continuity
Connector	Terminal	Ground	
Optical sensor: M145	1		No
Optical sensor: M145	2		No

OK or NG

- OK >> GO TO 2.
- NG >> Repair harness or connector.

## 2. CHECK CIRCUIT CONTINUITY BETWEEN OPTICAL SENSOR AND BCM

1. Turn ignition switch OFF.
2. Disconnect BCM connector and optical sensor connector.
3. Check continuity between optical sensor harness connector M145 (B) terminal 3 and BCM harness connector M18 (A) terminal 18.

A		B		
Connector	Terminal	Connector	Terminal	Continuity
BCM: M18	18	Optical sensor: M145	3	Yes

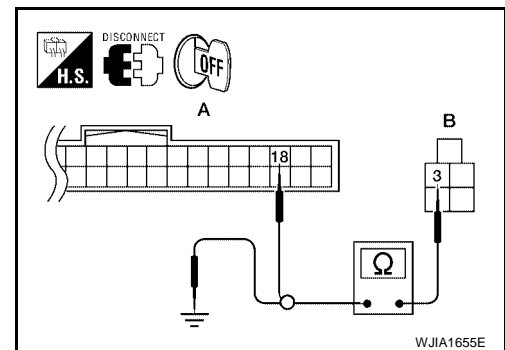

4. Check continuity between optical sensor harness connector M145 (B) terminal 3 and ground.

B			Continuity
Connector	Terminal	Ground	
Optical Sensor: M145	3		No

OK or NG

- OK >> Replace optical sensor. Refer to [ATC-130, "OPTICAL SENSOR"](#).
- NG >> Repair harness or connector.

# TROUBLE DIAGNOSIS

EJS004PK

## Intake Sensor Circuit COMPONENT DESCRIPTION

### Intake Sensor

The intake sensor is located on the heater & cooling unit assembly. It converts temperature of air after it passes through the evaporator into a resistance value which is then input to the front air control.

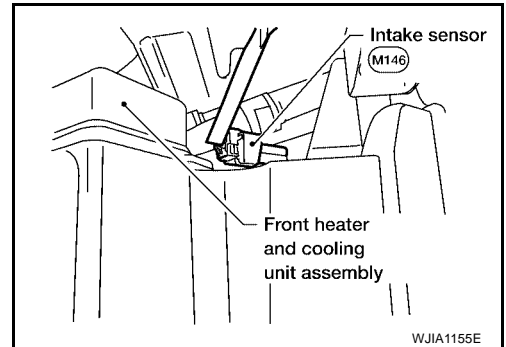

## DIAGNOSTIC PROCEDURE FOR INTAKE SENSOR

SYMPTOM: Intake sensor circuit is open or shorted. (56 or 57 is indicated on front air control display as a result of conducting Self-diagnosis.)

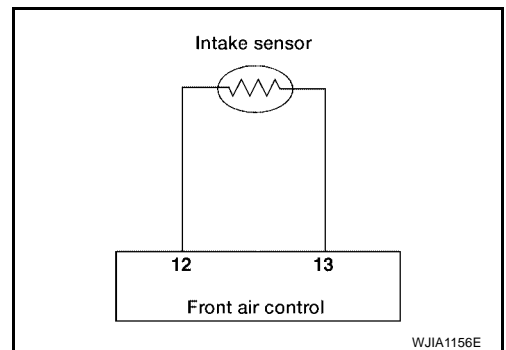

### 1. CHECK VOLTAGE BETWEEN INTAKE SENSOR AND GROUND

1. Disconnect intake sensor connector.
2. Turn ignition switch ON.
3. Check voltage between intake sensor harness connector M146 terminal 2 and ground.

**2 - Ground : Approx. 5V**

OK or NG

- OK >> GO TO 2.
- NG >> GO TO 4.

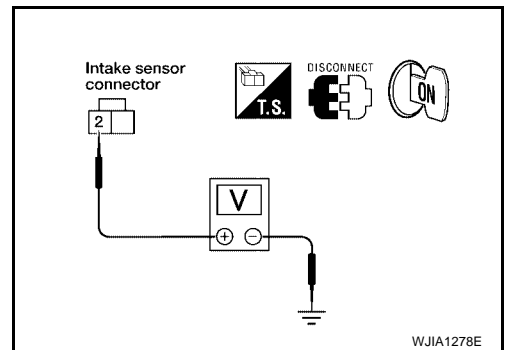

### 2. CHECK CIRCUIT CONTINUITY BETWEEN INTAKE SENSOR AND FRONT AIR CONTROL

1. Turn ignition switch OFF.
2. Disconnect front air control connector.
3. Check continuity between intake sensor harness connector M146 terminal 1 and front air control harness connector M49 terminal 13.

**1 - 13 : Continuity should exist.**

OK or NG

- OK >> GO TO 3.
- NG >> Repair harness or connector.

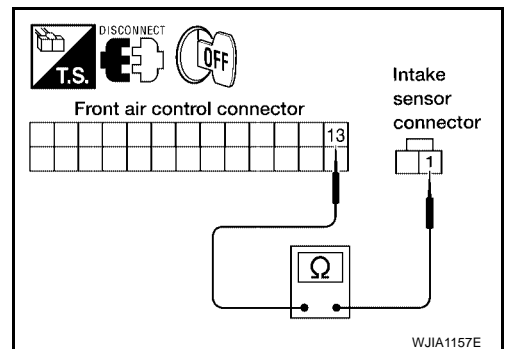

A  
B  
C  
D  
E  
F  
G  
H  
I  
ATC  
K  
L  
M

# TROUBLE DIAGNOSIS

## 3. CHECK INTAKE SENSOR

Refer to [ATC-126, "Intake Sensor"](#) .

OK or NG

- OK >> 1. Replace front air control. Refer to [ATC-127, "FRONT AIR CONTROL"](#) .  
 2. Go to [ATC-51, "A/C System Self-diagnosis Function"](#) and perform self-diagnosis.
- NG >> 1. Replace intake sensor. Refer to [ATC-131, "INTAKE SENSOR"](#) .  
 2. Go to [ATC-51, "A/C System Self-diagnosis Function"](#) and perform self-diagnosis.

## 4. CHECK CIRCUIT CONTINUITY BETWEEN INTAKE SENSOR AND FRONT AIR CONTROL

- Turn ignition switch OFF.
- Disconnect front air control connector.
- Check continuity between intake sensor harness connector M146 terminal 2 and front air control harness connector M49 terminal 12.

**2 - 12** : Continuity should exist.

- Check continuity between intake sensor harness connector M146 terminal 2 and ground.

**2 - Ground** : Continuity should not exist.

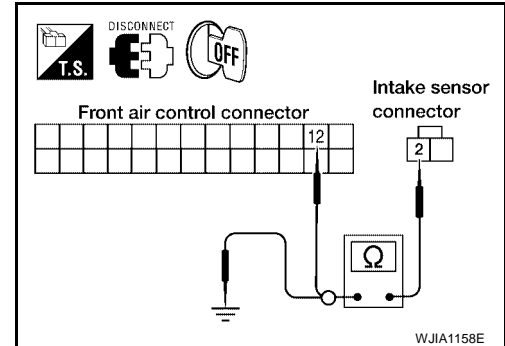

OK or NG

- OK >> 1. Replace front air control. Refer to [ATC-127, "FRONT AIR CONTROL"](#) .  
 2. Go to [ATC-51, "A/C System Self-diagnosis Function"](#) and perform self-diagnosis.
- NG >> Repair harness or connector.

## COMPONENT INSPECTION

### Intake Sensor

After disconnecting intake sensor connector, measure resistance between terminals 1 and 2 at sensor harness side, using the table below.

Temperature °C (°F)	Resistance kΩ
-15 (5)	209.0
-10 (14)	160.0
-5 (23)	123.0
0 (32)	95.8
5 (41)	74.9
10 (50)	58.9
15 (59)	46.7
20 (68)	37.3
25 (77)	30.0
30 (86)	24.2
35 (95)	19.7
40 (104)	16.1
45 (113)	13.2

If NG, replace intake sensor.

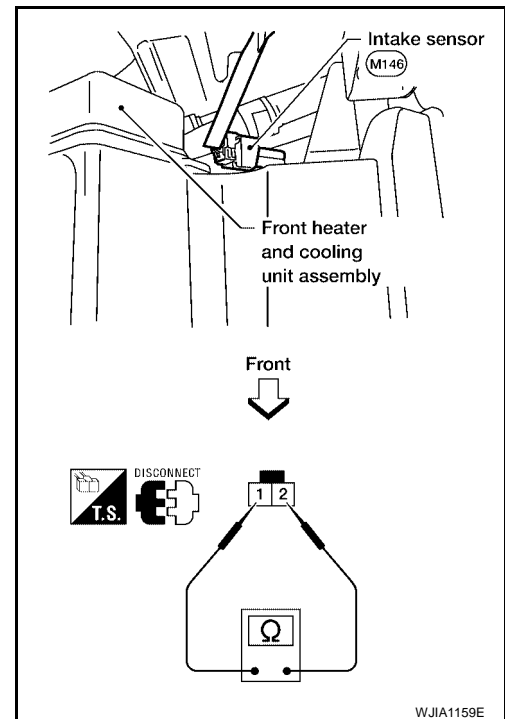

# CONTROL UNIT

PFP:27500

EJS004PL

## CONTROL UNIT

### Removal and Installation FRONT AIR CONTROL

#### Removal

1. Remove cluster lid C. Refer to [IP-11, "CLUSTER LID C -WITHOUT NAVIGATION SYSTEM"](#) .
2. Remove the four screws securing the front air control to cluster lid C.
3. Remove the front air control.

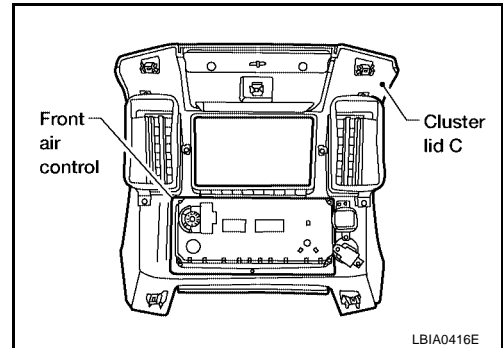

#### Installation

Installation is in the reverse order of removal.

### REAR AIR CONTROL

#### Removal

1. Remove the rear finisher assembly from the back of the center console. Refer to [IP-16, "CENTER CONSOLE"](#) .
2. Remove the four screws and remove the rear air control.

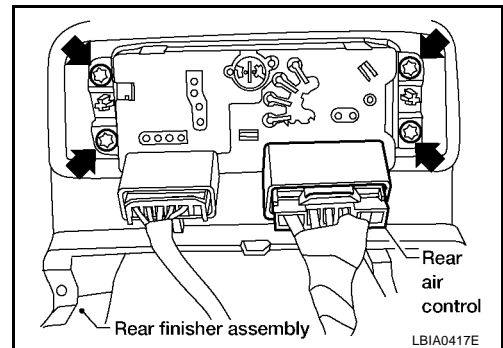

#### Installation

Installation is in the reverse order of removal.

A  
B  
C  
D  
E  
F  
G  
H  
I  
ATC  
K  
L  
M

# AMBIENT SENSOR

PF2:27722

## AMBIENT SENSOR

### Removal and Installation

EJS004PM

#### REMOVAL

1. Remove the front grille. Refer to [EI-16, "FRONT GRILLE"](#) .
2. Disconnect the ambient sensor 1 (1) electrical connector.

- ←: Front

#### NOTE:

Both of the ambient sensors are located behind the front grille, below the hood latch. The upper ambient sensor 1 (1) provides input for the automatic A/C system. The lower ambient sensor 2 (2) provides input for the compass/temperature driver information system.

3. Release the ambient sensor 1 (1) clip and then remove the ambient sensor 1 (1).

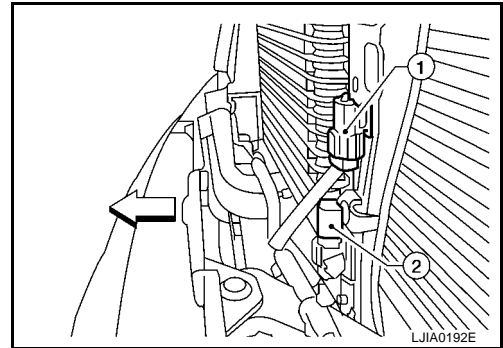

#### INSTALLATION

Installation is in the reverse order of removal.



# IN-VEHICLE SENSOR

## IN-VEHICLE SENSOR

PFP:27720

### Removal and Installation

EJS004PN

#### REMOVAL

1. Remove the cluster lid D. Refer to [IP-13, "CLUSTER LID D"](#).
2. Remove the two screws and remove the in-vehicle sensor.

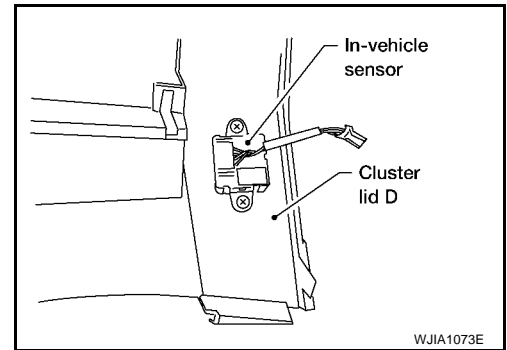

#### INSTALLATION

Installation is in the reverse order of removal.

A  
B  
C  
D  
E  
F  
G  
H  
I  
K  
L  
M

ATC

# OPTICAL SENSOR

## OPTICAL SENSOR

PF2:28576

### Removal and Installation

EJS004PO

The optical sensor is located in the top center of the instrument panel. Refer to [LT-55, "Removal and Installation"](#) .

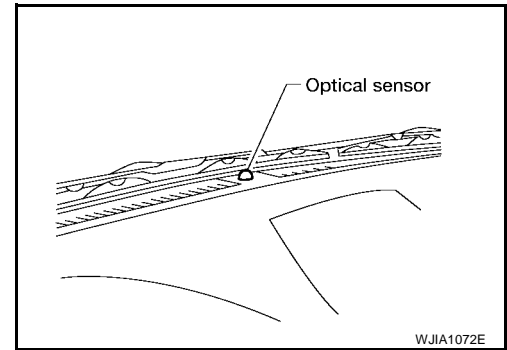

# INTAKE SENSOR

## INTAKE SENSOR

PF2:27723

### Removal and Installation

EJS004PP

#### REMOVAL

1. Remove the front kick plate. Refer to [EI-28, "KICK PLATES"](#) .
2. Remove the lower dash side finisher. Refer to [EI-28, "LOWER DASH SIDE FINISHER"](#) .
3. Remove the front pillar lower finisher. Refer to [EI-28, "FRONT PILLAR LOWER FINISHER"](#) .
4. Remove the assist grip handle.
5. Remove the front pillar upper finisher. Refer to [EI-28, "FRONT PILLAR UPPER FINISHER"](#) .
6. Remove the lower glove box. Refer to [IP-15, "LOWER INSTRUMENT PANEL RH AND LOWER GLOVE BOX"](#) .
7. Remove the upper glove box (cluster lid E). Refer to [IP-10, "INSTRUMENT PANEL"](#) .
8. Disconnect the intake sensor electrical connector.

#### NOTE:

The intake sensor is located on the top of the front heater and cooling unit assembly next to the A/C evaporator cover.

9. Twist the intake sensor to remove the intake sensor from the front heater and cooling unit assembly.

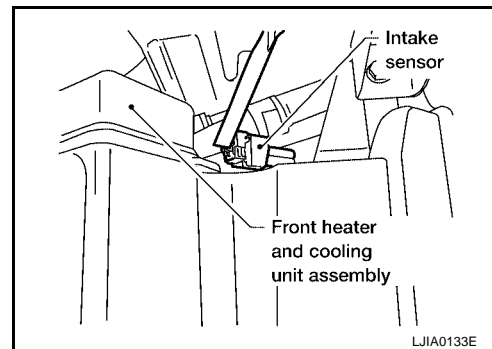

#### INSTALLATION

Installation is in the reverse order of removal.

A

B

C

D

E

F

G

H

I

ATC

K

L

M

# BLOWER MOTOR

PFP:27226

EJS004PQ

## BLOWER MOTOR

### Components

#### Front Blower Motor

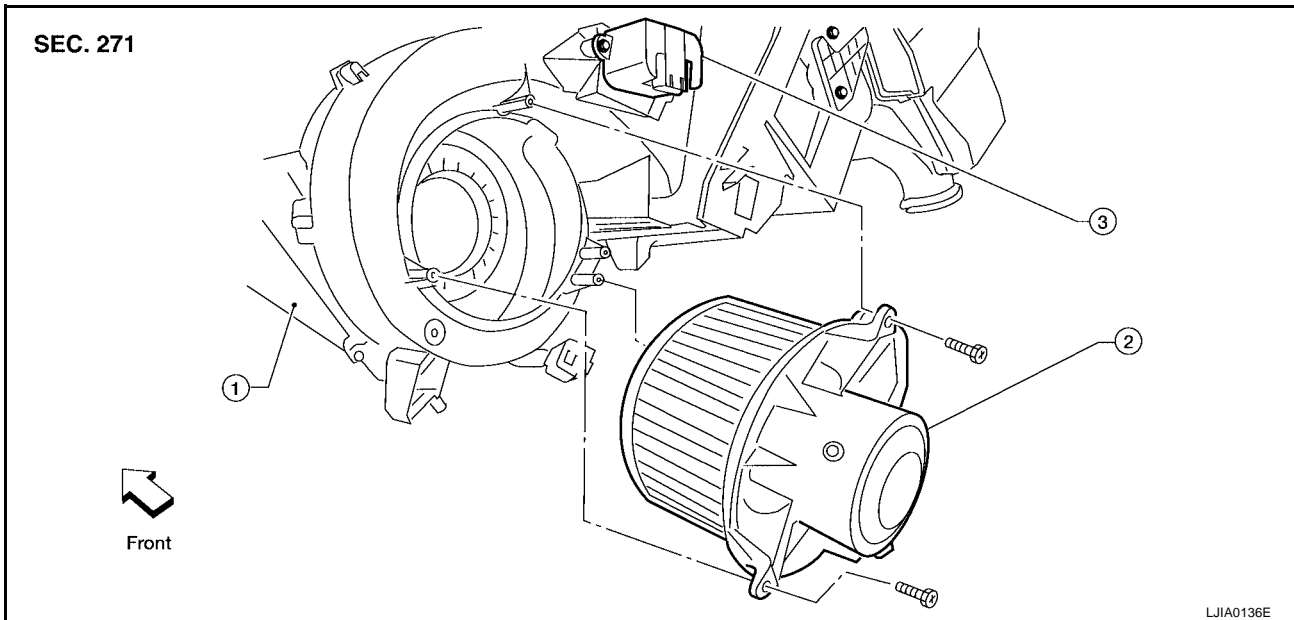

1. Front heater and cooling unit assembly      2. Front blower motor      3. Variable blower control

#### Rear Blower Motor

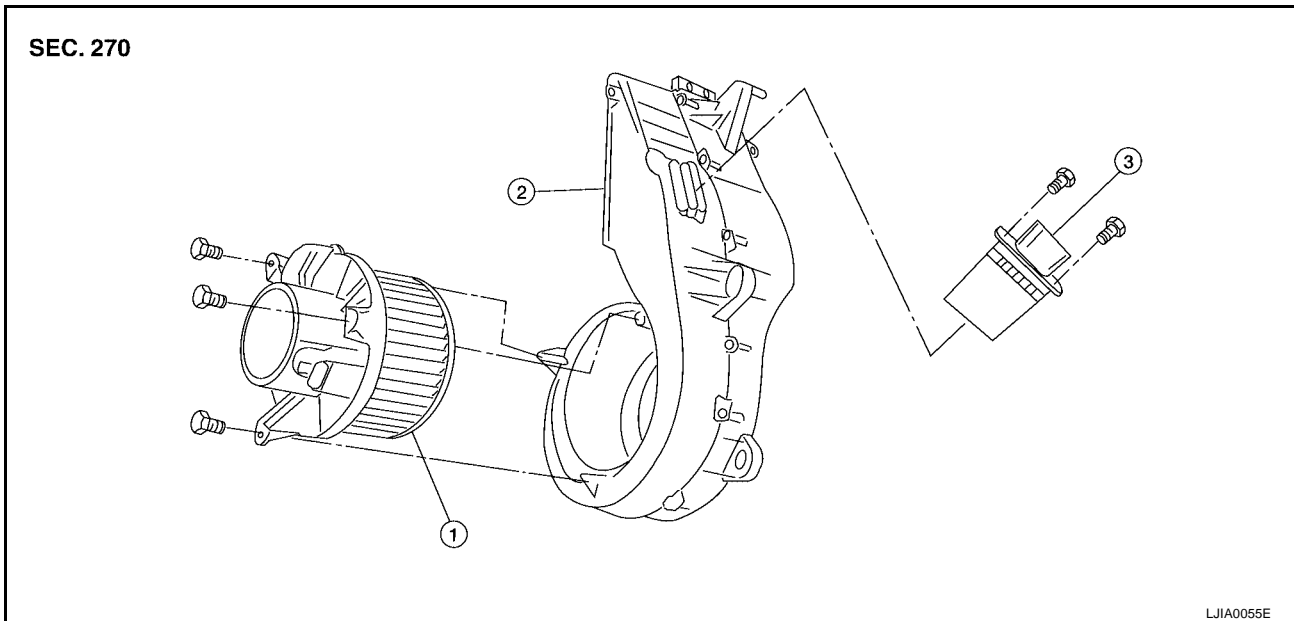

1. Rear blower motor      2. Rear blower motor case      3. Rear blower motor resistor

## Removal and Installation

### FRONT BLOWER MOTOR

EJS004PR

#### Removal

1. Remove the lower glove box assembly. Refer to [IP-15, "LOWER INSTRUMENT PANEL RH AND LOWER GLOVE BOX"](#).
2. Disconnect the front blower motor electrical connector.
3. Remove the three screws and remove the front blower motor.

#### Installation

Installation is in the reverse order of removal.

# BLOWER MOTOR

---

## REAR BLOWER MOTOR

### Removal

1. Remove the rear heater and cooling unit assembly. Refer to [ATC-138, "REAR HEATER AND COOLING UNIT ASSEMBLY"](#).
2. Disconnect the rear blower motor electrical connector.
3. Remove the three screws and remove the rear blower motor.

### Installation

Installation is in the reverse order of removal.

A

B

C

D

E

F

G

H

I

ATC

K

L

M

# IN-CABIN MICROFILTER

## IN-CABIN MICROFILTER

PFP:27277

### Removal and Installation FUNCTION

EJS004PS

The air inside the passenger compartment is filtered by the in-cabin microfilters when the heater or A/C controls are set on either the recirculation or fresh mode. The two in-cabin microfilters are located in the front heater and cooling unit assembly. The rear heater and cooling unit assembly only draws in air from the passenger compartment to recirculate into the passenger compartment, so the rear heater and cooling unit assembly is not equipped with in-cabin microfilters.

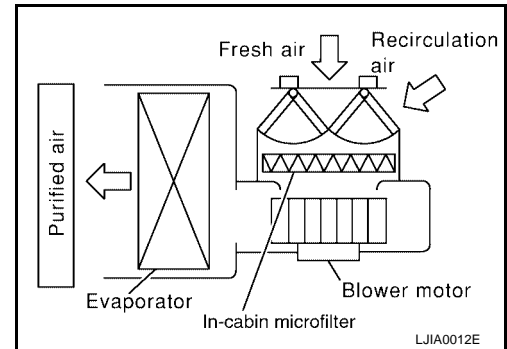

### REPLACEMENT TIMING

Replacement of the two in-cabin microfilters is recommended on a regular interval depending on the driving conditions. Refer to [MA-7, "PERIODIC MAINTENANCE"](#). It may also be necessary to replace the two in-cabin microfilters as part of a component replacement if the in-cabin microfilters are damaged.

### REPLACEMENT PROCEDURE

1. Open the lower glove box and press in on the sides so that it will open completely allowing it to hang by the cord.

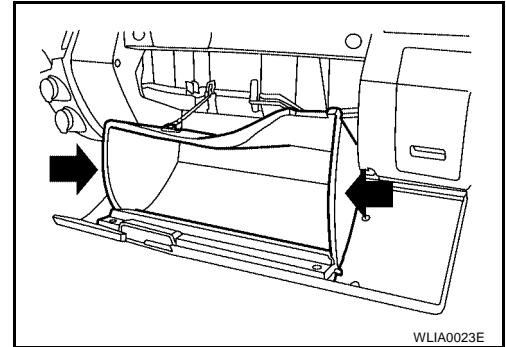

2. Remove the screw and remove the in-cabin microfilter cover.
3. Remove the in-cabin microfilters from the front heater and cooling unit housing.

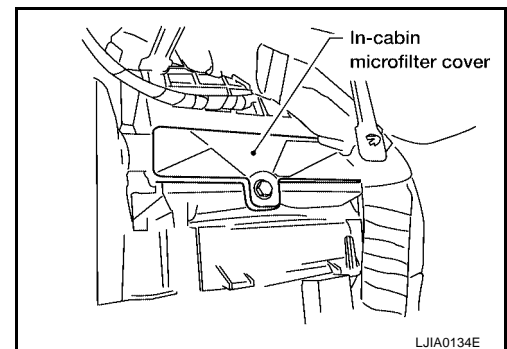

4. Insert the first new in-cabin microfilter into the front heater and cooling unit housing and slide it over to the right. Insert the second new in-cabin microfilter into the front heater and cooling unit housing.

#### NOTE:

The in-cabin microfilters are marked with air flow arrows. The end of the microfilter with the arrow should face the rear of the vehicle. The arrows should point downward.

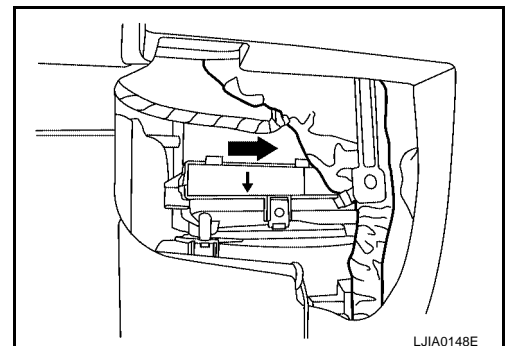

# IN-CABIN MICROFILTER

5. Install the in-cabin microfilter cover.

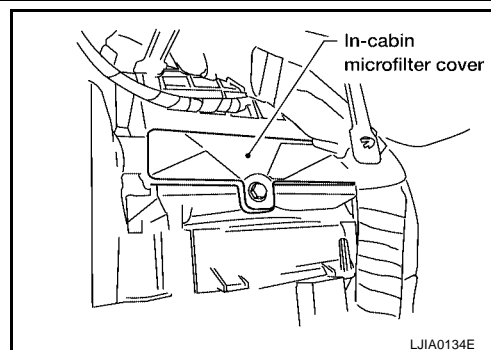

6. Close the lower glove box completely.

A

B

C

D

E

F

G

H

I

**ATC**

K

L

M

# HEATER & COOLING UNIT ASSEMBLY

## HEATER & COOLING UNIT ASSEMBLY

PF27110

### Components

EJS004PT

### Front Heater and Cooling Unit Assembly

SEC. 271 • 276 • 278

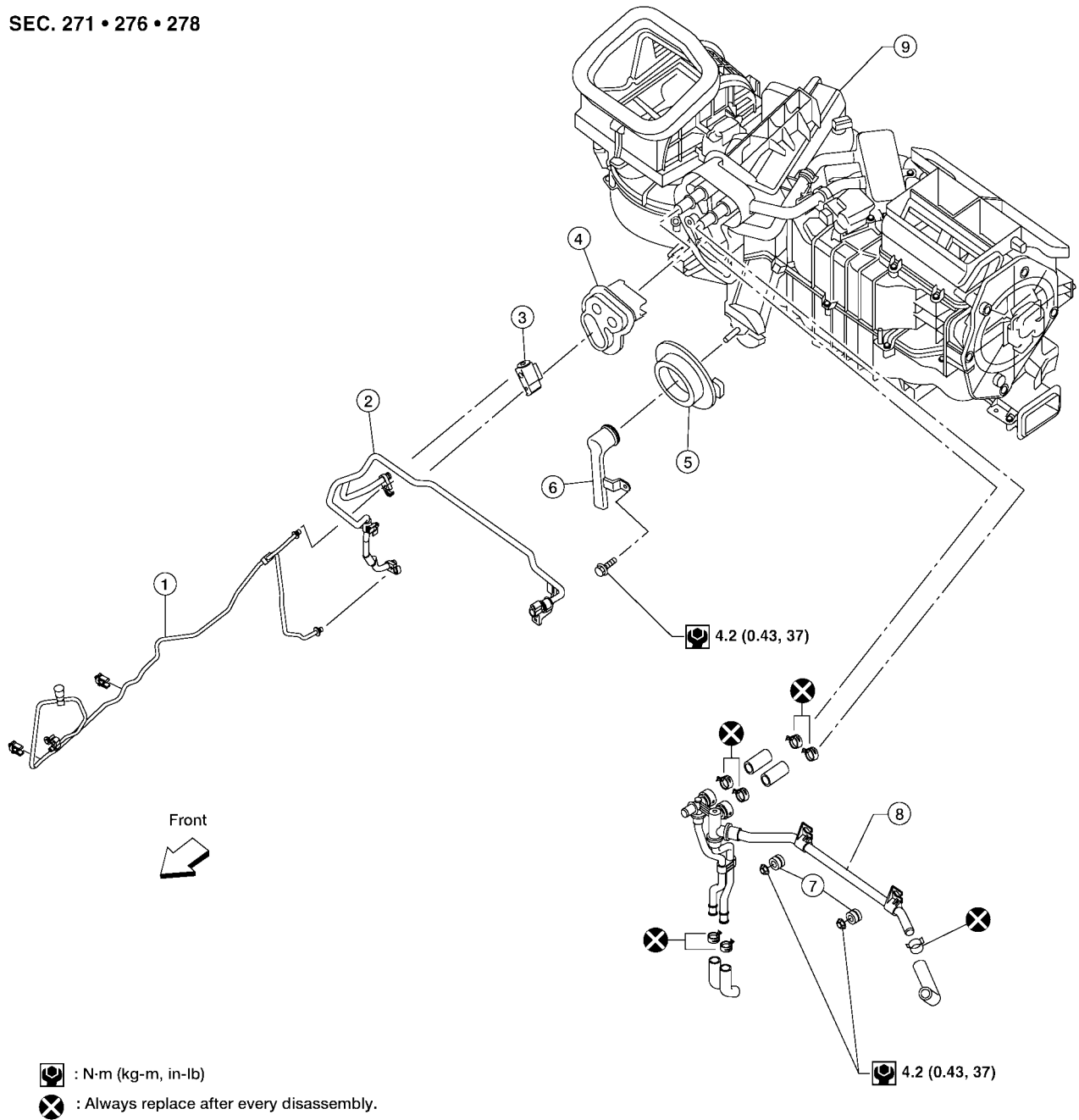

WJIA1402E

- |   |                                 |   |
|---|---------------------------------|---|
| 1. Front high-pressure A/C pipe                   | 2. Front low-pressure A/C pipe  | 3. Front expansion valve                  |
| 4. Front heater core and evaporator pipes grommet | 5. Front A/C drain hose grommet | 6. Front A/C drain hose                   |
| 7. Front heater core pipe mounts                  | 8. Front heater core pipes      | 9. Front heater and cooling unit assembly |



# HEATER & COOLING UNIT ASSEMBLY

## Rear Heater and Cooling Unit Assembly

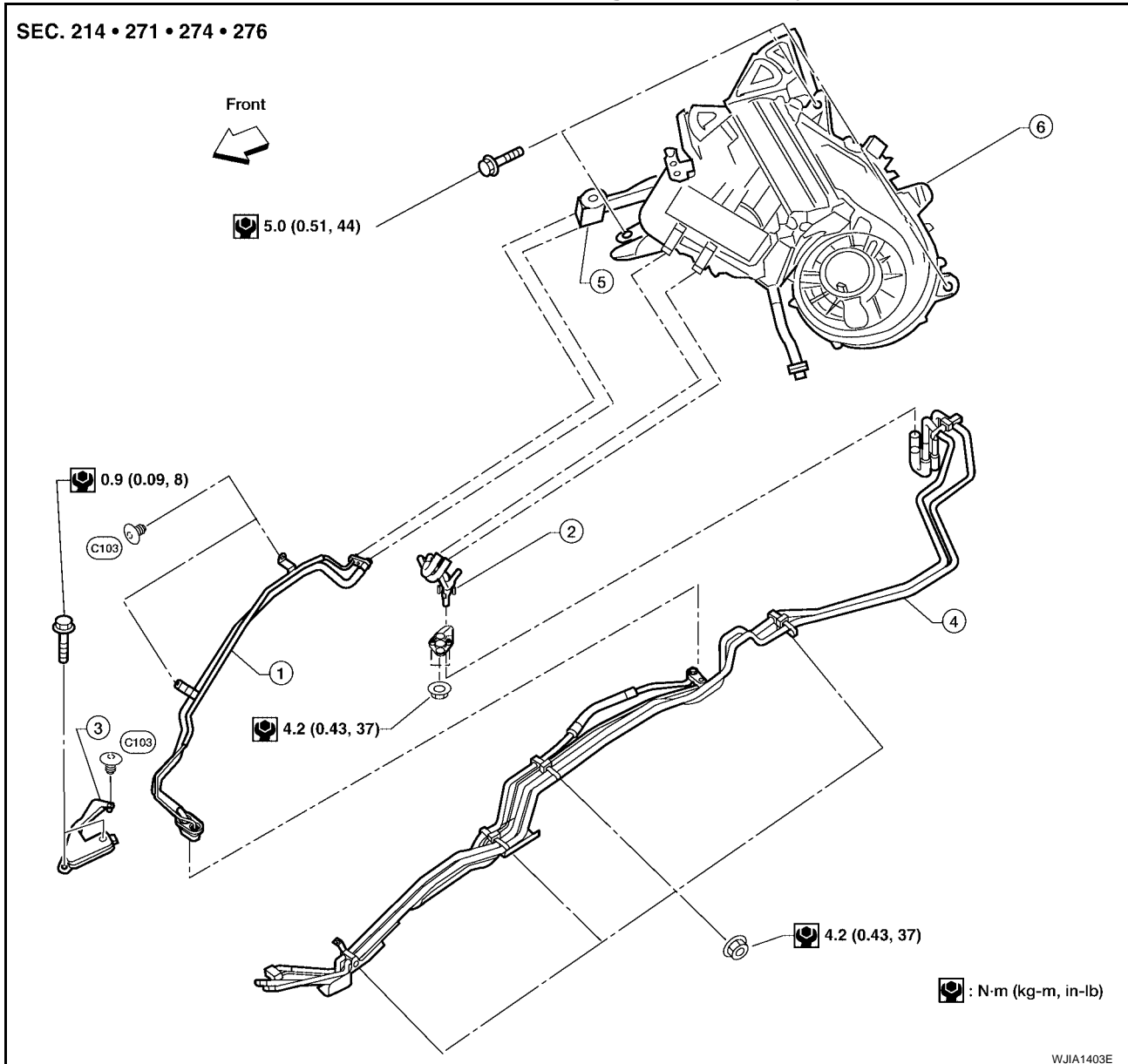

- |   |                           |  |
|---|---------------------------|--|
| 1. Rear high- and low-pressure A/C pipes                            | 2. Rear heater core hoses | 3. Rear high- and low-pressure A/C pipes cover |
| 4. Underfloor rear high- and low-pressure A/C and heater core pipes | 5. Rear expansion valve   | 6. Rear heater and cooling unit assembly       |

## Removal and Installation FRONT HEATER AND COOLING UNIT ASSEMBLY

EJS004PU

### Removal

1. Discharge the refrigerant from the A/C system. Refer to [ATC-154, "Discharging Refrigerant"](#).
2. Drain the coolant from the engine cooling system. Refer to [MA-13, "DRAINING ENGINE COOLANT"](#).

## HEATER & COOLING UNIT ASSEMBLY

3. Remove the front heater core pipes RH nut.
4. Disconnect the front heater core hoses from the front heater core.
5. Disconnect the high- and low-pressure A/C pipes from the front expansion valve.
6. Move the two front seats to the rearmost position on the seat track.
7. Remove the instrument panel and console panel. Refer to [IP-10, "Removal and Installation"](#) .
8. Remove the two front floor ducts.
9. Remove the steering column. Refer to [PS-10, "Removal and Installation"](#) .
10. Disconnect the instrument panel wire harness at the RH and LH in-line connector brackets, and the fuse block (SMJ) electrical connectors. Refer to [PG-43, "Harness Layout"](#) .
11. Remove the covers then remove the three steering member bolts from each side to disconnect the steering member from the vehicle body.
12. Remove the front heater and cooling unit assembly with it attached to the steering member, from the vehicle.

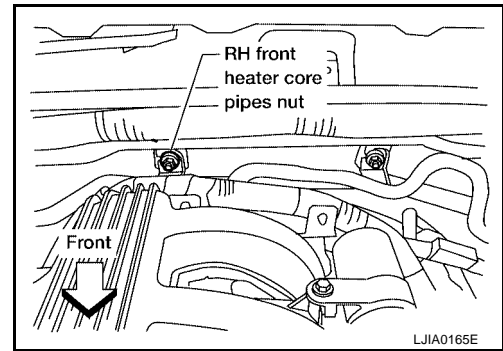

### CAUTION:

- Use care not to damage the seats and interior trim panels when removing the front heater and cooling unit assembly with it attached to the steering member.
  - Use suitable plugs on the heater core pipes to prevent coolant leakage.
13. Remove the front heater and cooling unit assembly from the steering member.

### Installation

Installation is in the reverse order of removal.

### CAUTION:

- Replace the O-ring of the low-pressure A/C pipe and high-pressure A/C pipe with a new one, and apply compressor oil to the O-ring for installation. Refer to [ATC-156, "Components"](#) .
- After charging the refrigerant, check for leaks. Refer to [ATC-170, "Checking for Refrigerant Leaks"](#) .

### NOTE:

- Fill the engine cooling system with the specified coolant mixture. Refer to [MA-14, "REFILLING ENGINE COOLANT"](#) .
- Recharge the A/C system. Refer to [ATC-154, "Evacuating System and Charging Refrigerant"](#) .

## REAR HEATER AND COOLING UNIT ASSEMBLY

### Removal

1. Discharge the refrigerant from the A/C system. Refer to [ATC-154, "Discharging Refrigerant"](#) .
2. Drain the coolant from the engine cooling system. Refer to [MA-13, "DRAINING ENGINE COOLANT"](#) .
3. Remove the luggage side lower finisher RH. Refer to [EI-27, "Components"](#) .
4. Disconnect the rear heater core hoses from the rear heater core.
5. Disconnect the rear A/C high- and low-pressure A/C pipes from the rear expansion valve.
6. Disconnect the following electrical connectors:
  - Rear blower motor
  - Rear blower motor resistor
  - Rear air mix door motor
7. Disconnect the ducts from the rear heater and cooling unit assembly.
8. Remove the three bolts to remove the rear heater and cooling unit assembly.

### Installation

Installation is in the reverse order of removal.

## HEATER & COOLING UNIT ASSEMBLY

---

### CAUTION:

- Replace the O-ring of the low-pressure A/C pipe and high-pressure A/C pipe with a new one, and apply compressor oil to the O-ring for installation. Refer to [ATC-156, "Components"](#) .
- After charging the refrigerant, check for leaks. Refer to [ATC-170, "Checking for Refrigerant Leaks"](#) .

### NOTE:

- Fill the engine cooling system with the specified coolant mixture. Refer to [MA-14, "REFILLING ENGINE COOLANT"](#) .
- Recharge the A/C system. Refer to [ATC-154, "Evacuating System and Charging Refrigerant"](#) .

A

B

C

D

E

F

G

H

I

ATC

K

L

M

# HEATER CORE

## HEATER CORE

PF27140

### Components

EJS004PV

#### Front Heater and Cooling Unit Assembly

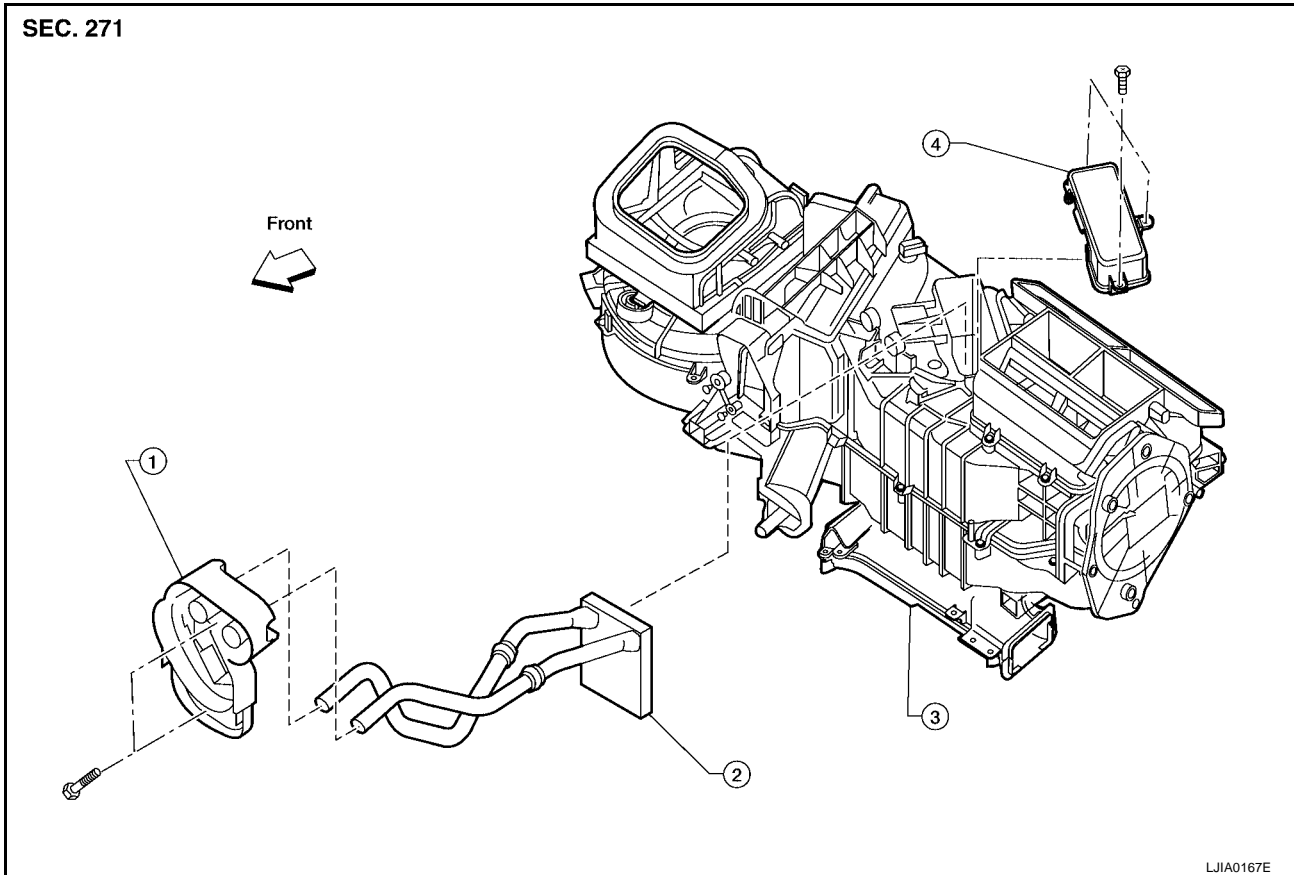

1. Front heater core and evaporator pipe
2. Front heater core bracket
3. Front heater and cooling unit assembly
4. Front heater core cover

#### Rear Heater and Cooling Unit Assembly

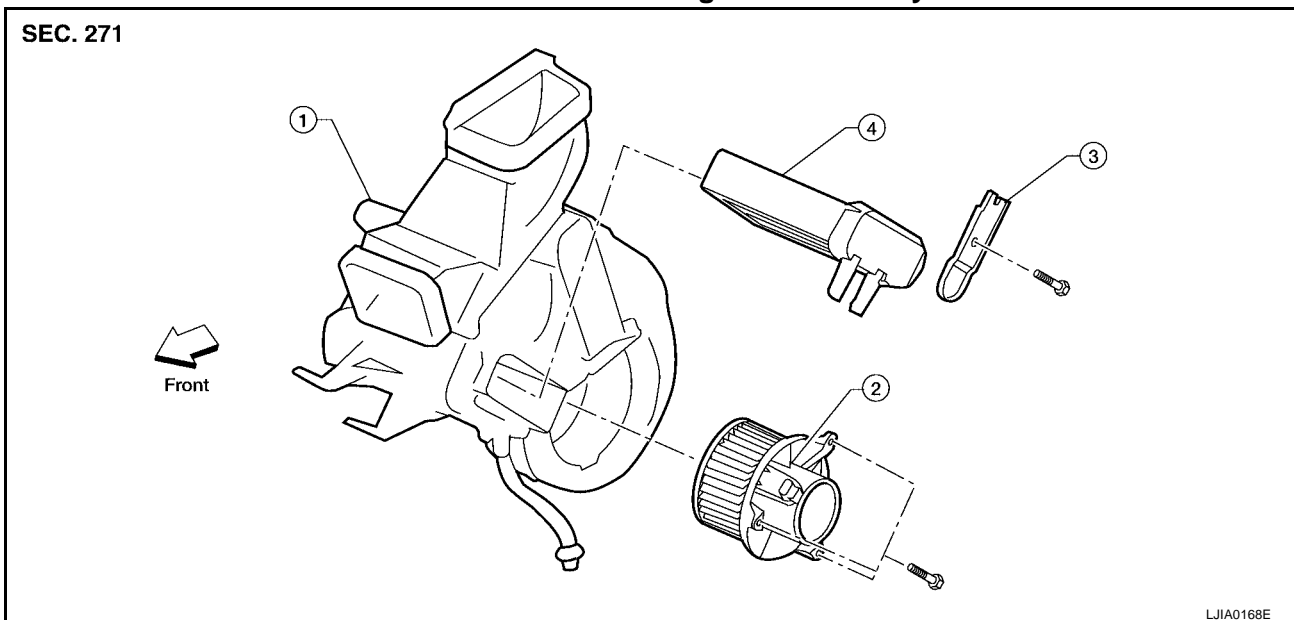

1. Rear heater and cooling unit assembly
2. Rear blower motor
3. Rear heater core bracket
4. Rear heater core

# HEATER CORE

EJS004PW

## Removal and Installation

### FRONT HEATER CORE

#### Removal

1. Remove the front heater and cooling unit assembly. Refer to [ATC-137, "FRONT HEATER AND COOLING UNIT ASSEMBLY"](#).
2. Remove the three screws and remove the front heater core cover.
3. Remove the front heater core and evaporator pipe bracket.
4. Remove the front heater core.

#### NOTE:

If the in-cabin microfilters are contaminated from coolant leaking from the front heater core, replace the in-cabin microfilters with new ones before installing the new front heater core.

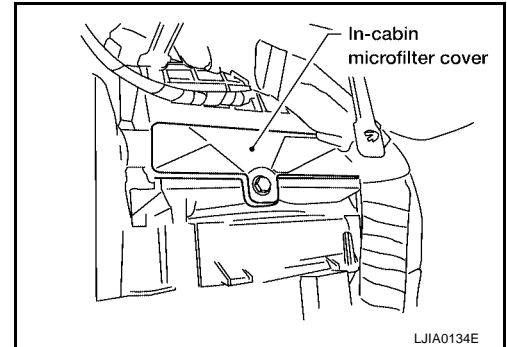

#### Installation

Installation is in the reverse order of removal.

### REAR HEATER CORE

#### Removal

1. Partially drain the engine cooling system. Refer to [MA-13, "DRAINING ENGINE COOLANT"](#).
2. Remove the rear heater and cooling unit assembly. Refer to [ATC-138, "REAR HEATER AND COOLING UNIT ASSEMBLY"](#).
3. Remove the rear heater core bracket.
4. Remove the heater core.

#### Installation

Installation is in the reverse order of removal.

A  
B  
C  
D  
E  
F  
G  
H  
I  
K  
L  
M

ATC

# HEATER PUMP

PF9:92264

EJS004PX

## HEATER PUMP

### Removal and Installation

#### Heater Pump

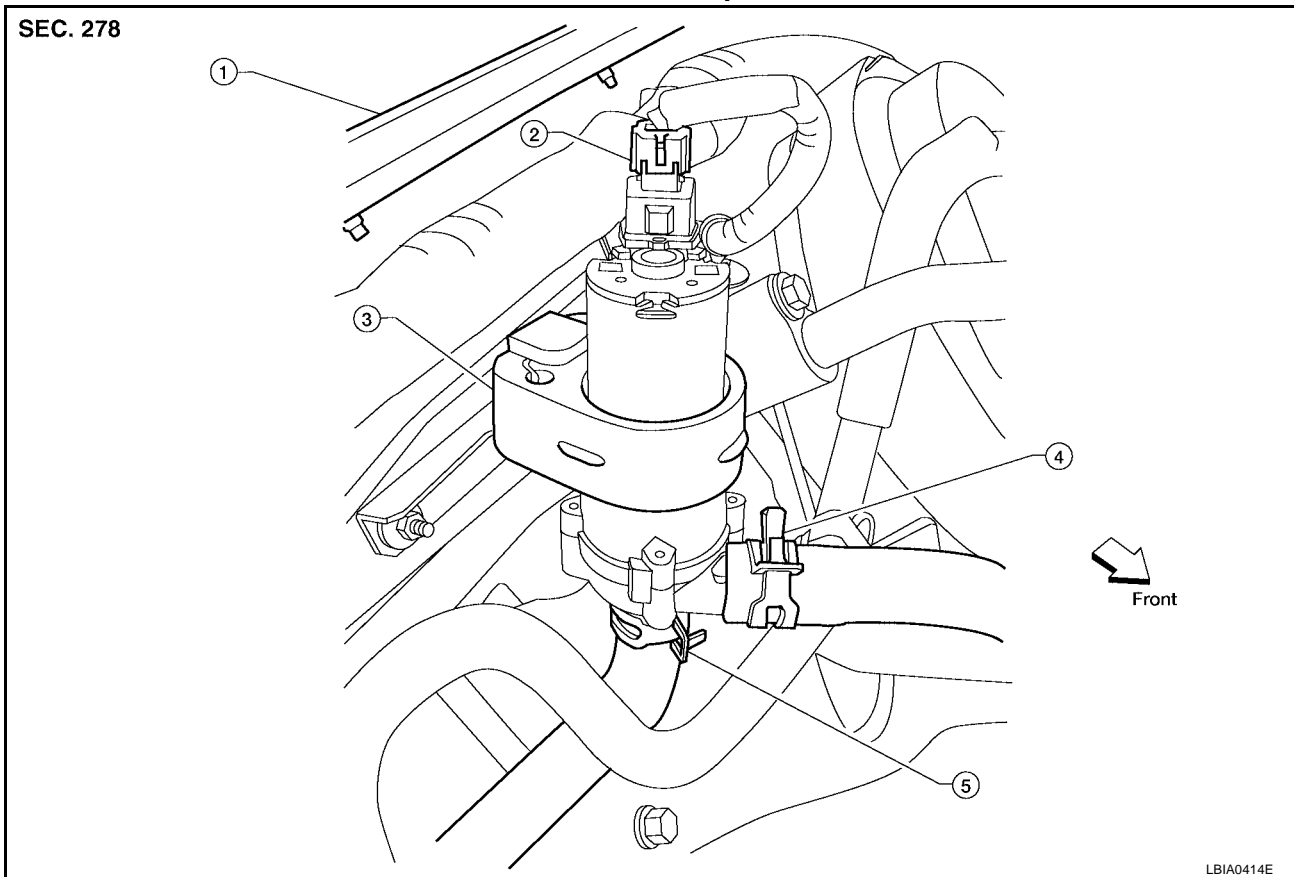

1. Cowl top
2. Heater pump electrical connector
3. Heater pump
4. Heater hose and clamp
5. Heater hose and clamp

#### REMOVAL

1. Partially drain the engine cooling system. Refer to [MA-13, "DRAINING ENGINE COOLANT"](#) .
2. Disconnect the heater pump electrical connector.
3. Disconnect the two heater hoses.
4. Remove the heater pump from the bracket securing the heater pump to the cowl top.

#### **CAUTION:**

**Do not disassemble the heater pump, replace the heater pump as an assembly.**

#### INSTALLATION

Installation is in the reverse order of removal.

#### **CAUTION:**

- The heater pump rubber mount must be fully seated on the bracket.
- Do not disassemble the heater pump, replace the heater pump as an assembly.

# INTAKE DOOR MOTOR

PF2:27730

EJS004PY

## INTAKE DOOR MOTOR Removal and Installation

### Intake Door Motor - Front Heater and Cooling Unit Assembly

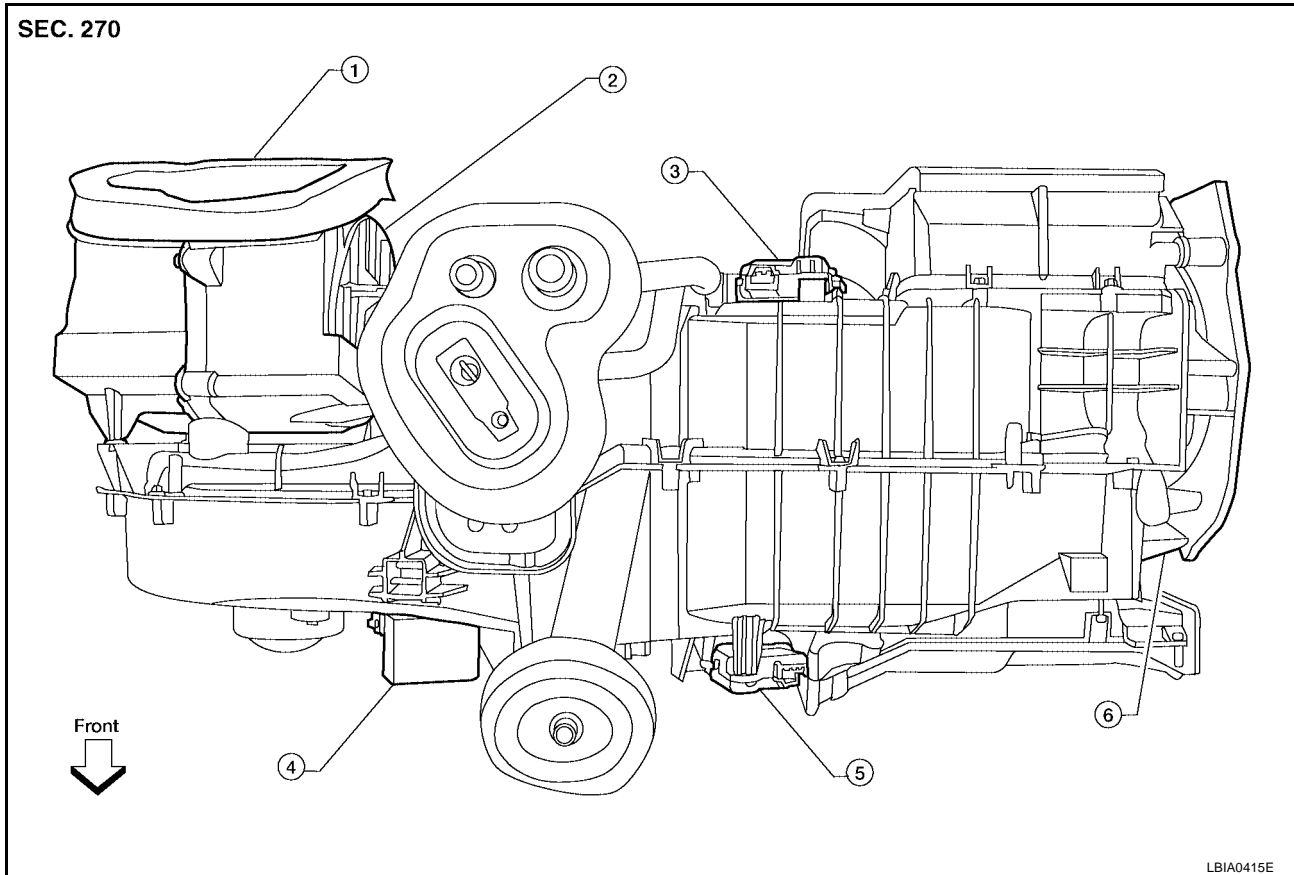

- |   |                                |                                   |
|---|--------------------------------|-----------------------------------|
| 1. Front heater and cooling unit assembly | 2. Intake door motor           | 3. Air mix door motor (passenger) |
| 4. Variable blower control                | 5. Air mix door motor (driver) | 6. Mode door motor                |

#### REMOVAL

1. Remove the front heater and cooling unit assembly. Refer to [ATC-137, "FRONT HEATER AND COOLING UNIT ASSEMBLY"](#).
2. Remove the steering member from the front heater and cooling unit assembly.
3. Disconnect the intake door motor electrical connector.
4. Remove the three screws and remove the intake door motor.

#### INSTALLATION

Installation is in the reverse order of removal.

# MODE DOOR MOTOR

## MODE DOOR MOTOR

PFP:27731

### Removal and Installation

EJS004PZ

#### Mode Door Motor - Front Heater and Cooling Unit Assembly

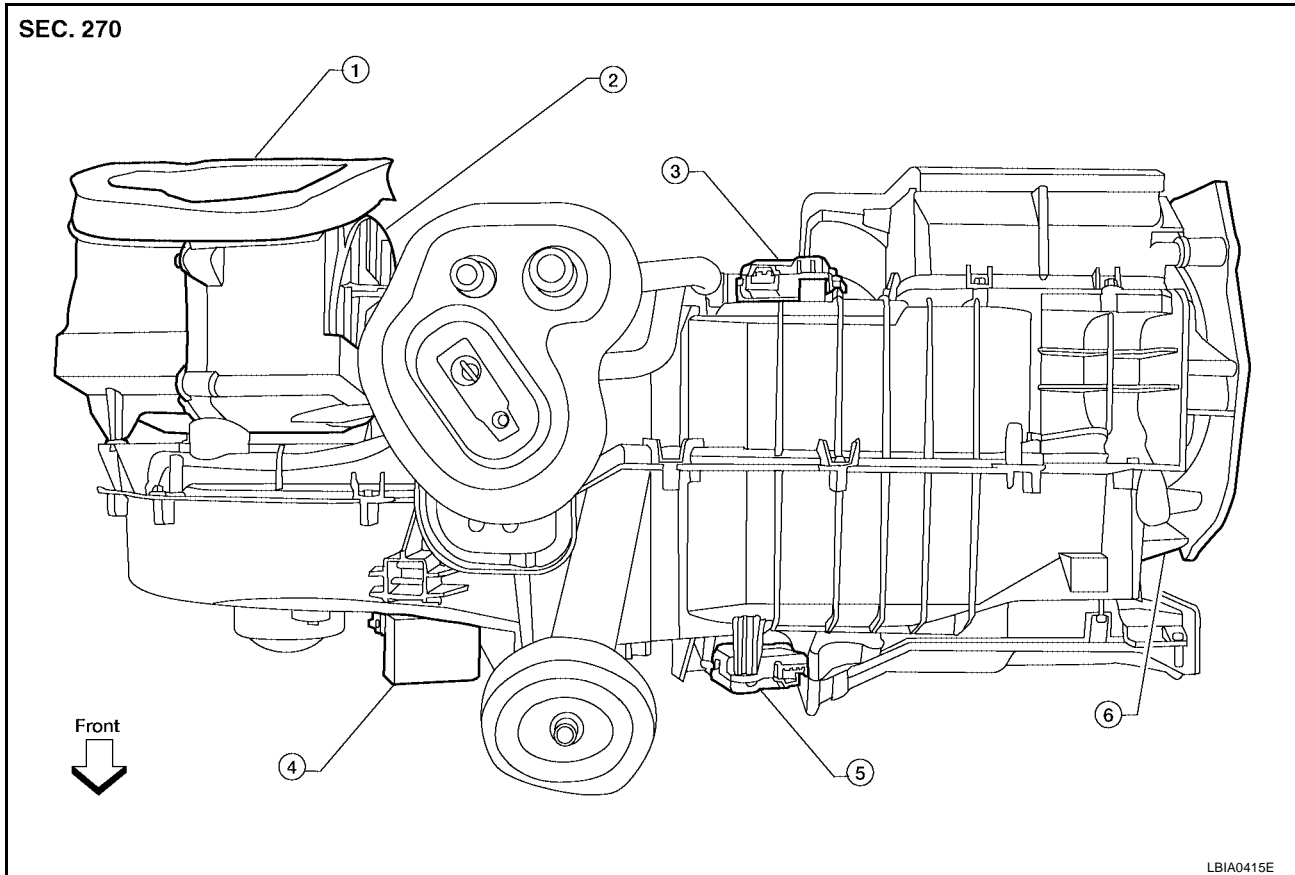

- |   |                                |                                   |
|---|--------------------------------|-----------------------------------|
| 1. Front heater and cooling unit assembly | 2. Intake door motor           | 3. Air mix door motor (passenger) |
| 4. Variable blower control                | 5. Air mix door motor (driver) | 6. Mode door motor                |

### REMOVAL

1. Remove the instrument panel side finisher. Refer to [EI-28, "LOWER DASH SIDE FINISHER"](#) .
2. Remove the lower instrument cover. Refer to [IP-15, "LOWER INSTRUMENT PANEL RH AND LOWER GLOVE BOX"](#) .
3. Disconnect the mode door motor electrical connector.
4. Remove the three screws and remove the mode door motor.

### INSTALLATION

Installation is in the reverse order of removal.



# AIR MIX DOOR MOTOR

PF2:27732

EJS004Q0

## AIR MIX DOOR MOTOR

### Components

#### Air Mix Door Motors - Front Heater and Cooling Unit Assembly

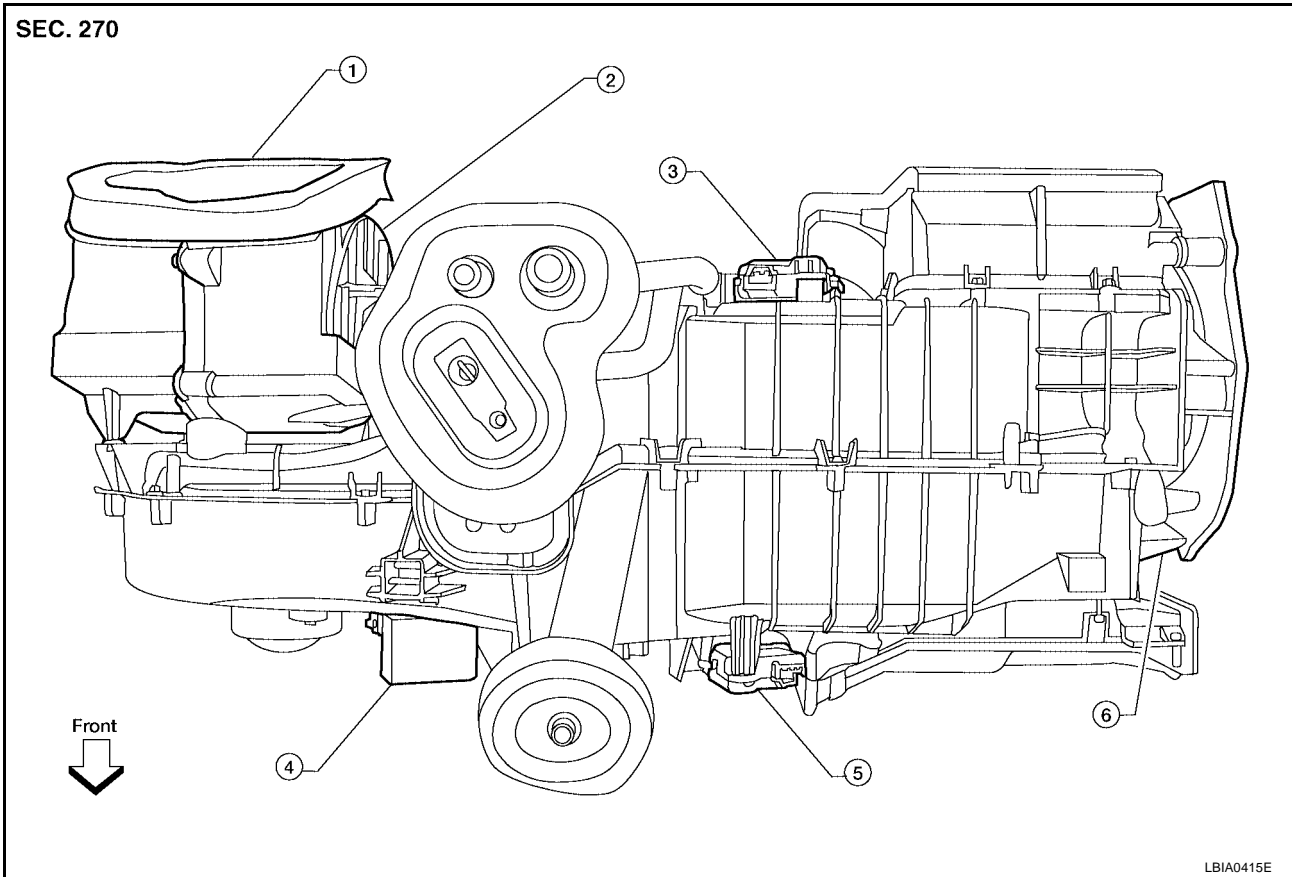

- |   |                                |                                   |
|---|--------------------------------|-----------------------------------|
| 1. Front heater and cooling unit assembly | 2. Intake door motor           | 3. Air mix door motor (passenger) |
| 4. Variable blower control                | 5. Air mix door motor (driver) | 6. Mode door motor                |

### Removal and Installation FRONT AIR MIX DOOR MOTOR (DRIVER)

EJS004Q1

#### Removal

1. Remove the instrument panel side finisher. Refer to [EI-27, "Components"](#).
2. Remove the lower instrument panel RH. Refer to [IP-15, "LOWER INSTRUMENT PANEL RH AND LOWER GLOVE BOX"](#).
3. Disconnect the air mix door motor electrical connector.
4. Remove the three screws and remove the air mix door motor.

#### Installation

Installation is in the reverse order of removal.

### FRONT AIR MIX DOOR MOTOR (PASSENGER)

#### Removal

1. Remove the front heater and cooling unit assembly. Refer to [ATC-137, "FRONT HEATER AND COOLING UNIT ASSEMBLY"](#).
2. Remove the steering member from the front heater and cooling unit assembly.
3. Disconnect the air mix door motor electrical connector.
4. Remove the three screws and remove the air mix door motor.

#### Installation

Installation is in the reverse order of removal.

# AIR MIX DOOR MOTOR

## REAR AIR MIX DOOR MOTOR

### Removal

1. Remove the luggage side lower finisher RH. Refer to [EI-27, "Components"](#) .
2. Disconnect the rear air mix door motor electrical connector.
3. Remove the three screws and remove the rear air mix door motor.

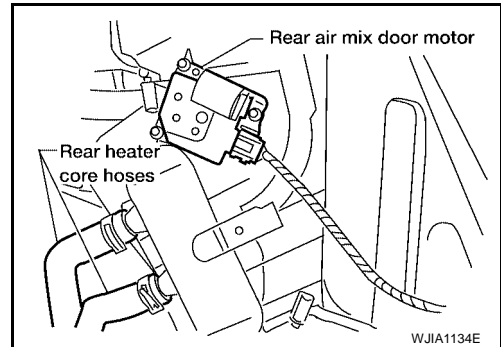

### Installation

Installation is in the reverse order of removal.

# VARIABLE BLOWER CONTROL

## VARIABLE BLOWER CONTROL

PF2:27200

### Removal and Installation

EJS004Q2

#### Variable Blower Control - Front Heater and Cooling Unit Assembly

SEC. 270

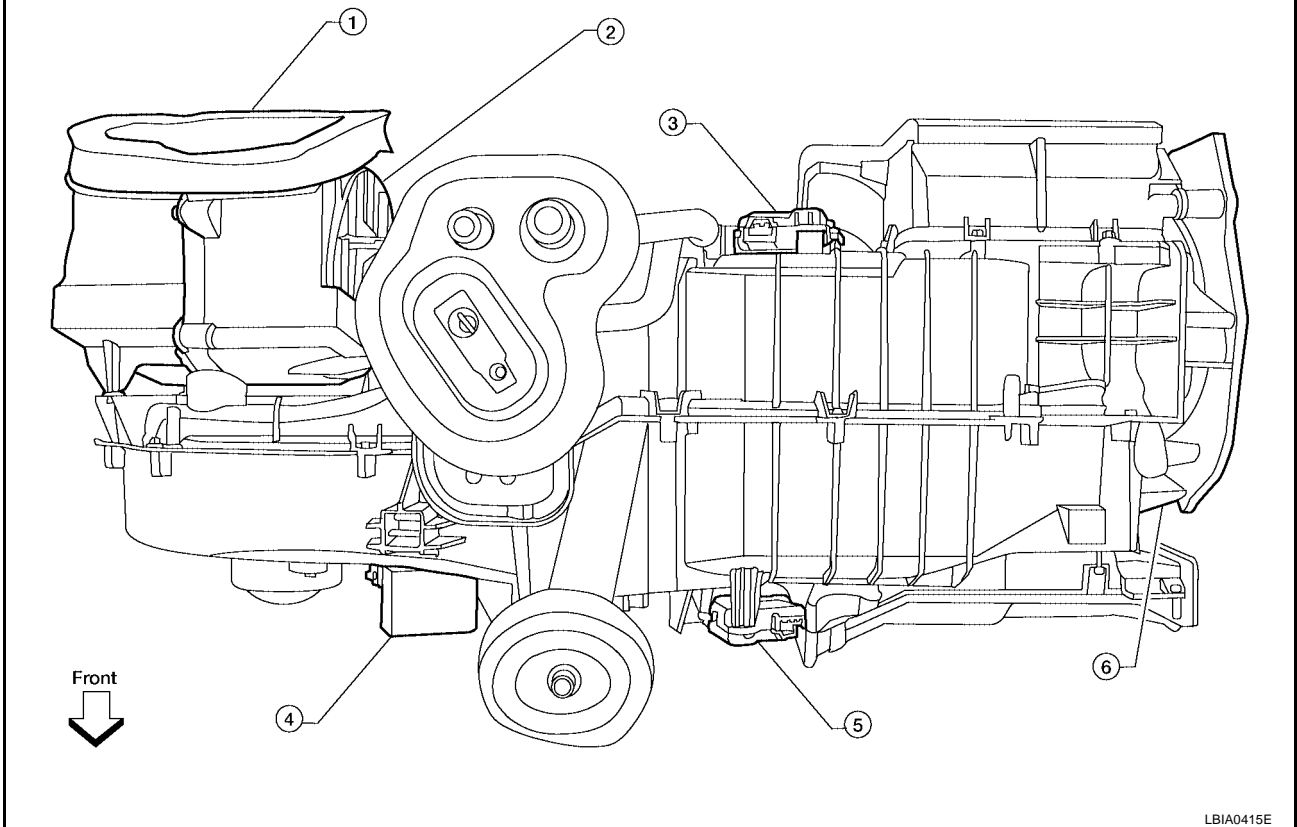

- |   |                                |                                   |
|---|--------------------------------|-----------------------------------|
| 1. Front heater and cooling unit assembly | 2. Intake door motor           | 3. Air mix door motor (passenger) |
| 4. Variable blower control                | 5. Air mix door motor (driver) | 6. Mode door motor                |

#### REMOVAL

1. Disconnect the variable blower control electrical connector.
2. Remove the two screws and remove the variable blower control.

#### INSTALLATION

Installation is in the reverse order of removal.

A

B

C

D

E

F

G

H

I

ATC

K

L

M

# REAR BLOWER MOTOR RESISTOR

## REAR BLOWER MOTOR RESISTOR

PF27150

### Removal and Installation

EJS00403

#### Rear Blower Motor Resistor

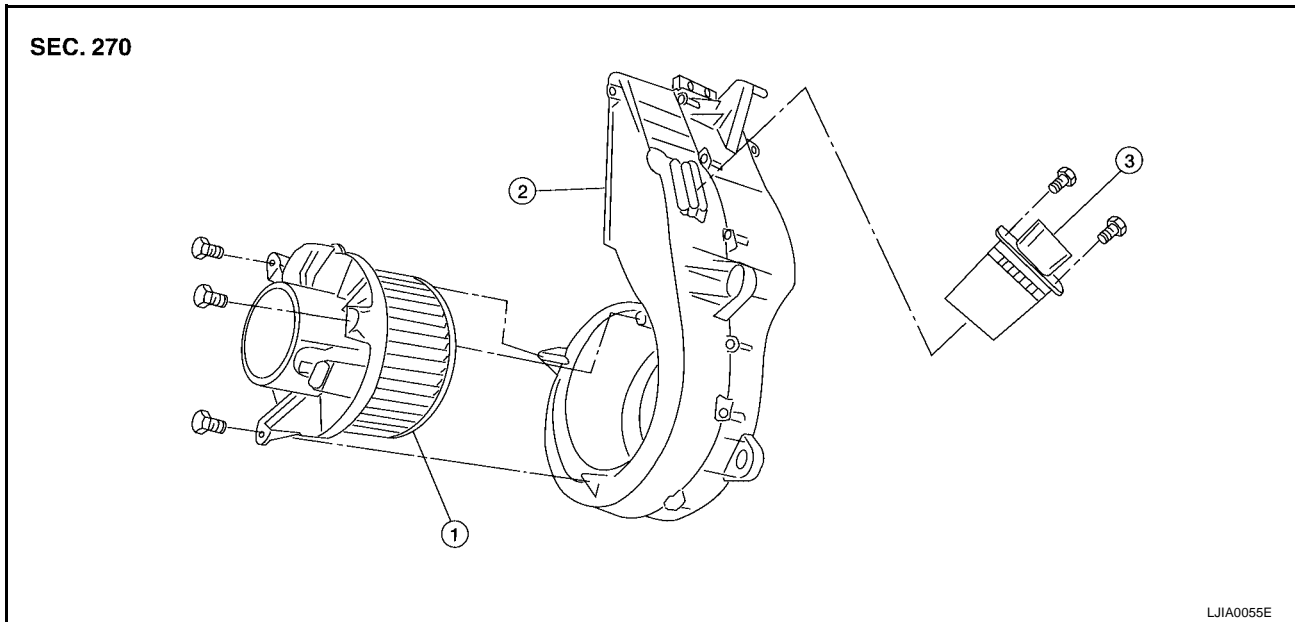

1. Rear blower motor

2. Rear blower motor case

3. Rear blower motor resistor

#### REMOVAL

1. Remove the luggage side lower finisher RH. Refer to [EI-27, "Components"](#).
2. Disconnect the rear blower motor resistor electrical connector.
3. Remove the two screws and remove the rear blower motor resistor.

#### INSTALLATION

Installation is in the reverse order of removal.

# DUCTS AND GRILLES

## DUCTS AND GRILLES

PFP:27860

### Components

EJS004Q4

#### Ducts - Front Heater and Cooling Unit Assembly

SEC. 270 • 271

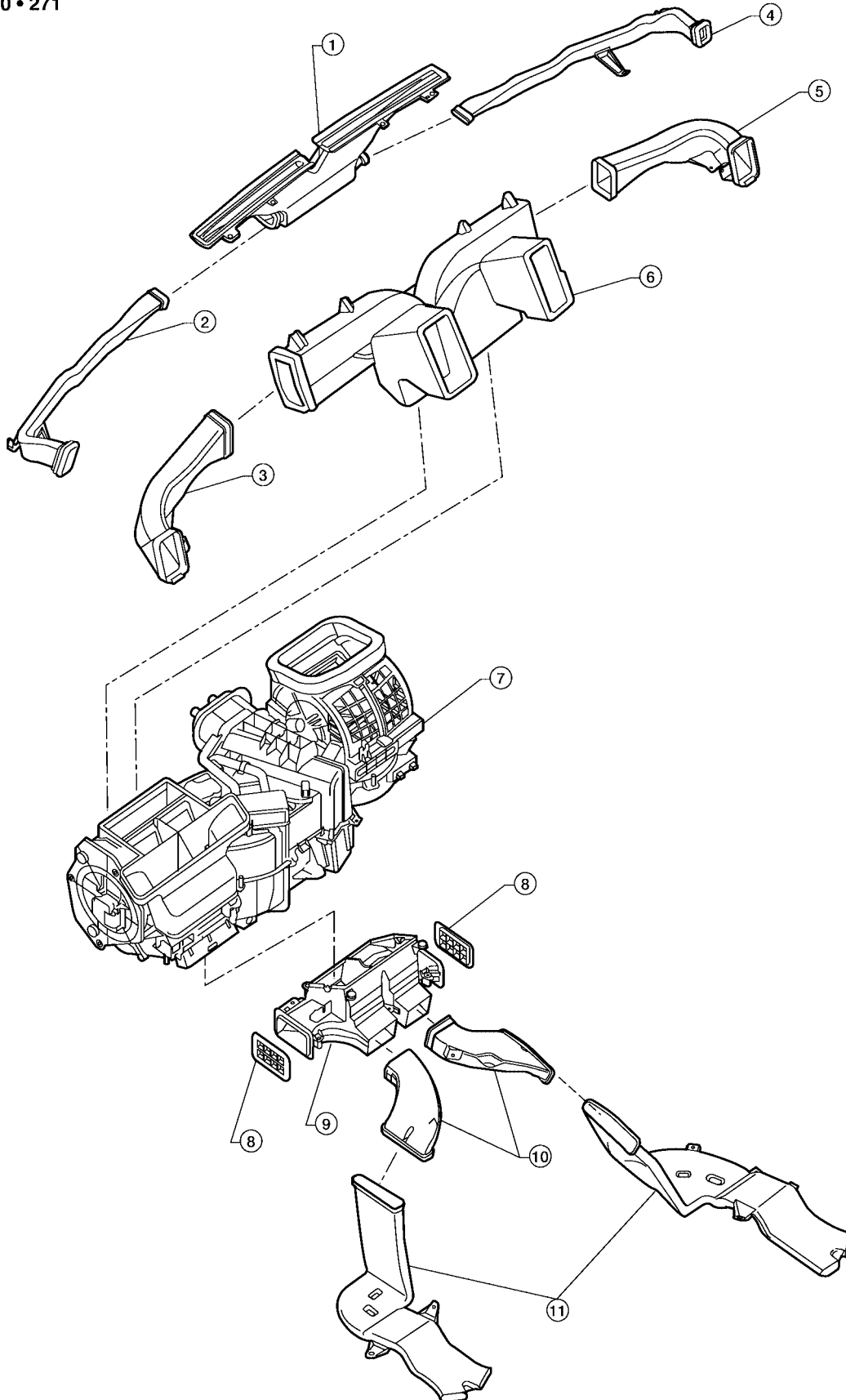

A  
B  
C  
D  
E  
F  
G  
H  
I  
ATC  
K  
L  
M

# DUCTS AND GRILLES

- |   |                                 |                           |
|---|---------------------------------|---------------------------|
| 1. Defroster nozzle                       | 2. LH side demister duct        | 3. LH ventilator duct     |
| 4. RH side demister duct                  | 5. RH ventilator duct           | 6. Center ventilator duct |
| 7. Front heater and cooling unit assembly | 8. Floor connector duct grilles | 9. Floor connector duct   |
| 10. Front floor ducts                     | 11. Rear floor ducts            |                           |

## Ducts - Rear Heater and Cooling Unit Assembly

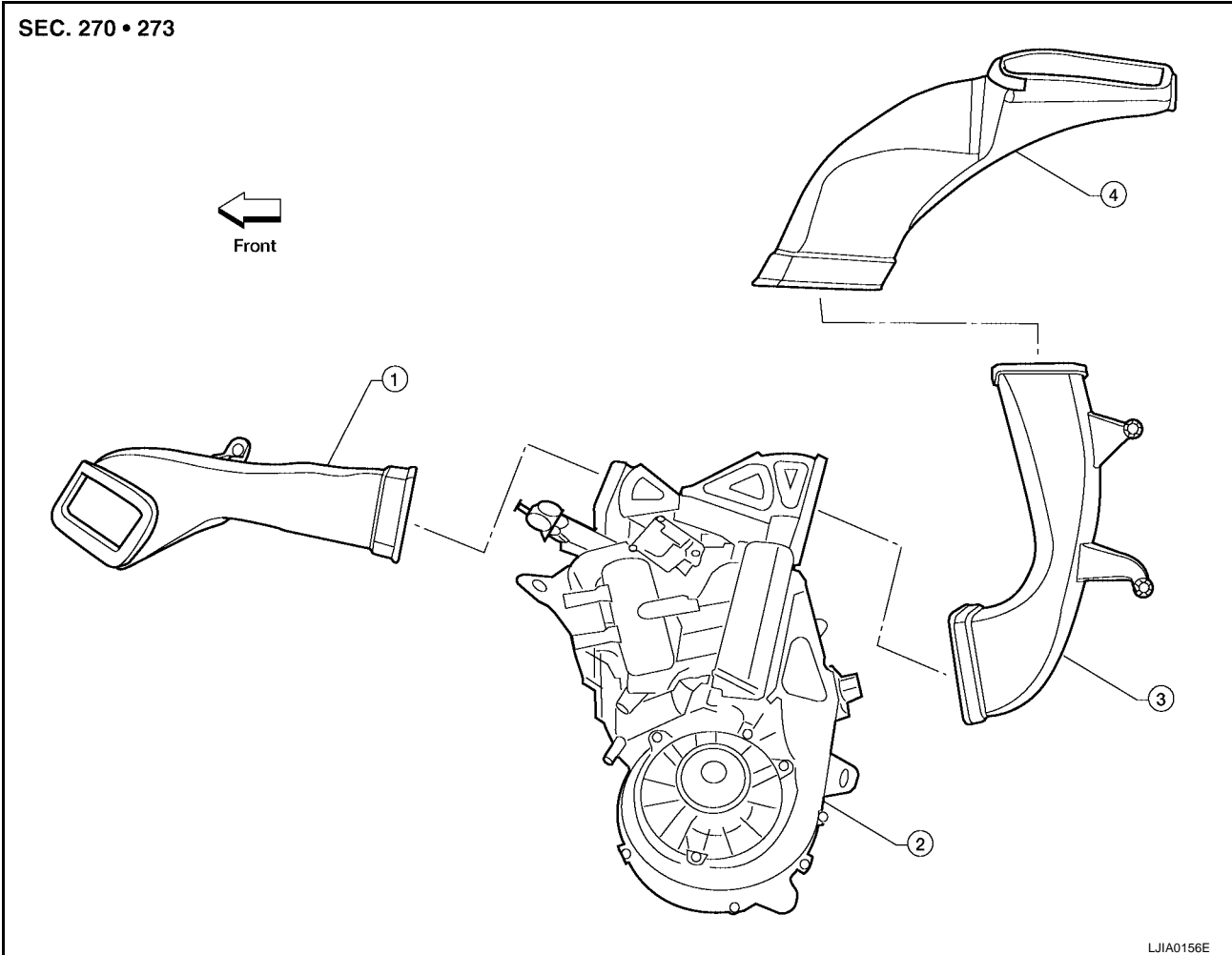

- |                             |  |                             |
|-----------------------------|--|-----------------------------|
| 1. Side rear floor duct     | 2. Rear heater and cooling unit assembly | 3. Rear lower overhead duct |
| 4. Rear upper overhead duct |  |                             |

# DUCTS AND GRILLES

## Grilles

SEC. 280 • 685 • 738

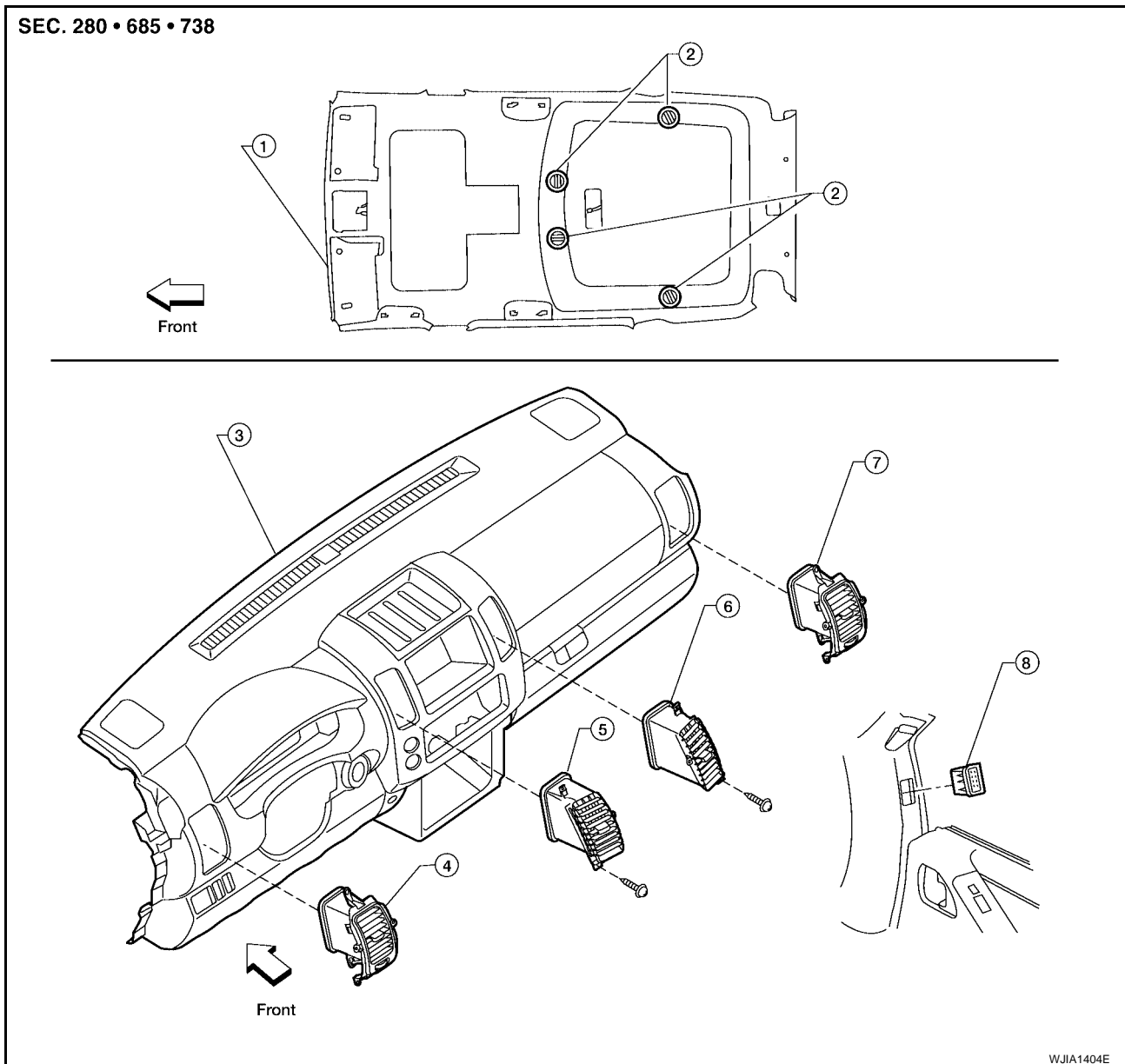

- |                              |                            |                                      |
|------------------------------|----------------------------|--------------------------------------|
| 1. Headliner                 | 2. Overhead grilles        | 3. Instrument panel and pad assembly |
| 4. LH side ventilator grille | 5. LH ventilator grille    | 6. RH ventilator grille              |
| 7. RH side ventilator grille | 8. RH side demister grille |                                      |

### Removal and Installation DEFROSTER NOZZLE

EJS004Q5

#### Removal

1. Remove the front heater and cooling unit assembly. Refer to [ATC-137, "FRONT HEATER AND COOLING UNIT ASSEMBLY"](#).
2. Remove the defroster nozzle.

#### Installation

Installation is in the reverse order of removal.

### RH AND LH SIDE DEMISTER DUCT

#### Removal

1. Remove the front heater and cooling unit assembly. Refer to [ATC-137, "FRONT HEATER AND COOLING UNIT ASSEMBLY"](#).
2. Remove the center console. Refer to [IP-18, "Center Console"](#).

A  
B  
C  
D  
E  
F  
G  
H  
I  
ATC  
K  
L  
M

# DUCTS AND GRILLES

---

3. Remove the RH or LH side demister duct.

## Installation

Installation is in the reverse order of removal.

## RH AND LH VENTILATOR DUCT

### Removal

1. Remove the front heater and cooling unit assembly. Refer to [ATC-137, "FRONT HEATER AND COOLING UNIT ASSEMBLY"](#) .
2. Remove the center console. Refer to [IP-18, "Center Console"](#) .
3. Remove the RH or LH ventilator duct.

### Installation

Installation is in the reverse order of removal.

## CENTER VENTILATOR DUCT

### Removal

1. Remove the front heater and cooling unit assembly. Refer to [ATC-137, "FRONT HEATER AND COOLING UNIT ASSEMBLY"](#) .
2. Remove the center console. Refer to [IP-18, "Center Console"](#) .
3. Remove the defroster nozzle.
4. Remove the RH and LH ventilator ducts.
5. Remove the RH and LH side demister ducts.
6. Remove the center ventilator duct.

### Installation

Installation is in the reverse order of removal.

## FLOOR CONNECTOR DUCT

### Removal

1. Remove the front heater and cooling unit assembly. Refer to [ATC-137, "FRONT HEATER AND COOLING UNIT ASSEMBLY"](#) .
2. Remove the center console. Refer to [IP-18, "Center Console"](#) .
3. Remove the floor connector duct.

### Installation

Installation is in the reverse order of removal.

## FRONT AND REAR FLOOR DUCTS

### Removal

1. Remove the center console. Refer to [IP-18, "Center Console"](#) .
2. Remove the floor carpet. Refer to [EI-29, "Removal and Installation"](#) .
3. Remove the clips and remove the front and rear floor ducts.

### Installation

Installation is in the reverse order of removal.

## REAR OVERHEAD DUCTS

### Removal

1. Remove the luggage side lower finisher RH. Refer to [EI-27, "Components"](#) .
2. Remove the headliner. Refer to [EI-30, "HEADLINING"](#) .

#### NOTE:

The rear headliner duct (connected to the rear upper overhead duct) is part of the headliner and is replaced as an assembly.

3. Remove the clips and remove the rear upper and lower overhead ducts.

### Installation

Installation is in the reverse order of removal.



# DUCTS AND GRILLES

---

## SIDE REAR FLOOR DUCT

### Removal

1. Remove the luggage side lower finisher RH. Refer to [EI-27, "Components"](#) .
2. Reposition the floor carpet out of the way.
3. Remove the clips and remove the side rear floor duct.

### Installation

Installation is in the reverse order of removal.

## GRILLES

### Removal

1. Remove the necessary interior trim panel(s) to access the grille. Refer to [IP-10, "Removal and Installation"](#) .

#### NOTE:

The overhead grilles are part of the headliner. To replace the overhead grilles the headliner must be replaced. Refer to [EI-30, "HEADLINING"](#) .

2. Remove the grille from the interior trim panel.

### Installation

Installation is in the reverse order of removal.

A

B

C

D

E

F

G

H

I

ATC

K

L

M

# REFRIGERANT LINES

PF9:92600

EJS00406

## REFRIGERANT LINES

### HFC-134a (R-134a) Service Procedure SETTING OF SERVICE TOOLS AND EQUIPMENT Discharging Refrigerant

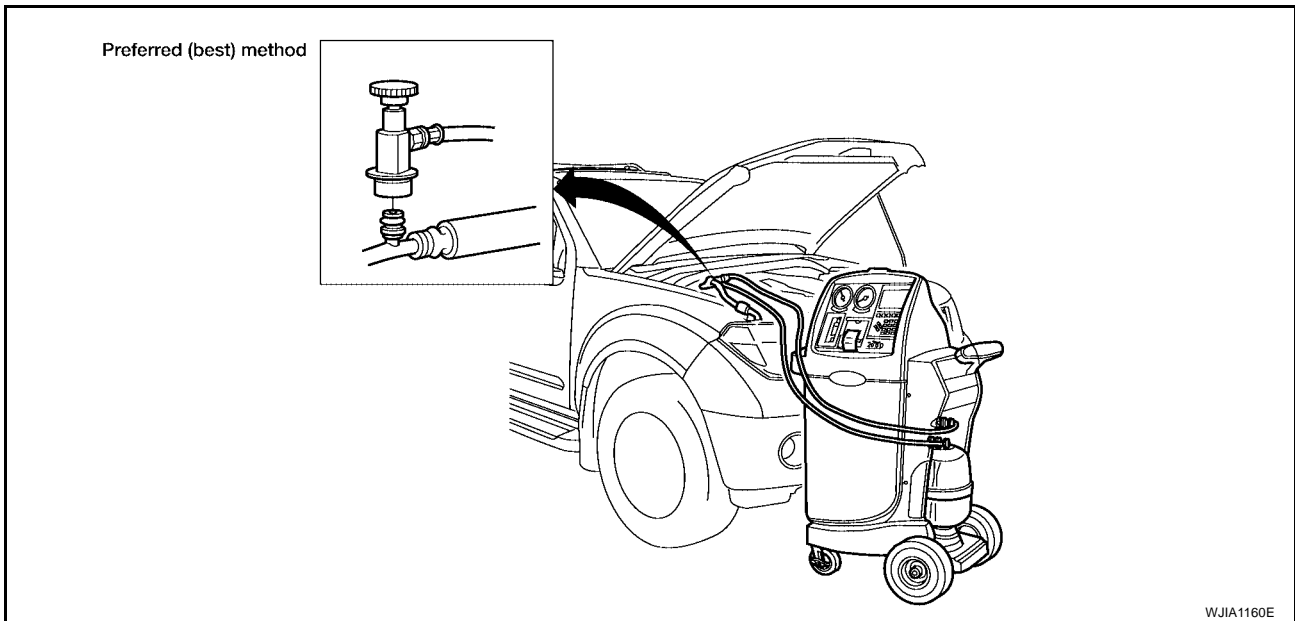

1. Shut-off valve
2. A/C service valve
3. Recovery/recycling equipment

#### **WARNING:**

Avoid breathing A/C refrigerant and oil vapor or mist. Exposure may irritate eyes, nose and throat. Remove HFC-134a (R-134a) refrigerant from the A/C system using certified service equipment meeting requirements of SAE J2210 HFC-134a (R-134a) recycling equipment or SAE J2201 HFC-134a (R-134a) recovery equipment. If an accidental system discharge occurs, ventilate the work area before resuming service. Additional health and safety information may be obtained from the refrigerant and oil manufacturers.

### Evacuating System and Charging Refrigerant

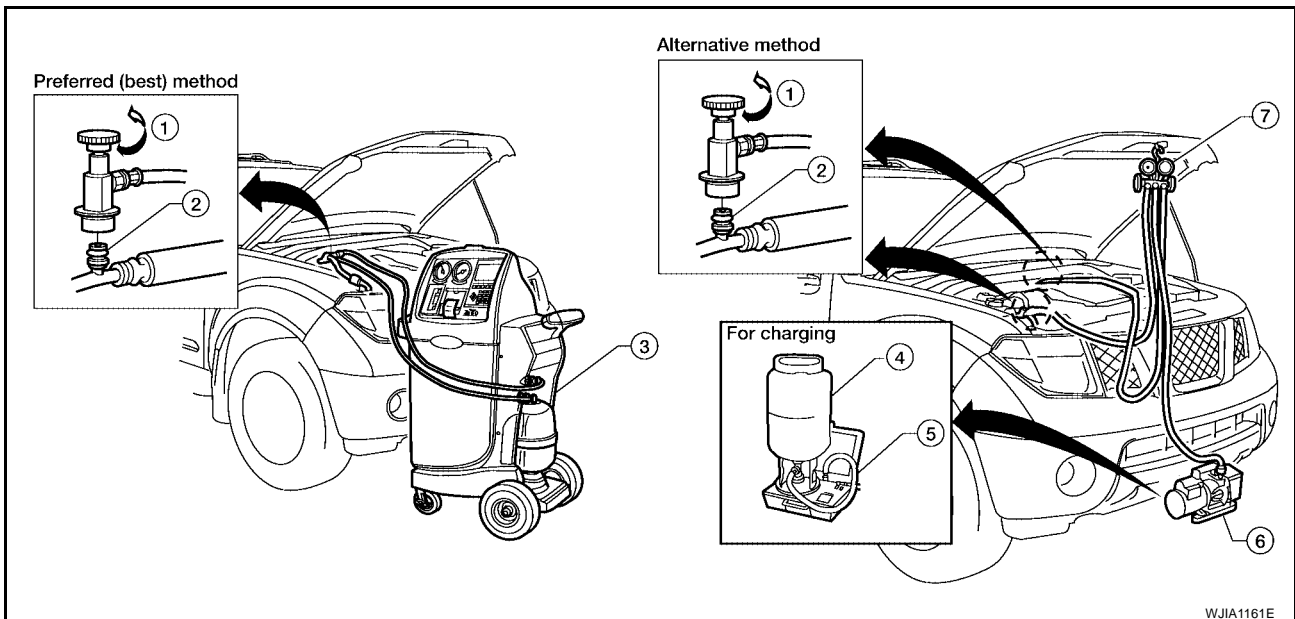

1. Shut-off valve
2. A/C service valve
3. Recovery/recycling equipment
4. Refrigerant container (HFC-134a)
5. Refrigerant weight scale (J-39699)
6. Vacuum pump (J-39649)
7. Manifold gauge set with hoses and couplers (J-39183-C)

# REFRIGERANT LINES

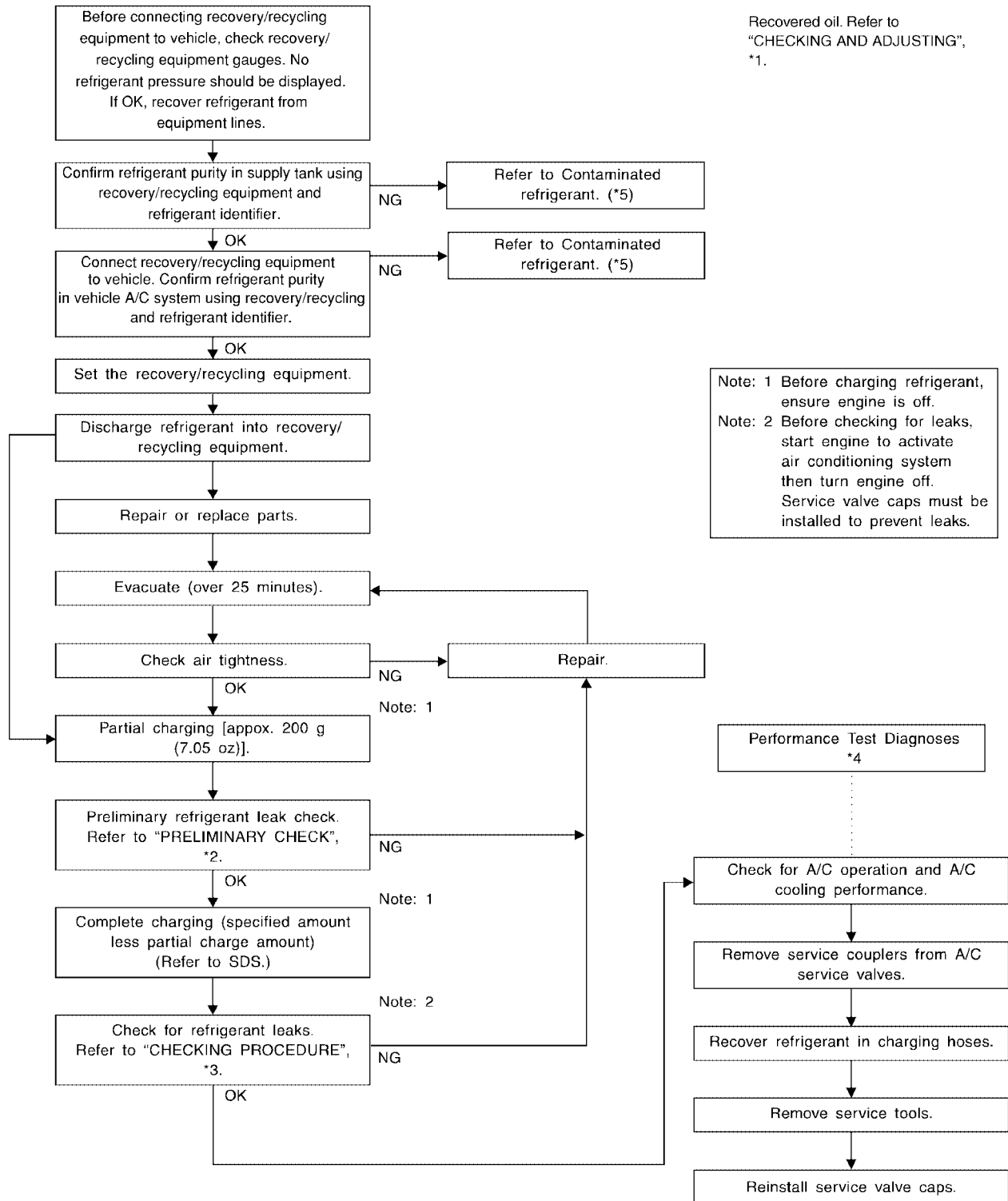

\*1 [ATC-22, "CHECKING AND ADJUSTING"](#).

\*2 [ATC-170, "Checking for Refrigerant Leaks"](#).

\*3 [ATC-170, "Checking for Refrigerant Leaks"](#).

\*4 [ATC-103, "PERFORMANCE TEST DIAGNOSES"](#).

\*5 [ATC-5, "Contaminated Refrigerant"](#).

WJIA1923E

# REFRIGERANT LINES

## Components

EJS004Q7

### Front A/C Compressor and Condenser

SEC. 270 • 271 • 274 • 276 • 278

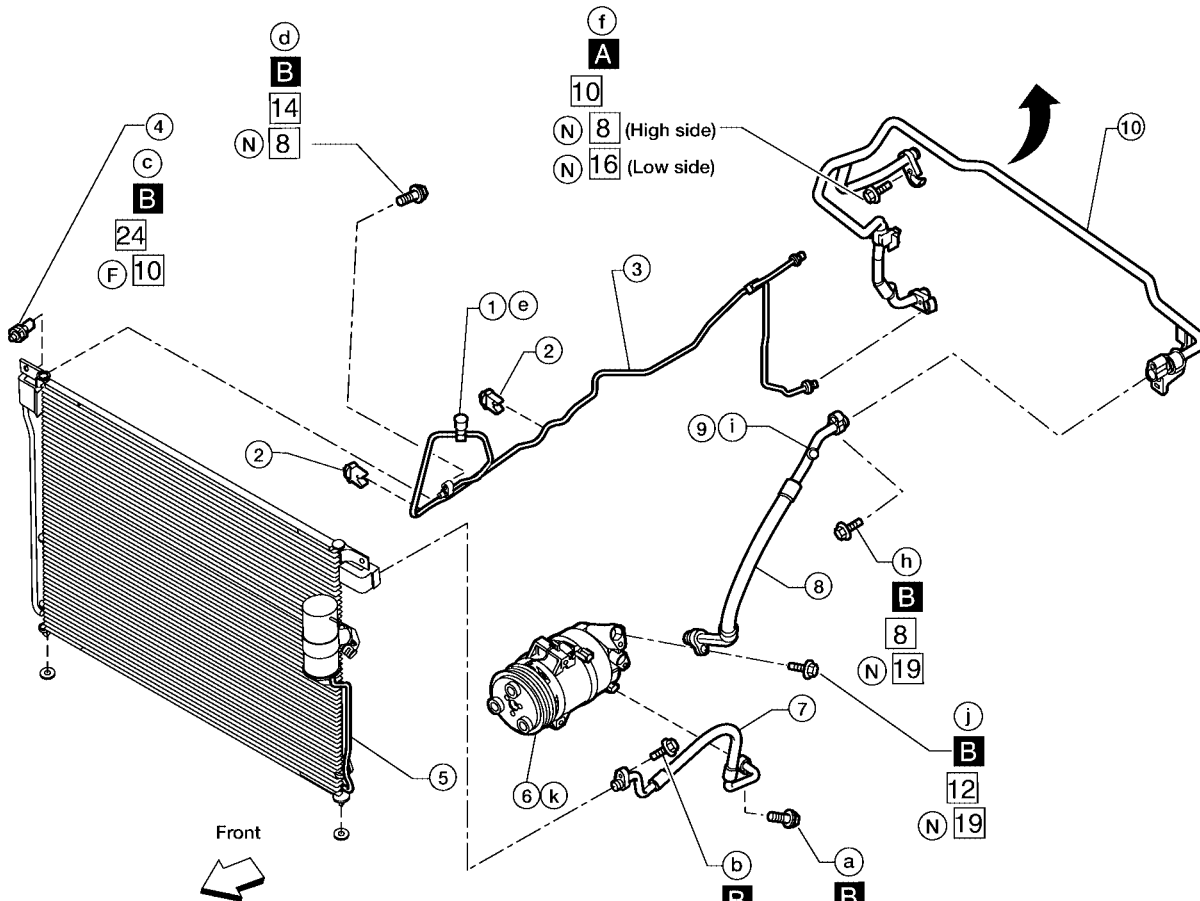
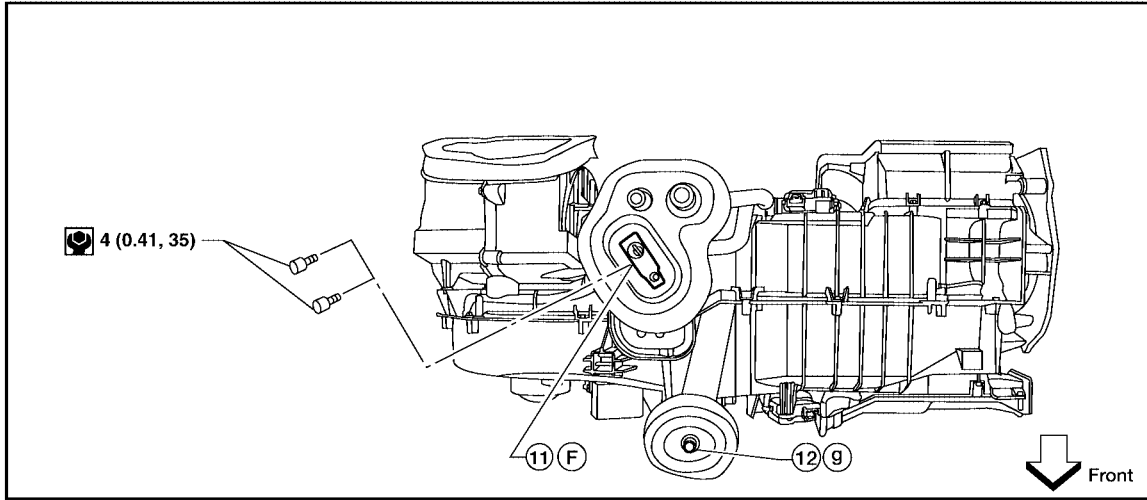

- : Refrigerant leak checking order (a-k)
- : Tightening torque
- : Wrench size
- : O-ring size
- ⊙ : N-m (kg-m, in-lb)
- A** : 3.4 (0.35, 30)
- B** : 9.3 (0.95, 82)
- (F) : Former type refrigerant connection
- (N) : New type refrigerant connection

WJIA1399E

# REFRIGERANT LINES

- |  |   |                                 |
|--|---|---------------------------------|
| 1. High-pressure service valve           | 2. Clip                                 | 3. Front high-pressure A/C pipe |
| 4. Refrigerant pressure sensor           | 5. Condenser                            | 6. Compressor shaft seal        |
| 7. Front high-pressure flexible A/C hose | 8. Front low-pressure flexible A/C hose | 9. Low-pressure service valve   |
| 10. Front low-pressure A/C pipe          | 11. Front expansion valve               | 12. Front A/C drain hose        |

## Rear A/C

SEC. 214 • 271 • 274 • 276

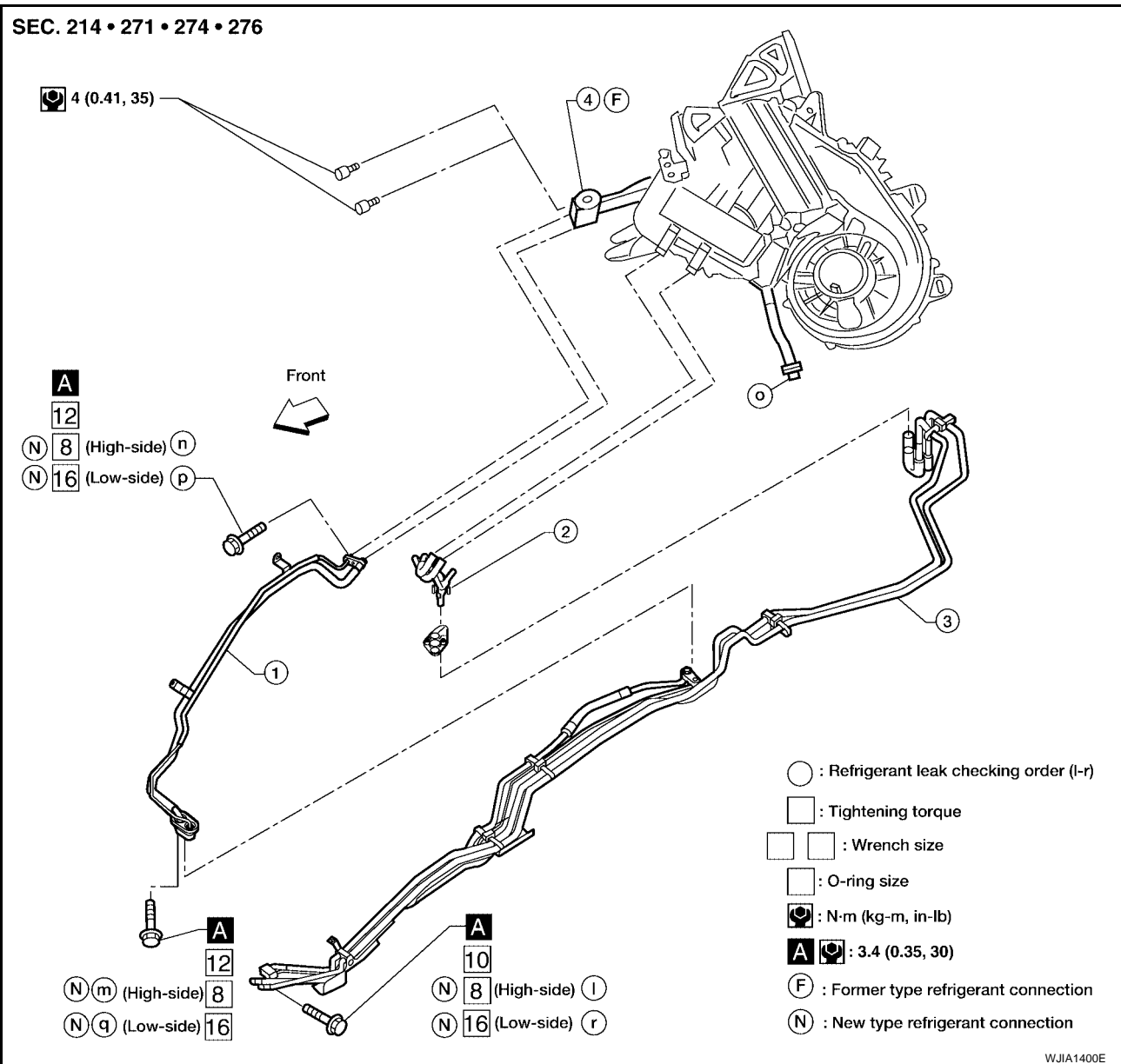

- |  |                           |   |
|--|---------------------------|---|
| 1. Rear high- and low-pressure A/C pipes | 2. Rear heater core hoses | 3. Underfloor rear high- and low-pressure A/C and heater core pipes |
| 4. Rear expansion valve                  |                           |   |

**NOTE:**

Refer to [ATC-6, "Precautions for Refrigerant Connection"](#) .

# REFRIGERANT LINES

EJS004Q8

## Removal and Installation for Compressor

### A/C Compressor Mounting

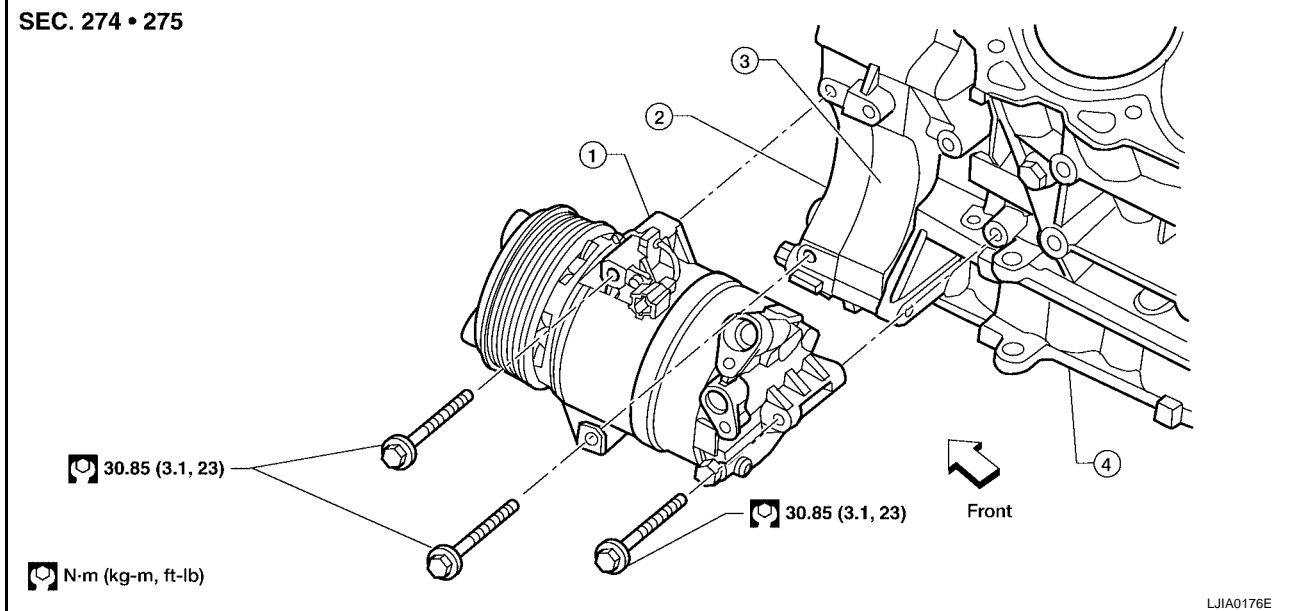

1. Compressor
2. Front timing chain case
3. Rear timing chain case
4. Cylinder block

### REMOVAL

1. Discharge the A/C refrigerant. Refer to [ATC-154, "HFC-134a \(R-134a\) Service Procedure"](#).
2. Remove the front left wheel and tire assembly. Refer to [WT-7, "Rotation"](#).
3. Remove the engine cover.
4. Remove the front left mud guard.
5. Remove the front left splash shield.
6. Remove the engine air cleaner and air ducts. Refer to [EM-16, "AIR CLEANER AND AIR DUCT"](#).
7. Remove the drive belt. Refer to [EM-14, "DRIVE BELTS"](#).
8. Disconnect the compressor harness connector.
9. Disconnect both the front high-pressure flexible A/C hose and front low-pressure flexible A/C hose from the compressor.

#### CAUTION:

Cap or wrap the joint of the pipe with suitable material such as vinyl tape to avoid the entry of air.

10. Remove the A/C compressor bolts using power tools.

### INSTALLATION

Installation is in the reverse order of removal.

#### CAUTION:

- Replace the O-ring of the front low-pressure flexible A/C hose and front high-pressure flexible A/C hose with a new one, apply compressor oil to the O-rings before installation.
- After recharging the A/C system with refrigerant, check for leaks. Refer to [ATC-170, "Checking for Refrigerant Leaks"](#).



# REFRIGERANT LINES

5. Remove the pulley using Tool with a small adapter. Position the small adapter on the end of the drive shaft and the center of the pulley on the small adapter.

**Tool number** : KV99233130 (J-29884)

**CAUTION:**

To prevent deformation of the pulley groove, the puller claws should be hooked under the pulley groove and not into the pulley groove.

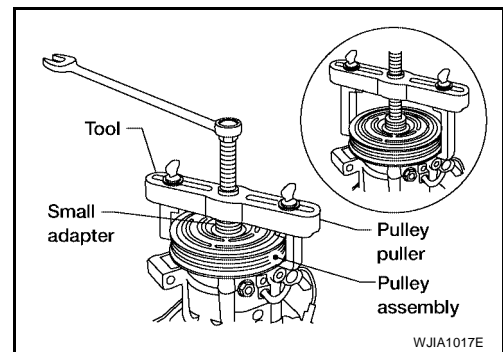

6. Remove the magnet coil harness clip using a screwdriver, remove the three magnet coil fixing screws and remove the magnet coil.

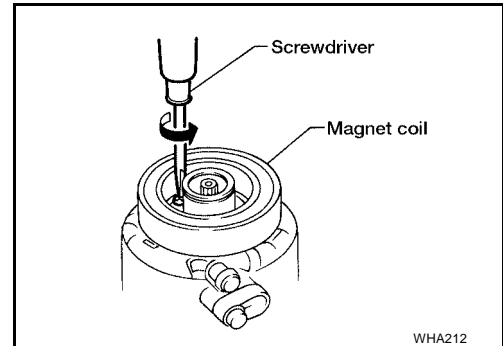

## INSPECTION

### Clutch Disc

If the contact surface shows signs of damage due to excessive heat, replace clutch disc and pulley.

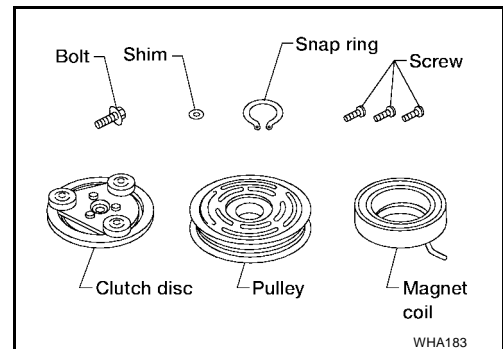

### Pulley

Check the appearance of the pulley assembly. If contact surface of pulley shows signs of excessive grooving, replace clutch disc and pulley. The contact surfaces of the pulley assembly should be cleaned with a suitable solvent before reinstallation.

### Coil

Check magnet coil for loose connections or any cracked insulation.

## INSTALLATION

1. Install the magnet coil.

**CAUTION:**

Be sure to align the magnet coil pin with the hole in the compressor front head.

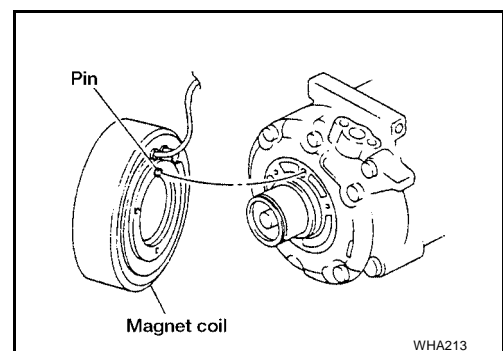



# REFRIGERANT LINES

2. Install the magnet coil harness clip using a screwdriver.
3. Install the pulley assembly using Tool and a wrench, then install the snap ring using snap ring pliers.

**Tool number : — (J-38873-A)**

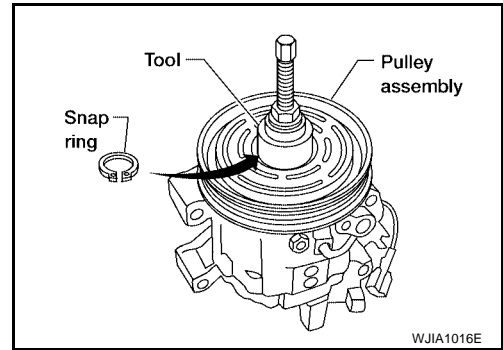

4. Install the clutch disc on the compressor shaft, together with the original shim(s). Press the clutch disc down by hand.

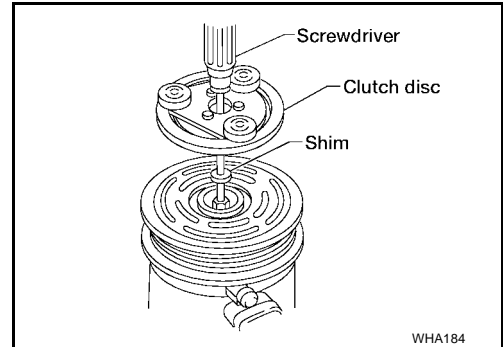

5. Install the clutch pulley bolt using Tool, to prevent the clutch disc from turning and tighten the bolt to specification. Refer to [ATC-156, "Components"](#).

**Tool number : J-44614**

**CAUTION:**

**After tightening the clutch pulley bolt, check that the clutch pulley rotates smoothly.**

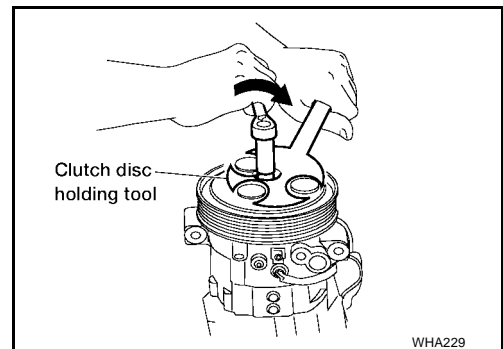

6. Check the pulley clearance all the way around the clutch disc as shown.

**Clutch disc-to-pulley clearance : 0.3 - 0.6 mm (0.012 - 0.024 in)**

7. If the specified clearance is not obtained, replace the adjusting spacer to readjust.
8. Install the compressor. Refer to [ATC-158, "Removal and Installation for Compressor"](#).

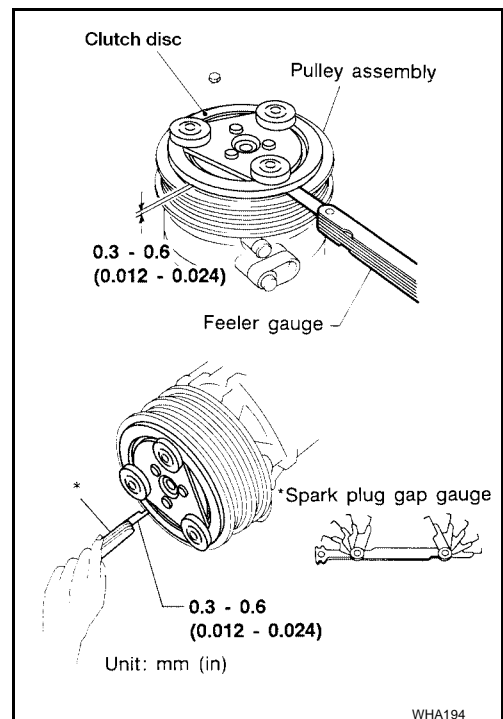

# REFRIGERANT LINES

## BREAK-IN OPERATION

When replacing compressor clutch assembly, always conduct the break-in operation. This is done by engaging and disengaging the clutch about 30 times. Break-in operation raises the level of transmitted torque.

## Removal and Installation for Front High-pressure Flexible A/C Hose

EJS004QA

### REMOVAL

1. Remove the front left wheel and tire assembly. Refer to [WT-7, "Rotation"](#) .
2. Remove the front left mud guard.
3. Remove the front left splash shield.
4. Discharge the refrigerant. Refer to [ATC-154, "HFC-134a \(R-134a\) Service Procedure"](#) .
5. Remove the front high-pressure flexible A/C hose. Refer to [ATC-156, "Components"](#) .

### CAUTION:

Cap or wrap the joint of the pipe with suitable material such as vinyl tape to avoid the entry of air.

### INSTALLATION

Installation is in the reverse order of removal.  
Refer to [ATC-156, "Components"](#) .

### CAUTION:

- Replace the O-ring of the front high-pressure flexible A/C hose with a new one, then apply compressor oil to it for installation.
- After charging refrigerant, check for leaks.

## Removal and Installation for Front High-pressure A/C Pipe

EJS004QB

### REMOVAL

1. Remove the front right wheel and tire assembly. Refer to [WT-7, "Rotation"](#) .
2. Remove the front right mud guard.
3. Remove the front right splash shield.
4. Discharge the refrigerant. Refer to [ATC-154, "HFC-134a \(R-134a\) Service Procedure"](#) .
5. Remove the front low pressure A/C pipe. Refer to [ATC-163, "Removal and Installation for Front Low-pressure A/C Pipe"](#) .
6. Remove the front high-pressure A/C pipe. Refer to [ATC-156, "Components"](#) .

### CAUTION:

Cap or wrap the joint of the pipe with suitable material such as vinyl tape to avoid the entry of air.

### INSTALLATION

Installation is in the reverse order of removal.  
Refer to [ATC-156, "Components"](#) .

### CAUTION:

- Replace the O-ring of the front high-pressure A/C pipe with a new one, then apply compressor oil to it for installation.
- After charging refrigerant, check for leaks.

## Removal and Installation for Front Low-pressure Flexible A/C Hose

EJS004QC

### REMOVAL

1. Remove the front right wheel and tire assembly. Refer to [WT-7, "Rotation"](#) .
2. Remove the front right mud guard.
3. Remove the front right splash shield.
4. Discharge the refrigerant. Refer to [ATC-154, "HFC-134a \(R-134a\) Service Procedure"](#) .

### CAUTION:

Cap or wrap the joint of the pipe with suitable material such as vinyl tape to avoid the entry of air.

5. Remove the front low-pressure flexible A/C hose. Refer to [ATC-156, "Components"](#) .

### INSTALLATION

Installation is in the reverse order of removal.  
Refer to [ATC-156, "Components"](#) .

# REFRIGERANT LINES

## CAUTION:

- Replace the O-ring of the front low-pressure flexible A/C hose with a new one, then apply compressor oil to it for installation.
- After charging refrigerant, check for leaks.

## Removal and Installation for Front Low-pressure A/C Pipe

EJS0040D

### REMOVAL

1. Discharge the refrigerant. Refer to [ATC-154, "HFC-134a \(R-134a\) Service Procedure"](#) .
2. Disconnect the heater pump connector.
3. Remove the heater pump from the bracket and reposition out of the way. Do not disconnect the heater hoses from the heater pump.
4. Remove the front low-pressure A/C pipe. Refer to [ATC-156, "Components"](#) .

## CAUTION:

Cap or wrap the joint of the pipe with suitable material such as vinyl tape to avoid the entry of air.

### INSTALLATION

Installation is in the reverse order of removal.  
Refer to [ATC-156, "Components"](#) .

## CAUTION:

- Replace the O-ring of the front low-pressure A/C pipe with a new one, then apply compressor oil to it for installation.
- After charging refrigerant, check for leaks.

## Removal and Installation for Rear High- and Low-pressure A/C Pipes

EJS0040E

### REMOVAL

1. Discharge the refrigerant. Refer to [ATC-154, "HFC-134a \(R-134a\) Service Procedure"](#) .
2. Remove the luggage side lower finisher RH. Refer to [EI-27, "Components"](#) .
3. Remove the rear high- and low-pressure A/C pipes. Refer to [ATC-156, "Components"](#) .

## CAUTION:

Cap or wrap the joint of the pipe with suitable material such as vinyl tape to avoid the entry of air.

### INSTALLATION

Installation is in the reverse order of removal.  
Refer to [ATC-156, "Components"](#) .

## CAUTION:

- Replace the O-ring of the rear high- and low-pressure A/C pipes with a new one, then apply compressor oil to it for installation.
- After charging refrigerant, check for leaks.

## Removal and Installation for Underfloor Rear High- and Low-pressure A/C and Heater Core Pipes

EJS0040F

### REMOVAL

1. Release the fuel pressure. Refer to [EC-79, "FUEL PRESSURE RELEASE"](#) .
2. Drain the engine coolant. Refer to [MA-13, "Changing Engine Coolant"](#) .
3. Disconnect the negative battery terminal.
4. Discharge the refrigerant. Refer to [ATC-154, "HFC-134a \(R-134a\) Service Procedure"](#) .
5. Remove the rear bumper. Refer to [EI-15, "REAR BUMPER"](#) .
6. Disconnect the fuel filler pipe and vent pipe from the lower fuel filler hose and fuel tank.
7. Remove the front fender protector. Refer to [EI-21, "Removal and Installation of Front Fender Protector"](#) .
8. Disconnect the chassis harness connector.
9. Remove the front and rear RH wheels and tires. Refer to [WT-6, "WHEEL AND TIRE ASSEMBLY"](#) .
10. Disconnect the fuel feed hose quick connectors. Disconnect the quick connectors as follows:
  - Hold the sides of the connector, push in the tabs and pull out the tube.
  - If the connector and the tube are stuck together, push and pull several times until they start to move. Then disconnect them by pulling.

# REFRIGERANT LINES

## CAUTION:

- The quick connector can be disconnected when the tabs are completely depressed. Do not twist the quick connector more than necessary.
- Do not use any tools to disconnect the quick connector.
- Keep the resin tube away from heat. Be especially careful when welding near the tube.
- Prevent any acid liquids such as battery electrolyte, from getting on the resin tube.
- Do not bend or twist the resin tube during connection.
- Do not remove the remaining retainer on the hard tube (or the equivalent) except when the resin tube or the retainer is replaced.
- When the resin tube or hard tube, or the equivalent, is replaced, also replace the retainer with a new one (semi-transparent colored retainer).

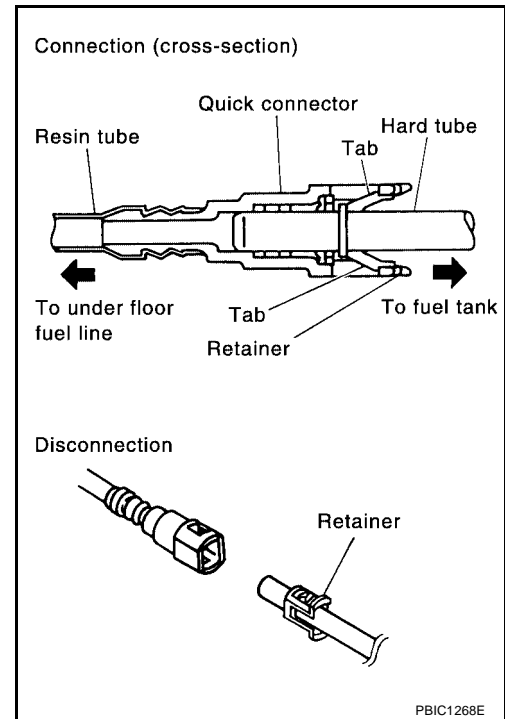

- To keep the quick connector clean and to avoid damage and contamination from foreign materials, cover the quick connector with plastic bags or suitable material as shown.

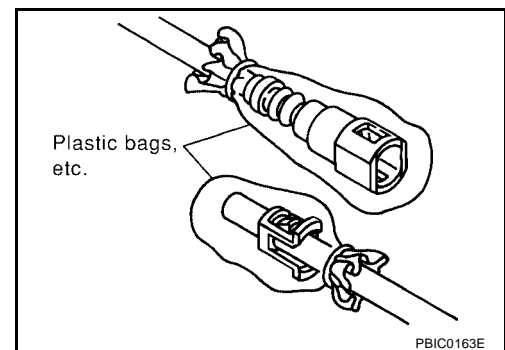

11. Disconnect the frame mounted brake tubes from the brake system. Refer to [BR-13, "BRAKE PIPING AND HOSE"](#) .
12. Remove the upper radiator mounting plates. Refer to [CO-14, "RADIATOR"](#) .
13. Disconnect the A/C lines ground strap.
14. Disconnect the exhaust system ground strap. Refer to [EX-3, "EXHAUST SYSTEM"](#) .
15. Disconnect each end of the underfloor rear high- and low-pressure A/C and heater core pipes. Refer to [ATC-156, "Components"](#) .

## CAUTION:

**Cap or wrap the joint of the pipes with suitable material such as vinyl tape to avoid the entry of air.**

16. Remove the front floor heat shield.
17. Remove the heater pipe heat shield.
18. Disconnect the steering column from the power steering gear. Refer to [PS-15, "POWER STEERING GEAR AND LINKAGE"](#) .
19. Set four suitable jacks at the body mount points to support the vehicle body when it is separated from the frame.
20. Remove the body mount bolts. Refer to [BL-123, "BODY REPAIR"](#) .
21. Use the vehicle hoist to lower the frame from the body [approximately 457 mm (18 in)] until there is sufficient clearance for the underfloor rear high- and low-pressure A/C and heater core pipes from the body.
22. Remove the underfloor rear high- and low-pressure A/C and heater core pipes.

# REFRIGERANT LINES

## INSTALLATION

Installation is in the reverse order of removal.

### CAUTION:

- Replace the O-ring of the underfloor rear high- and low-pressure A/C and heater core pipes with a new one, then apply compressor oil to it for installation.
- After charging refrigerant, check for leaks.
- Bleed the brake system. Refer to [BR-12, "Bleeding Brake System"](#) .

## Removal and Installation for Refrigerant Pressure Sensor

EJS004QG

### REMOVAL

1. Discharge the refrigerant. Refer to [ATC-154, "HFC-134a \(R-134a\) Service Procedure"](#) .
2. Disconnect the refrigerant pressure sensor harness connector and remove the refrigerant pressure sensor from the condenser.

### CAUTION:

Be careful not to damage the condenser fins.

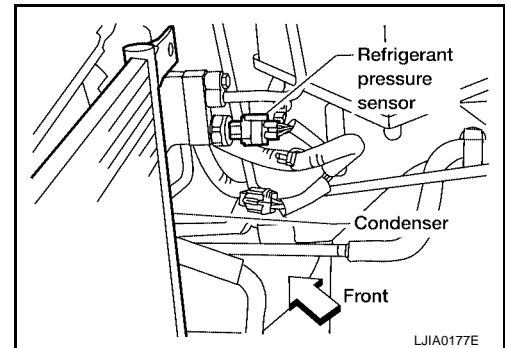

## INSTALLATION

Installation is in the reverse order of removal.

Refer to [ATC-156, "Components"](#) .

### CAUTION:

- Be careful not to damage the condenser fins.
- Replace the O-ring of the refrigerant pressure sensor with a new one, then apply compressor oil to it for installation.
- After charging refrigerant, check for leaks.

## Removal and Installation for Condenser

EJS004QH

### REMOVAL

1. Discharge the refrigerant. Refer to [ATC-154, "HFC-134a \(R-134a\) Service Procedure"](#) .
2. Remove the radiator. Refer to [CO-14, "RADIATOR"](#) .

### CAUTION:

Be careful not to damage the core surface of the condenser and the radiator.

3. Disconnect the front high-pressure flexible A/C hose and the front high-pressure A/C pipe from the condenser.

### CAUTION:

Cap or wrap the joint of the pipes with suitable material such as vinyl tape to avoid the entry of air.

4. Disconnect the refrigerant pressure sensor harness connector.
5. Remove the refrigerant pressure sensor from the condenser.
6. Lift the condenser out of the mounting grommets and remove the condenser.

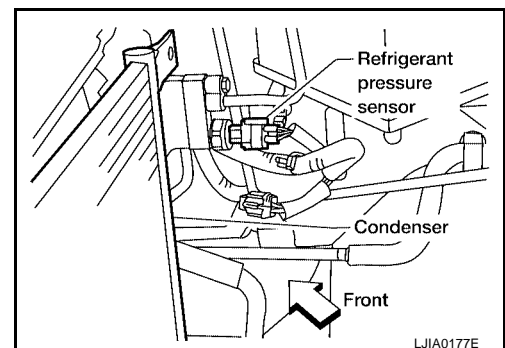

## INSTALLATION

Installation is in the reverse order of removal.

Refer to [ATC-156, "Components"](#) .

A  
B  
C  
D  
E  
F  
G  
H  
I  
K  
L  
M

ATC

# REFRIGERANT LINES

**CAUTION:**

- Replace the O-rings of the front high-pressure A/C pipe, refrigerant pressure sensor, and front high-pressure flexible A/C hose with new ones, then apply compressor oil to them for installation.
- After charging refrigerant, check for leaks.
- Replace the mounting grommets as necessary.

## Removal and Installation for Front Evaporator

EJS00401

### Front Heater and Cooling Unit Assembly

SEC. 270 • 271 • 272

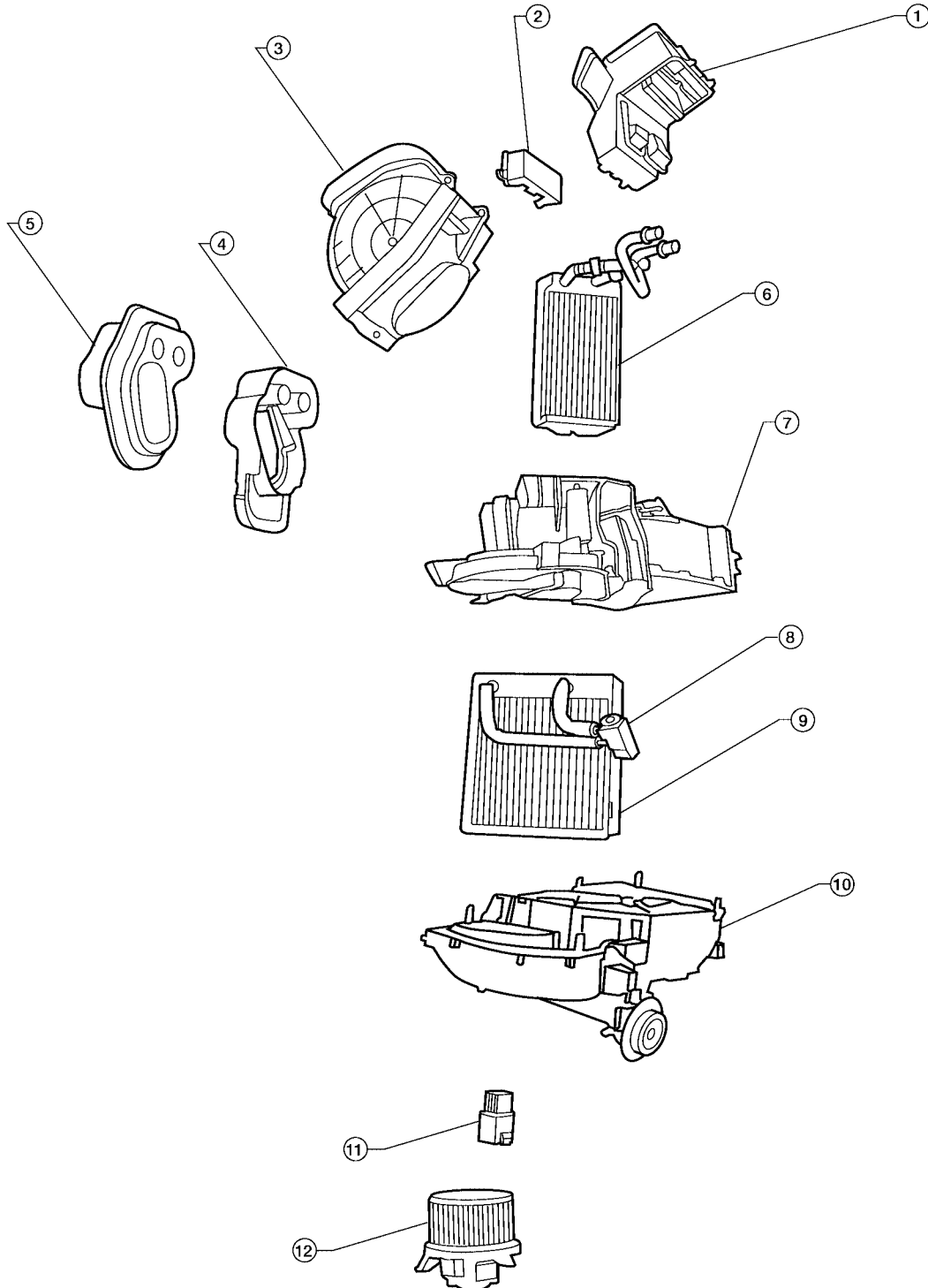

LJIA0178E

# REFRIGERANT LINES

- 
- |   |   |                      |   |
|---|---|----------------------|---|
| 1. Center ventilator connector duct               | 2. Front heater core cover                        | 3. Intake air case   | A |
| 4. Front heater core and evaporator pipes bracket | 5. Front heater core and evaporator pipes grommet | 6. Front heater core | B |
| 7. Upper heater and cooling unit case             | 8. Front expansion valve                          | 9. Front evaporator  | C |
| 10. Lower heater and cooling unit case            | 11. Variable blower control                       | 12. Blower motor     | D |

## REMOVAL

1. Remove the front heater core. Refer to [ATC-141, "FRONT HEATER CORE"](#).
2. Separate the heater and cooling unit case.
3. Remove the front evaporator.

## INSTALLATION

Installation is in the reverse order of removal.

### CAUTION:

Replace the O-rings on the front A/C low-pressure flexible A/C hose and the front high-pressure A/C pipe with new ones. Apply compressor oil to the O-rings for installation.

A  
B  
C  
D  
E  
F  
G  
H  
I  
K  
L  
M

ATC

# REFRIGERANT LINES

## Removal and Installation for Rear Evaporator

EJS0040J

### Rear Heater and Cooling Unit Assembly

SEC. 274

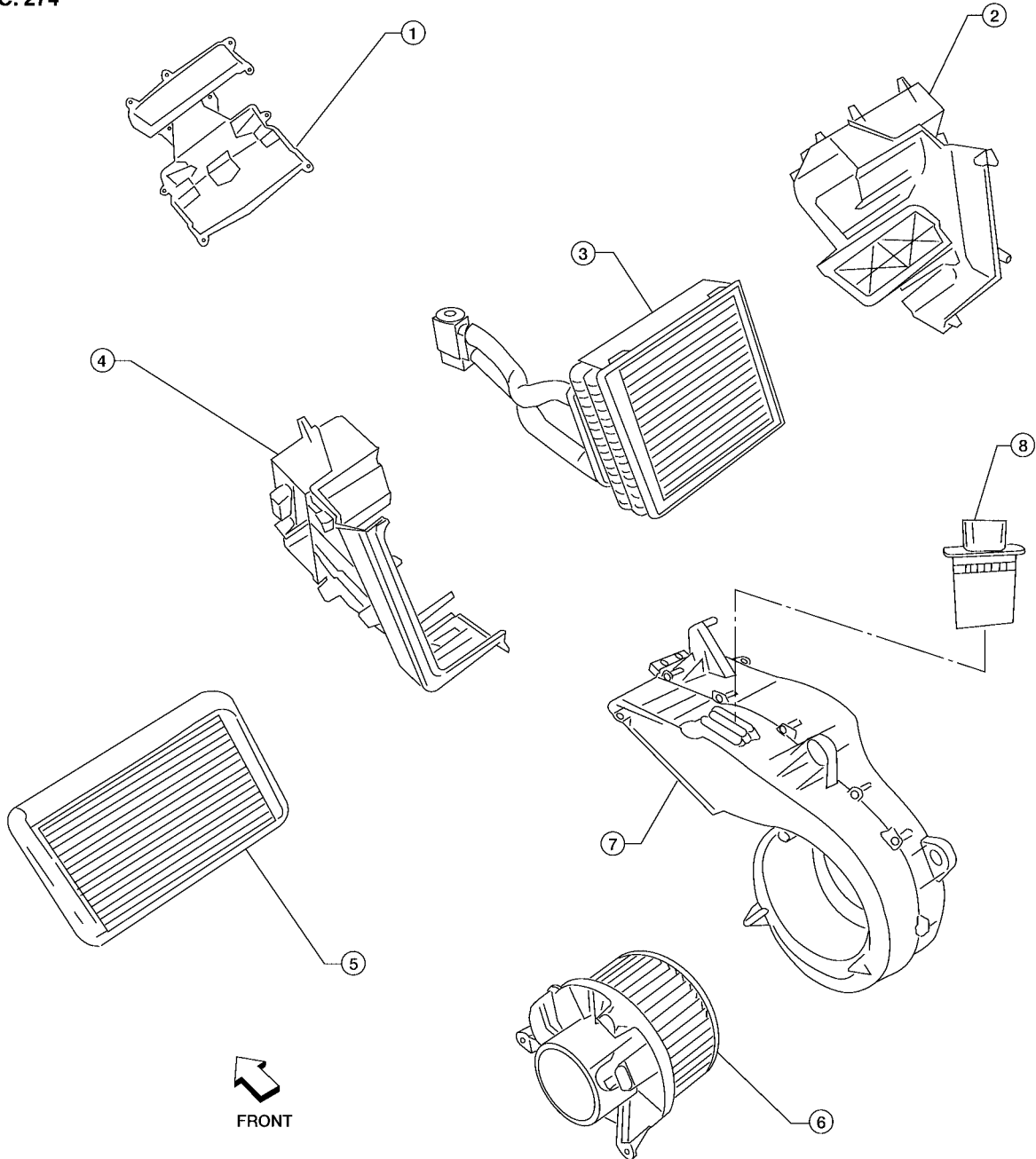

- |                      |   |                      |
|----------------------|---|----------------------|
| 1. Front cover       | 2. Rear evaporator and heater core case | 3. Rear evaporator   |
| 4. Side cover        | 5. Rear heater core                     | 6. Rear blower motor |
| 7. Blower motor case | 8. Rear blower motor resistor           |                      |

LJIA0135E

### REMOVAL

1. Remove the rear heater and cooling unit assembly from the vehicle. Refer to [ATC-138, "REAR HEATER AND COOLING UNIT ASSEMBLY"](#).
2. Remove the rear blower motor.
3. Remove the rear blower speed resistor.



# REFRIGERANT LINES

4. Remove the rear air mix door motor.
5. Remove the rear duct and blend door assembly. Refer to [ATC-151, "DEFROSTER NOZZLE"](#) .
6. Disassemble the rear heater and cooling unit assembly to remove the rear evaporator.

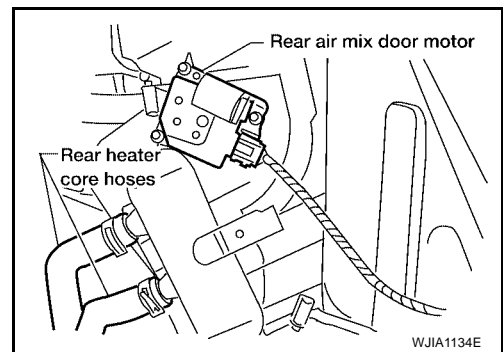

## INSTALLATION

Installation is in the reverse order of removal.

### CAUTION:

- Replace the O-rings on the rear high- and low-pressure A/C pipes with new ones. Apply compressor oil to the O-rings for installation.
- After charging refrigerant, check for leaks.

## Removal and Installation for Front Expansion Valve

EJS004QK

### REMOVAL

1. Discharge the refrigerant. Refer to [ATC-154, "HFC-134a \(R-134a\) Service Procedure"](#) .
2. Remove the front heater and cooling unit assembly. Refer to [ATC-137, "FRONT HEATER AND COOLING UNIT ASSEMBLY"](#) .
3. Remove the front heater core and evaporator pipes grommet.
4. Remove the front expansion valve.

### INSTALLATION

Installation is in the reverse order of removal.

Expansion valve bolts : Refer to [ATC-156, "Components"](#)

A/C refrigerant pipe to expansion valve bolt : Refer to [ATC-156, "Components"](#)

### CAUTION:

- Replace the O-rings on then front expansion valve and the A/C refrigerant pipes with new ones, then apply compressor oil to them for installation.
- After charging refrigerant, check for leaks.

## Removal and Installation for Rear Expansion Valve

EJS004QL

### REMOVAL

1. Discharge the refrigerant. Refer to [ATC-154, "HFC-134a \(R-134a\) Service Procedure"](#) .
2. Remove the luggage side lower finisher RH access door.
3. Disconnect the rear high- and low-pressure A/C pipes from the rear expansion valve.

### CAUTION:

Cap or wrap the A/C refrigerant pipe ends with a suitable material such as vinyl tape to avoid the entry of air and contaminants.

4. Remove the expansion valve.

### INSTALLATION

Installation is in the reverse order of removal.

Expansion valve bolts : Refer to [ATC-156, "Components"](#)

A/C refrigerant pipe to expansion valve bolt : Refer to [ATC-156, "Components"](#)

# REFRIGERANT LINES

## CAUTION:

- Replace the O-rings on the rear expansion valve and the rear high- and low-pressure A/C pipes with new ones, then apply compressor oil to them for installation.
- After charging refrigerant, check for leaks.

## Checking for Refrigerant Leaks

EJS004QM

Perform a visual inspection of all refrigeration parts, fittings, hoses and components for signs of A/C oil leakage, damage, and corrosion. Any A/C oil leakage may indicate an area of refrigerant leakage. Allow extra inspection time in these areas when using either an electronic refrigerant leak detector (J-41995) or fluorescent dye leak detector (J-42220).

If any dye is observed using a fluorescent dye leak detector (J-42220), confirm the leak using a electronic refrigerant leak detector (J-41995). It is possible that the dye is from a prior leak that was repaired and not properly cleaned.

When searching for leaks, do not stop when one leak is found but continue to check for additional leaks at all system components and connections.

When searching for refrigerant leaks using an electronic refrigerant leak detector (J-41995), move the probe along the suspected leak area at 25 - 50 mm (1 - 2 in) per second and no further than 6 mm (1/4 in) from the component.

## CAUTION:

**Moving the electronic refrigerant leak detector probe slower and closer to the suspected leak area will improve the chances of finding a leak.**

## Checking System for Leaks Using the Fluorescent Dye Leak Detector

EJS004QN

1. Check the A/C system for leaks using the fluorescent dye leak detector and safety goggles (J-42220) in a low sunlight area (area without windows preferable). Illuminate all components, fittings and lines. The dye will appear as a bright green/yellow area at the point of leakage. Fluorescent dye observed at the evaporator drain opening indicates an evaporator core assembly leak (tubes, core or expansion valve).
2. If the suspected area is difficult to see, use an adjustable mirror or wipe the area with a clean shop rag or cloth, then inspect the shop rag or cloth with the fluorescent dye leak detector (J-42220) for dye residue.
3. After the leak is repaired, remove any residual dye using refrigerant dye cleaner (J-43872) to prevent future misdiagnosis.
4. Perform a system performance check and then verify the leak repair using a electronic refrigerant leak detector (J-41995).

### NOTE:

- Other gases in the work area or substances on the A/C components, for example, anti-freeze, windshield washer fluid, solvents and oils, may falsely trigger the leak detector. Make sure the surfaces to be checked are clean.
- Clean with a dry cloth or blow off with shop air.
- Do not allow the sensor tip of the electronic refrigerant leak detector (J-41995) to contact with any substance. This can also cause false readings and may damage the detector.

## Dye Injection

EJS004QO

### NOTE:

This procedure is only necessary when recharging the system or when the compressor has seized and must be replaced.

1. Check the A/C system static (at rest) pressure. Pressure must be at least 345 kPa (3.52 kg/cm<sup>2</sup>, 50 psi).
2. Pour one bottle 7.4 cc (1/4 ounce) of the HFC-134a (R-134a) fluorescent leak detection dye (J-41447) into the HFC-134a (R-134a) refrigerant dye injector (J-41459).

### CAUTION:

**If repairing the A/C system or replacing a component, pour the HFC-134a (R-134a) fluorescent leak detection dye (J-41447) directly into the open system connection and proceed with the service procedures.**

3. Connect the refrigerant dye injector (J-41459) to the low-pressure service valve.
4. Start the engine and switch the A/C system ON.
5. When the A/C system is operating (compressor running), inject one bottle 7.4 cc (1/4 ounce) of HFC-134a (R-134a) fluorescent leak detection dye (J-41447) through the low-pressure service valve using HFC-134a (R-134a) refrigerant dye injector (J-41459). Refer to the manufacturer's operating instructions.

# REFRIGERANT LINES

6. With the engine still running, disconnect the HFC-134a (R-134a) refrigerant dye injector (J-41459) from the low-pressure service valve.
7. Operate the A/C system for a minimum of 20 minutes to mix the HFC-134a (R-134a) fluorescent leak detection dye (J-41447) with the A/C system oil. Depending on the leak size, operating conditions and location of the leak, it may take from minutes to days for the HFC-134a (R-134a) fluorescent leak detection dye to penetrate an A/C system leak and become visible.

## Electronic Refrigerant Leak Detector PRECAUTIONS FOR HANDLING LEAK DETECTOR

EJS004QP

### NOTE:

When performing a refrigerant leak check, use a electronic refrigerant leak detector (J-41995) or equivalent. Ensure that the electronic refrigerant leak detector (J-41995) is calibrated and set properly according to the manufacturer's operating instructions.

The electronic refrigerant leak detector (J-41995) is a delicate device. To use the electronic refrigerant leak detector (J-41995) properly, read the manufacturer's operating instructions and perform any specified maintenance.

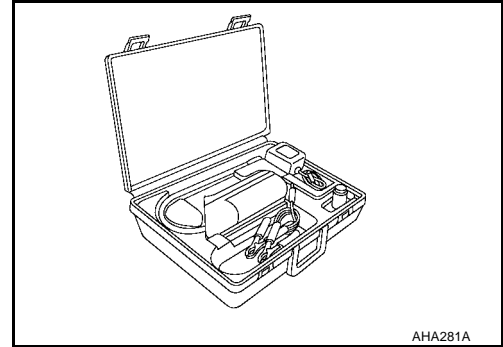

1. Position the probe approximately 5 mm (3/16 in) away from the point to be checked as shown.

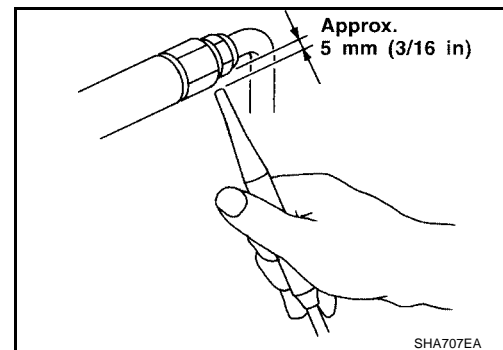

2. When checking for leaks, circle each fitting completely with the probe as shown.

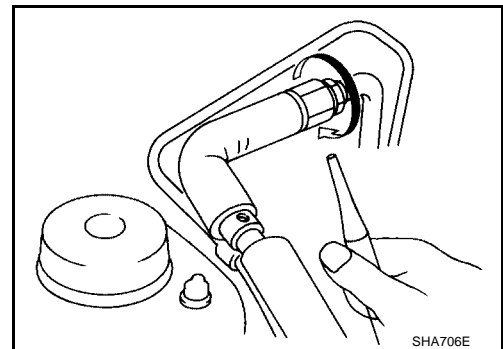

A  
B  
C  
D  
E  
F  
G  
H  
I  
ATC  
K  
L  
M

## REFRIGERANT LINES

3. Move the probe along each component at a speed of approximately 25 - 50 mm (1 - 2 in)/second as shown.

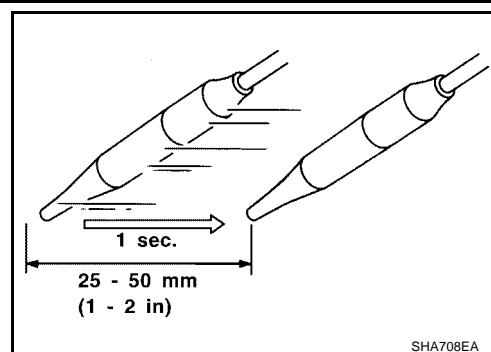

### CHECKING PROCEDURE

#### NOTE:

To prevent inaccurate or false readings, make sure there is no refrigerant vapor, shop chemicals, or cigarette smoke in the vicinity of the vehicle. Perform the leak test in a calm area (low air/wind movement) so that the leaking refrigerant is not dispersed.

1. Turn the engine OFF.
2. Connect the manifold gauge set (J-39183-C) to the A/C service ports. Refer to [ATC-154, "SETTING OF SERVICE TOOLS AND EQUIPMENT"](#).
3. Check if the A/C refrigerant pressure is at least 345 kPa (3.52 kg/cm<sup>2</sup>, 50 psi) above a temperature of 16°C (61°F). If less than specification, recover/evacuate and recharge the system with the specified amount of refrigerant. Refer to [ATC-154, "HFC-134a \(R-134a\) Service Procedure"](#).

#### NOTE:

At temperatures below 16°C (61°F), leaks may not be detected since the system may not reach 345 kPa (3.52 kg/cm<sup>2</sup>, 50 psi) pressure.

4. Perform the leak test from the high-pressure side (front A/C compressor discharge "a" to evaporator inlet "f" or rear piping connection "l") to the low-pressure side (front A/C evaporator drain hose "g" to shaft seal "k" and rear A/C evaporator drain hose "o" to piping connection "r"). Refer to [ATC-156, "Components"](#). Clean the component to be checked and carefully move the electronic refrigerant leak detector probe completely around the following connections and components.

- Check the compressor shaft seal
- Check the high and low-pressure pipe and hose fittings, relief valve, and compressor shaft seal
- Check the liquid tank
- Check the refrigerant pressure sensor
- Check all around the service valves. Check that the service valve caps are screwed tightly on the service valves (to prevent leaks).

#### NOTE:

After removing manifold gauge set (J-39183-C) from the service valves, wipe any residue from the service valves to prevent any false readings by the electronic refrigerant leak detector (J-41995).

- Evaporator  
With engine OFF, turn blower fan on "High" for at least 15 seconds to dissipate any refrigerant trace in the heater and cooling unit assembly. Wait a minimum of 10 minutes accumulation time (refer to the manufacturer's recommended procedure for actual wait time) before inserting the electronic refrigerant leak detector probe into the heater and cooling unit assembly drain hose.

#### NOTE:

Keep the probe inserted for at least 10 seconds. Use caution not to contaminate the probe tip with water or dirt that may be in the drain hose.

5. If a leak is detected, verify at least once by blowing compressed air into the area of the suspected leak, then repeat the leak check.
6. Do not stop when one leak is found. Continue to check for additional leaks at all system components and connections.
7. If no leaks are found, perform steps 8 - 11.
8. Start the engine.
9. Set the heater A/C controls as follows:

# REFRIGERANT LINES

## NOTE:

For the automatic system, turn OFF the automatic controls and set the A/C controls manually.

- a. A/C switch: ON
  - b. Air flow: VENT mode
  - c. Intake position: RECIRCULATION mode
  - d. Temperature: MAX cold
  - e. Blower fan speed: HIGH
10. Run the engine at 1,500 rpm for at least 2 minutes.
  11. Turn the engine OFF and perform the leak check again following steps 4 through 6 above.

Refrigerant leaks should be checked immediately after turning the engine OFF. Begin with the leak detector at the compressor. The pressure on the high pressure side will gradually drop after the refrigerant circulation stops and pressure on the low pressure side will gradually rise, as shown in the graph. Some leaks are more easily detected when the pressure is high.

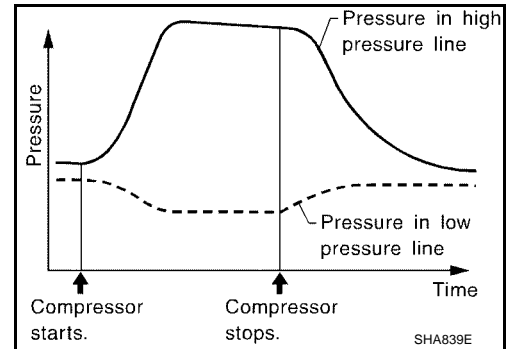

12. Before connecting the recovery/recycling equipment to the vehicle, check the recovery/recycling equipment gauges. No refrigerant pressure should be displayed. If pressure is displayed, recover the refrigerant from the equipment lines and then check the refrigerant purity.
13. Confirm refrigerant purity in supply tank using recovery/recycling equipment and refrigerant identifier equipment (J-41810-NI).
14. Confirm the refrigerant purity in the vehicle's A/C system using recovery/recycling equipment and refrigerant identifier equipment (J-41810-NI).
15. Discharge the A/C system using recovery/recycling equipment. Repair the leaking fitting or component as necessary.
16. Evacuate and recharge the A/C system and perform the leak test to confirm that there are no refrigerant leaks.
17. Conduct the Operational Check to ensure system works properly. Refer to [ATC-53, "Operational Check \(Front\)"](#).

A

B

C

D

E

F

G

H

I

ATC

K

L

M

# SERVICE DATA AND SPECIFICATIONS (SDS)

## SERVICE DATA AND SPECIFICATIONS (SDS)

PFP:00030

### Service Data and Specifications (SDS) COMPRESSOR

EJS00400

Make	ZEXEL VALEO CLIMATE CONTROL
Model	DKS-17D
Type	Swash plate
Displacement	175.5 cm <sup>3</sup> (10.7 in <sup>3</sup> ) / revolution
Cylinder bore × stroke	30.5 mm (1.20 in) x 24.0 mm (0.94 in)
Direction of rotation	Clockwise (viewed from drive end)
Drive belt	Poly V

### OIL

Name	NISSAN A/C System Oil Type S or equivalent
Capacity	210 mℓ (7.1 US fl oz, 7.4 Imp fl oz)

### REFRIGERANT

Type	HFC 134a (R-134a)
Capacity	0.85 ± 0.05 kg (1.87 ± 0.11 lb)

### ENGINE IDLING SPEED

Refer to [EC-75, "Idle Speed and Ignition Timing Check"](#) .

### BELT TENSION

Refer to [MA-13, "DRIVE BELT TENSION"](#) .