

SECTION GW

GLASSES, WINDOW SYSTEM & MIRRORS

CONTENTS

PRECAUTIONS	3	CAN Communication System Description	19	A
Precautions for Supplemental Restraint System (SRS) "AIR BAG" and "SEAT BELT PRE-TENSIONER"	3	Schematic	20	B
Handling for Adhesive and Primer	3	Wiring Diagram — WINDOW —	21	C
PREPARATION	4	Terminal and Reference Value for Main Power Window and Door Lock/Unlock Switch	26	D
Special Service Tool	4	Terminal and Reference Value for BCM	27	E
Commercial Service Tool	4	Work Flow	27	F
SQUEAK AND RATTLE TROUBLE DIAGNOSES	5	CONSULT-II Function (BCM)	27	G
Work Flow	5	CONSULT-II INSPECTION PROCEDURE	27	H
CUSTOMER INTERVIEW	5	ACTIVE TEST	28	GW
DUPLICATE THE NOISE AND TEST DRIVE	6	WORK SUPPORT	28	
CHECK RELATED SERVICE BULLETINS	6	DATA MONITOR	28	J
LOCATE THE NOISE AND IDENTIFY THE ROOT CAUSE	6	Trouble Diagnoses Symptom Chart	29	K
REPAIR THE CAUSE	6	BCM Power Supply and Ground Circuit Check	29	L
CONFIRM THE REPAIR	7	Main Power Window and Door Lock/Unlock Switch Power Supply and Ground Circuit Check	30	M
Generic Squeak and Rattle Troubleshooting	7	Front Power Window Motor LH Circuit Check	31	
INSTRUMENT PANEL	7	Front Power Window RH Circuit Check (Power Window and Door Lock/Unlock Switch RH Operation)..	32	
CENTER CONSOLE	7	Front Power Window RH Circuit Check (Main Power Window and Door Lock/Unlock Switch Operation)..	36	
DOORS	7	Limit Switch Circuit Check Front LH	38	
TRUNK	8	Encoder Circuit Check Front LH	40	
SUNROOF/HEADLINING	8	Door Switch Check	43	
OVERHEAD CONSOLE (FRONT AND REAR).....	8	Rear Power Window LH Circuit Check (Rear Power Window Switch LH Operation)	44	
SEATS	8	Rear Power Window LH Circuit Check (Main Power Window and Door Lock/Unlock Switch Operation)..	48	
UNDERHOOD	8	Rear Power Window RH Circuit Check (Rear Power Window Switch RH Operation)	50	
Diagnostic Worksheet	9	Rear Power Window RH Circuit Check (Main Power Window and Door Lock/Unlock Switch Operation)..	53	
WINDSHIELD GLASS	11	Rear Power Window Motor LH Circuit Check	55	
Removal and Installation	11	Rear Power Window Motor RH Circuit Check	56	
REMOVAL	11	FRONT DOOR GLASS AND REGULATOR	57	
INSTALLATION	11	Front Door Glass	57	
POWER WINDOW SYSTEM	15	REMOVAL	57	
Component Parts and Harness Connector Location..	15	INSTALLATION	57	
System Description	15			
MANUAL OPERATION	16			
AUTO OPERATION	18			
POWER WINDOW LOCK	18			
RETAINED POWER OPERATION	18			

FITTING INSPECTION	57	Schematic	72
Front Door Glass Regulator	58	Wiring Diagram — DEF —	73
REMOVAL	58	Terminal and Reference Value for BCM	76
DISASSEMBLY AND ASSEMBLY	58	Terminal and Reference Value for IPDM E/R	76
INSPECTION AFTER REMOVAL	58	Work Flow	76
INSTALLATION	59	CONSULT-II Function (BCM)	77
SETTING AFTER INSTALLATION	60	CONSULT-II BASIC OPERATION PROCEDURE	77
REAR DOOR GLASS AND REGULATOR	61	DATA MONITOR	78
Rear Door Glass	61	ACTIVE TEST	78
REMOVAL	61	Trouble Diagnoses Symptom Chart	78
INSTALLATION	61	BCM Power Supply and Ground Circuit Check	79
FITTING INSPECTION	61	Rear Window Defogger Switch Circuit Check	79
Rear Door Glass Regulator	62	Rear Window Defogger Circuit Check	80
REMOVAL	62	Door Mirror Defogger Power Supply Circuit Check	81
INSPECTION AFTER REMOVAL	62	Door Mirror LH Defogger Circuit Check	83
INSTALLATION	63	Door Mirror RH Defogger Circuit Check	84
SIDE WINDOW GLASS	64	Rear Window Defogger Signal Check (With NAVI)	85
Removal and Installation	64	Filament Check	85
REMOVAL	65	Filament Repair	86
INSTALLATION	65	REPAIR EQUIPMENT	86
GLASS HATCH	66	REPAIRING PROCEDURE	86
Removal and Installation	66	DOOR MIRROR	88
INSIDE MIRROR	68	Wiring Diagram — MIRROR —	88
Wiring Diagram — I/MIRR —	68	Door Mirror Assembly	90
Removal and Installation	69	REMOVAL	90
INSIDE MIRROR	69	INSTALLATION	90
REAR WINDOW DEFOGGER	70	Door Mirror Glass	91
Component Parts and Harness Connector Location	70	REMOVAL AND INSTALLATION	91
System Description	70		
CAN Communication System Description	71		

PRECAUTIONS

PRECAUTIONS

PFP:00001

Precautions for Supplemental Restraint System (SRS) “AIR BAG” and “SEAT BELT PRE-TENSIONER”

EIS007R2

The Supplemental Restraint System such as “AIR BAG” and “SEAT BELT PRE-TENSIONER”, used along with a front seat belt, helps to reduce the risk or severity of injury to the driver and front passenger for certain types of collision. This system includes seat belt switch inputs and dual stage front air bag modules. The SRS system uses the seat belt switches to determine the front air bag deployment, and may only deploy one front air bag, depending on the severity of a collision and whether the front occupants are belted or unbelted. Information necessary to service the system safely is included in the SRS and SB section of this Service Manual.

WARNING:

- To avoid rendering the SRS inoperative, which could increase the risk of personal injury or death in the event of a collision which would result in air bag inflation, all maintenance must be performed by an authorized NISSAN/INFINITI dealer.
- Improper maintenance, including incorrect removal and installation of the SRS, can lead to personal injury caused by unintentional activation of the system. For removal of Spiral Cable and Air Bag Module, see the SRS section.
- Do not use electrical test equipment on any circuit related to the SRS unless instructed to in this Service Manual. SRS wiring harnesses can be identified by yellow and/or orange harnesses or harness connectors.

Handling for Adhesive and Primer

EIS007R3

- Do not use an adhesive which is past its usable date. Shelf life of this product is limited to six months after the date of manufacture. Carefully adhere to the expiration or manufacture date printed on the box.
- Keep primers and adhesive in a cool, dry place. Ideally, they should be stored in a refrigerator.
- Open the seal of the primer and adhesive just before application. Discard the remainder.
- Before application, be sure to shake the primer container to stir the contents. If any floating material is found, do not use it.
- If any primer or adhesive contacts the skin, wipe it off with gasoline or equivalent and wash the skin with soap.
- When using primer and adhesive, always observe the precautions in the instruction manual.

A

B

C

D

E

F

G

H

GW

J

K

L

M

PREPARATION

PREPARATION

PFP:00002

Special Service Tool

EIS007R5

The actual shapes of Kent-Moore tools may differ from those of special service tools illustrated here.

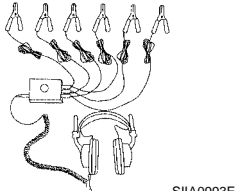
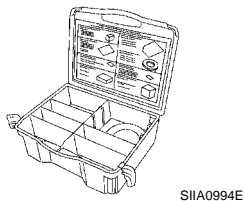
Tool number (Kent-Moore No.) Tool name		Description
— (J-39570) Chassis ear	 <p>SIA0993E</p>	Locating the noise
— (J-43980) NISSAN Squeak and Rattle Kit	 <p>SIA0994E</p>	Repairing the cause of noise

Commercial Service Tool

EIS007R6

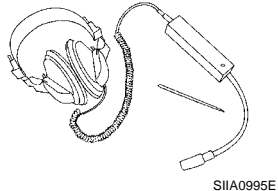
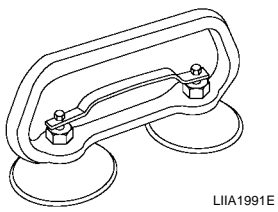
(Kent-Moore No.) Tool name		Description
(J-39565) Engine ear	 <p>SIA0995E</p>	Locating the noise
(—) Suction Lifter	 <p>LIA1991E</p>	Holding door glass

SQUEAK AND RATTLE TROUBLE DIAGNOSES

SQUEAK AND RATTLE TROUBLE DIAGNOSES

PFP:00000

Work Flow

EIS007R7

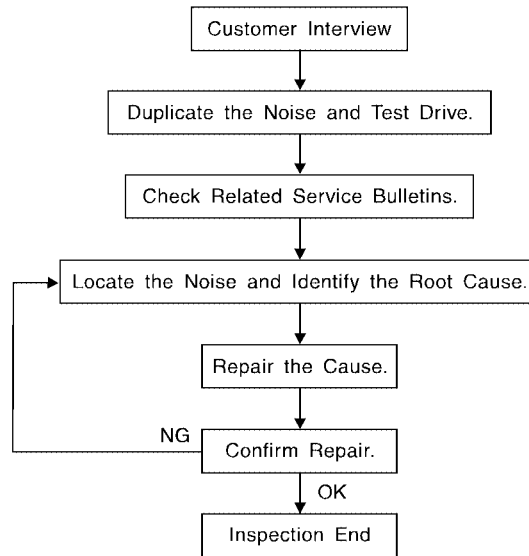

SBT842

CUSTOMER INTERVIEW

Interview the customer if possible, to determine the conditions that exist when the noise occurs. Use the Diagnostic Worksheet during the interview to document the facts and conditions when the noise occurs and any customer's comments; refer to [GW-9, "Diagnostic Worksheet"](#). This information is necessary to duplicate the conditions that exist when the noise occurs.

- The customer may not be able to provide a detailed description or the location of the noise. Attempt to obtain all the facts and conditions that exist when the noise occurs (or does not occur).
- If there is more than one noise in the vehicle, be sure to diagnose and repair the noise that the customer is concerned about. This can be accomplished by test driving the vehicle with the customer.
- After identifying the type of noise, isolate the noise in terms of its characteristics. The noise characteristics are provided so the customer, service adviser and technician are all speaking the same language when defining the noise.
- Squeak —(Like tennis shoes on a clean floor)
Squeak characteristics include the light contact/fast movement/brought on by road conditions/hard surfaces = higher pitch noise/softer surfaces = lower pitch noises/edge to surface = chirping.
- Creak—(Like walking on an old wooden floor)
Creak characteristics include firm contact/slow movement/twisting with a rotational movement/pitch dependent on materials/often brought on by activity.
- Rattle—(Like shaking a baby rattle)
Rattle characteristics include the fast repeated contact/vibration or similar movement/loose parts/missing clip or fastener/incorrect clearance.
- Knock —(Like a knock on a door)
Knock characteristics include hollow sounding/sometimes repeating/often brought on by driver action.
- Tick—(Like a clock second hand)
Tick characteristics include gentle contacting of light materials/loose components/can be caused by driver action or road conditions.
- Thump—(Heavy, muffled knock noise)
Thump characteristics include softer knock/dead sound often brought on by activity.
- Buzz—(Like a bumble bee)
Buzz characteristics include high frequency rattle/firm contact.
- Often the degree of acceptable noise level will vary depending upon the person. A noise that you may judge as acceptable may be very irritating to the customer.
- Weather conditions, especially humidity and temperature, may have a great effect on noise level.

SQUEAK AND RATTLE TROUBLE DIAGNOSES

DUPLICATE THE NOISE AND TEST DRIVE

If possible, drive the vehicle with the customer until the noise is duplicated. Note any additional information on the Diagnostic Worksheet regarding the conditions or location of the noise. This information can be used to duplicate the same conditions when you confirm the repair.

If the noise can be duplicated easily during the test drive, to help identify the source of the noise, try to duplicate the noise with the vehicle stopped by doing one or all of the following:

- 1) Close a door.
 - 2) Tap or push/pull around the area where the noise appears to be coming from.
 - 3) Rev the engine.
 - 4) Use a floor jack to recreate vehicle "twist".
 - 5) At idle, apply engine load (electrical load, half-clutch on M/T model, drive position on A/T model).
 - 6) Raise the vehicle on a hoist and hit a tire with a rubber hammer.
- Drive the vehicle and attempt to duplicate the conditions the customer states exist when the noise occurs.
 - If it is difficult to duplicate the noise, drive the vehicle slowly on an undulating or rough road to stress the vehicle body.

CHECK RELATED SERVICE BULLETINS

After verifying the customer concern or symptom, check ASIST for Technical Service Bulletins (TSBs) related to that concern or symptom.

If a TSB relates to the symptom, follow the procedure to repair the noise.

LOCATE THE NOISE AND IDENTIFY THE ROOT CAUSE

1. Narrow down the noise to a general area. To help pinpoint the source of the noise, use a listening tool (Chassis Ear: J-39570, Engine Ear: J-39565 and mechanic's stethoscope).
2. Narrow down the noise to a more specific area and identify the cause of the noise by:
 - removing the components in the area that you suspect the noise is coming from. Do not use too much force when removing clips and fasteners, otherwise clips and fasteners can be broken or lost during the repair, resulting in the creation of new noise.
 - tapping or pushing/pulling the component that you suspect is causing the noise. Do not tap or push/pull the component with excessive force, otherwise the noise will be eliminated only temporarily.
 - feeling for a vibration with your hand by touching the component(s) that you suspect is (are) causing the noise.
 - placing a piece of paper between components that you suspect are causing the noise.
 - looking for loose components and contact marks.
Refer to [GW-7, "Generic Squeak and Rattle Troubleshooting"](#) .

REPAIR THE CAUSE

- If the cause is a loose component, tighten the component securely.
- If the cause is insufficient clearance between components:
 - separate components by repositioning or loosening and retightening the component, if possible.
 - insulate components with a suitable insulator such as urethane pads, foam blocks, felt cloth tape or urethane tape. A NISSAN Squeak and Rattle Kit (J-43980) is available through your authorized NISSAN Parts Department.

CAUTION:

Do not use excessive force as many components are constructed of plastic and may be damaged.

Always check with the Parts Department for the latest parts information.

The following materials are contained in the NISSAN Squeak and Rattle Kit (J-43980). Each item can be ordered separately as needed.

URETHANE PADS [1.5 mm (0.059 in) thick]

Insulates connectors, harness, etc.

76268-9E005: 100×135 mm (3.94×5.31 in)/76884-71L01: 60×85 mm (2.36×3.35 in)/76884-71L02: 15×25 mm (0.59×0.98 in)

INSULATOR (Foam blocks)

Insulates components from contact. Can be used to fill space behind a panel.

73982-9E000: 45 mm (1.77 in) thick, 50×50 mm (1.97×1.97 in)/73982-50Y00: 10 mm (0.39 in) thick, 50×50 mm (1.97×1.97 in)

INSULATOR (Light foam block)

SQUEAK AND RATTLE TROUBLE DIAGNOSES

80845-71L00: 30 mm (1.18 in) thick, 30×50 mm (1.18×1.97 in)

FELT CLOTH TAPE

Used to insulate where movement does not occur. Ideal for instrument panel applications.

68370-4B000: 15×25 mm (0.59×0.98 in) pad/68239-13E00: 5 mm (0.20 in) wide tape roll. The following materials not found in the kit can also be used to repair squeaks and rattles.

UHMW (TEFLON) TAPE

Insulates where slight movement is present. Ideal for instrument panel applications.

SILICONE GREASE

Used instead of UHMW tape that will be visible or not fit.

Note: Will only last a few months.

SILICONE SPRAY

Use when grease cannot be applied.

DUCT TAPE

Use to eliminate movement.

CONFIRM THE REPAIR

Confirm that the cause of a noise is repaired by test driving the vehicle. Operate the vehicle under the same conditions as when the noise originally occurred. Refer to the notes on the Diagnostic Worksheet.

Generic Squeak and Rattle Troubleshooting

EIS007R8

Refer to Table of Contents for specific component removal and installation information.

INSTRUMENT PANEL

Most incidents are caused by contact and movement between:

1. The cluster lid A and instrument panel
2. Acrylic lens and combination meter housing
3. Instrument panel to front pillar garnish
4. Instrument panel to windshield
5. Instrument panel mounting pins
6. Wiring harnesses behind the combination meter
7. A/C defroster duct and duct joint

These incidents can usually be located by tapping or moving the components to duplicate the noise or by pressing on the components while driving to stop the noise. Most of these incidents can be repaired by applying felt cloth tape or silicone spray (in hard to reach areas). Urethane pads can be used to insulate wiring harness.

CAUTION:

Do not use silicone spray to isolate a squeak or rattle. If you saturate the area with silicone, you will not be able to recheck the repair.

CENTER CONSOLE

Components to pay attention to include:

1. Shifter assembly cover to finisher
2. A/C control unit and cluster lid C
3. Wiring harnesses behind audio and A/C control unit

The instrument panel repair and isolation procedures also apply to the center console.

DOORS

Pay attention to the:

1. Finisher and inner panel making a slapping noise
2. Inside handle escutcheon to door finisher
3. Wiring harnesses tapping
4. Door striker out of alignment causing a popping noise on starts and stops

Tapping or moving the components or pressing on them while driving to duplicate the conditions can isolate many of these incidents. You can usually insulate the areas with felt cloth tape or insulator foam blocks from the NISSAN Squeak and Rattle Kit (J-43980) to repair the noise.

SQUEAK AND RATTLE TROUBLE DIAGNOSES

TRUNK

Trunk noises are often caused by a loose jack or loose items put into the trunk by the owner. In addition look for:

1. Trunk lid bumpers out of adjustment
2. Trunk lid striker out of adjustment
3. The trunk lid torsion bars knocking together
4. A loose license plate or bracket

Most of these incidents can be repaired by adjusting, securing or insulating the item(s) or component(s) causing the noise.

SUNROOF/HEADLINING

Noises in the sunroof/headlining area can often be traced to one of the following:

1. Sunroof lid, rail, linkage or seals making a rattle or light knocking noise
2. Sun visor shaft shaking in the holder
3. Front or rear windshield touching headliner and squeaking

Again, pressing on the components to stop the noise while duplicating the conditions can isolate most of these incidents. Repairs usually consist of insulating with felt cloth tape.

OVERHEAD CONSOLE (FRONT AND REAR)

Overhead console noises are often caused by the console panel clips not being engaged correctly. Most of these incidents are repaired by pushing up on the console at the clip locations until the clips engage.

In addition look for:

1. Loose harness or harness connectors.
2. Front console map/reading lamp lense loose.
3. Loose screws at console attachment points.

SEATS

When isolating seat noise it's important to note the position the seat is in and the load placed on the seat when the noise is present. These conditions should be duplicated when verifying and isolating the cause of the noise.

Cause of seat noise include:

1. Headrest rods and holder
2. A squeak between the seat pad cushion and frame
3. The rear seatback lock and bracket

These noises can be isolated by moving or pressing on the suspected components while duplicating the conditions under which the noise occurs. Most of these incidents can be repaired by repositioning the component or applying urethane tape to the contact area.

UNDERHOOD

Some interior noise may be caused by components under the hood or on the engine wall. The noise is then transmitted into the passenger compartment.

Causes of transmitted underhood noise include:

1. Any component mounted to the engine wall
2. Components that pass through the engine wall
3. Engine wall mounts and connectors
4. Loose radiator mounting pins
5. Hood bumpers out of adjustment
6. Hood striker out of adjustment

These noises can be difficult to isolate since they cannot be reached from the interior of the vehicle. The best method is to secure, move or insulate one component at a time and test drive the vehicle. Also, engine RPM or load can be changed to isolate the noise. Repairs can usually be made by moving, adjusting, securing, or insulating the component causing the noise.

SQUEAK AND RATTLE TROUBLE DIAGNOSES

Diagnostic Worksheet

EIS007R9



SQUEAK & RATTLE DIAGNOSTIC WORKSHEET

Dear Nissan Customer:

We are concerned about your satisfaction with your Nissan vehicle. Repairing a squeak or rattle sometimes can be very difficult. To help us fix your Nissan right the first time, please take a moment to note the area of the vehicle where the squeak or rattle occurs and under what conditions. You may be asked to take a test drive with a service advisor or technician to ensure we confirm the noise you are hearing.

I. WHERE DOES THE NOISE COME FROM? (circle the area of the vehicle)

The illustrations are for reference only, and may not reflect the actual configuration of your vehicle.

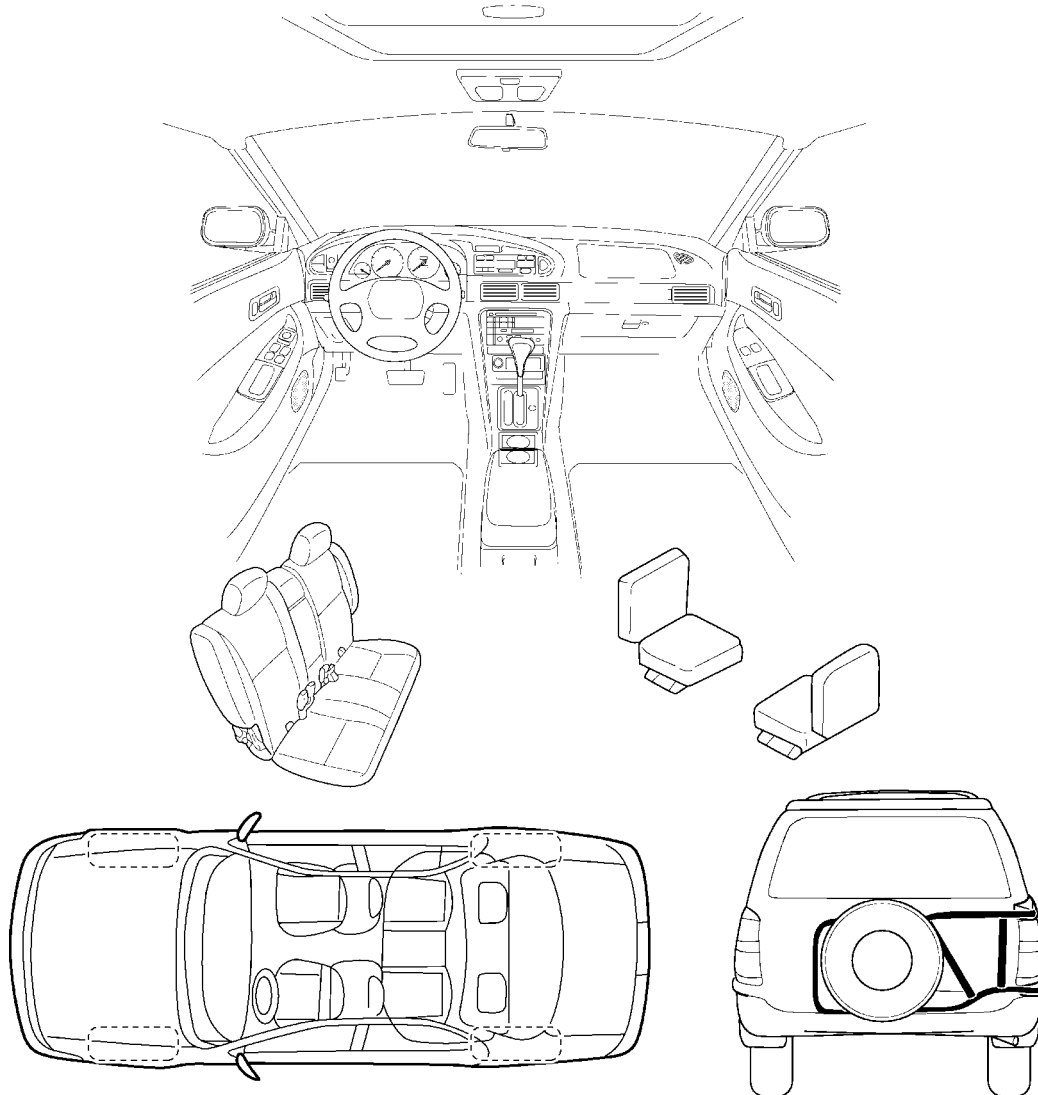

Continue to the back of the worksheet and briefly describe the location of the noise or rattle. In addition, please indicate the conditions which are present when the noise occurs.

LIWA0276E

A
B
C
D
E
F
G
H
GW
J
K
L
M

SQUEAK AND RATTLE TROUBLE DIAGNOSES

SQUEAK & RATTLE DIAGNOSTIC WORKSHEET- page 2

Briefly describe the location where the noise occurs:

II. WHEN DOES IT OCCUR? (check the boxes that apply)

- | | |
|--|---|
| <input type="checkbox"/> anytime | <input type="checkbox"/> after sitting out in the sun |
| <input type="checkbox"/> 1 st time in the morning | <input type="checkbox"/> when it is raining or wet |
| <input type="checkbox"/> only when it is cold outside | <input type="checkbox"/> dry or dusty conditions |
| <input type="checkbox"/> only when it is hot outside | <input type="checkbox"/> other: _____ |

III. WHEN DRIVING:

- through driveways
- over rough roads
- over speed bumps
- only at about ____ mph
- on acceleration
- coming to a stop
- on turns : left, right or either (circle)
- with passengers or cargo
- other: _____
- after driving ____ miles or ____ minutes

IV. WHAT TYPE OF NOISE?

- squeak (like tennis shoes on a clean floor)
- creak (like walking on an old wooden floor)
- rattle (like shaking a baby rattle)
- knock (like a knock on a door)
- tick (like a clock second hand)
- thump (heavy, muffled knock noise)
- buzz (like a bumble bee)

TO BE COMPLETED BY DEALERSHIP PERSONNEL

Test Drive Notes:

	YES	NO	Initials of person performing
Vehicle test driven with customer	<input type="checkbox"/>	<input type="checkbox"/>	_____
- Noise verified on test drive	<input type="checkbox"/>	<input type="checkbox"/>	_____
- Noise source located and repaired	<input type="checkbox"/>	<input type="checkbox"/>	_____
- Follow up test drive performed to confirm repair	<input type="checkbox"/>	<input type="checkbox"/>	_____

VIN: _____ Customer Name: _____

W.O. #: _____ Date: _____

SBT844

This form must be attached to Work Order

WINDSHIELD GLASS

PFP:72712

EIS007RA

WINDSHIELD GLASS Removal and Installation

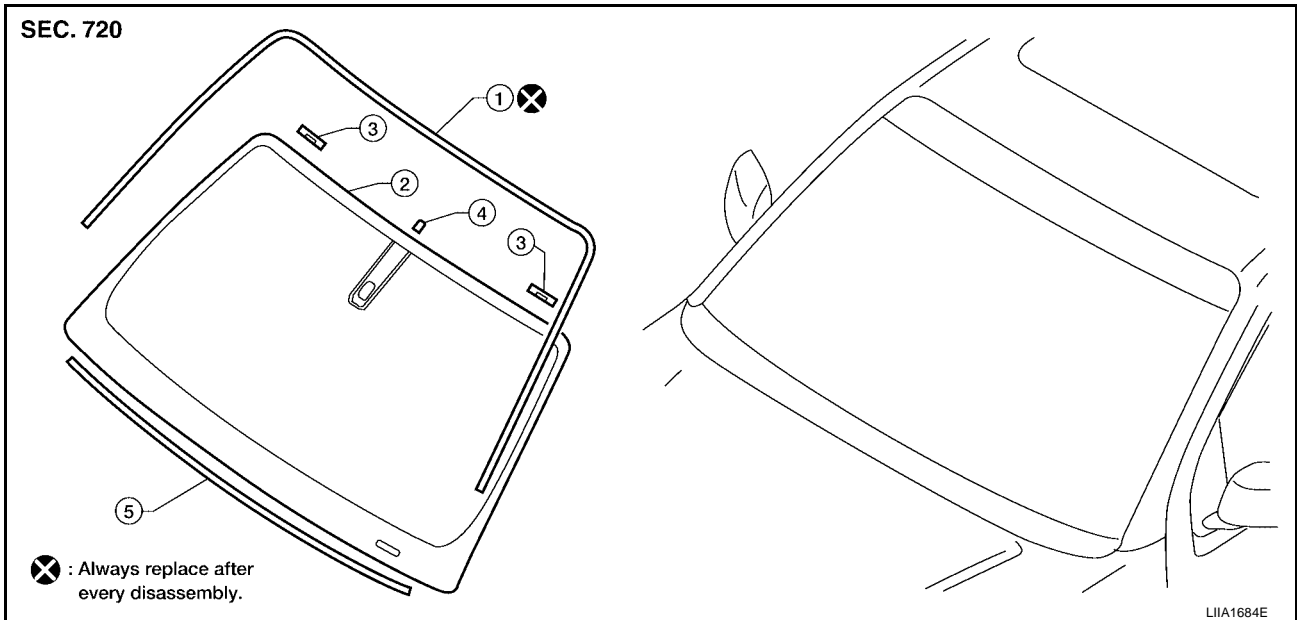

- | | | |
|----------------|---------------|-----------------------------|
| 1. Molding | 2. Windshield | 3. Windshield position pins |
| 4. Mirror base | 5. Insulator | |

REMOVAL

1. Remove inside mirror. Refer to [GW-69, "Removal and Installation"](#).
2. Partially remove the headlining (front edge). Refer to [EI-30, "Removal and Installation"](#).
3. Remove cowl top cover. Refer to [EI-17, "Removal and Installation"](#).
4. Apply a protective tape around the windshield glass to protect the painted surface from damage.
 - If the windshield glass is to be reused, mark the body and the glass with mating marks.
 - Remove glass using piano wire or power cutting tool and an inflatable pump bag.

WARNING:

When cutting the glass from the vehicle, always wear safety glasses and heavy gloves to help prevent glass splinters from entering your eyes or cutting your hands.

CAUTION:

- When the windshield glass is to be reused, do not use a cutting knife or power cutting tool.
- Be careful not to scratch the glass when removing.
- Do not set or stand glass on its edge. Small chips may develop into cracks.

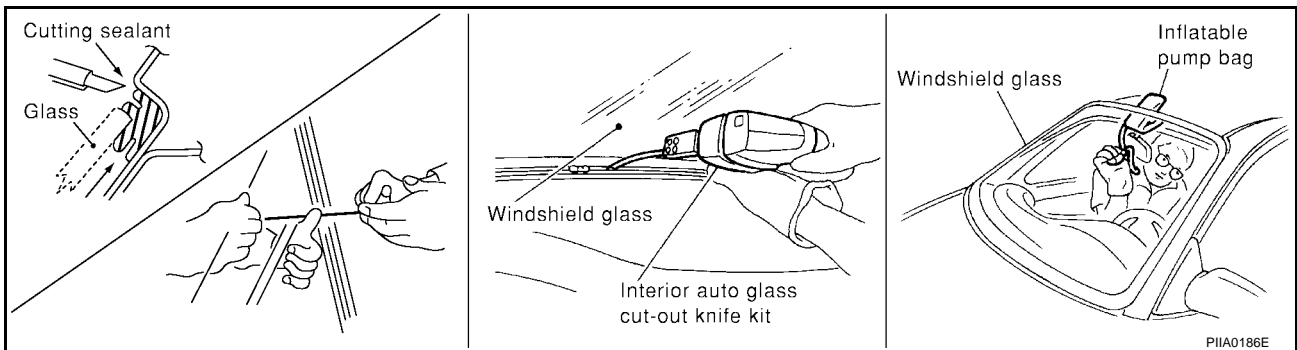

INSTALLATION

- Use a genuine NISSAN Urethane Adhesive Kit (if available) or equivalent and follow the instructions furnished with it.

WINDSHIELD GLASS

- While the urethane adhesive is curing, open a door window. This will prevent the glass from being forced out by passenger compartment air pressure when a door is closed.
- The molding must be installed securely so that it is in position and leaves no gap.
- Inform the customer that the vehicle should remain stationary until the urethane adhesive has completely cured (preferably 24 hours). Curing time varies with temperature and humidity.
- Install parts removed.

WARNING:

- **Keep heat and open flames away as primers and adhesive are flammable.**
- **The materials contained in the kit are harmful if swallowed, and may irritate skin and eyes. Avoid contact with the skin and eyes.**
- **Use in an open, well ventilated location. Avoid breathing the vapors. They can be harmful if inhaled. If affected by vapor inhalation, immediately move to an area with fresh air.**
- **Driving the vehicle before the urethane adhesive has completely cured may affect the performance of the windshield in case of an accident.**

CAUTION:

- **Do not use an adhesive which is past its usable term. Shelf life of this product is limited to six months after the date of manufacture. Carefully adhere to the expiration or manufacture date printed on the box.**
- **Keep primers and adhesive in a cool, dry place. Ideally, they should be stored in a refrigerator.**
- **Do not leave primers or adhesive cartridge unattended with their caps open or off.**
- **The vehicle should not be driven for at least 24 hours or until the urethane adhesive has completely cured. Curing time varies depending on temperature and humidities. The curing time will increase under lower temperatures and lower humidities.**

WINDSHIELD GLASS

SEC. 720

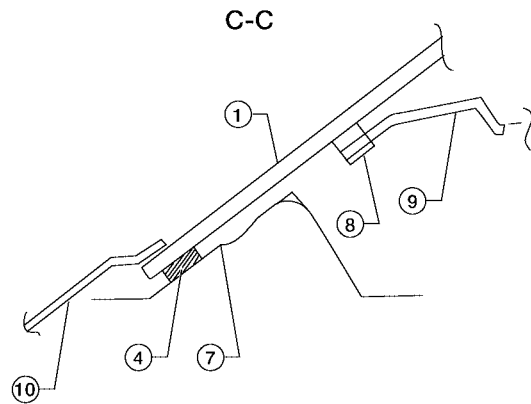
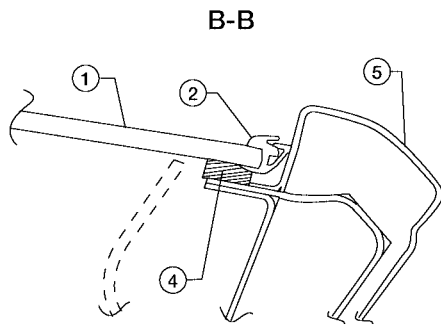
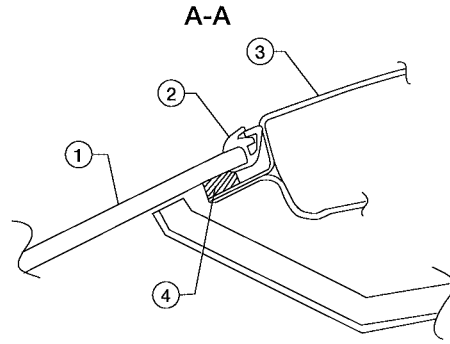
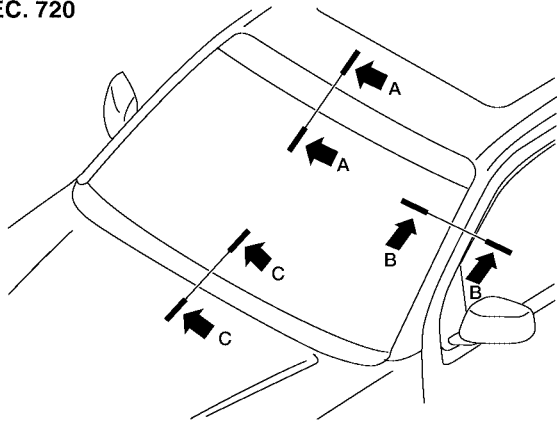

A

B

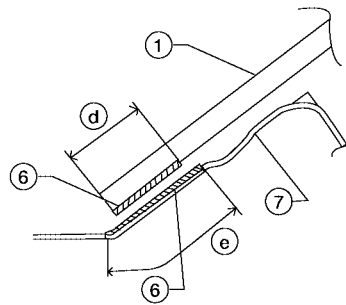
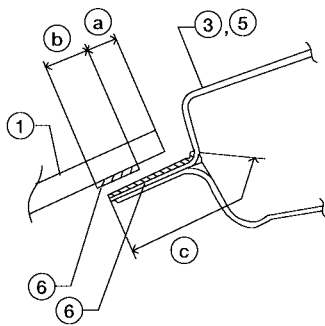

C

D

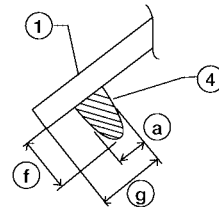
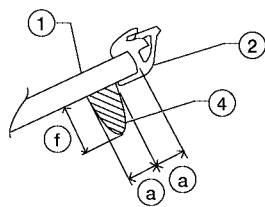

- 1. Windshield glass
- 4. Urethane
- 7. Cowl top panel

- 2. Molding
- 5. A-pillar
- 8. Insulator

- 3. Roof
- 6. Primer
- 9. Instrument panel

WIIA1032E

A
B
C
D
E
F
G
H
GW
J
K
L
M

WINDSHIELD GLASS

- | | | |
|------------------------------|--------------------------------|-------------------------|
| 10. Cowl top cover | A. Primer area (top and sides) | B. Primer area (bottom) |
| C. Bond area (top and sides) | D. Bond area (bottom) | a. 7.0 mm (0.27 in) |
| b. 10.0 mm (0.39 in) | c. 22.0 mm (0.78 in) | d. 20.0 mm (0.78 in) |
| e. 28.0 mm (1.10 in) | f. 12.0 mm (0.47 in) | g. 15.0 mm (0.59 in) |

Repairing Water Leaks for Windshield

Leaks can be repaired without removing and reinstalling glass.

If water is leaking between the urethane adhesive material and body or glass, determine the extent of leakage.

This can be done by applying water to the windshield area while pushing glass outward.

To stop the leak, apply primer (if necessary) and then urethane adhesive to the leak point.

POWER WINDOW SYSTEM

PFP:25401

EIS007RB

POWER WINDOW SYSTEM

Component Parts and Harness Connector Location

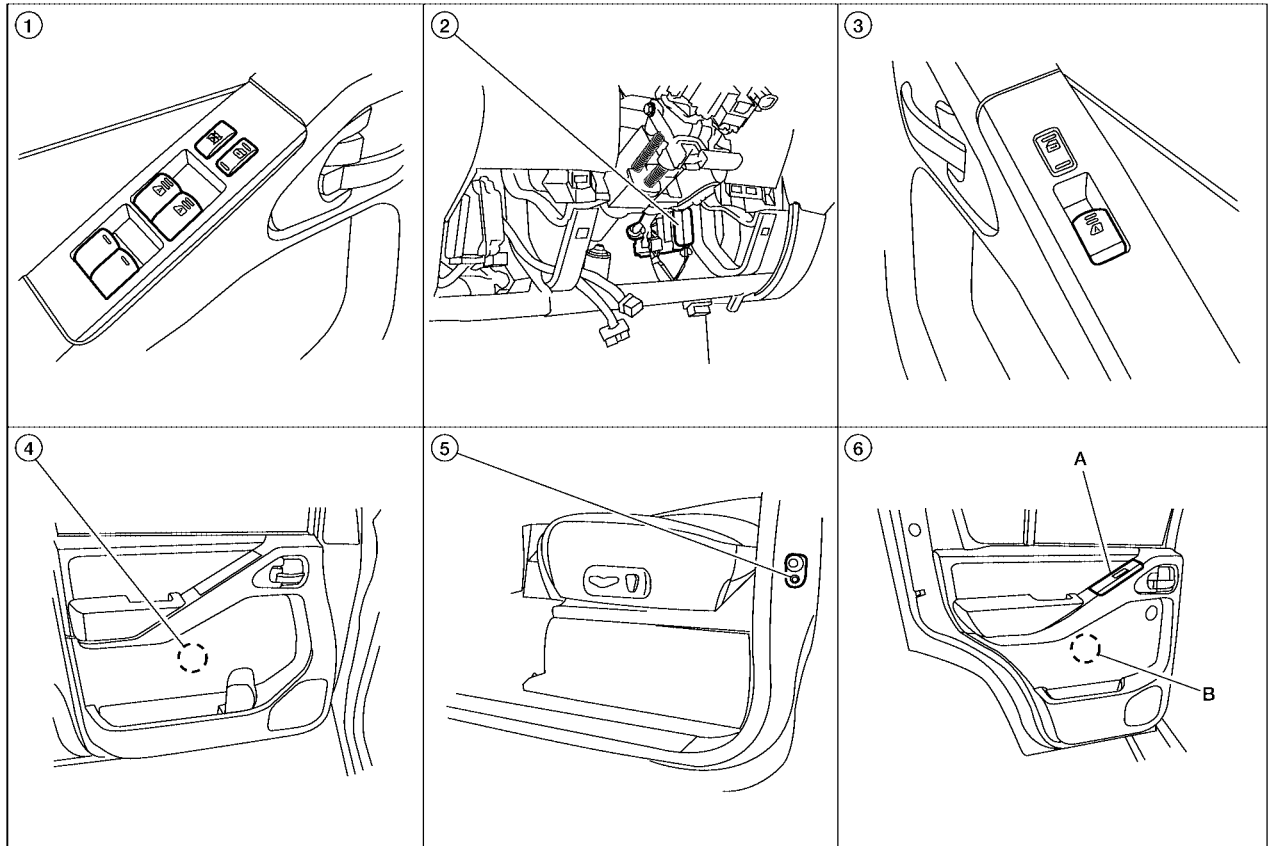

1. Main power window and door lock/unlock switch D7, D8
2. BCM M18, M19, M20 (view with instrument lower panel LH removed)
3. Power window and door lock/unlock switch RH D105
4. Front power window motor LH D9, RH D104
5. Front door switch LH B8, RH B108
6. A. Rear power window switch LH D203, RH D303
B. Rear power window motor LH D204, RH D304

LIA2390E

System Description

EIS007RC

Power is supplied at all times

- from 50A fusible link (letter **g**, located in the fuse and fusible link box)
- to BCM terminal 70

With ignition switch in ON or START position, power is supplied

- through 10A fuse [No. 1, located in the fuse block (J/B)]
- to BCM terminal 38
- through BCM terminal 68
- to main power window and door lock/unlock switch terminal 10
- to power window and door lock/unlock switch RH terminal 8
- to rear power window switches LH and RH terminal 8.

Ground is supplied

- to BCM terminal 67
- to main power window and door lock/unlock switch terminal 17
- to power window and door lock/unlock switch RH terminal 3
- through body grounds M57, M61 and M79.

With ignition switch in ACC or ON position, power is supplied

- through 10A fuse [No. 4, located in the fuse block (J/B)]

A
B
C
D
E
F
G
H
J
K
L
M

GW

POWER WINDOW SYSTEM

- to BCM terminal 11.

MANUAL OPERATION

Front Door LH

WINDOW UP

When the front LH switch in the main power window and door lock/unlock switch is pressed in the up position, power is supplied

- through main power window and door lock/unlock switch terminal 16
- to front power window motor LH terminal 5.

Ground is supplied

- through main power window and door lock/unlock switch terminal 12
- to front power window motor LH terminal 1.

Then, the motor raises the window until the switch is released.

WINDOW DOWN

When the front LH switch in the main power window and door lock/unlock switch is pressed in the down position, power is supplied

- through main power window and door lock/unlock switch terminal 12
- to front power window motor LH terminal 1.

Ground is supplied

- through main power window and door lock/unlock switch terminal 16
- to front power window motor LH terminal 5.

Then, the motor lowers the window until the switch is released.

Front Door RH

POWER WINDOW AND DOOR LOCK/UNLOCK SWITCH RH OPERATION

WINDOW UP

When the power window and door lock/unlock switch RH is pressed in the up position, power is supplied

- through power window and door lock/unlock switch RH terminal 7
- to front power window motor RH terminal 2.

Ground is supplied

- through power window and door lock/unlock switch RH terminal 6
- to front power window motor RH terminal 1.

Then, the motor raises the window until the switch is released.

WINDOW DOWN

When the power window and door lock/unlock switch RH is pressed in the down position, power is supplied

- through power window and door lock/unlock switch RH terminal 6
- to front power window motor RH terminal 1.

Ground is supplied

- through power window and door lock/unlock switch RH terminal 7
- to front power window motor RH terminal 2.

Then, the motor lowers the window until the switch is released.

MAIN POWER WINDOW AND DOOR LOCK/UNLOCK SWITCH OPERATION

WINDOW UP

When the main power window and door lock/unlock switch (front RH) is pressed in the up position, power is supplied

- through main power window and door lock/unlock switch terminal 8
- to power window and door lock/unlock switch RH terminal 12
- through power window and door lock/unlock switch RH terminal 7
- to front power window motor RH terminal 2.

Ground is supplied

- through main power window and door lock/unlock switch terminal 11
- to power window and door lock/unlock switch RH terminal 11
- through power window and door lock/unlock switch LH terminal 6

POWER WINDOW SYSTEM

- to front power window motor RH terminal 1.

Then, the motor raises the window until the switch is released.

WINDOW DOWN

When the main power window and door lock/unlock switch (front RH) is pressed in the down position, power is supplied

- through main power window and door lock/unlock switch terminal 11
- to power window and door lock/unlock switch LH terminal 11
- through power window and door lock/unlock switch LH terminal 6
- to front power window motor RH terminal 1.

Ground is supplied

- through main power window and door lock/unlock switch terminal 8
- to power window and door lock/unlock switch RH terminal 12
- through power window and door lock/unlock switch LH terminal 7
- to front power window motor RH terminal 2.

Then, the motor lowers the window until the switch is released.

Rear Door (LH or RH)

REAR POWER WINDOW SWITCH LH OR RH OPERATION

WINDOW UP

When the rear power window switch LH or RH is pressed in the up position, power is supplied

- through rear power window switch LH or RH terminal 7
- to rear power window motor LH or RH terminal 2.

Ground is supplied

- through rear power window switch LH or RH terminal 6
- to rear power window motor LH or RH terminal 1.

Then, the motor raises the window until the switch is released.

WINDOW DOWN

When the rear power window switch LH or RH is pressed in the down position, power is supplied

- through rear power window switch LH or RH terminal 6
- to rear power window motor LH or RH terminal 1.

Ground is supplied

- through rear power window switch LH or RH terminal 7
- to rear power window motor LH or RH terminal 2.

Then, the motor lowers the window until the switch is released.

MAIN POWER WINDOW AND DOOR LOCK/UNLOCK SWITCH OPERATION

WINDOW UP

When the main power window and door lock/unlock switch (rear LH) is pressed in the up position, power is supplied

- through main power window and door lock/unlock switch terminal 1
- to rear power window switch LH terminal 4
- through rear power window switch LH terminal 7
- to rear power window motor LH terminal 2.

Ground is supplied

- through main power window and door lock/unlock switch terminal 3
- to rear power window switch LH terminal 5
- through rear power window switch LH terminal 6
- to rear power window motor LH terminal 1.

Then, the motor raises the window until the switch is released.

When the main power window and door lock/unlock switch (rear RH) is pressed in the up position, power is supplied

- through main power window and door lock/unlock switch terminal 7
- to rear power window switch RH terminal 4

A
B
C
D
E
F
G
H
J
K
L
M

GW

POWER WINDOW SYSTEM

- through rear power window switch RH terminal 7
- to rear power window motor RH terminal 2.

Ground is supplied

- through main power window and door lock/unlock switch terminal 5
- through rear power window switch RH terminal 5
- to rear power window switch RH terminal 6
- to rear power window motor RH terminal 1.

Then, the motor raises the window until the switch is released.

WINDOW DOWN

When the main power window and door lock/unlock switch (rear LH) is pressed in the down position, power is supplied

- through main power window and door lock/unlock switch terminal 3
- to rear power window switch LH terminal 5
- through rear power window switch LH terminal 6
- to rear power window motor LH terminal 1.

Ground is supplied

- through main power window and door lock/unlock switch terminal 1
- to rear power window switch LH terminal 4
- through rear power window switch LH terminal 7
- to rear power window motor LH terminal 2.

Then, the motor lowers the window until the switch is released.

When the main power window and door lock/unlock switch (rear RH) is pressed in the down position, power is supplied

- through main power window and door lock/unlock switch terminal 5
- to rear power window switch RH terminal 5
- through rear power window switch RH terminal 6
- to rear power window motor RH terminal 1.

Ground is supplied

- through main power window and door lock/unlock switch terminal 7
- to rear power window switch RH terminal 4
- through rear power window switch RH terminal 7
- to rear power window motor RH terminal 2.

Then, the motor lowers the window until the switch is released.

AUTO OPERATION

The power window AUTO feature enables the driver to open the window without holding the window switch in the down position.

POWER WINDOW LOCK

The power window lock is designed to lock operation of all windows except for front door window LH.

When in the lock position, the power window lock disables power window and door lock/unlock switch RH and rear power window switch LH and RH by disconnecting switch ground signal. This prevents the power window motors from operating.

RETAINED POWER OPERATION

When the ignition switch is turned to the OFF position from ON or START position, power is supplied for 45 seconds

- through BCM terminal 68
- to main power window and door lock/unlock switch terminal 10
- to power window and door lock/unlock switch RH terminal 8
- to rear power window switches LH and RH terminal 8.

When power and ground are supplied, the BCM continues to be energized, and the power window can be operated.

POWER WINDOW SYSTEM

The retained power operation is canceled when the front LH or front RH door is opened. Retained power operation period can be changed by CONSULT-II. Refer to [GW-27, "CONSULT-II Function \(BCM\)"](#) .

CAN Communication System Description

EIS007RD

Refer to [LAN-25, "CAN COMMUNICATION"](#) .

A

B

C

D

E

F

G

H

GW

J

K

L

M

POWER WINDOW SYSTEM

Schematic

EIS007RE

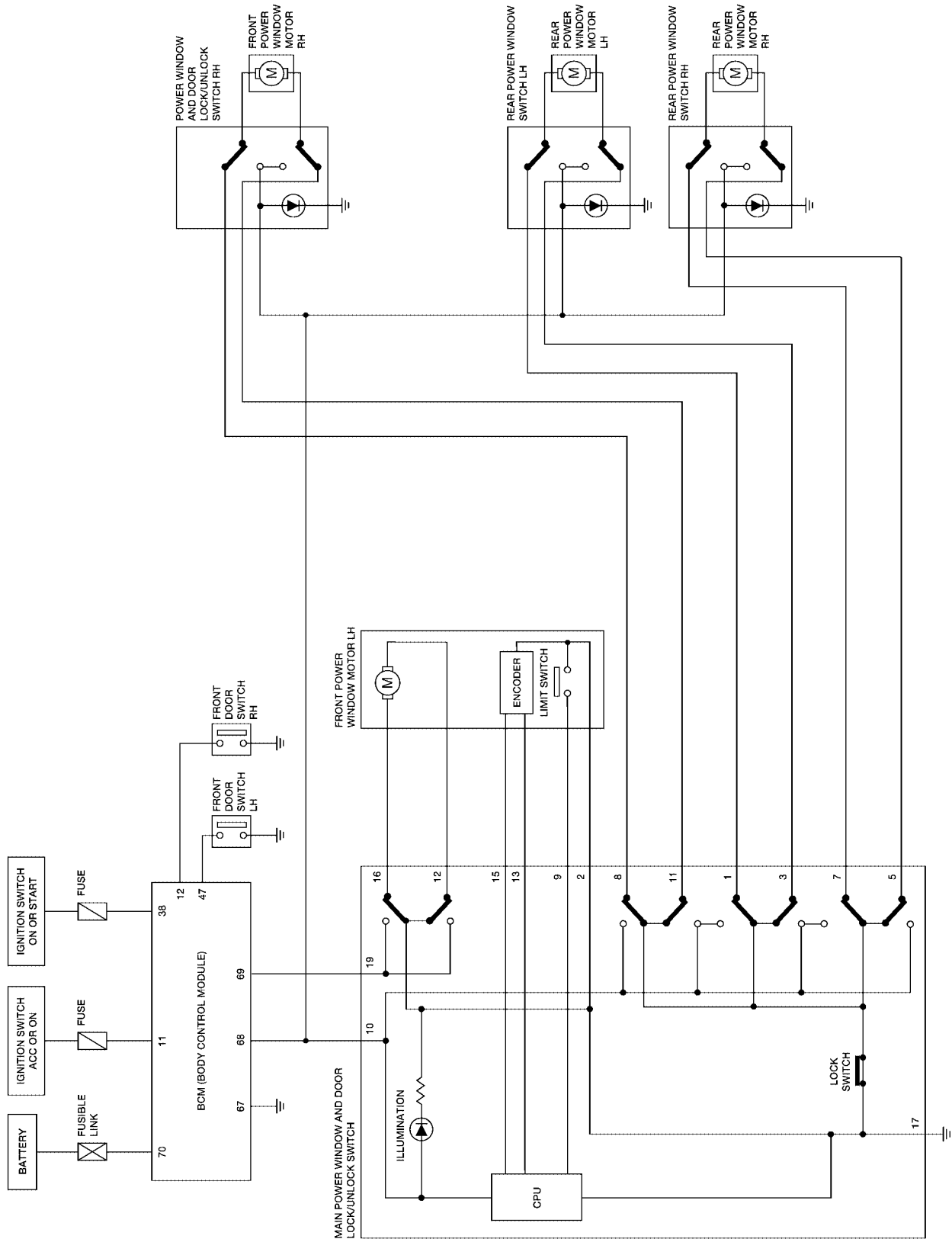

WIWA0524E

POWER WINDOW SYSTEM

Wiring Diagram — WINDOW —

EIS007RF

GW-WINDOW-01

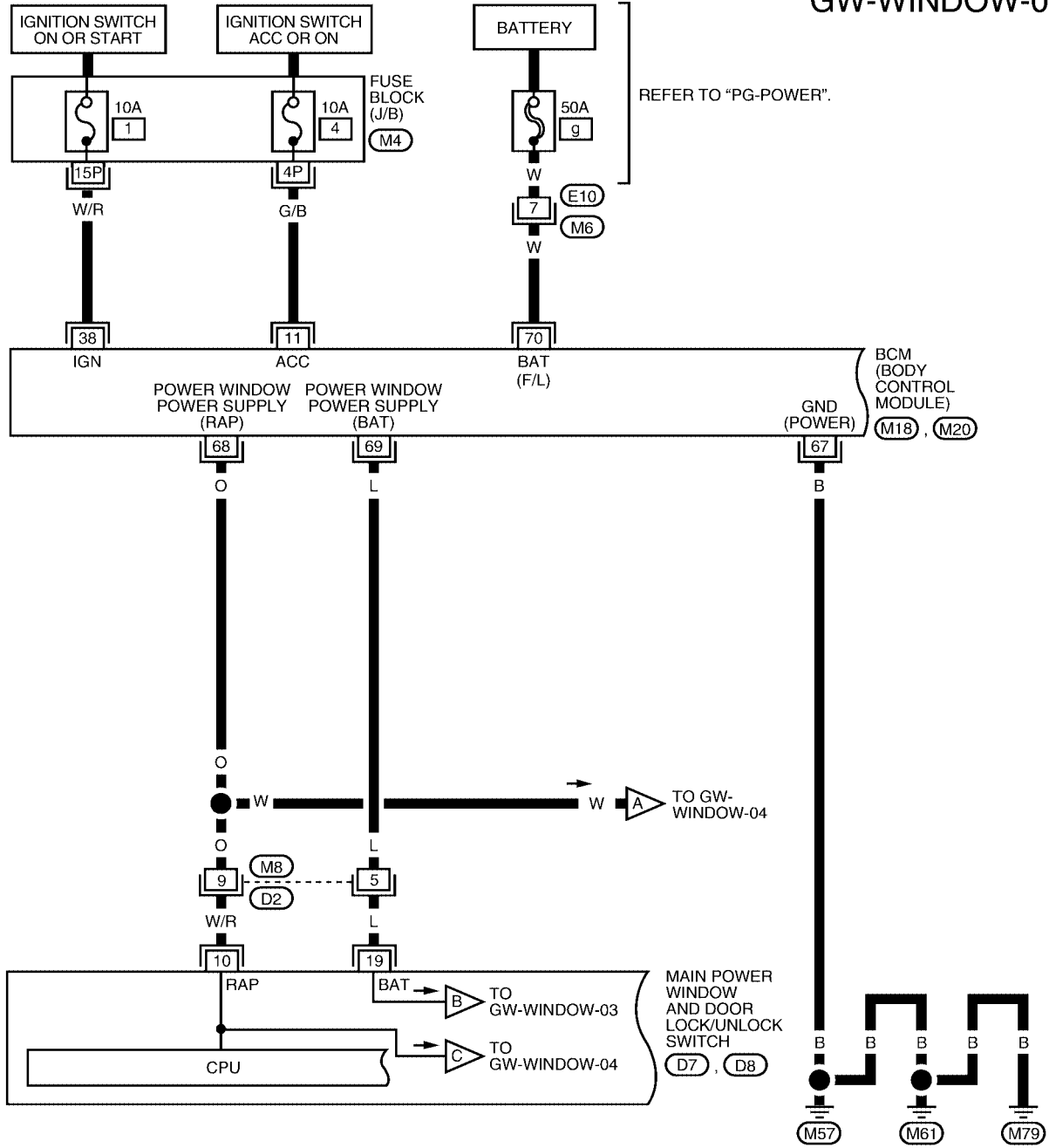

A
B
C
D
E
F
G
H
GW
J
K
L
M

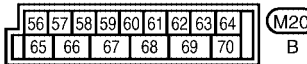
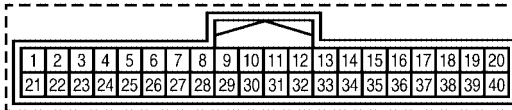
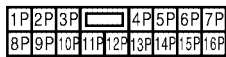

REFER TO THE FOLLOWING.
 (M31) - SUPER MULTIPLE JUNCTION (SMJ)

WIWA1605E

POWER WINDOW SYSTEM

GW-WINDOW-02

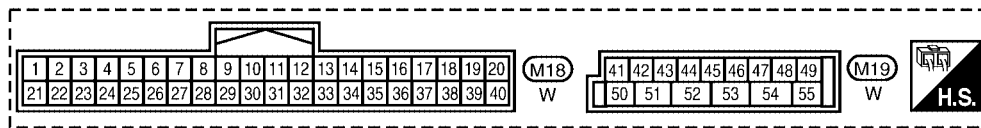
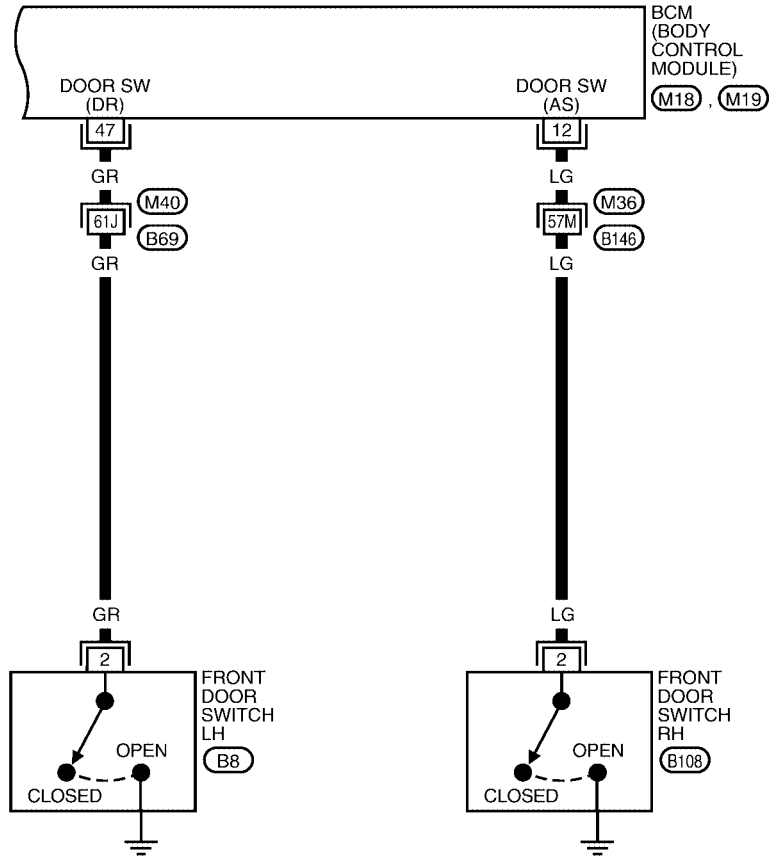

REFER TO THE FOLLOWING.
 (M36), (M40) - SUPER
 MULTIPLE JUNCTION (SMJ)

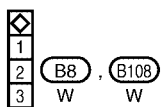

W1WA0737E

POWER WINDOW SYSTEM

GW-WINDOW-03

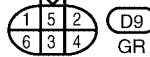
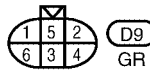
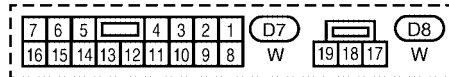
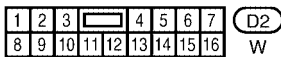
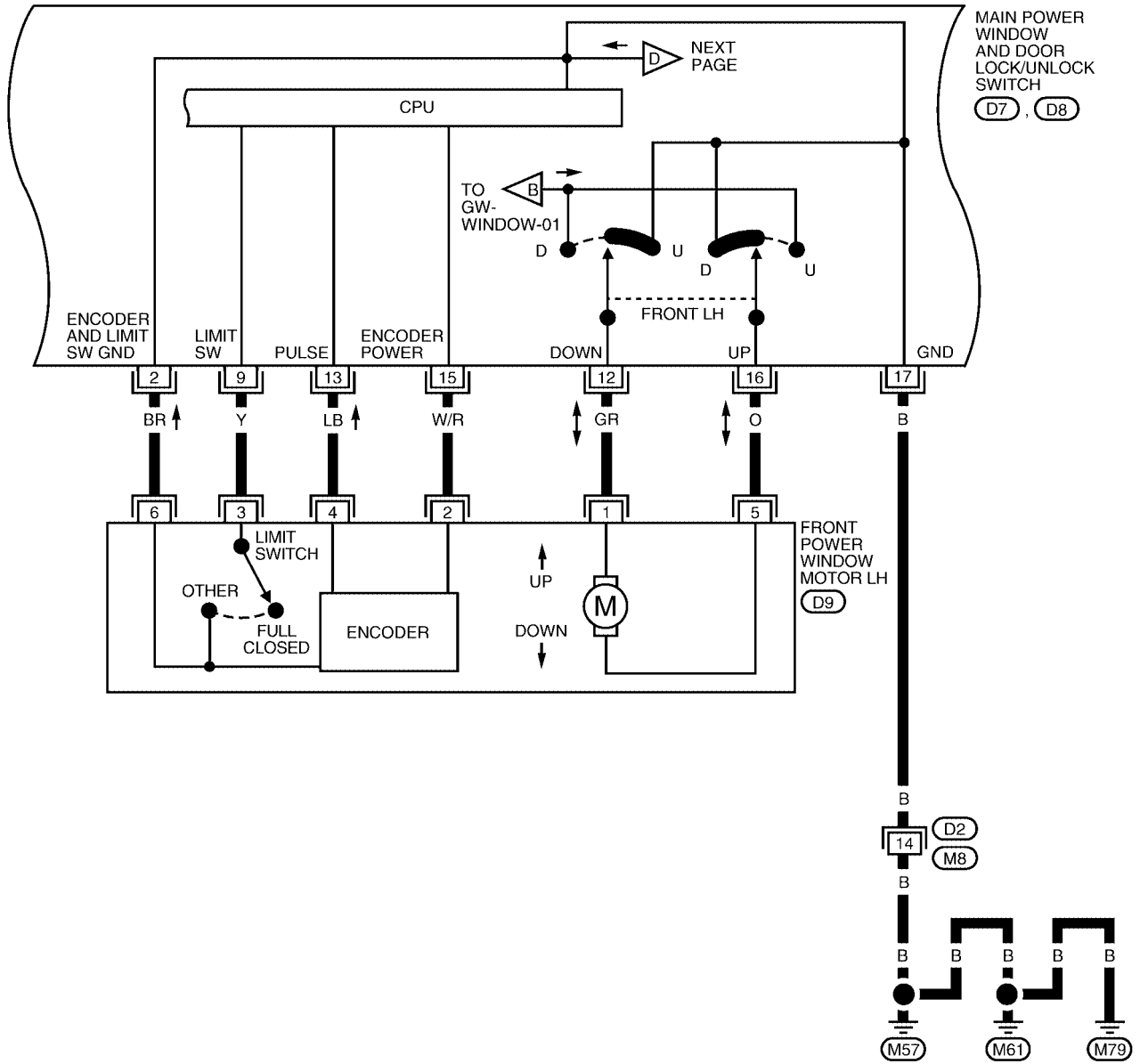

WIWA1037E

POWER WINDOW SYSTEM

GW-WINDOW-04

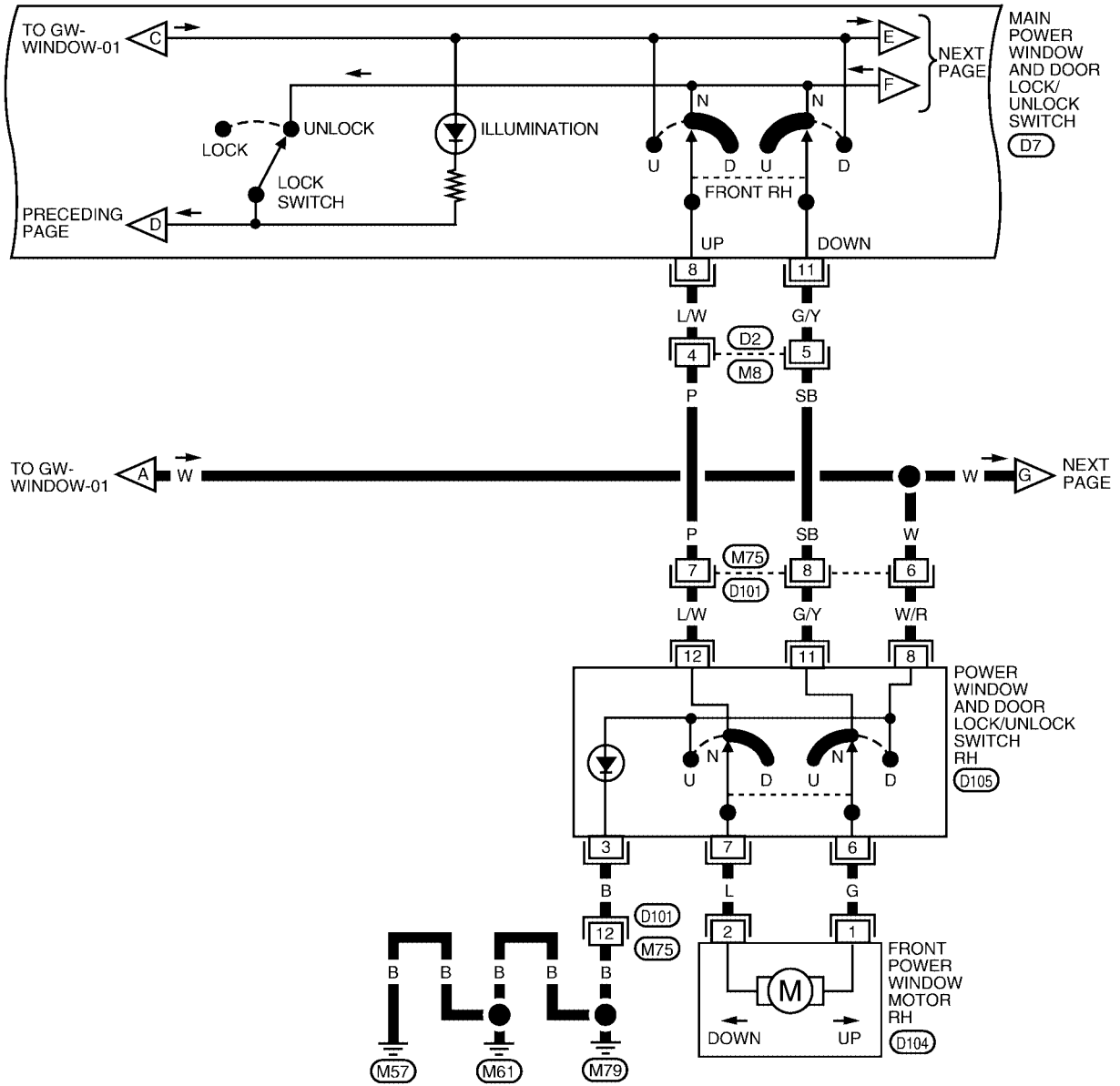

1	2	3	4	5	6	7	(D2)		
8	9	10	11	12	13	14	15	16	W

7	6	5	4	3	2	1	(D7)		
16	15	14	13	12	11	10	9	8	W

1	2	3	4	5	(D101)		
6	7	8	9	10	11	12	W

(D104)	GR
2	1

5	4	3	2	1	(D105)		
12	11	10	9	8	7	6	W

WIWA1038E

POWER WINDOW SYSTEM

GW-WINDOW-05

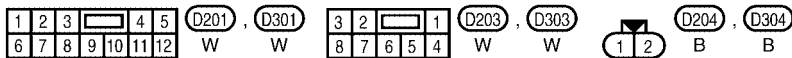
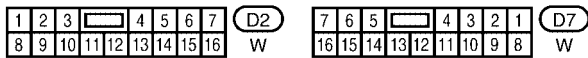
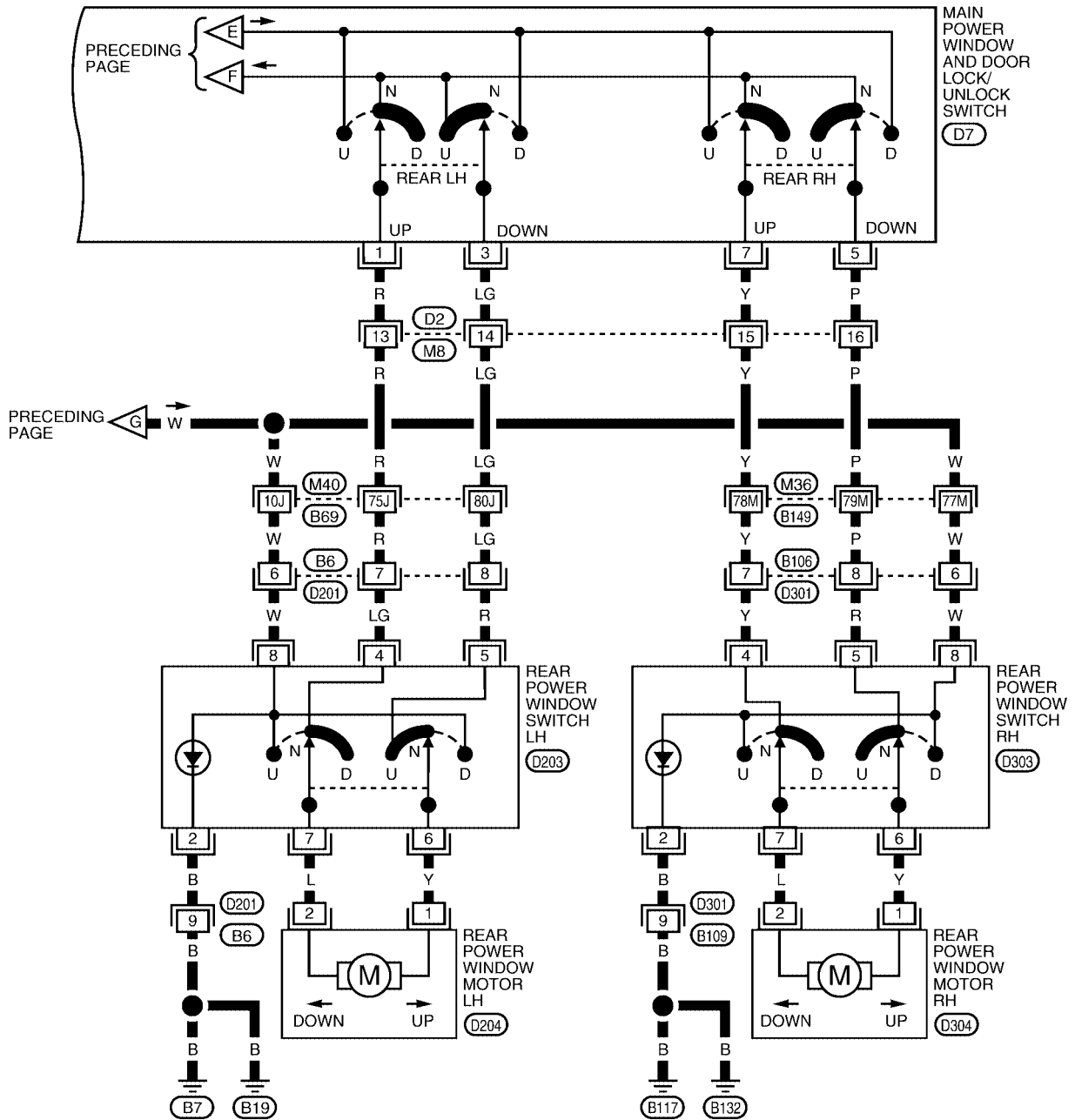

REFER TO THE FOLLOWING.
 (M36), (M40) - SUPER
 MULTIPLE JUNCTION (SMJ)

W1WA1039E

POWER WINDOW SYSTEM

Terminal and Reference Value for Main Power Window and Door Lock/Unlock Switch

EIS007RG

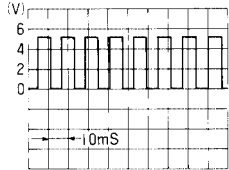
Terminal	Wire Color	Item	Condition	Voltage (V) (Approx.)
1	R	Rear power window LH UP signal	When rear LH switch in main power window and door lock/unlock switch is operated UP	Battery voltage
2	BR	Limit switch and encoder ground	—	0
3	LG	Rear power window LH DOWN signal	When rear LH switch in main power window and door lock/unlock switch is operated DOWN	Battery voltage
5	P	Rear power window RH DOWN signal	When rear RH switch in main power window and door lock/unlock switch is operated DOWN	Battery voltage
7	Y	Rear power window RH UP signal	When rear RH switch in main power window and door lock/unlock switch is operated UP	Battery voltage
8	L/W	Front power window motor RH UP signal	When power window motor is operated UP	Battery voltage
9	Y	Limit switch signal	Front power window LH is between fully-open and just before fully-closed position (ON)	0
			Front power window LH is between just before fully-closed position and fully-closed position (OFF)	5
10	W/R	RAP signal	When ignition switch ON	Battery voltage
			Within 45 seconds after ignition switch is turned to OFF	Battery voltage
			More than 45 seconds after ignition switch is turned to OFF	0
			When front door LH or RH open or power window timer operates	0
11	G/Y	Front power window motor RH DOWN signal	When power window motor is operated DOWN	Battery voltage
12	GR	Front power window motor LH DOWN signal	When power window motor is operated DOWN	Battery voltage
13	LB	Encoder pulse signal	When power window motor operates	 <p style="text-align: right; font-size: small;">OCC3383D</p>
15	W/R	Encoder power supply	When ignition switch ON or power window timer operates	10
16	O	Front power window motor LH UP signal	When power window motor is operated UP	Battery voltage
17	B	Ground	—	0
19	L	Battery power supply	—	Battery voltage

POWER WINDOW SYSTEM

Terminal and Reference Value for BCM

EIS007RH

Refer to [BCS-12, "Terminals and Reference Values for BCM"](#) .

Work Flow

EIS007RI

1. Check the symptom and customer's requests.
2. Understand the outline of system. Refer to [GW-15, "System Description"](#) .
3. According to the trouble diagnosis chart, repair or replace the cause of the malfunction.
Refer to [GW-29, "Trouble Diagnoses Symptom Chart"](#) .
4. Does power window system operate normally? Yes, GO TO 5, If No, GO TO 3.
5. Inspection end.

CONSULT-II Function (BCM)

EIS007RJ

CONSULT-II can display each diagnostic item using the diagnostic test modes shown following.

BCM diagnostic test item	Diagnostic mode	Content
Inspection by part	WORK SUPPORT	Supports inspections and adjustments. Commands are transmitted to the BCM for setting the status suitable for required operation, input/output signals are received from the BCM and received data is displayed.
	DATA MONITOR	Displays BCM input/output data in real time.
	ACTIVE TEST	Operation of electrical loads can be checked by sending drive signal to them.
	SELF-DIAG RESULTS	Displays BCM self-diagnosis results.
	CAN DIAG SUPPORT MNTR	The results of transmit/receive diagnosis of CAN communication can be read.
	ECU PART NUMBER	BCM part number can be read.
	CONFIGURATION	Performs BCM configuration read/write functions.

A
B
C
D
E
F
G
H
J
K
L
M

GW

CONSULT-II INSPECTION PROCEDURE

CAUTION:

If CONSULT-II is used with no connection of CONSULT-II CONVERTER, malfunctions might be detected in self-diagnosis depending on control unit which carries out CAN communication.

1. Connect CONSULT-II and CONSULT-II CONVERTER to the data link connector.
2. Turn ignition switch ON.

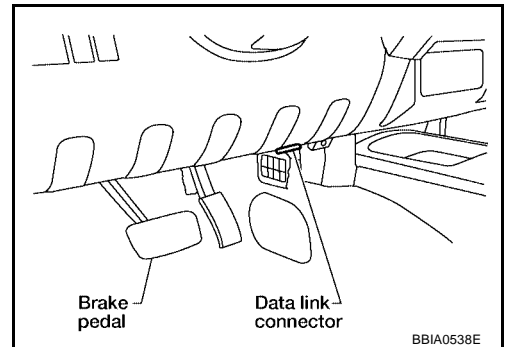

3. Touch "START (NISSAN BASED VHCL)".

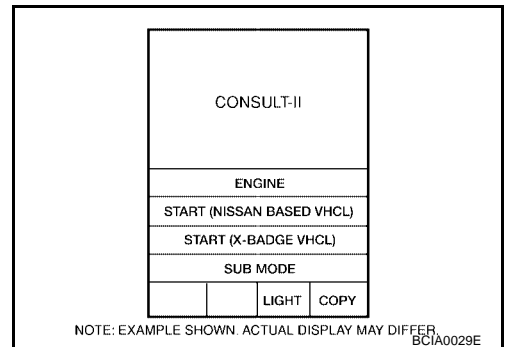

POWER WINDOW SYSTEM

4. Touch "BCM".
If "BCM" is not indicated, refer to [GI-40, "CONSULT-II Data Link Connector \(DLC\) Circuit"](#).

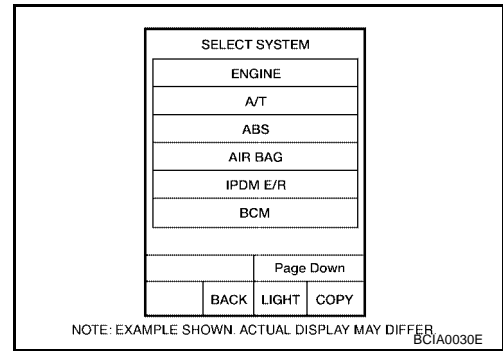

5. Touch "RETAINED PWR".

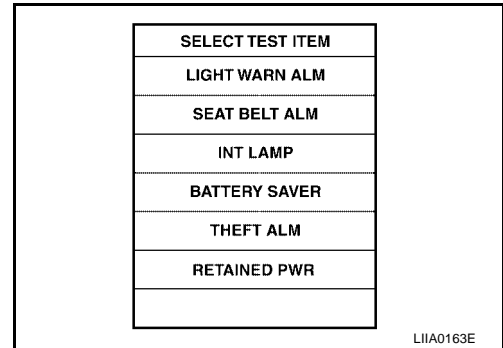

6. Select diagnosis mode.
"ACTIVE TEST", "WORK SUPPORT" and "DATA MONITOR" are available.

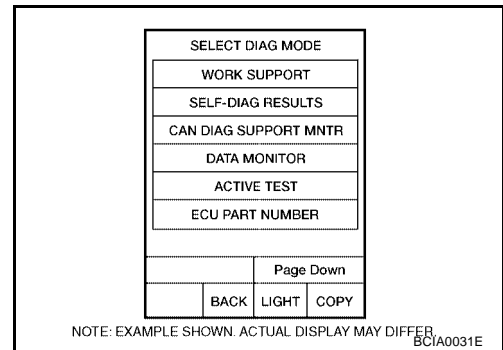

ACTIVE TEST

Test Item	Description
RETAINED PWR	<p>This test is able to supply RAP signal (power) from BCM (body control module) to power window system and power sunroof system (if equipped). Those systems can be operated when turning on "RETAINED PWR" on CONSULT-II screen even if the ignition switch is turned OFF.</p> <p>NOTE: During this test, CONSULT-II can be operated with ignition switch in OFF position. "RETAINED PWR" should be turned "ON" or "OFF" on CONSULT-II screen when ignition switch is ON. Then turn ignition switch OFF to check retained power operation. CONSULT-II might be stuck if "RETAINED PWR" is turned "ON" or "OFF" on CONSULT-II screen when ignition switch is OFF.</p>

WORK SUPPORT

Work item	Description
RETAINED PWR	<p>RAP signal's power supply period can be changed by mode setting. Selects RAP signal's power supply period between three steps</p> <ul style="list-style-type: none"> ● MODE1 (45 sec.)/MODE2 (OFF)/MODE 3 (2 min.).

DATA MONITOR

Work item	Description
IGN ON SW	Indicates (ON/OFF) condition of ignition switch

POWER WINDOW SYSTEM

DOOR SW-DR	Indicates (ON/OFF) condition of front door switch driver side
DOOR SW-AS	Indicates (ON/OFF) condition of front door switch passenger side

Trouble Diagnoses Symptom Chart

EIS007RK

- Check that other systems using the signal of the following systems operate normally.

Symptom	Repair order	Refer to page
None of the power windows can be operated using any switch	1. BCM power supply and ground circuit check	GW-29
	2. Main power window and door lock/unlock power supply and ground circuit check	GW-30
	3. Replace main power window and door lock/unlock switch	EI-25
Front power window LH alone does not operate	1. Front power window motor LH circuit check	GW-31
	2. Replace main power window and door lock/unlock switch	EI-25
Front power window RH alone does not operate from power window and door lock/unlock switch RH	1. Front power window RH circuit check (power window and door lock/unlock switch operation)	GW-32
Front power window RH alone does not operate from main power window and door lock/unlock switch	1. Main power window and door lock/unlock power supply and ground circuit check	GW-30
	2. Front power window RH circuit check (main power window and door lock/unlock switch operation)	GW-32
Anti-pinch system does not operate normally (Front LH)	1. Door window sliding part malfunction <ul style="list-style-type: none"> ● A foreign material adheres to window glass or glass run rubber. ● Glass run rubber wear or deformation. ● Sash is tilted too much, or not enough. 	—
	2. Limit switch adjusting	GW-60
	3. Limit switch circuit check front LH	GW-38
	4. Encoder circuit check front LH	GW-40
Rear power window LH alone does not operate from rear power window switch LH	1. Rear power window LH circuit check (rear power window switch LH operation)	GW-44
Rear power window LH alone does not operate from main power window and door lock/unlock switch	1. Rear power window LH circuit check (main power window and door lock/unlock switch operation)	GW-48
Rear power window RH alone does not operate from rear power window switch RH	1. Rear power window RH circuit check (rear power window switch RH operation)	GW-50
Rear power window RH alone does not operate from main power window and door lock/unlock switch	1. Rear power window RH circuit check (main power window and door lock/unlock switch operation)	GW-53
Power window retained power operation does not operate properly	1. Check the retained power operation mode setting.	GW-28
	2. Door switch check	GW-43
	3. Replace BCM.	BCS-27

BCM Power Supply and Ground Circuit Check

EIS007RL

Refer to [BCS-16, "BCM Power Supply and Ground Circuit Check"](#).

POWER WINDOW SYSTEM

EIS007RM

Main Power Window and Door Lock/Unlock Switch Power Supply and Ground Circuit Check

1. CHECK POWER SUPPLY CIRCUIT

1. Turn ignition switch ON.
2. Check voltage between main power window and door lock/unlock switch connector D7 terminal 10, D8 terminal 19 and ground.

10 - Ground : Battery voltage
19 - Ground : Battery voltage

OK or NG

- OK >> GO TO 2.
 NG >> GO TO 3.

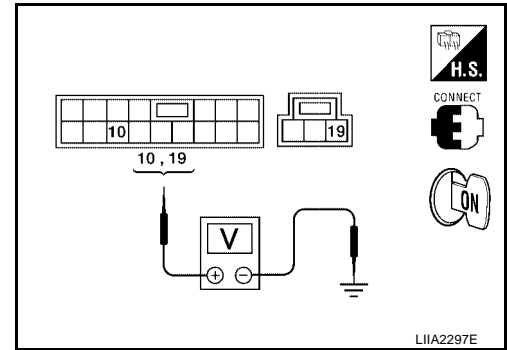

2. CHECK GROUND CIRCUIT

1. Turn ignition switch OFF.
2. Disconnect main power window and door lock/unlock switch.
3. Check continuity between main power window and door lock/unlock switch connector D8 terminal 17 and ground.

17 - Ground : Continuity should exist.

OK or NG

- OK >> Power supply and ground circuit are OK.
 NG >> Repair or replace harness.

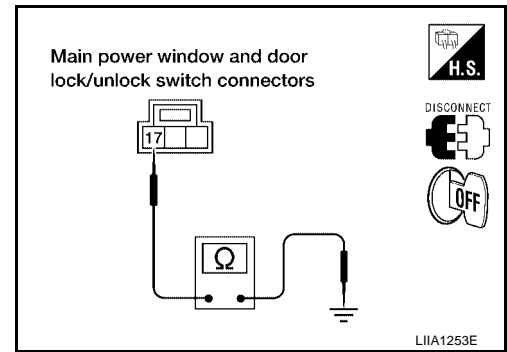

3. CHECK MAIN POWER WINDOW AND DOOR LOCK/UNLOCK SWITCH POWER SUPPLY CIRCUIT

1. Turn ignition switch OFF.
2. Disconnect BCM and main power window and door lock/unlock switch.
3. Check continuity between BCM connector and main power window and door lock/unlock switch connectors.

Connector	Terminal	Connector	Terminal	Continuity
A		B		
BCM: M20	68	Main power window and door lock/unlock switch: D7	10	Yes
	69	Main power window and door lock/unlock switch: D8	19	Yes

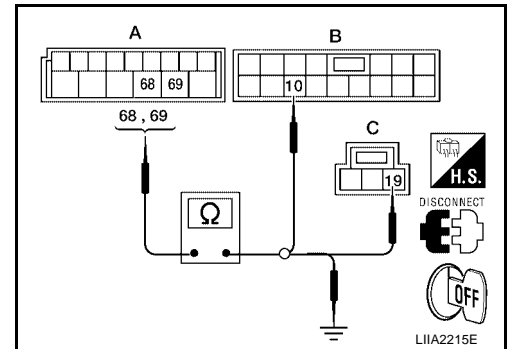

4. Check continuity between BCM and ground.

Connector	Terminal	Ground	Continuity
A			
BCM: M20	68	Ground	No
	69		No

OK or NG

- OK >> GO TO 4.
 NG >> Repair or replace harness.

POWER WINDOW SYSTEM

4. CHECK BCM OUTPUT SIGNAL

1. Connect BCM.
2. Turn ignition switch ON.
3. Check voltage between BCM connector M20 terminals 68, 69 and ground.

68 - Ground : Battery voltage
69 - Ground : Battery voltage

OK or NG

- OK >> Check the condition of the harness and the connector.
 NG >> Replace BCM. Refer to [BCS-27, "Removal and Installation"](#) .

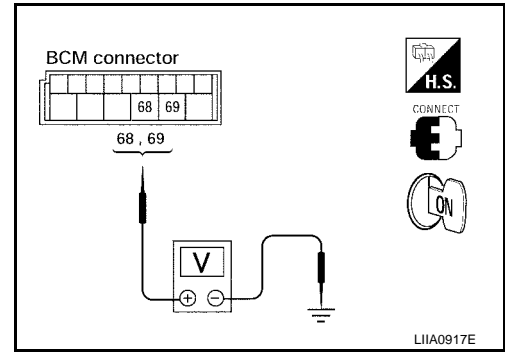

Front Power Window Motor LH Circuit Check

EIS007RO

1. CHECK MAIN POWER WINDOW AND DOOR LOCK/UNLOCK SWITCH OUTPUT SIGNAL

1. Turn ignition switch ON.
2. Check voltage between main power window and door lock/unlock switch connector D7 terminals 12, 16 and ground.

Connector	Terminals		Condition	Voltage (V) (Approx.)
	(+)	(-)		
D7	12	Ground	UP	0
			DOWN	Battery voltage
	16		UP	Battery voltage
			DOWN	0

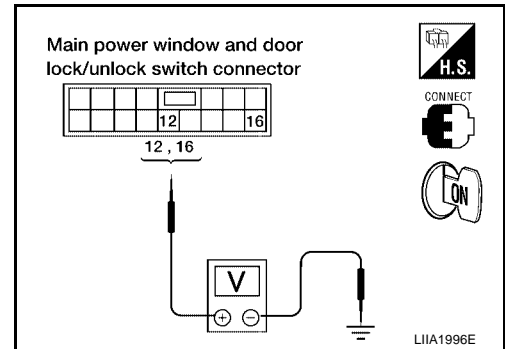

OK or NG

- OK >> GO TO 2.
 NG >> Replace main power window and door lock/unlock switch. Refer to [EI-25, "FRONT DOOR"](#) .

2. CHECK POWER WINDOW MOTOR CIRCUIT

1. Turn ignition switch OFF.
2. Disconnect main power window and door lock/unlock switch and front power window motor LH.
3. Check continuity between main power window and door lock/unlock switch connector and front power window motor LH connector.

Connector	Terminal	Connector	Terminal	Continuity
A		B		
Main power window and door lock/unlock switch: D7	12	Front power window motor LH: D9	1	Yes
	16		5	Yes

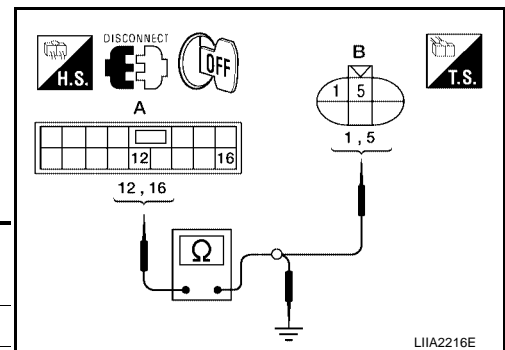

4. Check continuity between main power window and door lock/unlock switch connector and ground.

Connector	Terminal	Ground	Continuity
A			
Main power window and door lock/unlock switch: D7	12		No
	16		No

OK or NG

- OK >> Replace front power window motor LH. Refer to [GW-58, "Front Door Glass Regulator"](#) .
 NG >> Repair or replace harness.

POWER WINDOW SYSTEM

Front Power Window RH Circuit Check (Power Window and Door Lock/Unlock Switch RH Operation)

EIS007RP

1. CHECK POWER WINDOW AND DOOR LOCK/UNLOCK SWITCH RH OUTPUT SIGNAL

1. Turn ignition switch OFF.
2. Disconnect front power window motor RH.
3. Turn ignition switch ON.
4. Check voltage between front power window motor RH connector and ground.

Connector	Terminals		Condition	Voltage (V) (Approx.)
	(+)	(-)		
Front power window motor RH: D104	1	Ground	UP	0
			DOWN	Battery voltage
	2		UP	Battery voltage
			DOWN	0

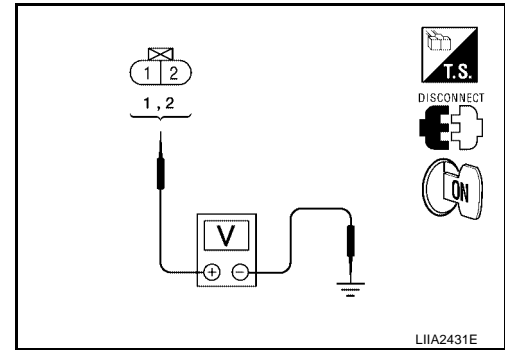

OK or NG

- OK >> Replace front power window motor RH. Refer to [GW-58, "Front Door Glass Regulator"](#) .
 NG >> GO TO 2.

2. CHECK POWER SUPPLY CIRCUIT

1. Turn ignition switch ON.
2. Check voltage between power window and door lock/unlock switch RH connector D105 terminal 8 and ground.

8 - Ground : Battery voltage

OK or NG

- OK >> GO TO 4.
 NG >> GO TO 3.

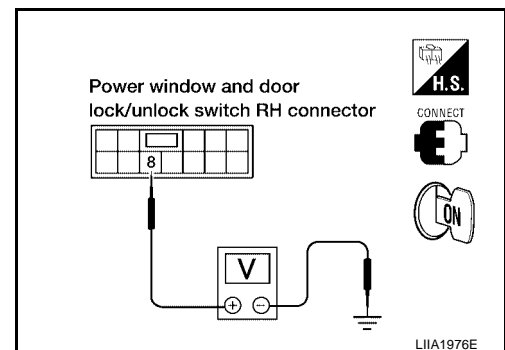

3. CHECK POWER WINDOW AND DOOR LOCK/UNLOCK SWITCH RH POWER SUPPLY CIRCUIT

1. Turn ignition switch OFF.
2. Disconnect BCM and power window and door lock/unlock switch RH.
3. Check continuity between BCM connector and power window and door lock/unlock switch RH connector.

Connector	Terminal	Connector	Terminal	Continuity
A		B		
BCM: M20	68	Power window and door lock/unlock switch RH: D105	8	Yes

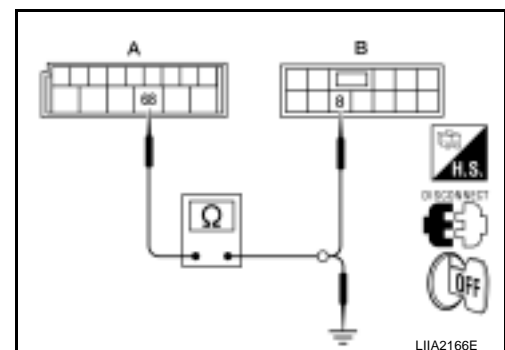

4. Check continuity between BCM and ground.

Connector	Terminal	Ground	Continuity
A			
BCM: M20	68		No

OK or NG

- OK >> Check the condition of the harness and the connector.
 NG >> Repair or replace harness.

POWER WINDOW SYSTEM

4. CHECK POWER WINDOW AND DOOR LOCK/UNLOCK SWITCH RH OUTPUT SIGNAL

1. Turn ignition switch ON.
2. Check voltage between power window and door lock/unlock switch RH connector D105 terminals 6, 7 and ground.

Connector	Terminals		Condition	Voltage (V) (Approx.)
	(+)	(-)		
D105	7	Ground	UP	Battery voltage
			DOWN	0
	6		UP	0
			DOWN	Battery voltage

OK or NG

- OK >> GO TO 5.
 NG >> GO TO 6.

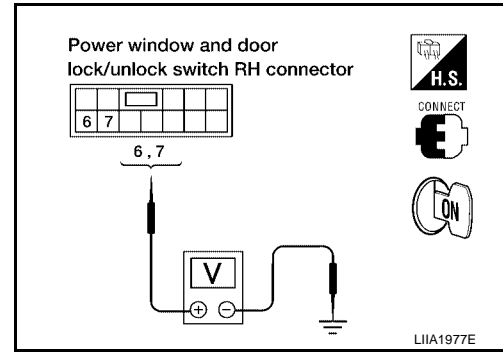

5. CHECK FRONT POWER WINDOW MOTOR RH CIRCUIT

1. Turn ignition switch OFF.
2. Disconnect front power window motor RH and power window and door lock/unlock switch RH.
3. Check continuity between power window and door lock/unlock switch RH connector D105 terminals 6, 7 and front power window motor RH connector D104 terminals 1, 2.

- 7 - 2 : Continuity should exist.**
6 - 1 : Continuity should exist.

4. Check continuity between power window and door lock/unlock switch RH connector D105 terminals 6, 7 and ground.

- 6 - Ground : Continuity should not exist.**
7 - Ground : Continuity should not exist.

OK or NG

- OK >> Replace front power window motor RH. Refer to [GW-58, "Front Door Glass Regulator"](#).
 NG >> Repair or replace harness.

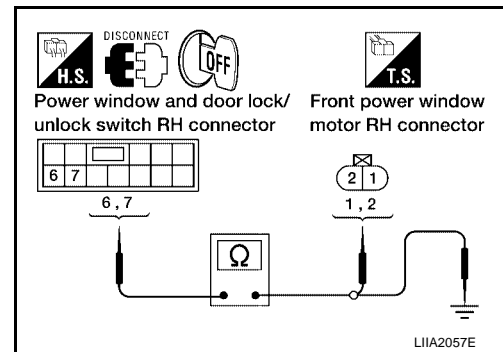

POWER WINDOW SYSTEM

6. CHECK POWER WINDOW AND DOOR LOCK/UNLOCK SWITCH RH

1. Turn ignition switch OFF.
2. Check continuity between power window and door lock/unlock switch RH terminals.

	Terminals		Condition	Continuity
	Power window and door lock/unlock switch RH	6	8	DOWN
NEUTRAL or UP				No
11		NEUTRAL or UP	Yes	
		DOWN	No	
7		8	UP	Yes
			NEUTRAL or DOWN	No
	12	NEUTRAL or DOWN	Yes	
		UP	No	

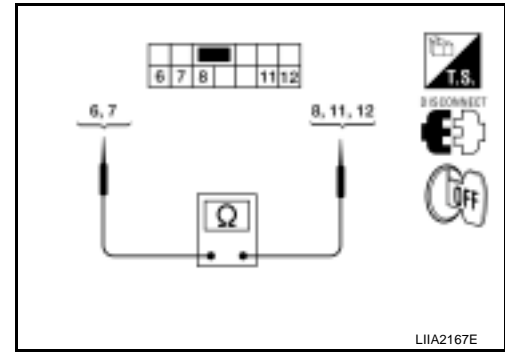

OK or NG

OK >> GO TO 7.

NG >> Replace power window and door lock/unlock switch RH. Refer to [EI-25, "FRONT DOOR"](#).

7. CHECK POWER WINDOW AND DOOR LOCK/UNLOCK SWITCH RH GROUND SUPPLY

Check continuity between power window and door lock/unlock switch RH and ground.

Connector	Terminals	Continuity
Power window and door lock/unlock switch: D105	11	Yes
	12	Yes

OK or NG

OK >> Check the condition of the harness and the connector.

NG >> GO TO 8.

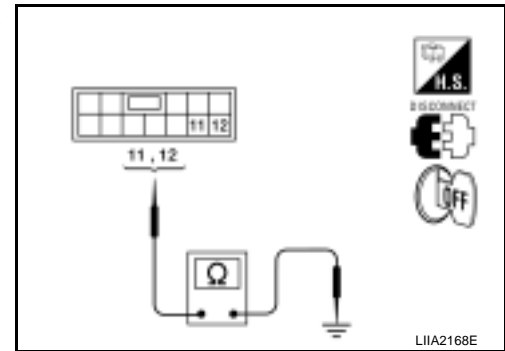

POWER WINDOW SYSTEM

8. CHECK GROUND SUPPLY CIRCUIT

1. Disconnect main power window and door lock/unlock switch and power window and door lock/unlock switch RH.
2. Check continuity between main power window and door lock/unlock switch connector and power window and door lock/unlock switch RH connector.

Connector	Terminal	Connector	Terminal	Continuity
A		B		
Main power window and door lock/unlock switch: D7	8	Power window and door lock/unlock switch RH: D105	12	Yes
	11		11	Yes

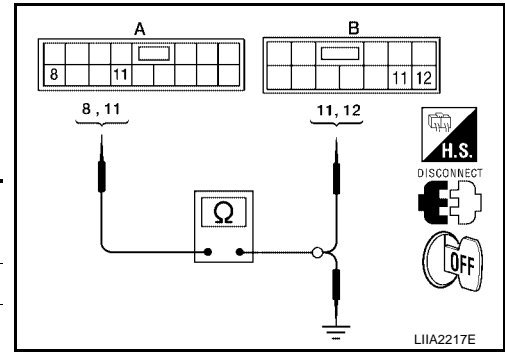

3. Check continuity between main power window and door lock/unlock switch connector and ground.

Connector	Terminal	Ground	Continuity
A			
Main power window and door lock/unlock switch: D7	8	Ground	No
	11		No

OK or NG

OK >> GO TO 9.

NG >> Repair or replace harness.

9. CHECK MAIN POWER WINDOW AND DOOR LOCK/UNLOCK SWITCH

Check continuity between main power window and door lock/unlock switch terminals.

	Terminals		Condition	Continuity
	Main power window and door lock/unlock switch	17	8	Lock switch UNLOCK
Lock switch LOCK				No
11		Lock switch UNLOCK	Yes	
		Lock switch LOCK	No	

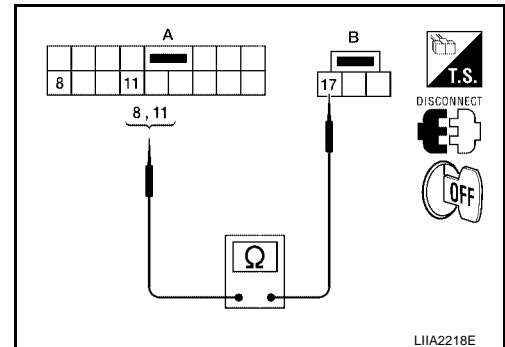

OK or NG

OK >> Repair or replace harness.

NG >> Replace main power window and door lock/unlock switch. Refer to [EI-25, "FRONT DOOR"](#).

A
B
C
D
E
F
G
H
GW
J
K
L
M

POWER WINDOW SYSTEM

Front Power Window RH Circuit Check (Main Power Window and Door Lock/Unlock Switch Operation)

EIS007RQ

1. CHECK MAIN POWER WINDOW AND DOOR LOCK/UNLOCK SWITCH OUTPUT SIGNAL

1. Turn ignition switch OFF.
2. Disconnect front power window motor RH.
3. Turn ignition switch ON.
4. Check voltage between front power window motor RH connector and ground.

Connector	Terminals		Condition	Voltage (V) (Approx.)
	(+)	(-)		
Front power window motor RH: D104	1	Ground	UP	0
			DOWN	Battery voltage
	2		UP	Battery voltage
			DOWN	0

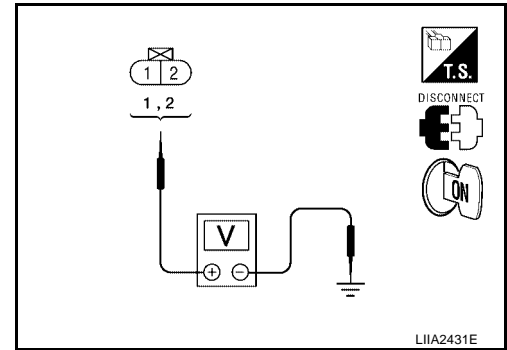

OK or NG

- OK >> Replace front power window motor RH. Refer to [GW-58, "Front Door Glass Regulator"](#) .
 NG >> GO TO 2.

2. CHECK FRONT POWER WINDOW MOTOR RH CIRCUIT

1. Turn ignition switch OFF.
2. Disconnect front power window motor RH and power window and door lock/unlock switch RH.
3. Check continuity between power window and door lock/unlock switch RH connector D105 terminals 6, 7 and front power window motor RH connector D104 terminals 1, 2.

7 - 2 : Continuity should exist.
6 - 1 : Continuity should exist.

4. Check continuity between power window and door lock/unlock switch RH connector D105 terminals 6, 7 and ground.

6 - Ground : Continuity should not exist.
7 - Ground : Continuity should not exist.

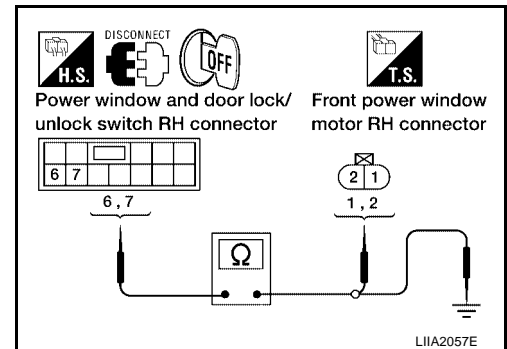

OK or NG

- OK >> GO TO 3.
 NG >> Repair or replace harness.

3. CHECK POWER WINDOW AND DOOR LOCK/UNLOCK SWITCH RH

1. Turn ignition switch OFF.
2. Check continuity between power window and door lock/unlock switch RH terminals.

Power window and door lock/unlock switch	Terminals		Continuity
	6	11	
	7	12	Yes

OK or NG

- OK >> GO TO 4.
 NG >> Replace power window and door lock/unlock switch RH.
 Refer to [EI-25, "FRONT DOOR"](#) .

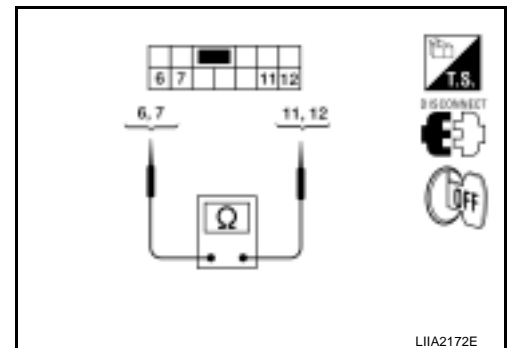

POWER WINDOW SYSTEM

4. CHECK GROUND SUPPLY CIRCUIT

1. Turn ignition switch OFF.
2. Disconnect main power window and door lock/unlock switch and power window and door lock/unlock switch RH.
3. Check continuity between main power window and door lock/unlock switch connector and power window and door lock/unlock switch RH connector.

Connector	Terminal	Connector	Terminal	Continuity
A		B		
Main power window and door lock/unlock switch: D7	8	Power window and door lock/unlock switch RH: D105	12	Yes
	11		11	Yes

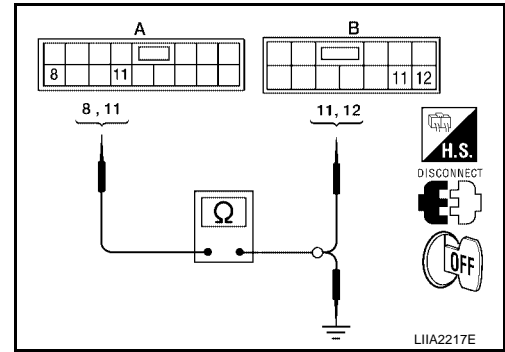

4. Check continuity between main power window and door lock/unlock switch connector and ground.

Connector	Terminal	Ground	Continuity
A			
Main power window and door lock/unlock switch: D7	8	Ground	No
	11		No

OK or NG

- OK >> GO TO 5.
 NG >> Repair or replace harness.

5. CHECK MAIN POWER WINDOW AND DOOR LOCK/UNLOCK SWITCH SIGNAL

1. Connect main power window and door lock/unlock switch.
2. Turn ignition switch ON.
3. Check voltage between main power window and door lock/unlock switch connector and ground.

Connector	Terminals		Condition	Voltage (V) (Approx.)
	(+)	(-)		
Main power window and door lock/unlock switch: D7	8	Ground	UP	Battery voltage
			DOWN	0
	11		UP	0
			DOWN	Battery voltage

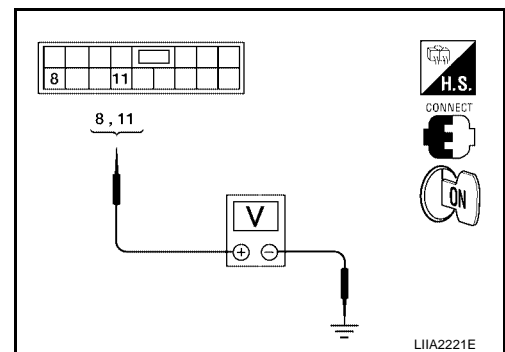

OK or NG

- OK >> Repair or replace harness.
 NG >> Replace main power window and door lock/unlock switch. Refer to [EI-25, "FRONT DOOR"](#).

POWER WINDOW SYSTEM

EIS007RR

Limit Switch Circuit Check Front LH

1. CHECK MAIN POWER WINDOW AND DOOR LOCK/UNLOCK SWITCH LIMIT SIGNAL

1. Turn ignition switch ON.
2. Check voltage between main power window and door lock/unlock switch connector D7 terminal 9 and ground.

Connector	Terminals		Condition	Voltage (V) (Approx.)
	(+)	(-)		
D7	9	Ground	Front door window LH is between fully-open and just before fully-closed position (ON)	0
			Front door window LH is between just before fully-closed position and fully-closed position (OFF)	5

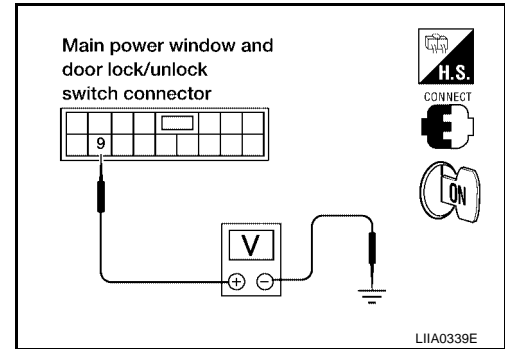

OK or NG

- OK >> Limit switch circuit is OK.
 NG >> GO TO 2.

2. CHECK LIMIT SWITCH GROUND CIRCUIT

1. Turn ignition switch OFF.
2. Disconnect front power window motor LH.
3. Check continuity between front power window motor LH connector D9 terminal 6 and ground.

6 - Ground : Continuity should exist.

OK or NG

- OK >> Replace front power window motor LH. Refer to [GW-58](#), "[Front Door Glass Regulator](#)".
 NG >> GO TO 3.

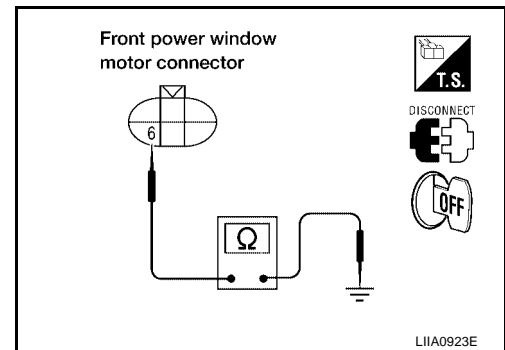

3. CHECK HARNESS CONTINUITY

1. Disconnect main power window and door lock/unlock switch.
2. Check continuity between main power window and door lock/unlock switch connector and front power window motor LH connector.

Connector	Terminal	Connector	Terminal	Continuity
A		B		
Main power window and door lock/unlock switch: D7	2	Front power window motor LH: D9	6	Yes

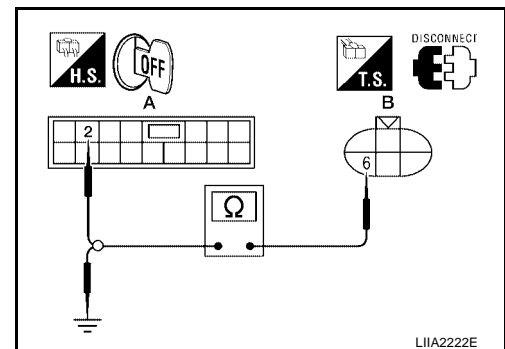

3. Check continuity between front power window motor LH connector and ground.

Connector	Terminal	Ground	Continuity
B			
Front power window motor LH: D9	6	Ground	No

OK or NG

- OK >> GO TO 4.
 NG >> Repair or replace harness.

POWER WINDOW SYSTEM

4. CHECK HARNESS CONTINUITY

1. Check continuity between main power window and door lock/unlock switch connector and front power window motor LH connector.

Connector	Terminal	Connector	Terminal	Continuity
A		B		
Main power window and door lock/unlock switch: D7	9	Front power window motor LH: D9	3	Yes

2. Check continuity between front power window motor LH connector and ground.

Connector	Terminal	Ground	Continuity
B			
Front power window motor LH: D9	3		No

OK or NG

- OK >> GO TO 5.
- NG >> Repair or replace harness.

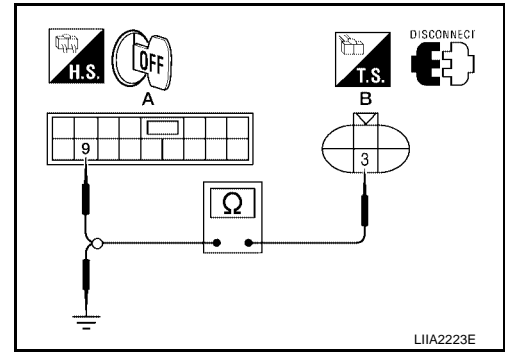

5. CHECK LIMIT SWITCH GROUND

Check continuity between main power window and door lock/unlock switch connector and ground.

Connector	Terminal	Ground	Continuity
Main power window door lock/unlock switch: D7	2		Yes

OK or NG

- OK >> GO TO 7.
- NG >> GO TO 6.

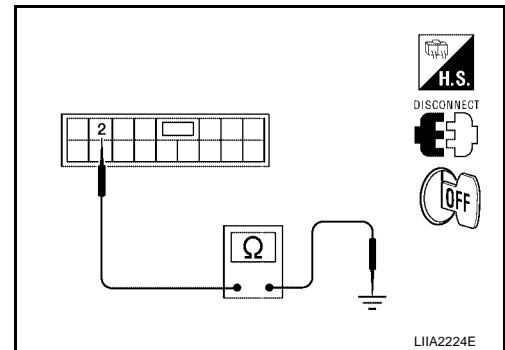

6. CHECK MAIN POWER WINDOW AND DOOR LOCK/UNLOCK SWITCH GROUND CIRCUIT

Check continuity between main power window and door lock/unlock switch connector D8 terminal 17 and ground.

17 - Ground : Continuity should exist.

OK or NG

- OK >> Replace main power window and door lock/unlock switch. Refer to [EI-25, "FRONT DOOR"](#).
- NG >> Repair or replace harness.

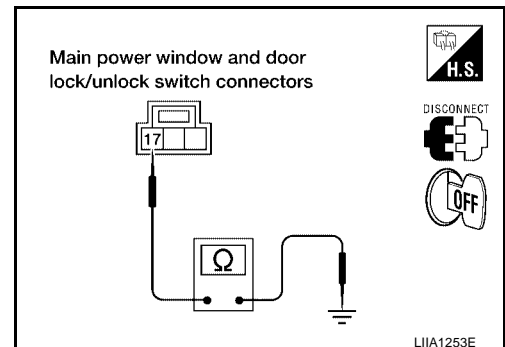

POWER WINDOW SYSTEM

7. CHECK FRONT POWER WINDOW MOTOR LH LIMIT SIGNAL

1. Connect main power window and door lock/unlock switch and front power window motor LH.
2. Turn ignition switch ON.
3. Check voltage between main power window and door lock/unlock switch connector.

Connector	Terminals		Condition	Voltage (V) (Approx.)
	(+)	(-)		
Main power window and door lock/unlock switch: D7	9	2	Front power window LH is between fully-open and just before fully-closed position (ON)	0
			Front power window LH is between just before fully-closed position and fully-closed position (OFF)	5

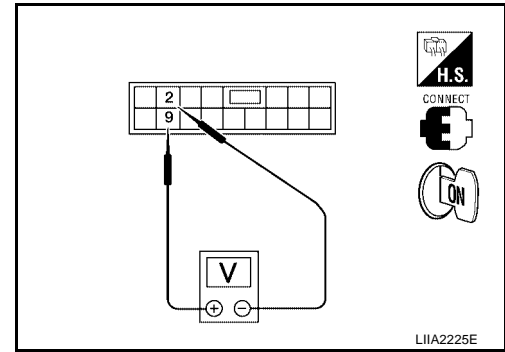

OK or NG

- OK >> Check the condition of the harness and connector.
 NG >> Replace front power window motor LH. Refer to [GW-58, "Front Door Glass Regulator"](#).

Encoder Circuit Check Front LH

EIS007RS

1. CHECK FRONT POWER WINDOW MOTOR LH POWER SUPPLY

1. Turn ignition switch OFF.
2. Disconnect front power window motor LH.
3. Turn ignition switch ON.
4. Check voltage between front power window motor LH connector D9 terminal 2 and ground.

2 - Ground : Approx. 10V

OK or NG

- OK >> GO TO 3.
 NG >> GO TO 2.

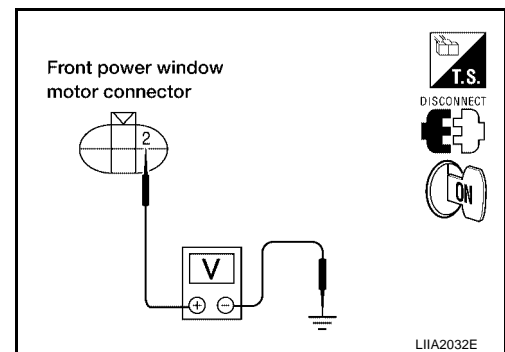

POWER WINDOW SYSTEM

2. CHECK HARNESS CONTINUITY

1. Turn ignition switch OFF.
2. Disconnect main power window and door lock/unlock switch.
3. Check continuity between front power window motor LH connector and main power window and door lock/unlock switch connector.

Connector	Terminal	Connector	Terminal	Continuity
A		B		
Main power window and door lock/unlock switch: D7	15	Front power window motor LH: D9	2	Yes

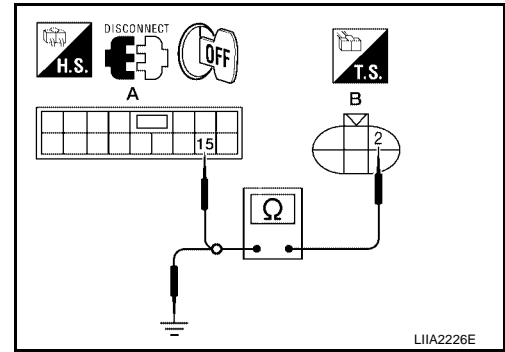

4. Check continuity between front power window motor LH connector and ground.

Connector	Terminal	Ground	Continuity
B			
Front power window motor LH: D9	2	Ground	No

OK or NG

- OK >> Replace main power window and door lock/unlock switch. Refer to [EI-25, "FRONT DOOR"](#).
- NG >> Repair or replace harness.

3. CHECK ENCODER GROUND

1. Turn ignition switch OFF.
2. Check continuity between front power window motor LH connector D9 terminal 6 and ground.

6 - Ground : Continuity should exist.

OK or NG

- OK >> GO TO 5.
- NG >> GO TO 4.

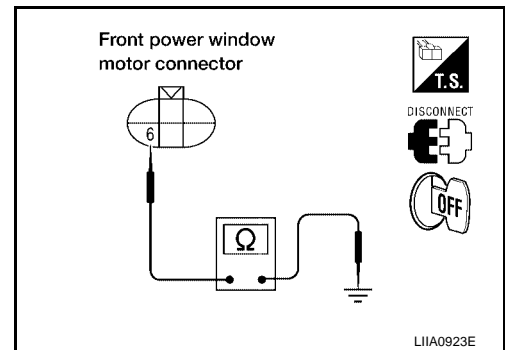

4. CHECK ENCODER GROUND CIRCUIT

1. Disconnect main power window and door lock/unlock switch.
2. Check continuity between front power window motor LH connector D9 terminal 6 and main power window and door lock/unlock switch connector D7 terminal 2.

6 - 2 : Continuity should exist.

OK or NG

- OK >> Replace main power window and door lock/unlock switch. Refer to [EI-25, "FRONT DOOR"](#).
- NG >> Repair or replace harness.

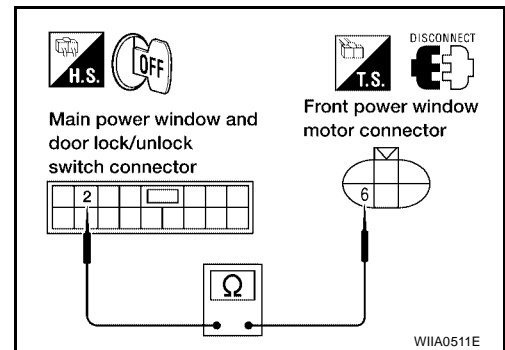

POWER WINDOW SYSTEM

5. CHECK ENCODER SIGNAL

1. Connect front power window motor LH.
2. Turn ignition switch ON.
3. Check the signal between main power window and door lock/unlock switch connector and ground with oscilloscope.

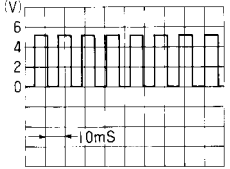
Connector	Terminals		Condition	Signal
	(+)	(-)		
D7	13	Ground	Opening	 <small>OCC3383D</small>

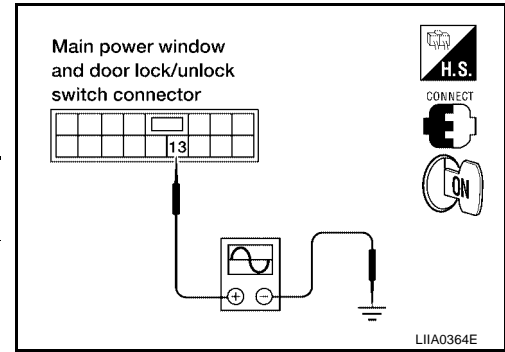

OK or NG

- OK >> Replace main power window and door lock/unlock switch. Refer to [EI-25, "FRONT DOOR"](#) .
- NG >> GO TO 6.

6. CHECK ENCODER CIRCUIT

1. Turn ignition switch OFF.
2. Disconnect front power window motor LH and main power window and door lock/unlock switch.
3. Check continuity between front power window motor LH connector and main power window and door lock/unlock switch connector.

Connector	Terminal	Connector	Terminal	Continuity
A		B		
Main power window and door lock/unlock switch: D7	13	Front power window motor LH: D9	4	Yes

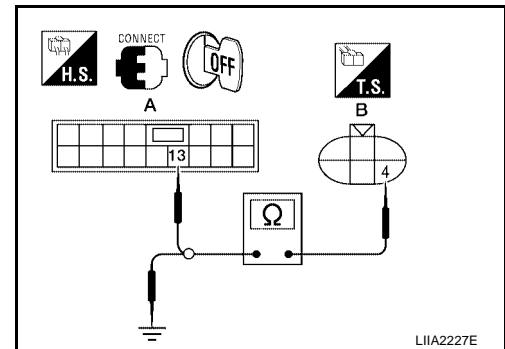

4. Check continuity between front power window motor LH connector and ground.

Connector	Terminal	Ground	Continuity
B			
Front power window motor LH: D9	4	Ground	No

OK or NG

- OK >> Replace front power window motor LH. Refer to [GW-58, "Front Door Glass Regulator"](#) .
- NG >> Repair or replace harness.

POWER WINDOW SYSTEM

EIS007RT

Door Switch Check

1. CHECK FRONT DOOR SWITCH INPUT SIGNAL

With CONSULT-II

Check front door switches (“DOOR SW-DR” and “DOOR SW-AS”) in “DATA MONITOR” mode with CONSULT-II.

Monitor item	Condition
DOOR SW-DR	OPEN: ON
	CLOSE: OFF
DOOR SW-AS	OPEN: ON
	CLOSE: OFF

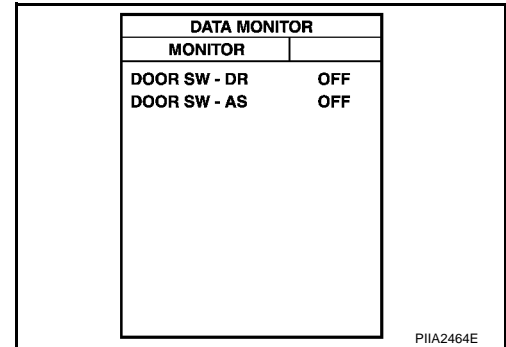

Without CONSULT-II

Check voltage between BCM connector and ground.

Item	Connector	Terminals		Condition	Voltage (V) (Approx.)
		(+)	(-)		
Front RH	M18	12	Ground	OPEN	0
				CLOSE	Battery voltage
Front LH	M19	47		OPEN	0
				CLOSE	Battery voltage

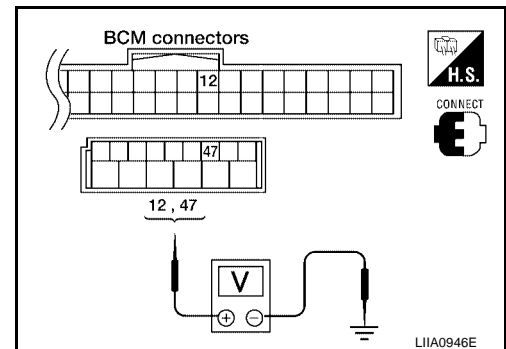

OK or NG

- OK >> Front door switch is OK.
- NG >> GO TO 2.

2. CHECK FRONT DOOR SWITCH CIRCUIT

- Turn ignition switch OFF.
- Disconnect front door switch LH or RH and BCM.
- Check continuity between front door switch connector B8 (LH) or B108 (RH) terminal 2 and BCM connector M19 terminal 47 (LH) or connector M18 terminal 12 (RH).

- Front LH**
- 2 - 47 : Continuity should exist.**
- Front RH**
- 2 - 12 : Continuity should exist.**

- Check continuity between front door switch connector B8 (LH) or B108 (RH) terminal 2 and ground.

- 2 - Ground : Continuity should not exist.**

OK or NG

- OK >> GO TO 3.
- NG >> Repair or replace harness.

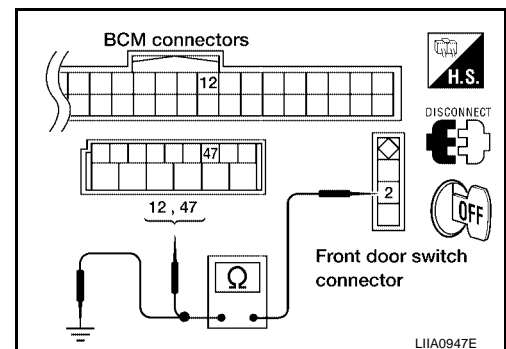

POWER WINDOW SYSTEM

3. CHECK DOOR SWITCH

1. Disconnect front door switch LH or RH.
2. Check continuity between each front door switch terminal 2 and body ground part of front door switch.

Terminal		Door switch	Continuity
2	Body ground part of front door switch	Pushed	No
		Released	Yes

OK or NG

- OK >> Replace BCM. Refer to [BCS-27, "Removal and Installation"](#).
- NG >> Replace malfunctioning front door switch.

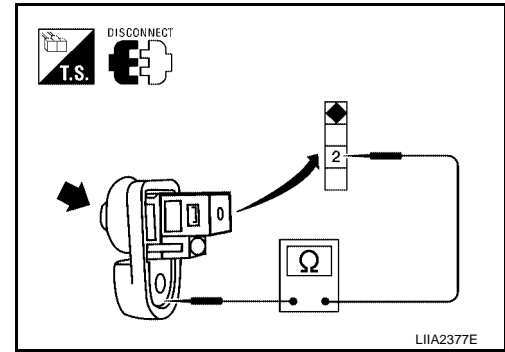

Rear Power Window LH Circuit Check (Rear Power Window Switch LH Operation)

EIS007RU

1. CHECK REAR POWER WINDOW SWITCH LH OUTPUT SIGNAL

1. Turn ignition switch OFF.
2. Disconnect rear power window motor LH.
3. Turn ignition switch ON.
4. Check voltage between rear power window motor LH connector and ground.

Connector	Terminals		Condition	Voltage (V) (Approx.)
	(+)	(-)		
Rear power window motor LH: D204	1	Ground	UP	0
			DOWN	Battery voltage
	2		UP	Battery voltage
			DOWN	0

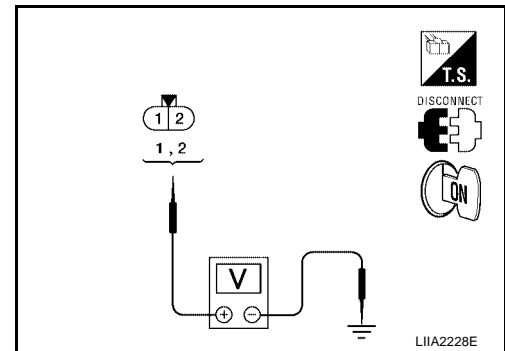

OK or NG

- OK >> Replace rear power window motor LH. Refer to [GW-62, "Rear Door Glass Regulator"](#).
- NG >> GO TO 2.

POWER WINDOW SYSTEM

2. CHECK REAR POWER WINDOW MOTOR LH CIRCUIT

1. Turn ignition switch OFF.
2. Disconnect rear power window switch LH.
3. Check continuity between rear power window switch LH connector and rear power window motor LH connector.

Connector	Terminal	Connector	Terminal	Continuity
A		B		
Rear power window switch LH: D203	6	Rear power window motor LH: D204	1	Yes
	7		2	Yes

4. Check continuity between rear power window switch LH connector and ground.

Connector	Terminal	Ground	Continuity
A			
Rear power window switch LH: D203	6	Ground	No
	7		No

OK or NG

- OK >> GO TO 3.
 NG >> Repair or replace harness.

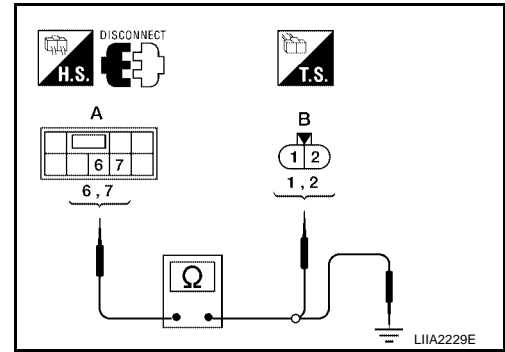

3. CHECK POWER SUPPLY

1. Connect rear power window switch LH.
2. Turn ignition switch ON.
3. Check voltage between rear power window switch LH connector D203 terminal 8 and ground.

8 - Ground : Battery voltage

OK or NG

- OK >> GO TO 4.
 NG >> GO TO 5.

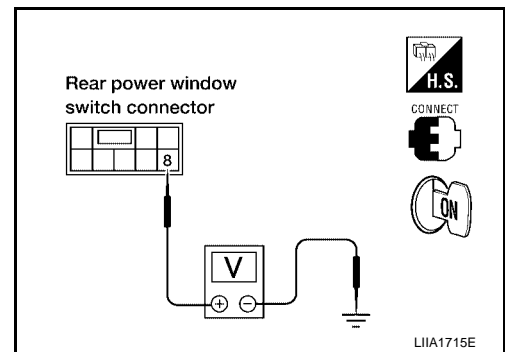

POWER WINDOW SYSTEM

4. CHECK REAR POWER WINDOW SWITCH LH

1. Turn ignition switch OFF.
2. Disconnect rear power window switch LH.
3. Check continuity between rear power window switch LH terminals.

	Terminals		Condition	Continuity
	Rear power window switch LH	6	5	DOWN
NEUTRAL or UP				Yes
8			NEUTRAL or UP	No
			DOWN	Yes
7		4	UP	No
			NEUTRAL or DOWN	Yes
		8	NEUTRAL or DOWN	No
			UP	Yes

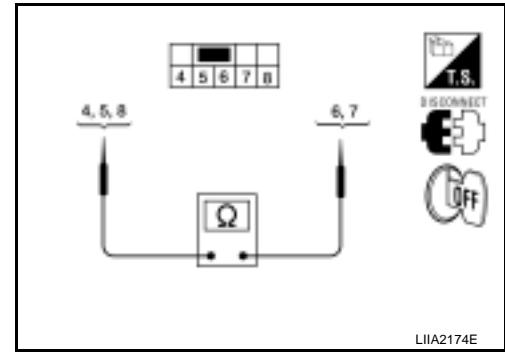

OK or NG

OK >> GO TO 6.

NG >> Replace rear power window switch LH. Refer to [EI-26, "REAR DOOR"](#).

5. CHECK REAR POWER WINDOW SWITCH LH POWER SUPPLY CIRCUIT

1. Turn ignition switch OFF.
2. Disconnect BCM.
3. Check continuity between BCM and rear power window switch LH.

Connector	Terminal	Connector	Terminal	Continuity
A		B		
BCM: M20	68	Rear power window switch LH: D203	8	Yes

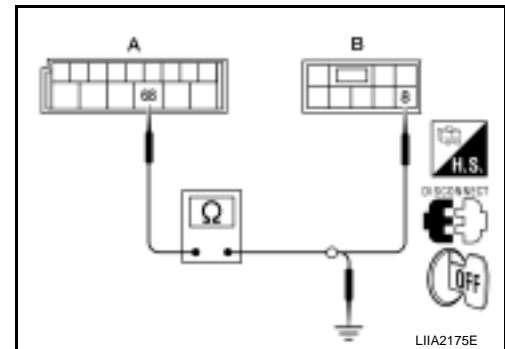

4. Check continuity between BCM and ground.

Connector	Terminal	Ground	Continuity
A			
BCM: M20	68		No

OK or NG

OK >> GO TO 6.

NG >> Repair or replace harness.

POWER WINDOW SYSTEM

6. CHECK REAR POWER WINDOW SWITCH LH GROUND SUPPLY

Check continuity between rear power window switch LH and ground.

Connector	Terminals	Continuity
Rear power window switch LH: D203	4	Yes
	5	Yes

OK or NG

- OK >> Check the condition of the harness and the connector.
- NG >> GO TO 7.

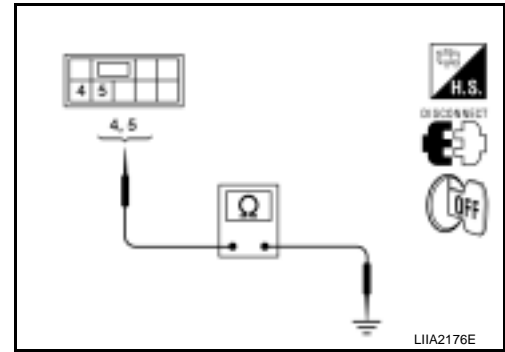

7. CHECK GROUND SUPPLY CIRCUIT

- Disconnect main power window and door lock/unlock switch.
- Check continuity between main power window and door lock/unlock switch connector and rear power window switch LH connector.

Connector	Terminal	Connector	Terminal	Continuity
A		B		
Main power window and door lock/unlock switch: D7	1	Rear power window switch LH: D203	4	Yes
	3		5	Yes

- Check continuity between main power window and door lock/unlock switch connector and ground.

Connector	Terminal	Ground	Continuity
A			
Main power window and door lock/unlock switch: D7	1	Ground	No
	3		No

OK or NG

- OK >> GO TO 8.
- NG >> Repair or replace harness.

8. CHECK MAIN POWER WINDOW AND DOOR LOCK/UNLOCK SWITCH

Check continuity between main power window and door lock/unlock switch terminals.

	Terminals	Condition	Continuity
Main power window and door lock/unlock switch	17	Power window lock switch UNLOCK	Yes
		Power window lock switch LOCK	No
	3	Power window lock switch UNLOCK	Yes
		Power window lock switch LOCK	No

OK or NG

- OK >> Repair or replace harness.
- NG >> Replace main power window and door lock/unlock switch. Refer to [EI-25, "FRONT DOOR"](#).

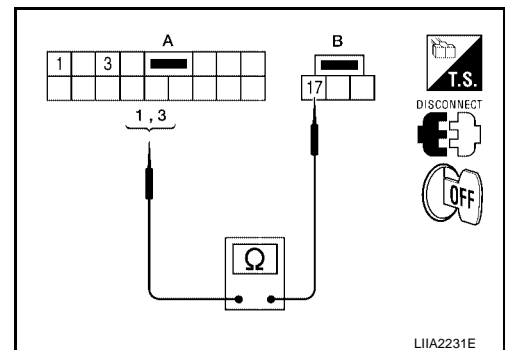

POWER WINDOW SYSTEM

EIS007RV

Rear Power Window LH Circuit Check (Main Power Window and Door Lock/Unlock Switch Operation)

1. CHECK MAIN POWER WINDOW AND DOOR LOCK/UNLOCK SWITCH OUTPUT SIGNAL

1. Turn ignition switch OFF.
2. Disconnect rear power window motor LH.
3. Turn ignition switch ON.
4. Check voltage between rear power window motor LH connector and ground.

Connector	Terminals		Condition	Voltage (V) (Approx.)
	(+)	(-)		
Rear power window motor LH: D204	1	Ground	UP	0
			DOWN	Battery voltage
	2		UP	Battery voltage
			DOWN	0

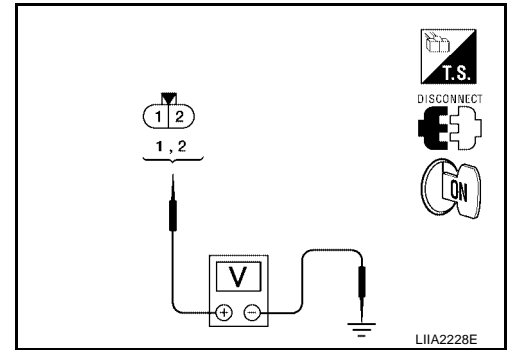

OK or NG

- OK >> Replace rear power window motor LH. Refer to [GW-62, "Rear Door Glass Regulator"](#) .
 NG >> GO TO 2.

2. CHECK REAR POWER WINDOW MOTOR LH CIRCUIT

1. Turn ignition switch OFF.
2. Disconnect rear power window switch LH.
3. Check continuity between rear power window switch LH connector and rear power window motor LH connector.

Connector	Terminal	Connector	Terminal	Continuity
A		B		
Rear power window switch LH: D203	6	Rear power window motor LH: D204	1	Yes
	7		2	Yes

4. Check continuity between rear power window switch LH connector and ground.

Connector	Terminal	Ground	Continuity
A			
Rear power window switch LH: D203	6		No
	7		No

OK or NG

- OK >> GO TO 3.
 NG >> Repair or replace harness.

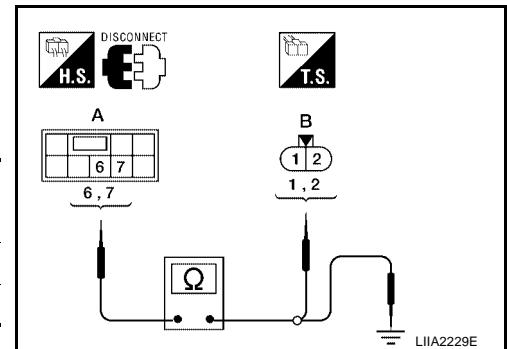

POWER WINDOW SYSTEM

3. CHECK REAR POWER WINDOW SWITCH LH

Check continuity between rear power window switch LH terminals.

Rear power window switch LH	Terminals		Continuity
	4	7	Yes
5	6	Yes	

OK or NG

OK >> GO TO 4.

NG >> Replace rear power window switch LH. Refer to [EI-26](#), "[REAR DOOR](#)".

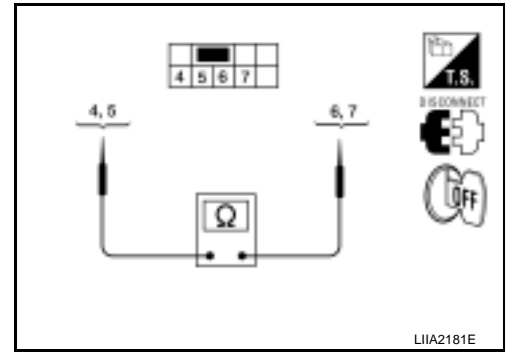

4. CHECK GROUND SUPPLY CIRCUIT

1. Disconnect main power window and door lock/unlock switch.
2. Check continuity between main power window and door lock/unlock switch connector and rear power window switch LH connector.

Connector	Terminal	Connector	Terminal	Continuity
A		B		
Main power window and door lock/unlock switch: D7	1	Rear power window switch LH: D203	4	Yes
	3		5	Yes

3. Check continuity between main power window and door lock/unlock switch connector and ground.

Connector	Terminal	Ground	Continuity
A			
Main power window and door lock/unlock switch: D7	1	Ground	No
	3		No

OK or NG

OK >> GO TO 5.

NG >> Repair or replace harness.

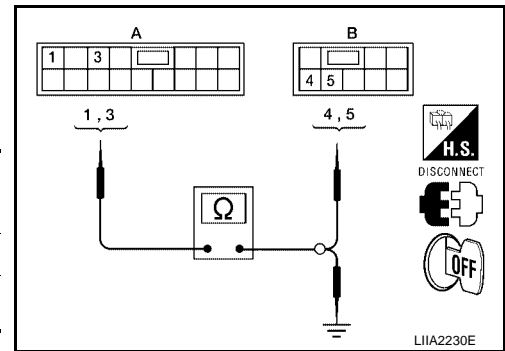

5. CHECK MAIN POWER WINDOW AND DOOR LOCK/UNLOCK SWITCH

Check continuity between main power window and door lock/unlock switch terminals.

Main power window and door lock/unlock switch	Terminals		Condition	Continuity
	17	1	Power window lock switch UNLOCK	Yes
Power window lock switch LOCK			No	
3		Power window lock switch UNLOCK	Yes	
		Power window lock switch LOCK	No	

OK or NG

OK >> Repair or replace harness.

NG >> Replace main power window and door lock/unlock switch. Refer to [EI-25](#), "[FRONT DOOR](#)".

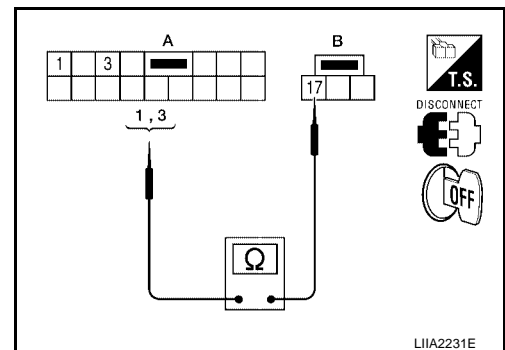

POWER WINDOW SYSTEM

Rear Power Window RH Circuit Check (Rear Power Window Switch RH Operation)

EIS007RW

1. CHECK REAR POWER WINDOW SWITCH RH OUTPUT SIGNAL

1. Turn ignition switch OFF.
2. Disconnect rear power window motor RH.
3. Turn ignition switch ON.
4. Check voltage between rear power window motor RH connector and ground.

Connector	Terminals		Condition	Voltage (V) (Approx.)
	(+)	(-)		
Rear power window motor RH: D304	1	Ground	UP	0
			DOWN	Battery voltage
	2		UP	Battery voltage
			DOWN	0

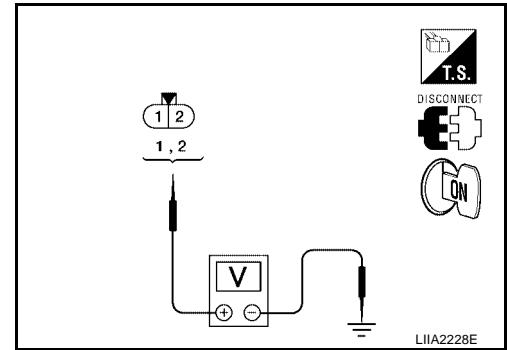

OK or NG

- OK >> Replace rear power window motor RH. Refer to [GW-62, "Rear Door Glass Regulator"](#).
- NG >> GO TO 2.

2. CHECK REAR POWER WINDOW MOTOR RH CIRCUIT

1. Turn ignition switch OFF.
2. Disconnect rear power window switch RH.
3. Check continuity between rear power window switch RH connector and rear power window motor RH connector.

Connector	Terminal	Connector	Terminal	Continuity
A		B		
Rear power window switch RH: D303	6	Rear power window motor RH: D304	1	Yes
	7		2	Yes

4. Check continuity between rear power window switch RH connector and ground.

Connector	Terminal	Continuity
A		
Rear power window switch RH: D303	6	No
	7	No

OK or NG

- OK >> GO TO 3.
- NG >> Repair or replace harness.

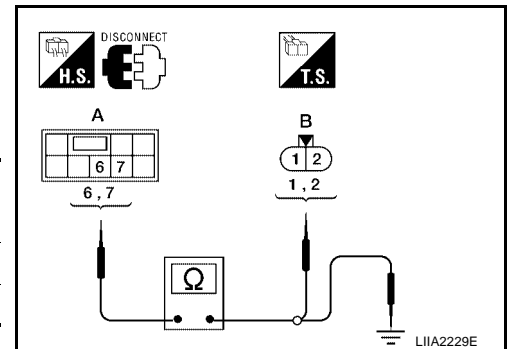

POWER WINDOW SYSTEM

3. CHECK POWER SUPPLY

1. Connect rear power window switch RH.
2. Turn ignition switch ON.
3. Check voltage between rear power window switch RH connector D303 terminal 8 and ground.

8 - Ground : Battery voltage

OK or NG

- OK >> GO TO 4.
NG >> GO TO 5.

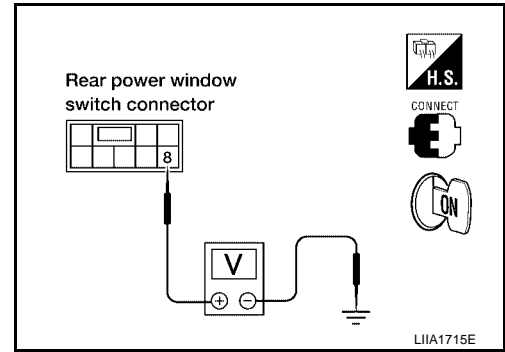

4. CHECK REAR POWER WINDOW SWITCH RH

1. Turn ignition switch OFF.
2. Disconnect rear power window switch RH.
3. Check continuity between rear power window switch RH terminals.

	Terminals		Condition	Continuity
	Rearpower window switch RH	6	5	DOWN
NEUTRAL or UP				Yes
8			NEUTRAL or UP	No
			DOWN	Yes
7		4	UP	No
			NEUTRAL or DOWN	Yes
		8	NEUTRAL or DOWN	No
			UP	Yes

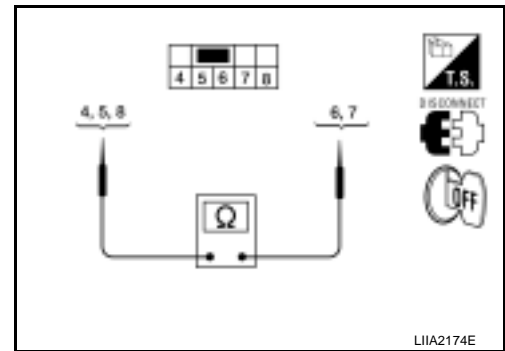

OK or NG

- OK >> GO TO 6.
NG >> Replace rear power window switch RH. Refer to [EI-26, "REAR DOOR"](#).

5. CHECK REAR POWER WINDOW SWITCH RH POWER SUPPLY CIRCUIT

1. Turn ignition switch OFF.
2. Disconnect BCM.
3. Check continuity between BCM connector and rear power window switch RH connector.

Connector	Terminal	Connector	Terminal	Continuity
A		B		
BCM: M20	68	Rear power window switch RH: D303	8	Yes

4. Check continuity between BCM and ground.

Connector	Terminal	Ground	Continuity
A			
BCM: M20	68		No

OK or NG

- OK >> GO TO 6.
NG >> Repair or replace harness.

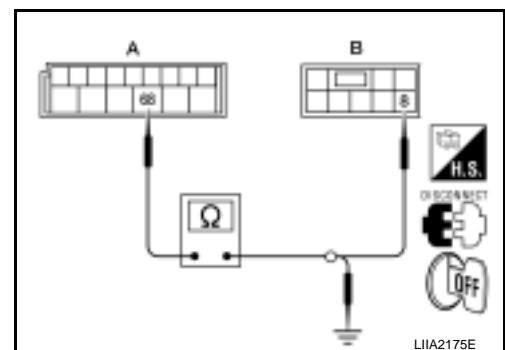

POWER WINDOW SYSTEM

6. CHECK REAR POWER WINDOW SWITCH RH GROUND SUPPLY

Check continuity between rear power window switch RH connector and ground.

Connector	Terminals	Continuity
Rear power window switch RH: D303	4	Yes
	5	Yes

OK or NG

- OK >> Check the condition of the harness and the connector.
- NG >> GO TO 7.

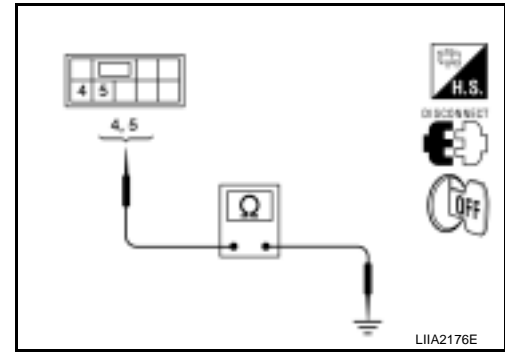

7. CHECK GROUND SUPPLY CIRCUIT

1. Disconnect main power window and door lock/unlock switch.
2. Check continuity between main power window and door lock/unlock switch connector and rear power window switch RH connector.

Connector A	Terminal	Connector B	Terminal	Continuity
Main power window and door lock/unlock switch: D7	5	Rear power window switch RH: D303	5	Yes
	7		4	Yes

3. Check continuity between main power window and door lock/unlock switch connector and ground.

Connector A	Terminal	Ground	Continuity
Main power window and door lock/unlock switch: D7	5	Ground	No
	7		No

OK or NG

- OK >> GO TO 8.
- NG >> Repair or replace harness.

8. CHECK MAIN POWER WINDOW AND DOOR LOCK/UNLOCK SWITCH

Check continuity between main power window and door lock/unlock switch terminals.

Main power window and door lock/unlock switch	Terminals	Condition	Continuity
	5	Power window lock switch UNLOCK	Yes
		Power window lock switch LOCK	No
	7	Power window lock switch UNLOCK	Yes
		Power window lock switch LOCK	No

OK or NG

- OK >> Repair or replace harness.
- NG >> Replace main power window and door lock/unlock switch. refer to [EI-25. "FRONT DOOR"](#) .

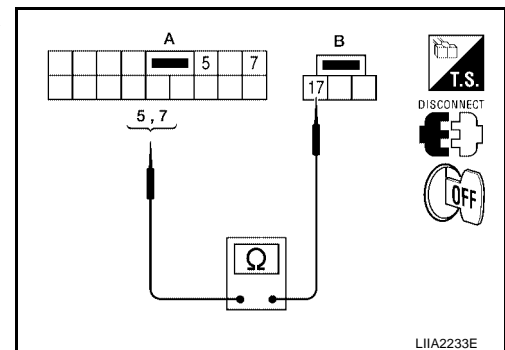

POWER WINDOW SYSTEM

Rear Power Window RH Circuit Check (Main Power Window and Door Lock/Unlock Switch Operation)

EIS007RX

1. CHECK MAIN POWER WINDOW AND DOOR LOCK/UNLOCK SWITCH OUTPUT SIGNAL

1. Turn ignition switch OFF.
2. Disconnect rear power window motor RH.
3. Turn ignition switch ON.
4. Check voltage between rear power window motor RH connector and ground.

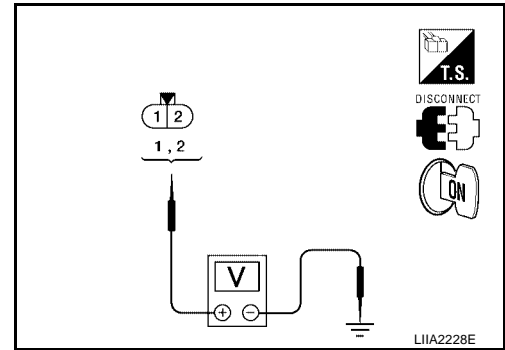

Connector	Terminals		Condition	Voltage (V) (Approx.)
	(+)	(-)		
Rear power window motor RH: D304	1	Ground	UP	0
			DOWN	Battery voltage
	2		UP	Battery voltage
			DOWN	0

OK or NG

- OK >> Replace rear power window motor RH. Refer to [GW-62, "Rear Door Glass Regulator"](#) .
 NG >> GO TO 2.

2. CHECK REAR POWER WINDOW MOTOR RH CIRCUIT

1. Turn ignition switch OFF.
2. Disconnect rear power window switch RH.
3. Check continuity between rear power window switch RH connector and rear power window motor RH connector.

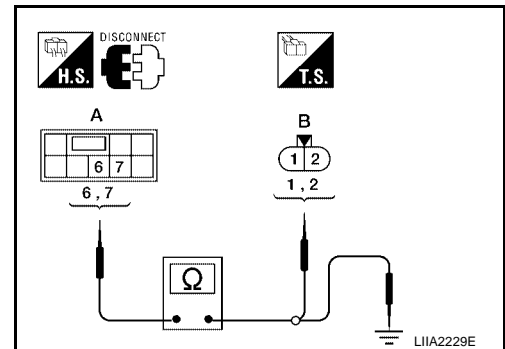

Connector	Terminal	Connector	Terminal	Continuity
A		B		
Rear power window switch RH: D303	6	Rear power window motor RH: D304	1	Yes
	7		2	Yes

4. Check continuity between rear power window switch RH connector and ground.

Connector	Terminal	Ground	Continuity
A			
Rear power window switch RH: D303	6		No
	7		No

OK or NG

- OK >> GO TO 3.
 NG >> Repair or replace harness.

POWER WINDOW SYSTEM

3. CHECK REAR POWER WINDOW SWITCH RH

Check continuity between rear power window switch RH terminals.

Rear power window switch RH	Terminals		Continuity
	4	7	Yes
5	6	Yes	

OK or NG

OK >> GO TO 4.

NG >> Replace rear power window switch RH. Refer to [EI-26, "REAR DOOR"](#).

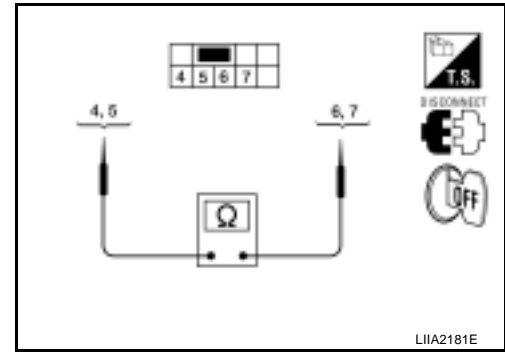

4. CHECK GROUND SUPPLY CIRCUIT

1. Disconnect main power window and door lock/unlock switch.
2. Check continuity between main power window and door lock/unlock switch connector and rear power window switch RH connector.

Connector	Terminal	Connector	Terminal	Continuity
A		B		
Main power window and door lock/unlock switch: D7	5	Rear power window switch RH: D303	5	Yes
	7		4	Yes

3. Check continuity between main power window and door lock/unlock switch and ground.

Connector	Terminal	Ground	Continuity
A			
Main power window and door lock/unlock switch: D7	5	Ground	No
	7		No

OK or NG

OK >> GO TO 5.

NG >> Repair or replace harness.

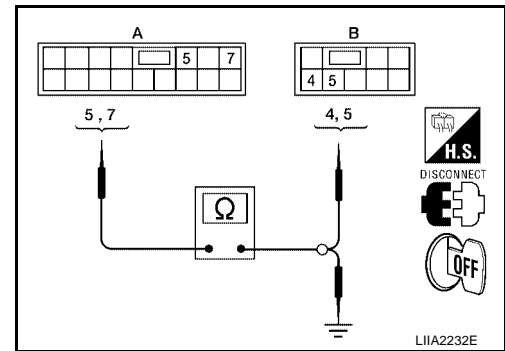

5. CHECK MAIN POWER WINDOW AND DOOR LOCK/UNLOCK SWITCH

Check continuity between main power window and door lock/unlock switch terminals.

Main power window and door lock/unlock switch	Terminals		Condition	Continuity
	17	5	Power window lock switch UNLOCK	Yes
Power window lock switch LOCK			No	
7	7	Power window lock switch UNLOCK	Yes	
		Power window lock switch LOCK	No	

OK or NG

OK >> Repair or replace harness.

NG >> Replace main power window and door lock/unlock switch. Refer to [EI-25, "FRONT DOOR"](#).

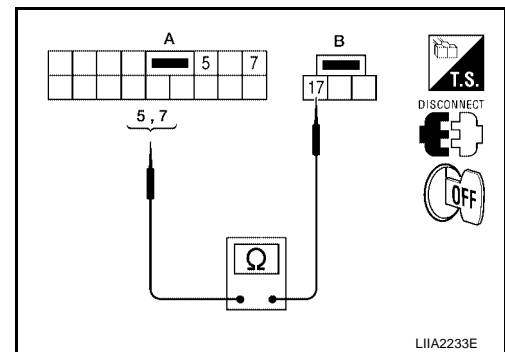

POWER WINDOW SYSTEM

EIS007RY

Rear Power Window Motor LH Circuit Check

1. CHECK REAR POWER WINDOW SWITCH LH OUTPUT SIGNAL

1. Turn ignition switch OFF.
2. Disconnect rear power window motor LH.
3. Turn ignition switch ON.
4. Check voltage between rear power window motor LH connector and ground.

Connector	Terminals		Condition	Voltage (V) (Approx.)
	(+)	(-)		
Rear power window motor LH: D204	1	Ground	UP	0
			DOWN	Battery voltage
	2		UP	Battery voltage
			DOWN	0

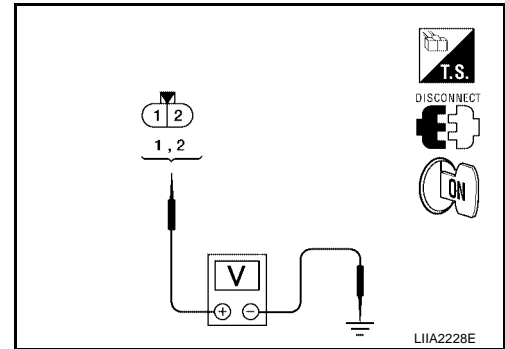

OK or NG

- OK >> Replace rear power window motor LH. Refer to [GW-62, "Rear Door Glass Regulator"](#) .
 NG >> GO TO 2.

2. CHECK REAR POWER WINDOW MOTOR LH CIRCUIT

1. Turn ignition switch OFF.
2. Disconnect rear power window switch LH.
3. Check continuity between rear power window switch LH connector (A) and rear power window motor LH connector (B).

6 - 1 : Continuity should exist.
7 - 2 : Continuity should exist.

OK or NG

- OK >> GO TO 3.
 NG >> Repair or replace harness.

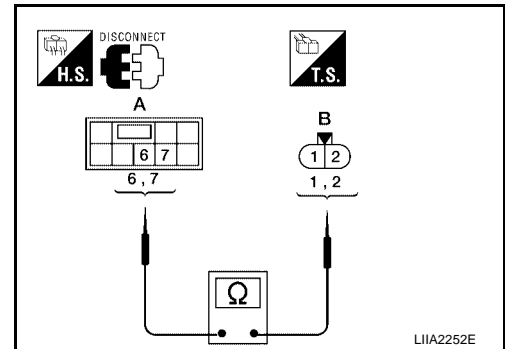

3. CHECK POWER SUPPLY

1. Connect rear power window switch LH.
2. Turn ignition switch ON.
3. Check voltage between rear power window switch LH connector D203 terminal 8 and ground.

8 - Ground : Battery voltage

OK or NG

- OK >> Replace rear power window switch LH. Refer to [EI-26, "REAR DOOR"](#) .
 NG >> Repair or replace harness.

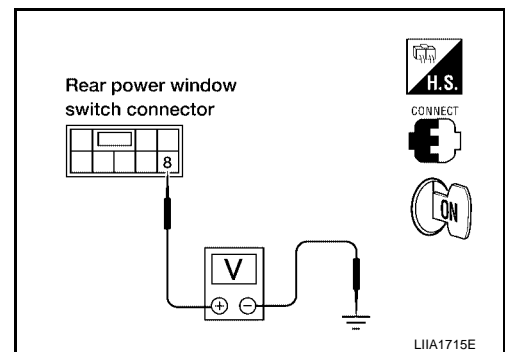

POWER WINDOW SYSTEM

EIS007RZ

Rear Power Window Motor RH Circuit Check

1. CHECK REAR POWER WINDOW SWITCH RH OUTPUT SIGNAL

1. Turn ignition switch OFF.
2. Disconnect rear power window motor RH.
3. Turn ignition switch ON.
4. Check voltage between rear power window motor RH connector and ground.

Connector	Terminals		Condition	Voltage (V) (Approx.)
	(+)	(-)		
Rear power window motor RH: D304	1	Ground	UP	0
			DOWN	Battery voltage
	2		UP	Battery voltage
			DOWN	0

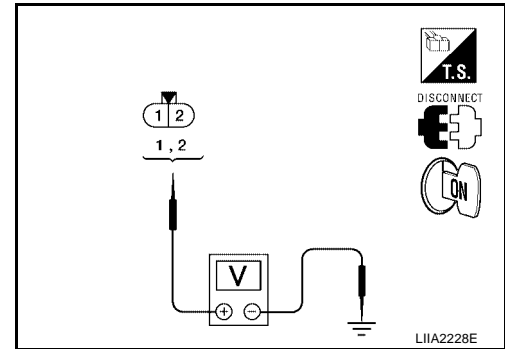

OK or NG

- OK >> Replace rear power window motor RH. Refer to [GW-62, "Rear Door Glass Regulator"](#) .
 NG >> GO TO 2.

2. CHECK REAR POWER WINDOW MOTOR RH CIRCUIT

1. Turn ignition switch OFF.
2. Disconnect rear power window switch RH.
3. Check continuity between rear power window switch RH connector (A) and rear power window motor RH connector (B).

- 6 - 1** : Continuity should exist.
7 - 2 : Continuity should exist.

OK or NG

- OK >> GO TO 3.
 NG >> Repair or replace harness.

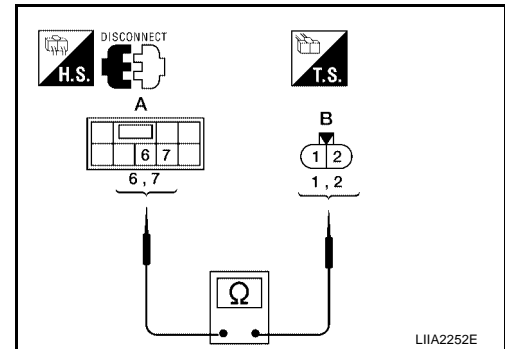

3. CHECK POWER SUPPLY

1. Connect rear power window switch RH.
2. Turn ignition switch ON.
3. Check voltage between rear power window switch RH connector D303 terminal 8 and ground.

- 8 - Ground** : Battery voltage

OK or NG

- OK >> Replace rear power window switch RH. Refer to [EI-26, "REAR DOOR"](#) .
 NG >> Repair or replace harness.

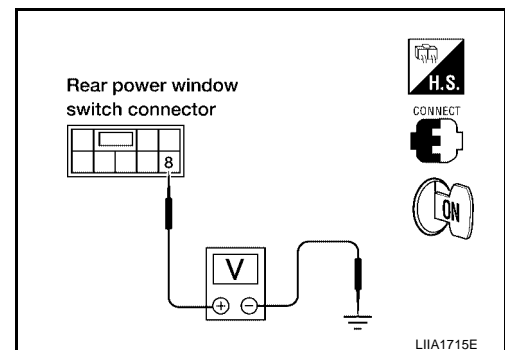

FRONT DOOR GLASS AND REGULATOR

PFP:80300

FRONT DOOR GLASS AND REGULATOR

Front Door Glass REMOVAL

EIS007S0

1. Remove the front door finisher. Refer to [EI-25, "FRONT DOOR"](#) .
2. Temporarily reconnect the power window switch.
3. Operate the power window main switch to raise/lower the door window until the glass bolts can be seen.
4. Remove the inside seal.
5. Remove the glass bolts.

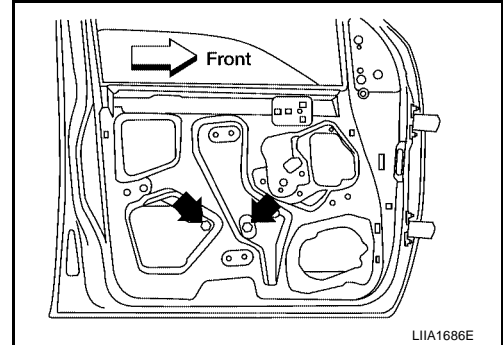

6. While holding the door window, raise it at the rear and pull the glass out of the sash toward the outside of the door.

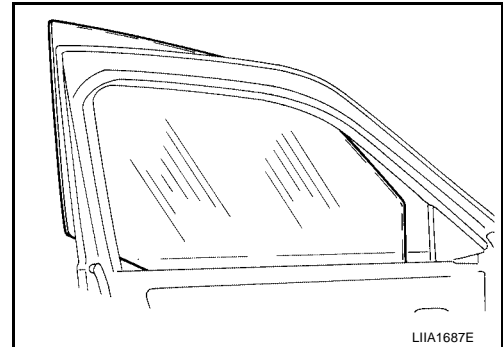

INSTALLATION

Installation is in the reverse order of removal.

Glass bolts : 6.1 N-m (0.62 kg-m, 54 in-lb)

- Check the glass for proper fit. Refer to [GW-57, "FITTING INSPECTION"](#) .
- On the drivers door, reset the motor. Refer to [GW-60, "SETTING AFTER INSTALLATION"](#) .

FITTING INSPECTION

- Check that the glass is securely fit into the glass run groove.
- Lower the glass slightly [approximately 10 to 20 mm (0.39 to 0.79 in)] and check that the clearance to the sash is parallel. If the clearance between the glass and sash is not parallel, loosen the regulator bolts, guide rail bolts, and glass and guide rail bolts to correct the glass position.

FRONT DOOR GLASS AND REGULATOR

EIS007S1

Front Door Glass Regulator REMOVAL

1. Remove the front door finisher. Refer to [EI-25, "FRONT DOOR"](#).
2. Temporarily reconnect the power window switch.
3. Operate the power window main switch to raise/lower the door window until the glass bolts can be seen.
4. Remove the inside seal.
5. Remove the glass bolts.

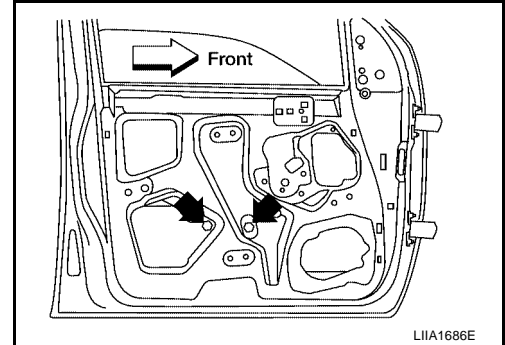

6. Raise the front door glass and hold it in place with suitable tool.
7. Disconnect the harness connector from the regulator assembly.
8. Remove the bolts and the regulator assembly.

SEC. 803

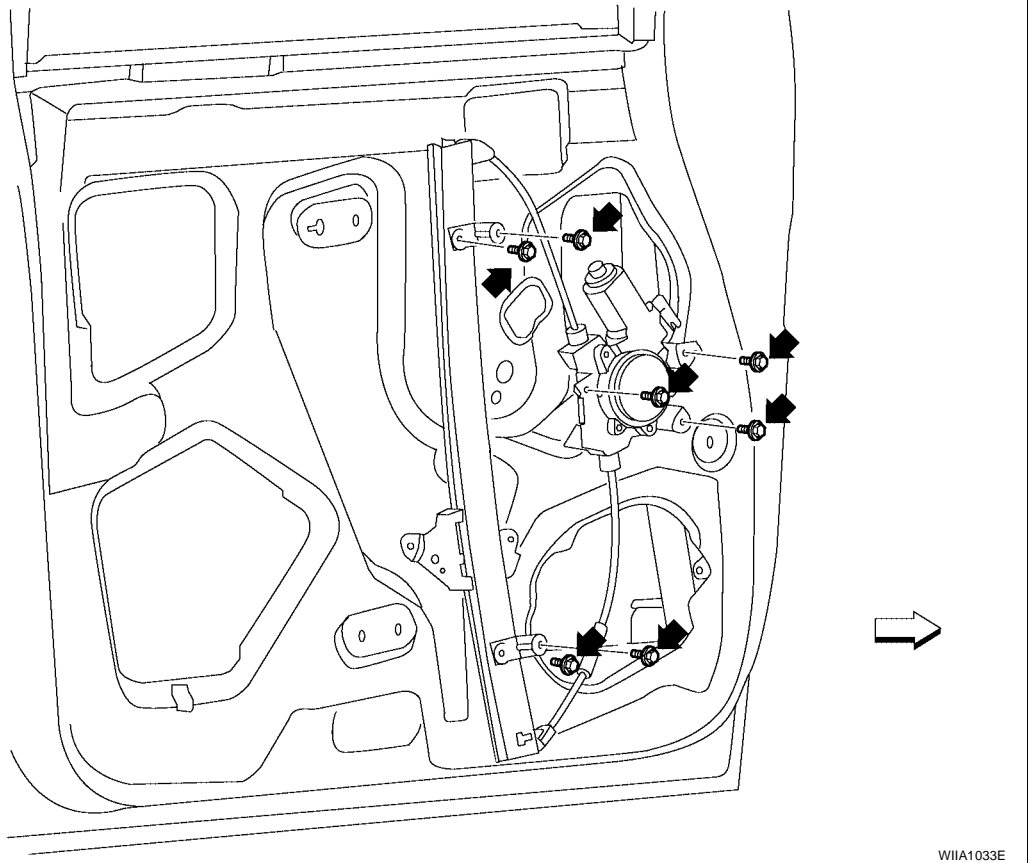

DISASSEMBLY AND ASSEMBLY

Remove the regulator motor from the regulator assembly.

INSPECTION AFTER REMOVAL

Check the regulator assembly for the following items. If a malfunction is detected, replace or grease it.

- Wire wear
- Regulator deformation
- Grease condition for each sliding part

FRONT DOOR GLASS AND REGULATOR

INSTALLATION

SEC. 803

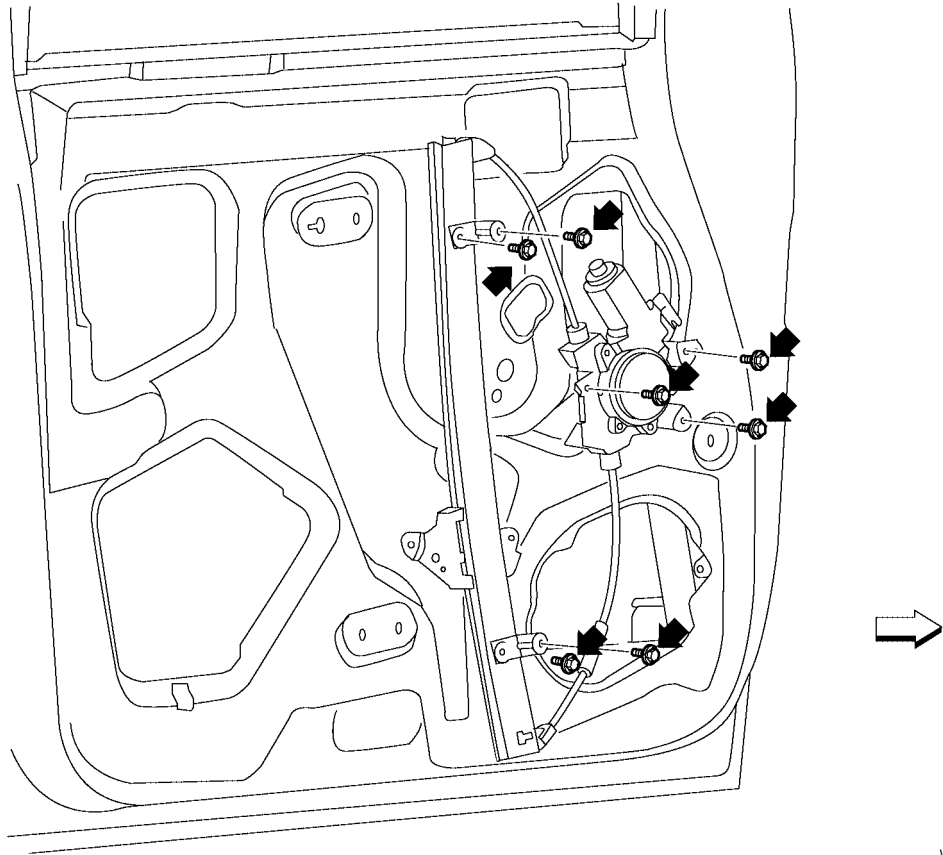

WIIA1033E

1. Install the regulator assembly.
 - a. Loosely install the top rear regulator bolt to use along with the temporary holds on the window motor to install the assembly in the door.
 - b. Install the top front regulator bolt.
 - c. Install the bottom front regulator bolt.
 - d. Install the bottom rear regulator bolt.
 - e. Tighten the top rear regulator bolt.
 - f. Install the top window motor bolt.
 - g. Install the lower window motor bolt
 - h. Install the rear window motor bolt.

Regulator and motor bolts : 5.7 N-m (0.58 kg-m, 50 in-lb)

2. Connect the harness connector to the regulator assembly.
3. Lower the glass and ensure that it is in both the front and rear glass channels. Tighten glass bolts.

Glass mounting bolts : 6.1 N-m (0.62 kg-m, 54 in-lb)

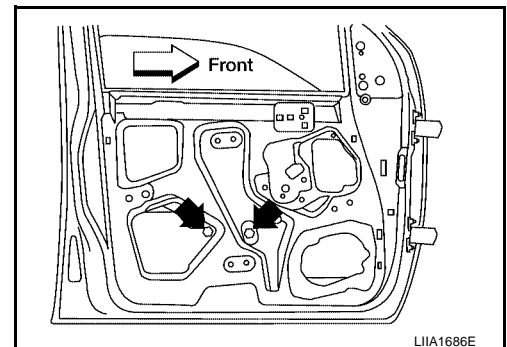

LIIA1686E

4. Check the glass for proper fit. Refer to [GW-57, "FITTING INSPECTION"](#) .
5. On the drivers door, reset the motor. Refer to [GW-60, "SETTING AFTER INSTALLATION"](#) .
6. Install the inside seal.

FRONT DOOR GLASS AND REGULATOR

7. Install front door finisher. Refer to [EI-25, "FRONT DOOR"](#).

SETTING AFTER INSTALLATION

Setting of Limit Switch

If any of the following work has been done, set the limit switch (integrated in the motor).

- Removal and installation of the regulator.
- Removal and installation of the motor from the regulator.
- Removal and installation of the glass.
- Removal and installation of the glass run.

Resetting

After installing each component, perform the following procedure to reset the limit switch.

1. Raise the glass to the top position.
2. While pressing and holding the reset switch, lower the glass to the bottom position.
3. Release the reset switch. Verify that the reset switch returns to the original position, if not, pull the switch using suitable tool.
4. Raise the glass to the top position.

CAUTION:

Do not operate the glass automatically to raise the glass to the top position.

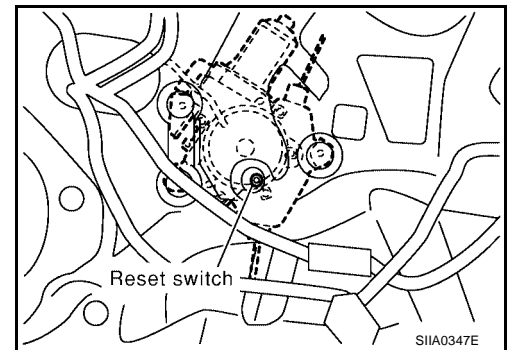

REAR DOOR GLASS AND REGULATOR

PFP:82300

REAR DOOR GLASS AND REGULATOR

Rear Door Glass REMOVAL

EIS007S2

1. Remove the rear door finisher. Refer to [EI-25, "DOOR FINISHER"](#) .
2. Remove the inside seal.
3. Temporarily reconnect the power window switch.
4. Remove the glass run from the partition glass.
5. Operate the power window switch to raise/lower the door window until the glass bolts can be seen.
6. Remove the partition sash bolt (lower) and screw (upper) to remove the sash.
7. Remove the bolts and the glass.

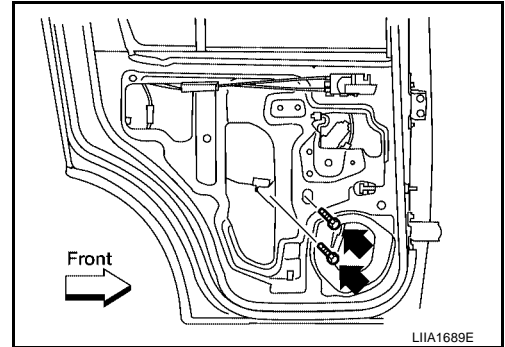

INSTALLATION

Installation is in the reverse order of removal.

Glass bolts : 5.7 N·m (0.58 kg·m, 50 in-lb)

- Check the glass alignment. Refer to [GW-61, "FITTING INSPECTION"](#) .

FITTING INSPECTION

- Check that the glass is securely fit into the glass run groove.
- Lower the glass slightly [approximately 10 to 20 mm (0.39 to 0.79 in)], and check that the clearance to the sash is parallel. If the clearance between the glass and sash is not parallel, loosen the regulator bolts, guide rail bolts, and glass carrier plate bolts to correct the glass position.

A

B

C

D

E

F

G

H

GW

J

K

L

M

REAR DOOR GLASS AND REGULATOR

EIS007S3

Rear Door Glass Regulator REMOVAL

1. Remove the rear door finisher. Refer to [EI-25, "DOOR FINISHER"](#) .
2. Remove the inside seal.
3. Temporarily reconnect the power window switch.
4. Operate the power window switch to raise/lower the door window until the glass bolts can be seen.

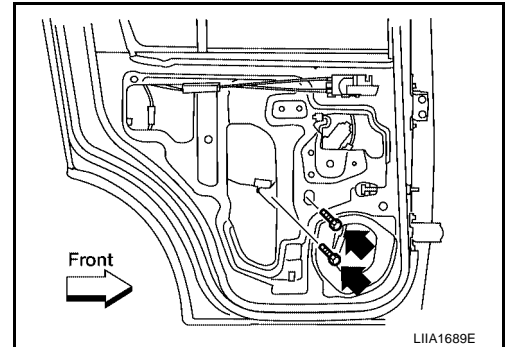

5. Raise the rear door glass and hold it in place with suitable tool.
6. Remove the bolts and the regulator assembly.
 - Disconnect the connector from the regulator assembly.

SEC. 823

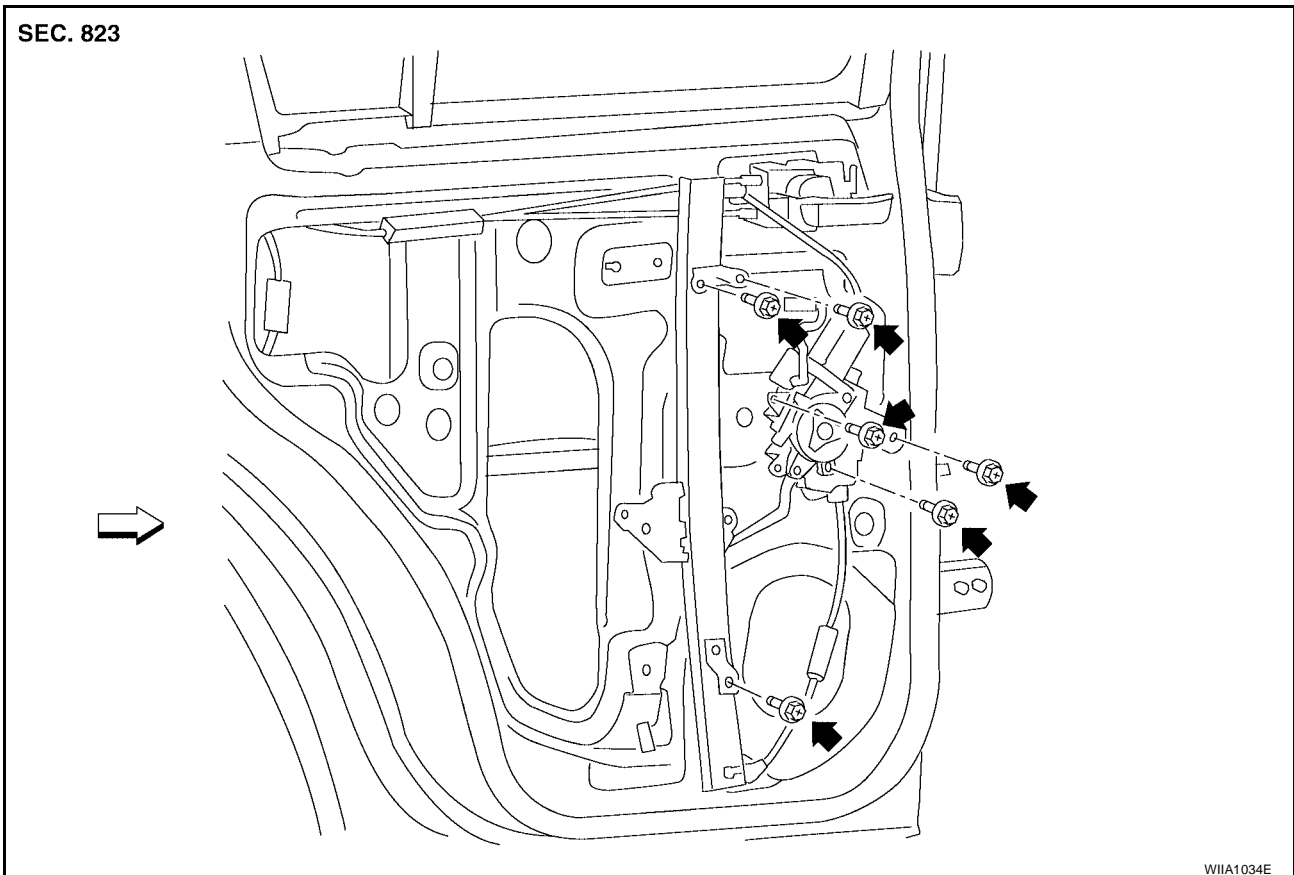

INSPECTION AFTER REMOVAL

Check the regulator assembly for the following items. If a malfunction is detected, replace or grease it.

- Gear wear
- Regulator deformation
- Spring damage
- Grease condition for each sliding part

REAR DOOR GLASS AND REGULATOR

INSTALLATION

1. Connect the harness connector and install the regulator assembly.

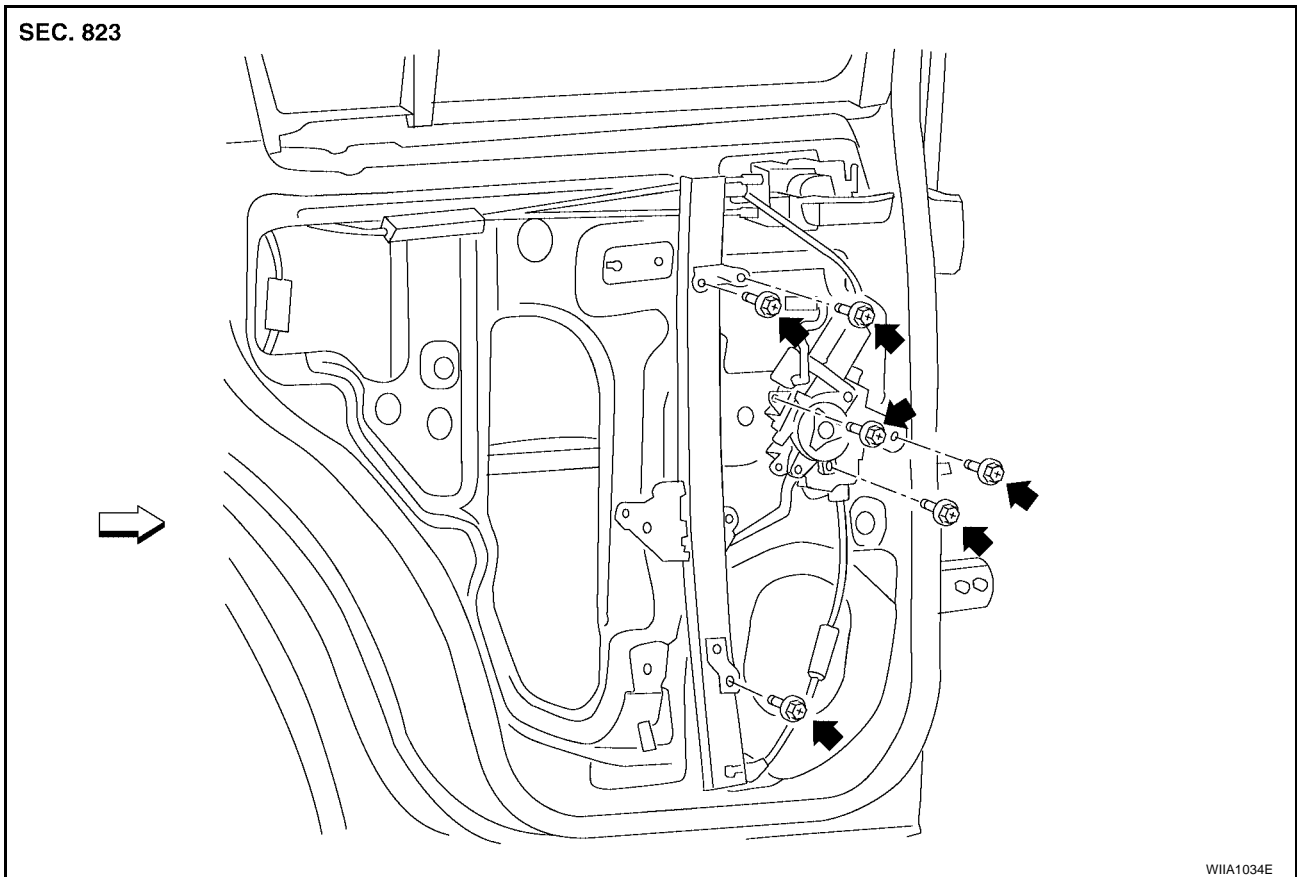

- a. Loosely install the top rear regulator bolt to use along with the temporary holds on the window motor to install the assembly in the door.
- b. Install the top front regulator bolt.
- c. Install the bottom regulator bolt.
- d. Tighten the top rear regulator bolt.
- e. Install the top window motor bolt.
- f. Install the lower window motor bolt.
- g. Install the front window motor bolt.

Regulator assembly : 7.5 N·m (0.77 kg-m, 66 in-lb)

2. Lower the glass and ensure that it is in both the front and rear glass channels. Tighten the bolts.

Glass bolts : 5.7 N·m (0.58 kg-m, 50 in-lb)

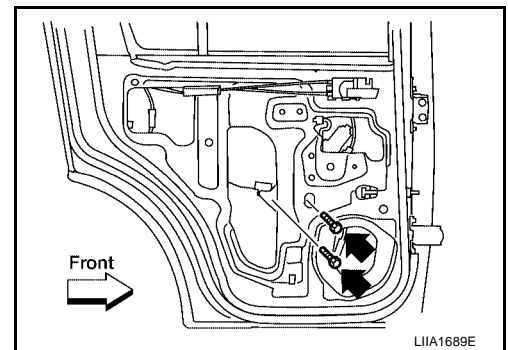

3. Install the partition sash
4. Check the glass alignment. Refer to [GW-61, "FITTING INSPECTION"](#).
5. Install the inside seal.
6. Install the rear door finisher. Refer to [EI-25, "DOOR FINISHER"](#).

SIDE WINDOW GLASS

SIDE WINDOW GLASS Removal and Installation

PF0:83300

EIS007S4

SEC. 830

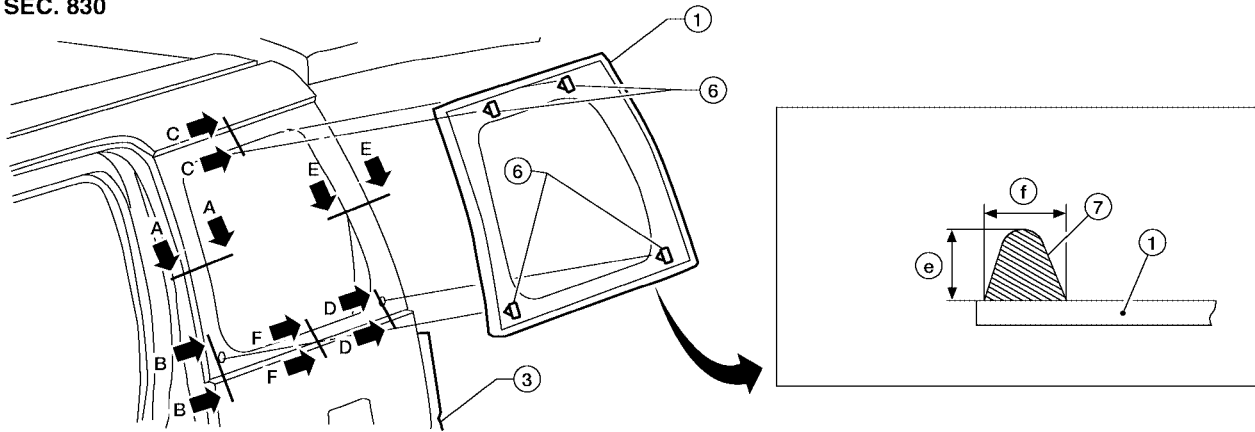

A-A

B-B

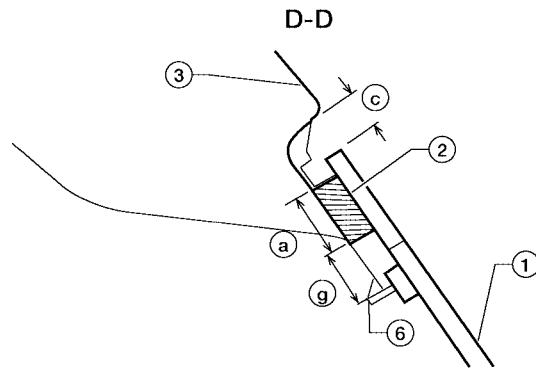
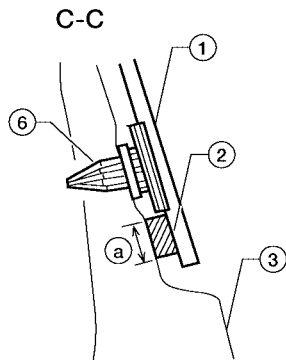
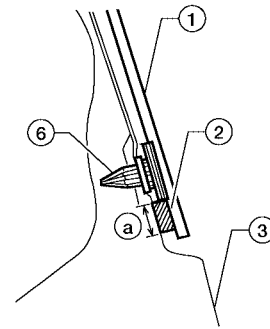
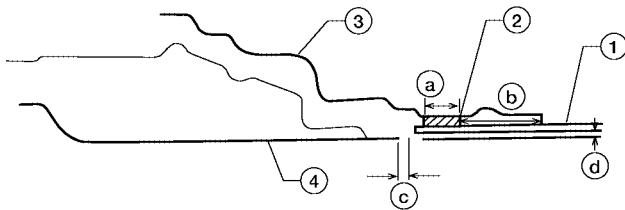

E-E

F-F

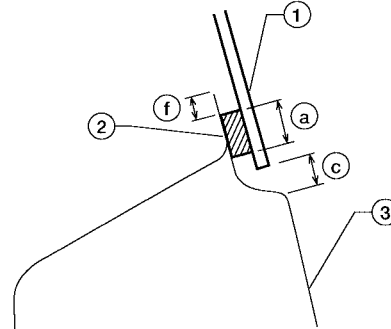
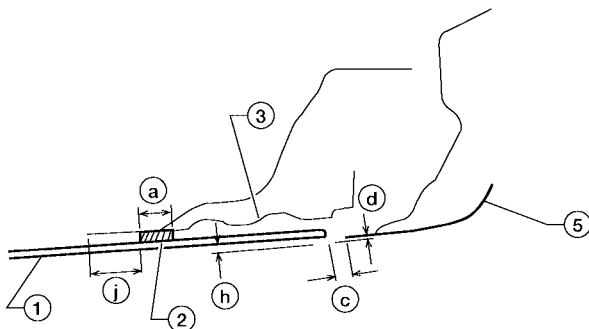

WIIA1035E

SIDE WINDOW GLASS

- | | | |
|-----------------------|-----------------------|----------------------|
| 1. Glass | 2. Primer area | 3. Body side outer |
| 4. Rear door assembly | 5. Back door assembly | 6. Locating clips |
| 7. Urethane | a. 15 mm (0.59 in) | b. 42.5 mm (1.67 in) |
| c. 3.0 mm (0.12 in) | d. 2.5 mm (0.1 in) | e. 12 mm (0.47 in) |
| f. 7.0 mm (0.28 in) | g. 11.5 mm (0.45 in) | h. 3.3 mm (0.13 in) |
| j. 30 mm (1.2 in) | | |

REMOVAL

1. Remove the luggage side upper finisher. Refer to [EI-27, "BODY SIDE TRIM"](#) .
 - a. Disconnect the antenna.
 - b. If the window glass is to be reused, mark the body and the glass with mating marks.
 - c. Remove the glass using piano wire or power cutting tool and an inflatable pump bag.

WARNING:

When cutting the glass from the vehicle, always wear safety glasses and heavy gloves to help prevent glass splinters from entering your eyes or cutting your hands.

CAUTION:

- **When the side window glass is to be reused, do not use a cutting knife or power cutting tool.**
- **Be careful not to scratch the glass when removing.**
- **Do not set or stand the glass on its edge. Small chips may develop into cracks.**

INSTALLATION

- Use a genuine NISSAN Urethane Adhesive Kit (if available) or equivalent and follow the instructions furnished with it.
- While the urethane adhesive is curing, open a door window. This will prevent the glass from being forced out by passenger compartment air pressure when a door is closed.
- Check gap along bottom to confirm that glass does not contact sheet metal.
- Inform the customer that the vehicle should remain stationary until the urethane adhesive has completely cured (preferably 24 hours). Curing time varies with temperature and humidity.
- Install parts removed.

WARNING:

- **Keep heat and open flames away as primers and adhesive are flammable.**
- **The materials contained in the kit are harmful if swallowed, and may irritate skin and eyes. Avoid contact with the skin and eyes.**
- **Use in an open, well ventilated location. Avoid breathing the vapors. They can be harmful if inhaled. If affected by vapor inhalation, immediately move to an area with fresh air.**
- **Driving the vehicle before the urethane adhesive has completely cured may affect the performance of the glass in case of an accident.**

CAUTION:

- **Do not use an adhesive which is past its usable term. Shelf life of this product is limited to six months after the date of manufacture. Carefully adhere to the expiration or manufacture date printed on the box.**
- **Keep primers and adhesive in a cool, dry place. Ideally, they should be stored in a refrigerator.**
- **Do not leave primers or adhesive cartridge unattended with their caps open or off.**
- **The vehicle should not be driven for at least 24 hours or until the urethane adhesive has completely cured. Curing time varies depending on temperature and humidity. The curing time will increase under lower temperatures and lower humidities.**

Repairing Water Leaks for Side Window Glass

Leaks can be repaired without removing or reinstalling glass.

If water is leaking between urethane adhesive material and body or glass, determine the extent of leakage.

This can be done by applying water to the side window area while pushing glass outward.

To stop leak, apply primer (if necessary) and then urethane adhesive to the leak point.

GLASS HATCH

PFP:90550

EIS007S5

GLASS HATCH

Removal and Installation

SEC.900

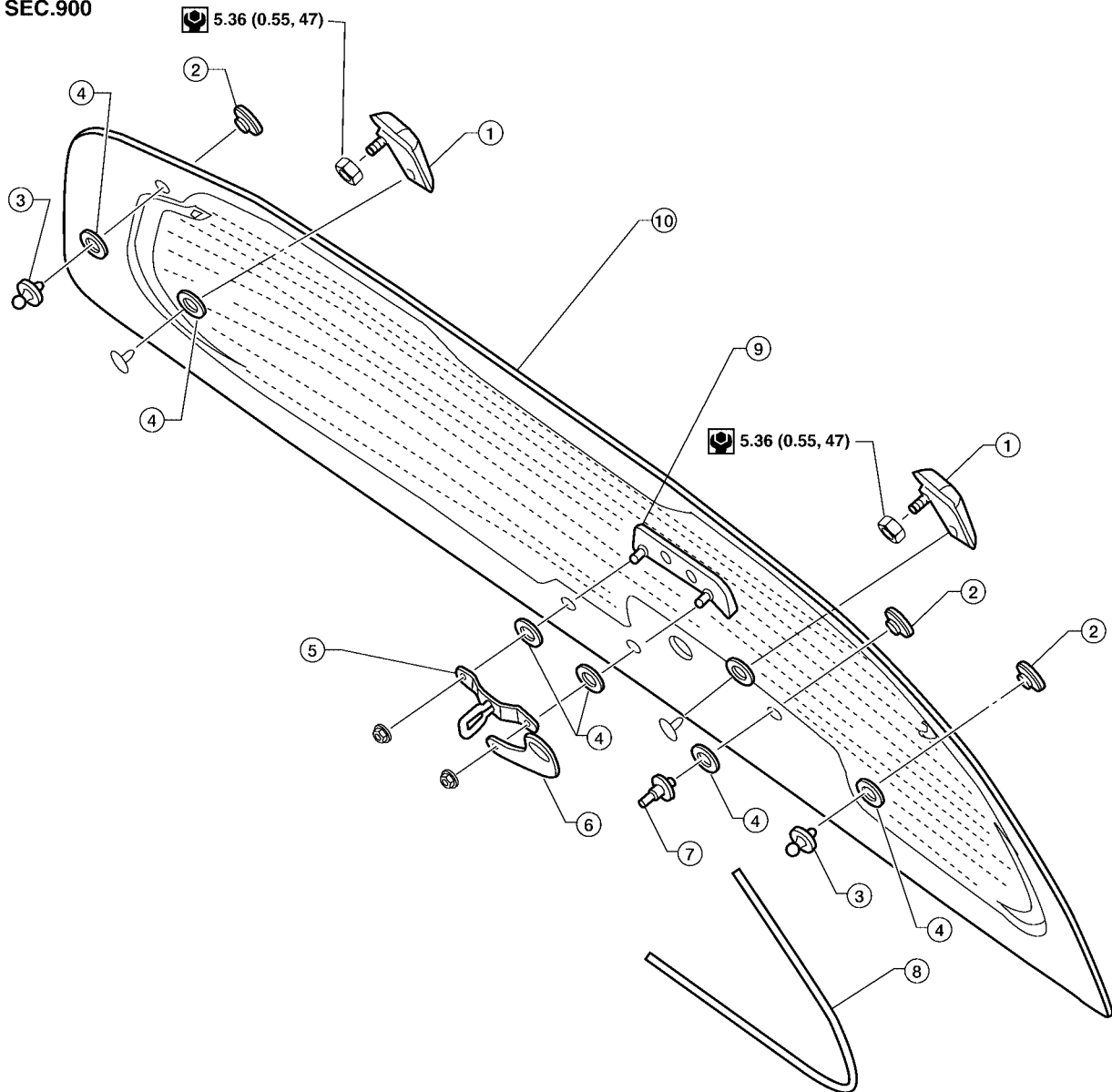

 : N-m (kg-m, in-lb)

W1IA0743E

- | | | |
|---------------------------------|------------------------|-----------------------------|
| 1. Glass hatch hinge RH/LH | 2. Glass hatch stud | 3. Gas stay ball stud RH/LH |
| 4. Bushing | 5. Glass hatch striker | 6. Wiper motor bracket |
| 7. Wiper motor stud | 8. Harness protector | 9. Glass hatch |
| 10. Glass hatch handle assembly | | |

1. Remove the rear wiper motor assembly. Refer to [WW-43, "REAR WIPER MOTOR"](#) .
2. Disconnect the rear defroster electrical connectors.
3. Remove the back door top garnish assembly. Refer to [EI-35, "BACK DOOR TRIM"](#) .
4. Remove the glass hatch stays.
5. Remove the glass hatch assembly.

GLASS HATCH

CAUTION:

- Be careful not to scratch the glass when removing.
- Do not set or stand the glass on its edge. Small chips may develop into cracks.

Installation is in the reverse order of removal.

A

B

C

D

E

F

G

H

GW

J

K

L

M

INSIDE MIRROR

PFP:96321

INSIDE MIRROR

Wiring Diagram — I/MIRR —

EIS007S6

GW-I/MIRR-01

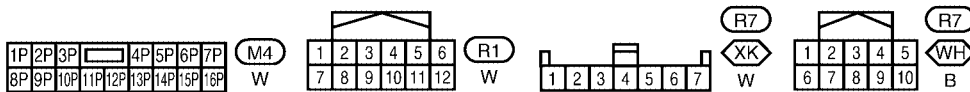
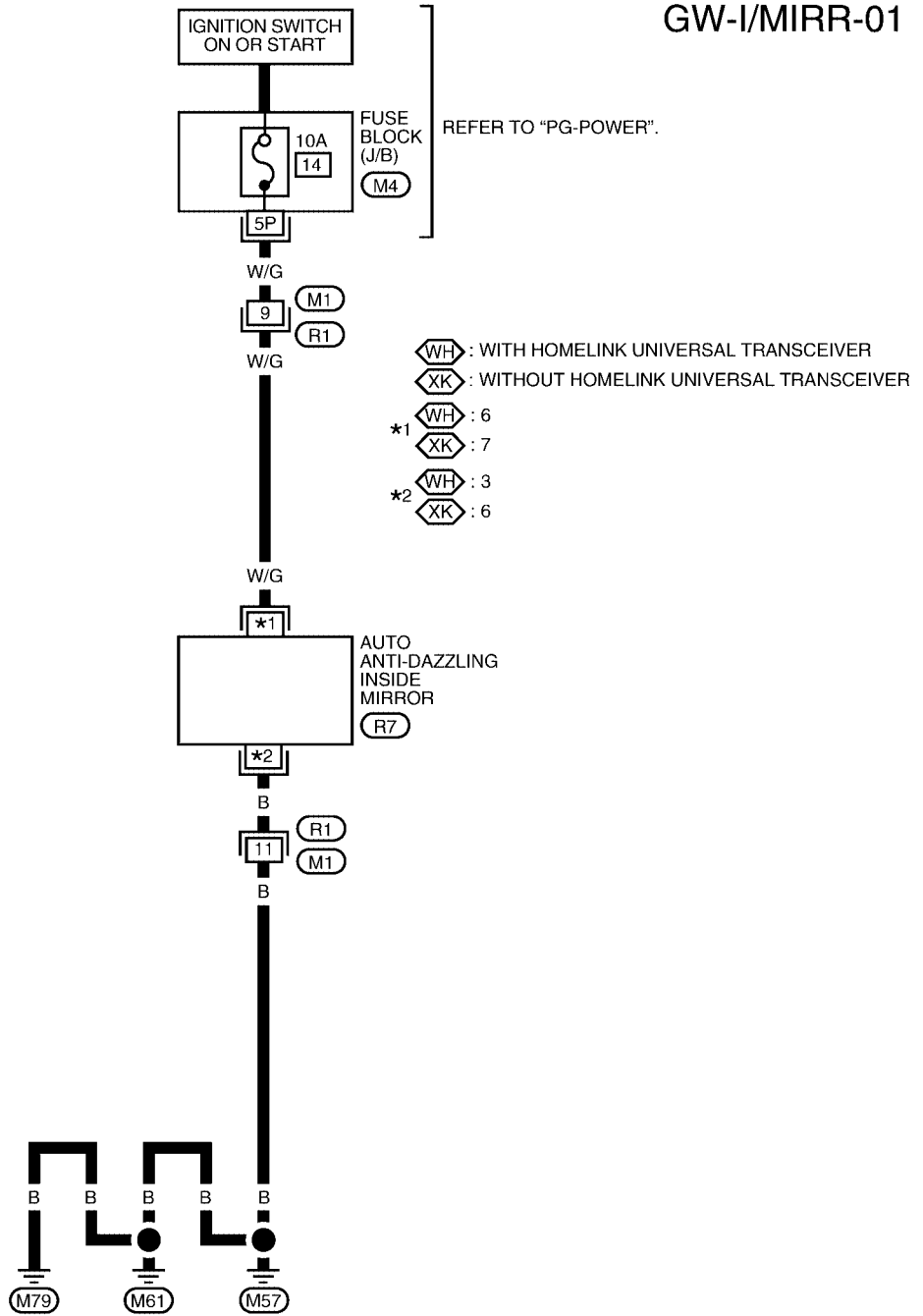

WIWA1040E

INSIDE MIRROR

EIS007S7

Removal and Installation INSIDE MIRROR

1. Remove inside mirror finisher.
2. Slide the mirror upward to remove.
3. Disconnect the connector.

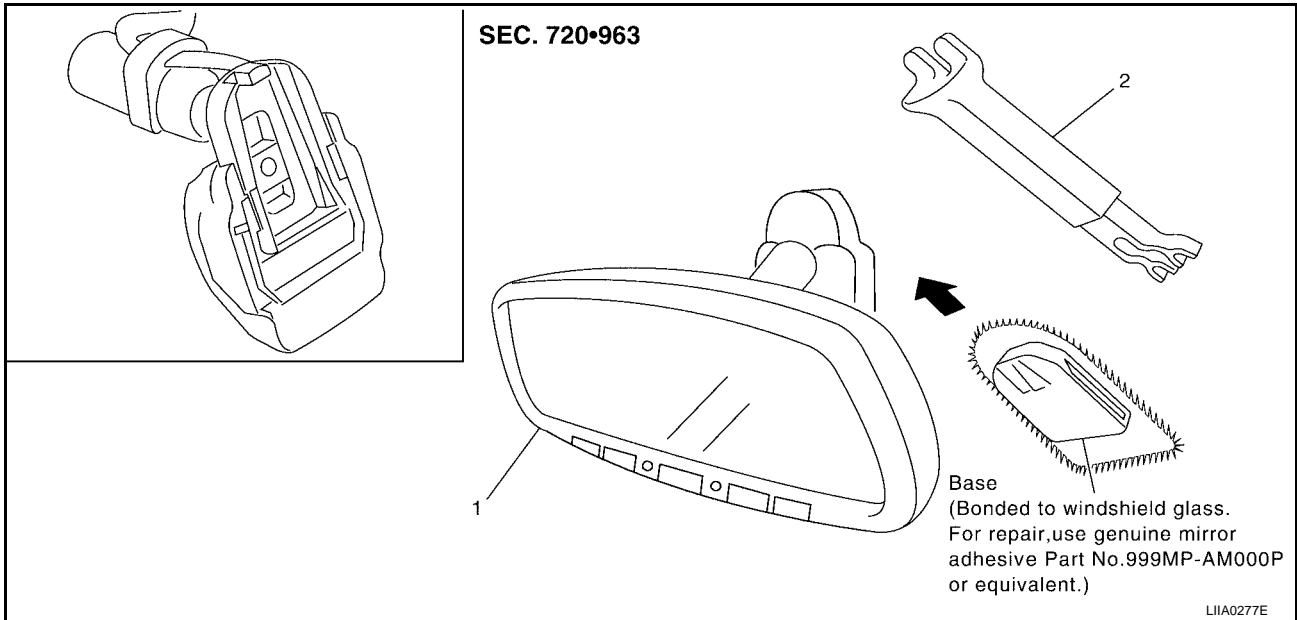

1. Inside mirror

2. Inside mirror finisher

Installation is in the reverse order of removal.

A
B
C
D
E
F
G
H

GW

J
K
L
M

REAR WINDOW DEFOGGER

PFP:25350

REAR WINDOW DEFOGGER

Component Parts and Harness Connector Location

EIS007S8

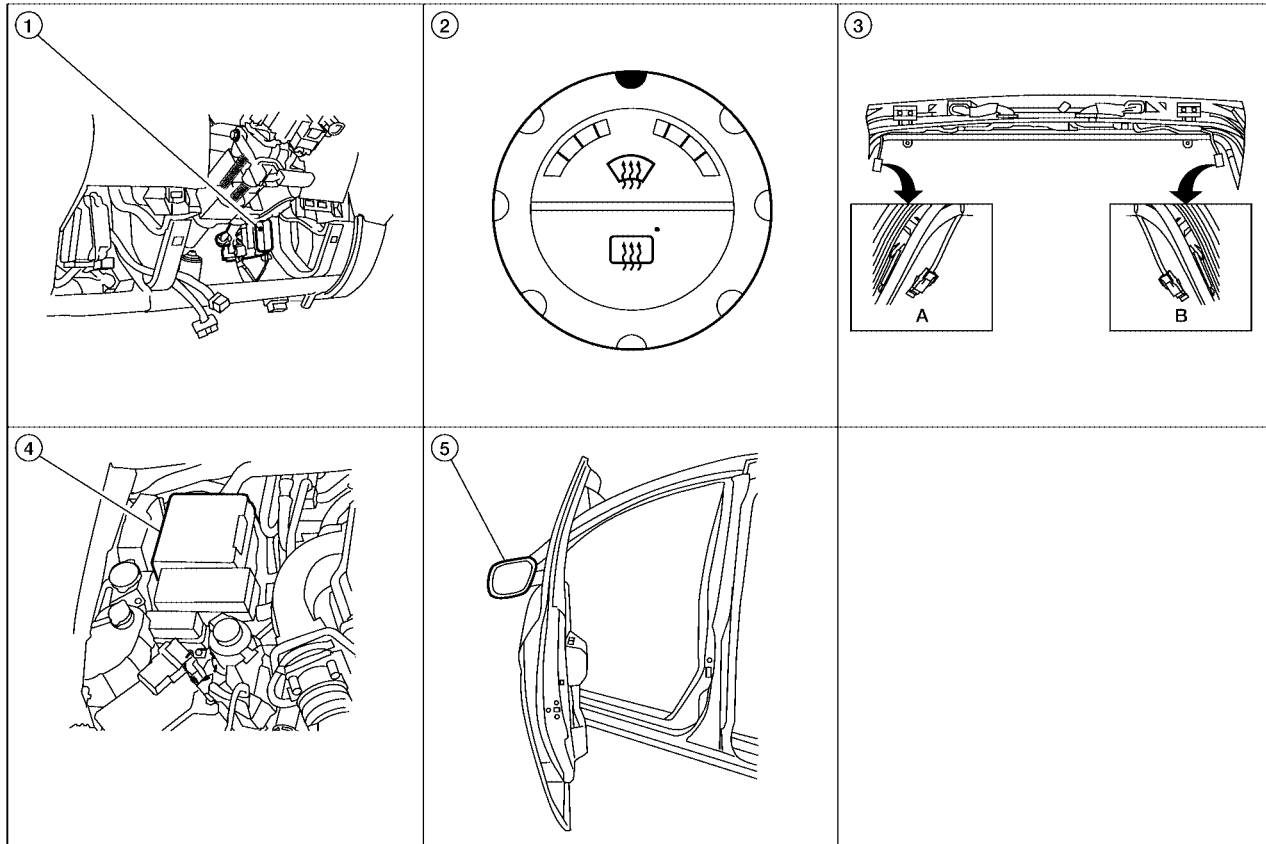

LIA2391E

1. BCM M18, M20 (view with lower instrument panel LH removed)

2. Front air control M49, M50

3. A. Rear window defogger ground connector D604
B. Rear window defogger connector D651

4. IPDM E/R E120, E122, E124

5. Door mirror LH (door mirror defogger) D4, RH D107

System Description

EIS007S9

The rear window defogger system is controlled by BCM (body control module) and IPDM E/R (intelligent power distribution module engine room).

The rear window defogger only operates for approximately 15 minutes.

Power is supplied at all times

- through 15A fuses (No. 46 and 47, located in the IPDM E/R)
- to rear window defogger relay
- through 15A fuse [No. 43 (with heated mirrors), located in the IPDM E/R]
- to heated mirror relay
- through 50A fusible link (letter **g**, located in the fuse and fusible link box)
- to BCM terminal 70.

With the ignition switch turned to ON or START position, power is supplied

- through ignition relay
- to rear window defogger relay (located in the IPDM E/R)
- through 10A fuse [No. 1, located in the fuse block (J/B)]
- to BCM terminal 38
- through 10A fuse [No. 8, located in the fuse block (J/B)]
- to front air control terminal 6.

REAR WINDOW DEFOGGER

Ground is supplied

- to BCM terminal 67
- to front air control terminal 20
- through body grounds M57, M61 and M79
- to IPDM E/R terminals 38 and 59
- through body grounds E9, E15 and E24.

When front air control (rear window defogger switch) is turned to ON, ground is supplied

- to BCM terminal 9
- through front air control terminal 11
- through front air control terminal 20
- through body grounds M57, M61 and M79.

Then rear window defogger switch is illuminated.

Then BCM recognizes that rear window defogger switch is turned to ON.

Then it sends rear window defogger switch signals to IPDM E/R via CAN communication (CAN-H, CAN-L).

When IPDM E/R receives rear window defogger switch signals, ground is supplied

- to rear window defogger relay (located in the IPDM E/R)
- through IPDM E/R terminals 38 and 59
- through body grounds E9, E15 and E24

Then rear window defogger relay is energized.

With power and ground supplied, rear window defogger filaments heat and defog the rear window.

When rear window defogger relay is turned to ON (with heated mirrors), power is supplied

- through heated mirror relay (located in the IPDM E/R)
- through IPDM E/R terminal 23
- to door mirror defogger (LH and RH) terminal 1.

Door mirror defogger (LH and RH) is grounded through body grounds M57, M61 and M79.

With power and ground supplied, rear window defogger filaments heat and defog the rear window and door mirror defogger filaments heat and defog the mirrors.

CAN Communication System Description

EIS007SA

Refer to [LAN-25, "CAN COMMUNICATION"](#) .

A

B

C

D

E

F

G

H

GW

J

K

L

M

REAR WINDOW DEFOGGER

Schematic

EIS007SB

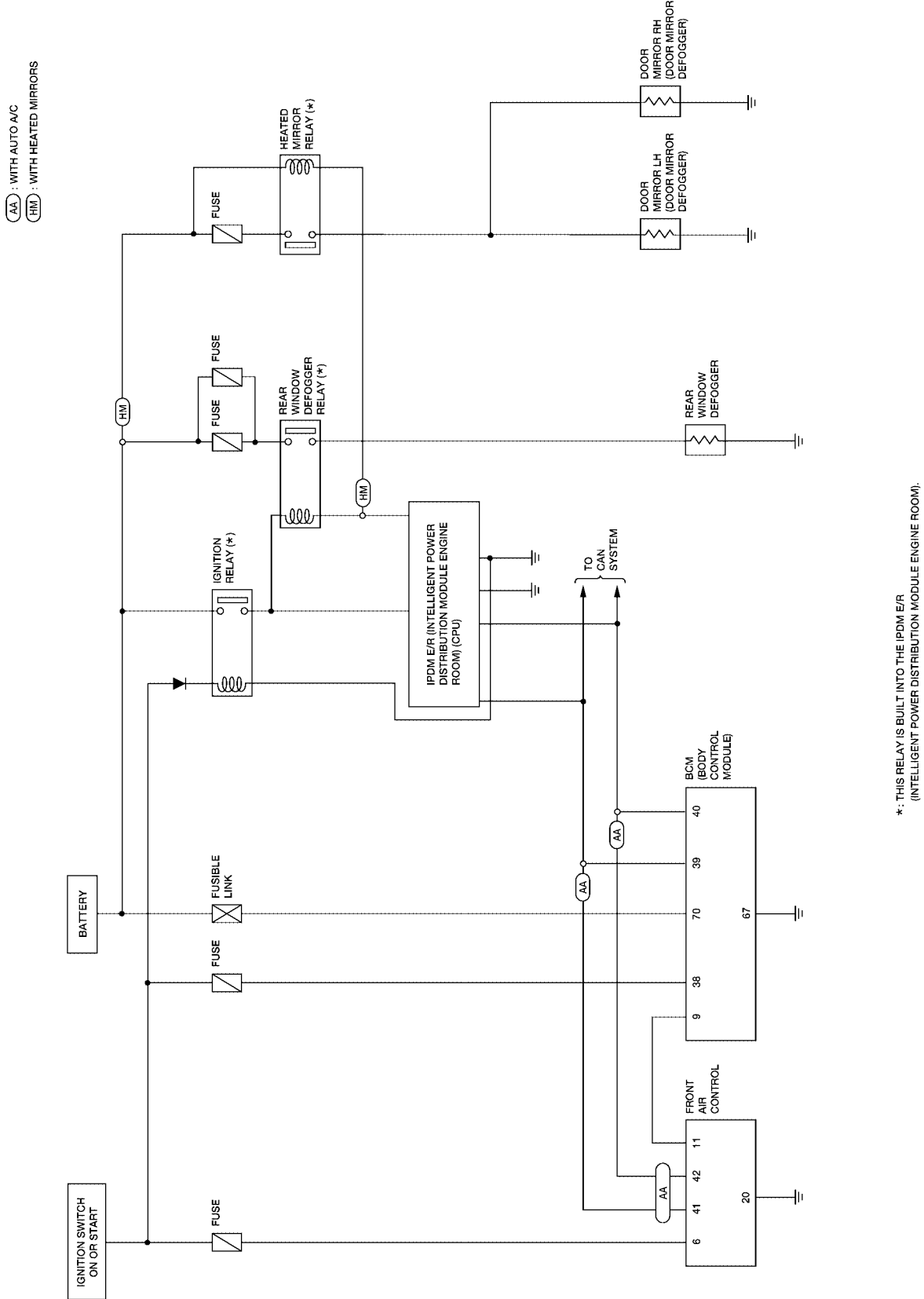

REAR WINDOW DEFOGGER

GW-DEF-02

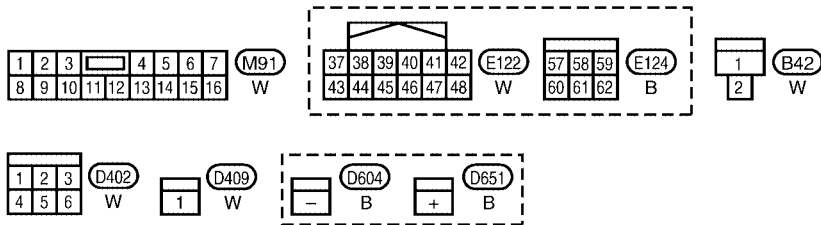
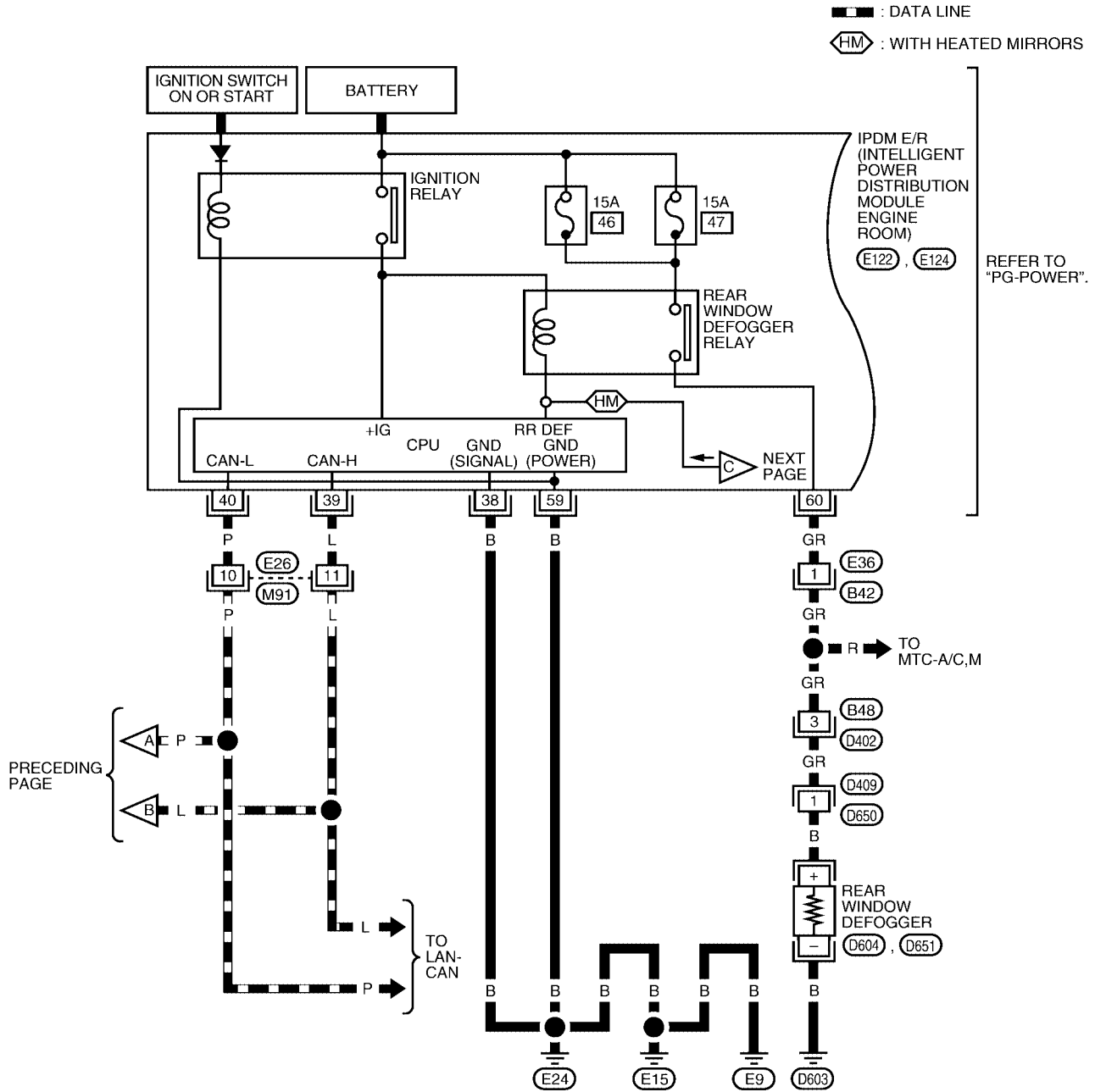

WIWA1608E

REAR WINDOW DEFOGGER

GW-DEF-03

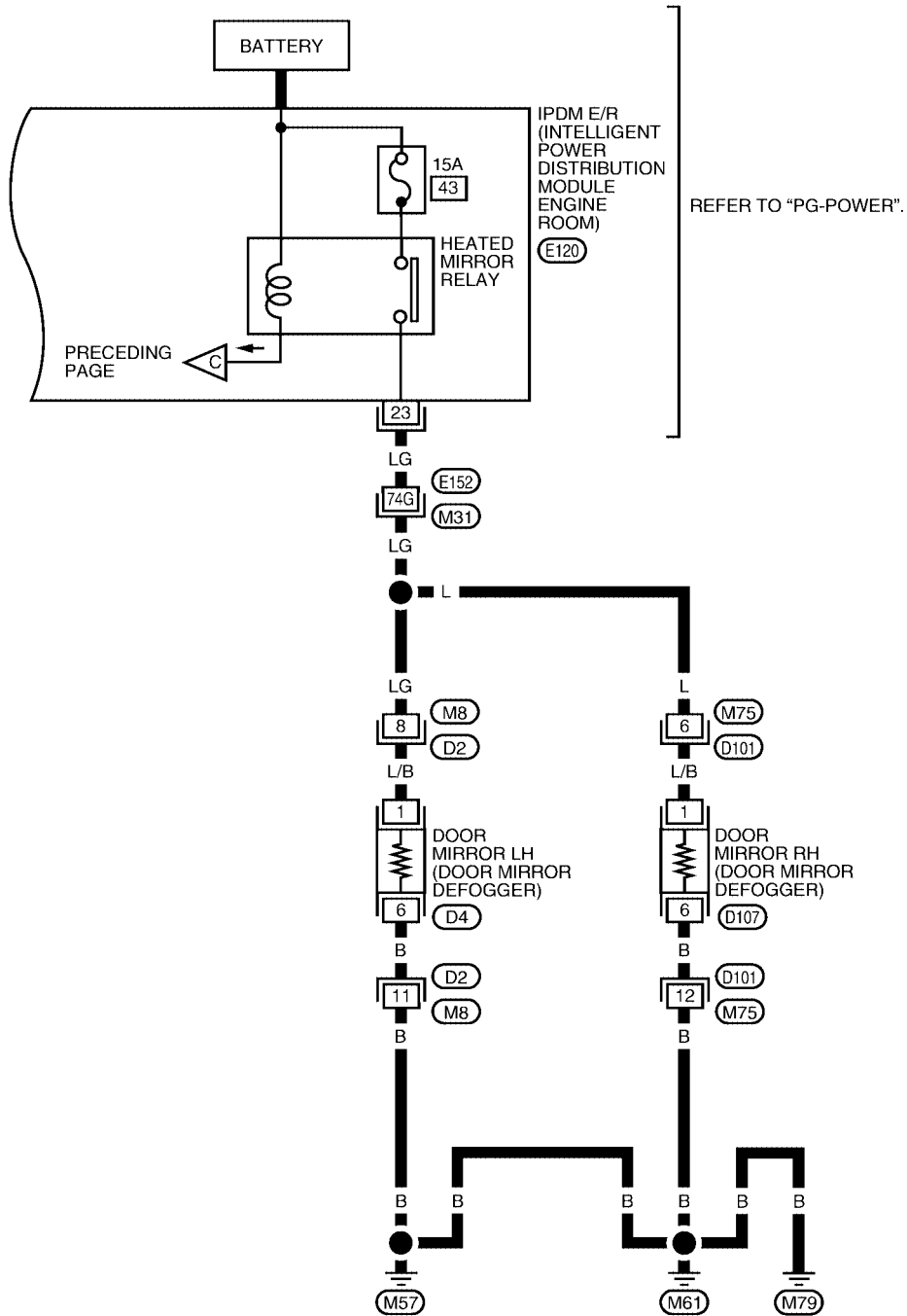

A
B
C
D
E
F
G
H
J
K
L
M

GW

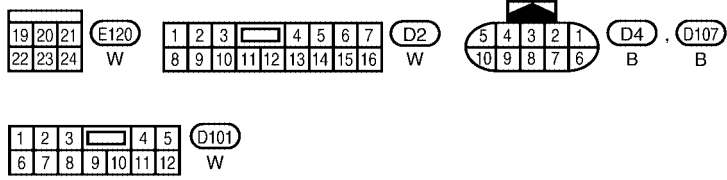

REFER TO THE FOLLOWING.
(M31) - SUPER MULTIPLE JUNCTION (SMJ)

W1WA0534E

REAR WINDOW DEFOGGER

Terminal and Reference Value for BCM

EIS007SD

Refer to [BCS-12, "Terminals and Reference Values for BCM"](#) .

Terminal and Reference Value for IPDM E/R

EIS007SE

Refer to [PG-18, "IPDM E/R \(INTELLIGENT POWER DISTRIBUTION MODULE ENGINE ROOM\)"](#) .

Work Flow

EIS007SF

1. Check the symptom and customer's requests.
2. Understand the outline of system. Refer to [GW-70, "System Description"](#) .
3. According to the trouble diagnosis chart, repair or replace the cause of the malfunction. Refer to [GW-78, "Trouble Diagnoses Symptom Chart"](#) .
4. Does rear window defogger operate normally? YES: GO TO 5, NO: GO TO 3.
5. Inspection End.

REAR WINDOW DEFOGGER

EIS007SG

CONSULT-II Function (BCM)

CONSULT-II can display each diagnostic item using the diagnostic test modes shown following.

BCM diagnostic test item	Diagnostic mode	Content
Inspection by part	WORK SUPPORT	Supports inspections and adjustments. Commands are transmitted to the BCM for setting the status suitable for required operation, input/output signals are received from the BCM and received data is displayed.
	DATA MONITOR	Displays BCM input/output data in real time.
	ACTIVE TEST	Operation of electrical loads can be checked by sending drive signal to them.
	SELF-DIAG RESULTS	Displays BCM self-diagnosis results.
	CAN DIAG SUPPORT MNTR	The results of transmit/receive diagnosis of CAN communication can be read.
	ECU PART NUMBER	BCM part number can be read.
	CONFIGURATION	Performs BCM configuration read/write functions.

CONSULT-II BASIC OPERATION PROCEDURE

CAUTION:

If CONSULT-II is used with no connection of CONSULT-II CONVERTER, malfunctions might be detected in self-diagnosis depending on control unit which carries out CAN communication.

1. Turn ignition switch OFF.
2. Connect CONSULT-II and CONSULT-II CONVERTER to data link connector.
3. Turn ignition switch ON.

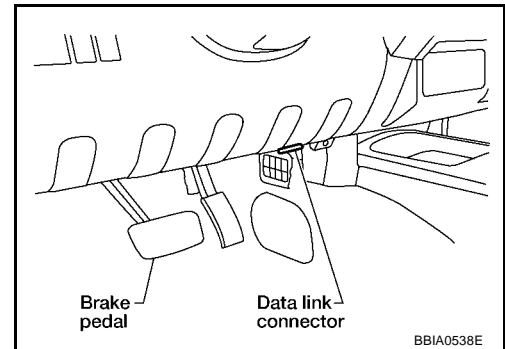

4. Touch "START (NISSAN BASED VHCL)".

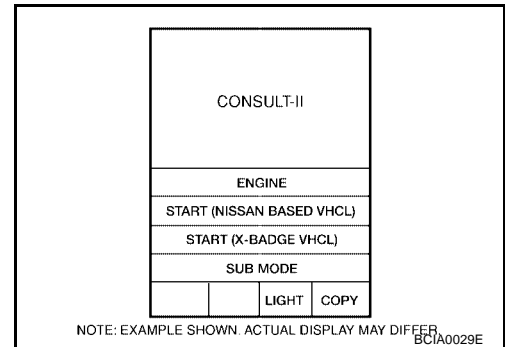

5. Touch "BCM".
If "BCM" is not indicated, go to [GI-40, "CONSULT-II Data Link Connector \(DLC\) Circuit"](#).

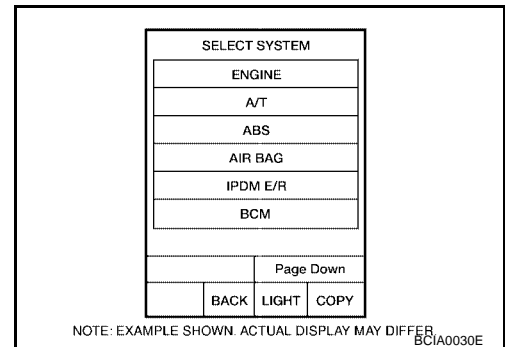

REAR WINDOW DEFOGGER

6. Touch "REAR DEFOGGER".

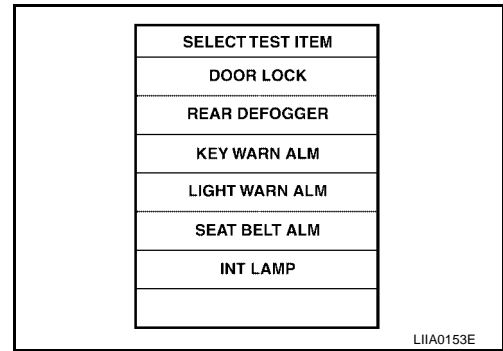

7. Select diagnosis mode, "DATA MONITOR" or "ACTIVE TEST".

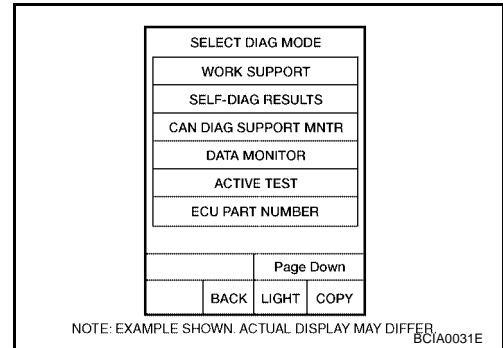

DATA MONITOR Display Item List

Monitor item "Operation"		Content
REAR DEF SW	"ON/OFF"	Displays "Press (ON)/others (OFF)" status determined with the rear window defogger switch.
IGN ON SW	"ON/OFF"	Displays "IGN (ON)/OFF" status determined with the ignition switch signal.

ACTIVE TEST Display Item List

Test item	Content
REAR WINDOW DEFOGGER	Gives a drive signal to the rear window defogger to activate it.

Trouble Diagnoses Symptom Chart

EIS007SH

- Make sure other systems using the signal of the following systems operate normally.

Symptom	Diagnoses / Service procedure	Refer to page
Rear window defogger and door mirror defoggers do not operate. (With heated mirrors)	1. BCM power supply and ground circuit check	GW-79
	2. IPDM E/R auto active test check	PG-24
	3. Rear window defogger switch circuit check	GW-79
	4. Replace IPDM E/R	PG-32
Rear window defogger does not operate. (Without heated mirrors)	1. BCM power supply and ground circuit check	GW-79
	2. IPDM E/R auto active test check	PG-24
	3. Rear window defogger switch circuit check	GW-79
	4. Rear window defogger circuit check	GW-80
	5. Filament check	GW-85
Rear window defogger does not operate but both door mirror defoggers operate. (With heated mirrors)	7. Replace IPDM E/R	PG-32
	1. Rear window defogger circuit check	GW-80
	2. Filament check	GW-85
	3. Replace IPDM E/R	PG-32

REAR WINDOW DEFOGGER

Symptom	Diagnoses / Service procedure	Refer to page
Both door mirror defoggers do not operate but rear window defogger operates. (With heated mirrors)	1. Door mirror defogger power supply circuit check	GW-81
	2. Replace IPDM E/R	PG-32
Door mirror LH defogger does not operate.	1. Door mirror LH defogger circuit check	GW-83
Door mirror RH defogger does not operate.	1. Door mirror RH defogger circuit check	GW-84
Rear window defogger switch does not light, but rear window defogger operates.	1. Rear window defogger signal check	GW-85

BCM Power Supply and Ground Circuit Check

EIS007SI

Refer to [BCS-16, "BCM Power Supply and Ground Circuit Check"](#) .

Rear Window Defogger Switch Circuit Check

EIS007SJ

1. CHECK REAR WINDOW DEFOGGER SWITCH OPERATION

④ With CONSULT-II

Check ("REAR DEF SW", "IGN ON SW") in DATA MONITOR mode with CONSULT-II.

When rear window defogger switch is turned to ON

REAR DEF SW : ON

When ignition switch is turned to ON

IGN ON SW : ON

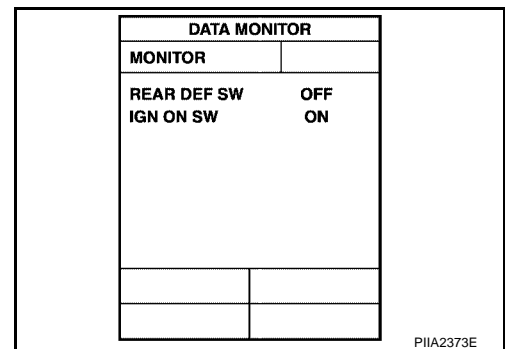

⊗ Without CONSULT-II

- Turn ignition switch ON.
- Check voltage between BCM connector and ground.

Connector	Terminals		Condition	Voltage (V) (Approx.)
	(+)	(-)		
M18	9	Ground	Rear window defogger switch is pressed.	0
			Rear window defogger switch is OFF.	5

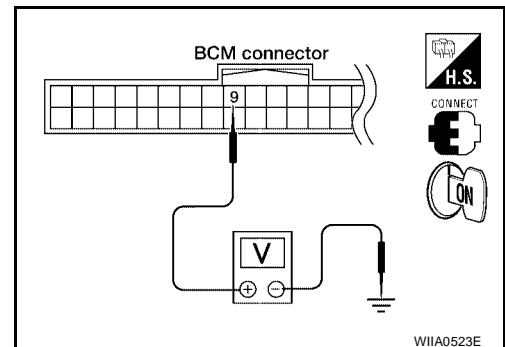

OK or NG

- OK >> Rear window defogger switch check is OK.
 NG >> GO TO 2.

REAR WINDOW DEFOGGER

2. CHECK REAR WINDOW DEFOGGER SWITCH CIRCUIT HARNESS CONTINUITY

1. Turn ignition switch OFF.
2. Disconnect BCM and front air control.
3. Check continuity between BCM connector M18 terminal 9 and front air control connector M49 terminal 11.

9 - 11 : Continuity should exist.

4. Check continuity between BCM connector M18 terminal 9 and ground

9 - Ground : Continuity should not exist.

OK or NG

- OK >> GO TO 3.
 NG >> Repair or replace harness.

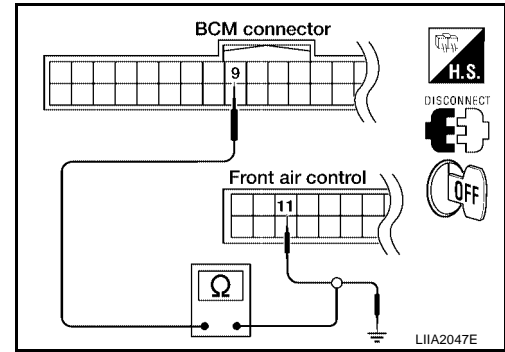

3. CHECK BCM OUTPUT SIGNAL

1. Connect BCM.
2. Turn ignition switch ON.
3. Check voltage between BCM connector M18 terminal 9 and ground.

9 - Ground : Approx. 5V

OK or NG

- OK >> Replace front air control. Refer to [ATC-25, "AIR CONDITIONER CONTROL"](#) .
 NG >> Replace BCM. Refer to [BCS-27, "Removal and Installation"](#) .

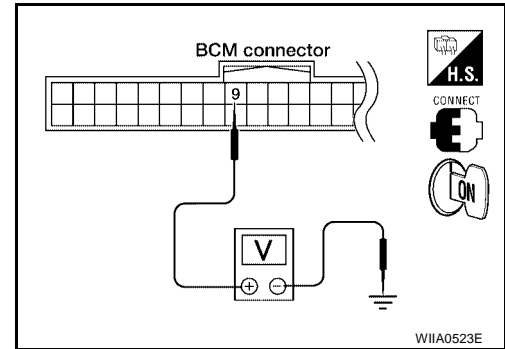

Rear Window Defogger Circuit Check

1. CHECK FUSES

Check if any of the following fuses in IPDM E/R are blown.

COMPONENT PARTS	AMPERE	FUSE NO.
IPDM E/R	15A	46
IPDM E/R	15A	47

NOTE:

Refer to [GW-70, "Component Parts and Harness Connector Location"](#) .

OK or NG

- OK >> GO TO 2.
 NG >> If fuse is blown, be sure to eliminate cause of malfunction before installing new fuse, refer to [GW-70, "Component Parts and Harness Connector Location"](#) .

REAR WINDOW DEFOGGER

2. CHECK REAR WINDOW DEFOGGER POWER SUPPLY CIRCUIT

1. Turn ignition switch OFF.
2. Disconnect rear window defogger.
3. Turn ignition switch ON.
4. Check voltage between rear window defogger connector D651 terminal + and ground.

Connector	Terminals		Condition	Voltage (V) (Approx.)
	(+)	(-)		
D651	+	Ground	Rear window defogger switch ON.	Battery voltage
			Rear window defogger switch OFF.	0

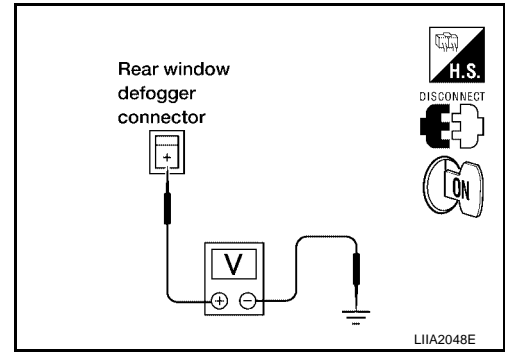

OK or NG

- OK >> GO TO 3.
NG >> GO TO 4.

3. CHECK REAR WINDOW DEFOGGER GROUND CIRCUIT

1. Turn ignition switch OFF.
2. Check continuity between rear window defogger connector D604 terminal - and ground.

- - **Ground** : **Continuity should exist.**

OK or NG

- OK >> Check filament. Refer to [GW-85, "Filament Check"](#).
- If filament is OK.
Check the condition of the harness and the connector.
 - If filament is NG.
Repair filament.
- NG >> Repair or replace harness.

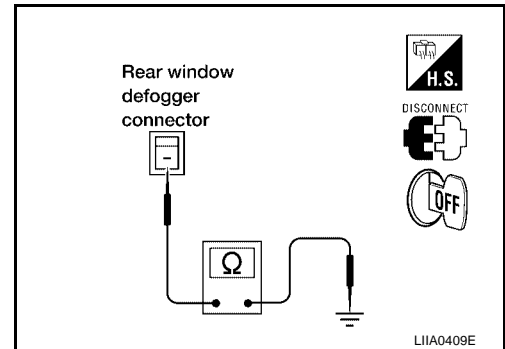

4. CHECK REAR WINDOW DEFOGGER RELAY OUTPUT SIGNAL

1. Turn ignition switch OFF.
2. Check voltage between IPDM E/R connector E124 terminal 60 and ground.

Connector	Terminals		Condition	Voltage (V) (Approx.)
	(+)	(-)		
E124	60	Ground	Rear window defogger switch ON.	Battery voltage
			Rear window defogger switch OFF.	0

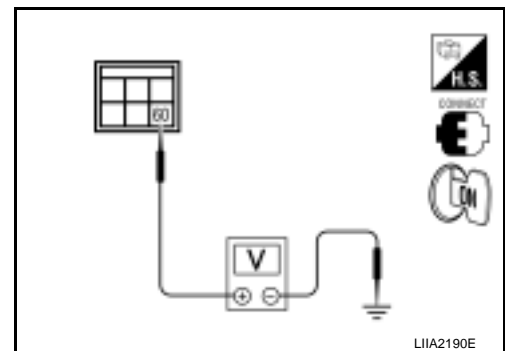

OK or NG

- OK >> Repair or replace harness.
NG >> Replace IPDM E/R. Refer to [PG-32, "Removal and Installation of IPDM E/R"](#).

Door Mirror Defogger Power Supply Circuit Check

EIS007SL

1. CHECK FUSE

Check if the following fuse in IPDM E/R is blown.

COMPONENT PARTS	AMPERE	FUSE NO.
IPDM E/R	15A	43

REAR WINDOW DEFOGGER

NOTE:

Refer to [GW-70, "Component Parts and Harness Connector Location"](#) .

OK or NG

OK >> GO TO 2.

NG >> If fuse is blown, be sure to eliminate cause of malfunction before installing new fuse. Refer to [GW-70, "Component Parts and Harness Connector Location"](#) .

2. CHECK DOOR MIRROR DEFOGGER POWER SUPPLY CIRCUIT

1. Turn ignition switch ON.
2. Check voltage between IPDM E/R connector and ground.

Connector	Terminals		Condition	Voltage (V) (Approx.)
	(+)	(-)		
E120	23	Ground	Rear window defogger switch ON	Battery voltage
			Rear window defogger switch OFF	0

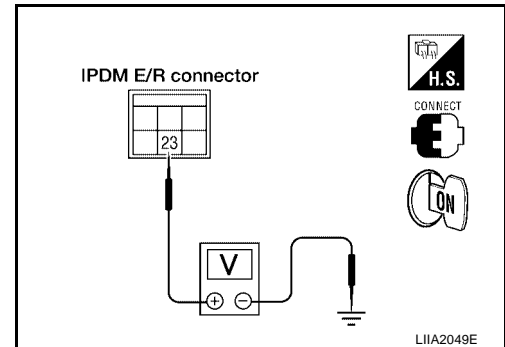

OK or NG

OK >> GO TO 3.

NG >> Replace IPDM E/R. Refer to [PG-32, "Removal and Installation of IPDM E/R"](#) .

3. CHECK DOOR MIRROR DEFOGGER CIRCUIT

1. Turn ignition switch OFF.
2. Disconnect IPDM E/R and door mirror LH or RH.
3. Check continuity between IPDM E/R connector and door mirror LH or RH connector.

Connector	Terminal	Connector	Terminal	Continuity
A		B		
IPDM E/R: E120	23	Door mirror: D4 (LH) or D107 (RH)	1	Yes

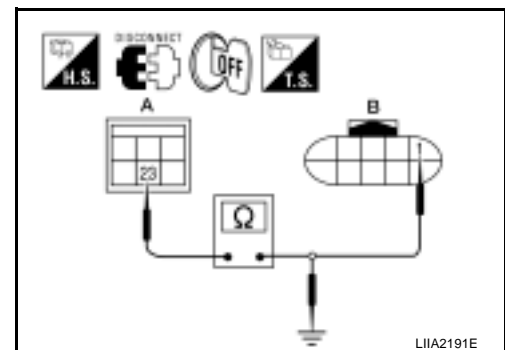

4. Check continuity between IPDM E/R and ground.

A		Ground	Continuity
Connector	Terminal		
IPDM E/R: E120	23		No

OK or NG

OK >> GO TO 4.

NG >> Repair or replace harness.

4. CHECK DOOR MIRROR DEFOGGER GROUND CIRCUIT

Check continuity between each door mirror connector D4 (LH) or D107 (RH) terminal 6 and ground.

6 - Ground : Continuity should exist.

OK or NG

OK >> GO TO 5.

NG >> Repair or replace harness.

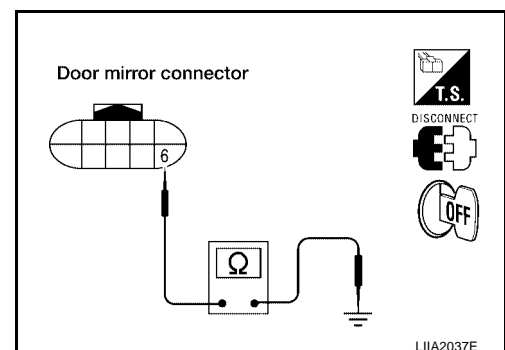

REAR WINDOW DEFOGGER

5. CHECK DOOR MIRROR DEFOGGER

Check continuity between each door mirror LH or RH terminals 1 and 6.

1 - 6 : Continuity should exist.

OK or NG

- OK >> Repair or replace harness.
- NG >> Replace malfunctioning door mirror LH or RH. Refer to [GW-90, "Door Mirror Assembly"](#).

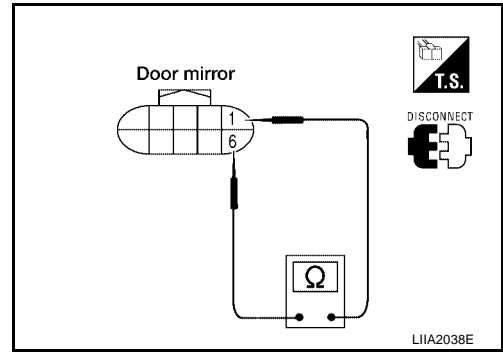

Door Mirror LH Defogger Circuit Check

1. CHECK DOOR MIRROR LH DEFOGGER POWER SUPPLY CIRCUIT

1. Turn ignition switch OFF.
2. Disconnect door mirror LH.
3. Turn ignition switch ON.
4. Check voltage between door mirror LH connector and ground.

Connector	Terminals		Condition	Voltage (V) (Approx.)
	(+)	(-)		
D4	1	Ground	Rear window defogger switch ON	Battery voltage
			Rear window defogger switch OFF	0

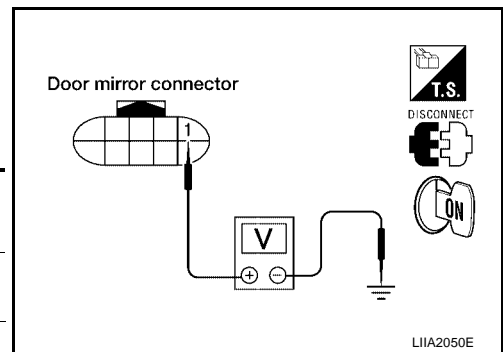

OK or NG

- OK >> GO TO 2.
- NG >> Repair or replace harness.

2. CHECK DOOR MIRROR LH DEFOGGER GROUND CIRCUIT

1. Turn ignition switch OFF.
2. Check continuity between door mirror LH connector D4 terminal 6 and ground.

6 - Ground : Continuity should exist.

OK or NG

- OK >> GO TO 3.
- NG >> Repair or replace harness.

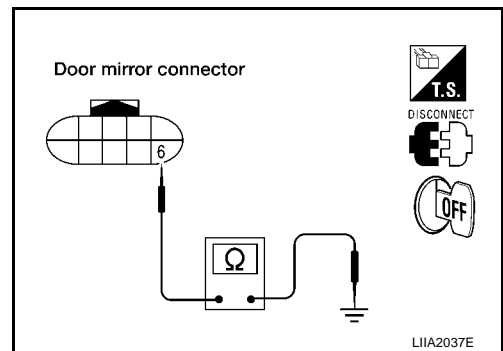

REAR WINDOW DEFOGGER

3. CHECK DOOR MIRROR LH DEFOGGER

Check continuity between door mirror LH terminals 1 and 6.

1 - 6 : Continuity should exist.

OK or NG

- OK >> Repair or replace harness.
- NG >> Replace door mirror LH. Refer to [GW-90, "Door Mirror Assembly"](#).

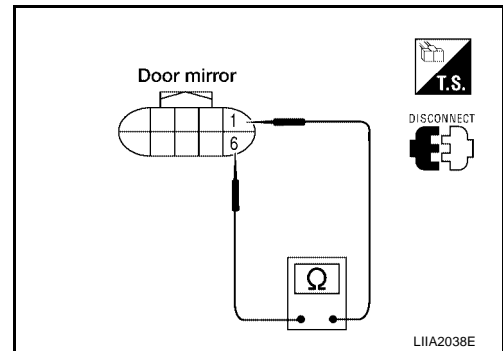

EIS007SN

Door Mirror RH Defogger Circuit Check

1. CHECK DOOR MIRROR RH DEFOGGER POWER SUPPLY CIRCUIT

1. Turn ignition switch OFF.
2. Disconnect door mirror RH.
3. Turn ignition switch ON.
4. Check voltage between door mirror RH connector and ground.

Connector	Terminals		Condition	Voltage (V) (Approx.)
	(+)	(-)		
D107	1	Ground	Rear window defogger switch ON	Battery voltage
			Rear window defogger switch OFF	0

OK or NG

- OK >> GO TO 2.
- NG >> Repair or replace harness.

2. CHECK DOOR MIRROR RH DEFOGGER GROUND CIRCUIT

1. Turn ignition switch OFF.
2. Check continuity between door mirror RH connector D107 terminal 6 and ground.

6 - Ground : Continuity should exist.

OK or NG

- OK >> GO TO 3.
- NG >> Repair or replace harness.

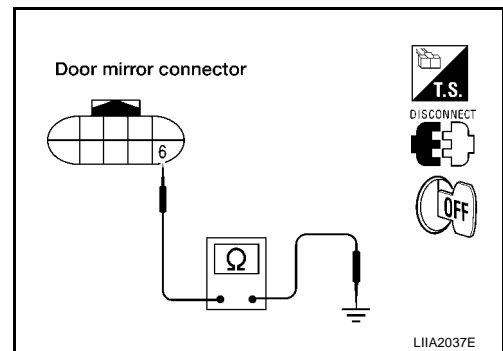
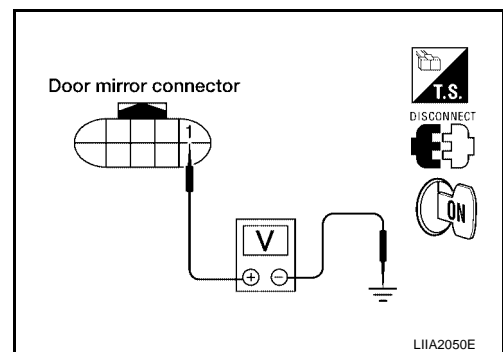

REAR WINDOW DEFOGGER

3. CHECK DOOR MIRROR RH DEFOGGER

Check continuity between each door mirror RH terminals 1 and 6.

1 - 6 : Continuity should exist.

OK or NG

- OK >> Repair or replace harness.
- NG >> Replace door mirror RH. Refer to [GW-90, "Door Mirror Assembly"](#).

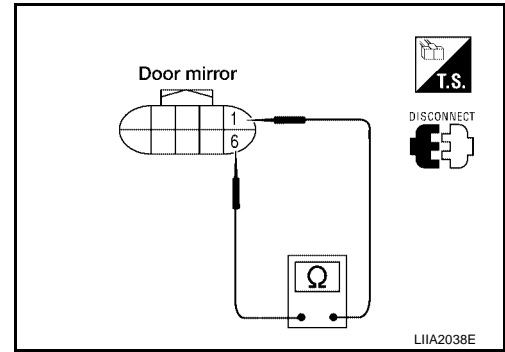

Rear Window Defogger Signal Check (With NAVI)

1. CHECK AV COMMUNICATION LINE

AV communication line check is executed. Refer to [ATC-33, "CAN Communication System Description"](#).

Is rear window defogger displayed on the display?

OK or NG

- OK >> GO TO 2.
- NG >> Replace display control unit. Refer to [AV-160, "DISPLAY UNIT"](#).

2. CHECK CAN COMMUNICATION LINE

CAN communication line check is executed. Refer to [LAN-25, "CAN COMMUNICATION"](#)

OK or NG

- OK >> Check the condition of the harness and the connector.
- NG >> In addition, it is necessary to check CAN communication line. Refer to [LAN-25, "CAN COMMUNICATION"](#).

Filament Check

1. When measuring voltage, wrap tin foil around the top of the negative probe. Then press the foil against the wire with your finger.

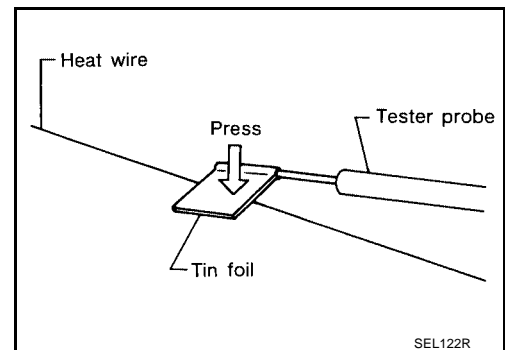

2. Attach probe circuit tester (in Volt range) to middle portion of each filament.

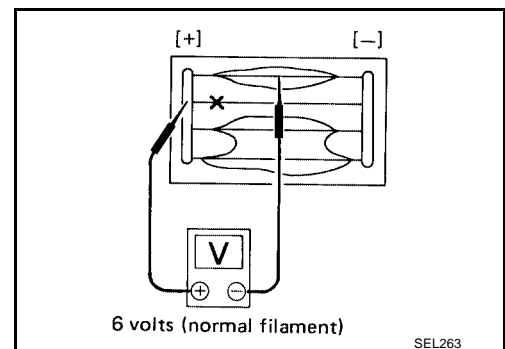

REAR WINDOW DEFOGGER

3. If a filament is burned out, circuit tester registers 0 or battery voltage.
4. To locate burned out point, move probe to left and right along filament. Test needle will swing abruptly when probe passes the point.

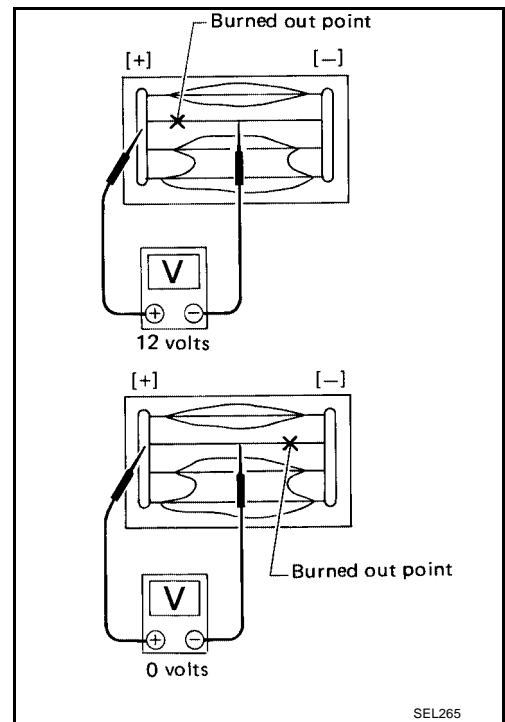

SEL265

EIS007SQ

Filament Repair REPAIR EQUIPMENT

- Conductive silver composition (DuPont No. 4817 or equivalent)
- Ruler 30 cm (11.8 in) long
- Drawing pen
- Heat gun
- Alcohol
- Cloth

REPAIRING PROCEDURE

1. Wipe broken heat wire and its surrounding area clean with a cloth dampened in alcohol.
2. Apply a small amount of conductive silver composition to tip of drawing pen. Shake silver composition container before use.
3. Place ruler on glass along broken line. Deposit conductive silver composition on break with drawing pen. Slightly overlap existing heat wire on both sides [preferably 5 mm (0.20 in)] of the break.

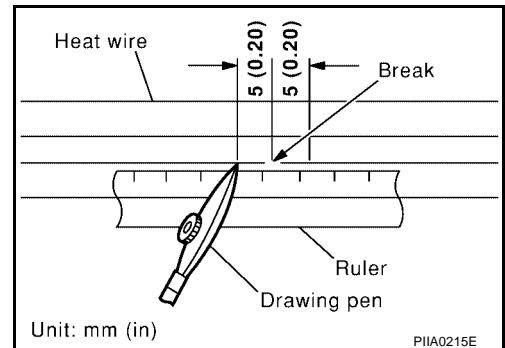

4. After repair has been completed, check repaired wire for continuity. This check should be conducted 10 minutes after silver composition is deposited. Do not touch repaired area while test is being conducted.

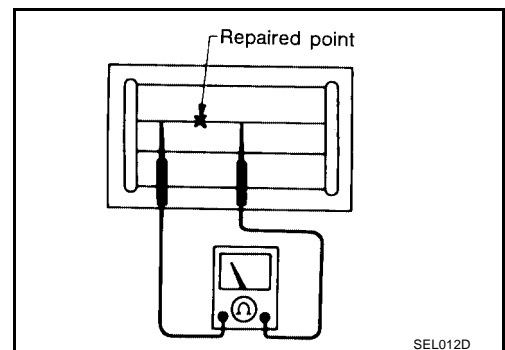

REAR WINDOW DEFOGGER

5. Apply a constant stream of hot air directly to the repaired area for approximately 20 minutes with a heat gun. A minimum distance of 3 cm (1.2 in) should be kept between repaired area and hot air outlet.
If a heat gun is not available, let the repaired area dry for 24 hours.

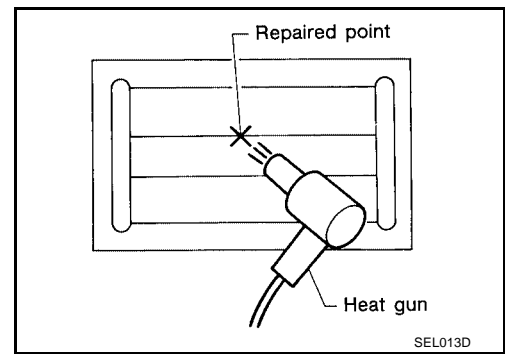

A
B
C
D
E
F
G
H
GW
J
K
L
M

DOOR MIRROR

PFP:96301

EIS007SR

DOOR MIRROR

Wiring Diagram — MIRROR —

WITHOUT HEATED MIRRORS

GW-MIRROR-01

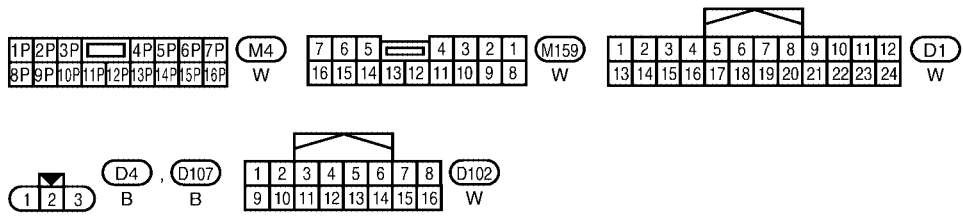
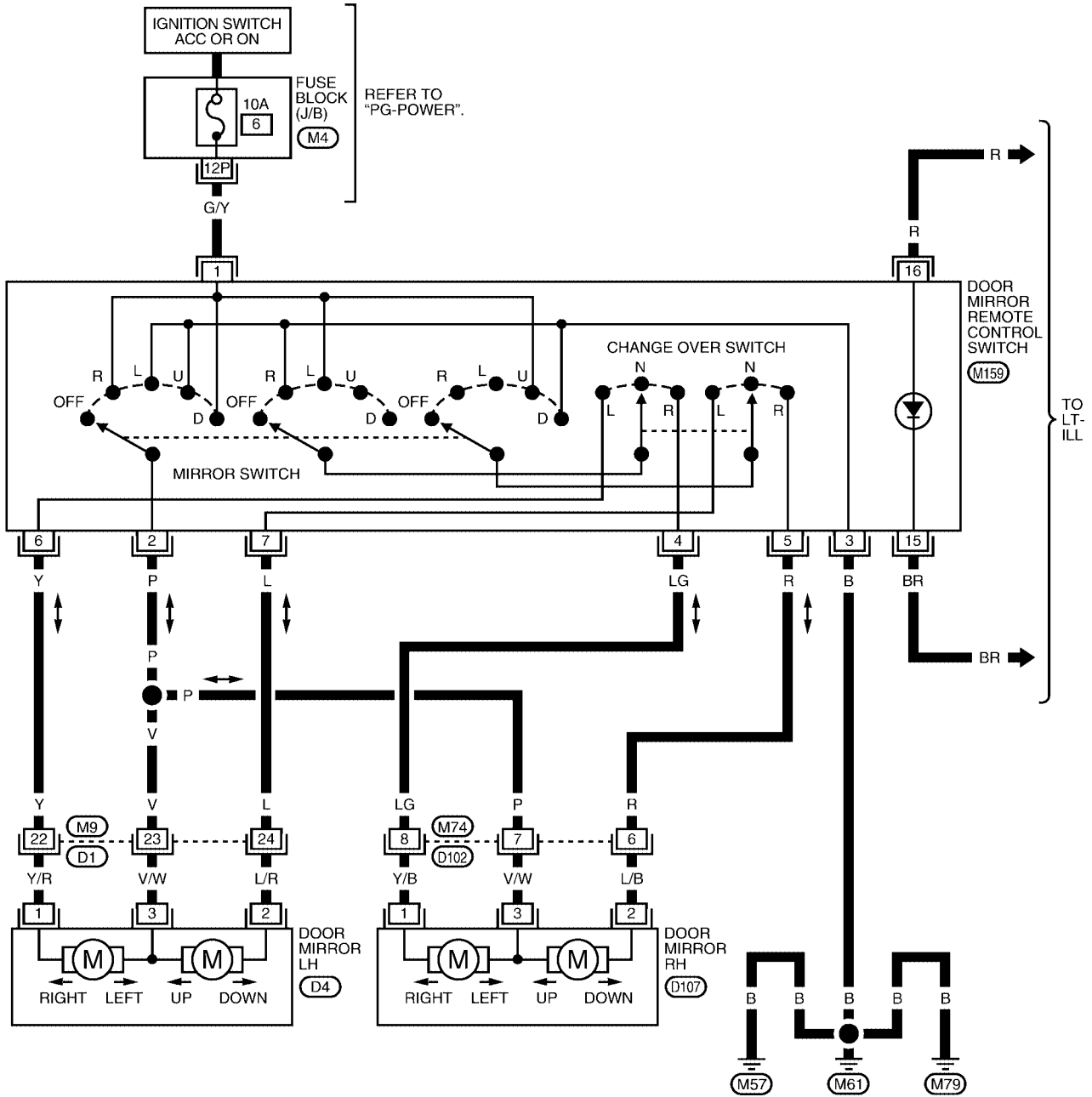

WIWA0536E

DOOR MIRROR

WITH HEATED MIRRORS

GW-MIRROR-02

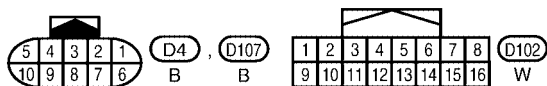
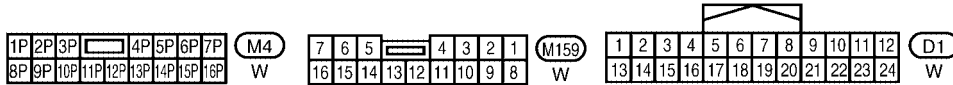
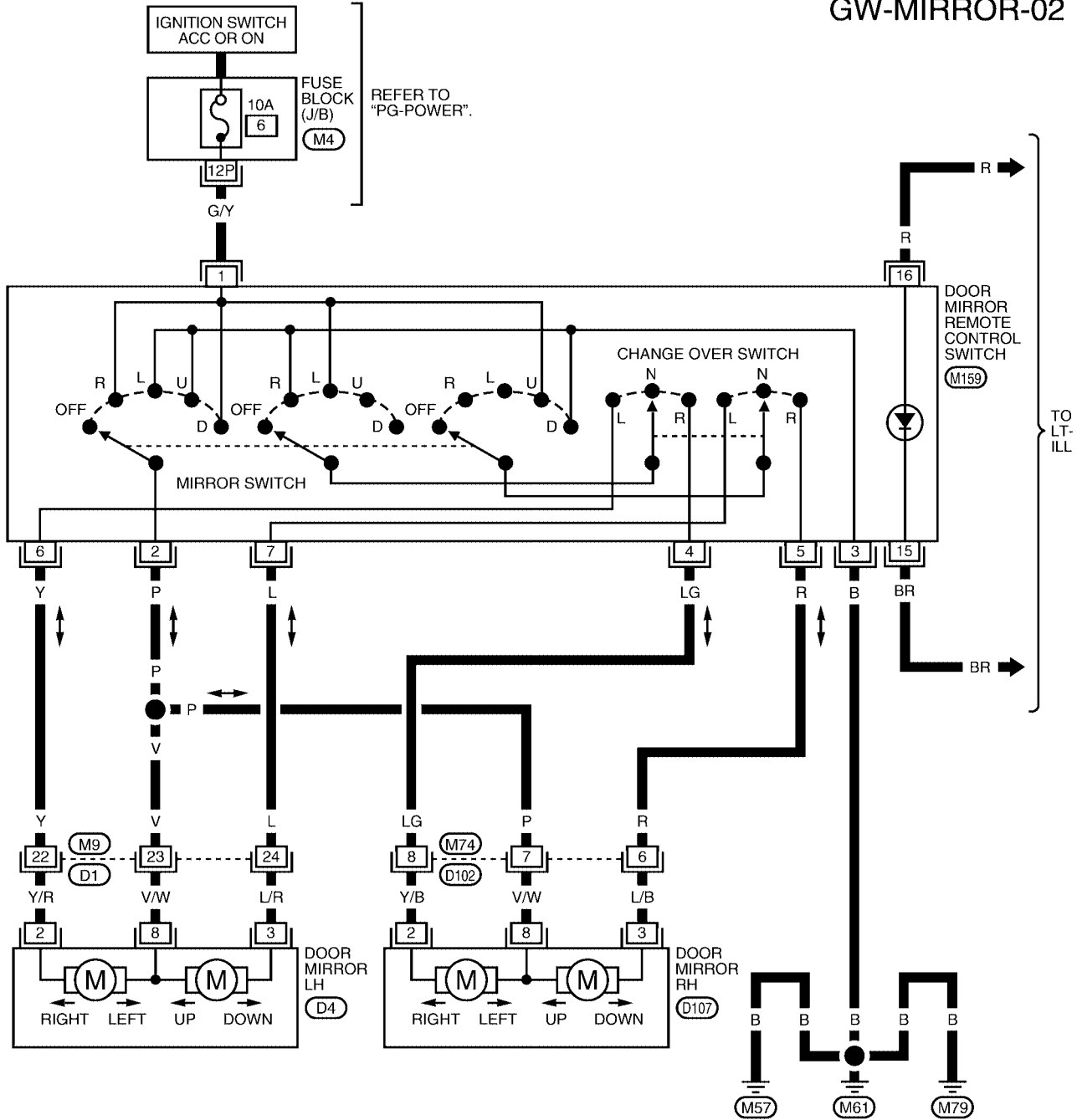

WIWA1044E

DOOR MIRROR

Door Mirror Assembly

EIS007SS

SEC. 963

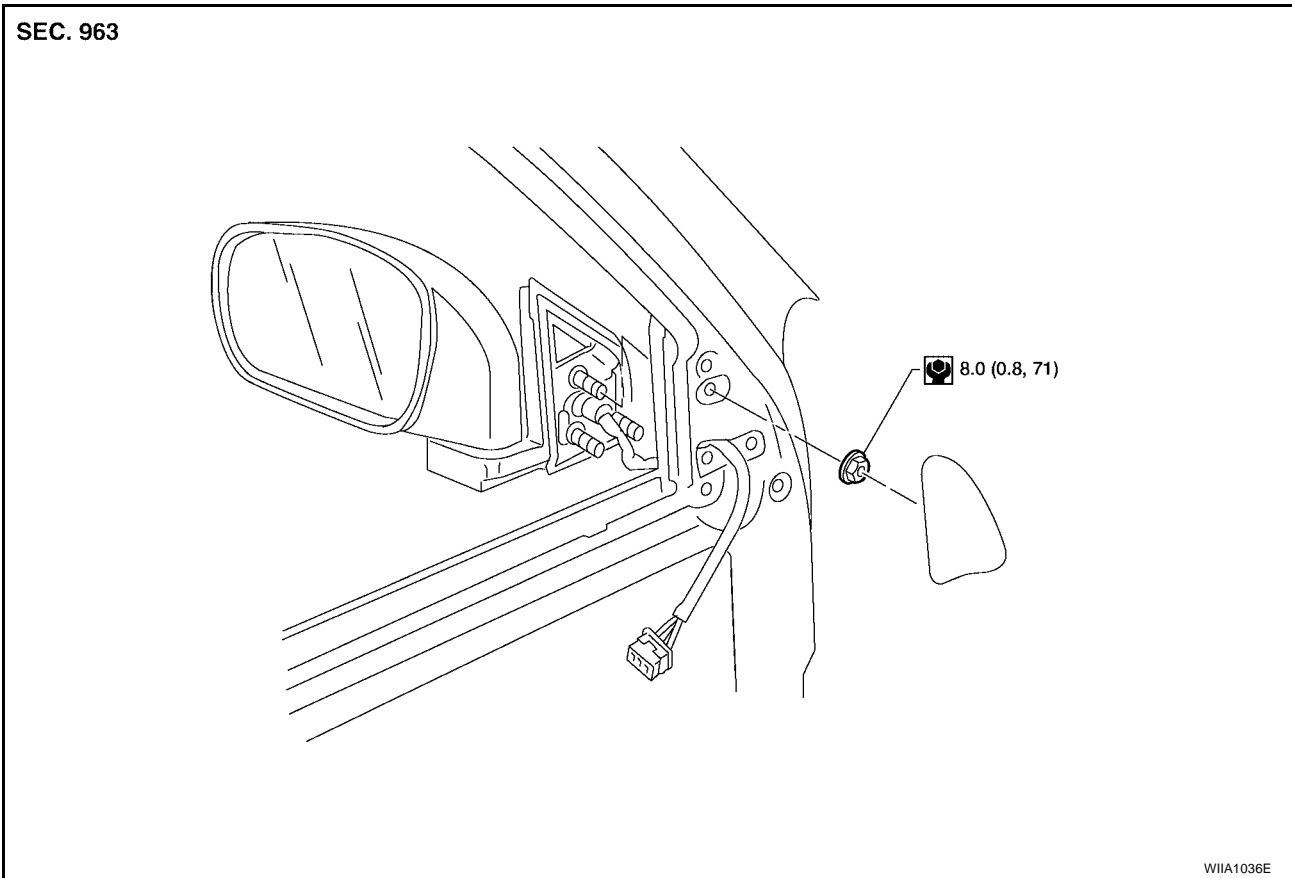

WI1A1036E

REMOVAL

NOTE:

Be careful not to damage the mirror bodies.

1. Remove the adhesive front door sash cover.
2. Remove the front door finisher. Refer to [EI-25, "FRONT DOOR"](#).
3. Position the front door seal aside.
4. Disconnect the door mirror harness connector.
5. Remove the nuts and the door mirror assembly.

INSTALLATION

Installation is in the reverse order of removal.

DOOR MIRROR

Door Mirror Glass REMOVAL AND INSTALLATION

EIS007ST

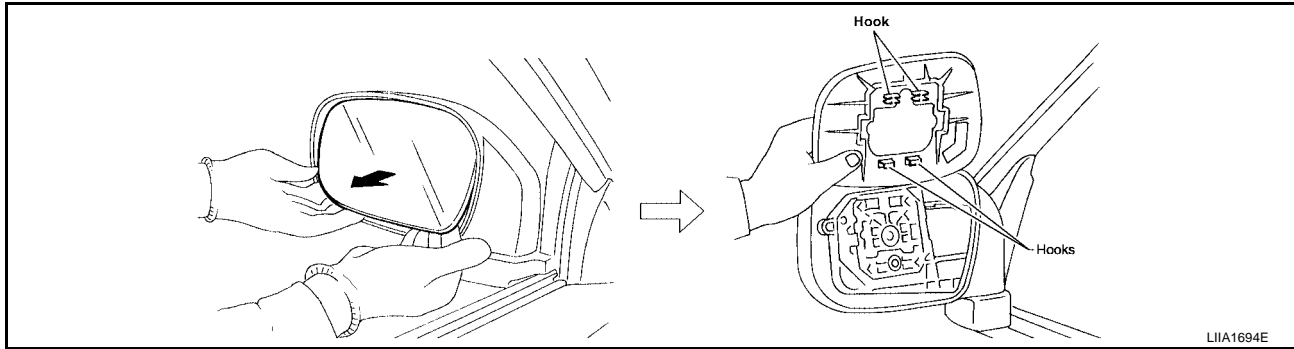

1. Angle the mirror fully up.
 2. Remove the mirror.
 - Pull from the bottom to disengage the clips.
 - Continue to pivot the mirror upward from the bottom to separate the hooks.
- Installation is in the reverse order of removal.

A
B
C
D
E
F
G
H
J
K
L
M

GW

DOOR MIRROR
