

SECTION **MTC**

MANUAL AIR CONDITIONER

A
B
C
D
E
F
G
H
I
J
K
L
M

CONTENTS

<p>PRECAUTIONS 4</p> <p> Precautions for Supplemental Restraint System (SRS) "AIR BAG" and "SEAT BELT PRE-TENSIONER" 4</p> <p> Precautions for Working with HFC-134a (R-134a).... 4</p> <p> Contaminated Refrigerant 4</p> <p> General Refrigerant Precautions 5</p> <p> Precautions for Leak Detection Dye 5</p> <p> A/C Identification Label 5</p> <p> Precautions for Refrigerant Connection 5</p> <p> FEATURES OF NEW TYPE REFRIGERANT CONNECTION 6</p> <p> O-RING AND REFRIGERANT CONNECTION..... 7</p> <p> Precautions for Servicing Compressor 9</p> <p> Precautions for Service Equipment 9</p> <p> RECOVERY/RECYCLING EQUIPMENT 9</p> <p> ELECTRONIC LEAK DETECTOR 9</p> <p> VACUUM PUMP 10</p> <p> MANIFOLD GAUGE SET 10</p> <p> SERVICE HOSES 10</p> <p> SERVICE COUPLERS 11</p> <p> REFRIGERANT WEIGHT SCALE 11</p> <p> CHARGING CYLINDER 11</p> <p>PREPARATION 12</p> <p> Special Service Tools 12</p> <p> HFC-134a (R-134a) Service Tools and Equipment.. 12</p> <p> Commercial Service Tools 15</p> <p>REFRIGERATION SYSTEM 16</p> <p> Components 16</p> <p> REFRIGERATION SYSTEM 16</p> <p> Refrigerant Cycle 17</p> <p> REFRIGERANT FLOW 17</p> <p> FREEZE PROTECTION 17</p> <p> Refrigerant System Protection 17</p> <p> REFRIGERANT PRESSURE SENSOR 17</p> <p> PRESSURE RELIEF VALVE 18</p> <p>OIL 19</p> <p> Maintenance of Oil Quantity in Compressor 19</p> <p> OIL 19</p> <p> CHECKING AND ADJUSTING 19</p>	<p>AIR CONDITIONER CONTROL 22</p> <p> Description 22</p> <p> Operation 22</p> <p> AIR MIX DOOR CONTROL 22</p> <p> BLOWER SPEED CONTROL 22</p> <p> INTAKE DOORS CONTROL 22</p> <p> MODE DOOR CONTROL 22</p> <p> DEFROSTER DOOR CONTROL 22</p> <p> MAGNET CLUTCH CONTROL 22</p> <p> Description of Control System 24</p> <p> Control Operation 25</p> <p> TEMPERATURE CONTROL DIAL (TEMPERATURE CONTROL) 25</p> <p> RECIRCULATION () SWITCH 25</p> <p> DEFROSTER () SWITCH 25</p> <p> REAR WINDOW DEFOGGER SWITCH 25</p> <p> OFF SWITCH (BLOWER SPEED SET TO 0) 25</p> <p> A/C SWITCH 25</p> <p> MODE DIAL 25</p> <p> FRONT BLOWER CONTROL DIAL 25</p> <p> Discharge Air Flow 26</p> <p> FRONT 26</p> <p> System Description 27</p> <p> SWITCHES AND THEIR CONTROL FUNCTION.. 27</p> <p> CAN Communication System Description 28</p> <p>TROUBLE DIAGNOSIS 29</p> <p> CONSULT-II Function (BCM) 29</p> <p> CONSULT-II BASIC OPERATION 29</p> <p> DATA MONITOR 30</p> <p> How to Perform Trouble Diagnosis for Quick and Accurate Repair 31</p> <p> WORK FLOW 31</p> <p> SYMPTOM TABLE 31</p> <p> Component Parts and Harness Connector Location.. 32</p> <p> ENGINE COMPARTMENT 32</p> <p> PASSENGER COMPARTMENT 33</p> <p> Schematic 34</p> <p> Wiring Diagram — A/C,M — 35</p> <p> Front Air Control Terminals and Reference Value... 39</p> <p> PIN CONNECTOR TERMINAL LAYOUT 39</p>
---	---

MTC

TERMINALS AND REFERENCE VALUE FOR	SOR	80
FRONT AIR CONTROL	COMPONENT INSPECTION	81
Operational Check	CONTROL UNIT	82
CHECKING BLOWER	Removal and Installation	82
CHECKING DISCHARGE AIR	FRONT AIR CONTROL	82
DISCHARGE AIR FLOW	INTAKE SENSOR	83
CHECKING RECIRCULATION	Removal and Installation	83
CHECKING TEMPERATURE DECREASE	REMOVAL	83
CHECKING TEMPERATURE INCREASE	INSTALLATION	83
CHECK A/C SWITCH	BLOWER MOTOR	84
Power Supply and Ground Circuit for Front Air Control	Components	84
INSPECTION FLOW	Removal and Installation	84
COMPONENT DESCRIPTION	REMOVAL	84
DIAGNOSTIC PROCEDURE FOR A/C SYSTEM	INSTALLATION	84
Mode Door Motor Circuit	IN-CABIN MICROFILTER	85
INSPECTION FLOW	Removal and Installation	85
SYSTEM DESCRIPTION	FUNCTION	85
COMPONENT DESCRIPTION	REPLACEMENT TIMING	85
DIAGNOSTIC PROCEDURE FOR MODE	REPLACEMENT PROCEDURE	85
DOOR MOTOR	HEATER & COOLING UNIT ASSEMBLY	87
Air Mix Door Motor Circuit	Components	87
INSPECTION FLOW	Removal and Installation	87
SYSTEM DESCRIPTION	REMOVAL	87
COMPONENT DESCRIPTION	INSTALLATION	88
DIAGNOSTIC PROCEDURE FOR AIR MIX	HEATER CORE	89
DOOR MOTOR (FRONT)	Components	89
Intake Door Motor Circuit	Removal and Installation	89
INSPECTION FLOW	REMOVAL	89
SYSTEM DESCRIPTION	INSTALLATION	89
COMPONENT DESCRIPTION	INTAKE DOOR MOTOR	90
DIAGNOSTIC PROCEDURE FOR INTAKE	Removal and Installation	90
DOOR MOTOR	REMOVAL	90
Front Blower Motor Circuit	INSTALLATION	90
INSPECTION FLOW	MODE DOOR MOTOR	91
SYSTEM DESCRIPTION	Removal and Installation	91
COMPONENT DESCRIPTION	REMOVAL	91
DIAGNOSTIC PROCEDURE FOR BLOWER	INSTALLATION	91
MOTOR	AIR MIX DOOR MOTOR	92
COMPONENT INSPECTION	Components	92
Magnet Clutch Circuit	Removal and Installation	92
INSPECTION FLOW	REMOVAL	92
SYSTEM DESCRIPTION	INSTALLATION	92
DIAGNOSTIC PROCEDURE FOR MAGNET	FRONT BLOWER MOTOR RESISTOR	93
CLUTCH	Removal and Installation	93
Insufficient Cooling	REMOVAL	93
INSPECTION FLOW	INSTALLATION	93
PERFORMANCE TEST DIAGNOSES	DUCTS AND GRILLES	94
PERFORMANCE CHART	Components	94
TROUBLE DIAGNOSES FOR UNUSUAL PRES-	Removal and Installation	95
SURE	CONSOLE DUCTS AND CONSOLE GRILLE	95
Insufficient Heating	DEFROSTER NOZZLE	96
INSPECTION FLOW	RH AND LH SIDE DEMISTER DUCTS	96
Noise	RH AND LH VENTILATOR DUCTS	96
INSPECTION FLOW	CENTER VENTILATOR DUCT	96
Intake Sensor Circuit	FLOOR CONNECTOR DUCT	96
COMPONENT DESCRIPTION	FRONT AND REAR FLOOR DUCTS	96
DIAGNOSTIC PROCEDURE FOR INTAKE SEN-	GRILLES	97
	REFRIGERANT LINES	98
	HFC-134a (R-134a) Service Procedure	98

SETTING OF SERVICE TOOLS AND EQUIPMENT	98	Sensor	106	
Components	100	REMOVAL	106	A
Removal and Installation for Compressor	101	INSTALLATION	106	
COMPONENTS	101	Removal and Installation for Condenser	106	
REMOVAL	101	REMOVAL	106	B
INSTALLATION	101	INSTALLATION	107	
Removal and Installation for Compressor Clutch	102	Removal and Installation for Evaporator	108	
REMOVAL	102	REMOVAL	109	C
INSPECTION	103	INSTALLATION	109	
INSTALLATION	103	Removal and Installation for Expansion Valve	109	
BREAK-IN OPERATION	105	REMOVAL	109	D
Removal and Installation for High-pressure Flexible		INSTALLATION	109	
A/C Hose	105	Checking for Refrigerant Leaks	109	
REMOVAL	105	Checking System for Leaks Using the Fluorescent		
INSTALLATION	105	Dye Leak Detector	109	E
Removal and Installation for High-pressure A/C		Dye Injection	110	
Pipe	105	Electronic Refrigerant Leak Detector	110	
REMOVAL	105	PRECAUTIONS FOR HANDLING LEAK		F
INSTALLATION	105	DETECTOR	110	
Removal and Installation for Low-pressure Flexible		CHECKING PROCEDURE	111	
A/C Hose	105	SERVICE DATA AND SPECIFICATIONS (SDS) ... 113		G
REMOVAL	105	Service Data and Specifications (SDS)	113	
INSTALLATION	105	COMPRESSOR	113	
Removal and Installation for Low-pressure A/C Pipe	106	OIL	113	
REMOVAL	106	REFRIGERANT	113	H
INSTALLATION	106	ENGINE IDLING SPEED	113	
Removal and Installation for Refrigerant Pressure		BELT TENSION	113	I

MTC

K
L
M

PRECAUTIONS

PRECAUTIONS

PFP:00001

Precautions for Supplemental Restraint System (SRS) “AIR BAG” and “SEAT BELT PRE-TENSIONER”

EJS004QR

The Supplemental Restraint System such as “AIR BAG” and “SEAT BELT PRE-TENSIONER”, used along with a front seat belt, helps to reduce the risk or severity of injury to the driver and front passenger for certain types of collision. This system includes seat belt switch inputs and dual stage front air bag modules. The SRS system uses the seat belt switches to determine the front air bag deployment, and may only deploy one front air bag, depending on the severity of a collision and whether the front occupants are belted or unbelted. Information necessary to service the system safely is included in the SRS and SB section of this Service Manual.

WARNING:

- To avoid rendering the SRS inoperative, which could increase the risk of personal injury or death in the event of a collision which would result in air bag inflation, all maintenance must be performed by an authorized NISSAN/INFINITI dealer.
- Improper maintenance, including incorrect removal and installation of the SRS, can lead to personal injury caused by unintentional activation of the system. For removal of Spiral Cable and Air Bag Module, see the SRS section.
- Do not use electrical test equipment on any circuit related to the SRS unless instructed to in this Service Manual. SRS wiring harnesses can be identified by yellow and/or orange harnesses or harness connectors.

Precautions for Working with HFC-134a (R-134a)

EJS004QS

WARNING:

- CFC-12 (R-12) refrigerant and HFC-134a (R-134a) refrigerant are not compatible. If the refrigerants are mixed compressor failure is likely to occur. Refer [MTC-4, "Contaminated Refrigerant"](#). To determine the purity of HFC-134a (R-134a) in the vehicle and recovery tank, use Refrigerant Recovery/Recycling Recharging equipment and Refrigerant Identifier.
- Use only specified oil for the HFC-134a (R-134a) A/C system and HFC-134a (R-134a) components. If oil other than that specified is used, compressor failure is likely to occur.
- The specified HFC-134a (R-134a) oil rapidly absorbs moisture from the atmosphere. The following handling precautions must be observed:
 - When removing refrigerant components from a vehicle, immediately cap (seal) the component to minimize the entry of moisture from the atmosphere.
 - When installing refrigerant components to a vehicle, do not remove the caps (unseal) until just before connecting the components. Connect all refrigerant loop components as quickly as possible to minimize the entry of moisture into system.
 - Only use the specified oil from a sealed container. Immediately reseal containers of oil. Without proper sealing, oil will become moisture saturated and should not be used.
 - Avoid breathing A/C refrigerant and oil vapor or mist. Exposure may irritate eyes, nose and throat. Remove HFC-134a (R-134a) from the A/C system using certified service equipment meeting requirements of SAE J2210 [HFC-134a (R-134a) recycling equipment], or SAE J2209 [HFC-134a (R-134a) recovery equipment]. If accidental system discharge occurs, ventilate work area before resuming service. Additional health and safety information may be obtained from refrigerant and oil manufacturers.
 - Do not allow the refrigerant oil to come in contact with styrofoam parts. Damage may result.

Contaminated Refrigerant

EJS004QT

If a refrigerant other than pure HFC-134a (R-134a) is identified in a vehicle, your options are:

- Explain to the customer that environmental regulations prohibit the release of contaminated refrigerant into the atmosphere.
- Explain that recovery of the contaminated refrigerant could damage your service equipment and refrigerant supply.
- Suggest the customer return the vehicle to the location of previous service where the contamination may have occurred.
- If you choose to perform the repair, recover the refrigerant using only **dedicated equipment and containers. Do not recover contaminated refrigerant into your existing service equipment.** If your facility

PRECAUTIONS

does not have dedicated recovery equipment, you may contact a local refrigerant product retailer for available service. This refrigerant must be disposed of in accordance with all federal and local regulations. In addition, replacement of all refrigerant system components on the vehicle is recommended.

- If the vehicle is within the warranty period, the air conditioner warranty is void. Please contact NISSAN Customer Affairs for further assistance.

General Refrigerant Precautions

EJS004QU

WARNING:

- Do not release refrigerant into the air. Use approved recovery/recycling equipment to capture the refrigerant every time an air conditioning system is discharged.
- Always wear eye and hand protection (goggles and gloves) when working with any refrigerant or air conditioning system.
- Do not store or heat refrigerant containers above 52°C (125°F).
- Do not heat a refrigerant container with an open flame; if container warming is required, place the bottom of the container in a warm pail of water.
- Do not intentionally drop, puncture, or incinerate refrigerant containers.
- Keep refrigerant away from open flames: poisonous gas will be produced if refrigerant burns.
- Refrigerant will displace oxygen, therefore be certain to work in well ventilated areas to prevent suffocation.
- Do not pressure test or leak test HFC-134a (R-134a) service equipment and/or vehicle air conditioning systems with compressed air during repair. Some mixtures of air and HFC-134a (R-134a) have been shown to be combustible at elevated pressures. These mixtures, if ignited, may cause injury or property damage. Additional health and safety information may be obtained from refrigerant manufacturers.

Precautions for Leak Detection Dye

EJS004QV

- The A/C system contains a fluorescent leak detection dye used for locating refrigerant leaks. An ultraviolet (UV) lamp is required to illuminate the dye when inspecting for leaks.
- Always wear fluorescence enhancing UV safety goggles to protect your eyes and enhance the visibility of the fluorescent dye.
- The fluorescent dye leak detector is not a replacement for an electronic refrigerant leak detector. The fluorescent dye leak detector should be used in conjunction with an electronic refrigerant leak detector (J-41995).
- For your safety and the customer's satisfaction, read and follow all manufacturer's operating instructions and precautions prior to performing work.
- A compressor shaft seal should not be repaired because of dye seepage. The compressor shaft seal should only be repaired after confirming the leak with an electronic refrigerant leak detector (J-41995).
- Always remove any remaining dye from the leak area after repairs are complete to avoid a misdiagnosis during a future service.
- Do not allow dye to come into contact with painted body panels or interior components. If dye is spilled, clean immediately with the approved dye cleaner. Fluorescent dye left on a surface for an extended period of time **cannot be removed**.
- Do not spray the fluorescent dye cleaning agent on hot surfaces (engine exhaust manifold, etc.).
- Do not use more than one refrigerant dye bottle (1/4 ounce / 7.4 cc) per A/C system.
- Leak detection dyes for HFC-134a (R-134a) and CFC-12 (R-12) A/C systems are different. Do not use HFC-134a (R-134a) leak detection dye in CFC-12 (R-12) A/C systems or CFC-12 (R-12) leak detection dye in HFC-134a (R-134a) A/C systems or A/C system damage may result.
- The fluorescent properties of the dye will remain for over three (3) years unless a compressor failure occurs.

A/C Identification Label

EJS004QW

Vehicles with factory installed fluorescent dye have this identification label on the underside of hood.

Precautions for Refrigerant Connection

EJS004QX

A new type refrigerant connection has been introduced to all refrigerant lines except the following locations.

A
B
C
D
E
F
G
H

MTC

K
L
M

PRECAUTIONS

- Expansion valve to cooling unit
- Evaporator pipes to evaporator (inside cooling unit)
- Refrigerant pressure sensor

FEATURES OF NEW TYPE REFRIGERANT CONNECTION

- The O-ring has been relocated. It has also been provided with a groove for proper installation. This reduces the possibility of the O-ring being caught in, or damaged by, the mating part. The sealing direction of the O-ring is now set vertically in relation to the contacting surface of the mating part to improve sealing characteristics.
- The reaction force of the O-ring will not occur in the direction that causes the joint to pull out, thereby facilitating piping connections.

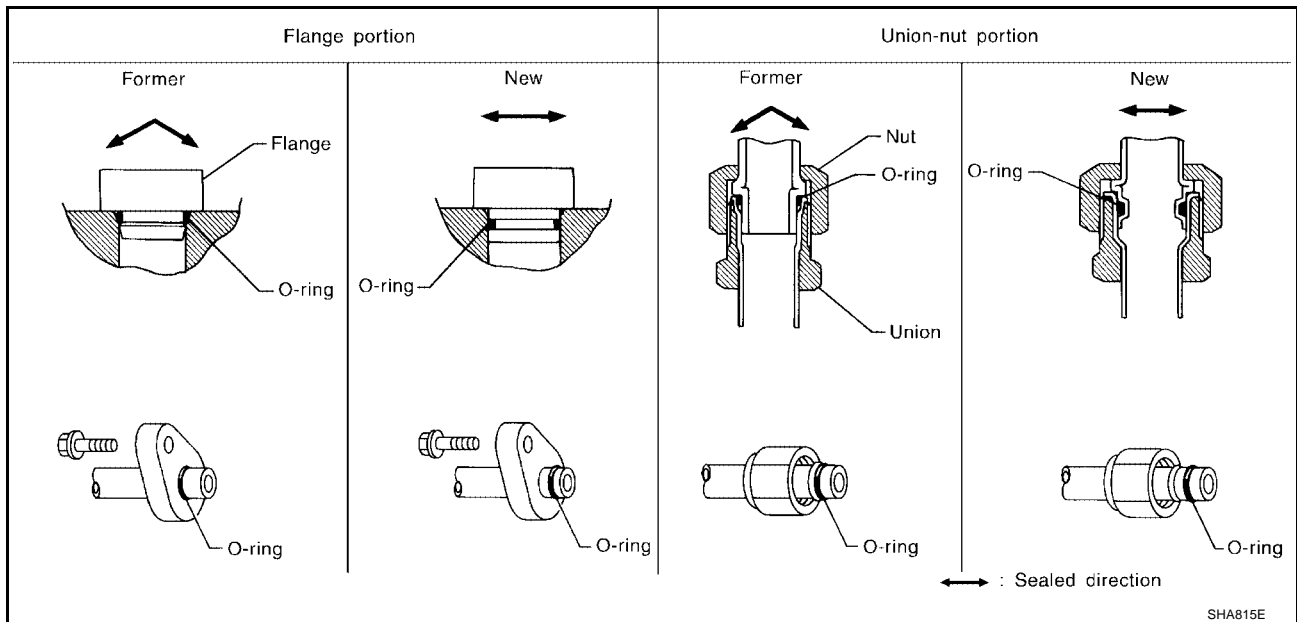

PRECAUTIONS

O-RING AND REFRIGERANT CONNECTION

A/C Compressor and Condenser

SEC. 270 • 271 • 274 • 276 • 278

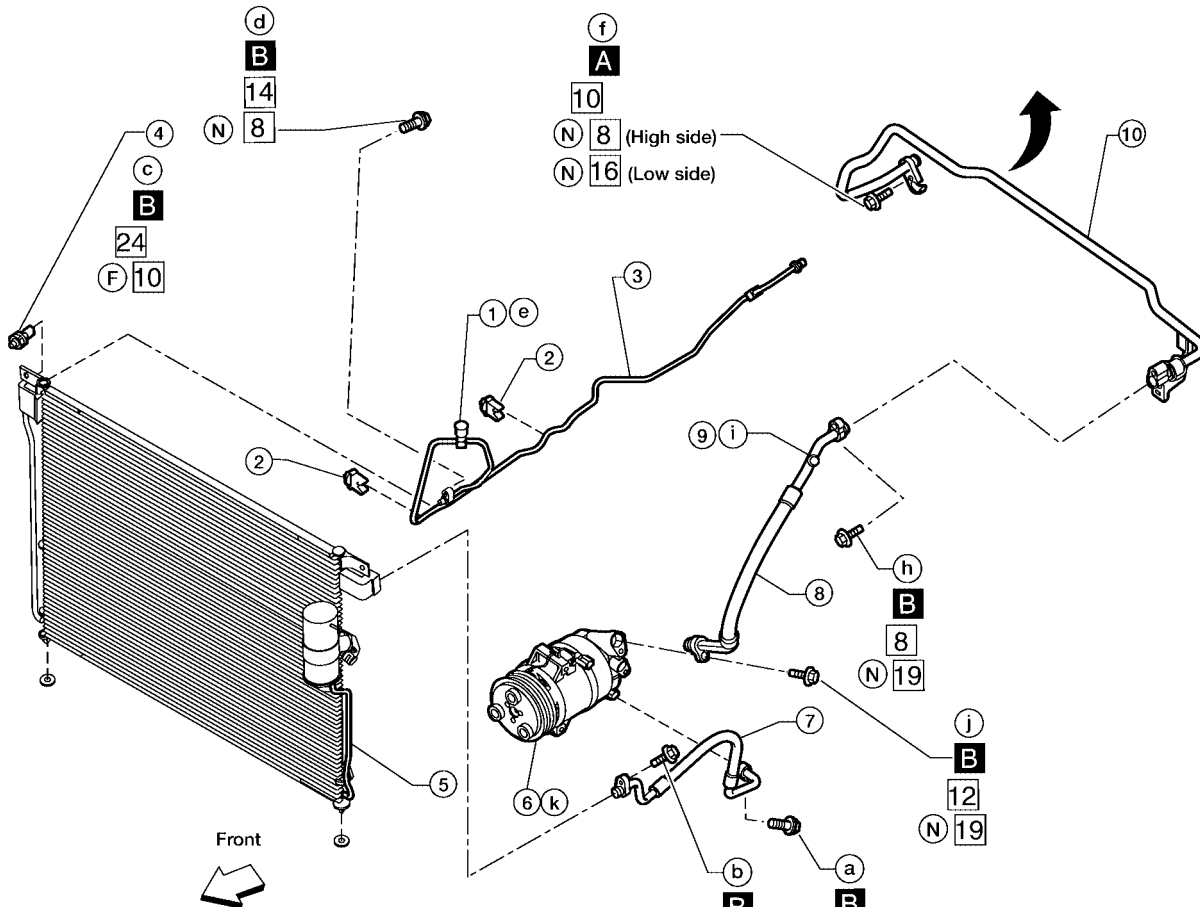
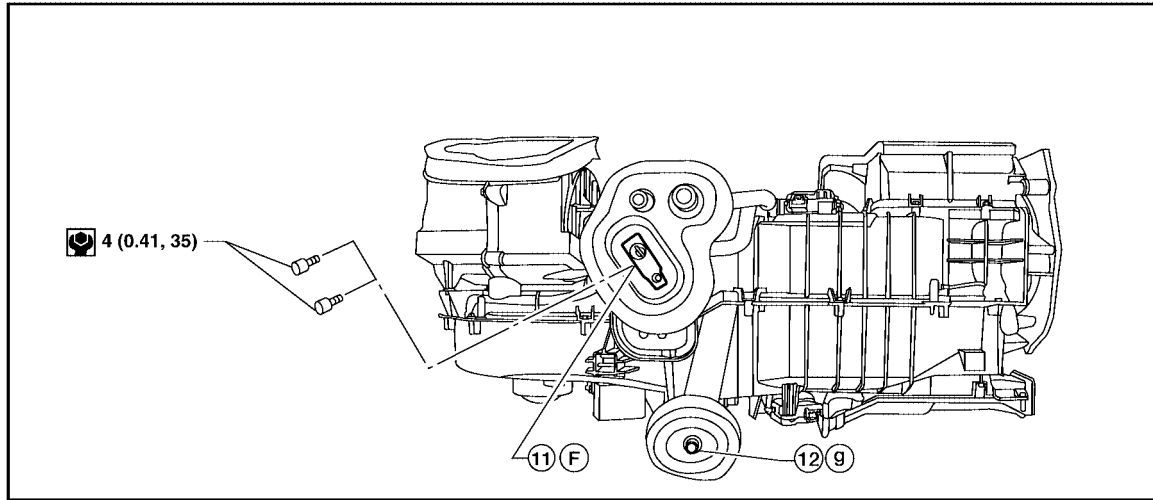

- : Refrigerant leak checking order (a-k)
- : Tightening torque
- : Wrench size
- : O-ring size
- ⊙ : N-m (kg-m, in-lb)
- A : 3.4 (0.35, 30)
- B : 9.3 (0.95, 82)
- (F) : Former type refrigerant connection
- (N) : New type refrigerant connection

WJIA1253E

A
B
C
D
E
F
G
H
I
MTC
K
L
M

PRECAUTIONS

- | | | |
|------------------------------------|-----------------------------------|-------------------------------|
| 1. High-pressure service valve | 2. Clip | 3. High-pressure A/C pipe |
| 4. Refrigerant pressure sensor | 5. Condenser | 6. Compressor shaft seal |
| 7. High-pressure flexible A/C hose | 8. Low-pressure flexible A/C hose | 9. Low-pressure service valve |
| 10. Low-pressure A/C pipe | 11. Expansion valve | 12. A/C drain hose |

CAUTION:

The new and former refrigerant connections use different O-ring configurations. Do not confuse O-rings since they are not interchangeable. If a wrong O-ring is installed, refrigerant will leak at or around the connection.

O-Ring Part Numbers and Specifications

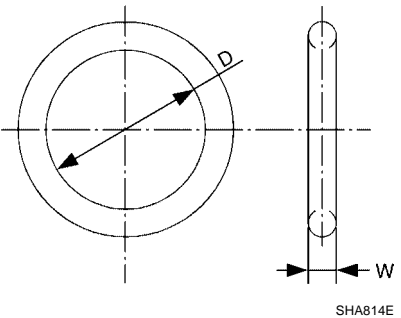
	Connec- tion type	O-ring size	Part number*	D mm (in)	W mm (in)
	New	8	92471 N8210	6.8 (0.268)	1.85 (0.0728)
	Former	10	J2476 89956	9.25 (0.3642)	1.78 (0.0701)
	New	12	92472 N8210	10.9 (0.429)	2.43 (0.0957)
	Former		92475 71L00	11.0 (0.433)	2.4 (0.094)
	New	16	92473 N8210	13.6 (0.535)	2.43 (0.0957)
	Former		92475 72L00	14.3 (0.563)	2.3 (0.091)
	New	19	92474 N8210	16.5 (0.650)	2.43 (0.0957)
	Former		92477 N8200	17.12 (0.6740)	1.78 (0.0701)
	New	24	92195 AH300	21.8 (0.858)	2.4 (0.094)

*: Always check with the Parts Department for the latest parts information.

WARNING:

Make sure all refrigerant is discharged into the recycling equipment and the pressure in the system is less than atmospheric pressure. Then gradually loosen the discharge side hose fitting and remove it.

CAUTION:

When replacing or cleaning refrigerant cycle components, observe the following.

- When the compressor is removed, store it in the same position as it is when mounted on the car. Failure to do so will cause oil to enter the low pressure chamber.
- When connecting tubes, always use a torque wrench and a back-up wrench.
- After disconnecting tubes, immediately plug all openings to prevent entry of dirt and moisture.
- When installing an air conditioner in the vehicle, connect the pipes as the final stage of the operation. Do not remove the seal caps of pipes and other components until just before required for connection.
- Allow components stored in cool areas to warm to working area temperature before removing seal caps. This prevents condensation from forming inside A/C components.
- Thoroughly remove moisture from the refrigeration system before charging the refrigerant.
- Always replace used O-rings.
- When connecting tube, apply oil to circle of the O-rings shown in illustration. Be careful not to apply oil to threaded portion.
Oil name: NISSAN A/C System Oil Type S or equivalent
- O-ring must be closely attached to dented portion of tube.
- When replacing the O-ring, be careful not to damage O-ring and tube.
- Connect tube until you hear it click, then tighten the nut or bolt by hand until snug. Make sure that the O-ring is installed to tube correctly.
- After connecting line, conduct leak test and make sure that there is no leakage from connections. When the refrigerant leaking point is found, disconnect that line and replace the O-ring. Then tighten connections of seal seat to the specified torque.

PRECAUTIONS

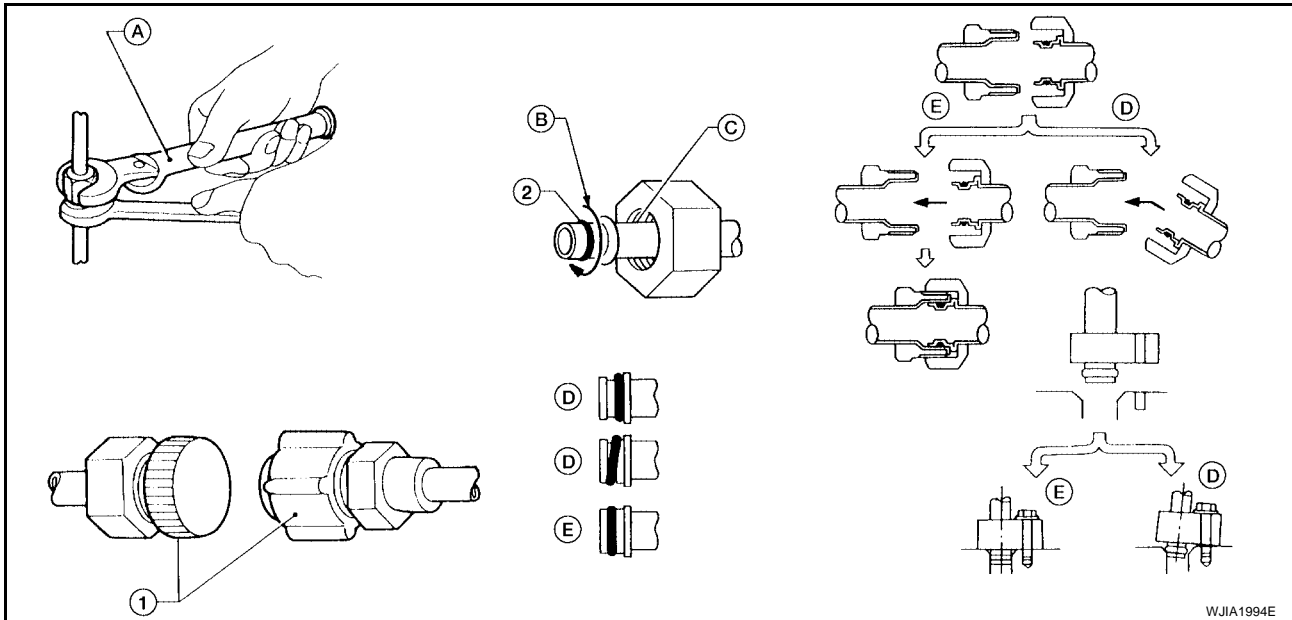

- | | | |
|--------------|-------------------------------|------------------|
| 1. Plug | 2. O-ring | A. Torque wrench |
| B. Apply oil | C. Do not apply oil to thread | D. No good |
| E. Good | | |

Precautions for Servicing Compressor

EJS004QY

- Plug all openings to prevent moisture and foreign matter from entering.
- When the compressor is removed, store it in the same position as it is when mounted on the car.
- When replacing or repairing compressor, follow "Maintenance of Oil Quantity in Compressor" exactly. Refer to [MTC-19, "Maintenance of Oil Quantity in Compressor"](#).
- Keep friction surfaces between clutch and pulley clean. If the surface is contaminated with oil, wipe it off by using a clean waste cloth moistened with thinner.
- After compressor service operation, turn the compressor shaft by hand more than 5 turns in both directions. This will equally distribute oil inside the compressor. After the compressor is installed, let the engine idle and operate the compressor for 1 hour.
- After replacing the compressor magnet clutch, apply voltage to the new one and check for normal operation. Refer to [MTC-102, "Removal and Installation for Compressor Clutch"](#).

Precautions for Service Equipment RECOVERY/RECYCLING EQUIPMENT

EJS004QZ

Follow the manufacturer's instructions for machine operation and machine maintenance. Never introduce any refrigerant other than that specified into the machine.

ELECTRONIC LEAK DETECTOR

Follow the manufacturer's instructions for tester operation and tester maintenance.

PRECAUTIONS

VACUUM PUMP

The oil contained inside the vacuum pump is not compatible with the specified oil for HFC-134a (R-134a) A/C systems. The vent side of the vacuum pump is exposed to atmospheric pressure so the vacuum pump oil may migrate out of the pump into the service hose. This is possible when the pump is switched off after evacuation (vacuuming) and hose is connected to it.

To prevent this migration, use a manual valve situated near the hose-to-pump connection, as follows.

- Usually vacuum pumps have a manual isolator valve as part of the pump. Close this valve to isolate the service hose from the pump.
- For pumps without an isolator, use a hose equipped with a manual shut-off valve near the pump end. Close the valve to isolate the hose from the pump.
- If the hose has an automatic shut off valve, disconnect the hose from the pump: as long as the hose is connected, the valve is open and lubricating oil may migrate.

Some one-way valves open when vacuum is applied and close under a no vacuum condition. Such valves may restrict the pump's ability to pull a deep vacuum and are not recommended.

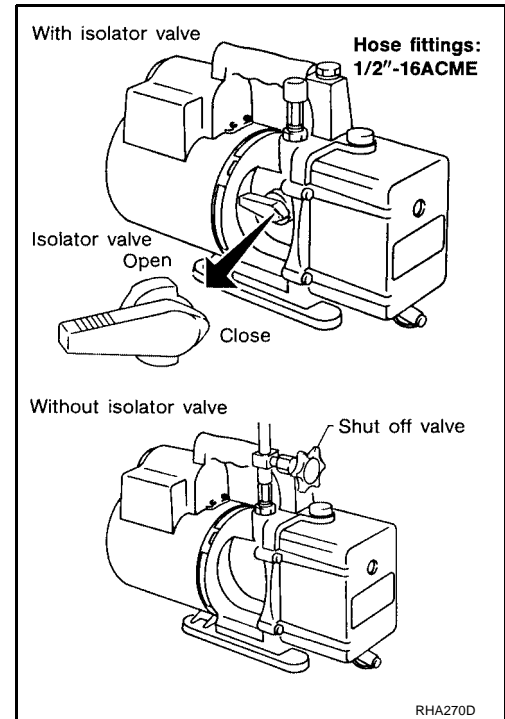

MANIFOLD GAUGE SET

Be certain that the gauge face indicates HFC-134a (R-134a). Make sure the gauge set has 1/2"-16 ACME threaded connections for service hoses. Confirm the set has been used only with refrigerant HFC-134a (R-134a) along with specified oil.

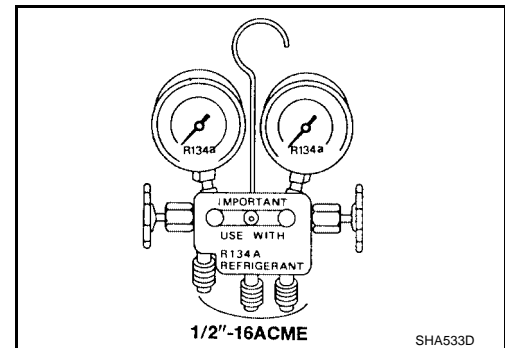

SERVICE HOSES

Be certain that the service hoses display the markings described (colored hose with black stripe). All hoses must include positive shut-off devices (either manual or automatic) near the end of the hoses opposite the manifold gauge.

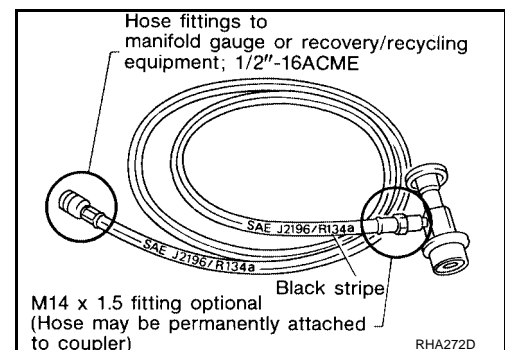

PRECAUTIONS

SERVICE COUPLERS

Never attempt to connect HFC-134a (R-134a) service couplers to a CFC-12 (R-12) A/C system. The HFC-134a (R-134a) couplers will not properly connect to the CFC-12 (R-12) system. If an improper connection is attempted, discharging and contamination may occur.

Shut-off valve rotation	A/C service valve
Clockwise	Open
Counterclockwise	Close

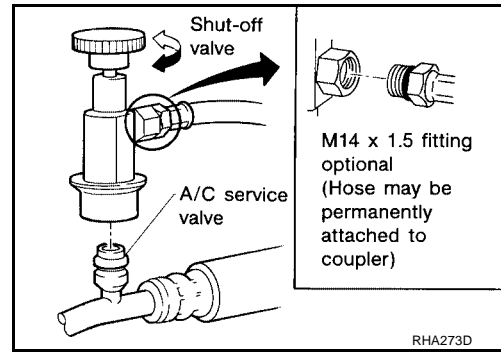

REFRIGERANT WEIGHT SCALE

Verify that no refrigerant other than HFC134a (R-134a) and specified oils have been used with the scale. If the scale controls refrigerant flow electronically, the hose fitting must be 1/2"-16 ACME.

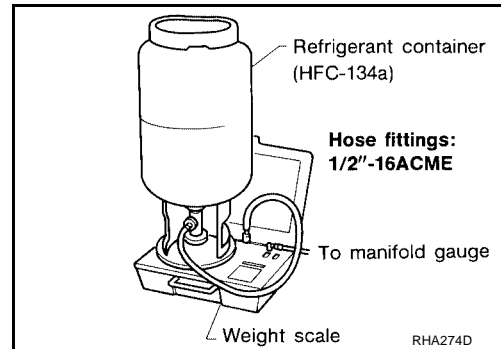

CHARGING CYLINDER

Using a charging cylinder is not recommended. Refrigerant may be vented into air from cylinder's top valve when filling the cylinder with refrigerant. Also, the accuracy of the cylinder is generally less than that of an electronic scale or of quality recycle/recharge equipment.

A
B
C
D
E
F
G
H
I
K
L
M

MTC

PREPARATION

PREPARATION

PFP:00002

Special Service Tools

EJS004R1

The actual shapes of Kent-Moore tools may differ from those of special service tools illustrated here.

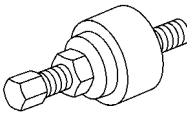
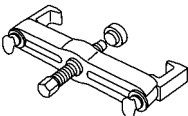
Tool number (Kent-Moore No.) Tool name	Description
— (J-38873-A) Pulley installer <div style="text-align: center;">  <p>LHA171</p> </div>	Installing pulley
KV99233130 (J-29884) Pulley puller <div style="text-align: center;">  <p>LHA172</p> </div>	Removing pulley



HFC-134a (R-134a) Service Tools and Equipment

EJS004R2



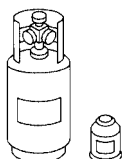

Never mix HFC-134a (R-134a) refrigerant and/or the specified oil with CFC-12 (R-12) refrigerant and/or the oil.

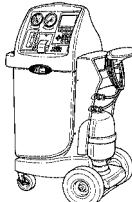
Separate and non-interchangeable service equipment must be used for handling each type of refrigerant/oil. Refrigerant container fittings, service hose fittings and service equipment fittings (equipment which handles refrigerant and/or oil) are different between CFC-12 (R-12) and HFC-134a (R-134a). This is to avoid mixed use of the refrigerants/oil.

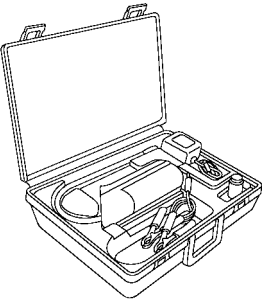
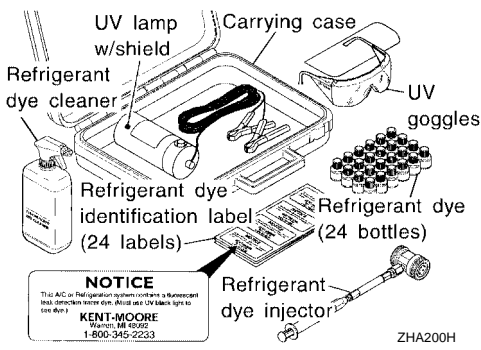
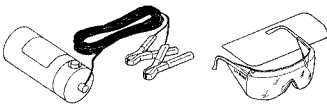

Adapters that convert one size fitting to another must never be used refrigerant/oil contamination will occur and compressor failure will result.

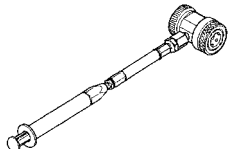
Tool number (Kent-Moore No.) Tool name	Description
HFC-134a (R-134a) (—) Refrigerant <div style="text-align: center;">  <p>S-NT196</p> </div>	Container color: Light blue Container marking: HFC-134a (R-134a) Fitting size: Thread size ● large container 1/2"-16 ACME
— (—) NISSAN A/C System Oil Type S <div style="text-align: center;">  <p>S-NT197</p> </div>	Type: Poly alkylene glycol oil (PAG), type S Application: HFC-134a (R-134a) swash plate compressors (NISSAN only) Lubricity: 40 m ℓ (1.4 US fl oz, 1.4 Imp fl oz)
KV991J0130 (ACR2005-NI) ACR A/C Service Center <div style="text-align: center;">  <p>WJIA0293E</p> </div>	Refrigerant Recovery and Recycling and Recharging

PREPARATION

Tool number (Kent-Moore No.) Tool name	Description	
<p>— (J-41995) Electronic refrigerant leak detector</p>	<p>Power supply: ● DC 12V (battery terminal)</p>  <p style="text-align: right;">AHA281A</p>	A B C D
<p>— (J-43926) Refrigerant dye leak detection kit Kit includes: (J-42220) UV lamp and UV safety goggles (J-41459) Refrigerant dye injector (J-41447) HFC-134a (R-134a) Fluorescent leak detection dye (box of 24, 1/4 ounce bottles) (J-43872) Refrigerant dye cleaner</p>	<p>Power supply: ● DC 12V (battery terminal)</p> 	E F G H
<p>— (J-42220) Fluorescent dye leak detector</p>	<p>Power supply: ● DC 12V (battery terminal)</p> <p>For checking refrigerant leak when fluorescent dye is installed in A/C system. Includes: UV lamp and UV safety goggles</p>  <p style="text-align: right;">SHA438F</p>	I MTC
<p>— (J-41447) HFC-134a (R-134a) Fluorescent leak detection dye (box of 24, 1/4 ounce bottles)</p>	<p>Application: For HFC-134a (R-134a) PAG oil Container: 1/4 ounce (7.4cc) bottle (Includes self-adhesive dye identification labels for affixing to vehicle after charging system with dye.)</p>  <p style="text-align: right;">Refrigerant dye (24 bottles)</p> <p style="text-align: right;">SHA439F</p>	K L M
<p>— (J-41459) HFC-134a (R-134a) Refrigerant dye injector Use with J-41447, 1/4 ounce bottle</p>	<p>For injecting 1/4 ounce of fluorescent leak detection dye into A/C system.</p>  <p style="text-align: right;">SHA440F</p>	
<p>— (J-43872) Refrigerant dye cleaner</p>	<p>For cleaning dye spills.</p>  <p style="text-align: right;">SHA441F</p>	

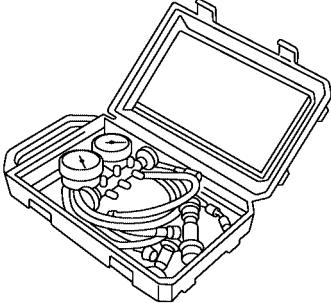
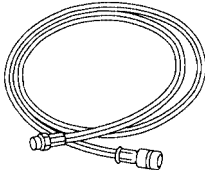
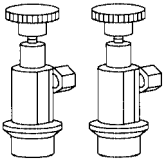
PREPARATION

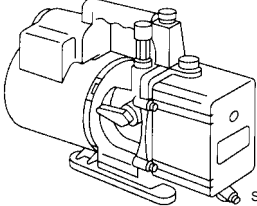
Tool number (Kent-Moore No.) Tool name	Description
<p>— (J-39183-C) Manifold gauge set (with hoses and couplers)</p>  <p style="text-align: right; font-size: small;">RJIA0196E</p>	<p>Identification:</p> <ul style="list-style-type: none"> ● The gauge face indicates R-134a. Fitting size-Thread size ● 1/2"-16 ACME
<p>Service hoses:</p> <ul style="list-style-type: none"> ● High side hose (J-39500-72B) ● Low side hose (J-39500-72R) ● Utility hose (J-39500-72Y)  <p style="text-align: right; font-size: small;">S-NT201</p>	<p>Hose color:</p> <ul style="list-style-type: none"> ● Low side hose: Blue with black stripe ● High side hose: Red with black stripe ● Utility hose: Yellow with black stripe or green with black stripe <p>Hose fitting to gauge:</p> <ul style="list-style-type: none"> ● 1/2"-16 ACME
<p>Service couplers</p> <ul style="list-style-type: none"> ● High side coupler (J-39500-20A) ● Low side coupler (J-39500-24A)  <p style="text-align: right; font-size: small;">S-NT202</p>	<p>Hose fitting to service hose:</p> <ul style="list-style-type: none"> ● M14 x 1.5 fitting is optional or permanently attached.
<p>— (J-39699) Refrigerant weight scale</p>  <p style="text-align: right; font-size: small;">S-NT200</p>	<p>For measuring of refrigerant Fitting size-Thread size</p> <ul style="list-style-type: none"> ● 1/2"-16 ACME
<p>— (J-39649) Vacuum pump (Including the isolator valve)</p>  <p style="text-align: right; font-size: small;">S-NT203</p>	<p>Capacity:</p> <ul style="list-style-type: none"> ● Air displacement: 4 CFM ● Micron rating: 20 microns ● Oil capacity: 482 g (17 oz) <p>Fitting size-Thread size</p> <ul style="list-style-type: none"> ● 1/2"-16 ACME

PREPARATION

Commercial Service Tools

EJS004R3

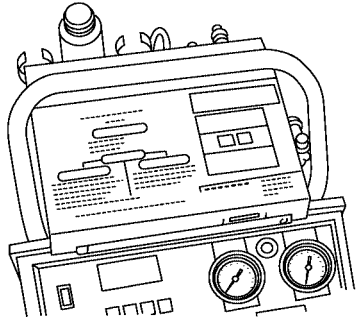
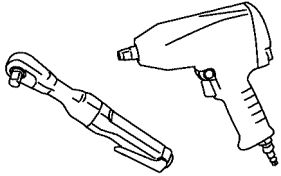
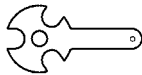
Tool name	Description
<p>(J-41810-NI) Refrigerant identifier equipment (R-134a)</p>  <p style="text-align: right;">RJIA0197E</p>	<p>For checking refrigerant purity and system contamination</p>
<p>Power tool</p>  <p style="text-align: right;">PBIC0190E</p>	<p>Loosening bolts and nuts</p>
<p>(J-44614) Clutch disc holding tool</p>  <p style="text-align: right;">WHA230</p>	<p>Clutch disc holding tool</p>

A
B
C
D
E
F
G
H
I

MTC

K
L
M

REFRIGERATION SYSTEM

REFRIGERATION SYSTEM

PFP:KA990

Components REFRIGERATION SYSTEM

EJS004R4

SEC. 270 • 271

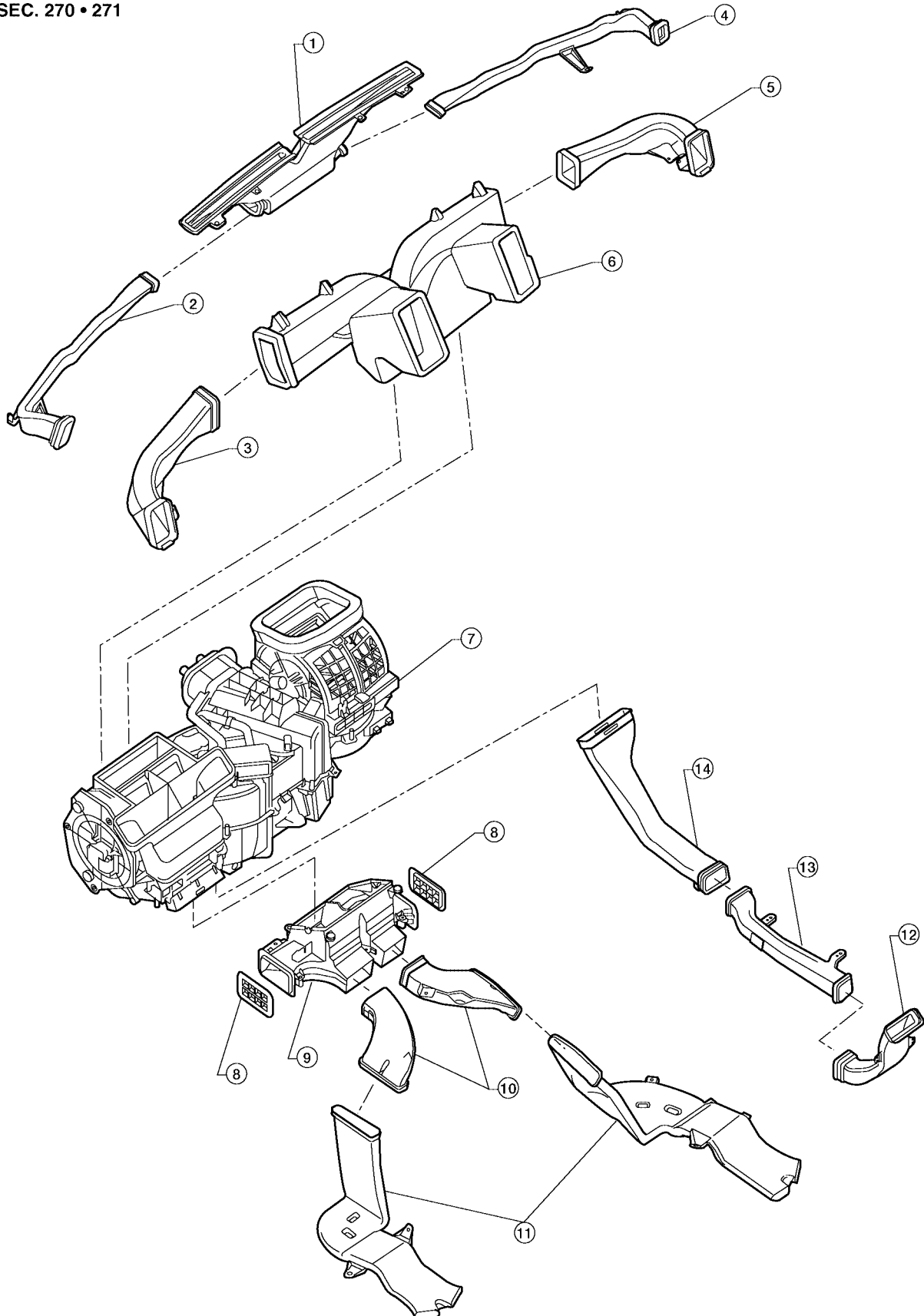

LJIA0155E

REFRIGERATION SYSTEM

- | | | |
|---|---------------------------------|---------------------------|
| 1. Defroster nozzle | 2. LH side demister duct | 3. LH ventilator duct |
| 4. RH side demister duct | 5. RH ventilator duct | 6. Center ventilator duct |
| 7. Front heater and cooling unit assembly | 8. Floor connector duct grilles | 9. Floor connector duct |
| 10. Front ducts | 11. Floor ducts | 12. Rear console duct |
| 13. Center console duct | 14. Front console duct | |

Refrigerant Cycle

EJS004R5

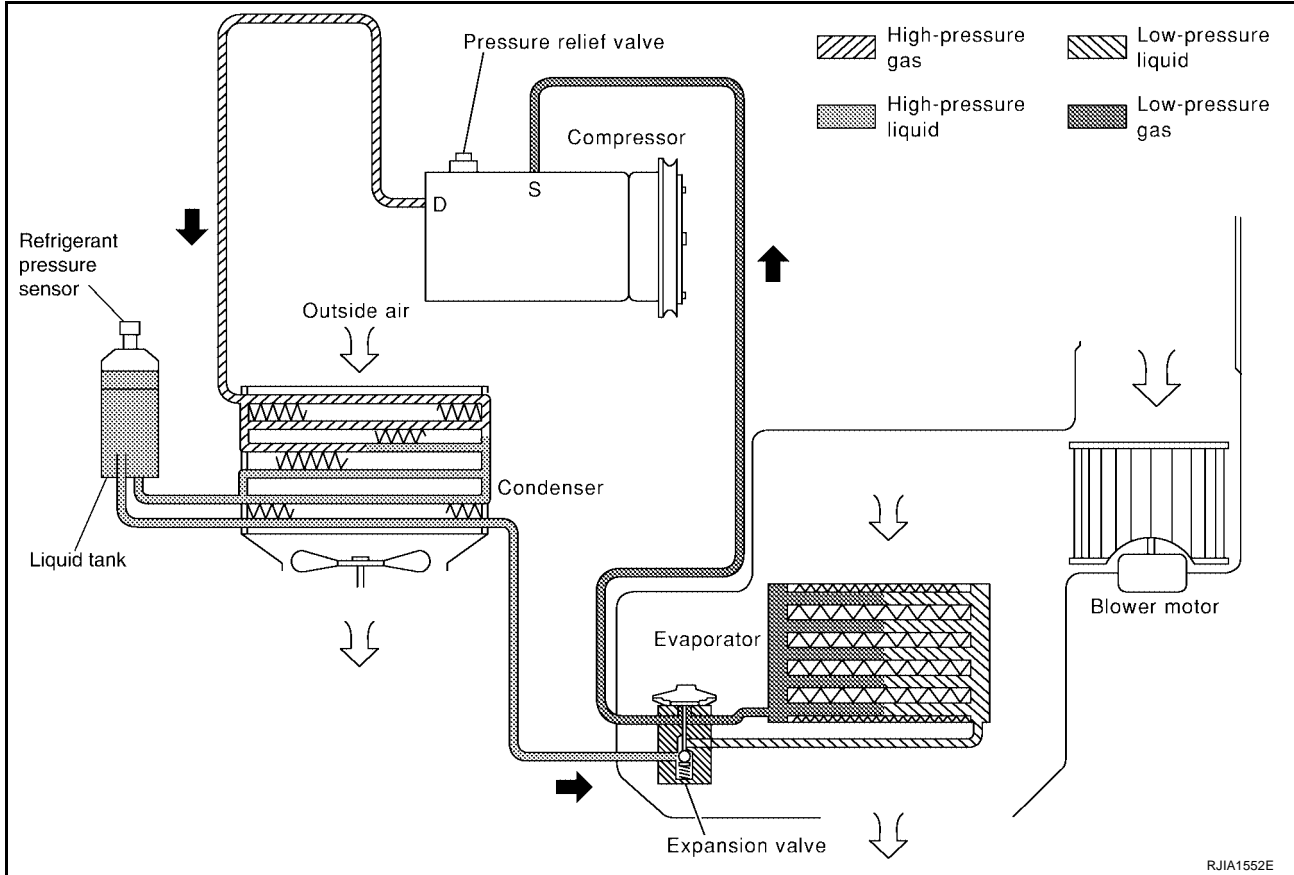

REFRIGERANT FLOW

The refrigerant flows in the standard pattern. Refrigerant flows through the compressor, condenser, liquid tank, expansion valve, evaporator, and back to the compressor. The refrigerant evaporation through the evaporator coil is controlled by an externally equalized expansion valve, located inside the evaporator case.

FREEZE PROTECTION

The compressor cycles on and off to maintain the evaporator temperature within a specified range. When the evaporator coil temperature falls below a specified point, the intake sensor interrupts the compressor operation. When the evaporator coil temperature rises above the specification, the intake sensor allows compressor operation.

Refrigerant System Protection REFRIGERANT PRESSURE SENSOR

EJS004R6

The refrigerant system is protected against excessively high- or low-pressures by the refrigerant pressure sensor, located on the condenser. If the system pressure rises above or falls below the specifications, the refrigerant pressure sensor detects the pressure inside the refrigerant line and sends a voltage signal to the ECM. The ECM de-energizes the A/C relay to disengage the magnetic compressor clutch when pressure on the high pressure side detected by refrigerant pressure sensor is over about 2,746 kPa (28 kg/cm², 398 psi), or below about 120 kPa (1.22 kg/cm², 17.4 psi).

REFRIGERATION SYSTEM

PRESSURE RELIEF VALVE

The refrigerant system is also protected by a pressure relief valve, located in the rear head of the compressor. When the pressure of refrigerant in the system increases to an abnormal level [more than 2,990 kPa (30.5 kg/cm² , 433.6 psi)], the release port on the pressure relief valve automatically opens and releases refrigerant into the atmosphere.

OIL

PFP:KLG00

OIL

Maintenance of Oil Quantity in Compressor

EJS004R7

The oil in the compressor circulates through the system with the refrigerant. Add oil to compressor when replacing any component or after a large refrigerant leakage has occurred. It is important to maintain the specified amount.

If oil quantity is not maintained properly, the following malfunctions may result:

- Lack of oil: May lead to a seized compressor
- Excessive oil: Inadequate cooling (thermal exchange interference)

OIL

Oil name: NISSAN A/C System Oil Type S or equivalent

CHECKING AND ADJUSTING

CAUTION:

If excessive oil leakage is noted, do not perform the oil return operation.

Start the engine and set the following conditions:

Test Conditions

- Engine speed: idling to 1,200 rpm
- A/C switch: ON
- Blower fan speed: HIGH
- Temperature control: optional [set so intake air temperature is 25° to 30° C (77° to 86°F)]
- Intake position: RECIRCULATION mode
- Perform oil return operation for about ten minutes

Adjust the oil quantity according to the following table.

Oil Adjusting Procedure for Components Replacement Except Compressor

After replacing any of the following major components, add the correct amount of oil to the system.

Amount of Oil to be Added

Part replaced	Oil to be added to system	Remarks
	Amount of oil m ℓ (US fl oz, Imp fl oz)	
Evaporator	75 (2.5, 2.6)	—
Condenser	75 (2.5, 2.6)	—
Liquid tank	5 (0.2, 0.2)	Add if compressor is not replaced.
In case of refrigerant leak	30 (1.0, 1.1)	Large leak
	—	Small leak *1

*1: If refrigerant leak is small, no addition of oil is needed.

OIL

Oil Adjustment Procedure for Compressor Replacement

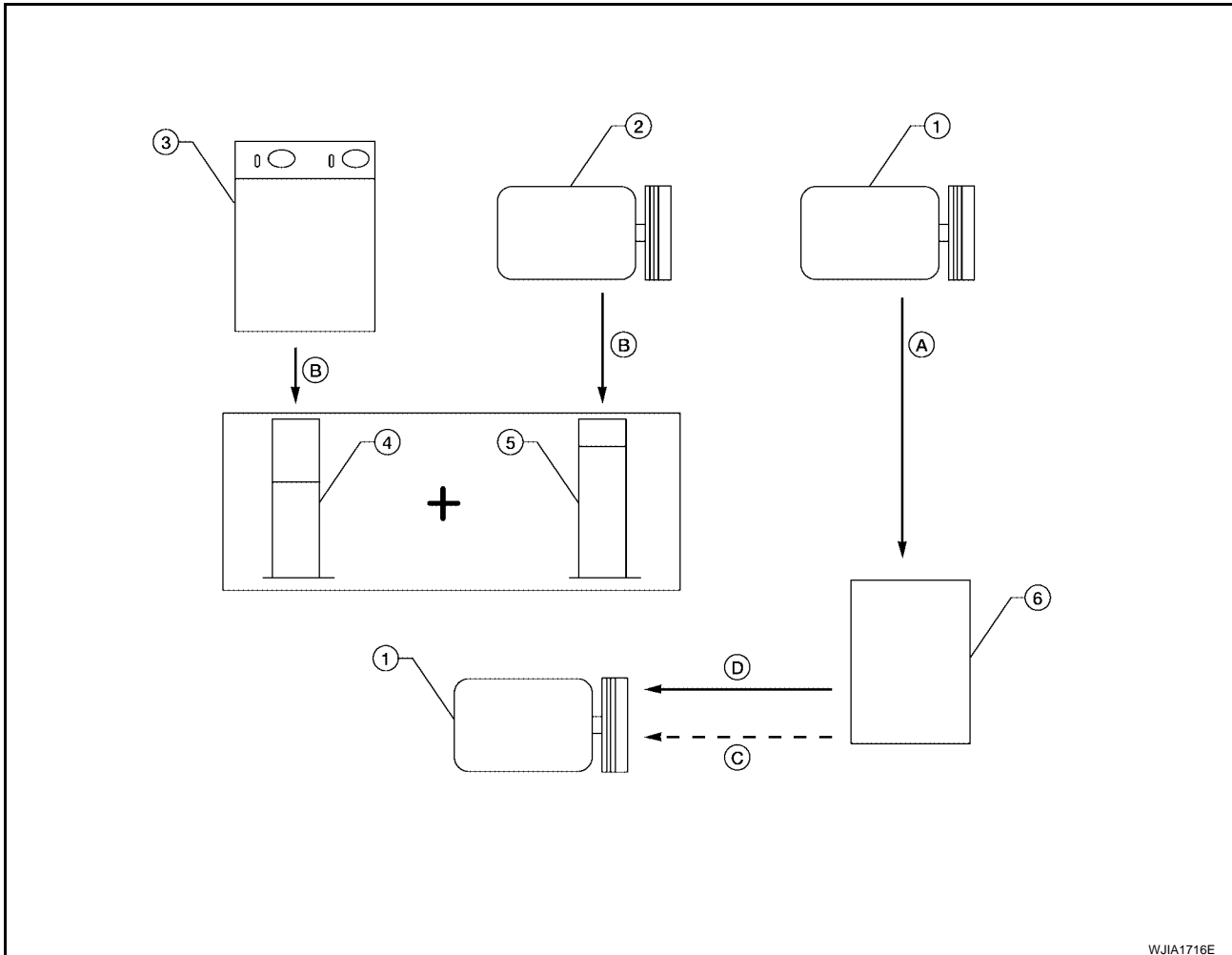

WJIA1716E

- | | | |
|---|-----------------------------------|---|
| 1. New compressor | 2. Old compressor | 3. Recovery/recycling equipment |
| 4. Measuring cup X | 5. Measuring cup Y | 6. New oil |
| A. Drain oil from the new compressor into clean container | B. Record amount of oil recovered | C. Add an additional 5 mℓ (0.2 US fl oz, 0.2 Imp fl oz) of new oil when replacing liquid tank |
| D. Install new oil equal to recorded amounts in measuring cups X plus Y | | |

- Before connecting recovery/recycling equipment to vehicle, check recovery/recycling equipment gauges. No refrigerant pressure should be displayed. If NG, recover refrigerant from equipment lines.
- Connect recovery/recycling equipment to vehicle. Confirm refrigerant purity in supply tank using recovery/recycling equipment and refrigerant identifier. If NG, refer to [MTC-4, "Contaminated Refrigerant"](#).
- Confirm refrigerant purity in vehicle A/C system using recovery/recycling equipment and refrigerant identifier. If NG, refer to [MTC-4, "Contaminated Refrigerant"](#).
- Discharge refrigerant into the refrigerant recovery/recycling equipment. Measure oil discharged into the recovery/recycling equipment.
- Drain the oil from the "old" (removed) compressor into a graduated container and recover the amount of oil drained.
- Drain the oil from the "new" compressor into a separate, clean container.
- Measure an amount of new oil installed equal to amount drained from "old" compressor. Add this oil to "new" compressor through the suction port opening.
- Measure an amount of new oil equal to the amount recovered during discharging. Add this oil to "new" compressor through the suction port opening.
- If the liquid tank also needs to be replaced, add an additional 5 mℓ (0.2 US fl oz, 0.2 Imp fl oz) of oil at this time.

OIL

Do not add this 5 mℓ (0.2 US fl oz, 0.2 Imp fl oz) of oil if only replacing the compressor.

A

B

C

D

E

F

G

H

I

MTC

K

L

M

AIR CONDITIONER CONTROL

AIR CONDITIONER CONTROL

PFP:27500

Description

EJS004R8

The front air control provides regulation of the vehicle's interior temperature. The system is based on the position of the front air controls temperature switch selected by the driver. This is done by utilizing a microcomputer, also referred to as the front air control, which receives input signals from the following two sensors:

- Intake sensor
- PBR (position balanced resistor)

The front air control uses these signals (including the set position of the temperature switch) to control:

- Outlet air volume
- Air temperature
- Air distribution

Operation

EJS004R9

AIR MIX DOOR CONTROL

The air mix door is controlled so that in-vehicle temperature changed based on the position of the temperature control dial.

BLOWER SPEED CONTROL

Blower speed is controlled based on front blower switch settings.

When blower switch is turned, the blower motor starts and increases air flow volume each time the blower switch is turned counterclockwise, and decreases air flow volume each time the blower switch is turned clockwise.

When engine coolant temperature is low, the blower motor operation is delayed to prevent cool air from flowing.

INTAKE DOORS CONTROL

The intake doors are controlled by the recirculation switch setting, and the mode (defroster) switch setting.

MODE DOOR CONTROL

The mode door is controlled by the position of the mode dial.

DEFROSTER DOOR CONTROL

The defroster door is controlled by the defroster dial set to defroster.

MAGNET CLUTCH CONTROL

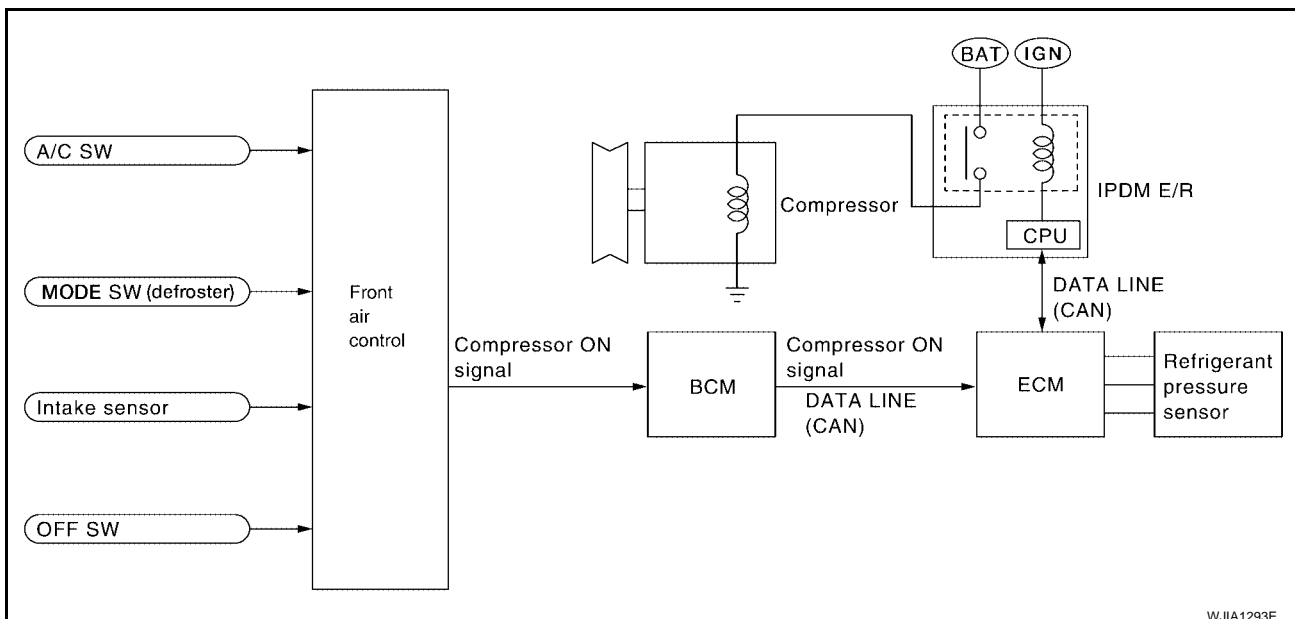

When the A/C switch is pressed, or the mode dial is turned to the defroster position, the front air control outputs a compressor ON signal to BCM.

The BCM then sends a compressor ON signal to ECM, via CAN communication line.

AIR CONDITIONER CONTROL

ECM judges whether compressor can be turned ON, based on each sensor status (refrigerant pressure sensor signal, throttle angle sensor, etc.). If it judges compressor can be turned ON, it sends compressor ON signal to IPDM E/R, via CAN communication line.

Upon receipt of compressor ON signal from ECM, IPDM E/R turns air conditioner relay ON to operate compressor.

A

B

C

D

E

F

G

H

I

MTC

K

L

M

AIR CONDITIONER CONTROL

EJS004RA

Description of Control System

The control system consists of input sensors, switches, the front air control (microcomputer) and outputs. The relationship of these components is shown in the figure below:

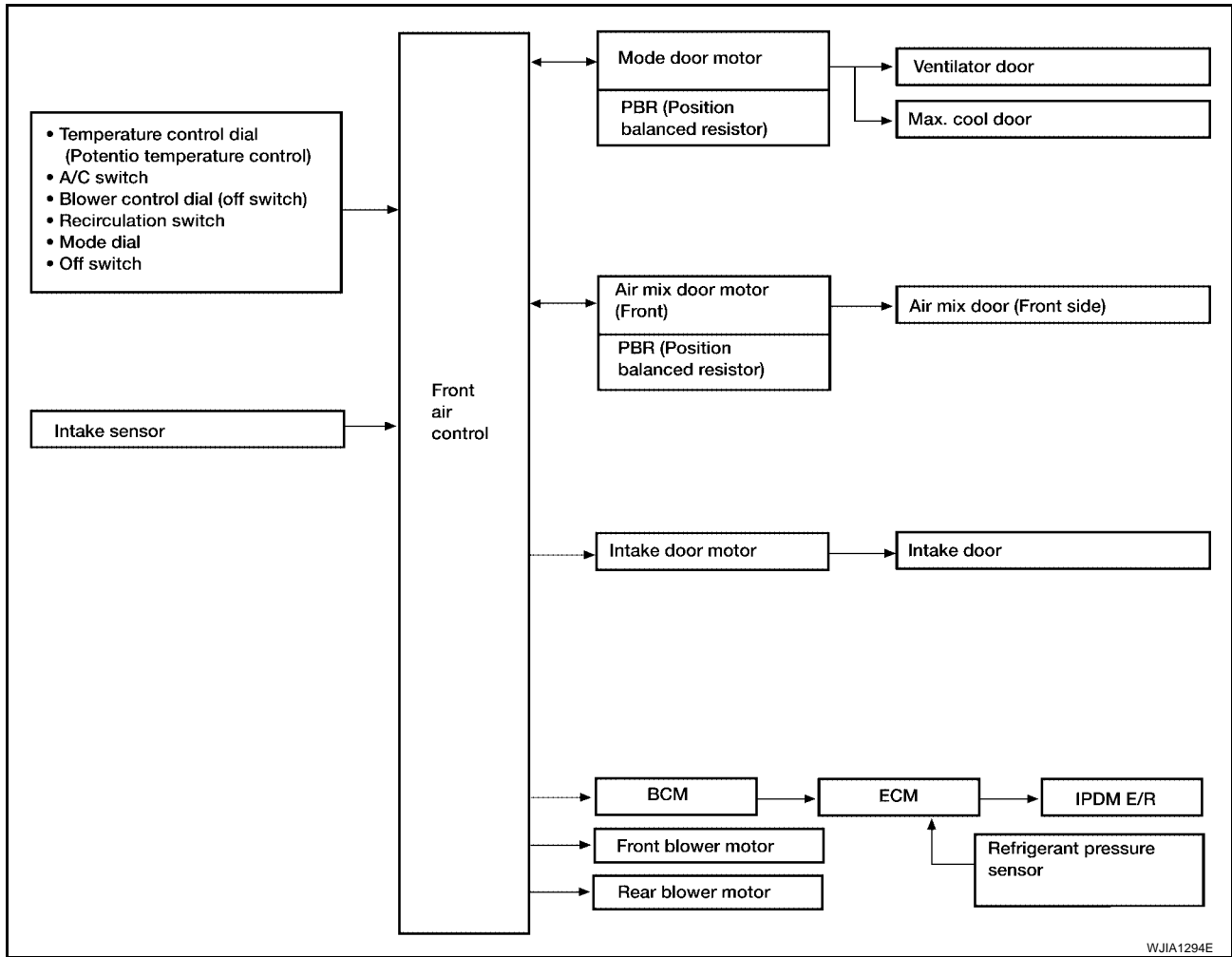

AIR CONDITIONER CONTROL

Control Operation

EJS004RB

Front air control

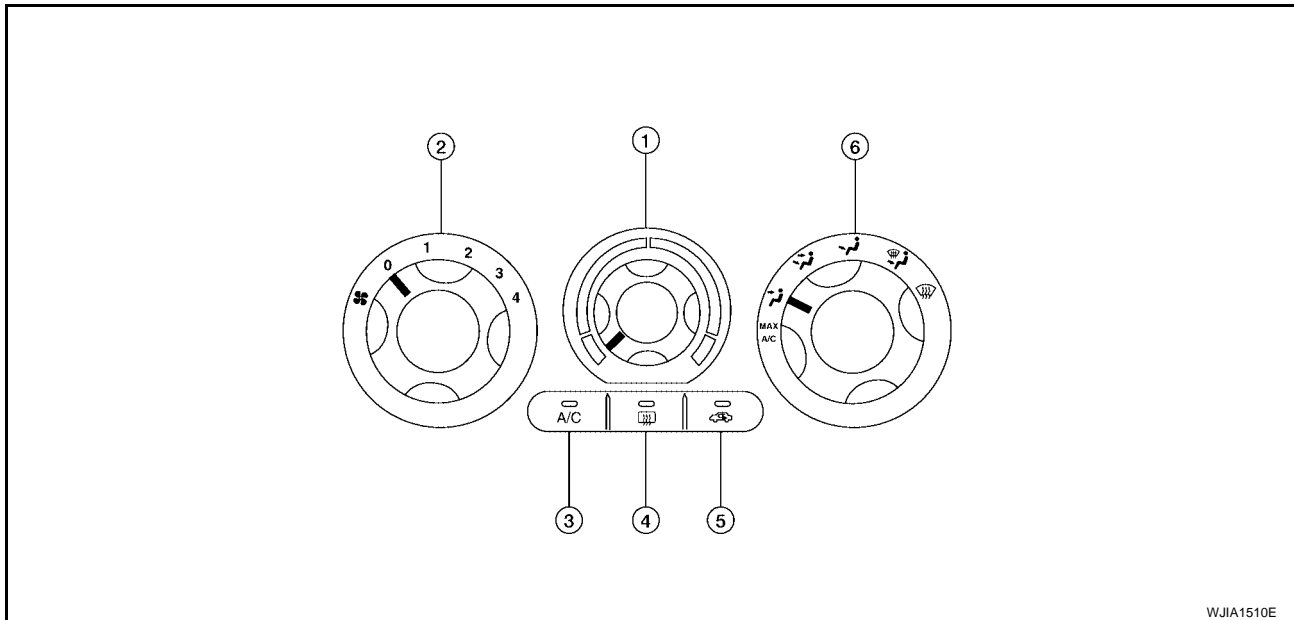

- | | | |
|--------------------------------|-------------------------|---------------|
| 1. Temperature control dial | 2. Blower control dial | 3. A/C switch |
| 4. Rear window defogger switch | 5. Recirculation switch | 6. Mode dial |

WJIA1510E

TEMPERATURE CONTROL DIAL (TEMPERATURE CONTROL)

Increases or decreases the set temperature.

RECIRCULATION () SWITCH

- When REC switch is ON, REC switch indicator turns ON, and air inlet is set to REC.
- When REC switch is turned OFF, or when compressor is turned from ON to OFF, REC switch is automatically turned OFF. REC mode can be re-entered by pressing REC switch again.
- REC switch is not operated when DEF switch is turned ON, or at the D/F position.

DEFROSTER () SWITCH

Positions the air outlet doors to the defrost position. Also positions the intake doors to the outside air position.

REAR WINDOW DEFOGGER SWITCH

When switch is ON, rear window is defogged.

OFF SWITCH (BLOWER SPEED SET TO 0)

The compressor and blower are OFF.

A/C SWITCH

The compressor is ON or OFF.

(Pressing the A/C switch when the AUTO switch is ON will turn off the A/C switch and compressor.)

MODE DIAL

Controls the air discharge outlets.

FRONT BLOWER CONTROL DIAL

Manually controls the four blower speeds.

A
B
C
D
E
F
G

H
I

MTC

K
L
M

AIR CONDITIONER CONTROL

Discharge Air Flow FRONT

EJS004RC

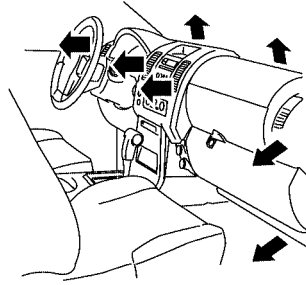

WJIA1296E

Mode door position	Air outlet/distribution		
	Vent	Foot	Defroster
	95%	5%	—
	60%	40%	—
	20%	55%	25%
	15%	50%	35%
	7%	15%	78%

Airflow always present at driver and passenger side demisters

AIR CONDITIONER CONTROL

EJS004RD

System Description SWITCHES AND THEIR CONTROL FUNCTION

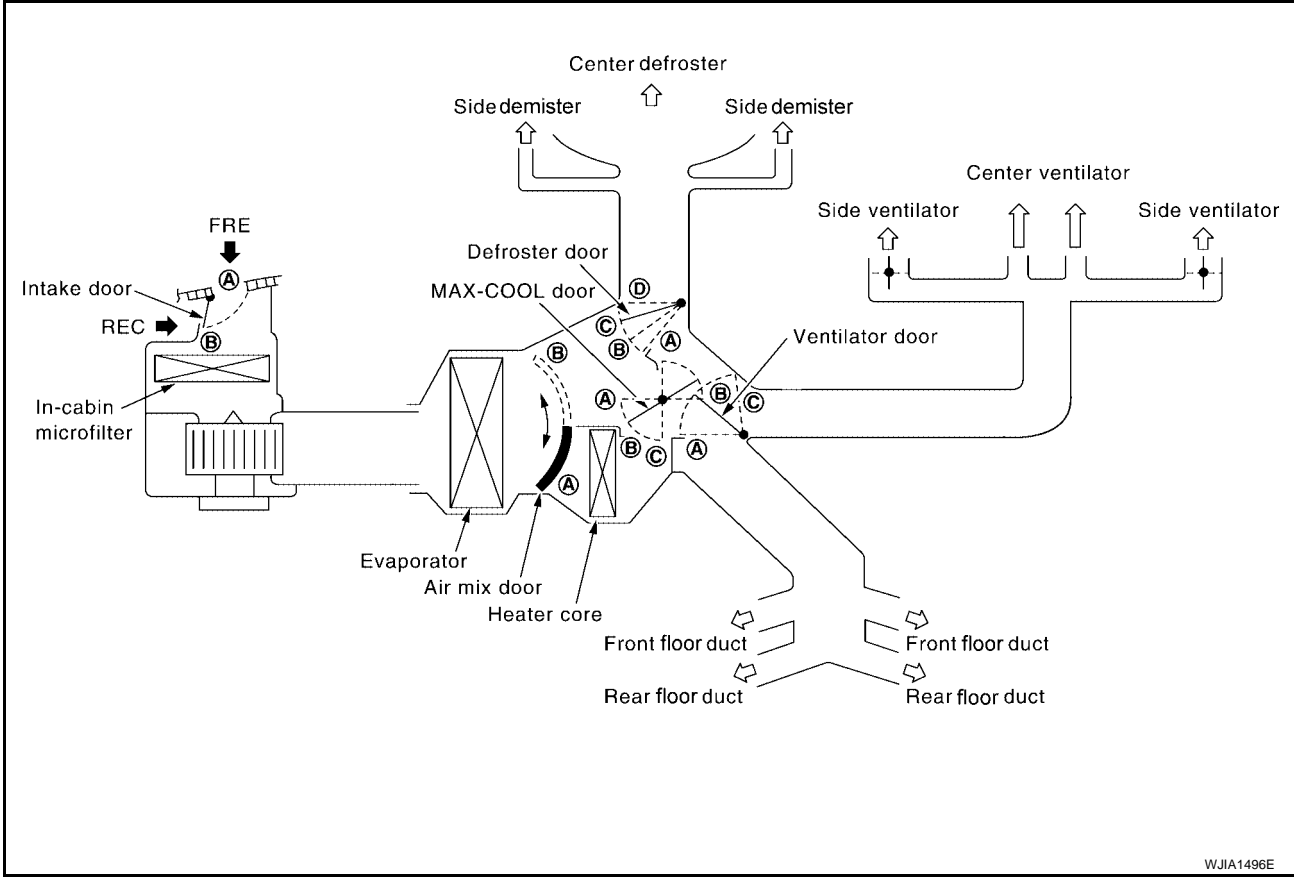

WJIA1496E

Position or switch	MODE SW				DEF SW		REC SW		Temperature dial			OFF SW
	VENT	B/L	FOOT	D/F	ON	OFF	ON	OFF	COLD	~	HOT	
Door												
Ventilator door	(A)	(B)	(C)	(C)	(C)	—	—	—	—	—	—	(C)
MAX-COOL door	(A)	(B)	(B)	(B)	(C)	—	—	—	—	—	—	(B)
Defroster door	(D)	(D)	(D _{or} C)	(B)	(A)	—	—	—	—	—	—	(C)
Intake door	—				(B)	—	(A)	(B)	—	—	—	(B)
Air mix door	—				—	—	—	—	(A)	—	(B)	—

WJIA1497E

AIR CONDITIONER CONTROL

CAN Communication System Description

EJS004RE

Refer to [LAN-25, "CAN COMMUNICATION"](#) .

TROUBLE DIAGNOSIS

PFP:00004

TROUBLE DIAGNOSIS

CONSULT-II Function (BCM)

EJS004RF

CONSULT-II can display each diagnostic item using the diagnostic test modes shown following.

BCM diagnostic test item	Diagnostic mode	Description
Inspection by part	WORK SUPPORT	Supports inspections and adjustments. Commands are transmitted to the BCM for setting the status suitable for required operation, input/output signals are received from the BCM and received data is displayed.
	DATA MONITOR	Displays BCM input/output data in real time.
	ACTIVE TEST	Operation of electrical loads can be checked by sending drive signal to them.
	SELF-DIAG RESULTS	Displays BCM self-diagnosis results.
	CAN DIAG SUPPORT MNTR	The result of transmit/receive diagnosis of CAN communication can be read.
	ECU PART NUMBER	BCM part number can be read.
	CONFIGURATION	Performs BCM configuration read/write functions.

CONSULT-II BASIC OPERATION

CAUTION:

If CONSULT-II is used with no connection of CONSULT-II CONVERTER, malfunctions might be detected in self-diagnosis depending on control unit which carries out CAN communication.

1. With the ignition switch OFF, connect CONSULT-II and CONSULT-II CONVERTER to the data link connector, and turn the ignition switch ON.

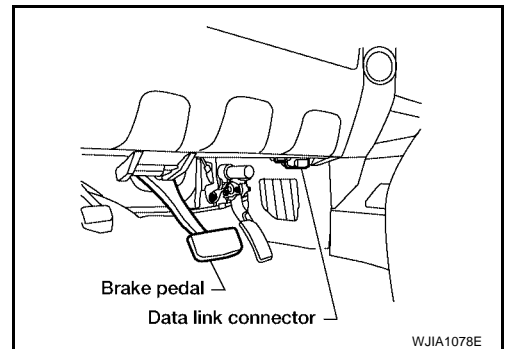

2. Touch "START (NISSAN BASED VHCL)".

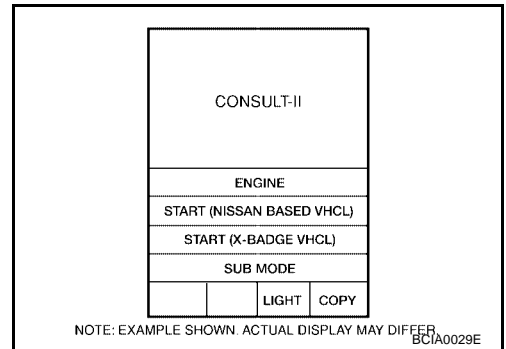

3. Touch "BCM" on "SELECT SYSTEM" screen.
If "BCM" is not indicated, go to [GI-40, "CONSULT-II Data Link Connector \(DLC\) Circuit"](#).

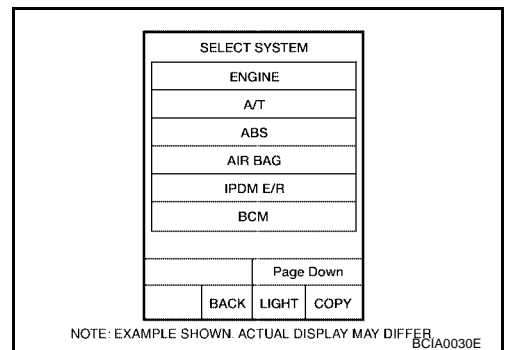

TROUBLE DIAGNOSIS

DATA MONITOR

Operation Procedure

1. Touch "AIR CONDITIONER" on "SELECT TEST ITEM" screen.

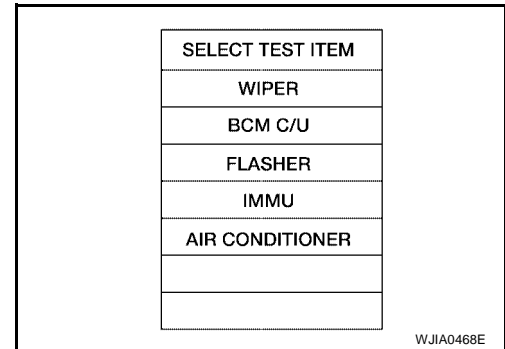

2. Touch "DATA MONITOR" on "SELECT DIAG MODE" screen.

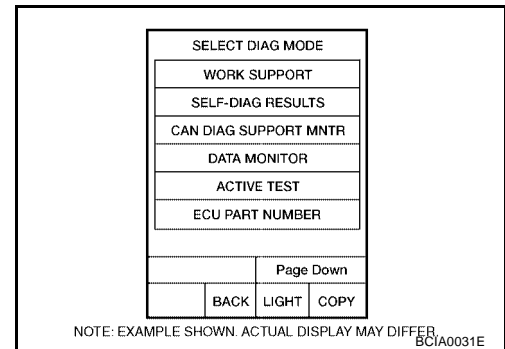

3. Touch either "ALL SIGNALS" or "SELECTION FROM MENU" on "DATA MONITOR" screen.

ALL SIGNALS	Monitors all the items.
SELECTION FROM MENU	Selects and monitors the individual item selected.

4. When "SELECTION FROM MENU" is selected, touch items to be monitored. When "ALL SIGNALS" is selected, all the items will be monitored.

5. Touch "START".

6. Touch "RECORD" while monitoring, then the status of the monitored item can be recorded. To stop recording, touch "STOP".

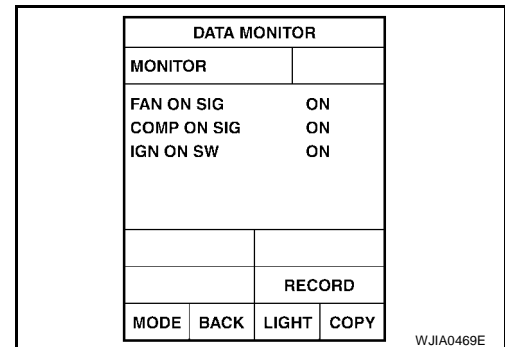

Display Item List

Monitor item name "OPERATION OR UNIT"	Contents
IGN ON SW "ON/OFF"	Displays "IGN Position (ON)/OFF, ACC Position (OFF)" status as judged from ignition switch signal.
COMP ON SIG "ON/OFF"	Displays "COMP (ON)/COMP (OFF)" status as judged from air conditioner switch signal.
FAN ON SIG "ON/OFF"	Displays "FAN (ON)/FAN (OFF)" status as judged from blower motor switch signal.

TROUBLE DIAGNOSIS

How to Perform Trouble Diagnosis for Quick and Accurate Repair WORK FLOW

EJS004RG

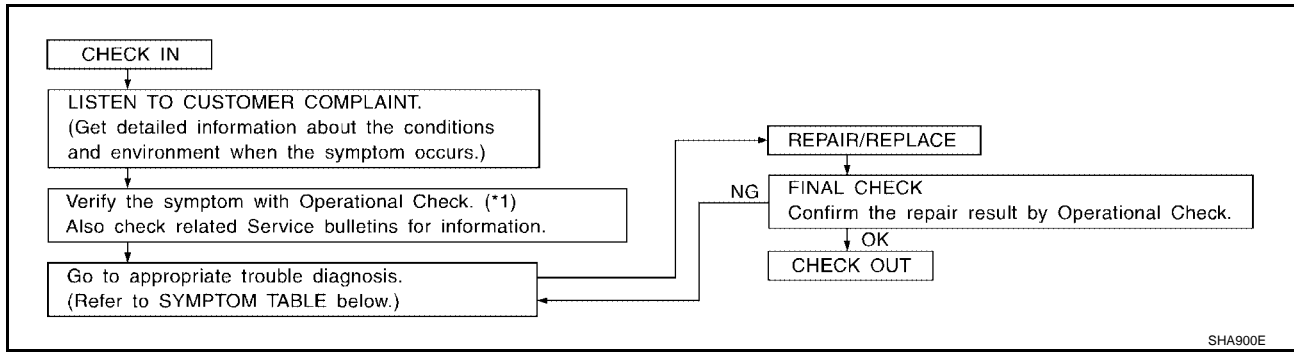

*1 [ATC-53. "Operational Check \(Front\)".](#)

SYMPTOM TABLE

Symptom	Reference Page	
A/C system does not come on.	Go to Trouble Diagnosis Procedure for A/C System.	MTC-42
Air outlet does not change.	Go to Trouble Diagnosis Procedure for Mode Door Motor.	MTC-45
Mode door motor is malfunctioning.		
Discharge air temperature does not change.	Go to Trouble Diagnosis Procedure for Air Mix Door Motor.	MTC-49
Air mix door motor is malfunctioning.		
Intake door does not change.	Go to Trouble Diagnosis Procedure for Intake Door Motor.	MTC-53
Intake door motor is malfunctioning.		
Front blower motor operation is malfunctioning.	Go to Trouble Diagnosis Procedure for Front Blower Motor.	MTC-57
Magnet clutch does not engage.	Go to Trouble Diagnosis Procedure for Magnet Clutch.	MTC-65
Insufficient cooling	Go to Trouble Diagnosis Procedure for Insufficient Cooling.	MTC-70
Insufficient heating	Go to Trouble Diagnosis Procedure for Insufficient Heating.	MTC-77
Noise	Go to Trouble Diagnosis Procedure for Noise.	MTC-78

TROUBLE DIAGNOSIS

Component Parts and Harness Connector Location ENGINE COMPARTMENT

EJS004RH

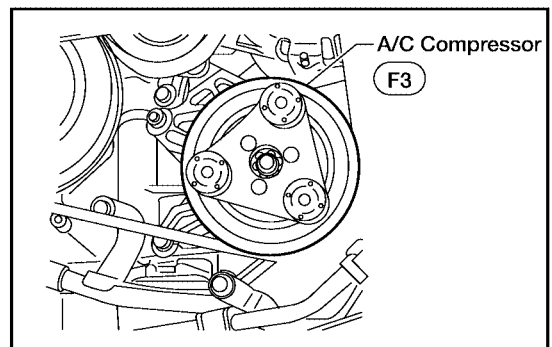
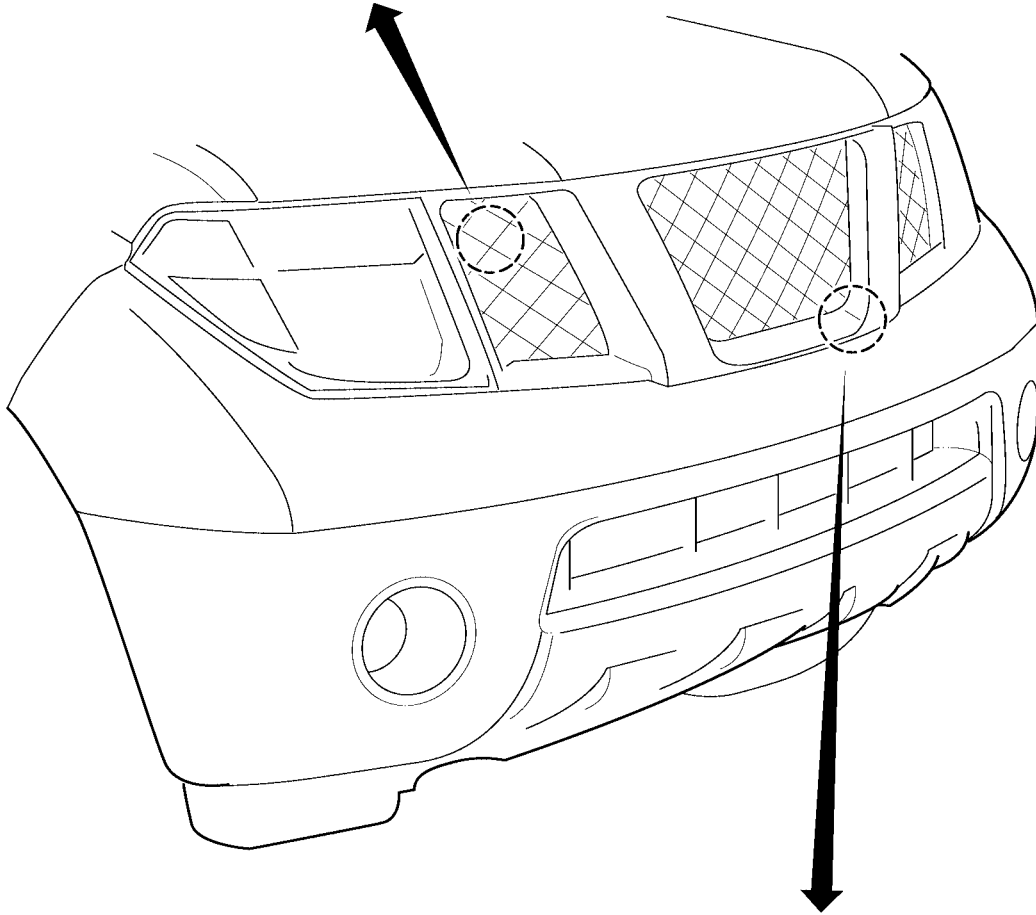
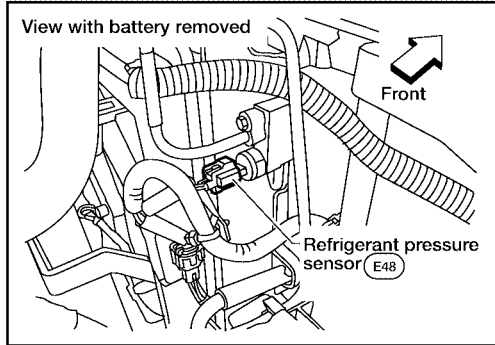

WJIA1489E

TROUBLE DIAGNOSIS

PASSENGER COMPARTMENT

A
B
C
D
E
F
G
H
I
MTC
K
L
M

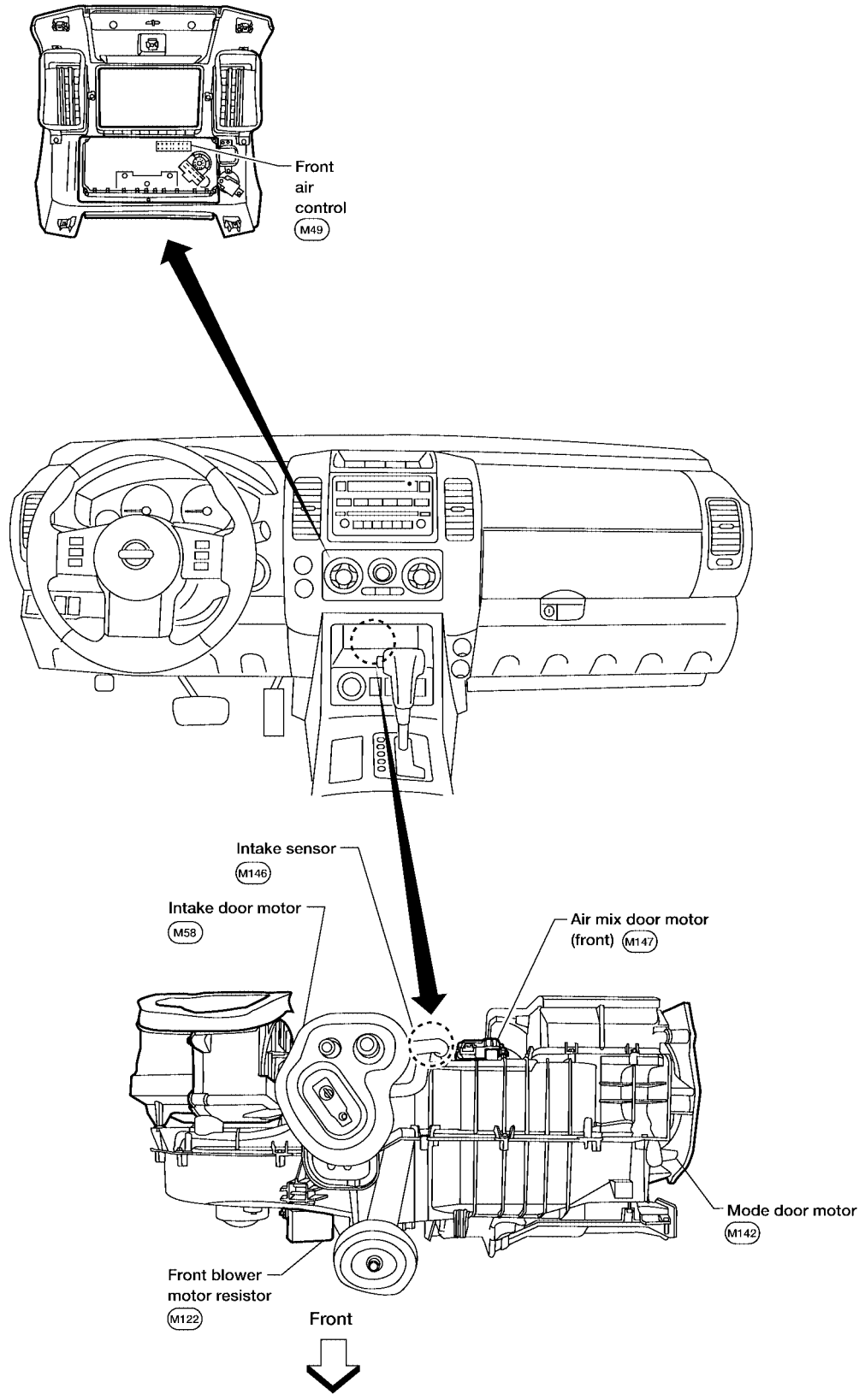

WJIA1301E

TROUBLE DIAGNOSIS

EJS004RI

Schematic

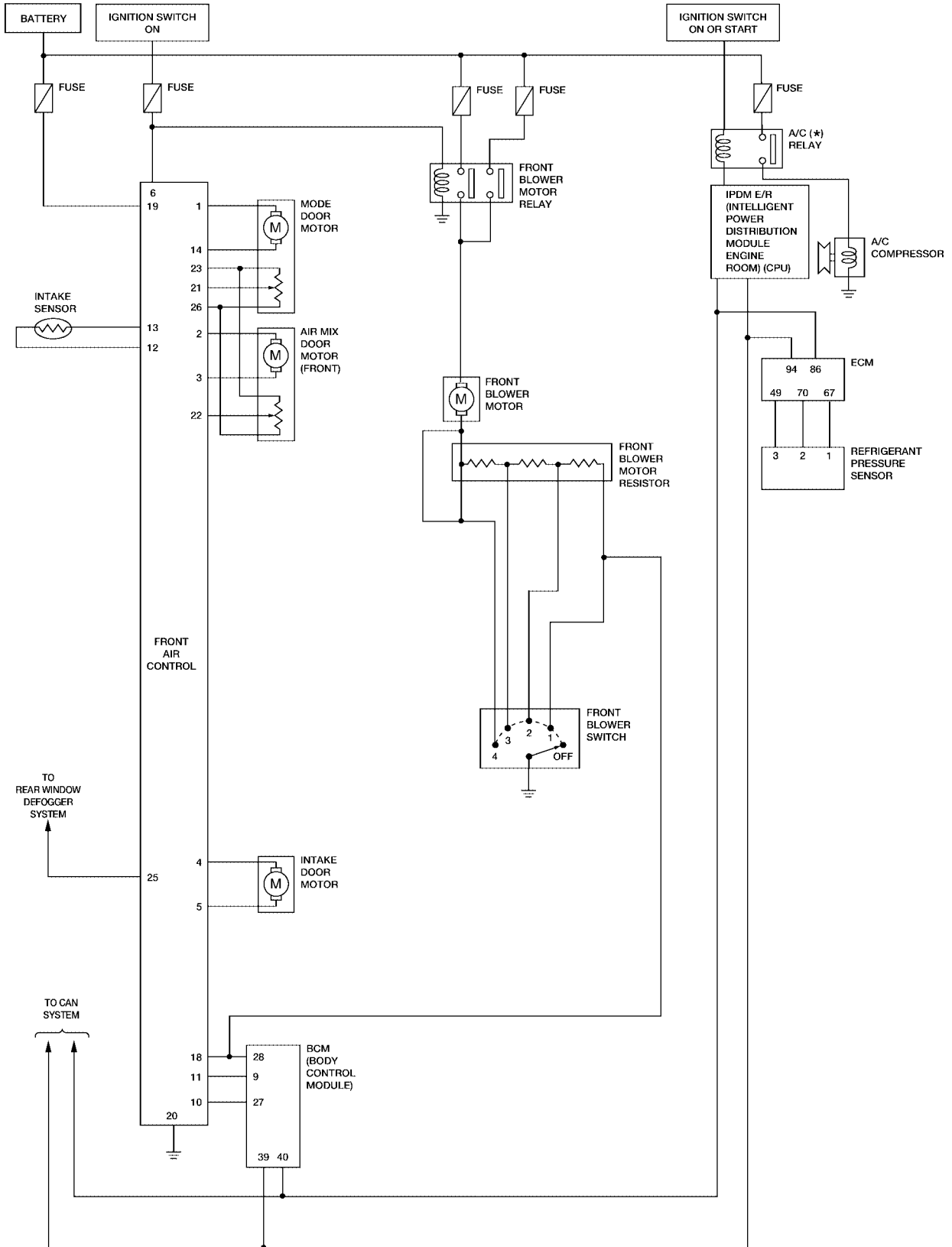

*: THIS RELAY IS BUILT INTO THE IPDM E/R (INTELLIGENT POWER DISTRIBUTION MODULE ENGINE ROOM)

WJWA0396E

TROUBLE DIAGNOSIS

Wiring Diagram — A/C,M —

EJS004RJ

MTC-A/C,M-01

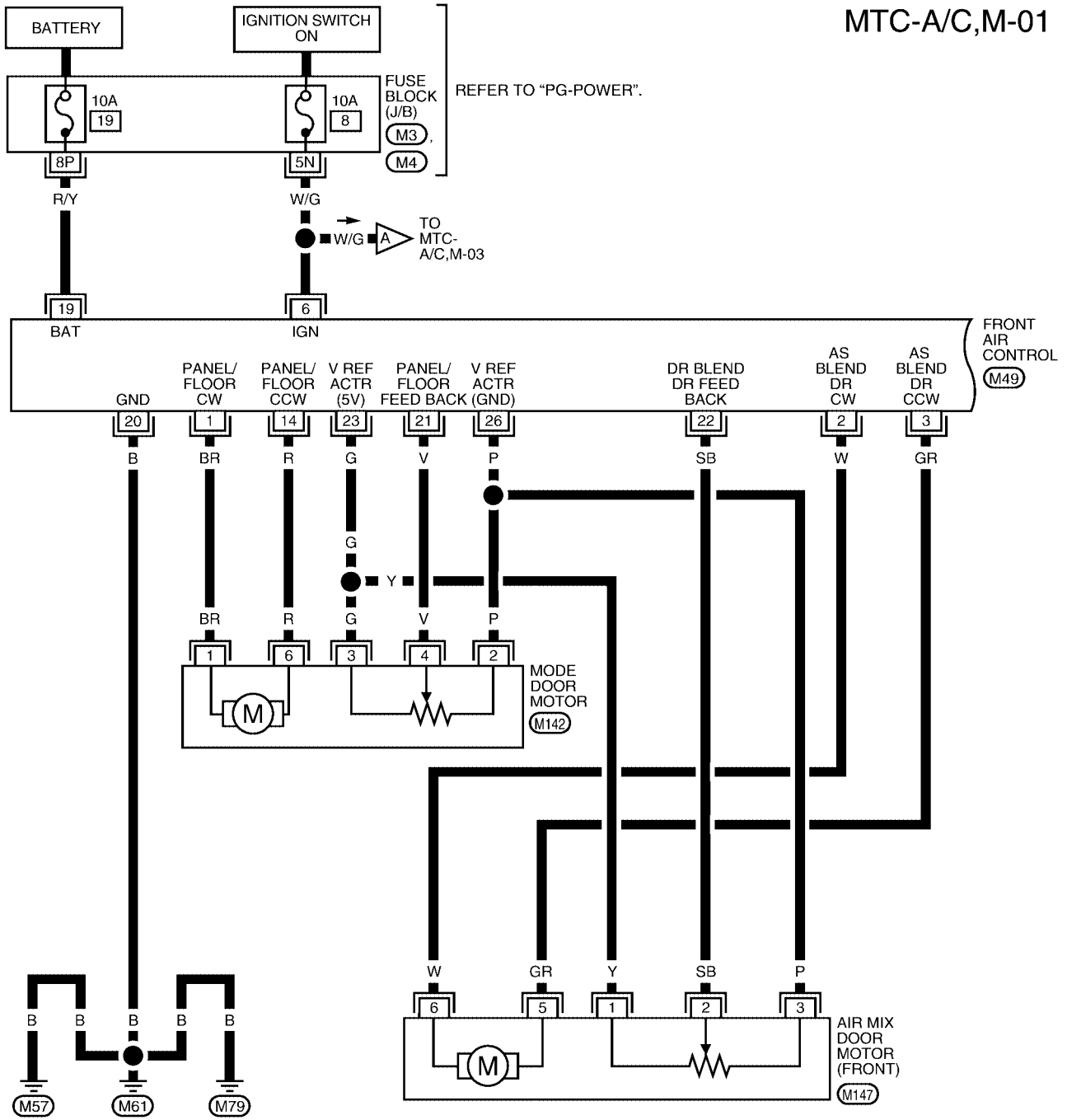

A
B
C
D
E
F
G
H
I
MTC
K
L
M

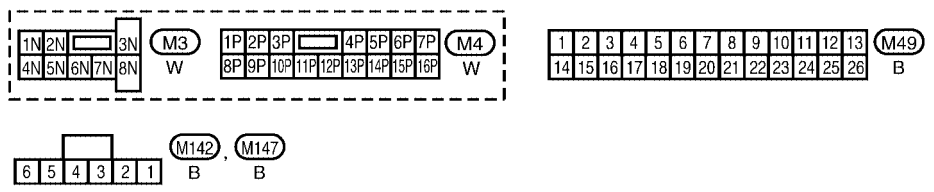

WJWA0397E

TROUBLE DIAGNOSIS

MTC-A/C,M-02

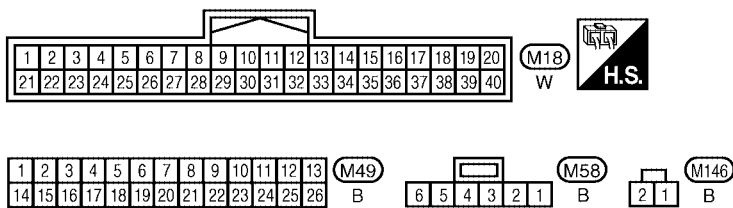
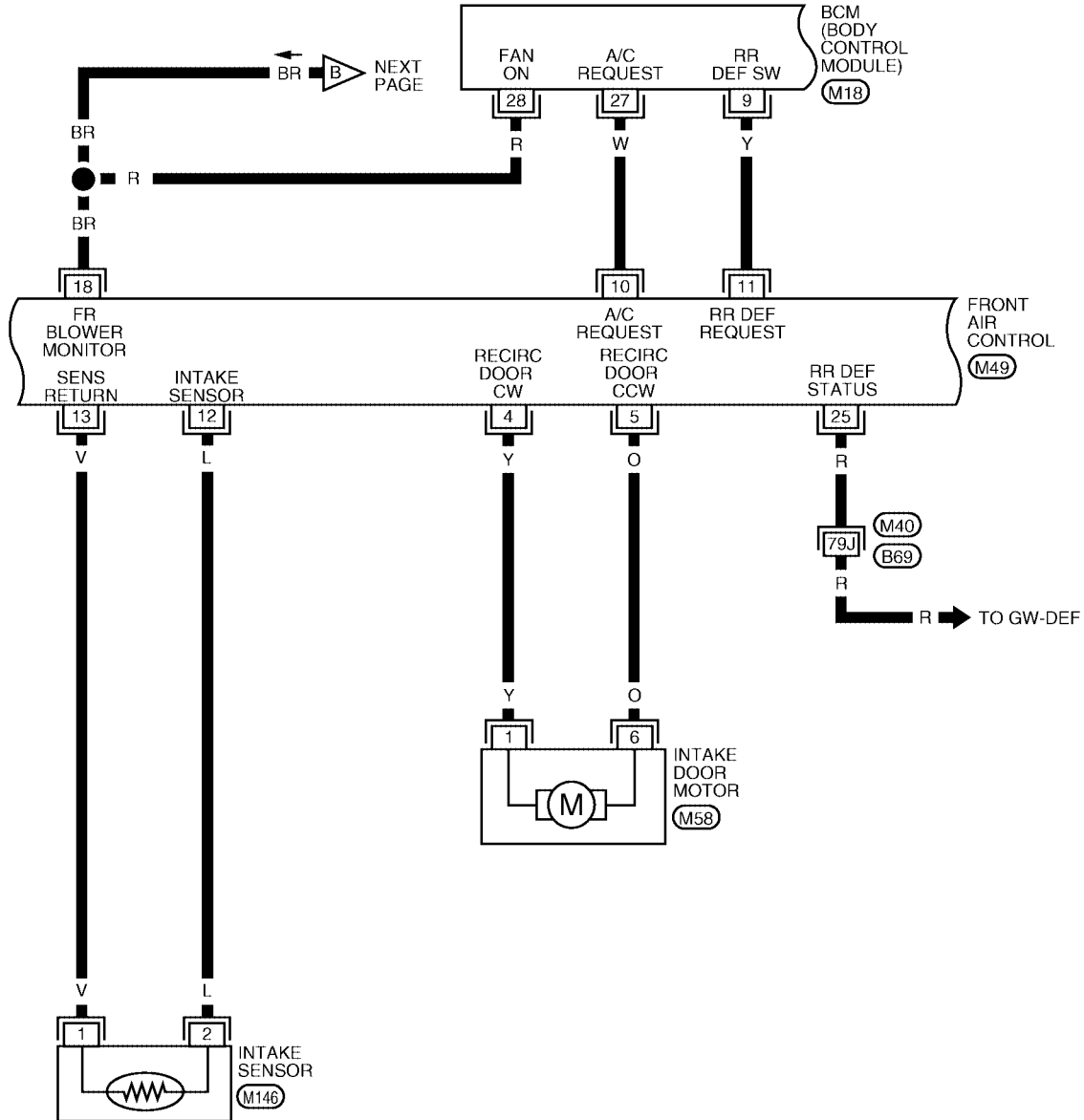

REFER TO THE FOLLOWING.
 (M40) - SUPER MULTIPLE JUNCTION (SMJ)

WJWA0280E

TROUBLE DIAGNOSIS

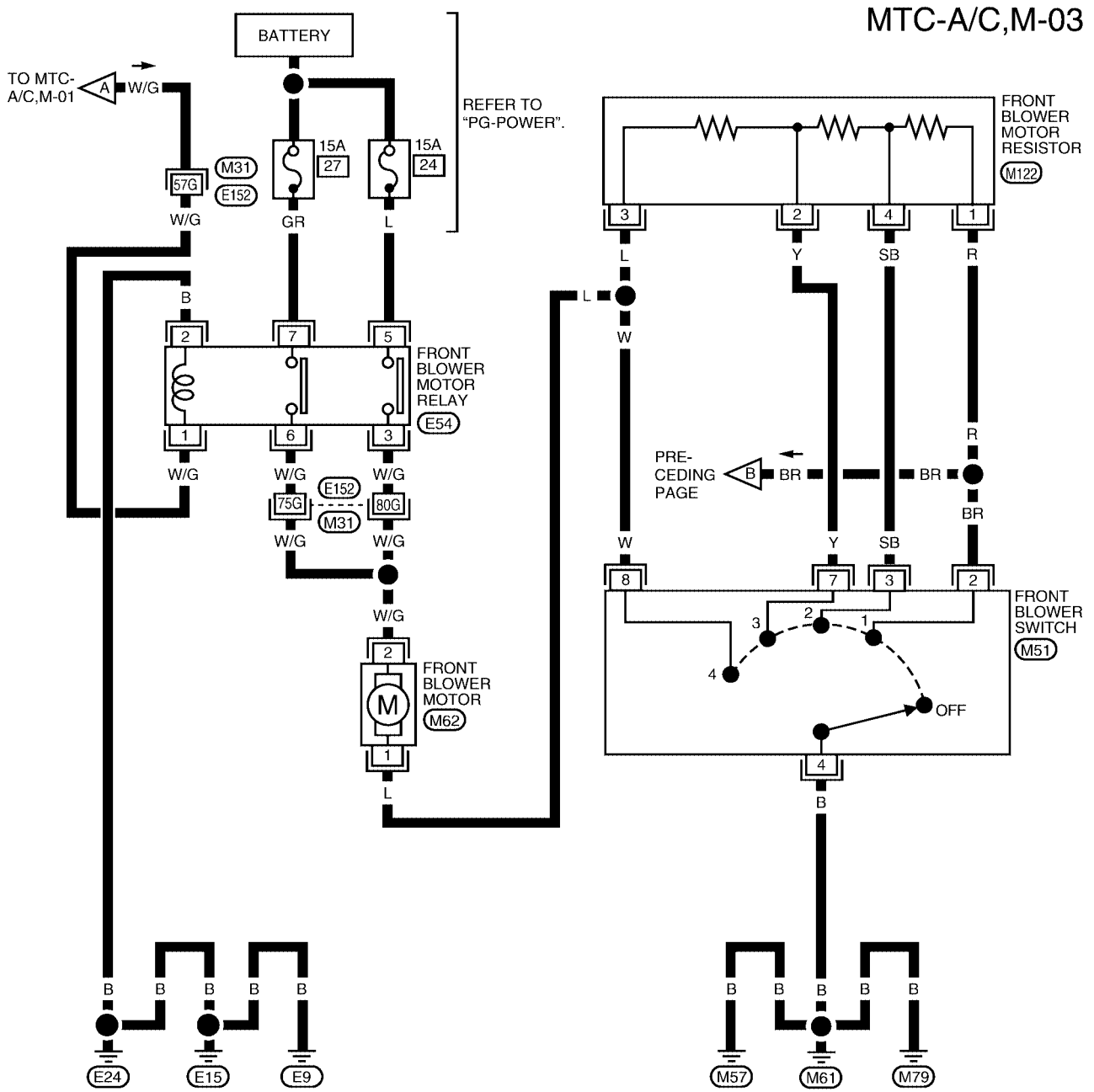

A
B
C
D
E
F
G
H
I
MTC
K
L
M

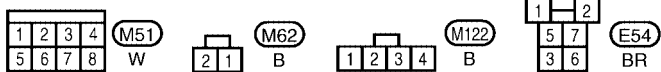

REFER TO THE FOLLOWING.
 (M31) - SUPER MULTIPLE JUNCTION (SMJ)

WJWA0281E

TROUBLE DIAGNOSIS

MTC-A/C, M-04

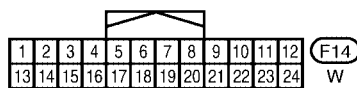
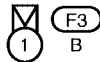
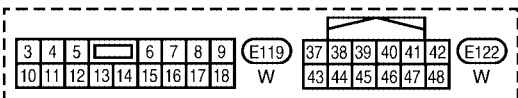
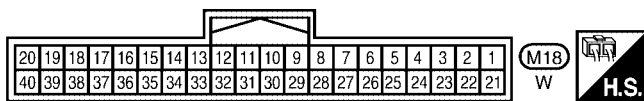
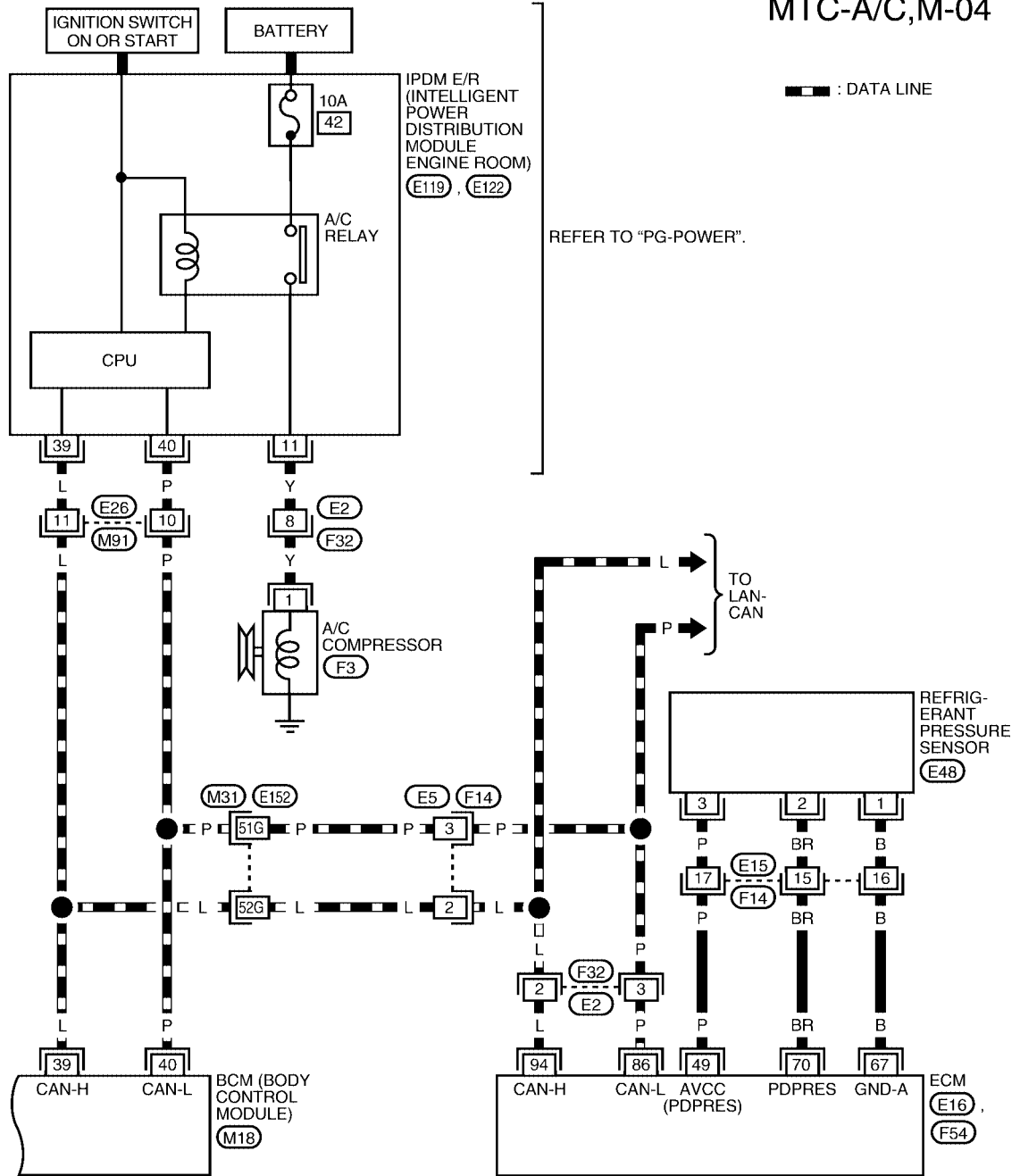

REFER TO THE FOLLOWING.
 (E16), (F54) - ELECTRICAL UNITS
 (M31) - SUPER MULTIPLE JUNCTION (SMJ)

WJWA0199E

TROUBLE DIAGNOSIS

EJS004RK

Front Air Control Terminals and Reference Value

Measure voltage between each terminal and ground by following Terminals and Reference Value for front air control.

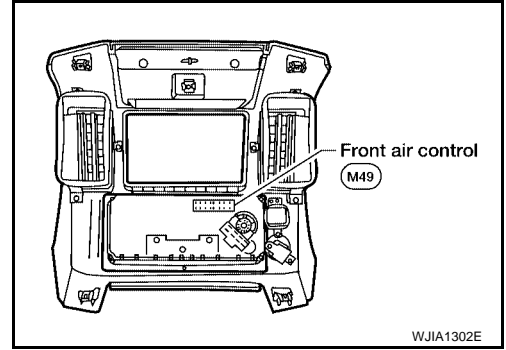

PIN CONNECTOR TERMINAL LAYOUT

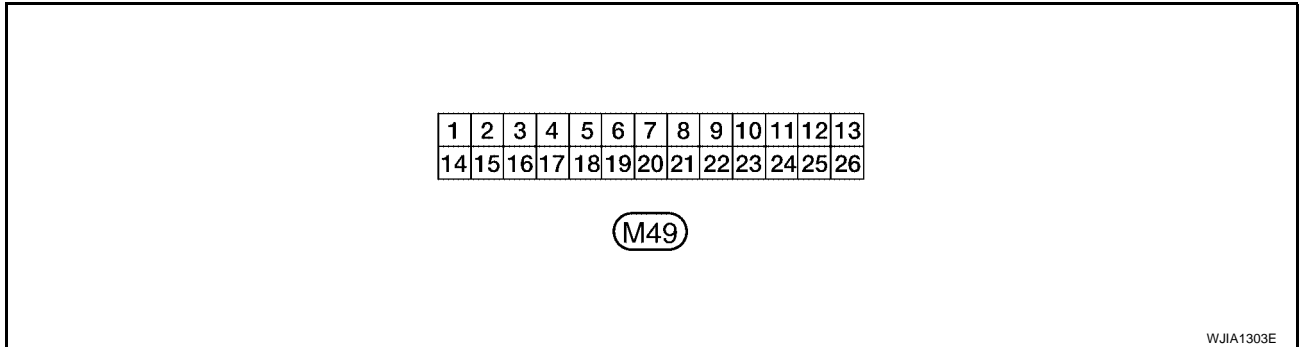

TERMINALS AND REFERENCE VALUE FOR FRONT AIR CONTROL

Terminal No.	Wire color	Item	Ignition switch	Condition	Voltage (V) (Approx.)
1	BR	Mode door motor CW	ON	Clockwise rotation	Battery voltage
2	W	Air mix door motor (Driver) CW	ON	Clockwise rotation	Battery voltage
3	G/R	Air mix door motor (Driver) CCW	ON	Counterclockwise rotation	Battery voltage
4	Y	Intake door motor CW	ON	Clockwise rotation	Battery voltage
5	O	Intake door motor CCW	ON	Counterclockwise rotation	Battery voltage
6	W/G	Power supply for IGN	ON	-	Battery voltage
10	W	Compressor ON signal	ON	A/C switch OFF	5V
			ON	A/C switch ON	0V
11	Y	Rear defrost request	ON	-	Battery voltage
12	L	Intake sensor	ON	-	0 - 5V
13	V	Sensor ground	ON	-	0 - 5V
14	R	Mode door motor CCW	ON	Counterclockwise rotation	Battery voltage
18	BR	Front blower monitor	ON	Front blower motor OFF	Battery voltage
				Front blower motor ON	0V
19	R/Y	Power supply for BAT	-	-	Battery voltage
20	B	Ground	-	-	0V
21	V	Mode door motor feedback	ON	-	0 - 5V
22	SB	Air mix door motor (Front) feedback	ON	-	0 - 5V
23	G	Power supply for mode door motor and air mix door motor (Front) PBR	ON	-	5V
25	R	Rear defroster request	ON	-	Battery voltage
26	P	Ground for mode door motor and air mix door motor (Front) PBR	ON	-	0V

TROUBLE DIAGNOSIS

EJS004RL

Operational Check

The purpose of the operational check is to confirm that the system operates properly.

Conditions : Engine running and at normal operating temperature

CHECKING BLOWER

1. Turn blower control dial clockwise. Blower should operate on low speed.
2. Turn the blower control dial again, and continue checking each blower speed until all speeds are checked.
3. Leave blower on speed 4.

If NG, go to trouble diagnosis procedure for [MTC-57, "Front Blower Motor Circuit"](#) .

If OK, continue with next check.

CHECKING DISCHARGE AIR



1. Turn the mode switch to each position.
2. Confirm that discharge air comes out according to the air distribution table.

Mode door position is checked in the next step.





If NG, go to trouble diagnosis procedure for [MTC-45, "Mode Door Motor Circuit"](#) .

If OK, continue with next check.

NOTE:



Confirm that the A/C compressor clutch is engaged (sound or visual inspection) and intake door position is at fresh when the DEF () or D/F () is selected.

DISCHARGE AIR FLOW

Mode door position	Air outlet/distribution		
	Vent	Foot	Defroster
	95%	5%	—
	60%	40%	—
	20%	55%	25%
	15%	50%	35%
	7%	15%	78%

Airflow always present at side demisters

CHECKING RECIRCULATION

1. Press recirculation () switch one time. Recirculation indicator should illuminate.
2. Press recirculation () switch one more time. Recirculation indicator should go off.
3. Listen for intake door position change (blower sound should change slightly).

If NG, go to trouble diagnosis procedure for [MTC-53, "Intake Door Motor Circuit"](#) .

If OK, continue with next check.

NOTE:

Confirm that the compressor clutch is engaged (sound or visual inspection) and intake door position is at fresh when the DEF or D/F is selected.

CHECKING TEMPERATURE DECREASE

1. Rotate temperature control dial counterclockwise.
2. Check for cold air at appropriate discharge air outlets.

If NG, listen for sound of air mix door motor operation if OK, go to trouble diagnosis procedure for [MTC-70, "Insufficient Cooling"](#) . If air mix door motor appears to be malfunctioning, go to [MTC-51, "DIAGNOSTIC PROCEDURE FOR AIR MIX DOOR MOTOR \(FRONT\)"](#) .

If OK, continue with next check.

CHECKING TEMPERATURE INCREASE

1. Rotate temperature control dial clockwise.
2. Check for hot air at appropriate discharge air outlets.

TROUBLE DIAGNOSIS

If NG, listen for sound of air mix door motor operation. If OK, go to trouble diagnosis procedure for [MTC-77, "Insufficient Heating"](#) . If air mix door motor (front) appears to be malfunctioning, go to [MTC-51, "DIAGNOSTIC PROCEDURE FOR AIR MIX DOOR MOTOR \(FRONT\)"](#) .

If OK, continue with next check.

CHECK A/C SWITCH

1. Press A/C switch with the blower switch ON.
2. A/C switch indicator will turn ON.
 - Confirm that the compressor clutch engages (sound or visual inspection).

If NG, go to trouble diagnosis procedure for [MTC-65, "Magnet Clutch Circuit"](#) .

If OK, continue with next check.

A

B

C

D

E

F

G

H

I

MTC

K

L

M

TROUBLE DIAGNOSIS

EJS004RM

Power Supply and Ground Circuit for Front Air Control

SYMPTOM: A/C system does not come on.

INSPECTION FLOW

1. Confirm symptom by performing the following operational check.

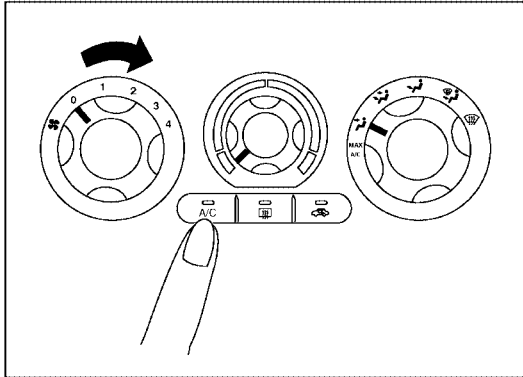

OPERATIONAL CHECK – AUTO mode

Blower must be on (1,2,3, or 4)

a. Press A/C switch

If OK (symptom cannot be duplicated), perform complete operational check (*2).
If NG (symptom is confirmed), continue with STEP-2 following.

2. Check for any service bulletins.

3. Check Main Power Supply and Ground Circuit. (*1)

4. Replace front air control (*3).

*1 [MTC-43. "DIAGNOSTIC PROCEDURE FOR A/C SYSTEM"](#)

*2 [ATC-53. "Operational Check \(Front\)"](#)

*3 [MTC-82. "FRONT AIR CONTROL"](#)

WJIA1498E

TROUBLE DIAGNOSIS

COMPONENT DESCRIPTION

Front Air Control

The front air control has a built-in microcomputer which processes information sent from various sensors needed for air conditioner operation. The air mix door motor, mode door motor, intake door motor, defroster door motor, blower motor and compressor are then controlled.

The front air control is unitized with control mechanisms. When the various switches and temperature dials are operated, data is input to the front air control.

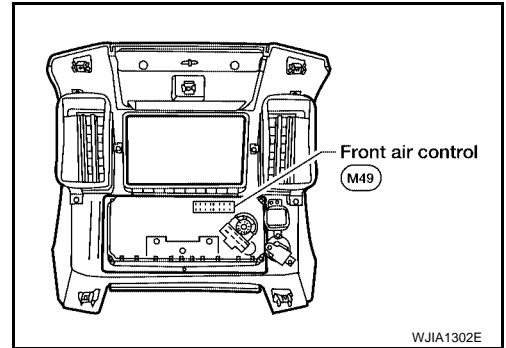

Potential Temperature Control (PTC)

The PTC is built into the front air control. It can be set from cold to hot or any intermediate position by rotating the temperature dial.

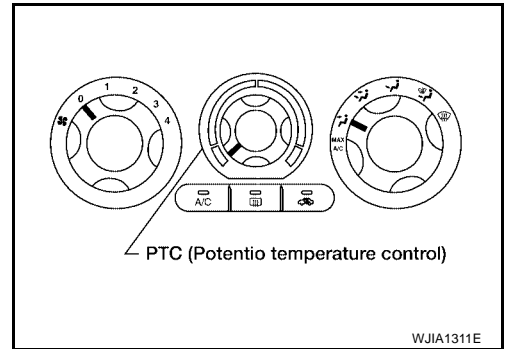

DIAGNOSTIC PROCEDURE FOR A/C SYSTEM

SYMPTOM: A/C system does not come on.

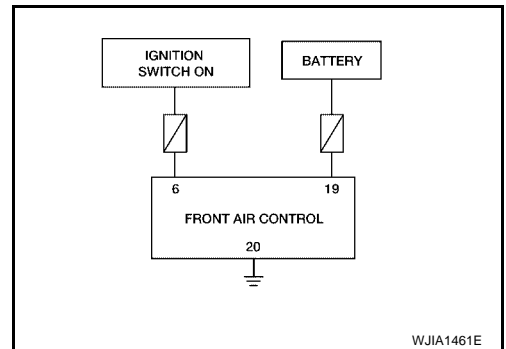

A
B
C
D
E
F
G
H
I
MTC
K
L
M

TROUBLE DIAGNOSIS

1. CHECK POWER SUPPLY CIRCUITS FOR FRONT AIR CONTROL

1. Turn ignition switch OFF.
2. Disconnect front air control connector.
3. Turn ignition switch ON.
4. Check voltage between front air control harness connector M49 terminals 6 and 19, and ground.

Terminals		(-)	Ignition switch position		
(+)	Terminal No.		OFF	ACC	ON
Front air control connector		Ground	Approx. 0V	Approx. 0V	Battery voltage
M49	6		Battery voltage	Battery voltage	Battery voltage
M49	19				

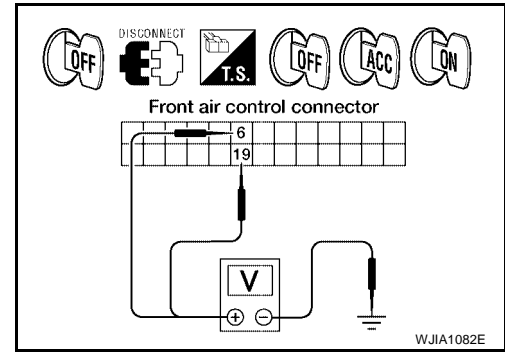

OK or NG

OK >> GO TO 2.

NG >> Check 10A fuses [Nos. 8 and 19, located in the fuse block (J/B)]. Refer to [PG-83](#).

- If fuses are OK, check harness for open circuit. Repair or replace as necessary.
- If fuses are NG, replace fuse and check harness for short circuit. Repair or replace as necessary.

2. CHECK GROUND CIRCUIT FOR FRONT AIR CONTROL

1. Turn ignition switch OFF.
2. Check continuity between front air control harness connector M49 terminal 20 and ground.

20 - Ground : Continuity should exist.

OK or NG

OK >> Replace front air control. Refer to [ATC-127, "FRONT AIR CONTROL"](#).

NG >> Repair harness or connector.

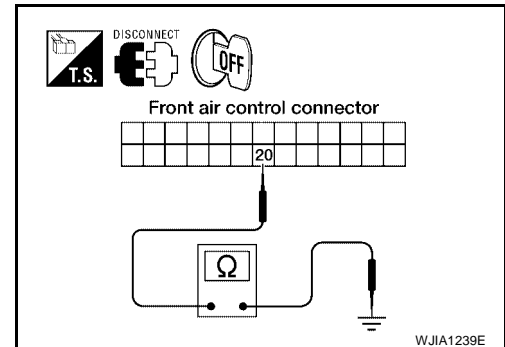

TROUBLE DIAGNOSIS

EJS004RN

Mode Door Motor Circuit

SYMPTOM:

- Air outlet does not change.
- Mode door motor does not operate normally.

INSPECTION FLOW

1. Confirm symptom by performing the following operational check.

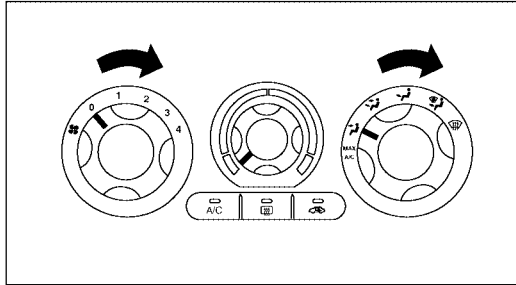

OPERATIONAL CHECK – Discharge air

- Turn blower control dial to 4.
- Rotate the mode switch to each position.

Discharge air flow

Mode door position	Air outlet/distribution		
	Vent	Foot	Defroster
	95%	5%	-
	60%	40%	-
	20%	55%	25%
	15%	50%	35%
	7%	15%	78%

Airflow always present at side demisters

- Confirm that discharge air comes out according to the air distribution table at left. Refer to "Discharge Air Flow" (*1).

NOTE:

- If OK (symptom cannot be duplicated), perform complete operational check (*2).
- If NG (symptom is confirmed), continue with STEP-2 following.
- Confirm that the compressor clutch is engaged (visual inspection) and intake door position is at FRESH when DEF or D/F is selected.

2. Check for any service bulletins.

3. Check mode door mechanism.

Check the PBR circuit (*3).

NG → Repair PBR circuit or replace motor.

YES

If the symptom still exists, perform a complete "Operational Table" (*2) and check for other symptoms. [Refer to Symptom Table" (*4).] Does another symptom exist?

YES

Go to Trouble Diagnosis for related symptom.

NO

Replace front air control (*5).

*1 [ATC-30, "Discharge Air Flow"](#)

*2 [ATC-53, "Operational Check \(Front\)"](#)

*3 [ATC-61, "DIAGNOSTIC PROCEDURE FOR MODE DOOR MOTOR"](#)

*4 [MTC-31, "SYMPTOM TABLE"](#)

*5 [MTC-82, "FRONT AIR CONTROL"](#)

WJIA1630E

SYSTEM DESCRIPTION

Component Parts

Mode door control system components are:

- Front air control

TROUBLE DIAGNOSIS

- Mode door motor
- PBR (built into mode door motor)
- Intake sensor

System Operation

The mode door position (vent, B/L, foot, D/F, and defrost) is set by the front air control by means of the mode door motor. When a mode door position is selected on the front air control, voltage is applied to one circuit of the mode door motor while ground is applied to the other circuit, causing the mode door motor to rotate. The direction of rotation is determined by which circuit has voltage applied to it, and which one has ground applied to it. The front air control monitors the mode door position by measuring the voltage signal on the PBR circuit.

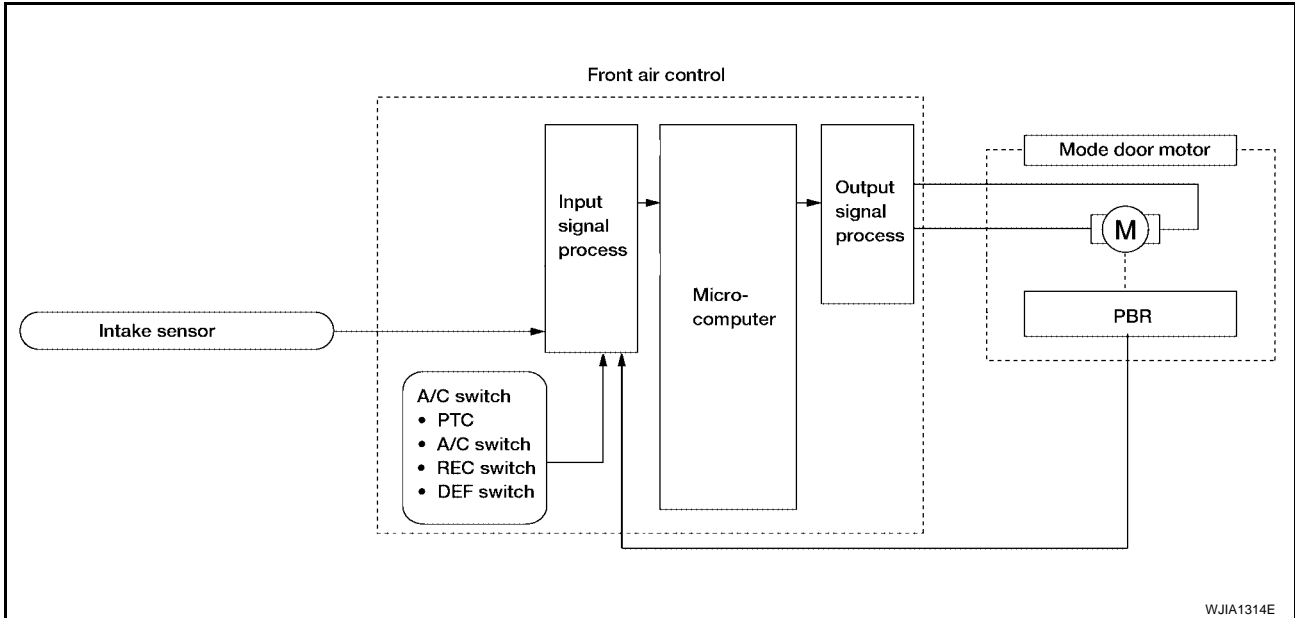

COMPONENT DESCRIPTION

Mode Door Motor

The mode door motor is attached to the heater and cooling unit assembly. It rotates so that air is discharged from the outlet as indicated by the front air control. Motor rotation is conveyed to a link which activates the mode door.

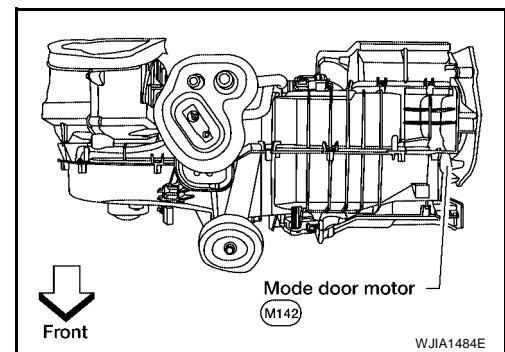

TROUBLE DIAGNOSIS

DIAGNOSTIC PROCEDURE FOR MODE DOOR MOTOR

1. CHECK POWER SUPPLY AND GROUND CIRCUITS FOR MODE DOOR MOTOR

1. Turn ignition switch OFF.
2. Disconnect front air control connector and mode door motor connector.
3. Check continuity between front air control harness connector M49 terminal 1 and mode door motor harness connector M142 terminal 1 and between front air control harness connector M49 terminal 14 and mode door motor harness connector M142 terminal 6.

1 - 1 : **Continuity should exist.**

14 - 6 : **Continuity should exist.**

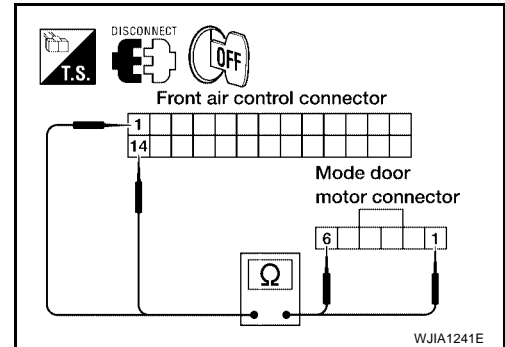

OK or NG

OK >> GO TO 2.

NG >> Repair or replace harness as necessary.

2. CHECK PBR REFERENCE SIGNAL VOLTAGE

1. Reconnect the front air control connector.
2. Turn ignition switch ON.
3. Check voltage between mode door motor harness connector M142 terminal 3 and ground.

3 - Ground : **Approx. 5V**

OK or NG

OK >> GO TO 4.

NG >> GO TO 3.

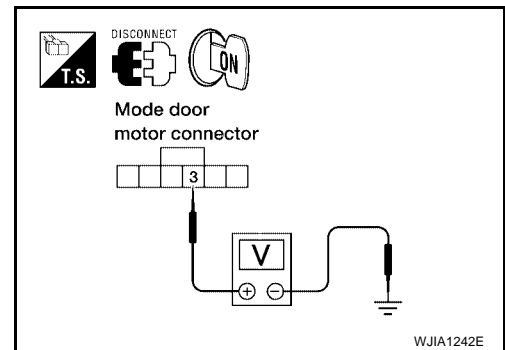

3. CHECK PBR REFERENCE VOLTAGE CIRCUIT BETWEEN MODE DOOR AND FRONT AIR CONTROL

1. Turn ignition switch OFF.
2. Disconnect the front air control connector.
3. Check continuity between mode door motor harness connector M142 terminal 3 and front air control harness connector M49 terminal 23.

3 - 23 : **Continuity should exist.**

OK or NG

OK >> Replace front air control. Refer to [ATC-127, "FRONT AIR CONTROL"](#).

NG >> Repair or replace harness as necessary.

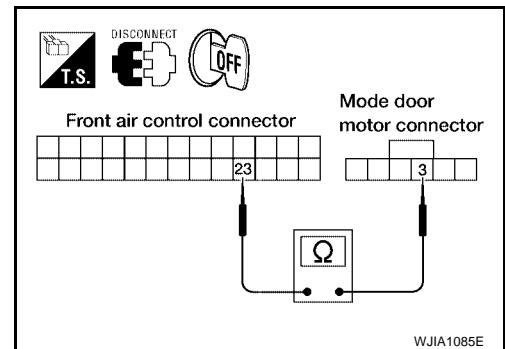

A
B
C
D
E
F
G
H
I
K
L
M

MTC

TROUBLE DIAGNOSIS

4. CHECK PBR GROUND REFERENCE CIRCUIT

1. Turn ignition switch OFF.
2. Disconnect the front air control connector.
3. Check continuity between mode door motor harness connector M142 terminal 2 and front air control harness connector M49 terminal 26.

2 - 26 : Continuity should exist.

OK or NG

- OK >> GO TO 5.
NG >> Repair or replace harness as necessary.

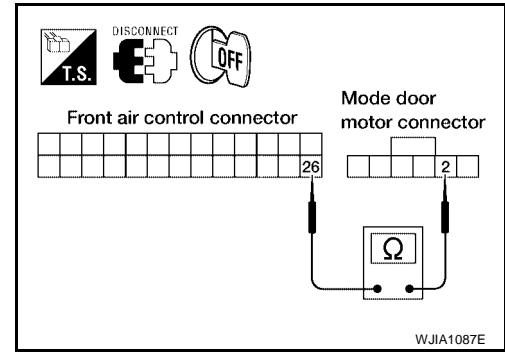

5. CHECK PBR FEEDBACK SIGNAL

1. Reconnect the front air control connector and mode door motor connector.
2. Turn ignition switch ON.
3. Check voltage between front air control harness connector M49 terminal 21 and ground.
4. Press mode switch through all modes.

21 - Ground : Approx. 0 - 5V

OK or NG

- OK >> Replace front air control. Refer to [ATC-127, "FRONT AIR CONTROL"](#).
NG >> GO TO 6.

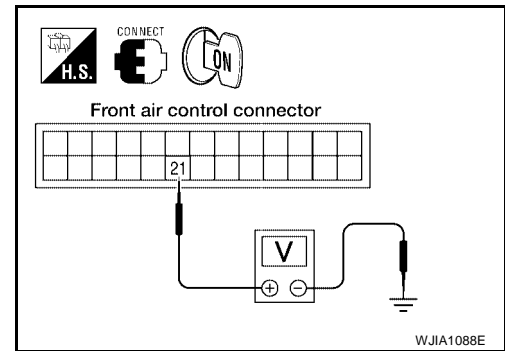

6. CHECK PBR FEEDBACK CIRCUIT

1. Turn ignition switch OFF.
2. Disconnect the mode door motor connector and front air control harness connector.
3. Check continuity between mode door motor harness connector M142 terminal 4 and front air control harness connector M49 terminal 21.

4 - 21 : Continuity should exist.

OK or NG

- OK >> Replace mode door motor. Refer to [ATC-144, "MODE DOOR MOTOR"](#).
NG >> Repair or replace harness as necessary.

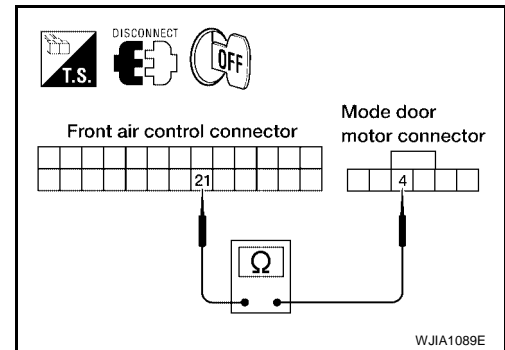

TROUBLE DIAGNOSIS

EJS004RO

Air Mix Door Motor Circuit

SYMPTOM:

- Discharge air temperature does not change.
- Air mix door motor does not operate.

INSPECTION FLOW

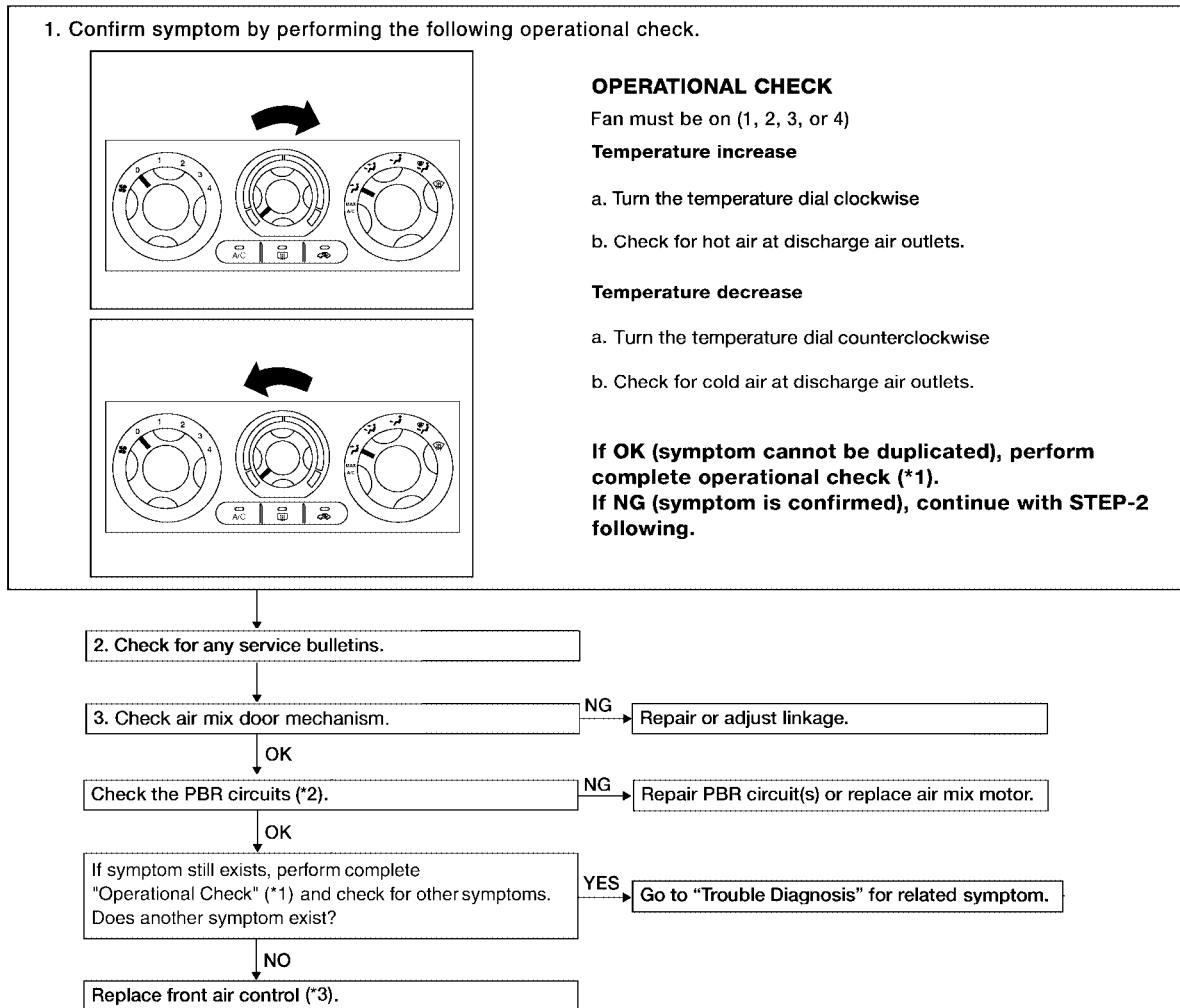

*1 [MTC-40. "Operational Check"](#)

*2 [MTC-51. "DIAGNOSTIC PROCEDURE FOR AIR MIX DOOR MOTOR \(FRONT\)"](#)

*3 [MTC-82. "FRONT AIR CONTROL"](#)

WJIA1500E

TROUBLE DIAGNOSIS

SYSTEM DESCRIPTION

Component Parts

Air mix door control system components are:

- Front air control
- Air mix door motor (front)
- PBR (built into air mix door motor)
- Intake sensor

System Operation

The front air control receives data from the temperature selected by the driver. The front air control then applies a voltage to one circuit of the air mix door motor, while ground is applied to the other circuit, causing the air mix door motor to rotate. The direction of rotation is determined by which circuit has voltage applied to it, and which one has ground applied to it. The front air control monitors the air mix door positions by measuring the voltage signal on the PBR circuits of each door.

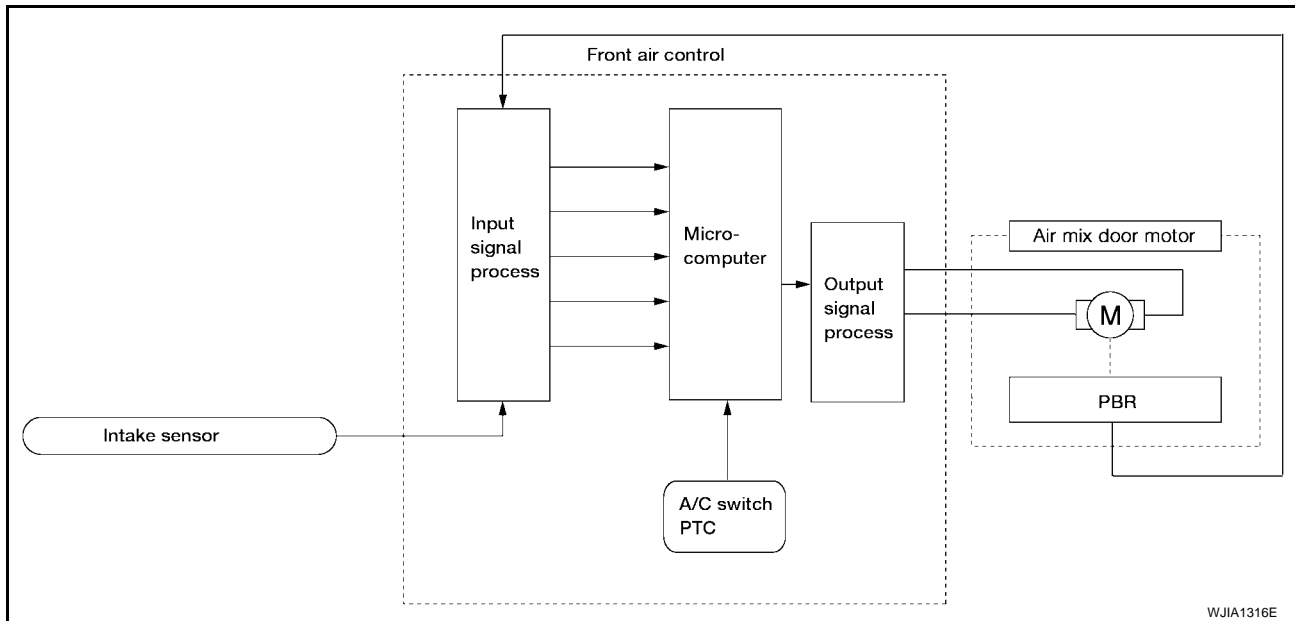

Air Mix Door Control Specification

COMPONENT DESCRIPTION

Air Mix Door Motors

The air mix door motor is attached to the front heater and cooling unit assembly. This motor rotates so that the air mix door is opened or closed to a position set by the front air control. Motor rotation is then conveyed through a shaft and the air mix door position is then fed back to the front air control by the PBR built into the air mix door motor.

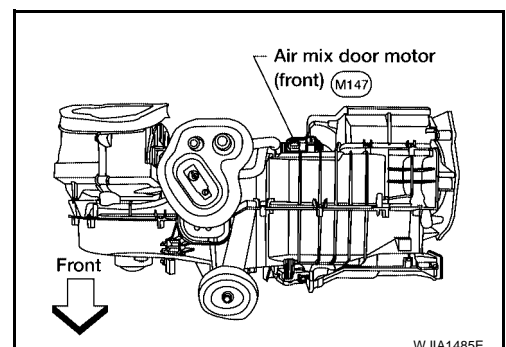
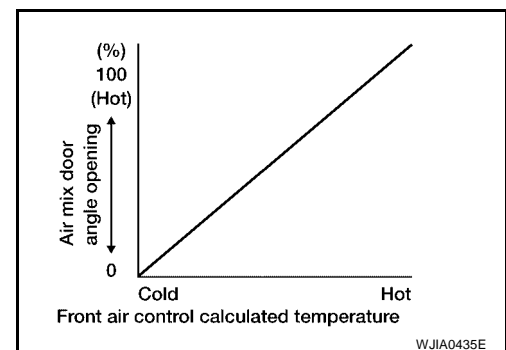

TROUBLE DIAGNOSIS

DIAGNOSTIC PROCEDURE FOR AIR MIX DOOR MOTOR (FRONT)

1. CHECK POWER SUPPLY CIRCUITS FOR AIR MIX DOOR MOTOR

1. Turn ignition switch OFF.
2. Disconnect front air control connector and air mix door motor (front) connector.
3. Check continuity between front air control harness connector M49 terminal 2 and 3 and air mix door motor (front) harness connector M147 terminal 6 and 5.

2 - 6 : Continuity should exist.
3 - 5 : Continuity should exist.

OK or NG

- OK >> GO TO 2.
 NG >> Repair or replace harness as necessary.

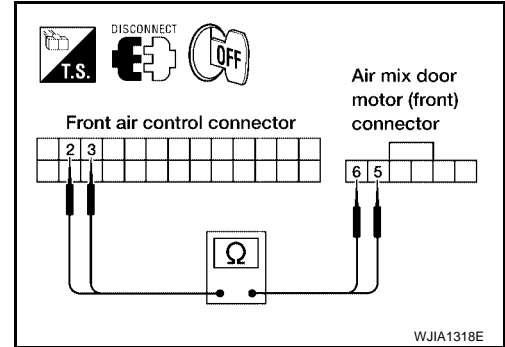

2. CHECK PBR REFERENCE SIGNAL VOLTAGE

1. Reconnect the front air control connector.
2. Turn ignition switch ON.
3. Check voltage between air mix door motor (front) harness connector M147 terminal 1 and ground.

1 - Ground : Approx. 5V

OK or NG

- OK >> GO TO 4.
 NG >> GO TO 3.

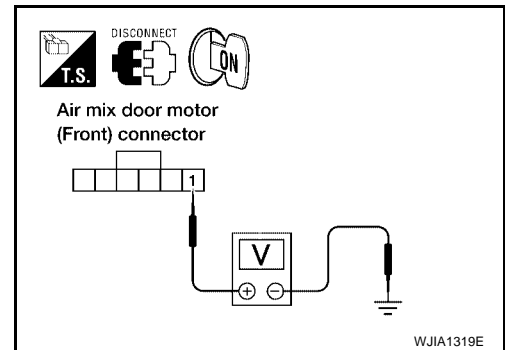

3. CHECK PBR REFERENCE VOLTAGE CIRCUIT BETWEEN AIR MIX DOOR MOTOR (FRONT) AND FRONT AIR CONTROL

1. Turn ignition switch OFF.
2. Disconnect the front air control connector.
3. Check continuity between air mix door motor (front) harness connector M147 (B) terminal 1 and front air control harness connector M49 (A) terminal 23.

A		B		Continuity
Connector	Terminal	Connector	Terminal	
Front air control: M49	23	Air mix door motor (front): M143	1	Yes

OK or NG

- OK >> Replace front air control. Refer to [ATC-127, "FRONT AIR CONTROL"](#).
 NG >> Repair or replace harness as necessary.

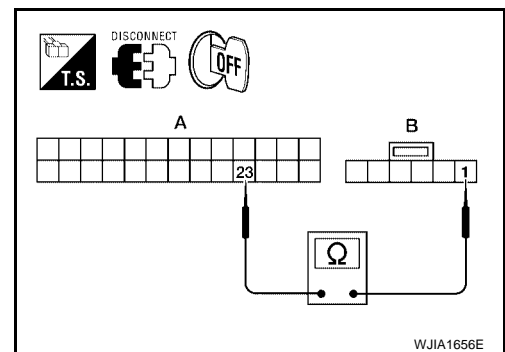

A
B
C
D
E
F
G
H
I
MTC
K
L
M

TROUBLE DIAGNOSIS

4. CHECK PBR GROUND REFERENCE CIRCUIT

1. Turn ignition switch OFF.
2. Disconnect the front air control connector.
3. Check continuity between air mix door motor (front) harness connector M147 terminal 3 and front air control harness connector M49 terminal 26.

3 - 26 : Continuity should exist.

OK or NG

- OK >> GO TO 5.
NG >> Repair or replace harness as necessary.

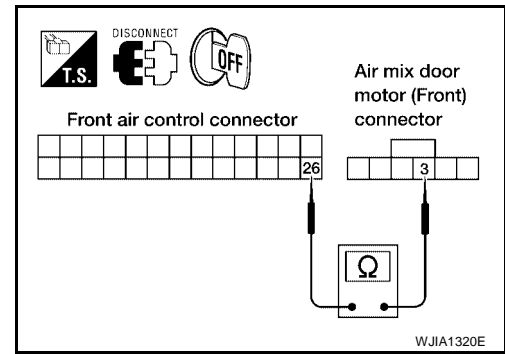

5. CHECK PBR FEEDBACK SIGNAL

1. Reconnect the front air control connector and air mix door motor (front) connector.
2. Turn ignition switch ON.
3. Check voltage between front air control harness connector M49 terminal 22 and ground.
4. Rotate temperature control dial through complete range.

22 - Ground : Approx. 0V - 5V

OK or NG

- OK >> Replace front air control. Refer to [ATC-127, "FRONT AIR CONTROL"](#) .
NG >> GO TO 6.

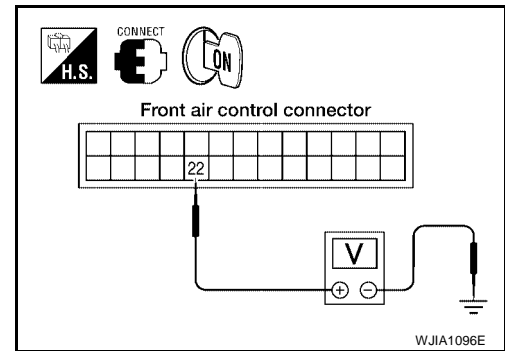

6. CHECK PBR FEEDBACK CIRCUIT

1. Turn ignition switch OFF.
2. Disconnect the air mix door motor (front) connector and front air control connector.
3. Check continuity between air mix door motor (front) harness connector M147 terminal 2 and front air control harness connector M49 terminal 22.

2 - 22 : Continuity should exist.

OK or NG

- OK >> Replace air mix door motor (front). Refer to [MTC-92, "AIR MIX DOOR MOTOR"](#) .
NG >> Repair or replace harness as necessary.

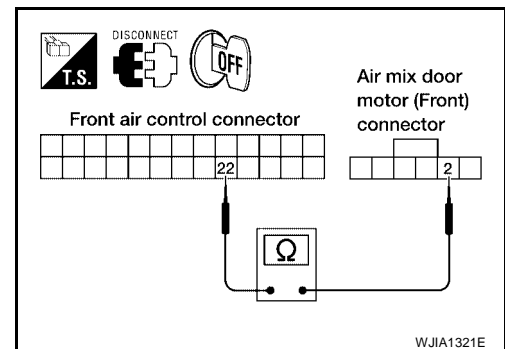

TROUBLE DIAGNOSIS

EJS004RP

Intake Door Motor Circuit

SYMPTOM:

- Intake door does not change.
- Intake door motor does not operate normally.

INSPECTION FLOW

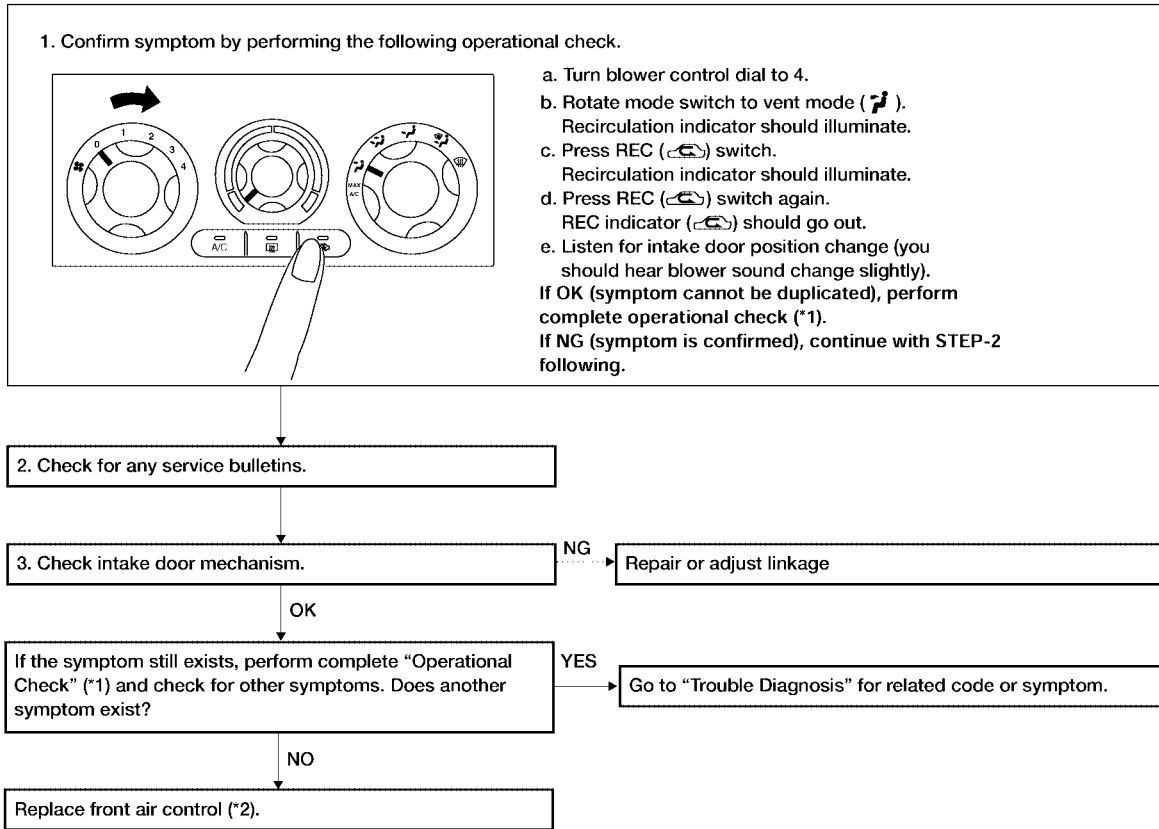

*1 [ATC-53. "Operational Check \(Front\)"](#) *2 [MTC-82. "FRONT AIR CONTROL"](#)

WJIA1477E

TROUBLE DIAGNOSIS

SYSTEM DESCRIPTION

Component Parts

Intake door control system components are:

- Front air control
- Intake door motor
- Intake sensor

System Operation

The intake door control determines the intake door position based on the position of the recirculation switch. When the recirculation switch is depressed the intake door motor rotates closing off the fresh air inlet and recirculating the cabin air. If the recirculation switch is depressed again, the intake door motor rotates in the opposite direction, again allowing fresh air into the cabin.

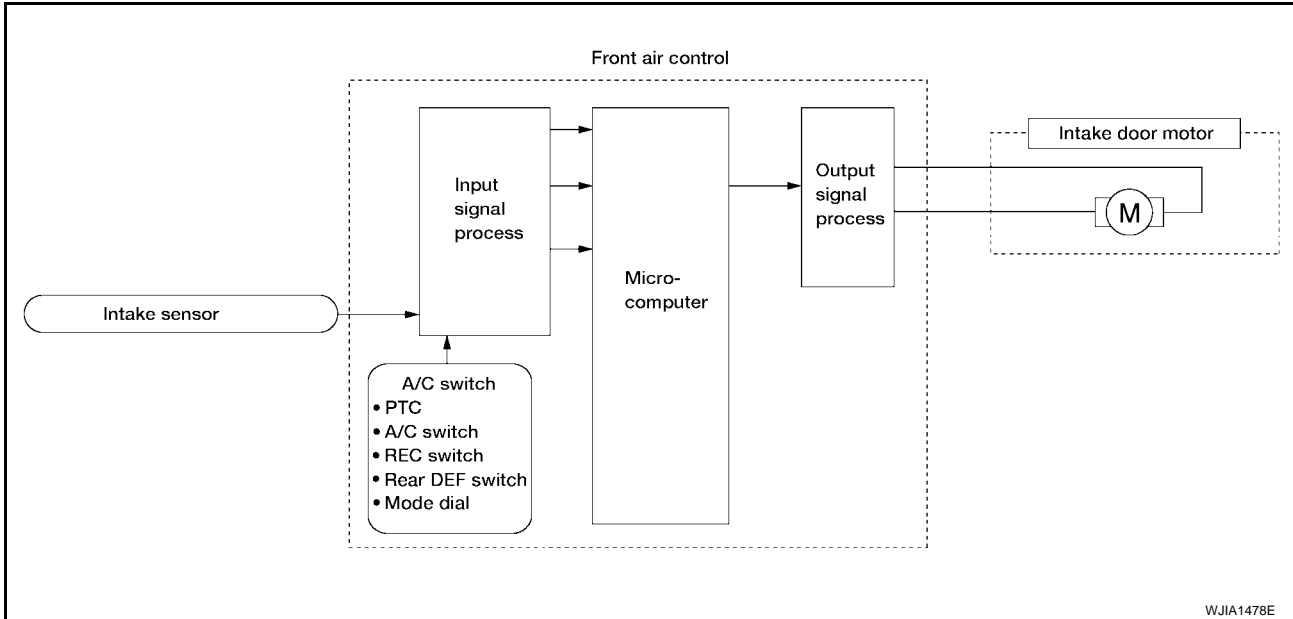

COMPONENT DESCRIPTION

Intake door motor

The intake door motor is attached to the intake unit. It rotates so that air is drawn from inlets set by the front air control. Motor rotation is conveyed to a lever which activates the intake door.

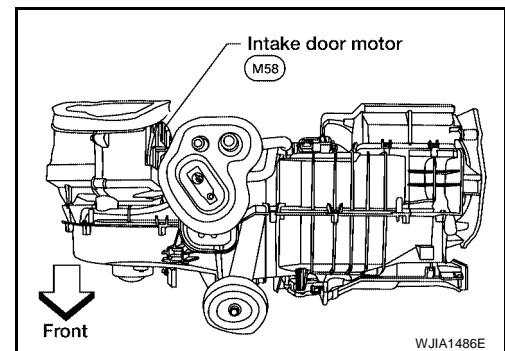

TROUBLE DIAGNOSIS

DIAGNOSTIC PROCEDURE FOR INTAKE DOOR MOTOR

1. CHECK INTAKE DOOR MOTOR CIRCUIT VOLTAGE

1. Turn ignition switch OFF.
2. Disconnect intake door motor connector.
3. Turn ignition switch ON.
4. Rotate the temperature control dial counterclockwise.
5. Check voltage between intake door motor harness connector M58 terminal 6 and ground.

6 - Ground : **Battery voltage**

OK or NG

- OK >> GO TO 3.
NG >> GO TO 2.

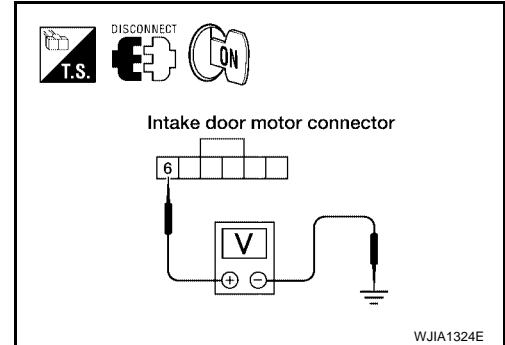

2. CHECK INTAKE DOOR MOTOR CIRCUIT FOR OPEN

1. Turn ignition switch OFF.
2. Disconnect front air control connector.
3. Check continuity between front air control harness connector M49 terminal 5 and intake door motor harness connector M58 terminal 6.

5 - 6 : **Continuity should exist.**

OK or NG

- OK >> Replace front air control connector. Refer to [MTC-82, "CONTROL UNIT"](#).
NG >> Repair or replace harness as necessary.

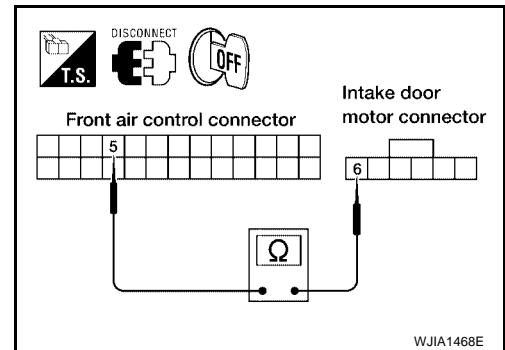

3. CHECK INTAKE DOOR MOTOR CIRCUIT VOLTAGE

1. Rotate the temperature control dial clockwise.
2. Check voltage between intake door motor harness connector M58 terminal 1 and ground.

1 - Ground : **Battery voltage**

OK or NG

- OK >> Replace intake door motor. Refer to [ATC-143, "INTAKE DOOR MOTOR"](#).
NG >> GO TO 4.

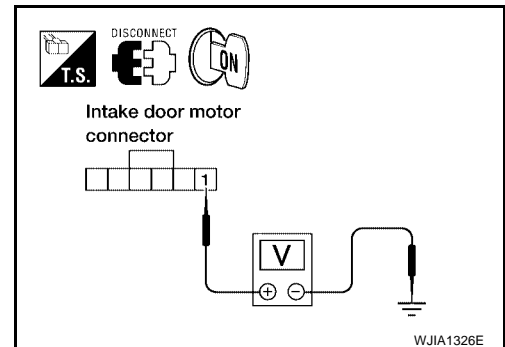

A
B
C
D
E
F
G
H
I
MTC
K
L
M

TROUBLE DIAGNOSIS

4. CHECK INTAKE DOOR MOTOR CIRCUIT FOR OPEN

1. Turn ignition switch OFF.
2. Disconnect front air control connector.
3. Check continuity between front air control harness connector M49 (A) terminal 4 and intake door motor harness connector M58 (B) terminal 1.

A		B		Continuity
Connector	Terminal	Connector	Terminal	
Front air control: M49	4	Intake door motor: M58	1	Yes

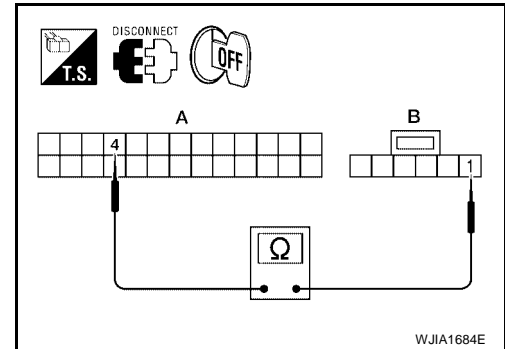

OK or NG

- OK >> Replace front air control connector. Refer to [MTC-82, "CONTROL UNIT"](#) .
- NG >> Repair or replace harness as necessary.

TROUBLE DIAGNOSIS

EJS004RQ

Front Blower Motor Circuit

SYMPTOM:

- Blower motor operation is malfunctioning.

INSPECTION FLOW

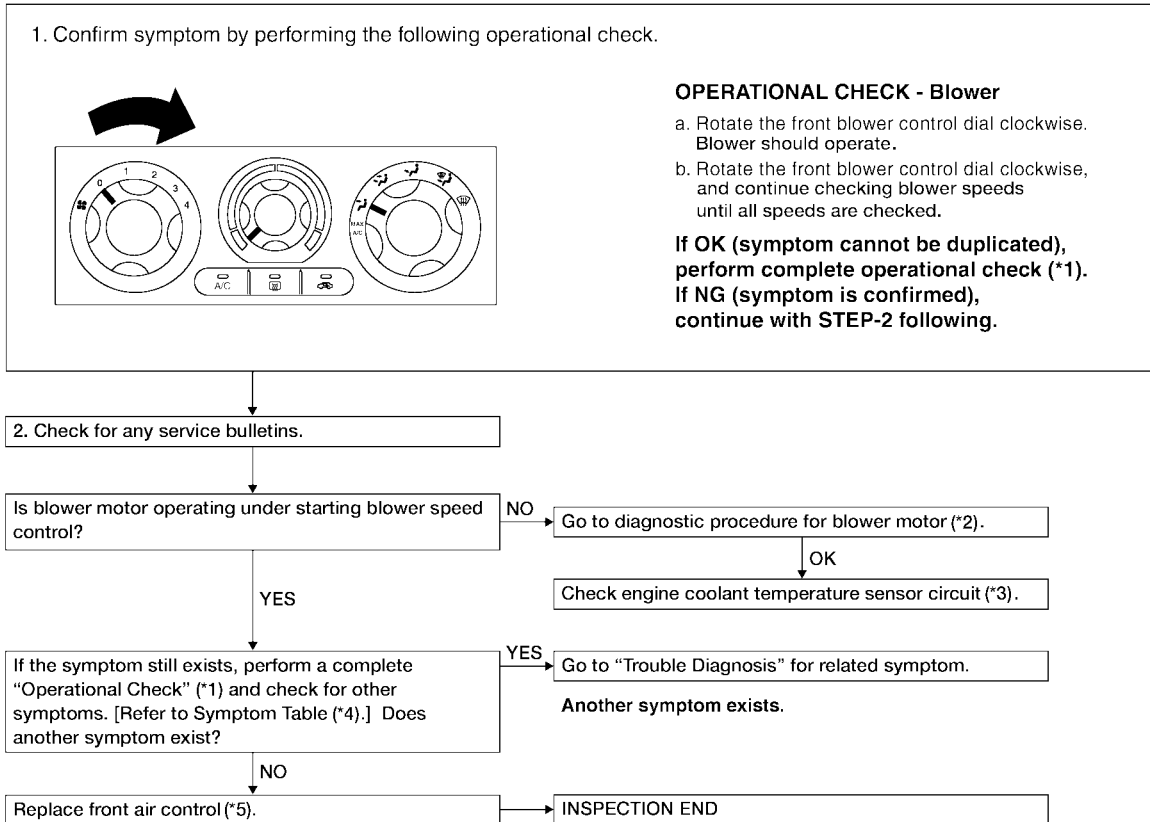

*1 [MTC-40. "Operational Check"](#)

*2 [MTC-59. "DIAGNOSTIC PROCEDURE FOR BLOWER MOTOR"](#)

*3 [EC-207. "DTC P0117, P0118 ECT SENSOR"](#)

*4 [MTC-31. "SYMPTOM TABLE"](#)

*5 [MTC-82. "FRONT AIR CONTROL"](#)

WJIA1501E

TROUBLE DIAGNOSIS

SYSTEM DESCRIPTION

Component Parts

Blower speed control system components are:

- Front air control
- Front blower motor resistor
- Front blower motor
- Front blower relay

System Operation

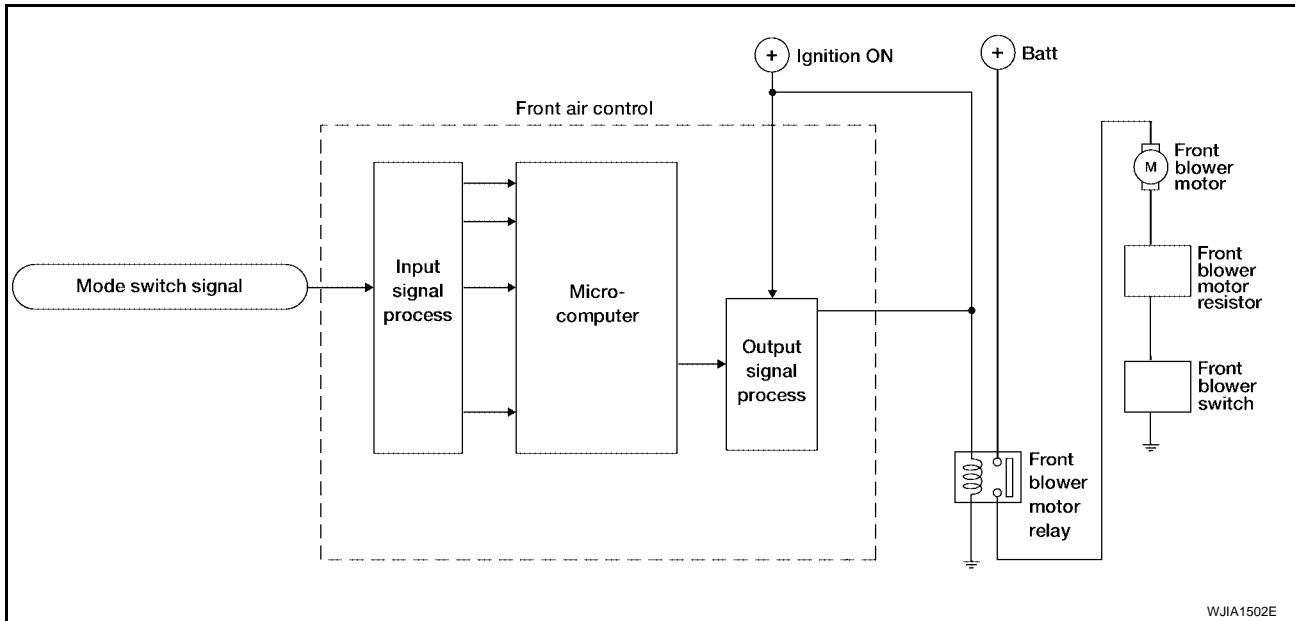

COMPONENT DESCRIPTION

Blower Motor Resistor

The front blower motor resistor is located on the heater and cooling unit assembly. The front blower motor resistor grounds the front blower motor through a series of 1, 2, or 3 resistors, depending upon speed selected. For high speed operation the front blower motor resistor is circumvented and the front blower motor grounds directly.

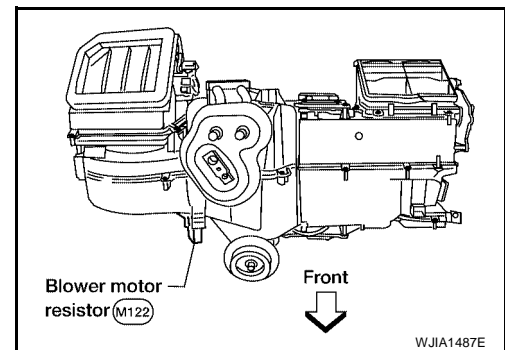

TROUBLE DIAGNOSIS

DIAGNOSTIC PROCEDURE FOR BLOWER MOTOR

SYMPTOM: Blower motor operation is malfunctioning under starting blower speed control.

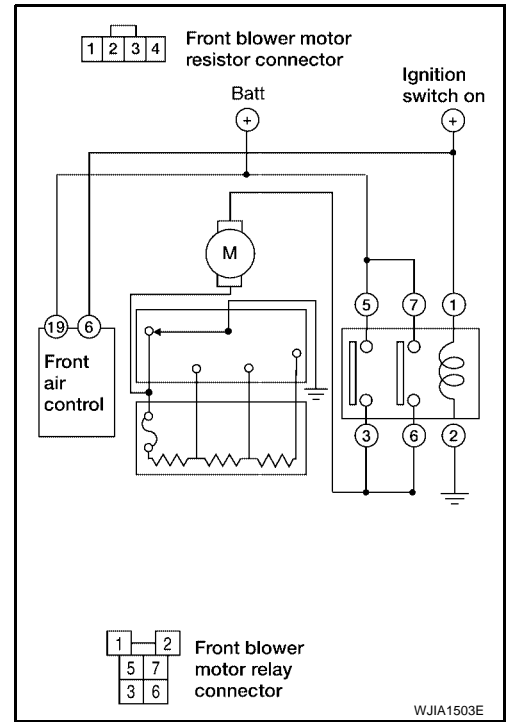

1. DIAGNOSTIC PROCEDURE

1. Turn ignition switch ON.
2. Turn the front blower switch to each of its four speeds.
Does blower motor rotate normally at each speed?

YES or NO

- YES >> Inspection End.
NO >> 1. Does not rotate at any speed, GO TO 2.
2. Does not rotate at 1 - 3 speed, GO TO 13.
3. Does not rotate at 4 speed, GO TO 16.

2. CHECK FUSES

1. Check 15A fuses (Nos. 24 and 27, located in the fuse and fusible link box). Refer to [PG-84, "FUSE AND FUSIBLE LINK BOX"](#).
2. Check 10A fuse [No. 8, located in the fuse block (JB)]. Refer to [PG-83, "FUSE BLOCK-JUNCTION BOX \(J/B\)"](#).

OK or NG

- OK >> GO TO 3.
NG >> GO TO 8.

TROUBLE DIAGNOSIS

3. CHECK FRONT BLOWER MOTOR POWER SUPPLY

1. Turn ignition switch OFF.
2. Disconnect front blower motor harness connector.
3. Turn ignition switch ON.
4. Select any front blower speed except OFF.
5. Check voltage between front blower motor harness connector M62 terminal 2 and ground.

2 - Ground : Battery voltage

OK or NG

- OK >> GO TO 12.
 NG >> GO TO 4.

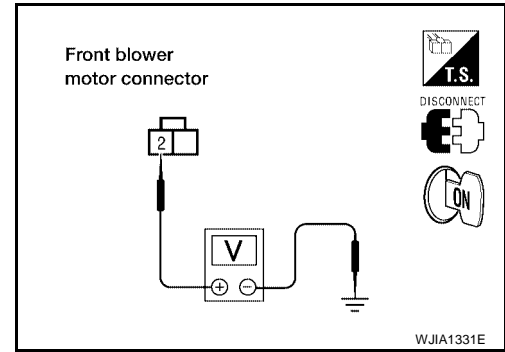

4. CHECK FRONT BLOWER MOTOR RELAY

1. Turn Ignition switch OFF.
2. Check front blower motor relay. Refer to [MTC-63, "Front Blower Motor Relay"](#).

OK or NG

- OK >> GO TO 5.
 NG >> Replace front blower motor relay.

5. CHECK FRONT BLOWER MOTOR RELAY POWER SUPPLY (SWITCH SIDE)

Check voltage between front blower motor relay harness connector E54 terminals 7 and 5 and ground.

A			Condition	Voltage (Approx.)
(+)	Terminal	(-)		
Front air control connector				
M54	5	Ground	Blower motor relay power supply	Battery voltage
M54	7	Ground	Blower motor relay power supply	Battery voltage

OK or NG

- OK >> GO TO 6.
 NG >> Repair harness or connector.

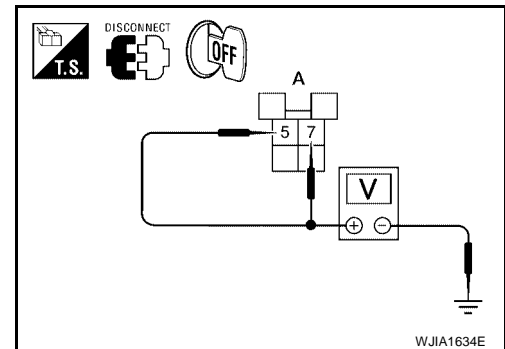

TROUBLE DIAGNOSIS

6. CHECK FRONT BLOWER MOTOR RELAY POWER SUPPLY (COIL SIDE)

1. Turn ignition switch ON.
2. Check voltage between front blower motor relay harness connector E54 terminal 1 and ground.

A			Condition	Voltage (Approx.)
(+)		(-)		
Front air control connector	Terminal			
M54	1	Ground	Blower motor relay power supply (coil side)	Battery voltage

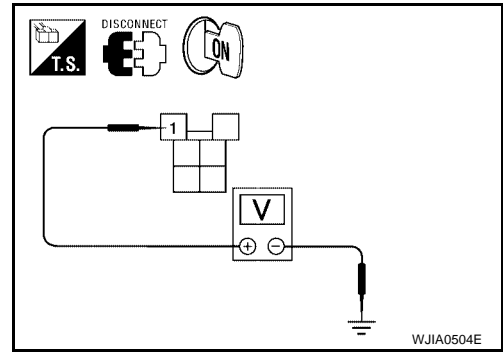

OK or NG

- OK >> GO TO 7.
 NG >> Repair or replace harness as necessary.

7. CHECK FRONT BLOWER MOTOR POWER FROM RELAY TO FRONT BLOWER MOTOR

1. Turn ignition switch OFF.
2. Check continuity between front blower motor relay harness connector E54 terminals 6 and 3 and front blower motor harness connector M62 terminal 2.

3, 6 - 2 : Continuity should exist.

OK or NG

- OK >> Repair or replace harness as necessary.
 NG >> Repair harness or connector between the front blower motor relay and the front blower motor.

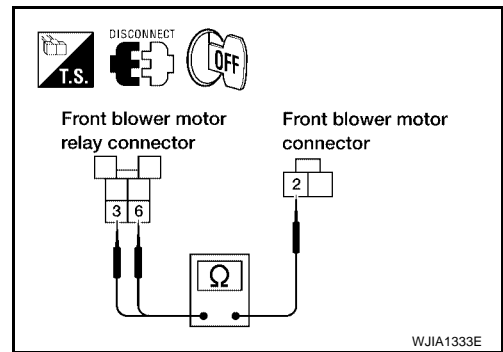

8. REPLACE FUSE

Refer to [PG-84, "FUSE AND FUSIBLE LINK BOX"](#) .

Does fuse No. 24 or 27 open when the front blower motor is turned on?

YES or NO

- YES >> GO TO 10.
 NO >> GO TO 9.

9. REPLACE FUSE

Refer to [PG-83, "FUSE BLOCK-JUNCTION BOX \(J/B\)"](#) .

Does fuse No. 8 open when the ignition switch is turned ON?

YES or NO

- YES >> Repair or replace harness as necessary.
 NO >> Inspection End.

A
B
C
D
E
F
G
H
I
K
L
M

MTC

TROUBLE DIAGNOSIS

10. CHECK FRONT BLOWER MOTOR POWER SUPPLY CIRCUIT FOR SHORT

1. Turn ignition switch OFF.
2. Disconnect front blower motor connector.
3. Check continuity between front blower motor harness connector M62 terminal 2 and ground.

2 - Ground : Continuity should not exist.

OK or NG

- OK >> GO TO 11.
NG >> Repair or replace harness as necessary.

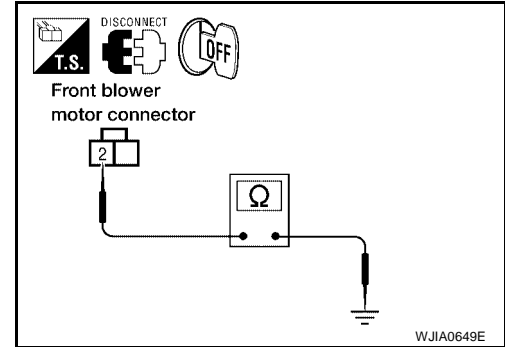

11. CHECK FRONT BLOWER MOTOR RELAY (SWITCH SIDE) POWER SUPPLY CIRCUIT FOR SHORT

1. Disconnect front blower motor relay connector.
2. Check continuity between the front blower motor relay harness connector E54 terminal 7 and terminal 5 and ground.

7, 5 - Ground : Continuity should not exist.

OK or NG

- OK >> Check front blower motor. Refer to [MTC-64, "Front Blower Motor"](#) .
NG >> Repair harness or connector.

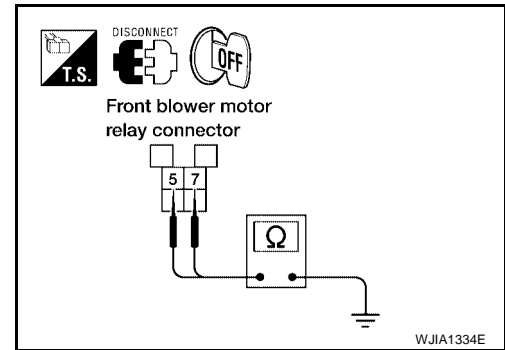

12. CHECK FRONT BLOWER MOTOR

1. Turn ignition switch OFF.
2. Check front blower motor. Refer to [MTC-64, "Front Blower Motor"](#) .

OK or NG

- OK >> GO TO 13.
NG >> Replace front blower motor. Refer to [MTC-84, "BLOWER MOTOR"](#) .

13. CHECK FRONT BLOWER MOTOR RESISTOR

Check front blower motor resistor. Refer to [MTC-58, "Blower Motor Resistor"](#) .

OK or NG

- OK >> GO TO 14.
NG >> Replace front blower motor resistor. Refer to [MTC-93, "Removal and Installation"](#) .

14. CHECK FRONT BLOWER SWITCH

Check front blower switch. Refer to [MTC-64, "Front Blower Switch"](#) .

OK or NG

- OK >> GO TO 15.
NG >> Replace front blower switch. Refer to [MTC-82, "FRONT AIR CONTROL"](#) .

TROUBLE DIAGNOSIS

15. CHECK FRONT BLOWER MOTOR GROUND CIRCUIT TO FRONT BLOWER MOTOR RESISTOR

1. Disconnect front blower motor resistor harness connector.
2. Check continuity between front blower motor connector M62 (A) terminal 1 and front blower motor resistor harness connector M122 (B) terminal 3.

A		B		Continuity
Connector	Terminal	Connector	Terminal	
Front blower motor: M62	1	Front blower motor resistor: M122	3	Yes

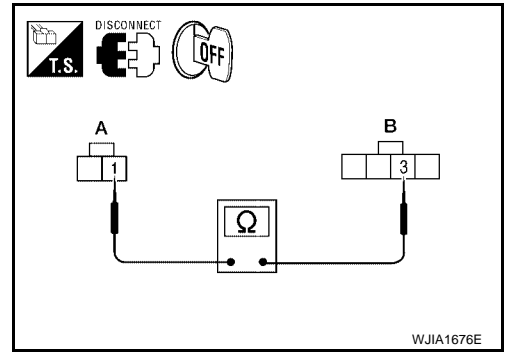

OK or NG

- OK >> Repair harness or connector between front blower switch connector M51 terminal 8 and ground.
- NG >> Repair harness or connector between front blower motor resistor and front blower motor.

16. CHECK FRONT BLOWER SWITCH

Check front blower switch. Refer to [MTC-64, "Front Blower Switch"](#).

OK or NG

- OK >> Repair harness or connector between front blower motor switch connector M51 terminal 8 and front blower motor resistor connector M122 terminal 3.
- NG >> Replace front blower switch. Refer to [MTC-82, "FRONT AIR CONTROL"](#).

COMPONENT INSPECTION

Front Blower Motor Relay

Check continuity between terminals by supplying 12 volts and ground to coil side terminals of relay.

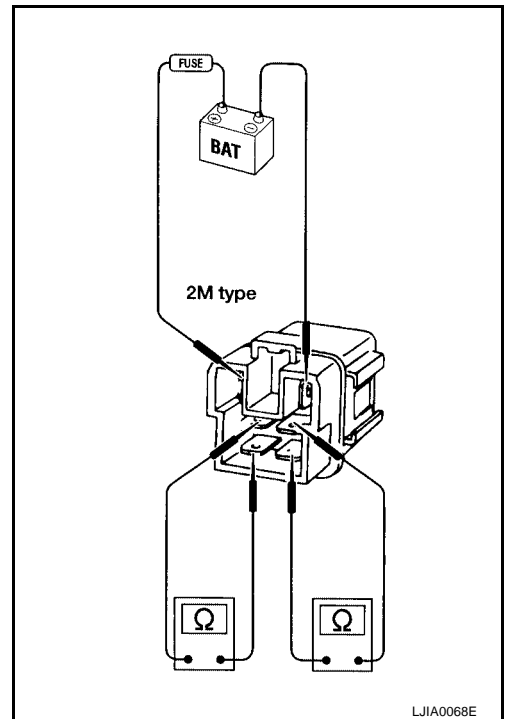

TROUBLE DIAGNOSIS

Front Blower Motor

Confirm smooth rotation of the blower motor.

- Ensure that there are no foreign particles inside the blower unit.
- Apply 12 volts to terminal 2 and ground to terminal 1 and verify that the motor operates freely and quietly.

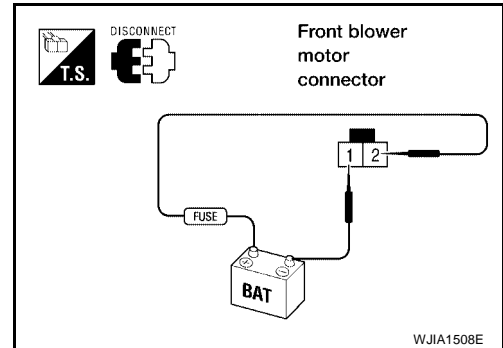

Front Blower Switch

Check continuity between terminals at each switch position.

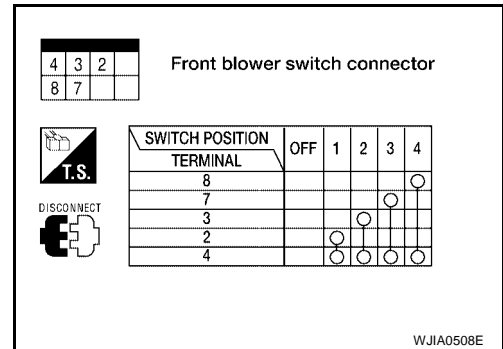

TROUBLE DIAGNOSIS

EJS004RR

Magnet Clutch Circuit

SYMPTOM: Magnet clutch does not engage.

INSPECTION FLOW

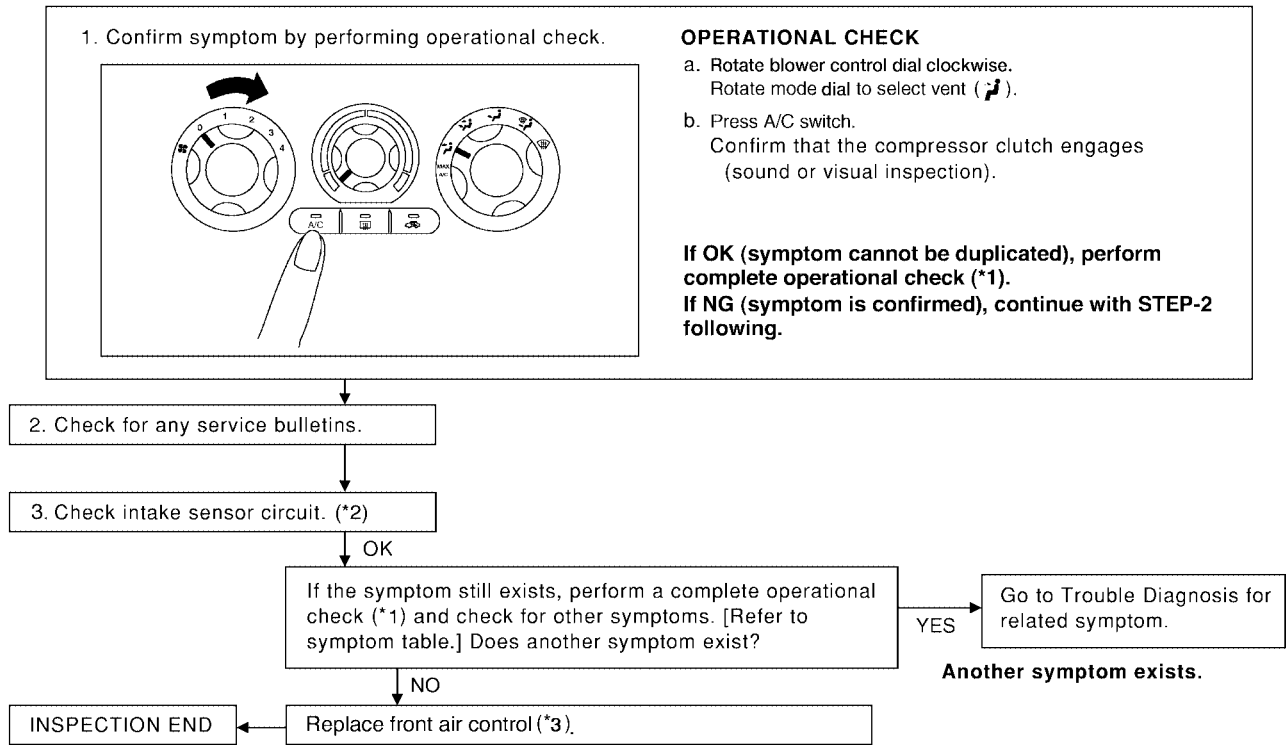

*1 [.ATC-53. "Operational Check \(Front\)"](#)

*2 [ATC-125. "Intake Sensor Circuit"](#)

*3 [MTC-82. "FRONT AIR CONTROL"](#)

WJIA1677E

TROUBLE DIAGNOSIS

SYSTEM DESCRIPTION

The front air control controls compressor operation based on ambient and intake temperature and a signal from ECM.

Low Temperature Protection Control

The front air control will turn the compressor ON or OFF as determined by a signal detected by the intake sensor and the ambient sensor.

When intake air temperature is higher than 3.5° C (38.3° F), the compressor turns ON. The compressor turns OFF when intake air temperature is lower than 2.5° C (36.5° F).

DIAGNOSTIC PROCEDURE FOR MAGNET CLUTCH

SYMPTOM: Magnet clutch does not engage when A/C switch is ON.

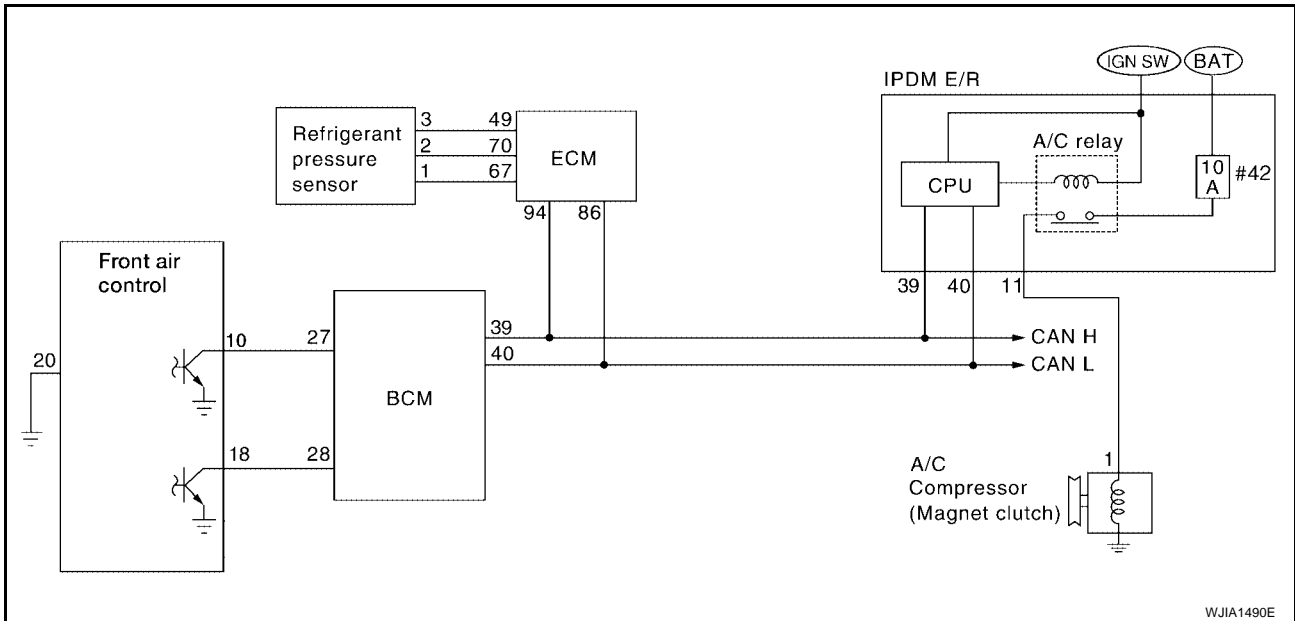

WJIA1490E

1. PERFORM AUTO ACTIVE TEST

Refer to [PG-24, "Auto Active Test"](#).

Does magnet clutch operate?

YES or NO

YES >> ● WITH CONSULT-II
GO TO 2.

● WITHOUT CONSULT-II
GO TO 8.

NO >> Check 10A fuse (No. 42, located in IPDM E/R), and GO TO 12.

2. CHECK BCM INPUT (A/C COMPRESSOR ON) SIGNAL

Check A/C compressor ON/OFF signal. Refer to [MTC-29, "CONSULT-II Function \(BCM\)"](#).

A/C SW ON : COMP ON SIG ON

A/C SW OFF : COMP ON SIG OFF

OK or NG

OK >> GO TO 3.

NG >> GO TO 8.

DATA MONITOR			
MONITOR			
FAN ON SIG	ON		
COMP ON SIG	ON		
IGN ON SW	ON		
RECORD			
MODE	BACK	LIGHT	COPY

WJIA0469E

TROUBLE DIAGNOSIS

3. CHECK REFRIGERANT PRESSURE SENSOR

Check refrigerant pressure sensor. Refer to [EC-659, "REFRIGERANT PRESSURE SENSOR"](#) .

OK or NG

OK >> GO TO 4.

NG >> Replace refrigerant pressure sensor. Refer to [EC-663, "Removal and Installation"](#) .

4. CHECK BCM INPUT (FAN ON) SIGNAL

Check FAN ON/OFF signal. Refer to [MTC-29, "CONSULT-II Function \(BCM\)"](#) .

**BLOWER CONTROL DIAL : FAN ON SIG ON
ON**

**BLOWER CONTROL DIAL : FAN ON SIG OFF
OFF**

OK or NG

OK >> GO TO 7.

NG >> GO TO 5.

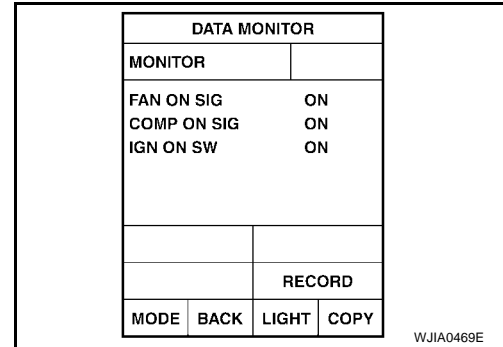

5. CHECK CIRCUIT CONTINUITY BETWEEN BCM AND FRONT AIR CONTROL

1. Turn ignition switch OFF.
2. Disconnect BCM connector and front air control connector.
3. Check continuity between BCM harness connector M18 (A) terminal 28 and front air control harness connector M49 (B) terminal 18.

A		B		
Connector	Terminal	Connector	Terminal	Continuity
BCM: M18	28	Front air control: M49	18	Yes

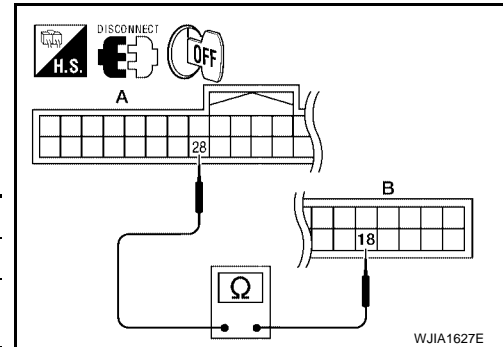

OK or NG

OK >> GO TO 6.

NG >> Repair harness or connector.

A
B
C
D
E
F
G
H
I
K
L
M

MTC

TROUBLE DIAGNOSIS

6. CHECK VOLTAGE FOR FRONT AIR CONTROL (FAN ON SIGNAL)

1. Reconnect BCM connector and front air control connector.
2. Turn ignition switch ON.
3. Turn A/C switch ON.
4. Check voltage between front air control harness connector M49 terminal 18 and ground.

Terminals		(-)	Condition	Voltage (Approx.)
(+)	Terminal No.			
Front air control connector				
M49	18	Ground	A/C switch: ON Blower motor operates	0V
			A/C switch: OFF	5V

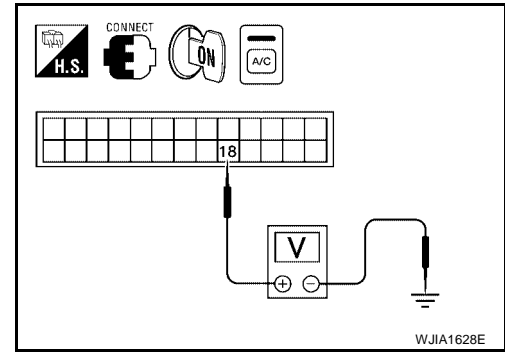

OK or NG

- OK >> Replace BCM. Refer to [BCS-27, "Removal and Installation"](#) .
- NG-1 >> If the voltage is approx. 5V when blower motor is ON, replace front air control. Refer to [MTC-82, "CONTROL UNIT"](#) .
- NG-2 >> If the voltage is approx. 0V when blower motor is OFF, replace BCM. Refer to [BCS-27, "Removal and Installation"](#) .

7. CHECK CAN COMMUNICATION

Check CAN communication. Refer to [LAN-25, "CAN COMMUNICATION"](#) .

OK or NG

- OK >> Inspection End.
- NG >> Repair or replace malfunctioning part(s).

8. CHECK VOLTAGE FOR FRONT AIR CONTROL (A/C COMPRESSOR ON SIGNAL)

1. Reconnect BCM connector and front air control connector.
2. Turn ignition switch ON.
3. Check voltage between front air control harness connector M49 terminal 10 and ground.

Terminals		(-)	Condition	Voltage (Approx.)
(+)	Terminal No.			
Front air control connector				
M49	10	Ground	A/C switch: ON	0V
			A/C switch: OFF	Battery voltage

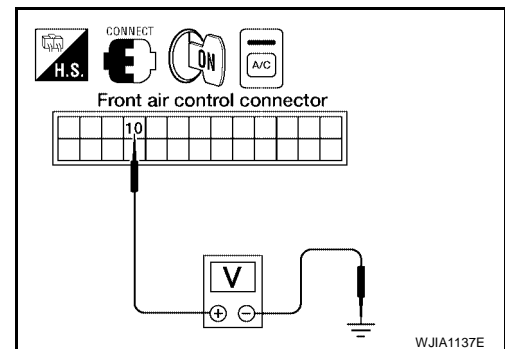

OK or NG

- OK >> GO TO 9.
- NG-1 >> If the voltage is approx. 5V when A/C switch is ON, replace front air control. Refer to [MTC-82, "CONTROL UNIT"](#) .
- NG-2 >> If the voltage is approx. 0V when A/C switch is OFF, replace BCM. Refer to [BCS-27, "Removal and Installation"](#) .

TROUBLE DIAGNOSIS

9. CHECK CIRCUIT CONTINUITY BETWEEN BCM AND FRONT AIR CONTROL

1. Disconnect BCM connector and front air control connector.
2. Check continuity between BCM harness connector M18 terminal 27 and front air control harness connector M49 terminal 10.

27 - 10 : Continuity should exist.

OK or NG

- OK >> GO TO 10.
NG >> Repair harness or connector.

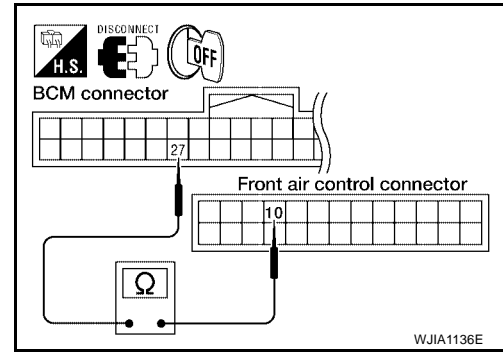

10. CHECK INTAKE SENSOR CIRCUITS

Check intake sensor. Refer to [MTC-80, "Intake Sensor Circuit"](#).

OK or NG

- OK >> GO TO 11.
NG >> Replace intake sensor. Refer to [MTC-83, "INTAKE SENSOR"](#).

11. CHECK CAN COMMUNICATION

Check CAN communication. Refer to [LAN-25, "CAN COMMUNICATION"](#).

OK or NG

- OK >> Replace BCM. Refer to [BCS-27, "Removal and Installation"](#).
NG >> Repair or replace malfunctioning part(s).

12. CHECK MAGNET CLUTCH CIRCUIT

Check for operation sound when applying battery voltage to terminal.

OK or NG

- OK >> GO TO 13.
NG >> Replace magnet clutch. Refer to [MTC-102, "Removal and Installation for Compressor Clutch"](#).

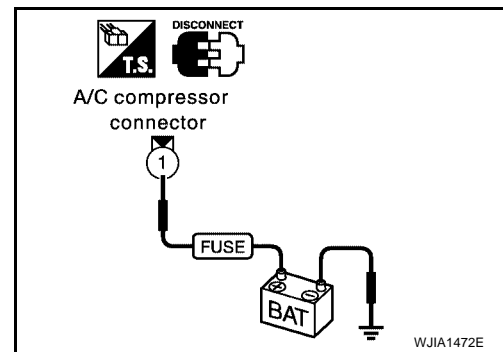

13. CHECK CIRCUIT CONTINUITY BETWEEN IPDM E/R AND A/C COMPRESSOR

1. Turn ignition switch OFF.
2. Disconnect IPDM E/R connector and A/C compressor (magnet clutch) connector.
3. Check continuity between IPDM E/R harness connector E119 terminal 11 and A/C compressor harness connector F3 terminal 1.

11 - 1 : Continuity should exist.

OK or NG

- OK >> Replace IPDM E/R. Refer to [PG-32, "Removal and Installation of IPDM E/R"](#).
NG >> Repair harness or connector.

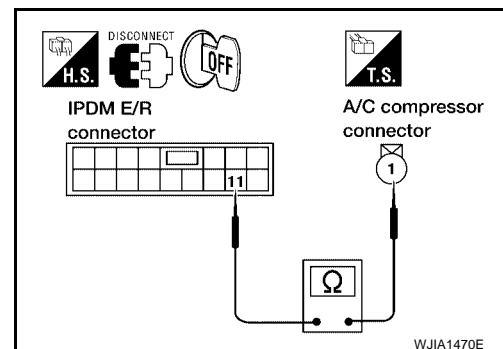

TROUBLE DIAGNOSIS

EJS004RS

Insufficient Cooling

SYMPTOM: Insufficient cooling

INSPECTION FLOW

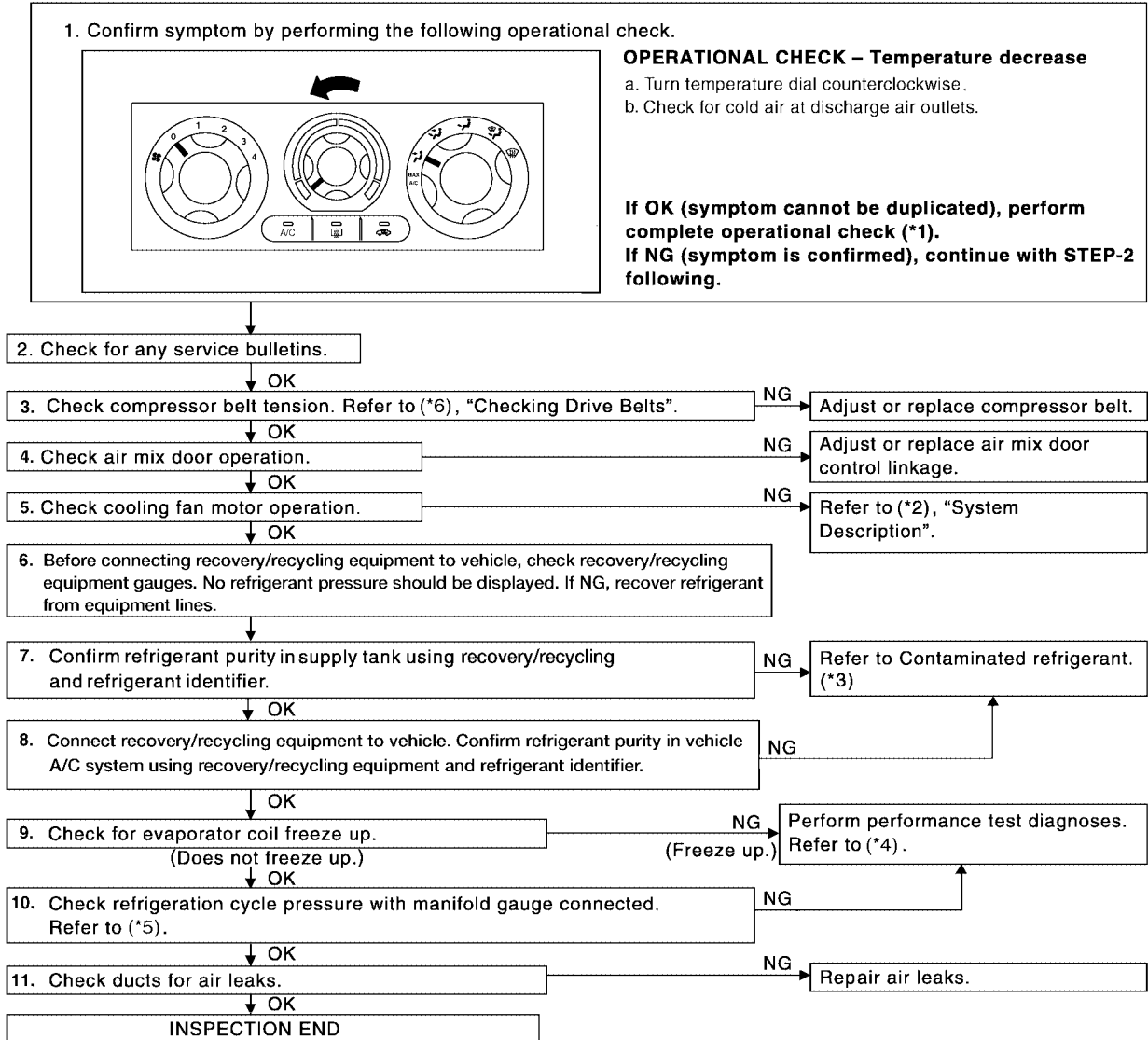

WJIA1340E

*1 [ATC-53, "Operational Check \(Front\)"](#)

*2 [EC-493, "SYSTEM DESCRIPTION"](#)

*3 [ATC-5, "Contaminated Refrigerant"](#)

*4 [ATC-103, "PERFORMANCE TEST DIAGNOSES"](#)

*5 [ATC-105, "Test Reading"](#)

*6 [MA-13, "Checking Drive Belts"](#)

TROUBLE DIAGNOSIS

PERFORMANCE TEST DIAGNOSES

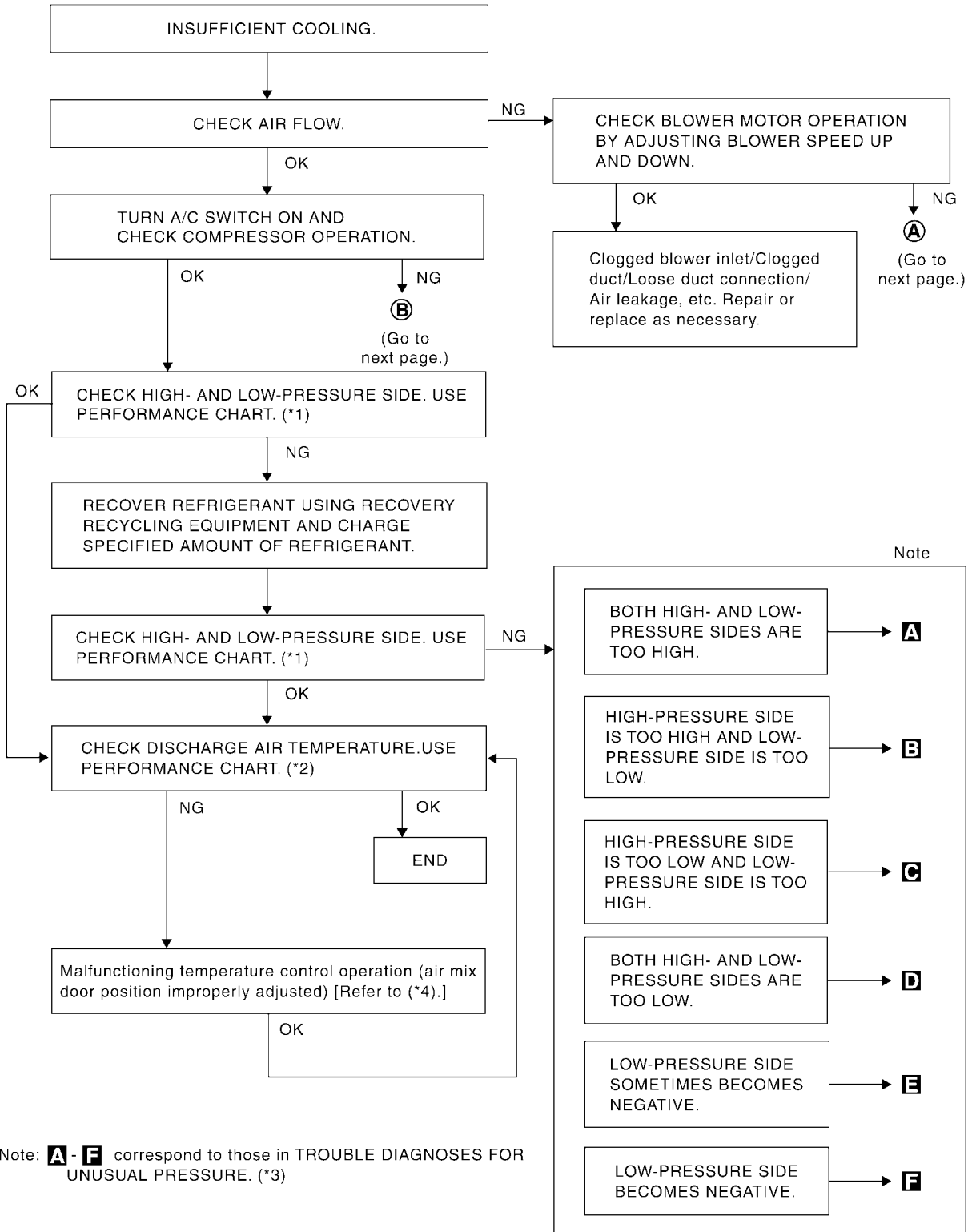

Note: **A - F** correspond to those in TROUBLE DIAGNOSES FOR UNUSUAL PRESSURE. (*3)

*1 [ATC-105. "PERFORMANCE CHART"](#)

*2 [ATC-105. "PERFORMANCE CHART"](#)

*3 [ATC-106. "Trouble Diagnoses for Unusual Pressure"](#)

*4 [ATC-63. "Air Mix Door Motor Circuit"](#)

RJIA1601E

TROUBLE DIAGNOSIS

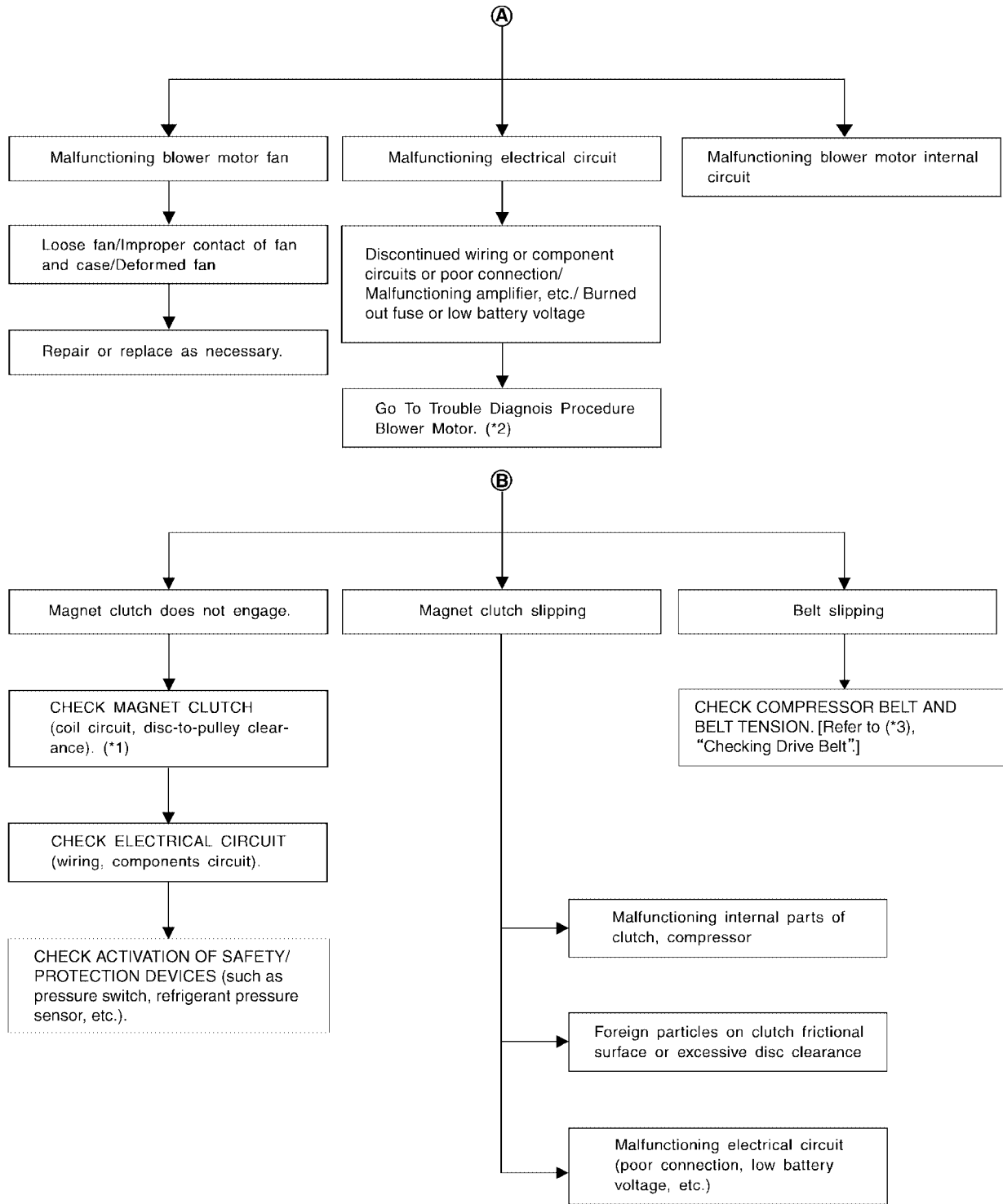

RJIA3107E

*1 [ATC-159. "Removal and Installation for Compressor Clutch"](#)

*2 [ATC-75. "Front Blower Motor Circuit"](#)



*3 [MA-13. "Checking Drive Belts"](#)

TROUBLE DIAGNOSIS

PERFORMANCE CHART

Test Condition

Testing must be performed as follows:

Vehicle location	Indoors or in the shade (in a well-ventilated place)
Doors	Closed
Door window	Open
Hood	Open
TEMP.	Max. COLD
Mode switch	 (Ventilation) set
Recirculation (REC) switch	 (Recirculation) set
 Blower speed	Max. speed set
Engine speed	Idle speed

Operate the air conditioning system for 10 minutes before taking measurements.

Test Reading

Recirculating-to-discharge Air Temperature Table

Inside air (Recirculating air) at blower assembly inlet		Discharge air temperature at center ventilator °C (°F)
Relative humidity %	Air temperature °C (°F)	
50 - 60	20 (68)	5.3 - 6.5 (42 - 44)
	25 (77)	9.7 - 11.5 (49 - 53)
	30 (86)	13.8 - 16.3 (57 - 61)
	35 (95)	18.0 - 21.2 (64 - 70)
	40 (104)	22.2 - 25.7 (72 - 78)
60 - 70	20 (68)	6.5 - 7.7 (44 - 46)
	25 (77)	11.5 - 13.3 (53 - 56)
	30 (86)	16.3 - 18.8 (61 - 66)
	35 (95)	21.2 - 24.0 (70 - 75)
	40 (104)	25.7 - 29.2 (78 - 85)

Ambient Air Temperature-to-operating Pressure Table

Ambient air		High-pressure (Discharge side) kPa (kg/cm ² , psi)	Low-pressure (Suction side) kPa (kg/cm ² , psi)
Relative humidity %	Air temperature °C (°F)		
50 - 70	20 (68)	680 - 840 (6.94 - 8.57, 98.6 - 121.8)	160 - 198 (1.63 - 2.02, 23.2 - 28.7)
	25 (77)	800 - 985 (8.16 - 10.05, 116.0 - 142.8)	198 - 245 (2.02 - 2.50, 28.7 - 35.5)
	30 (86)	940 - 1,150 (9.59 - 11.73, 136.3 - 166.8)	225 - 278 (2.30 - 2.84, 32.6 - 40.3)
	35 (95)	1,160 - 1,410 (11.83 - 14.38, 168.2 - 204.5)	273 - 335 (2.78 - 3.42, 39.6 - 48.6)
	40 (104)	1,325 - 1,620 (13.52 - 16.52, 192.1 - 234.9)	325 - 398 (3.32 - 4.06, 47.1 - 57.7)

TROUBLE DIAGNOSIS

TROUBLE DIAGNOSES FOR UNUSUAL PRESSURE

Whenever system's high and/or low side pressure is unusual, diagnose using a manifold gauge. The marker above the gauge scale in the following tables indicates the standard (usual) pressure range. Since the standard (usual) pressure, however, differs from vehicle to vehicle, refer to above table (Ambient air temperature-to-operating pressure table).

Both High- and Low-pressure Sides are Too High

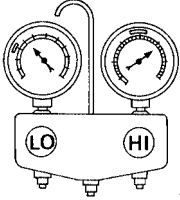
Gauge indication	Refrigerant cycle	Probable cause	Corrective action
<p>Both high- and low-pressure sides are too high.</p>  <p style="text-align: right; font-size: small;">AC359A</p>	Pressure is reduced soon after water is splashed on condenser.	Excessive refrigerant charge in refrigeration cycle	Reduce refrigerant until specified pressure is obtained.
	Air suction by cooling fan is insufficient.	Insufficient condenser cooling performance ↓ 1. Condenser fins are clogged. 2. Improper fan rotation of cooling fan	<ul style="list-style-type: none"> ● Clean condenser. ● Check and repair cooling fan if necessary.
	<ul style="list-style-type: none"> ● Low-pressure pipe is not cold. ● When compressor is stopped high-pressure value quickly drops by approximately 196 kPa (2 kg/cm², 28 psi). It then decreases gradually thereafter. 	Poor heat exchange in condenser (After compressor operation stops, high-pressure decreases too slowly.) ↓ Air in refrigeration cycle	Evacuate and recharge system.
	Engine tends to overheat.	Engine cooling systems malfunction.	Check and repair engine cooling system.
	<ul style="list-style-type: none"> ● An area of the low-pressure pipe is colder than areas near the evaporator outlet. ● Plates are sometimes covered with frost. 	<ul style="list-style-type: none"> ● Excessive liquid refrigerant on low-pressure side ● Excessive refrigerant discharge flow ● Expansion valve is open a little compared with the specification. ↓ Improper expansion valve adjustment	Replace expansion valve.

High-pressure Side is Too High and Low-pressure Side is Too Low

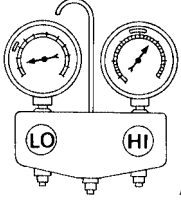
Gauge indication	Refrigerant cycle	Probable cause	Corrective action
<p>High-pressure side is too high and low-pressure side is too low.</p>  <p style="text-align: right; font-size: small;">AC360A</p>	Upper side of condenser and high-pressure side are hot, however, liquid tank is not so hot.	High-pressure tube or parts located between compressor and condenser are clogged or crushed.	<ul style="list-style-type: none"> ● Check and repair or replace malfunctioning parts. ● Check oil for contamination.

TROUBLE DIAGNOSIS

High-pressure Side is Too Low and Low-pressure Side is Too High

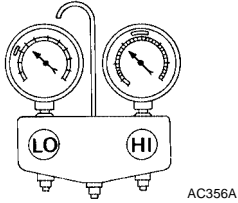
Gauge indication	Refrigerant cycle	Probable cause	Corrective action
High-pressure side is too low and low-pressure side is too high. 	High- and low-pressure sides become equal soon after compressor operation stops.	Compressor pressure operation is improper. ↓ Damaged inside compressor packings.	Replace compressor.
	No temperature difference between high- and low-pressure sides.	Compressor pressure operation is improper. ↓ Damaged inside compressor packings.	Replace compressor.

Both High- and Low-pressure Sides are Too Low

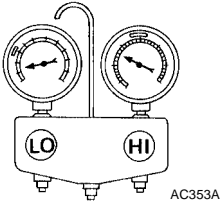
Gauge indication	Refrigerant cycle	Probable cause	Corrective action
Both high- and low-pressure sides are too low. 	<ul style="list-style-type: none"> There is a big temperature difference between liquid tank outlet and inlet. Outlet temperature is extremely low. Liquid tank inlet and expansion valve are frosted. 	Liquid tank inside is slightly clogged.	<ul style="list-style-type: none"> Replace liquid tank. Check oil for contamination.
	<ul style="list-style-type: none"> Temperature of expansion valve inlet is extremely low as compared with areas near liquid tank. Expansion valve inlet may be frosted. Temperature difference occurs somewhere in high-pressure side. 	High-pressure pipe located between liquid tank and expansion valve is clogged.	<ul style="list-style-type: none"> Check and repair malfunctioning parts. Check oil for contamination.
	Expansion valve and liquid tank are warm or only cool when touched.	Low refrigerant charge. ↓ Leaking fittings or components.	Check refrigerant system for leaks. Refer to ATC-170, "Checking for Refrigerant Leaks" .
	There is a big temperature difference between expansion valve inlet and outlet while the valve itself is frosted.	Expansion valve closes a little compared with the specification. ↓ <ol style="list-style-type: none"> Improper expansion valve adjustment. Malfunctioning expansion valve. Outlet and inlet may be clogged. 	<ul style="list-style-type: none"> Remove foreign particles by using compressed air. Check oil for contamination.
	An area of the low-pressure pipe is colder than areas near the evaporator outlet.	Low-pressure pipe is clogged or crushed.	<ul style="list-style-type: none"> Check and repair malfunctioning parts. Check oil for contamination.
	Air flow volume is too low.	Evaporator is frozen.	<ul style="list-style-type: none"> Check intake sensor circuit. Refer to ATC-125, "Intake Sensor Circuit". Replace compressor. Repair evaporator fins. Replace evaporator. Refer to ATC-75, "Front Blower Motor Circuit".

TROUBLE DIAGNOSIS

Low-pressure Side Sometimes Becomes Negative

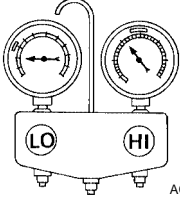
Gauge indication	Refrigerant cycle	Probable cause	Corrective action
<p>Low-pressure side sometimes becomes negative.</p>  <p style="text-align: right; font-size: small;">AC354A</p>	<ul style="list-style-type: none"> ● Air conditioning system does not function and does not cyclically cool the compartment air. ● The system constantly functions for a certain period of time after compressor is stopped and restarted. 	<p>Refrigerant does not discharge cyclically.</p> <p>↓</p> <p>Moisture is frozen at expansion valve outlet and inlet.</p> <p>↓</p> <p>Water is mixed with refrigerant.</p>	<ul style="list-style-type: none"> ● Drain water from refrigerant or replace refrigerant. ● Replace liquid tank.

Low-pressure Side Becomes Negative

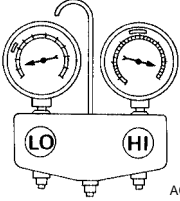
Gauge indication	Refrigerant cycle	Probable cause	Corrective action
<p>Low-pressure side becomes negative.</p>  <p style="text-align: right; font-size: small;">AC362A</p>	<p>Liquid tank or front/rear side of expansion valve's pipe is frosted or dewed.</p>	<p>High-pressure side is closed and refrigerant does not flow.</p> <p>↓</p> <p>Expansion valve or liquid tank is frosted.</p>	<p>Leave the system at rest until no frost is present. Start it again to check whether or not the malfunction is caused by water or foreign particles.</p> <ul style="list-style-type: none"> ● If water is the cause, initially cooling is okay. Then the water freezes causing a blockage. Drain water from refrigerant or replace refrigerant. ● If due to foreign particles, remove expansion valve and remove the particles with dry and compressed air (not shop air). ● If either of the above methods cannot correct the malfunction, replace expansion valve. ● Replace liquid tank. ● Check oil for contamination.

TROUBLE DIAGNOSIS

EJS004RT

Insufficient Heating

SYMPTOM: Insufficient heating

INSPECTION FLOW

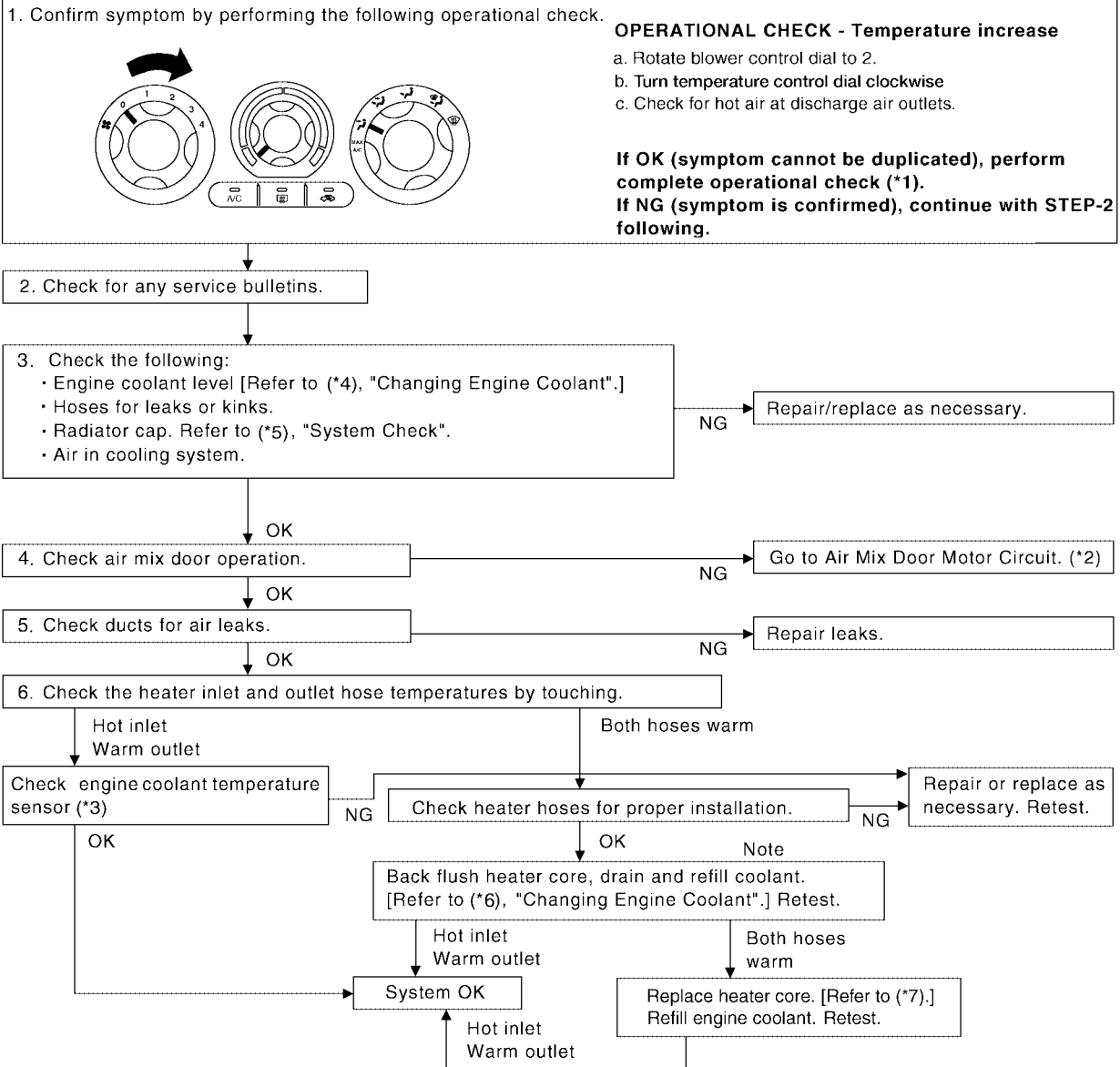

- *1 [ATC-53, "Operational Check \(Front\)"](#) *2 [ATC-63, "Air Mix Door Motor Circuit"](#) *3 [EC-207, "DTC P0117, P0118 ECT SENSOR"](#)
- *4 [MA-13, "Changing Engine Coolant"](#) *5 [CO-10, "CHECKING RESERVOIR CAP"](#) *6 [CO-10, "Changing Engine Coolant"](#)
- *7 [MTC-89, "HEATER CORE"](#)

WJIA1983E

TROUBLE DIAGNOSIS

EJS004RU

Noise

SYMPTOM: Noise

INSPECTION FLOW

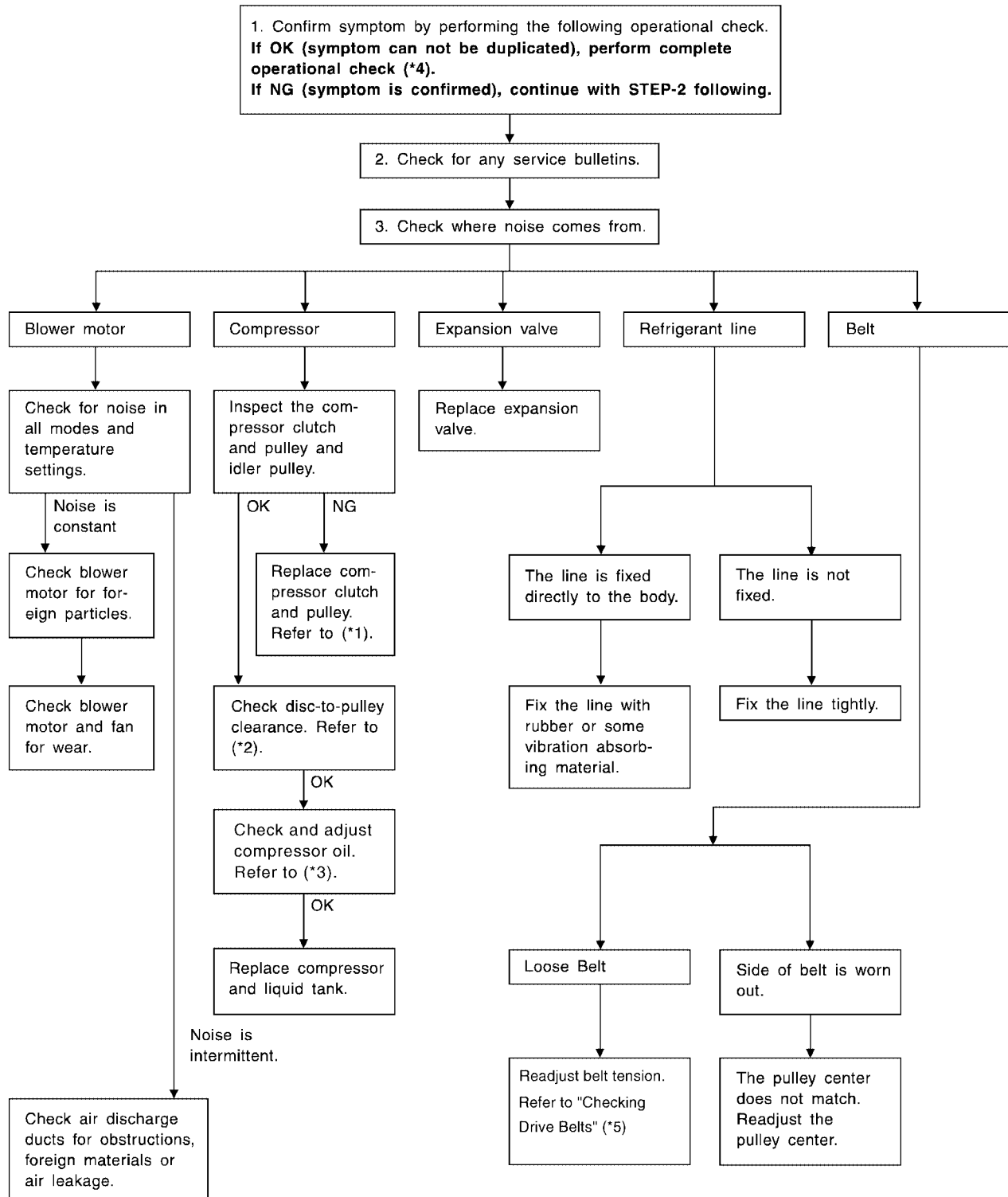

WJIA1972E

TROUBLE DIAGNOSIS

*1 [ATC-159, "REMOVAL"](#)

*2 [ATC-160, "INSTALLATION"](#)

*3 [ATC-22, "Maintenance of Oil Quantity in Compressor"](#)

*4 [ATC-53, "Operational Check \(Front\)"](#)

*5 [MA-13, "Checking Drive Belts"](#)

A

B

C

D

E

F

G

H

I

MTC

K

L

M

TROUBLE DIAGNOSIS

EJS004RV

Intake Sensor Circuit COMPONENT DESCRIPTION

Intake Sensor

The intake sensor is located on top of the heater and cooling unit assembly next to the A/C evaporator cover. It converts temperature of air after it passes through the evaporator into a resistance value which is then input to the front air control.

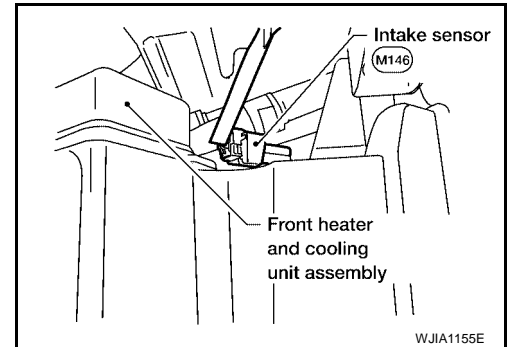

DIAGNOSTIC PROCEDURE FOR INTAKE SENSOR

SYMPTOM: Intake sensor circuit is open or shorted.

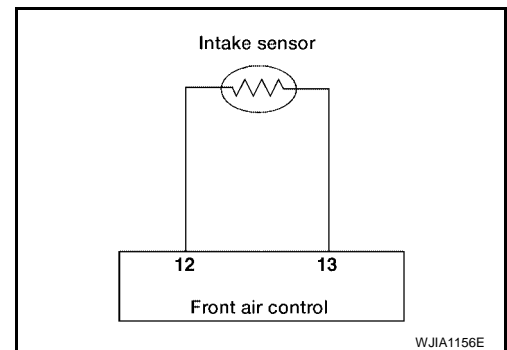

1. CHECK VOLTAGE BETWEEN INTAKE SENSOR AND GROUND

1. Disconnect intake sensor connector.
2. Turn ignition switch ON.
3. Check voltage between intake sensor harness connector M146 terminal 2 and ground.

2 - Ground : Approx. 5V

OK or NG

- OK >> GO TO 2.
NG >> GO TO 4.

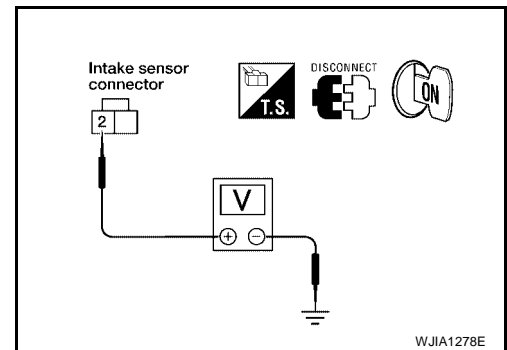

2. CHECK CIRCUIT CONTINUITY BETWEEN INTAKE SENSOR AND FRONT AIR CONTROL

1. Turn ignition switch OFF.
2. Disconnect front air control connector.
3. Check continuity between intake sensor harness connector M146 terminal 1 and front air control harness connector M49 terminal 13.

1 - 13 : Continuity should exist.

OK or NG

- OK >> GO TO 3.
NG >> Repair harness or connector.

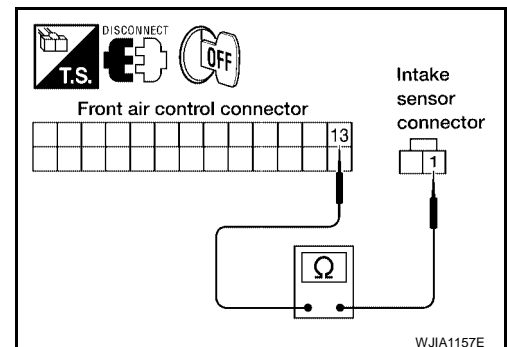

TROUBLE DIAGNOSIS

3. CHECK INTAKE SENSOR

Refer to [ATC-126, "Intake Sensor"](#) .

OK or NG

OK >> Replace front air control. Refer to [MTC-82, "FRONT AIR CONTROL"](#) .

NG >> Replace intake sensor. Refer to [MTC-83, "INTAKE SENSOR"](#) .

4. CHECK CIRCUIT CONTINUITY BETWEEN INTAKE SENSOR AND FRONT AIR CONTROL

1. Turn ignition switch OFF.
2. Disconnect front air control connector.
3. Check continuity between intake sensor harness connector M146 terminal 2 and front air control harness connector M49 terminal 12.

2 - 12 : Continuity should exist.

4. Check continuity between intake sensor harness connector M146 terminal 2 and ground.

2 - Ground : Continuity should not exist.

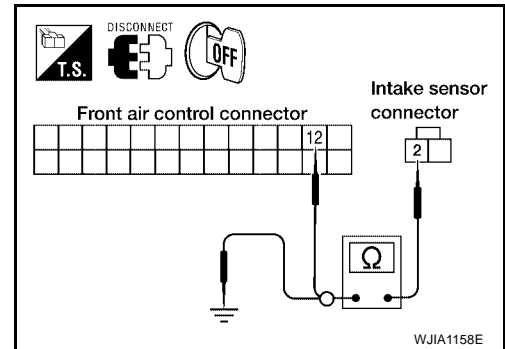

OK or NG

OK >> Replace front air control. Refer to [MTC-82, "FRONT AIR CONTROL"](#) .

NG >> Repair harness or connector.

COMPONENT INSPECTION

Intake Sensor

After disconnecting intake sensor connector, measure resistance between terminals 1 and 2 at sensor harness side, using the table below.

Temperature °C (°F)	Resistance kΩ
-15 (5)	209.0
-10 (14)	160.0
-5 (23)	123.0
0 (32)	95.8
5 (41)	74.9
10 (50)	58.9
15 (59)	46.7
20 (68)	37.3
25 (77)	30.0
30 (86)	24.2
35 (95)	19.7
40 (104)	16.1
45 (113)	13.2

If NG, replace intake sensor.

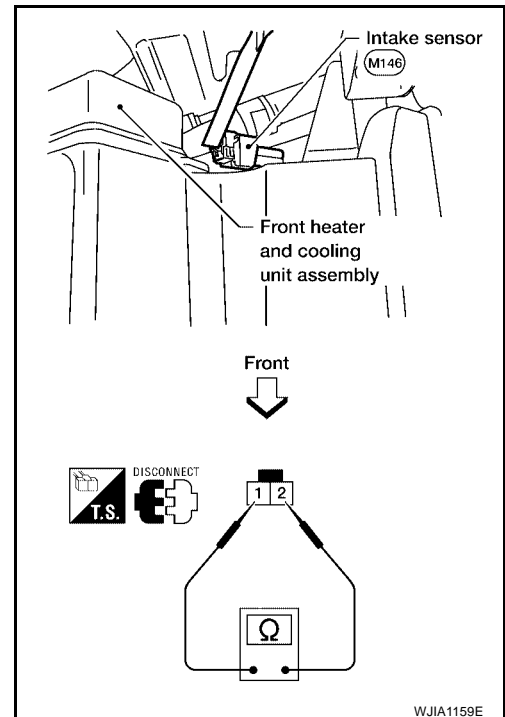

CONTROL UNIT

CONTROL UNIT

PFP:27500

Removal and Installation FRONT AIR CONTROL

EJS004RW

Removal

1. Remove cluster lid C. Refer to [JP-11, "CLUSTER LID C -WITH-OUT NAVIGATION SYSTEM"](#).
2. Remove the four screws securing the front air control to cluster lid C.
3. Remove the front air control.

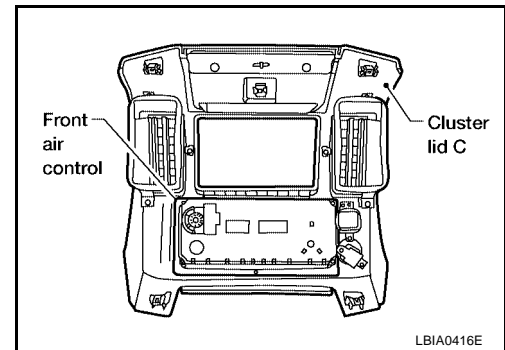

Installation

Installation is in the reverse order of removal.

INTAKE SENSOR

PF2:27723

EJS004RX

INTAKE SENSOR

Removal and Installation

REMOVAL

1. Remove the front kick plate. Refer to [EI-28, "KICK PLATES"](#) .
2. Remove the lower dash side finisher. Refer to [EI-28, "LOWER DASH SIDE FINISHER"](#) .
3. Remove the front pillar lower finisher. Refer to [EI-28, "FRONT PILLAR LOWER FINISHER"](#) .
4. Remove the assist grip handle
5. Remove the front pillar upper finisher. Refer to [EI-28, "FRONT PILLAR UPPER FINISHER"](#) .
6. Remove the lower glove box. Refer to [IP-15, "LOWER INSTRUMENT PANEL RH AND LOWER GLOVE BOX"](#) .
7. Remove the upper glove box (cluster lid E). Refer to [IP-10, "INSTRUMENT PANEL ASSEMBLY"](#) .
8. Disconnect the intake sensor electrical connector.

NOTE:

The intake sensor is located on the top of the heater and cooling unit assembly next to the A/C evaporator cover.

9. Twist the intake sensor to remove the intake sensor from the heater and cooling unit assembly.

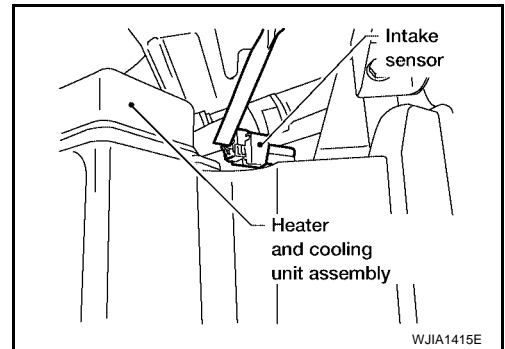

INSTALLATION

Installation is in the reverse order of removal.

A

B

C

D

E

F

G

H

I

MTC

K

L

M

BLOWER MOTOR

BLOWER MOTOR

PF2:27226

Components

EJS004RY

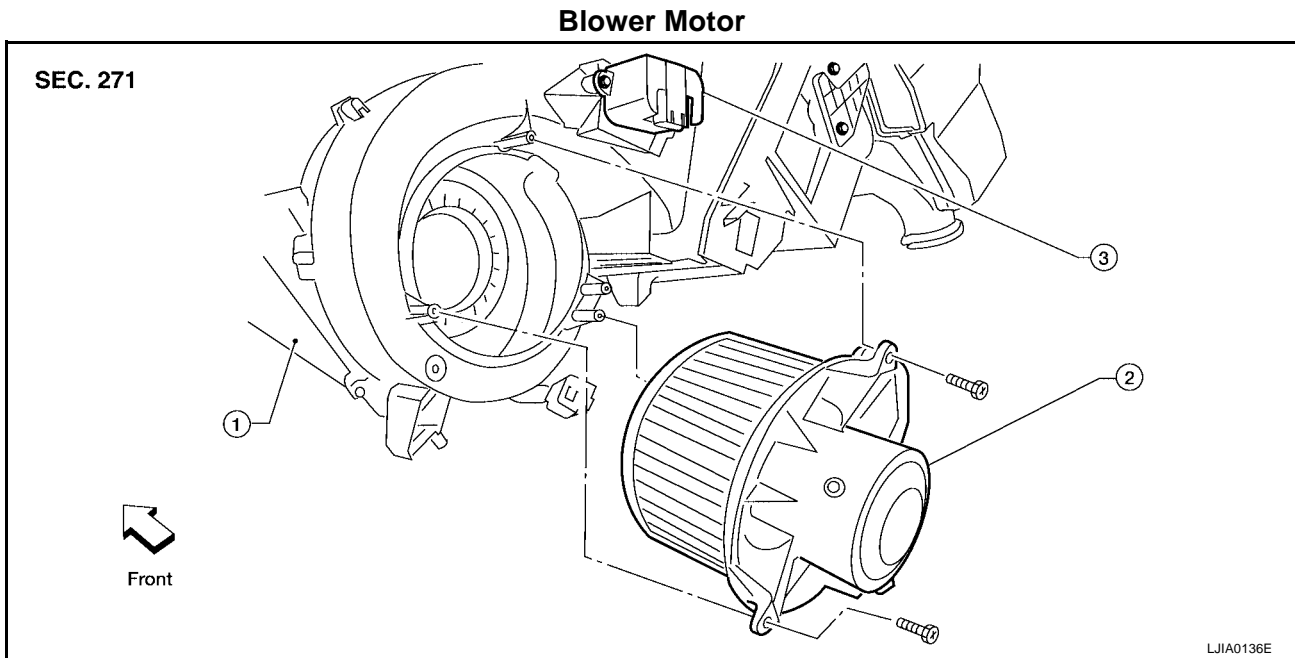

1. Heater and cooling unit assembly

2. Blower motor

3. Blower motor resistor

Removal and Installation

EJS004RZ

REMOVAL

1. Remove the lower glove box assembly. Refer to [IP-15, "LOWER INSTRUMENT PANEL RH AND LOWER GLOVE BOX"](#).
2. Disconnect the blower motor electrical connector.
3. Remove the three screws and remove the blower motor.

INSTALLATION

Installation is in the reverse order of removal.

IN-CABIN MICROFILTER

PFP:27277

EJS00450

IN-CABIN MICROFILTER

Removal and Installation FUNCTION

The air inside the passenger compartment is filtered by the in-cabin microfilters when the heater or A/C controls are set on either the recirculation or fresh mode. The two in-cabin microfilters are located in the heater and cooling unit assembly.

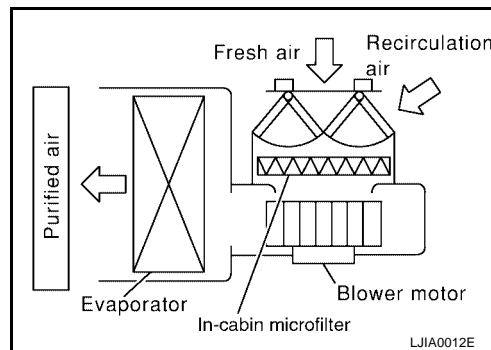

REPLACEMENT TIMING

Replacement of the two in-cabin microfilters is recommended on a regular interval depending on the driving conditions. Refer to [MA-7, "PERIODIC MAINTENANCE"](#). It may also be necessary to replace the two in-cabin microfilters as part of a component replacement if the in-cabin microfilters are damaged.

REPLACEMENT PROCEDURE

1. Open the lower glove box and press in on the sides so that it will open completely allowing it to hang by the cord.

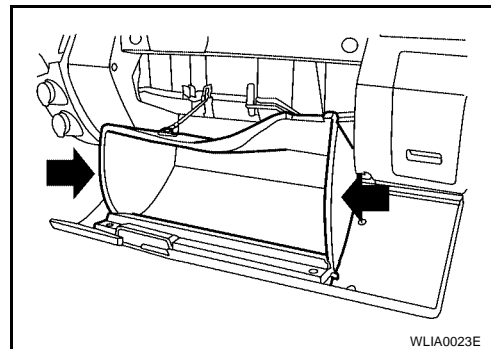

2. Remove the screw and remove the in-cabin microfilter cover.
3. Remove the in-cabin microfilters from the heater and cooling unit housing.

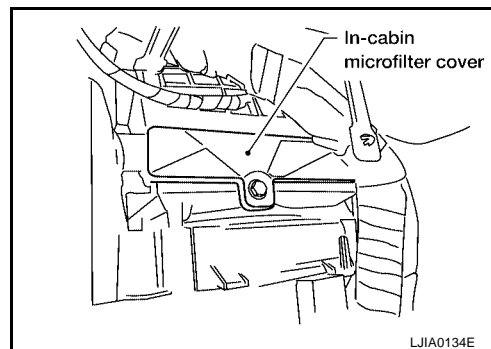

4. Insert the first new in-cabin microfilter into the heater and cooling unit housing and slide it over to the right. Insert the second new in-cabin microfilter into the heater and cooling unit housing.

NOTE:

The in-cabin microfilters are marked with air flow arrows. The end of the microfilter with the arrow should face the rear of the vehicle. The arrows should point downward.

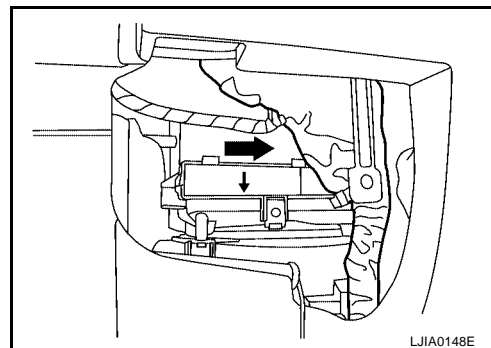

IN-CABIN MICROFILTER

5. Install the in-cabin microfilter cover.

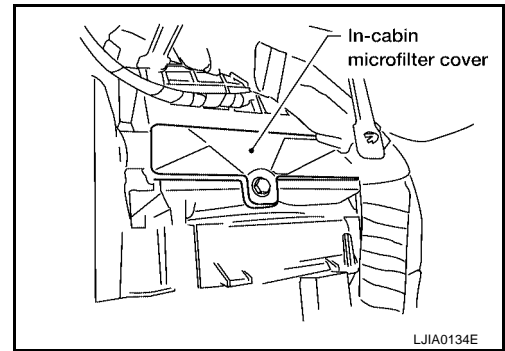

6. Close the lower glove box completely.

HEATER & COOLING UNIT ASSEMBLY

HEATER & COOLING UNIT ASSEMBLY

PF27110

Components

EJS004S1

Heater and Cooling Unit Assembly

SEC. 271 • 276 • 278

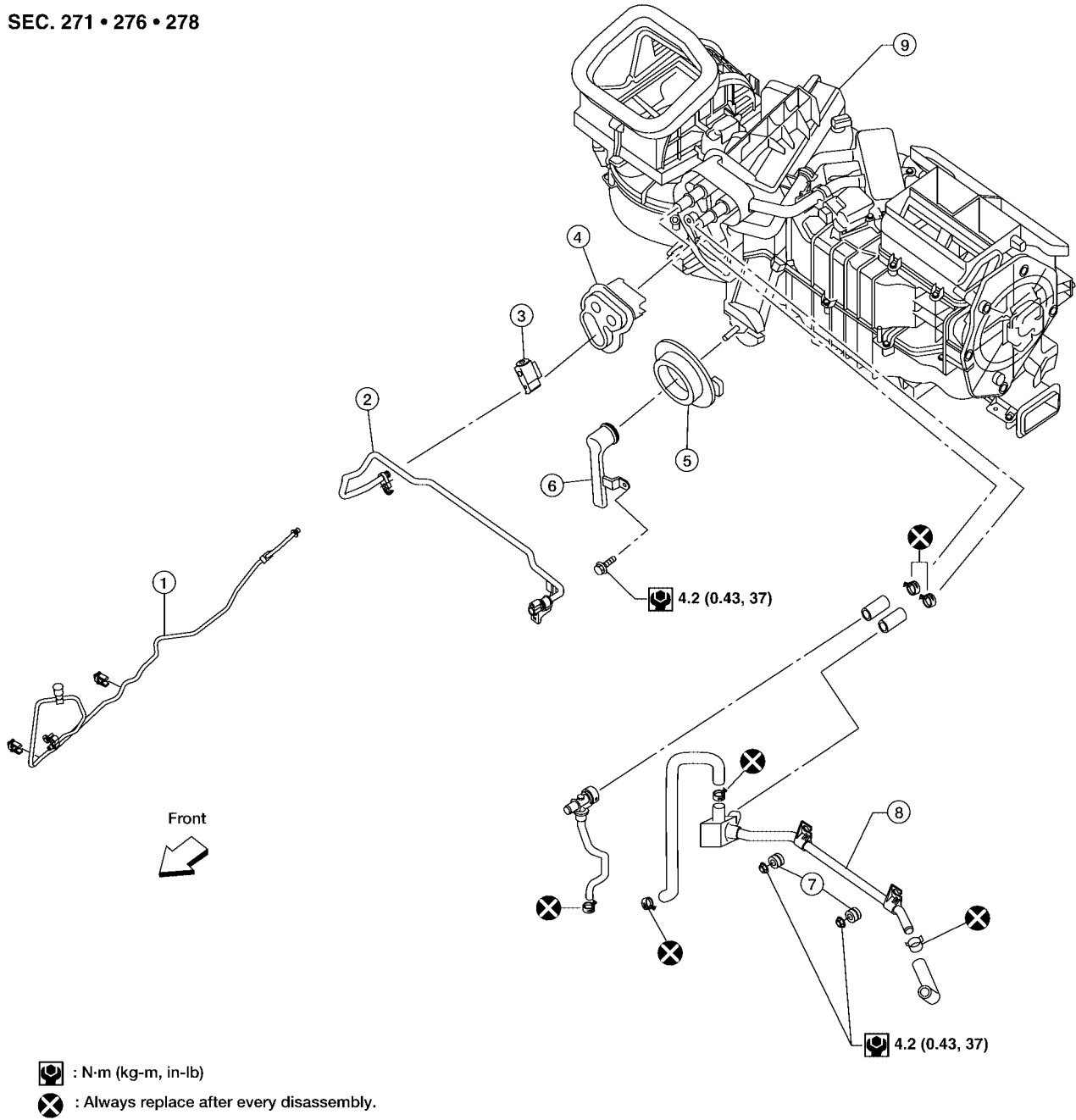

: N·m (kg·m, in·lb)

: Always replace after every disassembly.

- | | | |
|---|---------------------------|-------------------------------------|
| 1. High-pressure A/C pipe | 2. Low-pressure A/C pipe | 3. Expansion valve |
| 4. Heater core and evaporator pipes grommet | 5. A/C drain hose grommet | 6. A/C drain hose |
| 7. Heater core pipe mounts | 8. Heater core pipes | 9. Heater and cooling unit assembly |

WJIA1416E

Removal and Installation

REMOVAL

EJS004S2

1. Discharge the refrigerant from the A/C system. Refer to [ATC-154, "Discharging Refrigerant"](#).
2. Drain the coolant from the engine cooling system. Refer to [MA-13, "DRAINING ENGINE COOLANT"](#).
3. Disconnect the battery negative and positive terminals.

HEATER & COOLING UNIT ASSEMBLY

4. Remove the RH heater core pipes nut.
5. Disconnect the heater core hoses from the heater core.
6. Disconnect the high- and low-pressure A/C pipes from the expansion valve.
7. Move the two front seats to the rearmost position on the seat track.
8. Remove the instrument panel and console panel. Refer to [IP-10, "Removal and Installation"](#) .
9. Remove the two front floor ducts.
10. Remove the steering column. Refer to [PS-10, "Removal and Installation"](#) .
11. Disconnect the instrument panel wire harness at the RH and LH in-line connector brackets, and the fuse block (SMJ) electrical connectors. Refer to [PG-43, "Harness Layout"](#) .
12. Remove the covers then remove the three steering member bolts from each side to disconnect the steering member from the vehicle body.
13. Remove the heater and cooling unit assembly with it attached to the steering member, from the vehicle.
CAUTION:
 - Use care not to damage the seats and interior trim panels when removing the heater and cooling unit assembly with it attached to the steering member.
 - Use suitable plugs on the heater core pipes to prevent coolant leakage.
14. Remove the heater and cooling unit assembly from the steering member.

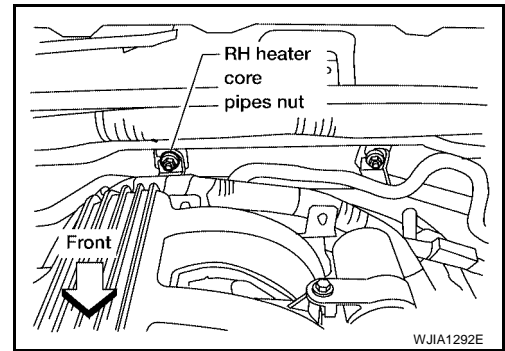

INSTALLATION

Installation is in the reverse order of removal.

CAUTION:

- Replace the O-ring of the low-pressure A/C pipe and high-pressure A/C pipe with a new one, and apply compressor oil to the O-ring for installation. Refer to [MTC-100, "Components"](#) .
- After charging the refrigerant, check for leaks. Refer to [ATC-170, "Checking for Refrigerant Leaks"](#) .

NOTE:

- Fill the engine cooling system with the specified coolant mixture. Refer to [MA-14, "REFILLING ENGINE COOLANT"](#) .
- Recharge the A/C system. Refer to [ATC-154, "Evacuating System and Charging Refrigerant"](#) .

HEATER CORE

HEATER CORE

PFP:27140

Components

EJS004S3

Heater and Cooling Unit Assembly

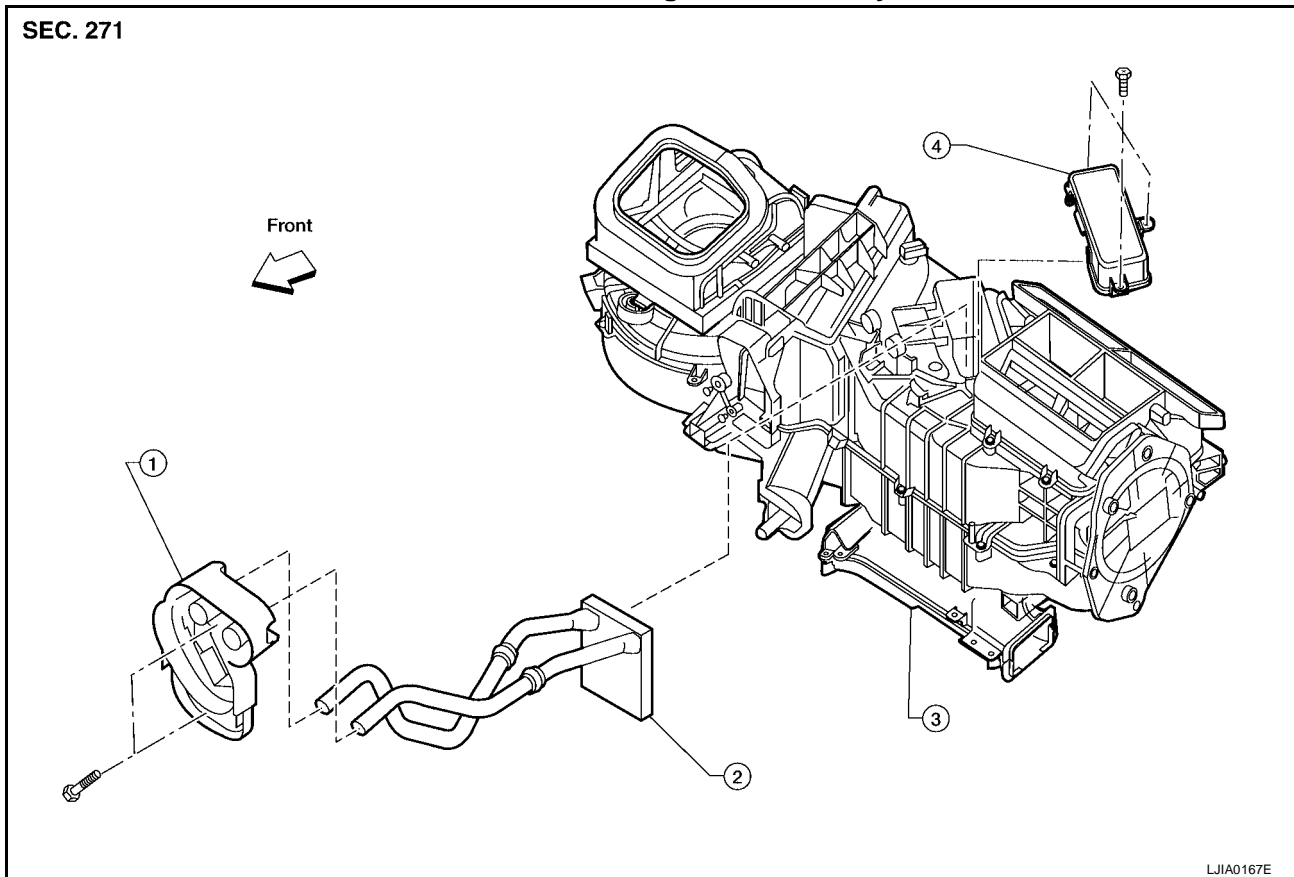

1. Heater core and evaporator pipe bracket
2. Heater core
3. Heater and cooling unit assembly
4. Heater core cover

Removal and Installation

EJS004S4

REMOVAL

1. Remove the heater and cooling unit assembly. Refer to [MTC-87, "HEATER & COOLING UNIT ASSEMBLY"](#).
2. Remove the three screws and remove the heater core cover.
3. Remove the heater core and evaporator pipe bracket.
4. Remove the heater core.

NOTE:

If the in-cabin microfilters are contaminated from coolant leaking from the heater core, replace the in-cabin microfilters with new ones before installing the new heater core.

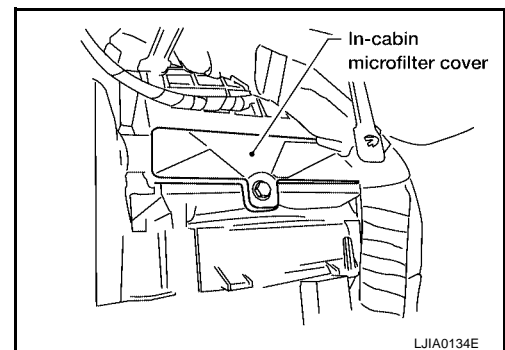

INSTALLATION

Installation is in the reverse order of removal.

INTAKE DOOR MOTOR

PF2:27730

EJS004S5

INTAKE DOOR MOTOR Removal and Installation

Intake Door Motor - Heater and Cooling Unit Assembly

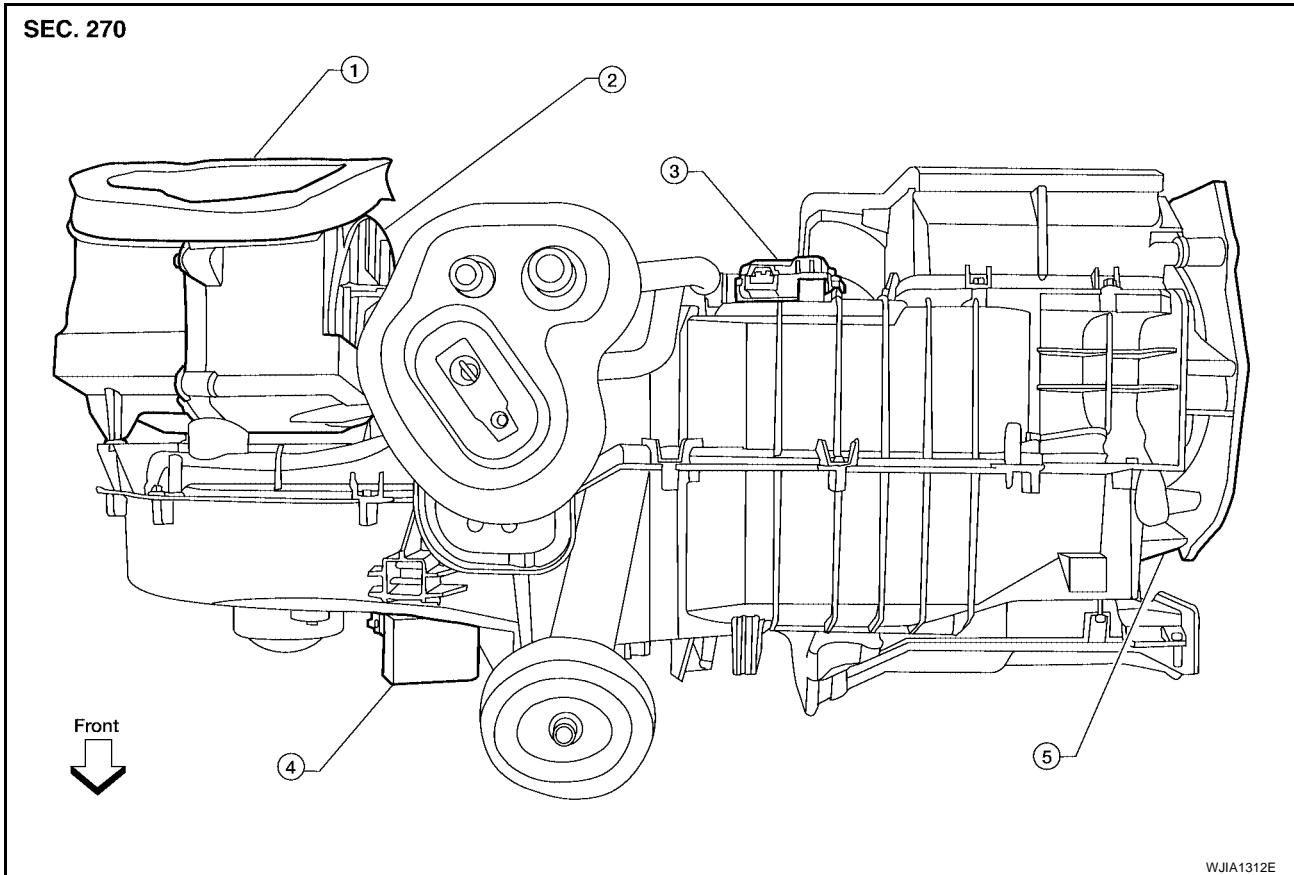

- | | | |
|-------------------------------------|----------------------|-----------------------|
| 1. Heater and cooling unit assembly | 2. Intake door motor | 3. Air mix door motor |
| 4. Blower motor resistor | 5. Mode door motor | |

REMOVAL

1. Remove the heater and cooling unit assembly. Refer to [MTC-87, "HEATER & COOLING UNIT ASSEMBLY"](#).
2. Remove the steering member from the heater and cooling unit assembly.
3. Disconnect the intake door motor electrical connector.
4. Remove the three screws and remove the intake door motor.

INSTALLATION

Installation is in the reverse order of removal.

MODE DOOR MOTOR

PFP:27731

MODE DOOR MOTOR

Removal and Installation

EJS00456

Mode Door Motor - Heater and Cooling Unit Assembly

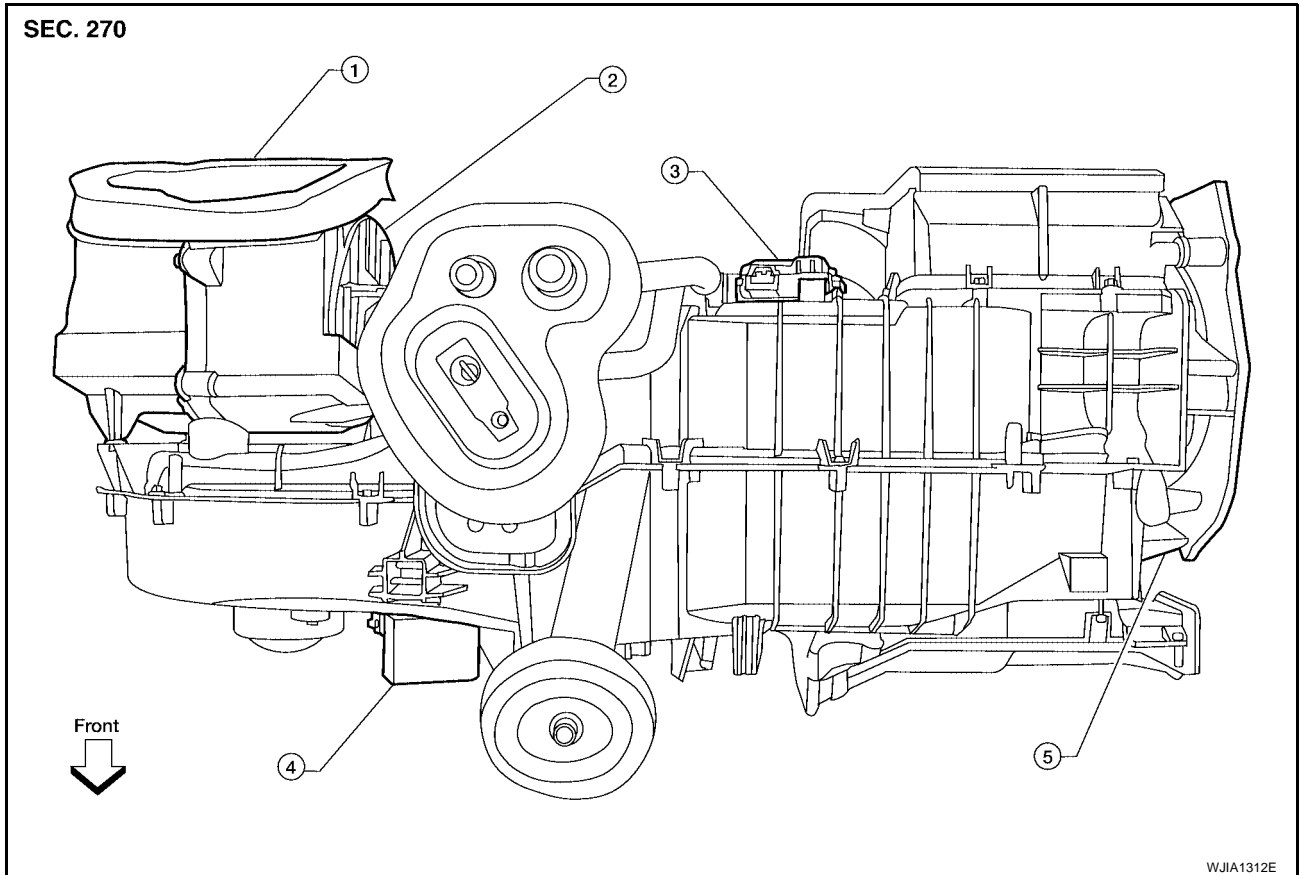

- | | | |
|-------------------------------------|----------------------|-----------------------|
| 1. Heater and cooling unit assembly | 2. Intake door motor | 3. Air mix door motor |
| 4. Blower motor resistor | 5. Mode door motor | |

REMOVAL

1. Remove the instrument panel side finisher. Refer to [IP-10, "INSTRUMENT PANEL ASSEMBLY"](#).
2. Remove the lower instrument cover. Refer to [IP-10, "INSTRUMENT PANEL ASSEMBLY"](#).
3. Disconnect the mode door motor electrical connector.
4. Remove the three screws and remove the mode door motor.

INSTALLATION

Installation is in the reverse order of removal.

A
B
C
D
E
F
G
H
I

MTC

K
L
M

AIR MIX DOOR MOTOR

AIR MIX DOOR MOTOR

PF2:27732

Components

EJS004S7

Air Mix Door Motor - Heater and Cooling Unit Assembly

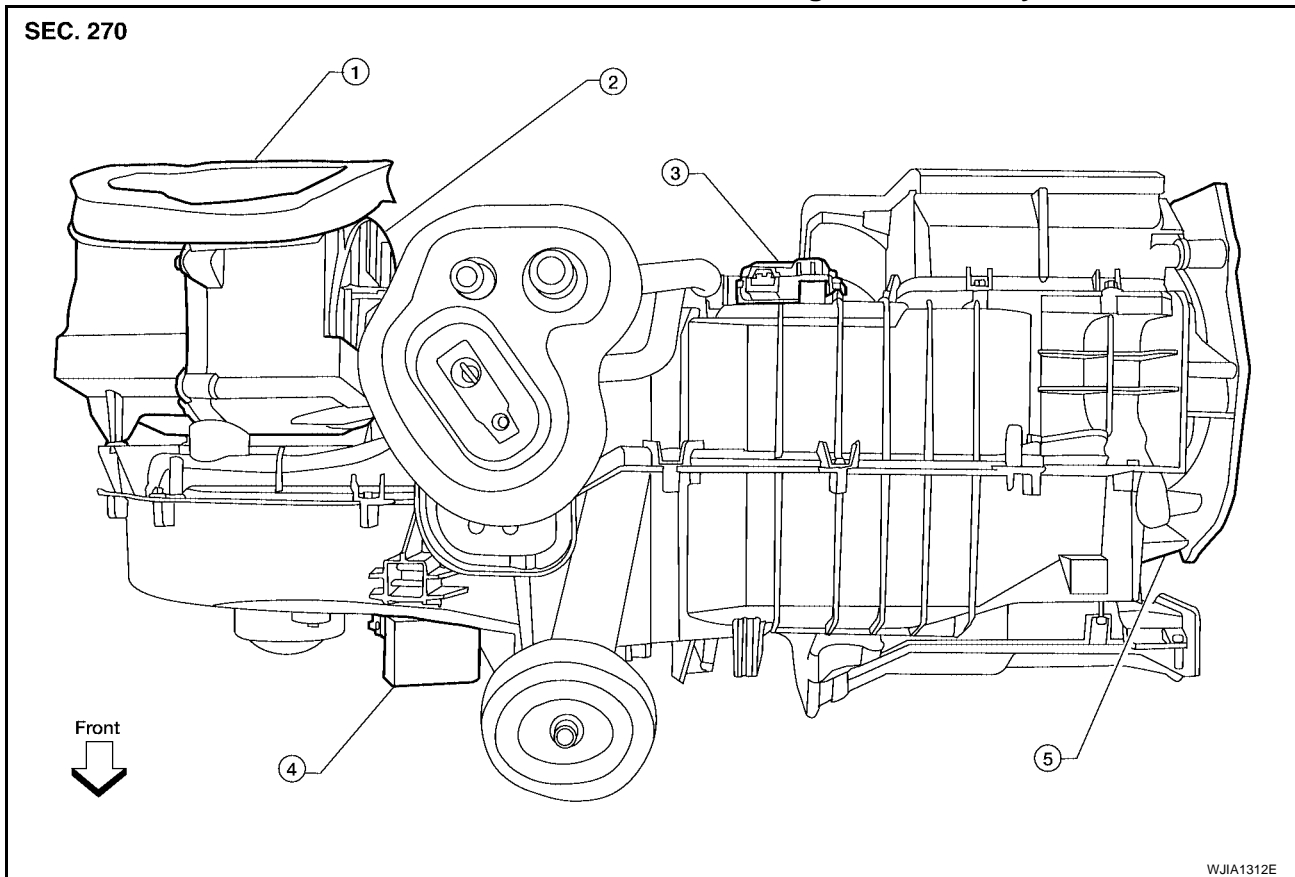

- | | | |
|-------------------------------------|----------------------|-----------------------|
| 1. Heater and cooling unit assembly | 2. Intake door motor | 3. Air mix door motor |
| 4. Blower motor resistor | 5. Mode door motor | |

Removal and Installation

EJS004S8

REMOVAL

1. Remove the heater and cooling unit assembly. Refer to [MTC-87, "HEATER & COOLING UNIT ASSEMBLY"](#).
2. Remove the steering member from the heater and cooling unit assembly.
3. Disconnect the air mix door motor electrical connector.
4. Remove the three screws and remove the air mix door motor.

INSTALLATION

Installation is in the reverse order of removal.

FRONT BLOWER MOTOR RESISTOR

FRONT BLOWER MOTOR RESISTOR

PFP:27077

Removal and Installation

EJS004S9

Blower Motor Resistor - Heater and Cooling Unit Assembly

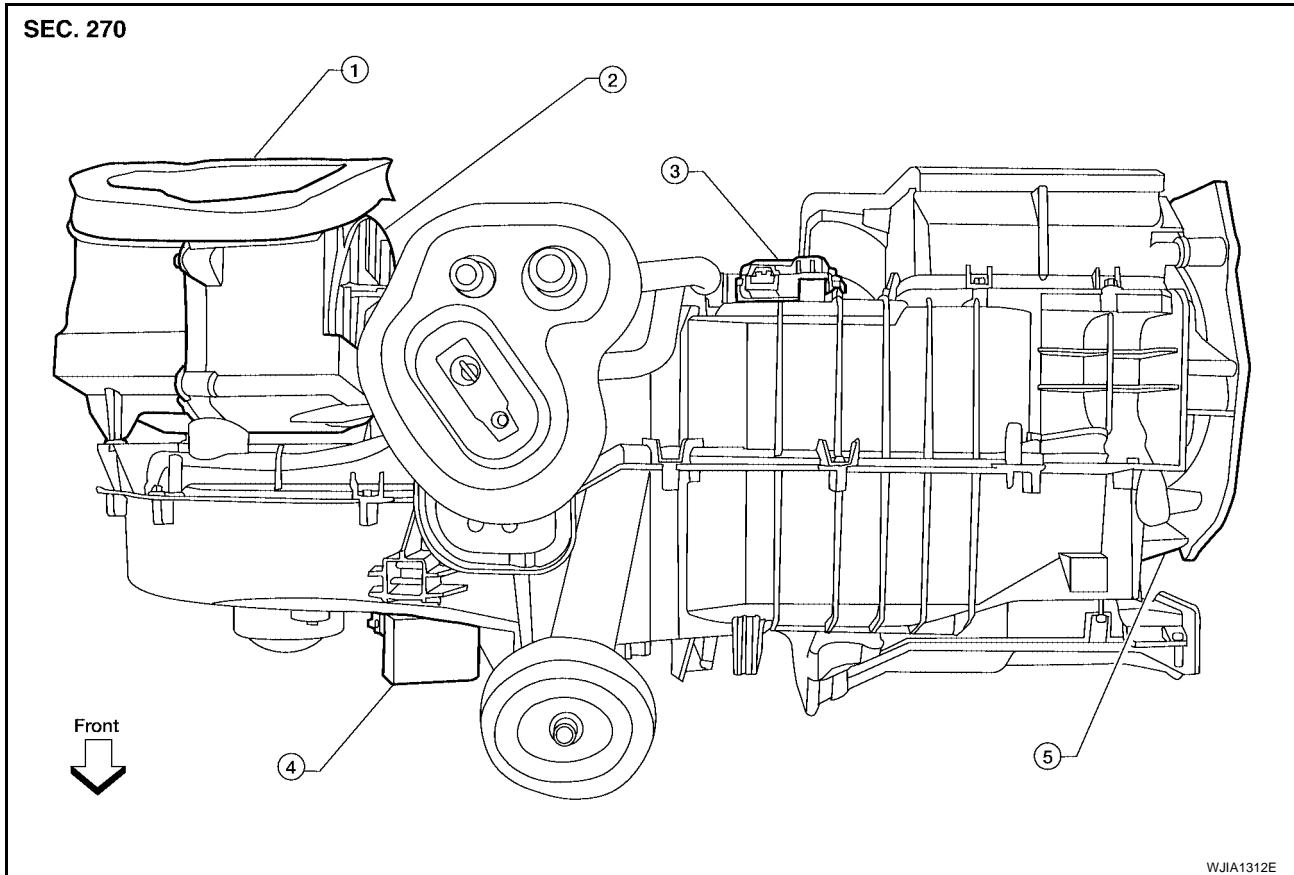

- | | | |
|-------------------------------------|----------------------|-----------------------|
| 1. Heater and cooling unit assembly | 2. Intake door motor | 3. Air mix door motor |
| 4. Blower motor resistor | 5. Mode door motor | |

REMOVAL

1. Disconnect the blower motor resistor electrical connector.
2. Remove the two screws and remove the blower motor resistor.

INSTALLATION

Installation is in the reverse order of removal.

A
B
C
D
E
F
G
H
I
K
L
M

MTC

DUCTS AND GRILLES

DUCTS AND GRILLES

PF27860

Components

EJS004SA

SEC. 270 • 271

Ducts

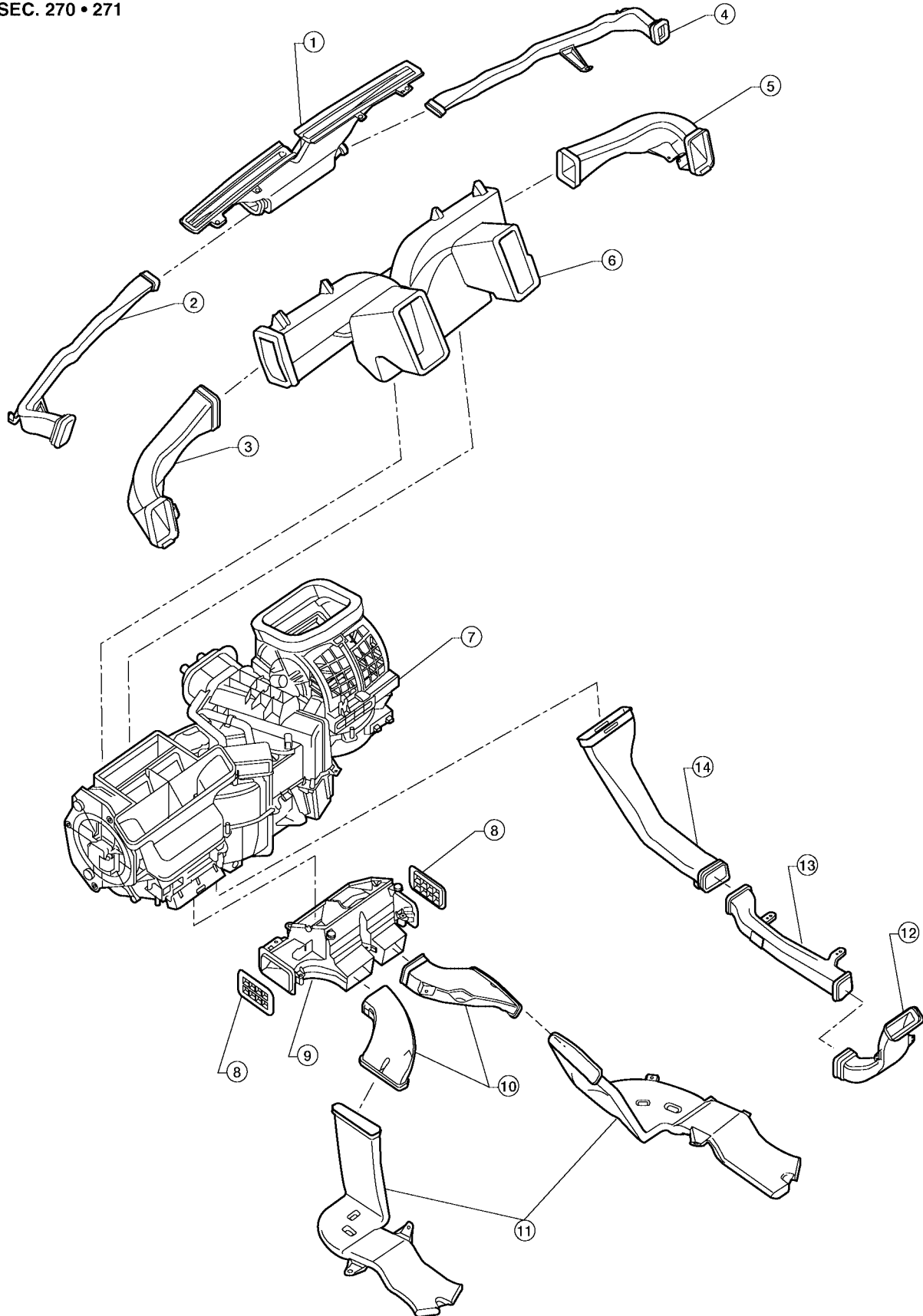

LJIA0155E

DUCTS AND GRILLES

- | | | |
|---|---------------------------------|---------------------------|
| 1. Defroster nozzle | 2. LH side demister duct | 3. LH ventilator duct |
| 4. RH side demister duct | 5. RH ventilator duct | 6. Center ventilator duct |
| 7. Front heater and cooling unit assembly | 8. Floor connector duct grilles | 9. Floor connector duct |
| 10. Front floor ducts | 11. Floor floor ducts | 12. Rear console duct |
| 13. Center console duct | 14. Front console duct | |

Grilles

SEC. 280 • 685 • 969

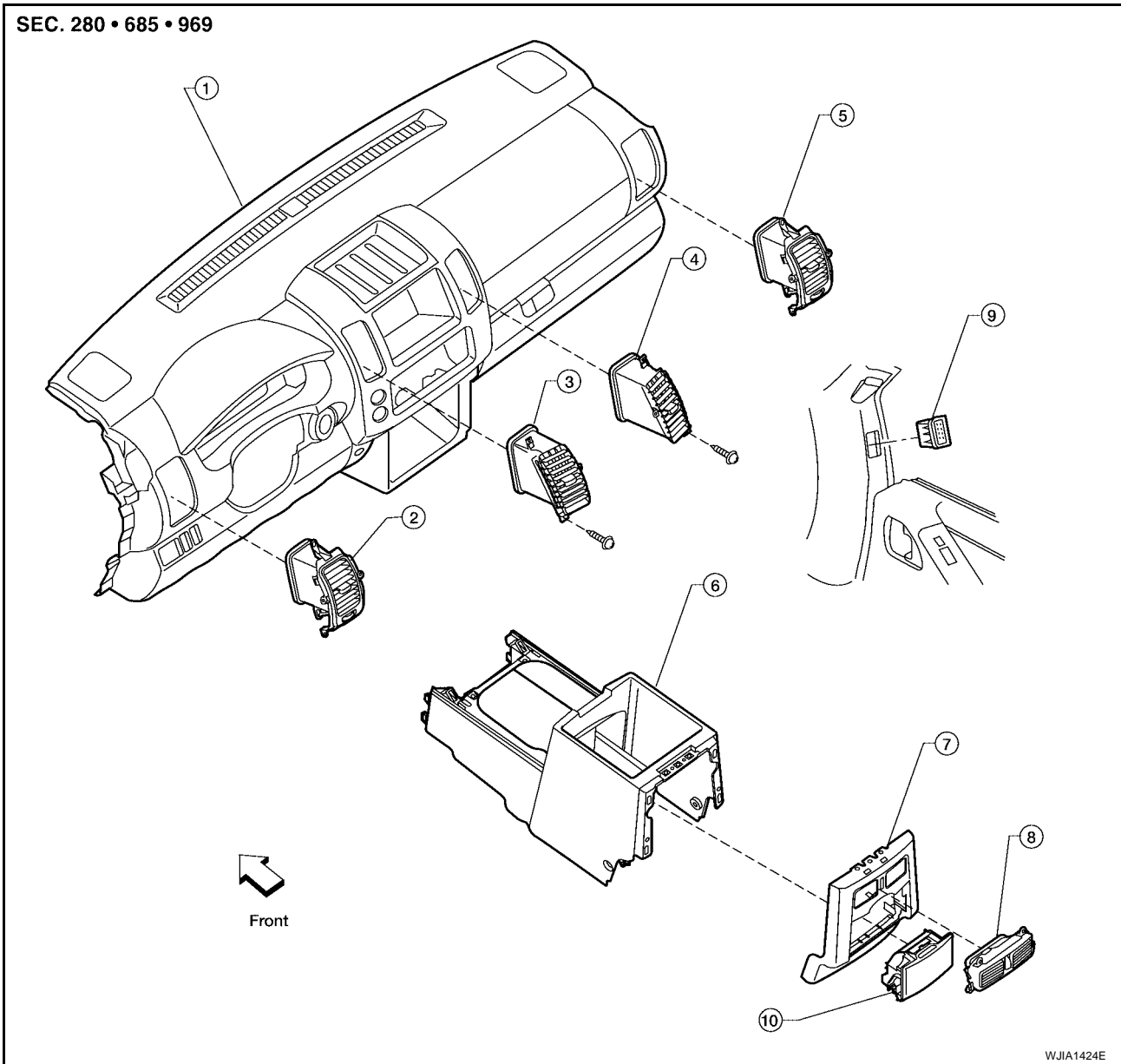

- | | | |
|--------------------------------------|------------------------------|-------------------------------|
| 1. Instrument panel and pad assembly | 2. LH side ventilator grille | 3. LH ventilator grille |
| 4. RH ventilator grille | 5. RH side ventilator grille | 6. Console assembly rear base |
| 7. Rear finisher assembly | 8. Console grille | 9. RH side demister grille |
| 10. Rear cup holder assembly | | |

Removal and Installation CONSOLE DUCTS AND CONSOLE GRILLE

EJS004SB

Removal

The center console must be removed and disassembled to remove the console ducts and the console grille. Refer to [IP-16, "CENTER CONSOLE"](#).

Installation

Installation is in the reverse order of removal.

A
B
C
D
E
F
G
H
I
MTC
K
L
M

DUCTS AND GRILLES

DEFROSTER NOZZLE

Removal

1. Remove the heater and cooling unit assembly. Refer to [MTC-87, "HEATER & COOLING UNIT ASSEMBLY"](#).
2. Remove the defroster nozzle.

Installation

Installation is in the reverse order of removal.

RH AND LH SIDE DEMISTER DUCTS

Removal

1. Remove the heater and cooling unit assembly. Refer to [MTC-87, "HEATER & COOLING UNIT ASSEMBLY"](#).
2. Remove the RH or LH side demister duct.

Installation

Installation is in the reverse order of removal.

RH AND LH VENTILATOR DUCTS

Removal

1. Remove the heater and cooling unit assembly. Refer to [MTC-87, "HEATER & COOLING UNIT ASSEMBLY"](#).
2. Remove the RH or LH ventilator duct.

Installation

Installation is in the reverse order of removal.

CENTER VENTILATOR DUCT

Removal

1. Remove the heater and cooling unit assembly. Refer to [MTC-87, "HEATER & COOLING UNIT ASSEMBLY"](#).
2. Remove the defroster nozzle.
3. Remove the RH and LH ventilator ducts.
4. Remove the RH and LH side demister ducts.
5. Remove the center ventilator duct.

Installation

Installation is in the reverse order of removal.

FLOOR CONNECTOR DUCT

Removal

1. Remove the heater and cooling unit assembly. Refer to [MTC-87, "HEATER & COOLING UNIT ASSEMBLY"](#).
2. Remove the floor connector duct.

Installation

Installation is in the reverse order of removal.

FRONT AND REAR FLOOR DUCTS

Removal

1. Remove the floor carpet. Refer to [EI-29, "FLOOR TRIM"](#).
2. Remove the clips and front and rear floor ducts.

Installation

Installation is in the reverse order of removal.

DUCTS AND GRILLES

GRILLES

Removal

1. Remove the interior trim panel as necessary that contains the grille to be removed. Refer to [IP-10, "INSTRUMENT PANEL ASSEMBLY"](#) and [EI-27, "BODY SIDE TRIM"](#).
2. Remove the grille from the interior trim panel.

Installation

Installation is in the reverse order of removal.

A

B

C

D

E

F

G

H

I

MTC

K

L

M

REFRIGERANT LINES

PF9:92600

EJS004SC

REFRIGERANT LINES

HFC-134a (R-134a) Service Procedure SETTING OF SERVICE TOOLS AND EQUIPMENT

Discharging Refrigerant

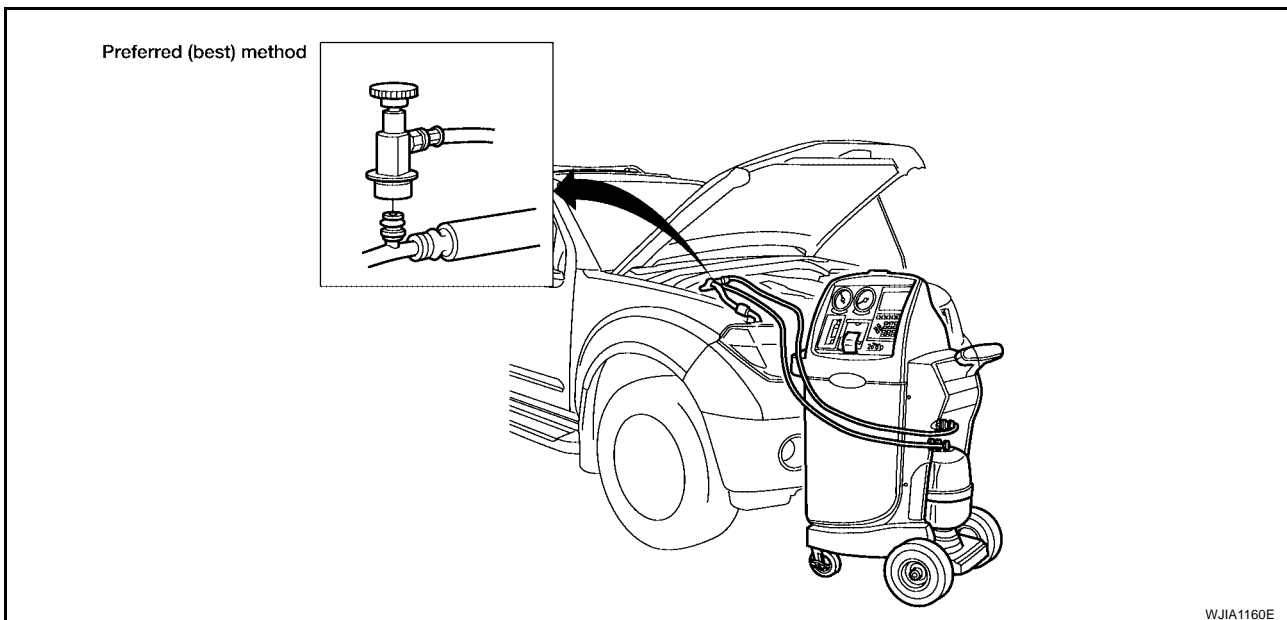

1. Shut-off valve
2. A/C service valve
3. Recovery/recycling equipment

WARNING:

Avoid breathing A/C refrigerant and oil vapor or mist. Exposure may irritate eyes, nose and throat. Remove HFC-134a (R-134a) refrigerant from the A/C system using certified service equipment meeting requirements of SAE J2210 HFC-134a (R-134a) recycling equipment or SAE J2201 HFC-134a (R-134a) recovery equipment. If an accidental system discharge occurs, ventilate the work area before resuming service. Additional health and safety information may be obtained from the refrigerant and oil manufacturers.

Evacuating System and Charging Refrigerant

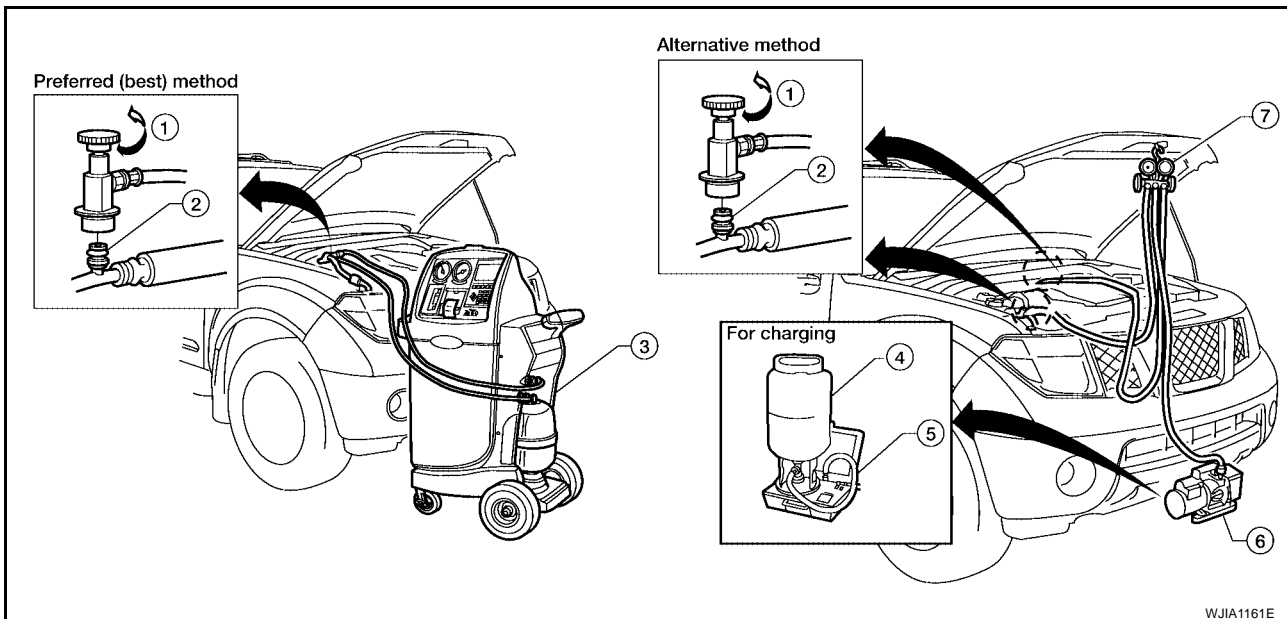

1. Shut-off valve
2. A/C service valve
3. Recovery/recycling equipment
4. Refrigerant container (HFC-134a)
5. Refrigerant weight scale (J-39699)
6. Vacuum pump (J-39649)
7. Manifold gauge set with hoses and couplers (J-39183-C)

REFRIGERANT LINES

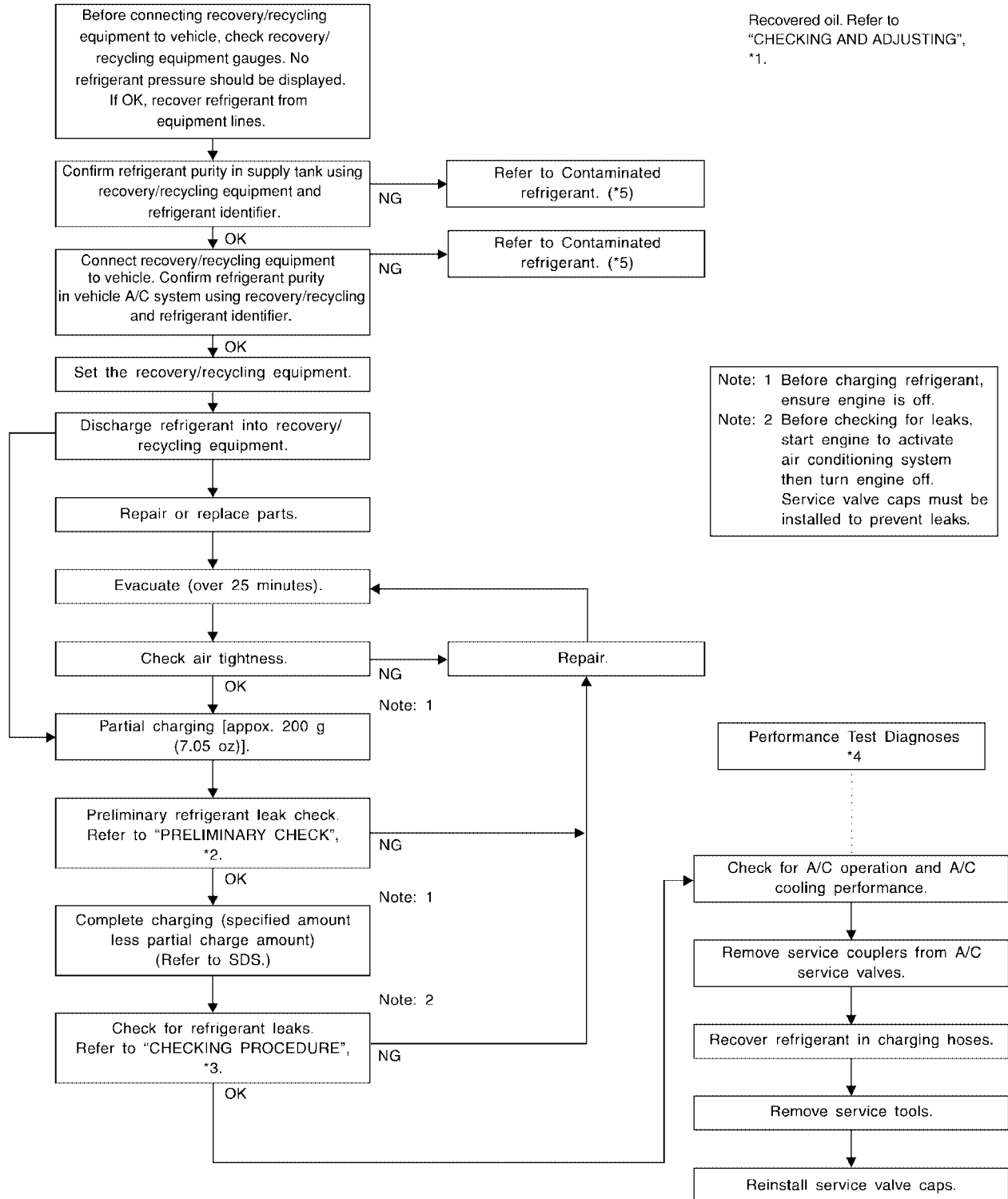

*1 [ATC-22, "CHECKING AND ADJUSTING"](#).

*2 [ATC-170, "Checking for Refrigerant Leaks"](#).

*3 [ATC-170, "Checking for Refrigerant Leaks"](#).

*4 [ATC-103, "PERFORMANCE TEST DIAGNOSES"](#).

*5 [ATC-5, "Contaminated Refrigerant"](#).

WJIA1923E

REFRIGERANT LINES

Components

EJS004SD

A/C Compressor and Condenser

SEC. 270 • 271 • 274 • 276 • 278

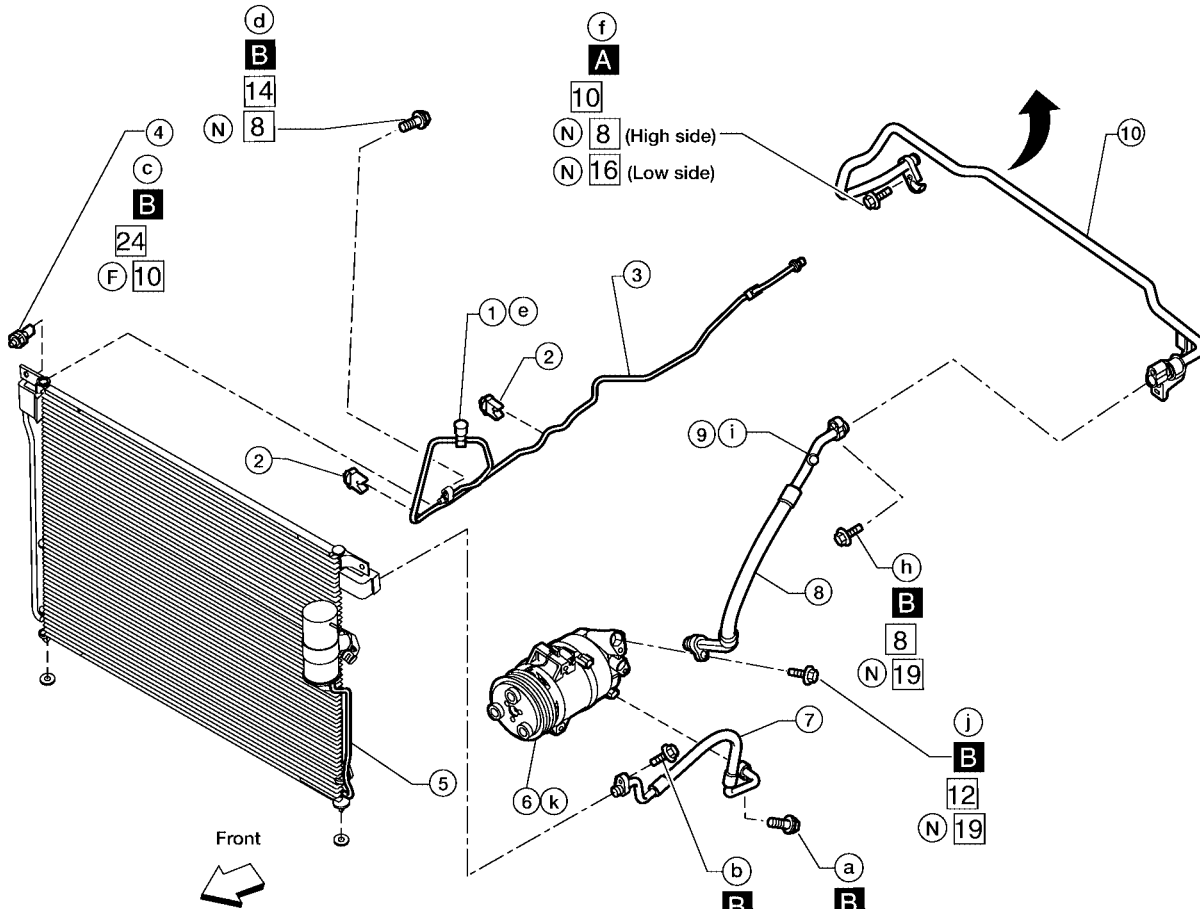
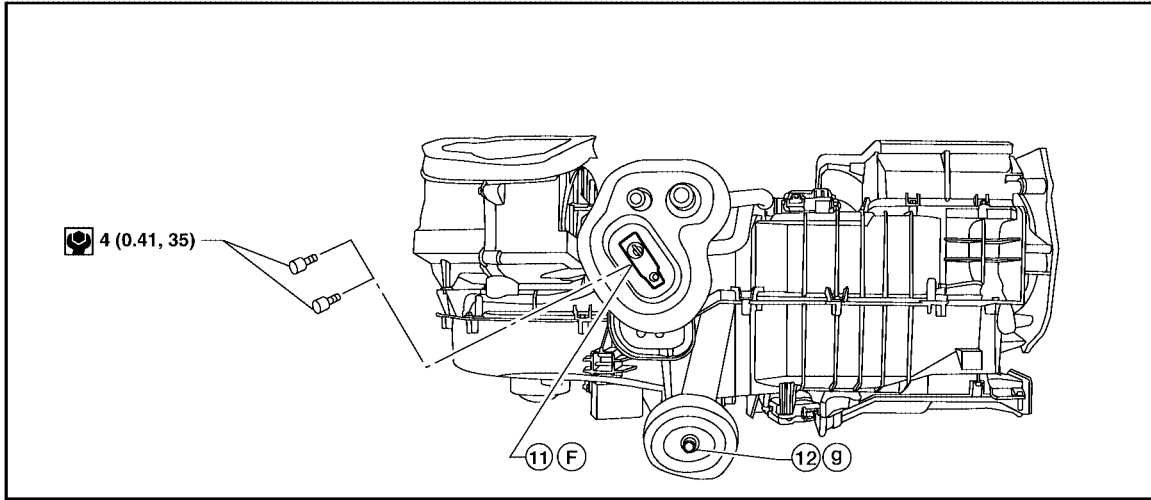

- : Refrigerant leak checking order (a-k)
- : Tightening torque
- : Wrench size
- : O-ring size
- ⊙ : N-m (kg-m, in-lb)
- A : 3.4 (0.35, 30)
- B : 9.3 (0.95, 82)
- (F) : Former type refrigerant connection
- (N) : New type refrigerant connection

WJJA1253E

REFRIGERANT LINES

- | | | |
|------------------------------------|-----------------------------------|-------------------------------|
| 1. High-pressure service valve | 2. Clip | 3. High-pressure A/C pipe |
| 4. Refrigerant pressure sensor | 5. Condenser | 6. Compressor shaft seal |
| 7. High-pressure flexible A/C hose | 8. Low-pressure flexible A/C hose | 9. Low-pressure service valve |
| 10. Low-pressure A/C pipe | 11. Expansion valve | 12. A/C drain hose |

NOTE:

Refer to [MTC-5, "Precautions for Refrigerant Connection"](#) .

Removal and Installation for Compressor COMPONENTS

EJS004SE

A/C Compressor Mounting

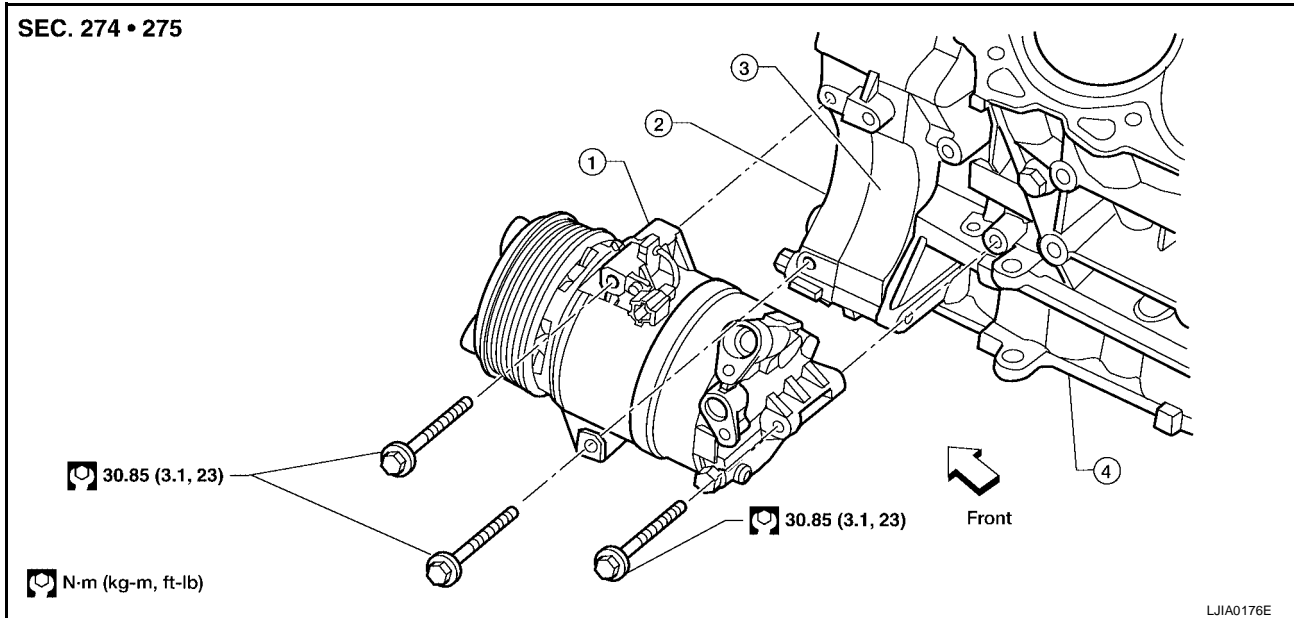

- | | | |
|-------------------|----------------------------|---------------------------|
| 1. Compressor | 2. Front timing chain case | 3. Rear timing chain case |
| 4. Cylinder block | | |

REMOVAL

1. Discharge the A/C refrigerant. Refer to [MTC-98, "HFC-134a \(R-134a\) Service Procedure"](#) .
2. Remove the front left wheel and tire assembly. Refer to [WT-7, "Rotation"](#) .
3. Remove the front left mud guard.
4. Remove the front left splash shield.
5. Remove the engine air cleaner and air ducts. Refer to [EM-16, "AIR CLEANER AND AIR DUCT"](#) .
6. Remove the drive belt. Refer to [EM-14, "DRIVE BELTS"](#) .
7. Disconnect the compressor harness connector.
8. Disconnect both the high-pressure flexible A/C hose and low-pressure flexible A/C hose from the compressor.

CAUTION:

Cap or wrap the joint of the pipe with suitable material such as vinyl tape to avoid the entry of air.

9. Remove the A/C compressor bolts using power tools.

INSTALLATION

Installation is in the reverse order of removal.

CAUTION:

- Replace the O-ring of the low-pressure flexible A/C hose and high-pressure flexible A/C hose with a new one, apply compressor oil to the O-rings before installation.
- After recharging the A/C system with refrigerant, check for leaks. Refer to [MTC-109, "Checking for Refrigerant Leaks"](#) .

REFRIGERANT LINES

5. Remove the pulley using Tool with a small adapter. Position the small adapter on the end of the drive shaft and the center of the pulley on the small adapter.

Tool number : KV99233130 (J-29884)

CAUTION:

To prevent deformation of the pulley groove, the puller claws should be hooked under the pulley groove and not into the pulley groove.

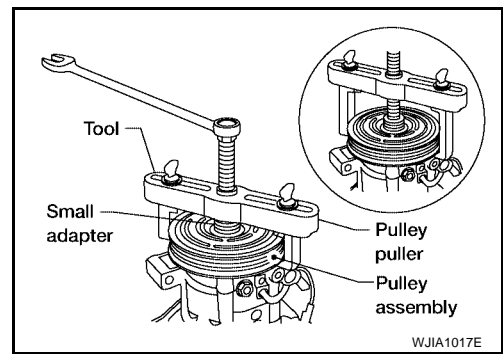

6. Remove the magnet coil harness clip using a screwdriver, remove the three magnet coil fixing screws and remove the magnet coil.

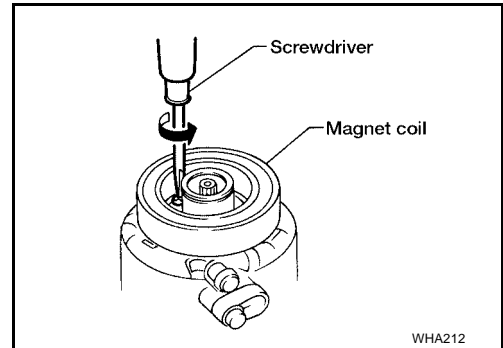

INSPECTION

Clutch Disc

If the contact surface shows signs of damage due to excessive heat, replace clutch disc and pulley.

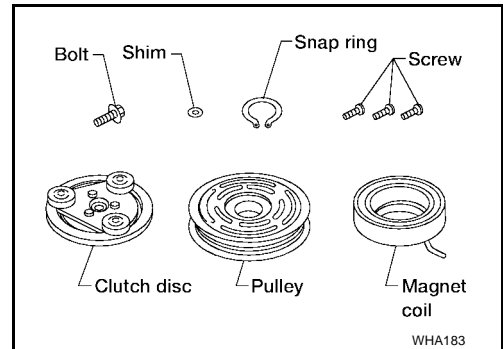

Pulley

Check the appearance of the pulley assembly. If contact surface of pulley shows signs of excessive grooving, replace clutch disc and pulley. The contact surfaces of the pulley assembly should be cleaned with a suitable solvent before reinstallation.

Coil

Check magnet coil for loose connections or any cracked insulation.

INSTALLATION

1. Install the magnet coil.

CAUTION:

Be sure to align the magnet coil pin with the hole in the compressor front head.

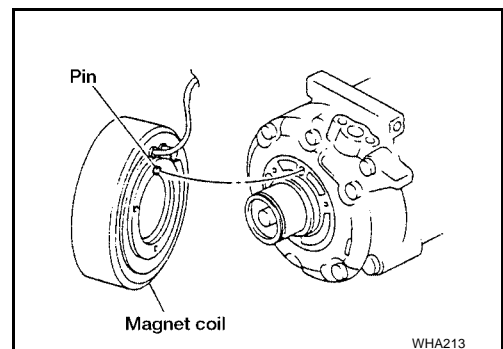

A
B
C
D
E
F
G
H
I
MTC
K
L
M

REFRIGERANT LINES

2. Install the magnet coil harness clip using a screwdriver.
3. Install the pulley assembly using Tool and a wrench, then install the snap ring using snap ring pliers.

Tool number : — (J-38873-A)

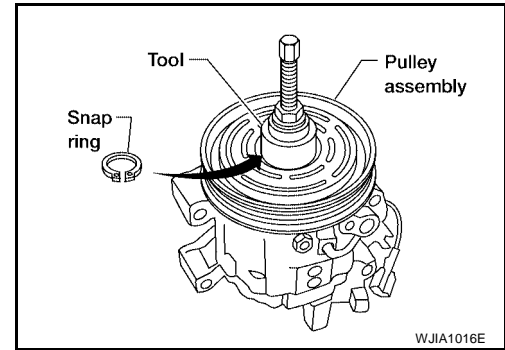

4. Install the clutch disc on the compressor shaft, together with the original shim(s). Press the clutch disc down by hand.

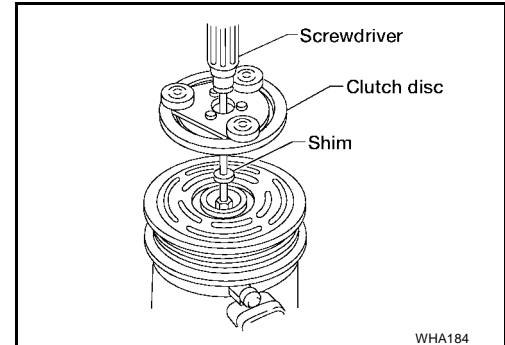

5. Install the clutch pulley bolt using Tool, to prevent the clutch disc from turning and tighten the bolt to specification. Refer to [MTC-101, "COMPONENTS"](#).

Tool number : J-44614

CAUTION:

After tightening the clutch pulley bolt, check that the clutch pulley rotates smoothly.

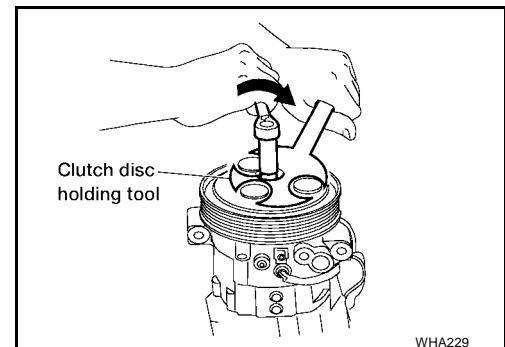

6. Check the pulley clearance all the way around the clutch disc as shown.

Clutch disc-to-pulley clearance : 0.3 - 0.6 mm
(0.012 - 0.024 in)

7. If the specified clearance is not obtained, replace the adjusting spacer to readjust.
8. Install the compressor. Refer to [MTC-101, "Removal and Installation for Compressor"](#).

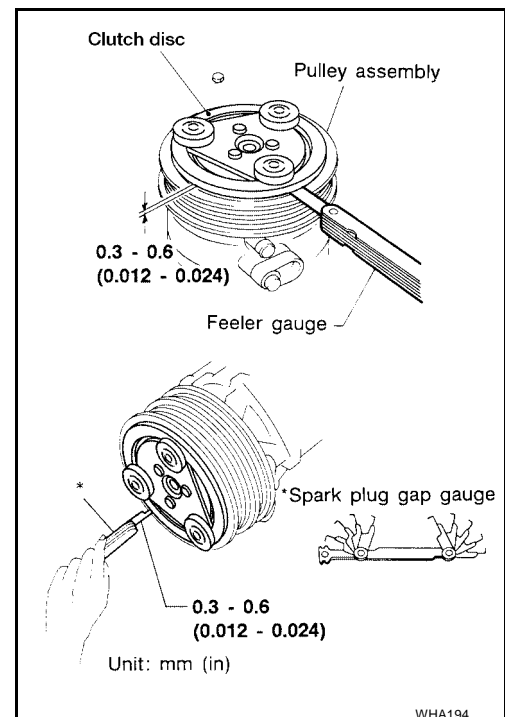

REFRIGERANT LINES

BREAK-IN OPERATION

When replacing compressor clutch assembly, always conduct the break-in operation. This is done by engaging and disengaging the clutch about 30 times. Break-in operation raises the level of transmitted torque.

Removal and Installation for High-pressure Flexible A/C Hose

EJS004SG

REMOVAL

1. Remove the front left wheel and tire assembly. Refer to [WT-7, "Rotation"](#) .
2. Remove the front left mud guard.
3. Remove the front left splash shield.
4. Discharge the refrigerant. Refer to [MTC-98, "HFC-134a \(R-134a\) Service Procedure"](#) .
5. Remove the high-pressure flexible A/C hose. Refer to [MTC-105, "Removal and Installation for High-pressure Flexible A/C Hose"](#) .

CAUTION:

Cap or wrap the joint of the pipe with suitable material such as vinyl tape to avoid the entry of air.

INSTALLATION

Installation is in the reverse order of removal.

Refer to [MTC-100, "Components"](#) .

CAUTION:

- Replace the O-ring of the high-pressure flexible A/C hose with a new one, then apply compressor oil to it for installation.
- After charging refrigerant, check for leaks.

Removal and Installation for High-pressure A/C Pipe

EJS004SH

REMOVAL

1. Remove the front right wheel and tire assembly. Refer to [WT-7, "Rotation"](#) .
2. Remove the front right mud guard.
3. Remove the front right splash shield.
4. Discharge the refrigerant. Refer to [MTC-98, "HFC-134a \(R-134a\) Service Procedure"](#) .
5. Remove the low pressure A/C pipe. Refer to [MTC-106, "Removal and Installation for Low-pressure A/C Pipe"](#) .
6. Remove the high-pressure A/C pipe. Refer to [MTC-100, "Components"](#) .

CAUTION:

Cap or wrap the joint of the pipe with suitable material such as vinyl tape to avoid the entry of air.

INSTALLATION

Installation is in the reverse order of removal.

Refer to [MTC-100, "Components"](#) .

CAUTION:

- Replace the O-ring of the high-pressure A/C pipe with a new one, then apply compressor oil to it for installation.
- After charging refrigerant, check for leaks.

Removal and Installation for Low-pressure Flexible A/C Hose

EJS004SI

REMOVAL

1. Remove the front right wheel and tire assembly. Refer to [WT-7, "Rotation"](#) .
2. Remove the front right mud guard.
3. Remove the front right splash shield.
4. Discharge the refrigerant. Refer to [MTC-98, "HFC-134a \(R-134a\) Service Procedure"](#) .

CAUTION:

Cap or wrap the joint of the pipe with suitable material such as vinyl tape to avoid the entry of air.

5. Remove the low-pressure flexible A/C hose. Refer to [MTC-105, "Removal and Installation for Low-pressure Flexible A/C Hose"](#) .

INSTALLATION

Installation is in the reverse order of removal.

REFRIGERANT LINES

Refer to [MTC-100, "Components"](#) .

CAUTION:

- Replace the O-ring of the low-pressure flexible A/C hose with a new one, then apply compressor oil to it for installation.
- After charging refrigerant, check for leaks.

Removal and Installation for Low-pressure A/C Pipe

EJS004SJ

REMOVAL

1. Discharge the refrigerant. Refer to [MTC-98, "HFC-134a \(R-134a\) Service Procedure"](#) .
2. Remove the low-pressure A/C pipe. Refer to [MTC-100, "Components"](#) .

CAUTION:

Cap or wrap the joint of the pipe with suitable material such as vinyl tape to avoid the entry of air.

INSTALLATION

Installation is in the reverse order of removal.

Refer to [MTC-100, "Components"](#) .

CAUTION:

- Replace the O-ring of the low-pressure A/C pipe with a new one, then apply compressor oil to it for installation.
- After charging refrigerant, check for leaks.

Removal and Installation for Refrigerant Pressure Sensor

EJS004SK

REMOVAL

1. Discharge the refrigerant. Refer to [MTC-98, "HFC-134a \(R-134a\) Service Procedure"](#) .
2. Disconnect the refrigerant pressure sensor harness connector and remove the refrigerant pressure sensor from the condenser.

CAUTION:

Be careful not to damage the condenser fins.

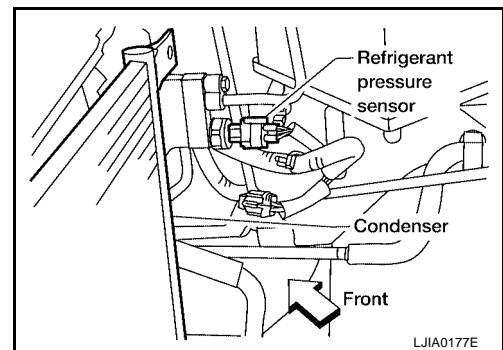

INSTALLATION

Installation is in the reverse order of removal.

Refer to [MTC-100, "Components"](#) .

CAUTION:

- Replace the O-ring of the refrigerant pressure sensor with a new one, then apply compressor oil to it for installation.
- Be careful not to damage the condenser fins.
- After charging refrigerant, check for leaks.

Removal and Installation for Condenser

EJS004SL

REMOVAL

1. Discharge the refrigerant. Refer to [MTC-98, "HFC-134a \(R-134a\) Service Procedure"](#) .
2. Remove the radiator. Refer to [CO-14, "RADIATOR"](#) .

CAUTION:

Be careful not to damage the core surface of the condenser and the radiator.

3. Disconnect the high-pressure flexible A/C hose and the high-pressure A/C pipe from the condenser.

CAUTION:

Cap or wrap the joint of the pipes with suitable material such as vinyl tape to avoid the entry of air.

REFRIGERANT LINES

4. Disconnect the refrigerant pressure sensor harness connector.
5. Remove the refrigerant pressure sensor from the condenser.
6. Lift the condenser out of the mounting grommets and remove the condenser.

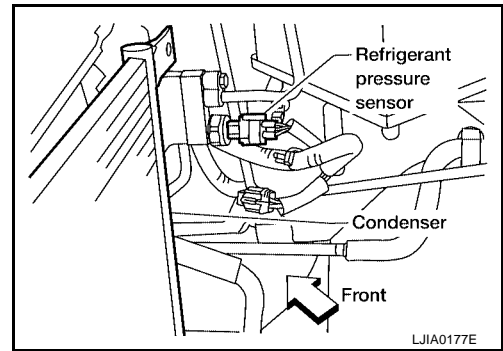

INSTALLATION

Installation is in the reverse order of removal.
Refer to [MTC-100, "Components"](#).

CAUTION:

- Replace the O-rings of the high-pressure A/C pipe, refrigerant pressure sensor, and high-pressure flexible A/C hose with new ones, then apply compressor oil to them for installation.
- After charging refrigerant, check for leaks.
- Replace the mounting grommets as necessary.

A
B
C
D
E
F
G
H
I

MTC

K
L
M

REFRIGERANT LINES

Removal and Installation for Evaporator

EJS004SM

Heater and Cooling Unit Assembly

SEC. 270 • 271 • 272

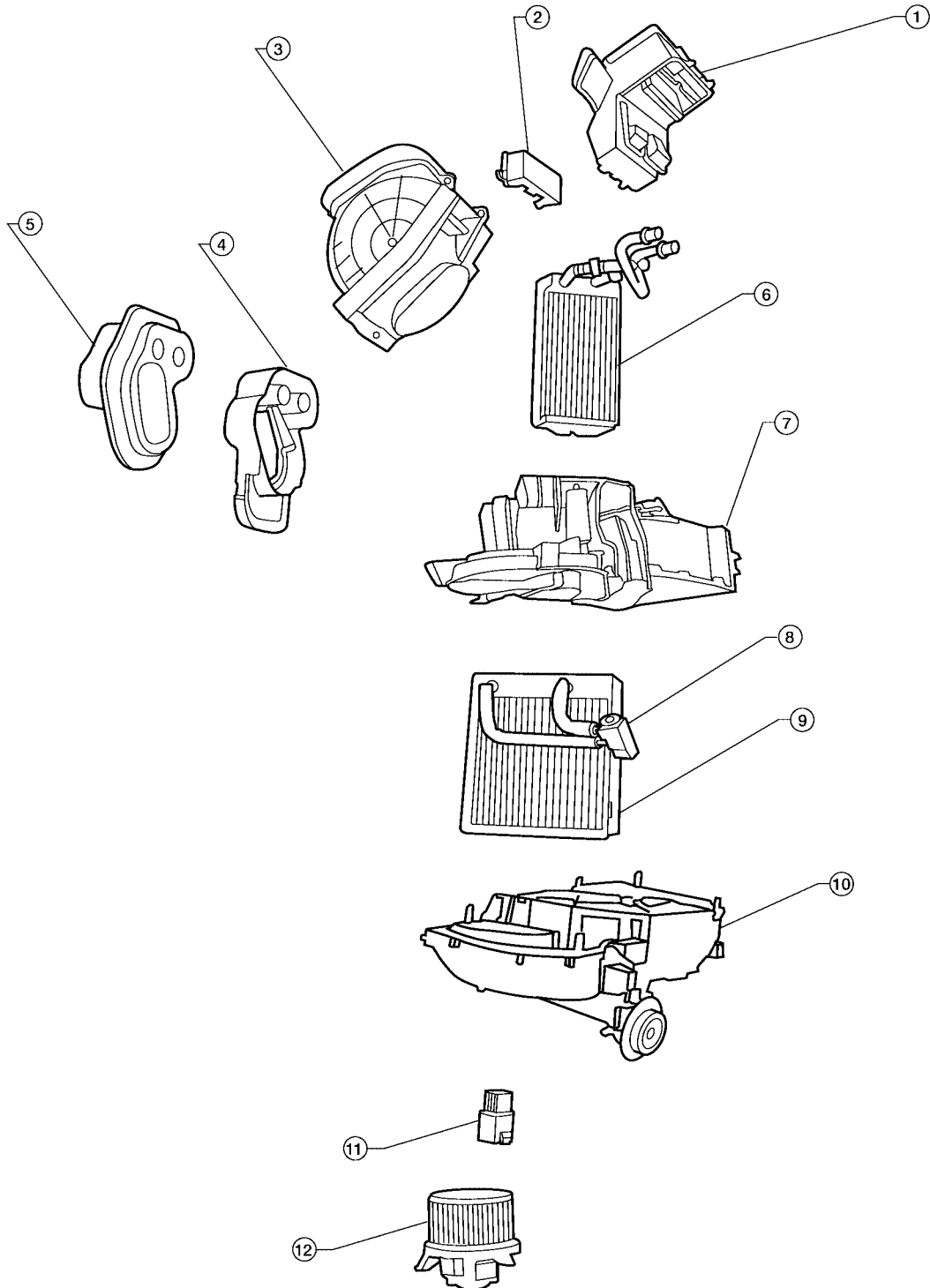

- | | | |
|---|-------------------------------------|--------------------|
| 1. Center ventilator connector duct | 2. Heater core cover | 3. Intake air case |
| 4. Heater core and evaporator pipes bracket | 5. Heater core and evaporator pipes | 6. Heater core |
| 7. Upper heater and cooling unit case | 8. Expansion valve | 9. Evaporator |
| 10. Lower heater and cooling unit case | 11. Blower motor resistor | 12. Blower motor |

LJIA0178E

REFRIGERANT LINES

REMOVAL

1. Remove the heater core. Refer to [MTC-89, "HEATER CORE"](#) .
2. Separate the heater and cooling unit case.
3. Remove the evaporator.

INSTALLATION

Installation is in the reverse order of removal.

CAUTION:

Replace the O-rings on the A/C low-pressure flexible A/C hose and the high-pressure A/C pipe with new ones. Apply compressor oil to the O-rings for installation.

Removal and Installation for Expansion Valve

EJS004SN

REMOVAL

1. Discharge the refrigerant. Refer to [MTC-98, "HFC-134a \(R-134a\) Service Procedure"](#) .
2. Remove the heater and cooling unit assembly. Refer to [MTC-87, "HEATER & COOLING UNIT ASSEMBLY"](#) .
3. Remove the heater core and evaporator pipes grommet.
4. Remove the expansion valve.

INSTALLATION

Installation is in the reverse order of removal.

Expansion valve bolts : Refer to [MTC-100, "Components"](#)

A/C refrigerant pipe to expansion valve bolt : Refer to [MTC-100, "Components"](#)

CAUTION:

- **Replace the O-rings on then expansion valve and the A/C refrigerant pipes with new ones, then apply compressor oil to them for installation.**
- **After charging refrigerant, check for leaks.**

Checking for Refrigerant Leaks

EJS004SO

Perform a visual inspection of all refrigeration parts, fittings, hoses and components for signs of A/C oil leakage, damage, and corrosion. Any A/C oil leakage may indicate an area of refrigerant leakage. Allow extra inspection time in these areas when using either an electronic refrigerant leak detector (J-41995) or fluorescent dye leak detector (J-42220).

If any dye is observed using a fluorescent dye leak detector (J-42220), confirm the leak using a electronic refrigerant leak detector (J-41995). It is possible that the dye is from a prior leak that was repaired and not properly cleaned.

When searching for leaks, do not stop when one leak is found but continue to check for additional leaks at all system components and connections.

When searching for refrigerant leaks using an electronic refrigerant leak detector (J-41995), move the probe along the suspected leak area at 25 - 50 mm (1 - 2 in) per second and no further than 6 mm (1/4 in) from the component.

CAUTION:

Moving the electronic refrigerant leak detector probe slower and closer to the suspected leak area will improve the chances of finding a leak.

Checking System for Leaks Using the Fluorescent Dye Leak Detector

EJS004SP

1. Check the A/C system for leaks using the fluorescent dye leak detector and safety goggles (J-42220) in a low sunlight area (area without windows preferable). Illuminate all components, fittings and lines. The dye will appear as a bright green/yellow area at the point of leakage. Fluorescent dye observed at the evaporator drain opening indicates an evaporator core assembly leak (tubes, core or expansion valve).
2. If the suspected area is difficult to see, use an adjustable mirror or wipe the area with a clean shop rag or cloth, then inspect the shop rag or cloth with the fluorescent dye leak detector (J-42220) for dye residue.
3. After the leak is repaired, remove any residual dye using refrigerant dye cleaner (J-43872) to prevent future misdiagnosis.

A

B

C

D

E

F

G

H

I

MTC

K

L

M

REFRIGERANT LINES

4. Perform a system performance check and then verify the leak repair using a electronic refrigerant leak detector (J-41995).

NOTE:

- Other gases in the work area or substances on the A/C components, for example, anti-freeze, windshield washer fluid, solvents and oils, may falsely trigger the leak detector. Make sure the surfaces to be checked are clean.
- Clean with a dry cloth or blow off with shop air.
- Do not allow the sensor tip of the electronic refrigerant leak detector (J-41995) to contact with any substance. This can also cause false readings and may damage the detector.

Dye Injection

EJS004SQ

NOTE:

This procedure is only necessary when recharging the system or when the compressor has seized and must be replaced.

1. Check the A/C system static (at rest) pressure. Pressure must be at least 345 kPa (3.52 kg/cm² , 50 psi).
2. Pour one bottle 7.4 cc (1/4 ounce) of the HFC-134a (R-134a) fluorescent leak detection dye (J-41447) into the HFC-134a (R-134a) refrigerant dye injector (J-41459).

CAUTION:

If repairing the A/C system or replacing a component, pour the HFC-134a (R-134a) fluorescent leak detection dye (J-41447) directly into the open system connection and proceed with the service procedures.

3. Connect the refrigerant dye injector (J-41459) to the low-pressure service valve.
4. Start the engine and switch the A/C system ON.
5. When the A/C system is operating (compressor running), inject one bottle 7.4 cc (1/4 ounce) of HFC-134a (R-134a) fluorescent leak detection dye (J-41447) through the low-pressure service valve using HFC-134a (R-134a) refrigerant dye injector (J-41459). Refer to the manufacturer's operating instructions.
6. With the engine still running, disconnect the HFC-134a (R-134a) refrigerant dye injector (J-41459) from the low-pressure service valve.
7. Operate the A/C system for a minimum of 20 minutes to mix the HFC-134a (R-134a) fluorescent leak detection dye (J-41447) with the A/C system oil. Depending on the leak size, operating conditions and location of the leak, it may take from minutes to days for the HFC-134a (R-134a) fluorescent leak detection dye to penetrate an A/C system leak and become visible.

Electronic Refrigerant Leak Detector PRECAUTIONS FOR HANDLING LEAK DETECTOR

EJS004SR

NOTE:

When performing a refrigerant leak check, use a electronic refrigerant leak detector (J-41995) or equivalent. Ensure that the electronic refrigerant leak detector (J-41995) is calibrated and set properly according to the manufacturer's operating instructions.

The electronic refrigerant leak detector (J-41995) is a delicate device. To use the electronic refrigerant leak detector (J-41995) properly, read the manufacturer's operating instructions and perform any specified maintenance.

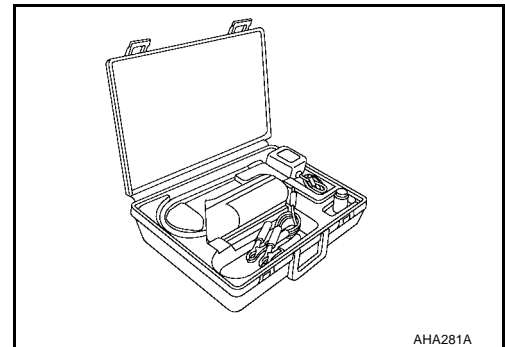

REFRIGERANT LINES

1. Position the probe approximately 5 mm (3/16 in) away from the point to be checked as shown.

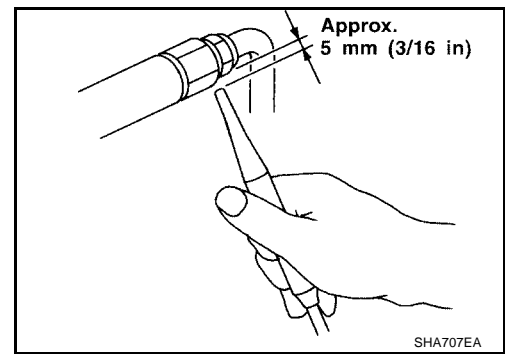

2. When checking for leaks, circle each fitting completely with the probe as shown.

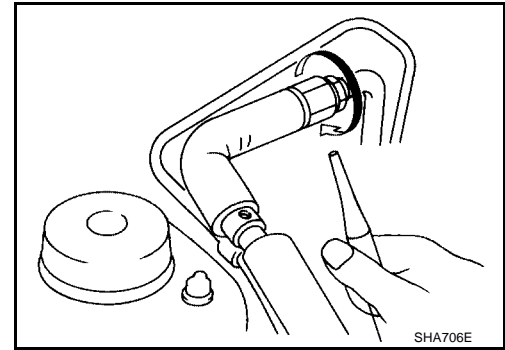

3. Move the probe along each component at a speed of approximately 25 - 50 mm (1 - 2 in)/second as shown.

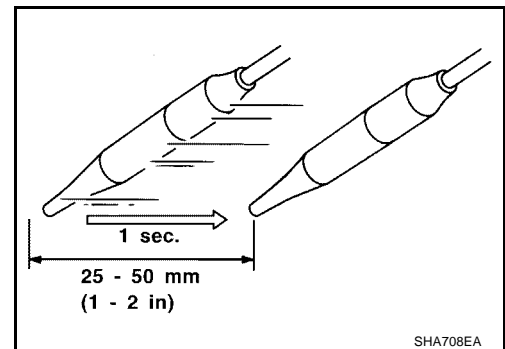

CHECKING PROCEDURE

NOTE:

To prevent inaccurate or false readings, make sure there is no refrigerant vapor, shop chemicals, or cigarette smoke in the vicinity of the vehicle. Perform the leak test in a calm area (low air/wind movement) so that the leaking refrigerant is not dispersed.

1. Turn the engine OFF.
2. Connect the manifold gauge set (J-39183-C) to the A/C service ports. Refer to [MTC-9, "Precautions for Service Equipment"](#).
3. Check if the A/C refrigerant pressure is at least 345 kPa (3.52 kg/cm², 50 psi) above a temperature of 16°C (61°F). If less than specification, recover/evacuate and recharge the system with the specified amount of refrigerant. Refer to [MTC-98, "HFC-134a \(R-134a\) Service Procedure"](#).

NOTE:

At temperatures below 16°C (61°F), leaks may not be detected since the system may not reach 345 kPa (3.52 kg/cm², 50 psi) pressure.

4. Perform the leak test from the high-pressure side (A/C compressor discharge "a" to evaporator inlet "f") to the low-pressure side (A/C evaporator drain hose "g" to shaft seal "k"). Refer to [MTC-100, "Components"](#). Clean the component to be checked and carefully move the electronic refrigerant leak detector probe completely around the following connections and components.

- Check the compressor shaft seal
- Check the high and low-pressure pipe and hose fittings, relief valve, and compressor shaft seal
- Check the liquid tank

REFRIGERANT LINES

- Check the refrigerant pressure sensor
- Check all around the service valves. Check that the service valve caps are screwed tightly on the service valves (to prevent leaks).

NOTE:

After removing manifold gauge set (J-39183-C) from the service valves, wipe any residue from the service valves to prevent any false readings by the electronic refrigerant leak detector (J-41995).

- Evaporator

With engine OFF, turn blower fan on "High" for at least 15 seconds to dissipate any refrigerant trace in the heater and cooling unit assembly. Wait a minimum of 10 minutes accumulation time (refer to the manufacturer's recommended procedure for actual wait time) before inserting the electronic refrigerant leak detector probe into the heater and cooling unit assembly drain hose.

NOTE:

Keep the probe inserted for at least 10 seconds. Use caution not to contaminate the probe tip with water or dirt that may be in the drain hose.

5. If a leak is detected, verify at least once by blowing compressed air into the area of the suspected leak, then repeat the leak check.
6. Do not stop when one leak is found. Continue to check for additional leaks at all system components and connections.
7. If no leaks are found, perform steps 8 - 11.
8. Start the engine.
9. Set the heater A/C controls as follows:
 - a. A/C switch: ON
 - b. Air flow: VENT mode
 - c. Intake position: RECIRCULATION mode
 - d. Temperature: MAX cold
 - e. Blower fan speed: HIGH
10. Run the engine at 1,500 rpm for at least 2 minutes.
11. Turn the engine OFF and perform the leak check again following steps 4 through 6 above.

Refrigerant leaks should be checked immediately after turning the engine OFF. Begin with the leak detector at the compressor. The pressure on the high pressure side will gradually drop after the refrigerant circulation stops and pressure on the low pressure side will gradually rise, as shown in the graph. Some leaks are more easily detected when the pressure is high.

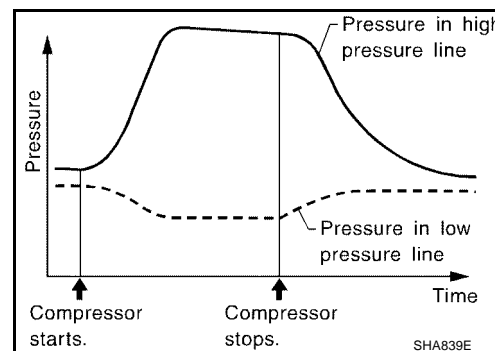

12. Before connecting the recovery/recycling equipment to the vehicle, check the recovery/recycling equipment gauges. No refrigerant pressure should be displayed. If pressure is displayed, recover the refrigerant from the equipment lines and then check the refrigerant purity.
13. Confirm refrigerant purity in supply tank using recovery/recycling equipment and refrigerant identifier equipment (J-41810-NI).
14. Confirm the refrigerant purity in the vehicle's A/C system using recovery/recycling equipment and refrigerant identifier equipment (J-41810-NI).
15. Discharge the A/C system using recovery/recycling equipment. Repair the leaking fitting or component as necessary.
16. Evacuate and recharge the A/C system and perform the leak test to confirm that there are no refrigerant leaks.
17. Conduct the Operational Check to ensure system works properly. Refer to [ATC-53, "Operational Check \(Front\)"](#).

SERVICE DATA AND SPECIFICATIONS (SDS)

SERVICE DATA AND SPECIFICATIONS (SDS)

PFP:00030

Service Data and Specifications (SDS) COMPRESSOR

EJS004SS

Make	CALSONIC KANSEI CO. LTD.
Model	DKS-17D
Type	Swash plate
Displacement	144 cm ³ (8.79 in ³) / revolution
Relief valve set pressure	3800 ± 300 kPa (38.76 ± 3.06 kg/cm ² , 551.0 ± 43.5 psi)
Direction of rotation	Clockwise (viewed from drive end)
Drive belt	Poly V ribbed

OIL

Description	NISSAN A/C System Oil Type S or equivalent
Capacity	180 mℓ (6.1 US fl oz, 6.3 Imp fl oz)

REFRIGERANT

Type	HFC 134a (R-134a)
Capacity	0.70 ± 0.05 kg (1.54 ± 0.11 lb)

ENGINE IDLING SPEED

Refer to [EC-75, "Idle Speed and Ignition Timing Check"](#) .

BELT TENSION

Refer to [MA-13, "DRIVE BELT TENSION"](#) .

A

B

C

D

E

F

G

H

I

MTC

K

L

M

SERVICE DATA AND SPECIFICATIONS (SDS)
