

SECTION **RAX**
REAR AXLE

A
B
C

RAX

CONTENTS

E

PRECAUTIONS	2	REAR DRIVE SHAFT	7	F
Caution	2	Components	7	
PREPARATION	3	Removal and Installation	7	
Special Service Tools (SST)	3	REMOVAL	7	G
Commercial Service Tools	3	INSPECTION AFTER REMOVAL	8	
NOISE, VIBRATION, AND HARSHNESS (NVH)		INSTALLATION	8	
TROUBLESHOOTING	4	Disassembly and Assembly	8	H
NVH Troubleshooting Chart	4	DISASSEMBLY	8	
WHEEL HUB	5	INSPECTION AFTER DISASSEMBLY	9	
On-Vehicle Inspection and Service	5	ASSEMBLY	10	
WHEEL BEARING INSPECTION	5	SERVICE DATA AND SPECIFICATIONS (SDS)	13	I
Components	5	Wheel Bearing	13	
Removal and Installation	5	Drive Shaft	13	J
REMOVAL	5			
INSTALLATION	6			

K
L
M

PRECAUTIONS

PRECAUTIONS

PFP:00001

Caution

EDS003AH

Observe the following precautions when disassembling and servicing drive shaft.

- Perform work in a location which is as dust-free as possible.
- Before disassembling and servicing, clean the outside of parts.
- Prevention of the entry of foreign objects must be taken into account during disassembly of the service location.
- Disassembled parts must be carefully reassembled in the correct order. If work is interrupted, a clean cover must be placed over parts.
- Paper shop cloths must be used. Fabric shop cloths must not be used because of the danger of lint adhering to parts.
- Disassembled parts (except for rubber parts) should be cleaned with kerosene which shall be removed by blowing with air or wiping with paper shop cloths.

PREPARATION

PREPARATION

PF0:00002

Special Service Tools (SST)

EDS003AI

The actual shapes of the Kent-Moore tools may differ from those of the special service tools illustrated here.

Tool number (Kent-Moore No.) Tool name	Description
KV38100500 (—) Drift	Installing drive shaft plug a: 80 mm (3.15 in) dia. b: 60 mm (2.36 in) dia.
KV38102200 (—) Drift	Installing drive shaft plug a: 90 mm (3.54 in) dia. b: 31 mm (1.22 in) dia.

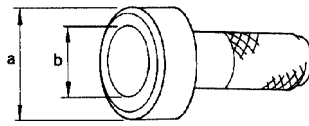

ZZA0701D

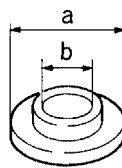

ZZA0920D

Commercial Service Tools

EDS003AJ

Tool name	Description
Power tools	Removing bolts and nuts

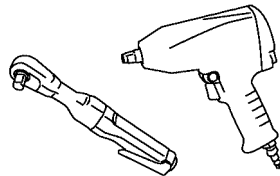

PBIC0190E

A
B
C
RAX
E
F
G
H
I
J
K
L
M

NOISE, VIBRATION, AND HARSHNESS (NVH) TROUBLESHOOTING

NOISE, VIBRATION, AND HARSHNESS (NVH) TROUBLESHOOTING

PF0:00003

NVH Troubleshooting Chart

EDS003AK

Use chart below to help you find the cause of the symptom. If necessary, repair or replace these parts.

Symptom		Possible cause and SUSPECTED PARTS													
		Excessive joint angle	Joint sliding resistance	Imbalance	Improper installation, looseness	Parts interference	REAR FINAL DRIVE	FRONT AXLE	FRONT SUSPENSION	REAR SUSPENSION	TIRES	ROAD WHEEL	PROPELLER SHAFT	BRAKES	STEERING
Reference page		—	RAX-8	—	RAX-5	—	RFD-7, "NVH Troubleshooting Chart"	FAX-4, "NVH Troubleshooting Chart"	FSU-4, "NVH Troubleshooting Chart"	RSU-4, "NVH Troubleshooting Chart"	WT-4, "NVH Troubleshooting Chart"	WT-4, "NVH Troubleshooting Chart"	PR-3, "NVH Troubleshooting Chart"	BR-5, "NVH Troubleshooting Chart"	PS-5, "NVH Troubleshooting Chart"
	Noise	x	x		x	x	x	x	x		x	x	x	x	x
	Shake	x		x	x	x		x	x		x	x	x	x	x
	Vibration				x	x		x	x	x	x	x			x
	Shimmy				x	x		x	x		x	x		x	x
	Shudder				x			x	x		x	x		x	x
Poor quality ride or handling					x	x		x	x	x	x	x			x

x: Applicable

WHEEL HUB

WHEEL HUB

PFP:43202

On-Vehicle Inspection and Service

EDS003AL

Inspect the components for any looseness or backlash. Inspect each component for any excessive wear or damage. Replace any components as necessary.

WHEEL BEARING INSPECTION

- Move the rear wheel hub and bearing assembly in the axial direction by hand to check the axial end play. Check that the axial end play is with specification. Replace the rear wheel hub and bearing assembly as necessary.

Axial end play : 0 mm (0 in)

- Rotate the rear wheel hub and bearing assembly to check that there are no unusual noises or other abnormal conditions. Replace the rear wheel hub and bearing assembly as necessary.

Components

EDS003AM

Rear Wheel Hub and Bearing Assembly

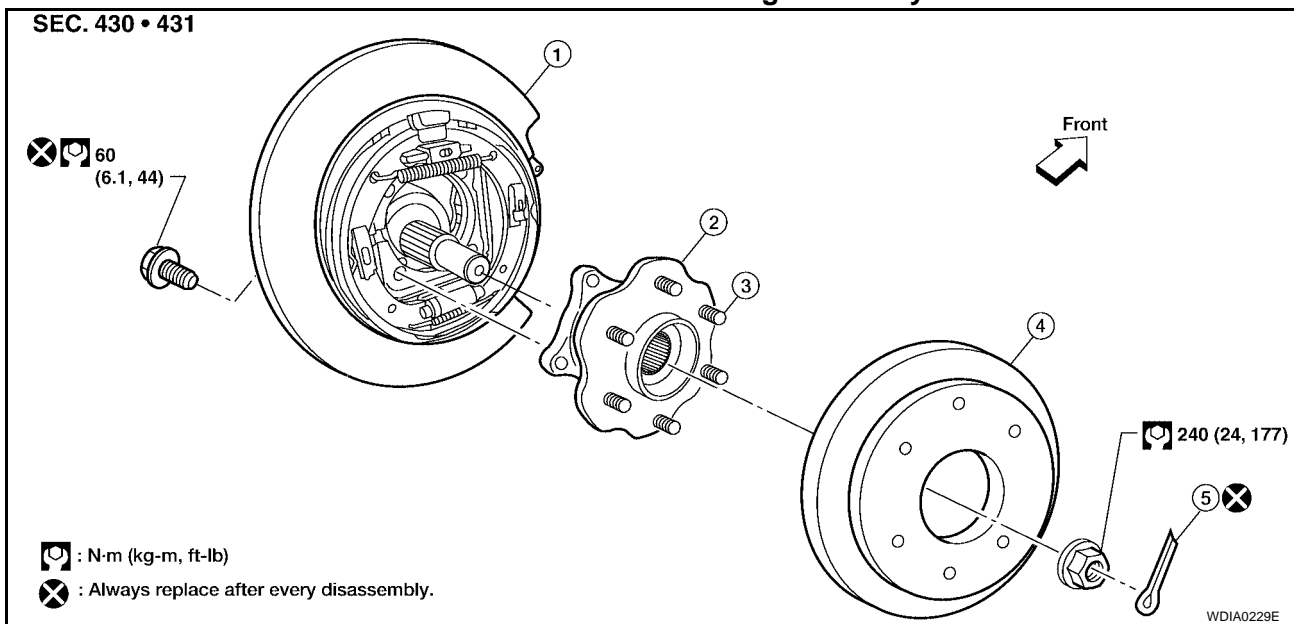

1. Back plate
2. Rear wheel hub and bearing assembly
3. Wheel stud
4. Rear disc rotor
5. Cotter pin

Removal and Installation

REMOVAL

EDS003AN

1. Remove the wheel and tire assembly using power tool.
2. Remove the rear brake caliper, without disconnecting the hydraulic hose, using power tool. Reposition the rear brake caliper aside using suitable wire. Refer to [BR-32, "Removal and Installation of Brake Caliper and Disc Rotor"](#).

NOTE:

Do not depress the brake pedal while the brake caliper is removed.

3. Remove the rear disc rotor.
4. Remove the cotter pin, then remove the rear drive shaft nut using power tool.
 - Discard the cotter pin, use a new one for installation.
5. Remove the rear drive shaft. Refer to [RAX-7, "Removal and Installation"](#).
6. Remove the four rear wheel hub and bearing assembly bolts using power tool.
 - Discard the four rear wheel hub and bearing assembly bolts, use new ones for installation.
7. Remove the rear wheel hub and bearing assembly.

WHEEL HUB

INSTALLATION

Installation is in the reverse order of removal.

- Use a new cotter pin for installation.
- Use new rear wheel hub and bearing assembly bolts for installation.

REAR DRIVE SHAFT

PFP:39600

EDS003A0

REAR DRIVE SHAFT

Components

Rear Drive Shaft Assembly

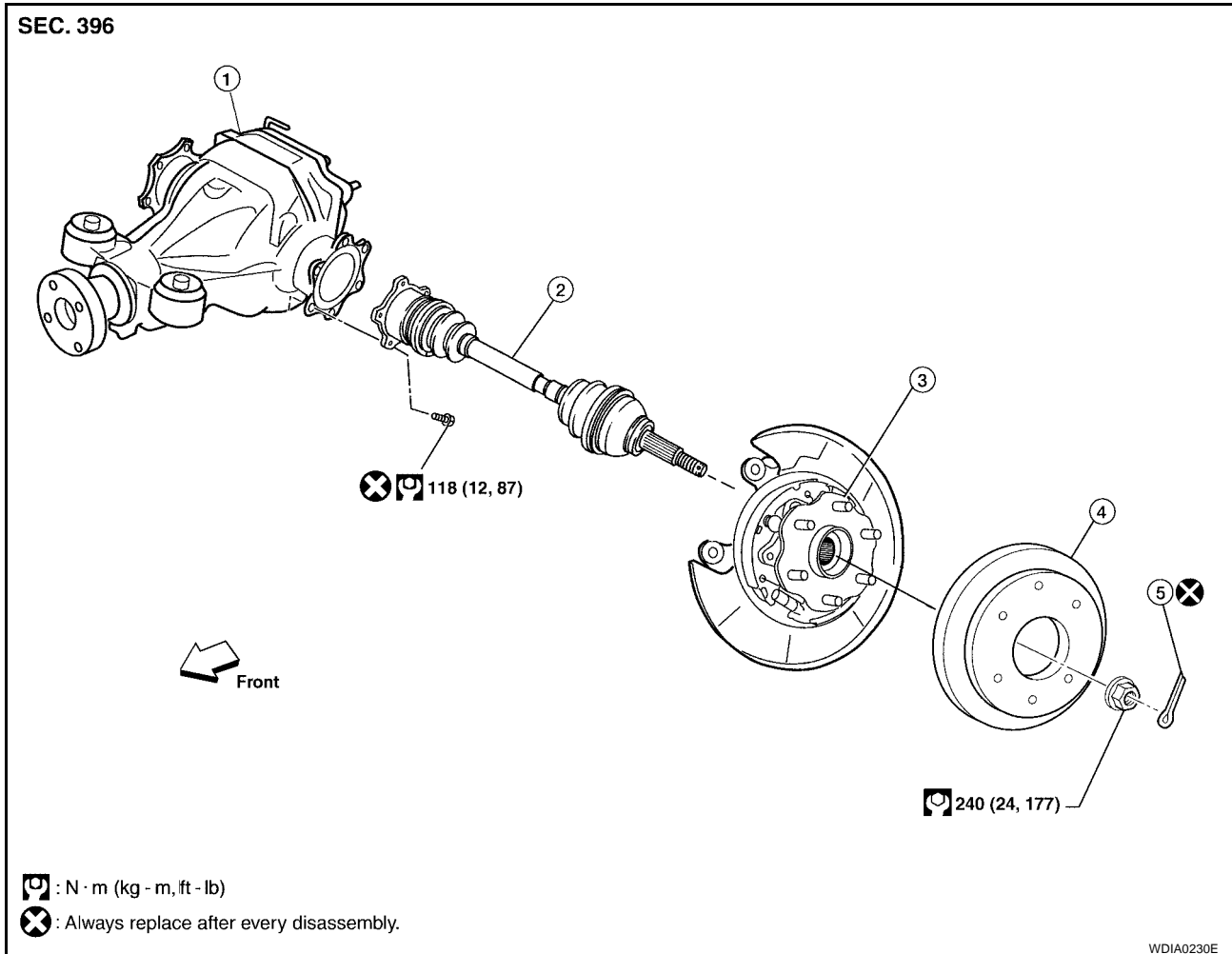

1. Rear final drive assembly
2. Rear drive shaft
3. Rear wheel hub and bearing assembly
4. Rear disc rotor
5. Cotter pin

Removal and Installation

REMOVAL

EDS003AP

1. Remove the wheel and tire assembly using power tool.
2. Remove the cotter pin and discard, then remove the lock nut from the drive shaft.
 - Do not reuse the cotter pin, discard after removal and use a new cotter pin for installation.
3. Remove the six rear drive shaft bolts from the rear final drive assembly flange using power tool.
 - Do not reuse the rear drive shaft bolts, discard after removal and use new bolts for installation.
4. Separate the rear drive shaft from the rear wheel hub and bearing assembly by lightly tapping the end of the rear drive shaft with a suitable hammer and wood block. If it is difficult to separate, use a suitable puller.
5. Remove the rear drive shaft.

CAUTION:

- When removing the rear drive shaft, do not bend at an excessive angle to the rear drive shaft joint.
- Do not excessively extend the slide joint.

A
B
C
RAX
E
F
G
H
I
J
K
L
M

REAR DRIVE SHAFT

INSPECTION AFTER REMOVAL

- Move the joint up and down, left and right, and in the axial direction. Check for any rough movement or significant looseness.
- Check the boot for cracks or other damage, and for any grease leakage.
- If necessary, disassemble the drive shaft, and repair as necessary.

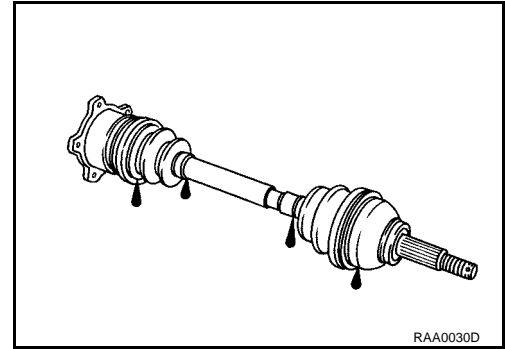

INSTALLATION

Installation is in the reverse order of removal.

- Do not reuse the drive shaft inside flange bolts and washers, discard after removal and use new bolts and washers for installation.
- Do not reuse the cotter pin, discard after removal and use a new cotter pin for installation.

Disassembly and Assembly

EDS003A0

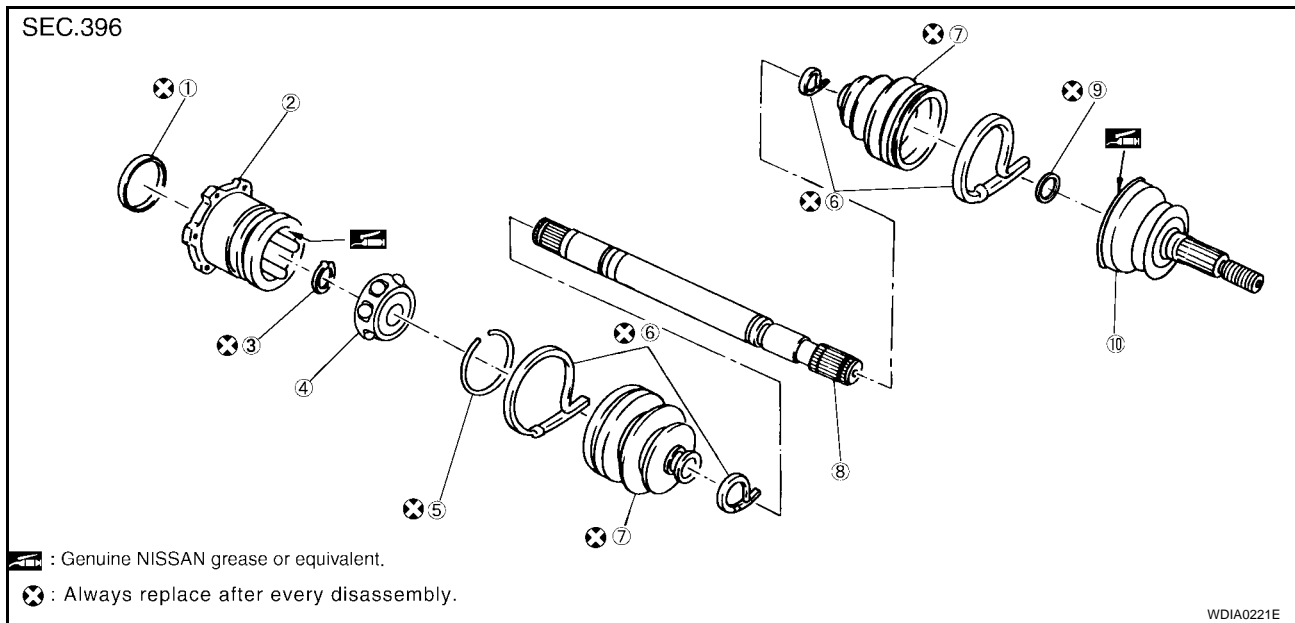

- | | | |
|--|-----------------|--------------|
| 1. Plug | 2. Housing | 3. Snap ring |
| 4. Ball cage, steel ball and liner race assembly | 5. Stopper ring | 6. Boot band |
| 7. Boot | 8. Shaft | 9. Circlip |
| 10. Joint sub-assembly | | |

DISASSEMBLY

Final Drive Side

1. Mount the drive shaft in a vise.

CAUTION:

When mounting the drive shaft in a vise, use copper or aluminum plates between the vise and the drive shaft.

2. Remove the boot bands.
3. If the plug needs to be removed, move the boot to the wheel side, then drive the plug out using a suitable plastic hammer.

REAR DRIVE SHAFT

- Remove the stopper ring with a flat-bladed screwdriver as shown, and pull the housing out.

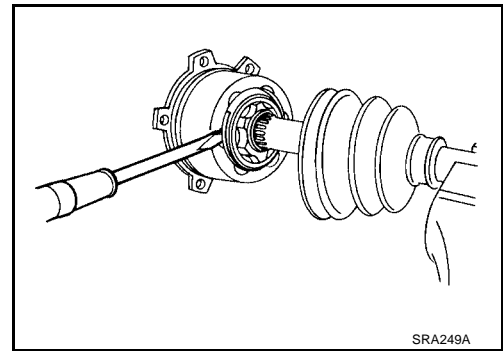

- Remove the snap ring, then remove the ball cage, steel ball and inner race assembly from the drive shaft.

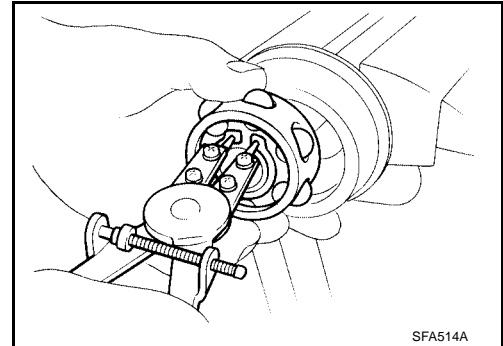

- Remove the boot from the drive shaft.
- Remove any old grease on the housing using paper towels.

Wheel Side

- Mount the drive shaft in a vise.

CAUTION:

When mounting the drive shaft in a vise, use copper or aluminum plates between the vise and the drive shaft.

- Remove the boot bands, then remove the boot from the joint sub-assembly.
- Screw a suitable drive shaft puller 30 mm (1.18 in) or more into the threaded part of the joint sub-assembly. Pull the joint sub-assembly out of the drive shaft as shown.

CAUTION:

- If the joint sub-assembly cannot be removed after five or more attempts, replace the drive shaft and joint sub-assembly as a set.
- Align the sliding hammer and drive shaft and remove the joint sub-assembly by pulling directly.

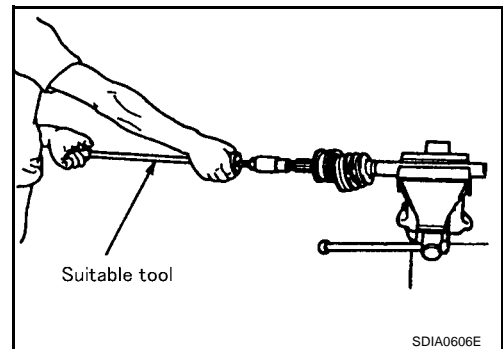

- Remove the boot from the drive shaft.
- Remove the circlip from the drive shaft.
- While rotating the ball cage, remove any old grease on the joint sub-assembly using paper towels.

INSPECTION AFTER DISASSEMBLY

Drive Shaft

- Replace the drive shaft if there is any runout, cracking, or other damage.

Joint Sub-assembly

- Check for any rough rotation or unusual axial looseness.
- Clean any foreign material from inside the joint sub-assembly.
- Check for any compression scars, cracks, or fractures.

A
B
C

RAX

E
F
G

H

I

J

K

L

M

REAR DRIVE SHAFT

CAUTION:

If any defective conditions are found in the joint sub-assembly components, replace the entire joint sub-assembly.

NOTE:

Install a new housing, ball cage, steel ball, and inner race as a set.

- Check for any compression scars, cracks, fractures, or unusual wear on the ball rolling surface.
- Check for any damage to the drive shaft screws.
- Check for any deformation of the boot installation components.

Ball Cage

- Check the sliding surface for any compression scars, cracks, or fractures.

Steel Ball

- Check for any compression scars, cracks, fractures, or unusual wear.

Inner Race

- Check the ball sliding surface for any compression scars, cracks, or fractures.
- Check for any damage to the serrated part.

ASSEMBLY

Final Drive Side

1. If the plug has been removed, use Tool to press in a new one.

Tool number : KV38100500 (—)
: KV38102200 (—)

NOTE:

Discard the old plug and use a new one for assembly.

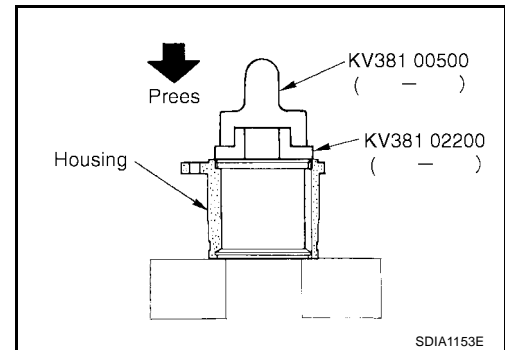

2. Wrap the serrated part of the shaft with tape. Install the boot band and boot to shaft.

NOTE:

Discard the old boot band and boot and use a new one for assembly.

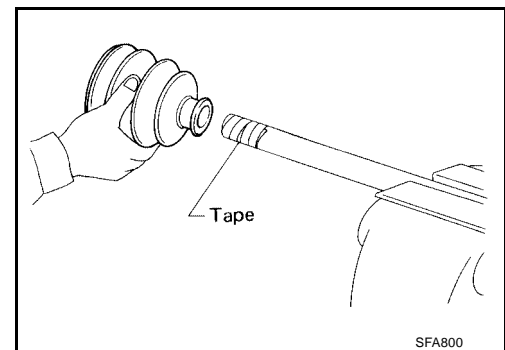

3. Remove the tape wound around the serrated part of the shaft.
4. Install the ball cage, steel ball, and inner race assembly on the shaft, and secure them tightly using the snap ring.

NOTE:

Discard the old snap ring and use a new one for assembly.

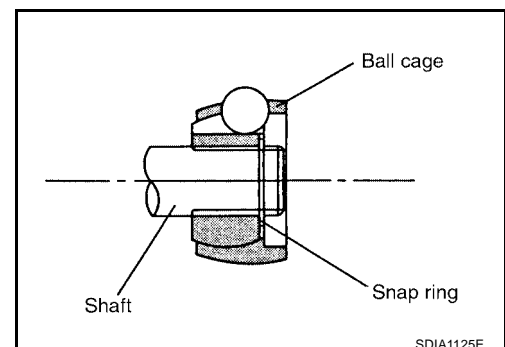

REAR DRIVE SHAFT

5. Insert the specified quantity of Genuine NISSAN Grease or equivalent, onto the housing (indicated by * marks), and install it onto shaft. Refer to [MA-11, "Fluids and Lubricants"](#) .

Grease capacity : 155 – 175 g (5.47 – 6.17 oz)

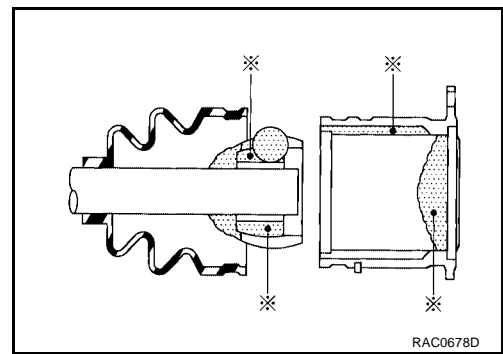

6. Install the stopper ring onto the housing.
 7. After installation, pull on the shaft to check engagement between the joint sub-assembly and the stopper ring.
 8. Install the boot securely into the grooves (indicated by * marks) as shown.

CAUTION:

If there is grease on boot mounting surfaces (indicated by * marks) of shaft and housing, boot may come off. Remove all grease from surfaces.

9. Check that the boot installation length "L" is the length indicated below. Insert a flat-bladed screwdriver or similar tool into larger side of boot. Bleed the air from the boot to prevent any boot deformation.

Boot installation length "L" : 148.7 mm (5.85 in)

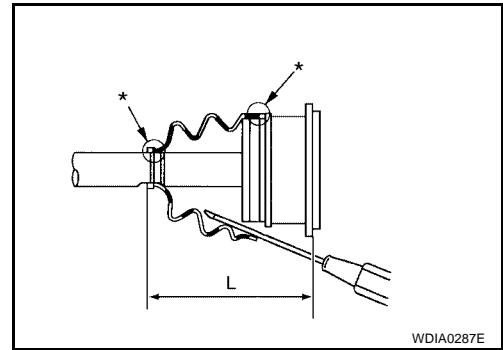

CAUTION:

- The boot may break if the boot installation length is less than the specified value.
- Do not touch the tip of the screwdriver to the inside of the boot.

10. Secure the large and small ends of the boot with the new boot bands as shown.

NOTE:

Discard the old boot bands and use new ones for assembly.

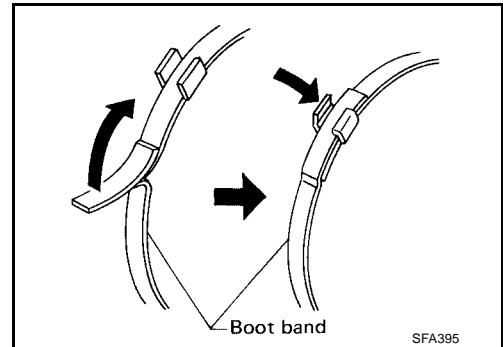

11. After installing the housing and shaft, rotate the boot to check that the boot is positioned correctly. If the boot is not positioned correctly, reposition the boot and secure the boot using a new boot band.

Wheel Side

1. Insert the Genuine NISSAN Grease or equivalent, into the joint sub-assembly serration hole until the grease begins to ooze from the ball groove and serration hole. Refer to [MA-11, "Fluids and Lubricants"](#) . After inserting the grease, use a shop cloth to wipe off the grease that has oozed out.

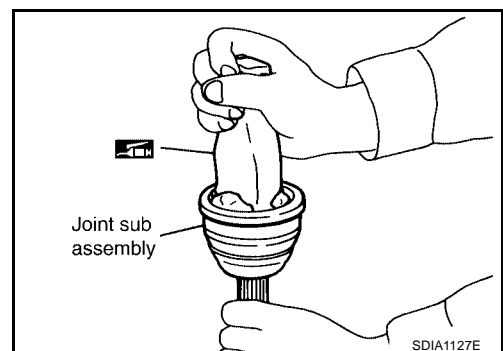

A
B
C
RAX
E
F
G
H
I
J
K
L
M

REAR DRIVE SHAFT

2. Wind the serrated part of the shaft with tape. Install the boot band and boot onto the shaft. Do not damage the boot.

NOTE:

Discard the old boot band and boot and use a new one for assembly.

3. Remove the protective tape wound around the serrated part of the shaft.

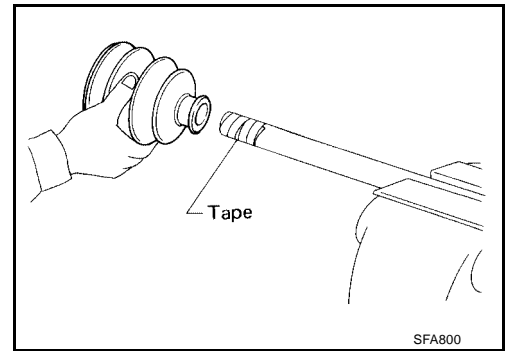

4. Attach the circlip to the shaft. The circlip must fit securely into the shaft groove. Attach the nut to the joint sub-assembly. Use a soft hammer to press-fit the circlip.

NOTE:

Discard the old circlip and use a new one for assembly.

5. Insert the specified quantity of Genuine NISSAN Grease or equivalent, into the housing from the large end of the boot. Refer to [MA-11, "Fluids and Lubricants"](#).

Grease capacity : 155 – 175 g (5.47 – 6.17 oz)

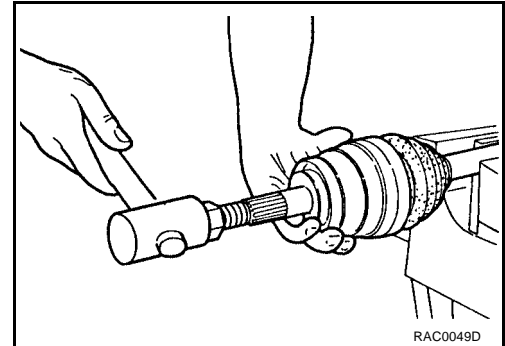

6. Install the boot securely into the grooves (indicated by the * marks) as shown.

CAUTION:

If there is grease on the boot mounting surfaces (indicated by the * marks) of the shaft and housing, the boot may come off. Remove all grease from the shaft surfaces.

7. Check that the boot installation length "L" is the specified length. Insert a flat-bladed screwdriver or similar tool into the larger side of the boot. Bleed the air from the boot to prevent boot deformation.

Boot installation length "L" : 143 mm (5.63 in)

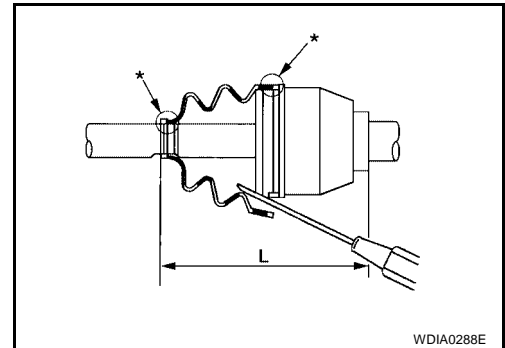

CAUTION:

- The boot may break if the boot installation length is less than the specified length.
- Do not contact inside surface of boot with the tip of the screwdriver.

8. Secure the large and small ends of the boot using new boot bands as shown.

NOTE:

Discard the old boot bands and use new ones for assembly.

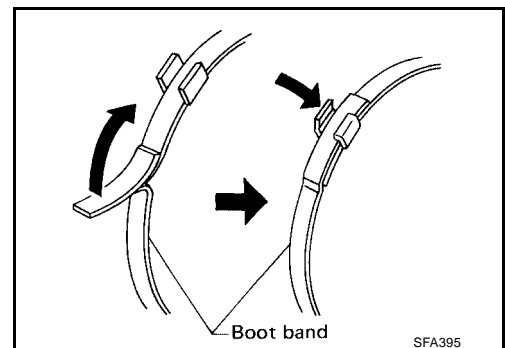

9. After installing the joint sub-assembly and shaft, rotate the boot to check that it is positioned correctly. If the boot is not positioned correctly, reposition the boot and secure the boot using a new boot band.

SERVICE DATA AND SPECIFICATIONS (SDS)

SERVICE DATA AND SPECIFICATIONS (SDS)

PF000030

Wheel Bearing

EDS003AR

Measurement of spring scale	Less than 26.6 N (2.7 kg, 5.95 lb)
Axial end play	0 mm (0 in)

Drive Shaft

EDS003AS

Joint	Wheel side	Final drive side
Grease capacity	155 – 175 g (5.47 – 6.17 oz)	155 – 175 g (5.47 – 6.17 oz)
Boot installed length	143 mm (5.63 in)	148.7 mm (5.85 in)

A
B
C
RAX
E
F
G
H
I
J
K
L
M

SERVICE DATA AND SPECIFICATIONS (SDS)
