

A
B
C

WW

SECTION

WIPER, WASHER & HORN

CONTENTS

<p>PRECAUTION 3</p> <p>Precautions for Supplemental Restraint System (SRS) "AIR BAG" and "SEAT BELT PRE-TENSIONER" 3</p> <p>FRONT WIPER AND WASHER SYSTEM 4</p> <p>Components Parts and Harness Connector Location 4</p> <p>System Description 4</p> <p> LOW SPEED WIPER OPERATION 5</p> <p> HI SPEED WIPER OPERATION 5</p> <p> INTERMITTENT OPERATION 5</p> <p> AUTO STOP OPERATION 5</p> <p> FRONT WASHER OPERATION 6</p> <p> MIST OPERATION 6</p> <p> FAIL-SAFE FUNCTION 6</p> <p> COMBINATION SWITCH READING FUNCTION... 6</p> <p>CAN Communication System Description 6</p> <p>Schematic 7</p> <p>Wiring Diagram — WIPER — 8</p> <p>Terminals and Reference Values for BCM 11</p> <p>Terminals and Reference Values for IPDM E/R 11</p> <p>Work Flow 11</p> <p>Preliminary Inspection 11</p> <p>CONSULT-II Function (BCM) 11</p> <p> CONSULT-II OPERATION 11</p> <p> WORK SUPPORT 12</p> <p> DATA MONITOR 13</p> <p> ACTIVE TEST 13</p> <p>CONSULT-II Function (IPDM E/R) 13</p> <p> CONSULT-II OPERATION 14</p> <p> DATA MONITOR 14</p> <p> ACTIVE TEST 15</p> <p>Trouble Diagnosis 15</p> <p> FRONT WIPER DOES NOT OPERATE 15</p> <p> FRONT WIPER STOP POSITION IS INCORRECT 19</p> <p> ONLY FRONT WIPER LOW DOES NOT OPERATE 20</p> <p> ONLY FRONT WIPER HI DOES NOT OPERATE. 22</p> <p> ONLY FRONT WIPER INT DOES NOT OPERATE</p>	<p> ATE 23</p> <p> FRONT WIPER INTERMITTENT OPERATION SWITCH POSITION CANNOT BE ADJUSTED... 24</p> <p> WIPERS DO NOT WIPE WHEN FRONT WASHER OPERATES 24</p> <p> FRONT WIPERS OPERATE FOR 10 SECONDS, STOP FOR 20 SECONDS, AND AFTER REPEATING THIS OPERATION FIVE TIMES, THEY BECOME INOPERATIVE 24</p> <p>Removal and Installation 26</p> <p> FRONT WIPER ARMS 26</p> <p> WIPER MOTOR AND LINKAGE 27</p> <p> WASHER HOSE LAYOUT 28</p> <p> WASHER NOZZLES 28</p> <p> WIPER AND WASHER SWITCH 28</p> <p> WASHER FLUID RESERVOIR 29</p> <p> WASHER MOTOR 30</p> <p> WASHER FLUID LEVEL SENSOR 30</p> <p> Washer Nozzle Adjustment 30</p> <p>REAR WIPER AND WASHER SYSTEM 31</p> <p>Components Parts and Harness Connector Location 31</p> <p>System Description 31</p> <p> REAR WIPER OPERATION 31</p> <p> INTERMITTENT OPERATION 32</p> <p> AUTO STOP OPERATION 32</p> <p> REAR WASHER OPERATION 32</p> <p> BCM WIPER SWITCH READING FUNCTION ... 32</p> <p>Wiring Diagram — WIP/R — 33</p> <p>Terminals and Reference Values for BCM 35</p> <p>How to Proceed With Trouble Diagnosis 35</p> <p>Preliminary Check 35</p> <p>CONSULT-II Function (BCM) 35</p> <p> CONSULT-II OPERATION 35</p> <p> DATA MONITOR 36</p> <p> ACTIVE TEST 37</p> <p>Rear Wiper Does Not Operate 37</p> <p>Rear Wiper Stop Position Is Incorrect 39</p> <p>Only Rear Wiper Does Not Operate 41</p> <p>Only Rear Wiper Intermittent Does Not Operate ... 41</p>
----------------------------------------------------------------------------------------------------------------------------------------------------------------------------------------------------------------------------------------------------------------------------------------------------------------------------------------------------------------------------------------------------------------------------------------------------------------------------------------------------------------------------------------------------------------------------------------------------------------------------------------------------------------------------------------------------------------------------------------------------------------------------------------------------------------------------------------------------------------------------------------------------------------------------------------------------------------------------------------------------------------------------------------------------------------------------------------------------------------------------------------------------------------------------------------------------------------------------------------------------------------------------------------------------------------------------------------------------------------------------------------------------------------------------------------------------------------------------------------------------------------------------------------------------------------------------------------------------------------------	----------------------------------------------------------------------------------------------------------------------------------------------------------------------------------------------------------------------------------------------------------------------------------------------------------------------------------------------------------------------------------------------------------------------------------------------------------------------------------------------------------------------------------------------------------------------------------------------------------------------------------------------------------------------------------------------------------------------------------------------------------------------------------------------------------------------------------------------------------------------------------------------------------------------------------------------------------------------------------------------------------------------------------------------------------------------------------------------------------------------------------------------------------------------------------------------------------------------------------------------------------------------------------------------------------------------------------------------------------------------------------------------------------------------------------------------------------------------------------------------------------------------------------------------------------------------------------------------------------------------------------------------------------------------------------------------------------

A
B
C
D
E
F
G
H
I
J
K
L
M

WW

Wiper Does Not Wipe When Rear Washer Operates..	41	Wiring Diagram — P/SCKT —	46
Removal and Installation	42	Removal and Installation	47
REAR WIPER ARM	42	LOWER FRONT POWER SOCKET AND REAR	
REAR WIPER MOTOR	43	CARGO POWER SOCKET	47
REAR WASHER TUBE LAYOUT	44	UPPER FRONT POWER SOCKET (FOR CIG-	
REAR WASHER NOZZLE	44	ARETTE LIGHTER) AND CONSOLE POWER	
WASHER FLUID RESERVOIR	45	SOCKET	47
WIPER AND WASHER SWITCH	45	HORN	48
WASHER MOTOR	45	Wiring Diagram — HORN —	48
Rear Washer Nozzle Adjustment	45	Removal and Installation	49
POWER SOCKET	46	REMOVAL	49
		INSTALLATION	49

PRECAUTION

PRECAUTION

PF0:00011

Precautions for Supplemental Restraint System (SRS) “AIR BAG” and “SEAT BELT PRE-TENSIONER”

EKS00FZA

The Supplemental Restraint System such as “AIR BAG” and “SEAT BELT PRE-TENSIONER”, used along with a front seat belt, helps to reduce the risk or severity of injury to the driver and front passenger for certain types of collision. This system includes seat belt switch inputs and dual stage front air bag modules. The SRS system uses the seat belt switches to determine the front air bag deployment, and may only deploy one front air bag, depending on the severity of a collision and whether the front occupants are belted or unbelted. Information necessary to service the system safely is included in the SRS and SB section of this Service Manual.

WARNING:

- To avoid rendering the SRS inoperative, which could increase the risk of personal injury or death in the event of a collision which would result in air bag inflation, all maintenance must be performed by an authorized NISSAN/INFINITI dealer.
- Improper maintenance, including incorrect removal and installation of the SRS, can lead to personal injury caused by unintentional activation of the system. For removal of Spiral Cable and Air Bag Module, see the SRS section.
- Do not use electrical test equipment on any circuit related to the SRS unless instructed to in this Service Manual. SRS wiring harnesses can be identified by yellow and/or orange harnesses or harness connectors.

A

B

C

D

E

F

G

H

I

J

WW

L

M

FRONT WIPER AND WASHER SYSTEM

FRONT WIPER AND WASHER SYSTEM

PF2:28810

Components Parts and Harness Connector Location

EKS00FZC

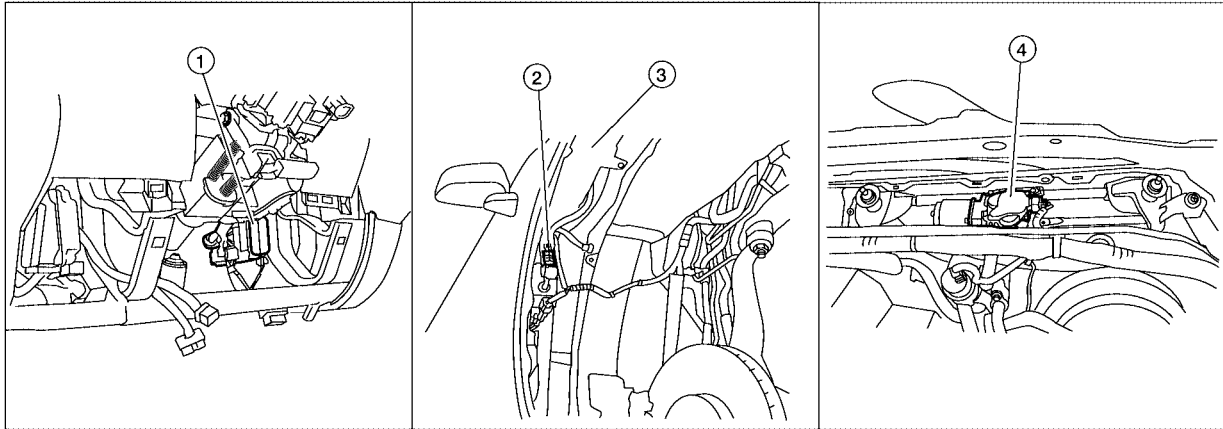

WKIA4896E

1. BCM
M18, M19, M20
(view with instrument lower panel LH removed)
2. Front and rear washer motor connector
E105
(view with right front fender protector removed)
3. Washer fluid reservoir
4. Front wiper motor
E23

System Description

EKS00FZD

- Both front wiper relays are located in the IPDM E/R (intelligent power distribution module engine room).
- The wiper switch (combination switch) is composed of a combination of 5 output terminals and 5 input terminals. Terminal combination status is read by the BCM (body control module) when the wiper switch is turned ON.
- BCM controls front wiper LO, HI, and INT (intermittent) operation.
- IPDM E/R operates the wiper motor according to CAN communication signals from the BCM.

Power is supplied at all times

- to ignition relay, located in the IPDM E/R, and
- through 50A fusible link (letter **g**, located in the fuse and fusible link box)
- to BCM terminal 70, and
- through 30A fuse (No. 39, located in the IPDM E/R)
- to front wiper relay (located in the IPDM E/R).

With the ignition switch in ON or START position, power is supplied

- through 10A fuse [No. 15, located in the fuse block (J/B)]
- to combination switch terminal 2, and
- through 10A fuse [No. 1, located in the fuse block (J/B)]
- to BCM terminal 38.

Ground is supplied

- to BCM terminal 67 and
- to combination switch terminal 9
- through grounds M57, M61 and M79, and
- to IPDM E/R terminals 38 and 59 and
- to front wiper motor terminal 2
- through grounds E9, E15 and E24.

FRONT WIPER AND WASHER SYSTEM

LOW SPEED WIPER OPERATION

When the ignition switch is in the ON or START position, and the front wiper switch is turned to the low position, the BCM detects a low speed wiper ON request through the combination switch (wiper switch) reading function.

The BCM then sends a front wiper (low) request signal over CAN communication lines

- from BCM terminals 39 and 40
- to IPDM E/R terminals 39 and 40.

When IPDM E/R receives front wiper (low) request signal, it supplies ground to energize the front wiper relay. With the front wiper relay energized, power is supplied

- through front wiper relay
- to front wiper high relay
- through IPDM E/R terminal 32
- to front wiper motor terminal 1.

With power and ground supplied, the front wiper motor operates at low speed.

HI SPEED WIPER OPERATION

When the ignition switch is in the ON or START position, and the front wiper switch is turned to the high position, the BCM detects a high speed wiper ON request through the combination switch (wiper switch) reading function.

The BCM then sends a front wiper (high) request signal over CAN communication lines

- from BCM terminals 39 and 40
- to IPDM E/R terminals 39 and 40.

When the IPDM E/R receives a front wiper (high) request signal, it supplies ground to energize the front wiper and the front wiper high relays.

With the front wiper and the front wiper high relays energized, power is supplied

- through front wiper relay
- to front wiper high relay
- through IPDM E/R terminal 35
- to front wiper motor terminal 4.

With power and ground supplied, the front wiper motor operates at high speed.

INTERMITTENT OPERATION

Wiper intermittent operation delay interval is determined from the combination of the intermittent wiper dial position inputs and vehicle speed. During each intermittent operation delay interval, the BCM sends a front wiper request signal to the IPDM E/R to operate the wipers.

When the ignition switch is in the ON or START position, and the front wiper switch is turned to an intermittent position, the BCM detects a front wiper (intermittent) ON request through the combination switch (wiper switch) reading function.

The BCM then sends a front wiper (intermittent) request signal over CAN communication lines

- from BCM terminals 39 and 40
- to IPDM E/R terminals 39 and 40.

When the BCM determines that combination switch status is front wiper intermittent ON, it performs the following operations.

- BCM detects ON/OFF status of intermittent wiper dial position.
- BCM calculates operation interval from wiper dial position and vehicle speed signal received through CAN communications.
- BCM sends front wiper request signal (INT) to IPDM E/R at calculated operation interval.

When the IPDM E/R receives a front wiper request signal (INT), it supplies ground to energize the front wiper relay. It then sends an auto-stop signal to the BCM, and conducts intermittent front wiper motor operation.

AUTO STOP OPERATION

When the wiper arms are not located at the base of the windshield, and the wiper switch is turned OFF, the wiper motor will continue to operate until the wiper arms reach the windshield base. When the wiper arms reach the base of windshield, front wiper motor terminals 5 and 2 are connected.

Ground is supplied

A
B
C
D
E
F
G
H
I
J
L
M

WW

FRONT WIPER AND WASHER SYSTEM

- to IPDM E/R terminal 43
- through front wiper motor terminal 5
- through front wiper motor terminal 2
- through grounds E9, E15 and E24.

The IPDM E/R sends an auto stop operation signal to the BCM through CAN communication lines. When the BCM receives an auto stop operation signal, the BCM sends wiper stop signal to the IPDM E/R over CAN communication lines. The IPDM E/R then de-energizes the front wiper relay. The wiper motor will then stop the wiper arms at the STOP position.

FRONT WASHER OPERATION

When the ignition switch is in the ON or START position, and the front and rear washer switches are OFF, the front and rear washer motor is supplied power

- through 10A fuse [No. 15, located in the fuse block (J/B)]
- through combination switch (wiper switch) terminal 2
- through combination switch (wiper switch) terminal 4
- to front and rear washer motor terminal 1.

When the front wiper switch is in the front washer position, the BCM detects a front washer signal request through the combination switch (wiper switch) reading function.

Combination switch ground is supplied

- to front and rear washer motor terminal 2
- through combination switch (wiper switch) terminal 3
- through combination switch (wiper switch) terminal 9
- through grounds M57, M61 and M79.

With ground supplied, the front and rear washer motor is operated in the front direction.

When the BCM detects that front washer motor has operated for 0.4 seconds or longer, the BCM uses CAN communication and sends a wiper request signal to the IPDM E/R for low speed operation of wipers.

When the BCM detects that the washer switch is OFF, low speed operation cycles approximately 3 times and then stops.

MIST OPERATION

When the wiper switch is temporarily placed in the mist position, wiper low speed operation cycles once and then stops.

For additional information about wiper operation under this condition, refer to [WW-5, "LOW SPEED WIPER OPERATION"](#).

If the switch is held in the mist position, low speed operation continues.

FAIL-SAFE FUNCTION

The BCM includes fail-safe function to prevent malfunction of electrical components controlled by CAN communications if a malfunction in CAN communications occurs.

The BCM uses CAN communications to stop output of electrical components it controls.

Until the ignition switch is turned OFF, the front wiper system remains in same status as just before fail-safe control was initiated. (If wiper was in low speed operation just before fail-safe, it continues low speed operation until ignition switch is turned OFF.)

When fail-safe status is initiated, the BCM remains in standby until normal signals are received.

When normal signals are received, fail-safe status is canceled.

COMBINATION SWITCH READING FUNCTION

Refer to [BCS-3, "COMBINATION SWITCH READING FUNCTION"](#).

CAN Communication System Description

Refer to [LAN-25, "CAN COMMUNICATION"](#).

EKS00FZE

FRONT WIPER AND WASHER SYSTEM

Schematic

EKS00FZF

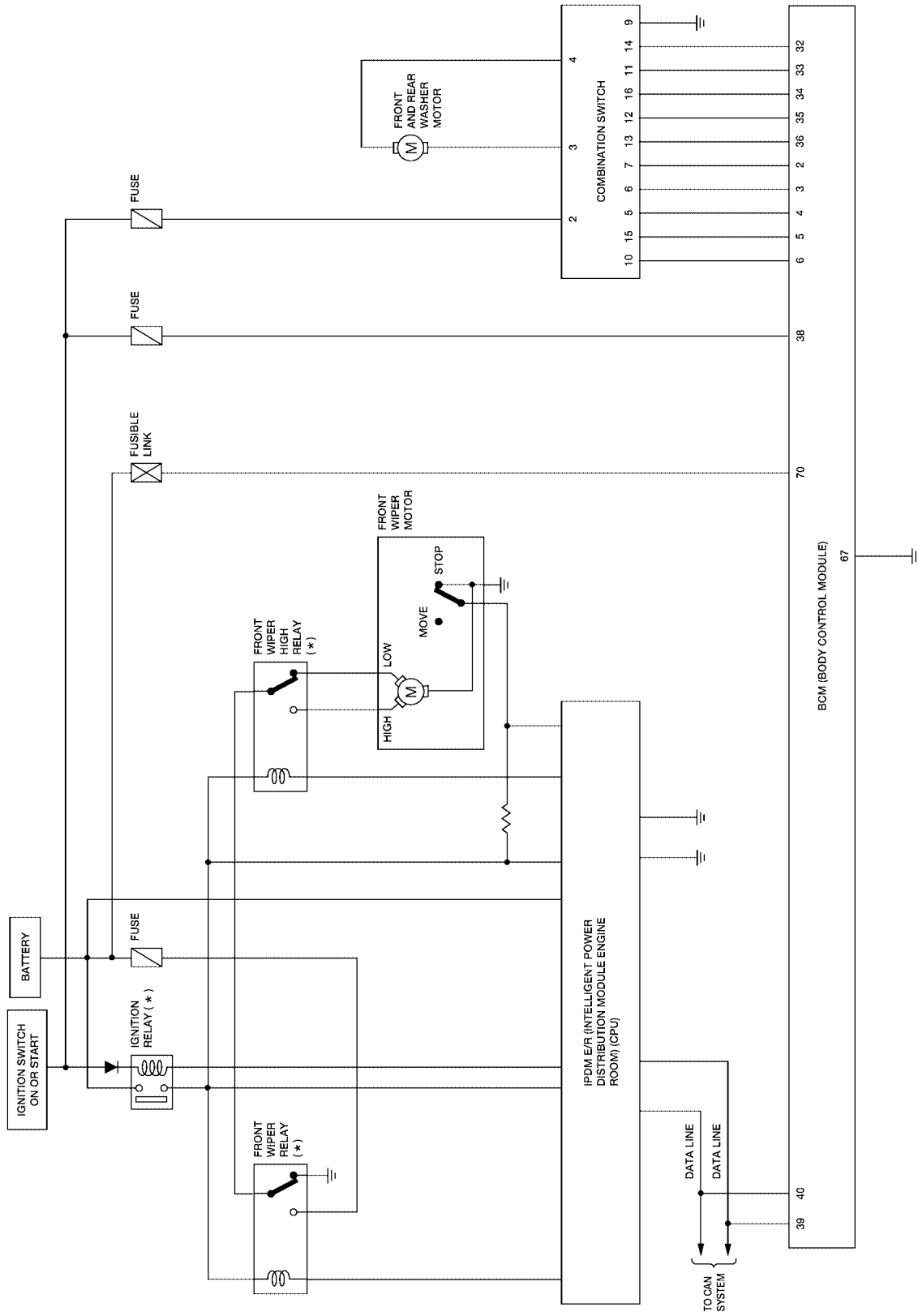

*: THIS RELAY IS BUILT INTO THE IPDM E/R (INTELLIGENT POWER DISTRIBUTION MODULE ENGINE ROOM)

A
B
C
D
E
F
G
H
I
J
L
M

WW

WKWA2985E

FRONT WIPER AND WASHER SYSTEM

Wiring Diagram — WIPER —

EKS00FZG

WW-WIPER-01

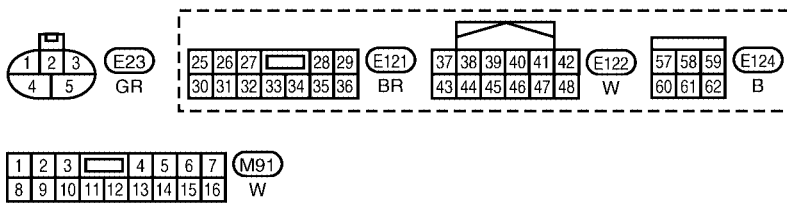
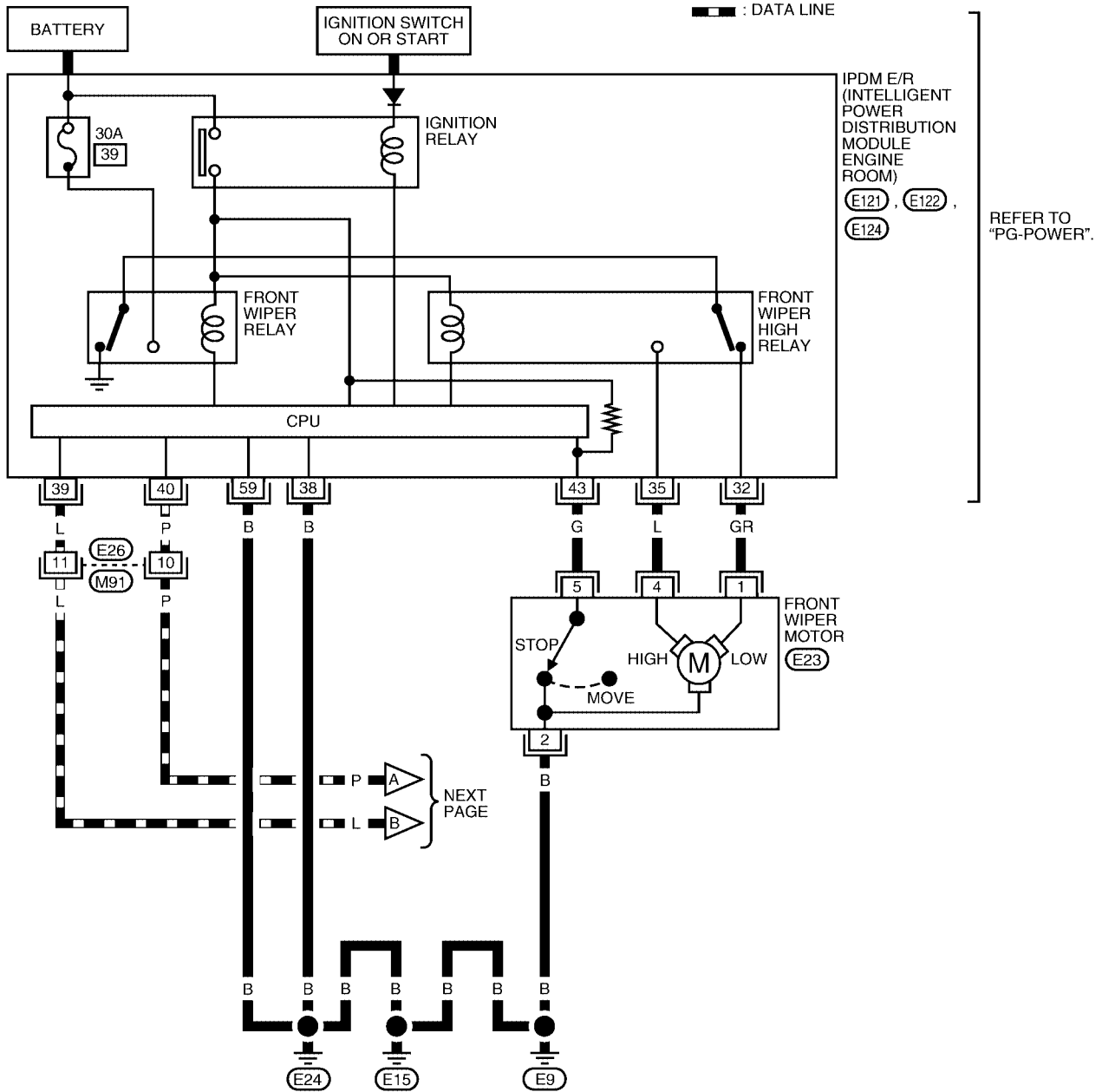

WKWA2986E

FRONT WIPER AND WASHER SYSTEM

WW-WIPER-02

▬ : DATA LINE

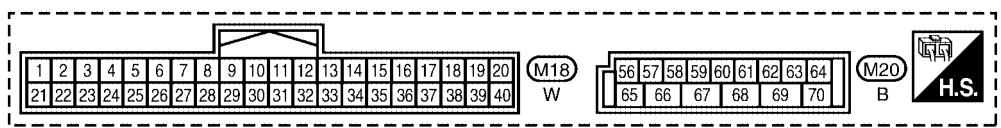
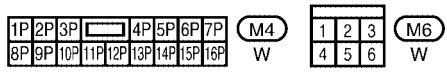
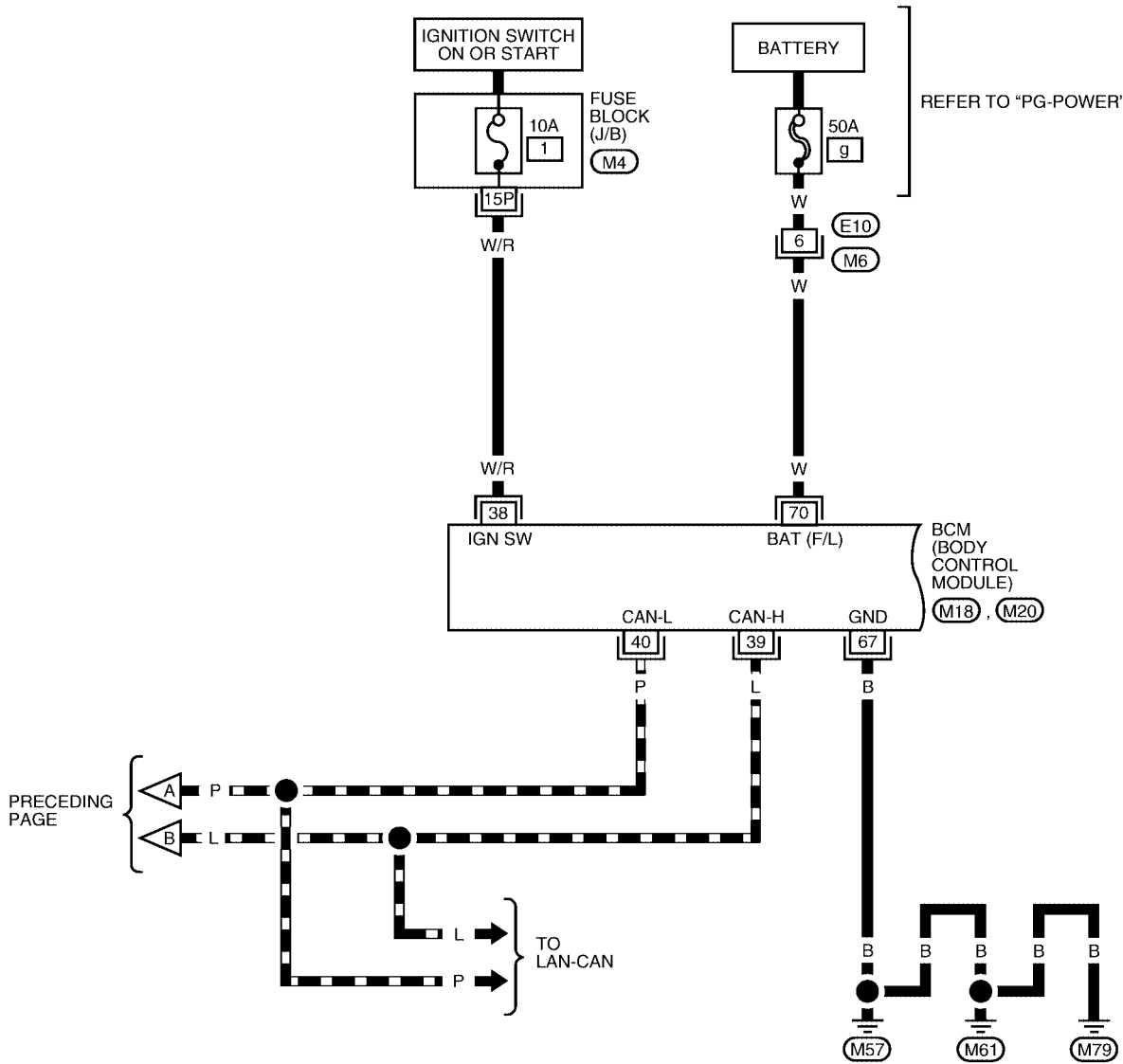

WKWA2987E

FRONT WIPER AND WASHER SYSTEM

WW-WIPER-03

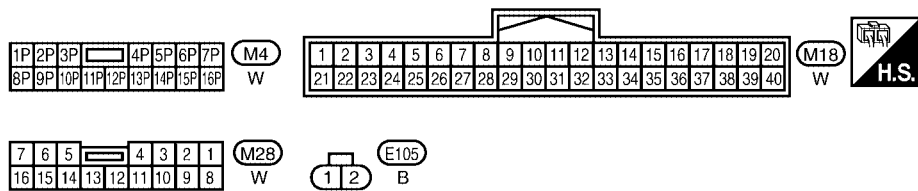
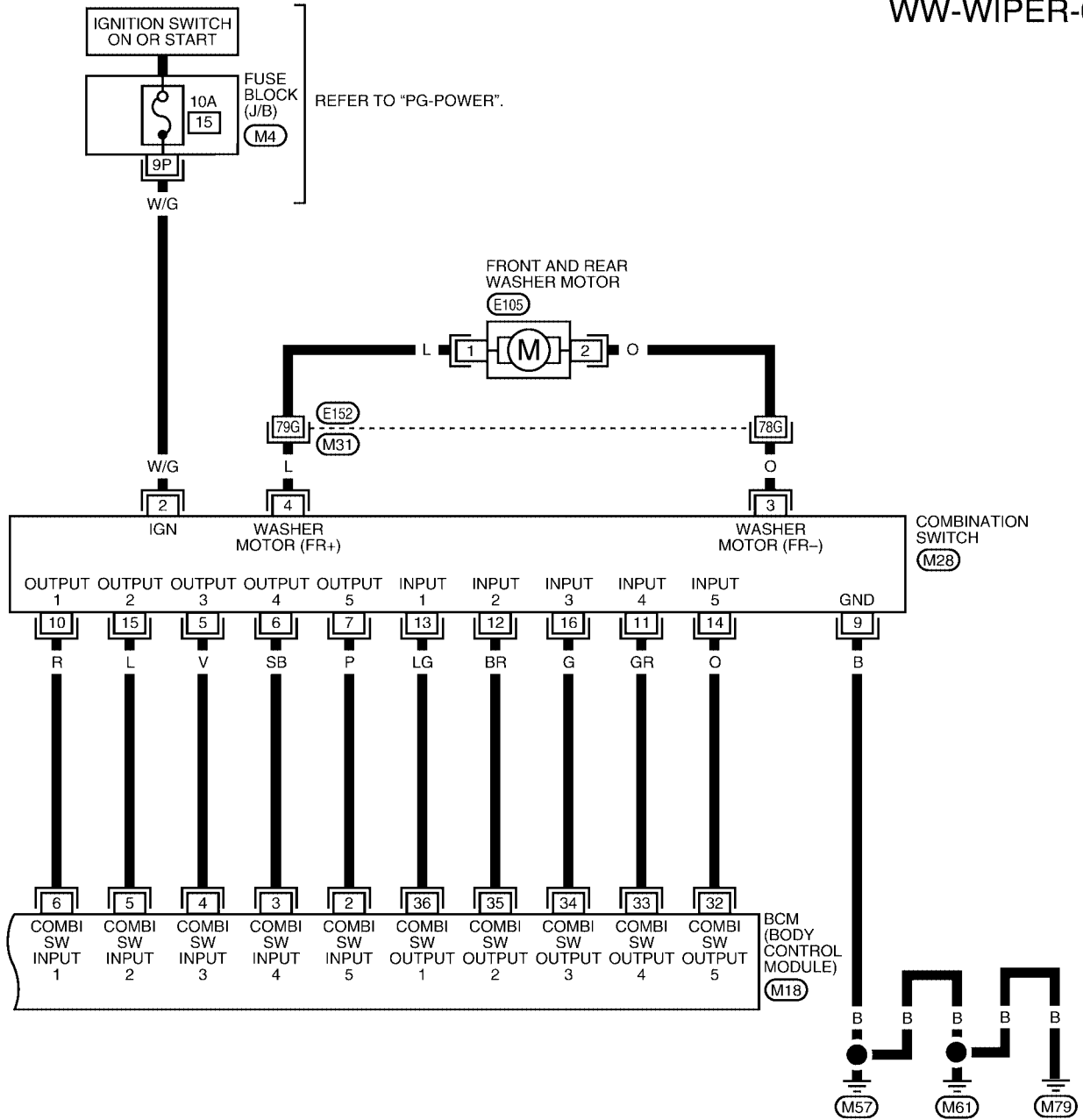

REFER TO THE FOLLOWING.
M31 - SUPER MULTIPLE JUNCTION (SMJ)

WKWA1966E

FRONT WIPER AND WASHER SYSTEM

Terminals and Reference Values for BCM

EKS00FZH

Refer to [BCS-12, "Terminals and Reference Values for BCM"](#) .

Terminals and Reference Values for IPDM E/R

EKS00FZI

Refer to [PG-28, "Terminals and Reference Values for IPDM E/R"](#) .

Work Flow

EKS00FZJ

1. Confirm the symptom or customer complaint.
2. Understand the system description, refer to [WW-4, "System Description"](#) .
3. Perform preliminary inspection, refer to [WW-11, "Preliminary Inspection"](#) .
4. Check symptom and repair or replace the cause of malfunction.
5. Does wiper function operate normally? If it operates normally, GO TO 6. If not, GO TO 4.
6. Inspection End.

Preliminary Inspection

EKS00FZK

Refer to [BCS-16, "BCM Power Supply and Ground Circuit Check"](#) .

CONSULT-II Function (BCM)

EKS00FZL

CONSULT-II can display each diagnostic item using the diagnostic test modes shown following.

BCM diagnostic test item	Diagnostic mode	Description
Inspection by part	WORK SUPPORT	Supports inspections and adjustments. Commands are transmitted to the BCM for setting the status suitable for required operation, input/output signals are received from the BCM and received data is displayed.
	DATA MONITOR	Displays BCM input/output data in real time.
	ACTIVE TEST	Operation of electrical loads can be checked by sending drive signal to them.
	SELF-DIAG RESULTS	Displays BCM self-diagnosis results.
	CAN DIAG SUPPORT MNTR	The result of transmit/receive diagnosis of CAN communication can be read.
	ECU PART NUMBER	BCM part number can be read.
	CONFIGURATION	Performs BCM configuration read/write functions.

CONSULT-II OPERATION

CAUTION:

If CONSULT-II is used with no connection of CONSULT-II CONVERTER, malfunctions might be detected in self-diagnosis depending on control unit which carries out CAN communication.

1. With the ignition switch OFF, connect CONSULT-II and CONSULT-II CONVERTER to the data link connector, then turn the ignition switch ON.

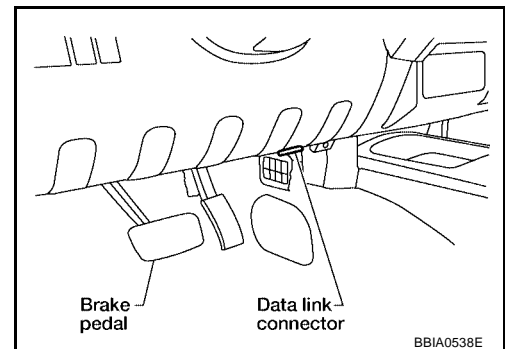

FRONT WIPER AND WASHER SYSTEM

2. Touch "START (NISSAN BASED VHCL)".

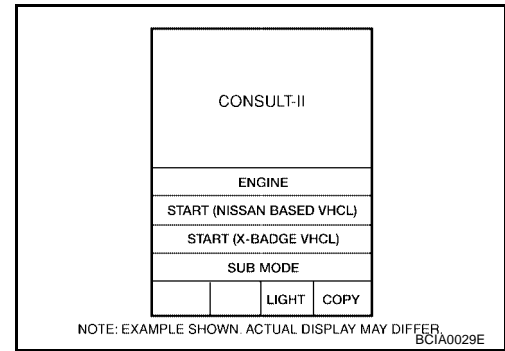

3. Touch "BCM" on the "SELECT SYSTEM" screen.
If "BCM" is not indicated, go to [GI-40, "CONSULT-II Data Link Connector \(DLC\) Circuit"](#).

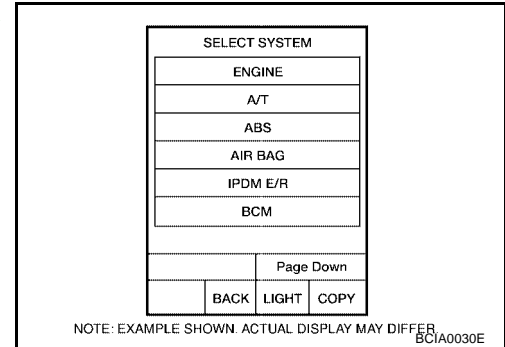

4. Select the desired part to be diagnosed on the "SELECT TEST ITEM" screen.

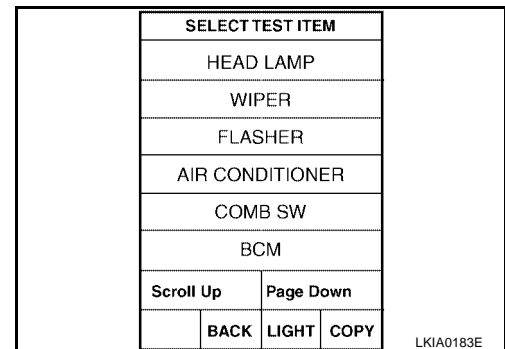

WORK SUPPORT

Operation Procedure

1. Touch "WIPER" on the "SELECT TEST ITEM" screen.
2. Touch "WORK SUPPORT" on the "SELECT DIAG MODE" screen.
3. Touch "WIPER SPEED SETTING" on the "SELECT WORK ITEM" screen.
4. Touch "START".
5. Touch "CHANGE SETT".
6. The setting will be changed and "CURRENT SETTING" will be displayed.
7. Touch "END".

Work Support Setting Item

Item	Description	CONSULT-II
WIPER SPEED SETTING	When wiper switch is at INTERMITTENT, front wiper intermittent time can be selected according to vehicle speed. ● ON (Operated)/OFF ^{NOTE} (Not operated)	ON/OFF

NOTE:

Factory setting

FRONT WIPER AND WASHER SYSTEM

DATA MONITOR

Operation Procedure

1. Touch "WIPER" on the "SELECT TEST ITEM" screen.
2. Touch "DATA MONITOR" on the "SELECT DIAG MODE" screen.
3. Touch either "ALL SIGNALS" or "SELECTION FROM MENU" on the "SELECT MONITOR ITEM" screen.

ALL SIGNALS	Monitors all the items.
SELECTION FROM MENU	Selects and monitors the individual item selected.

4. Touch "START".
5. When "SELECTION FROM MENU" is selected, touch items to be monitored. When "ALL SIGNALS" is selected, all the items will be monitored.
6. Touch "RECORD" while monitoring to record the status of the item being monitored. To stop recording, touch "STOP".

Display Item List

Monitor item name "OPERATION OR UNIT"	Contents
IGN ON SW "ON/OFF"	Displays "IGN Position (ON)/OFF, ACC Position (OFF)" status as judged from ignition switch signal.
IGN SW CAN "ON/OFF"	Displays "IGN switch ON (ON)/Other OFF or ACC (OFF)" status as judged from CAN communications.
FR WIPER HI "ON/OFF"	Displays "Front Wiper HI (ON)/Other (OFF)" status as judged from wiper switch signal.
FR WIPER LOW "ON/OFF"	Displays "Front Wiper LOW (ON)/Other (OFF)" status as judged from wiper switch signal.
FR WIPER INT "ON/OFF"	Displays "Front Wiper INT (ON)/Other (OFF)" status as judged from wiper switch signal.
FR WASHER SW "ON/OFF"	Displays "Front Washer Switch (ON)/Other (OFF)" status as judged from wiper switch signal.
INT VOLUME (1 - 7)	Displays intermittent operation dial position setting (1 - 7) as judged from wiper switch signal.
FR WIPER STOP "ON/OFF"	Displays "Stopped (ON)/Operating (OFF)" status as judged from the auto stop signal.
VEHICLE SPEED "0.0 km/h"	Displays vehicle speed as received from CAN communication.

ACTIVE TEST

Operation Procedure

1. Touch "WIPER" on the "SELECT TEST ITEM" screen.
2. Touch "ACTIVE TEST" on the "SELECT DIAG MODE" screen.
3. Touch item(s) to be tested and check operation of the selected item(s).
4. During the operation check, touching "BACK" deactivates the operation.

Display Item List

Test item	Display on CONSULT-II screen	Description
Front wiper HI output	FR WIPER (HI)	Front wiper HI can be operated by any ON-OFF operation.
Front wiper LO output	FR WIPER (LO)	Front wiper LO can be operated by any ON-OFF operation.
Front wiper INT output	FR WIPER (INT)	Front wiper INT can be operated by any ON-OFF operation.

CONSULT-II Function (IPDM E/R)

EKS00FZM

CONSULT-II can display each diagnostic item using the diagnostic test modes shown following.

IPDM E/R diagnostic Mode	Description
SELF-DIAG RESULTS	Displays IPDM E/R self-diagnosis results.
DATA MONITOR	Displays IPDM E/R input/output data in real time.
CAN DIAG SUPPORT MNTR	The result of transmit/receive diagnosis of CAN communication can be read.
ACTIVE TEST	Operation of electrical loads can be checked by sending drive signal to them.

FRONT WIPER AND WASHER SYSTEM

CONSULT-II OPERATION

CAUTION:

If CONSULT-II is used with no connection of CONSULT-II CONVERTER, malfunctions might be detected in self-diagnosis depending on control unit which carries out CAN communication.

1. With the ignition switch OFF, connect CONSULT-II and CONSULT-II CONVERTER to the data link connector, then turn the ignition switch ON.

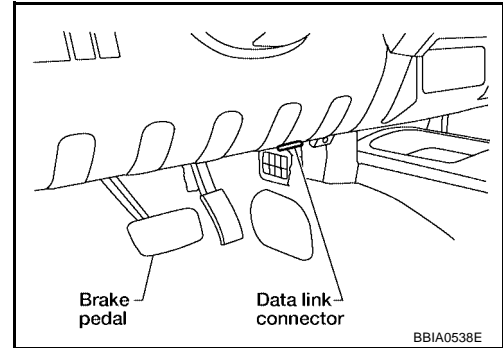

2. Touch "START (NISSAN BASED VHCL)".

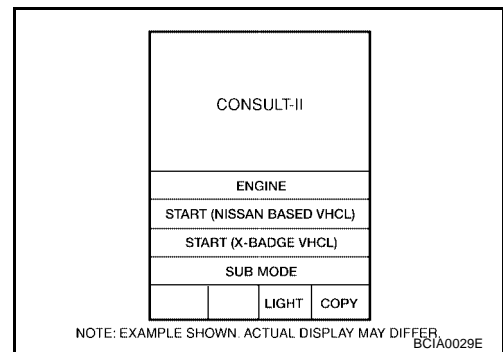

3. Touch "IPDM E/R" on "SELECT SYSTEM" screen.
If "IPDM E/R" is not displayed, go to [GI-40, "CONSULT-II Data Link Connector \(DLC\) Circuit"](#).

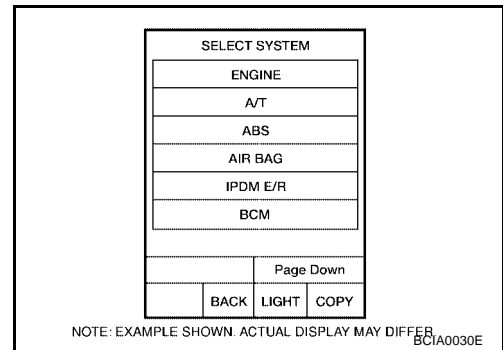

4. Select the desired part to be diagnosed on the "SELECT DIAG MODE" screen.

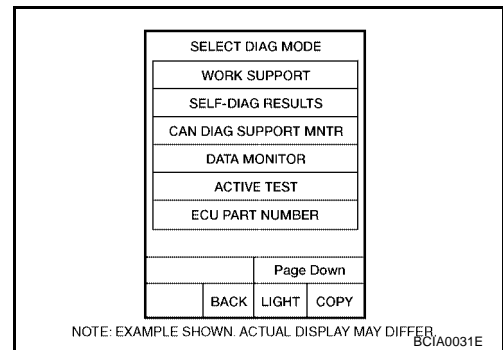

DATA MONITOR

Operation Procedure

1. Touch "WIPER" on the "SELECT TEST ITEM" screen.
2. Touch "DATA MONITOR" on the "SELECT DIAG MODE" screen.
3. Touch "ALL SIGNALS", "MAIN SIGNALS" or "SELECTION FROM MENU" on the "SELECT MONITOR ITEM" screen.

FRONT WIPER AND WASHER SYSTEM

ALL SIGNALS	Monitors all the items.
MAIN SIGNALS	Monitors predetermined items.
SELECTION FROM MENU	Selects and monitors the individual item selected.

4. Touch "START".
5. When "SELECTION FROM MENU" is selected, touch items to be monitored. When "ALL SIGNALS" is selected, all the items will be monitored. When "MAIN SIGNALS" is selected, predetermined items are monitored.
6. Touch "RECORD" while monitoring to record the status of the item being monitored. To stop recording, touch "STOP".

All Items, Main Items, Select Item Menu

Item name	CONSULT-II screen display	Display or unit	Monitor item selection			Description
			ALL SIGNALS	MAIN SIGNALS	SELECTION FROM MENU	
Front wiper request	FR WIP REQ	STOP/1LO/LO/HI	x	x	x	Signal status input from BCM.
Wiper auto stop	WIP AUTO STOP	ACT P/STOP P	x	x	x	Output status of IPDM E/R.
Wiper protection	WIP PROT	OFF/LS/HS/BLOCK	x	x	x	Control status of IPDM E/R.

NOTE:

Perform monitoring of IPDM E/R data with the ignition switch ON. When the ignition switch is at ACC, the display may not be correct.

ACTIVE TEST

Operation Procedure

1. Touch "WIPER" on the "SELECT TEST ITEM" screen.
2. Touch "ACTIVE TEST" on the "SELECT DIAG MODE" screen.
3. Touch item(s) to be tested and check operation of the selected item(s).
4. During the operation check, touching "BACK" deactivates the operation.

Display Item List

Test item	CONSULT-II screen display	Description
Front wiper (HI, LO) output	FRONT WIPER	With a certain operation (OFF, HI, LO) front wiper relays can be operated.

Trouble Diagnosis

FRONT WIPER DOES NOT OPERATE

EKS00FZN

CAUTION:

During IPDM E/R fail-safe control, front wipers may not operate. Refer to [PG-18. "CAN COMMUNICATION LINE CONTROL"](#) to make sure that it is not in fail-safe status.

FRONT WIPER AND WASHER SYSTEM

Inspection Procedure

1. CHECK IPDM E/R TO FRONT WIPERS

Ⓟ With CONSULT-II

1. Select "IPDM E/R" with CONSULT-II, and select "ACTIVE TEST" on "SELECT DIAG MODE" screen.
2. Select "FRONT WIPER" on "SELECT TEST ITEM" screen.

ⓧ Without CONSULT-II

1. Turn on front wipers using auto active test. Refer to [PG-24, "Auto Active Test"](#).
2. Confirm front wiper operation.

OK or NG

- OK >> GO TO 4.
NG >> GO TO 2.

ACTIVE TEST			
FRONT WIPER		OFF	
HI		LO	
MODE	BACK	LIGHT	COPY

SKIA3486E

FRONT WIPER AND WASHER SYSTEM

2. IPDM E/R TO FRONT WIPERS CIRCUIT INSPECTION

1. Turn ignition switch OFF.
2. Disconnect IPDM E/R connectors and front wiper motor connector.
3. Check continuity between IPDM E/R harness connector terminals and front wiper motor harness connector terminals.

IPDM E/R		Front wiper motor		Continuity
Connector	Terminal	Connector	Terminal	
E121	32	E23	1	Yes
	35		4	
E122	43		5	

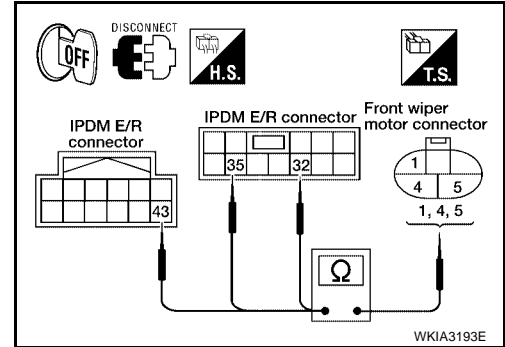

4. Check continuity between IPDM E/R harness connector terminals and ground.

IPDM E/R		Continuity	
Connector	Terminal		
E121	32	Ground	No
	35		
E122	43		

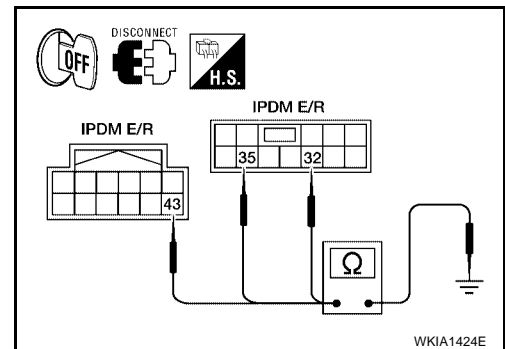

5. Check continuity between IPDM E/R harness connector terminal and ground.

IPDM E/R		Continuity	
Connector	Terminal		
E122	38	Ground	Yes
E124	59		

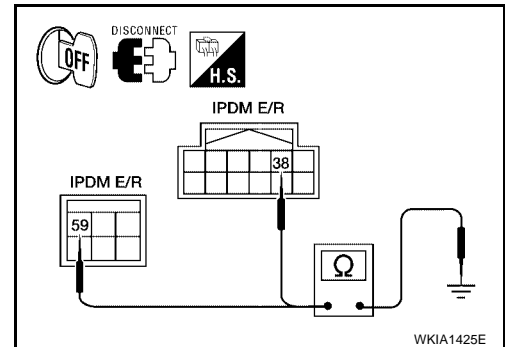

6. Check continuity between front wiper motor harness connector E23 terminal 2 and ground.

Front wiper motor		Continuity	
Connector	Terminal		
E23	2	Ground	Yes

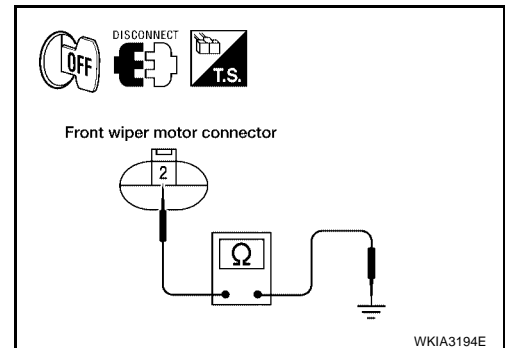

OK or NG

- OK >> Connect connectors. GO TO 3.
 NG >> Repair harness or connector.

FRONT WIPER AND WASHER SYSTEM

3. IPDM E/R INSPECTION

① With CONSULT-II

1. Select "IPDM E/R" with CONSULT-II, and select "ACTIVE TEST" on "SELECT DIAG MODE" screen.
2. Select "FRONT WIPER" on "SELECT TEST ITEM" screen.

⊗ Without CONSULT-II

1. Turn on front wipers using the auto active test. Refer to [PG-24, "Auto Active Test"](#).

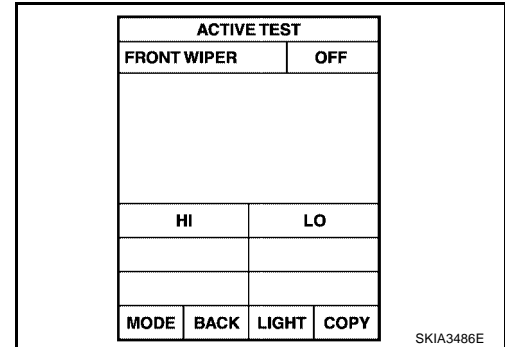

When front wiper relay, and front wiper high relay are operating, check voltage between IPDM E/R harness connector E121 terminals 32, 35 and ground.

IPDM E/R		(-)	Condition	Voltage (Approx.)
Connector	Terminal			
E121	32	Ground	Stopped	0
			LO operation	Battery voltage
	35		Stopped	0
			HI operation	Battery voltage

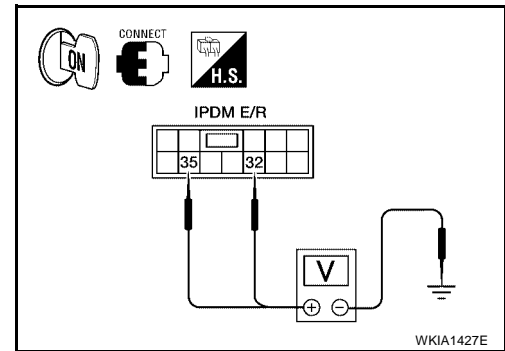

OK or NG

- OK >> Replace the front wiper motor. Refer to [WW-27, "WIPER MOTOR AND LINKAGE"](#).
- NG >> Replace IPDM E/R. Refer to [PG-32, "Removal and Installation of IPDM E/R"](#).

4. COMBINATION SWITCH TO BCM INSPECTION

Select "BCM" on CONSULT-II. With "WIPER" data monitor, check that "FR WIPER INT", "FR WIPER LOW" and "FR WIPER HI" turn ON-OFF according to operation of wiper switch.

OK or NG

- OK >> GO TO 5.
- NG >> Check wiper switch. Refer to [BCS-3, "COMBINATION SWITCH READING FUNCTION"](#).

5. BCM INSPECTION

Select "BCM" on CONSULT-II. Carry out self-diagnosis of BCM.

Displayed self-diagnosis results

- NO DTC>> Replace the BCM. Refer to [BCS-27, "Removal and Installation"](#).
- CAN COMM CIRCUIT>> Check CAN communication line of BCM. GO TO [BCS-20, "CAN Communication Inspection Using CONSULT-II \(Self-Diagnosis\)"](#).

FRONT WIPER AND WASHER SYSTEM

FRONT WIPER STOP POSITION IS INCORRECT

Inspection Procedure

1. CHECK IPDM E/R TO FRONT WIPER MOTOR

Ⓜ With CONSULT-II

Select "IPDM E/R" with CONSULT-II. With data monitor, confirm that "WIP AUTO STOP" changes from "ACT P" to "STOP P" according to wiper operation.

ⓧ Without CONSULT-II

GO TO 2.

OK or NG

OK >> Replace IPDM E/R. Refer to [PG-32, "Removal and Installation of IPDM E/R"](#).

NG >> GO TO 2.

DATA MONITOR	
MONITOR	
MOTOR FAN REQ	1
AC COMP REQ	OFF
TAIL&CLR REQ	OFF
HL LO REQ	OFF
HL HI REQ	OFF
FR FOG REQ	OFF
FR WIP REQ	STOP
WIP AUTO STOP	STOP P
WIP PROT	OFF
Page DOWN	
RECORD	
MODE	BACK
LIGHT	COPY

SKIA5301E

2. IPDM E/R TO FRONT WIPER MOTOR CIRCUIT INSPECTION

1. Turn ignition switch OFF.
2. Disconnect IPDM E/R connector and front wiper motor connector.
3. Check continuity between IPDM E/R harness connector E122 terminal 43 and front wiper motor harness connector E23 terminal 5.

IPDM E/R		Front wiper motor		Continuity
Connector	Terminal	Connector	Terminal	
E122	43	E23	5	Yes

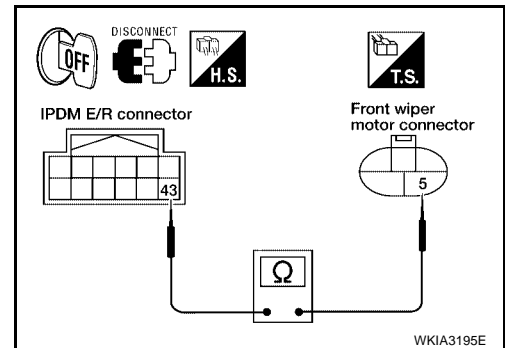

4. Check continuity between IPDM E/R harness connector E122 terminal 43 and ground.

IPDM E/R		Continuity
Connector	Terminal	
E122	43	Ground
		No

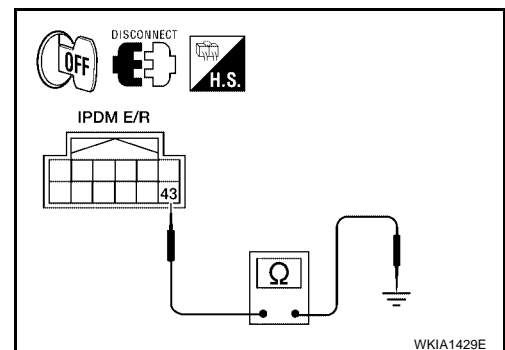

5. Check continuity between front wiper motor harness connector E23 terminal 2 and ground.

Front wiper motor		Continuity
Connector	Terminal	
E23	2	Ground
		Yes

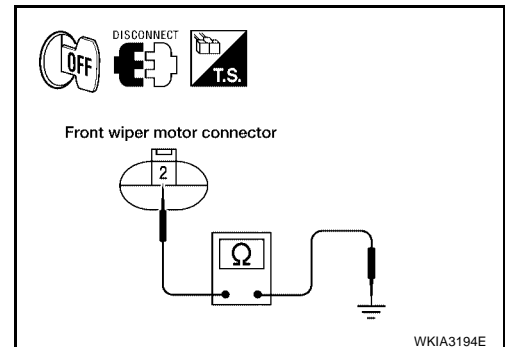

OK or NG

OK >> GO TO 3.

- NG >>
- Check for short circuit or open circuit in harness between IPDM E/R and front wiper motor.
 - Check for open circuit in harness between front wiper motor and ground.

A
B
C
D
E
F
G
H
I
J
L
M

WW

FRONT WIPER AND WASHER SYSTEM

3. IPDM E/R INSPECTION

☑ With CONSULT-II

1. Connect IPDM E/R connector and front wiper motor connector.
2. Select "LO" on "ACTIVE TEST" screen.

☒ Without CONSULT-II

1. Connect IPDM E/R connector and front wiper motor connector.
2. Turn on front wipers using the auto active test. Refer to [PG-24](#), "Auto Active Test" .

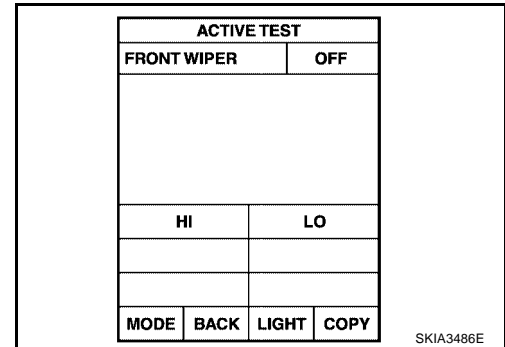

When front wipers are operating and when stopped, measure voltage between IPDM E/R harness connector E122 terminal 43 and ground.

IPDM E/R		(-)	Condition	Voltage (Approx.)
(+) Connector Terminal				
E122	43	Ground	Wiper operating	Battery voltage
			Wiper stopped	0V

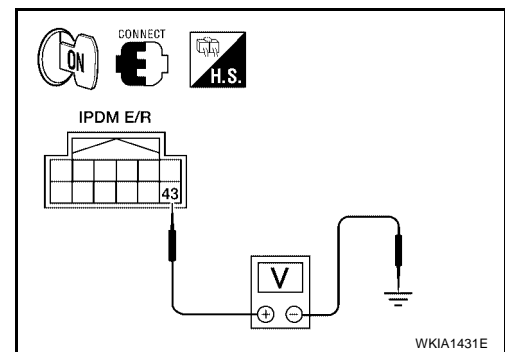

OK or NG

- OK >> Replace IPDM E/R. Refer to [PG-32](#), "Removal and Installation of IPDM E/R" .
- NG >> Replace front wiper motor. Refer to [WW-27](#), "WIPER MOTOR AND LINKAGE" .

ONLY FRONT WIPER LOW DOES NOT OPERATE

Inspection Procedure

1. CHECK IPDM E/R TO FRONT WIPERS

☑ With CONSULT-II

1. Select "IPDM E/R" with CONSULT-II, and select "ACTIVE TEST" on "SELECT DIAG MODE" screen.
2. Select "FRONT WIPER" on "SELECT TEST ITEM" screen.
3. Select "LO" on "ACTIVE TEST" screen.
4. Confirm front wiper low operation.

☒ Without CONSULT-II

1. Turn on front wipers using auto active test. Refer to [PG-24](#), "Auto Active Test" .
2. Confirm front wiper low operation.

OK or NG

- OK >> GO TO 4.
- NG >> GO TO 2.

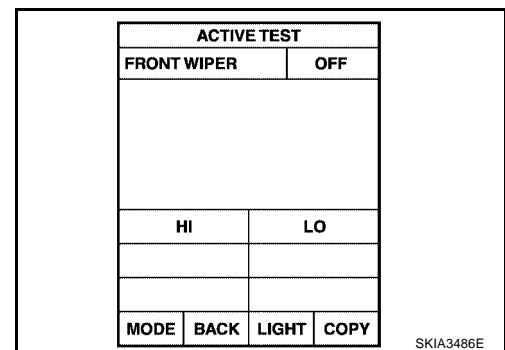

FRONT WIPER AND WASHER SYSTEM

2. IPDM E/R INSPECTION

Ⓜ With CONSULT-II

1. Select "LO" on "ACTIVE TEST" screen.

ⓧ Without CONSULT-II

1. Turn on front wipers using the auto active test. Refer to [PG-24, "Auto Active Test"](#).

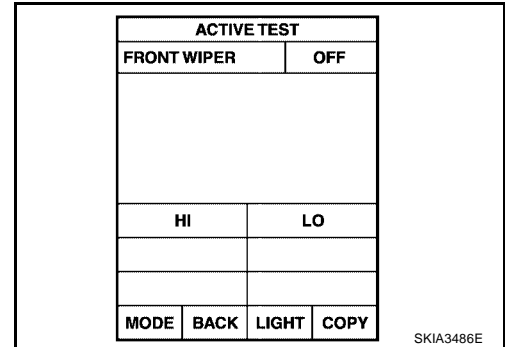

When front wiper relay is operating, check voltage between IPDM E/R terminal and ground.

IPDM E/R		(-)	Condition	Voltage (Approx.)
(+)	Terminal			
Connector	Terminal			
E121	32	Ground	Wiper operating	Battery voltage

OK or NG

OK >> GO TO 3.

NG >> Replace IPDM E/R. Refer to [PG-32, "Removal and Installation of IPDM E/R"](#).

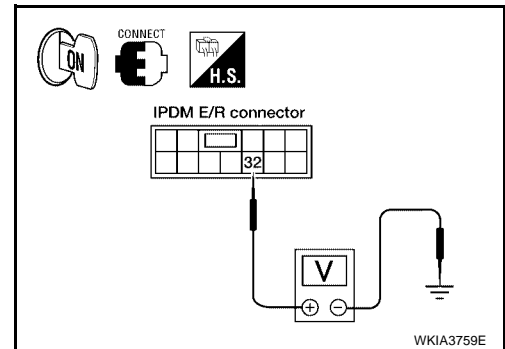

3. IPDM E/R TO FRONT WIPERS CIRCUIT INSPECTION

1. Turn ignition switch OFF.
2. Disconnect IPDM E/R connector and front wiper motor connector.
3. Check continuity between IPDM E/R harness connector terminal and front wiper motor harness connector terminal.

IPDM E/R		Front wiper motor		Continuity
Connector	Terminal	Connector	Terminal	
E121	32	E23	1	Yes

OK or NG

OK >> Replace the wiper motor. Refer to [WW-27, "WIPER MOTOR AND LINKAGE"](#).

NG >> Repair harness or connector.

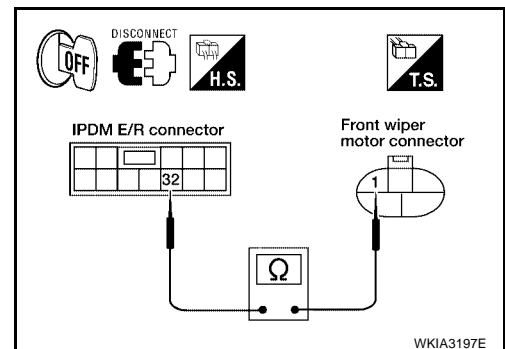

4. COMBINATION SWITCH TO BCM INSPECTION

Select "BCM" on CONSULT-II. With "WIPER" data monitor, check that "FR WIPER LO" turns ON-OFF according to operation of wiper switch.

OK or NG

OK >> Replace BCM. Refer to [BCS-27, "Removal and Installation"](#).

NG >> Replace wiper switch. Refer to [WW-28, "WIPER AND WASHER SWITCH"](#).

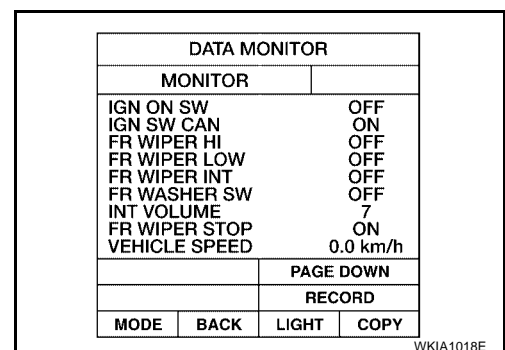

FRONT WIPER AND WASHER SYSTEM

ONLY FRONT WIPER HI DOES NOT OPERATE

Inspection Procedure

1. CHECK IPDM E/R TO FRONT WIPERS

Ⓟ With CONSULT-II

1. Select "IPDM E/R" with CONSULT-II, and select "ACTIVE TEST" on "SELECT DIAG MODE" screen.
2. Select "FRONT WIPER" on "SELECT TEST ITEM" screen.
3. Select "HI" on "ACTIVE TEST" screen.
4. Confirm front wiper high operation.

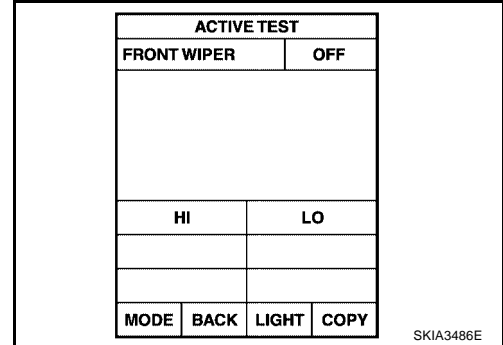

ⓧ Without CONSULT-II

1. Turn on front wipers using auto active test. Refer to [PG-24, "Auto Active Test"](#).
2. Confirm front wiper operation.

OK or NG

- OK >> GO TO 4.
 NG >> GO TO 2.

2. IPDM E/R INSPECTION

Ⓟ With CONSULT-II

1. Select "HI" on "ACTIVE TEST" screen.

ⓧ Without CONSULT-II

1. Turn on front wipers using the auto active test. Refer to [PG-24, "Auto Active Test"](#).

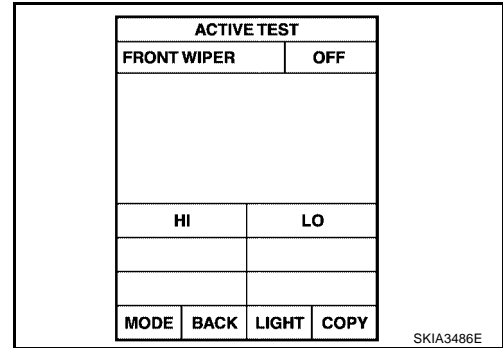

When front wiper relay high is operating, check voltage between IPDM E/R terminal and ground.

IPDM E/R		(-)	Condition	Voltage (Approx.)
(+)				
Connector	Terminal			
E121	35	Ground	Wiper operating	Battery voltage

OK or NG

- OK >> GO TO 3.
 NG >> Replace IPDM E/R. Refer to [PG-32, "Removal and Installation of IPDM E/R"](#).

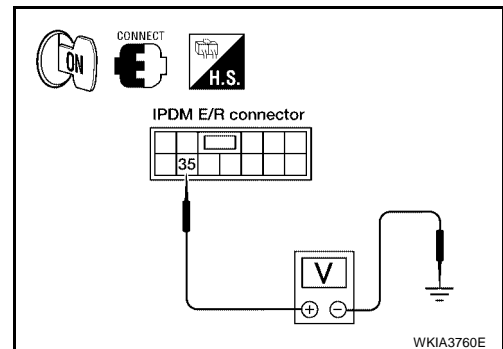

FRONT WIPER AND WASHER SYSTEM

3. IPDM E/R TO FRONT WIPERS CIRCUIT INSPECTION

1. Turn ignition switch OFF.
2. Disconnect IPDM E/R connector and front wiper motor connector.
3. Check continuity between IPDM E/R harness connector terminal and front wiper motor harness connector terminal.

IPDM E/R		Front wiper motor		Continuity
Connector	Terminal	Connector	Terminal	
E121	35	E23	4	Yes

OK or NG

- OK >> Replace the wiper motor. Refer to [WW-27, "WIPER MOTOR AND LINKAGE"](#).
- NG >> Repair harness or connector.

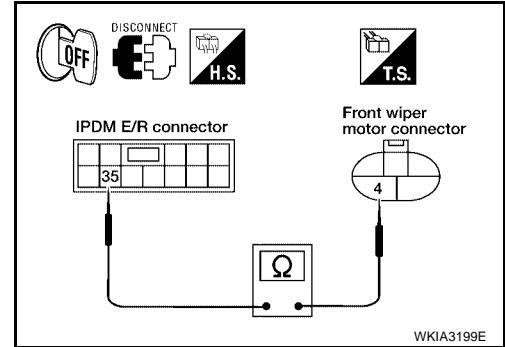

4. COMBINATION SWITCH TO BCM INSPECTION

Select "BCM" on CONSULT-II. With "WIPER" data monitor, check that "FR WIPER HI" turns ON-OFF according to operation of wiper switch.

OK or NG

- OK >> Replace BCM. Refer to [BCS-27, "Removal and Installation"](#).
- NG >> Replace wiper switch. Refer to [WW-28, "WIPER AND WASHER SWITCH"](#).

DATA MONITOR	
MONITOR	
IGN ON SW	OFF
IGN SW CAN	ON
FR WIPER HI	OFF
FR WIPER LOW	OFF
FR WIPER INT	OFF
FR WASHER SW	OFF
INT VOLUME	7
FR WIPER STOP	ON
VEHICLE SPEED	0.0 km/h
PAGE DOWN	
RECORD	
MODE	BACK
LIGHT	COPY

ONLY FRONT WIPER INT DOES NOT OPERATE

Inspection Procedure

1. COMBINATION SWITCH TO BCM INSPECTION

Select "BCM" on CONSULT-II. With "WIPER" data monitor, check that "FR WIPER INT" turns ON-OFF according to operation of wiper switch.

OK or NG

- OK >> Replace BCM. Refer to [BCS-27, "Removal and Installation"](#).
- NG >> Replace wiper switch. Refer to [WW-28, "WIPER AND WASHER SWITCH"](#).

DATA MONITOR	
MONITOR	
IGN ON SW	OFF
IGN SW CAN	ON
FR WIPER HI	OFF
FR WIPER LOW	OFF
FR WIPER INT	OFF
FR WASHER SW	OFF
INT VOLUME	7
FR WIPER STOP	ON
VEHICLE SPEED	0.0 km/h
PAGE DOWN	
RECORD	
MODE	BACK
LIGHT	COPY

FRONT WIPER AND WASHER SYSTEM

FRONT WIPER INTERMITTENT OPERATION SWITCH POSITION CANNOT BE ADJUSTED

Inspection Procedure

1. COMBINATION SWITCH TO BCM INSPECTION

Select "BCM" on CONSULT-II. With "WIPER" data monitor, check that "INT VOLUME" changes in order from 1 to 7 according to operation of the intermittent switch dial position.

OK or NG

- OK >> Replace BCM. Refer to [BCS-27, "Removal and Installation"](#).
- NG >> Replace wiper switch. Refer to [WW-28, "WIPER AND WASHER SWITCH"](#).

DATA MONITOR			
MONITOR			
IGN ON SW		OFF	
IGN SW CAN		ON	
FR WIPER HI		OFF	
FR WIPER LOW		OFF	
FR WIPER INT		OFF	
FR WASHER SW		OFF	
INT VOLUME		7	
FR WIPER STOP		ON	
VEHICLE SPEED		0.0 km/h	
		PAGE DOWN	
		RECORD	
MODE	BACK	LIGHT	COPY

WKIA1018E

WIPERS DO NOT WIPE WHEN FRONT WASHER OPERATES

Inspection Procedure

1. COMBINATION SWITCH TO BCM INSPECTION

Select "BCM" on CONSULT-II. With "WIPER" data monitor, check that "FR WASHER SW" turns ON-OFF according to operation of front washer switch.

OK or NG

- OK >> Replace BCM. Refer to [BCS-27, "Removal and Installation"](#).
- NG >> Replace wiper switch. Refer to [WW-28, "WIPER AND WASHER SWITCH"](#).

DATA MONITOR			
MONITOR			
IGN ON SW		OFF	
IGN SW CAN		ON	
FR WIPER HI		OFF	
FR WIPER LOW		OFF	
FR WIPER INT		OFF	
FR WASHER SW		OFF	
INT VOLUME		7	
FR WIPER STOP		ON	
VEHICLE SPEED		0.0 km/h	
		PAGE DOWN	
		RECORD	
MODE	BACK	LIGHT	COPY

WKIA1018E

FRONT WIPERS OPERATE FOR 10 SECONDS, STOP FOR 20 SECONDS, AND AFTER REPEATING THIS OPERATION FIVE TIMES, THEY BECOME INOPERATIVE

CAUTION:

- When auto stop signal has not varied for 10 seconds or longer while IPDM E/R is operating front wipers, IPDM E/R considers front wipers locked and stops wiper output, which causes this symptom.
- This status can be checked by using IPDM E/R "DATA MONITOR". Under this condition, "WIP PROT" reads "BLOCK".

Inspection Procedure

1. CHECK IPDM E/R TO FRONT WIPER MOTOR

 With CONSULT-II

Select "IPDM E/R" with CONSULT-II. With data monitor, confirm that "WIP AUTO STOP" changes from "ACT P" to "STOP P" according to wiper operation.

 Without CONSULT-II

GO TO 2.

OK or NG

- OK >> Replace IPDM E/R. Refer to [PG-32, "Removal and Installation of IPDM E/R"](#).
- NG >> GO TO 2.

DATA MONITOR			
MONITOR			
MOTOR FAN REQ		1	
AC COMP REQ		OFF	
TAIL&CLR REQ		OFF	
HL LO REQ		OFF	
HL HI REQ		OFF	
FR FOG REQ		OFF	
FR WIP REQ		STOP	
WIP AUTO STOP		STOP P	
WIP PROT		OFF	
		Page DOWN	
		RECORD	
MODE	BACK	LIGHT	COPY

SKIA5301E

FRONT WIPER AND WASHER SYSTEM

2. IPDM E/R TO FRONT WIPER MOTOR AUTO STOP CIRCUIT INSPECTION

1. Turn ignition switch OFF.
2. Disconnect IPDM E/R connector and front wiper motor connector.
3. Check continuity between IPDM E/R harness connector E122 terminal 43 and front wiper motor harness connector E23 terminal 5.

IPDM E/R		Front wiper motor		Continuity
Connector	Terminal	Connector	Terminal	
E122	43	E23	5	Yes

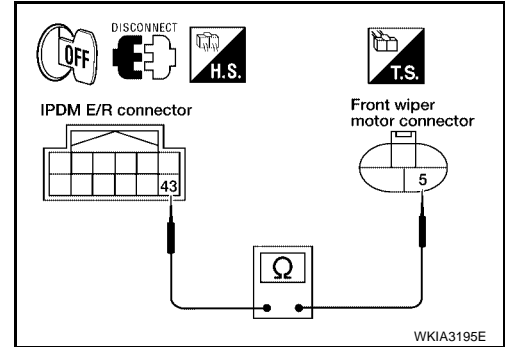

4. Check continuity between IPDM E/R harness connector E122 terminal 43 and ground.

IPDM E/R			Continuity
Connector	Terminal		
E122	43	Ground	No

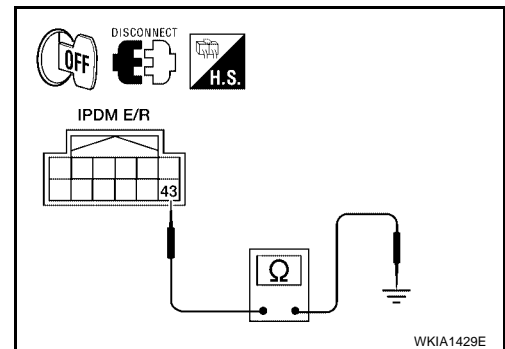

OK or NG

- OK >> Connect connectors. GO TO 3.
- NG >> Repair harness or connector.

3. IPDM E/R TO FRONT WIPER MOTOR (3) INSPECTION

While front wiper motor is stopped and while operating, measure voltage between IPDM E/R harness connector E122 terminal 43 and ground.

IPDM E/R		(-)	Condition	Voltage (Approx.)
(+)				
Connector	Terminal			
E122	43	Ground	Wiper operating	Battery voltage
			Wiper stopped	0V

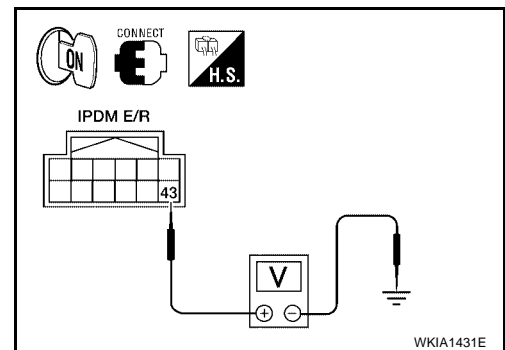

OK or NG

- OK >> Replace IPDM E/R. Refer to [PG-32, "Removal and Installation of IPDM E/R"](#).
- NG >> Replace front wiper motor. Refer to [WW-27, "WIPER MOTOR AND LINKAGE"](#).

FRONT WIPER AND WASHER SYSTEM

EKS00HJV

Removal and Installation

FRONT WIPER ARMS

Removal

1. Remove wiper arm covers and wiper arm nuts.
2. Remove front RH wiper arm and front LH wiper arm.
3. Remove front RH blade assembly and front LH blade assembly.

Installation

1. Operate wiper motor one full cycle, then turn "OFF" (Auto Stop).
2. Clean up the pivot area as shown. This will reduce possibility of wiper arm looseness.

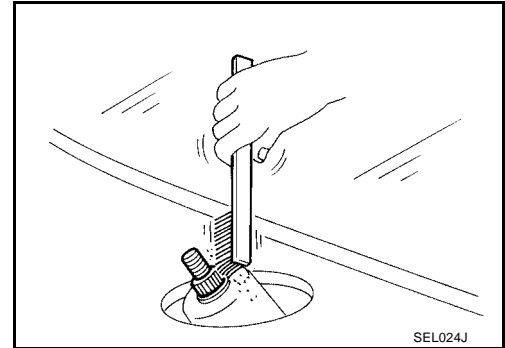

3. Install front RH blade assembly and front LH blade assembly.
4. Install front RH wiper arm and front LH wiper arm.
5. Ensure that wiper blades stop within proper clearance. Refer to [WW-26, "FRONT WIPER ARM ADJUSTMENT"](#).

FRONT WIPER ARM ADJUSTMENT

1. Operate windshield washer and wiper motor one full cycle, then turn "OFF" (Auto Stop).
2. Lift the wiper blade up and then rest it onto glass surface, check the blade clearance "L1" and "L2".

Clearance "L1" : 24.5 - 39.5 mm (0.965 - 1.555 in)

Clearance "L2" : 23.5 - 38.5 mm (0.925 - 1.516 in)

3. Remove wiper arm covers and wiper arm nuts.
4. Adjust front wiper arms on wiper motor pivot shafts to obtain above specified blade clearances.
5. Tighten wiper arm nuts to specified torque, and install wiper arm covers.

Front wiper arm nuts : 23.6 N·m (2.4 kg·m, 17 ft·lb)

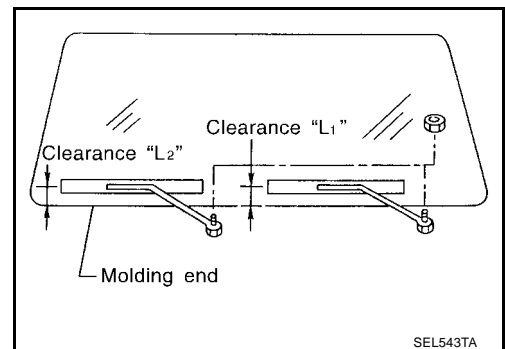

FRONT WIPER AND WASHER SYSTEM

WIPER MOTOR AND LINKAGE

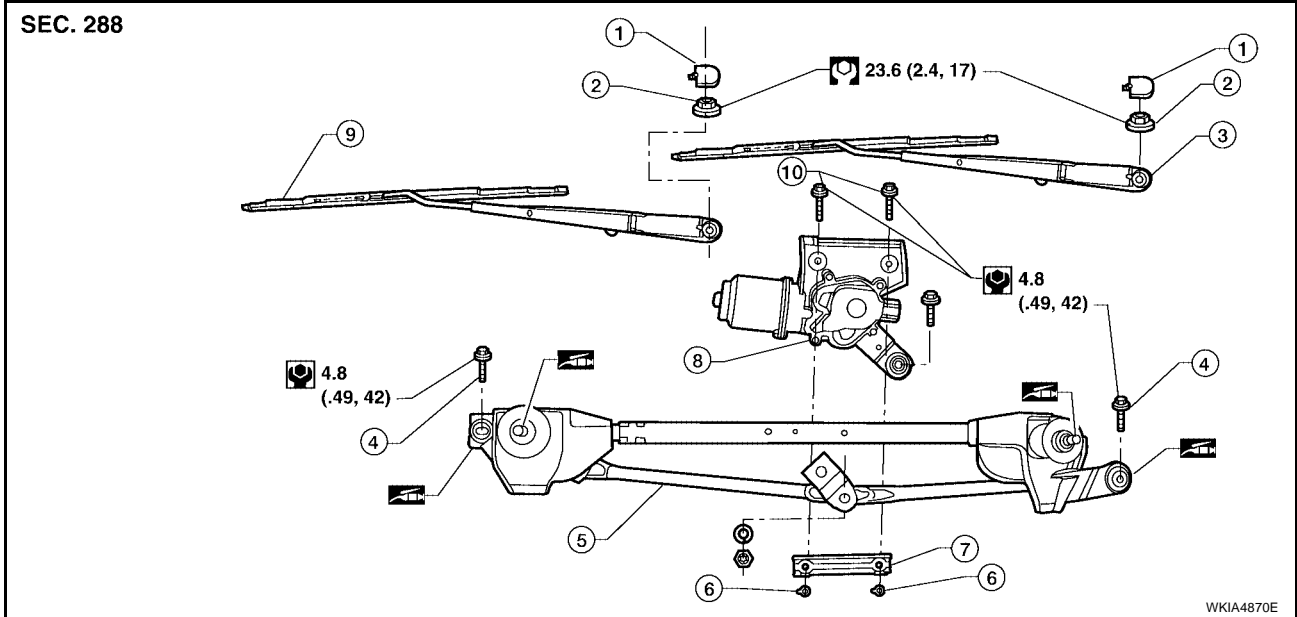

- | | | |
|--------------------------------|-------------------------|------------------------------------------|
| 1. Wiper arm covers | 2. Wiper arm nuts | 3. Front LH wiper arm and blade assembly |
| 4. Wiper frame bolts | 5. Wiper frame assembly | 6. Wiper motor to frame nuts |
| 7. Wiper motor spacer | 8. Wiper motor | 9. Front RH wiper arm and blade assembly |
| 10. Wiper motor to frame bolts | | |

Removal

1. Remove the cowl top. Refer to [EI-17, "COWL TOP"](#).
2. Remove wiper frame bolts, and remove wiper frame assembly.

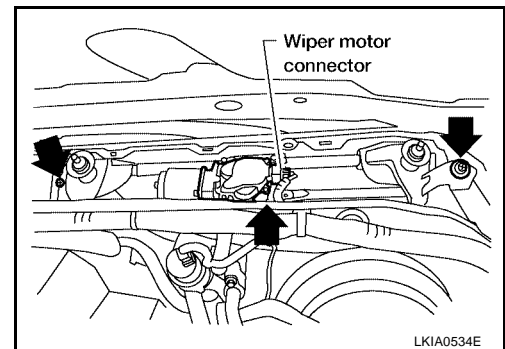

3. Remove wiper motor from wiper frame assembly.

Installation

CAUTION:

- Do not drop the wiper motor or cause it to contact other parts.
 - Check the grease conditions of the motor arm and wiper link joint(s). Apply grease if necessary.
1. Connect wiper motor to connector. Turn the wiper switch ON to operate wiper motor, then turn the wiper switch OFF (auto stop).
 2. Disconnect wiper motor electrical connector.
 3. Install wiper motor to wiper frame assembly, and install wiper frame assembly.
 4. Connect wiper motor electrical connector.
 5. Install cowl top. Refer to [EI-17, "COWL TOP"](#).

FRONT WIPER AND WASHER SYSTEM

WASHER HOSE LAYOUT

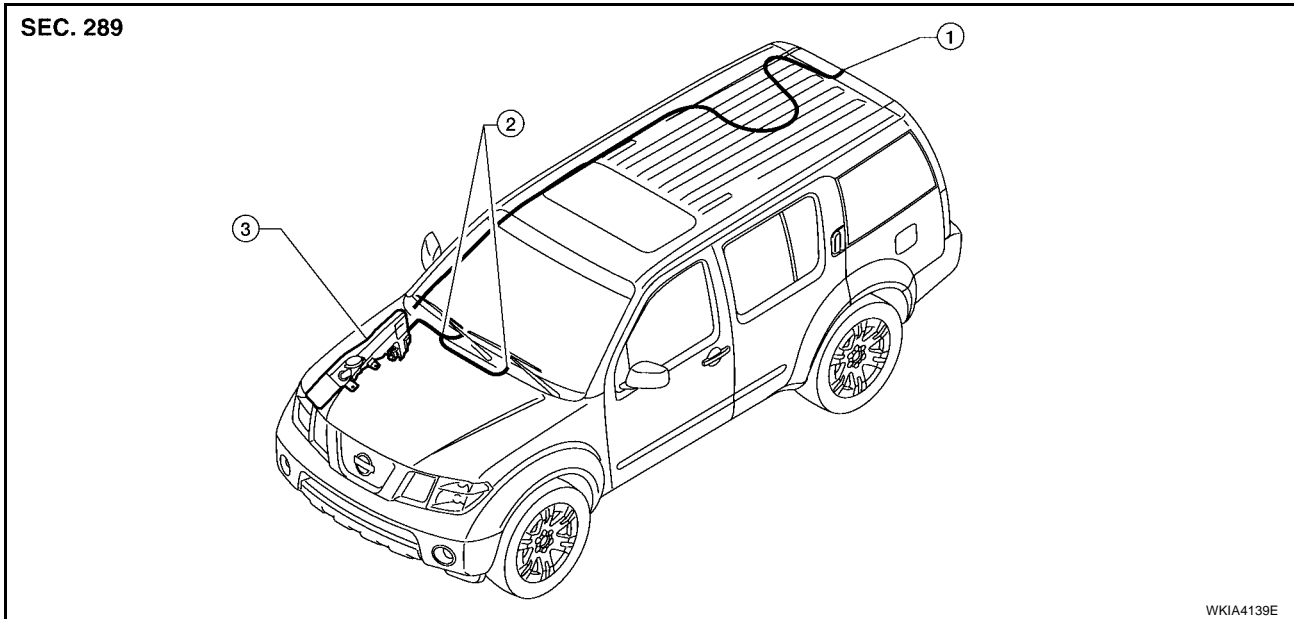

1. Rear washer nozzle

2. Washer nozzles

3. Washer fluid reservoir

WASHER NOZZLES

Removal

1. Remove the cowl top. Refer to [EI-17, "COWL TOP"](#).
2. Remove washer nozzles.

Installation

Installation is in the reverse order of removal.

WIPER AND WASHER SWITCH

Removal

1. Remove instrument lower cover LH. Refer to [IP-14, "LOWER INSTRUMENT PANEL LH"](#).
2. Remove steering column cover lower and steering column cover upper.
3. Disconnect wiper and washer switch connector.
4. Pinch tabs at wiper and washer switch base and slide switch away from steering column.

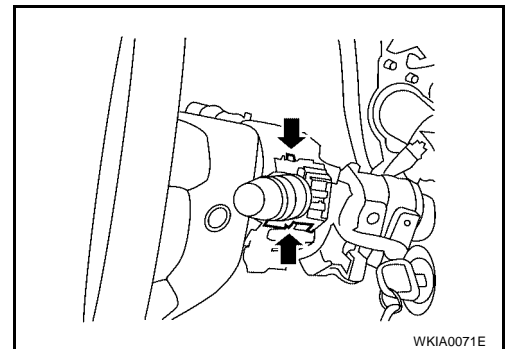

Installation

Installation is in the reverse order of removal.

FRONT WIPER AND WASHER SYSTEM

WASHER FLUID RESERVOIR

Removal

1. Remove passenger front fender protector. Refer to [EI-21, "Removal and Installation of Front Fender Protector"](#).
2. Remove clip, then remove washer fluid reservoir filler neck from washer fluid reservoir.

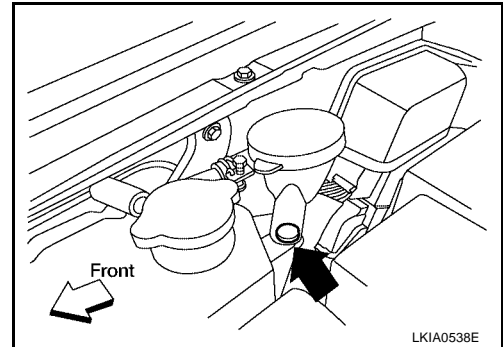

3. Disconnect front and rear washer hoses.
4. Disconnect front and rear washer motor connector.
5. Disconnect washer fluid level sensor connector.

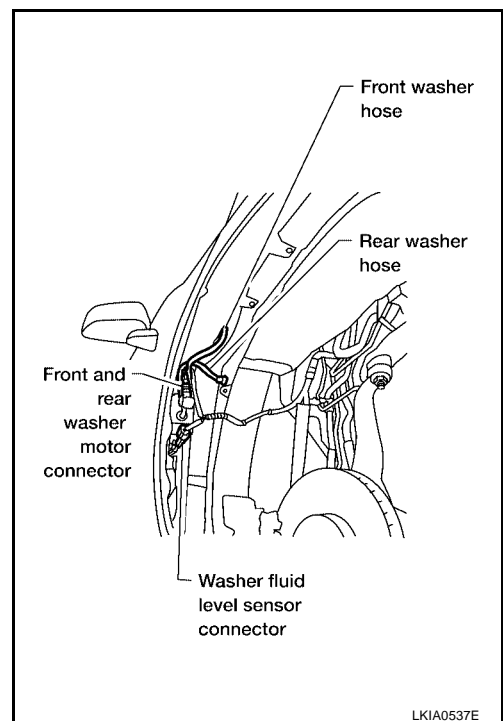

6. Remove washer fluid reservoir screws and remove washer fluid reservoir.

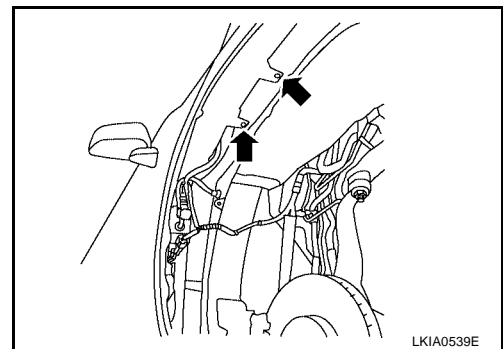

Installation

CAUTION:

After installation, add water up to the upper level of the washer fluid reservoir inlet and check for water leaks.

Installation is in the reverse order of removal.

A
B
C
D
E
F
G
H
I
J
L
M

WW

FRONT WIPER AND WASHER SYSTEM

WASHER MOTOR

Removal

1. Remove washer fluid reservoir. Refer to [WW-29, "WASHER FLUID RESERVOIR"](#).
2. Slide retaining ring upward to release front and rear washer motor.

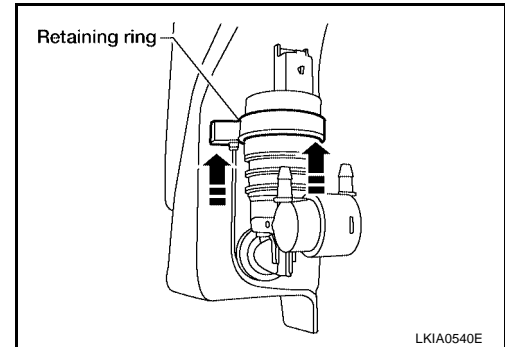

3. Remove front and rear washer motor from washer fluid reservoir.

Installation

CAUTION:

When installing front and rear washer motor, there should be no packing twists, etc.

Installation is in the reverse order of removal.

WASHER FLUID LEVEL SENSOR

Removal

1. Remove washer fluid reservoir. Refer to [WW-29, "WASHER FLUID RESERVOIR"](#).
2. Lift level sensor out of washer fluid reservoir in the direction of the arrow as shown.

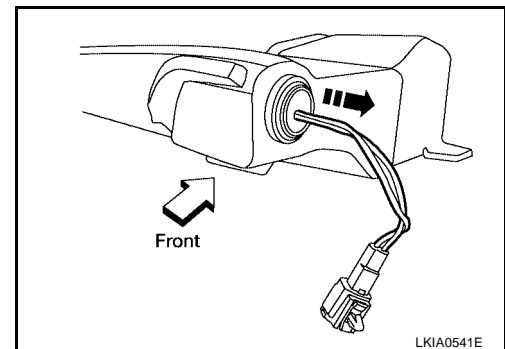

Installation

Installation is in the reverse order of removal.

Washer Nozzle Adjustment

- This vehicle is equipped with adjustable washer nozzles.
- If not satisfied with washer fluid spray coverage, confirm that the washer nozzle is installed correctly.
- If the washer nozzle is installed correctly, and the washer fluid spray coverage is not satisfactory, re-aim washer nozzle.

EKS00FZQ

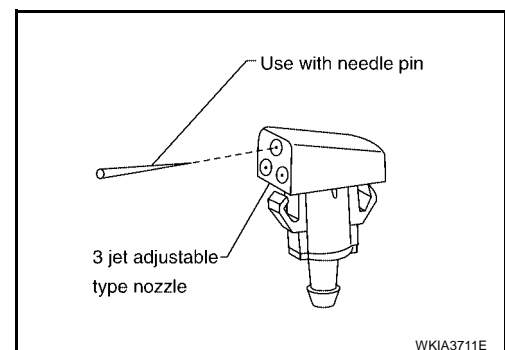

REAR WIPER AND WASHER SYSTEM

PDF:28710

REAR WIPER AND WASHER SYSTEM

Components Parts and Harness Connector Location

EKS00FZW

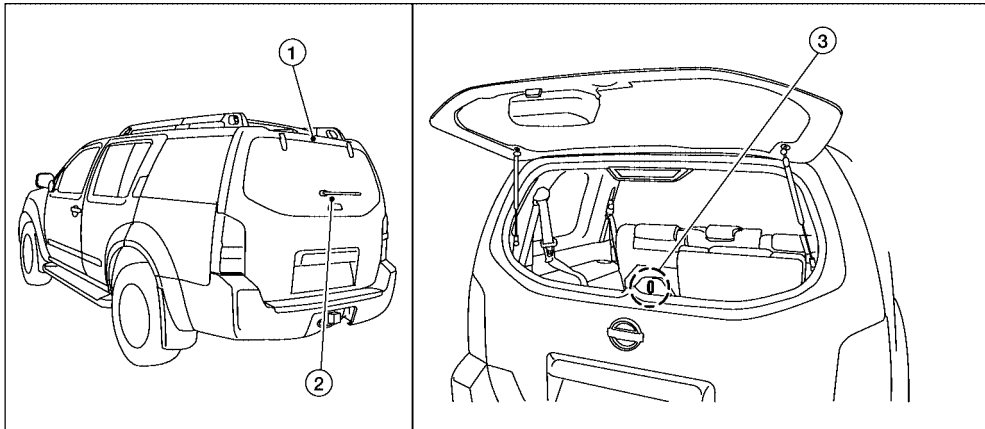

WKIA4895E

1. Rear washer nozzle

2. Rear wiper motor
D602

3. Glass hatch ajar switch
D503

System Description

EKS00FZX

- The wiper switch (combination switch) is composed of a combination of 5 output terminals and 5 input terminals. Terminal combination status is read by the BCM (body control module) when switch is turned ON.
- The BCM controls rear wiper ON and INT (intermittent) operation.

Power is supplied at all times

- through 50A fusible link (letter **g**, located in fuse and fusible link box)
- to BCM terminal 70.

With the ignition switch in ON or START position, power is supplied

- through 10A fuse [No. 15, located in the fuse block (J/B)]
- to combination switch terminal 2, and
- through 10A fuse [No. 1, located in the fuse block (J/B)]
- to BCM terminal 38.

Ground is supplied

- to BCM terminal 67 and
- to combination switch terminal 9
- through grounds M57, M61 and M79.

REAR WIPER OPERATION

When the ignition switch is in the ON or START position, and the rear wiper switch is in the ON position, the BCM detects a rear wiper ON request through the combination switch (wiper switch) reading function.

The BCM will first check the status of the glass hatch ajar switch before supplying power to the rear wiper motor. If the glass hatch ajar switch is closed (grounded) the BCM will not turn on the rear wiper motor. If the glass hatch ajar switch is open (not grounded) the BCM will control the rear wiper motor as follows.

Power is supplied

- through BCM terminal 55
- to rear wiper motor terminal 4.

Ground is supplied

- to rear wiper motor terminal 1
- through grounds D406 and D504.

With power and ground supplied, the rear wiper motor operates.

A
B
C
D
E
F
G
H
I
J
L
M

WW

REAR WIPER AND WASHER SYSTEM

If the BCM detects the glass hatch ajar switch signal during rear wiper motor operation, the BCM will operate the rear wiper motor to the auto stop position. Once the glass hatch ajar switch signal returns to open (not grounded) for 5 or more seconds, the BCM will resume rear wiper motor operation.

INTERMITTENT OPERATION

The rear wiper motor operates the wiper arm at low speed approximately every 7 seconds.

When the wiper switch is in the rear wiper INT position, the BCM detects a rear wiper INT request through the combination switch (wiper switch) reading function.

When BCM operates rear wiper motor, power is supplied

- through BCM terminal 55
- to rear wiper motor terminal 4.

Ground is supplied

- to rear wiper motor terminal 1
- through grounds D406 and D504.

With power and ground supplied, the rear wiper operates in intermittent mode.

AUTO STOP OPERATION

When the rear wiper arm is not located at the base of the rear window, and the rear wiper switch is turned OFF, the rear wiper motor will continue to operate until the rear wiper arm is at the base of the rear window.

When the rear wiper arm reaches the base, rear wiper motor terminals 2 and 1 are connected.

Ground is supplied

- to BCM terminal 44
- through rear wiper motor terminal 2
- through rear wiper motor terminal 1
- through grounds D406 and D504.

REAR WASHER OPERATION

When the ignition switch is in the ON or START position, and the front and rear washer switches are OFF, the front and rear washer motor is supplied power

- through 10A fuse [No. 15, located in the fuse block (J/B)]
- through combination switch (wiper switch) terminal 2
- through combination switch (wiper switch) terminal 3
- to front and rear washer motor terminal 2.

When the rear wiper switch is in rear washer position, the BCM detects a rear washer signal by BCM wiper switch reading function. Combination switch ground is supplied

- to front and rear washer motor terminal 1
- through combination switch (wiper switch) terminal 4
- through combination switch (wiper switch) terminal 9
- through grounds M57, M61 and M79.

With ground supplied, the front and rear washer motor is operated in the rear direction.

When the BCM detects that the rear washer motor has operated for 0.4 seconds or longer, BCM operates the rear wiper motor.

When the BCM detects that the rear washer switch is in OFF, the rear wiper motor cycles approximately 3 times and then stops.

If the rear washer is operated with the rear wiper switch in the INT position, normal rear wiper operation will take over. Once the rear washer switch is released the rear wiper will return to INT operation.

BCM WIPER SWITCH READING FUNCTION

Refer to [BCS-3, "COMBINATION SWITCH READING FUNCTION"](#) .

REAR WIPER AND WASHER SYSTEM

Wiring Diagram — WIP/R —

EKS00FZY

WW-WIP/R-01

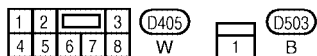
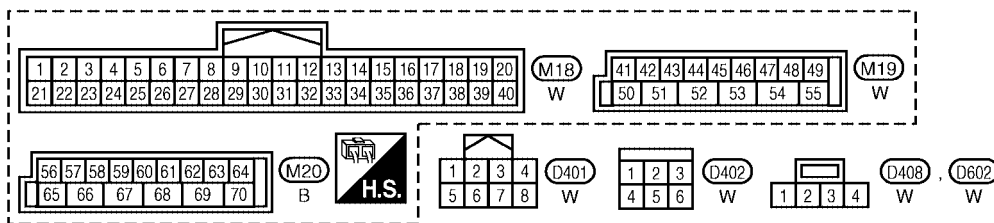
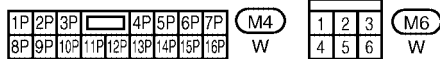
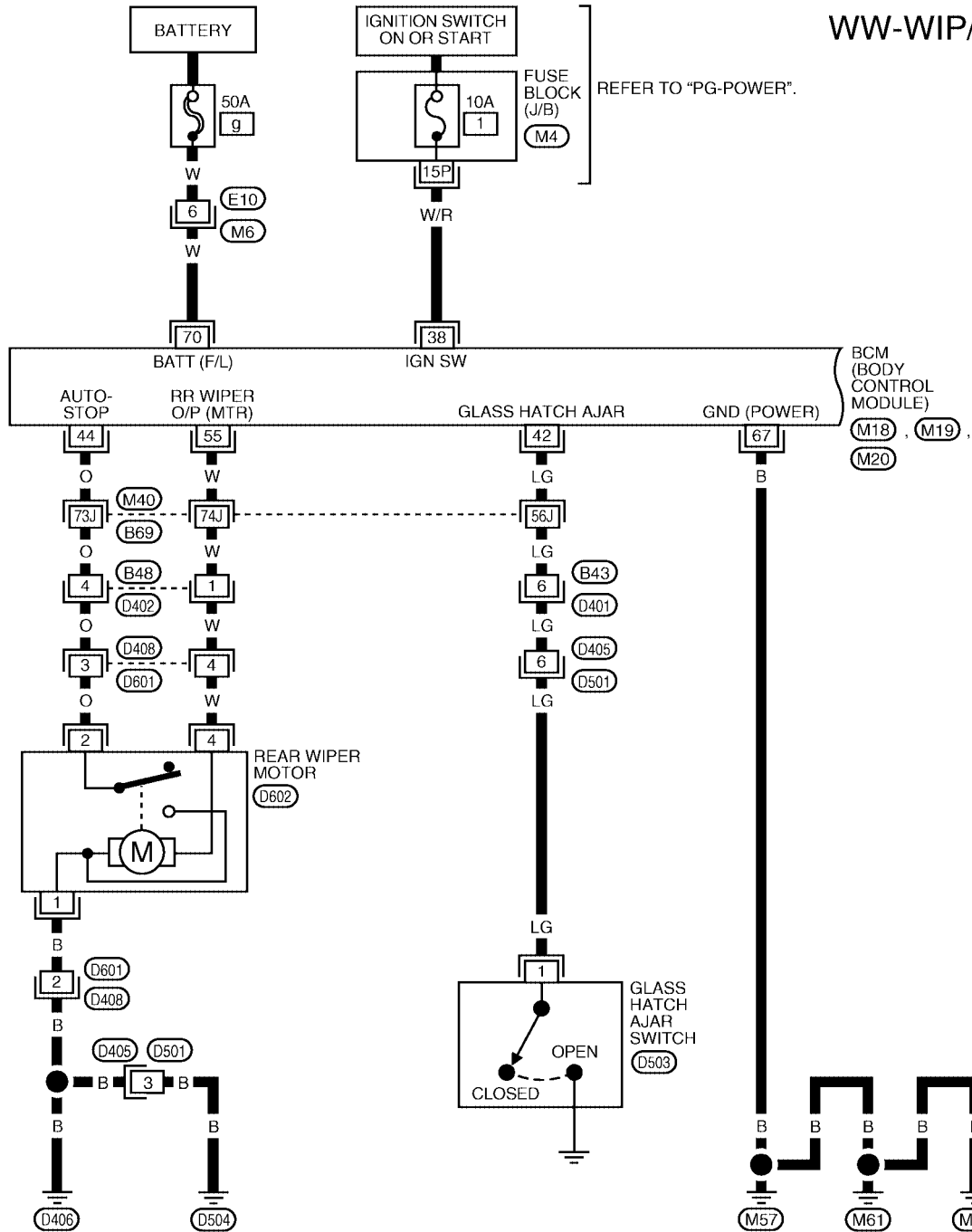

REFER TO THE FOLLOWING.

(M40) - SUPER MULTIPLE JUNCTION (SMJ)

WKWA4344E

REAR WIPER AND WASHER SYSTEM

WW-WIP/R-02

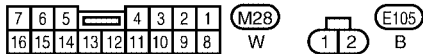
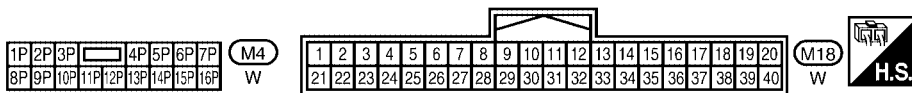
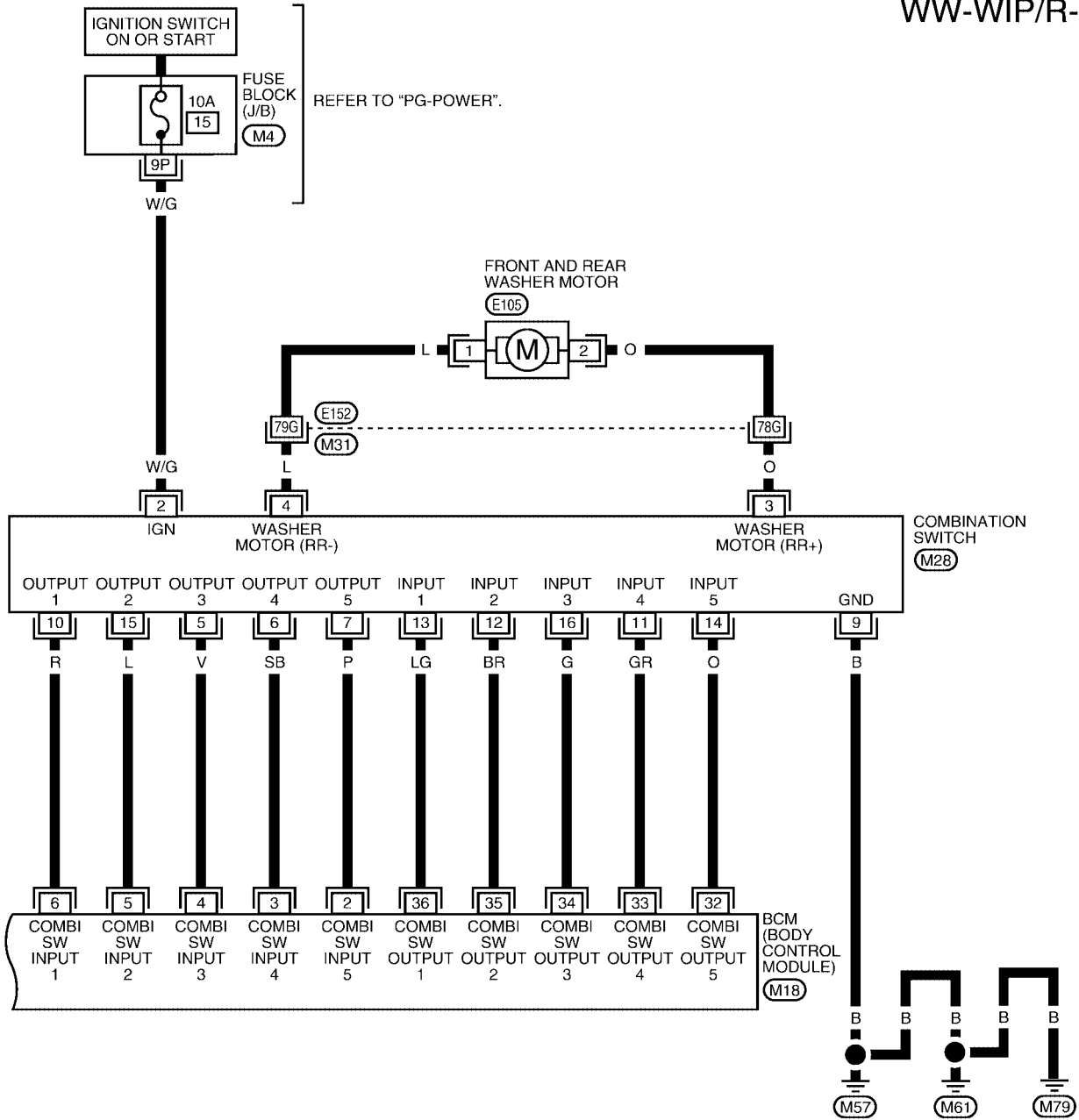

REFER TO THE FOLLOWING.

M31 - SUPER MULTIPLE JUNCTION (SMJ)

WKWA1968E

REAR WIPER AND WASHER SYSTEM

Terminals and Reference Values for BCM

EKS00FZZ

Refer to [BCS-12, "Terminals and Reference Values for BCM"](#) .

How to Proceed With Trouble Diagnosis

EKS00G00

1. Confirm the symptoms and customer complaint.
2. Understand operation description and function description. Refer to [WW-31, "System Description"](#) .
3. Perform the Preliminary Check. Refer to [WW-35, "Preliminary Check"](#) .
4. Check symptom and repair or replace the cause of malfunction.
5. Does the rear wiper operate normally? If YES: GO TO 6. If NO: GO TO 4.
6. Inspection End.

Preliminary Check

EKS00G01

Refer to [BCS-16, "BCM Power Supply and Ground Circuit Check"](#)

CONSULT-II Function (BCM)

EKS00G02

CONSULT-II can display each diagnostic item using the diagnostic test modes shown following.

BCM diagnostic test item	Diagnostic mode	Description
Inspection by part	WORK SUPPORT	Supports inspections and adjustments. Commands are transmitted to the BCM for setting the status suitable for required operation, input/output signals are received from the BCM and received data is displayed.
	DATA MONITOR	Displays BCM input/output data in real time.
	ACTIVE TEST	Operation of electrical loads can be checked by sending drive signal to them.
	SELF-DIAG RESULTS	Displays BCM self-diagnosis results.
	CAN DIAG SUPPORT MNTR	The result of transmit/receive diagnosis of CAN communication can be read.
	ECU PART NUMBER	BCM part number can be read.
	CONFIGURATION	Performs BCM configuration read/write functions.

CONSULT-II OPERATION

CAUTION:

If CONSULT-II is used with no connection of CONSULT-II CONVERTER, malfunctions might be detected in self-diagnosis depending on control unit which carries out CAN communication.

1. With the ignition switch OFF, connect CONSULT-II and CONSULT-II CONVERTER to the data link connector, then turn the ignition switch ON.

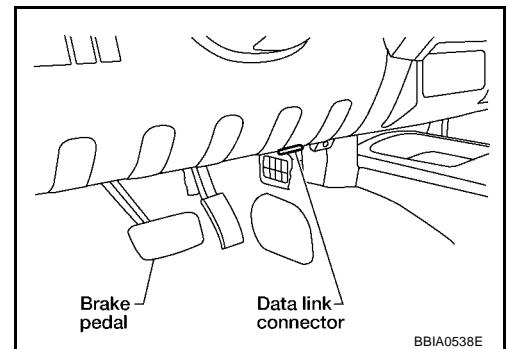

REAR WIPER AND WASHER SYSTEM

- Touch "START (NISSAN BASED VHCL)".

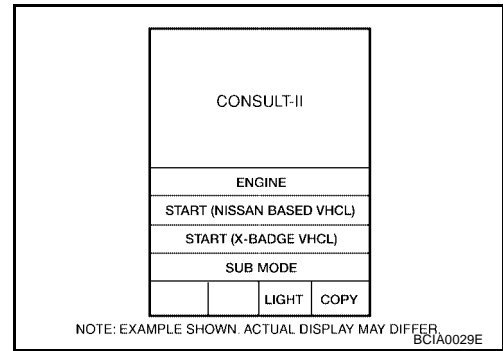

- Touch "BCM" on the "SELECT SYSTEM" screen.
If "BCM" is not indicated, go to [GI-40, "CONSULT-II Data Link Connector \(DLC\) Circuit"](#).

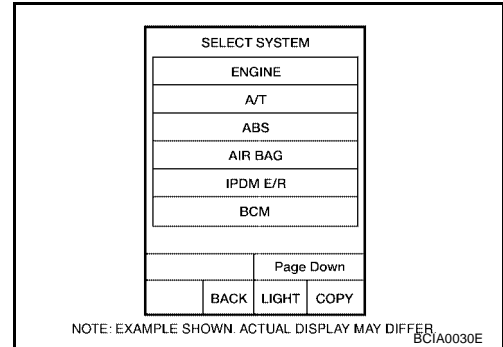

- Select the desired part to be diagnosed on the "SELECT TEST ITEM" screen.

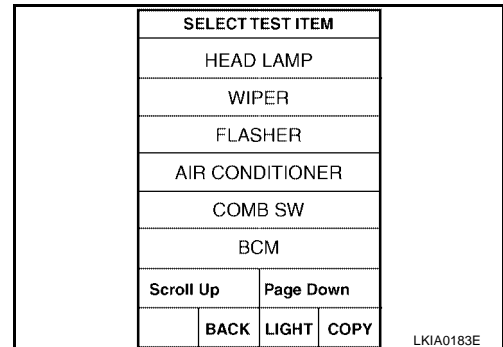

DATA MONITOR

Operation Procedure

- Touch "WIPER" on "SELECT TEST ITEM" screen.
- Touch "DATA MONITOR" on "SELECT DIAG MODE" screen.
- Touch either "ALL SIGNALS" or "SELECTION FROM MENU" on "SELECT MONITOR ITEM" screen.

ALL SIGNALS	Monitors all the items.
SELECTION FROM MENU	Selects and monitors the individual item selected.

- Touch "START".
- When "SELECTION FROM MENU" is selected, touch items to be monitored. When "ALL SIGNALS" is selected, all the items will be monitored.
- Touch "RECORD" while monitoring, then the status of the monitored item can be recorded. To stop recording, touch "STOP".

REAR WIPER AND WASHER SYSTEM

Display Item List

Monitor item name "OPERATION OR UNIT"	Contents
IGN ON SW "ON/OFF"	Displays "IGN Position (ON)/OFF, ACC Position (OFF)" status as judged from ignition switch signal.
IGN SW CAN "ON/OFF"	Displays "IGN Position (ON)/OFF, ACC Position (OFF)" status as judged from CAN communications.
FR WIPER INT "ON/OFF"	Displays "Front Wiper INT (ON)/Other (OFF)" status as judged from wiper switch signal.
FR WIPER LOW "ON/OFF"	Displays "Front Wiper LOW (ON)/Other (OFF)" status as judged from wiper switch signal.
FR WIPER HI "ON/OFF"	Displays "Front Wiper HI (ON)/Other (OFF)" status as judged from wiper switch signal.
FR WASHER SW "ON/OFF"	Displays "Front Washer Switch (ON)/Other (OFF)" status as judged from wiper switch signal.
INT VOLUME (1 - 7)	Displays intermittent operation dial position setting (1 - 7) as judged from wiper switch signal.
VEHICLE SPEED "0.0 km/h"	Displays vehicle speed as received over CAN communication.
FR WIPER STOP "ON/OFF"	Displays "Stopped (ON)/Operating (OFF)" status as judged from the auto-stop signal.
RR WIPER INT "ON/OFF"	Displays "Rear Wiper INT (ON)/Other (OFF)" status as judged from wiper switch signal.
RR WIPER ON "ON/OFF"	Displays "Rear Wiper (ON)/Other (OFF)" status as judged from wiper switch signal.
RR WASHER SW "ON/OFF"	Displays "Rear Washer Switch (ON)/Other (OFF)" status as judged from wiper switch signal.
RR WIPER STOP "ON/OFF"	Displays "Stopped (OFF)/Operating (ON)" status as judged from the auto stop switch 1.
RR AUTO STP 2 "ON/OFF"	Displays "Stopped (OFF)/Operating (ON)" status as judged from the auto stop switch 2.

ACTIVE TEST

Operation Procedure

1. Touch "WIPER" on the "SELECT TEST ITEM" screen.
2. Touch "ACTIVE TEST" on the "SELECT DIAG MODE" screen.
3. Touch item to be tested and check operation of the selected item.
4. During the operation check, touching "BACK" deactivates the operation.

Display Item List

Test item	Display on CONSULT-II screen	Description
Front wiper HI output	FR WIPER (HI)	Front wiper HI can be operated by any ON-OFF operation.
Front wiper LO output	FR WIPER (LO)	Front wiper LO can be operated by any ON-OFF operation.
Front wiper INT output	FR WIPER (INT)	Front wiper INT can be operated by any ON-OFF operation.
Rear wiper output	RR WIPER	Rear wiper can be operated by any ON-OFF operation.

Rear Wiper Does Not Operate

EKS00G03

1. REAR WIPER ACTIVE TEST

1. Select "BCM" on CONSULT-II, and select "WIPER" on "SELECT TEST ITEM" screen.
2. Select "ACTIVE TEST" on "SELECT DIAG MODE" screen.
3. Select "RR WIPER" on "SELECT TEST ITEM" screen.
4. Make sure rear wiper operates.

Wiper should operate.

OK or NG

- OK >> GO TO 7.
NG >> GO TO 2.

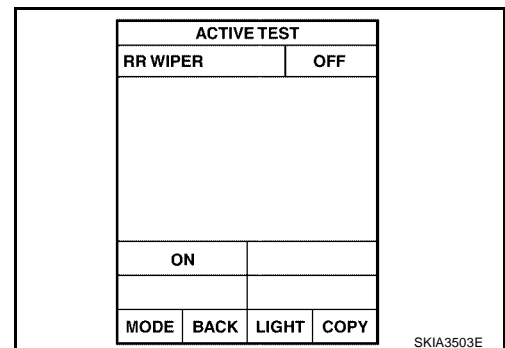

REAR WIPER AND WASHER SYSTEM

2. CHECK REAR WIPER MOTOR CIRCUIT

1. Turn ignition switch OFF.
2. Disconnect BCM connector and rear wiper motor connector.
3. Check continuity between BCM harness connector M19 terminal 55 and rear wiper motor harness connector D602 terminal 4.

55 - 4 : Continuity should exist.

OK or NO

- OK >> GO TO 3.
NO >> Repair harness or connector.

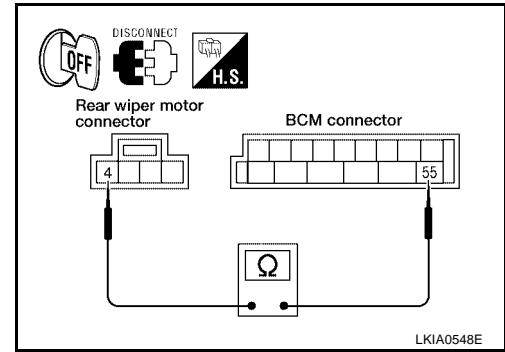

3. CHECK GLASS HATCH AJAR SWITCH

1. Make sure hatch glass is closed.
2. Check continuity between BCM connector M19 terminal 42 and ground.

42 - Ground : Continuity should not exist.

OK or NG

- OK >> GO TO 4.
NG >> Repair harness if shorted. If not, refer to [BL-84, "Diagnostic Procedure 1"](#) for further glass hatch ajar switch diagnosis.

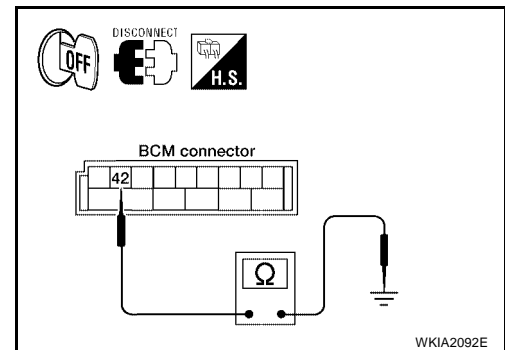

4. CHECK REAR WIPER MOTOR SHORT CIRCUIT

Check continuity between rear wiper motor harness connector D602 terminal 4 and ground.

4 - Ground : Continuity should not exist.

OK or NG

- OK >> GO TO 5.
NG >> After repairing harness, be sure to disconnect battery negative cable, and then reconnect it. After the battery cable is reconnected, the steering angle sensor neutral position must be reset on vehicles equipped with VDC. Refer to [BRC-58, "Adjustment of Steering Angle Sensor Neutral Position"](#).

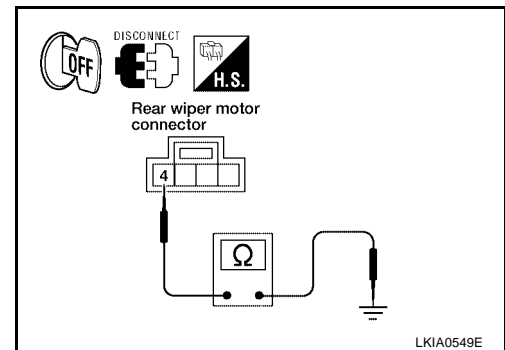

5. CHECK GROUND CIRCUIT

Check continuity between rear wiper motor harness connector D602 terminal 1 and ground.

1 - Ground : Continuity should exist.

OK or NG

- OK >> GO TO 6.
NG >> Repair harness or connector.

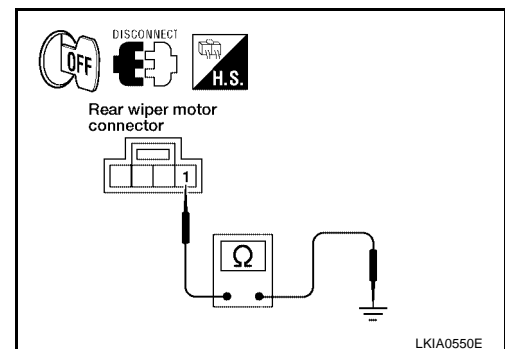

REAR WIPER AND WASHER SYSTEM

6. CHECK REAR WIPER OPERATING

1. Connect BCM connector and rear wiper motor connector.
2. Select "RR WIPER" during "ACTIVE TEST". Refer to [WW-37, "ACTIVE TEST"](#). When rear wiper is operating, check voltage between BCM harness connector terminal and ground.

BCM (+)		(-)	Condition	Voltage (Approx.)
Connector	Terminal			
M19	55	Ground	Stopped	0V
			ON operation	Battery voltage

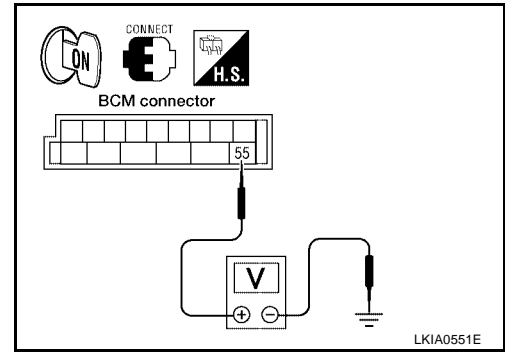

OK or NG

- OK >> Replace rear wiper motor. Refer to [WW-43, "REAR WIPER MOTOR"](#).
- NG >> Replace BCM. Refer to [BCS-27, "Removal and Installation"](#).

7. CHECK COMBINATION SWITCH INPUT SIGNAL

Select "BCM" on CONSULT-II. With "WIPER" data monitor, make sure "RR WIPER INT", "RR WIPER ON" turn ON-OFF according to operation of wiper switch.

When wiper switch is in INT position : RR WIPER INT ON

When wiper switch is in ON position : RR WIPER ON ON

OK or NG

- OK >> Replace BCM. Refer to [BCS-27, "Removal and Installation"](#).
- NG >> Check the wiper switch. Refer to [BCS-3, "COMBINATION SWITCH READING FUNCTION"](#).

DATA MONITOR	
MONITOR	
RR WIPER INT	ON
RR WIPER ON	ON

SKIA4243E

Rear Wiper Stop Position Is Incorrect

EKS00G04

1. CHECK COMBINATION SWITCH INPUT SIGNAL

Select "BCM" on CONSULT-II. With "WIPER" data monitor, make sure "RR WIPER STOP" turns ON-OFF according to wiper operation.

When wiper switch is in OFF position : RR WIPER STOP OFF

OK or NG

- OK >> Replace BCM. Refer to [BCS-27, "Removal and Installation"](#).
- NG >> GO TO 2.

DATA MONITOR	
MONITOR	
RR WIPER STOP	OFF

SKIA4244E

REAR WIPER AND WASHER SYSTEM

2. CHECK REAR WIPER MOTOR CIRCUIT

1. Turn ignition switch OFF.
2. Disconnect BCM connector and rear wiper motor connector.
3. Check continuity between BCM harness connector M19 terminal 44 and rear wiper motor harness connector D602 terminal 2.

44 - 2 : Continuity should exist.

OK or NG

- OK >> GO TO 3.
NG >> Repair harness or connector.

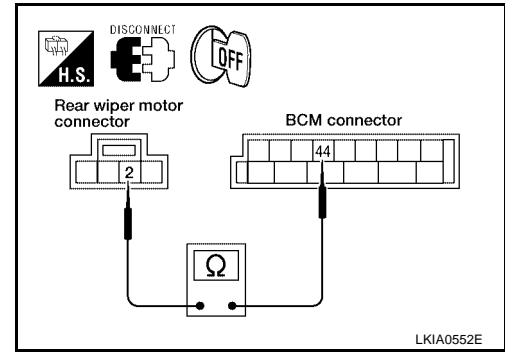

3. CHECK REAR WIPER MOTOR SHORT CIRCUIT

Check continuity between rear wiper motor harness connector D602 terminal 2 and ground.

2 - Ground : Continuity should not exist.

OK or NG

- OK >> GO TO 4.
NG >> Repair harness or connector.

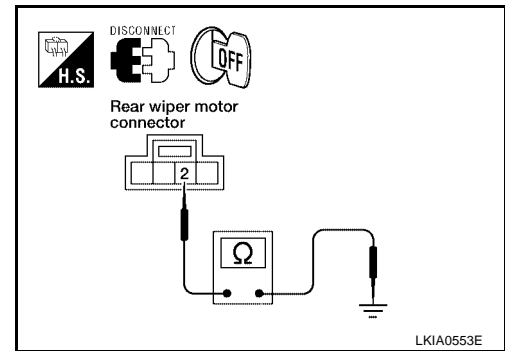

4. CHECK GROUND CIRCUIT

Check continuity between rear wiper motor harness connector D602 terminal 1 and ground.

1 - Ground : Continuity should exist.

OK or NG

- OK >> GO TO 5.
NG >> Repair harness or connector.

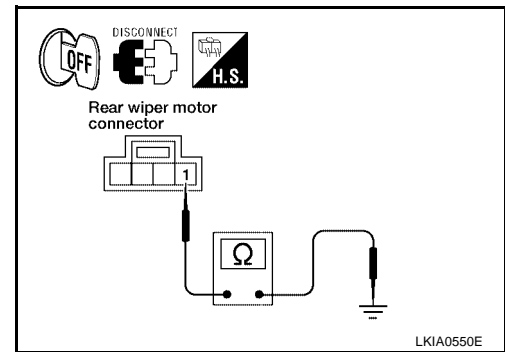

5. CHECK AUTO STOP SIGNAL

1. Connect BCM connector.
2. Turn ignition switch ON.
3. Check voltage between rear wiper motor harness connector D602 terminal 2 and ground.

2 - Ground : Battery voltage should exist.

OK or NG

- OK >> Replace BCM. Refer to [BCS-27, "Removal and Installation"](#) .
NG >> Replace rear wiper motor. Refer to [WW-43, "REAR WIPER MOTOR"](#) .

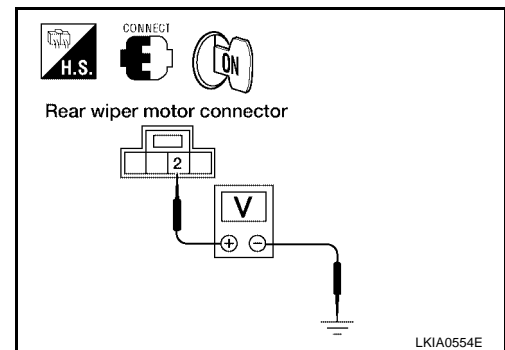

REAR WIPER AND WASHER SYSTEM

Only Rear Wiper Does Not Operate

EKS00G05

1. CHECK COMBINATION SWITCH INPUT SIGNAL

Select "BCM" on CONSULT-II. With "WIPER" data monitor, make sure "RR WIPER ON" turns ON-OFF according to operation of wiper switch.

When rear wiper switch is in : RR WIPER ON ON ON position

OK or NG

- OK >> Replace BCM. Refer to [BCS-27, "Removal and Installation"](#).
- NG >> Check the wiper switch. Refer to [BCS-3, "COMBINATION SWITCH READING FUNCTION"](#).

DATA MONITOR	
MONITOR	
RR WIPER ON	ON

SKIA4248E

Only Rear Wiper Intermittent Does Not Operate

EKS00G06

1. CHECK COMBINATION SWITCH INPUT SIGNAL

Select "BCM" on CONSULT-II. With "WIPER" data monitor, make sure "RR WIPER INT" turns ON-OFF according to operation of wiper switch.

When rear wiper switch is in : RR WIPER INT ON INT position

OK or NG

- OK >> Replace BCM. Refer to [BCS-27, "Removal and Installation"](#).
- NG >> Check the wiper switch. Refer to [BCS-3, "COMBINATION SWITCH READING FUNCTION"](#).

DATA MONITOR	
MONITOR	
RR WIPER INT	ON

SKIA4249E

Wiper Does Not Wipe When Rear Washer Operates

EKS00G07

1. CHECK COMBINATION SWITCH INPUT SIGNAL

Select "BCM" on CONSULT-II. With "WIPER" data monitor, make sure "RR WASHER SW" turns ON-OFF according to operation of rear washer switch.

When rear wiper switch is in : RR WASHER SW ON WASHER position

OK or NG

- OK >> Replace BCM. Refer to [BCS-27, "Removal and Installation"](#).
- NG >> Check the wiper switch. Refer to [BCS-3, "COMBINATION SWITCH READING FUNCTION"](#).

DATA MONITOR	
MONITOR	
RR WASHER SW	ON

SKIA4250E

A
B
C
D
E
F
G
H
I
J
L
M

WW

REAR WIPER AND WASHER SYSTEM

EKS00HJW

Removal and Installation

REAR WIPER ARM

Removal

1. Remove wiper arm cover, and remove rear wiper arm nut.
2. Remove the wiper arm.
3. Remove wiper blade.

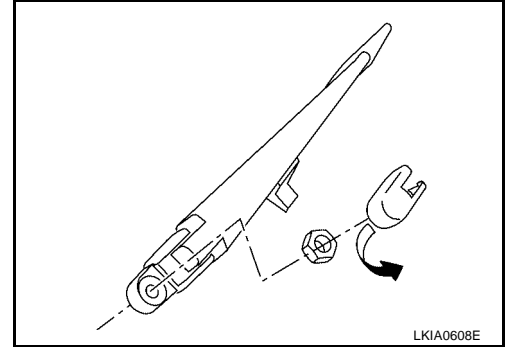

Installation

1. Operate rear wiper motor one full cycle, then turn "OFF" (Auto Stop).
2. Clean pivot area as shown. This will reduce the possibility of wiper arm looseness.

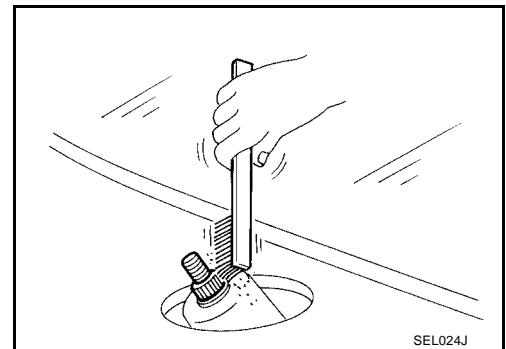

3. Install wiper blade.
4. Install wiper arm so that the arm rests in the stopper and tighten rear wiper arm nut.
5. Install wiper arm cover.

REAR WIPER AND WASHER SYSTEM

REAR WIPER MOTOR

SEC. 287

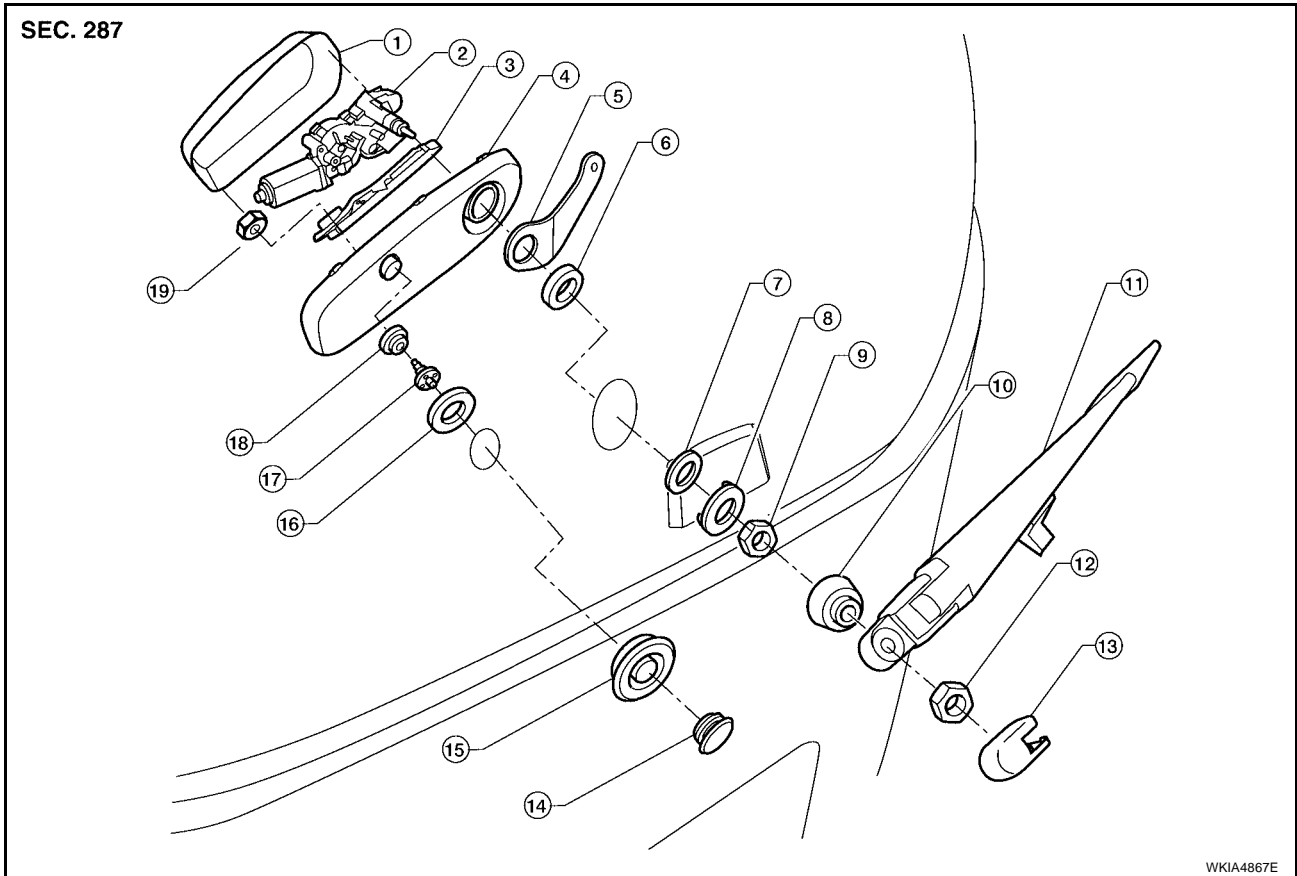

- | | | |
|--------------------------------|------------------------------|-------------------------|
| 1. Rear wiper motor cover | 2. Rear wiper motor | 3. Plate |
| 4. Rear wiper motor cover base | 5. Bracket | 6. Grommet |
| 7. Spacer | 8. Washer | 9. Rear wiper motor nut |
| 10. Pivot cap | 11. Rear wiper arm and blade | 12. Wiper arm nut |
| 13. Wiper arm cover | 14. Cap nut | 15. Gasket |
| 16. Gasket | 17. Stud | 18. Grommet |
| 19. Nut | | |

Removal

1. Remove wiper arm. Refer to [WW-42, "REAR WIPER ARM"](#).
2. Remove pivot cap.
3. Remove rear wiper motor nut.
4. Remove rear wiper motor cover.
5. Disconnect rear wiper motor connector.
6. Remove nut and remove rear wiper motor.

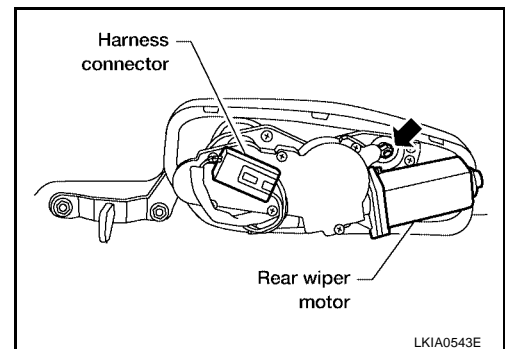

7. Remove rear wiper motor cover base.
8. Remove bracket.

REAR WIPER AND WASHER SYSTEM

Installation

CAUTION:

- Do not drop the wiper motor or cause it to contact other parts.

Installation is in the reverse order of removal.

REAR WASHER TUBE LAYOUT

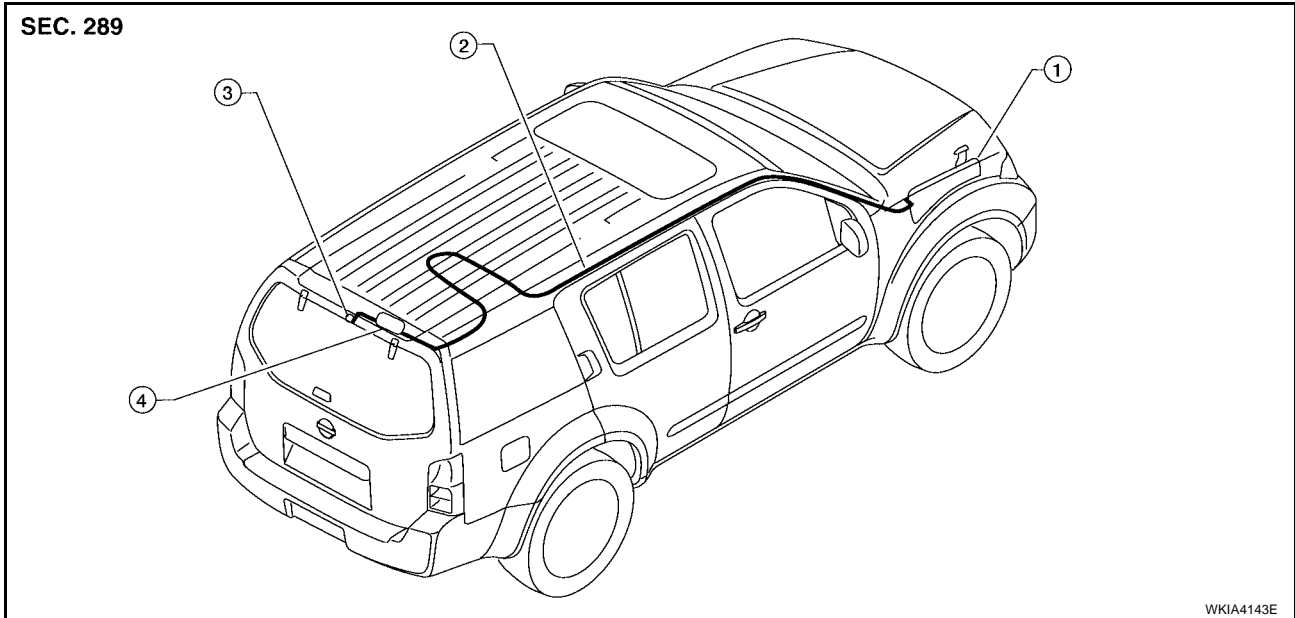

- 1 Washer fluid reservoir 2 Washer fluid tube to rear door 3 Rear washer nozzle
4 Check valve

NOTE:

Connect the check valve (2) to the washer fluid tube (1) so that the directional arrow on the check valve (2) points towards the washer nozzle tube (3).

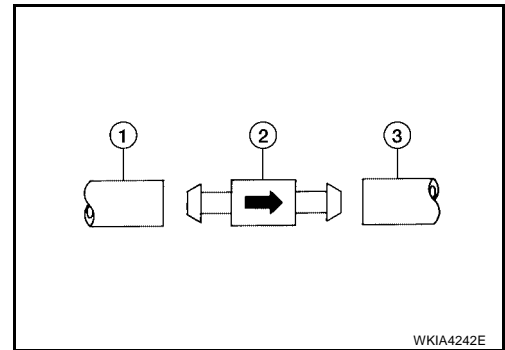

REAR WASHER NOZZLE

Removal

1. Remove the back door window garnish. Refer to [EI-35, "BACK DOOR TRIM"](#).
2. Disconnect rear washer tube from rear washer nozzle.
3. Release retaining clips and remove washer nozzle.

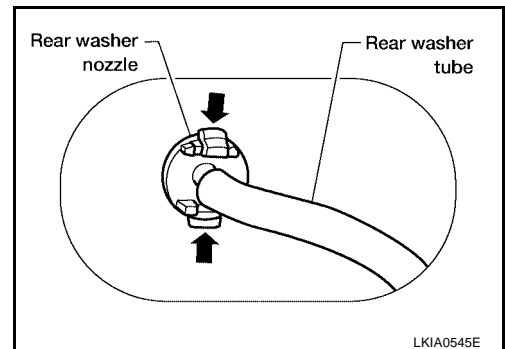

REAR WIPER AND WASHER SYSTEM

Installation

Installation is in the reverse order of removal.

NOTE:

Inspect rear washer nozzle for proper spray pattern, adjust as necessary. Refer to [WW-45, "Rear Washer Nozzle Adjustment"](#).

WASHER FLUID RESERVOIR

Refer to [WW-29, "WASHER FLUID RESERVOIR"](#).

WIPER AND WASHER SWITCH

Refer to [WW-28, "WIPER AND WASHER SWITCH"](#).

WASHER MOTOR

Refer to [WW-30, "WASHER MOTOR"](#).

Rear Washer Nozzle Adjustment

- Adjust washer nozzle with suitable tool as shown in the figure.

Adjustable range : $\pm 15^\circ$ (In any direction)

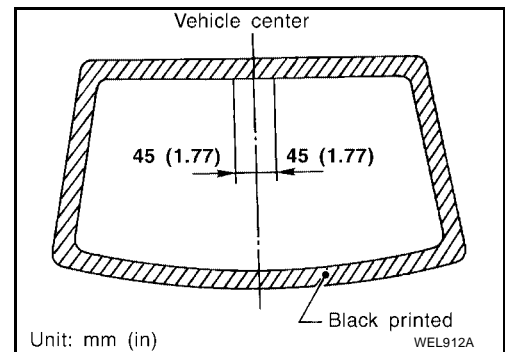
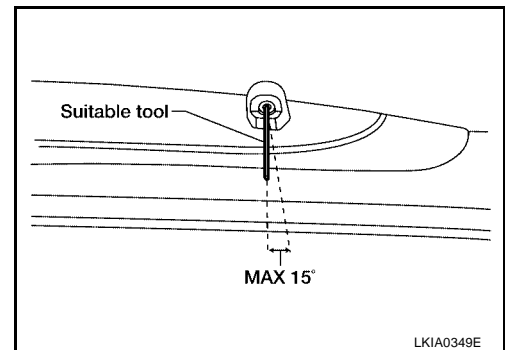

POWER SOCKET

PPF:253A2

POWER SOCKET

Wiring Diagram — P/SCKT —

EKS00G0H

WW-P/SCKT-01

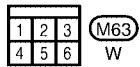
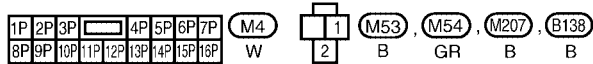
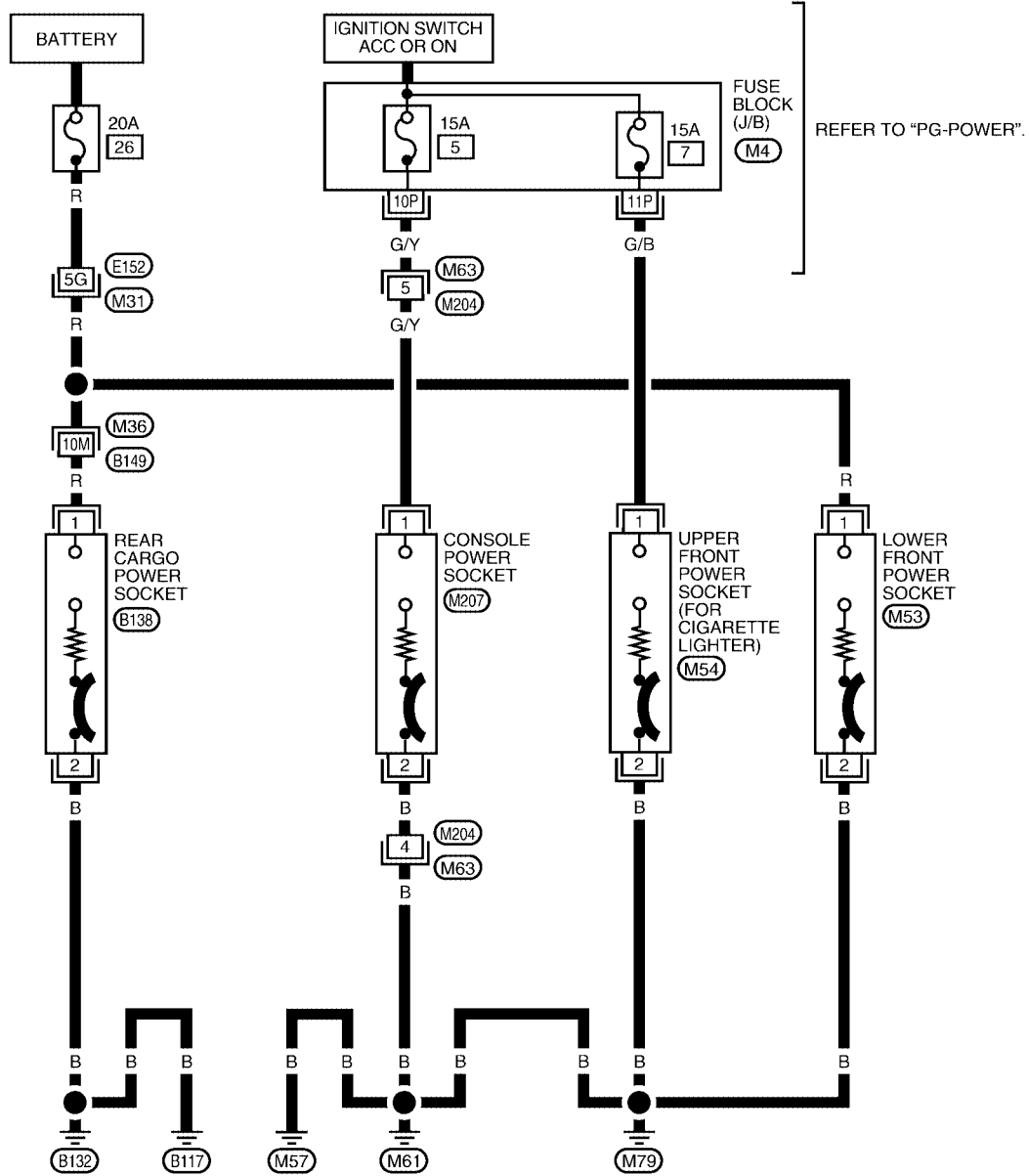

REFER TO THE FOLLOWING.
 (M31), (M36) - SUPER
 MULTIPLE JUNCTION (SMJ)

WKWA1969E

POWER SOCKET

EKS00G01

Removal and Installation

LOWER FRONT POWER SOCKET AND REAR CARGO POWER SOCKET

Removal

1. Disconnect battery negative terminal.
2. Remove inner socket from the ring, while pressing the hook on the ring out from square hole.
3. Disconnect power socket connector.
4. Remove ring from power socket finisher while pressing pawls.

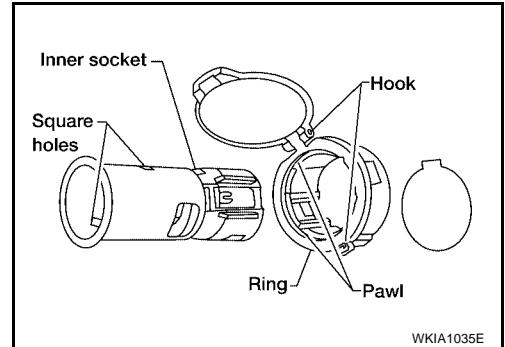

Installation

Installation is in the reverse order of removal.

UPPER FRONT POWER SOCKET (FOR CIGARETTE LIGHTER) AND CONSOLE POWER SOCKET

Removal

1. Remove inner socket from the ring, while pressing the hook on the ring out from square hole.
2. Disconnect power socket connector.
3. Remove ring from power socket finisher while pressing pawls.

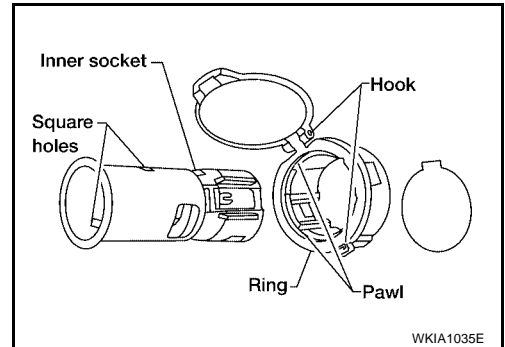

Installation

Installation is in the reverse order of removal.

A
B
C
D
E
F
G
H
I
J
L
M

WW

HORN

PFP:25610

EKS00G0J

HORN

Wiring Diagram — HORN —

WW-HORN-01

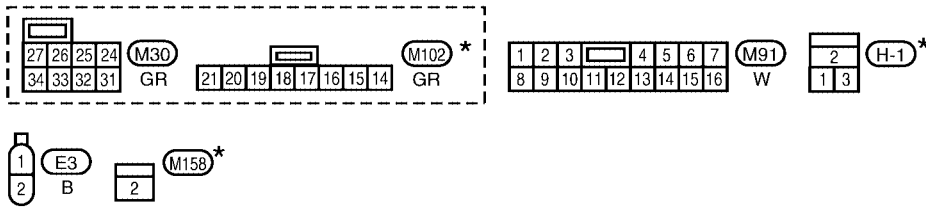
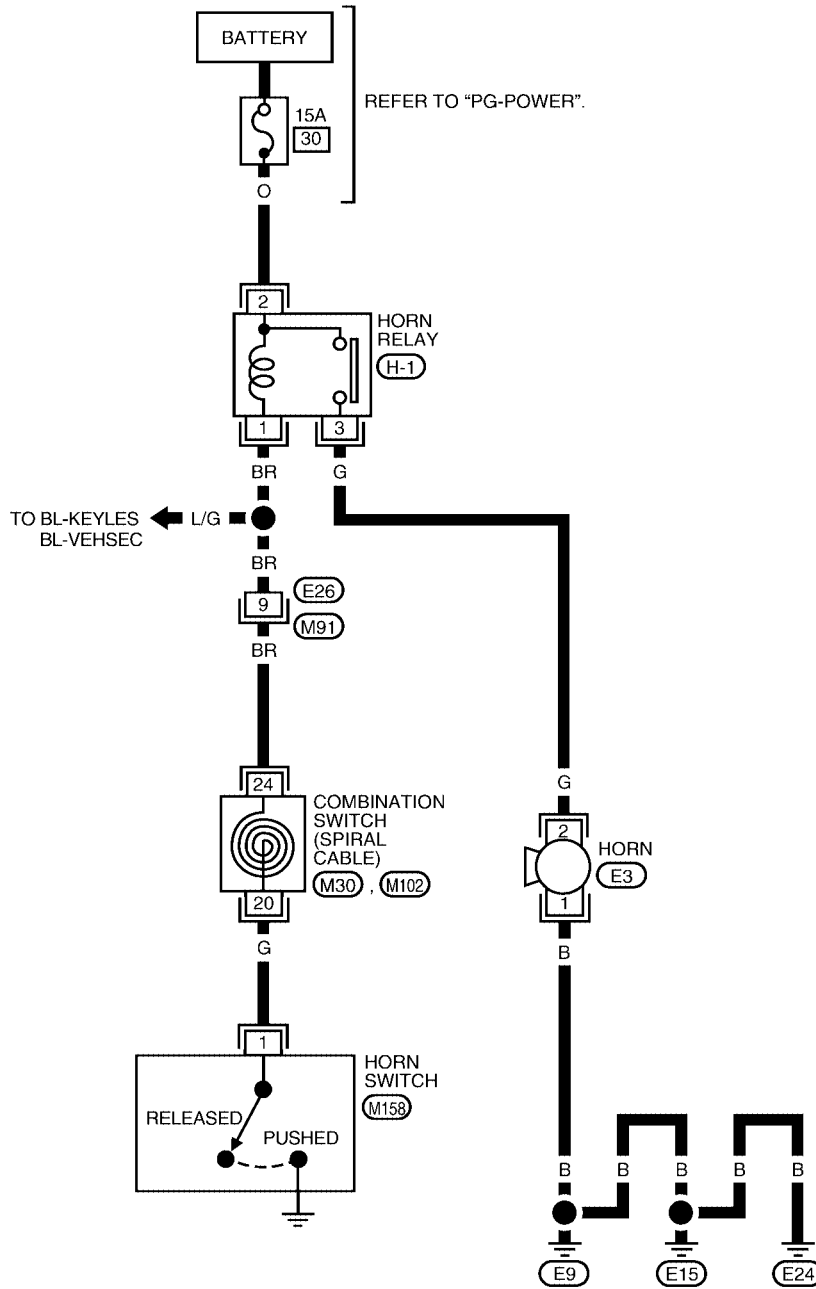

*: THIS CONNECTOR IS NOT SHOWN IN "HARNESS LAYOUT" OF PG SECTION.

WKWA4189E

HORN

Removal and Installation

REMOVAL

1. Disconnect horn connector (2).
2. Remove horn bolt (1).
3. Remove horn.

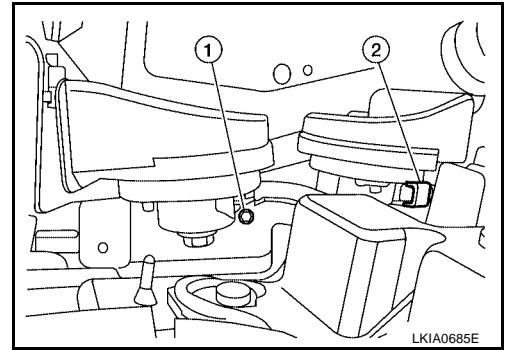

INSTALLATION

Installation is in the reverse order of removal.

EKS00G0K

A
B
C
D
E
F
G
H
I
J
L
M

WW

HORN
