

SECTION BR

CONTENTS

PRECAUTIONS AND PREPARATION	2	Removal and Installation	31
Precautions	2	Front Wheel Sensor	31
Commercial Service Tools	3	Rear Wheel Sensor	31
CHECK AND ADJUSTMENT	4	ABS Actuator	32
Checking Brake Fluid Level.....	4	Control Unit.....	34
Checking Brake Line.....	4	ABS Control Actuator Relays	34
Changing Brake Fluid	4	TROUBLE DIAGNOSES	35
AIR BLEEDING	5	How to Perform Trouble Diagnoses for Quick and Accurate Repair	35
Bleeding Procedure	5	Preliminary Check.....	36
BRAKE HYDRAULIC LINE	6	Component Parts Location and Harness Layout	37
CONTROL VALVE	8	Circuit Diagram	38
Dual Load Sensing Valve	8	Wiring Diagram –ABS–.....	39
BRAKE PEDAL AND BRACKET	11	Self-diagnosis.....	43
Removal and Installation	11	Function	43
Inspection.....	11	Self-Diagnosis Procedure	43
Adjustment	12	How To Read Self-Diagnostic Results (Malfunction codes)	44
MASTER CYLINDER	13	How To Erase Self-Diagnostic Results (Malfunction codes)	44
BRAKE BOOSTER	16	Malfunction Code/Symptom Chart	45
VACUUM HOSE	18	Ground Circuit Check	46
FRONT DISC BRAKE	19	Diagnostic Procedures.....	47
REAR DRUM BRAKE	23	Electrical Components Inspection	63
PARKING BRAKE CONTROL	27	SERVICE DATA AND SPECIFICATIONS (SDS)	64
ANTI-LOCK BRAKE SYSTEM	29		
Purpose.....	29		
Operation	29		
System Components.....	30		
System Description	30		

When you read wiring diagrams:

- Read GI section, "HOW TO READ WIRING DIAGRAMS".
- See EL section, "POWER SUPPLY ROUTING" for power distribution circuit.

When you perform trouble diagnoses, read GI section, "HOW TO FOLLOW FLOW CHART IN TROUBLE DIAGNOSES" and "HOW TO PERFORM EFFICIENT DIAGNOSIS FOR AN ELECTRICAL INCIDENT".

GI
MA
EM
LC
EC
FE
AT
FA
RA
BR
ST
RS
BT
HA
EL
IDX

PRECAUTIONS AND PREPARATION

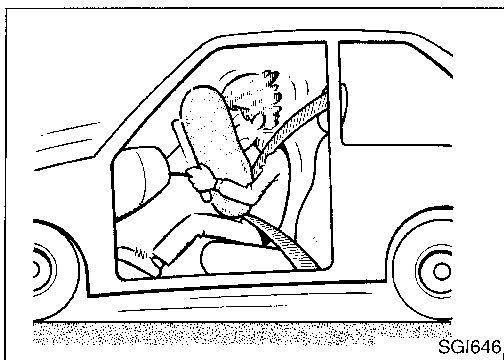

Precautions

SUPPLEMENTAL RESTRAINT SYSTEM (SRS) "AIR BAG"

The Supplemental Restraint System "Air Bag", used along with a seat belt, helps to reduce the risk or severity of injury to the driver and front passenger in a frontal collision. The Supplemental Restraint System consists of air bag modules (located in the center of the steering wheel and on the instrument panel on the passenger side), a diagnosis sensor unit, warning lamp, wiring harness and spiral cable. Information necessary to service the system safely is included in the **RS section** of this Service Manual.

WARNING:

- To avoid rendering the SRS inoperative, which could increase the risk of personal injury or death in the event of a collision which would result in air bag inflation, all maintenance must be performed by an authorized NISSAN dealer.
- Improper maintenance, including incorrect removal and installation of the SRS, can lead to personal injury caused by unintentional activation of the system.
- Do not use electrical test equipment on any circuit related to the SRS unless instructed to in this Service Manual. SRS wiring harnesses are covered with yellow insulation either just before the harness connectors or for the complete harness, for easy identification.

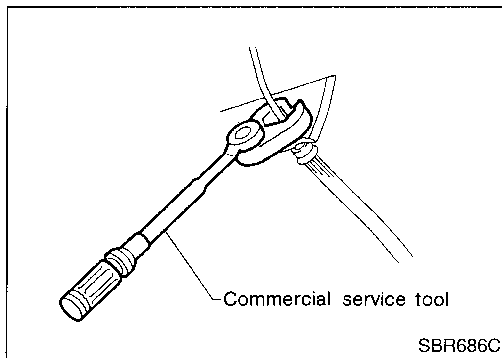

BRAKE SYSTEM

- Use brake fluid "DOT 3".
- Never reuse drained brake fluid.
- Be careful not to splash brake fluid on painted areas; it may cause paint damage. If brake fluid is splashed on painted areas, wash it away with water immediately.
- To clean master cylinder parts, disc brake caliper parts or wheel cylinder parts, use clean brake fluid.
- Never use mineral oils such as gasoline or kerosene. They will ruin rubber parts of hydraulic system.
- Use flare nut wrench when removing and installing brake tubes.
- Always torque brake lines when installing.

WARNING:

- Clean brakes with a vacuum dust collector to minimize risk of health hazard from powder caused by friction.

PRECAUTIONS AND PREPARATION

Commercial Service Tools

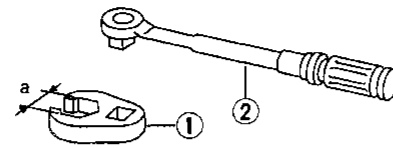
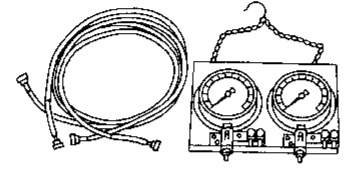
Tool name	Description	
① Flare nut crowfoot ② Torque wrench	 <p>NT360</p> <p>a: 10 mm (0.39 in)</p>	GI WA EM
Brake fluid pressure gauge	 <p>NT151</p>	LC EC FE

FE

AT

FA

RA

BR

ST

RS

BT

HA

EL

IDX

CHECK AND ADJUSTMENT

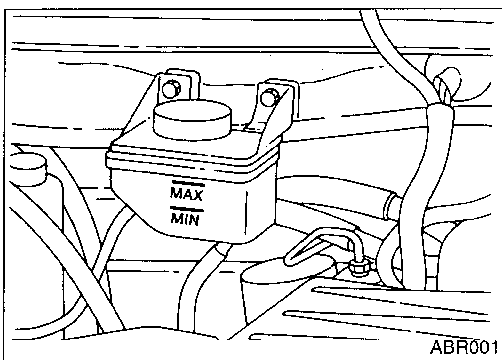

Checking Brake Fluid Level

- Check fluid level in reservoir tank. It should be between MAX and MIN lines on reservoir tank.
- If fluid level is extremely low, check brake system for leaks.
- If the brake warning lamp comes on, check brake fluid level switch and parking brake switch.

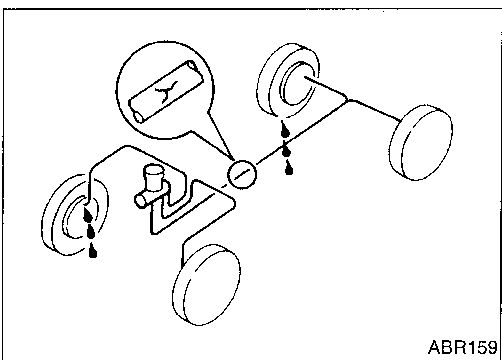

Checking Brake Line

CAUTION:

If leakage occurs around joints, retighten or, if necessary, replace damaged parts.

1. Check brake lines (tubes and hoses) for cracks, deterioration or other damage. Replace any damaged parts.
2. Check for oil leakage by fully depressing brake pedal while engine is running.

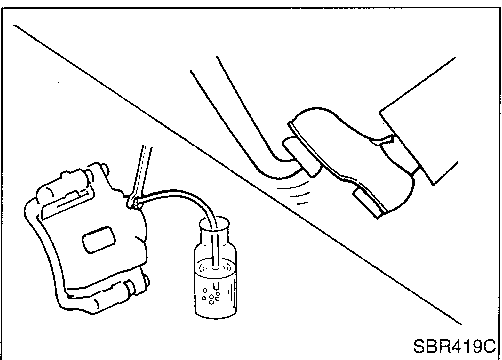

Changing Brake Fluid

CAUTION:

- Refill with new brake fluid "DOT 3".
- Always keep fluid level higher than minimum line on reservoir tank.
- Never reuse drained brake fluid.
- Be careful not to splash brake fluid on painted areas; it may cause paint damage. If brake fluid is splashed on painted areas, wash it away with water immediately.

1. Clean inside of reservoir tank, and refill with new brake fluid.
2. Connect a vinyl tube to each air bleeder valve.
3. Drain brake fluid from each air bleeder valve by depressing brake pedal.
4. Refill until new brake fluid comes out of each air bleeder valve.

Use same procedure as in bleeding hydraulic system to refill brake fluid.

Refer to "Bleeding Procedure", BR-5.

AIR BLEEDING

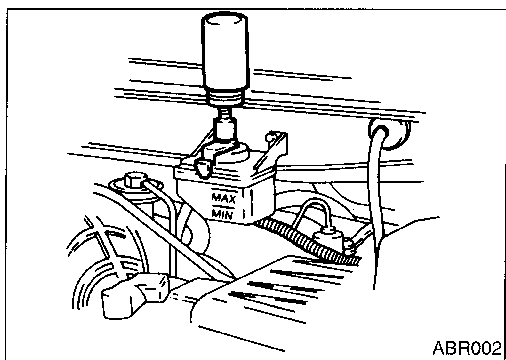

ABR002

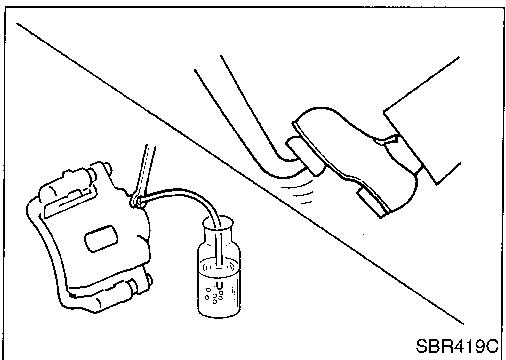

SBR419C

Bleeding Procedure

CAUTION:

- Carefully monitor brake fluid level at master cylinder during bleeding operation. GI
- Fill reservoir with new brake fluid "DOT 3". Make sure it is full at all times while bleeding air out of system. MA
- Place a container under master cylinder to avoid spillage of brake fluid. EM
- For models with ABS, turn ignition switch OFF and disconnect ABS actuator connector or battery cable. EM
- Bleed air in the following order: LC

Without ABS

Right rear brake → Left front brake → Left rear brake → Right front brake. EC

With ABS

Left front brake → Right front brake → Left rear brake → Right rear brake. FE

Turn ignition "OFF" and disconnect battery positive terminal. AT

1. Connect a transparent vinyl tube to air bleeder valve. AT
2. Fully depress brake pedal several times. FA
3. With brake pedal depressed, open air bleeder valve to release air. FA
4. Close air bleeder valve. RA
5. Release brake pedal slowly. RA
6. Repeat steps 2. through 5. until clear brake fluid comes out of air bleeder valve. RA
7. Tighten air bleeder valve. BR

: 7 - 9 N·m (0.7 - 0.9 kg-m, 61 - 78 in-lb)

BR

ST

RS

BT

HA

EL

IDX

BRAKE HYDRAULIC LINE

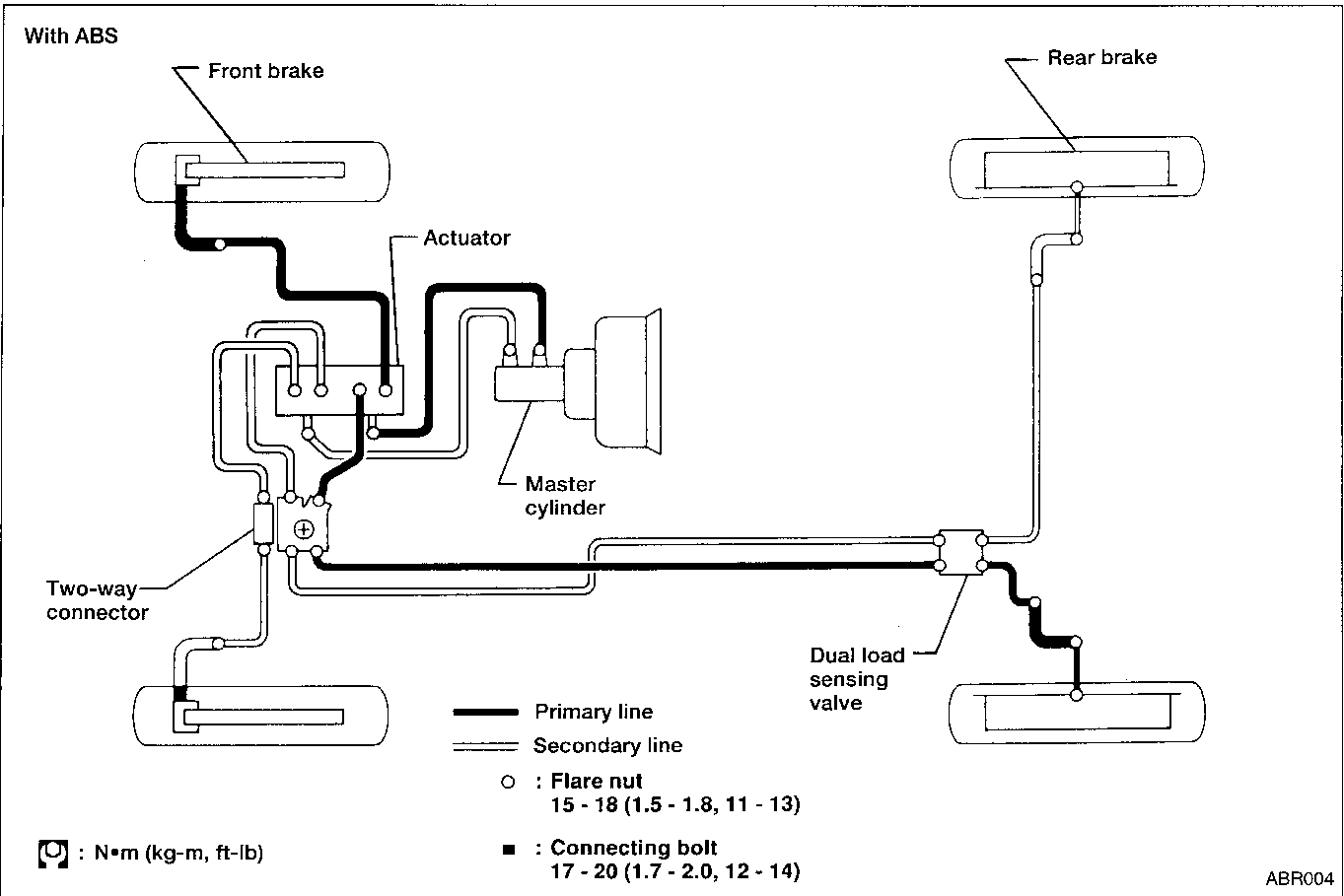
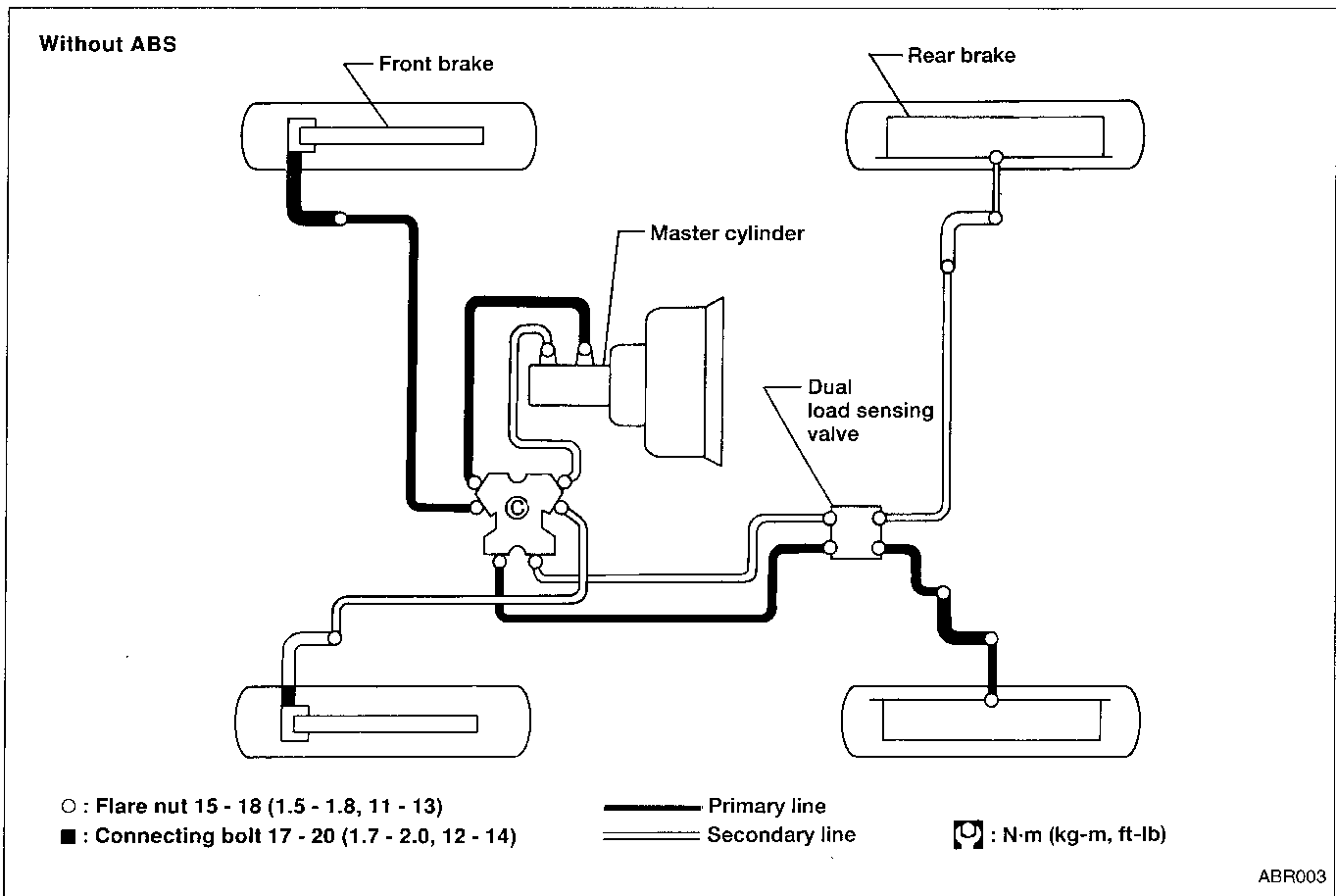

BRAKE HYDRAULIC LINE

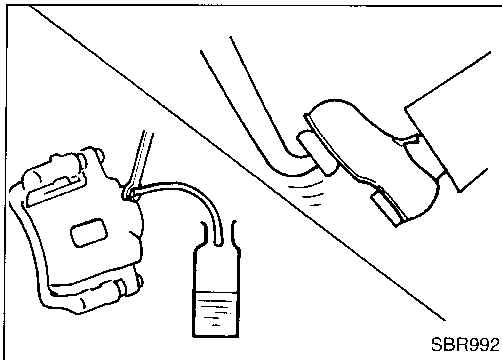

REMOVAL

CAUTION:

- Be careful not to splash brake fluid on painted areas; it may cause paint damage. If brake fluid is splashed on painted areas, wash it away with water immediately.

- All hoses must be free from excessive bending, twisting and pulling.

1. Connect a vinyl tube to air bleeder valve.
2. Drain brake fluid from each air bleeder valve by depressing brake pedal.
3. Remove flare nut securing brake tube to hose, then withdraw lock spring.
4. Cover openings to prevent entrance of dirt when disconnecting hydraulic line.

INSPECTION

Check brake lines (tubes and hoses) for cracks, deterioration or other damage. Replace any damaged parts.

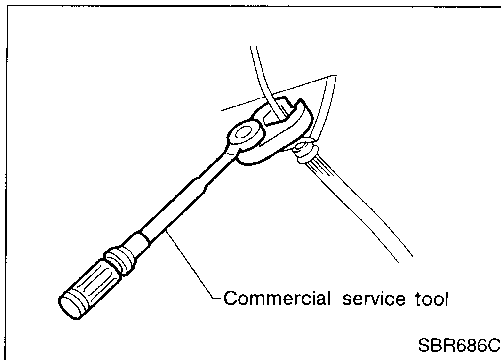

INSTALLATION

CAUTION:

- Refill with new brake fluid "DOT 3".
- Never reuse drained brake fluid.

1. Tighten all flare nuts and connecting bolts.

Flare nut:

: 15 - 18 N·m (1.5 - 1.8 kg-m, 11 - 13 ft-lb)

Connecting bolt:

: 17 - 20 N·m (1.7 - 2.0 kg-m, 12 - 14 ft-lb)

2. Refill until new brake fluid comes out of each air bleeder valve.
3. Bleed air. Refer to "Bleeding Procedure", BR-5.

CONTROL VALVE

Dual Load Sensing Valve

INSPECTION

CAUTION:

- Carefully monitor brake fluid level at master cylinder.
- Use new brake fluid "DOT 3".
- Be careful not to splash brake fluid on painted areas; it may cause paint damage. If brake fluid is splashed on paint areas, wash it away with water immediately.
- Depress pedal slowly when raising front brake pressure.
- Check rear brake pressure 2 seconds after front brake pressure reaches specified value.
- For models with ABS disconnect harness connectors from ABS actuator relay before checking.

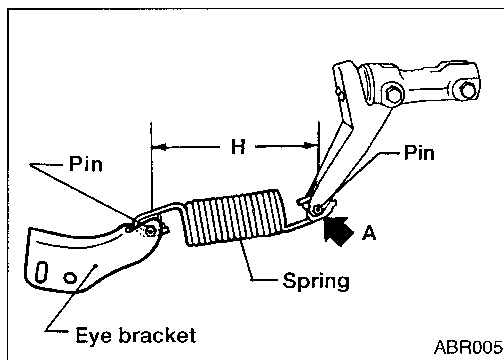

1. Check length "H" in unladen* condition.
*: Fuel, radiator coolant and engine oil full. Spare tire, jack, hand tools and mats in designated positions.
 - a. Have one person sit on the rear end. Then have the person slowly get off the vehicle. This is necessary to stabilize suspension deflection.
 - b. Measure length "H".
Length "H":
Approx. 152.5 ± 1.5 mm (6.004 ± 0.059 in)
- Adjust spring length by moving eye bracket while pushing lever toward **A**.

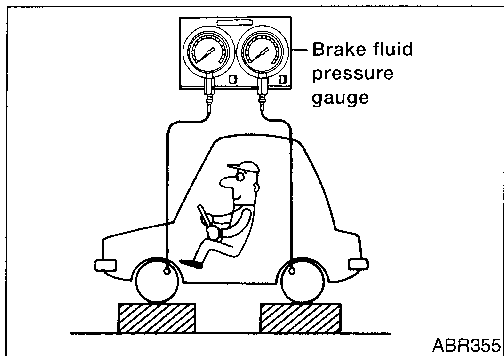

2. Connect tool to air bleeders of front and rear brakes on either LH or RH side.

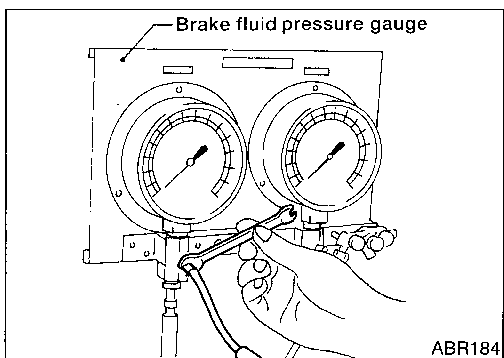

3. Bleed air from Tool.

CONTROL VALVE

Dual Load Sensing Valve (Cont'd)

4. With one person aboard, depress brake pedal until front brake fluid pressure reaches **5,884 kPa (60 kg/cm², 853 psi)**. Hold brake pedal in that position and read rear brake fluid pressure on pressure gauge indicator.
Rear brake pressure:
3,295 - 5,688 kPa
(33.6 - 58.0 kg/cm², 478 - 825 psi)
5. Depress brake pedal until front brake fluid pressure reaches **11,768 kPa (120 kg/cm², 1,706 psi)**. With brake pedal held in that position, read rear brake fluid pressure on pressure gauge indicator.
Rear brake pressure:
5,610 - 7,336 kPa
(57.2 - 74.8 kg/cm², 813 - 1,064 psi)
6. If rear brake pressure is not within specifications, replace load sensing valve with a new one. After replacement, check load sensing valve by following steps 1 through 6.

GI

MA

EM

LC

EC

FE

AT

FA

RA

BR

ST

RS

BT

HA

EL

IDX

CONTROL VALVE

Dual Load Sensing Valve (Cont'd) REMOVAL AND INSTALLATION

CAUTION:

- Refill with new brake fluid "DOT 3".
- Be careful not to splash brake fluid on painted areas; it may cause paint damage. If brake fluid is splashed on painted areas, wash it away with water immediately.
- Replace damaged Dual Load Sensing Valve as an assembly.

SEC. 462

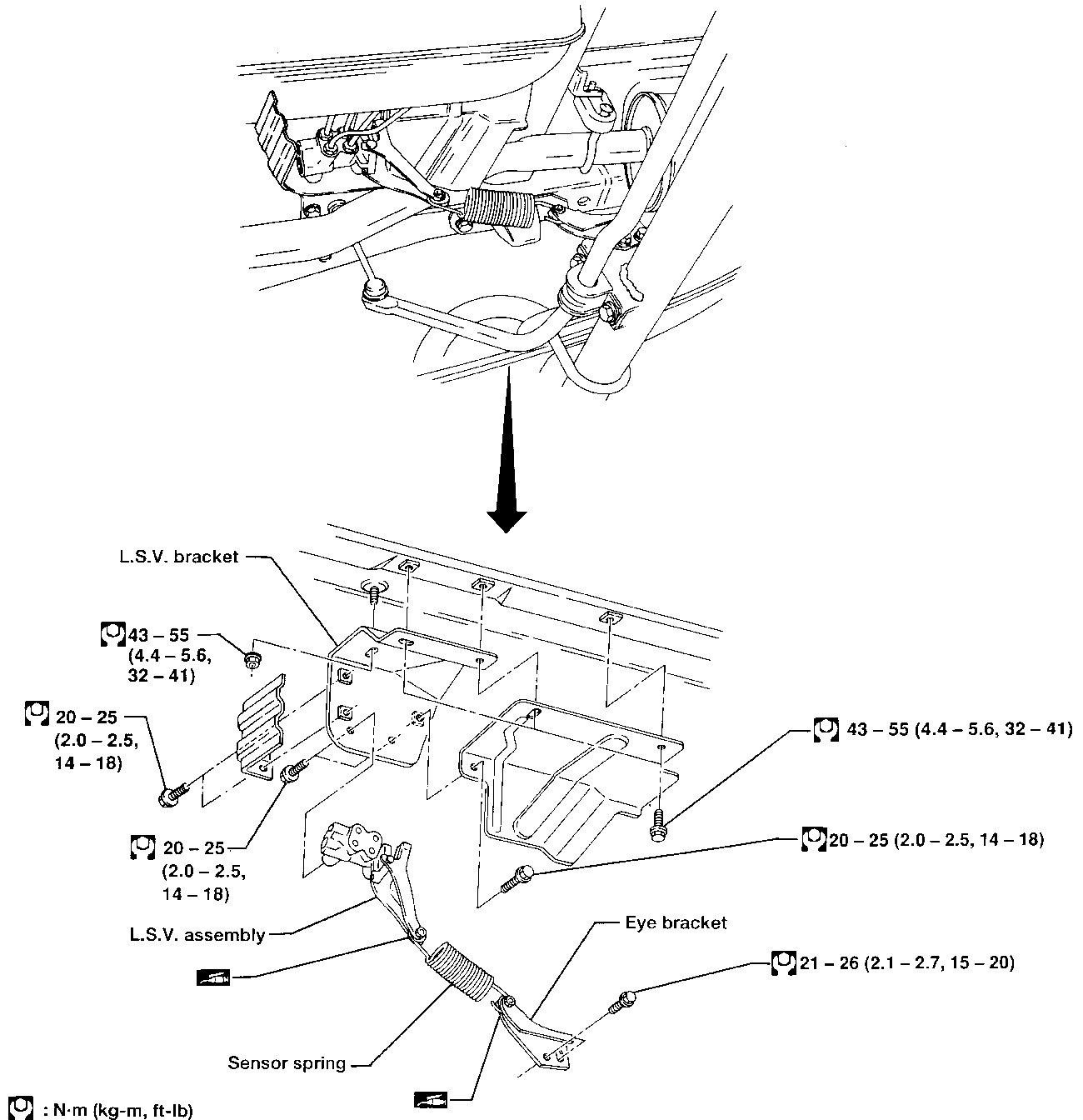

ABR342

- Tighten all flare nuts.
⊗: 15 - 18 N·m (1.5 - 1.8 kg·m, 11 - 13 ft·lb)
- Bleed air. Refer to BR-5.

BR-10

BRAKE PEDAL AND BRACKET

Removal and Installation

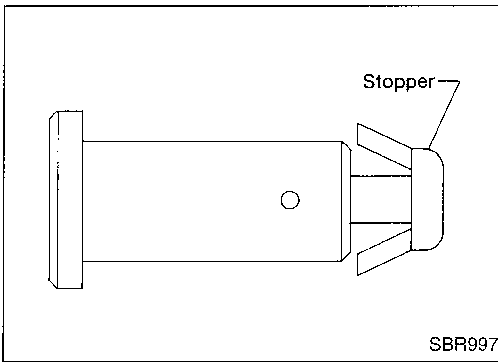
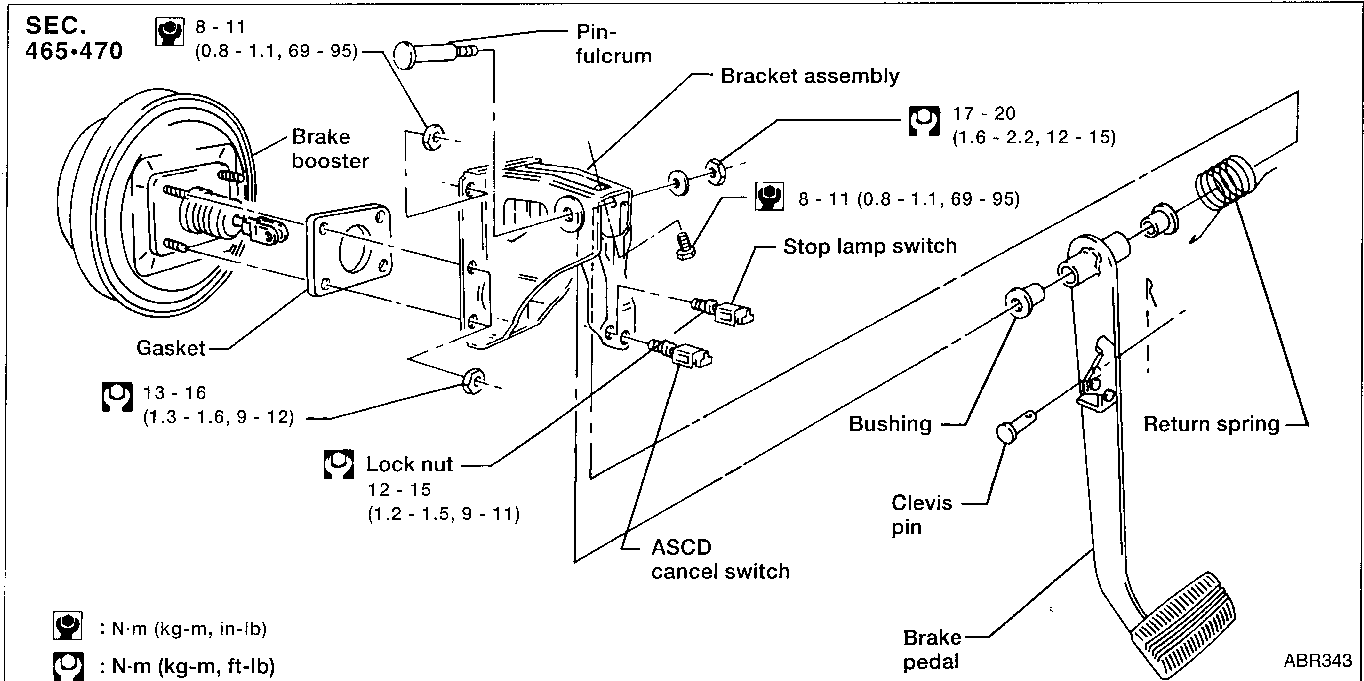

Inspection

Check brake pedal for following items.

- Brake pedal bend
- Clevis pin deformation
- Crack of any welded portion
- Crack or deformation of clevis pin stopper

GI
MA
EM
LC
EC
FE
AT
FA
BR
ST
RS
BT
HA
EL
IDX

BRAKE PEDAL AND BRACKET

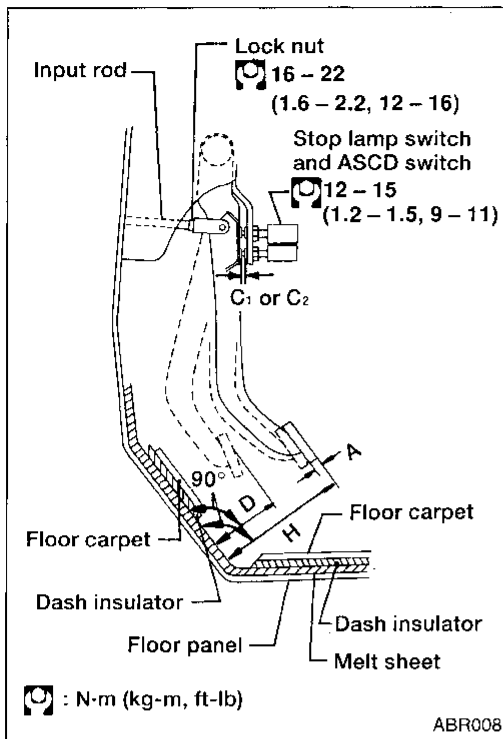

Adjustment

Check brake pedal free height from melt sheet. Adjust if necessary.

- H: Free height**
195 - 205 mm (7.68 - 8.07 in)
- D: Depressed height**
115 - 130 mm (4.53 - 5.12 in)
Under force of 490 N (50 kg, 110 lb)
with engine running
- C₁, C₂: Clearance between pedal stopper and threaded end of stop lamp switch and ASCD switch**
0.3 - 1.0 mm (0.012 - 0.039 in)
- A: Pedal free play**
1.0 - 3.0 mm (0.039 - 0.118 in)

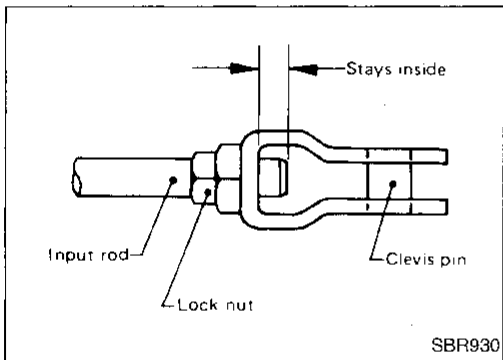

1. Loosen lock nut and adjust pedal free height by turning brake booster input rod. Then tighten lock nut.

Make sure that tip of input rod stays inside.

2. Loosen lock nut and adjust clearance "C₁" and "C₂" with stop lamp switch and ASCD switch respectively. Then tighten lock nuts.
3. Check pedal free play.

Make sure that stop lamps go off when pedal is released.

4. Check brake pedal's depressed height while engine is running.
If lower than specification, check for leaks, air in system, or damage to components (master cylinder, wheel cylinder, etc.). Then make necessary repairs.

MASTER CYLINDER

Removal

CAUTION:

- Be careful not to splash brake fluid on painted areas; it may cause paint damage. If brake fluid is splashed on painted areas, wash it away with water immediately.
- In the case of brake fluid leakage from the master cylinder, disassemble the cylinder. Then check piston cups for deformation or scratches and replace necessary parts.

1. Connect a vinyl tube to air bleeder valve.
2. Drain brake fluid from each air bleeder valve, depressing brake pedal to empty fluid from master cylinder.
3. Remove brake pipe flare nuts.
4. Remove master cylinder mounting nuts.

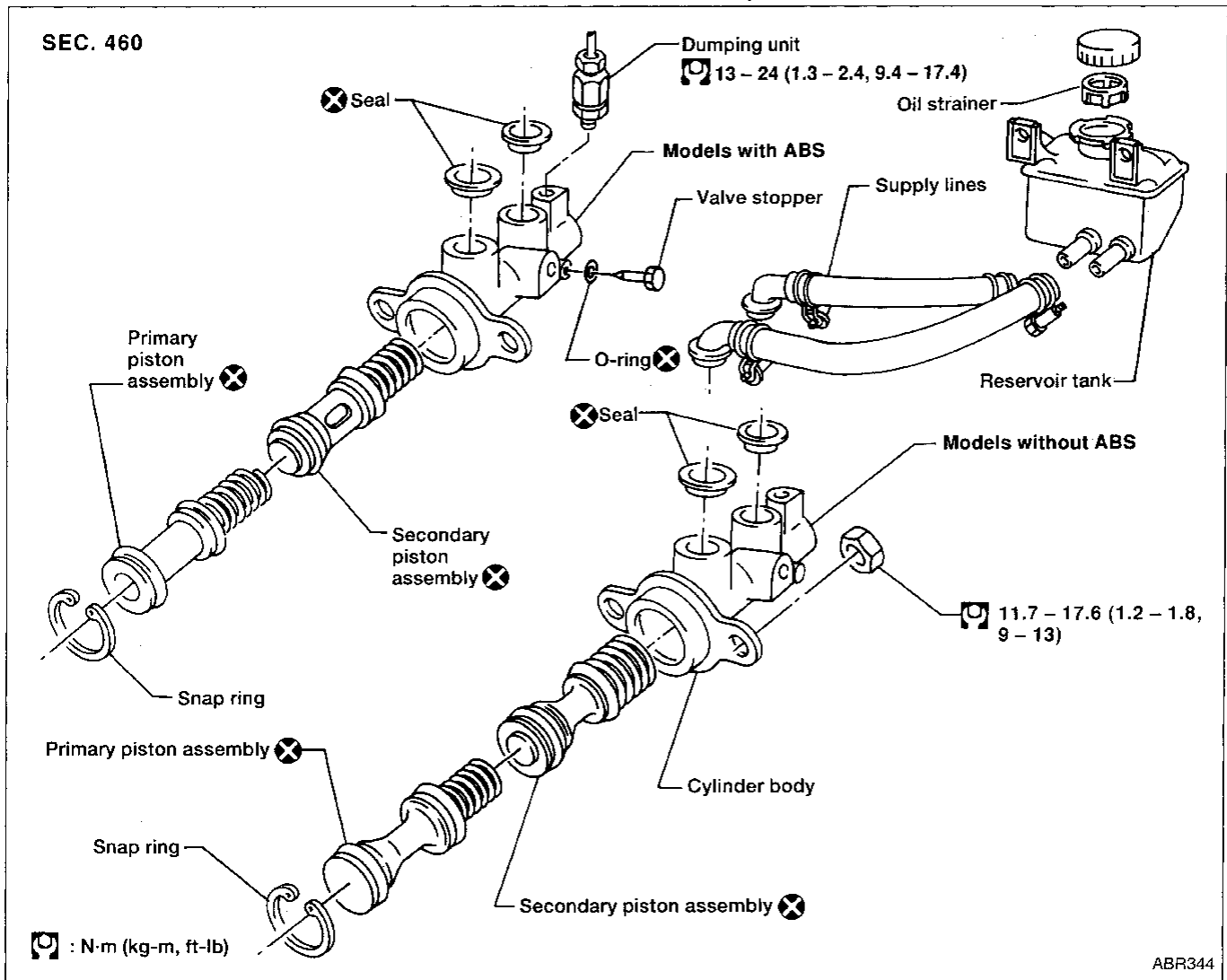

GI
MA
EM
LC
EC
FE
AT
FA
RA
BR
ST
RS
BT
HA
EL
IDX

MASTER CYLINDER

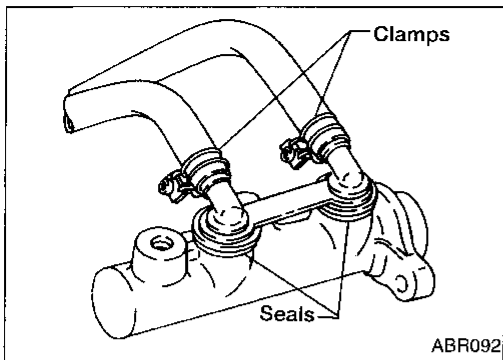

Disassembly

1. Remove rubber seals.
2. Remove clamps to supply lines.

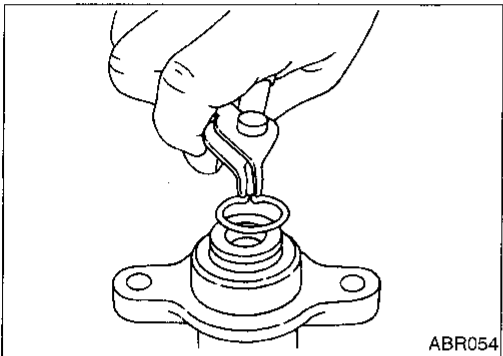

3. Remove snap ring.

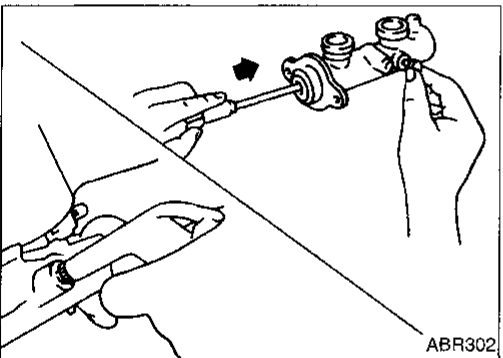

4. Remove valve stopper while piston is pushed into cylinder (Models with ABS only).

5. Remove piston assemblies.

If it is difficult to remove secondary piston assembly, gradually apply compressed air through fluid outlet.

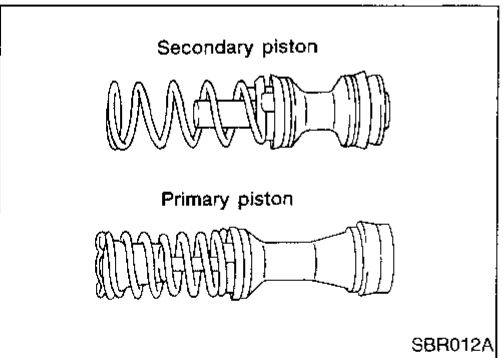

Inspection

Check master cylinder inner wall for pin holes or scratches. Replace if damaged.

Assembly

1. Insert secondary piston assembly. Then insert primary piston assembly.

- Pay attention to direction of piston cups in figure at left. Also, insert pistons squarely to avoid scratches on cylinder bore.

- Pay attention to alignment of secondary piston slit with valve stopper mounting hole of cylinder body (For models with ABS only).

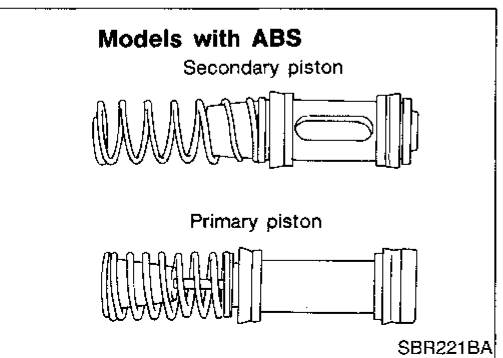

MASTER CYLINDER

Assembly (Cont'd)

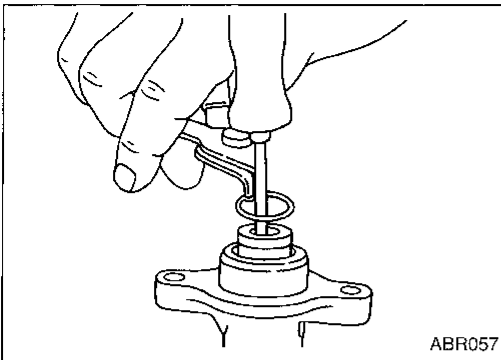

2. Install snap ring while pushing down on piston assemblies.

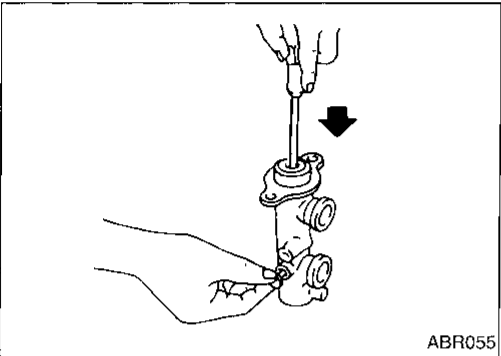

3. Install valve stopper while piston is pushed into cylinder. (Models with ABS only)
4. Install seals and supply lines to master cylinder.

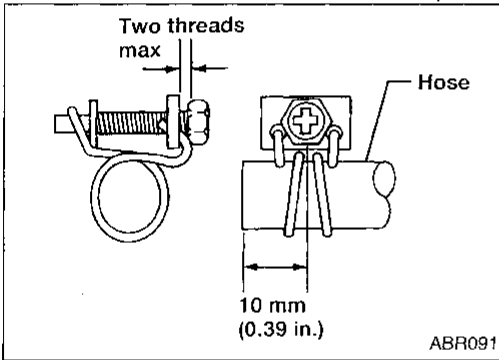

Installation

CAUTION:

- Refill with new brake fluid "DOT 3".
- Never reuse drained brake fluid.

1. Place master cylinder onto brake booster and secure mounting nuts lightly.
2. Fix flare nuts to master cylinder.
3. Tighten mounting nuts.
⚙️: 11.7 - 17.6 N·m (1.2 - 1.8 kg-m, 9 - 13 ft-lb)
4. Tighten flare nuts.
⚙️: 15 - 18 N·m (1.5 - 1.8 kg-m, 11 - 13 ft-lb)
5. Tighten all hose clamps as shown at left.
6. Bleed air. Refer to "Bleeding Procedure", BR-5.

GI

MA

EM

LC

EC

FE

AT

FA

RA

BR

ST

RS

BT

HA

EL

IDX

BRAKE BOOSTER

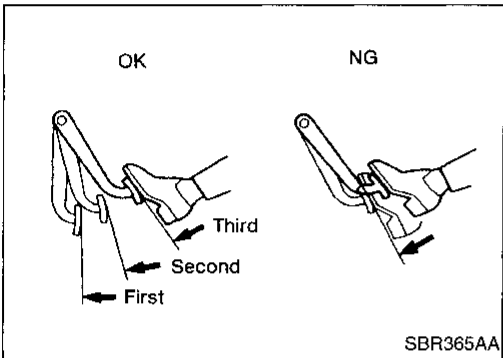
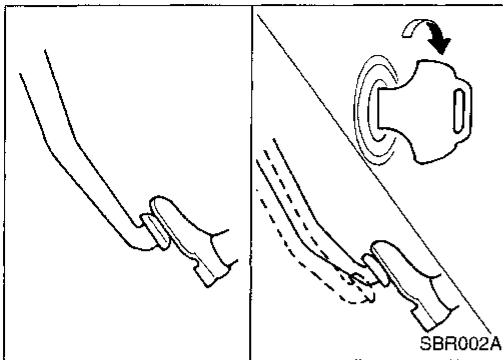

On-vehicle Service

OPERATING CHECK

- Depress brake pedal several times with engine off. After exhausting vacuum, make sure there is no change in pedal stroke.
- Depress brake pedal, then start engine. If pedal goes down slightly, operation is normal.

AIRTIGHT CHECK

- Start engine, and stop it after one or two minutes. Depress brake pedal several times slowly. Booster is airtight if pedal stroke is less each time.
- Depress brake pedal while engine is running, and stop engine with pedal depressed. The pedal stroke should not change after holding pedal down for **30 seconds**.

Removal

CAUTION:

- **Be careful not to splash brake fluid on painted areas; it may cause paint damage. If brake fluid is splashed on painted areas, wash it away with water immediately.**
- **Be careful not to deform or bend brake tubes, during removal of booster.**

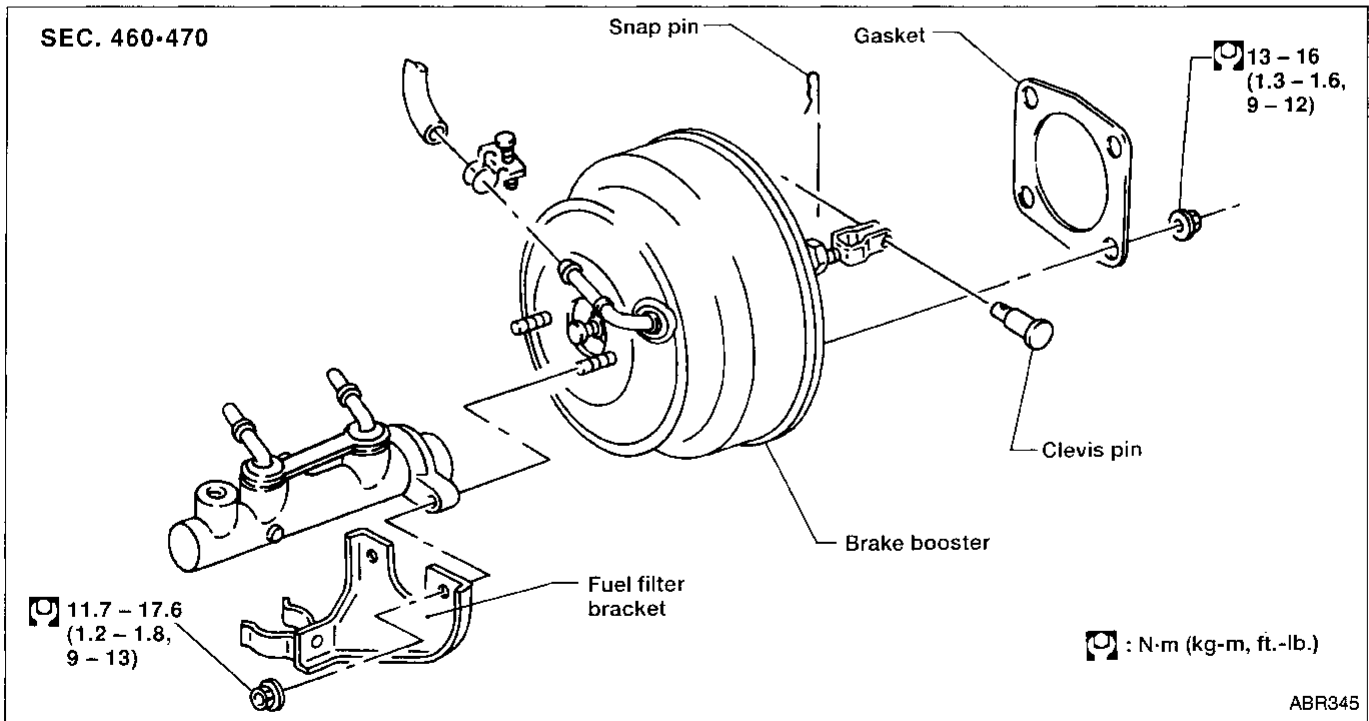

BRAKE BOOSTER

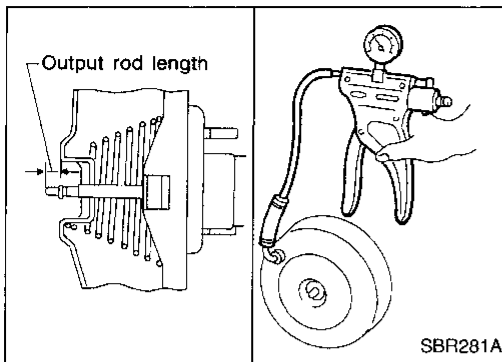

Inspection

OUTPUT ROD LENGTH CHECK

1. Apply vacuum of -66.7 kPa (-500 mmHg, -19.69 inHg) to brake booster with a hand vacuum pump.
2. Check output rod length.

Specified length:

10.275 - 10.525 mm (0.4045 - 0.4144 in)

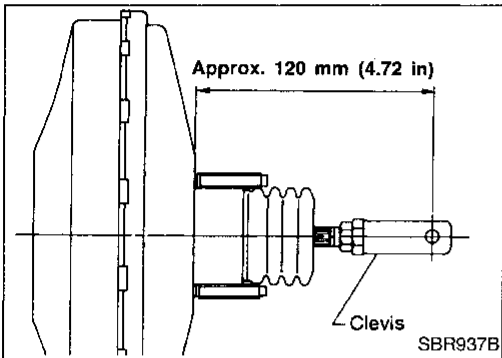

Installation

CAUTION:

- Be careful not to deform or bend brake tubes during installation of booster.
- Replace clevis pin if damaged.
- Refill with new brake fluid "DOT 3".
- Never reuse drained brake fluid.
- Take care not to damage brake booster mounting bolt thread when installing. Due to the narrow angle of installation, the threads can be damaged by the dash panel.

1. Before fitting booster, temporarily adjust clevis to dimension shown. Tighten clevis lock nut.
Ⓜ: 16 - 22 N·m (1.6 - 2.2 kg-m, 12 - 16 ft-lb)
2. Fit booster, then secure mounting nuts (brake pedal bracket to brake booster) lightly.
3. Connect brake pedal and booster input rod with clevis pin.
4. Secure mounting nuts.
Ⓜ: 13 - 16 N·m (1.3 - 1.6 kg-m, 9 - 12 ft-lb)
5. Install master cylinder. Refer to BR-13.
6. Bleed air. Refer to "Bleeding Procedure", BR-5.

GI

MA

EM

LC

EC

FE

AT

FA

RA

BR

ST

RS

BT

HA

EL

IDX

VACUUM HOSE

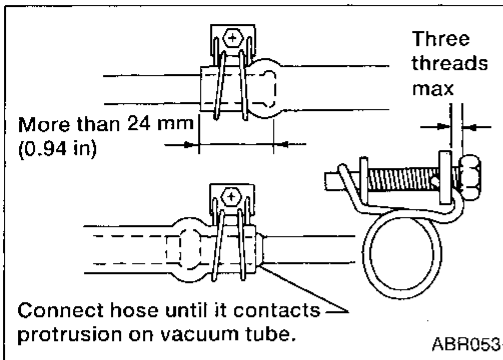

Removal and Installation

CAUTION:

When installing vacuum hoses, pay attention to the following points.

- Do not apply any oil or lubricants to vacuum hose and check valve.
- Insert vacuum tube into vacuum hose as shown.

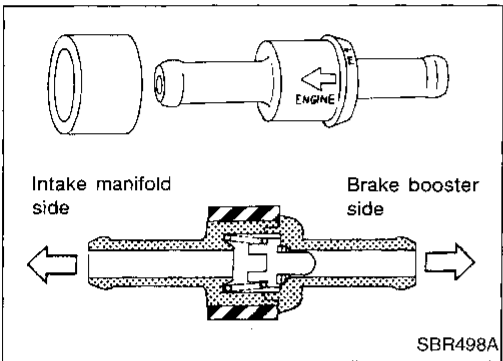

- Install check valve, paying attention to its direction.

Inspection

HOSES AND CONNECTORS

Check vacuum lines, connections and check valve for airtightness, improper attachment, chafing or deterioration.

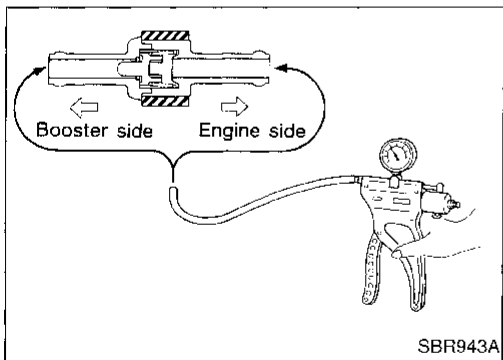

CHECK VALVE

Check vacuum with a vacuum pump.

Connect to booster side	Vacuum should exist.
Connect to engine side	Vacuum should not exist.

FRONT DISC BRAKE

Pad Replacement

WARNING:

Clean brake pads with a vacuum dust collector to minimize the hazard of airborne particles or other materials.

CAUTION:

- When cylinder body is open, do not depress brake pedal or caliper piston will pop out.
- Be careful not to damage piston boot or get oil on rotor.
- Suspend cylinder body with wire so as not to stretch brake hose.

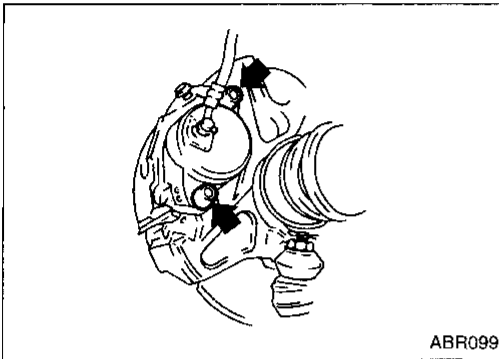

1. Remove master cylinder reservoir cap.
2. Remove two pin bolts.

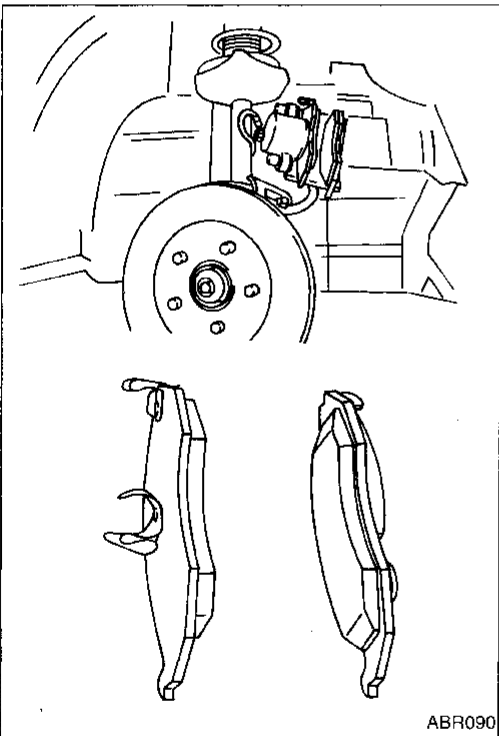

3. Lift cylinder body off rotor. Then replace pads.

Standard pad thickness:

9.67 mm (0.3807 in)

Pad wear limit:

2.0 mm (0.079 in)

Carefully monitor brake fluid level because brake fluid will return to reservoir when pushing back piston.

GI

MA

EM

LC

EC

FE

AT

FA

RA

BR

ST

RS

BT

HA

EL

IDX

FRONT DISC BRAKE

SEC. 440

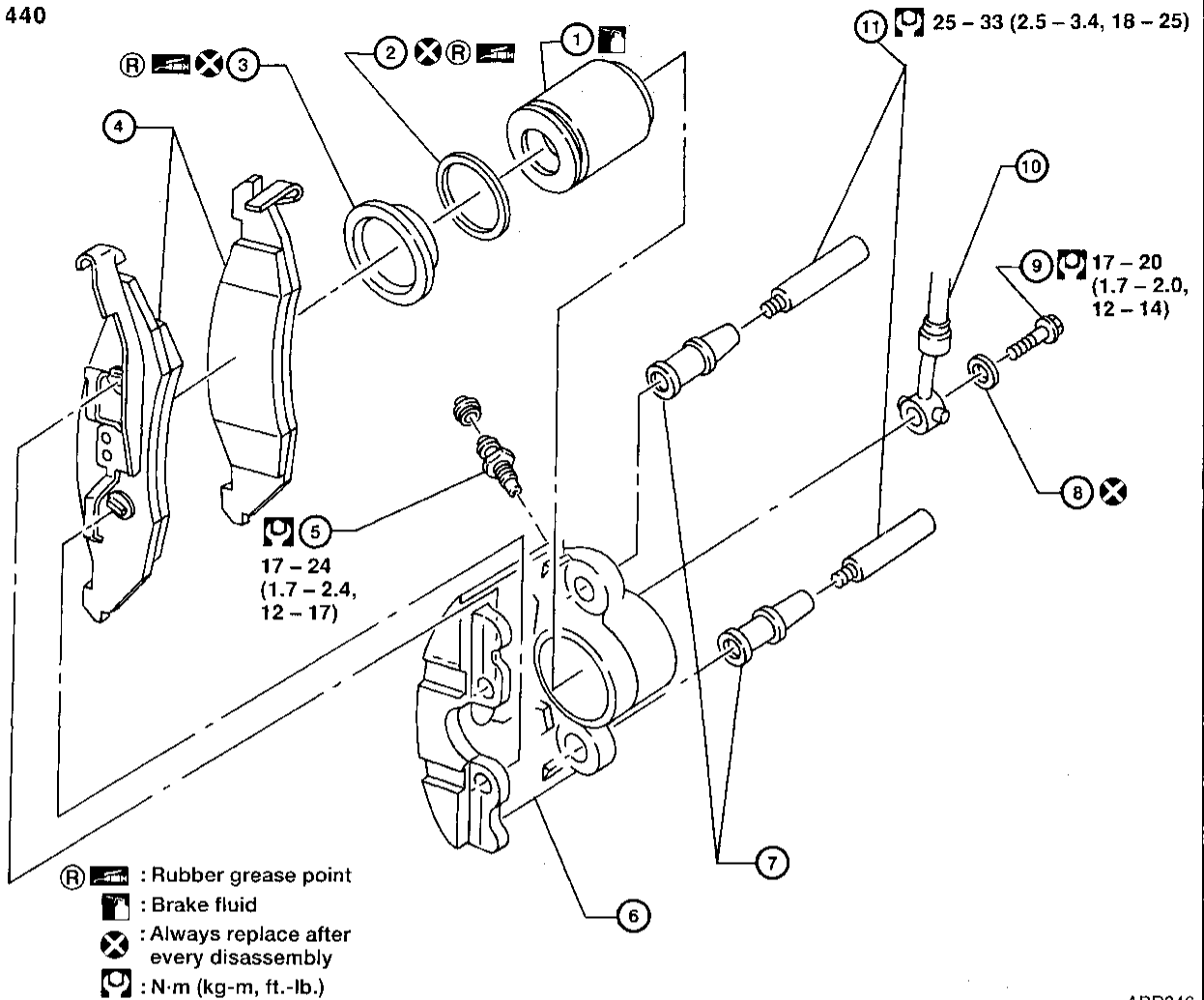

ABR346

- ① Piston
- ② Piston seal
- ③ Dust seal
- ④ Pad

- ⑤ Air bleeder
- ⑥ Cylinder body
- ⑦ Pin boot
- ⑧ Copper washer

- ⑨ Connecting bolt
- ⑩ Brake hose
- ⑪ Main pin bolt

FRONT DISC BRAKE

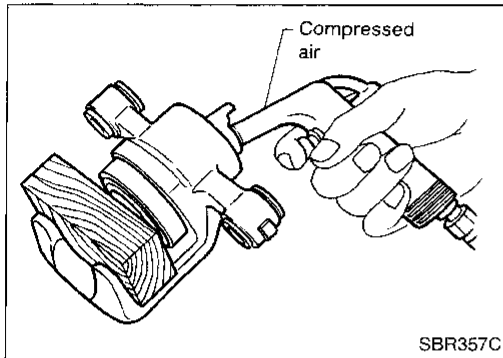
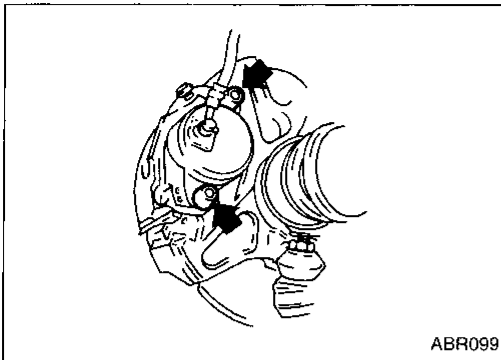

Removal

WARNING:

Clean brake pads with a vacuum dust collector to minimize the hazard of airborne particles or other materials.

CAUTION:

Suspend caliper assembly with wire so as not to stretch brake hose.

Remove pin bolts.

It is not necessary to remove connecting bolt except for disassembly or replacement of caliper assembly. In this case, suspend caliper assembly with wire so as not to stretch brake hose.

Disassembly

WARNING:

Do not place your fingers in front of piston.

CAUTION:

- Do not scratch or score cylinder wall.
- Do not pry directly against plastic piston when removing it from cylinder.

1. Push out piston and dust seal with compressed air.
2. Remove piston seal with a suitable tool.

Inspection — Caliper

CYLINDER BODY

- Check inside surface of cylinder for score, rust, wear, damage or presence of foreign objects. If any of the above conditions are observed, replace cylinder body.
- Minor damage from rust or foreign objects may be eliminated by polishing surface with a fine emery paper. Replace cylinder body if necessary.

CAUTION:

Use brake fluid to clean. Never use mineral oil.

PISTON

Check piston for score, rust, wear, damage or presence of foreign objects. Replace if any of the above conditions are observed.

CAUTION:

Piston sliding surface is plastic. Do not polish with emery paper even if rust or foreign objects are stuck to sliding surface.

SLIDE PIN, PIN BOLT AND PIN BOOT

Check for wear, cracks or other damage. Replace if any of the above conditions are observed.

GI

MA

EM

LC

EC

FE

AT

FA

RA

BR

ST

RS

BT

HA

EL

IDX

FRONT DISC BRAKE

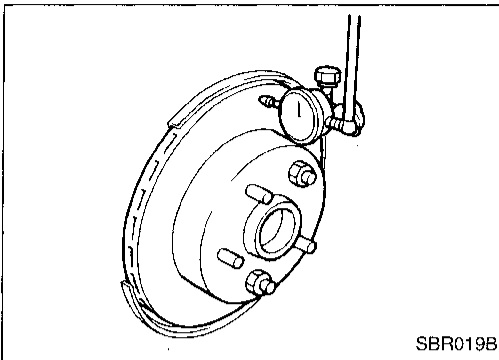

Inspection — Rotor

RUNOUT

1. Secure rotor to wheel hub with at least two nuts (M12 x 1.25).
2. Check runout using a dial indicator.

Make sure that wheel bearing axial end play is within the specifications before measuring. Refer to FA section (“Front Wheel Bearing”, “ON-VEHICLE SERVICE”).

Maximum runout:

0.07 mm (0.0028 in)

3. If the runout is out of specification, find minimum runout position as follows:
 - a. Remove nuts and rotor from wheel hub.
 - b. Shift the rotor one hole and secure rotor to wheel hub with nuts.
 - c. Measure runout.
 - d. Repeat steps a through c so that minimum runout position can be found.
4. If the runout is still out of specification, turn rotor with on-car brake lathe (“MAD, DL-8700”, “AMMCO 700 and 705” or equivalent).

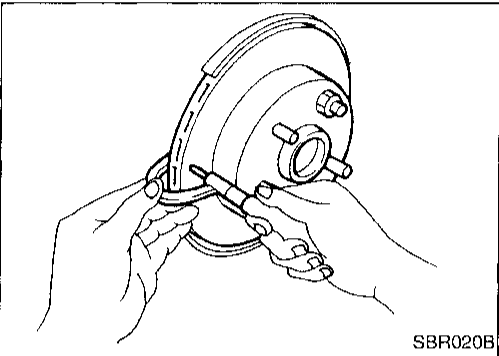

THICKNESS

Thickness variation (At least 8 positions):

Maximum 0.01 mm (0.0004 in)

If thickness variation exceeds the specification, turn rotor with on-car brake lathe.

Rotor repair limit:

Minimum thickness

24.0 mm (0.945 in)

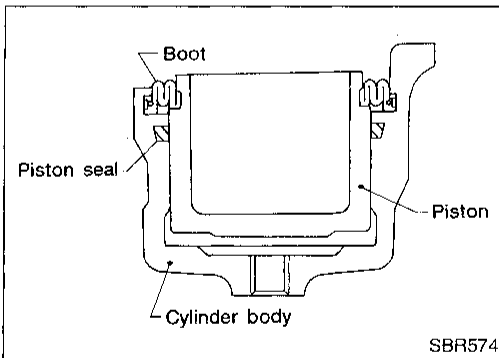

Assembly

1. Insert piston seal into groove on cylinder body.
2. With piston boot fitted to piston, insert piston boot into groove on cylinder body and install piston.
3. Properly secure piston boot.

Installation

CAUTION:

- Refill with new brake fluid “DOT 3”.
- Never reuse drained brake fluid.

1. Install caliper assembly.
2. Install brake hose to caliper securely.
3. Install all parts and secure all bolts.
4. Bleed air. Refer to “Bleeding Procedure”, BR-5.

REAR DRUM BRAKE

SEC. 441

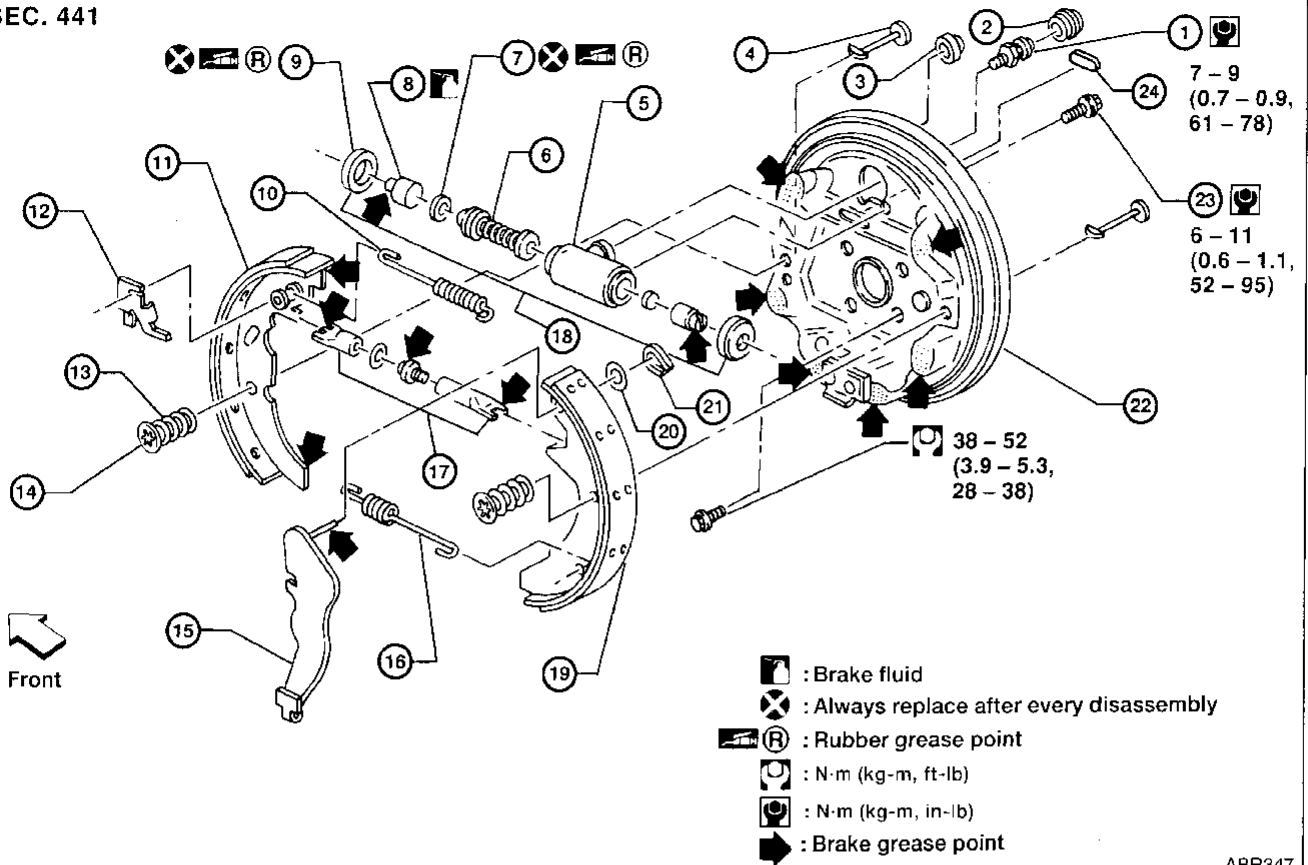

ABR347

- | | | |
|-----------------------------|-------------------------|-----------------------|
| ① Air bleeder | ⑨ Dust cover | ⑰ Adjuster |
| ② Air bleeder cap | ⑩ Adjuster spring | ⑱ Wheel cylinder |
| ③ Shoe inspection hole plug | ⑪ Shoe | ⑲ Shoe |
| ④ Shoe hold-down pin | ⑫ Adjusting lever | ⑳ Washer |
| ⑤ Cylinder body | ⑬ Shoe hold-down spring | ㉑ Retainer ring |
| ⑥ Spring | ⑭ Retainer | ㉒ Back plate |
| ⑦ Piston cap | ⑮ Toggle lever | ㉓ Wheel cylinder bolt |
| ⑧ Piston | ⑯ Return spring | ㉔ Adjuster plug |

GI
MA
EM
LC
EC
FE
AT
FA
RA

BR

ST

RS

BT

HA

EL

IDX

REAR DRUM BRAKE

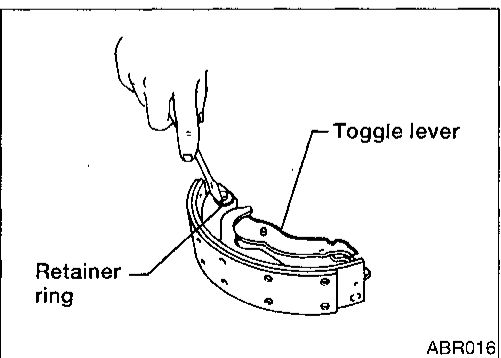
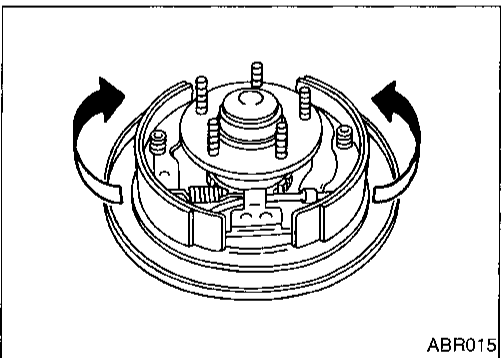
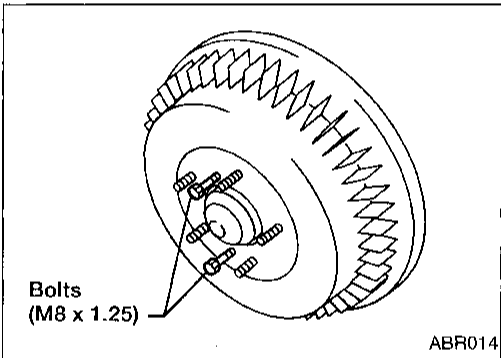
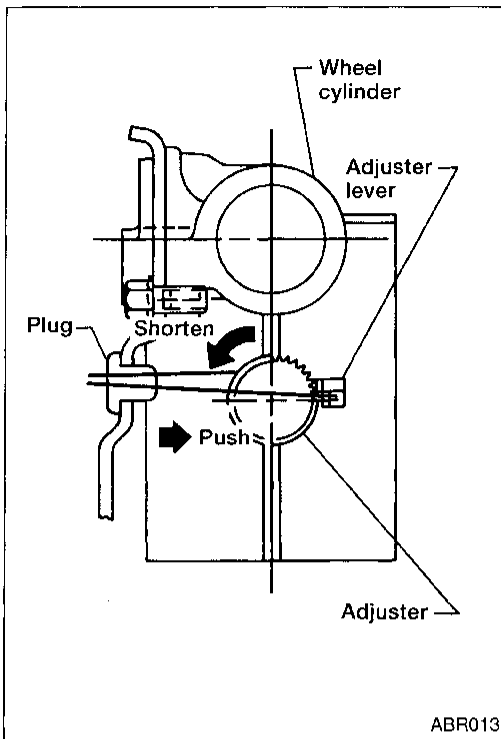

Removal

WARNING:

Clean brake lining with a vacuum dust collector to minimize the hazard of airborne materials.

CAUTION:

Make sure parking brake lever is completely released.

1. Release parking brake lever fully, then remove drum.
- If drum is hard to remove, the following procedures should be carried out.
- a. Remove adjuster plug. Shorten adjuster as shown to make clearance between brake shoe and drum.

- b. Install two bolts as shown. Tighten the two bolts gradually.

2. After removing retainer, remove spring by rotating shoes. **Be careful not to damage parking brake cable when separating it.**

3. Remove adjuster.
4. Disconnect parking brake cable from toggle lever.

5. Remove retainer ring with a suitable tool. Then separate toggle lever and brake shoe.

REAR DRUM BRAKE

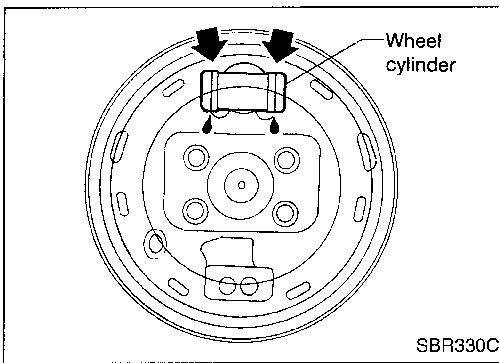

Inspection — Wheel Cylinder

- Check wheel cylinder for leakage.
- Check for wear, damage and loose conditions. Replace if any such condition exists.

GI

MA

EM

LC

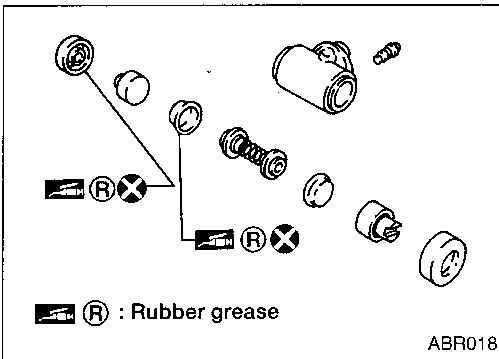

Wheel Cylinder Overhaul

- Check all internal parts for wear, rust and damage. Replace if necessary.
- Be careful not to scratch cylinder when installing pistons.

EC

FE

AT

FA

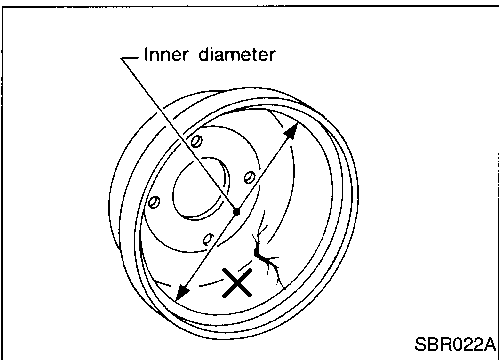

Inspection — Drum

Maximum inner diameter:
251.5 mm (9.90 in)

Out-of-roundness:
0.015 mm (0.0006 in) or less

- Contact surface should be fine finished with No. 120 to 150 emery paper.
- Using a drum lathe, resurface brake drum if it shows score, partial wear or stepped wear.
- After brake drum has been completely reconditioned or replaced, check drum and shoes for proper contact pattern.

RA

BR

ST

RS

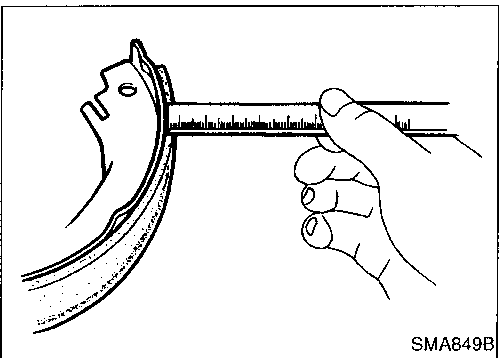

Inspection — Lining

Check lining thickness.

Standard lining thickness:
5.9 mm (0.232 in)

Lining wear limit:
2.0 mm (0.079 in)

BT

HA

EL

IDX

REAR DRUM BRAKE

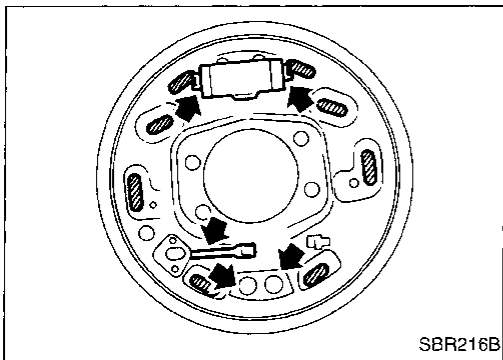

SBR216B

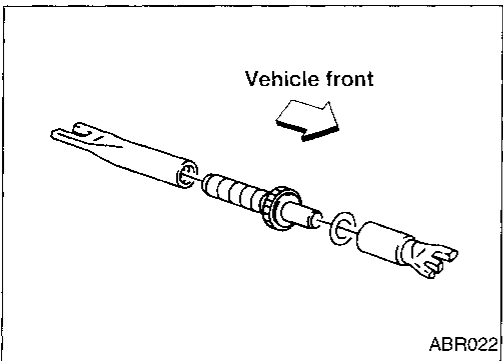

ABR022

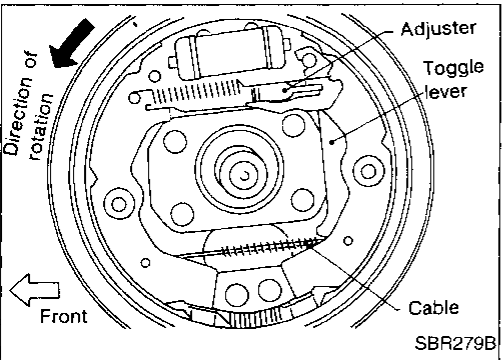

SBR279B

Installation

Always perform shoe clearance adjustment. Refer to BR-28.

1. Fit toggle lever to brake shoe with retainer ring.
2. Apply brake grease to the contact areas shown at left.

3. Shorten adjuster by rotating it.
 - Pay attention to direction of adjuster.

Wheel	Screw
Left	Left-hand thread
Right	Right-hand thread

4. Connect parking brake cable to toggle lever.
5. Install all parts.

Be careful not to damage wheel cylinder piston boots.

6. Check that all parts are installed properly.
 - Pay attention to direction of adjuster assembly.**
7. Install brake drum.
8. When installing new wheel cylinder or overhauling wheel cylinder, bleed air. Refer to "Bleeding Procedure", BR-5.
9. Adjust parking brake. Refer to BR-28.

PARKING BRAKE CONTROL

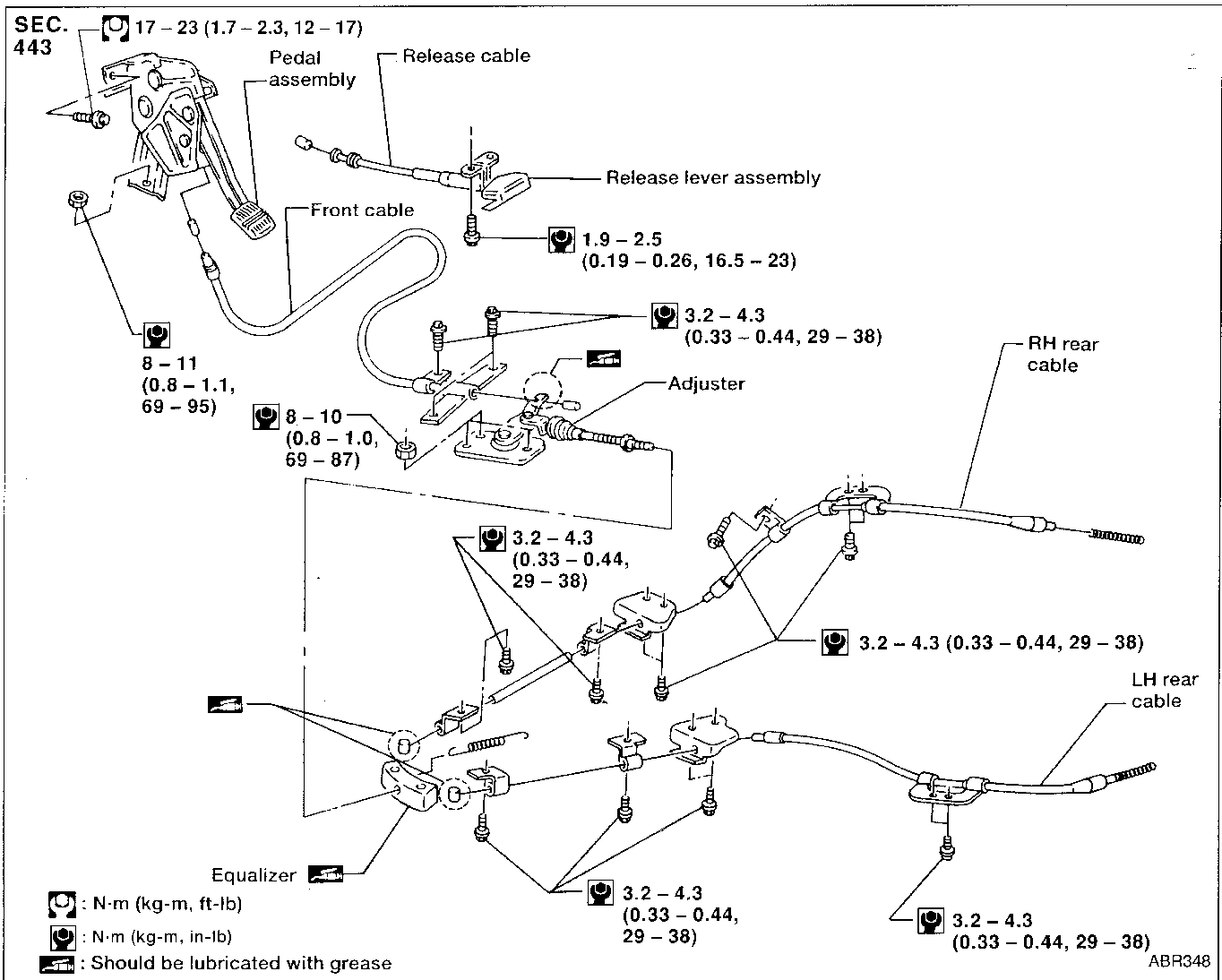

Removal and Installation

- Parking brake cables can be removed without removing pedal assembly.
- In order to access front cable, remove center console, then pull carpet back.

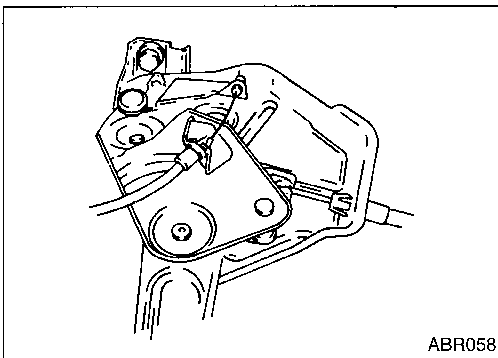

- The figure at left shows how front and release cables are connected to pedal assembly.

PARKING BRAKE CONTROL

Inspection

1. Check pedal assembly for wear or other damage. Replace if necessary.
2. Check wires for discontinuity or deterioration. Replace if necessary.
3. Check parking brake switch and warning lamp. Warning lamp should come on when depressing pedal one notch. Replace if necessary.
4. Check parts at each connecting portion and, if found deformed or damaged, replace.

Adjustment

- Before adjustment, to adjust clearance between shoe and drum correctly, depress service brake pedal several times until clicking sound from rear brake is not present.
- After adjustment, make sure that there is no drag when parking brake pedal is released.

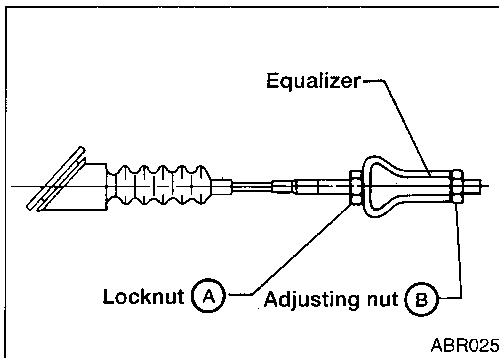

1. Loosen lock nut (A), rotate adjusting nut (B).
2. Tighten lock nut (A) and adjusting nut (B).
⚙️: 7.8 - 9.8 N·m (0.8 - 1.0 kg·m, 69 - 87 in-lb)

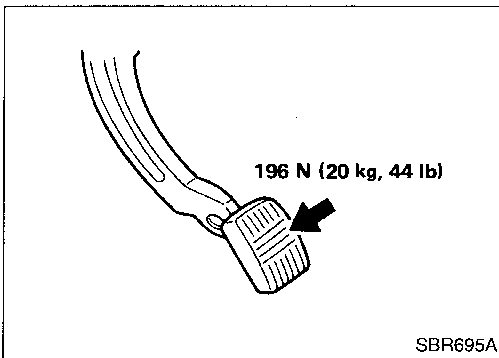

3. Depress parking brake pedal with specified amount of force. Check pedal stroke and ensure smooth operation.
Number of notches:
11 - 12

ANTI-LOCK BRAKE SYSTEM

Purpose

The Anti-Lock Brake System (ABS) consists of electronic and hydraulic components. It controls braking force so locking of the wheels can be avoided.

The ABS:

- 1) Improves proper tracking performance through steering wheel operation.
- 2) Eases obstacle avoidance through steering wheel operation.
- 3) Improves vehicle stability.

Operation

- When the vehicle speed is less than 10 km/h (6 MPH) this system does not work.
- The Anti-Lock Brake System (ABS) has self-test capabilities. The system turns on the ABS warning lamp for 1 second each time the ignition switch is turned "ON". After the engine is started, the ABS warning lamp turns off. The system performs a test the first time the vehicle reaches 6 km/h (4 MPH). A mechanical noise may be heard as the ABS performs this self-test. This is a normal part of the self-test feature. If a malfunction is found during this check, the ABS warning lamp will stay on.
- While driving, a mechanical noise may be heard and slight pedal pulsation may be felt during ABS operation. This is a normal condition.

GI

MA

EM

LC

EC

FE

AT

FA

RA

BR

ST

RS

BT

HA

EL

IDX

ANTI-LOCK BRAKE SYSTEM

System Components

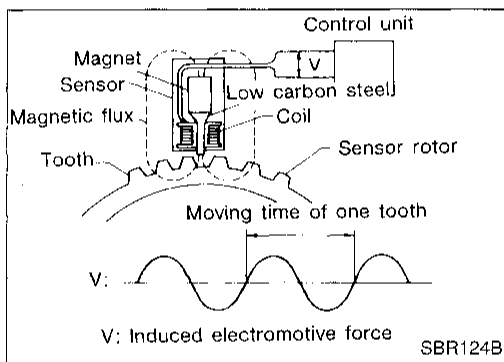
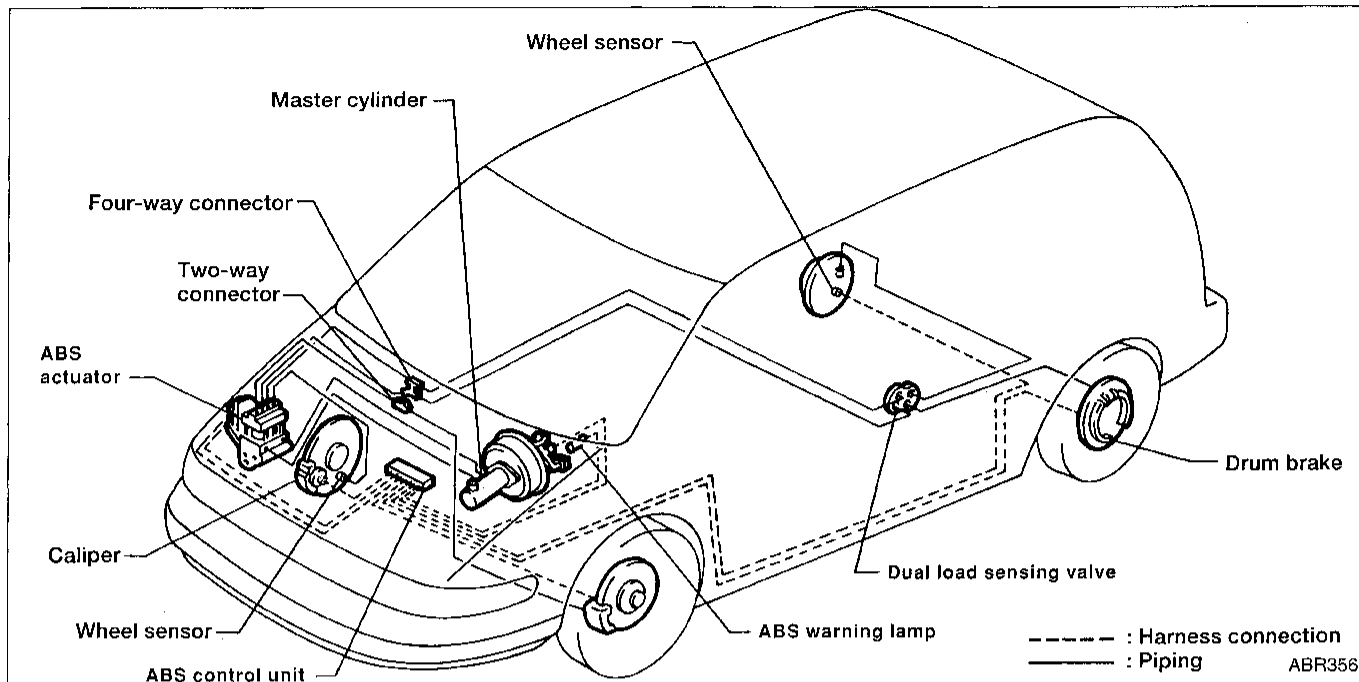

System Description

SENSOR

The sensor unit consists of a gear-shaped sensor rotor and a sensor element. The element contains a bar magnet around which a coil is wound. The sensor is installed on the back side of the brake rotor. Sine-wave current is generated by the sensor as the wheel rotates. The frequency and voltage increase(s) as the rotating speed increases.

CONTROL UNIT

The control unit computes the wheel rotating speed by reading the signal current sent from the sensor. Then it supplies a DC current to the actuator solenoid valve. It also controls ON-OFF operation of the valve relay and motor relay. If any electrical malfunction is detected in the system, the control unit causes the warning lamp to light up. In this condition, the ABS will be deactivated by the control unit, and the vehicle's brake system reverts to normal operation.

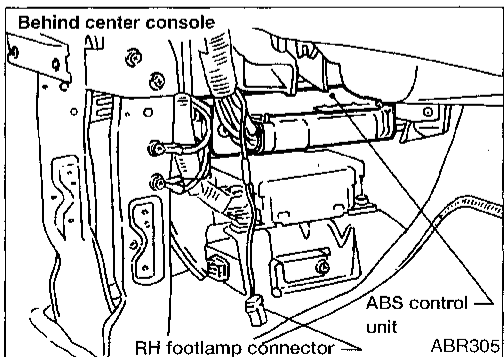
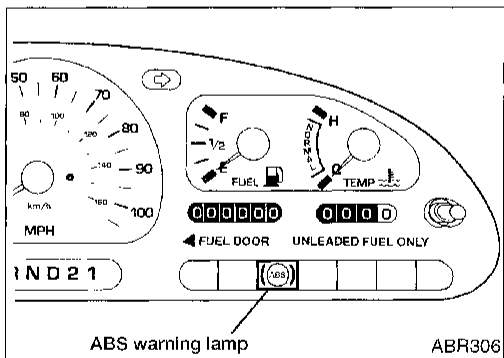

ANTI-LOCK BRAKE SYSTEM

Removal and Installation

CAUTION:

Be careful not to damage sensor edge and sensor rotor teeth.

When removing the front or rear wheel hub assembly, disconnect the ABS wheel sensor from the assembly and move it away.

FRONT WHEEL SENSOR

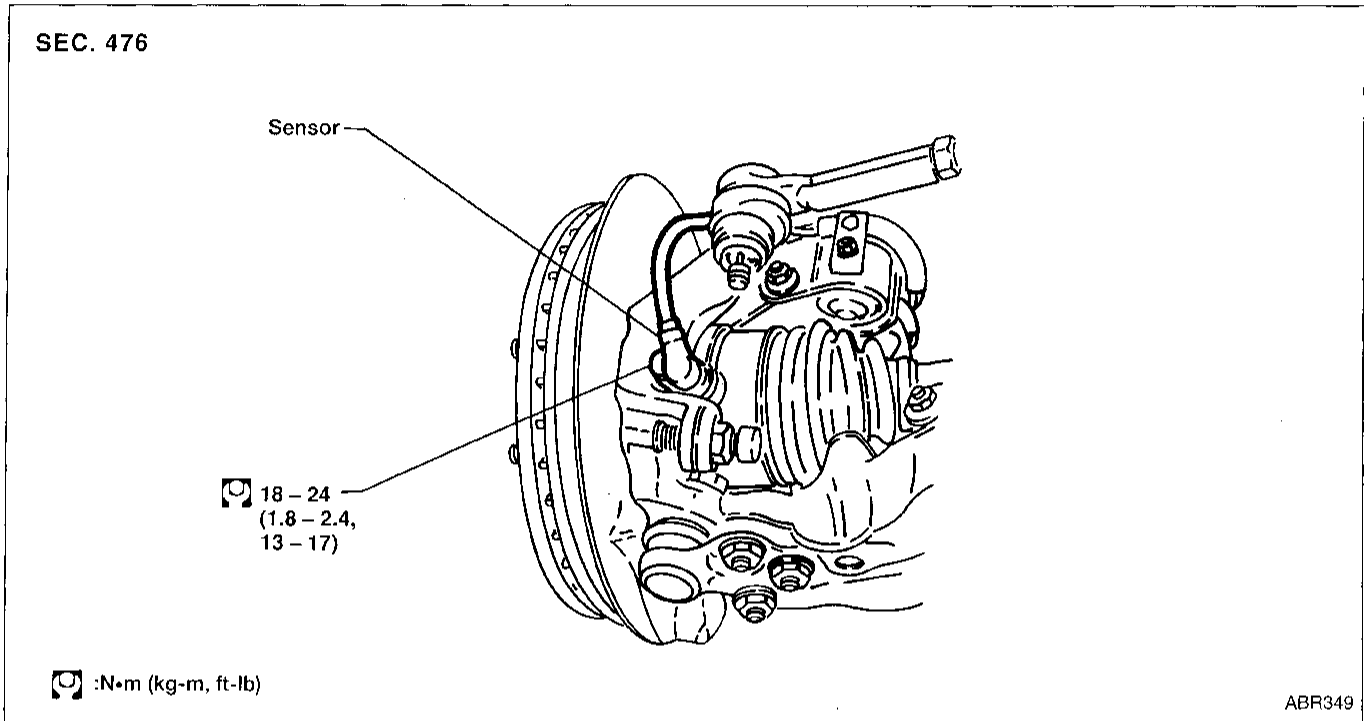

REAR WHEEL SENSOR

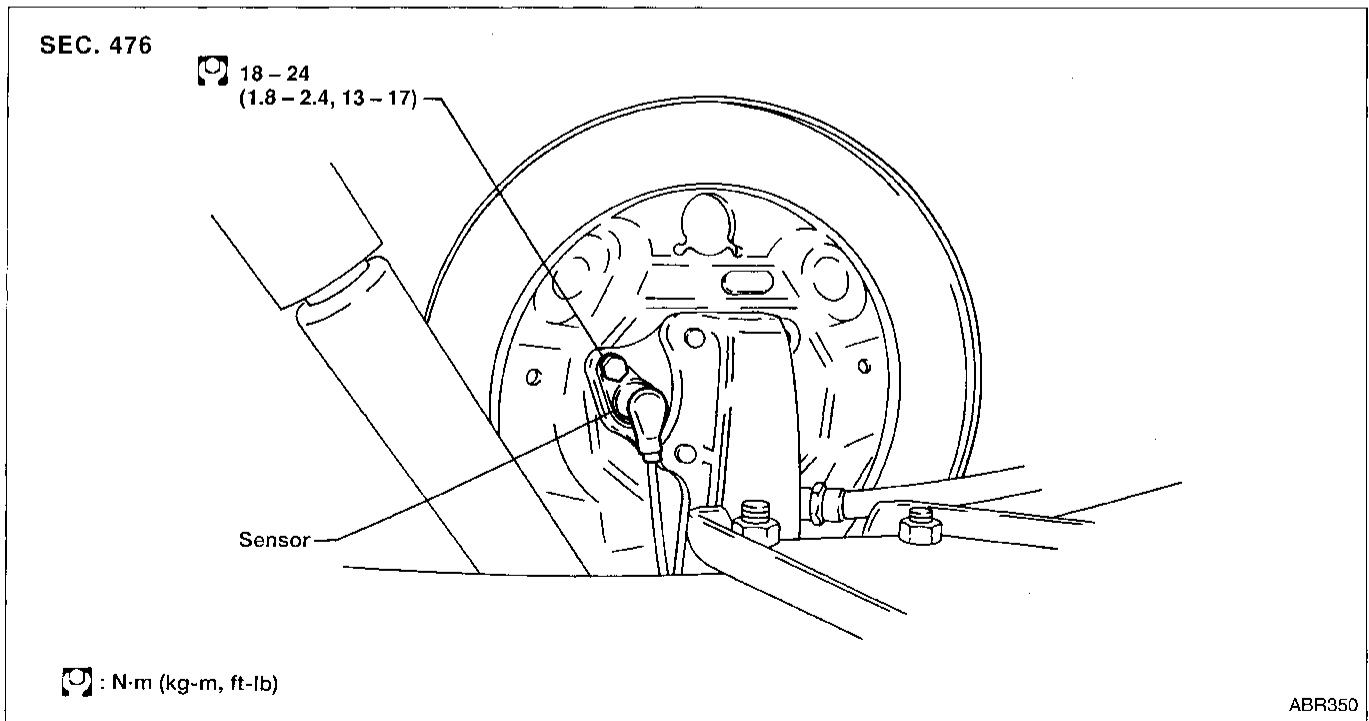

CI
MA
EM
LC
EC
FE
AT
FA
RA
BR
ST
RS
BT
HA
EL
IDX

ANTI-LOCK BRAKE SYSTEM

Removal and Installation (Cont'd) ABS ACTUATOR

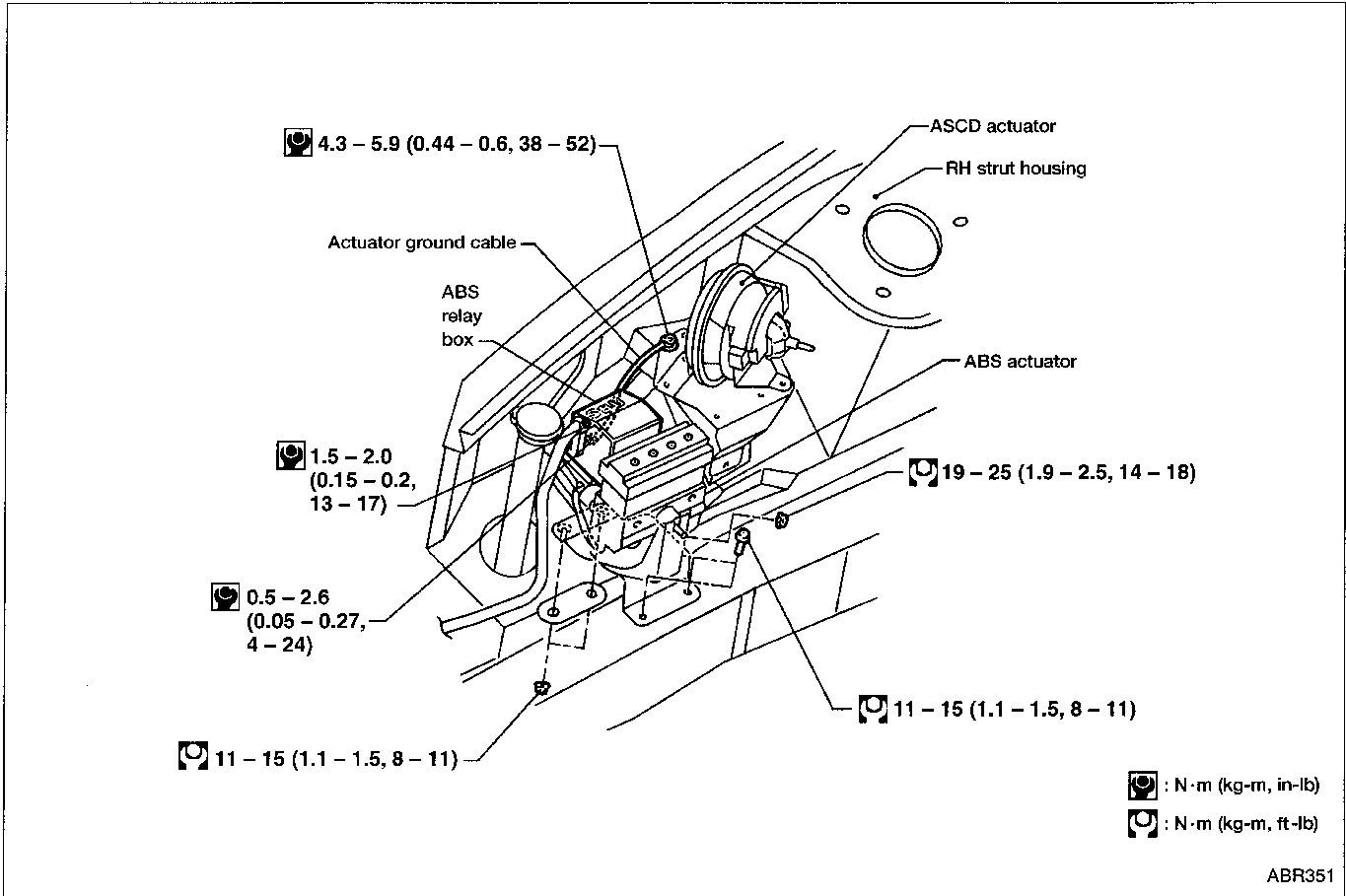

1. Disconnect battery cable.
2. Drain brake fluid. Refer to BR-4.

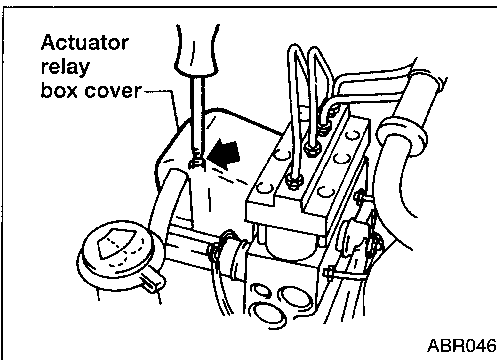

3. Remove screw from relay box cover.
4. Remove cover.

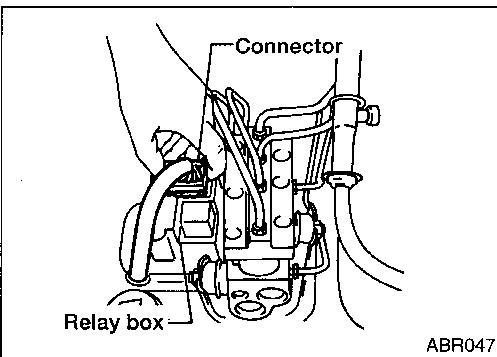

5. Release actuator connector lock tab. Disconnect connector from actuator relay box.

ANTI-LOCK BRAKE SYSTEM

Removal and Installation (Cont'd)

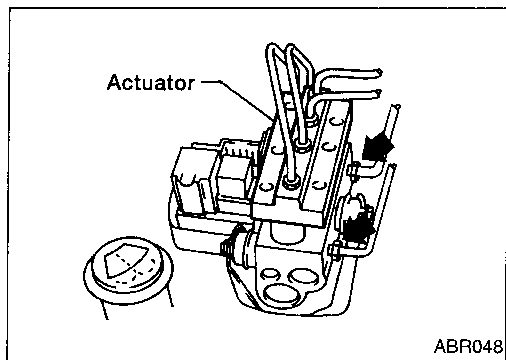

6. Disconnect and separate brake lines and move away from actuator.

It is not necessary to remove these lines from vehicle.

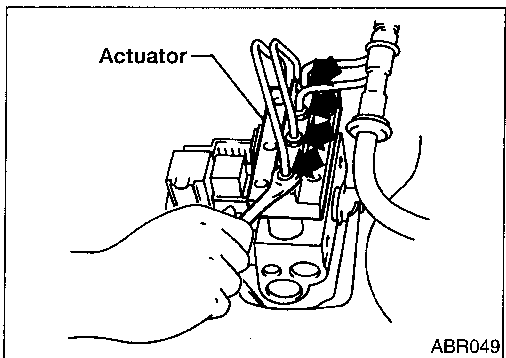

7. Disconnect top four brake lines from actuator. (Lines from actuator to wheels).

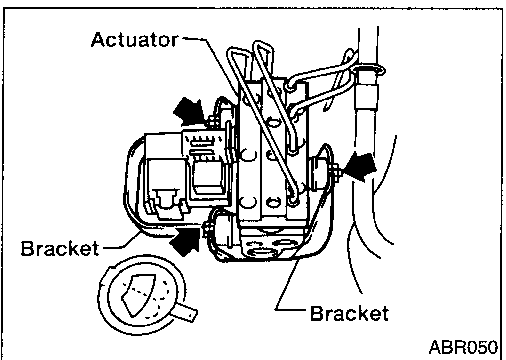

8. Remove/loosen mounting nuts between actuator and bracket.

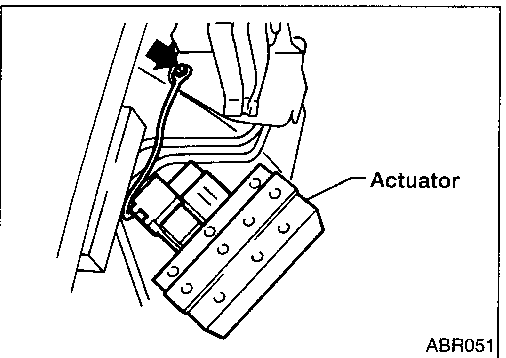

9. Remove the actuator grounding screw.

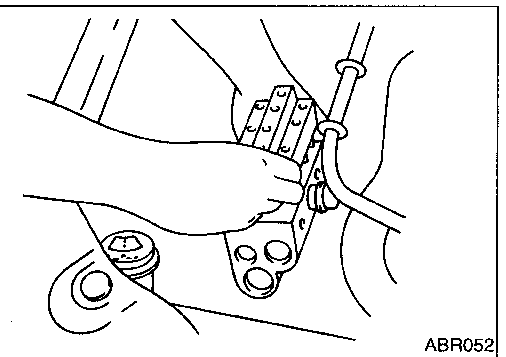

10. Draw out ABS actuator as shown.

GI

MA

EM

LC

EC

FE

AT

FA

RA

BR

ST

RS

BT

HA

EL

IDX

ANTI-LOCK BRAKE SYSTEM

Removal and Installation (Cont'd)

CAUTION:

After installation, pay attention to the following points:

- Refill brake fluid and bleed air. Refer to "CHECK AND ADJUSTMENT", BR-4 and "AIR BLEEDING", BR-5, respectively.
- The installation procedure is the reverse of removal.

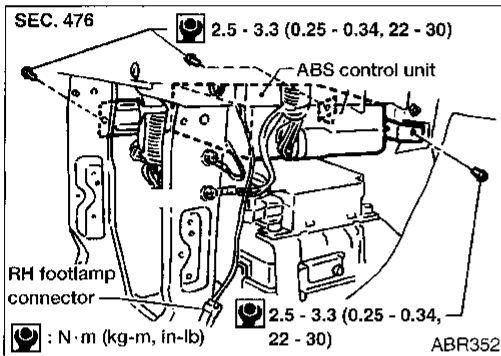

CONTROL UNIT

Location: Behind center console.

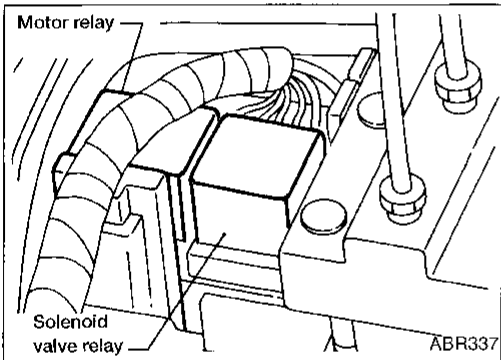

ABS CONTROL ACTUATOR RELAYS

1. Disconnect battery cable.
2. Remove ABS relay cover.

It is not necessary to remove the two screws for relay box.

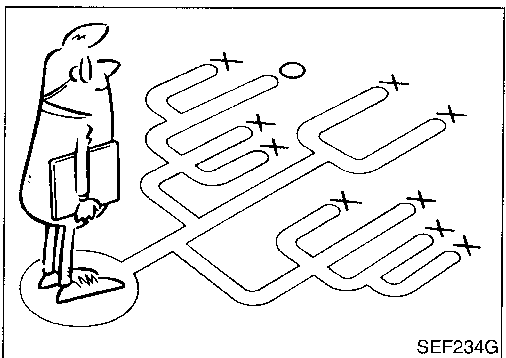
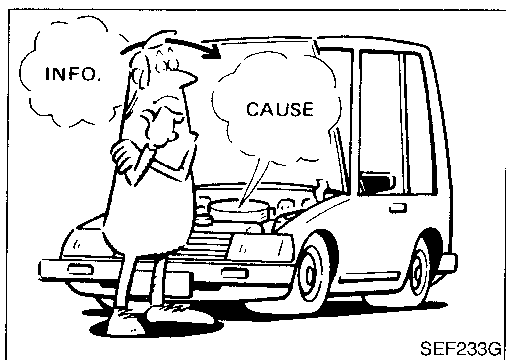

How to Perform Trouble Diagnoses for Quick and Accurate Repair

INTRODUCTION

The ABS system has an electronic control unit to control major functions. The control unit accepts input signals from sensors and instantly drives the actuators. It is essential that both kinds of signals are proper and stable. It is also important to check for conventional problems: air leaks in booster lines, lack of brake fluid or other problems with the brake system.

It is much more difficult to diagnose a problem that occurs intermittently rather than continuously. Most intermittent problems are caused by poor electric connections or faulty wiring. In this case, careful checking of suspicious circuits may help prevent the replacement of good parts.

A visual check only may not find the cause of the problems, so a road test should be performed.

Before undertaking actual checks, take a few minutes to talk with a customer who approaches with a ABS complaint. The customer is a very good source of information on such problems; especially intermittent ones. Through the talks with the customer, find out what symptoms are present and under what conditions they occur.

Start your diagnosis by looking for "conventional" problems first. This is one of the best ways to troubleshoot brake problems on an ABS controlled vehicle.

GI

MA

EM

LC

BC

FE

AT

FA

RA

BR

ST

RS

BT

HA

EL

IDX

TROUBLE DIAGNOSES

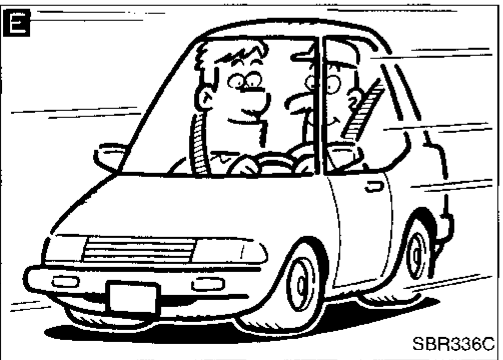
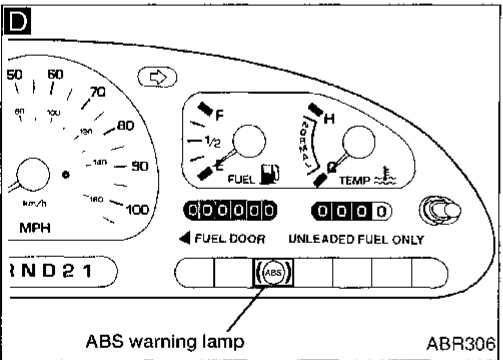
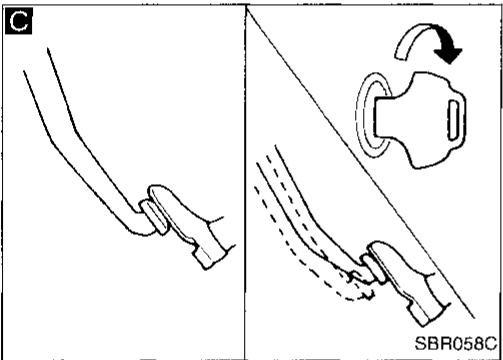
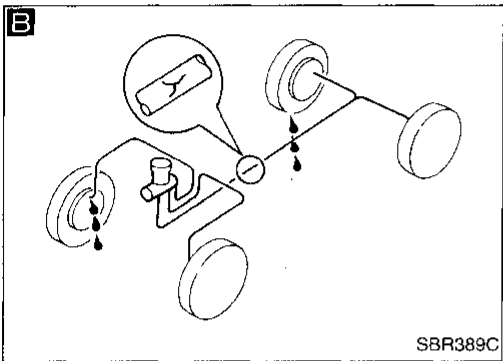
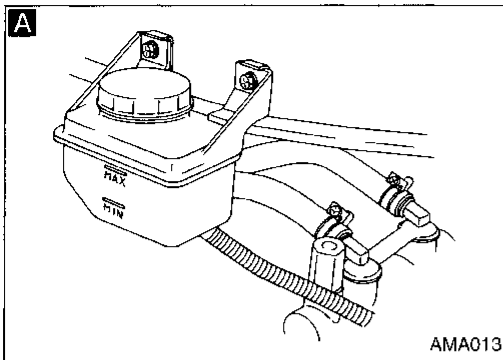

Preliminary Check

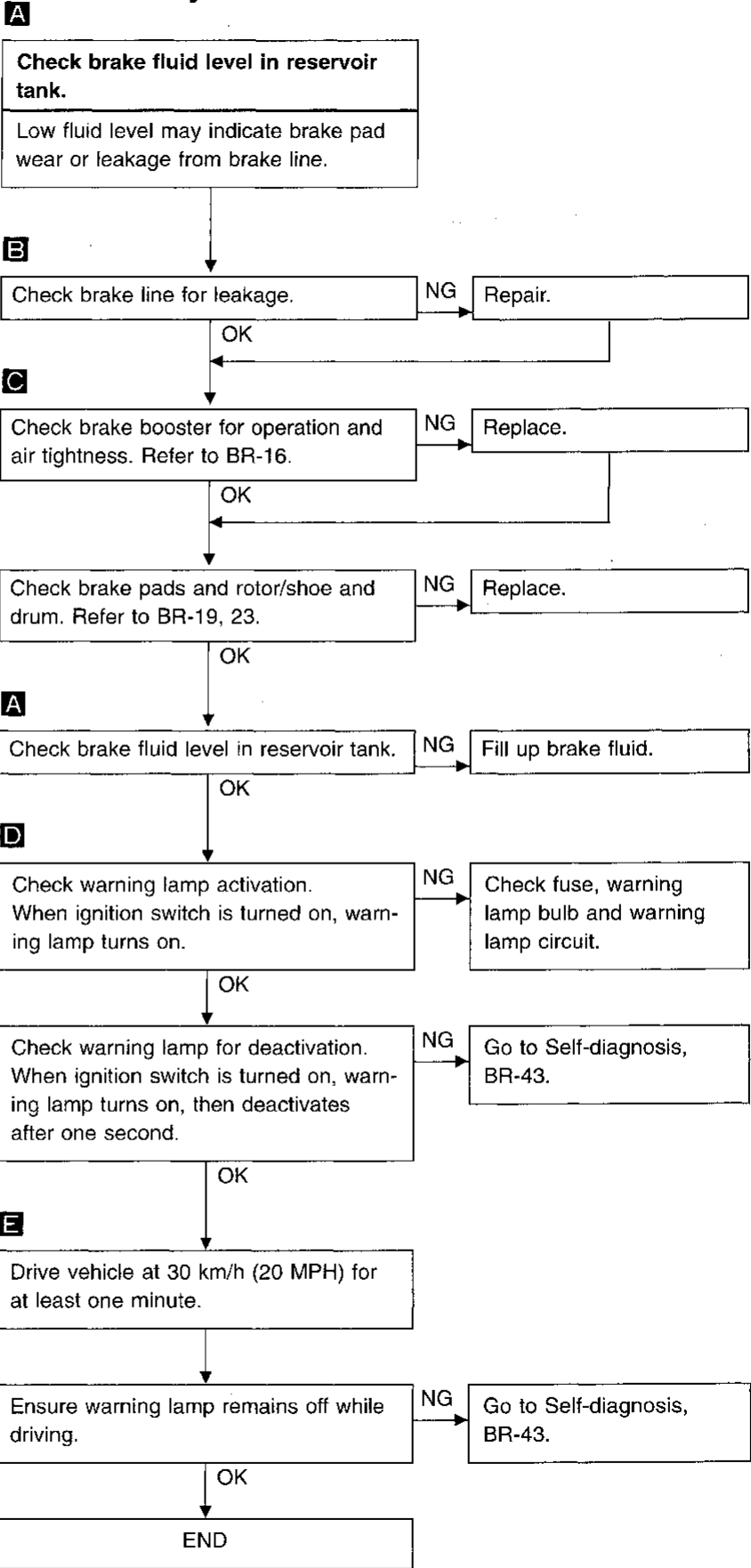

TROUBLE DIAGNOSES

Component Parts Location and Harness Layout

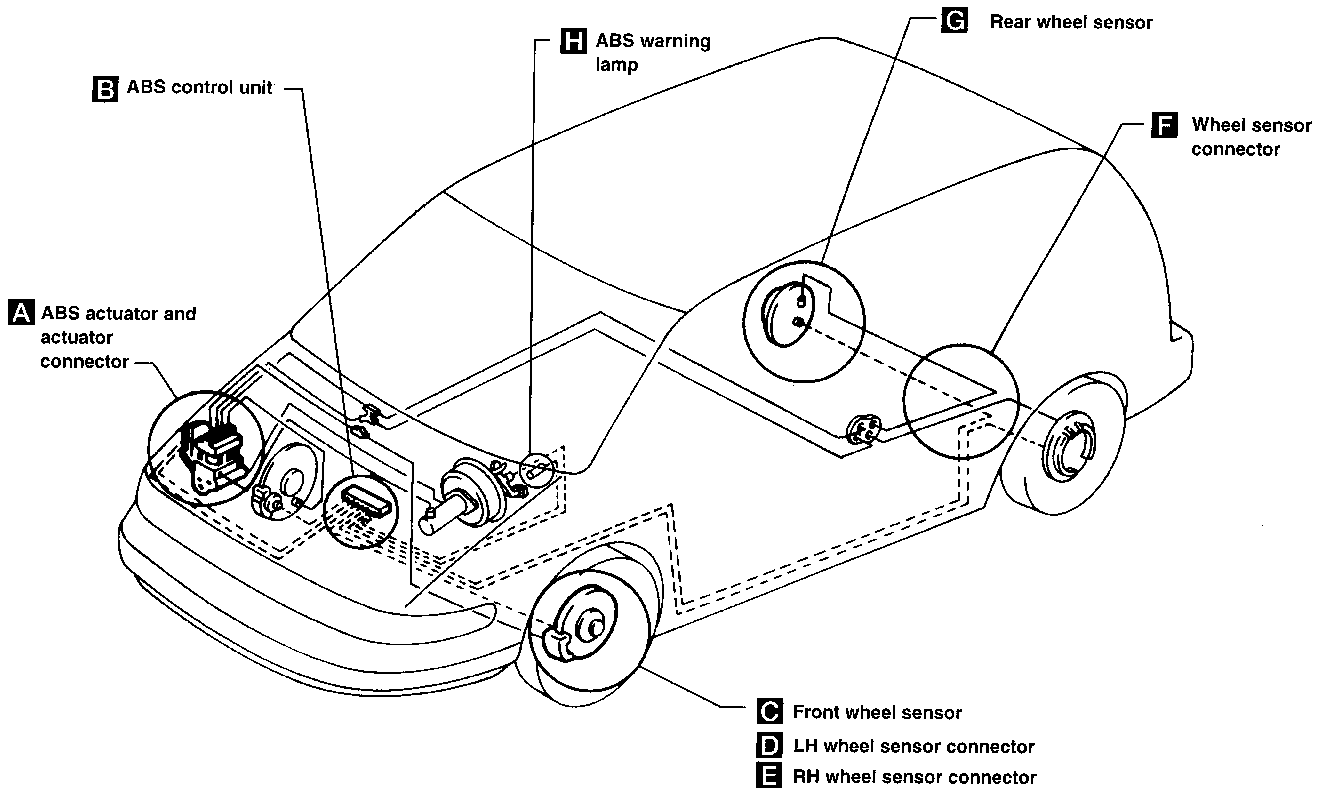

GI
MA
EM
LC
EC
FE
AT
FA
RA

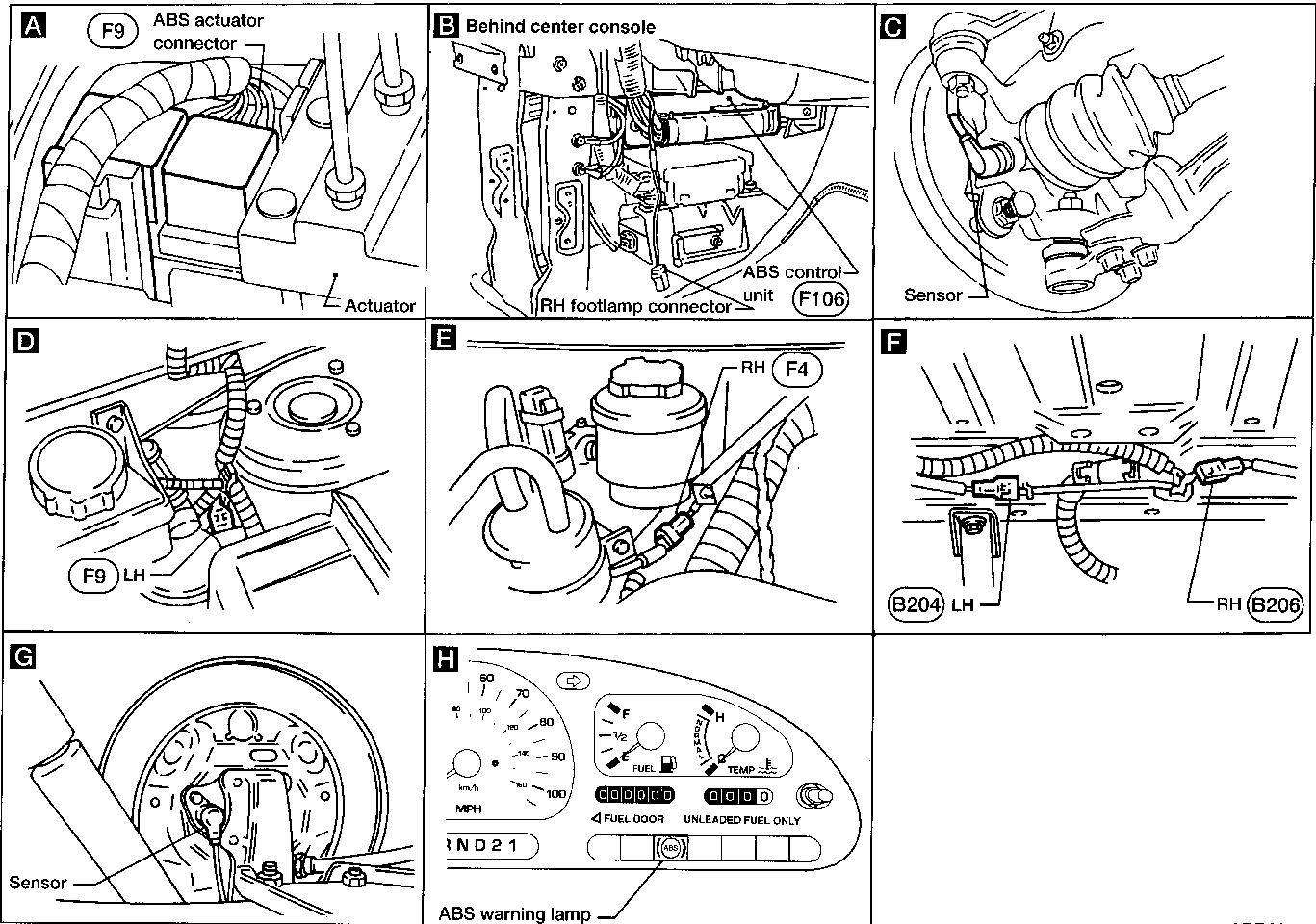

BR
ST
RS
BT
HA
EL
IDX

ABR307

Circuit Diagram

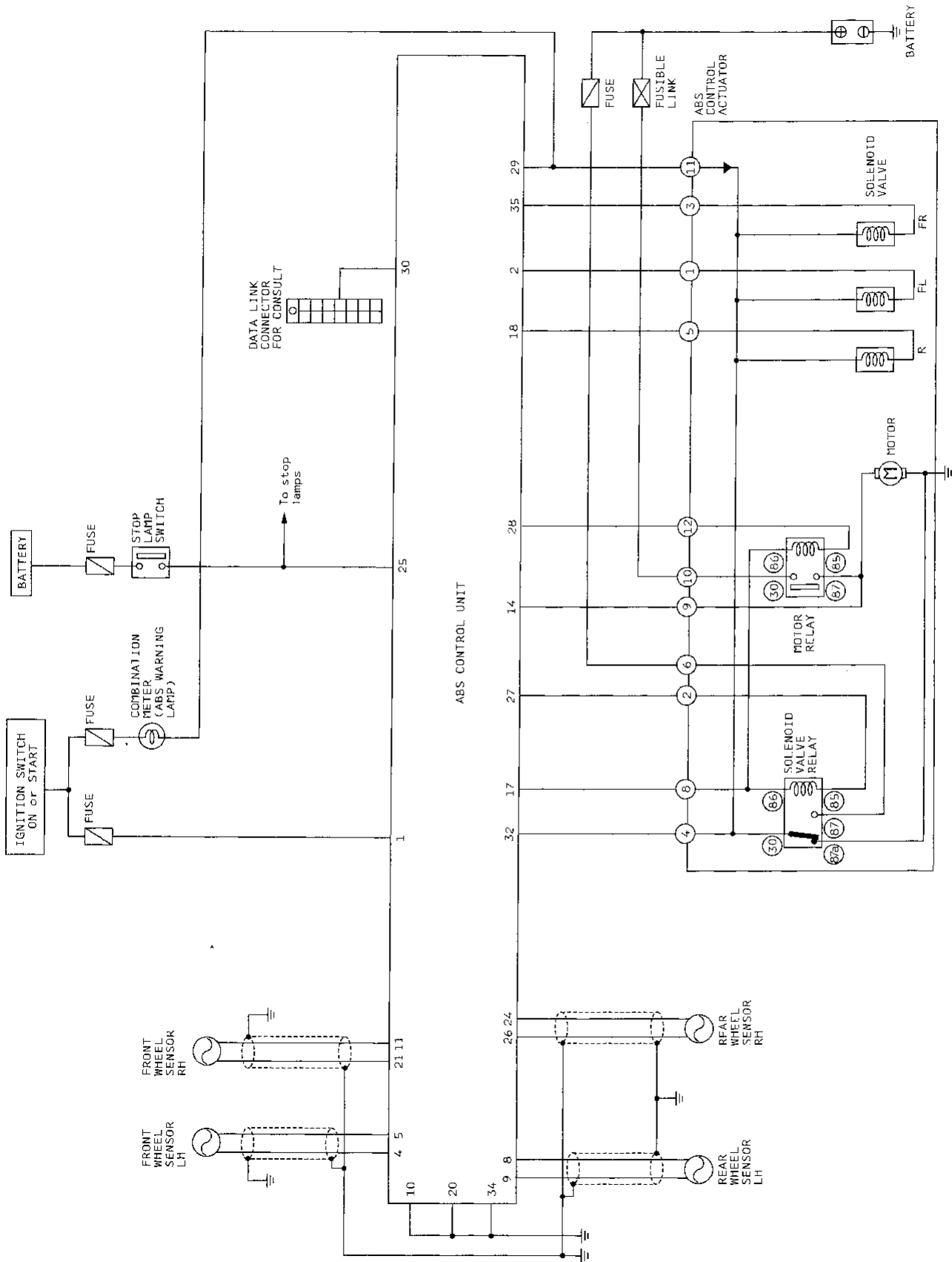

TROUBLE DIAGNOSES

Wiring Diagram -ABS- (Cont'd)

BR-ABS-02

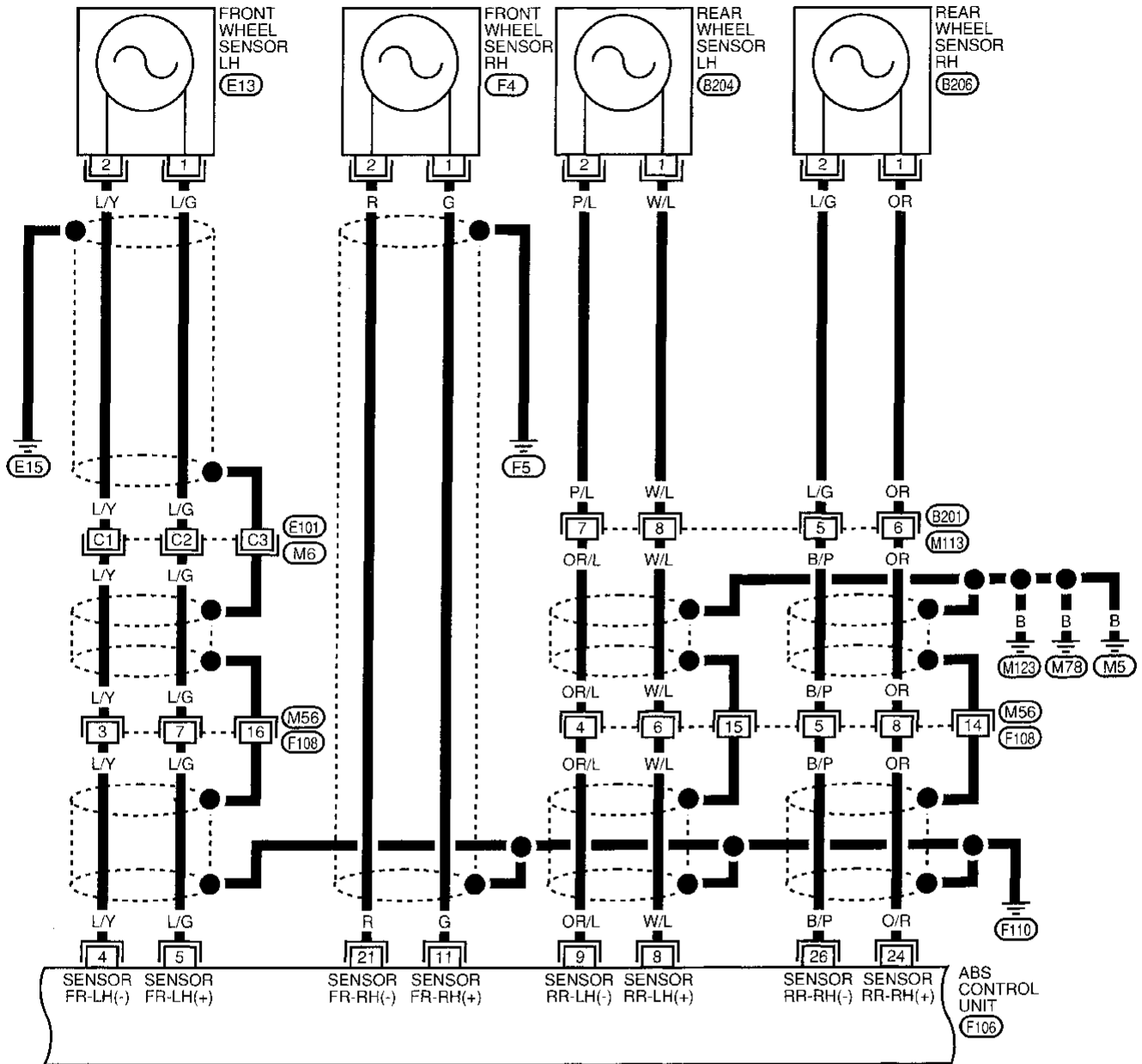

Refer to last page (Foldout page).

M6, E101

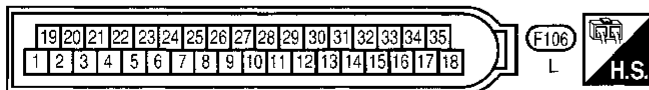
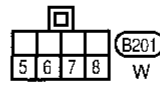
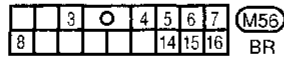
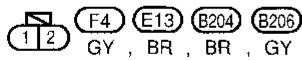

TROUBLE DIAGNOSES

Wiring Diagram -ABS- (Cont'd)

BR-ABS-03

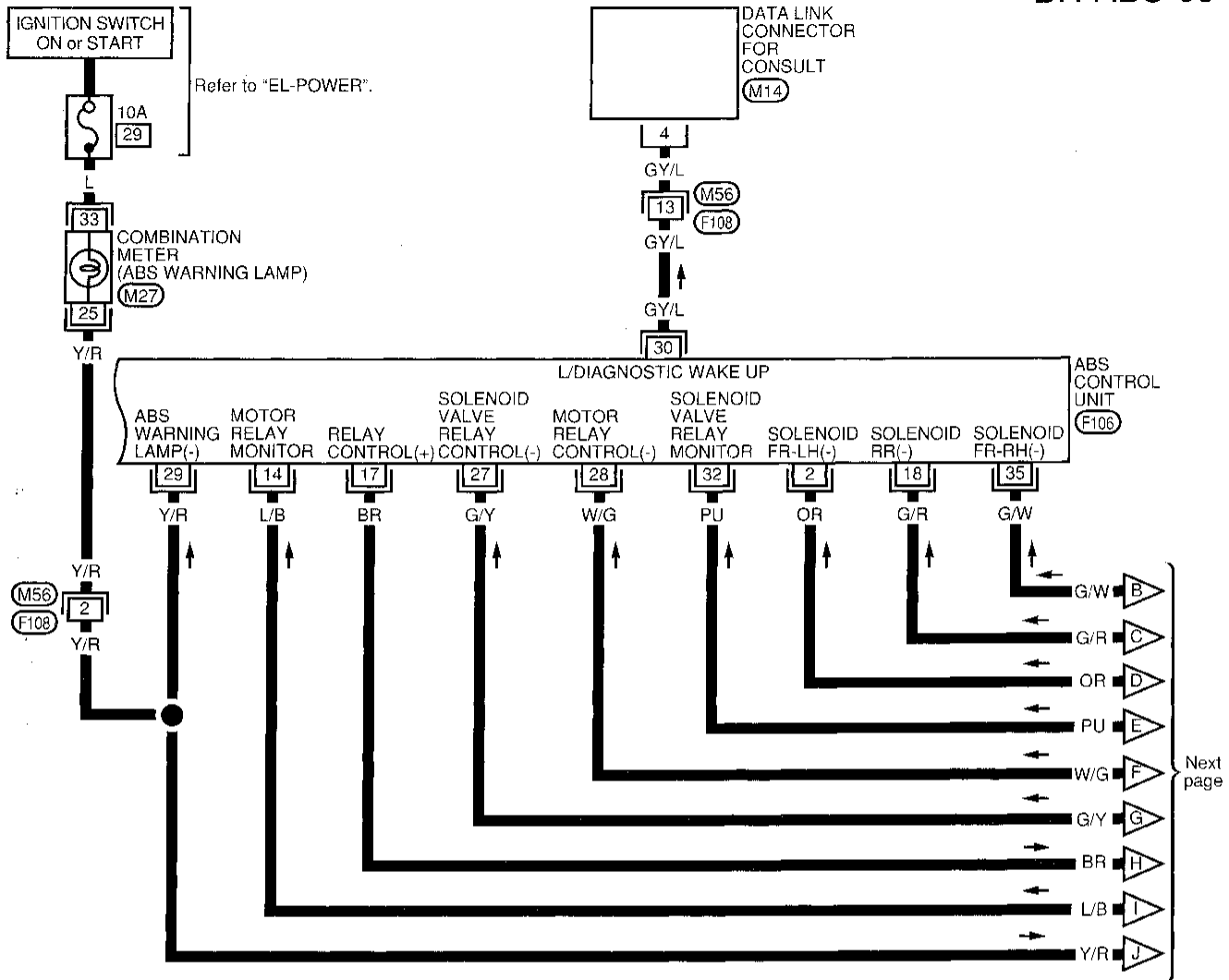

GI
MA
EM
LC
EC
FE
AT
FA
BA
BR
ST
ES
BT
HA
EL
DX

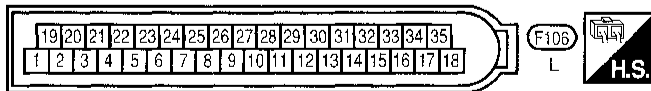
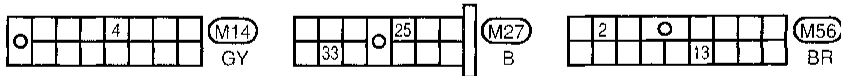

TROUBLE DIAGNOSES

Wiring Diagram -ABS- (Cont'd)

BR-ABS-04

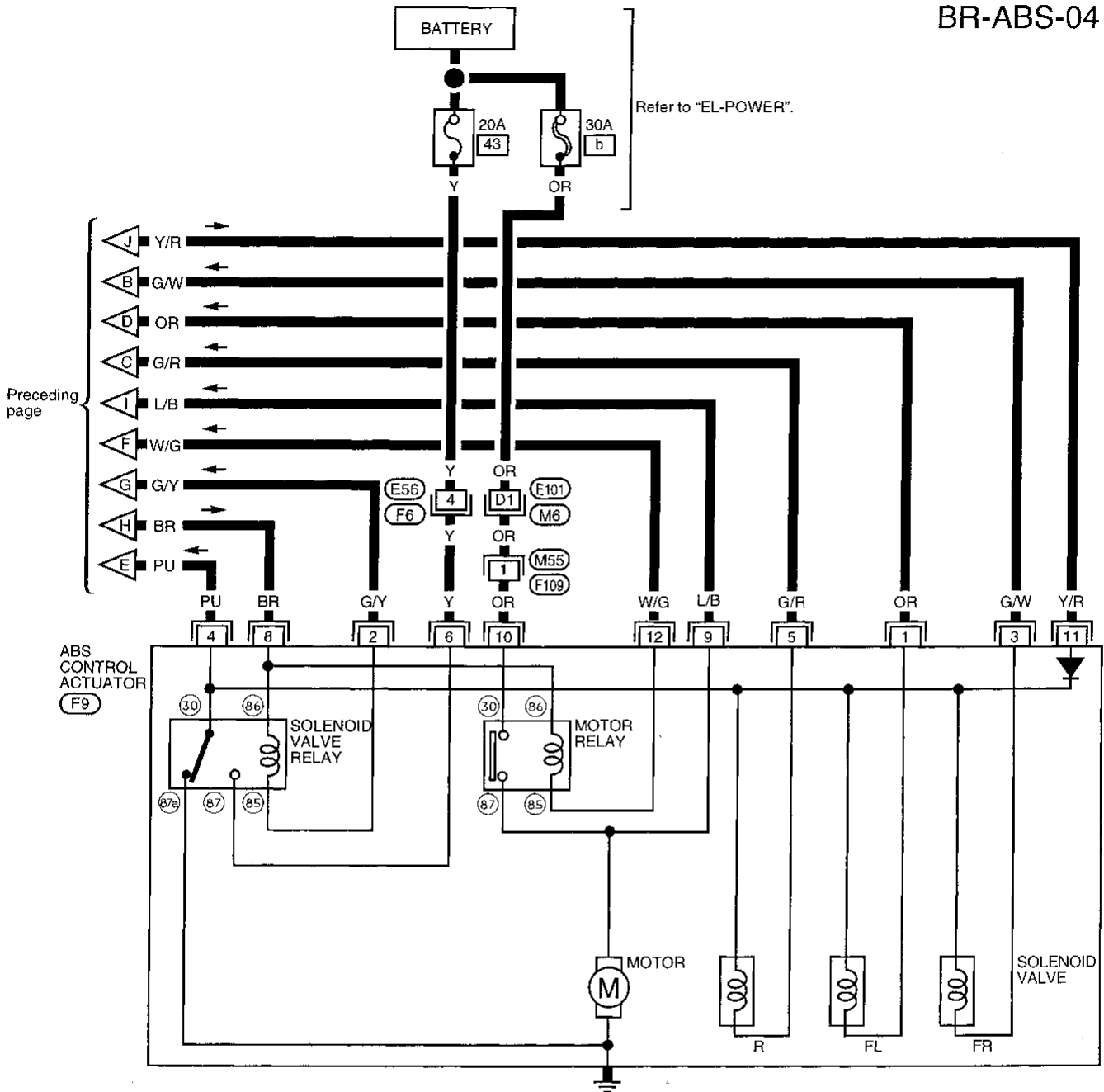

Refer to last page (Foldout page).

(M6), (E101)

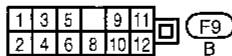

Self-diagnosis

FUNCTION

- When a problem occurs in the ABS, the warning lamp on the instrument panel comes on. To start the self-diagnostic results mode, ground the self-diagnostic (check) terminal located on "Data Link Connector for CONSULT". The location of the malfunction is indicated by the warning lamp flashing.

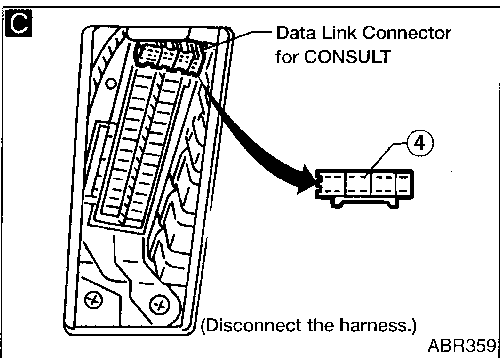
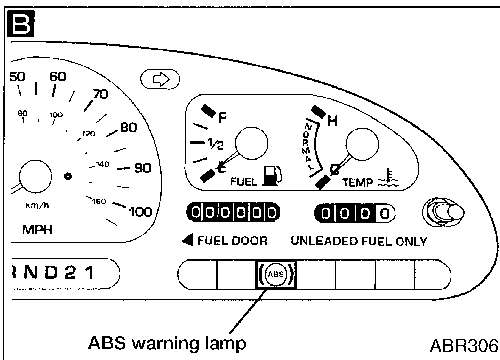
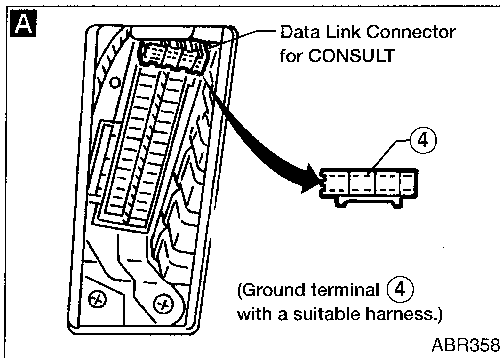

SELF-DIAGNOSIS PROCEDURE

Drive vehicle over 30 km/h (20 MPH) for at least one minute.

Turn ignition switch "OFF".

A Ground terminal "④" of Data Link Connector for CONSULT with a suitable harness.

Turn ignition switch "ON" while grounding terminal "④".
Do not depress brake pedal.

B After 3.6 seconds, the warning lamp starts flashing to indicate the malfunction code No.

Verify the location of the malfunction with the malfunction code chart. Refer to BR-45. Then make the necessary repairs following the diagnostic procedures.

After the malfunctions are repaired, erase the malfunction codes stored in the control unit. Refer to BR-44.

Rerun the self-diagnostic results mode to verify that the malfunction codes have been erased.

C Disconnect the check terminal from the ground. The self-diagnostic results mode is now complete.

A

TROUBLE DIAGNOSES

Self-diagnosis (Cont'd)

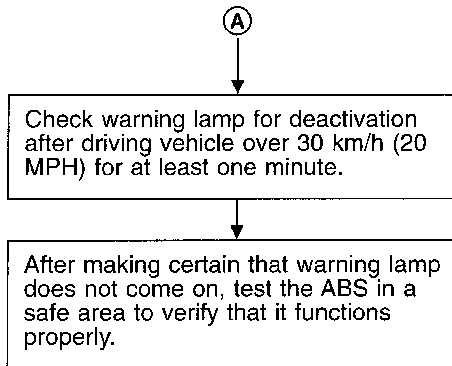

HOW TO READ SELF-DIAGNOSTIC RESULTS (Malfunction codes)

- Determine the code No. by counting the number of times the warning lamp flashes on and off.
- When several malfunctions occur at one time, up to three code numbers can be stored; the latest malfunction will be indicated first.
- The indication begins with the start code 12. After that a maximum of three code numbers appear in the order of the latest one first. The indication then returns to the start code 12 to repeat (the indication will stay on for a maximum of five minutes).
- The malfunction code chart is given on the next page.

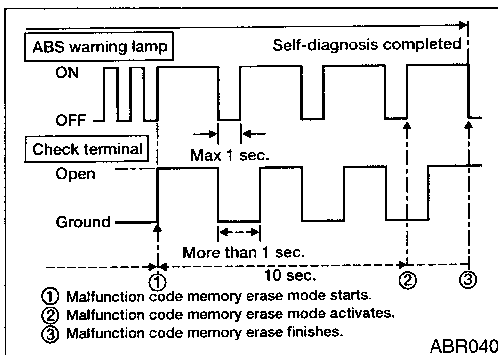
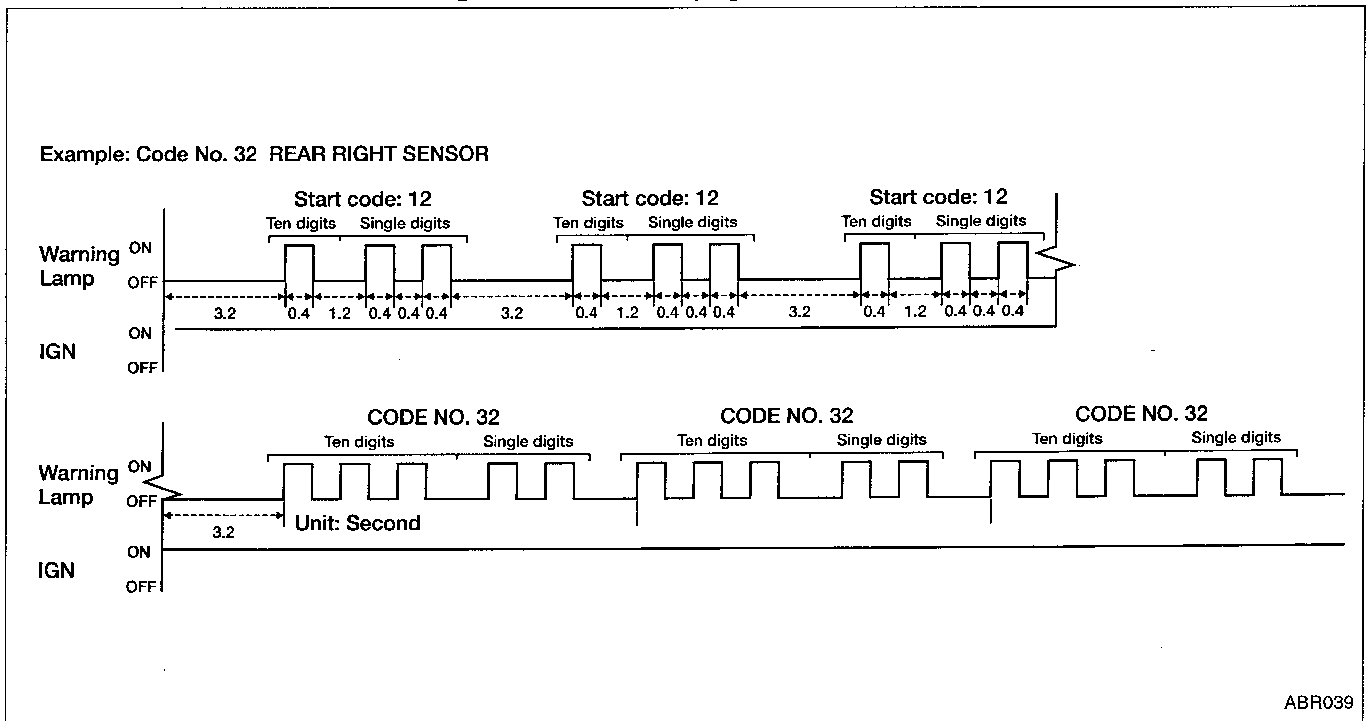

HOW TO ERASE SELF-DIAGNOSTIC RESULTS (Malfunction codes)

1. Disconnect the check terminal from ground (ABS warning lamp will blink).
2. Within 10 seconds, ground the check terminal 3 times. Each terminal grounding must last more than 1 second. The ABS warning lamp goes out after the erase operation has been completed.
3. Perform self-diagnosis again. Refer to BR-43. Only the start code should appear, no malfunction codes.

TROUBLE DIAGNOSES

Self-diagnosis (Cont'd)

MALFUNCTION CODE/SYMPTOM CHART

Code No. (No. of LED flashes)	Malfunctioning part	Diagnostic procedure	
45*	Front left actuator solenoid	3	GI
41*	Front right actuator solenoid	3	
55*	Rear actuator solenoid	3	MA
25	Front left sensor (open-circuit)	4	
26	Front left sensor (frequency error)	4	EM
21	Front right sensor (open-circuit)	4	
22	Front right sensor (frequency error)	4	LC
35	Rear left sensor (open-circuit)	4	
36	Rear left sensor (frequency error)	4	EC
31	Rear right sensor (open-circuit)	4	
32	Rear right sensor (frequency error)	4	FE
18	Sensor rotor (frequency error)	4	
61	Actuator motor or motor relay	5	
63*	Solenoid valve relay	6	AT
71	Control unit	7	
Warning lamp stays on when ignition switch is turned on	Control unit power supply circuit Warning lamp bulb circuit Control unit or control unit connector Solenoid valve relay stuck Power supply for solenoid valve relay coil	2	FA RA
Warning lamp stays on during self-diagnosis	Control unit	—	BR
Warning lamp does not come on when ignition switch is turned on	Fuse, warning lamp bulb or warning lamp circuit Control unit	1	ST
Warning lamp does not come on during self-diagnosis	Control unit	—	RS
Pedal vibration and noise	—	8	
Long stopping distance	—	9	
Unexpected pedal action	—	10	BT
ABS does not work	—	11	
ABS works frequently	—	12	HA

*: When these malfunctions occur, warning lamp stays on; does not blink. Remove the solenoid valve relay to obtain the malfunction code.

GI

MA

EM

LC

EC

FE

AT

FA

RA

BR

ST

RS

BT

HA

EL

IDX

TROUBLE DIAGNOSES

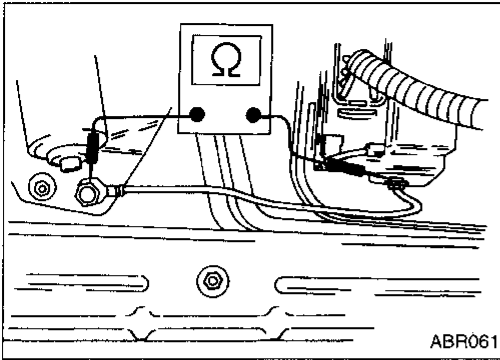

Ground Circuit Check

ACTUATOR MOTOR GROUND

- Check resistance between actuator motor ground terminal and body ground.
Resistance: 0Ω

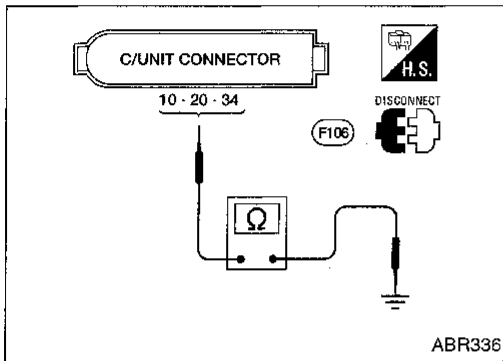

CONTROL UNIT GROUND

- Check resistance between the terminals and ground.
Resistance: 0Ω

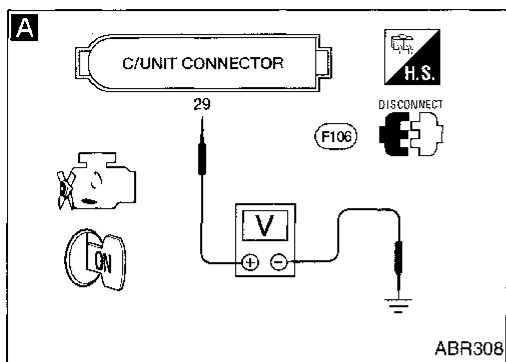

Diagnostic Procedure 1 (Not self-diagnostic item)

Warning lamp does not come on when ignition switch is turned on.

WARNING LAMP CIRCUIT CHECK

Check 10A fuse 29 for warning lamp. For fuse layout, refer to BR-41.

NG → Replace fuse.

OK

Check warning lamp bulb.

NG → Replace bulb.

OK

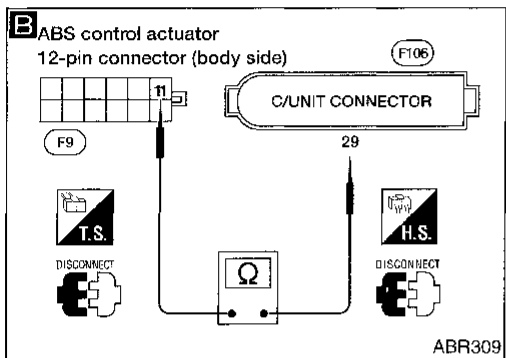

- A**
1. Install 10A fuse and bulb.
 2. Disconnect connectors from control unit and ABS control actuator.
 3. Check voltage between control unit connector terminal 29 and ground after turning ignition switch "ON". **Battery voltage should exist after turning ignition switch "ON".**

NG → Repair harness and connectors.

OK

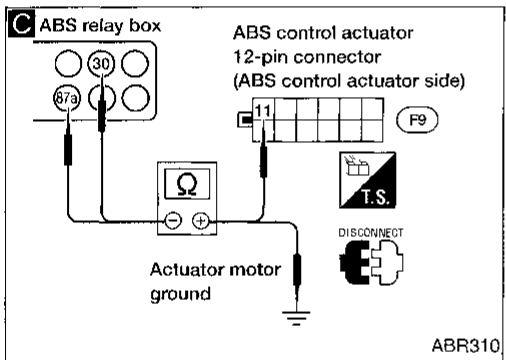

- B**
1. Check continuity between ABS control actuator 12-pin connector (body side) and control unit terminal.
- | ABS control actuator | Control unit |
|----------------------|--------------|
| 11 | 29 |
2. Check continuity between ABS actuator motor ground and control unit ground. **Continuity should exist.**

NG → Repair harness and connectors.

OK

- C**
1. Remove solenoid valve relay.
 2. Check continuity between ABS control actuator 12-pin connector (ABS control actuator side) and ABS relay box terminals.
- | ABS control actuator connector | ABS relay box terminals |
|--------------------------------|-------------------------|
| 11 ⊕ | 30 ⊖ |
3. Check continuity between ABS actuator motor ground and ABS relay box terminal 87a. **Continuity should exist.**
Note: Pay attention to tester polarity*.

NG → Replace ABS control actuator.

OK

SOLENOID VALVE RELAY CHECK

Refer to SOLENOID VALVE RELAY in Electrical Components Inspection, BR-63.

NG → Replace solenoid valve relay.

OK

Check control unit pin terminals for damage or the connection of control unit harness connector. Reconnect control unit harness connector. Then retest.

*: Specifications may vary depending on the type of tester. Before performing this inspection, refer to the instruction manual of the tester.

TROUBLE DIAGNOSES

Diagnostic Procedure 2 (Not Self-diagnostic item)

Warning lamp stays on when ignition switch is turned on.

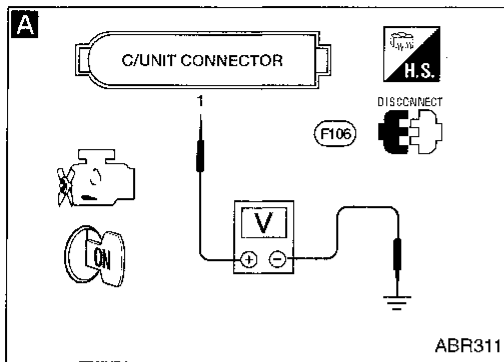

CONTROL UNIT POWER SUPPLY CIRCUIT

Check 10A fuse 30 for control unit. For fuse layout, refer to BR-39.

NG (Go to B on BR-50.)

A

1. Disconnect connector from control unit.
2. Check voltage between control unit connector terminal ① and ground after turning ignition switch "ON". **Battery voltage should exist.**

NG Repair harness and connector.

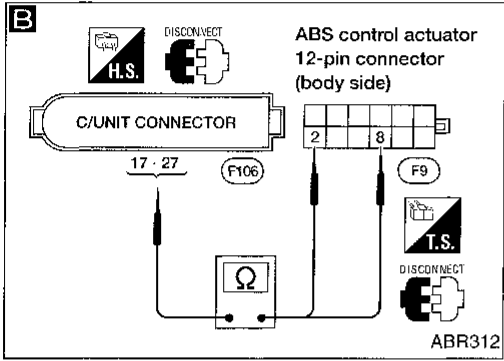

B

SOLENOID VALVE RELAY COIL POWER SUPPLY CIRCUIT

1. Turn ignition switch "OFF". Disconnect ABS control actuator 12-pin connector.
2. Check continuity between control unit connector terminals and ABS control actuator 12-pin connector (body side) terminals.

NG Repair harness and connector.

Control unit	ABS control actuator
①⑦	⑧
②⑦	②

Continuity should exist.

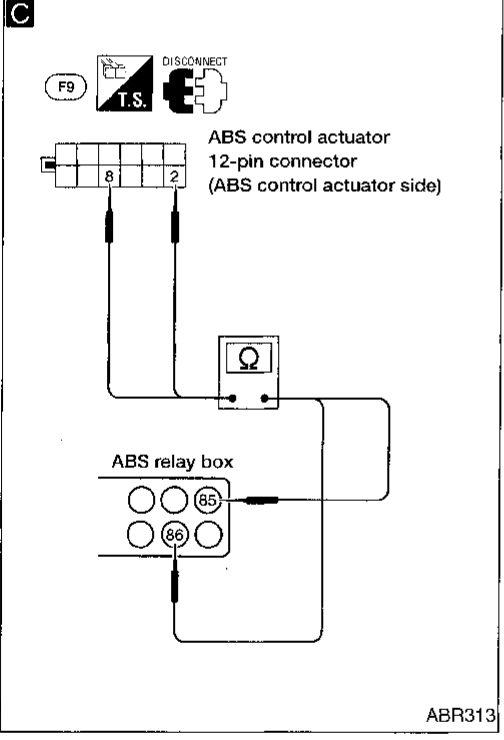

C

CIRCUIT CHECK

1. Disconnect solenoid valve relay.
2. Check continuity between ABS control actuator 12-pin connector (ABS control actuator side) terminals and solenoid valve relay box terminals.

NG Replace ABS control actuator.

ABS control actuator connector	ABS relay box terminals
⑧	⑧⑥
②	⑧⑤

Continuity should exist.

SOLENOID VALVE RELAY CHECK

Refer to SOLENOID VALVE RELAY in Electrical Components Inspection, BR-63.

NG Replace solenoid valve relay.

OK
A
(Go to next page.)

TROUBLE DIAGNOSES

Diagnostic Procedure 2 (Not Self-diagnostic item) (Cont'd)

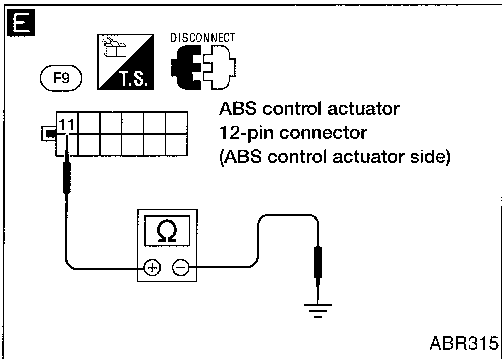
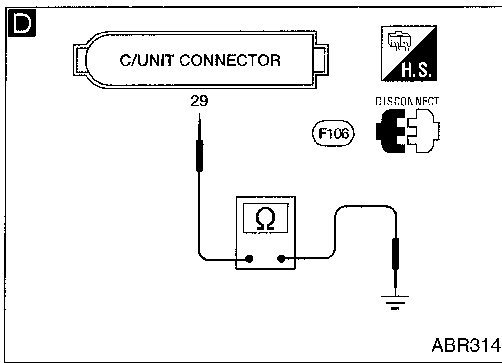

D

GROUND-SHORT CHECK FOR WARNING LAMP CIRCUIT.

1. Turn ignition switch "OFF".
2. Disconnect connectors from control unit and ABS control actuator 12-pin connector.
3. Check continuity between control unit connector terminal ②9 and body ground.

Continuity should not exist.

NG → Repair harness and connector.

OK

E

1. Disconnect actuator ground terminal and ABS control actuator 12-pin connector.
2. Check continuity between ABS control actuator 12-pin connector (ABS control actuator side) terminal ①1 and body ground.

Continuity should not exist.

Note: Pay attention to tester polarity*.

NG → Replace ABS control actuator.

OK

Check control unit pin terminals for damage or the connection of control unit harness connector. Reconnect control unit harness connector. Then retest.

*: Specifications may vary depending on the type of tester. Before performing this inspection, refer to the instruction manual of the tester.

GI
WA
EM
LC
EC
FE
AT
FA
RA
BR
ST
RS
BT
HA
FL
ICX

TROUBLE DIAGNOSES

Diagnostic Procedure 2 (Not Self-diagnostic item) (Cont'd)

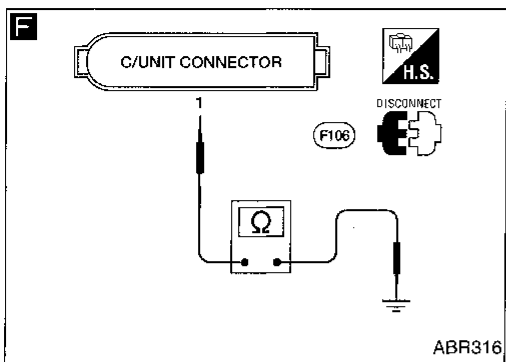

(B)

Replace 10A fuse 30 .
Does the fuse blow out when ignition switch is turned "ON"?

No → Inspection end

Yes →

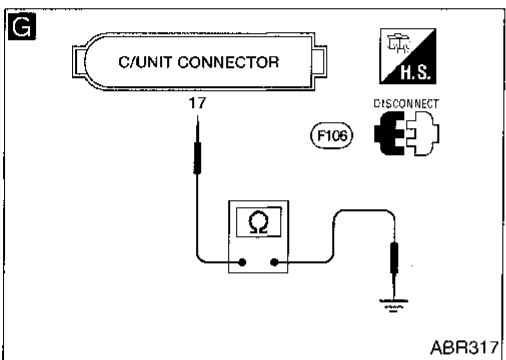

CONTROL UNIT POWER SUPPLY CIRCUIT

1. Disconnect control unit connector.
2. Check continuity between control unit connector terminal ① and body ground.
Continuity should not exist.

NG → Repair harness and connector.

OK →

(G)

Check continuity between control unit connector terminal ⑰ and body ground.
Continuity should not exist.

NG → Repair harness and connector.

OK →

Check control unit pin terminals for damage or the connection of control unit harness connector.
Reconnect control unit harness connector. Then retest.

TROUBLE DIAGNOSES

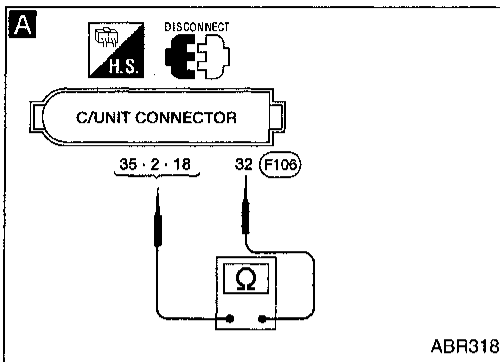

Diagnostic Procedure 3

ABS CONTROL ACTUATOR SOLENOID VALVE (Malfunction code No. 41, 45, 55)

1. Disconnect connectors from control unit and ABS control actuator. Check terminals for damage or loose connections. Then reconnect connectors.
2. Carry out self-diagnosis again.
Does warning lamp activate again?

No → Inspection end

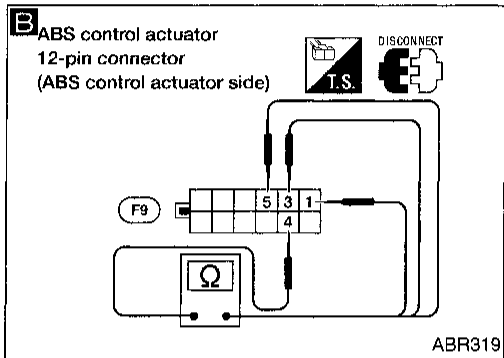

A

ABS ACTUATOR SOLENOID VALVE CHECK

1. Disconnect connector from control unit.
2. Check resistance between control unit connector terminals.

Code No.	Control unit	Control unit	Resistance
41	③⑤	③②	1.07 - 1.17Ω
45	②	③②	
55	①③	③②	

OK → (A) (Go to next page.)

NG

- B**
1. Disconnect ABS control actuator 12-pin connector.
 2. Check resistance between ABS control actuator 12-pin connector (ABS control actuator side) terminals.

Code No.	ABS control actuator	ABS control actuator	Resistance
41	③	④	1.07 - 1.17Ω
45	①	④	
55	⑤	④	

OK → Repair harness and connector between control unit connector terminal and ABS control actuator 12-pin connector terminal.

NG

Replace ABS control actuator.

GI
MA
EM
LC
EC
FE
AT
FA
RA
BR
ST
RS
BT
HA
EL
IDX

TROUBLE DIAGNOSES

Diagnostic Procedure 3 (Cont'd)

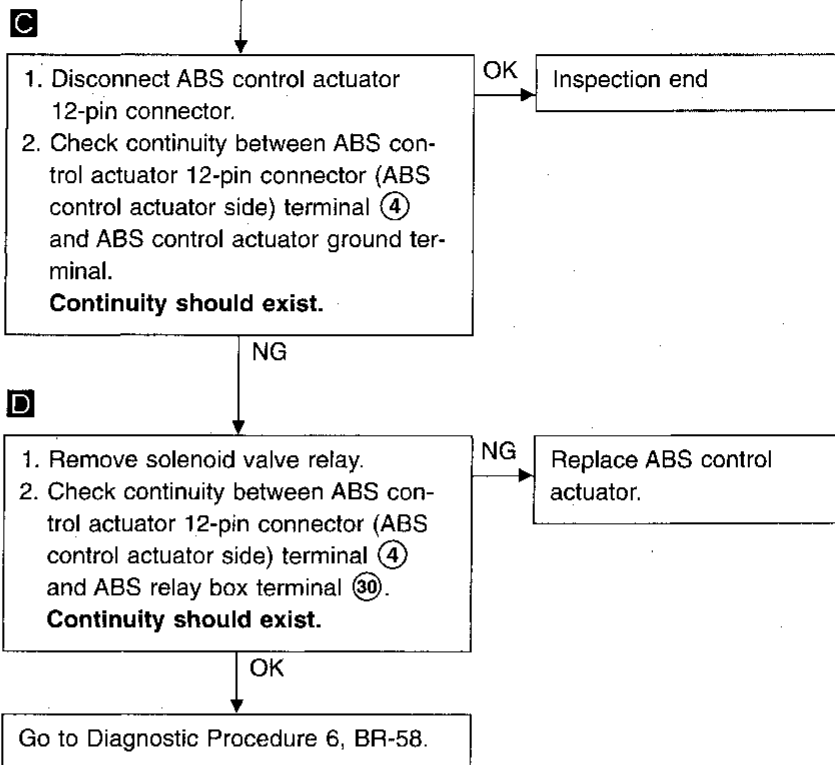
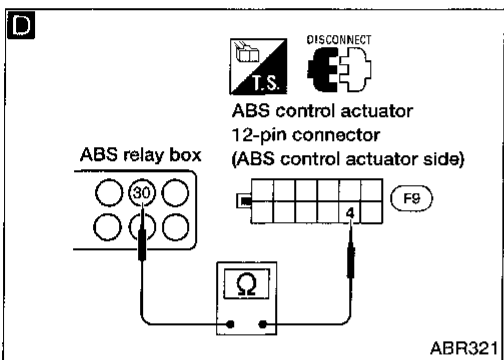
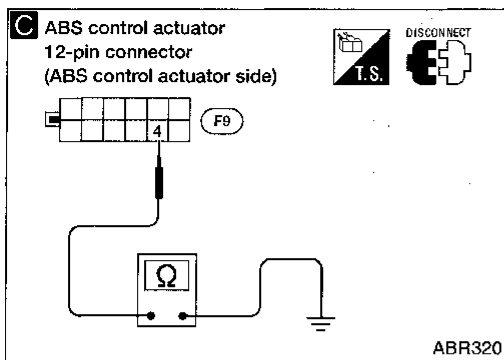

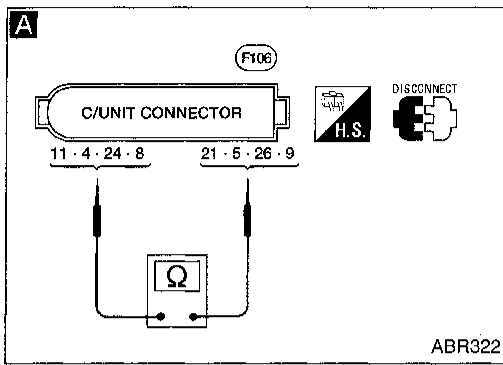

Diagnostic Procedure 4

WHEEL SENSOR OR ROTOR

(Malfunction code No. 21, 22, 25, 26, 31, 32, 35, 36 or 18)

1. Disconnect connectors from control unit and wheel sensor of malfunction code No. Check terminals for damage or loose connections. Then reconnect connectors.
 2. Carry out self-diagnosis again.
- Does warning lamp activate again?**

No → Inspection end

Yes

A

WHEEL SENSOR ELECTRICAL CHECK

1. Disconnect control unit connector.
2. Check resistance between control unit connector terminals.

Code No. 21 or 22 (Front RH wheel)
Terminals ① and ②

Code No. 25 or 26 (Front LH wheel)
Terminals ④ and ⑤

Code No. 31 or 32 (Rear RH wheel)
Terminals ②④ and ②⑥

Code No. 35 or 36 (Rear LH wheel)
Terminals ⑧ and ⑨

Resistance: 0.9 - 1.1 kΩ

OK → (A) (See next page.)

NG

Note

CHECK WHEEL SENSOR.

Refer to WHEEL SENSOR in Electrical Components Inspection, BR-63.

Note
NG → Replace wheel sensor.

OK

Note

Repair harness and connectors between control unit connector and wheel sensor connector.

Note: Wheel position should be distinguished by code No. except code No. 18 (sensor rotor).

GI
MA
EM
LC
EC
FE
AT
FA
RA
BR
ST
RS
BT
HA
EL
IDX

TROUBLE DIAGNOSES

Diagnostic Procedure 4 (Cont'd)

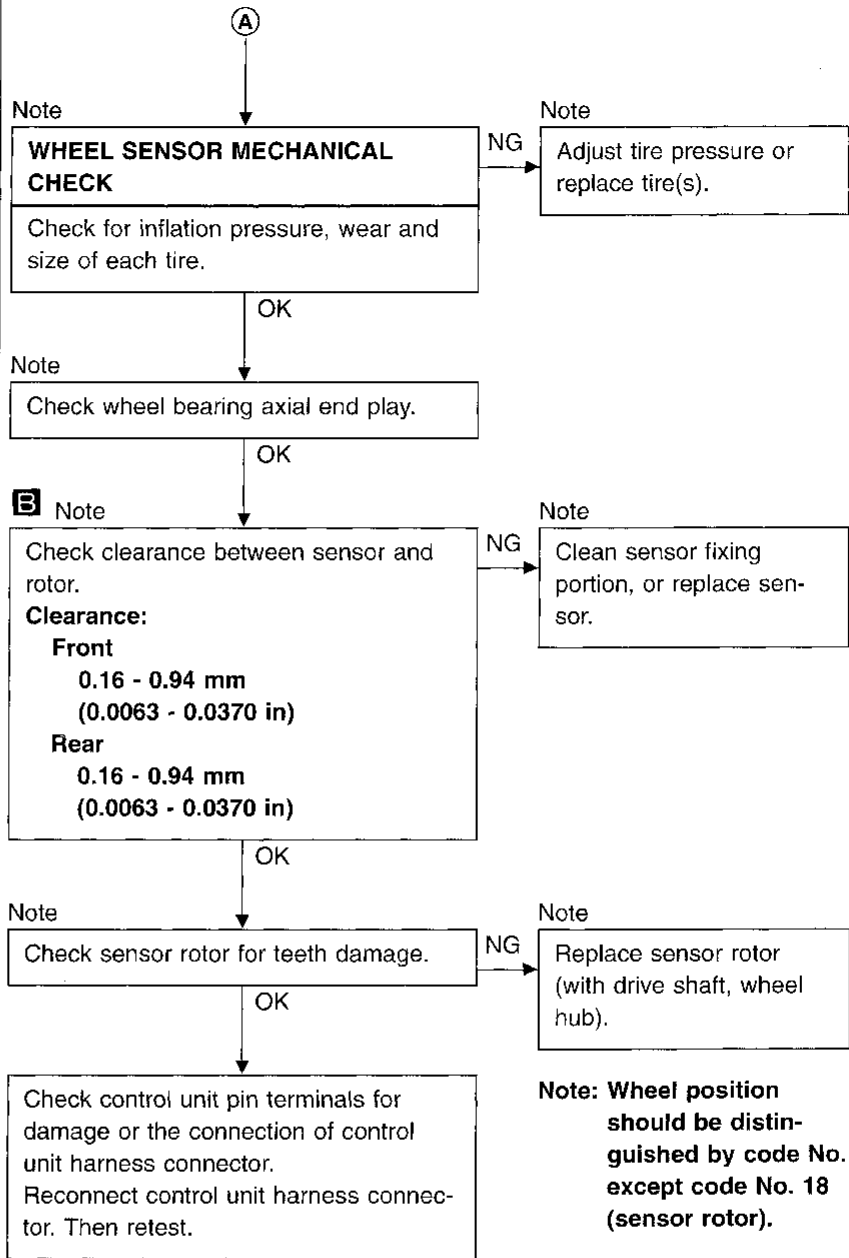
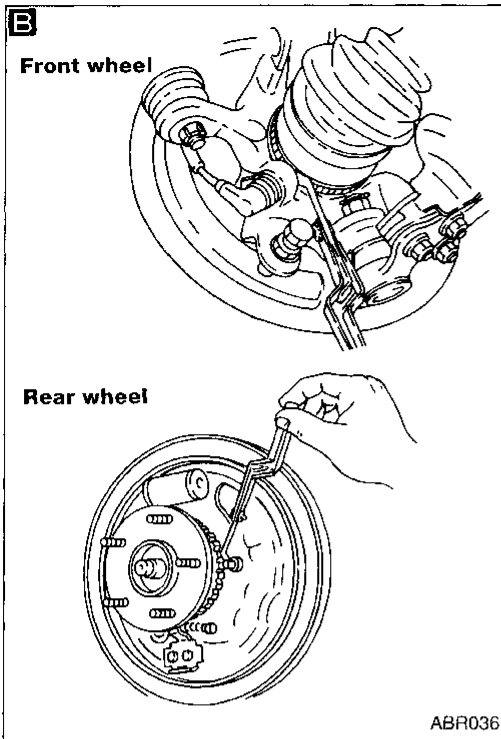

TROUBLE DIAGNOSES

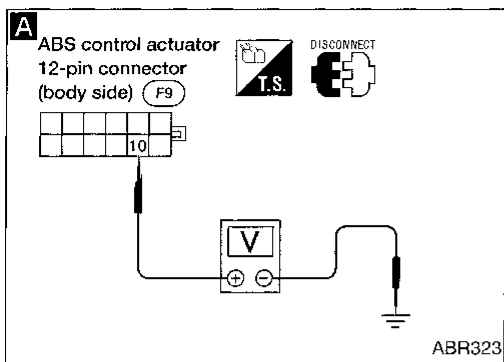

Diagnostic Procedure 5 MOTOR RELAY OR MOTOR (Malfunction code No. 61)

MOTOR POWER SUPPLY CIRCUIT

Check fusible link **D** for ABS control actuator. For fusible link layout, refer to EL section ("POWER SUPPLY ROUTING").

NG (Go to **B** on BR-57.)

OK

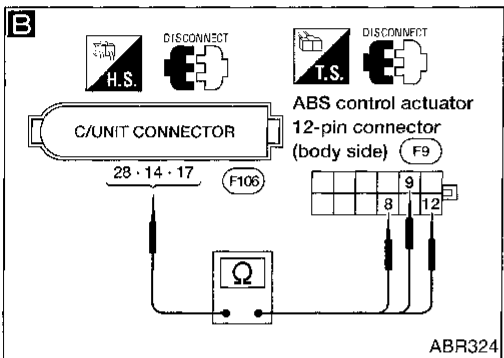

1. Disconnect connectors from control unit and ABS control actuator. Check terminals for damage or loose connections. Then reconnect connectors.
2. Carry out self-diagnosis again.
Does warning lamp activate again?

No Inspection end

Yes

A

1. Disconnect ABS control actuator 12-pin connector.
2. Check voltage between connector (body side) terminal **10** and ground.
Battery voltage should exist.

NG Repair harness and connectors.

OK

B

CIRCUIT CHECK

1. Disconnect ABS control actuator 12-pin connector and control unit connector.
2. Check continuity between control unit connector terminals and ABS control actuator 12-pin connector (body side) terminals.

NG Repair harness and connectors.

Control unit	ABS control actuator
28	12
14	9
17	8

Continuity should exist.

OK

MOTOR RELAY CHECK

Refer to MOTOR RELAY in Electrical Components Inspection, BR-63.

NG Replace motor relay.

OK

MOTOR GROUND CHECK

Refer to ACTUATOR MOTOR GROUND in Ground Circuit Check, BR-46.

NG Repair harness and terminals.

OK

A

(Go to next page.)

TROUBLE DIAGNOSES

Diagnostic Procedure 5 (Cont'd)

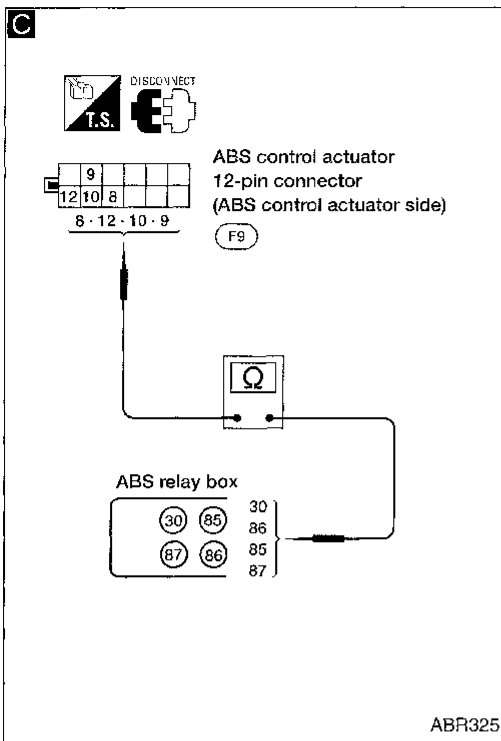

A

C

MOTOR RELAY CIRCUIT

NG → Replace ABS control actuator.

1. Remove motor relay.
2. Check continuity between ABS control actuator 12-pin connector (ABS control actuator side) and ABS relay box terminals.

ABS control actuator connector	ABS relay box terminal
⑧	⑧6
⑫	⑧5
⑩	③0
⑨	⑧7

Continuity should exist.

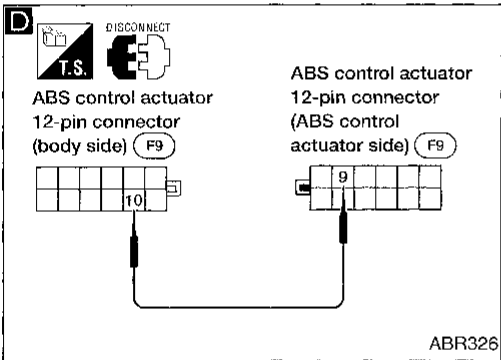

D

MOTOR CHECK

NG → Replace ABS control actuator.

1. Disconnect ABS control actuator 12-pin connector.
2. Apply battery voltage to motor by connecting ABS control actuator 12-pin connector terminal ⑩ (body side) to terminal ⑨ (ABS control actuator side).

Motor should operate.
Do not connect wire for more than 5 seconds.

OK → Inspection end

TROUBLE DIAGNOSES

Diagnostic Procedure 5 (Cont'd)

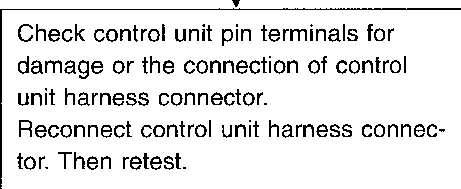
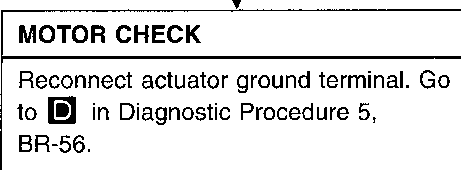
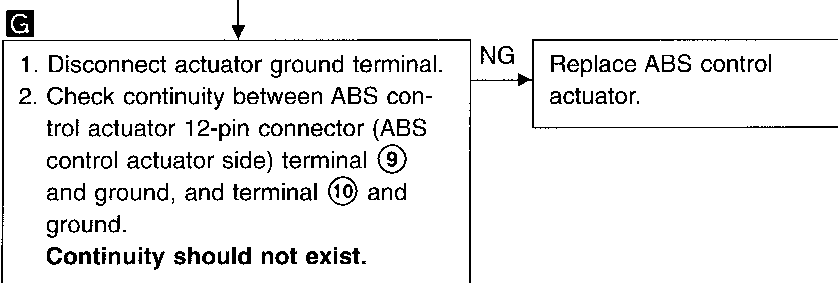
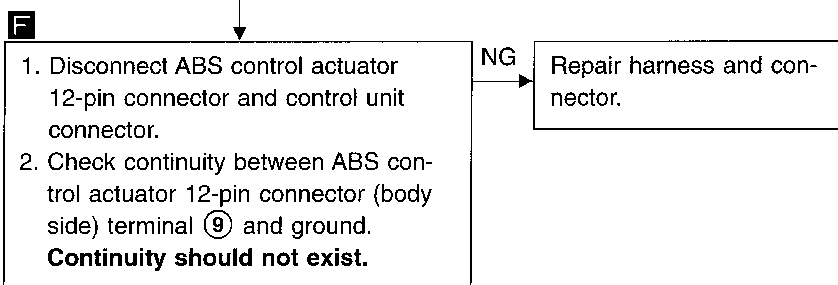
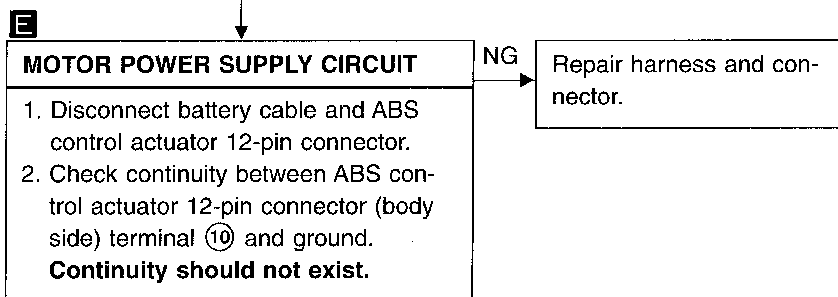
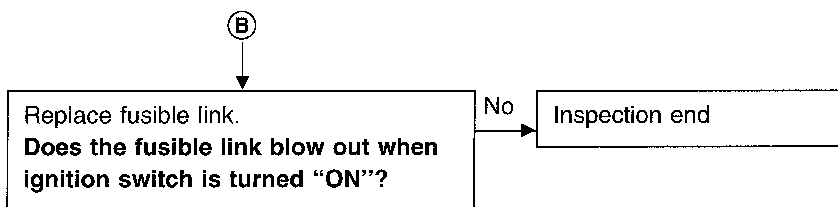
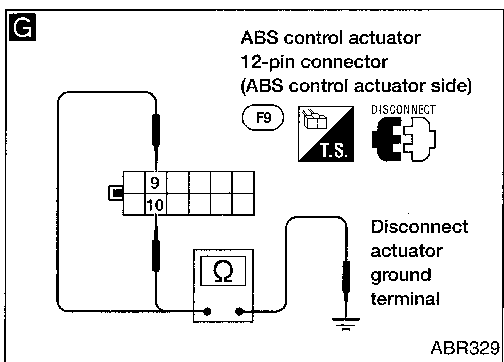
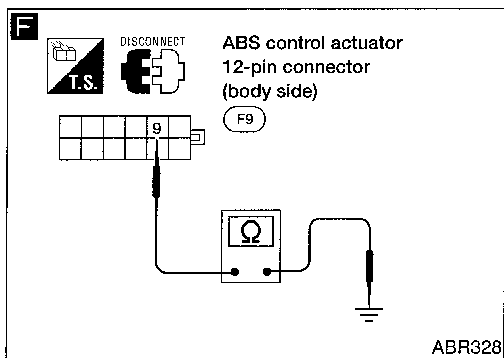
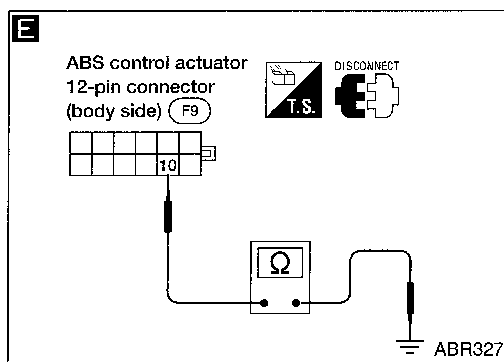

GI
MA
EW
LC
EC
FE
AT
FA
RA
BR
ST
RS
BT
HA
EL
ICX

Diagnostic Procedure 6 SOLENOID VALVE RELAY (Malfunction code No. 63)

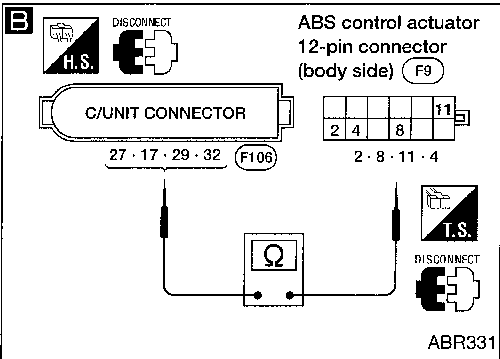
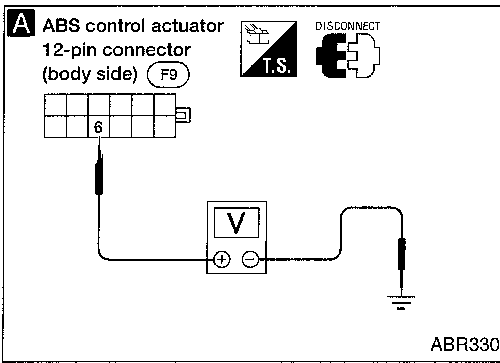

SOLENOID VALVE POWER SUPPLY CHECK

Check 20A fuse [43]. For fuse layout, refer to BR-42.

NG → **A** (See next page.)

OK

1. Disconnect connectors from control unit and ABS control actuator. Check terminals for damage or loose connections. Then reconnect connectors.
2. Carry out self-diagnosis again.
Does warning lamp activate again?

No → Inspection end

Yes

GROUND CIRCUIT CHECK

Refer to CONTROL UNIT GROUND and ACTUATOR MOTOR GROUND in Ground Circuit Check, BR-46.

NG → Repair harness and connectors.

OK

A SOLENOID VALVE POWER SUPPLY CHECK

1. Disconnect 12-pin connector from ABS control actuator.
2. Check voltage between ABS control actuator 12-pin connector (body side) terminal (6) and ground.
Battery voltage should exist.

NG → Repair harness and connector.

OK

- B**
- ### CIRCUIT CHECK
1. Disconnect control unit connector.
 2. Check continuity between control unit connector terminals and ABS control actuator 12-pin connector (body side) terminals.

NG → Repair harness and connectors.

Control unit	ABS control actuator
(27)	(2)
(17)	(8)
(29)	(11)
(32)	(4)

Continuity should exist.

OK

SOLENOID VALVE RELAY CHECK

Refer to SOLENOID VALVE RELAY in Electrical Components Inspection, BR-63.

NG → Replace solenoid valve relay.

OK

B
(Go to next page.)

TROUBLE DIAGNOSES

Diagnostic Procedure 6 (Cont'd)

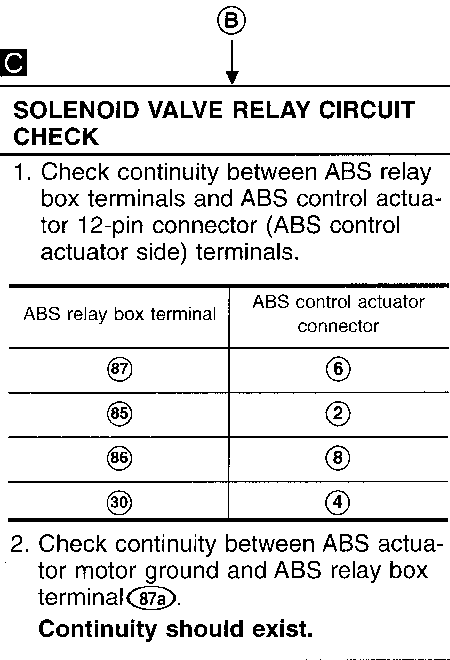
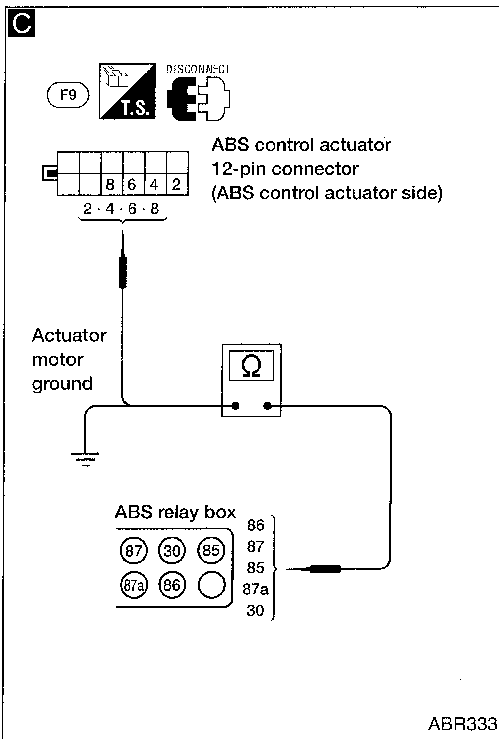

NG → Replace ABS control actuator.

OK → Go to diagnostic procedure 3, BR-51.

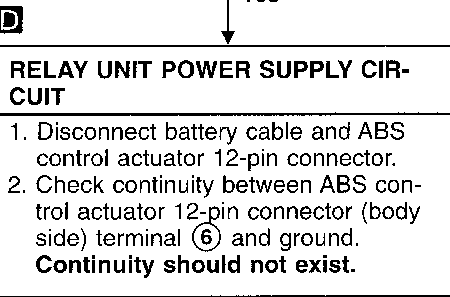
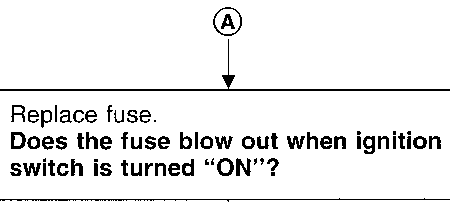
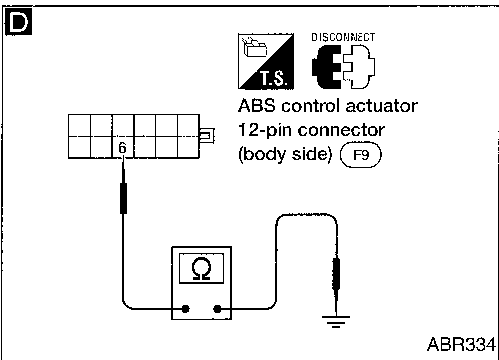

NG → Repair harness and connector.

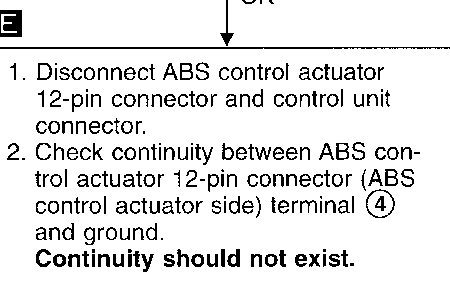
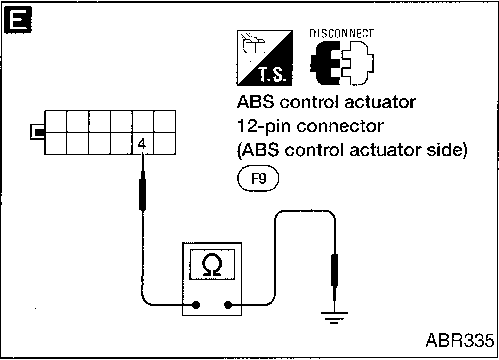

NG → Replace ABS control actuator.

OK → Go to Diagnostic Procedure 3, BR-51.

CI
MA
EM
LG
EC
FE
AT
FA
RA
BR
ST
RS
BT
HA
EL
IDX

Diagnostic Procedure 7

CONTROL UNIT

(Malfunction code No. 71)

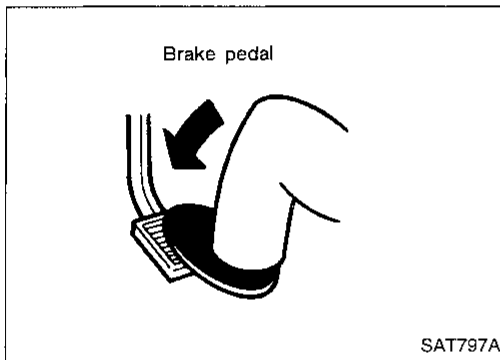
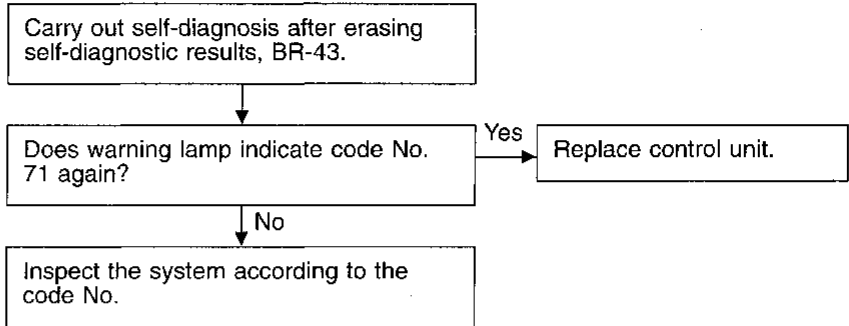

Diagnostic Procedure 8

SYMPTOM: Pedal vibration and noise

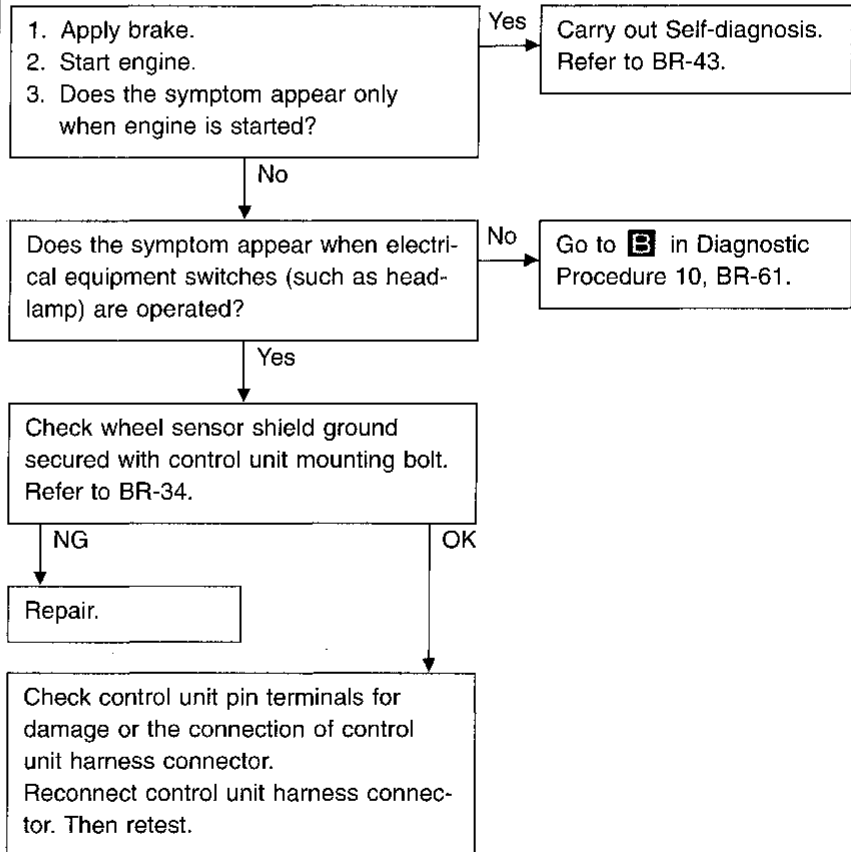

Note: ABS may operate and cause vibration under any of the following conditions.

- Low friction (slippery) road.
- High speed cornering.
- Driving over bumps and pot holes.
- Engine speed is over 5,000 rpm with vehicle stopped.

Diagnostic Procedure 9

SYMPTOM: Long stopping distance

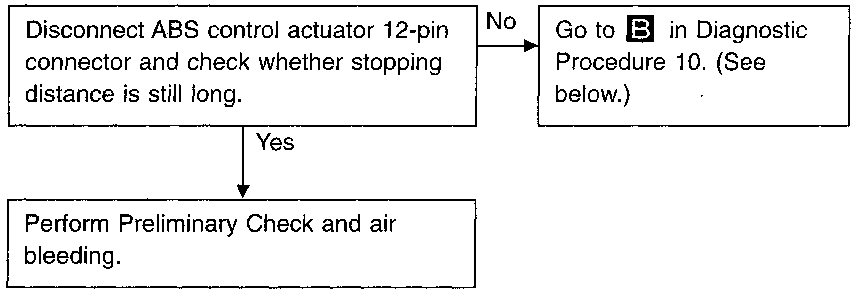

Note: Stopping distance may be longer than that of vehicles without ABS when road condition is slippery.

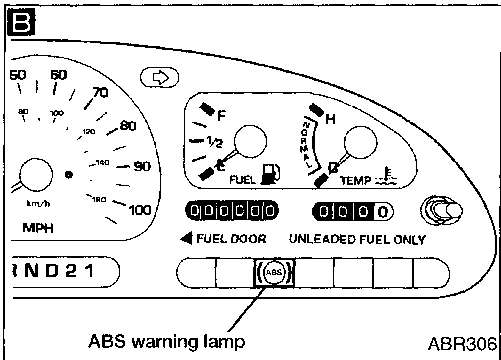
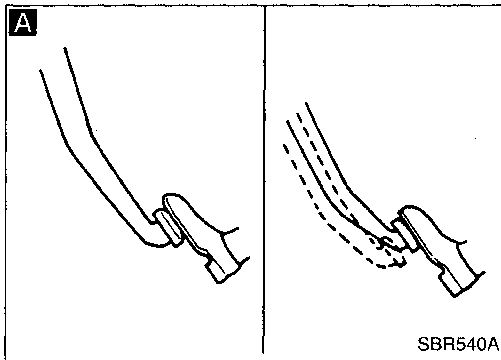

Diagnostic Procedure 10

SYMPTOM: Unexpected pedal action

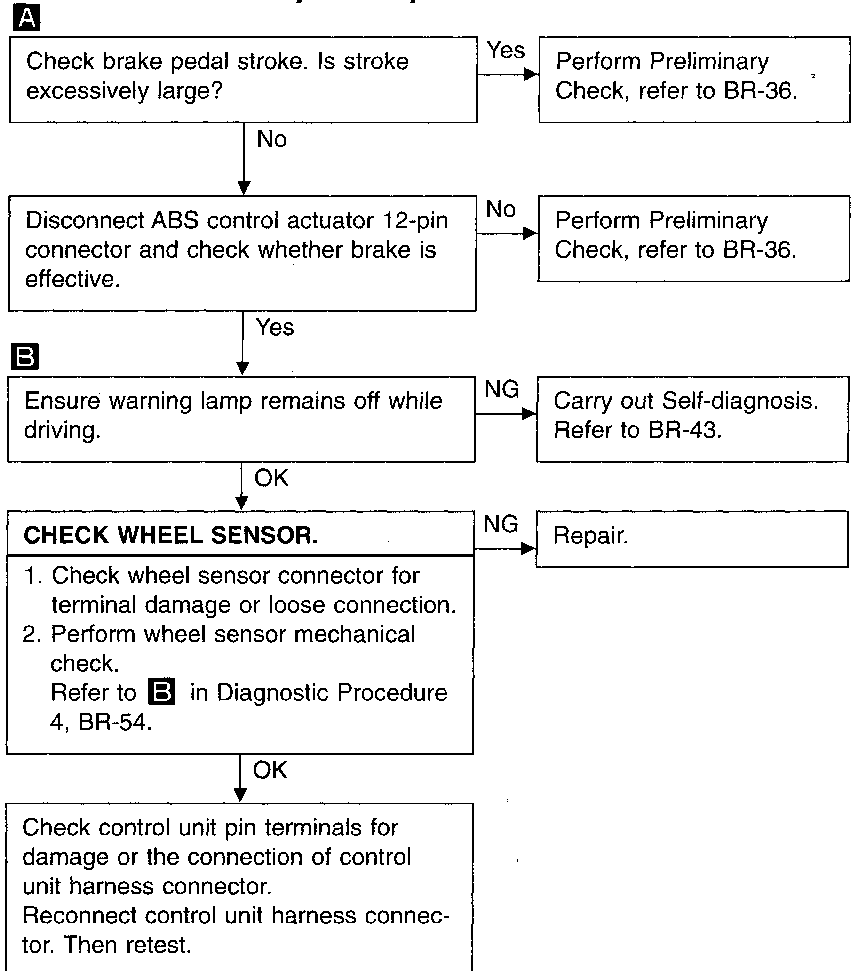

Diagnostic Procedure 11

SYMPTOM: ABS does not work.

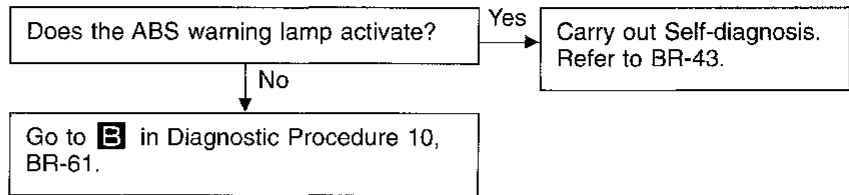

Note: ABS does not work when vehicle speed is under 10 km/h (6 MPH).

Diagnostic Procedure 12

SYMPTOM: ABS works frequently.

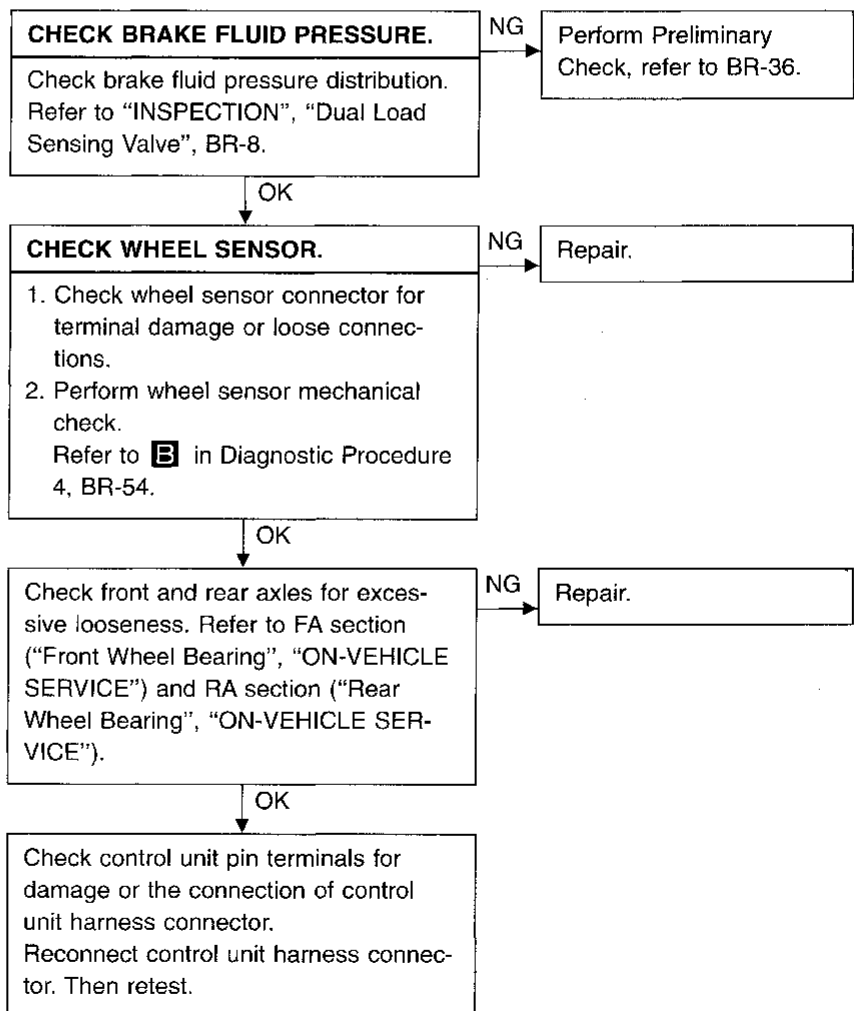

TROUBLE DIAGNOSES

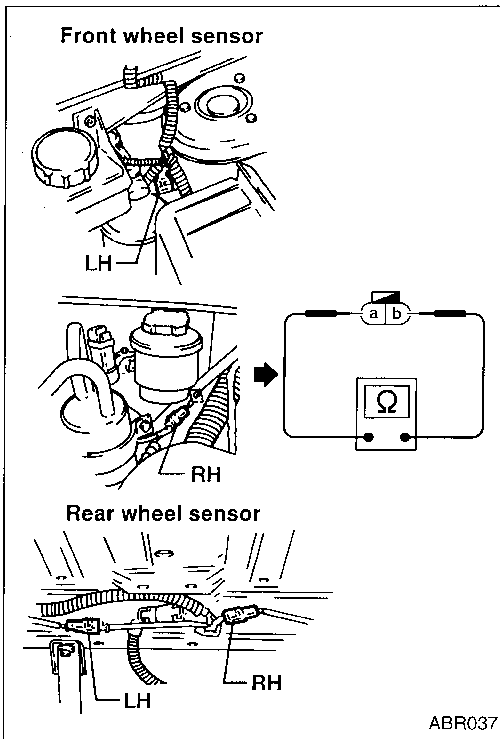

Electrical Components Inspection

WHEEL SENSOR

Check resistance for each sensor.

Resistance: 0.9 - 1.1 kΩ

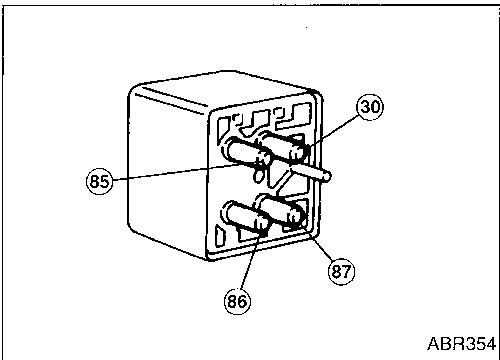

MOTOR RELAY

Condition	Continuity existence between terminals ③① and ⑧⑦
Battery voltage not applied between terminals ⑧⑤ and ⑧⑥.	No
Battery voltage applied between terminals ⑧⑤ and ⑧⑥.	Yes

While applying battery voltage to relay terminals, insert fuse into the circuit.

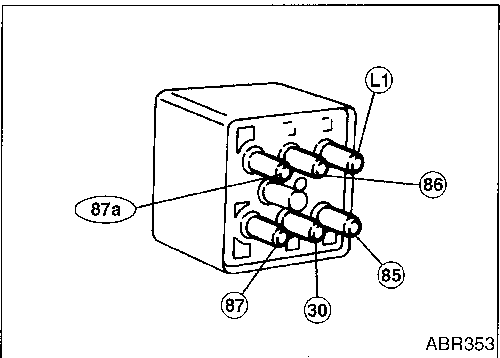

SOLENOID VALVE RELAY

Condition	Continuity existence between terminals ③① and ⑧⑦a	Continuity existence between terminals ③① and ⑧⑦
Battery voltage not applied between terminals ⑧⑤ and ⑧⑥.	Yes	No
Battery voltage applied between terminals ⑧⑤ and ⑧⑥.	No	Yes

While applying battery voltage to relay terminals, insert fuse into the circuit.

GI
NA
EM
LC
EC
FE
AT
FA
RA
BR
ST
RS
BT
HA
EL
IDX

SERVICE DATA AND SPECIFICATIONS (SDS)

General Specifications

Front brake	
Brake model	AD28VX
Cylinder bore diameter mm (in)	60.0 (2.362)
Pad length x width x thickness mm (in)	144.0 x 44.9 x 9.67 (5.67 x 1.768 x 0.3807)
Rotor outer diameter x thickness mm (in)	277 x 26 (10.91 x 1.02)
Rear brake	
Brake model	LT25X
Cylinder bore diameter mm (in)	25.40 (1)
Lining length x width x thickness mm (in)	247.5 x 55.0 x 5.9 (9.74 x 2.165 x 0.232)
Drum inner diameter mm (in)	250 (9.84)

Master cylinder	
Cylinder bore diameter mm (in)	25.40 (1)
Control valve	
Valve model	Dual load sensing valve
Split point [kPa (kg/cm ² , psi)] x reducing ratio	Variable x 0.3
Brake booster	
Booster model	M215T
Diaphragm diameter mm (in)	Primary: 230 (9.06) Secondary: 205 (8.07)
Brake fluid	
Recommended brake fluid	DOT 3

Inspection and Adjustment

DISC BRAKE

Unit: mm (in)

Pad wear limit	
Minimum thickness	2.0 (0.079)
Rotor repair limit	
Minimum thickness	24.0 (0.945)

DRUM BRAKE

Unit: mm (in)

Lining wear limit	
Minimum thickness	2.0 (0.079)
Drum repair limit	
Maximum inner diameter	251.5 (9.90)

BRAKE PEDAL

Unit: mm (in)

Free height "H"	195 - 205 (7.68 - 8.07)
Depressed height "D" [under force of 490 N (50 kg, 110 lb) with engine running]	115 - 130 (4.53 - 5.12)
Clearance "C" between pedal stopper and threaded end of stop lamp switch or ASCD switch	0.3 - 1.0 (0.012 - 0.039)
Pedal free play	1.0 - 3.0 (0.039 - 0.118)

PARKING BRAKE

Unit: Number of notches

Control type	Foot lever
Pedal stroke [under force of 196 N (20 kg, 44 lb)]	11 - 12