

SECTION BT

GI
MA
EM
LC
EC
FE
AT
FA
RA
BR
ST
RS
BT
HA
EL
IDX

CONTENTS

PRECAUTIONS	2	⑦ Body side drip molding	30
Supplemental Restraint System (SRS)		⑧ Waist rail finisher	30
“AIR BAG”	2	⑨ Front door weatherstrip	30
GENERAL SERVICING	3	⑩ Sliding door weatherstrip	30
Clip and Fastener	3	⑪ Sliding door lower seal	30
BODY END	6	⑫ Back door opening weatherstrip	30
Body Front End	6	⑬ Luggage rack	31
Removal — Front bumper assembly	6	⑭ Outside door molding	32
Bumper Shock Absorber Inspection	9	⑮ Front door corner covers	33
Body Rear End and Opener	10	⑯ Side guard molding	33
Removal — Rear bumper assembly	10	SEAT	34
Bumper Shock Absorber Inspection — Rear ...	10	Front Seat	34
DOOR	13	Front Power Seat	35
Front Door	13	2nd Seat	36
Sliding Door	14	3rd Seat	38
Rear Door	16	SUNROOF	43
INSTRUMENT PANEL	18	Trouble Diagnoses	46
INTERIOR TRIM	22	WINDSHIELD AND WINDOWS	51
Side and Floor Trim	22	Windshield and Rear Window	52
Roof Trim	26	Repairing Water Leaks For Windshield	52
EXTERIOR	28	Side Window (1st)	53
① Hood front sealing rubber	29	Side Window (2nd)	54
② ③ Hood rear sealing rubber		MIRROR	55
and cowl top grille	29	Door Mirror	55
④ Sun roof frame weatherstrip and		Rearview Mirror	56
sun roof lid weatherstrip	29	BODY ALIGNMENT	57
⑤ Windshield upper molding	29	Engine Compartment	58
⑥ Windshield side molding	29	Underbody	60

PRECAUTIONS

- When removing or installing various parts, place a cloth or padding on the vehicle body to prevent scratches.
- Handle trim, molding, instruments, grille, etc., carefully during removing or installation. Be careful not to soil or damage them.
- Apply sealing compound where necessary when installing parts.
- When applying sealing compound, be careful that the sealing compound does not protrude from parts.
- When replacing any metal parts (for example, body outer panel, members, etc.), be sure to take rust prevention measures.

Supplemental Restraint System (SRS) “AIR BAG”

The Supplemental Restraint System “AIR BAG”, used along with a seat belt, helps to reduce the risk or severity of injury to the driver and front passenger in a frontal collision. The Supplemental Restraint System consists of air bag modules (located in the center of the steering wheel and in the instrument panel on the passenger side), a diagnosis sensor unit, warning lamp, wiring harness and spiral cable. Information necessary to service the system safely is included in the **RS section** of this Service Manual.



WARNING:

- **To avoid rendering the SRS inoperative, which could increase the risk of personal injury or death in the event of a collision which would result in air bag inflation, all maintenance should be performed by an authorized NISSAN dealer.**
- **Improper maintenance, including incorrect removal and installation of the SRS, can lead to personal injury caused by unintentional activation of the system.**
- **Do not use electrical test equipment on any circuit related to the SRS unless instructed to in this Service Manual. SRS wiring harnesses are covered with yellow insulation either just before the harness connectors or on the complete harness, for easy identification.**

GENERAL SERVICING

Clip and Fastener

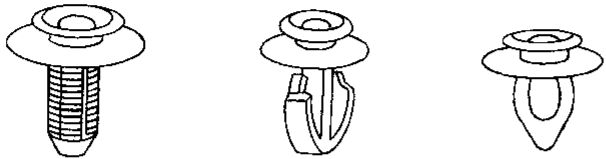
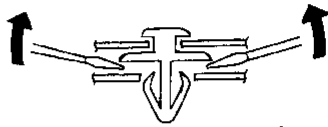
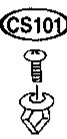
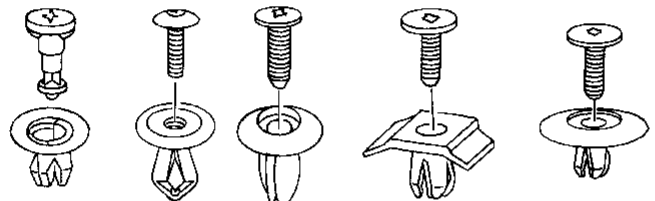
- Clips and fasteners in BT section correspond to the following numbers and symbols.
- Replace any clips and/or fasteners which are damaged during removal or installation.

Symbol No.	Shapes	Removal & Installation
 <p>C101</p>	 <p style="text-align: right;">SBF302H</p>	<p>Removal: Remove by bending up with flat-bladed screwdrivers or clip remover.</p>  <p style="text-align: right;">SBF367BA</p>
 <p>CS101</p>	 <p style="text-align: right;">SBF078B</p>	<p>Removal: Screw out with a Phillips screwdriver.</p> <p>Remove female portion with flat-bladed screwdriver.</p>  <p style="text-align: right;">ABF172</p>

GI

MA

EM

LC

EC

FE

AT

FA

RA

BR

ST

RS

BT







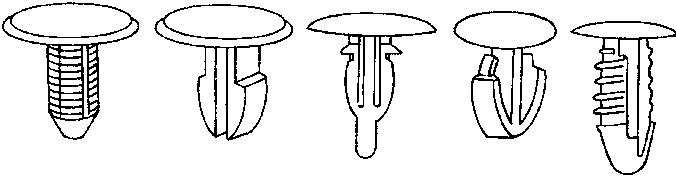
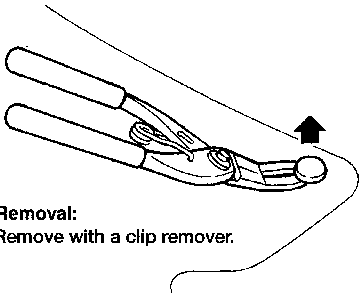

HA

EL

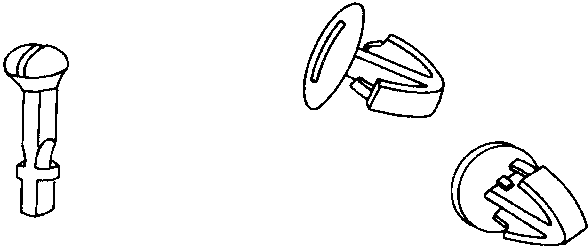
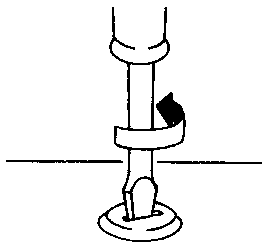
IDX

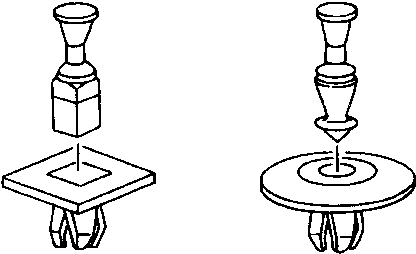
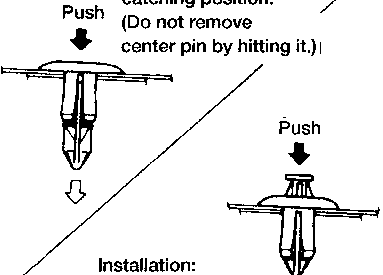

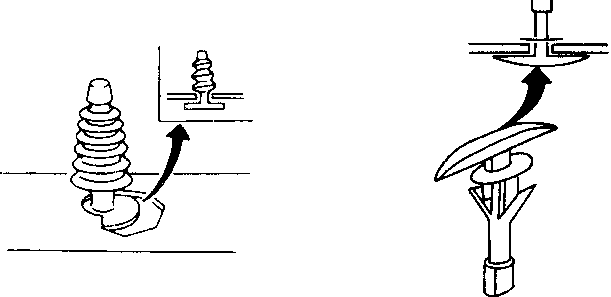
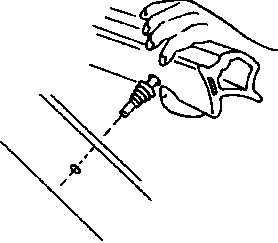

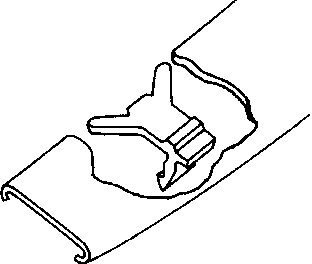
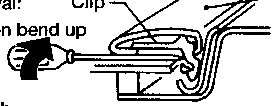
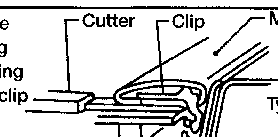





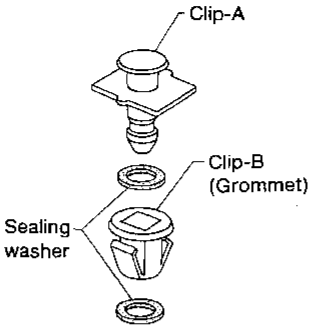
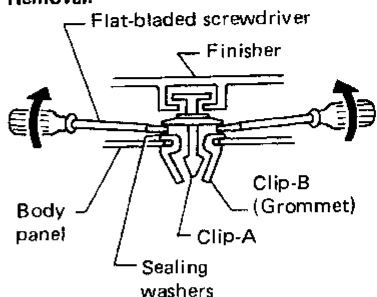

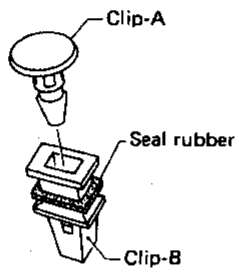
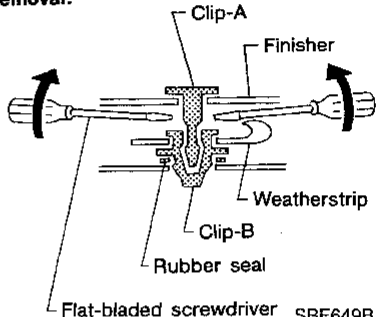

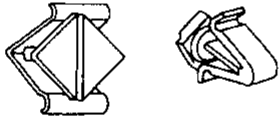
GENERAL SERVICING

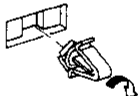
Clip and Fastener (Cont'd)

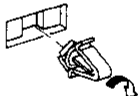
Symbol No.	Shapes	Removal & Installation
		 <p>Removal: Remove with a clip remover.</p>
		
		<p>Push center pin to catching position. (Do not remove center pin by hitting it.)</p>  <p>Installation:</p>
		
		<p>Removal: Clip Molding</p> <p>② Then bend up</p>  <p>Type 1</p> <p>① Push</p> <p>Remove molding by cutting off the clip</p>  <p>Type 2</p>

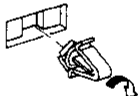
GENERAL SERVICING

Clip and Fastener (Cont'd)

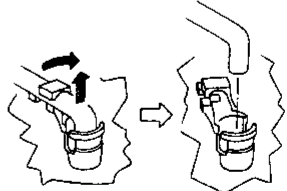
Symbol No.	Shapes	Removal & Installation				
<p>CF118</p> 		<p>Removal:</p>  <p>SBF151D</p> <p style="text-align: right;">SBF259G</p>				
<p>CF110</p> 		<p>Removal:</p>  <p>SBF648B</p> <p style="text-align: right;">SBF649B</p>				
<p>CG101</p> 		<table border="1" style="width: 100%; border-collapse: collapse;"> <tr> <td style="width: 50%; padding: 5px;"> <p>Removal:</p>  <p style="text-align: center;">Rotate 45° to remove.</p> </td> <td style="width: 50%; padding: 5px;"> <p>Installation:</p>  </td> </tr> <tr> <td colspan="2" style="padding: 5px;"> <p>Removal:</p>  </td> </tr> </table> <p>SBF145B</p> <p style="text-align: right;">SBF085B</p>	<p>Removal:</p>  <p style="text-align: center;">Rotate 45° to remove.</p>	<p>Installation:</p> 	<p>Removal:</p> 	
<p>Removal:</p>  <p style="text-align: center;">Rotate 45° to remove.</p>	<p>Installation:</p> 					
<p>Removal:</p> 						
<p>CR103</p> 		<p>Removal: Holder portion of clip must be spread out to remove rod.</p>  <p>SBF768B</p> <p style="text-align: right;">SBF770B</p>				

GI
MA
EM
LC
EC
FE
AT
FA
RA
BR
ST
RS
BT
HA
EL
IDX

Body Front End

- Bumper fascia: It is made of plastic. Do not use excessive force. Keep oil away from it.
- Hood: When removing or installing hood, place a cloth or other padding on front fender panels and cowl top. This prevents vehicle body from being scratched.
- Hood adjustment: Adjust at hinge portion.
- Hood lock adjustment: After adjusting, check hood lock control operation. Apply a coat of grease to hood lock engaging mechanism.
- Hood opener: Do not attempt to bend cable forcibly.

REMOVAL — Front bumper assembly

- Headlamps must be removed prior to removal of front bumper assembly.
- ① Remove two clips (CS101) securing top of grille assembly and two screws securing top of turn signals.
- ② Remove three clips (CG101) from lower center grille and below turn signals.
- ③ Remove grille assembly and disconnect turn signal electrical connectors.
- ④ Remove four bolts securing fascia retainer to closing plates.
- ⑤ Remove two clips (CS101) securing bumper fascia to fender bracket.
- ⑥ Remove one clip (CS101) and two retainers (C103) securing center of bumper fascia to bottom of bumper reinforcement.
- ⑦ Remove three clips (CS101) securing bumper fascia to fender protector on each side.
- ⑧ Remove two screws and one nut securing bumper fascia to fender on each side.
- ⑨ Remove clip (CS101) securing center of bumper fascia to hood latch support.
- ⑩ Remove bumper fascia from vehicle.
- ⑪ Remove six bolts securing bumper reinforcement to bumper shock absorber supports.
- ⑫ Remove six bolts securing bumper shock absorber supports to the side members.
- ⑬ If necessary remove ten clips (CS101) securing bumper fascia to fascia retainer.

BODY END

Body Front End (Cont'd)

SEC. 260•262•620•623

Hood lock adjustment

- Adjust lock so that hood primary lock meshes at a position where hood is 1 to 1.5mm (0.039 to 0.059 in) lower than fender.
- After hood lock adjustment, adjust bumper rubber.
- When securing hood lock, make sure it does not tilt. Striker must be positioned at the center of hood primary lock.
- After adjustment, make sure that hood primary and secondary locks operate properly.

Hood lock secondary latch hooking length:

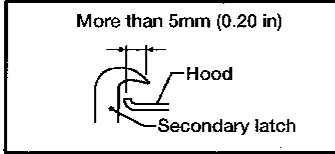

Bumper rubber adjustment

- Adjust so that hood is aligned with fender.
- [Bumper rubber free height is approx. 13mm (0.51 in)]

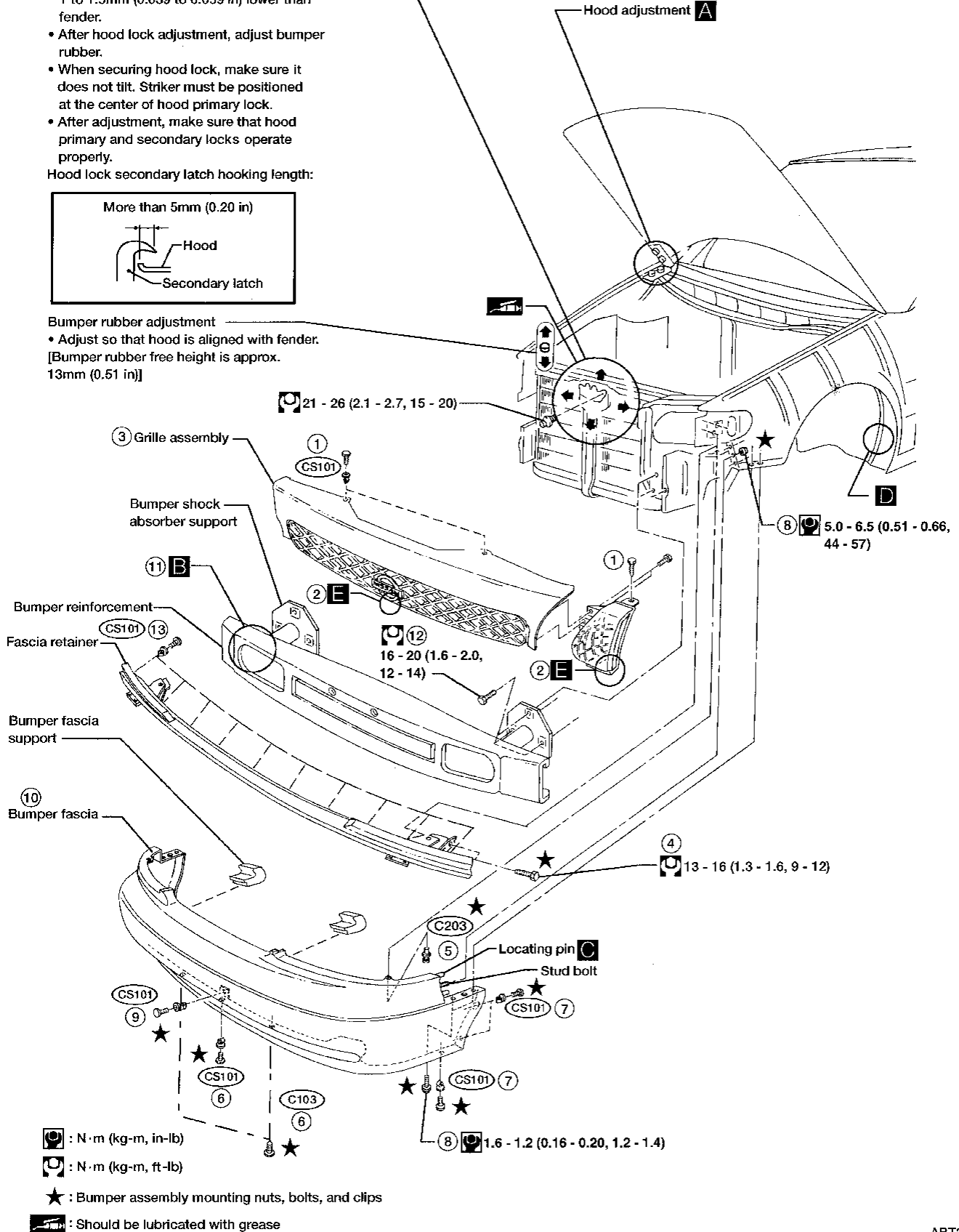

GI
MA
EM
LC
EC
FE
AT
FA
RA
BR
ST
RS
BT
HA
EL
IDX

BODY END

Body Front End (Cont'd)

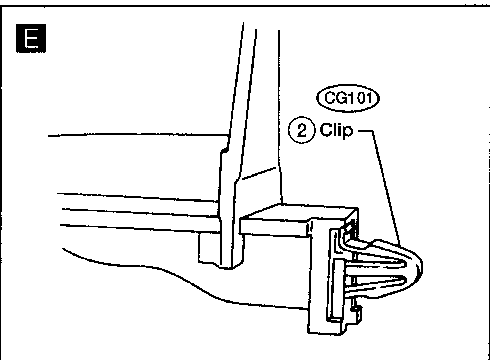
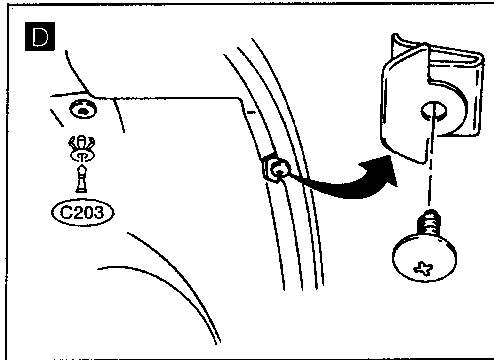
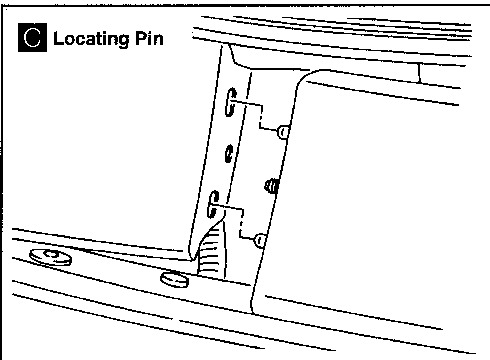
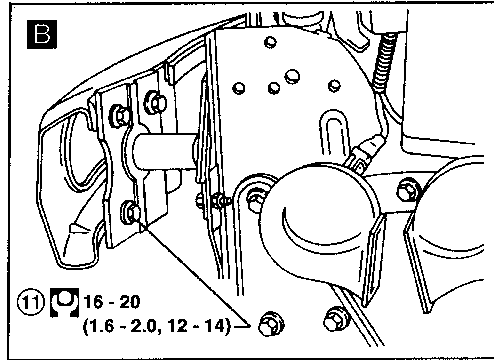
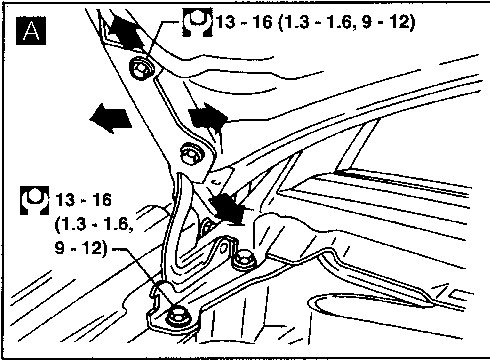

 : N·m (kg-m, ft-lb)

ABT146

BODY END

Body Front End (Cont'd)

BUMPER SHOCK ABSORBER INSPECTION

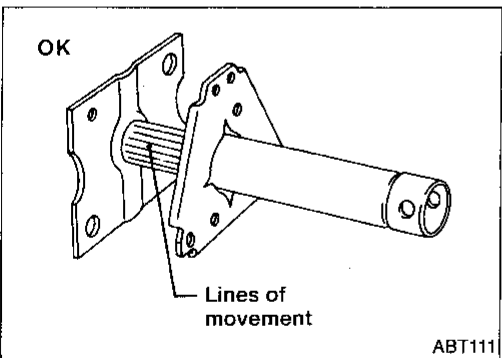
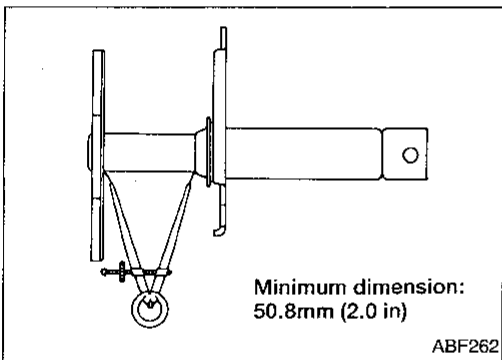
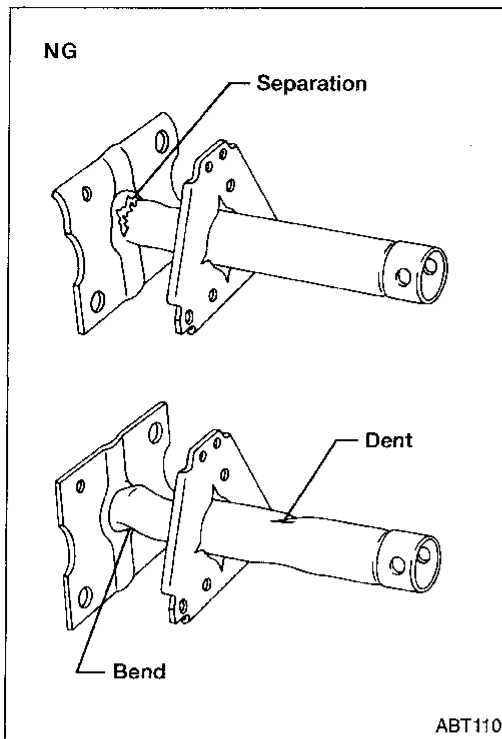

1. Inspect the absorber unit for any deformation. It is acceptable to repair a bent mounting bracket using a cold straightening method. If damage is apparent, such as a separation, dent, or bend, replace the absorber unit.

GI

MA

EM

LC

EC

FE

AT

FA

2. Measure the distance of the absorber unit shaft between the mounting brackets.

Minimum acceptable dimension:

50.8 mm (2.0 in)

If the dimension is less than acceptable, replace the absorber unit.

RA

BR

3. Lines of movement on the absorber unit shaft are acceptable only if the dimension of the shaft meets the requirements described above.

ST

RS

4. When installing, tighten the mounting bracket bolts to specification.

BT

Body front end:

: 13 - 16 N·m (1.3 - 1.6 kg-m, 9 - 2 ft-lb)

Body rear end:

: 31 - 42 N·m (3.2 - 4.3 kg-m, 23 - 31 ft-lb)

HA

EL

IDX

BODY END

Body Rear End and Opener

- Back door adjustment: Adjust at hinge for proper back door fit.
- Back door lock system adjustment: Adjust lock and striker so that they are in the center. After adjustment, check back door lock operation.
- Before removing bumper, remove side marker lamps.
- Opener cable: Do not attempt to bend cable forcibly.

WARNING:

- Be careful not to scratch back door stay and/or back door hatch stay when installing back door and/or back door hatch. A scratched stay may cause gas leakage.
- The contents of the back door stay and back door hatch stay are under pressure. Do not take apart, puncture, apply heat or allow fire near them.

REMOVAL — Rear bumper assembly

- ① Remove seven clips (CS101) securing bumper fascia to body.
- ② Remove six nuts securing bumper fascia to body.
- ③ Remove four clips (C203) securing front of bumper fascia to fender opening.
- ④ Remove four screws securing bottom of bumper fascia to fascia stay.
- ⑤ Remove seven clips (CS101) securing bottom of bumper fascia to bumper reinforcement.
- ⑥ Remove side marker lamps.
- ⑦ Remove bumper fascia.
- ⑧ Remove six bolts securing bumper reinforcement to shock absorbers.
- ⑨ Remove bumper reinforcement.
- ⑩ Remove six bolts securing shock absorbers to body, then remove shock absorbers.

BUMPER SHOCK ABSORBER INSPECTION — Rear

The rear bumper shock absorber inspection is the same as the front bumper shock absorber inspection. Refer to "BUMPER SHOCK ABSORBER INSPECTION", "Body Front End, BT- 9".

BODY END

Body Rear End and Opener (Cont'd)

SEC. 262•850•900

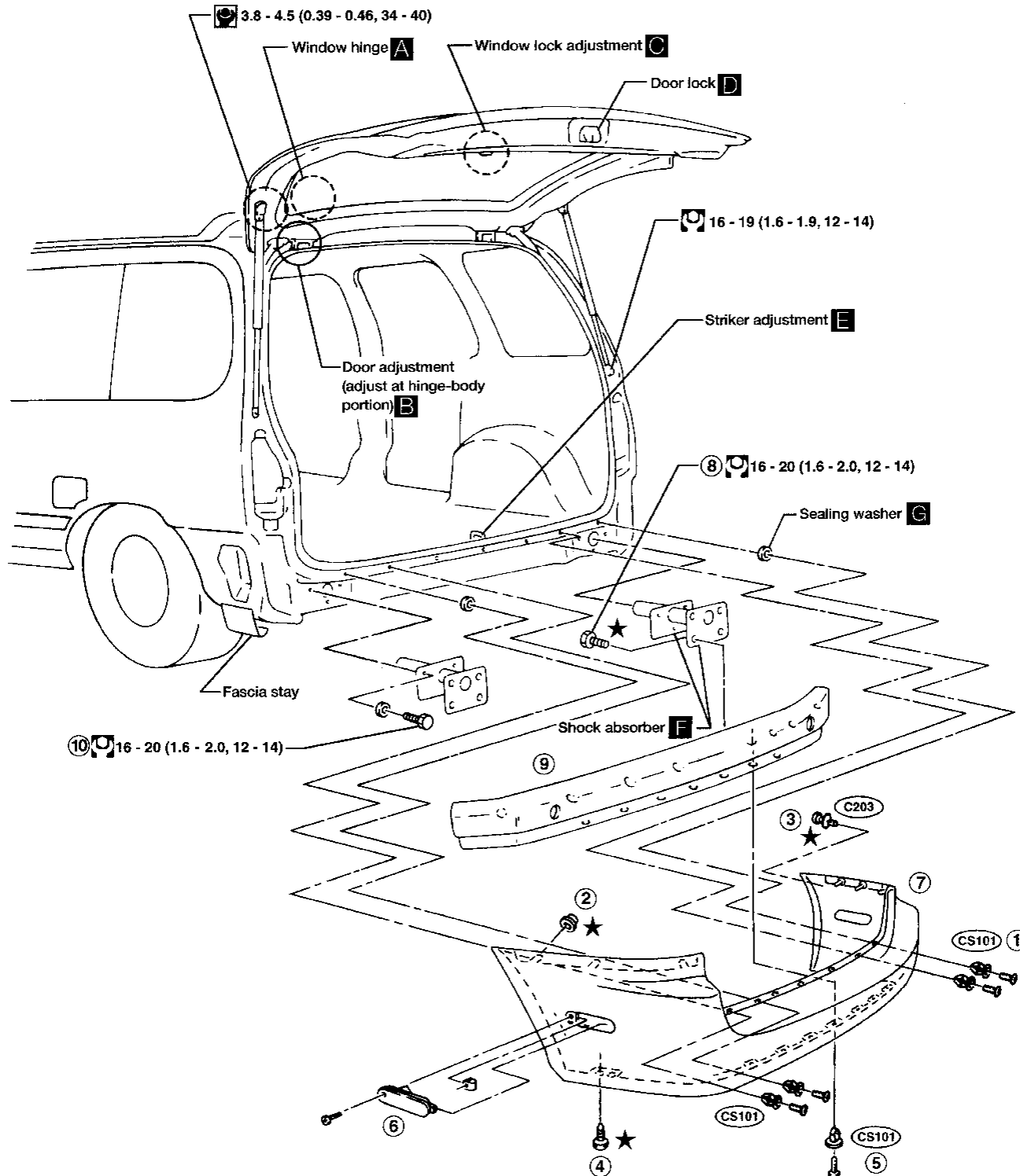

: N·m (kg-m, in-lb)

: N·m (kg-m, ft-lb)

★ : Bumper assembly mounting nuts, bolts, and clips

GI
MA
EM
LC
EC
FE
AT
FA
RA
BR
ST
RS
BT
HA
EL
IDX

BODY END

Body Rear End and Opener (Cont'd)

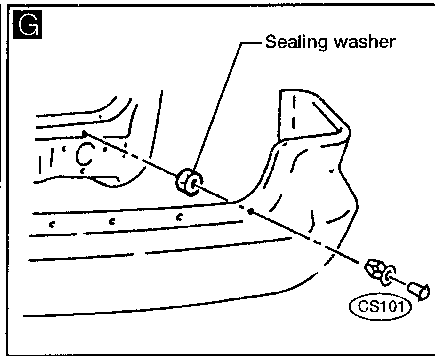
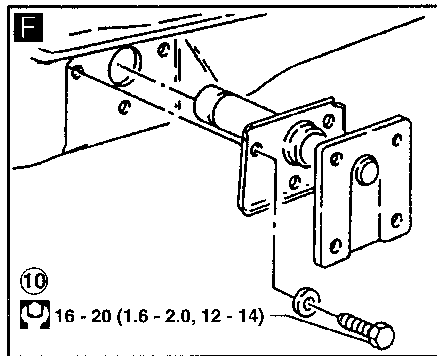
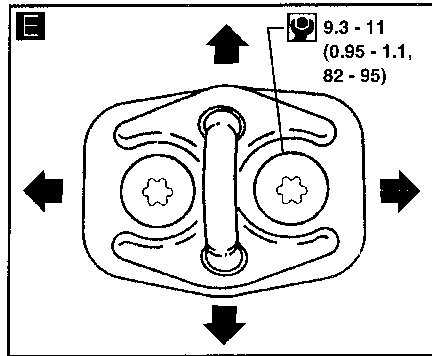
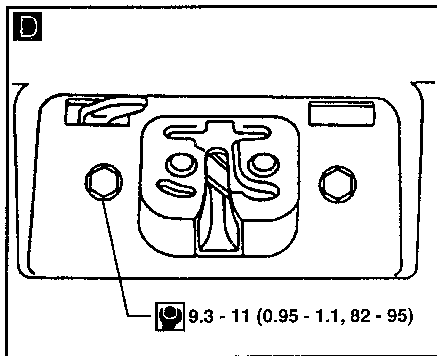
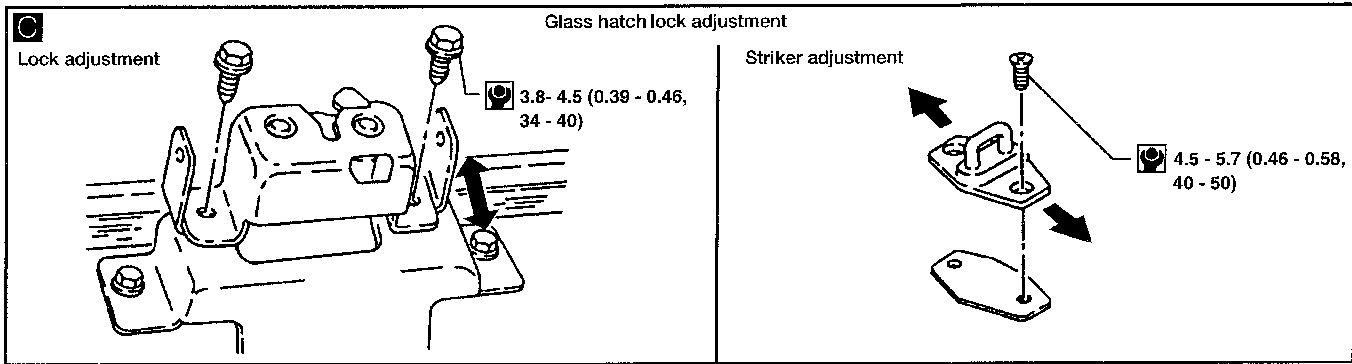
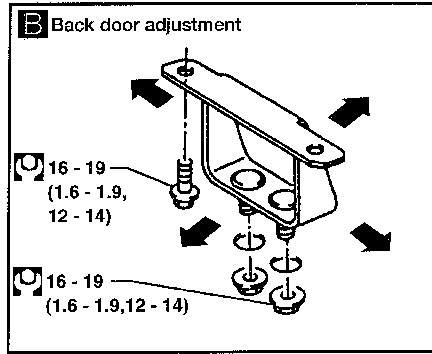
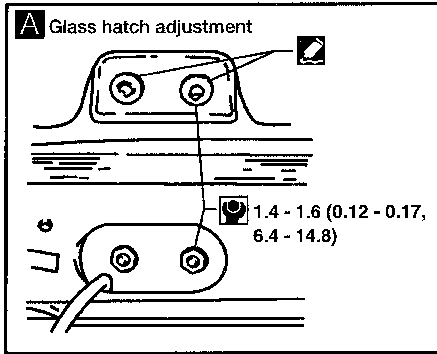

: N·m (kg-m, in-lb)
 : N·m (kg-m, ft-lb)

DOOR

Front Door

- For removal of door trim, refer to BT-24 ("Door Trim", "INTERIOR TRIM").
- After adjusting door or door lock, check door lock operation.

SEC. 800•803•805•998

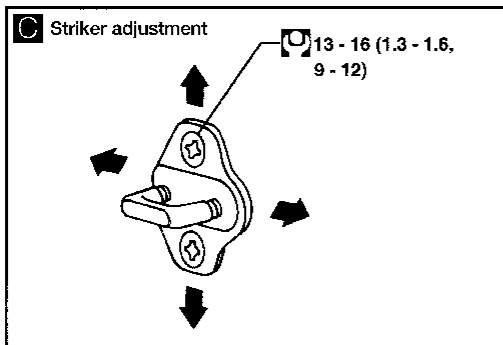
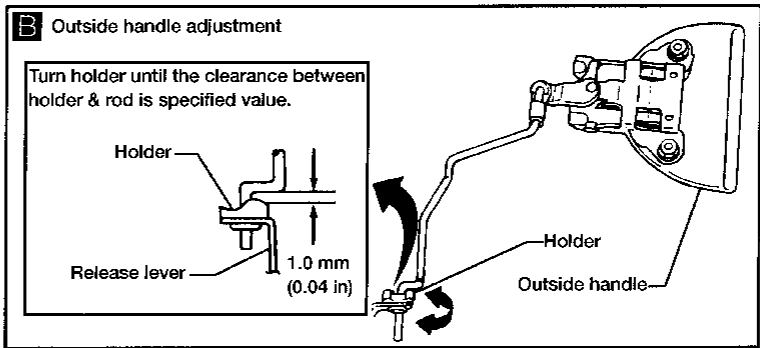
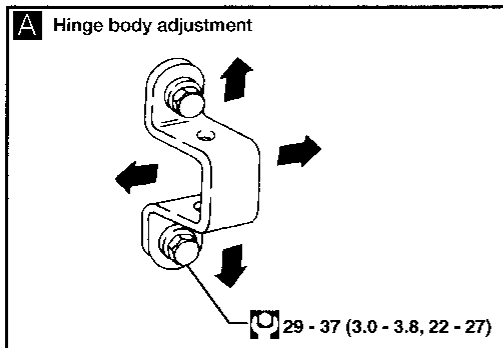
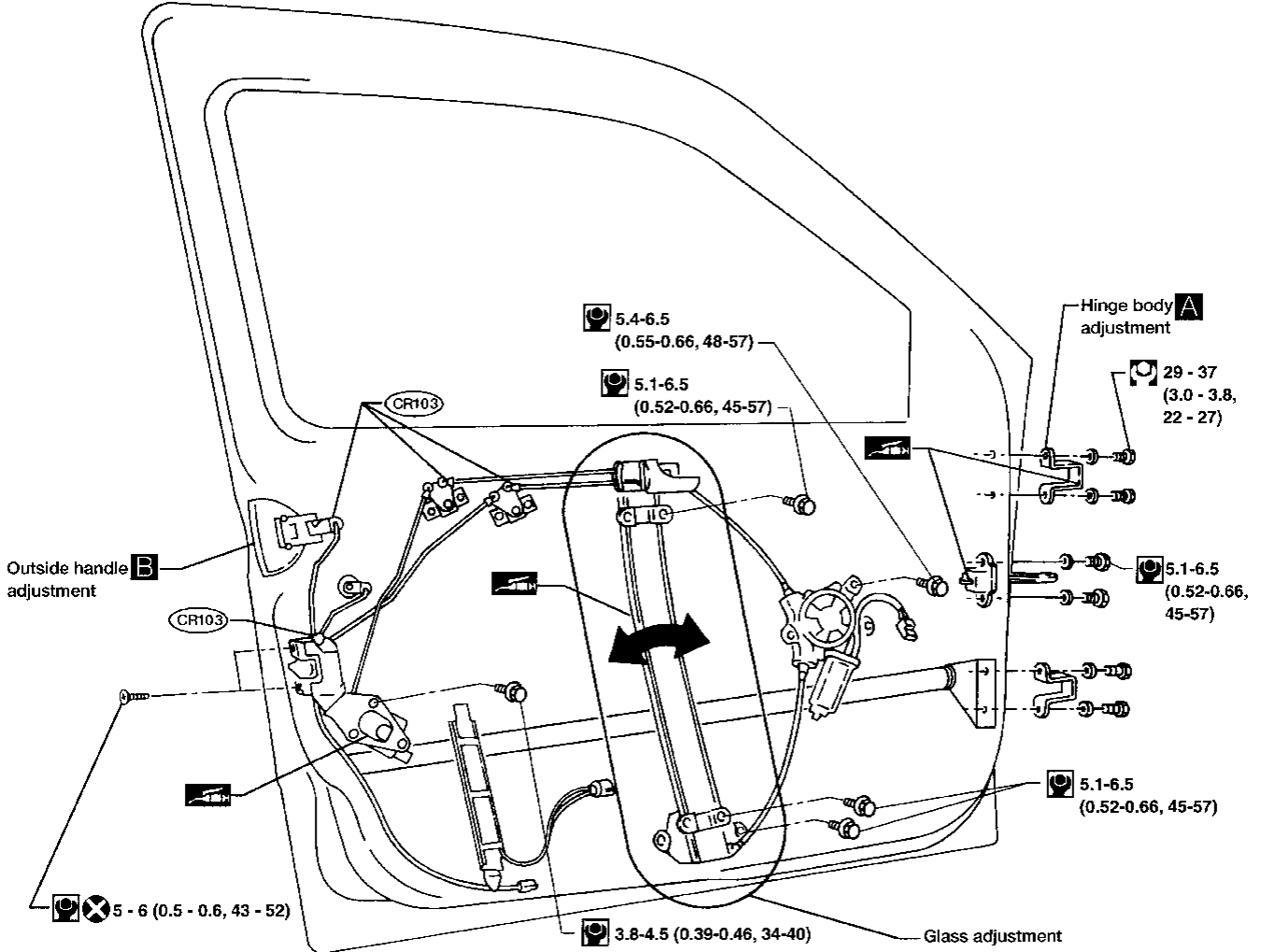

- : N·m (kg·m, in·lb)
- : N·m (kg·m, ft·lb)
- : Should be lubricated with grease
- ⊗ : Always replace after every disassembly

GI
MA
EM
LC
EC
FE
AT
FA
RA
BR
ST
RS
BT
HA
EL
IDX

DOOR

Sliding Door

SEC. 821•826•998

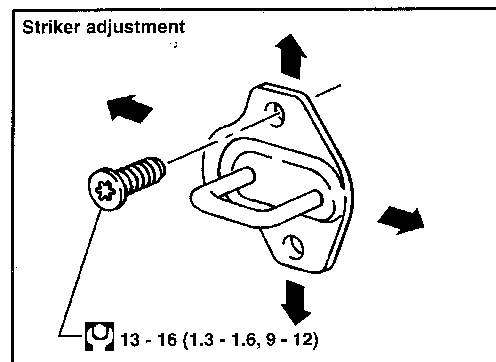
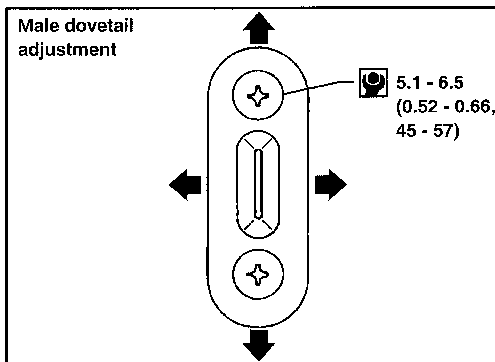
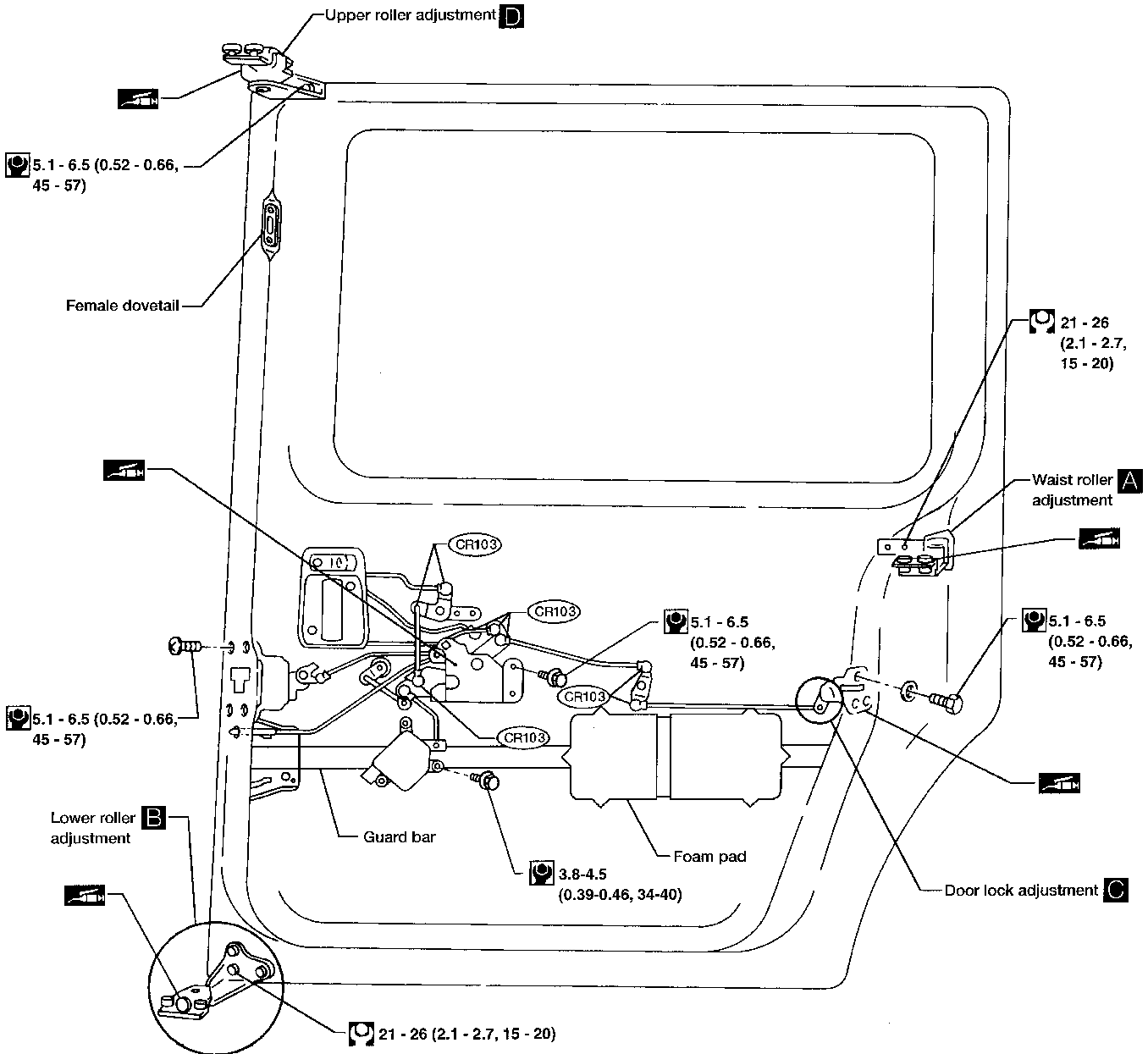

C : N·m (kg-m, in-lb)

G : N·m (kg-m, ft-lb)

A : Should be lubricated with grease

ABT212

DOOR

Sliding Door (Cont'd)

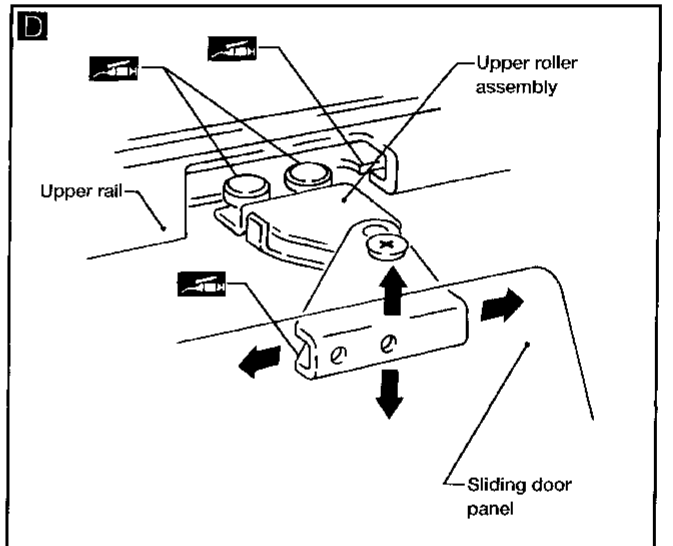
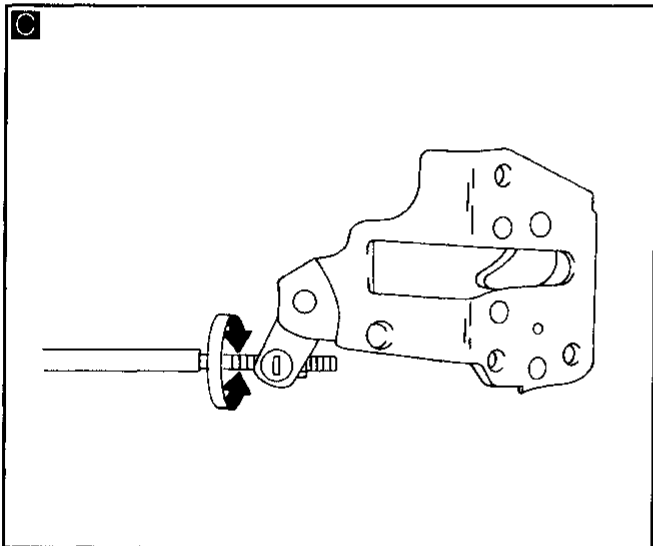
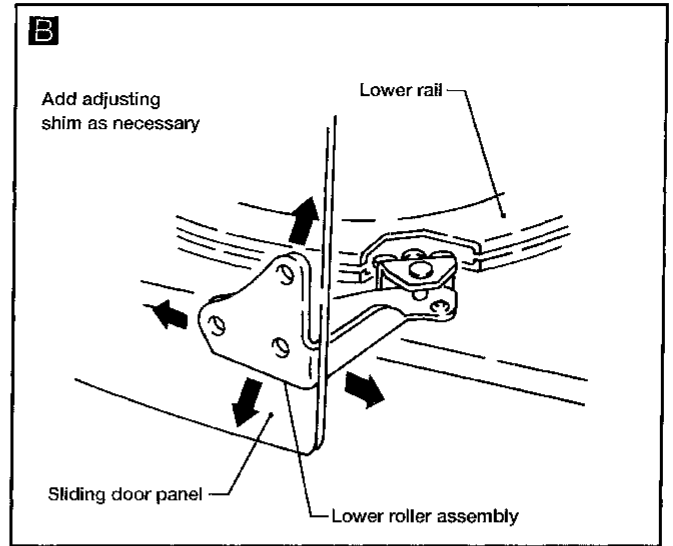
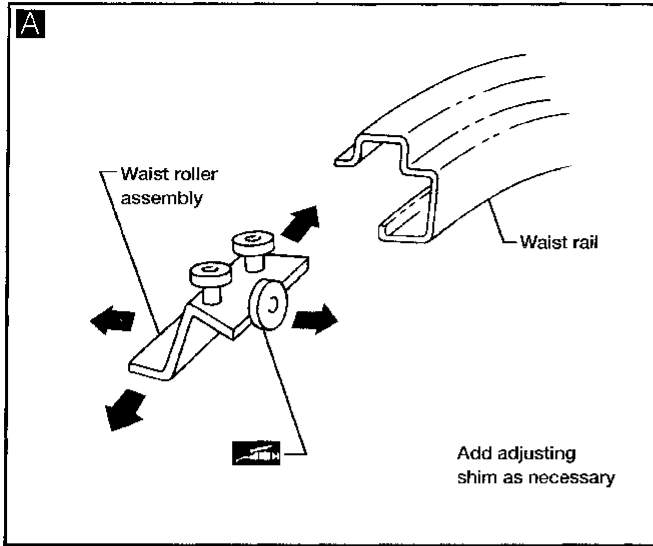

GI
MA
EM
LC
EC
FE
AT
FA
RA
BR
ST
RS
BT
HA
EL
IDX

: Should be lubricated with grease

DOOR

Rear Door

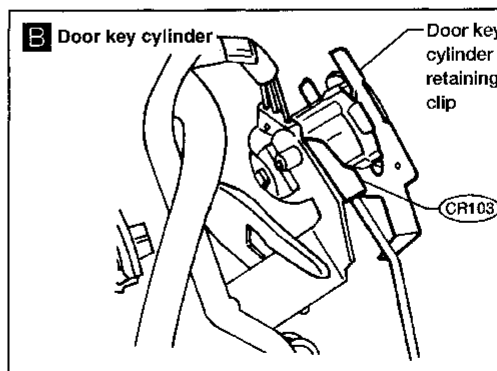
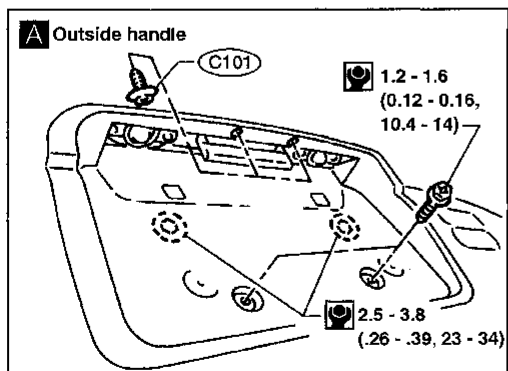
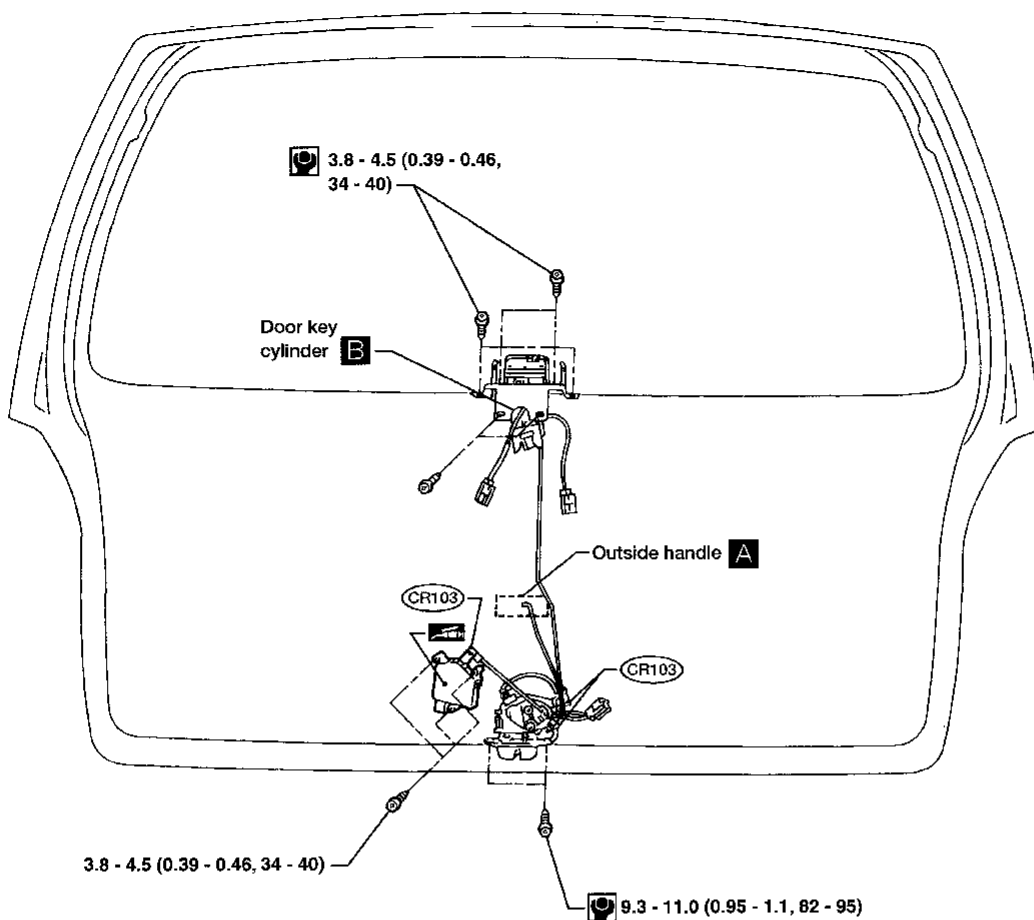

: N·m (kg·m, in·lb)

: Should be lubricated with grease

NOTES

GI

MA

EM

LC

EC

FE

AT

FA

RA

BR

ST

RS

BT

HA

EL

IDX

INSTRUMENT PANEL

CAUTION:

- Disconnect both terminals from battery in advance.
- Disconnect air bag module connectors in advance.
- Be careful not to scratch finishers and other parts.
- Never tamper with or force air bag lid open, as this may adversely affect air bag performance.

REMOVAL — Instrument panel assembly

Instrument panel assembly	Heater & A/C control	Audio control	Combination meter
Remove driver air bag module and spiral cable. Refer to RS section.			
① Center console or compact disc magazine ● Remove four clips (CS101). ● Remove four screws securing compact disc magazine.			
② Center console side finishers ● Remove two screws and disconnect foot lamp electrical connector.			
③ Cluster lid C H ● Remove four screws.			
④ Heater and air conditioner control ● Remove four screws.			
⑤ Audio ● Remove four screws securing heater and audio bracket. ● Remove four screws securing audio control to bracket.			
⑥ Ashtray and slide bracket ● Remove ashtray. ● Remove two screws securing slide bracket to instrument panel.			
⑦ Glove box I ● Remove seven screws and one clip (CS101).			
⑧ Passenger air bag module ● Refer to RS section.			
⑨ Instrument lower cover on driver side ● Remove one screw and three clips (CS101).			
⑩ Knee protector ● Remove four bolts. ● Release data link connector for GST.			
⑪ Steering column ● Disconnect shift indicator. ● Remove one screw securing air duct. ● Remove four nuts and lower steering column. ● Refer to ST section.			
⑫ Cluster lid A ● Remove four screws.			
⑬ Combination meter ● Remove four screws.			
⑭ Ventilators B C D E ● Remove side and center ventilators. ● If equipped, disconnect in-vehicle sensor electrical connector after removing center ventilator.			
⑮ Defroster grille A ● Remove front door weatherstrip. ● Remove front pillar garnish. Refer to BT-22.			
⑯ Dash lower side finisher ● Refer to BT-22.			
⑰ Mirror switch			
⑱ Instrument panel ● Remove two screws from opening for passenger air bag module. ● Remove one screw each from lower LH and RH side. ● Remove upper two bolts and one nut.			

INSTALLATION

Reverse the procedures described above.

Pay attention so as not to scratch the parts (plastic). During installation, fit the ducting parts precisely.

INSTRUMENT PANEL

SEC. 248•280•680•685

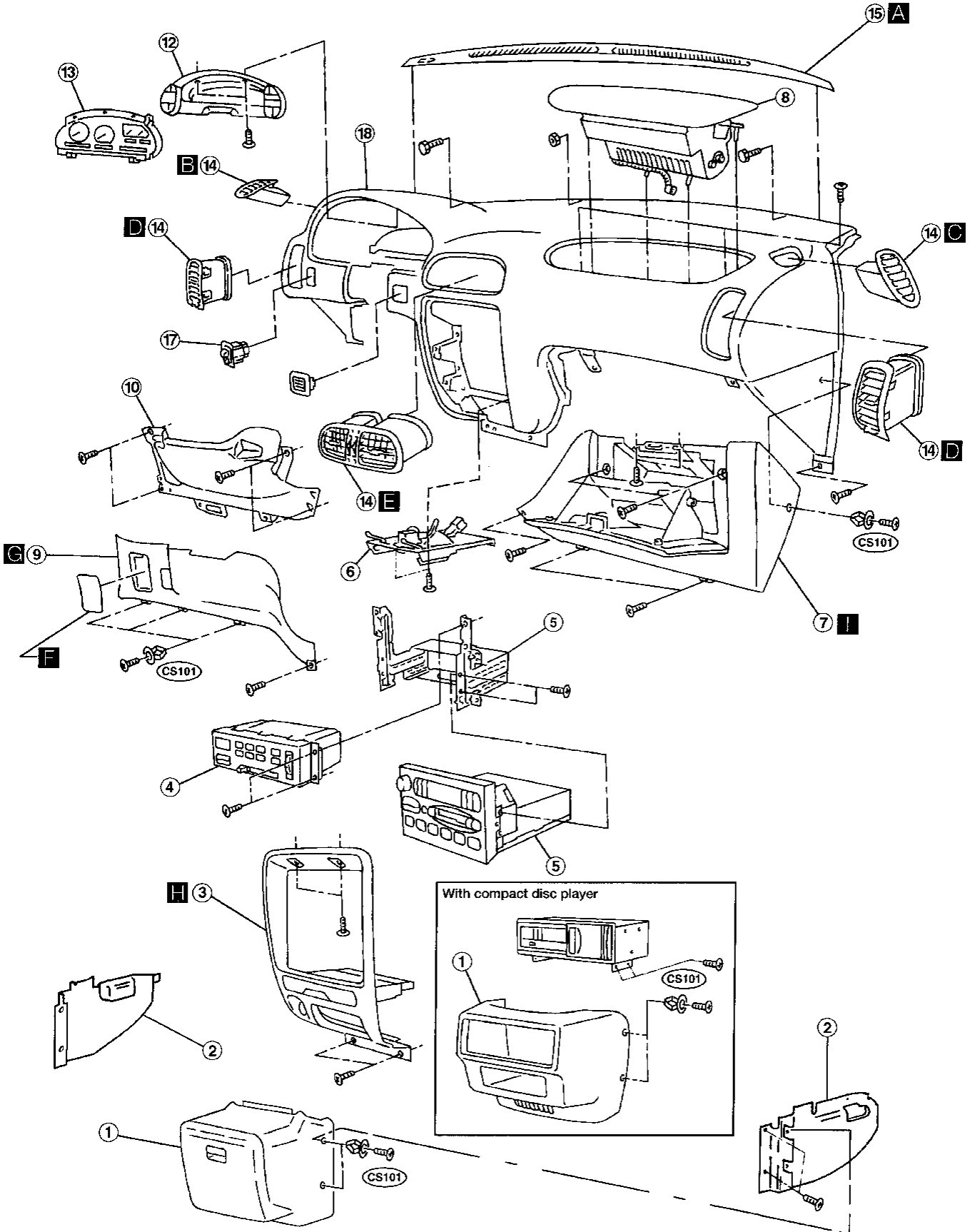

GI
MA
EM
LC
EC
FE
AT
FA
RA
BR
ST
RS
BT
HA
EL
IDX

INSTRUMENT PANEL

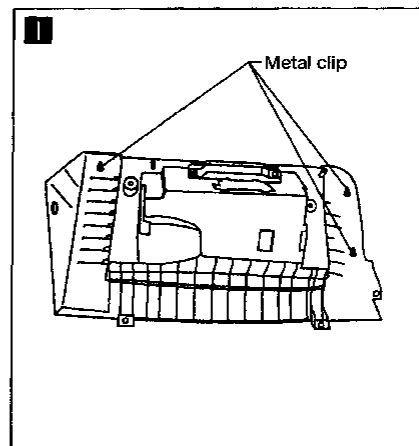
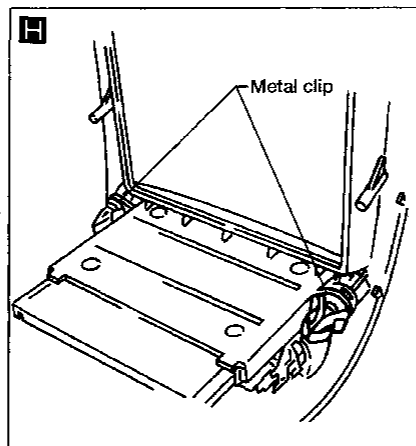
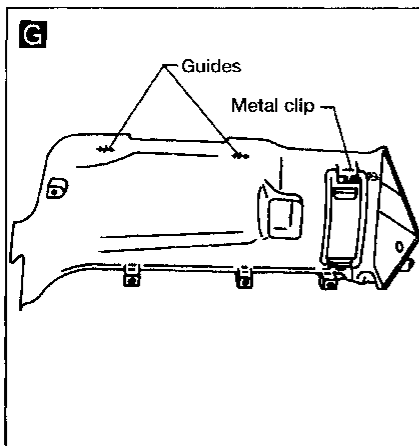
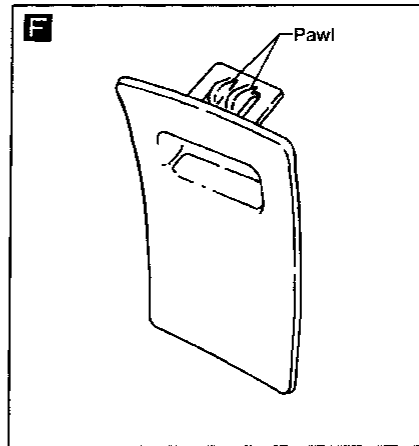
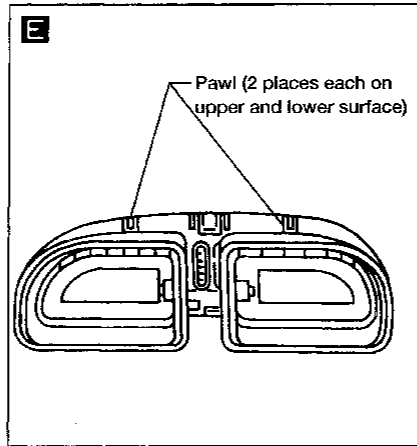
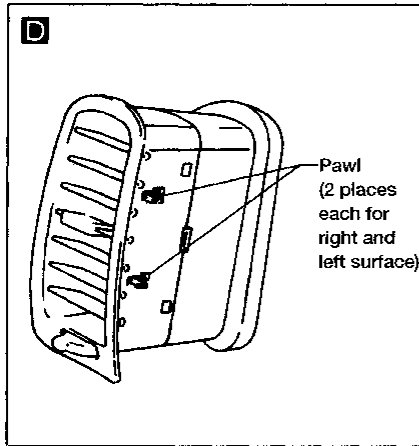
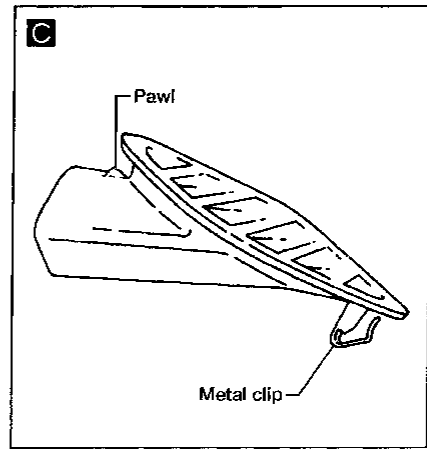
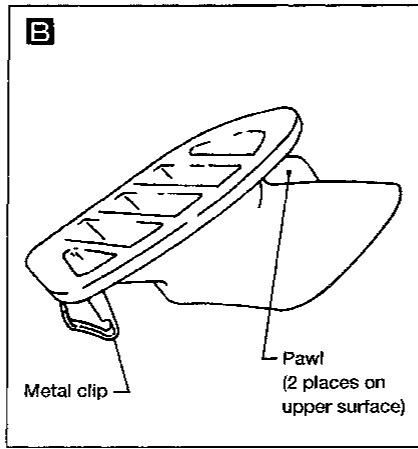
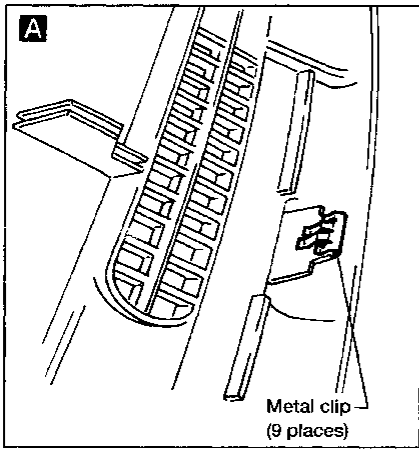

INSTRUMENT PANEL

NOTES

GI

MA

EM

LC

EC

FE

AT

FA

RA

BR

ST

RS

BT

HA

EL

IDX

INTERIOR TRIM

- Wrap the tip of flat-bladed screwdriver with a cloth when removing metal clips from garnish.
- When handling interior or exterior parts, do not use excessive force and take care not to damage them.

Side and Floor Trim

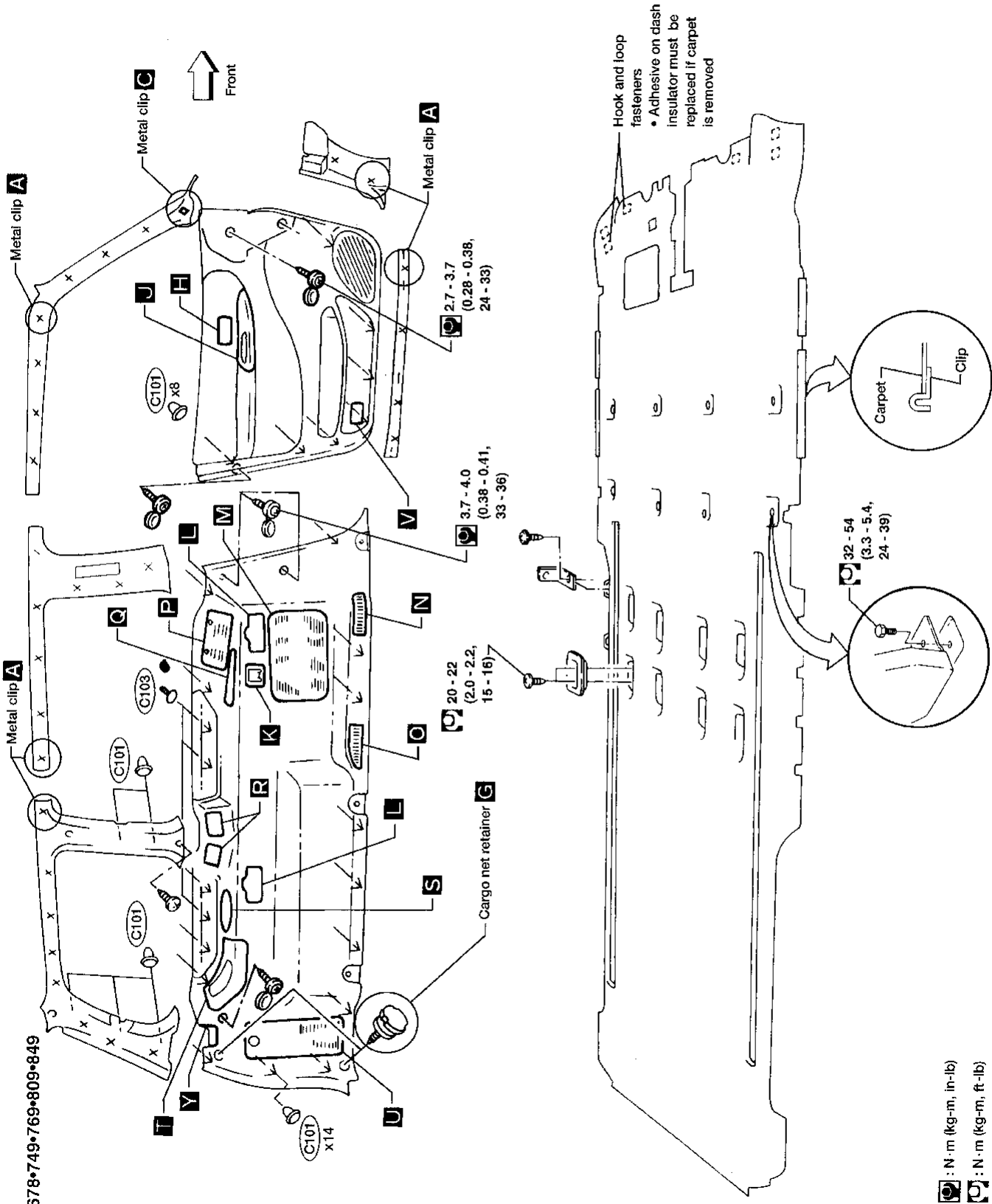

SEC. 678•749•769•809•849

● : N·m (kg-m, in-lb)
 ◻ : N·m (kg-m, ft-lb)

ABT114

INTERIOR TRIM

Side and Floor Trim (Cont'd)

SEC. 267•769•828•849•909

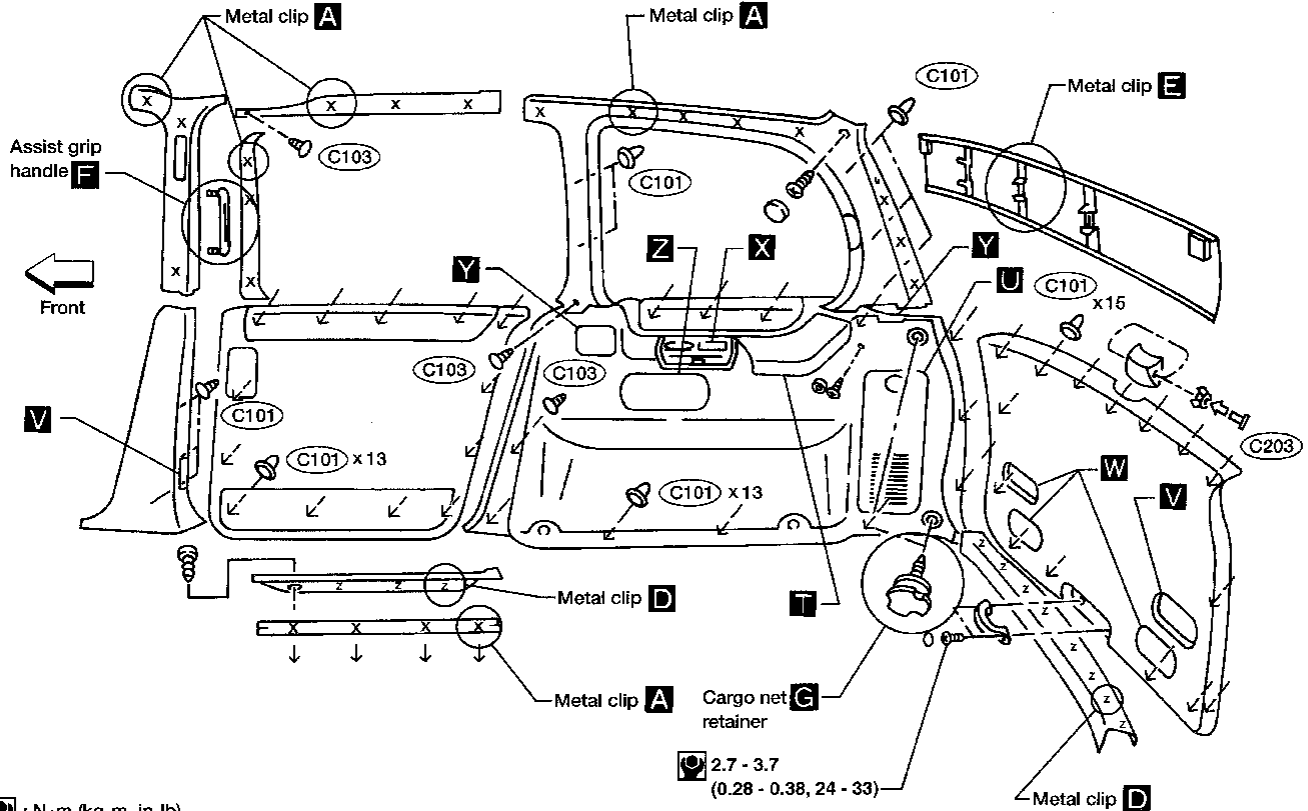

⊙ : N·m (kg-m, in-lb)
 ⊙ : N·m (kg-m, ft-lb)

⊙ 2.7 - 3.7
 (0.28 - 0.38, 24 - 33)

ABT113

GI
 MA
 EM
 LC
 EC
 FE
 AT
 FA
 RA
 BR
 ST
 RS
BT
 HA
 EL
 IDX

INTERIOR TRIM

Side and Floor Trim (Cont'd)

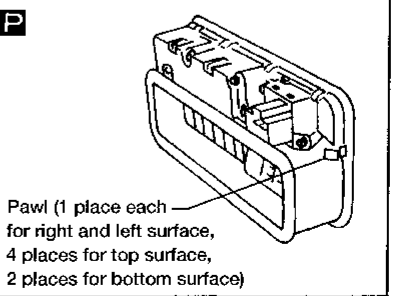
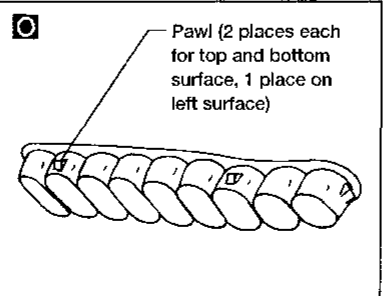
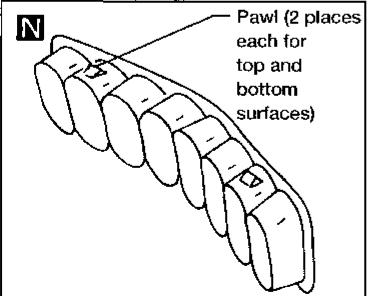
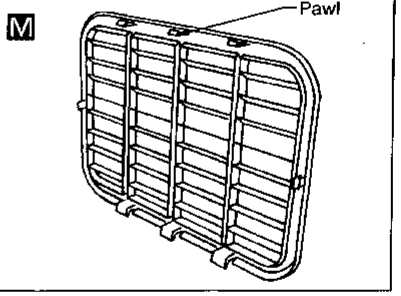
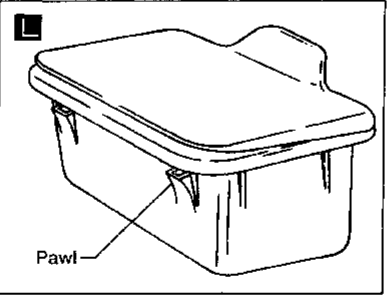
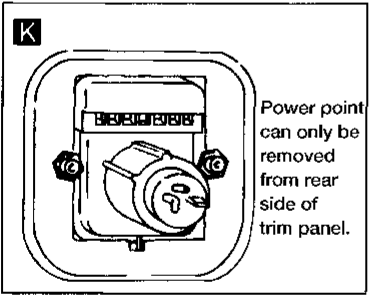
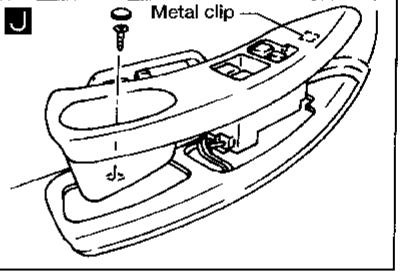
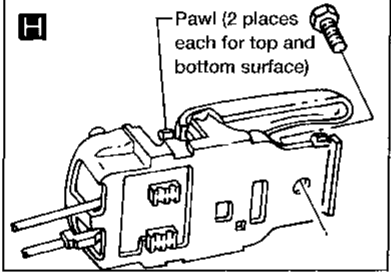
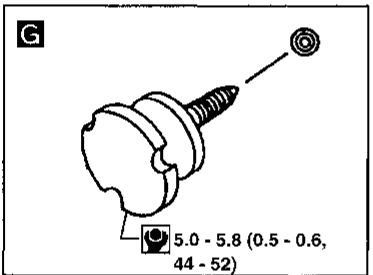
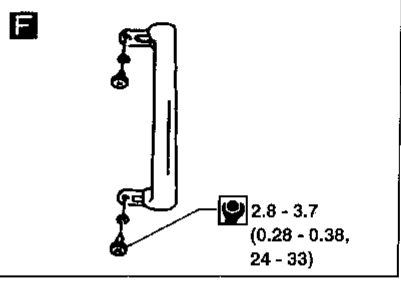
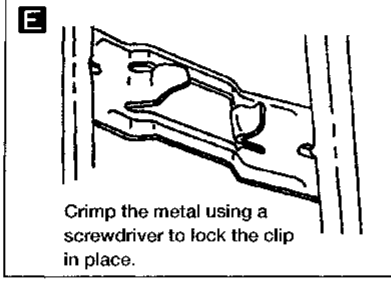
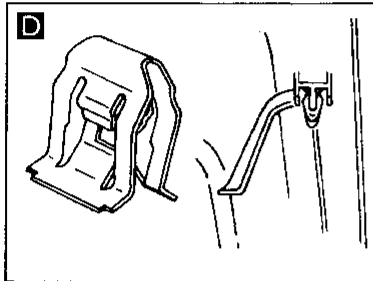
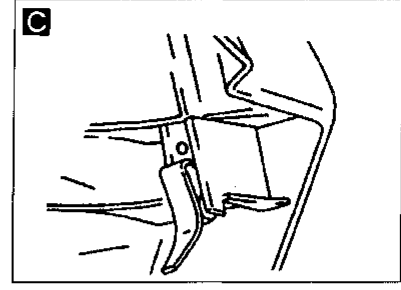
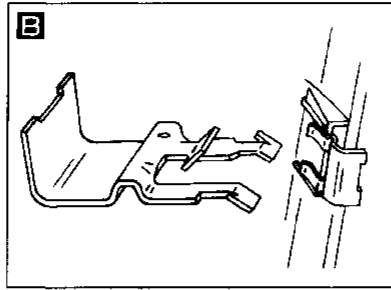
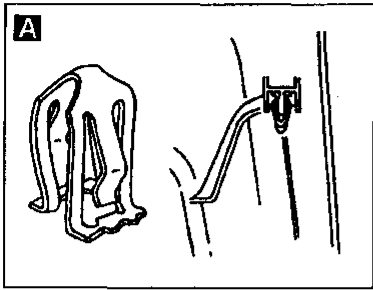

INTERIOR TRIM

Side and Floor Trim (Cont'd)

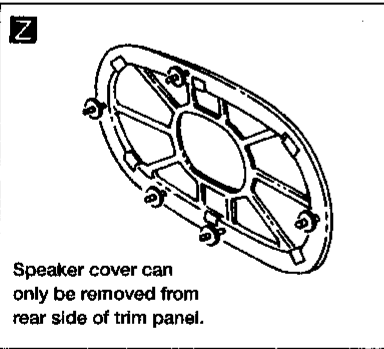
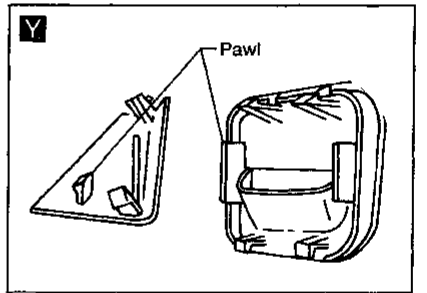
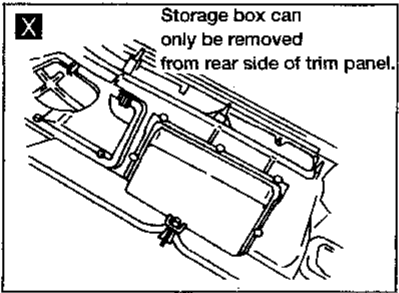
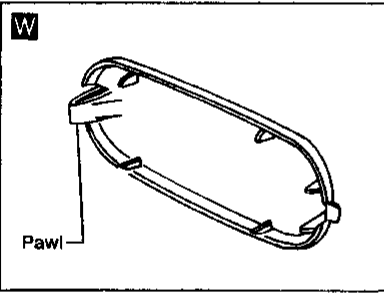
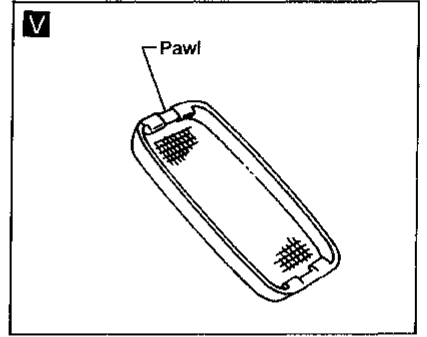
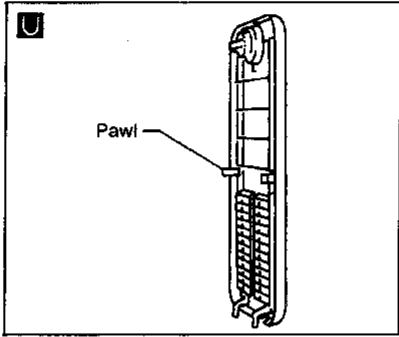
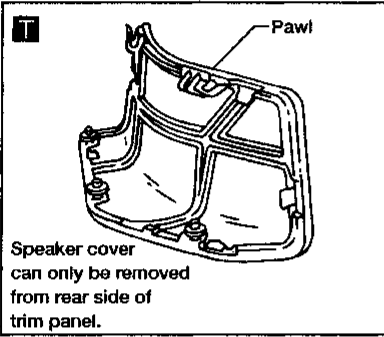
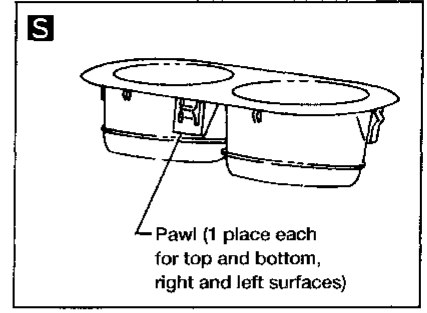
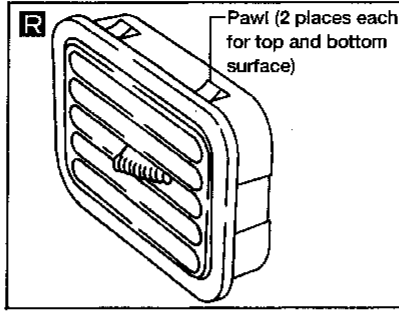
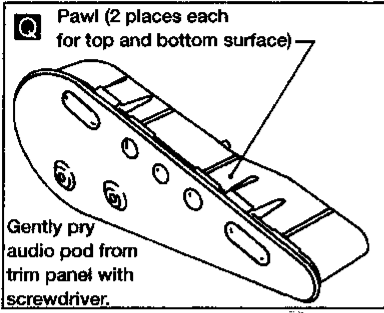

GI
MA
EM
LC
EC
FE
AT
FA
RA
BR
ST
RS
BT
HA
EL
IDX

INTERIOR TRIM

Roof Trim

With sun roof

SEC. 264•738•964

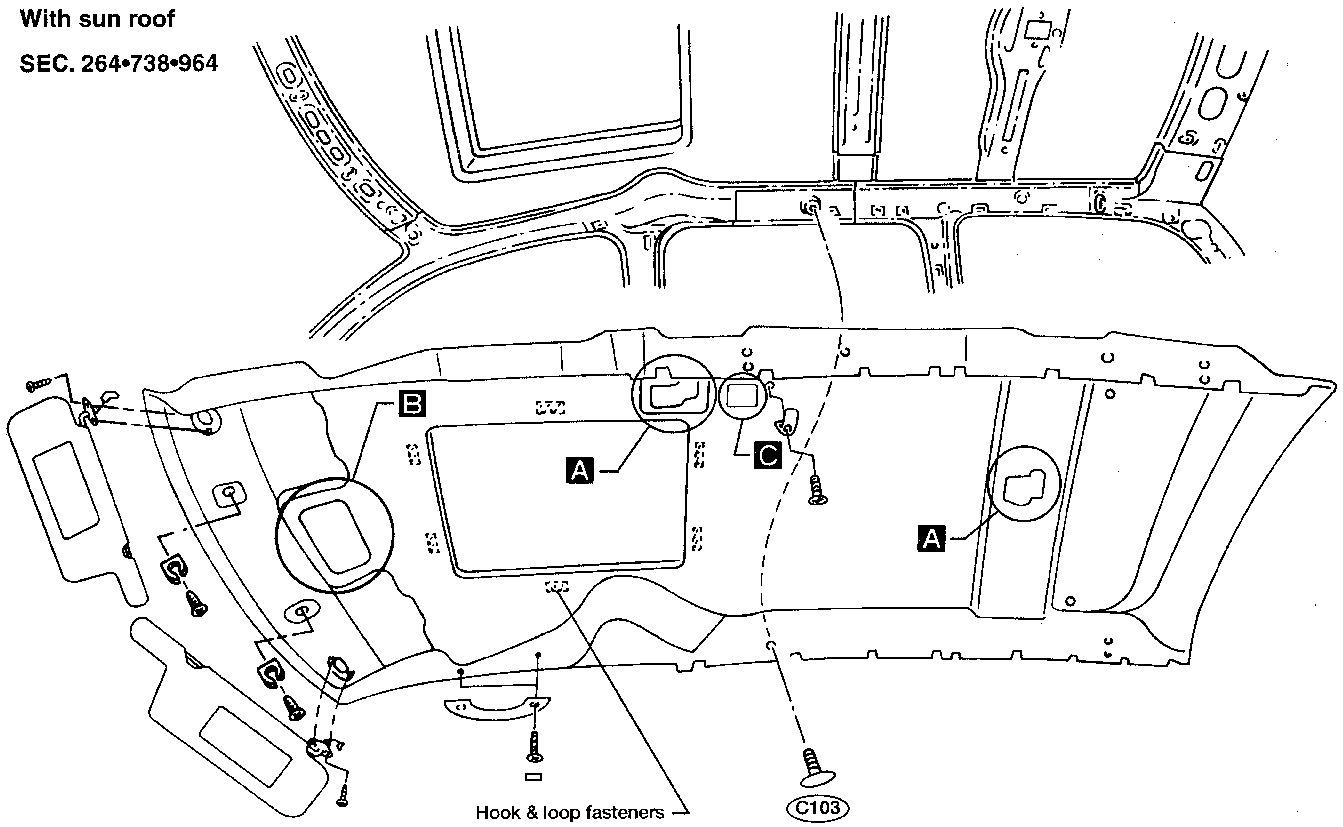

Without sun roof

SEC. 264•738•964

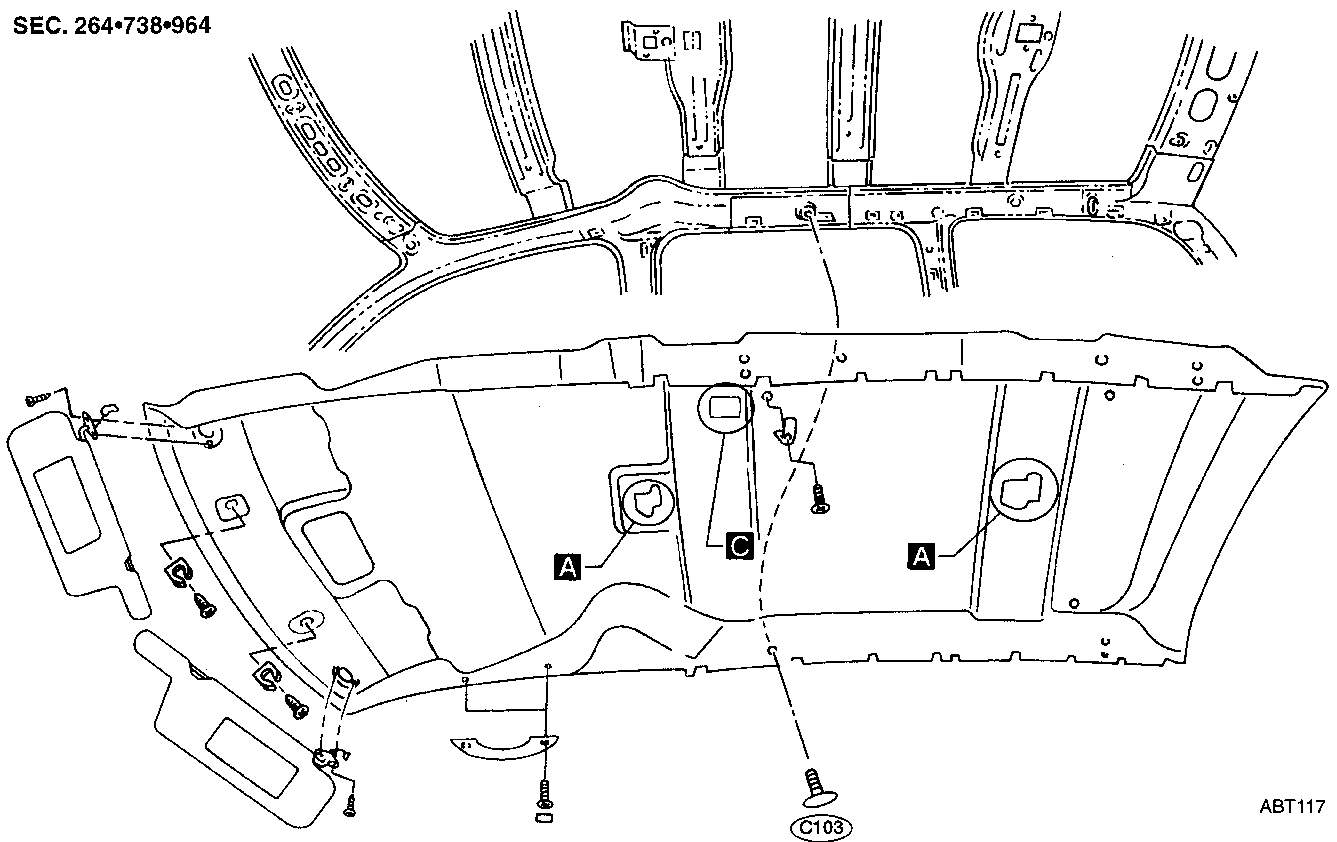

BT-26

ABT117

INTERIOR TRIM

Roof Trim (Cont'd)

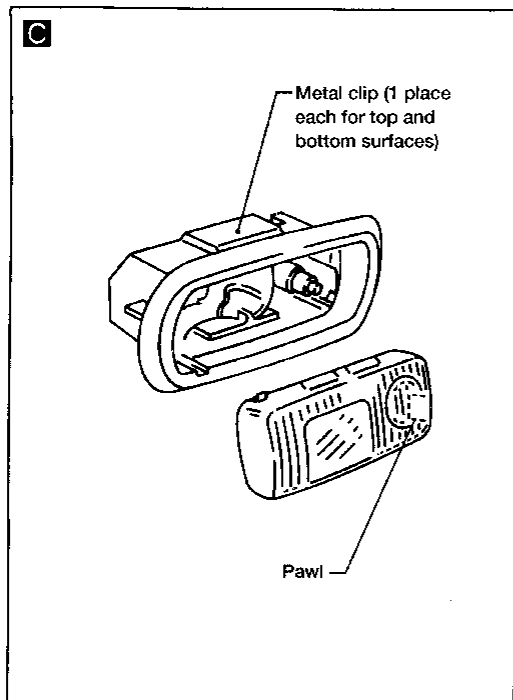
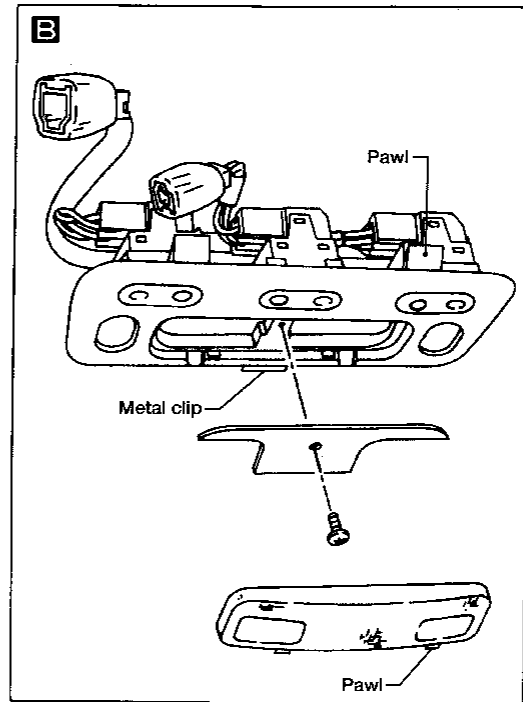
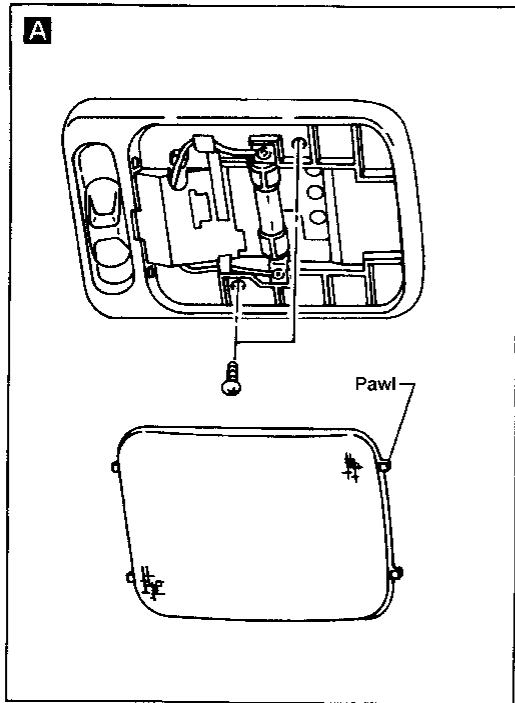

GI
MA
EM
LC
EC
FE
AT
FA
RA
BR
ST
RS
BT
HA
EL
IDX

EXTERIOR

- Apply sealing compound where necessary while installing parts.
- When applying sealing compound, be careful that the sealing compound does not protrude from parts.

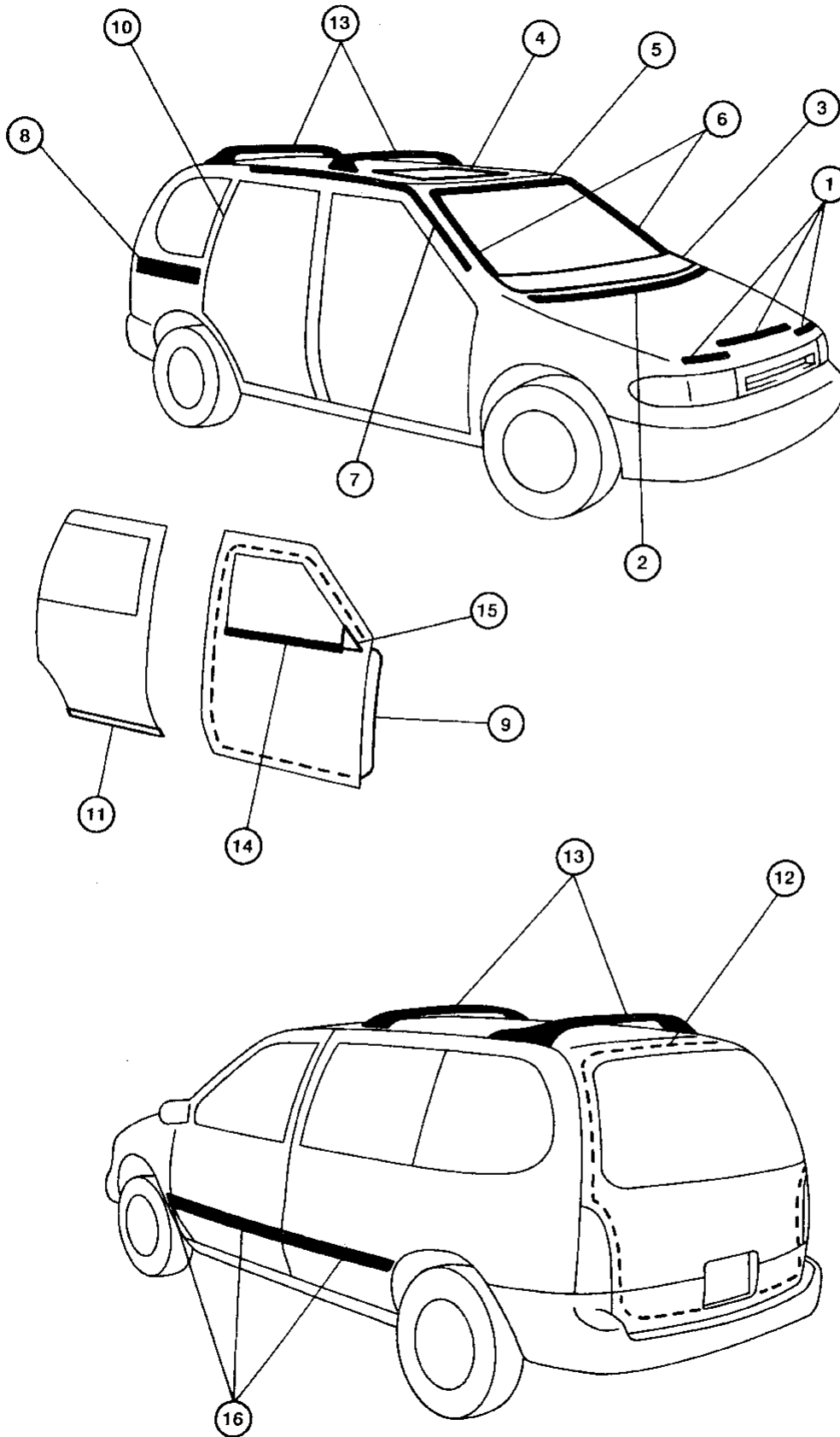

① Hood front sealing rubber

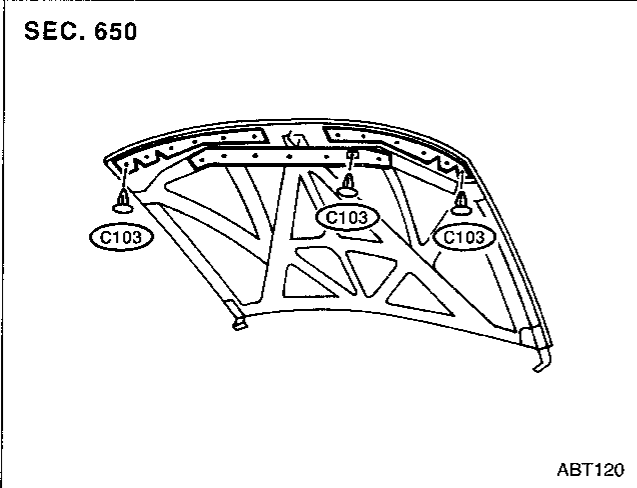

② ③ Hood rear sealing rubber and cowl top grille

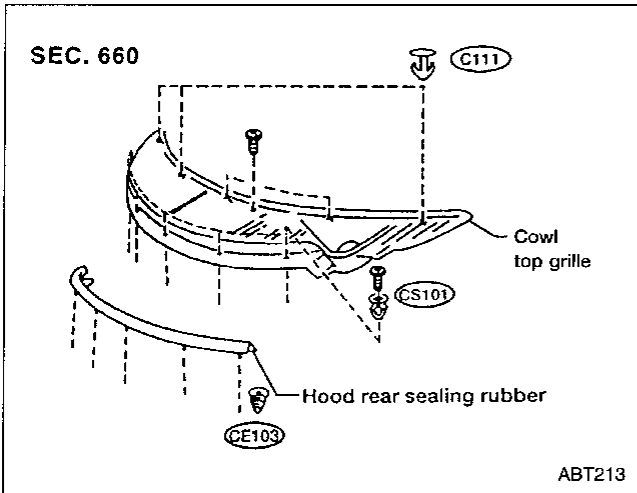

④ Sun roof frame weatherstrip and sun roof lid weatherstrip

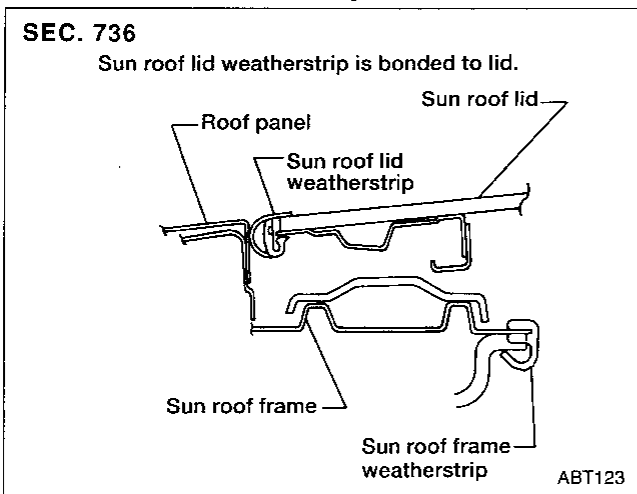

⑤ Windshield upper molding

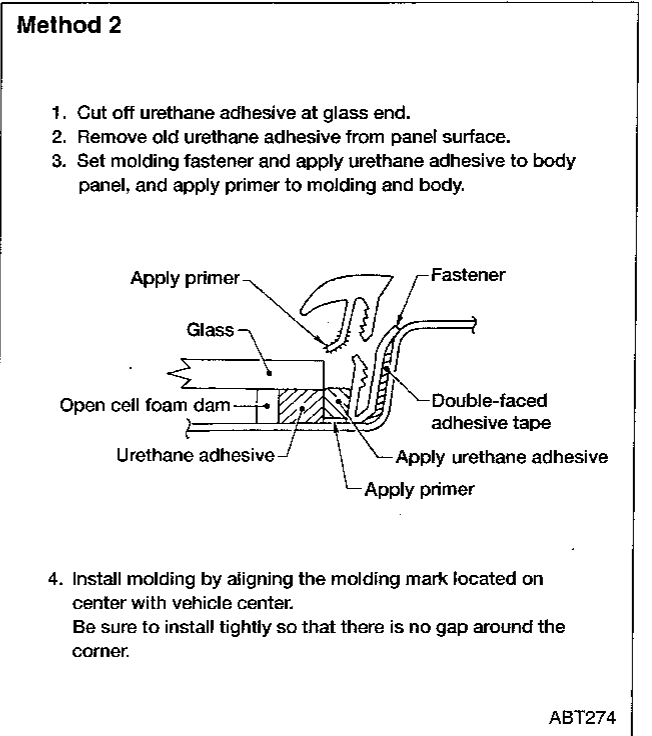
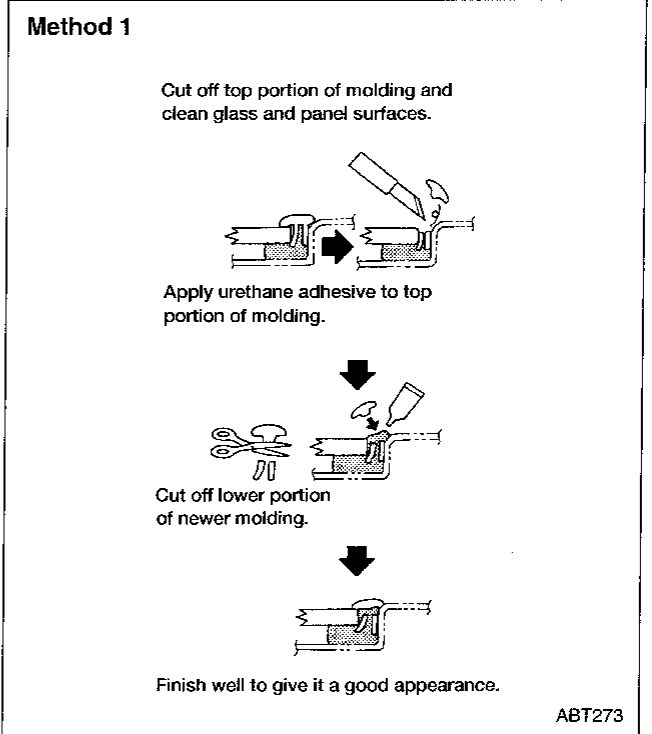

⑥ Windshield side molding

It is mounted with screws.

GI
MA
EM
LC
EC
FE
AT
FA
RA
BR
ST
RS
BT
HA
EL
IDX

⑦ Body side drip molding

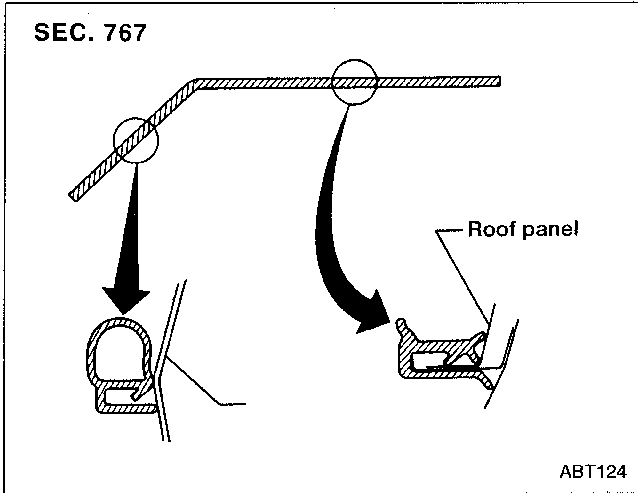

⑩ Sliding door weatherstrip

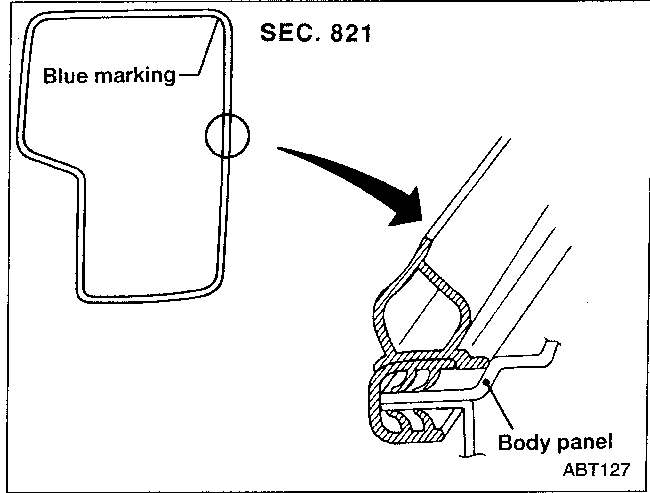

⑧ Waist rail finisher

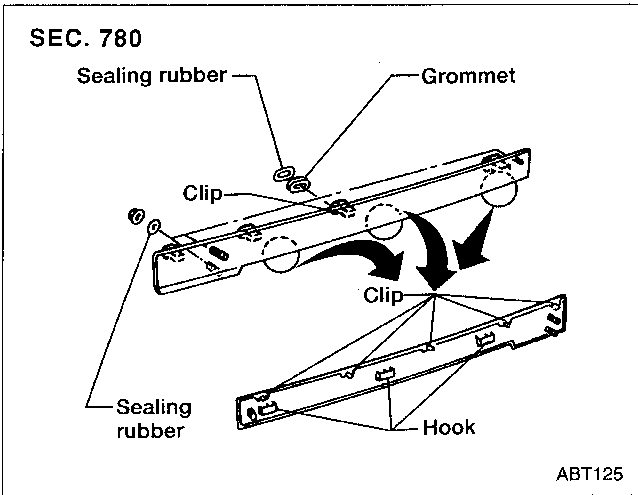

⑪ Sliding door lower seal

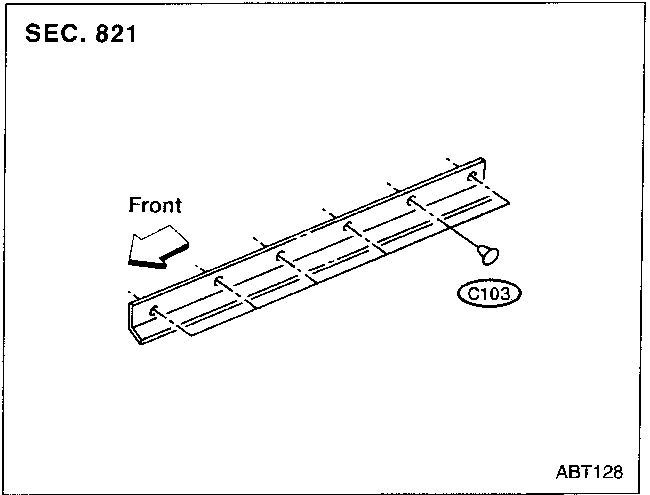

⑨ Front door weatherstrip

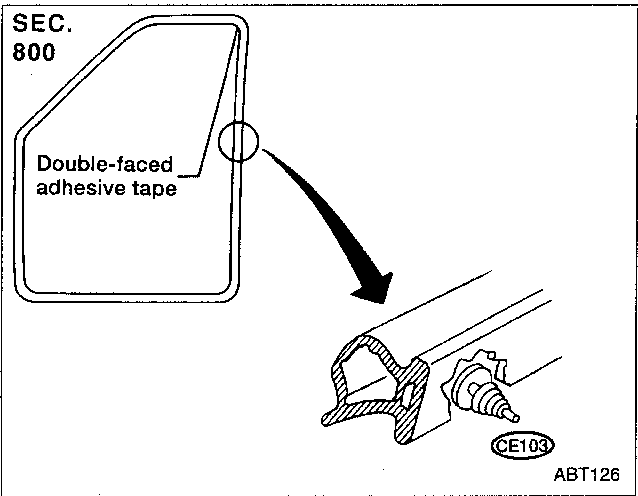

⑫ Back door opening weatherstrip

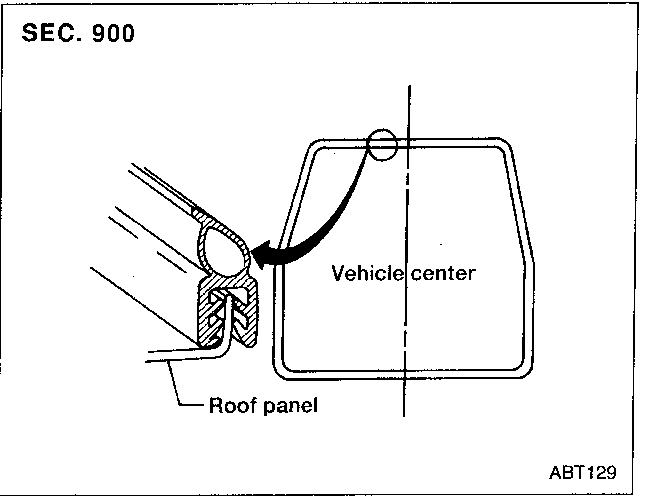

13 Luggage rack

SEC. 730
With sun roof

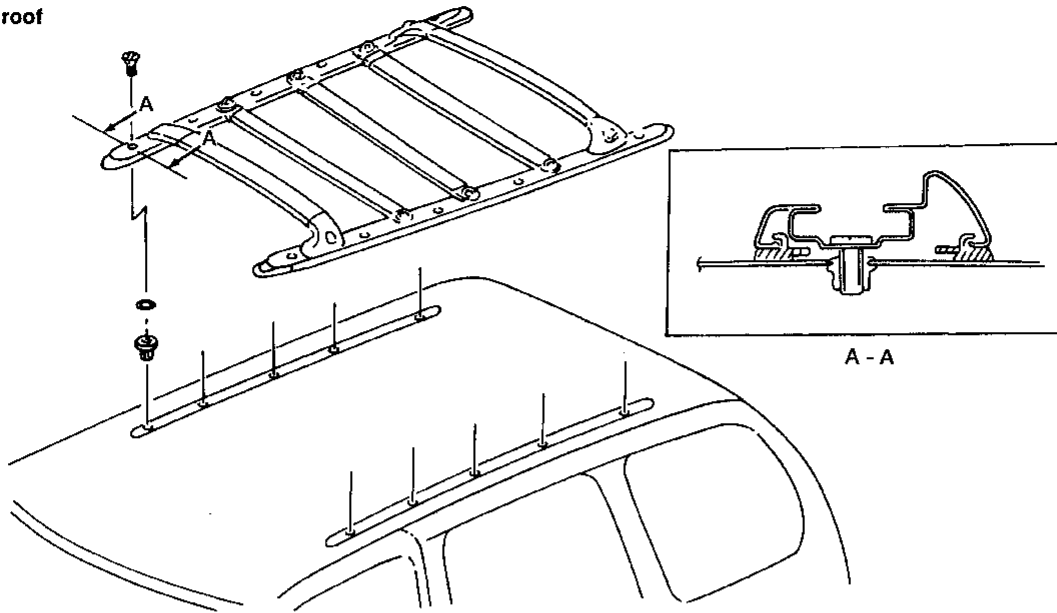

Without sun roof

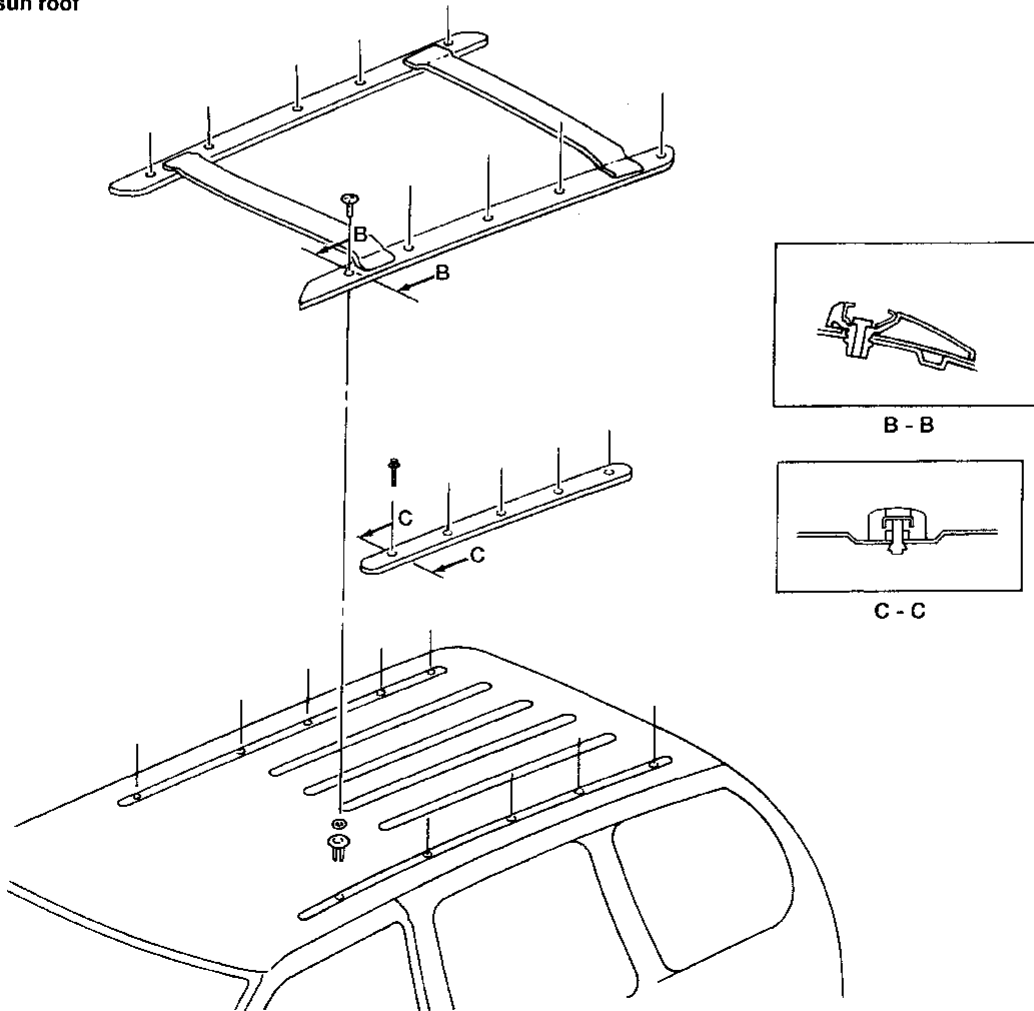

GI
MA
EM
LC
EC
FE
AT
FA
RA
BR
ST
RS
BT
HA
EL
IDX

14 Outside door molding

SEC. 800

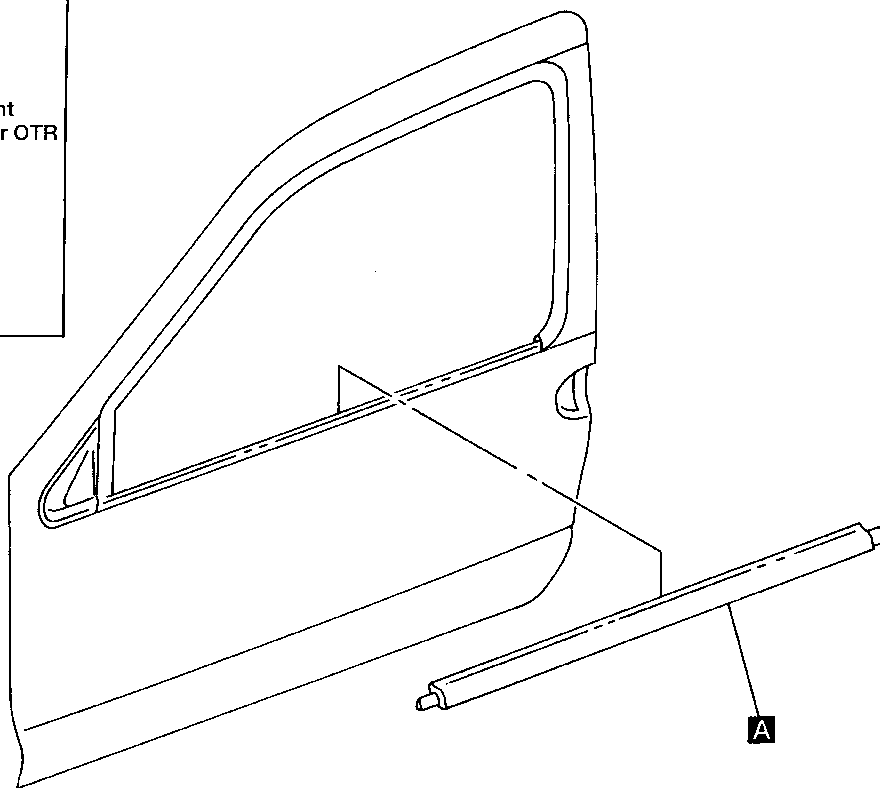
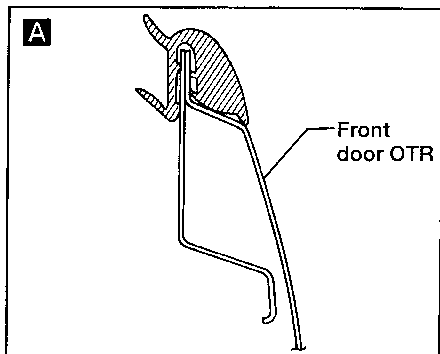

ABT130

15 Front door corner covers

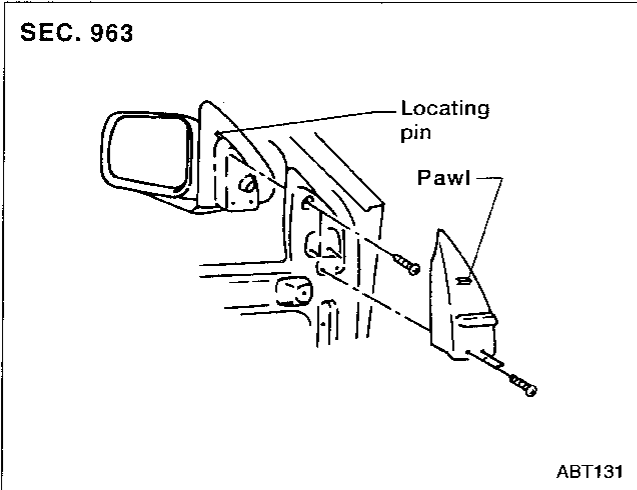

GI
MA
EM
LC
EC
FE
AT
FA
RA
BR
ST
RS
BT
HA
EL
IDX

16 Side guard molding

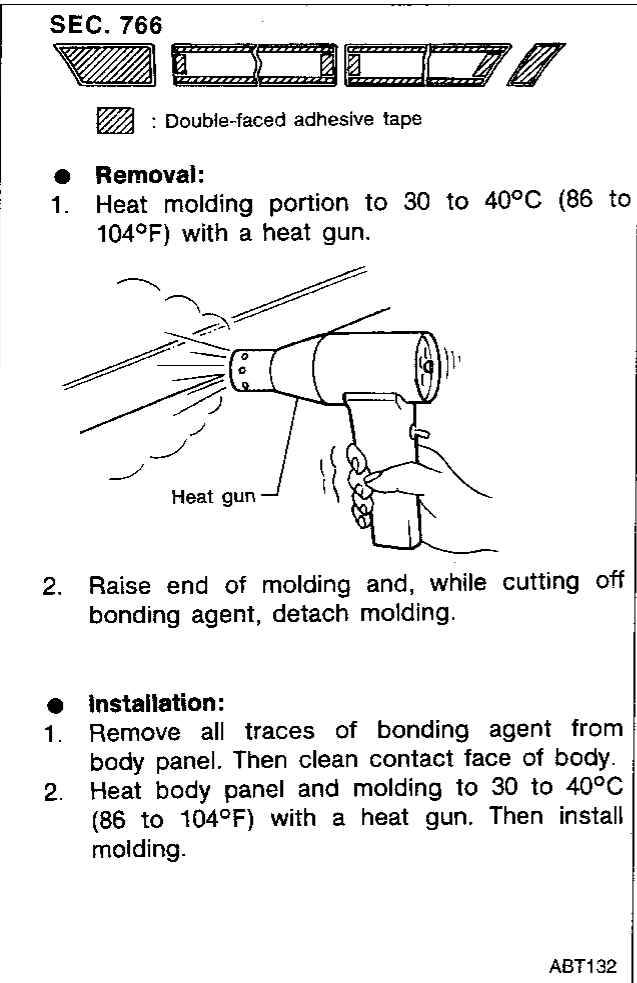

SEAT

- When removing or installing the seat trim, handle it carefully to keep it clean and undamaged.

Front Seat

SEC. 870

Installation sequence

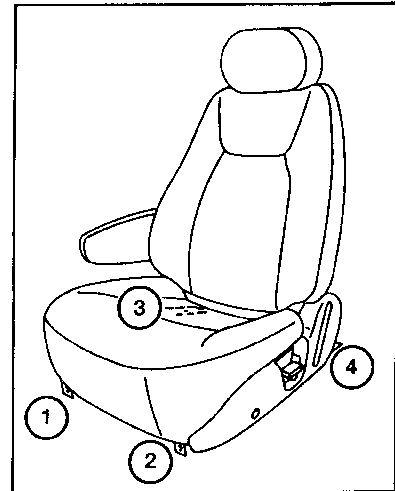

Head rest holder
 • Roll up seat back trim and pinch bottom.

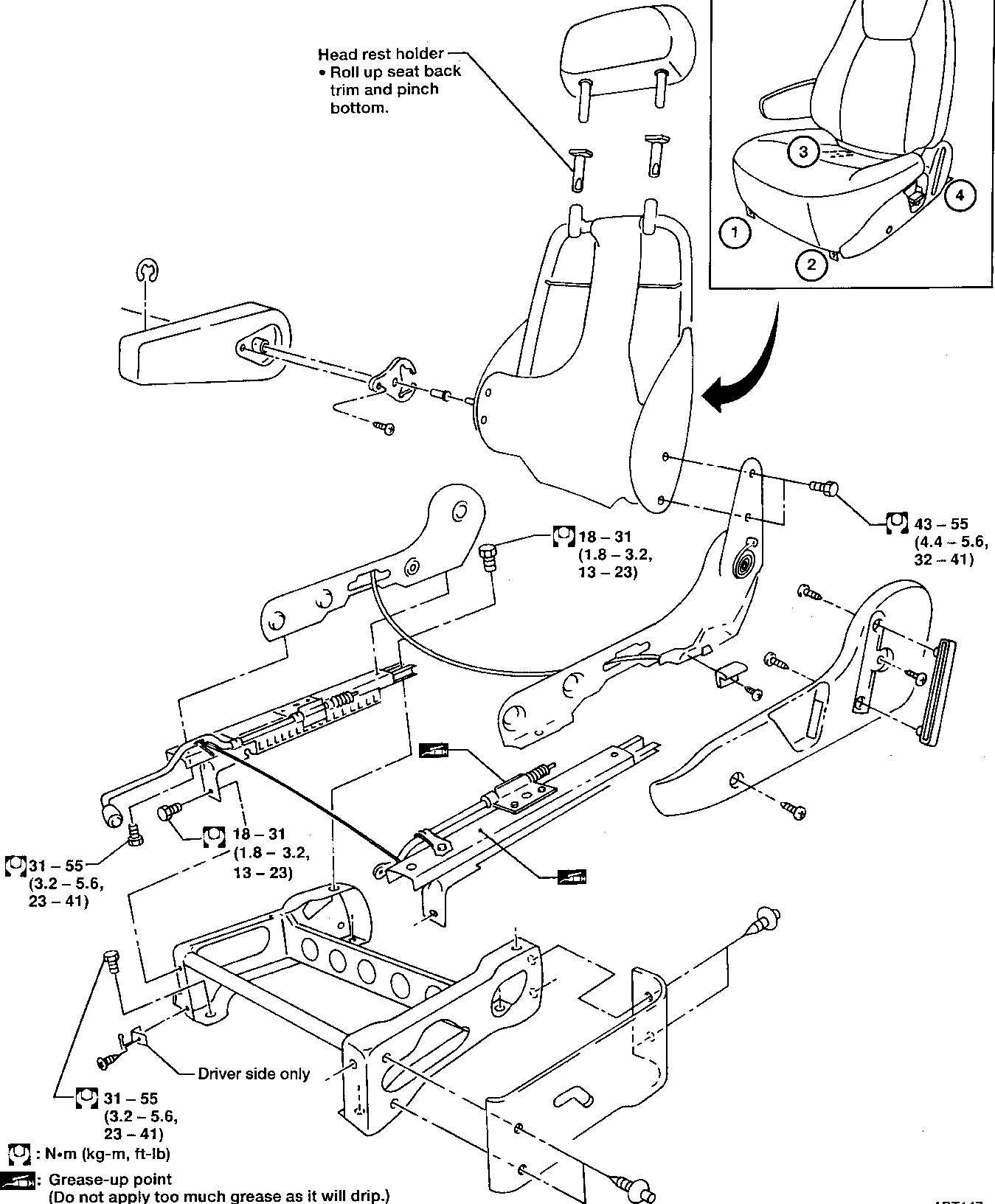

ABT147

BT-34

SEAT

Front Power Seat

SEC. 870

Installation sequence

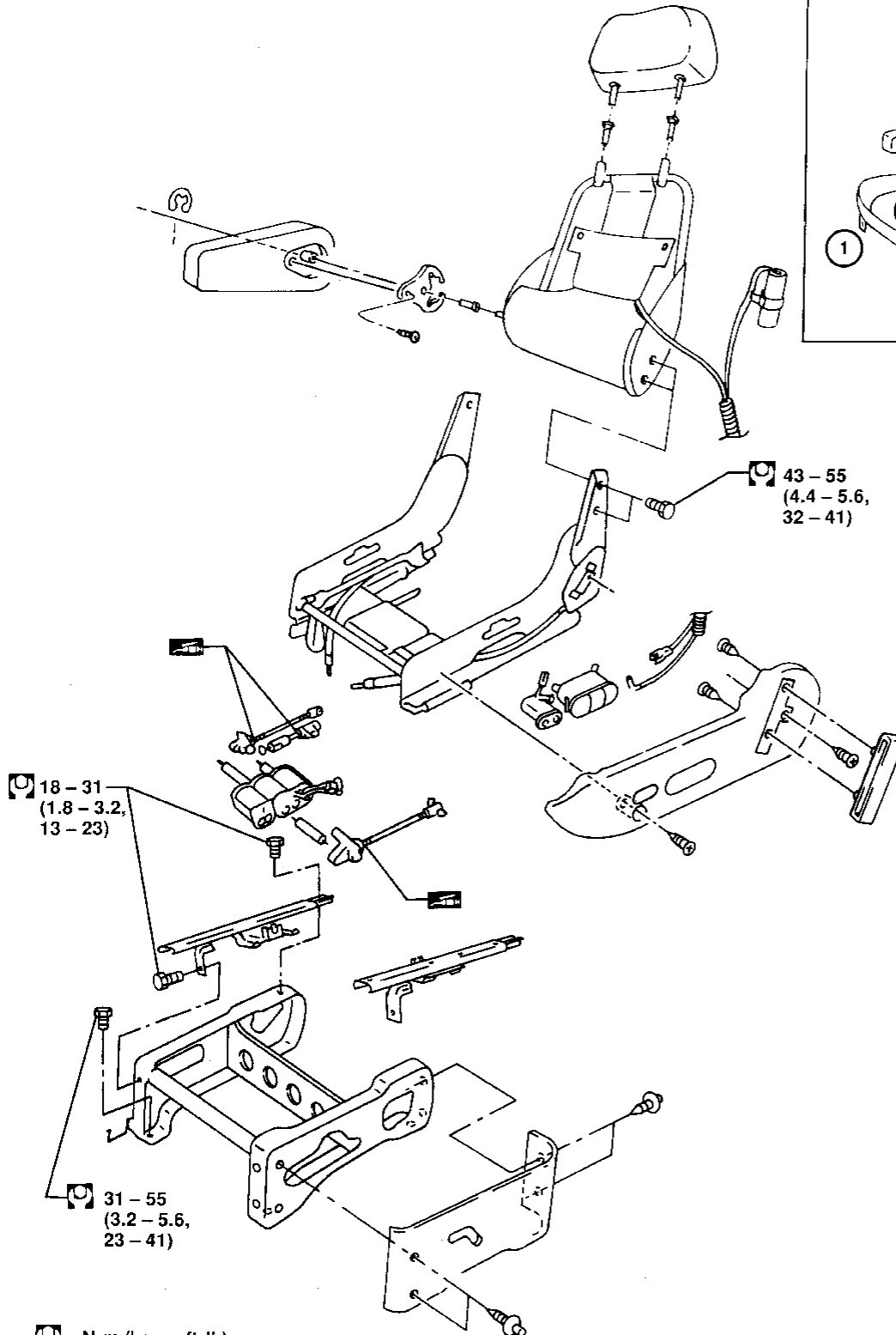
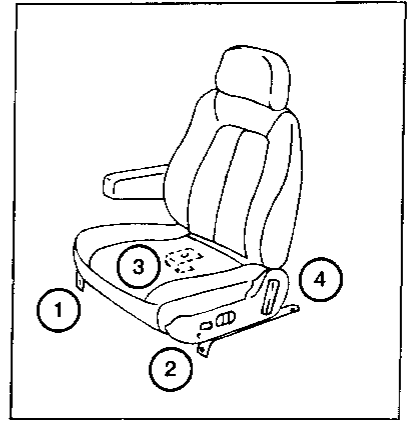

 : N·m (kg-m, ft-lb)

 : Grease-up point
(Do not apply too much grease as it will drip.)

GI

MA

EM

LC

EC

FE

AT

FA

RA

BR

ST

RS

BT

HA

EL

IDX

SEAT

2nd Seat

TYPE I

SEC. 880C

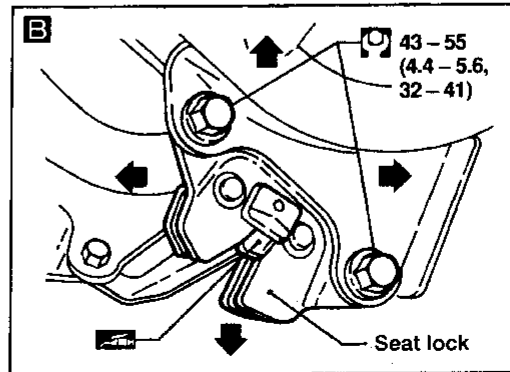
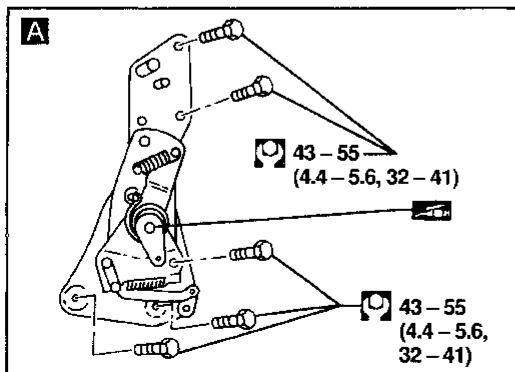
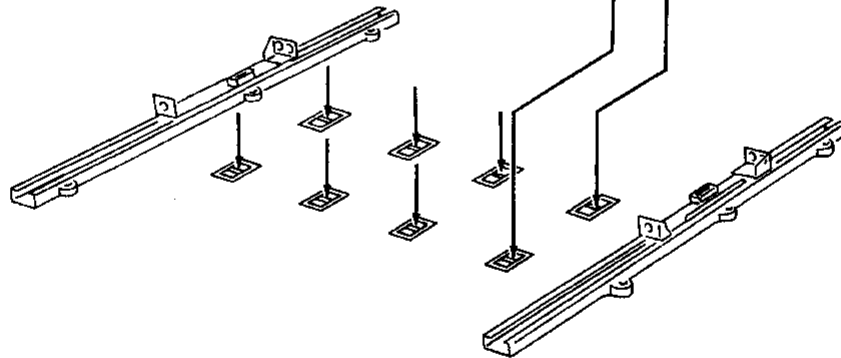
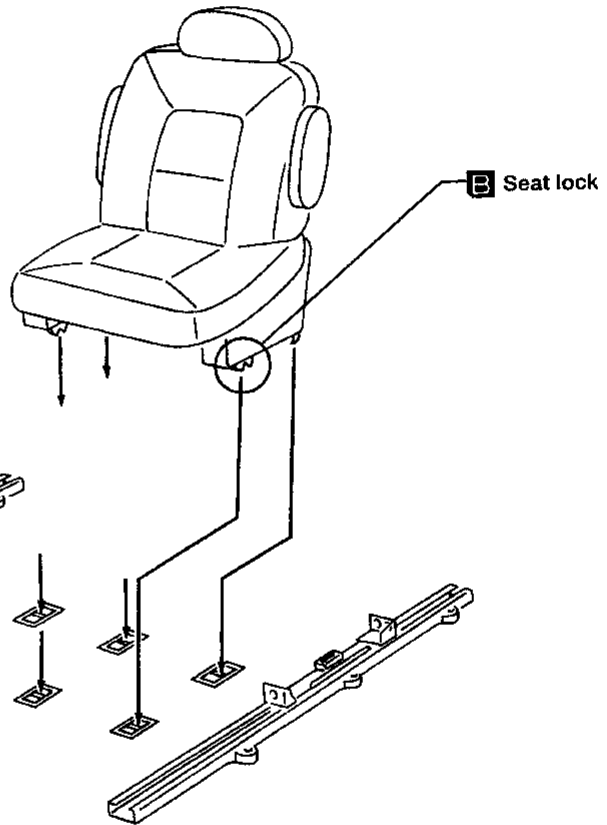
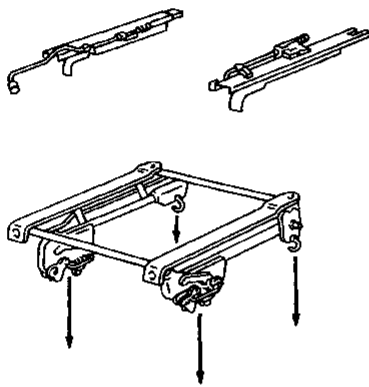
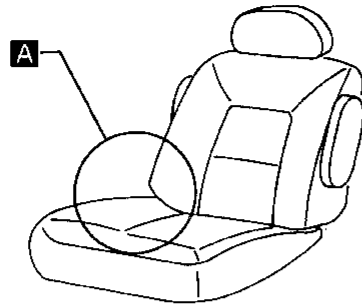

: N•m (kg-m, ft-lb)

: Lubricate with grease

SEAT

2nd Seat (Cont'd)

- For Built-In Child Seat, refer to RS section.

TYPE II

SEC. 880B

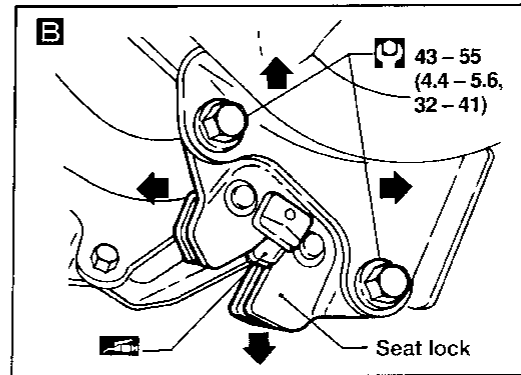
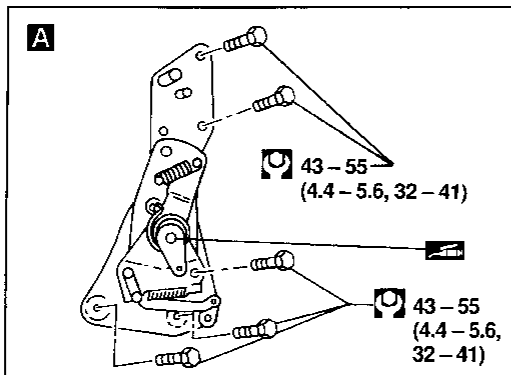
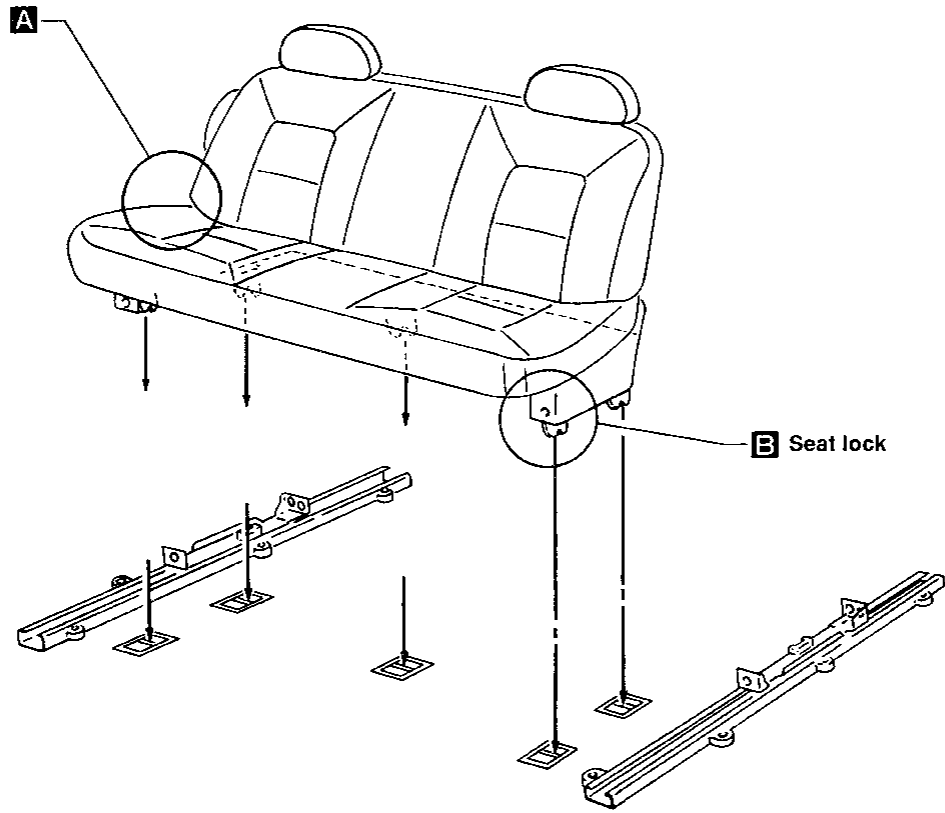

: N•m (kg-m, ft-lb)

: Lubricate with grease

GI

MA

EM

LC

EC

FE

AT

FA

RA

BR

ST

RS

BT

HA

EL

IDX

3rd Seat

3RD SLIDING SEAT RAILS — Installation

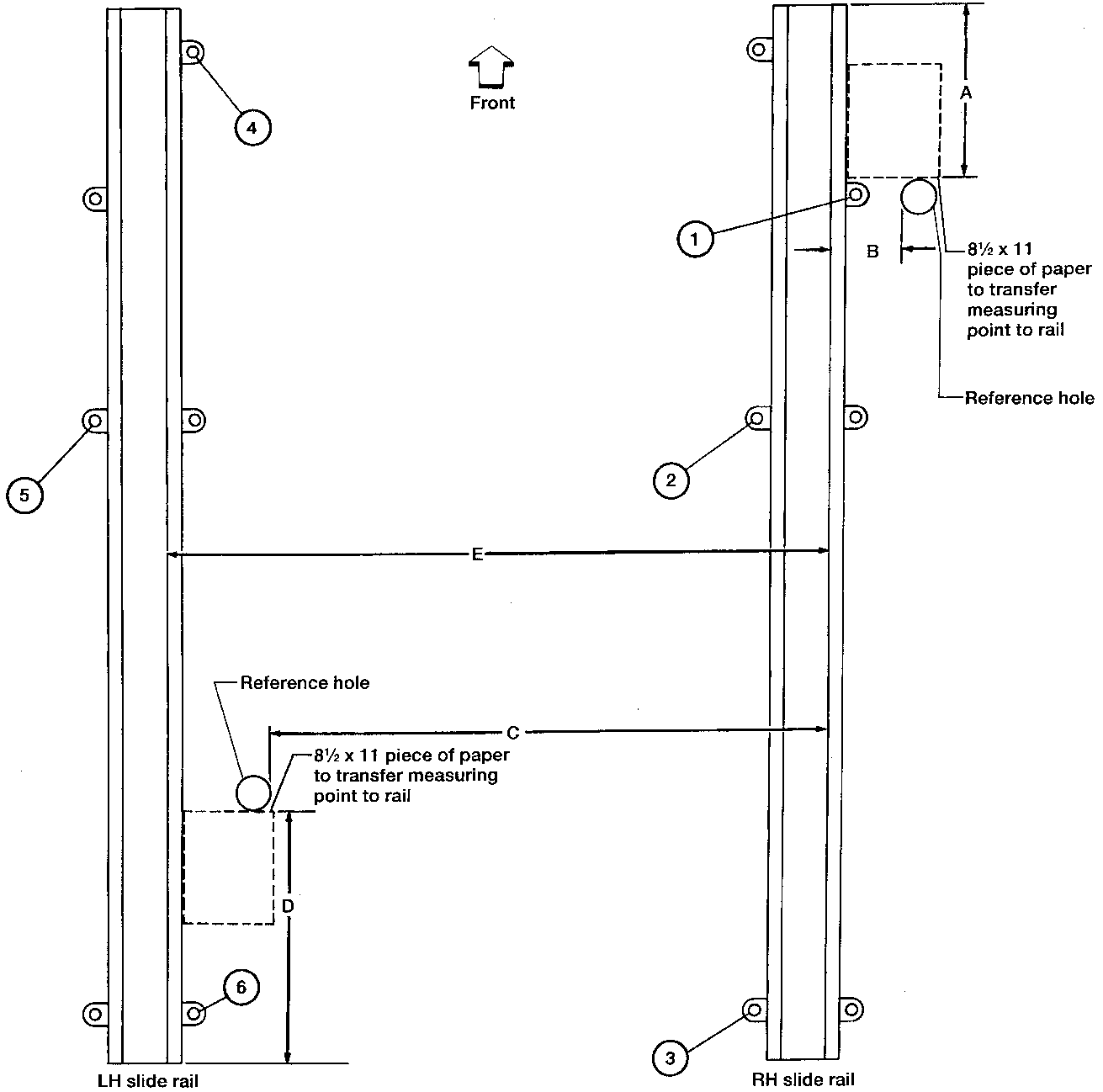

SEAT

3rd Seat (Cont'd) THIRD SLIDING SEAT RAILS

Installation for new rails

- The following dimensions may vary by 0.5 mm (0.020 in) to obtain minimum effort to slide the 3rd seat.
 - Use an 8½x11 inch piece of paper to determine distance from reference hole to edge of slide rail.
1. Position the RH slide assembly in the vehicle with the roller in 2nd seating position and loosely install bolts ①, ② and ③.
 2. Measure distance "A".
Distance "A":
413.5 mm (16.28 in)
 3. Measure distance "B" with caliper.
Distance "B":
107.00 mm (4.21 in)
 4. Finger-tighten slide rail bolt ①.
 5. Measure distance "C".
Distance "C":
885.50 mm (34.86 in)
 6. Torque the RH slide rail bolts ①, ② and ③.
Torque: 32 - 54 N·m (3.3 - 5.4 kg-m, 24 - 39 ft-lb)
 7. Check distance "B" and "C" to confirm position, adjust if necessary.
 8. Position the LH slide assembly in the vehicle with roller in 2nd seating position and loosely install bolts ④, ⑤ and ⑥.
 9. Measure distance "D".
Distance "D":
561.50 mm (22.11 in)
 10. Measure distance "E" between the right hand inner edge of each slide rail.
Distance "E":
1,110.00 mm (43.70 in)

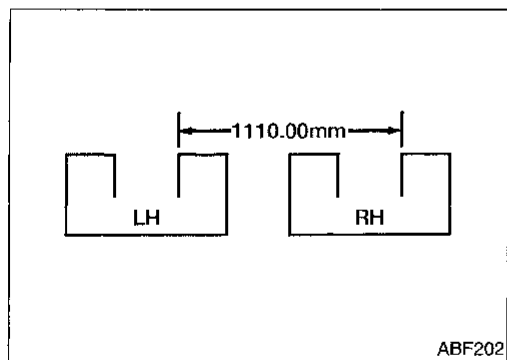

- Measure in two locations where no latch opening exists.

11. Hand-tighten bolts ④, ⑤ and ⑥.
12. Check distance "E" at several points along the slide rails, and adjust **only** the LH slide rail if necessary.
13. Torque the LH slide rail bolts ④, ⑤ and ⑥.
Torque: 32 - 54 N·m (3.3 - 5.4 kg-m, 24 - 39 ft-lb)
14. Install the 3rd seat through side door.
 - Torque front 2 bolts of 3rd seat while it is in 2nd seat position.
Torque: 34 - 46 N·m (3.5 - 4.7 kg-m, 25 - 34 ft-lb)
 - Slide the 3rd seat to full rear position.
 - Hand-start all remaining bolts.

SEAT

3rd Seat (Cont'd)

- Torque rear position bolts, **inner bolts first**.
☞: **34 - 46 N·m (3.5 - 4.7 kg-m, 25 - 34 ft-lb)**
- 15. Check slide release effort.
- 16. Check slide effort.
- 17. Install all remaining slide rail bolts.
- 18. From front to rear, tighten the slide rail bolts.
☞: **32 - 54 N·m (3.3 - 5.4 kg-m, 24 - 39 ft-lb)**
- 19. Place the 3rd bench seat in the 2nd seating position and remove the 3rd bench seat.
- 20. Install the floor carpeting.
- 21. Install the 3rd seat through side door.
 - Torque front 2 bolts in 2nd seat position.
☞: **34 - 46 N·m (3.5 - 4.7 kg-m, 25 - 34 ft-lb)**
 - Slide the 3rd seat to full rear position.
 - Hand-start all remaining bolts.
 - Torque rear position bolts, **inner bolts first**.
☞: **34 - 46 N·m (3.5 - 4.7 kg-m, 25 - 34 ft-lb)**
- 22. Check slide release effort. Make adjustments as necessary.
- 23. Check slide effort. Make adjustments as necessary.

Slide release effort check

1. Remove plastic slide release handle to expose hex shaft.
2. Check slide release effort with torque wrench and hex socket.

Release effort:

2.0 - 9.0 N·m (20 - 92 kg-cm, 17 - 80 in-lb)

- Torque value is read when the 3rd seat can just begin to move.
- Measure effort at all five latch positions.

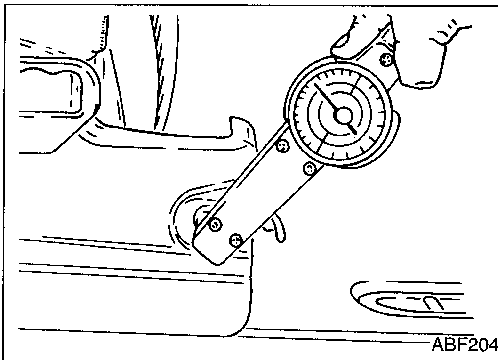

3. If release effort is not within the specified value, adjust the tension of cable system.

- Loosen bolt on adjuster assembly.
- Slide the bolt in the slotted holder as needed to adjust slide release effort. (Tightening the cable will reduce slide release effort.)
- Tighten the bolt.

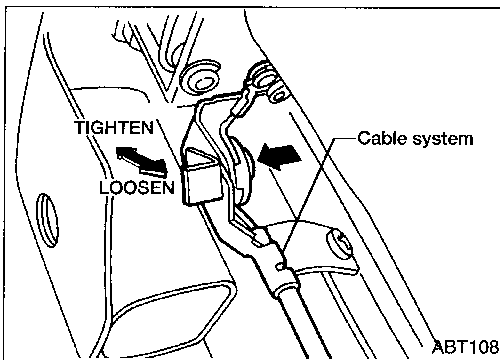

Slide effort check

- Check slide effort.

Maximum starting effort:

118 N (12 kg, 26 lb)

(measured at center of the 3rd seat with slide release handle fully up)

- Measure rearward starting effort at front four latch positions with a force gauge (spring scale).
- After starting efforts have been taken, slide the 3rd seat five times the full length of the slide rails. If at anytime the seat binds, stop and take the starting effort at that location.

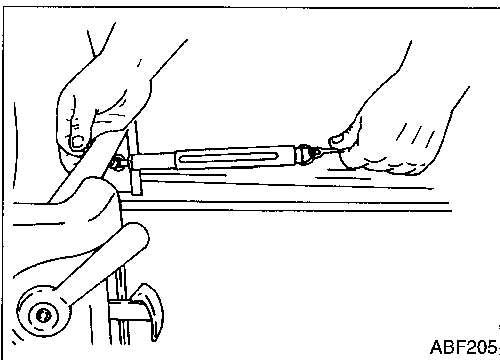

SEAT

3rd Seat (Cont'd)

- Adjust LH slide rail side-to-side for excessive slide effort.
- If force is too high, adjust only LH slide rail until force is correct.

GI

MA

EM

LC

EC

FE

AT

FA

RA

BR

ST

RS

BT

HA

EL

IDX

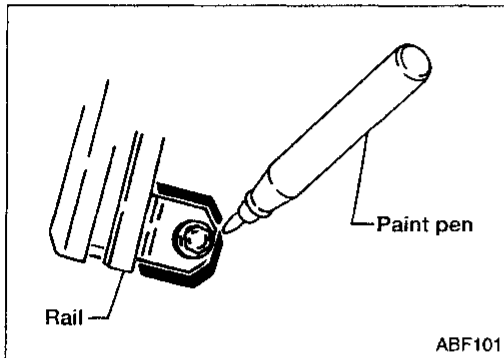

Removal and installation of the same rails

1. Mark the rails' positions on the floor panel at the points of bolts ① to ⑥ before removing rails.
2. Loosen bolts and remove rails.
3. Install rails so that they will align with the marks made during step 1.
Torque bolts ① to ⑥.
□: 32 - 54 N·m (3.3 - 5.4 kg-m, 24 - 39 ft-lb)
4. Follow the procedures beginning with step 14 in "Installation for new rails", then perform "Slide release effort check" and "Slide effort check".

SEAT 3rd Seat (Cont'd)

SEC. 880A

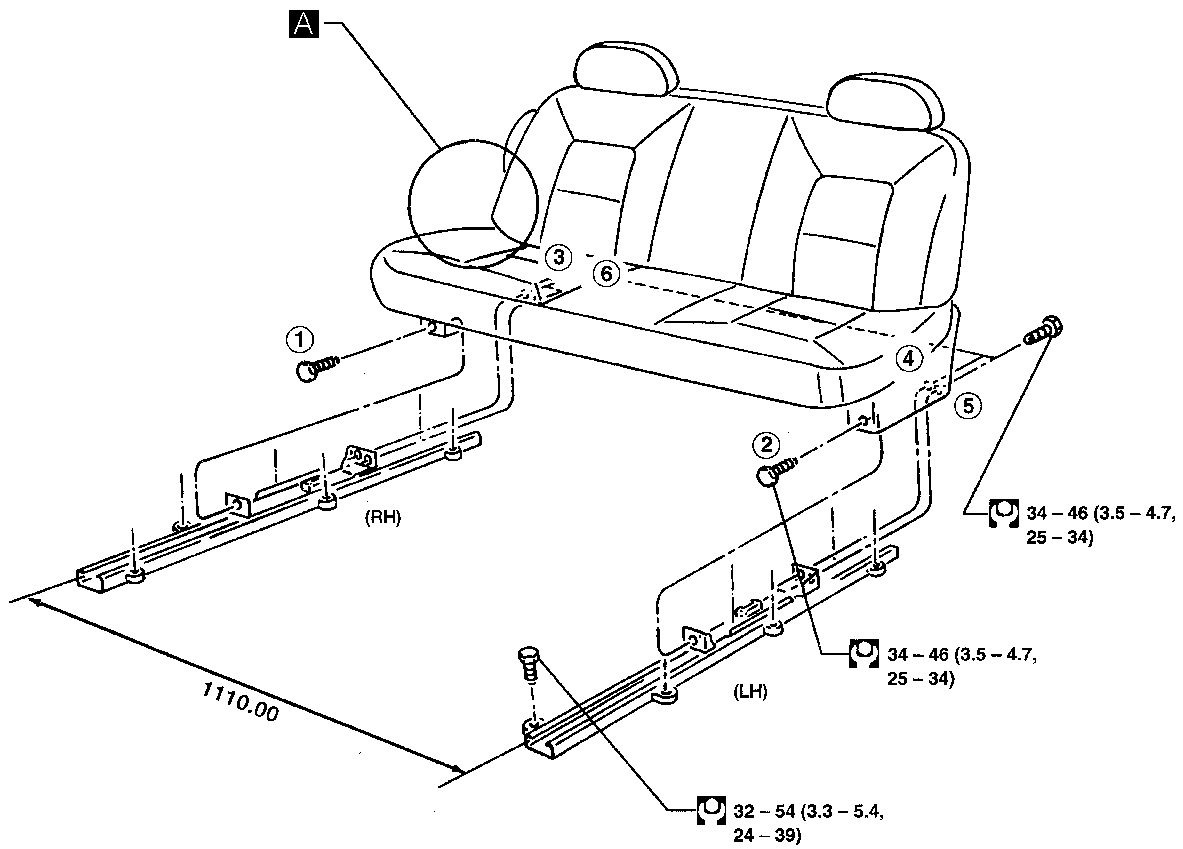

Important: Follow installation sequence and procedure

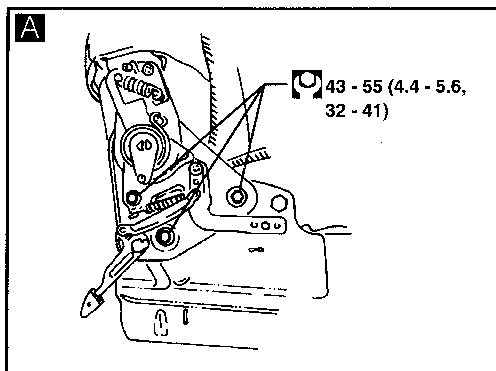

: N·m (kg-m, ft-lb)

ABT214

BT-42

1142

SUNROOF

- Before any repair, check sunroof operation and lid alignment.
- Handle finisher plate and glass lid with care so as not to cause damage.
- To ease installation, mark each point before removal.
- Always synchronize the sunroof motor in the closed position.

GI

CAUTION:

- **Always work with a helper.**
- **Remove sunroof frame from rear door opening.**

MA

REMOVAL AND INSTALLATION

EM

- ① Remove front side of roof trim up to room lamp.
- **Do not use excessive force. Take care not to damage roof trim.**
- ② Remove sunroof motor.
- ③ Open sunshade plate.
- ④ Remove sliding rail fixing screws.
- ⑤ Move sliding rail to back position.
- ⑥ Remove sunroof glass.
- ⑦ Disconnect four sunroof drain hoses from guide rail assembly.
- ⑧ Remove guide rail assembly with sliding rail and sunshade plate.
- Installation is basically the reverse order of removal.

LC

EC

FE

DISASSEMBLY AND ASSEMBLY — Guide rail assembly

AT

- ⑨ Separate guide rail assembly from sliding rail and sunshade plate.
- ⑩ Remove six rivets and sunroof motor bracket.
- ⑪ Remove ten metal clips securing cables to guide rail.
- ⑫ Remove cables.
- Assembly is basically the reverse order of disassembly.

FA

RA

BR

ST

RS

BT

HA

EL

IDX

SUNROOF

SEC. 736

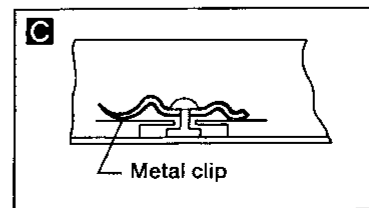
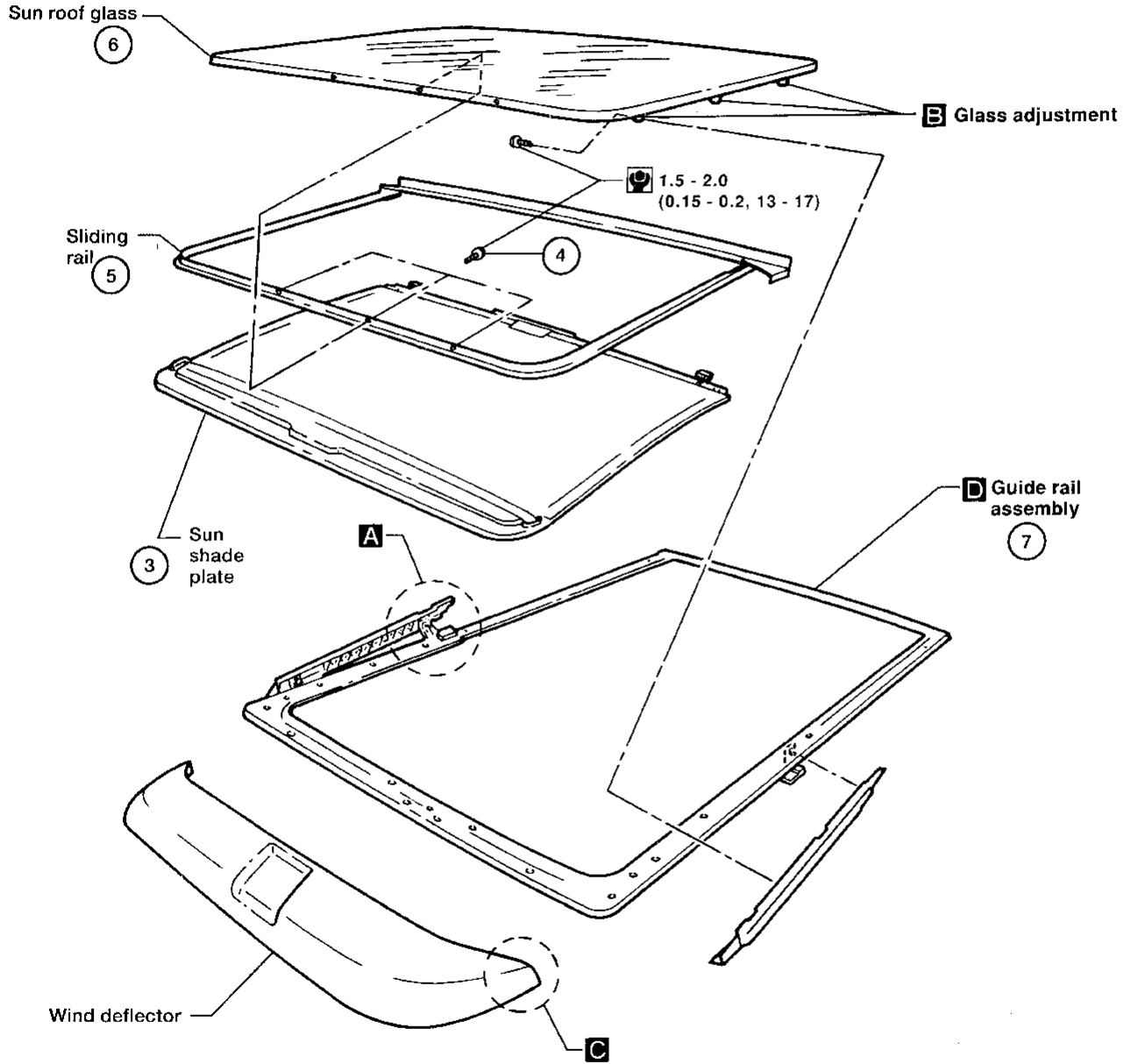
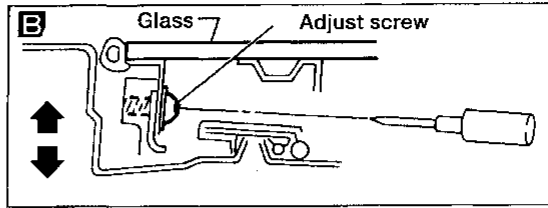
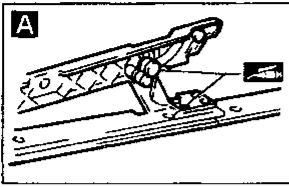



- : N·m (kg·m, in·lb)
- : Should be lubricated with grease

ABT134

SUNROOF

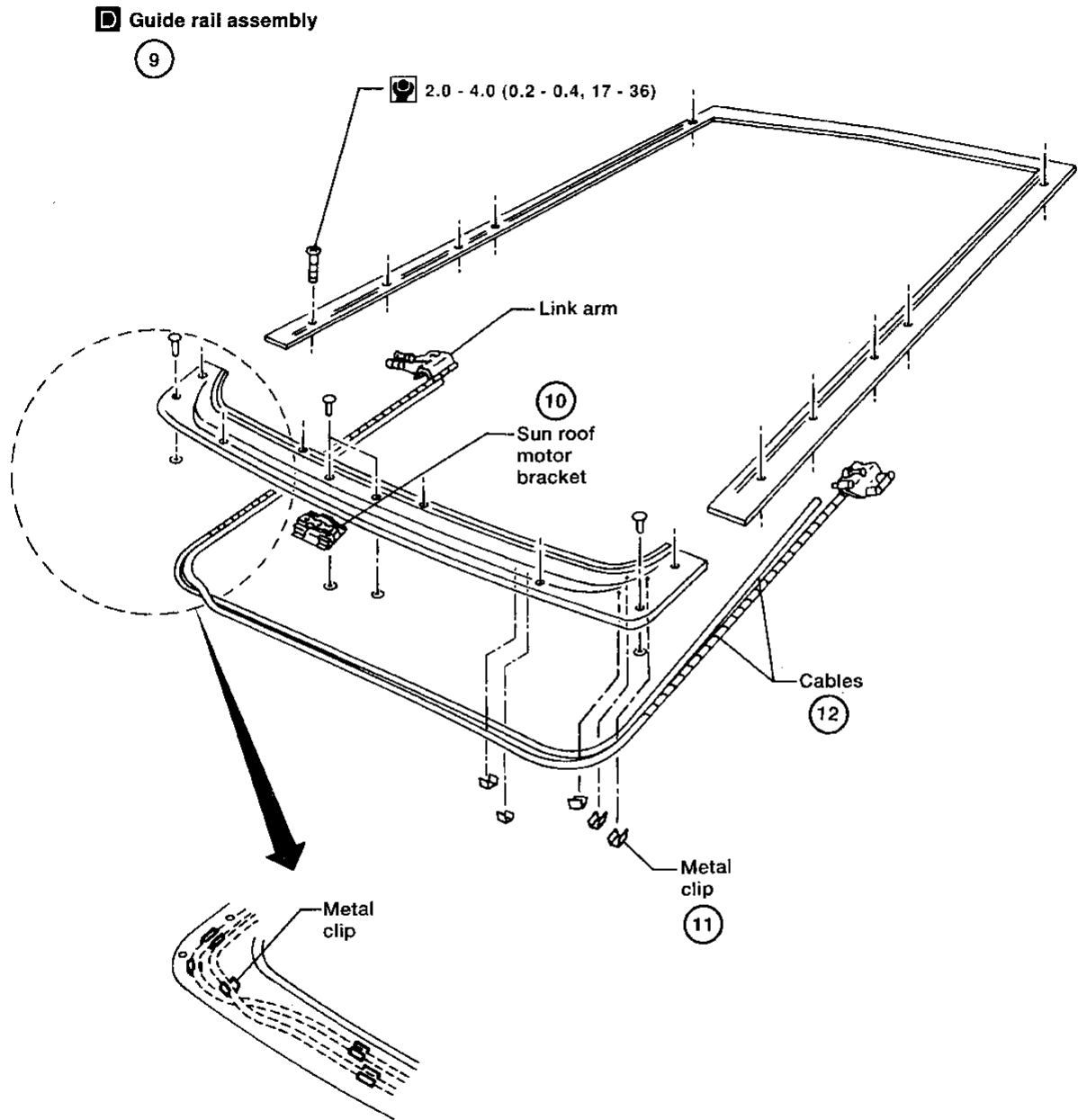
SEC. 736



 : N·m (kg-m, in-lb)

GI
MA
EM
LC
EC
FE
AT
FA
RA
BR
ST
RS
BT
HA
EL
IDX

SUNROOF

Trouble Diagnoses

DIAGNOSTIC TABLE

NOTE: For "Wiring Diagram", refer to "ELECTRIC SUNROOF" in EL section.

		Check items (Components)				
		Sunshade	Adjustment	Drain hoses	Weatherstrip	Link and wire assembly
	Reference page	BT-46	BT-47	BT-49	BT-49	BT-50
Symptom	Excessive wind noise		2		3	
	Water leaks		1	2	3	
	Sunroof rattles	1	1	4	2	3
	Excessive operation noise	1	1		2	3

The numbers in this table mean checking order.

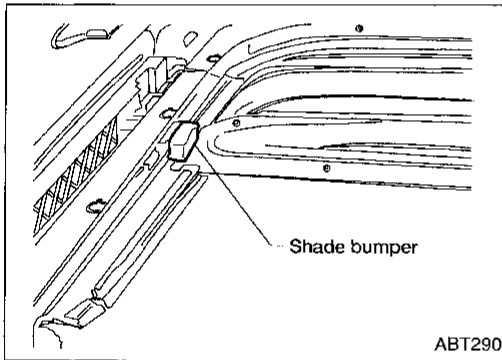

SUNSHADE

Visually inspect shade bumper for proper installation and function. If NG, replace sunshade.

SUNROOF

Trouble Diagnoses (Cont'd) ADJUSTMENT

If any gap or height difference between lid and roof is found, check lid fit and adjust as follows:

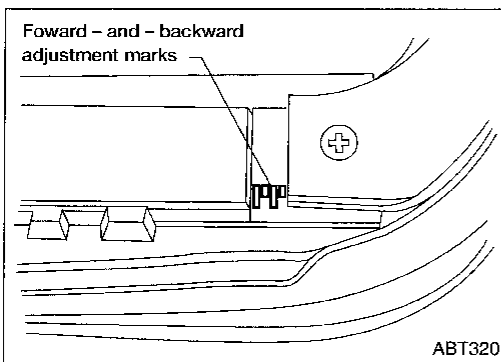
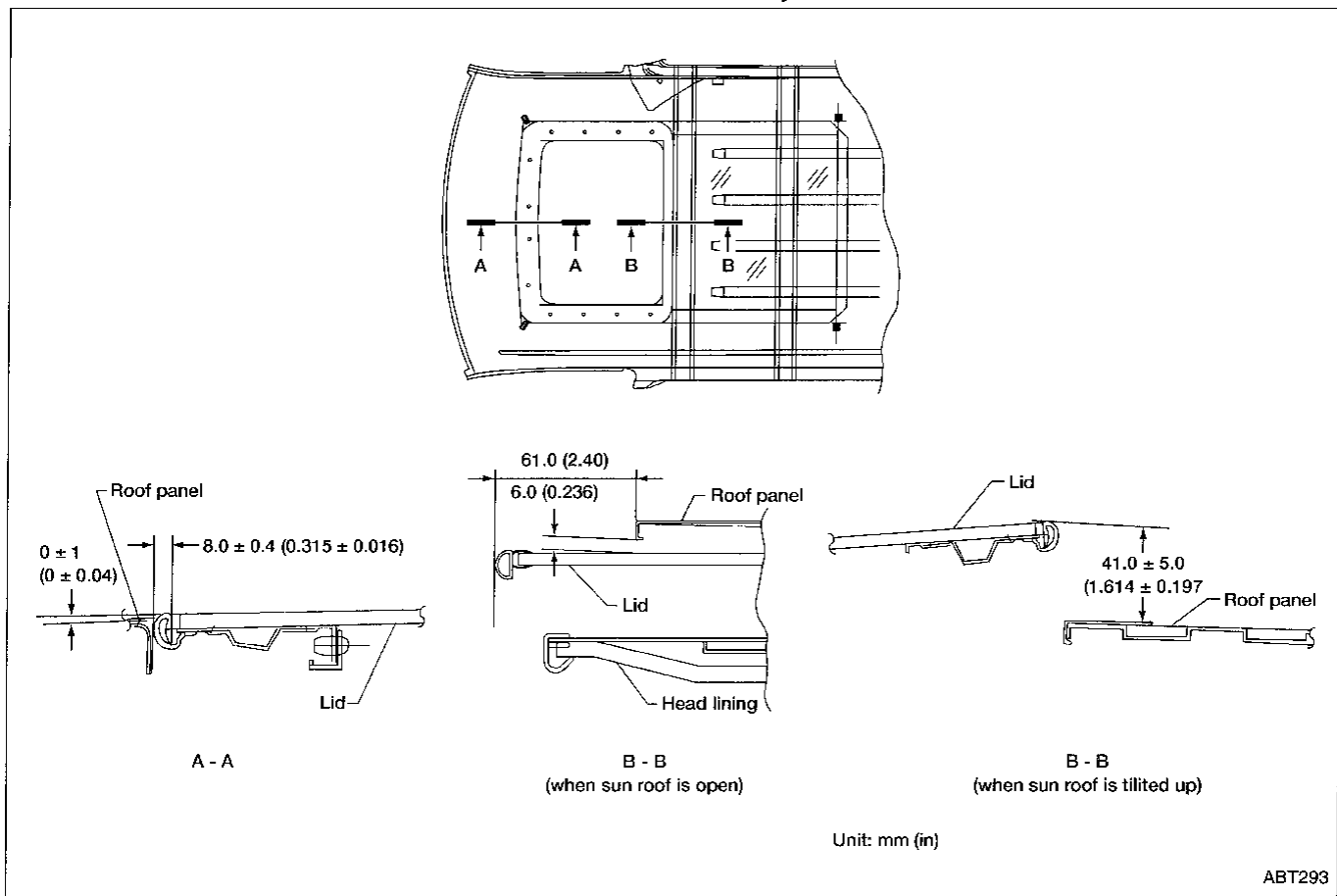

Gap adjustment

1. Tilt lid up.
2. Loosen lid securing bolts (3 each on left and right sides), then tilt lid down.
3. Adjust lid so it resembles "A-A" as shown in the figure above.
4. Tilt lid up and down until it is adjusted to "B-B" as shown in the figure above.
5. After adjusting lid, tilt lid up and tighten bolts.
6. Tilt lid up and down several times to check that it moves smoothly.

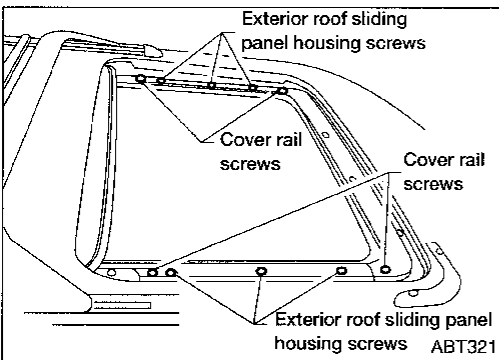

Fore and aft adjustment

1. Place the roof glass panel in the open position.
2. Loosen the four cover rail screws and the six exterior roof sliding panel housing screws which fasten the cover rails to the roof sliding panel housing.
3. Move the cover rails forward or backward as necessary, making sure that both sides are uniform to the forward-and-backward adjustment marks. Tighten the RH and LH cover rail screws. Tighten the exterior roof sliding panel housing screws.

SUNROOF

Trouble Diagnoses (Cont'd)

Height difference adjustment

1. Place the roof glass panel in the closed position.
2. Remove the three halo moulding screws.
3. Slide the halo moulding rearward to expose the six (three per side) roof glass panel screws.
4. Loosen the six roof glass panel screws and then tighten them so they are snug.
5. Lower the front of the roof glass so it is approximately 1mm (0.04 inch) below flush with the roof panel at the front corners. (Refer to procedure on BT-47.)
6. Raise the rear of the roof glass panel so it is approximately 1 mm (0.04 inch) above flush with the roof panel at the rear corners. (Refer to ADJUSTMENT, BT-47.)
7. Tighten the six roof glass panel screws.
8. Position the halo to the roof glass panel.
9. Install the three halo screws.

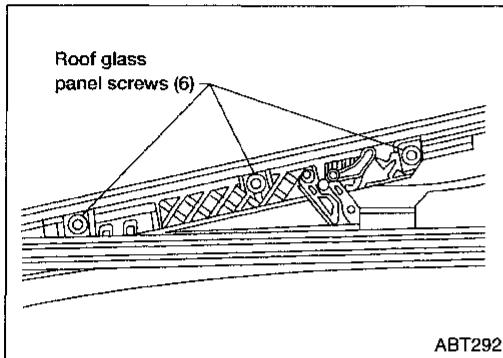
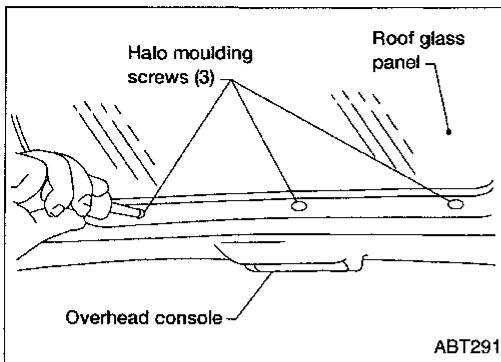

SUNROOF

Trouble Diagnoses (Cont'd)

DRAIN HOSES

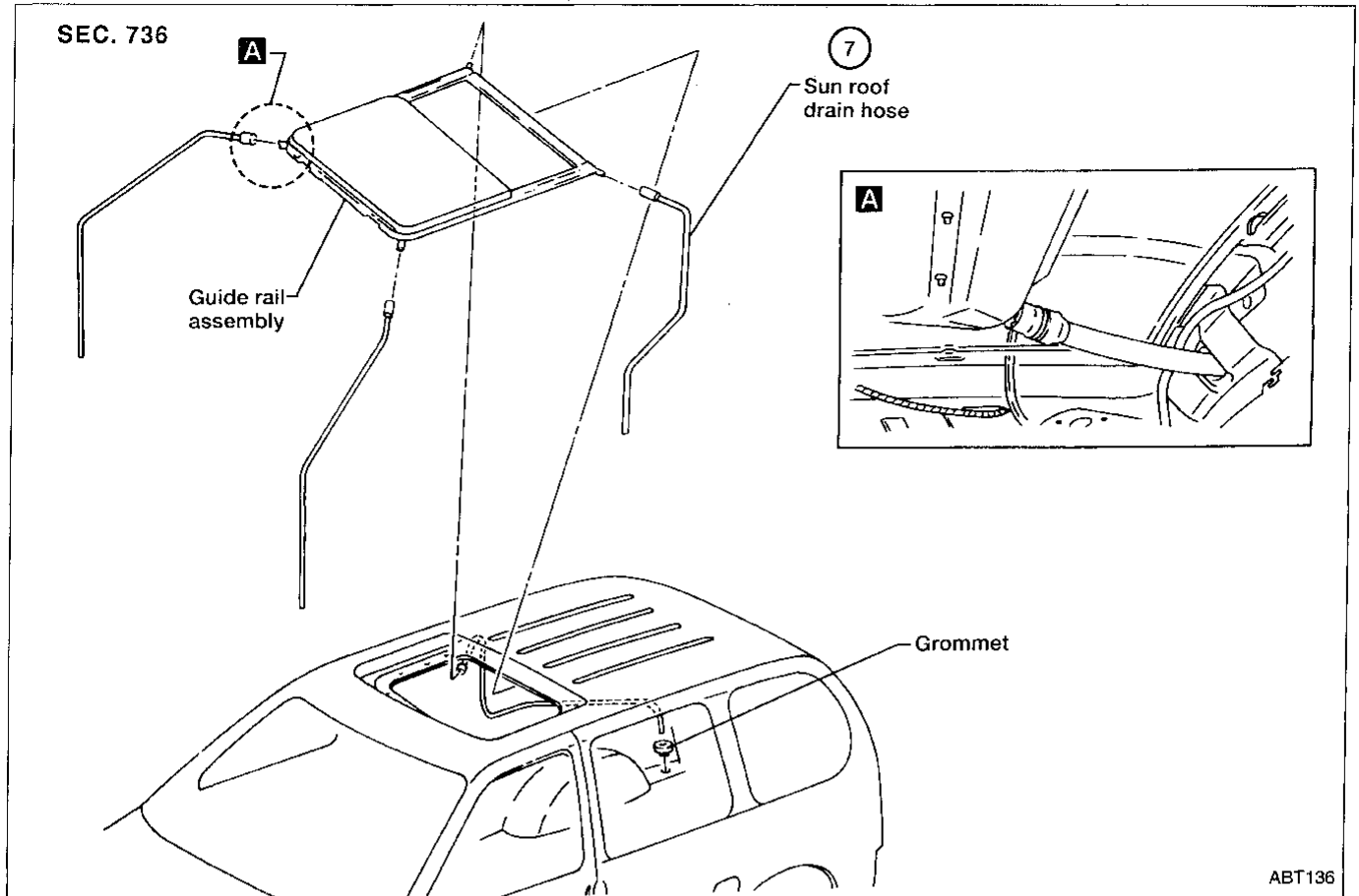

1. Remove headlining to access drain hose connections. Refer to "Roof Trim", "INTERIOR TRIM" (BT-26).
2. Check visually for proper connections, damage or deterioration. **A** (The figure shows only the front side.)
3. Remove drain hoses and check visually for any damage, cracks, or deterioration.
4. Pour water into drain hoses and find damaged portion.
 - If any damaged portion is found at each step, replace the damaged part.

WEATHERSTRIP

- In case of leakage around lid, close lid and pour water over lid to find damaged or gap portion.
- If gap is between weatherstrip and roof panel, perform gap adjustment. Refer to procedure on BT-47.
- If gap is between weatherstrip and lid, or if weatherstrip is flattened, damaged or deteriorated, replace lid assembly. (Weatherstrip is not serviceable.)

SUNROOF

Trouble Diagnoses (Cont'd)

LINK AND WIRE ASSEMBLY

NOTE:

Before replacing a suspect part, carefully ensure it is the source of noise being experienced.

1. Check link to determine if coating film has peeled off to such an extent that substrate is visible. Check also to determine if link is the source of noise. If it is, replace it.
2. Visually check to determine if a sufficient amount of grease has been applied to link arm. If not, add grease as required.
3. Check wire for any damage or deterioration. If damaged, replace guide rail assembly. Refer to BT-51.

WINDSHIELD AND WINDOWS

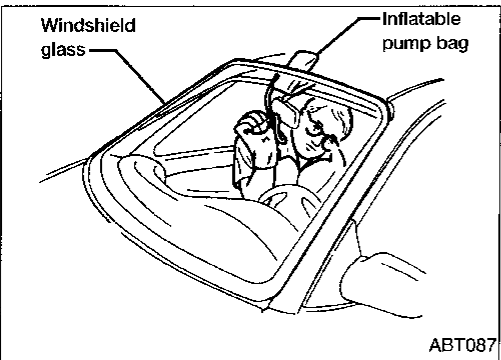
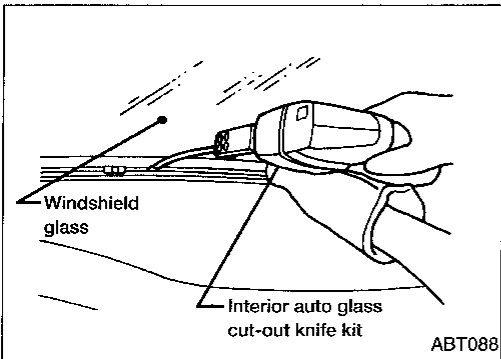
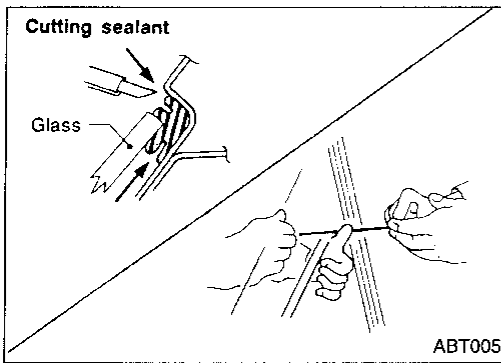

REMOVAL

After removing moldings, remove glass using piano wire or power cutting tool and an inflatable pump bag.

WARNING:

When cutting the glass from the vehicle, always wear safety glasses and heavy gloves to help prevent glass splinters from entering your eyes or cutting your hands.

CAUTION:

- Be careful not to scratch the glass when removing.
- Do not set or stand the glass on its edge. Small chips may develop into cracks.

INSTALLATION

- Use genuine Nissan Urethane Adhesive Kit or equivalent and follow the instructions furnished with it.
- While the urethane adhesive is curing, open a door window. This will prevent the glass from being forced out by passenger compartment air pressure when a door is closed.
- The molding must be installed securely so that it is in position and leaves no gap.
- Inform the customer that the vehicle should remain stationary until the urethane adhesive has completely cured (preferably 24 hours). Curing time varies with temperature and humidity.

WARNING:

- Keep heat and open flames away as primers and adhesive are flammable.
- The materials contained in the kit are harmful if swallowed, and may irritate skin and eyes. Avoid contact with the skin and eyes.
- Use in an open, well ventilated location. Avoid breathing the vapors. They can be harmful if inhaled. If affected by vapor inhalation, immediately move to an area with fresh air.
- Driving the vehicle before the urethane adhesive has completely cured may affect the performance of the windshield in case of an accident.

CAUTION:

- Do not use an adhesive which is past its usable term. Shelf life of this product is limited to six months after the date of manufacture. Carefully adhere to the expiration or manufacture date printed on the box.
- Keep primers and adhesive in a cool, dry place. Ideally, they should be stored in a refrigerator.
- Do not leave primers or adhesive cartridge unattended with their caps open or off.
- The vehicle should not be driven for at least 24 hours or until the urethane adhesive has completely cured. Curing time varies depending on temperature and humidities. The curing time will increase under higher temperatures and lower humidities.

GI
MA
EM
LC
EC
FE
AT
FA
RA
BR
ST
RS
BT
HA
EL
IDX

Windshield and Rear Window

Install spacer to panel.
Windshield

425 (16.73)
Unit: mm (in)

Install moulding to glass.
Rear window

Install molding fastener for windshield.
When installing it, heat body panel and fastener to approx. 30 to 40°C (86 to 104°F).

Upper & side molding fasteners

Fastener
Panel
Double-faced adhesive tape

ABT275

Glass side
Install open cell foam dam

Windshield

8 - 9 (0.31 - 0.35) Vehicle center
8 - 9 (0.31 - 0.35)
Joint portion

Rear window

8 - 9 (0.31 - 0.35) Vehicle center
8 - 9 (0.31 - 0.35)
Joint portion

Open cell foam dam
Double-faced adhesive tape
Glass
8 - 9 (0.31 - 0.35)

Apply urethane adhesive evenly.
Windshield and rear window

7 - 8 (0.28 - 0.31)
12 - 15 (0.47 - 0.59)
Open cell foam dam
Glass

Unit: mm (in)

ABT241

REPAIRING WATER LEAKS FOR WINDSHIELD

Leaks can be repaired without removing and reinstalling glass.

If water is leaking between caulking material and body or glass, determine the extent of leakage. This can be done by applying water while pushing glass outward.

To stop the leak, apply primer (if necessary) and then sealant to the leak point.

WINDSHIELD AND WINDOWS

Side Window (1st)

SEC. 830

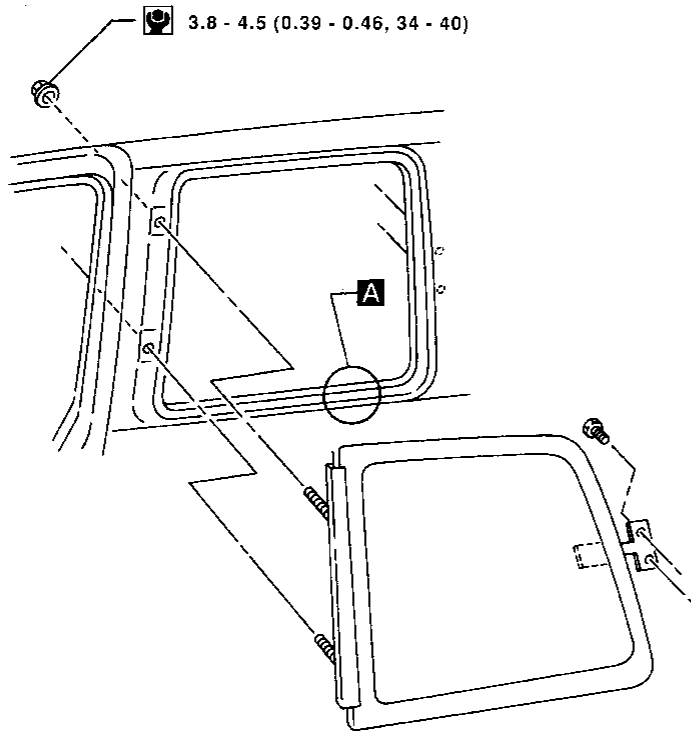

: N·m (kg-m, in-lb)

ABT137

GI
MA
EM
LC
EC
FE
AT
FA
RA
BR
ST
RS
BT
HA
EL
IDX

WINDSHIELD AND WINDOWS

Side Window (2nd)

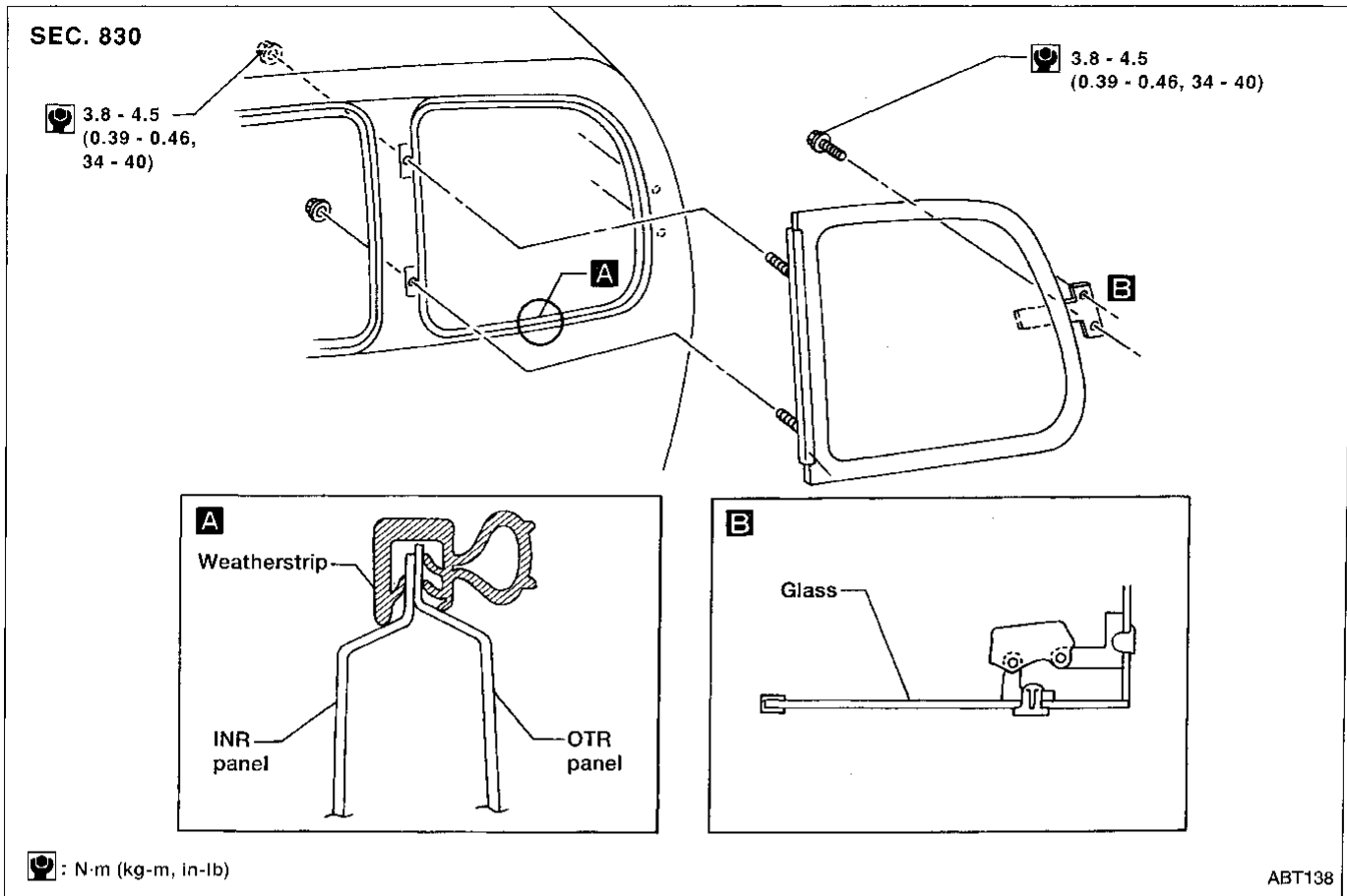

INSTALLATION

1. Use the switch to place the cable in the open position.
2. Attach the mechanism to the glass and tighten the attaching screw.
3. Loosely attach mechanism to the body with bolts.
- **Do not tighten the bolts.**
4. Use the switch to place window in the closed position.
5. From outside of vehicle, push on the glass at its attaching point.
6. Tighten bolts.
7. Check operation.

CAUTION:

Failure to follow this procedure may cause damage to control and wire assembly.

MIRROR

Door Mirror

- For removal of the door mirror, refer to BT-33.

SEC. 963

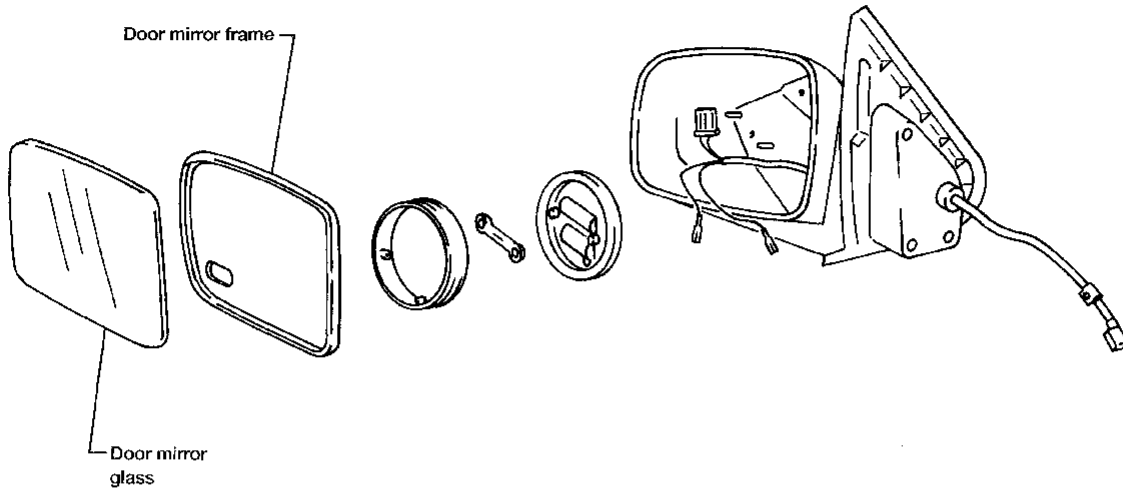

Mirror glass replacement

CAUTION:

Do not exceed specified temperature or time limit. Excess heat or duration may cause damage to the mirror housing.

• Removal

1. Use a heat lamp (at least 500 watts) to thoroughly warm the frame edge of the door mirror glass to approximately 70 C (159 F) for three minutes.

2. Insert a stiff blade scraper between the mirror glass and the frame. Pry the glass loose.
3. Remove any remaining adhesive (butyl tape) from the mounting surface on the frame.

• Installation

1. Install butyl/adhesive tape (2 pieces) on the frame.
2. Warm the mirror glass frame edge thoroughly with a heat lamp.
3. Position mirror glass on frame. Carefully press on the mirror glass to seat it in place.

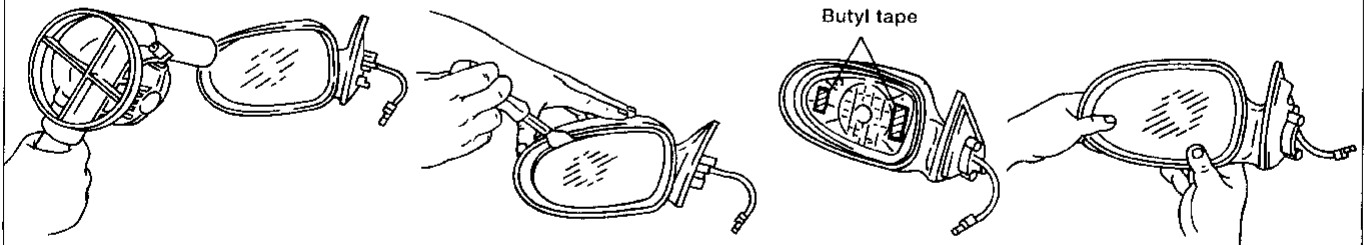

ABT142

GI

MA

EM

LG

EC

FE

AT

FA

RA

BR

ST

RS

BT

HA

EL

IDX

MIRROR

Rearview Mirror

REMOVAL

Remove rearview mirror by pushing deflect spring with screwdriver as shown in the figure.

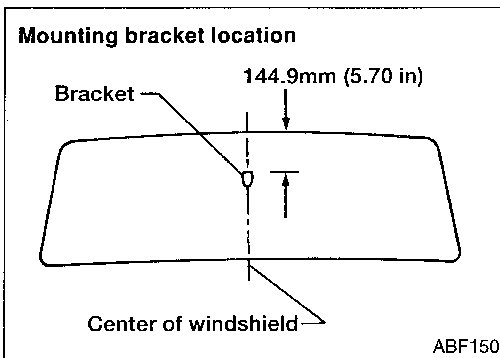
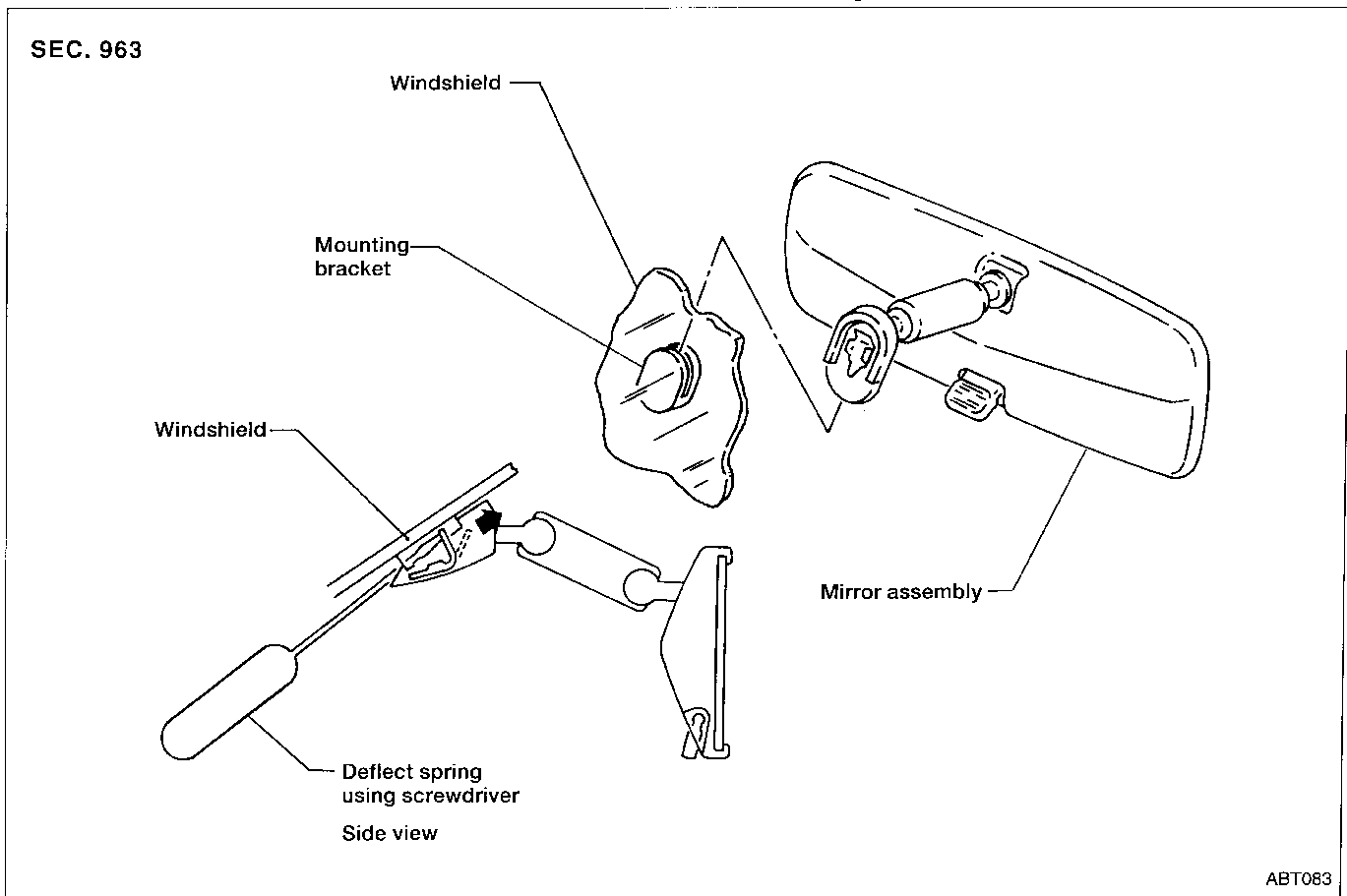

INSTALLATION

1. Install mounting bracket as follows:
 - (1) Determine mounting bracket position on windshield by measuring from top of windshield to top of mounting bracket as shown in the figure.
 - (2) Mark location on outside of windshield with wax pencil or equivalent.
 - (3) Clean attaching point on inside of windshield with an alcohol-saturated paper towel.
 - (4) Sand bonding surface of mounting bracket with sandpaper (No. 320 or No. 360).
 - (5) Clean bonding surface of mounting bracket with an alcohol-saturated paper towel.
 - (6) Apply Loctite Adhesive 11067-2 or equivalent to bonding surface of mounting bracket.
 - (7) Install mounting bracket at premarked position and press mounting bracket against glass for 30 to 60 seconds.
 - (8) After five minutes, wipe off excess adhesive with an alcohol-moistened paper towel.
2. Install rearview mirror.

BODY ALIGNMENT

- All dimensions indicated in figures are actual ones.
- When using a tracking gauge, adjust both pointers to equal length. Make sure there is no free play.
- When a measuring tape is used, check to be sure there is no elongation, twisting or bending.
- Measurements should be taken at the center of the mounting holes.
- All measurements and mounting hole diameters are expressed in millimeters(mm).
- An asterisk (*) following the value at the measuring point indicates that the measuring point on the other side is symmetrically the same value.
- The coordinates of the measurement points are the distances measured from the standard line of "X", "Y" and "Z".

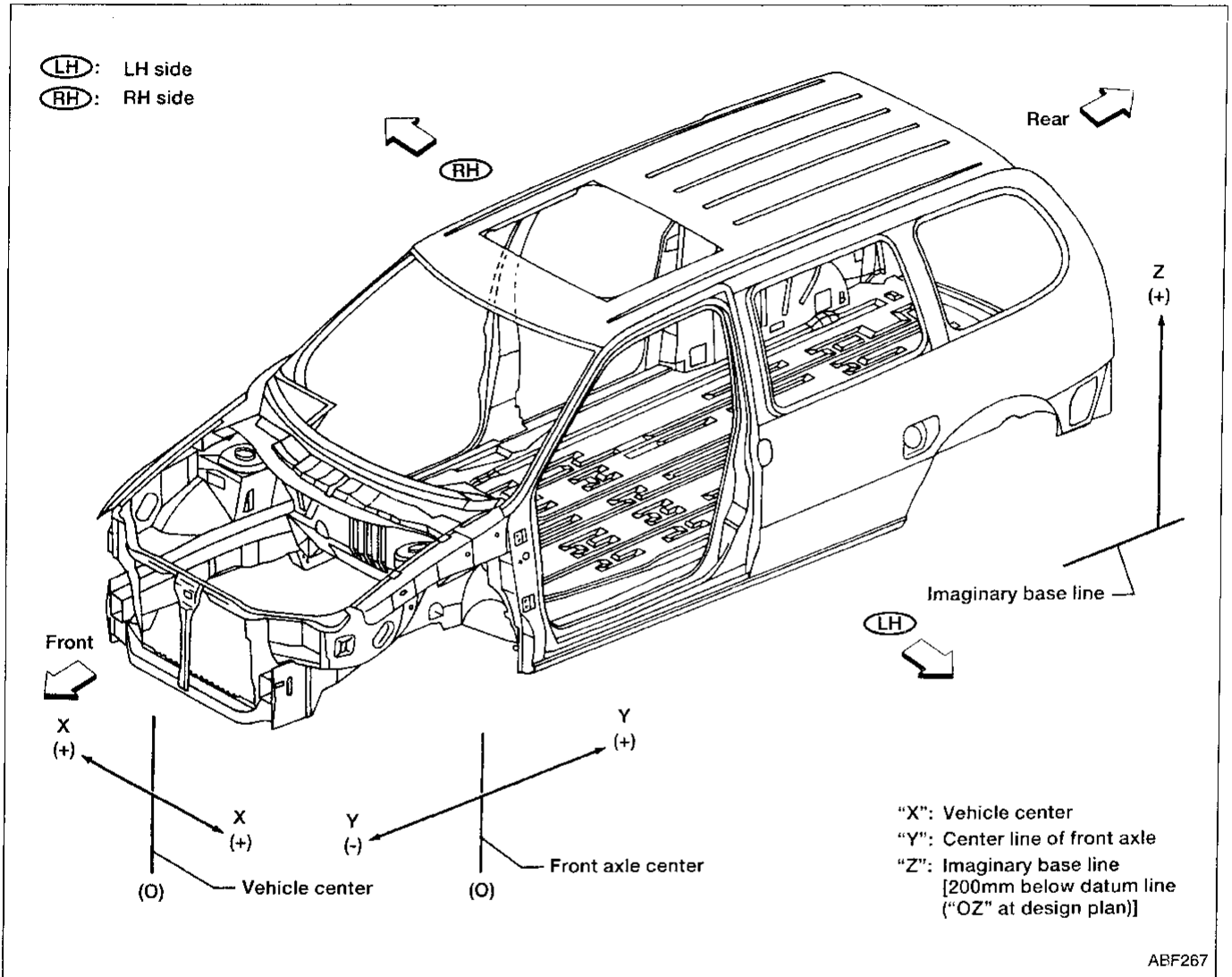

GI
MA
EM
LC
EC
FE
AT
FA
RA
BR
ST
RS
BT
HA
EL
DX

BODY ALIGNMENT

Engine Compartment

MEASUREMENT

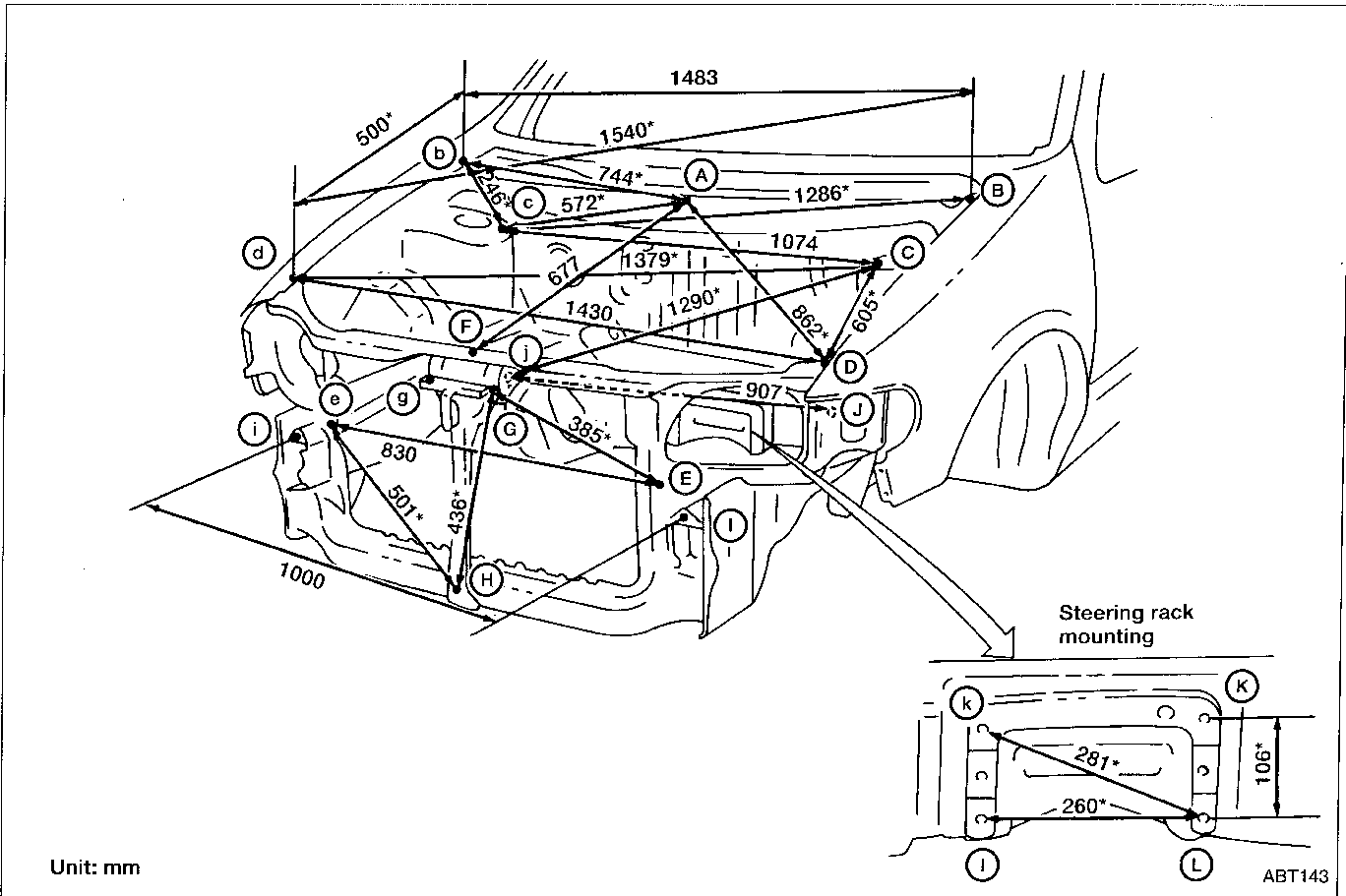

BODY ALIGNMENT

Engine Compartment (Cont'd)

MEASUREMENT POINTS

Unit: mm

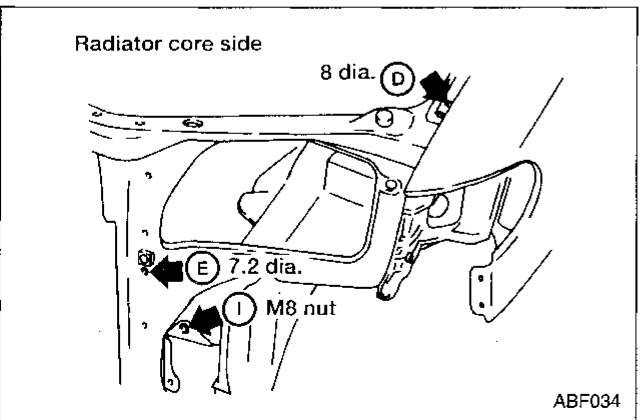
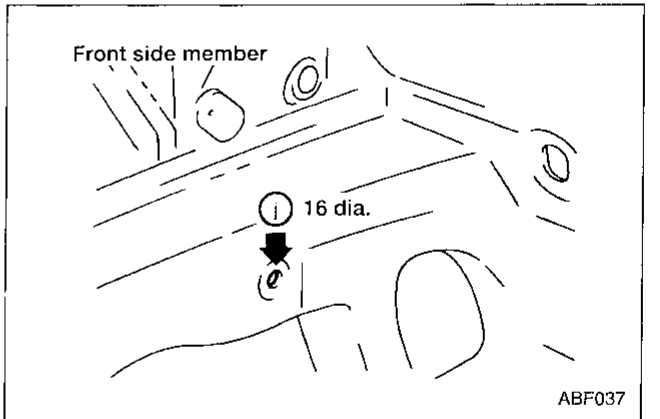
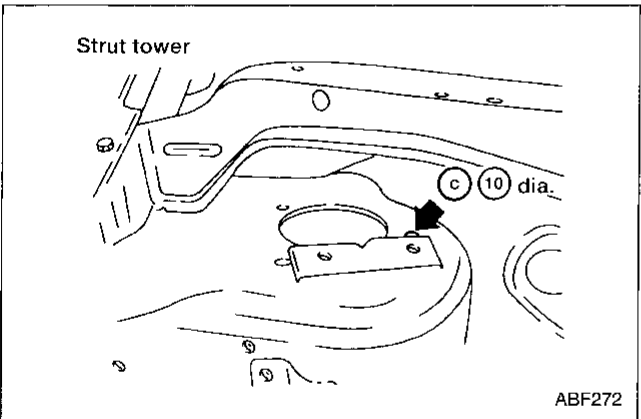
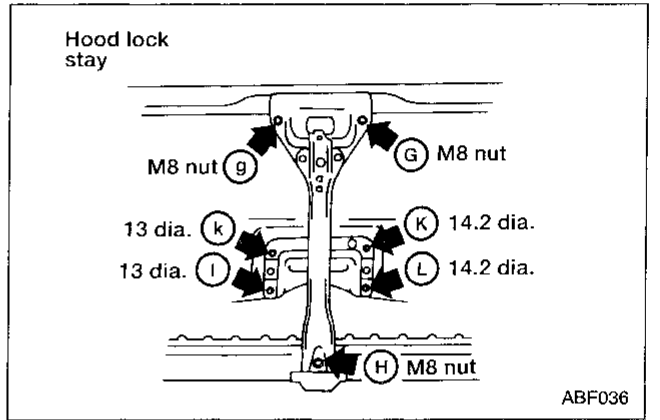
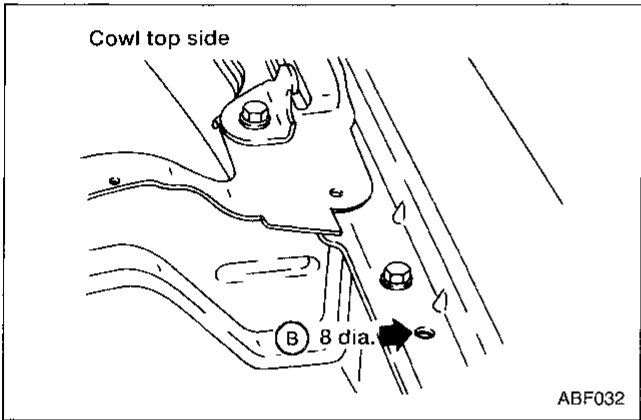
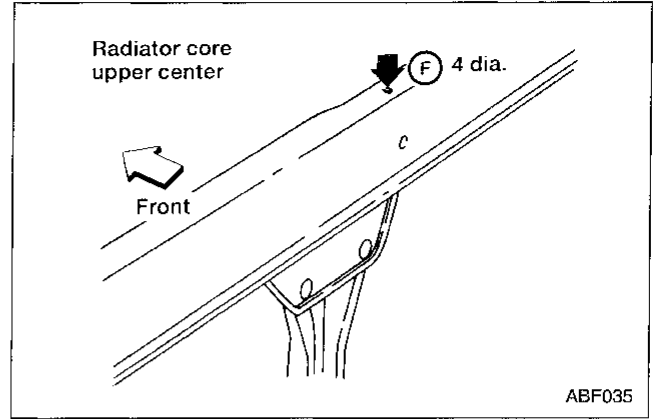
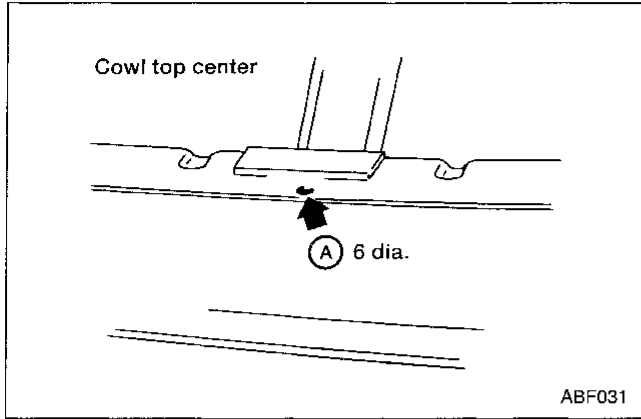

GI
MA
EM
LC
EC
FE
AT
FA
RA
BR
ST
RS
BT
HA
EL
IDX

BODY ALIGNMENT

MEASUREMENT

Underbody

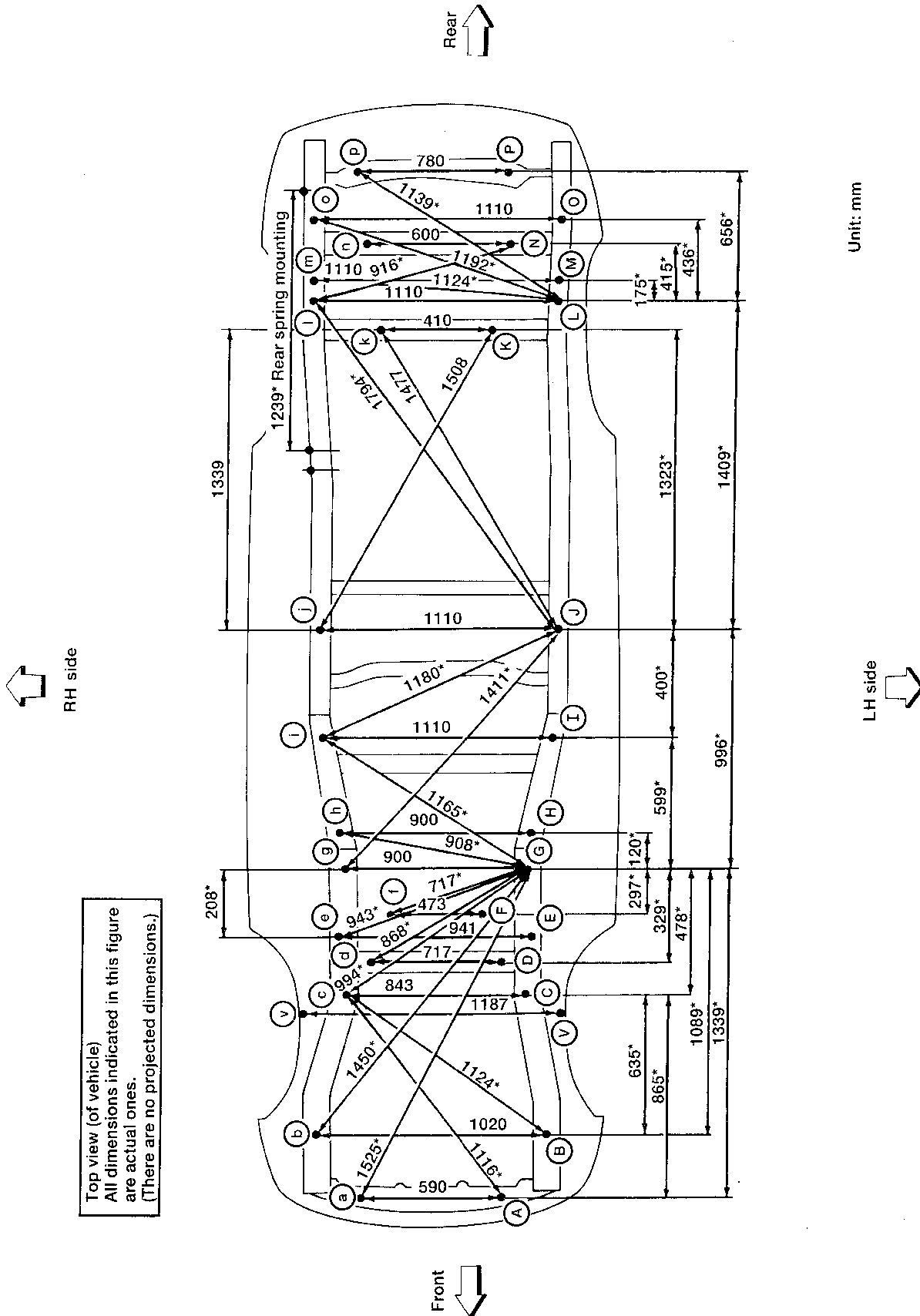

Unit: mm

Top view (of vehicle)
All dimensions indicated in this figure
are actual ones.
(There are no projected dimensions.)

BODY ALIGNMENT

Underbody (Cont'd)

MEASUREMENT POINTS

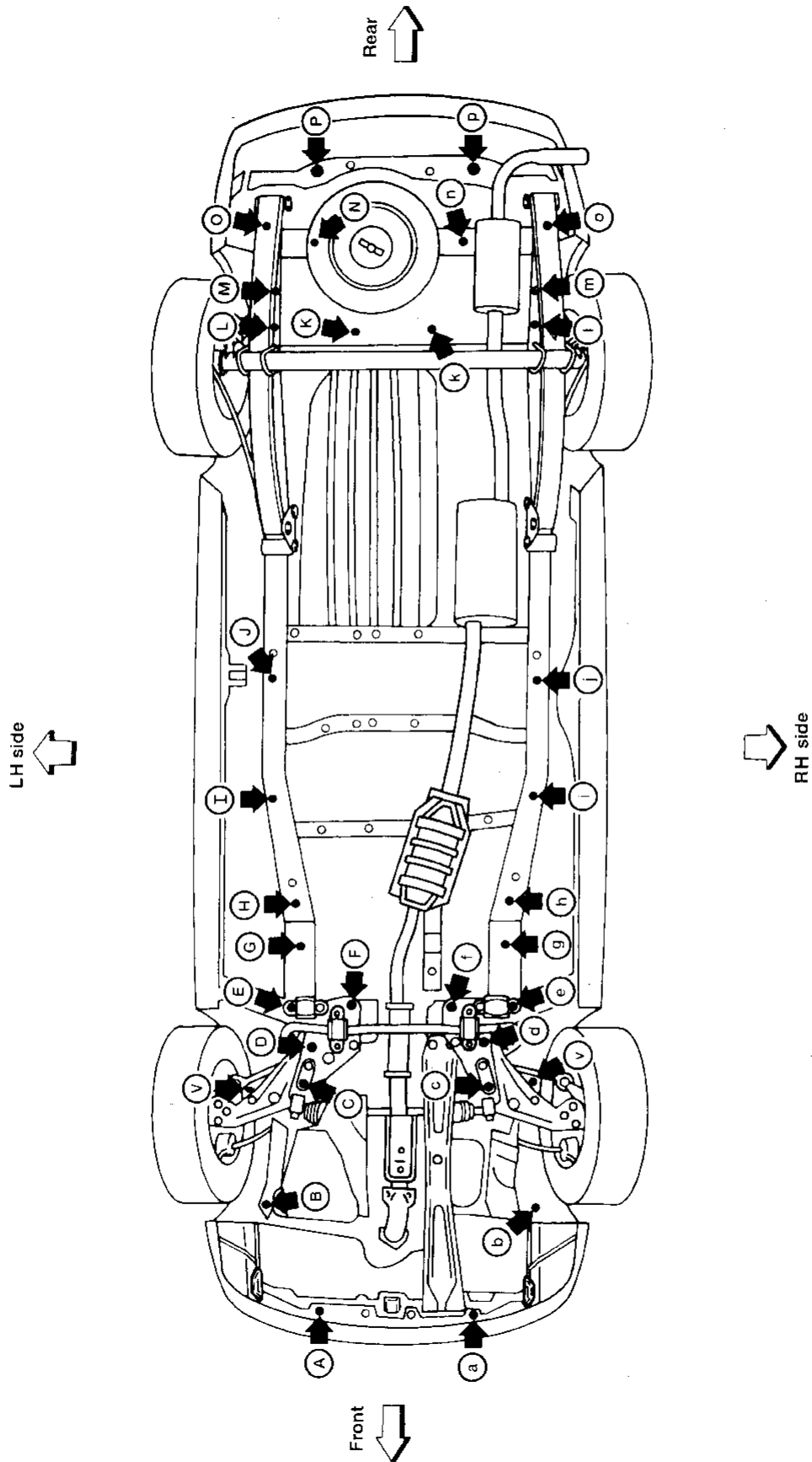

- GI
- MA
- EM
- LC
- EC
- FE
- AT
- FA
- RA
- BR
- ST
- RS
- BT**
- HA
- EL
- IDX

BODY ALIGNMENT

Underbody (Cont'd)

Front side member and front extension

Coordinates:

- (A), (a)
X: 295
Y: -750
Z: 168.8
- (B), (b)
X: 510
Y: -500
Z: 310
- (C), (c)
X: 421.5
Y: 105
Z: 137.7
- (D), (d)
X: 358.5
Y: 264.4
Z: 170.5
- (E), (e)
X: 470.5
Y: 373.3
Z: 182.2
- (F), (f)
X: 236.5
Y: 373.3
Z: 182.2
- (G), (g)
X: 450
Y: 580
Z: 186.5
- (H), (h)
X: 450
Y: 700
Z: 186.5
- (I), (i)
X: 555
Y: 1170
Z: 182
- (J), (j)
X: 555
Y: 1570
Z: 199.7

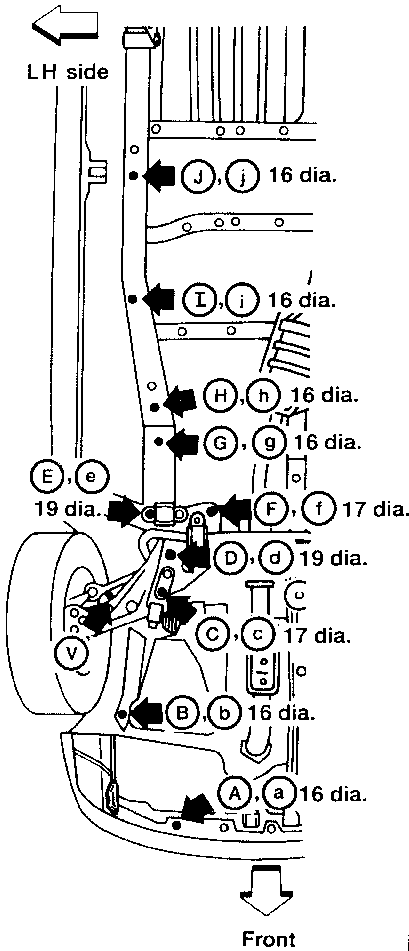

Center side member and rear extension

Coordinates:

- (K)
X: 235
Y: 2850
Z: 303.8
- (k)
X: 175
Y: 2850
Z: 303.8
- (L), (l)
X: 555
Y: 2975
Z: 307
- (M), (m)
X: 555
Y: 3150
Z: 315.1
- (N), (n)
X: 300
Y: 3300
Z: 347.5
- (O), (o)
X: 555
Y: 3410
Z: 328.1
- (P), (p)
X: 390
Y: 3610
Z: 295.6

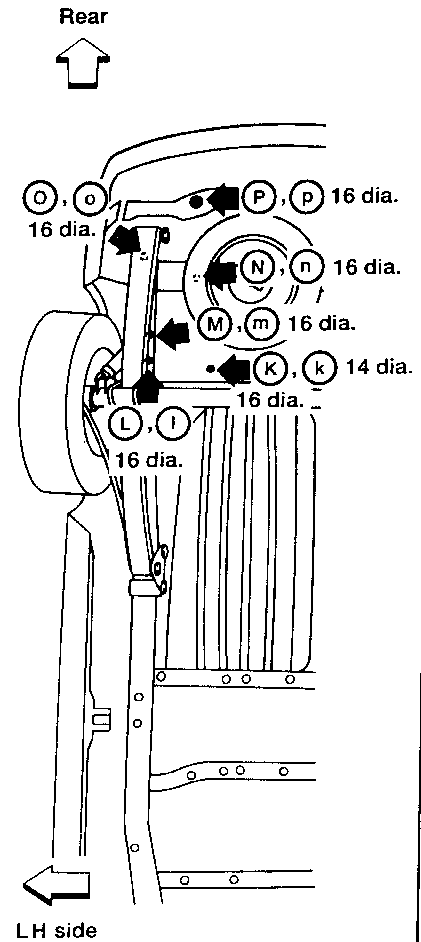

Front strut tower centers

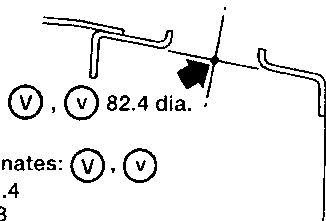

- Coordinates: (V), (v)
X: 593.4
Y: 14.8
Z: 803.1

Unit: mm