

AUTOMATIC TRANSAXLE

SECTION AT

CONTENTS

TROUBLE DIAGNOSIS - INDEX	4	Road Test.....	66
Alphabetical & P No. Index for DTC	4	TROUBLE DIAGNOSIS - GENERAL	
PRECAUTIONS	6	DESCRIPTION	83
Precautions for Supplemental Restraint System (SRS) "AIR BAG" and "SEAT BELT PRE-TENSIONER"	6	Symptom Chart.....	83
Precautions for On Board Diagnostic (OBD) System of A/T and Engine.....	6	TCM Terminals and Reference Value.....	95
Precautions	6	TROUBLE DIAGNOSIS FOR POWER SUPPLY	100
Service Notice or Precautions	8	Wiring Diagram - AT - MAIN.....	100
Wiring Diagrams and Trouble Diagnosis.....	9	DTC P0705 PARK/NEUTRAL POSITION SWITCH ...	103
PREPARATION	10	Description	103
Special Service Tools	10	Wiring Diagram - AT - PNP/SW.....	105
Commercial Service Tools	12	Diagnostic Procedure	106
OVERALL SYSTEM	14	Component Inspection.....	109
A/T Electrical Parts Location	14	DTC P0710 A/T FLUID TEMPERATURE SENSOR	
Circuit Diagram	15	CIRCUIT	110
Cross-sectional View	16	Description	110
Hydraulic Control Circuit.....	17	Wiring Diagram - AT - FTS.....	112
Shift Mechanism	18	Diagnostic Procedure	113
Control System	27	Component Inspection.....	116
Control Mechanism.....	29	DTC P0720 VEHICLE SPEED SENSOR.A/T	
Control Valve	33	(REVOLUTION SENSOR)	117
ON BOARD DIAGNOSTIC SYSTEM		Description	117
DESCRIPTION	35	Wiring Diagram - AT - VSSA/T	119
Introduction	35	Diagnostic Procedure	120
OBD-II Function for A/T System.....	35	Component Inspection.....	122
One or Two Trip Detection Logic of OBD-II	35	DTC P0725 ENGINE SPEED SIGNAL	123
OBD-II Diagnostic Trouble Code (DTC).....	35	Description	123
Malfunction Indicator Lamp (MIL).....	38	Wiring Diagram - AT - ENGSS	124
CONSULT-II	39	Diagnostic Procedure	125
Diagnostic Procedure Without CONSULT-II.....	48	DTC P0731 A/T 1ST GEAR FUNCTION	127
TROUBLE DIAGNOSIS - INTRODUCTION	55	Description	127
Introduction	55	Wiring Diagram - AT - 1ST	130
Work Flow.....	59	Diagnostic Procedure	131
TROUBLE DIAGNOSIS - BASIC INSPECTION	61	Component Inspection.....	132
A/T Fluid Check	61	DTC P0732 A/T 2ND GEAR FUNCTION	133
Stall Test	61	Description	133
Line Pressure Test.....	65	Wiring Diagram - AT - 2ND.....	136
		Diagnostic Procedure	137
		Component Inspection.....	138
		DTC P0733 A/T 3RD GEAR FUNCTION	139

GI

MA

EM

LC

EC

FE

AT

AX

SU

BR

ST

RS

BT

HA

SC

EL

IDX

CONTENTS (Cont'd)

Description	139	DTC VEHICLE SPEED SENSOR.MTR	205
Wiring Diagram - AT - 3RD.....	142	Description	205
Diagnostic Procedure	143	Wiring Diagram - AT - VSSMTR.....	207
Component Inspection.....	144	Diagnostic Procedure	208
DTC P0734 A/T 4TH GEAR FUNCTION	145	CONTROL UNIT (RAM), CONTROL UNIT (ROM)	209
Description	145	Description	209
Wiring Diagram - AT - 4TH.....	149	On Board Diagnosis Logic.....	209
Diagnostic Procedure	150	DTC Confirmation Procedure	209
Component Inspection.....	153	Diagnostic Procedure	210
DTC P0740 TORQUE CONVERTER CLUTCH		CONTROL UNIT (EEP ROM)	211
SOLENOID VALVE	154	Description	211
Description	154	On Board Diagnosis Logic.....	211
Wiring Diagram - AT - TCV.....	156	DTC Confirmation Procedure	211
Diagnostic Procedure	157	Diagnostic Procedure	212
Component Inspection.....	158	TROUBLE DIAGNOSES FOR SYMPTOMS	213
DTC P0744 A/T TCC S/V FUNCTION (LOCK-UP)	159	Wiring Diagram - AT - NONDTC	213
Description	159	1. O/D OFF Indicator Lamp Does Not Come On....	216
Wiring Diagram - AT - TCCSIG	161	2. Engine Cannot Be Started In P and N Position..	218
Diagnostic Procedure	162	3. In P Position, Vehicle Moves Forward or	
Component Inspection.....	166	Backward When Pushed	219
DTC P0745 LINE PRESSURE SOLENOID VALVE ...	167	4. In N Position, Vehicle Moves	220
Description	167	5. Large Shock. N -> R Position	222
Wiring Diagram - AT - LPSV.....	169	6. Vehicle Does Not Creep Backward In R	
Diagnostic Procedure	170	Position	224
Component Inspection.....	172	7. Vehicle Does Not Creep Forward in D, 2 or 1	
DTC P0750 SHIFT SOLENOID VALVE A	173	Position	228
Description	173	8. Vehicle Cannot Be Started From D ₁	231
Wiring Diagram - AT - SSV/A	175	9. A/T Does Not Shift: D ₁ -> D ₂ or Does Not	
Diagnostic Procedure	176	Kickdown: D ₄ -> D ₂	234
Component Inspection.....	178	10. A/T Does Not Shift: D ₂ -> D ₃	237
DTC P0755 SHIFT SOLENOID VALVE B	179	11. A/T Does Not Shift: D ₃ -> D ₄	240
Description	179	12. A/T Does Not Perform Lock-up	243
Wiring Diagram - AT - SSV/B	181	13. A/T Does Not Hold Lock-up Condition	245
Diagnostic Procedure	182	14. Lock-up Is Not Released.....	247
Component Inspection.....	184	15. Engine Speed Does Not Return To Idle (Light	
DTC P1705 THROTTLE POSITION SENSOR	185	Braking D ₄ -> D ₃).....	248
Description	185	16. Vehicle Does Not Start From D ₁	250
Wiring Diagram - AT - TPS.....	187	17. A/T Does Not Shift: D ₄ -> D ₃ , When	
Diagnostic Procedure	188	Overdrive Control Switch ON -> OFF	251
Component Inspection.....	191	18. A/T Does Not Shift: D ₃ -> 2 ₂ , When Selector	
DTC P1760 OVERRUN CLUTCH SOLENOID		Lever D -> 2 Position	252
VALVE	192	19. A/T Does Not Shift: 2 ₂ -> 1 ₁ , When Selector	
Description	192	Lever 2 -> 1 Position	253
Wiring Diagram - AT - OVRCSV.....	194	20. Vehicle Does Not Decelerate By Engine	
Diagnostic Procedure	195	Brake.....	254
Component Inspection.....	197	21. TCM Self-diagnosis Does Not Activate (PNP,	
DTC BATT/FLUID TEMP SEN (A/T FLUID TEMP		Overdrive Control and Throttle Position Switches	
SENSOR CIRCUIT AND TCM POWER SOURCE)	198	Circuit Checks)	254
Description	198	A/T SHIFT LOCK SYSTEM	263
Wiring Diagram - AT - BA/FTS	200	Description	263
Diagnostic Procedure	201	Wiring Diagram - SHIFT -.....	264
Component Inspection.....	204	Shift Lock System Electrical Parts Location.....	265

CONTENTS (Cont'd)

Removal.....	265	Band Servo Piston Assembly	341	GI
Diagnostic Procedure	266	Final Drive.....	346	
Installation and Adjustment.....	268	ASSEMBLY	350	MA
Component Check.....	269	Assembly (1).....	350	EM
ON-VEHICLE SERVICE	270	Adjustment (1)	350	EM
Control Valve Assembly and Accumulators	270	Assembly (2).....	355	
Revolution Sensor Replacement	271	Adjustment (2)	361	EM
Park/Neutral Position (PNP) Switch Adjustment	271	Assembly (3).....	363	
Control Cable Adjustment.....	272	SERVICE DATA AND SPECIFICATIONS (SDS)	370	LC
Differential Side Oil Seal Replacement.....	272	General Specifications.....	370	
REMOVAL AND INSTALLATION	273	Shift Schedule.....	370	EC
Removal.....	273	Stall Revolution.....	370	EC
Installation.....	274	Line Pressure.....	370	
OVERHAUL	276	Control Valves.....	371	FE
Components.....	276	Accumulator	371	FE
Oil Channel	279	Clutch and Brakes	372	
Locations of Adjusting Shims, Needle Bearings, Thrust Washers and Snap Rings	280	Final Drive.....	373	AT
DISASSEMBLY	281	Planetary Carrier and Oil Pump	374	
REPAIR FOR COMPONENT PARTS	295	Input Shaft	375	AX
Manual Shaft.....	295	Reduction Pinion Gear	375	AX
Oil Pump.....	298	Band Servo	376	
Control Valve Assembly.....	302	Output Shaft.....	376	SU
Control Valve Upper Body	310	Bearing Retainer.....	377	SU
Control Valve Lower Body	314	Total End Play.....	377	
Reverse Clutch	316	Reverse Clutch End Play	377	BR
High Clutch	319	Removal and Installation	378	BR
Forward and Overrun Clutches	324	Shift Solenoid Valves	378	
Low & Reverse Brake.....	329	Solenoid Valves	378	ST
Rear Internal Gear, Forward Clutch Hub and Overrun Clutch Hub.....	332	A/T Fluid Temperature Sensor.....	378	ST
Output Shaft, Idler Gear, Reduction Pinion Gear and Bearing Retainer.....	336	Revolution Sensor	378	RS
		Dropping Resistor	378	RS
				BT
				HA
				SC
				EL
				IDX

TROUBLE DIAGNOSIS — INDEX

Alphabetical & P No. Index for DTC

Alphabetical & P No. Index for DTC

NDAT0001

ALPHABETICAL INDEX FOR DTC

NDAT0001S01

Items (CONSULT-II screen terms)	DTC	Reference page
	CONSULT-II GST*1	
A/T 1ST GR FNCTN	P0731	AT-127
A/T 2ND GR FNCTN	P0732	AT-133
A/T 3RD GR FNCTN	P0733	AT-139
A/T 4TH GR FNCTN	P0734	AT-145
A/T TCC S/V FNCTN	P0744	AT-159
ATF TEMP SEN/CIRC	P0710	AT-110
ENGINE SPEED SIG	P0725	AT-123
L/PRESS SOL/CIRC	P0745	AT-167
O/R CLTCH SOL/CIRC	P1760	AT-192
PNP SW/CIRC	P0705	AT-103
SFT SOL A/CIRC*2	P0750	AT-173
SFT SOL B/CIRC*2	P0755	AT-179
TCC SOLENOID/CIRC	P0740	AT-154
TP SEN/CIRC A/T*2	P1705	AT-185
VEH SPD SEN/CIR AT*3	P0720	AT-117

*1: These numbers are prescribed by SAE J2012.

*2: When the fail-safe operation occurs, the MIL illuminates.

*3: The MIL illuminates when both the "Revolution sensor signal" and the "Vehicle speed sensor signal" meet the fail-safe condition at the same time.

TROUBLE DIAGNOSIS — INDEX

Alphabetical & P No. Index for DTC (Cont'd)

P NO. INDEX FOR DTC

=NDAT0001S02

DTC CONSULT-II GST*1	Items (CONSULT-II screen terms)	Reference page
P0705	PNP SW/CIRC	AT-103
P0710	ATF TEMP SEN/CIRC	AT-110
P0720	VEH SPD SEN/CIR AT*3	AT-117
P0725	ENGINE SPEED SIG	AT-123
P0731	A/T 1ST GR FNCTN	AT-127
P0732	A/T 2ND GR FNCTN	AT-133
P0733	A/T 3RD GR FNCTN	AT-139
P0734	A/T 4TH GR FNCTN	AT-145
P0740	TCC SOLENOID/CIRC	AT-154
P0744	A/T TCC S/V FNCTN	AT-159
P0745	L/PRESS SOL/CIRC	AT-167
P0750	SFT SOL A/CIRC*2	AT-173
P0755	SFT SOL B/CIRC*2	AT-179
P1705	TP SEN/CIRC A/T*2	AT-185
P1760	O/R CLTCH SOL/CIRC	AT-192

*1: These numbers are prescribed by SAE J2012.

*2: When the fail-safe operation occurs, the MIL illuminates.

*3: The MIL illuminates when both the "Revolution sensor signal" and the "Vehicle speed sensor signal" meet the fail-safe condition at the same time.

GI

MA

EM

LC

EC

FE

AT

AX

SU

BR

ST

RS

BT

HA

SC

EL

IDX

PRECAUTIONS

Precautions for Supplemental Restraint System (SRS) "AIR BAG" and "SEAT BELT PRE-TENSIONER"

Precautions for Supplemental Restraint System (SRS) "AIR BAG" and "SEAT BELT PRE-TENSIONER"

NDAT0002

The Supplemental Restraint System such as "AIR BAG" and "SEAT BELT PRE-TENSIONER" used along with a seat belt, helps to reduce the risk or severity of injury to the driver and front passenger for certain types of collision. The Supplemental Restraint System consists of driver air bag module (located in the center of the steering wheel), front passenger air bag module (located on the instrument panel on passenger side), seat belt pre-tensioners, a diagnosis sensor unit, warning lamp, wiring harness and spiral cable.

Information necessary to service the system safely is included in the **RS section** of this Service Manual.

WARNING:

- To avoid rendering the SRS inoperative, which could increase the risk of personal injury or death in the event of a collision which would result in air bag inflation, all maintenance should be performed by an authorized NISSAN dealer.
- Improper maintenance, including incorrect removal and installation of the SRS, can lead to personal injury caused by unintentional activation of the system. For removal of Spiral Cable and Air Bag Module, see the RS section.
- Do not use electrical test equipment on any circuit related to the SRS unless instructed to in this Service Manual. Spiral cable and wiring harnesses (except "SEAT BELT PRE-TENSIONER") covered with yellow insulation either just before the harness connectors or for the complete harness are related to the SRS.

Precautions for On Board Diagnostic (OBD) System of A/T and Engine

NDAT0003

The ECM has an on board diagnostic system. It will light up the malfunction indicator lamp (MIL) to warn the driver of a malfunction causing emission deterioration.

CAUTION:

- Be sure to turn the ignition switch OFF and disconnect the negative battery terminal before any repair or inspection work. The open/short circuit of related switches, sensors, solenoid valves, etc. will cause the MIL to light up.
- Be sure to connect and lock the connectors securely after work. A loose (unlocked) connector will cause the MIL to light up due to an open circuit. (Be sure the connector is free from water, grease, dirt, bent terminals, etc.)
- Be sure to route and secure the harnesses properly after work. Interference of the harness with a bracket, etc. may cause the MIL to light up due to a short circuit.
- Be sure to connect rubber tubes properly after work. A misconnected or disconnected rubber tube may cause the MIL to light up due to a malfunction of the fuel injection system, etc.
- Be sure to erase the unnecessary malfunction information (repairs completed) from the TCM or ECM before returning the vehicle to the customer.

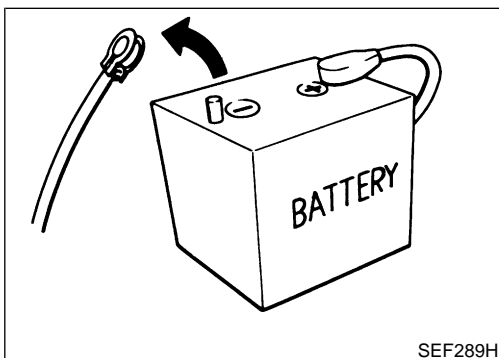

Precautions

NDAT0004

- Before connecting or disconnecting the TCM harness connector, turn ignition switch OFF and disconnect negative battery terminal. Failure to do so may damage the TCM. Because battery voltage is applied to TCM even if ignition switch is turned off.

PRECAUTIONS

Precautions (Cont'd)

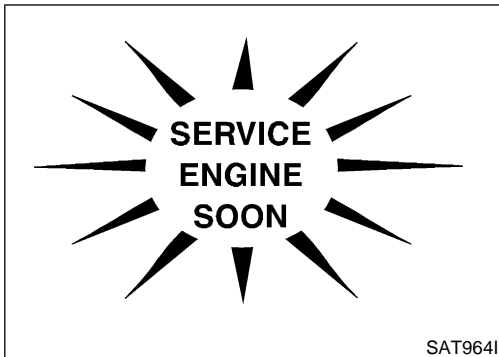
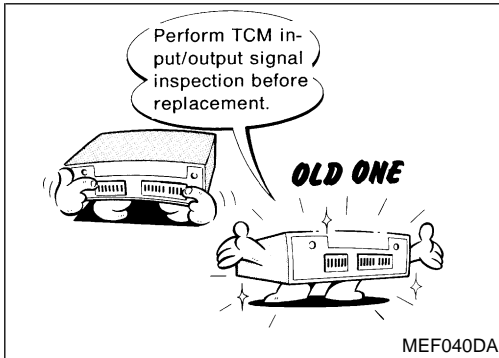
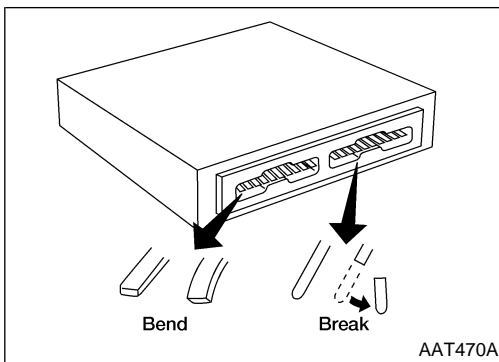

- When connecting or disconnecting pin connectors into or from TCM, take care not to damage pin terminals (bend or break).
Make sure that there are not any bends or breaks on TCM pin terminal, when connecting pin connectors.

- Before replacing TCM, perform TCM input/output signal inspection and make sure whether TCM functions properly or not. (See page AT-96.)

- After performing each TROUBLE DIAGNOSIS, perform "DTC (Diagnostic Trouble Code) CONFIRMATION PROCEDURE".
The DTC should not be displayed in the "DTC CONFIRMATION PROCEDURE" if the repair is completed.

- Before proceeding with disassembly, thoroughly clean the outside of the transaxle. It is important to prevent the internal parts from becoming contaminated by dirt or other foreign matter.
- Disassembly should be done in a clean work area.
- Use lint-free cloth or towels for wiping parts clean. Common shop rags can leave fibers that could interfere with the operation of the transaxle.
- Place disassembled parts in order for easier and proper assembly.
- All parts should be carefully cleaned with a general purpose, non-flammable solvent before inspection or reassembly.
- Gaskets, seals and O-rings should be replaced any time the transaxle is disassembled.
- It is very important to perform functional tests whenever they are indicated.
- The valve body contains precision parts and requires extreme care when parts are removed and serviced. Place disassembled valve body parts in order for easier and proper assembly. Care will also prevent springs and small parts from becoming scattered or lost.
- Properly installed valves, sleeves, plugs, etc. will slide along bores in valve body under their own weight.
- Before assembly, apply a coat of recommended ATF to all

GI

MA

EM

LC

EC

FE

AT

AX

SU

BR

ST

RS

BT

HA

SC

EL

IDX

PRECAUTIONS

Precautions (Cont'd)

parts. Apply petroleum jelly to protect O-rings and seals, or hold bearings and washers in place during assembly. Do not use grease.

- Extreme care should be taken to avoid damage to O-rings, seals and gaskets when assembling.
- Replace ATF cooler if excessive foreign material is found in oil pan or clogging strainer. Refer to “ATF COOLER SERVICE”, AT-9.
- After overhaul, refill the transaxle with new ATF.
- When the A/T drain plug is removed, only some of the fluid is drained. Old A/T fluid will remain in torque converter and ATF cooling system.

Always follow the procedures under “Changing A/T Fluid” in the MA section when changing A/T fluid.

Service Notice or Precautions

NDAT0005

FAIL-SAFE

NDAT0005S01

The TCM has an electronic Fail-Safe (limp home mode). This allows the vehicle to be driven even if a major electrical input/output device circuit is damaged.

Under Fail-Safe, the vehicle always runs in third gear, even with a shift lever position of 1, 2 or D. The customer may complain of sluggish or poor acceleration.

When the ignition key is turned ON following Fail-Safe operation, O/D OFF indicator lamp blinks for about 8 seconds. Refer to “TCM Self-diagnostic Procedure (No Tools)”, AT-48.

The blinking of the O/D OFF indicator lamp for about 8 seconds will appear only once and be cleared. The customer may resume normal driving conditions.

Always follow the “Work Flow”. Refer to “Work Flow”, AT-59.

The SELF-DIAGNOSIS results will be as follows:

The first SELF-DIAGNOSIS will indicate damage to the vehicle speed sensor or the revolution sensor.

During the next SELF-DIAGNOSIS, performed after checking the sensor, no damages will be indicated.

TORQUE CONVERTER SERVICE

NDAT0005S02

The torque converter should be replaced under any of the following conditions:

- External leaks in the hub weld area.
- Converter hub is scored or damaged.
- Converter pilot is broken, damaged or fits poorly into crankshaft.
- Steel particles are found after flushing the cooler and cooler lines.
- Pump is damaged or steel particles are found in the converter.
- Vehicle has TCC shudder and/or no TCC apply. Replace only after all hydraulic and electrical diagnoses have been made. (Converter clutch material may be glazed.)
- Converter is contaminated with engine coolant containing antifreeze.
- Internal failure of stator roller clutch.
- Heavy clutch debris due to overheating (blue converter).
- Steel particles or clutch lining material found in fluid filter or on magnet when no internal parts in unit are worn or damaged — indicates that lining material came from converter.

The torque converter should not be replaced if:

- The fluid has an odor, is discolored, and there is no evidence of metal or clutch facing particles.
- The threads in one or more of the converter bolt holes are damaged.
- Transaxle failure did not display evidence of damaged or worn internal parts, steel particles or clutch plate lining material in unit and inside the fluid filter.

PRECAUTIONS

Service Notice or Precautions (Cont'd)

- Vehicle has been exposed to high mileage (only). The exception may be where the torque converter clutch dampener plate lining has seen excess wear by vehicles operated in heavy and/or constant traffic, such as taxi, delivery or police use.

GI

ATF COOLER SERVICE

If A/T fluid contains frictional material (clutches, bands, etc.), replace radiator and flush cooler line using cleaning solvent and compressed air after repair of A/T. Refer to **LC-12**, "Radiator".

NDAT0005S03

MA

OBD-II SELF-DIAGNOSIS

- A/T self-diagnosis is performed by the TCM in combination with the ECM. The results can be read through the blinking pattern of the O/D OFF indicator or the malfunction indicator lamp (MIL). Refer to "SELF-DIAGNOSTIC RESULT TEST MODE", AT-40.

NDAT0005S04

EM

- The self-diagnostic results indicated by the MIL are automatically stored in both the ECM and TCM memories.

LC

Always perform the procedure "HOW TO ERASE DTC" on AT-37 to complete the repair and avoid unnecessary blinking of the MIL.

EC

- The following self-diagnostic items can be detected using ECM self-diagnostic results mode* only when the O/D OFF indicator lamp does not indicate any malfunctions.

FE

- park/neutral position (PNP) switch
- A/T 1st, 2nd, 3rd, or 4th gear function
- A/T TCC S/V function (lock-up).

*: For details of OBD-II, refer to **EC-63**, "ON BOARD DIAGNOSTIC SYSTEM DESCRIPTION".

AT

- Certain systems and components, especially those related to OBD, may use a new style slide-locking type harness connector.

AX

For description and how to disconnect, refer to **EL-5**, "Description".

Wiring Diagrams and Trouble Diagnosis

NDAT0006

SU

When you read wiring diagrams, refer to the following:

- Refer to **GI-10**, "HOW TO READ WIRING DIAGRAMS".
- Refer to **EL-10**, "POWER SUPPLY ROUTING" for power distribution circuit.

BR

When you perform trouble diagnosis, refer to the following:

- Refer to **GI-33**, "How to Follow Test Groups in Trouble Diagnoses".
- Refer to **GI-22**, "HOW TO PERFORM EFFICIENT DIAGNOSIS FOR AN ELECTRICAL INCIDENT".

ST

RS

BT

HA

SC

EL

IDX

PREPARATION

Special Service Tools

Special Service Tools

NDAT0007

The actual shapes of Kent-Moore tools may differ from those of special service tools illustrated here.

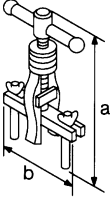
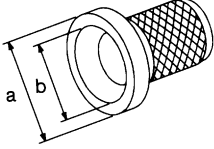
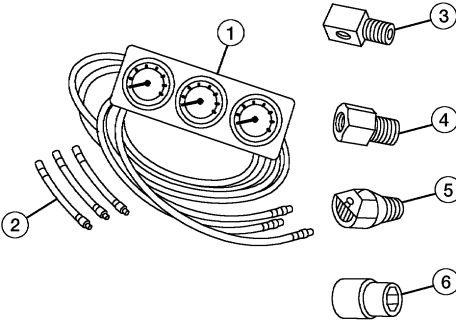
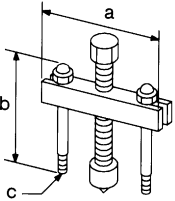
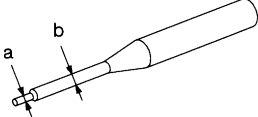
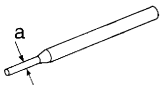
Tool number (Kent-Moore No.) Tool name	Description	
KV381054S0 (J34286) Puller		<ul style="list-style-type: none"> ● Removing differential side oil seals ● Removing differential side bearing outer race ● Removing idler gear bearing outer race <p>a: 250 mm (9.84 in) b: 160 mm (6.30 in)</p>
ST33400001 (J26082) Drift		<ul style="list-style-type: none"> ● Installing differential side oil seal (RH side) ● Installing oil seal on oil pump housing <p>a: 60 mm (2.36 in) dia. b: 47 mm (1.85 in) dia.</p>
(J34301-C) Oil pressure gauge set 1 (J34301-1) Oil pressure gauge 2 (J34301-2) Hoses 3 (J34298) Adapter 4 (J34282-2) Adapter 5 (790-301-1230-A) 60° Adapter 6 (J34301-15) Square socket		<ul style="list-style-type: none"> ● Measuring line pressure
ST27180001 (J25726-A) Puller		<p>Removing idler gear</p> <p>a: 100 mm (3.94 in) b: 110 mm (4.33 in) c: M8 x 1.25P</p>
ST23540000 (J25689-A) Pin punch		<ul style="list-style-type: none"> ● Removing and installing parking rod plate and manual plate pins <p>a: 2.3 mm (0.091 in) dia. b: 4 mm (0.16 in) dia.</p>
ST25710000 (J25689-A) Pin punch		<ul style="list-style-type: none"> ● Aligning groove of manual shaft and hole of transmission case <p>a: 2 mm (0.08 in) dia.</p>

PREPARATION

Special Service Tools (Cont'd)

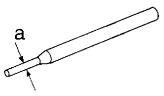
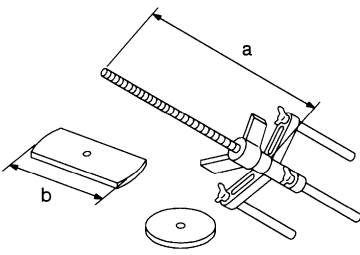
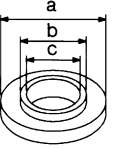
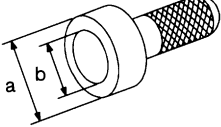
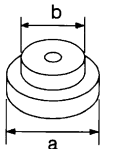
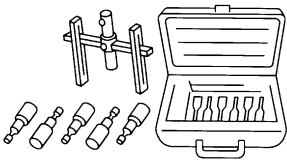
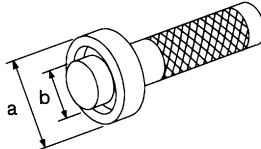
Tool number (Kent-Moore No.) Tool name	Description		
KV32101000 (J25689-A) Pin punch	 <p>NT410</p>	<ul style="list-style-type: none"> ● Installing manual shaft retaining pin a: 4 mm (0.16 in) dia. 	GI MA EM
KV31102400 (J34285 and J34285-87) Clutch spring compressor	 <p>NT423</p>	<ul style="list-style-type: none"> ● Removing and installing clutch return springs ● Installing low and reverse brake piston a: 320 mm (12.60 in) b: 174 mm (6.85 in) 	LC EC FE
KV40100630 (J26092) Drift	 <p>NT107</p>	<ul style="list-style-type: none"> ● Installing reduction gear bearing inner race ● Installing idler gear bearing inner race a: 67.5 mm (2.657 in) dia. b: 44 mm (1.73 in) dia. c: 38.5 mm (1.516 in) dia. 	AT AX SU
ST30720000 (J25405 and J34331) Bearing installer	 <p>NT115</p>	<ul style="list-style-type: none"> ● Installing idler gear bearing outer race a: 77 mm (3.03 in) dia. b: 55.5 mm (2.185 in) dia. 	BR ST
ST35321000 () Drift	 <p>NT073</p>	<ul style="list-style-type: none"> ● Installing output shaft bearing a: 49 mm (1.93 in) dia. b: 41 mm (1.61 in) dia. 	RS BT HA
(J34291-A) Shim setting gauge set	 <p>NT101</p>	<ul style="list-style-type: none"> ● Selecting oil pump cover bearing race and oil pump thrust washer ● Selecting side gear thrust washer 	SC EL
ST33230000 (J25805-01) Drift	 <p>NT084</p>	<ul style="list-style-type: none"> ● Installing differential side bearing a: 51 mm (2.01 in) dia. b: 28.5 mm (1.122 in) dia. 	IDX

PREPARATION

Special Service Tools (Cont'd)

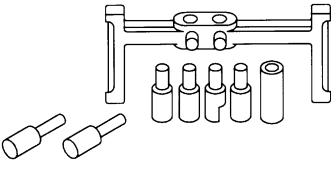
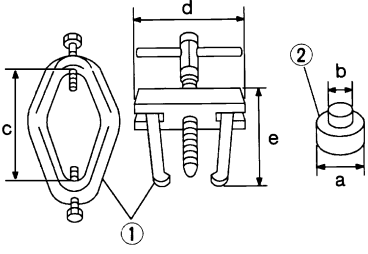
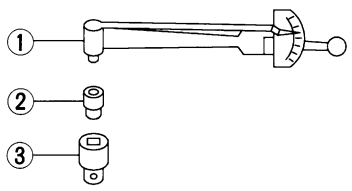
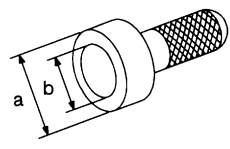
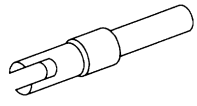
Tool number (Kent-Moore No.) Tool name	Description
(J34290) Shim selecting tool set	 <ul style="list-style-type: none"> ● Selecting differential side bearing adjusting shim <p style="text-align: center;">NT080</p>
ST3306S001 (J22888-D) Differential side bearing puller set 1 ST33051001 (J22888-D) Puller 2 ST33061000 (J8107-2) Adapter	 <ul style="list-style-type: none"> ● Removing differential side bearing inner race <p> a: 38 mm (1.50 in) dia. b: 28.5 mm (1.122 in) dia. c: 130 mm (5.12 in) d: 135 mm (5.31 in) e: 100 mm (3.94 in) </p> <p style="text-align: center;">AMT153</p>
ST3127S000 (J25765-A) Preload gauge 1 GG91030000 (J25765-A) Torque wrench 2 HT62940000 (—) Socket adapter 3 HT62900000 (—) Socket adapter	 <ul style="list-style-type: none"> ● Checking differential side bearing preload <p style="text-align: center;">NT124</p>
ST35271000 (J26091) Drift	 <ul style="list-style-type: none"> ● Installing idler gear <p> a: 72 mm (2.83 in) dia. b: 63 mm (2.48 in) dia. </p> <p style="text-align: center;">NT115</p>
(J39713) Preload adapter	 <ul style="list-style-type: none"> ● Selecting differential side bearing adjusting shim ● Checking differential side bearing preload <p style="text-align: center;">NT087</p>

Commercial Service Tools

NDAT0008

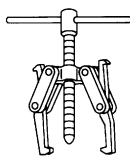
Tool name	Description
Puller	 <ul style="list-style-type: none"> ● Removing idler gear bearing inner race ● Removing and installing band servo piston snap ring <p style="text-align: center;">NT077</p>

PREPARATION

Commercial Service Tools (Cont'd)

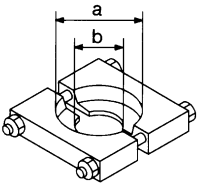
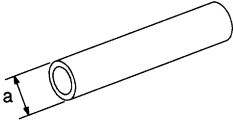
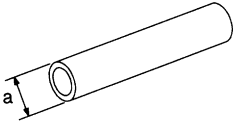
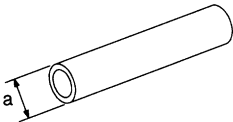
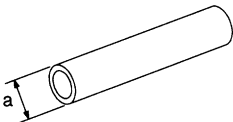
Tool name	Description	
Puller	 <p>● Removing reduction gear bearing inner race a: 60 mm (2.36 in) dia. b: 35 mm (1.38 in) dia.</p> <p>NT411</p>	GI MA EM
Drift	 <p>● Installing differential side oil seal (Left side) a: 90 mm (3.54 in) dia.</p> <p>NT083</p>	LC EC
Drift	 <p>● Installing needle bearing on bearing retainer a: 36 mm (1.42 in) dia.</p> <p>NT083</p>	FE AT
Drift	 <p>● Removing needle bearing from bearing retainer a: 33.5 mm (1.319 in) dia.</p> <p>NT083</p>	AX SU
Drift	 <p>● Installing differential side bearing outer race a: 75 mm (2.95 in) dia.</p> <p>NT083</p>	BR ST

RS

BT

HA

SC

EL

IDX

OVERALL SYSTEM

A/T Electrical Parts Location

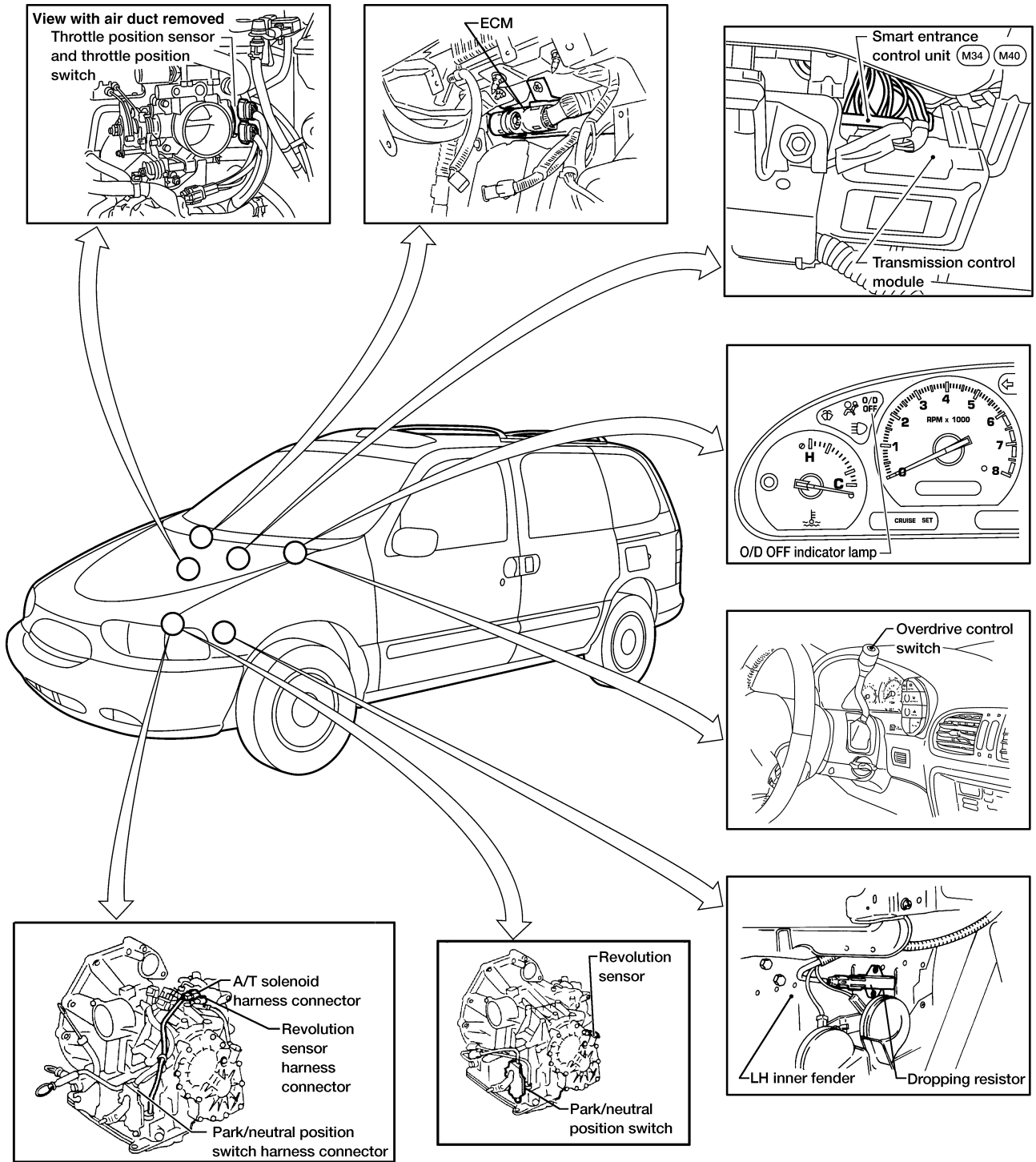

OVERALL SYSTEM

Circuit Diagram

Circuit Diagram

NDAT0010

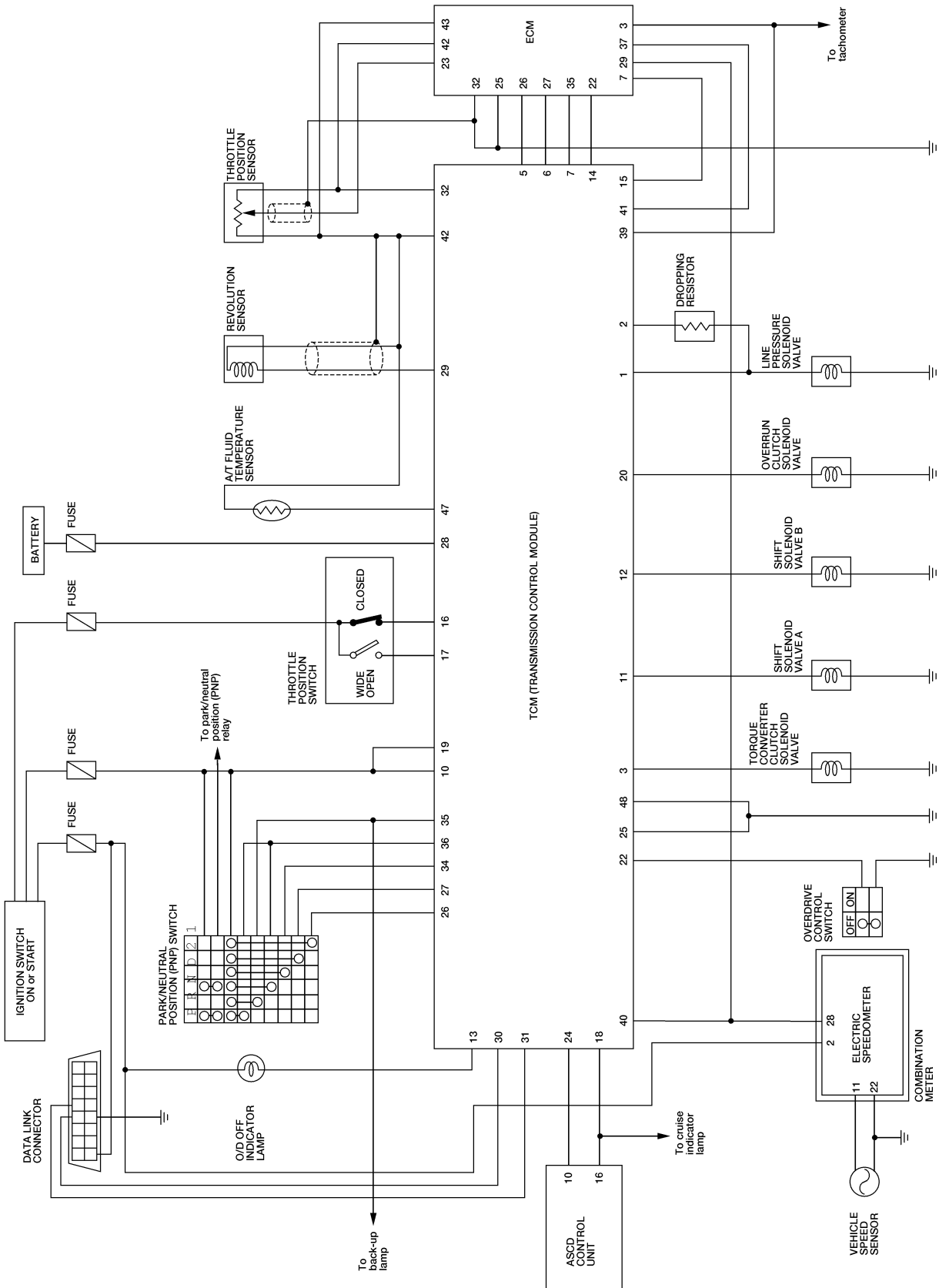

GI

MA

EM

LC

EC

FE

AT

AX

SU

BR

ST

RS

BT

HA

SC

EL

IDX

WAT321

OVERALL SYSTEM

Cross-sectional View

Cross-sectional View

NDAT0012

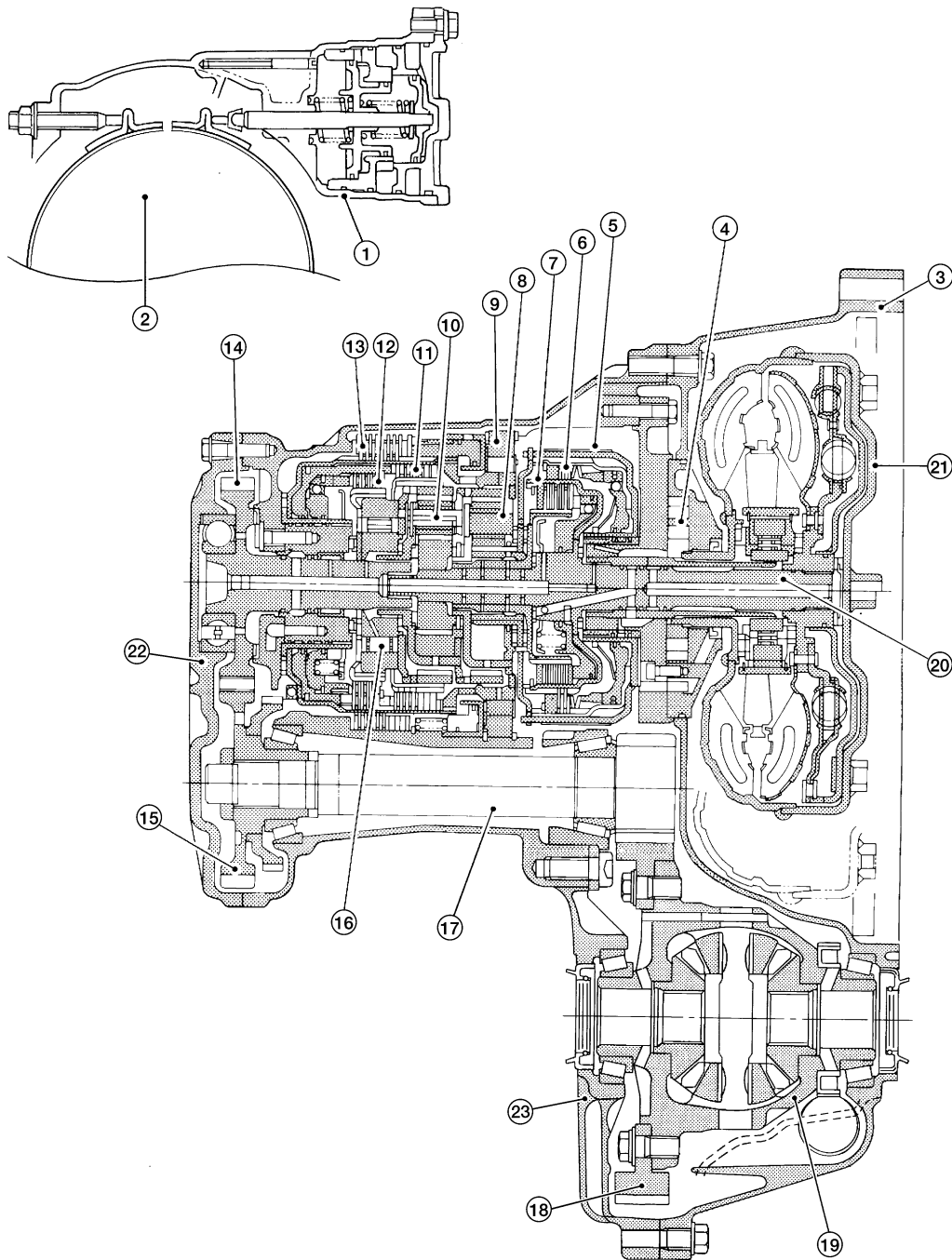

LAT382

- | | | |
|-------------------------|----------------------------|---------------------------|
| 1. Band servo piston | 9. Low one-way clutch | 17. Pinion reduction gear |
| 2. Reverse clutch drum | 10. Rear planetary gear | 18. Final gear |
| 3. Converter housing | 11. Forward clutch | 19. Differential case |
| 4. Oil pump | 12. Overrun clutch | 20. Input shaft |
| 5. Brake band | 13. Low & reverse brake | 21. Torque converter |
| 6. Reverse clutch | 14. Output gear | 22. Side cover |
| 7. High clutch | 15. Idler gear | 23. Transmission case |
| 8. Front planetary gear | 16. Forward one-way clutch | |

OVERALL SYSTEM

Hydraulic Control Circuit

Hydraulic Control Circuit

NDAT0013

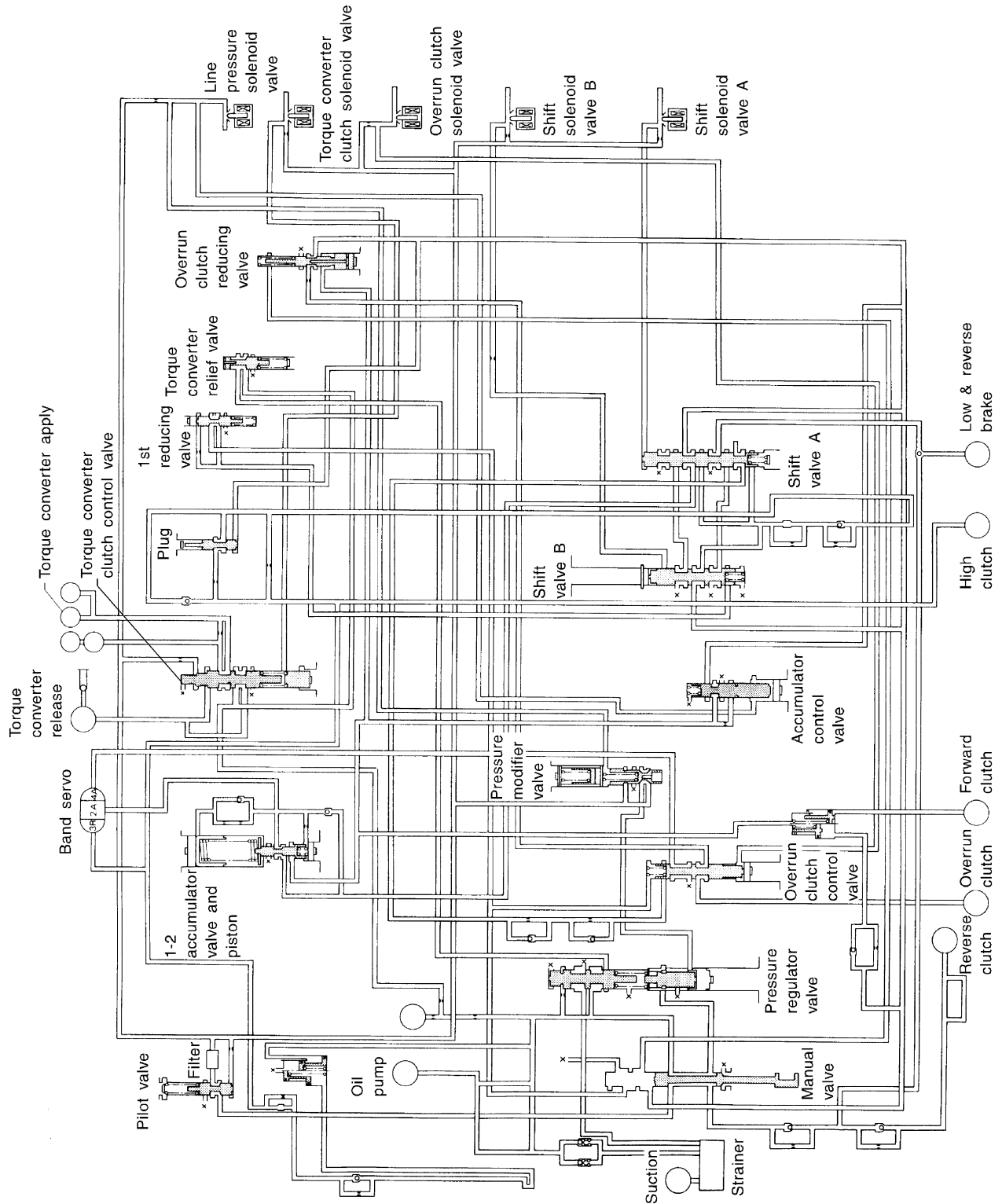

- GI
- MA
- EM
- LC
- EC
- FE
- AT**
- AX
- SU
- BR
- ST
- RS
- BT
- HA
- SC
- EL
- IDX

AAT549A

OVERALL SYSTEM

Shift Mechanism

Shift Mechanism

NDAT0014

NDAT0014S01

CONSTRUCTION

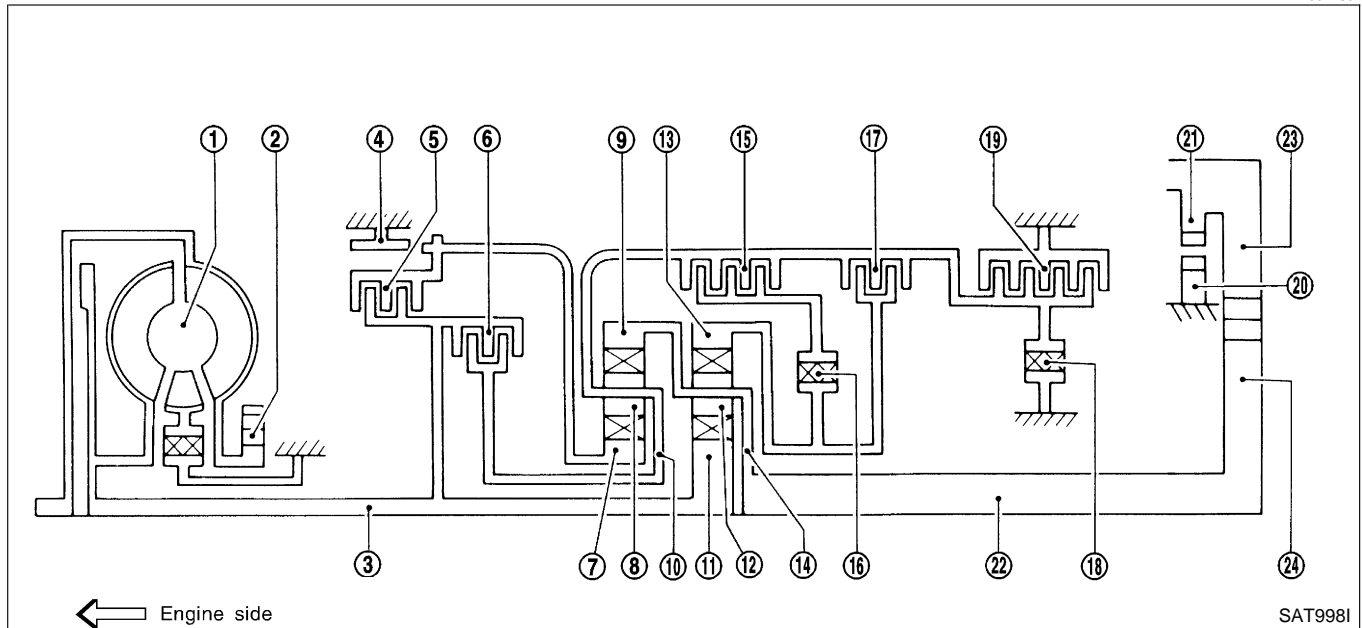

SAT998I

- | | | |
|----------------------|-----------------------------|-------------------------|
| 1. Torque converter | 9. Front internal gear | 17. Overrun clutch |
| 2. Oil pump | 10. Front planetary carrier | 18. Low one-way clutch |
| 3. Input shaft | 11. Rear sun gear | 19. Low & reverse brake |
| 4. Brake band | 12. Rear pinion gear | 20. Parking pawl |
| 5. Reverse clutch | 13. Rear internal gear | 21. Parking gear |
| 6. High clutch | 14. Rear planetary carrier | 22. Output shaft |
| 7. Front sun gear | 15. Forward clutch | 23. Idle gear |
| 8. Front pinion gear | 16. Forward one-way clutch | 24. Output gear |

OVERALL SYSTEM

Shift Mechanism (Cont'd)

FUNCTION OF CLUTCH AND BRAKE

=NDAT0014S03

Clutch and brake components	Abbr.	Function
Reverse clutch 5	R/C	To transmit input power to front sun gear 7 .
High clutch 6	H/C	To transmit input power to front planetary carrier 10 .
Forward clutch 15	F/C	To connect front planetary carrier 10 with forward one-way clutch 16 .
Overrun clutch 17	O/C	To connect front planetary carrier 10 with rear internal gear 13 .
Brake band 4	B/B	To lock front sun gear 7 .
Forward one-way clutch 16	F/O.C	When forward clutch 15 is engaged, to stop rear internal gear 13 from rotating in opposite direction against engine revolution.
Low one-way clutch 18	L/O.C	To stop front planetary carrier 10 from rotating in opposite direction against engine revolution.
Low & reverse brake 19	L & R/B	To lock front planetary carrier 10 .

CLUTCH AND BAND CHART

NDAT0014S04

Shift position	Reverse clutch 5	High clutch 6	Forward clutch 15	Overrun clutch 17	Band servo			Forward one-way clutch 16	Low one-way clutch 18	Low & reverse brake 19	Lock-up	Remarks
					2nd apply	3rd release	4th apply					
P												PARK POSITION
R	○									○		REVERSE POSITION
N												NEUTRAL POSITION
D*4	1st		○	*1D				B	B			Automatic shift 1 ↔ 2 ↔ 3 ↔ 4
	2nd		○	*1 A	○			B				
	3rd		○	○	*1 A	*2C	C	B		*5○		
	4th		○	C		*3C	C	○		○		
2	1st		○	D				B	B			Automatic shift 1 ↔ 2
	2nd		○	A	○			B				
1	1st		○	○				B		○		Locks (held stationary) in 1st speed 1 ↔ 2
	2nd		○	○	○			B				

*1: Operates when overdrive control switch is set in OFF position.

*2: Oil pressure is applied to both 2nd "apply" side and 3rd "release" side of band servo piston. However, brake band does not contract because oil pressure area on the "release" side is greater than that on the "apply" side.

*3: Oil pressure is applied to 4th "apply" side in condition *2 above, and brake band contracts.

*4: A/T will not shift to 4th when overdrive control switch is set in OFF position.

*5: Operates when overdrive control switch is OFF.

○: Operates

A: Operates when throttle opening is less than 3/16, activating engine brake.

B: Operates during "progressive" acceleration.

C: Operates but does not affect power transmission.

D: Operates when throttle opening is less than 3/16, but does not affect engine brake.

OVERALL SYSTEM

Shift Mechanism (Cont'd)

POWER TRANSMISSION

=NDAT0014S02

P and N Positions

NDAT0014S0201

- P position
Similar to the N position, the clutches do not operate. The parking pawl engages with the parking gear to mechanically hold the output shaft so that the power train is locked.
- N position
Power from the input shaft is not transmitted to the output shaft because the clutches do not operate.

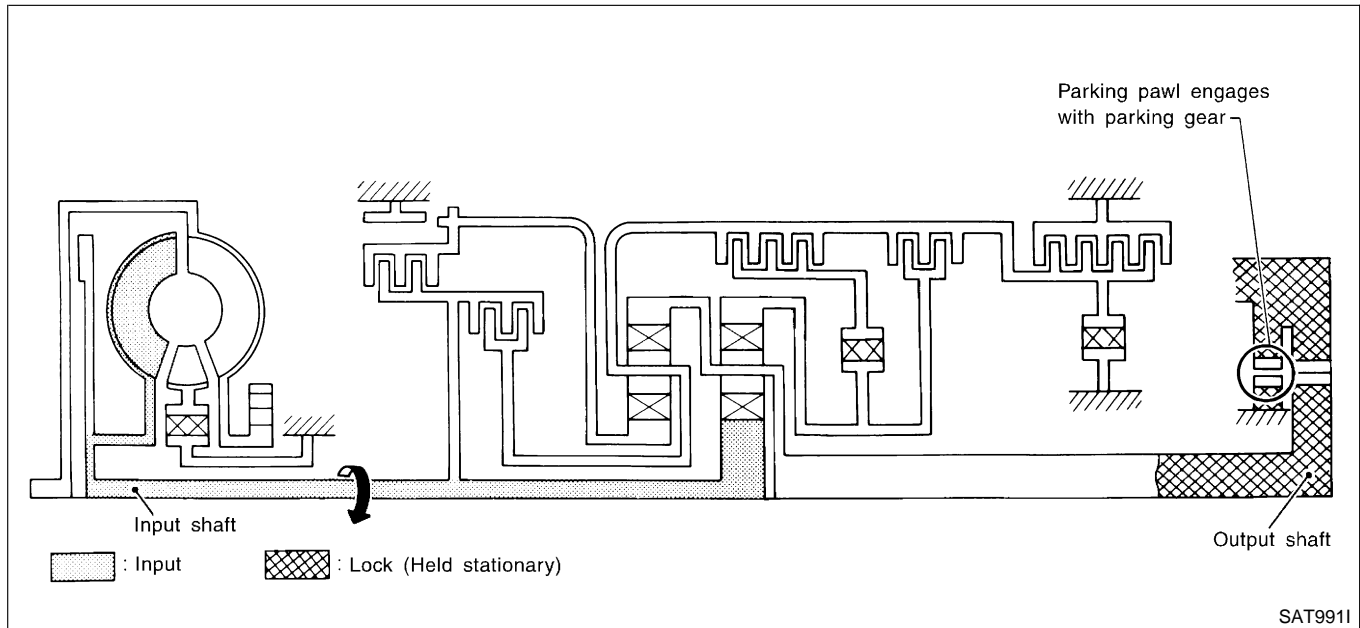

OVERALL SYSTEM

Shift Mechanism (Cont'd)

1₁ Position

-NDAT0014S0202

<ul style="list-style-type: none"> ● Forward clutch ● Forward one-way clutch ● Overrun clutch ● Low and reverse brake 	<p>As overrun clutch engages, rear internal gear is locked by the operation of low and reverse brake. This is different from that of D₁ and 2₁.</p>
<p>Engine brake</p>	<p>Overrun clutch always engages, therefore engine brake can be obtained when decelerating.</p>

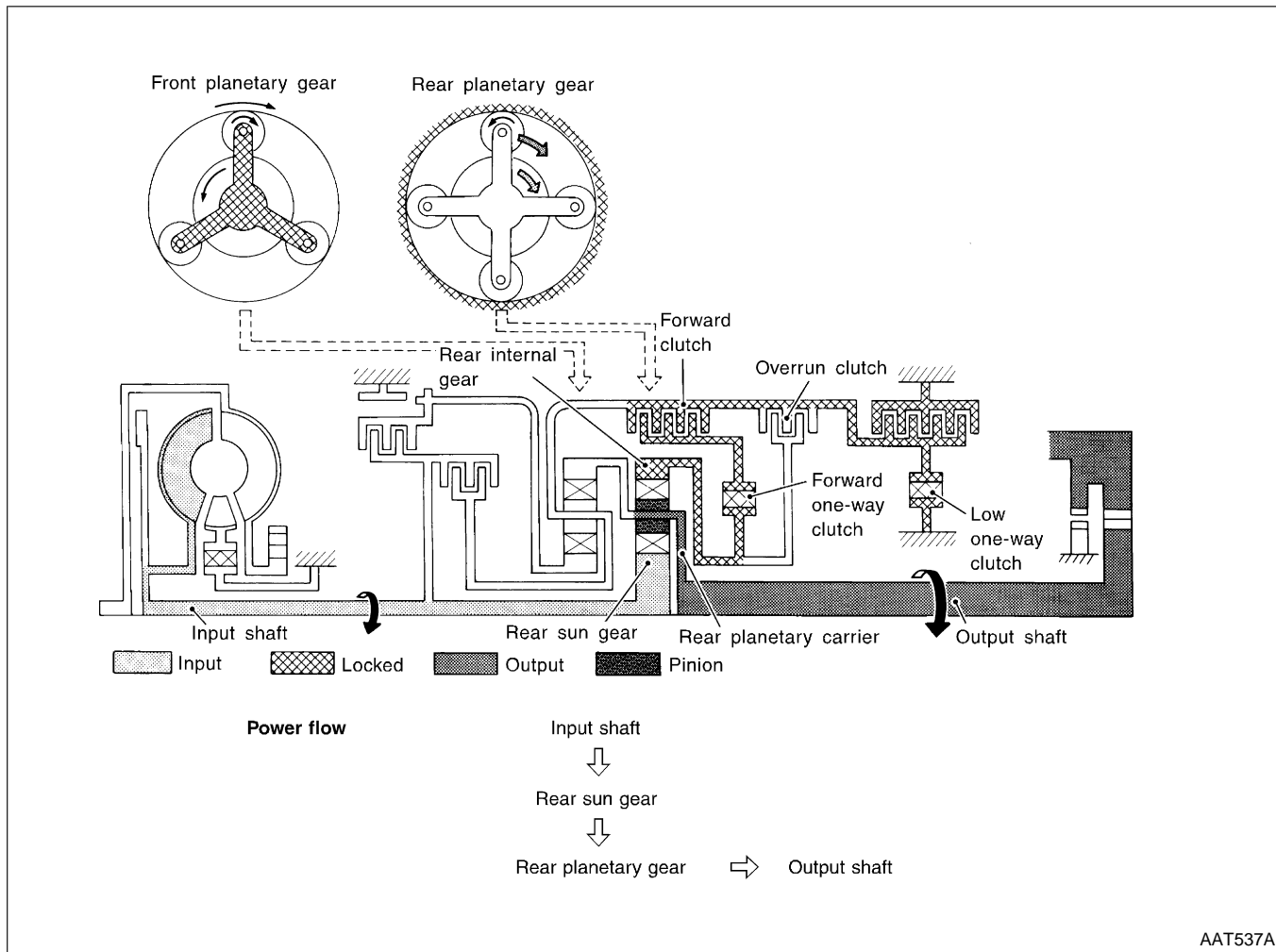

AAT537A

GI
MA
EM
LC
EC
FE
AT
AX
SU
BR
ST
RS
BT
HA
SC
EL
IDX

OVERALL SYSTEM

Shift Mechanism (Cont'd)

D₁ and 2₁ Positions

=NDAT0014S0203

<ul style="list-style-type: none"> ● Forward one-way clutch ● Forward clutch ● Low one-way clutch 	Rear internal gear is locked to rotate counterclockwise because of the functioning of these three clutches.
Overrun clutch engagement conditions (Engine brake)	D ₁ : Overdrive control switch OFF and throttle opening is less than 3/16 2 ₁ : Always engaged At D ₁ and 2 ₁ positions, engine brake is not activated due to free turning of low one-way clutch.

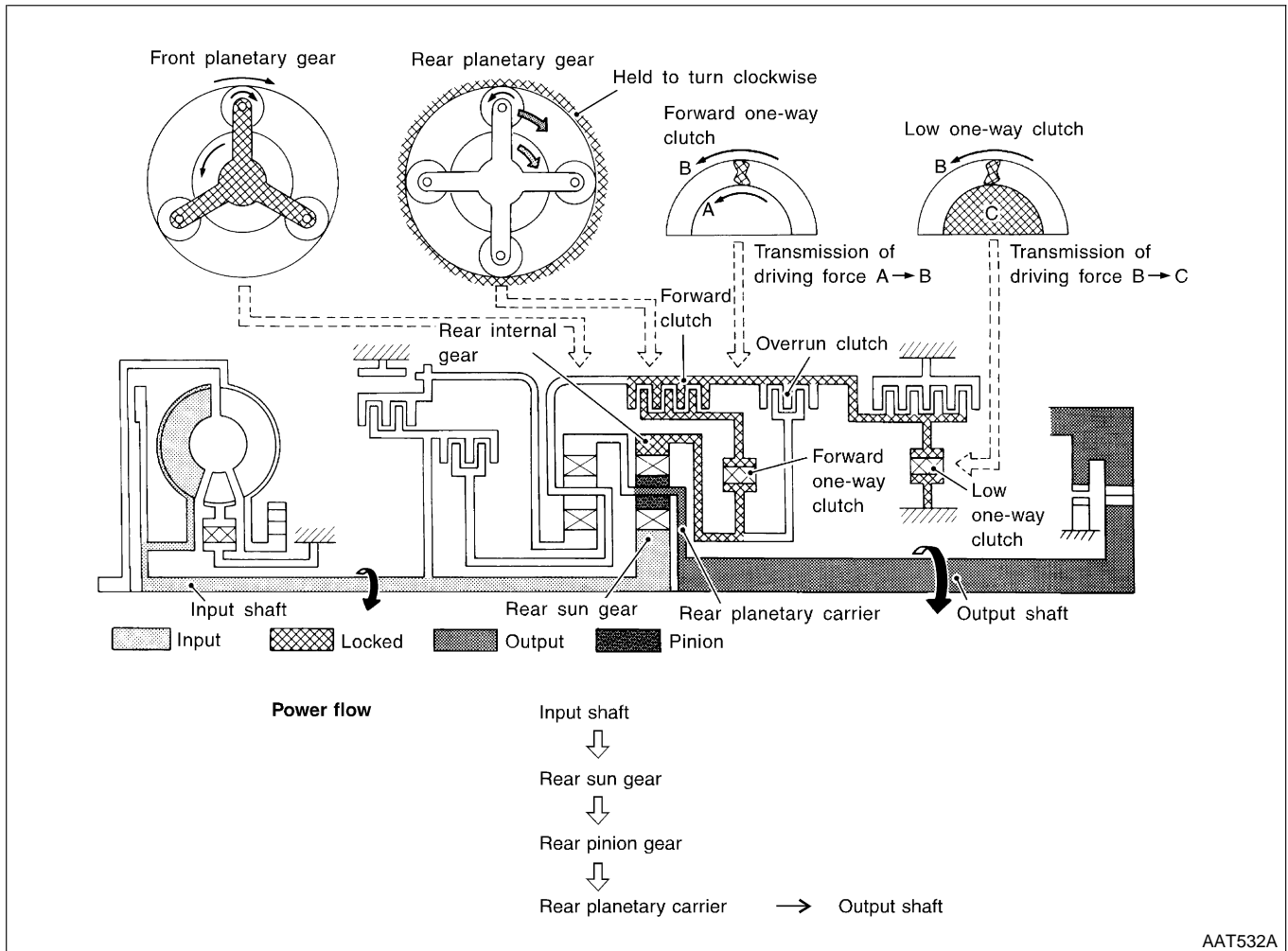

AAT532A

OVERALL SYSTEM

Shift Mechanism (Cont'd)

D₂, 2₂ and 1₂ Positions

=NDAT0014S0204

<ul style="list-style-type: none"> • Forward clutch • Forward one-way clutch • Brake band 	<p>Rear sun gear drives rear planetary carrier and combined front internal gear. Front internal gear now rotates around front sun gear accompanying front planetary carrier. As front planetary carrier transfers the power to rear internal gear through forward clutch and forward one-way clutch, this rotation of rear internal gear increases the speed of rear planetary carrier compared with that of the 1st speed.</p>
<p>Overrun clutch engagement conditions</p>	<p>D₂: Overdrive control switch OFF and throttle opening is less than 3/16 2₂ and 1₂: Always engaged</p>

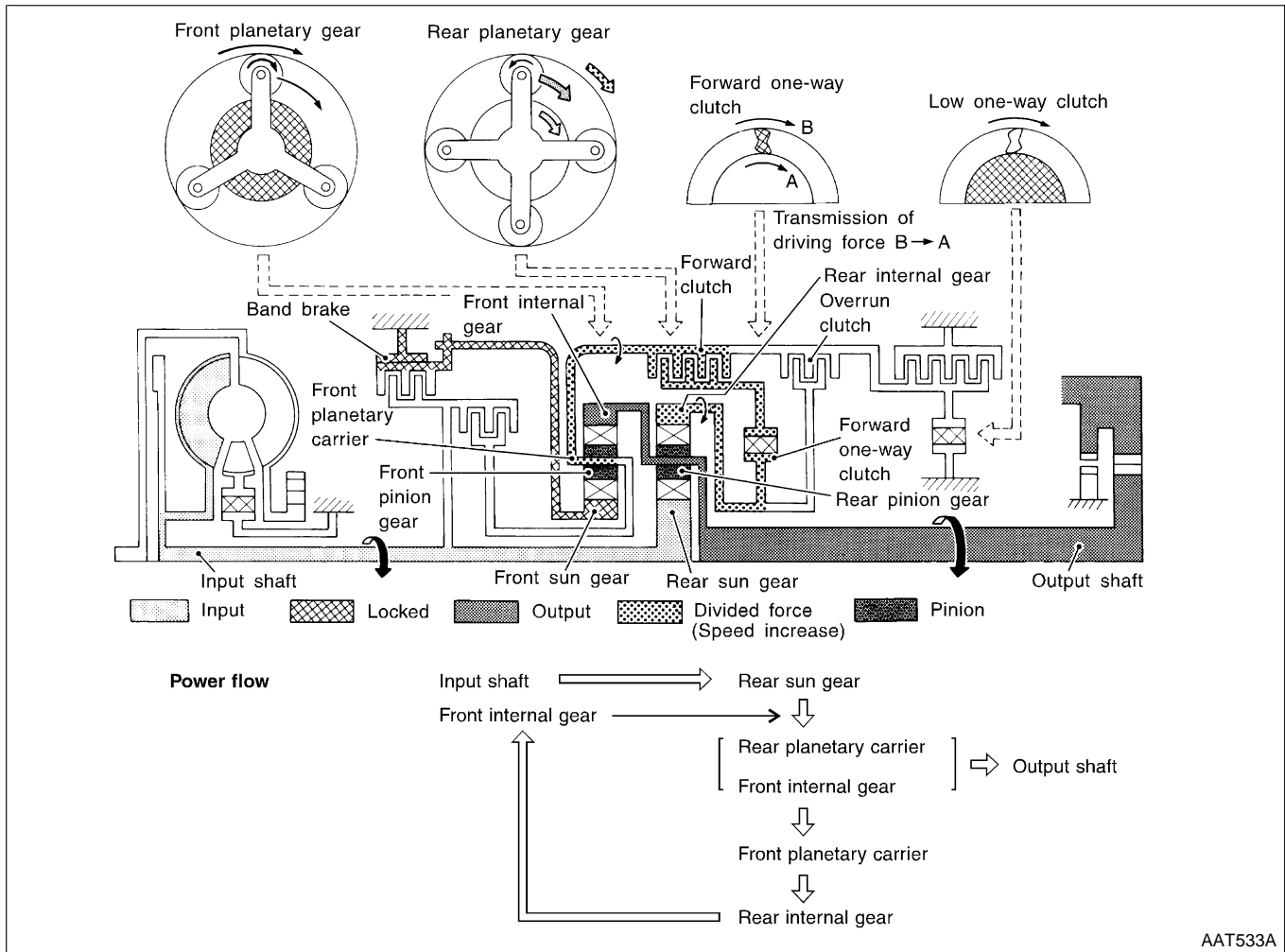

AAT533A

GI
MA
EM
LC
EC
FE
AT
AX
SU
BR
ST
RS
BT
HA
SC
EL
IDX

OVERALL SYSTEM

Shift Mechanism (Cont'd)

D₃ Position

=NDAT0014S0205

<ul style="list-style-type: none"> ● High clutch ● Forward clutch ● Forward one-way clutch 	<p>Input power is transmitted to front planetary carrier through high clutch. And front planetary carrier is connected to rear internal gear by operation of forward clutch and forward one-way clutch. This rear internal gear rotation and another input (the rear sun gear) accompany rear planetary carrier to turn at the same speed.</p>
<p>Overrun clutch engagement conditions</p>	<p>D₃: Overdrive control switch "OFF" and throttle opening is less than 3/16</p>

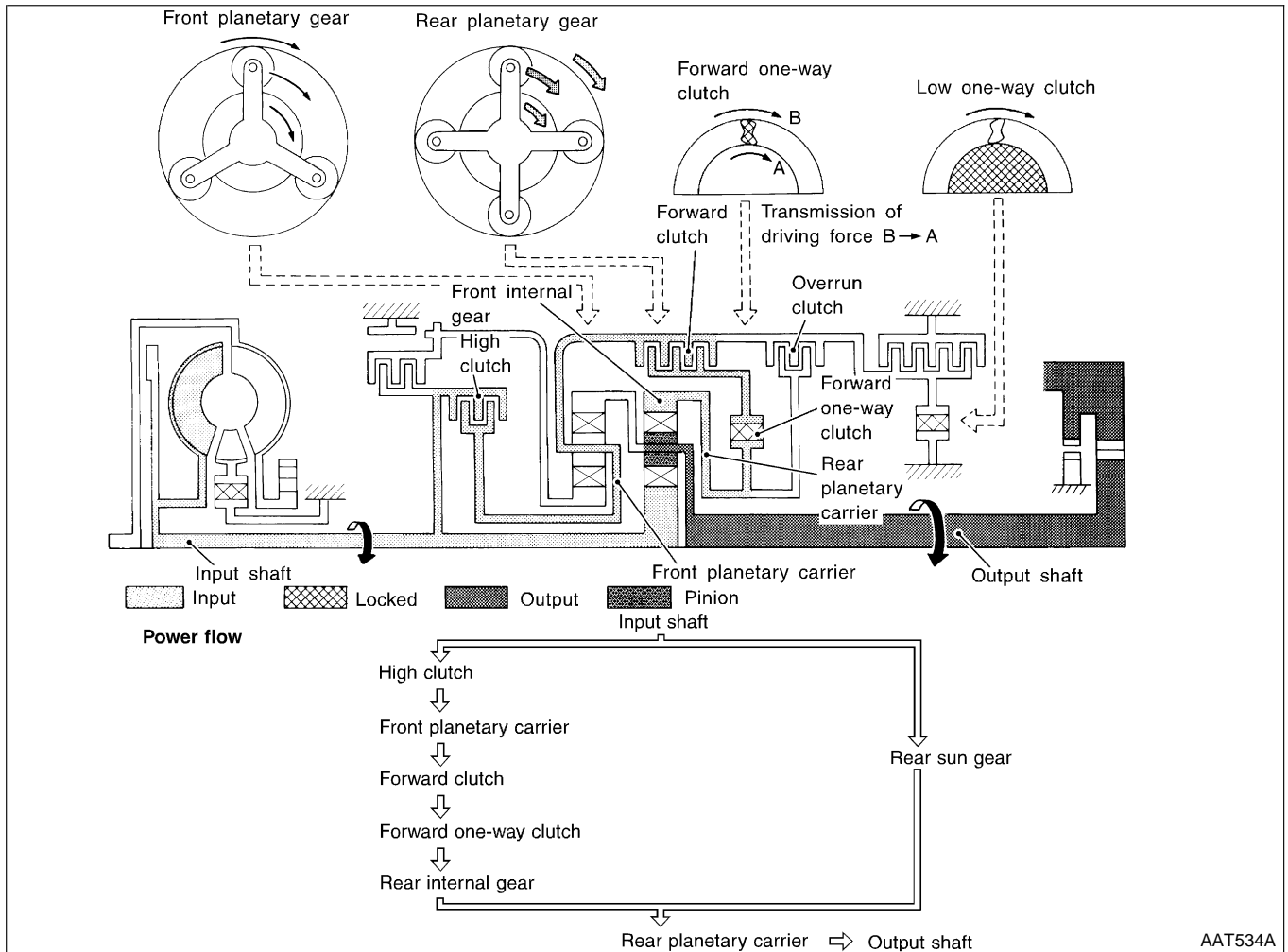

OVERALL SYSTEM

Shift Mechanism (Cont'd)

D₄ (O/D) Position

=NDAT0014S0206

<ul style="list-style-type: none"> ● High clutch ● Brake band ● Forward clutch (Does not affect power transmission) 	<p>Input power is transmitted to front carrier through high clutch. This front carrier turns around the sun gear which is fixed by brake band and makes front internal gear (output) turn faster.</p>
<p>Engine brake</p>	<p>At D₄ position, there is no one-way clutch in the power transmission line and engine brake can be obtained when decelerating.</p>

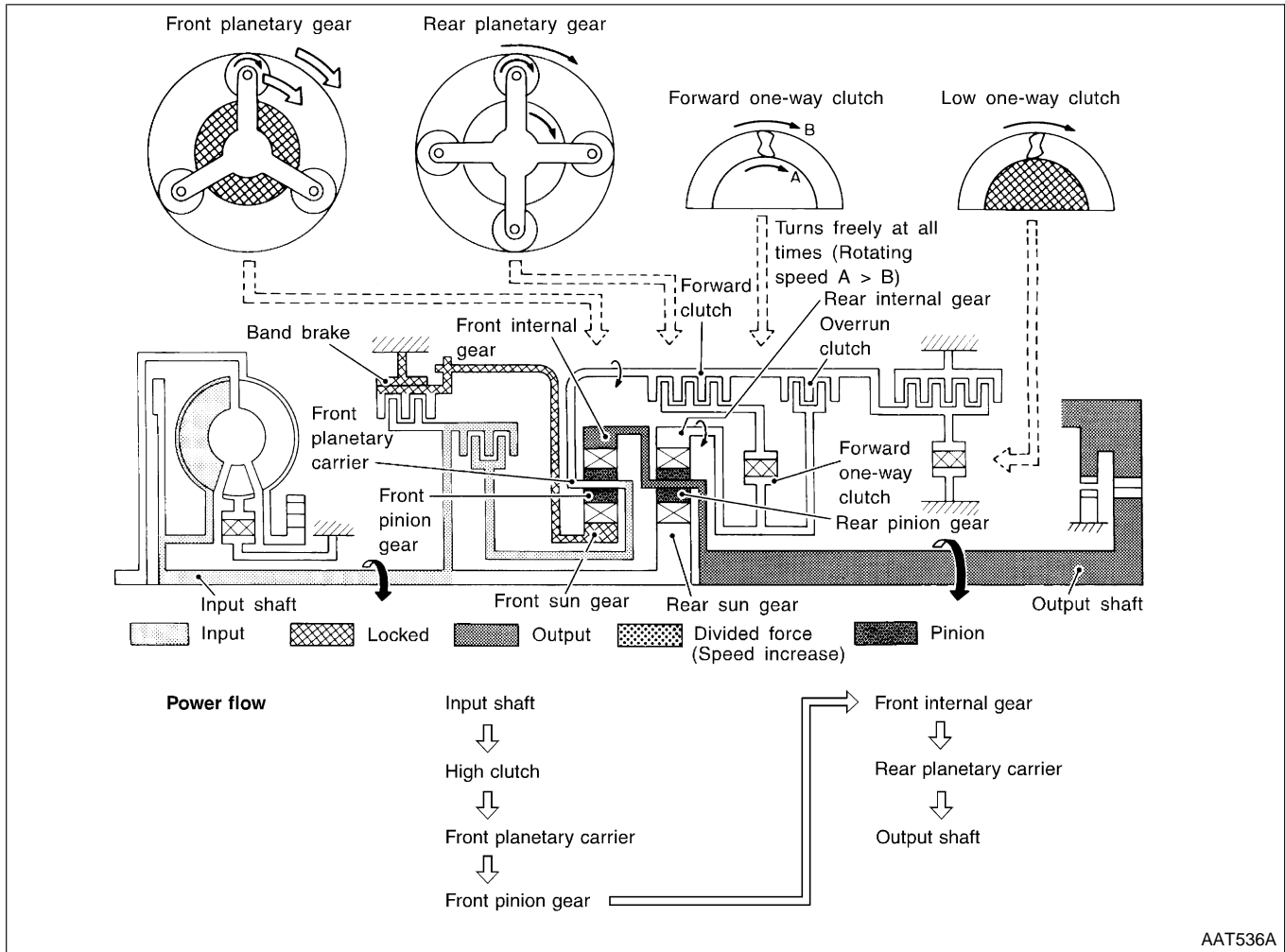

AAT536A

OVERALL SYSTEM

Shift Mechanism (Cont'd)

R Position

=NDAT0014S0207

<ul style="list-style-type: none"> ● Reverse clutch ● Low and reverse brake 	<p>Front planetary carrier is stationary because of the operation of low and reverse brake. Input power is transmitted to front sun gear through reverse clutch, which drives front internal gear in the opposite direction.</p>
<p>Engine brake</p>	<p>As there is no one-way clutch in the power transmission line, engine brake can be obtained when decelerating.</p>

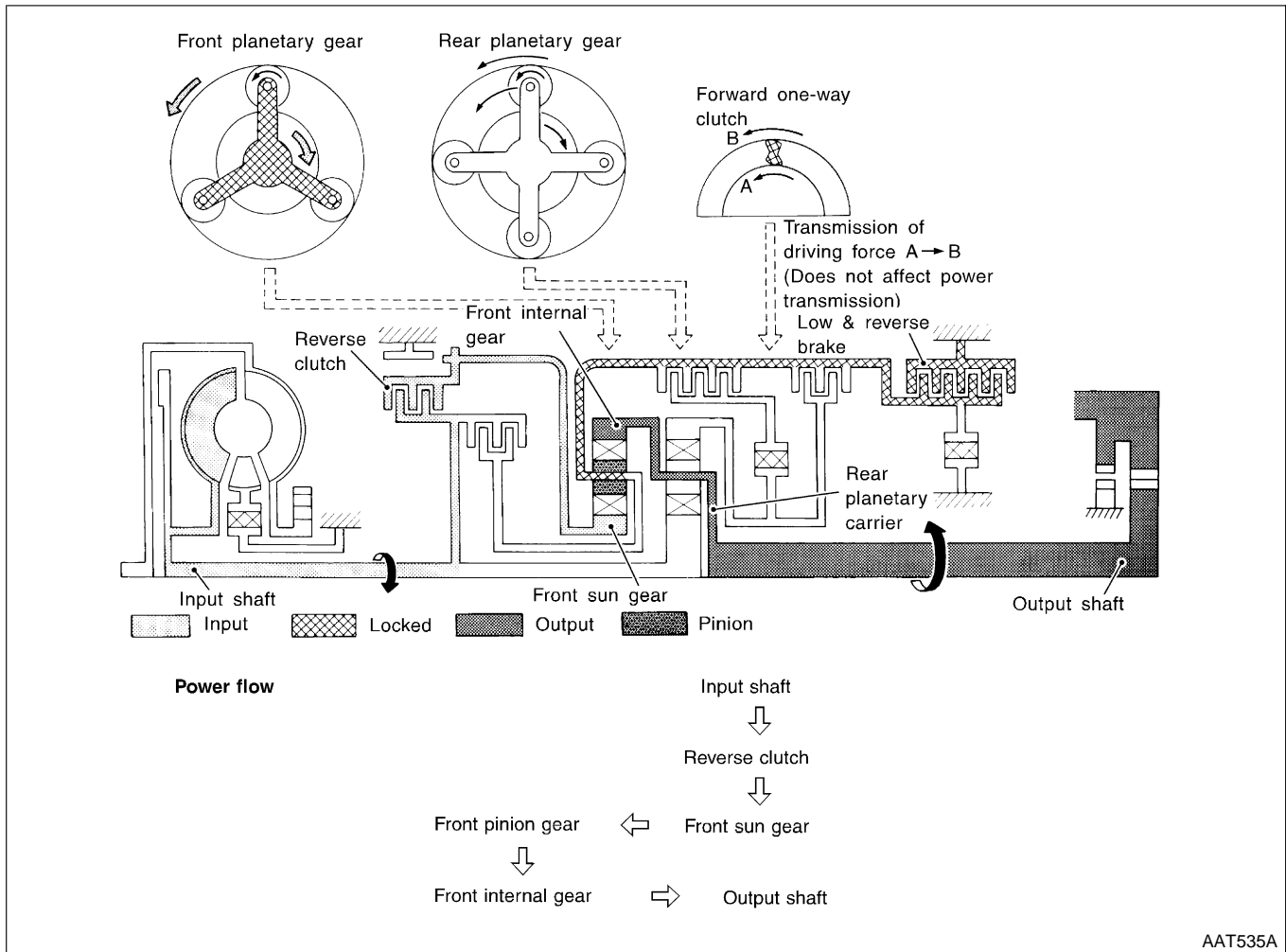

AAT535A

OVERALL SYSTEM

Control System

Control System

=NDAT0015

NDAT0015S01

OUTLINE

The automatic transaxle senses vehicle operating conditions through various sensors. It always controls the optimum shift position and reduces shifting and lock-up shocks.

SENSORS		TCM		ACTUATORS
Park/neutral position (PNP) switch Throttle position sensor Closed throttle position switch Wide open throttle position switch Engine speed signal A/T fluid temperature sensor Revolution sensor Vehicle speed sensor Overdrive control switch ASCD control unit	▶	Shift control Line pressure control Lock-up control Overrun clutch control Timing control Fail-safe control Self-diagnosis CONSULT-II communication line control Duet-EA control	▶	Shift solenoid valve A Shift solenoid valve B Overrun clutch solenoid valve Torque converter clutch solenoid valve Line pressure solenoid valve O/D OFF indicator lamp

CONTROL SYSTEM

NDAT0015S02

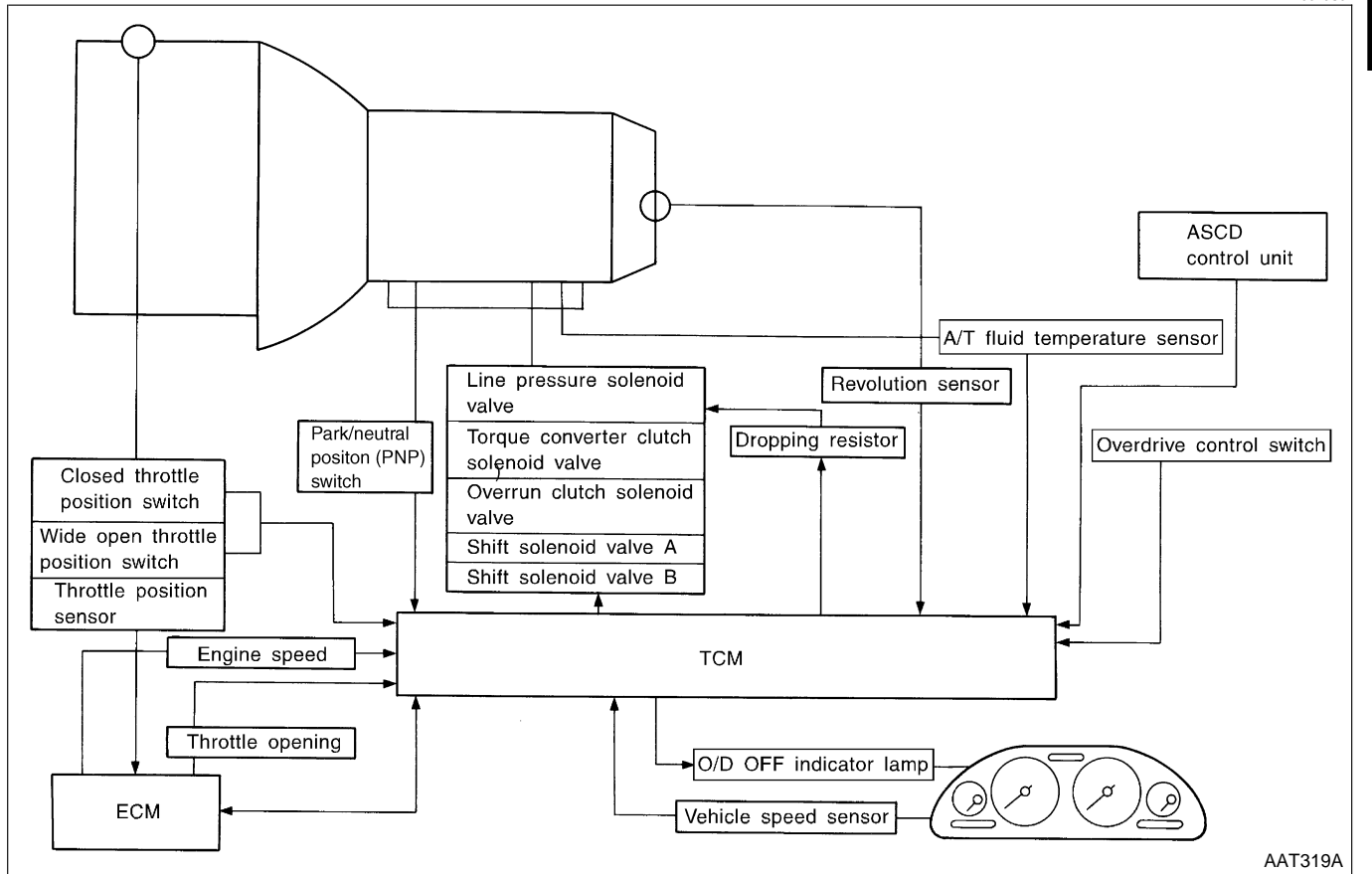

OVERALL SYSTEM

Control System (Cont'd)

TCM FUNCTION

=NDAT0015S03

The function of the TCM is to:

- Receive input signals sent from various switches and sensors.
- Determine required line pressure, shifting point, lock-up operation, and engine brake operation.
- Send required output signals to the respective solenoids.

INPUT/OUTPUT SIGNAL OF TCM

NDAT0015S04

	Sensors and solenoid valves	Function
Input	Park/neutral position (PNP) switch	Detects select lever position and sends a signal to TCM.
	Throttle position sensor	Detects throttle valve position and sends a signal to TCM.
	Closed throttle position switch	Detects throttle valve's fully-closed position and sends a signal to TCM.
	Wide open throttle position switch	Detects a throttle valve position of greater than 1/2 of full throttle and sends a signal to TCM.
	Engine speed signal	From ECM.
	A/T fluid temperature sensor	Detects transmission fluid temperature and sends a signal to TCM.
	Revolution sensor	Detects output shaft rpm and sends a signal to TCM.
	Vehicle speed sensor	Used as an auxiliary vehicle speed sensor. Sends a signal when revolution sensor (installed on transmission) malfunctions.
	Overdrive control switch	Sends a signal, which prohibits a shift to D ₄ (overdrive) position, to the TCM.
	ASCD control unit	Sends the cruise signal and D ₄ (overdrive) cancellation signal from ASCD control unit to TCM.
Output	Shift solenoid valve A/B	Selects shifting point suited to driving conditions in relation to a signal sent from TCM.
	Line pressure solenoid valve	Regulates (or decreases) line pressure suited to driving conditions in relation to a signal sent from TCM.
	Torque converter clutch solenoid valve	Regulates (or decreases) lock-up pressure suited to driving conditions in relation to a signal sent from TCM.
	Overrun clutch solenoid valve	Controls an "engine brake" effect suited to driving conditions in relation to a signal sent from TCM.
	O/D OFF indicator lamp	Shows TCM faults, when A/T control components malfunction.

Control Mechanism

LINE PRESSURE CONTROL

=NDAT0016

NDAT0016S01

TCM has various line pressure control characteristics to meet the driving conditions.

An ON-OFF duty signal is sent to the line pressure solenoid valve based on TCM characteristics.

Hydraulic pressure on the clutch and brake is electronically controlled through the line pressure solenoid valve to accommodate engine torque. This results in smooth shift operation.

GI

MA

EM

LC

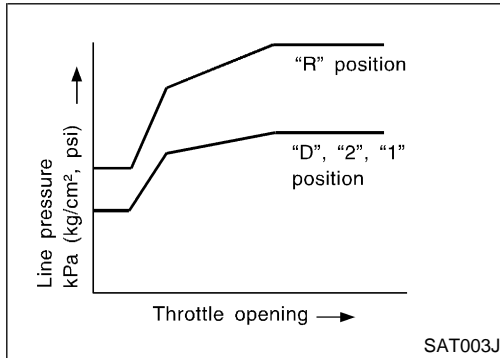

Normal Control

NDAT0016S0101

The line pressure to throttle opening characteristics is set for suitable clutch operation.

EC

FE

AT

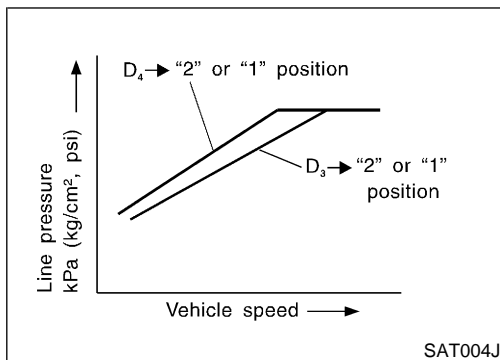

Back-up Control (Engine brake)

NDAT0016S0102

If the selector lever is shifted to 2 position while driving in D₄ (O/D) or D₃, great driving force is applied to the clutch inside the transmission. Clutch operating pressure (line pressure) must be increased to deal with this driving force.

SU

BR

ST

RS

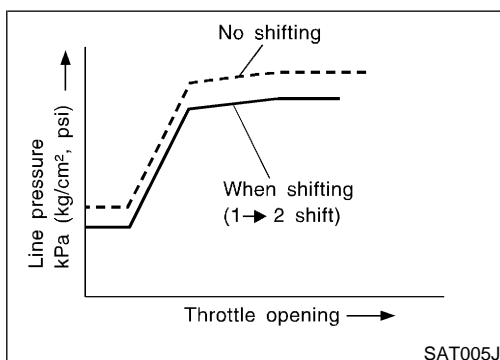

During Shift Change

NDAT0016S0103

The line pressure is temporarily reduced corresponding to a change in engine torque when shifting gears (that is, when the shift solenoid valve is switched for clutch operation) to reduce shifting shock.

BT

HA

SC

EL

At Low Fluid Temperature

NDAT0016S0104

- Fluid viscosity and frictional characteristics of the clutch facing change with fluid temperature. Clutch engaging or band-contacting pressure is compensated for, according to fluid temperature, to stabilize shifting quality.

IDX

OVERALL SYSTEM

Control Mechanism (Cont'd)

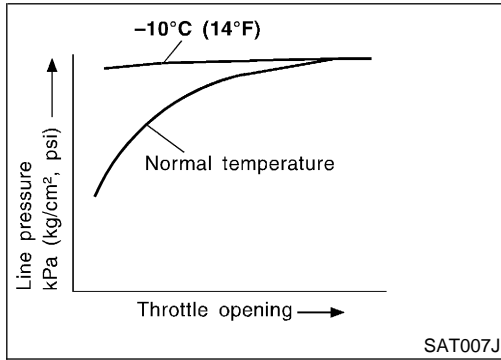
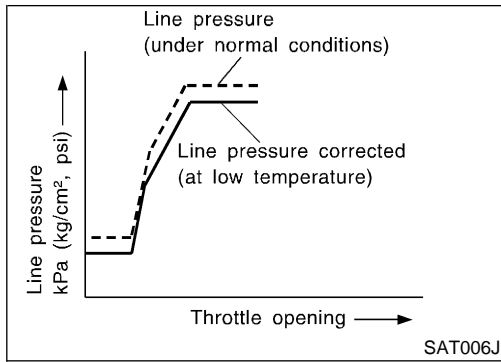

- The line pressure is reduced below 60°C (140°F) to prevent shifting shock due to low viscosity of automatic transmission fluid when temperature is low.
- Line pressure is increased to a maximum irrespective of the throttle opening when fluid temperature drops to -10°C (14°F). This pressure rise is adopted to prevent a delay in clutch and brake operation due to extreme drop of fluid viscosity at low temperature.

SHIFT CONTROL

The shift is regulated entirely by electronic control to accommodate vehicle speed and varying engine operations. This is accomplished by electrical signals transmitted by the revolution sensor and throttle position sensor. This results in improved acceleration performance and fuel economy.

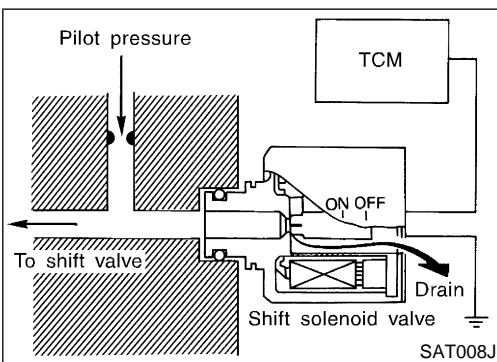

Control of Shift Solenoid Valves A and B

The TCM activates shift solenoid valves A and B according to signals from the throttle position sensor and revolution sensor to select the optimum gear position on the basis of the shift schedule memorized in the TCM.

The shift solenoid valve performs simple ON-OFF operation. When set to ON, the drain circuit closes and pilot pressure is applied to the shift valve.

Relation between shift solenoid valves A and B and gear positions

Shift solenoid valve	Gear position				
	D ₁ , 2 ₁ , 1 ₁	D ₂ , 2 ₂ , 1 ₂	D ₃	D ₄ (O/D)	N-P
A	ON (Closed)	OFF (Open)	OFF (Open)	ON (Closed)	ON (Closed)
B	ON (Closed)	ON (Closed)	OFF (Open)	OFF (Open)	ON (Closed)

OVERALL SYSTEM

Control Mechanism (Cont'd)

Control of Shift Valves A and B

NDAT0016S0202

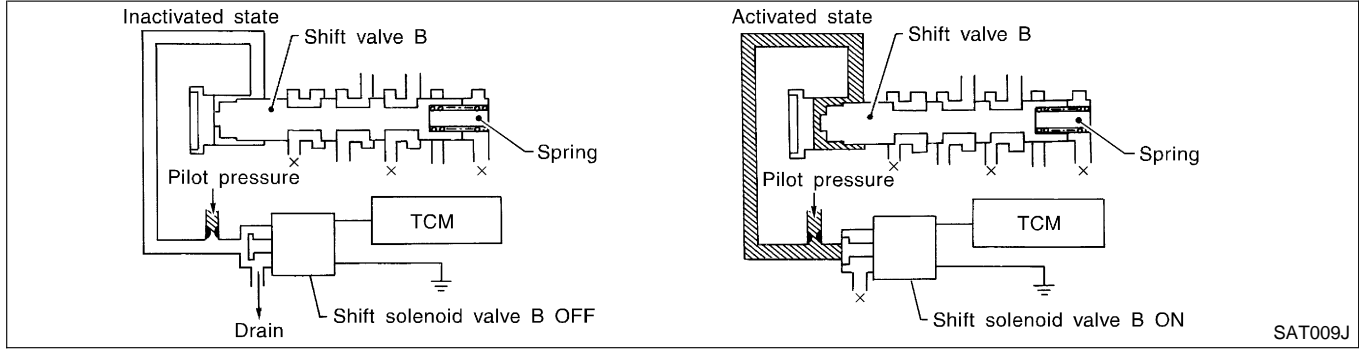

GI
MA
EM
LC

Pilot pressure generated by the operation of shift solenoid valves A and B is applied to the end face of shift valves A and B. The drawing above shows the operation of shift valve B. When the shift solenoid valve is ON, pilot pressure applied to the end face of the shift valve overcomes spring force, moving the valve upward.

EC
FE

LOCK-UP CONTROL

NDAT0016S03

The torque converter clutch piston in the torque converter is locked to eliminate torque converter slip to increase power transmission efficiency. The solenoid valve is controlled by an ON-OFF duty signal sent from the TCM. The signal is converted to an oil pressure signal which controls the lock-up piston.

AT
AX

Conditions for Lock-up Operation

NDAT0016S0301

When vehicle is driven in 4th gear position, vehicle speed and throttle opening are detected. If the detected values fall within the lock-up zone memorized in the TCM, lock-up is performed.

SU
BR

Overdrive control switch	ON	OFF
Selector lever	D position	
Gear position	D ₄	D ₃
Vehicle speed sensor	More than set value	
Throttle position sensor	Less than set opening	
Closed throttle position switch	OFF	
A/T fluid temperature sensor	More than 40°C (104°F)	

ST
RS
BT
HA

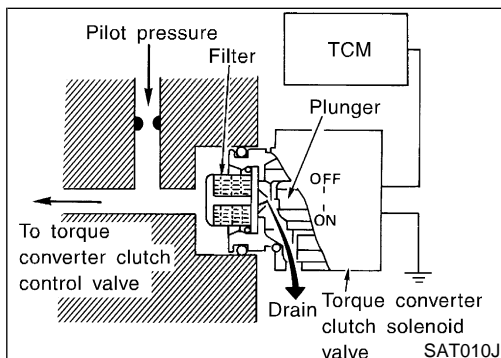

Torque Converter Clutch Solenoid Valve Control

NDAT0016S0302

The torque converter clutch solenoid valve is controlled by the TCM. The plunger closes the drain circuit during the OFF period, and opens the circuit during the ON period. If the percentage of OFF-time increases in one cycle, the pilot pressure drain time is reduced and pilot pressure remains high.

The torque converter clutch piston is designed to slip to adjust the ratio of ON-OFF, thereby reducing lock-up shock.

IDX

SC
EL

OVERALL SYSTEM

Control Mechanism (Cont'd)

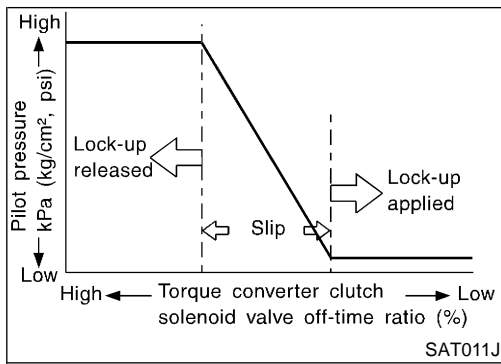

OFF-time INCREASING
 ↓
 Amount of drain DECREASING
 ↓
 Pilot pressure HIGH
 ↓
 Lock-up RELEASING

Torque Converter Clutch Control Valve Operation

NDAT0016S0303

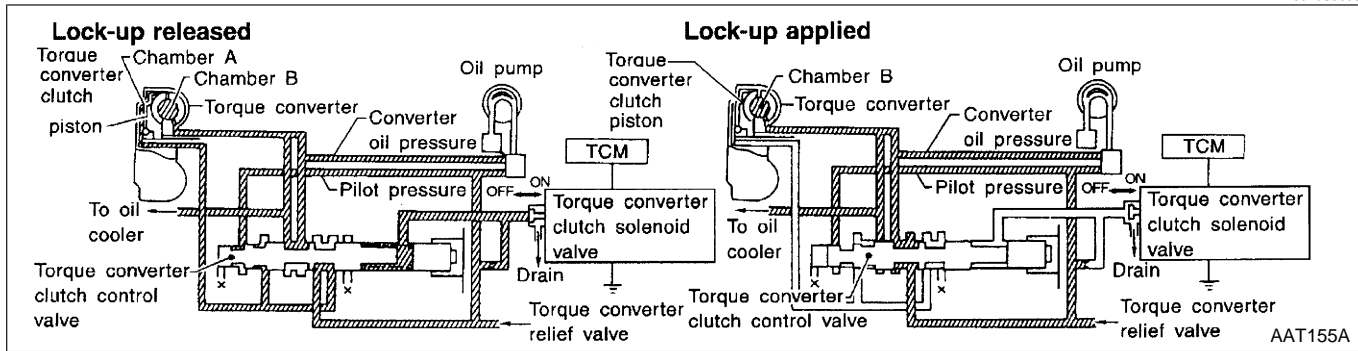

AAT155A

Lock-up released

The OFF-duration of the torque converter clutch solenoid valve is long, and pilot pressure is high. The pilot pressure pushes the end face of the torque converter clutch control valve in combination with spring force to move the valve to the left. As a result, converter pressure is applied to chamber A (torque converter clutch piston release side). Accordingly, the torque converter clutch piston remains unlocked.

Lock-up applied

When the OFF-duration of the torque converter clutch solenoid valve is short, pilot pressure drains and becomes low. Accordingly, the control valve moves to the right by the pilot pressure of the other circuit and converter pressure. As a result, converter pressure is applied to chamber B, keeping the torque converter clutch piston applied.

Also smooth lock-up is provided by transient application and release of the lock-up.

OVERRUN CLUTCH CONTROL (ENGINE BRAKE CONTROL)

NDAT0016S04

Forward one-way clutch is used to reduce shifting shocks in downshifting operations. This clutch transmits engine torque to the wheels. However, drive force from the wheels is not transmitted to the engine because the one-way clutch rotates idle. This means the engine brake is not effective.

The overrun clutch operates when the engine brake is needed.

Overrun Clutch Operating Conditions

NDAT0016S0401

Selector lever position	Gear position	Throttle opening
D position	D ₁ , D ₂ , D ₃ gear position	Less than 3/16
2 position	2 ₁ , 2 ₂ gear position	
1 position	1 ₁ , 1 ₂ gear position	At any position

OVERALL SYSTEM

Control Mechanism (Cont'd)

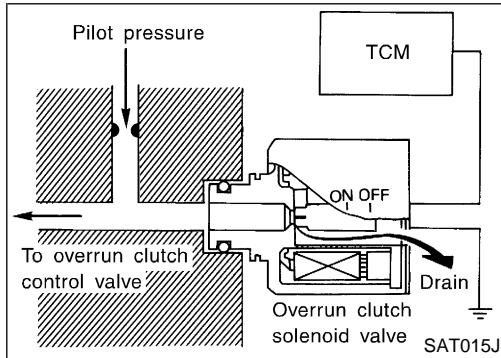
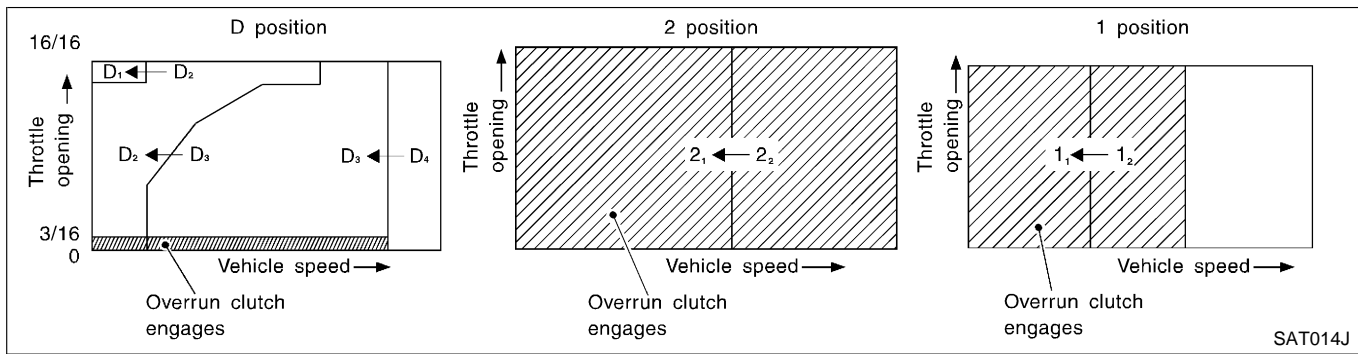

Overrun Clutch Solenoid Valve Control

The overrun clutch solenoid valve is operated by an ON-OFF signal transmitted by the TCM to provide overrun clutch control (engine brake control).

When this solenoid valve is ON, the pilot pressure drain port closes. When it is OFF, the drain port opens.

During the solenoid valve ON pilot pressure is applied to the end face of the overrun clutch control valve.

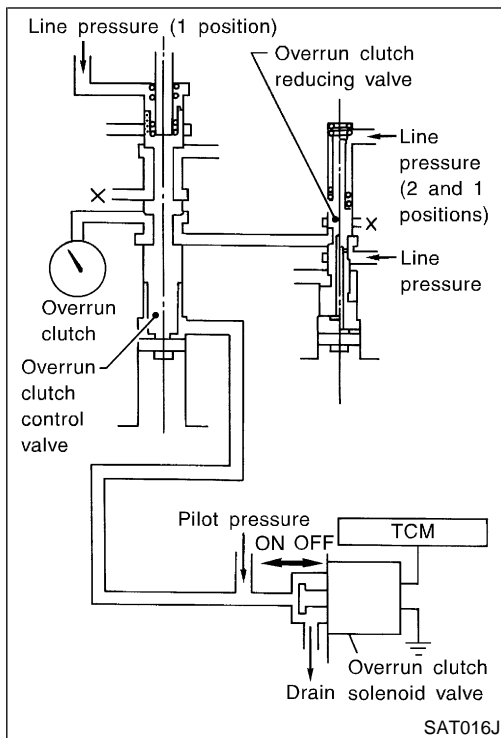

Overrun Clutch Control Valve Operation

When the solenoid valve is ON, pilot pressure is applied to the overrun clutch control valve. This pushes up the overrun clutch control valve. The line pressure is then shut off so that the clutch does not engage.

When the solenoid valve is OFF, pilot pressure is not generated. At this point, the overrun clutch control valve moves downward by spring force. As a result, overrun clutch operation pressure is provided by the overrun clutch reducing valve. This causes the overrun clutch to engage.

In the 1 position, the overrun clutch control valve remains pushed down so that the overrun clutch is engaged at all times.

Control Valve

FUNCTION OF CONTROL VALVES

Valve name	Function
Pressure regulator valve, plug and sleeve plug	Regulates oil discharged from the oil pump to provide optimum line pressure for all driving conditions.
Pressure modifier valve and sleeve	Used as a signal supplementary valve to the pressure regulator valve. Regulates pressure-modifier pressure (signal pressure) which controls optimum line pressure for all driving conditions.

OVERALL SYSTEM

Control Valve (Cont'd)

Valve name	Function
Pilot valve	Regulates line pressure to maintain a constant pilot pressure level which controls lock-up mechanism, overrun clutch, shift timing.
Accumulator control valve	Regulates accumulator back-pressure to pressure suited to driving conditions.
Manual valve	Directs line pressure to oil circuits corresponding to select positions. Hydraulic pressure drains when the shift lever is in Neutral.
Shift valve A	Simultaneously switches four oil circuits using output pressure of shift solenoid valve A to meet driving conditions (vehicle speed, throttle opening, etc.). Provides automatic down-shifting and up-shifting (1st → 2nd → 3rd → 4th gears/4th → 3rd → 2nd → 1st gears) in combination with shift valve B.
Shift valve B	Simultaneously switches three oil circuits using output pressure of shift solenoid valve B in relation to driving conditions (vehicle speed, throttle opening, etc.). Provides automatic down-shifting and up-shifting (1st → 2nd → 3rd → 4th gears/4th → 3rd → 2nd → 1st gears) in combination with shift valve A.
Overrun clutch control valve	Switches hydraulic circuits to prevent engagement of the overrun clutch simultaneously with application of the brake band in D ₄ . (Interlocking occurs if the overrun clutch engages during D ₄ .)
"1" reducing valve	Reduces low & reverse brake pressure to dampen engine-brake shock when down-shifting from the 1 position 1 ₂ to 1 ₁ .
Overrun clutch reducing valve	Reduces oil pressure directed to the overrun clutch and prevents engine-brake shock. In 1 and 2 positions, line pressure acts on the overrun clutch reducing valve to increase the pressure-regulating point, with resultant engine brake capability.
Torque converter relief valve	Prevents an excessive rise in torque converter pressure.
Torque converter clutch control valve, plug and sleeve	Activates or inactivates the lock-up function. Also provides smooth lock-up through transient application and release of the lock-up system.
1-2 accumulator valve and piston	Dampens the shock encountered when 2nd gear band servo contracts, and provides smooth shifting.

Introduction

NDAT0018

The A/T system has two self-diagnostic systems.

The first is the emission-related on board diagnostic system (OBD-II) performed by the TCM (transmission control module) in combination with the ECM. The malfunction is indicated by the MIL (malfunction indicator lamp) and is stored as a DTC in the ECM memory but not the TCM memory.

The second is the TCM original self-diagnosis indicated by the O/D OFF indicator lamp. The malfunction is stored in the TCM memory. The detected items are overlapped with OBD-II self-diagnostic items. For detail, refer to "SELF-DIAGNOSTIC RESULT TEST MODE", AT-40.

OBD-II Function for A/T System

NDAT0019

The ECM provides emission-related on board diagnostic (OBD-II) functions for the A/T system. One function is to receive a signal from the TCM used with OBD-related parts of the A/T system. The signal is sent to the ECM when a malfunction occurs in the corresponding OBD-related part. The other function is to indicate a diagnostic result by means of the MIL (malfunction indicator lamp) on the instrument panel. Sensors, switches and solenoid valves are used as sensing elements.

The MIL automatically illuminates in One or Two Trip Detection Logic when a malfunction is sensed in relation to A/T system parts.

One or Two Trip Detection Logic of OBD-II

NDAT0020

ONE TRIP DETECTION LOGIC

NDAT0020S01

If a malfunction is sensed during the first test drive, the MIL will illuminate and the malfunction will be stored in the ECM memory as a DTC. The TCM is not provided with such a memory function.

TWO TRIP DETECTION LOGIC

NDAT0020S02

When a malfunction is sensed during the first test drive, it is stored in the ECM memory as a 1st trip DTC (diagnostic trouble code) or 1st trip freeze frame data. At this point, the MIL will not illuminate. — First Trip
If the same malfunction as that experienced during the first test drive is sensed during the second test drive, the MIL will illuminate. — Second Trip

A/T-related parts for which the MIL illuminates during the first or second test drive are listed below.

Items	MIL	
	One trip detection	Two trip detection
Shift solenoid valve A — DTC: P0750 (1108)	X	
Shift solenoid valve B — DTC: P0755 (1201)	X	
Throttle position sensor or switch — DTC: P1705 (1206)	X	
Except above		X

The "trip" in the "One or Two Trip Detection Logic" means a driving mode in which self-diagnosis is performed during vehicle operation.

OBD-II Diagnostic Trouble Code (DTC)

NDAT0021

HOW TO READ DTC AND 1ST TRIP DTC

NDAT0021S01

DTC and 1st trip DTC can be read by the following methods.

- (No Tools)** The number of blinks of the malfunction indicator lamp in the Diagnostic Test Mode II (Self-Diagnostic Results) Examples: 1101, 1102, 1103, 1104, etc. For details, refer to **EC-63**, "Malfunction Indicator Lamp (MIL)".
These DTCs are controlled by NISSAN.
- (With CONSULT-II or GST)** CONSULT-II or GST (Generic Scan Tool) Examples: P0705, P0710, P0720, P0725, etc.
These DTCs are prescribed by SAE J2012.
(CONSULT-II also displays the malfunctioning component or system.)

 - 1st trip DTC No. is the same as DTC No.**
 - Output of the diagnostic trouble code indicates that the indicated circuit has a malfunction. However, in case of the Mode II and GST they do not indicate whether the malfunction is still occurring or occurred in the past and returned to normal. CONSULT-II can identify them as shown. Therefore, using CONSULT-II (if available) is recommended.**

ON BOARD DIAGNOSTIC SYSTEM DESCRIPTION

OBD-II Diagnostic Trouble Code (DTC) (Cont'd)

A sample of CONSULT-II display for DTC and 1st trip DTC is shown below. DTC or 1st trip DTC of a malfunction is displayed in SELF-DIAGNOSIS mode for "ENGINE" with CONSULT-II. Time data indicates how many times the vehicle was driven after the last detection of a DTC.

SELECT SYSTEM
A/T
ENGINE

SAT014K

If the DTC is being detected currently, the time data will be "0".

SELF-DIAG RESULTS	
DTC RESULTS	TIME
PNP SW/CIRC [P0705]	0

SAT015K

If a 1st trip DTC is stored in the ECM, the time data will be "1t".

SELF-DIAG RESULTS	
DTC RESULTS	TIME
PNP SW/CIRC [P0705]	1 t

SAT016K

Freeze Frame Data and 1st Trip Freeze Frame Data

NDAT0021S0101

The ECM has a memory function, which stores the driving condition such as fuel system status, calculated load value, engine coolant temperature, short term fuel trim, long term fuel trim, engine speed and vehicle speed at the moment the ECM detects a malfunction.

Data which are stored in the ECM memory, along with the 1st trip DTC, are called 1st trip freeze frame data, and the data, stored together with the DTC data, are called freeze frame data and displayed on CONSULT-II or GST. The 1st trip freeze frame data can only be displayed on the CONSULT-II screen, not on the GST. For detail, refer to **EC-69**, "CONSULT-II".

Only one set of freeze frame data (either 1st trip freeze frame data of freeze frame data) can be stored in the ECM. 1st trip freeze frame data is stored in the ECM memory along with the 1st trip DTC. There is no priority for 1st trip freeze frame data and it is updated each time a different 1st trip DTC is detected. However, once freeze frame data (2nd trip detection/MIL on) is stored in the ECM memory, 1st trip freeze frame data is no longer stored. Remember, only one set of freeze frame data can be stored in the ECM. The ECM has the following priorities to update the data.

ON BOARD DIAGNOSTIC SYSTEM DESCRIPTION

OBD-II Diagnostic Trouble Code (DTC) (Cont'd)

Priority	Items	
1	Freeze frame data	Misfire — DTC: P0300 - P0306 (0701, 0603 - 0608) Fuel Injection System Function — DTC: P0171 (115), P0172 (114), P0174 (0209), P0175 (0210)
2		Except the above items (Includes A/T related items)
3	1st trip freeze frame data	

Both 1st trip freeze frame data and freeze frame data (along with the DTCs) are cleared when the ECM memory is erased.

HOW TO ERASE DTC

The diagnostic trouble code can be erased by CONSULT-II, GST or ECM DIAGNOSTIC TEST MODE as described following.

- If the battery terminal is disconnected, the diagnostic trouble code will be lost within 24 hours.
- When you erase the DTC, using CONSULT-II or GST is easier and quicker than switching the mode selector on the ECM.

The following emission-related diagnostic information is cleared from the ECM memory when erasing DTC related to OBD-II. For details, refer to **EC-51**, "Emission-related Diagnostic Information".

- Diagnostic trouble codes (DTC)
- 1st trip diagnostic trouble codes (1st trip DTC)
- Freeze frame data
- 1st trip freeze frame data
- System readiness test (SRT) codes
- Test values

Ⓜ HOW TO ERASE DTC (WITH CONSULT-II)

- If a DTC is displayed for both ECM and TCM, it needs to be erased for both ECM and TCM.
1. If the ignition switch stays ON after repair work, be sure to turn ignition switch OFF once. Wait at least 5 seconds and then turn it ON (engine stopped) again.
 2. Turn CONSULT-II "ON" and touch "A/T".
 3. Touch "SELF-DIAGNOSIS".
 4. Touch "ERASE". (The DTC in the TCM will be erased.) Then touch "BACK" twice.
 5. Touch "ENGINE".
 6. Touch "SELF-DIAGNOSIS".
 7. Touch "ERASE". (The DTC in the ECM will be erased.)

GI

MA

EM

LC

EC

FE

AT

AX

SU

BR

ST

RS

BT

HA

SC

EL

IDX

ON BOARD DIAGNOSTIC SYSTEM DESCRIPTION

OBD-II Diagnostic Trouble Code (DTC) (Cont'd)

How to erase DTC (With CONSULT-II)

1. If the ignition switch stays "ON" after repair work, be sure to turn ignition switch "OFF" once. Wait at least 5 seconds and then turn it "ON" (engine stopped) again.

SELECT SYSTEM
ENGINE
A/T

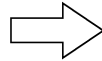

SELECT DIAG MODE
SELF-DIAG RESULTS
DATA MONITOR
DTC WORK SUPPORT
TCM PART NUMBER

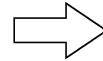

SELF-DIAG RESULTS	
DTC RESULTS	TIME
SHIFT SOLENOID/V A	

2. Turn **CONSULT-II** "ON", and touch "A/T".
3. Touch "SELF-DIAG RESULTS".
4. Touch "ERASE". (The DTC in the TCM will be erased.)

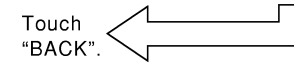
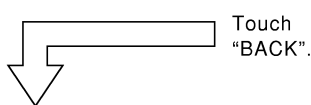

SELECT SYSTEM
ENGINE
A/T

SELECT DIAG MODE
WORK SUPPORT
SELF-DIAG RESULTS
DATA MONITOR
ACTIVE TEST
DTC & SRT CONFIRMATION
ECM PART NUMBER

SELF DIAG RESULTS	
DTC RESULTS	TIME
SFT SOL A/CIRC [P0750]	0

5. Touch "ENGINE".
6. Touch "SELF-DIAG RESULTS".
7. Touch "ERASE". (The DTC in the ECM will be erased.)

SEF966XA

HOW TO ERASE DTC (WITH GST)

1. If the ignition switch stays ON after repair work, be sure to turn ignition switch OFF once. Wait at least 5 seconds and then turn it ON (engine stopped) again.
2. Perform "OBD-II SELF-DIAGNOSTIC PROCEDURE (NO TOOLS)". Refer to AT-48. (The engine warm-up step can be skipped when performing the diagnosis only to erase the DTC.)
3. Select Mode 4 with Generic Scan Tool (GST). For details, refer to **EC-62**, "Generic Scan Tool (GST)".

NDAT0021S04

HOW TO ERASE DTC (NO TOOLS)

1. If the ignition switch stays ON after repair work, be sure to turn ignition switch OFF once. Wait at least 5 seconds and then turn it ON (engine stopped) again.
2. Perform "TCM SELF-DIAGNOSTIC PROCEDURE (NO TOOLS)". Refer to AT-48. (The engine warm-up step can be skipped when performing the diagnosis only to erase the DTC.)
3. Change the diagnostic test mode from Mode II to Mode I by turning the mode selector on the ECM. Refer to **EC-63**, "Description".

NDAT0021S05

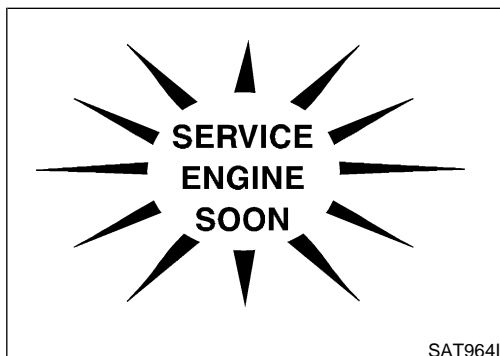

Malfunction Indicator Lamp (MIL)

1. The malfunction indicator lamp will light up when the ignition switch is turned ON without the engine running. This is for checking the lamp.
 - If the malfunction indicator lamp does not light up, refer to **EL-101**, "Warning Lamps/System Description" or **EC-63**, "Malfunction Indicator Lamp (MIL)".
2. When the engine is started, the malfunction indicator lamp should go off. If the lamp remains on, the on board diagnostic system has detected an emission-related (OBD-II) malfunction. For detail,

NDAT0022

refer to **EC-50**, "ON BOARD DIAGNOSTIC SYSTEM DESCRIPTION".

GI
MA
EM
LC
EC
FE
AT
AX
SU
BR
ST
RS
BT
HA
SC
EL

CONSULT-II

After performing "SELF-DIAGNOSTIC PROCEDURE (WITH CONSULT-II)" (AT-39), place check marks for results on the "Diagnostic Worksheet", AT-57. Reference pages are provide following the items.

NOTICE:

- 1) The CONSULT-II electrically displays shift timing and lock-up timing (that is, operation timing of each solenoid).
Check for time difference between actual shift timing and the CONSULT-II display. If the difference is noticeable, mechanical parts (except solenoids, sensors, etc.) may be malfunctioning. Check mechanical parts using applicable diagnostic procedures.
- 2) Shift schedule (which implies gear position) displayed on CONSULT-II and that indicated in Service Manual may differ slightly. This occurs because of the following reasons:
 - Actual shift schedule has more or less tolerance or allowance,
 - Shift schedule indicated in Service Manual refers to the point where shifts start, and
 - Gear position displayed on CONSULT-II indicates the point where shifts are completed.
- 3) Shift solenoid valve "A" or "B" is displayed on CONSULT-II at the start of shifting. Gear position is displayed upon completion of shifting (which is computed by TCM).
- 4) Additional CONSULT-II information can be found in the Operation Manual supplied with the CONSULT-II unit.

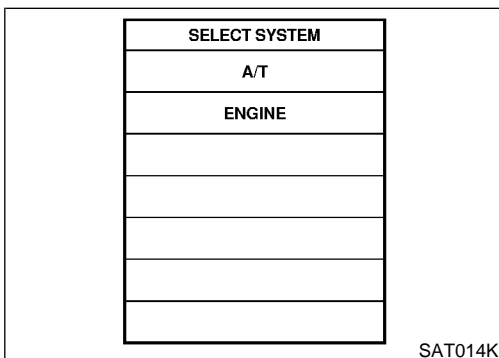

Ⓜ SELF-DIAGNOSTIC PROCEDURE (WITH CONSULT-II)

1. Turn on CONSULT-II and touch "ENGINE" for OBD-II detected items or touch "A/T" for TCM self-diagnosis.
If A/T is not displayed, check TCM power supply and ground circuit. Refer to AT-100, "TROUBLE DIAGNOSIS FOR POWER SUPPLY". If result is NG, refer to **EL-10**, "POWER SUPPLY ROUTING".

ON BOARD DIAGNOSTIC SYSTEM DESCRIPTION

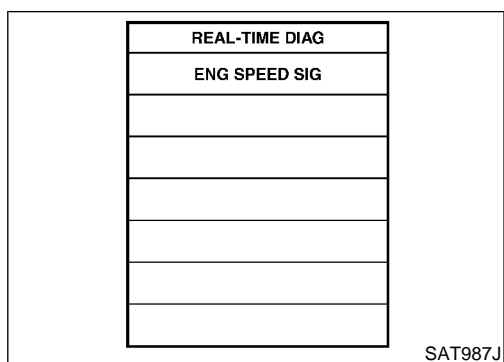

CONSULT-II (Cont'd)



2. Touch "SELF-DIAGNOSIS".
Display shows malfunction experienced since the last erasing operation.
CONSULT-II performs real-time diagnosis.
Also, any malfunction detected while in this mode will be displayed at real time.



SELF-DIAGNOSTIC RESULT TEST MODE

INDAT0023S03

Detected items (Screen terms for CONSULT-II, "SELF-DIAGNOSIS" test mode)		Malfunction is detected when ...	TCM self-diagnosis	OBD-II (DTC)
"A/T"	"ENGINE"		 Available by O/D OFF indicator lamp or "A/T" on CONSULT-II	 Available by malfunction indicator lamp*2, "ENGINE" on CONSULT-II or GST
—	PNP SW/CIRC	● TCM does not receive the correct voltage signal (based on the gear position) from the switch.	—	P0705
VHCL SPEED SEN-A/T	VEH SPD SEN/CIR AT	● TCM does not receive the proper voltage signal from the sensor.	X	P0720
VHCL SPEED SEN-MTR	—	● TCM does not receive the proper voltage signal from the sensor.	X	—
—	A/T 1ST GR FNCTN	● A/T cannot be shifted to the 1st gear position even if electrical circuit is good.	—	P0731*1
—	A/T 2ND GR FNCTN	● A/T cannot be shifted to the 2nd gear position even if electrical circuit is good.	—	P0732*1
—	A/T 3RD GR FNCTN	● A/T cannot be shifted to the 3rd gear position even if electrical circuit is good.	—	P0733*1
—	A/T 4TH GR FNCTN	● A/T cannot be shifted to the 4th gear position even if electrical circuit is good.	—	P0734*1
—	A/T TCC S/V FNCTN	● A/T cannot perform lock-up even if electrical circuit is good.	—	P0744*1
SHIFT SOLENOID/V A	SFT SOL A/CIRC	● TCM detects an improper voltage drop when it tries to operate the solenoid valve.	X	P0750

ON BOARD DIAGNOSTIC SYSTEM DESCRIPTION

CONSULT-II (Cont'd)

Detected items (Screen terms for CONSULT-II, "SELF-DI-AGNOSIS" test mode)		Malfunction is detected when ...	TCM self-diagnosis	OBD-II (DTC)	
"A/T"	"ENGINE"		 Available by O/D OFF indicator lamp or "A/T" on CONSULT-II	 Available by malfunction indicator lamp*2, "ENGINE" on CON- SULT-II or GST	
Shift solenoid valve B		● TCM detects an improper volt- age drop when it tries to operate the solenoid valve.	X	P0755	LC
SHIFT SOLENOID/V B	SFT SOL B/CIRC				
Overrun clutch solenoid valve		● TCM detects an improper volt- age drop when it tries to operate the solenoid valve.	X	P1760	EC
OVERRUN CLUTCH S/V	O/R CLUCH SOL/ CIRC				
T/C clutch solenoid valve		● TCM detects an improper volt- age drop when it tries to operate the solenoid valve.	X	P0740	AT
T/C CLUTCH SOL/V	TCC SOLENOID/ CIRC				
Line pressure solenoid valve		● TCM detects an improper volt- age drop when it tries to operate the solenoid valve.	X	P0745	AX
LINE PRESSURE S/V	L/PRESS SOL/ GRC				
Throttle position sensor Throttle position switch		● TCM receives an excessively low or high voltage from the sensor.	X	P1705	SU
THROTTLE POSI SEN	TP SEN/CIRC A/T				
Engine speed signal		● TCM does not receive the proper voltage signal from the ECM.	X	P0725	ST
ENGINE SPEED SIG					
A/T fluid temperature sensor		● TCM receives an excessively low or high voltage from the sensor.	X	P0710	RS
BATT/FLUID TEMP SEN	ATF TEMP SEN/ CIRC				
TCM (RAM)		● TCM memory (RAM) is malfunc- tioning	—	—	BT
CONTROL UNIT (RAM)	—				
TCM (ROM)		● TCM memory (ROM) is malfunc- tioning	—	—	HA
CONTROL UNIT (ROM)	—				
TCM (EEPROM)		● TCM Memory (EEPROM) is mal- functioning	—	—	EL
CONTROL UNIT (EEPROM)	—				
Initial start		● This is not a malfunction mes- sage (Whenever shutting off a power supply to the TCM, this message appears on the screen.)	X	—	IDX
INITIAL START	—				
No failure (NO SELF DIAGNOSTIC FAILURE INDI- CATED FURTHER TESTING MAY BE REQUIRED**)		● No failure has been detected.	X	X	

X: Applicable

—: Not applicable

ON BOARD DIAGNOSTIC SYSTEM DESCRIPTION

CONSULT-II (Cont'd)

*1: These malfunctions cannot be displayed by MIL SERVICE ENGINE SOON if another malfunction is assigned to MIL.

*2: Refer to "Malfunction Indicator Lamp (MIL)", **EC-63**.

DATA MONITOR MODE (A/T)

NDAT0023S04

Item	Display	Monitor item		Description	Remarks
		TCM input signals	Main signals		
Vehicle speed sensor 1 (A/T) (Revolution sensor)	VHCL/S SE-A/T [km/h] or [mph]	X	—	<ul style="list-style-type: none"> Vehicle speed computed from signal of revolution sensor is displayed. 	When racing engine in N or P with vehicle stationary, CONSULT-II data may not indicate 0 km/h (0 mph).
Vehicle speed sensor 2 (Meter)	VHCL/S SE-MTR [km/h] or [mph]	X	—	<ul style="list-style-type: none"> Vehicle speed computed from signal of vehicle speed sensor is displayed. 	Vehicle speed display may not be accurate under approx. 10 km/h (6 mph). It may not indicate 0 km/h (0 mph) when vehicle is stationary.
Throttle position sensor	THRTL POS SEN [V]	X	—	<ul style="list-style-type: none"> Throttle position sensor signal voltage is displayed. 	
A/T fluid temperature sensor	FLUID TEMP SE [V]	X	—	<ul style="list-style-type: none"> A/T fluid temperature sensor signal voltage is displayed. Signal voltage lowers as fluid temperature rises. 	
Battery voltage	BATTERY VOLT [V]	X	—	<ul style="list-style-type: none"> Source voltage of TCM is displayed. 	
Engine speed	ENGINE SPEED [rpm]	X	X	<ul style="list-style-type: none"> Engine speed, computed from engine speed signal, is displayed. 	Engine speed display may not be accurate under approx. 800 rpm. It may not indicate 0 rpm even when engine is not running.
Overdrive control switch	OVERDRIVE SW [ON/OFF]	X	—	<ul style="list-style-type: none"> ON/OFF state computed from signal of overdrive control SW is displayed. 	
PN position (PNP) switch	PN POSI SW [ON/OFF]	X	—	<ul style="list-style-type: none"> ON/OFF state computed from signal of PN position SW is displayed. 	
R position switch	R POSITION SW [ON/OFF]	X	—	<ul style="list-style-type: none"> ON/OFF state computed from signal of R position SW is displayed. 	
D position switch	D POSITION SW [ON/OFF]	X	—	<ul style="list-style-type: none"> ON/OFF state computed from signal of D position SW is displayed. 	
2 position switch	2 POSITION SW [ON/OFF]	X	—	<ul style="list-style-type: none"> ON/OFF status, computed from signal of 2 position SW, is displayed. 	
1 position switch	1 POSITION SW [ON/OFF]	X	—	<ul style="list-style-type: none"> ON/OFF status, computed from signal of 1 position SW, is displayed. 	

ON BOARD DIAGNOSTIC SYSTEM DESCRIPTION

CONSULT-II (Cont'd)

Item	Display	Monitor item		Description	Remarks	
		TCM input signals	Main signals			
ASCD cruise signal	ASCD-CRUISE [ON/OFF]	X	—	<ul style="list-style-type: none"> Status of ASCD cruise signal is displayed. ON ... Cruising state OFF ... Normal running state 	<ul style="list-style-type: none"> This is displayed even when no ASCD is mounted. 	GI MA EM
ASCD OD cut signal	ASCD-OD CUT [ON/OFF]	X	—	<ul style="list-style-type: none"> Status of ASCD OD release signal is displayed. ON ... OD released OFF ... OD not released 	<ul style="list-style-type: none"> This is displayed even when no ASCD is mounted. 	LC EC
Kickdown switch	KICKDOWN SW [ON/OFF]	X	—	<ul style="list-style-type: none"> ON/OFF status, computed from signal of kickdown SW, is displayed. 	<ul style="list-style-type: none"> This is displayed even when no kickdown switch is equipped. 	FE
Closed throttle position switch	CLOSED THL/SW [ON/OFF]	X	—	<ul style="list-style-type: none"> ON/OFF status, computed from signal of closed throttle position SW, is displayed. 		AT
Wide open throttle position switch	W/O THRL/P-SW [ON/OFF]	X	—	<ul style="list-style-type: none"> ON/OFF status, computed from signal of wide open throttle position SW, is displayed. 		AX SU
Gear position	GEAR	—	X	<ul style="list-style-type: none"> Gear position data used for computation by TCM, is displayed. 		BR
Selector lever position	SLCT LVR POSI	—	X	<ul style="list-style-type: none"> Selector lever position data, used for computation by TCM, is displayed. 	<ul style="list-style-type: none"> A specific value used for control is displayed if fail-safe is activated due to error. 	ST
Vehicle speed	VEHICLE SPEED [km/h] or [mph]	—	X	<ul style="list-style-type: none"> Vehicle speed data, used for computation by TCM, is displayed. 		RS
Throttle position	THROTTLE POSI [8]	—	X	<ul style="list-style-type: none"> Throttle position data, used for computation by TCM, is displayed. 	<ul style="list-style-type: none"> A specific value used for control is displayed if fail-safe is activated due to error. 	BT HA
Line pressure duty	LINE PRES DTY [%]	—	X	<ul style="list-style-type: none"> Control value of line pressure solenoid valve, computed by TCM from each input signal, is displayed. 		SC EL
Torque converter clutch solenoid valve duty	TCC S/V DUTY [%]	—	X	<ul style="list-style-type: none"> Control value of torque converter clutch solenoid valve, computed by TCM from each input signal, is displayed. 		IDX
Shift solenoid valve A	SHIFT S/V A [ON/OFF]	—	X	<ul style="list-style-type: none"> Control value of shift solenoid valve A, computed by TCM from each input signal, is displayed. 	<ul style="list-style-type: none"> Control value of solenoid is displayed even if solenoid circuit is disconnected. The OFF signal is displayed if solenoid circuit is shorted. 	
Shift solenoid valve B	SHIFT S/V B [ON/OFF]	—	X	<ul style="list-style-type: none"> Control value of shift solenoid valve B, computed by TCM from each input signal, is displayed. 		

ON BOARD DIAGNOSTIC SYSTEM DESCRIPTION

CONSULT-II (Cont'd)

Item	Display	Monitor item		Description	Remarks
		TCM input signals	Main signals		
Overrun clutch solenoid valve	OVERRUN/C S/V [ON/OFF]	—	X	<ul style="list-style-type: none"> Control value of overrun clutch solenoid valve computed by TCM from each input signal is displayed. 	
Self-diagnosis display lamp (O/D OFF indicator lamp)	SELF-D DP LMP [ON/OFF]	—	X	<ul style="list-style-type: none"> Control status of O/D OFF indicator lamp is displayed. 	

X: Applicable

—: Not applicable

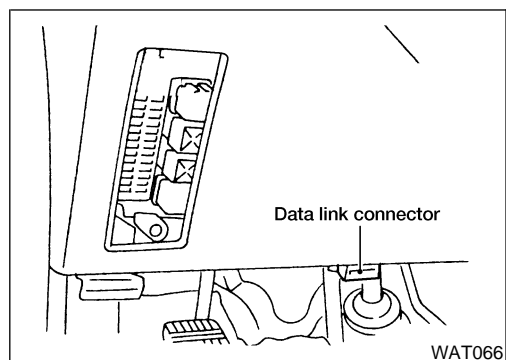

DTC WORK SUPPORT MODE WITH CONSULT-II CONSULT-II Setting Procedure

NDAT0023S05

NDAT0023S0501

1. Turn ignition switch OFF.
2. Connect CONSULT-II to data link connector. Data link connector is located in left side dash panel lower.

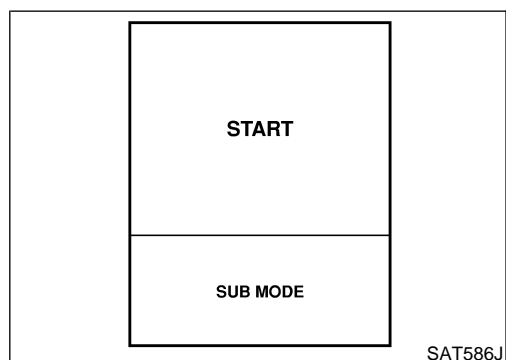

3. Turn ignition switch ON.
4. Touch "START".

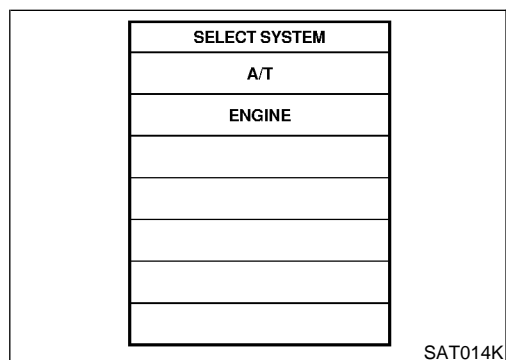

5. Touch "A/T".

ON BOARD DIAGNOSTIC SYSTEM DESCRIPTION

CONSULT-II (Cont'd)

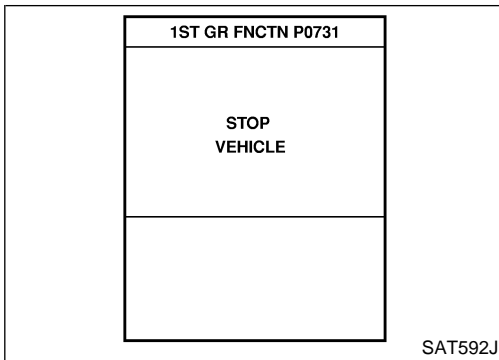

10. Stop vehicle. If "NG" appears on the screen, malfunction may exist. Go to "DIAGNOSTIC PROCEDURE".

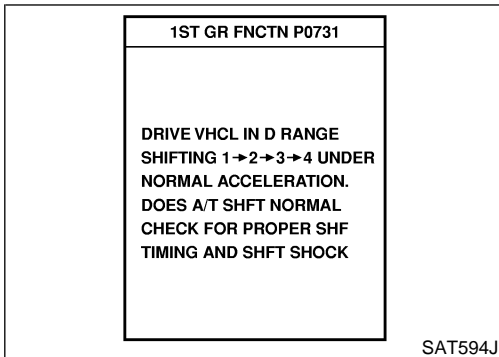
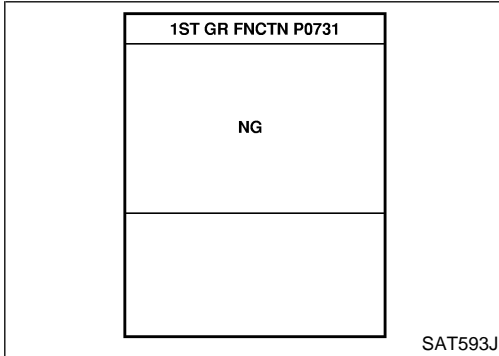

11. Perform test drive to check gear shift feeling in accordance with instructions displayed.

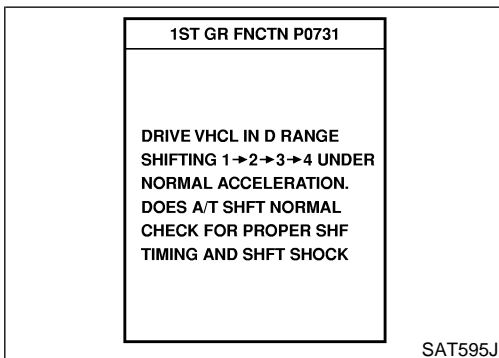

12. Touch "YES" or "NO".

ON BOARD DIAGNOSTIC SYSTEM DESCRIPTION

CONSULT-II (Cont'd)

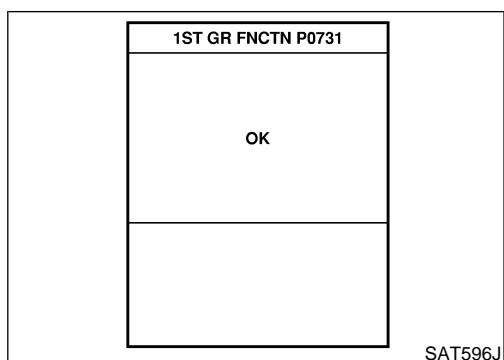

13. CONSULT-II procedure ended.
If "NG" appears on the screen, a malfunction may exist. Go to "DIAGNOSTIC PROCEDURE".

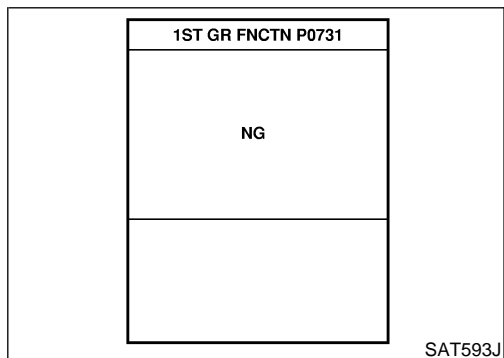

GI
MA
EM
LC
EC
FE
AT
AX

DTC WORK SUPPORT MODE

NDAT0023S06

DTC work support item	Description	Check item
1ST GR FNCTN P0731	Following items for "A/T 1st gear function (P0731)" can be confirmed. <ul style="list-style-type: none"> ● Self-diagnosis status (whether the diagnosis is being conducted or not) ● Self-diagnosis result (OK or NG) 	<ul style="list-style-type: none"> ● Shift solenoid valve A ● Shift solenoid valve B ● Each clutch ● Hydraulic control circuit
2ND GR FNCTN P0732	Following items for "A/T 2nd gear function (P0732)" can be confirmed. <ul style="list-style-type: none"> ● Self-diagnosis status (whether the diagnosis is being conducted or not) ● Self-diagnosis result (OK or NG) 	<ul style="list-style-type: none"> ● Shift solenoid valve B ● Each clutch ● Hydraulic control circuit
3RD GR FNCTN P0733	Following items for "A/T 3rd gear function (P0733)" can be confirmed. <ul style="list-style-type: none"> ● Self-diagnosis status (whether the diagnosis is being conducted or not) ● Self-diagnosis result (OK or NG) 	<ul style="list-style-type: none"> ● Shift solenoid valve A ● Each clutch ● Hydraulic control circuit
4TH GR FNCTN P0734	Following items for "A/T 4th gear function (P0734)" can be confirmed. <ul style="list-style-type: none"> ● Self-diagnosis status (whether the diagnosis is being conducted or not) ● Self-diagnosis result (OK or NG) 	<ul style="list-style-type: none"> ● Shift solenoid valve A ● Shift solenoid valve B ● Overrun clutch solenoid valve ● Line pressure solenoid valve ● Each clutch ● Hydraulic control circuit
TCC S/V FNCTN P0744	Following items for "A/T TCC S/V function (lock-up) (P0744)" can be confirmed. <ul style="list-style-type: none"> ● Self-diagnosis status (whether the diagnosis is being conducted or not) ● Self-diagnosis result (OK or NG) 	<ul style="list-style-type: none"> ● Torque converter clutch solenoid valve ● Each clutch ● Hydraulic control circuit

SU
BR
ST
RS
BT
HA
SC
EL
IDX

ON BOARD DIAGNOSTIC SYSTEM DESCRIPTION

Diagnostic Procedure Without CONSULT-II

Diagnostic Procedure Without CONSULT-II

 **OBD-II SELF-DIAGNOSTIC PROCEDURE (WITH GST)** NDAT0216
NDAT0216S01

Refer to **EC-81**, "Generic Scan Tool (GST)".

 **OBD-II SELF-DIAGNOSTIC PROCEDURE (NO TOOLS)**

Refer to **EC-63**, "Malfunction Indicator Lamp (MIL)".

NDAT0216S02

 **TCM SELF-DIAGNOSTIC PROCEDURE (NO TOOLS)**

NDAT0216S03

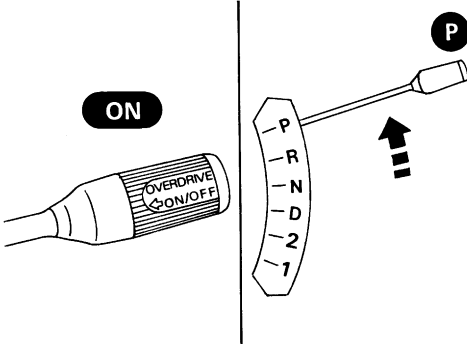
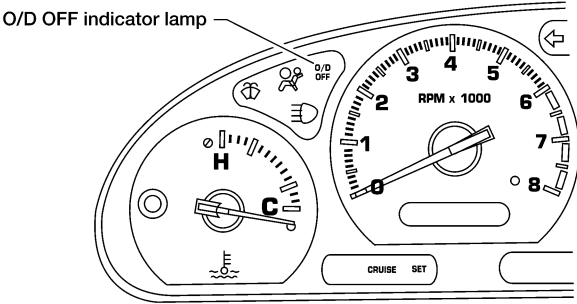
1	CHECK O/D OFF INDICATOR LAMP	
<ol style="list-style-type: none"> 1. Move selector lever to P position. Start engine and warm it up to normal engine operating temperature. 2. Turn ignition switch to OFF position. 3. Wait 5 seconds. 4. Turn ignition switch to ON position. (Do not start engine.) 		
		
<ol style="list-style-type: none"> 5. Does O/D OFF indicator lamp come on for about 2 seconds? 		
		
Yes or No		
Yes	▶	GO TO 2.
No	▶	Stop procedure. Perform "1. O/D OFF Indicator Lamp Does Not Come On", AT-216 before proceeding.

SAT421F

LAT383

ON BOARD DIAGNOSTIC SYSTEM DESCRIPTION

Diagnostic Procedure Without CONSULT-II (Cont'd)

2 JUDGEMENT PROCEDURE STEP 1

1. Turn ignition switch to OFF position.
2. Turn ignition switch to ACC position.
3. Move selector lever from P to D position.

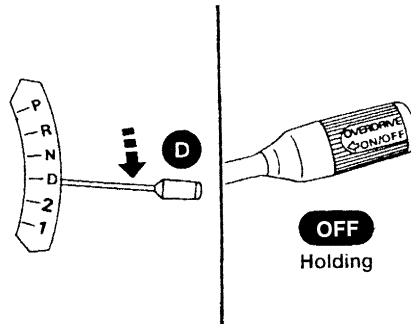

AAT156A

4. Turn ignition switch to ON position.
(Do not start engine.)
5. Depress and hold overdrive control switch in OFF position (the O/D OFF indicator lamp will be ON) until directed to release the switch. (If O/D OFF indicator lamp does not come on, refer to "JUDGEMENT PROCEDURE STEP 3 and 4", AT-51).

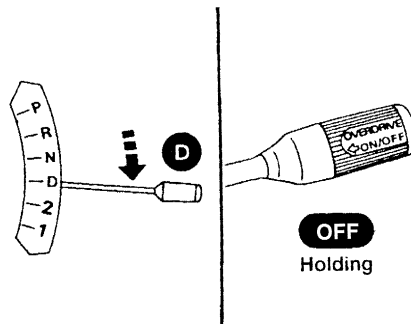

AAT156A

6. Turn ignition switch to OFF position.
7. Turn ignition switch to ON position (Do not start engine.)
8. Release the overdrive control switch (the O/D OFF indicator lamp will be OFF).
9. Wait 2 seconds.

▶ GO TO 3.

GI

MA

EM

LC

EC

FE

AT

AX

SU

BR

ST

RS

BT

HA

SC

EL

IDX

ON BOARD DIAGNOSTIC SYSTEM DESCRIPTION

Diagnostic Procedure Without CONSULT-II (Cont'd)

3 JUDGEMENT PROCEDURE STEP 2

1. Move selector lever to 2 position.

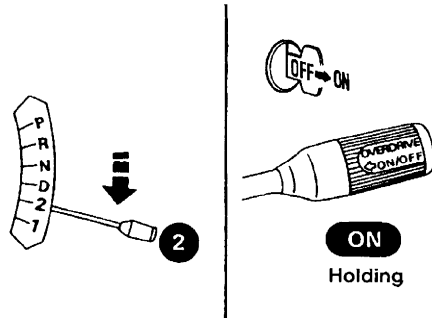

AAT157A

2. Depress and release overdrive control switch in ON position until next step is completed (the O/D OFF indicator lamp will be ON).

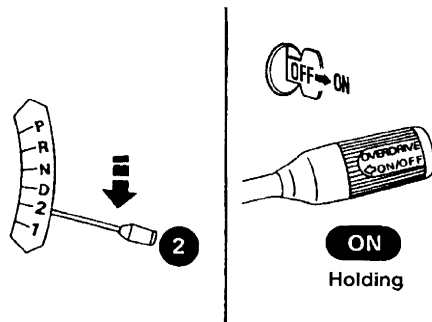

AAT157A

3. Depress and hold the overdrive control switch (the O/D OFF indicator lamp will be OFF) until directed to release the switch.



GO TO 4.

ON BOARD DIAGNOSTIC SYSTEM DESCRIPTION

Diagnostic Procedure Without CONSULT-II (Cont'd)

GI

MA

EM

LC

EC

FE

AT

AX

SU

BR

ST

RS

BT

HA

SC

EL

IDX

4 JUDGEMENT PROCEDURE STEP 3

1. Move selector lever to 1 position.
2. Release the overdrive control switch.

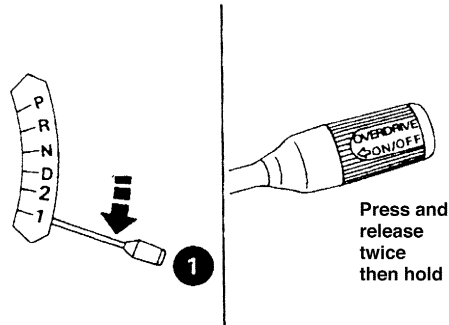

AAT158A

3. Depress and release the overdrive control switch (the O/D OFF indicator lamp will be ON).
4. Depress and release the overdrive control switch (the O/D OFF indicator lamp will be OFF).
5. Depress and hold the overdrive control switch (the O/D OFF indicator lamp will be ON) until directed to release the switch.

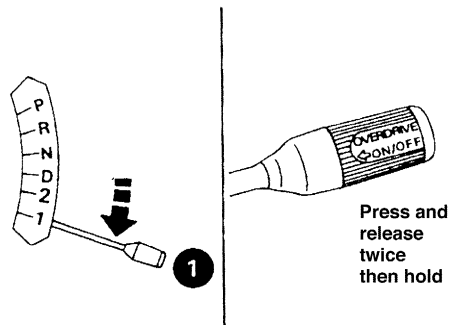

AAT158A

▶ GO TO 5.

5 JUDGEMENT PROCEDURE STEP 4

1. Depress accelerator pedal fully and release it.
2. Release the overdrive control switch (the O/D OFF indicator lamp will begin to flash ON and OFF).

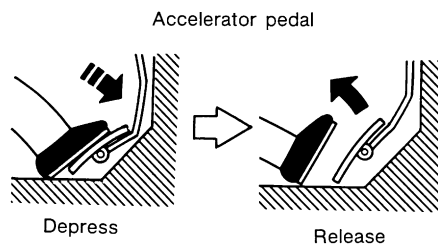



SAT981F

▶ GO TO 6.

ON BOARD DIAGNOSTIC SYSTEM DESCRIPTION

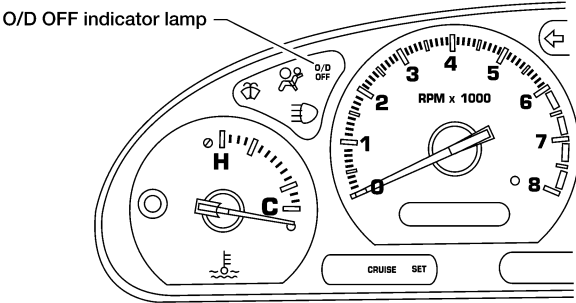
Diagnostic Procedure Without CONSULT-II (Cont'd)

6	CHECK SELF-DIAGNOSTIC CODE
<p>Check O/D OFF indicator lamp. Refer to "JUDGEMENT OF SELF-DIAGNOSIS CODE", AT-52.</p>	
	
LAT383	
	DIAGNOSIS END

JUDGEMENT OF SELF-DIAGNOSIS CODE

NDAT0216S04

O/D OFF indicator lamp:

All judgement flickers are the same.

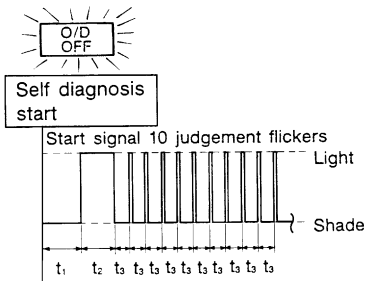

SAT436F

All circuits that can be confirmed by self-diagnosis are OK.

2nd judgement flicker is longer than others.

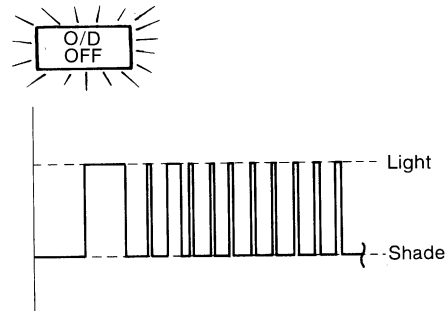

SAT439F

Vehicle speed sensor circuit is short-circuited or disconnected.
⇒ Go to **VEHICLE SPEED SENSOR-MTR, AT-205.**

1st judgement flicker is longer than others.

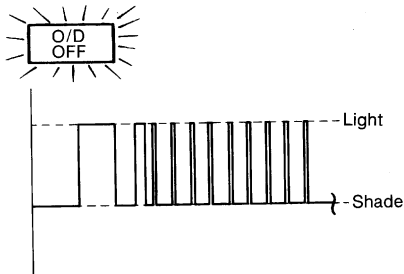

SAT437F

Revolution sensor circuit is short-circuited or disconnected.
⇒ Go to **VEHICLE SPEED SENSOR-A/T (REVOLUTION SENSOR) (DTC: 1102), AT-117.**

3rd judgement flicker is longer than others.

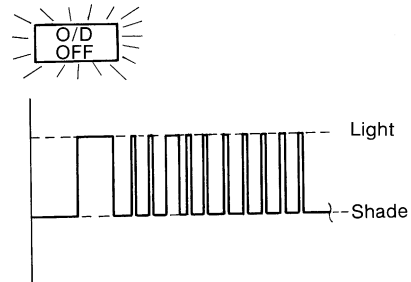

SAT441F

Throttle position sensor circuit is short-circuited or disconnected.
⇒ Go to **THROTTLE POSITION SENSOR (DTC: 1206), AT-185.**

ON BOARD DIAGNOSTIC SYSTEM DESCRIPTION

Diagnostic Procedure Without CONSULT-II (Cont'd)

O/D OFF indicator lamp:

4th judgement flicker is longer than others.

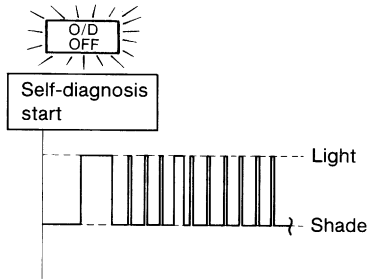

SAT443F

Shift solenoid valve A circuit is short-circuited or disconnected.
⇒ Go to **SHIFT SOLENOID VALVE A (DTC: 1108), AT-173.**

7th judgement flicker is longer than others.

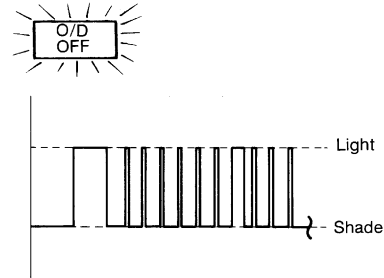

SAT449F

Torque converter clutch solenoid valve circuit is short-circuited or disconnected.
⇒ Go to **TORQUE CONVERTER CLUTCH SOLENOID VALVE (DTC: 1204), AT-154.**

5th judgement flicker is longer than others.

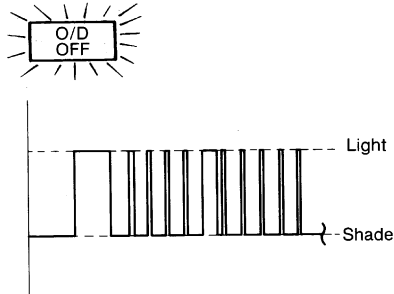

SAT445F

Shift solenoid valve B circuit is short-circuited or disconnected.
⇒ Go to **SHIFT SOLENOID VALVE B (DTC: 1201), AT-179.**

8th judgement flicker is longer than others.

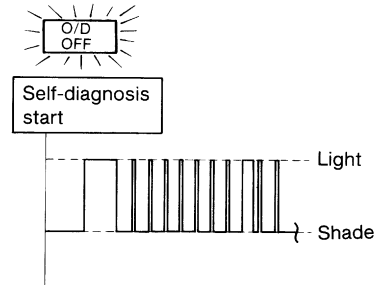

SAT451F

A/T fluid temperature sensor is disconnected or TCM power source circuit is damaged.
⇒ Go to **A/T FLUID TEMPERATURE SENSOR AND TCM POWER SOURCE, AT-198.**

6th judgement flicker is longer than others.

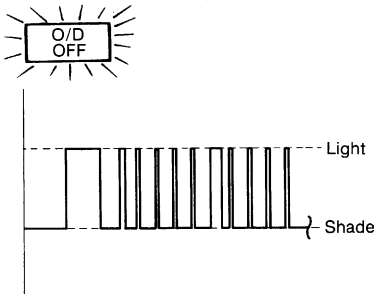

SAT447F

Overrun clutch solenoid valve circuit is short-circuited or disconnected.
⇒ Go to **OVERRUN CLUTCH SOLENOID VALVE (DTC: 1203), AT-192.**

9th judgement flicker is longer than others.

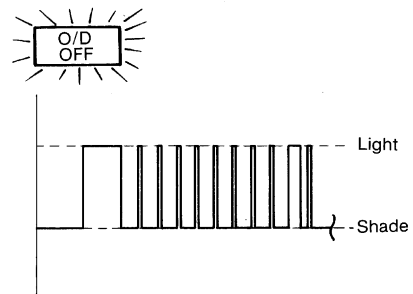

SAT453F

Engine speed signal circuit is short-circuited or disconnected.
⇒ Go to **ENGINE SPEED SIGNAL (DTC: 1207), AT-123.**

GI

MA

EM

LC

EC

FE

AT

AX

SU

BR

ST

RS

BT

HA

SC

EL

IDX

ON BOARD DIAGNOSTIC SYSTEM DESCRIPTION

Diagnostic Procedure Without CONSULT-II (Cont'd)

O/D OFF indicator lamp:

10th judgement flicker is longer than others.

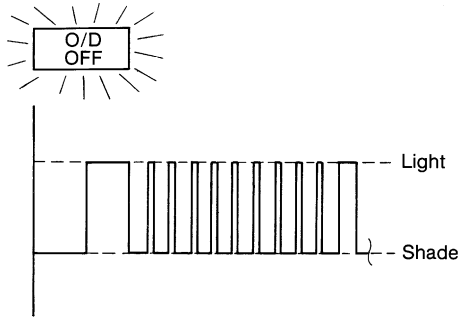

SAT455F

Line pressure solenoid valve circuit is short-circuited or disconnected.
 ⇒ Go to **LINE PRESSURE SOLENOID VALVE (DTC: 1205), AT-167.**

Lamp comes on.

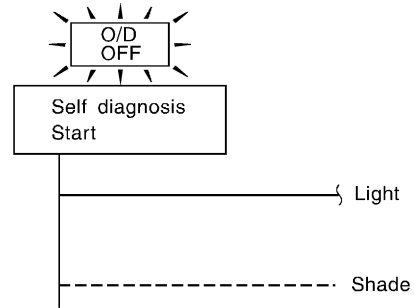

SAT367J

Park/neutral position (PNP) switch, overdrive control switch or throttle position switch circuit is disconnected or TCM is damaged.
 ⇒ Go to **21. TCM Self-diagnosis Does Not Activate (Park/neutral position (PNP), Overdrive Control and Throttle Position Switch Circuit Checks), AT-254.**

Flickers as shown below.

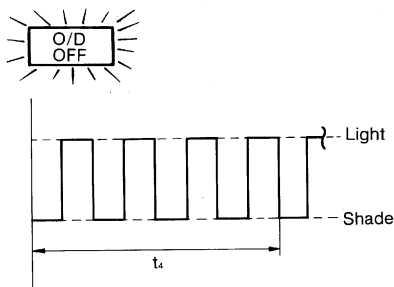

SAT457F

Battery power is low.
 Battery has been disconnected for a long time.
 Battery is connected conversely.
 (When reconnecting TCM connectors. — This is not a problem.)

$t_1 = 2.5$ seconds $t_2 = 2.0$ seconds $t_3 = 1.0$ second $t_4 = 1.0$ second

TROUBLE DIAGNOSIS — INTRODUCTION

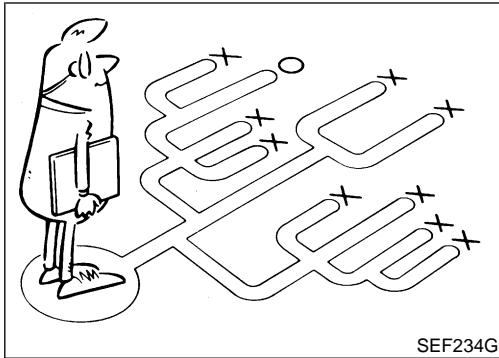
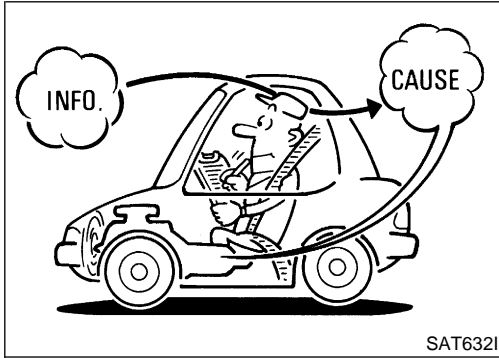
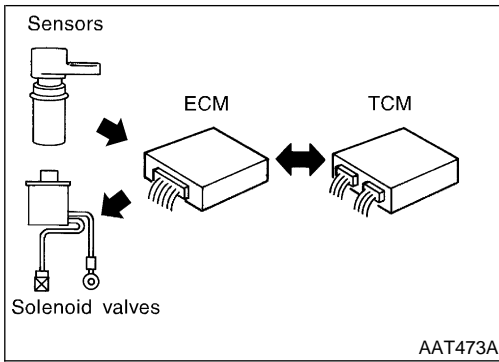

Introduction

The TCM receives a signal from the vehicle speed sensor, throttle position sensor or park/neutral position (PNP) switch and provides shift control or lock-up control via A/T solenoid valves. ^{NDAT0026}

The TCM also communicates with the ECM by means of a signal sent from sensing elements used with the OBD-related parts of the A/T system for malfunction-diagnostic purposes. The TCM is capable of diagnosing malfunctioning parts while the ECM can store malfunctions in its memory.

Input and output signals must always be correct and stable in the operation of the A/T system. The A/T system must be in good operating condition and be free of valve seizure, solenoid valve malfunction, etc.

It is much more difficult to diagnose a problem that occurs intermittently rather than continuously. Most intermittent problems are caused by poor electric connections or improper wiring. In this case, careful checking of suspected circuits may help prevent the replacement of good parts.

A visual check only, may not find the cause of the problems. A road test with CONSULT-II (or GST) or a circuit tester connected should be performed. Follow the "Work Flow". Refer to AT-59, "Work Flow". Before undertaking actual checks, take a few minutes to talk with a customer who approaches with a driveability complaint. The customer can supply good information about such problems, especially intermittent ones. Find out what symptoms are present and under what conditions they occur. A "DIAGNOSTIC WORKSHEET" like the example (AT-56) should be used.

Start your diagnosis by looking for "conventional" problems first. This will help troubleshoot driveability problems on an electronically controlled engine vehicle.

Also check related Service bulletins for information.

GI

MA

EM

LC

EC

FE

AT

AX

SU

BR

ST

RS

BT

HA

SC

EL

IDX

TROUBLE DIAGNOSIS — INTRODUCTION

Introduction (Cont'd)

Diagnostic Worksheet

=NDAT0026S0102

1.	<input type="checkbox"/> Read the Fail-safe and listen to customer complaints.	AT-8	GI		
2.	<input type="checkbox"/> CHECK A/T FLUID	AT-61	MA		
	<input type="checkbox"/> Leakage (Follow specified procedure) <input type="checkbox"/> Fluid condition <input type="checkbox"/> Fluid level				
3.	<input type="checkbox"/> Perform STALL TEST and PRESSURE TEST.	AT-61,65	EM		
	<input type="checkbox"/> Stall test — Mark possible damaged components/others.				
	<table border="1" style="width: 100%; border-collapse: collapse;"> <tr> <td style="width: 50%; vertical-align: top;"> <input type="checkbox"/> Torque converter one-way clutch <input type="checkbox"/> Reverse clutch <input type="checkbox"/> Forward clutch <input type="checkbox"/> Overrun clutch <input type="checkbox"/> Forward one-way clutch </td> <td style="width: 50%; vertical-align: top;"> <input type="checkbox"/> Low & reverse brake <input type="checkbox"/> Low one-way clutch <input type="checkbox"/> Engine <input type="checkbox"/> Line pressure is low <input type="checkbox"/> Clutches and brakes except high clutch and brake band are OK </td> </tr> </table>			<input type="checkbox"/> Torque converter one-way clutch <input type="checkbox"/> Reverse clutch <input type="checkbox"/> Forward clutch <input type="checkbox"/> Overrun clutch <input type="checkbox"/> Forward one-way clutch	<input type="checkbox"/> Low & reverse brake <input type="checkbox"/> Low one-way clutch <input type="checkbox"/> Engine <input type="checkbox"/> Line pressure is low <input type="checkbox"/> Clutches and brakes except high clutch and brake band are OK
	<input type="checkbox"/> Torque converter one-way clutch <input type="checkbox"/> Reverse clutch <input type="checkbox"/> Forward clutch <input type="checkbox"/> Overrun clutch <input type="checkbox"/> Forward one-way clutch			<input type="checkbox"/> Low & reverse brake <input type="checkbox"/> Low one-way clutch <input type="checkbox"/> Engine <input type="checkbox"/> Line pressure is low <input type="checkbox"/> Clutches and brakes except high clutch and brake band are OK	
<input type="checkbox"/> Pressure test — Suspected parts:					
4.	<input type="checkbox"/> Perform all ROAD TEST and mark required procedures.	AT-66	AT		
4-1.	Check before engine is started.	AT-67	AX		
	<input type="checkbox"/> SELF-DIAGNOSTIC PROCEDURE - Mark detected items.				
4-2.	Check at idle	AT-68	HA		
	<input type="checkbox"/> 1. O/D OFF Indicator Lamp Does Not Come On, AT-216. <input type="checkbox"/> 2. Engine Cannot Be Started In P and N Position, AT-218. <input type="checkbox"/> 3. In P Position, Vehicle Moves Forward or Backward When Pushed, AT-219. <input type="checkbox"/> 4. In N Position, Vehicle Moves, AT-220. <input type="checkbox"/> 5. Large Shock. N → R Position, AT-222. <input type="checkbox"/> 6. Vehicle Does Not Creep Backward In R Position, AT-224. <input type="checkbox"/> 7. Vehicle Does Not Creep Forward In D, 2 or 1 Position, AT-228.				

TROUBLE DIAGNOSIS — INTRODUCTION

Introduction (Cont'd)

4.	4-3.	Cruise test	AT-71 AT-74
		Part-1	
		<input type="checkbox"/> 8. Vehicle Cannot Be Started From D ₁ , AT-231. <input type="checkbox"/> 9. A/T Does Not Shift: D ₁ → D ₂ or Does Not Kickdown: D ₄ → D ₂ , AT-234. <input type="checkbox"/> 10. A/T Does Not Shift: D ₂ →D ₃ , AT-237. <input type="checkbox"/> 11. A/T Does Not Shift: D ₃ →D ₄ , AT-240. <input type="checkbox"/> 12. A/T Does Not Perform Lock-up, AT-243. <input type="checkbox"/> 13. A/T Does Not Hold Lock-up Condition, AT-245. <input type="checkbox"/> 14. Lock-up Is Not Released, AT-247. <input type="checkbox"/> 15. Engine Speed Does Not Return To Idle (Light Braking D ₄ → D ₃), AT-248.	
		Part-2	AT-78
		<input type="checkbox"/> 16. Vehicle Does Not Start From D ₁ , AT-250. <input type="checkbox"/> 9. A/T Does Not Shift: D ₁ → D ₂ or Does Not Kickdown: D ₄ → D ₂ , AT-234. <input type="checkbox"/> 10. A/T Does Not Shift: D ₂ →D ₃ , AT-237. <input type="checkbox"/> 11. A/T Does Not Shift: D ₃ →D ₄ , AT-240.	
		Part-3	AT-80
		<input type="checkbox"/> 17. A/T Does Not Shift: D ₄ →D ₃ When Overdrive Control Switch ON → OFF, AT-251. <input type="checkbox"/> 15. Engine Speed Does Not Return To Idle (Engine Brake In D ₃), AT-248. <input type="checkbox"/> 18. A/T Does Not Shift: D ₃ →2 ₂ , When Selector Lever D → 2 Position, AT-252. <input type="checkbox"/> 15. Engine Speed Does Not Return To Idle (Engine Brake In 2 ₂), AT-248. <input type="checkbox"/> 19. A/T Does Not Shift: 2 ₂ →1 ₁ , When Selector Lever 2 → 1 Position, AT-253. <input type="checkbox"/> 20. Vehicle Does Not Decelerate By Engine Brake, AT-254. <input type="checkbox"/> SELF-DIAGNOSTIC PROCEDURE — Mark detected items.	
		<input type="checkbox"/> Park/neutral position (PNP) switch, AT-103. <input type="checkbox"/> A/T fluid temperature sensor, AT-110. <input type="checkbox"/> Vehicle speed sensor-A/T (Revolution sensor), AT-117. <input type="checkbox"/> Engine speed signal, AT-123. <input type="checkbox"/> Torque converter clutch solenoid valve, AT-154. <input type="checkbox"/> Line pressure solenoid valve, AT-167. <input type="checkbox"/> Shift solenoid valve A, AT-178. <input type="checkbox"/> Shift solenoid valve B, AT-179. <input type="checkbox"/> Throttle position sensor, AT-185. <input type="checkbox"/> Overrun clutch solenoid valve, AT-192. <input type="checkbox"/> Park/neutral position (PNP), overdrive control and throttle position switches, AT-254. <input type="checkbox"/> A/T fluid temperature sensor and TCM power source, AT-198. <input type="checkbox"/> Vehicle speed sensor-MTR, AT-205. <input type="checkbox"/> Control Unit (RAM) Control Unit (ROM), AT-209 <input type="checkbox"/> Control Unit (EEPROM), AT-211 <input type="checkbox"/> Battery <input type="checkbox"/> Others	
5.		<input type="checkbox"/> For self-diagnosis NG items, inspect each component. Repair or replace the damaged parts.	AT-40
6.		<input type="checkbox"/> Perform all ROAD TEST and re-mark required procedures.	AT-66
7.		<input type="checkbox"/> Perform DTC CONFIRMATION PROCEDURE for following MIL indicating items and check out NG items. Refer to EC-51 , "Emission-related Diagnostic Information".	EC section
		<input type="checkbox"/> DTC (P0731, 1103) A/T 1st gear function, AT-127. <input type="checkbox"/> DTC (P0732, 1104) A/T 2nd gear function, AT-133. <input type="checkbox"/> DTC (P0733, 1105) A/T 3rd gear function, AT-139. <input type="checkbox"/> DTC (P0734, 1106) A/T 4th gear function, AT-145. <input type="checkbox"/> DTC (P0744, 1107) A/T TCC S/V function (lock-up), AT-159.	
8.		<input type="checkbox"/> Perform the Diagnostic Procedures for all remaining items marked NG. Repair or replace the damaged parts. Refer to the Symptom Chart when you perform the procedures. (The chart also shows some other possible symptoms and the component inspection orders.)	AT-83 AT-96
9.		<input type="checkbox"/> Erase DTC from TCM and ECM memories.	AT-37

Work Flow

HOW TO PERFORM TROUBLE DIAGNOSES FOR QUICK AND ACCURATE REPAIR

NDAT0027

NDAT0027S01

A good understanding of the malfunction conditions can make troubleshooting faster and more accurate.

In general, each customer feels differently about a problem. It is important to fully understand the symptoms or conditions for a customer complaint.

Make good use of the two sheets provided, "Information from Customer" (AT-56) and "Diagnostic Worksheet" (AT-57), to perform the best troubleshooting possible.

GI

MA

EM

LC

EC

FE

AT

AX

SU

BR

ST

RS

BT

HA

SC

EL

IDX

TROUBLE DIAGNOSIS — INTRODUCTION

Work Flow (Cont'd)

WORK FLOW CHART

=NDAT0027S02

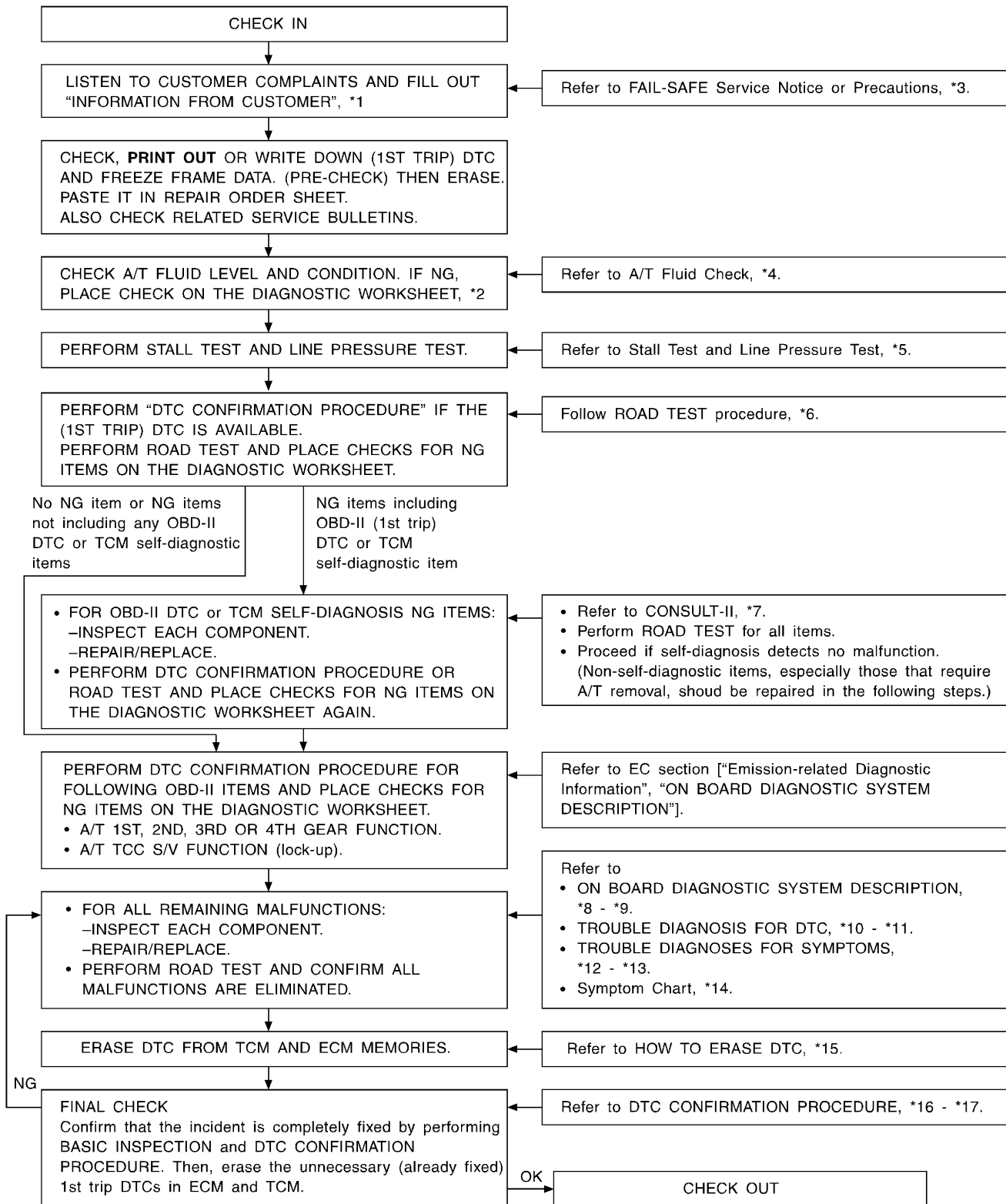

WAT419

*1: AT-56

*2: AT-57

*3: AT-8

*4: AT-61

*5: AT-61, 65

*6: AT-66

*7: AT-39

*8: AT-35

*9: AT-52

*10: AT-103

*11: AT-211

*12: AT-216

*13: AT-254

*14: AT-83

*15: AT-37

*16: AT-104

*17: AT-211

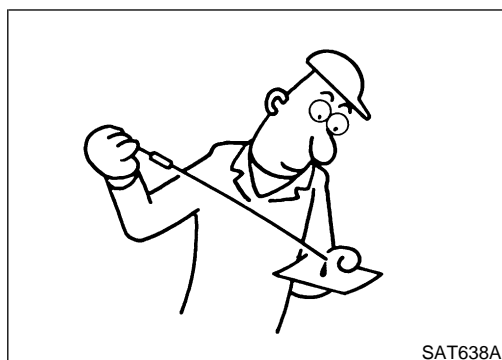
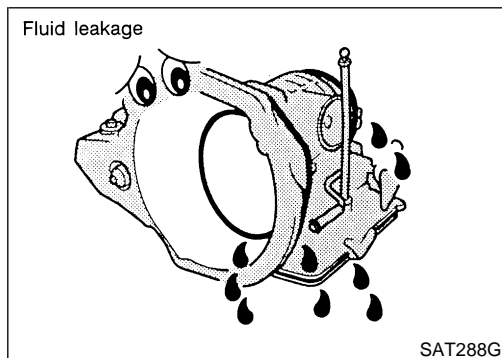
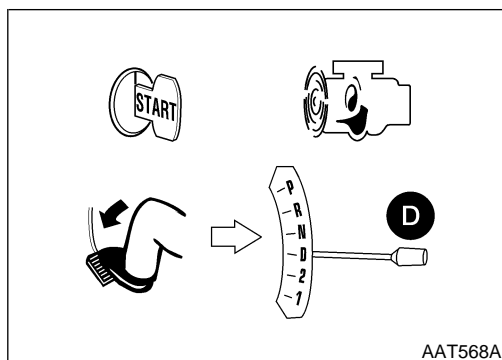

A/T Fluid Check

NDAT0028

FLUID LEAKAGE CHECK

NDAT0028S01

1. Clean area suspected of leaking. — for example, mating surface of converter housing and transmission case.
2. Start engine, apply foot brake, place selector lever in D position and wait a few minutes.
3. Stop engine.

4. Check for fresh leakage.

FLUID CONDITION CHECK

NDAT0028S02

Fluid color	Suspected problem
Dark or black with burned odor	Wear of frictional material
Milky pink	Water contamination — Road water entering through filler tube or breather
Varnished fluid, light to dark brown and tacky	Oxidation — Over or under filling, — Overheating

FLUID LEVEL CHECK

NDAT0028S03

Refer to **MA-24** "Checking A/T Fluid".

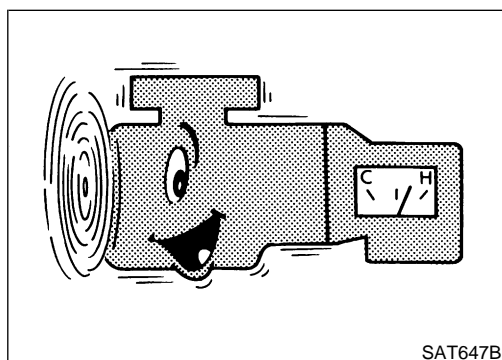

Stall Test

NDAT0029

STALL TEST PROCEDURE

NDAT0029S01

1. Check A/T fluid and engine oil levels. If necessary, add fluid and oil.
2. Drive vehicle for approx. 10 minutes or until fluid and oil reach operating temperature.

ATF operating temperature:
50 - 80°C (122 - 176°F)

GI

MA

EM

LC

EC

FE

AT

AX

SU

BR

ST

RS

BT

HA

SC

EL

IDX

TROUBLE DIAGNOSIS — BASIC INSPECTION

Stall Test (Cont'd)

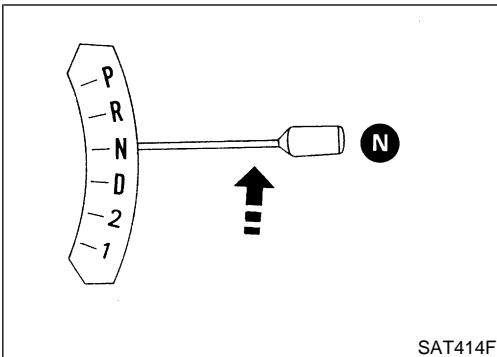
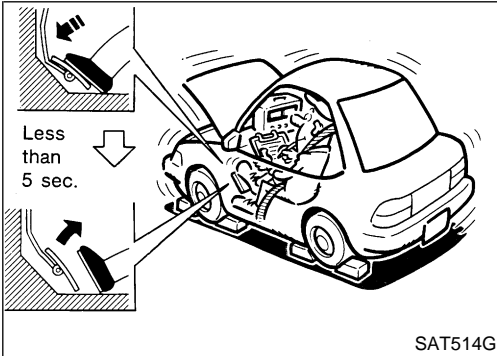
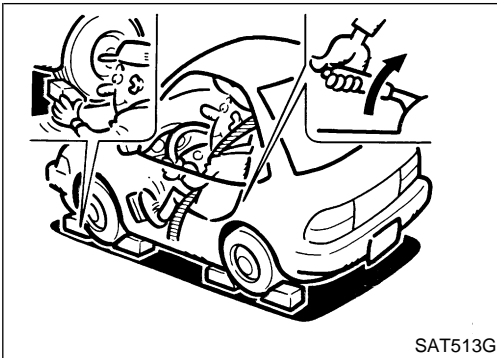

3. Set parking brake and block wheels.
4. Install a tachometer where it can be seen by driver during test.
 - **It is good practice to mark the point of specified engine rpm on indicator.**
5. Start engine, apply foot brake, and place selector lever in D position.
6. Accelerate to wide-open throttle gradually while applying foot brake.
7. Quickly note the engine stall revolution and immediately release throttle.
 - **During test, never hold throttle wide-open for more than 5 seconds.**
Stall revolution:
1,900 - 2,200 rpm
8. Move selector lever to N position.
9. Cool off ATF.
 - **Run engine at idle for at least one minute.**
10. Repeat steps 5 through 9 with selector lever in 2, 1 and R positions.

JUDGEMENT OF STALL TEST

The test result and possible damaged components relating to each result are shown in the illustrations on next page.

In order to pinpoint the possible damaged components, follow the "WORK FLOW CHART" shown in AT-60.

NOTE:

Stall revolution is too high in D, 2 or 1 position:

- Slippage occurs in 1st gear but not in 2nd and 3rd gears. Low one-way clutch slippage
- Slippage occurs in the following gears:
1st through 3rd gears in D position and engine brake functions with overdrive control switch set to OFF.
1st and 2nd gears in 2 position and engine brake functions with accelerator pedal released (fully closed throttle). Forward clutch or forward one-way clutch slippage

Stall revolution is too high in R position:

- Engine brake does not function in 1 position. Low & reverse brake slippage
- Engine brake functions in 1 position. Reverse clutch slippage

Stall revolution within specifications:

- Vehicle does not achieve speed of more than 80 km/h (50

TROUBLE DIAGNOSIS — BASIC INSPECTION

Stall Test (Cont'd)

MPH). One-way clutch seizure in torque converter housing

CAUTION:

Be careful since automatic fluid temperature increases abnormally.

- Slippage occurs in 3rd and 4th gears in D position. High clutch slippage
- Slippage occurs in 2nd and 4th gear in D position. Brake band slippage
- Engine brake does not function in 2nd and 3rd gears in D position, 2nd gear in 2 position, and 1st gear in 1 position with overdrive control switch set to OFF.

Stall revolution less than specifications:

- Poor acceleration during starts. One-way clutch seizure in torque converter

GI

MA

EM

LC

EC

FE

AT

AX

SU

BR

ST

RS

BT

HA

SC

EL

IDX

TROUBLE DIAGNOSIS — BASIC INSPECTION

Stall Test (Cont'd)

Selector lever position	Judgement		
	H	O	L
D	H	O	L
2	H	O	L
1	H	O	L
R	O	H	L

O : Stall revolution is normal.
 H : Stall revolution is higher than specified.
 L : Stall revolution is lower than specified.

Damaged components

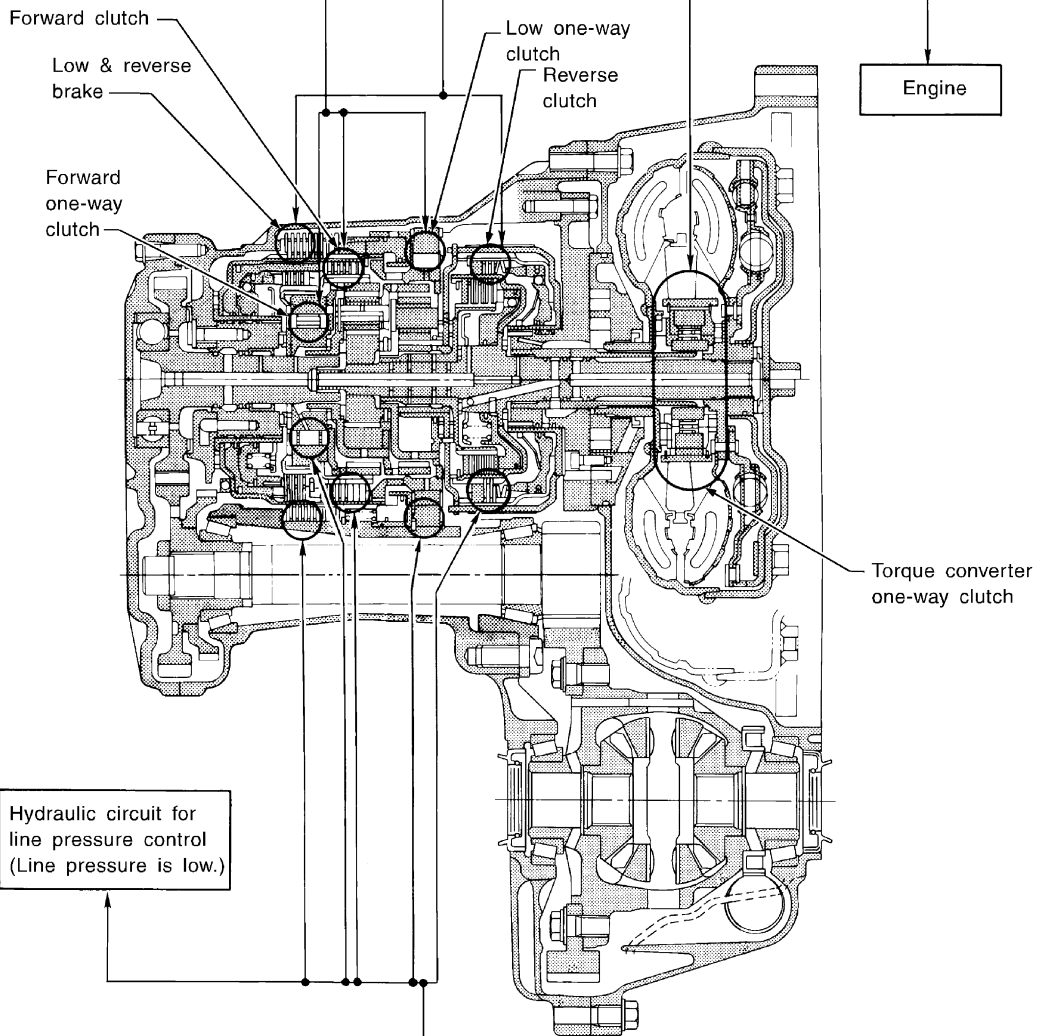

Hydraulic circuit for line pressure control (Line pressure is low.)

Clutches and brakes except high clutch, brake band and overrun clutch are OK. (Condition of high clutch, brake band and overrun clutch cannot be confirmed by stall test.)

D	H	O
2	H	O
1	H	O
R	H	O
Selector lever position	Judgement	

SAT9071

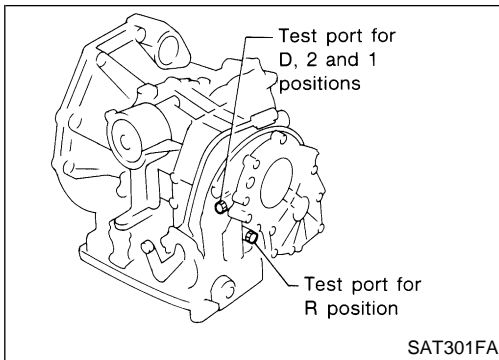

Line Pressure Test

LINE PRESSURE TEST PORTS

Location of line pressure test ports are shown in the illustration.

- Always replace pressure plugs as they are self-sealing bolts.

NDAT0030

NDAT0030S01

GI

MA

EM

LC

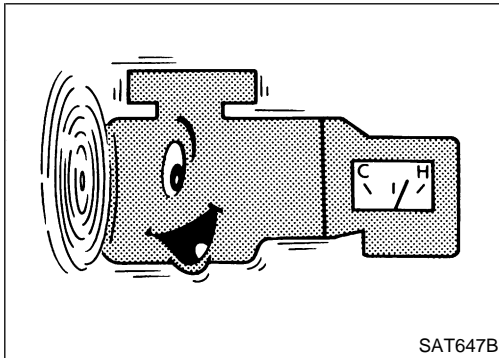

LINE PRESSURE TEST PROCEDURE

1. Check A/T fluid and engine oil levels. If necessary, add fluid and oil.
2. Drive vehicle for approx. 10 minutes or until fluid and oil reach operating temperature.

ATF operating temperature:
50 - 80°C (122 - 176°F)

NDAT0030S02

EC

FE

AT

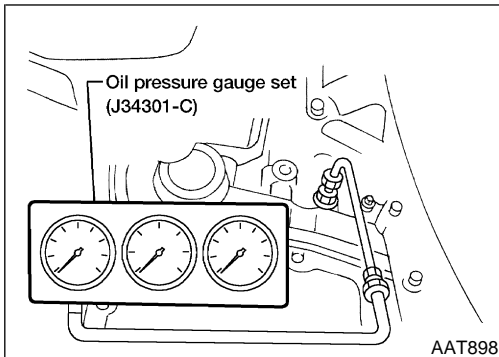

3. Install pressure gauge to corresponding line pressure port.

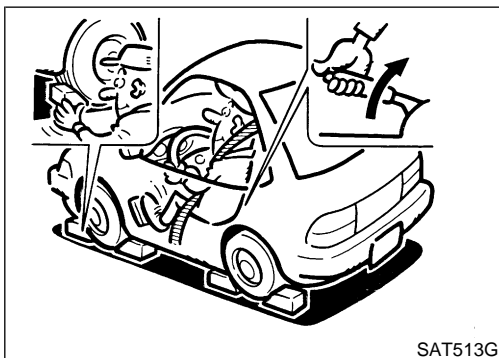

4. Set parking brake and block wheels.
 - Continue to depress brake pedal fully while line pressure test is being performed at stall speed.

AX

SU

BR

ST

RS

BT

HA

SC

EL

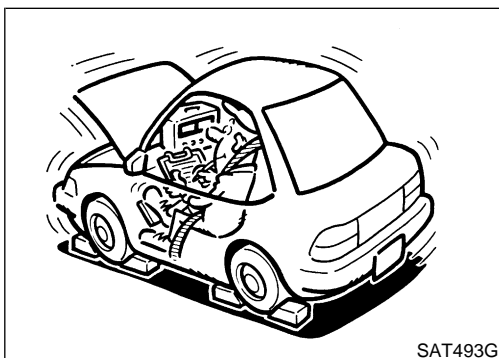

5. Start engine and measure line pressure at idle and stall speed.
 - When measuring line pressure at stall speed, follow the stall test procedure.

Line pressure: Refer to “Line Pressure”, AT-370.

IDX

TROUBLE DIAGNOSIS — BASIC INSPECTION

Line Pressure Test (Cont'd)

JUDGEMENT OF LINE PRESSURE TEST

NDAT0030S03

	Judgement	Suspected parts
At idle	Line pressure is low in all positions.	<ul style="list-style-type: none"> ● Oil pump wear ● Control piston damage ● Pressure regulator valve or plug sticking ● Spring for pressure regulator valve damaged ● Fluid pressure leakage between oil strainer and pressure regulator valve ● Clogged strainer
	Line pressure is low in particular position.	<ul style="list-style-type: none"> ● Fluid pressure leakage between manual valve and particular clutch ● For example, line pressure is: <ul style="list-style-type: none"> – Low in R and 1 positions, but – Normal in D and 2 positions. Therefore, fluid leakage exists at or around low and reverse brake circuit. Refer to "CLUTCH AND BRAKE CHART", AT-19.
	Line pressure is high.	<ul style="list-style-type: none"> ● Maladjustment of throttle position sensor ● A/T fluid temperature sensor damaged ● Line pressure solenoid valve sticking ● Short circuit of line pressure solenoid valve circuit ● Pressure modifier valve sticking ● Pressure regulator valve or plug sticking ● Open in dropping resistor circuit
At stall speed	Line pressure is low.	<ul style="list-style-type: none"> ● Maladjustment of throttle position sensor ● Line pressure solenoid valve sticking ● Short circuit of line pressure solenoid valve circuit ● Pressure regulator valve or plug sticking ● Pressure modifier valve sticking ● Pilot valve sticking

ROAD TEST PROCEDURE

1. Check before engine is started.



2. Check at idle.



3. Cruise test.

SAT786A

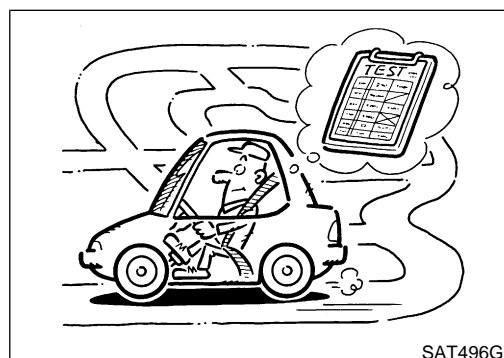

SAT496G

Road Test DESCRIPTION

NDAT0031

NDAT0031S01

- The purpose of the test is to determine overall performance of A/T and analyze causes of problems.
- The road test consists of the following three parts:
 1. Check before engine is started
 2. Check at idle
 3. Cruise test
- Before road test, familiarize yourself with all test procedures and items to check.
- Conduct tests on all items until specified symptom is found. Troubleshoot items which check out No Good after road test. Refer to "ON BOARD DIAGNOSTIC SYSTEM DESCRIPTION" and "TROUBLE DIAGNOSES FOR SYMPTOMS", AT-35 to AT-52 and AT-216 to AT-254.

TROUBLE DIAGNOSIS — BASIC INSPECTION

Road Test (Cont'd)

1. CHECK BEFORE ENGINE IS STARTED

=NDAT0031S02

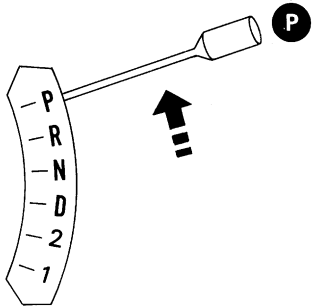
1	CHECK O/D OFF INDICATOR LAMP	<p>1. Park vehicle on flat surface. 2. Move selector lever to P position.</p> <div style="text-align: center;">  </div> <p>3. Turn ignition switch to OFF position. Wait at least 5 seconds. 4. Turn ignition switch to ON position. (Do not start engine.) 5. Does O/D OFF indicator lamp come on for about 2 seconds?</p> <p style="text-align: center;">Yes or No</p>	<p>SAT408F</p>
Yes		▶ GO TO 2.	
No		▶ Stop ROAD TEST. Go to "1. O/D OFF Indicator Lamp Does Not Come On", AT-216.	

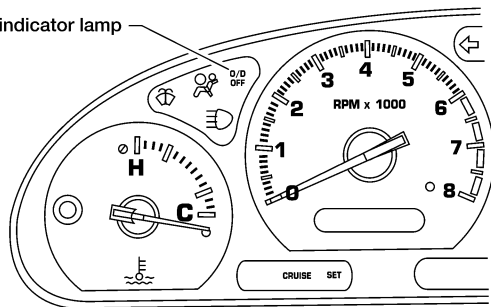
2	CHECK O/D OFF INDICATOR LAMP	<p>Does O/D OFF indicator lamp flicker for about 8 seconds?</p> <div style="text-align: center;">  </div> <p style="text-align: center;">Yes or No</p>	<p>LAT383</p>
Yes		▶ Perform self-diagnosis and check NG items on the DIAGNOSTIC WORKSHEET, AT-56. Refer to TCM SELF-DIAGNOSTIC PROCEDURE (NO TOOLS), AT-48.	
No		▶ <ul style="list-style-type: none"> 1. Turn ignition switch to OFF position. 2. Perform self-diagnosis and note NG items. Refer to TCM SELF-DIAGNOSTIC PROCEDURE (NO TOOLS), AT-48. 3. Go to "2. CHECK AT IDLE", AT-68. 	

GI
MA
EM
LC
EC
FE
AT
AX
SU
BR
ST
RS
BT
HA
SC
EL
IDX

TROUBLE DIAGNOSIS — BASIC INSPECTION

Road Test (Cont'd)

2. CHECK AT IDLE

NDAT0031S03

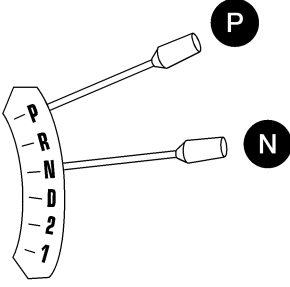
1	CHECK ENGINE START	
<p>1. Park vehicle on flat surface. 2. Move selector lever to P position.</p> <div style="text-align: center;">  </div>		
<p>3. Turn ignition switch to OFF position. 4. Turn ignition switch to START position. 5. Is engine started?</p> <p style="text-align: right;">AAT579A</p>		
Yes or No		
Yes	▶	GO TO 2.
No	▶	Mark the box on the DIAGNOSTIC WORKSHEET. Go to "2. Engine Cannot Be Started In P and N Position", AT-218. Continue ROAD TEST.

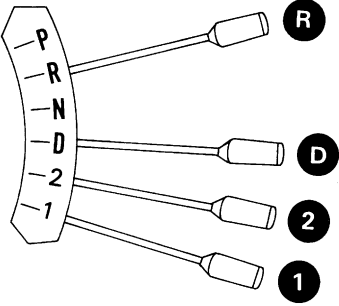
2	CHECK ENGINE START	
<p>1. Turn ignition switch to ACC position. 2. Move selector lever to D, 1, 2 or R position.</p> <div style="text-align: center;">  </div>		
<p>3. Turn ignition switch to START position. 4. Is engine started?</p> <p style="text-align: right;">SAT412F</p>		
Yes or No		
Yes	▶	Mark the box on the DIAGNOSTIC WORKSHEET. Mark the box on the DIAGNOSTIC WORKSHEET. Go to "2. Engine Cannot Be Started In P and N Position", AT-218. Continue ROAD TEST.
No	▶	GO TO 3.

TROUBLE DIAGNOSIS — BASIC INSPECTION

Road Test (Cont'd)

GI

MA

EM

LC

EC

FE

AT

AX

SU

BR

ST

RS

BT

HA

SC

EL

IDX

3 CHECK VEHICLE MOVE

1. Move selector lever to P position.

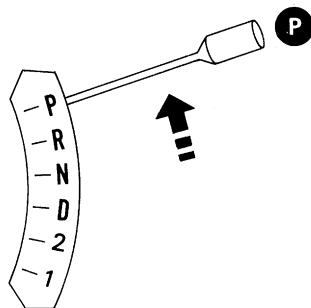

SAT408F

2. Turn ignition switch to OFF position.
3. Release parking brake.
4. Push vehicle forward or backward.

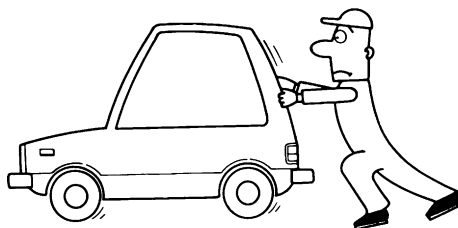

SAT796A

5. Does vehicle move when it is pushed forward or backward?
6. Apply parking brake.

Yes or No

Yes	▶	Mark the box on the DIAGNOSTIC WORKSHEET. Go to "3. In P Position, Vehicle Moves Forward Or Backward When Pushed", AT-219. Continue ROAD TEST.
No	▶	GO TO 4.

4 CHECK VEHICLE MOVE

1. Start engine.
2. Move selector lever to N position.

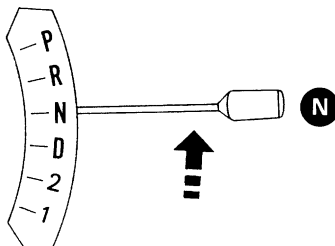

SAT414F

3. Release parking brake.
4. Does vehicle move forward or backward?

Yes or No

Yes	▶	Mark the box on the DIAGNOSTIC WORKSHEET. Go to "4. In N Position, Vehicle Moves", AT-220. Continue ROAD TEST.
No	▶	GO TO 5.

TROUBLE DIAGNOSIS — BASIC INSPECTION

Road Test (Cont'd)

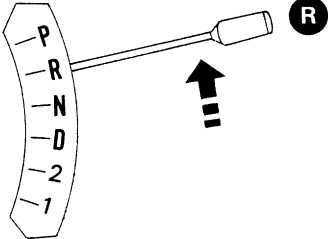
5	CHECK SHIFT LOCK	
1. Apply foot brake.		
		
2. Move selector lever to R position.		
		
3. Is there large shock when changing from N to R position?		
Yes or No		
Yes	▶	Mark the box on the DIAGNOSTIC WORKSHEET. Go to "5. Large Shock N → R Position", AT-222. Continue ROAD TEST.
No	▶	GO TO 6.

SAT797A

SAT416F

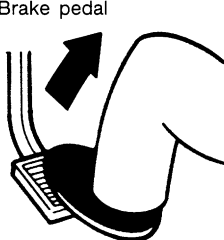
6	CHECK VEHICLE MOVE	
1. Release foot brake for several seconds.		
		
For several seconds		
2. Does vehicle creep backward when foot brake is released?		
Yes or No		
Yes	▶	GO TO 7.
No	▶	Mark the box on the DIAGNOSTIC WORKSHEET. Go to "6. Vehicle Does Not Creep Backward In R Position", AT-224. Continue ROAD TEST.

SAT799A

TROUBLE DIAGNOSIS — BASIC INSPECTION

Road Test (Cont'd)

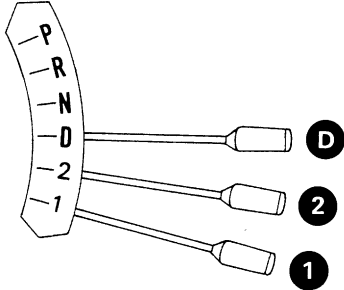
7	CHECK VEHICLE MOVE	
<p>1. Move selector lever to D, 2 and 1 positions and check if vehicle creeps forward.</p> <div style="text-align: center;">  </div>		
<p>2. Does vehicle creep forward in all three positions?</p> <p style="text-align: right;">SAT418F</p>		
Yes or No		
Yes	▶	Go to 3. CRUISE TEST, AT-71.
No	▶	Mark the box on the DIAGNOSTIC WORKSHEET. Go to "7. Vehicle Does Not Creep Forward In D, 2 Or 1 Position", AT-228. Continue ROAD TEST.

GI
MA
EM
LC
EC
FE
AT

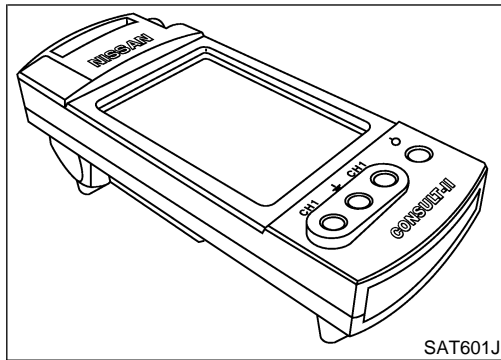

3. CRUISE TEST

- Check all items listed in Parts 1 through 3.

NDAT0031S04

With CONSULT-II

- Using CONSULT-II, conduct a cruise test and record the result.
- Print the result and ensure that shifts and lock-ups take place as per Shift Schedule.

NDAT0031S0401

AX
SU
BR
ST
RS

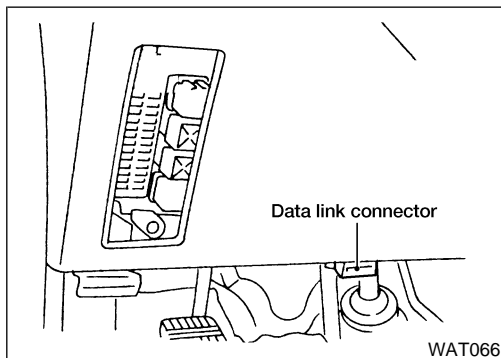

CONSULT-II Setting Procedure

1. Turn ignition switch OFF.
2. Connect CONSULT-II to data link connector. Data link connector for CONSULT-II is located in left side dash panel lower.

NDAT0031S0402

BT
HA
SC

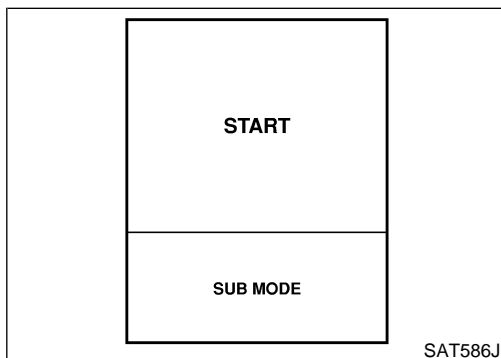

3. Turn ignition switch ON.
4. Touch "START".

EL
IDX

TROUBLE DIAGNOSIS — BASIC INSPECTION

Road Test (Cont'd)

SELECT SYSTEM
A/T
ENGINE

SAT014K

5. Touch "A/T".

SELECT DIAG MODE
SELF-DIAG RESULTS
DATA MONITOR
DTC WORK SUPPORT
TCM PART NUMBER

SAT971J

6. Touch "DATA MONITOR".

DATA MONITOR
SELECT MONITOR ITEM
TCM INPUT SIGNALS
MAIN SIGNAL
SELECTION FROM MENU

SAT175K

7. Touch "MAIN SIGNALS" or "TCM INPUT SIGNALS".

8. See "NUMERICAL DISPLAY", "BARCHART DISPLAY" or "LINE GRAPH DISPLAY".

SET RECORDING CONDITION
AUTO TRIG
MANU TRIG
TRIGGER POINT
<< [Progress Bar] >>
0% 20% 40% 60% 80% 100%
Recording Speed
MIN MAX
<< [Progress Bar] >>
/64 /32 /16 /8 /4 /2 FULL

SAT973J

9. Touch "SETTING" to recording condition ("AUTO TRIG" or "MANU TRIG") and touch "BACK".

10. Touch "START".

DATA MONITOR	
MONITOR	NO DTC
ENGINE SPEED	XXX rpm
GEAR	XXX
SLCT LVR POSI	N/P
VEHICLE SPEED	XXX km/h
THROTTLE POSI	XXX
LINE PRES DTY	XX%
TCC S/V DUTY	XX%
SHIFT S/V A	XX
SHIFT S/V B	XX

SAT134K

11. When performing cruise test, touch "RECORD".

TROUBLE DIAGNOSIS — BASIC INSPECTION

Road Test (Cont'd)

DATA MONITOR		
Recording Data	X%	DTC
		DETECTED
ENGINE SPEED	XXX	rpm
GEAR	XXX	
SLCT LVR POSI	N/P	
VEHICLE SPEED	XXX	km/h
THROTTLE POSI	XXX	
LINE PRES DTY	XX%	
TCC S/V DUTY	XX%	
SHIFT S/V A	XX	
SHIFT S/V B	XX	

SAT135K

12. After finishing cruise test part 1, touch "STOP".

REAL-TIME DIAG	
ENG SPEED SIG	

SAT987J

13. Touch "STORE" and touch "BACK".

STORE	
SYSTEM	SAVE REC DATA

SAT974J

Trigger	VHCL S/SEN A/T	VHCL S/SEN MTR	THRTL POSI SEN
	km/h	km/h	V

SAT975J

- 14. Touch "DISPLAY".
- 15. Touch "PRINT".
- 16. Check the monitor data printed out.
- 17. Continue cruise test part 2 and 3.

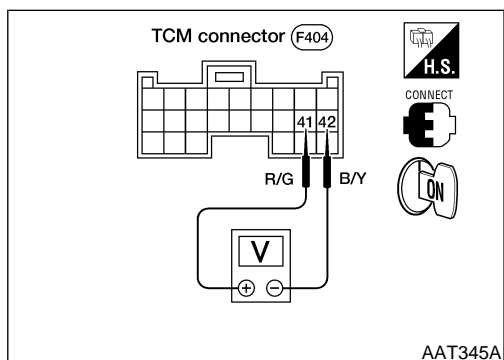

- Without CONSULT-II
 - Throttle position sensor can be checked by voltage across terminals 41 and 42 of TCM.
- NDAT0031S0403

GI
MA
EM
LC
EC
FE
AT
AX
SU
BR
ST
RS
BT
HA
SC
EL
IDX

TROUBLE DIAGNOSIS — BASIC INSPECTION

Road Test (Cont'd)

Cruise Test — Part 1

=NDAT0031S0404

1 CHECK STARTING GEAR (D₁) POSITION

1. Drive vehicle for approx. 10 minutes to warm engine oil and ATF up to operating temperature.

ATF operating temperature:

50 - 80°C (122 - 176°F)

2. Park vehicle on flat surface.
3. Set overdrive control switch to ON position.
4. Move selector lever to P position.

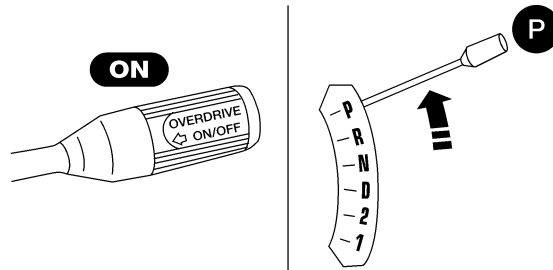

AAT569A

5. Start engine.
6. Move selector lever to D position.

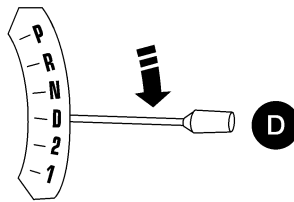

AAT570A

7. Accelerate vehicle by constantly depressing accelerator pedal half-way.

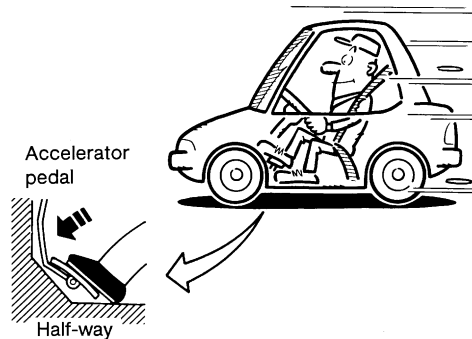

SAT495G

8. Does vehicle start from D₁?

Read gear position.

Yes or No

Yes



GO TO 2.

No



Go to "8. Vehicle Cannot Be Started From D₁", AT-231. Continue ROAD TEST.

TROUBLE DIAGNOSIS — BASIC INSPECTION

Road Test (Cont'd)

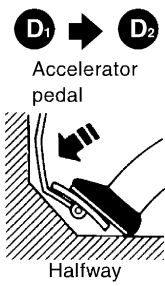
2	CHECK SHIFT UP (D₁ TO D₂)		
Does A/T shift from D ₁ to D ₂ at the specified speed? <input type="checkbox"/> Read gear position, throttle opening and vehicle speed. Specified speed when shifting from D ₁ to D ₂ : Refer to Shift schedule, AT-370.			
			
SAT954I			
Yes or No			
Yes	▶	GO TO 3.	
No	▶	Go to "9. A/T Does Not Shift: D ₁ → D ₂ Or Does Not Kickdown: D ₄ → D ₂ ", AT-234. Continue ROAD TEST.	

GI
 MA
 EM
 LC
 EC
 FE

AT

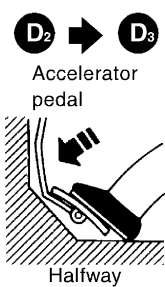
3	CHECK SHIFT UP (D₂ TO D₃)		
Does A/T shift from D ₂ to D ₃ at the specified speed? <input type="checkbox"/> Read gear position, throttle position and vehicle speed. Specified speed when shifting from D ₂ to D ₃ : Refer to Shift schedule, AT-370.			
			
SAT955I			
Yes or No			
Yes	▶	GO TO 4.	
No	▶	Go to "10. A/T Does Not Shift: D ₂ → D ₃ ", AT-237. Continue ROAD TEST.	

AX
 SU
 BR
 ST
 RS
 BT

HA

4	CHECK SHIFT UP (D₃ TO D₄)		
Does A/T shift from D ₃ to D ₄ at the specified speed? <input type="checkbox"/> Read gear position, throttle position and vehicle speed. Specified speed when shifting from D ₃ to D ₄ : Refer to shift schedule, AT-370.			
Yes or No			
Yes	▶	GO TO 5.	
No	▶	Go to "11. A/T Does Not Shift: D ₃ → D ₄ ", AT-240. Continue ROAD TEST.	

SC
 EL
 IDX

TROUBLE DIAGNOSIS — BASIC INSPECTION

Road Test (Cont'd)

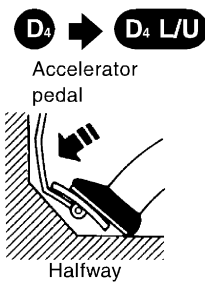
5	CHECK LOCK-UP (D₄ TO D₄L/U)		
Does A/T perform lock-up at the specified speed? <input type="checkbox"/> Read vehicle speed, throttle position when lock-up duty becomes 94%. Specified speed when lock-up occurs: Refer to Shift schedule, AT-370.			
			
Yes or No			
Yes	▶	GO TO 6.	
No	▶	Go to "12. A/T Does Not Perform Lock-up", AT-243. Continue ROAD TEST.	

SAT957I

6	CHECK HOLD LOCK-UP		
Does A/T hold lock-up condition for more than 30 seconds?			
Yes or No			
Yes	▶	GO TO 7.	
No	▶	Go to "13. A/T Does Not Hold Lock-up Condition", AT-245.	

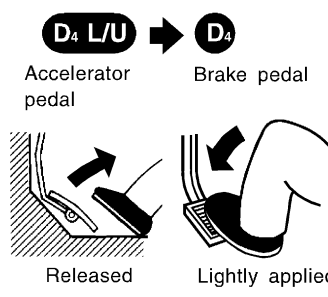
7	CHECK SHIFT DOWN (D₄L/U TO D₄)		
1. Release accelerator pedal.			
			
2. Is lock-up released when accelerator pedal is released?			
Yes or No			
Yes	▶	GO TO 8.	
No	▶	Go to "14. Lock-up Is Not Released", AT-247. Continue ROAD TEST.	

SAT958I

TROUBLE DIAGNOSIS — BASIC INSPECTION

Road Test (Cont'd)

8	CHECK SHIFT DOWN (D₄ TO D₃)	
<p>1. Decelerate vehicle by applying foot brake lightly.</p> <div style="text-align: center;"> <p style="font-size: small;">Accelerator pedal Brake pedal</p> <p style="font-size: small;">Released Lightly applied</p> </div>		
<p>2. Does engine speed return to idle smoothly when A/T is shifted from D₄ to D₃?</p> <p style="text-align: center;">Ⓛ Read gear position and engine speed.</p> <p style="text-align: center;">Yes or No</p>		
Yes	▶	<p>1. Stop vehicle.</p> <p>2. Go to "Cruise Test — Part 2", AT-78.</p>
No	▶	<p>Go to "15. Engine Speed Does Not Return To Idle (Light Braking D₄ → D₃)", AT-248.</p> <p>Continue ROAD TEST.</p>

GI

MA

EM

LC

SAT959I

EC

FE

AT

AX

SU

BR

ST

RS

BT

HA

SC

EL

IDX

TROUBLE DIAGNOSIS — BASIC INSPECTION

Road Test (Cont'd)

Cruise Test — Part 2

=NDAT0031S0405

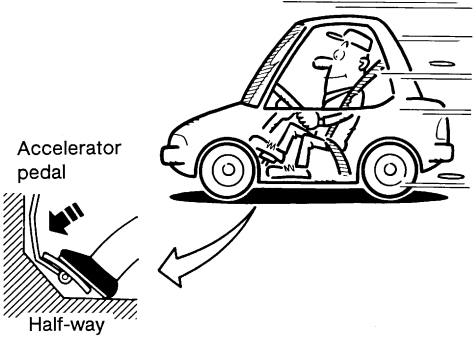
1	CHECK STARTING GEAR (D₁) POSITION	<p>1. Confirm overdrive control switch is in ON position. 2. Confirm selector lever is in D position. 3. Accelerate vehicle by half throttle again.</p> <div style="text-align: center;">  </div> <p>4. Does vehicle start from D₁? <input type="checkbox"/> Read gear position.</p> <p style="text-align: center;">Yes or No</p>	SAT495G
Yes	▶	GO TO 2.	
No	▶	Go to "16. Vehicle Does Not Start From D ₁ ", AT-250. Continue ROAD TEST.	

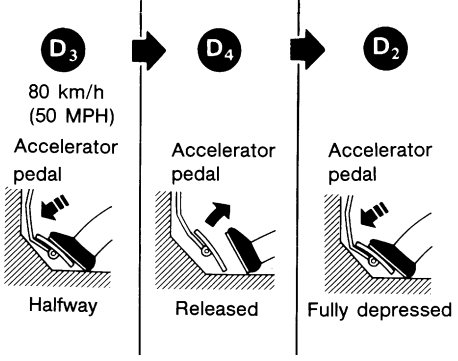
2	CHECK SHIFT UP AND SHIFT DOWN (D₃ TO D₄ TO D₂)	<p>1. Accelerate vehicle to 80 km/h (50 MPH) as shown in illustration. 2. Release accelerator pedal and then quickly depress it fully.</p> <div style="text-align: center;">  </div> <p>3. Does A/T shift from D₄ to D₂ as soon as accelerator pedal is depressed fully? <input type="checkbox"/> Read gear position and throttle position.</p> <p style="text-align: center;">Yes or No</p>	SAT404H
Yes	▶	GO TO 3.	
No	▶	Go to "9. A/T Does Not Shift: D ₁ → D ₂ Or Does Not Kickdown: D ₄ → D ₂ ", AT-234. Continue ROAD TEST.	

TROUBLE DIAGNOSIS — BASIC INSPECTION

Road Test (Cont'd)

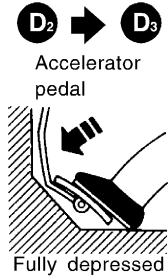
3	CHECK SHIFT UP (D₂ TO D₃)	<p>Does A/T shift from D₂ to D₃ at the specified speed?</p> <p>Ⓢ Read gear position, throttle position and vehicle speed. Specified speed when shifting from D₂ to D₃: Refer to "Shift Schedule", AT-370.</p> <div style="text-align: center;">  <p>D₂ → D₃ Accelerator pedal Fully depressed</p> </div> <p style="text-align: right;">SAT960I</p>	
Yes or No			
Yes	▶	GO TO 4.	
No	▶	Go to "10. A/T Does Not Shift: D ₂ → D ₃ ", AT-237. Continue ROAD TEST.	

GI
MA
EM
LC
EC
FE

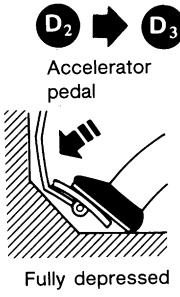
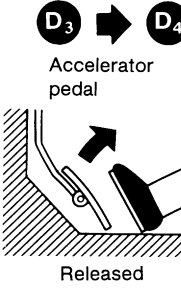
4	CHECK SHIFT UP (D₃ TO D₄) AND ENGINE BRAKE	<p>Release accelerator pedal after shifting from D₂ to D₃. Does A/T shift from D₃ to D₄ and does vehicle decelerate by engine brake?</p> <p>Ⓢ Read gear position, throttle position and vehicle speed.</p> <div style="display: flex; justify-content: space-around; align-items: center;"> <div style="text-align: center;">  <p>D₂ → D₃ Accelerator pedal Fully depressed</p> </div> <div style="text-align: center;">  <p>D₃ → D₄ Accelerator pedal Released</p> </div> </div> <p style="text-align: right;">SAT405H</p>	
Yes or No			
Yes	▶	1. Stop vehicle. 2. Go to "CRUISE TEST — Part 3", AT-80.	
No	▶	Go to "11. A/T Does Not Shift: D ₃ → D ₄ ", AT-240. Continue ROAD TEST.	

AT
AX
SU
BR
ST
RS
BT
HA
SC
EL
IDX

TROUBLE DIAGNOSIS — BASIC INSPECTION

Road Test (Cont'd)

Cruise Test — Part 3

=NDAT0031S0406

1 VEHICLE SPEED (D₄) POSITION

1. Confirm overdrive control switch is in ON position.
2. Confirm selector lever is in D position.
3. Accelerate vehicle using half-throttle to D₄.

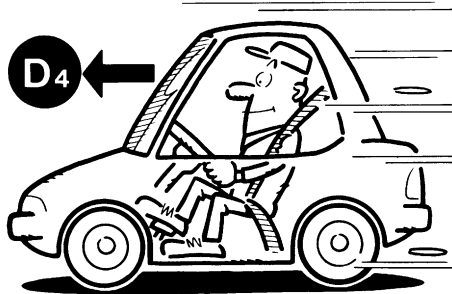

4. Release accelerator pedal.

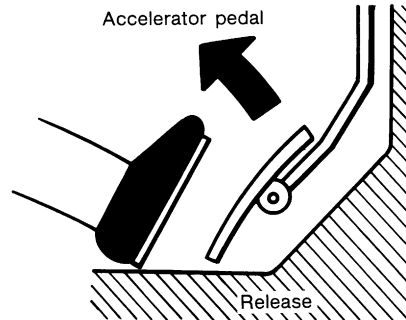

SAT812A

5. Set overdrive control switch to OFF position while driving in D₄.
6. Does A/T shift from D₄ to D₃ (O/D OFF)?

 **Read gear position and vehicle speed.**

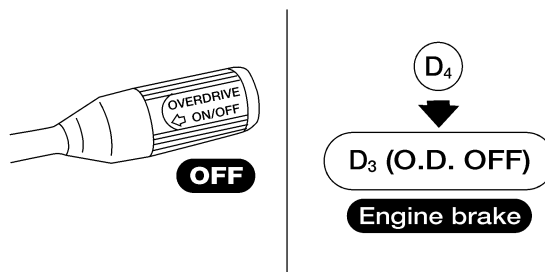

SAT813A

AAT571A

Yes or No

Yes	▶	GO TO 2.
No	▶	Go to "17. A/T Does Not Shift: D ₄ → D ₃ , When Overdrive Control Switch ON → OFF, AT-251. Continue ROAD TEST.

TROUBLE DIAGNOSIS — BASIC INSPECTION

Road Test (Cont'd)

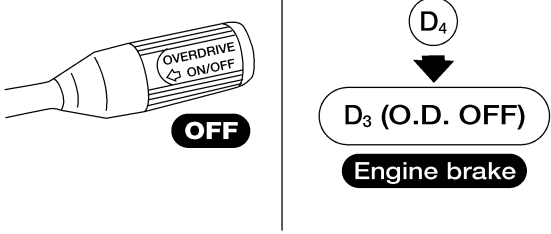
2	CHECK ENGINE BRAKE	Does vehicle decelerate by engine brake?	
		AAT571A	
Yes or No			
Yes	▶	GO TO 3.	
No	▶	Go to "15. Engine Speed Does Not Return To Idle (Light Braking D ₄ → D ₃)", AT-248. Continue ROAD TEST.	

GI
MA
EM
LC
EC
FE

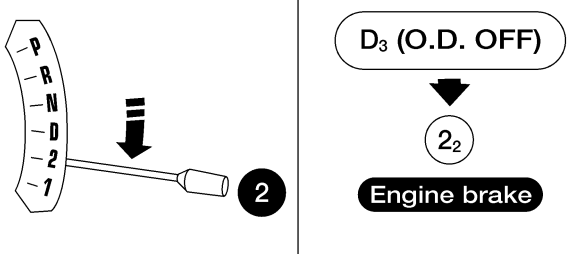
3	CHECK SHIFT DOWN (D₃ TO D₂)	1. Move selector lever from D to 2 position while driving in D ₃ (O/D OFF). 2. Does A/T shift from D ₃ (O/D OFF) to 2 ₂ ? <input type="checkbox"/> Read gear position.	
		AAT572A	
Yes or No			
Yes	▶	GO TO 4.	
No	▶	Go to "18. A/T Does Not Shift: D ₃ → D ₂ , When Selector Lever D → 2 Position", AT-252. Continue ROAD TEST.	

AT
AX
SU
BR
ST
RS
BT
HA

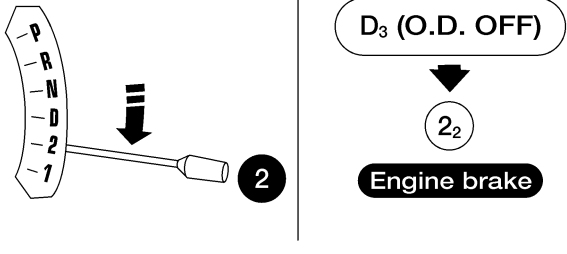
4	CHECK ENGINE BRAKE	Does vehicle decelerate by engine brake?	
		AAT572A	
Yes or No			
Yes	▶	GO TO 5.	
No	▶	Go to "15. Engine Speed Does Not Return To Idle (Light Braking D ₄ → D ₃)", AT-248. Continue ROAD TEST.	

SC
EL
IDX

TROUBLE DIAGNOSIS — BASIC INSPECTION

Road Test (Cont'd)

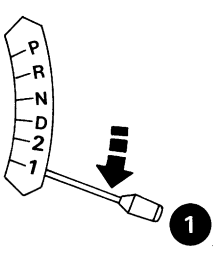
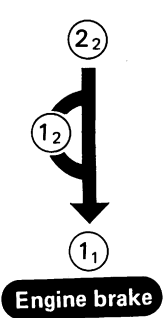
5	CHECK SHIFT DOWN (2₂ TO 1₁)	<p>1. Move selector lever from 2 to 1 position while driving in 2₂.</p> <p>2. Does A/T shift from 2₂ to 1₁ position?</p> <p> Read gear position.</p>	
			
Yes or No			
Yes	▶	GO TO 6.	
No	▶	Go to "19. A/T Does Not Shift: 2 ₂ → 1 ₁ , When Selector Lever 2 → 1 Position", AT-253. Continue ROAD TEST.	

SAT425F

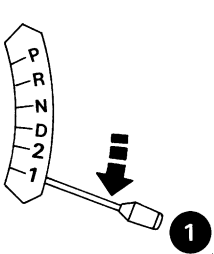
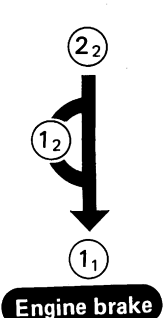
6	CHECK ENGINE BRAKE	<p>Does vehicle decelerate by engine brake?</p>	
			
Yes or No			
Yes	▶	<p>1. Stop vehicle.</p> <p>2. Perform self-diagnosis. Refer to TCM Self-diagnostic Procedure (No Tools), AT-48.</p>	
No	▶	Go to "20. Vehicle Does Not Decelerate By Engine Brake", AT-254. Continue ROAD TEST.	

SAT425F

TROUBLE DIAGNOSIS — GENERAL DESCRIPTION

Symptom Chart

Symptom Chart

NDAT0032

Numbers are arranged in order of inspection.

Perform inspections starting with number one and work up.

Items	Symptom	Condition	Diagnostic Item	Reference Page
NOT USED	Engine cannot be started in P and N positions. AT-218	ON vehicle	1. Ignition switch and starter	SC-10
			2. Control cable adjustment	AT-272
			3. Park/neutral position (PNP) switch adjustment	AT-271
	Engine starts in positions other than P and N. AT-218	ON vehicle	1. Control cable adjustment	AT-272
			2. Park/neutral position (PNP) switch adjustment	AT-271
	Transaxle noise in P and N positions.	ON vehicle	1. Fluid level	AT-61
			2. Line pressure test	AT-65
			3. Throttle position sensor (Adjustment)	EC-38
			4. Vehicle speed sensor-A/T (Revolution sensor) and vehicle speed sensor-MTR	AT-117, 205
			5. Engine speed signal	AT-123
		OFF vehicle	6. Oil pump	AT-298
			7. Torque converter	AT-281
	Vehicle moves when changing into P position or parking gear does not disengage when shifted out of P position. AT-219	ON vehicle	1. Control cable adjustment	AT-272
		OFF vehicle	2. Parking components	AT-350
	Vehicle runs in N position. AT-220	ON vehicle	1. Control cable adjustment	AT-272
OFF vehicle		2. Forward clutch	AT-324	
		3. Reverse clutch	AT-316	
		4. Overrun clutch	AT-324	
Slips/Will Not Engage	ON vehicle	1. Control cable adjustment	AT-272	
		2. Line pressure test	AT-65	
		3. Line pressure solenoid valve	AT-167	
		4. Control valve assembly	AT-270	
	OFF vehicle	5. Reverse clutch	AT-316	
		6. High clutch	AT-319	
		7. Forward clutch	AT-324	
		8. Overrun clutch	AT-324	
		9. Low & reverse brake	AT-329	

GI
 MA
 EM
 LC
 EC
 FE
AT
 AX
 SU
 BR
 ST
 RS
 BT
 HA
 SC
 EL
 IDX

TROUBLE DIAGNOSIS — GENERAL DESCRIPTION

Symptom Chart (Cont'd)

Items	Symptom	Condition	Diagnostic Item	Reference Page
NOT USED	Vehicle braked when shifting into R position.	ON vehicle	1. Fluid level	AT-61
			2. Control cable adjustment	AT-272
			3. Line pressure test	AT-65
			4. Line pressure solenoid valve	AT-167
			5. Control valve assembly	AT-270
		OFF vehicle	6. High clutch	AT-319
			7. Brake band	AT-341
			8. Forward clutch	AT-324
			9. Overrun clutch	AT-324
Shift Shock	Sharp shock in shifting from N to D position.	ON vehicle	1. Engine idling rpm	EC-38
			2. Throttle position sensor (Adjustment)	EC-38
			3. Line pressure test	AT-65
			4. A/T fluid temperature sensor	AT-110
			5. Engine speed signal	AT-123
			6. Line pressure solenoid valve	AT-167
			7. Control valve assembly	AT-270
			8. Accumulator N-D	AT-270
		OFF vehicle	9. Forward clutch	AT-324
Slips/Will Not Engage	Vehicle will not run in D and 2 positions (but runs in 1 and R positions).	ON vehicle	1. Control cable adjustment	AT-272
	Vehicle will not run in D, 1, 2 positions (but runs in R position). Clutch slips. Very poor acceleration. AT-228	OFF vehicle	2. Low one-way clutch	AT-276
		ON vehicle	1. Fluid level	AT-61
			2. Line pressure test	AT-65
			3. Line pressure solenoid valve	AT-167
			4. Control valve assembly	AT-270
			5. Accumulator N-D	AT-270
		OFF vehicle	6. Reverse clutch	AT-316
			7. High clutch	AT-319
			8. Forward clutch	AT-324
9. Forward one-way clutch	AT-332			
10. Low one-way clutch	AT-276			

TROUBLE DIAGNOSIS — GENERAL DESCRIPTION

Symptom Chart (Cont'd)

Items	Symptom	Condition	Diagnostic Item	Reference Page	
Slips/Will Not Engage	Clutches or brakes slip somewhat in starting.	ON vehicle	1. Fluid level	AT-61	GI
			2. Control cable adjustment	AT-272	
			3. Throttle position sensor (Adjustment)	EC-38	MA
			4. Line pressure test	AT-65	EM
			5. Line pressure solenoid valve	AT-167	
			6. Control valve assembly	AT-270	LC
			7. Accumulator N-D	AT-270	
		OFF vehicle	8. Forward clutch	AT-324	EC
			9. Reverse clutch	AT-316	
			10. Low & reverse brake	AT-329	FE
			11. Oil pump	AT-298	
			12. Torque converter	AT-281	AT
NOT USED	Excessive creep.	ON vehicle	1. Engine idling rpm	EC-38	
Slips/Will Not Engage	No creep at all. AT-224, 228	ON vehicle	1. Fluid level	AT-61	AX
			2. Line pressure test	AT-65	
			3. Control valve assembly	AT-270	SU
		OFF vehicle	4. Forward clutch	AT-324	BR
			5. Oil pump	AT-298	
			6. Torque converter	AT-281	ST

GI

MA

EM

LC

EC

FE

AT

AX

SU

BR

ST

RS

BT

HA

SC

EL

IDX

TROUBLE DIAGNOSIS — GENERAL DESCRIPTION

Symptom Chart (Cont'd)

Items	Symptom	Condition	Diagnostic Item	Reference Page
No Up Shift	Failure to change gear from D ₁ to D ₂ .	ON vehicle	1. Park/neutral position (PNP) switch adjustment	AT-271
			2. Control cable adjustment	AT-272
			3. Shift solenoid valve A	AT-173
			4. Control valve assembly	AT-270
			5. Vehicle speed sensor-A/T (Revolution sensor) and vehicle speed sensor-MTR	AT-117, 205
		OFF vehicle	6. Brake band	AT-341
	Failure to change gear from D ₂ to D ₃ .	ON vehicle	1. Park/neutral position (PNP) switch adjustment	AT-271
			2. Control cable adjustment	AT-272
			3. Shift solenoid valve B	AT-179
			4. Control valve assembly	AT-270
			5. Vehicle speed sensor-A/T (Revolution sensor) and vehicle speed sensor-MTR	AT-117, 205
		OFF vehicle	6. High clutch	AT-319
			7. Brake band	AT-341
	Failure to change gear from D ₃ to D ₄ .	ON vehicle	1. Park/neutral position (PNP) switch adjustment	AT-271
			2. Control cable adjustment	AT-272
3. Shift solenoid valve A			AT-173	
4. Vehicle speed sensor-A/T (Revolution sensor) and vehicle speed sensor-MTR			AT-117, 205	
5. A/T fluid temperature sensor			AT-110	
OFF vehicle		6. Brake band	AT-341	
Improper Shift Timing	Too high a gear change point from D ₁ to D ₂ , from D ₂ to D ₃ , from D ₃ to D ₄ . AT-234, 237, 240	ON vehicle	1. Throttle position sensor (Adjustment)	EC-38
			2. Vehicle speed sensor-A/T (Revolution sensor) and vehicle speed sensor-MTR	AT-117, 205
			3. Shift solenoid valve A	AT-173
			4. Shift solenoid valve B	AT-179
	Gear change directly from D ₁ to D ₃ occurs.	ON vehicle	1. Fluid level	AT-61
			2. Accumulator servo release	AT-270
		OFF vehicle	3. Brake band	AT-341
NOT USED	ON vehicle	1. Engine idling rpm	EC-38	
		2. Torque converter clutch solenoid valve	AT-154	
		3. Control valve assembly	AT-270	
	OFF vehicle	4. Torque converter	AT-281	

TROUBLE DIAGNOSIS — GENERAL DESCRIPTION

Symptom Chart (Cont'd)

Items	Symptom	Condition	Diagnostic Item	Reference Page	
Shift Shock	Too sharp a shock in change from D ₁ to D ₂ .	ON vehicle	1. Throttle position sensor (Adjustment)	EC-38	GI
			2. Line pressure test	AT-65	MA
			3. Accumulator servo release	AT-270	EM
			4. Control valve assembly	AT-270	EM
			5. A/T fluid temperature sensor	AT-110	EM
		OFF vehicle	6. Brake band	AT-341	LC
	Too sharp a shock in change from D ₂ to D ₃ .	ON vehicle	1. Throttle position sensor (Adjustment)	EC-38	EC
			2. Line pressure test	AT-65	EC
			3. Control valve assembly	AT-270	FE
		OFF vehicle	4. High clutch	AT-319	FE
			5. Brake band	AT-341	AT
	Too sharp a shock in change from D ₃ to D ₄ .	ON vehicle	1. Throttle position sensor (Adjustment)	EC-38	AX
			2. Line pressure test	AT-65	AX
			3. Control valve assembly	AT-270	SU
		OFF vehicle	4. Brake band	AT-341	SU
5. Overrun clutch			AT-324	BR	
Slips/Will Not Engage	Almost no shock or clutches slipping in change from D ₁ to D ₂ .	ON vehicle	1. Fluid level	AT-61	BR
			2. Throttle position sensor (Adjustment)	EC-38	ST
			3. Line pressure test	AT-65	ST
			4. Accumulator servo release	AT-270	RS
			5. Control valve assembly	AT-270	BT
		OFF vehicle	6. Brake band	AT-341	BT
	Almost no shock or slipping in change from D ₂ to D ₃ .	ON vehicle	1. Fluid level	AT-61	HA
			2. Throttle position sensor (Adjustment)	EC-38	HA
			3. Line pressure test	AT-65	SC
			4. Control valve assembly	AT-270	SC
		OFF vehicle	5. High clutch	AT-319	EL
			6. Forward clutch	AT-324	EL
	Almost no shock or slipping in change from D ₃ to D ₄ .	ON vehicle	1. Fluid level	AT-61	IDX
			2. Throttle position sensor (Adjustment)	EC-38	IDX
			3. Line pressure test	AT-65	IDX
			4. Control valve assembly	AT-270	IDX
		OFF vehicle	5. High clutch	AT-319	IDX
			6. Brake band	AT-341	IDX

TROUBLE DIAGNOSIS — GENERAL DESCRIPTION

Symptom Chart (Cont'd)

Items	Symptom	Condition	Diagnostic Item	Reference Page
NOT USED	Vehicle braked by gear change from D ₁ to D ₂ .	ON vehicle	1. Fluid level	AT-61
		OFF vehicle	2. Reverse clutch	AT-316
			3. Low & reverse brake	AT-329
			4. High clutch	AT-319
			5. Low one-way clutch	AT-276
	Vehicle braked by gear change from D ₂ to D ₃ .	ON vehicle	1. Fluid level	AT-61
		OFF vehicle	2. Brake band	AT-341
	Vehicle braked by gear change from D ₃ to D ₄ .	ON vehicle	1. Fluid level	AT-61
		OFF vehicle	2. Overrun clutch	AT-324
			3. Forward one-way clutch	AT-332
			4. Reverse clutch	AT-316
Maximum speed not attained. Acceleration poor.	ON vehicle	1. Fluid level	AT-61	
		2. Park/neutral position (PNP) switch adjustment	AT-271	
		3. Shift solenoid valve A	AT-173	
		4. Shift solenoid valve B	AT-179	
		5. Control valve assembly	AT-270	
	OFF vehicle	6. Reverse clutch	AT-316	
		7. High clutch	AT-319	
		8. Brake band	AT-341	
		9. Low & reverse brake	AT-329	
		10. Oil pump	AT-298	
		11. Torque converter	AT-281	

TROUBLE DIAGNOSIS — GENERAL DESCRIPTION

Symptom Chart (Cont'd)

Items	Symptom	Condition	Diagnostic Item	Reference Page	
No Down Shift	Failure to change gear from D ₄ to D ₃ .	ON vehicle	1. Fluid level	AT-61	GI
			2. Throttle position sensor (Adjustment)	EC-38	MA
			3. Overrun clutch solenoid valve	AT-192	EM
			4. Shift solenoid valve A	AT-173	LC
			5. Line pressure solenoid valve	AT-167	EC
			6. Control valve assembly	AT-270	FE
		OFF vehicle	7. Low & reverse brake	AT-329	AT
			8. Overrun clutch	AT-324	AX
	Failure to change gear from D ₃ to D ₂ or from D ₄ to D ₂ .	ON vehicle	1. Fluid level	AT-61	SU
			2. Throttle position sensor (Adjustment)	EC-38	BR
			3. Shift solenoid valve A	AT-173	ST
			4. Shift solenoid valve B	AT-179	RS
			5. Control valve assembly	AT-270	BT
		OFF vehicle	6. High clutch	AT-319	HA
			7. Brake band	AT-341	SC
Failure to change gear from D ₂ to D ₁ or from D ₃ to D ₁ .	ON vehicle	1. Fluid level	AT-61	EL	
		2. Throttle position sensor (Adjustment)	EC-38	IDX	
		3. Shift solenoid valve A	AT-173		
		4. Shift solenoid valve B	AT-179		
		5. Control valve assembly	AT-270		
	OFF vehicle	6. Low one-way clutch	AT-276		
		7. High clutch	AT-319		
		8. Brake band	AT-341		
Shift Shock	Gear change shock felt during deceleration by releasing accelerator pedal.	ON vehicle	1. Throttle position sensor (Adjustment)	EC-38	HA
			2. Line pressure test	AT-65	SC
			3. Overrun clutch solenoid valve	AT-192	EL
			4. Control valve assembly	AT-270	EL

TROUBLE DIAGNOSIS — GENERAL DESCRIPTION

Symptom Chart (Cont'd)

Items	Symptom	Condition	Diagnostic Item	Reference Page	
Improper Shift Timing	Too high a change point from D ₄ to D ₃ , from D ₃ to D ₂ , from D ₂ to D ₁ .	ON vehicle	1. Throttle position sensor (Adjustment)	EC-38	
			2. Vehicle speed sensor-A/T (Revolution sensor) and vehicle speed sensor-MTR	AT-117, 205	
	Kickdown does not operate when depressing pedal in D ₄ within kickdown vehicle speed.	ON vehicle	1. Throttle position sensor (Adjustment)	EC-38	
			2. Vehicle speed sensor-A/T (Revolution sensor) and vehicle speed sensor-MTR	AT-117, 205	
			3. Shift solenoid valve A	AT-173	
			4. Shift solenoid valve B	AT-179	
	Kickdown operates or engine overruns when depressing pedal in D ₄ beyond kickdown vehicle speed limit.	ON vehicle	1. Vehicle speed sensor-A/T (Revolution sensor) and vehicle speed sensor-MTR	AT-117, 205	
			2. Throttle position sensor (Adjustment)	EC-38	
			3. Shift solenoid valve A	AT-173	
			4. Shift solenoid valve B	AT-179	
	Slips/Will Not Engage	Races extremely fast or slips in changing from D ₄ to D ₃ when depressing pedal.	ON vehicle	1. Fluid level	AT-61
				2. Throttle position sensor (Adjustment)	EC-38
3. Line pressure test				AT-65	
4. Line pressure solenoid valve				AT-167	
5. Control valve assembly				AT-270	
OFF vehicle			6. High clutch	AT-319	
			7. Forward clutch	AT-324	
Races extremely fast or slips in changing from D ₄ to D ₂ when depressing pedal.		ON vehicle	1. Fluid level	AT-61	
			2. Throttle position sensor (Adjustment)	EC-38	
			3. Line pressure test	AT-65	
			4. Line pressure solenoid valve	AT-167	
			5. Shift solenoid valve A	AT-173	
		OFF vehicle	6. Control valve assembly	AT-270	
			7. Brake band	AT-341	
			8. Forward clutch	AT-324	

TROUBLE DIAGNOSIS — GENERAL DESCRIPTION

Symptom Chart (Cont'd)

Items	Symptom	Condition	Diagnostic Item	Reference Page	
Slips/Will Not Engage	Races extremely fast or slips in changing from D ₃ to D ₂ when depressing pedal.	ON vehicle	1. Fluid level	AT-61	GI
			2. Throttle position sensor (Adjustment)	EC-38	MA
			3. Line pressure test	AT-65	EM
			4. Line pressure solenoid valve	AT-167	LC
			5. Control valve assembly	AT-270	EC
			6. A/T fluid temperature sensor	AT-110	FE
		OFF vehicle	7. Brake band	AT-341	AT
			8. Forward clutch	AT-324	AX
			9. High clutch	AT-319	SU
	Races extremely fast or slips in changing from D ₄ or D ₃ to D ₁ when depressing pedal.	ON vehicle	1. Fluid level	AT-61	BR
			2. Throttle position sensor (Adjustment)	EC-38	ST
			3. Line pressure test	AT-65	RS
			4. Line pressure solenoid valve	AT-167	BT
			5. Control valve assembly	AT-270	HA
		OFF vehicle	6. Forward clutch	AT-324	SC
7. Forward one-way clutch			AT-332	EL	
8. Low one-way clutch			AT-276	IDX	
Vehicle will not run in any position.	ON vehicle	1. Fluid level	AT-61		
		2. Control cable adjustment	AT-272		
		3. Line pressure test	AT-65		
		4. Line pressure solenoid valve	AT-167		
	OFF vehicle	5. Oil pump	AT-298		
		6. High clutch	AT-319		
		7. Brake band	AT-341		
		8. Low & reverse brake	AT-329		
		9. Torque converter	AT-281		
		10. Parking components	AT-350		
NOT USED	Transaxle noise in D, 2, 1 and R positions.	ON vehicle	1. Fluid level	AT-61	
		ON vehicle	2. Torque converter	AT-281	

TROUBLE DIAGNOSIS — GENERAL DESCRIPTION

Symptom Chart (Cont'd)

Items	Symptom	Condition	Diagnostic Item	Reference Page
No Down Shift	Failure to change from D ₃ to 2 ₂ when changing lever into 2 position. AT-248	ON vehicle	1. Park/neutral position (PNP) switch adjustment	AT-271
			2. Throttle position sensor (Adjustment)	EC-38
			3. Overrun clutch solenoid valve	AT-192
			4. Shift solenoid valve B	AT-179
			5. Shift solenoid valve A	AT-173
			6. Control valve assembly	AT-270
			7. Control cable adjustment	AT-272
		OFF vehicle	8. Brake band	AT-341
			9. Overrun clutch	AT-324
Improper Shift Timing	Gear change from 2 ₂ to 2 ₃ in 2 position.	ON vehicle	1. Park/neutral position (PNP) switch adjustment	AT-271
NOT USED	Engine brake does not operate in "1" position. AT-250	ON vehicle	1. Park/neutral position (PNP) switch adjustment	AT-271
			2. Control cable adjustment	AT-272
			3. Throttle position sensor (Adjustment)	EC-38
			4. Vehicle speed sensor-A/T (Revolution sensor) and vehicle speed sensor-MTR	AT-117, 205
			5. Shift solenoid valve A	AT-173
			6. Control valve assembly	AT-270
			7. Overrun clutch solenoid valve	AT-192
		OFF vehicle	8. Overrun clutch	AT-324
			9. Low & reverse brake	AT-329
Improper Shift Timing	Gear change from 1 ₁ to 1 ₂ in 1 position.	ON vehicle	1. Park/neutral position (PNP) switch adjustment	AT-271
			2. Control cable adjustment	AT-272
No Down Shift	Does not change from 1 ₂ to 1 ₁ in 1 position.	ON vehicle	1. Park/neutral position (PNP) switch adjustment	AT-271
			2. Vehicle speed sensor-A/T (Revolution sensor) and vehicle speed sensor-MTR	AT-117, 205
			3. Shift solenoid valve A	AT-173
			4. Control valve assembly	AT-270
			5. Overrun clutch solenoid valve	AT-192
		OFF vehicle	6. Overrun clutch	AT-324
			7. Low & reverse brake	AT-329
Shift Shock	Large shock changing from 1 ₂ to 1 ₁ in 1 position.	ON vehicle	1. Control valve assembly	AT-270
		OFF vehicle	2. Low & reverse brake	AT-329

TROUBLE DIAGNOSIS — GENERAL DESCRIPTION

Symptom Chart (Cont'd)

Items	Symptom	Condition	Diagnostic Item	Reference Page	
NOT USED	Transaxle overheats.	ON vehicle	1. Fluid level	AT-61	GI
			2. Engine idling rpm	EC-38	
			3. Throttle position sensor (Adjustment)	EC-38	MA
			4. Line pressure test	AT-65	EM
			5. Line pressure solenoid valve	AT-167	
			6. Control valve assembly	AT-270	LC
		OFF vehicle	7. Oil pump	AT-298	
			8. Reverse clutch	AT-316	EC
			9. High clutch	AT-319	
			10. Brake band	AT-341	FE
			11. Forward clutch	AT-324	
			12. Overrun clutch	AT-324	AT
			13. Low & reverse brake	AT-329	
			14. Torque converter	AT-281	AX
	ATF shoots out during operation. White smoke emitted from exhaust pipe during operation.	ON vehicle	1. Fluid level	AT-61	SU
		OFF vehicle	2. Reverse clutch	AT-316	
			3. High clutch	AT-319	BR
			4. Brake band	AT-341	
			5. Forward clutch	AT-324	ST
			6. Overrun clutch	AT-324	
			7. Low & reverse brake	AT-329	RS
Offensive smell at fluid charging pipe.	ON vehicle	1. Fluid level	AT-61		
	OFF vehicle	2. Torque converter	AT-281	BT	
		3. Oil pump	AT-298		
		4. Reverse clutch	AT-316	HA	
		5. High clutch	AT-319		
		6. Brake band	AT-341	SC	
		7. Forward clutch	AT-324		
		8. Overrun clutch	AT-324	EL	
		9. Low & reverse brake	AT-329	IDX	

TROUBLE DIAGNOSIS — GENERAL DESCRIPTION

Symptom Chart (Cont'd)

Items	Symptom	Condition	Diagnostic Item	Reference Page
No Lock-up Engagement/ TCC Inoperative	Torque converter is not locked up.	ON vehicle	1. Throttle position sensor (Adjustment)	EC-38
			2. Vehicle speed sensor-A/T (Revolution sensor) and vehicle speed sensor-MTR	AT-117, 205
			3. Park/neutral position (PNP) switch adjustment	AT-271
			4. Engine speed signal	AT-123
			5. A/T fluid temperature sensor	AT-110
			6. Line pressure test	AT-65
			7. Torque converter clutch sole- noid valve	AT-154
			8. Control valve assembly	AT-270
		OFF vehicle	9. Torque converter	AT-281
	Torque converter clutch pis- ton slip.	ON vehicle	1. Fluid level	AT-61
			2. Throttle position sensor (Adjustment)	EC-38
			3. Line pressure test	AT-65
			4. Torque converter clutch sole- noid valve	AT-154
			5. Line pressure solenoid valve	AT-167
			6. Control valve assembly	AT-270
	OFF vehicle	7. Torque converter	AT-281	
Lock-up point is extremely high or low. AT-243	ON vehicle	1. Throttle position sensor (Adjustment)	EC-38	
		2. Vehicle speed sensor-A/T (Revolution sensor) and vehicle speed sensor-MTR	AT-117, 205	
		3. Torque converter clutch sole- noid valve	AT-154	
		4. Control valve assembly	AT-270	

TROUBLE DIAGNOSIS — GENERAL DESCRIPTION

Symptom Chart (Cont'd)

Items	Symptom	Condition	Diagnostic Item	Reference Page	
No Up Shift	A/T does not shift to D ₄ when driving with overdrive control switch ON.	ON vehicle	1. Throttle position sensor (Adjustment)	EC-38	GI
			2. Park/neutral position (PNP) switch adjustment	AT-271	MA
			3. Vehicle speed sensor-A/T (Revolution sensor) and vehicle speed sensor-MTR	AT-117, 205	EM
			4. Shift solenoid valve A	AT-173	LC
			5. Overrun clutch solenoid valve	AT-192	
			6. Control valve assembly	AT-270	EC
			7. A/T fluid temperature sensor	AT-110	
			8. Line pressure solenoid valve	AT-167	FE
		OFF vehicle	9. Brake band	AT-341	
			10. Overrun clutch	AT-324	AT
NOT USED	Engine is stopped at R, D, 2 and 1 positions.	ON vehicle	1. Fluid level	AT-61	
			2. Torque converter clutch solenoid valve	AT-154	AX
			3. Shift solenoid valve B	AT-179	SU
			4. Shift solenoid valve A	AT-173	
			5. Control valve assembly	AT-270	BR

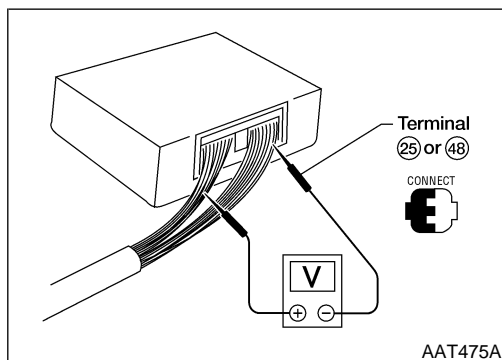

TCM Terminals and Reference Value PREPARATION

NDAT0033

- Measure voltage between each terminal and terminal 25 or 48 by following "TCM INSPECTION TABLE".

NDAT0033S01

BT

HA

SC

EL

IDX

TROUBLE DIAGNOSIS — GENERAL DESCRIPTION

TCM Terminals and Reference Value (Cont'd)

TCM HARNESS CONNECTOR TERMINAL LAYOUT



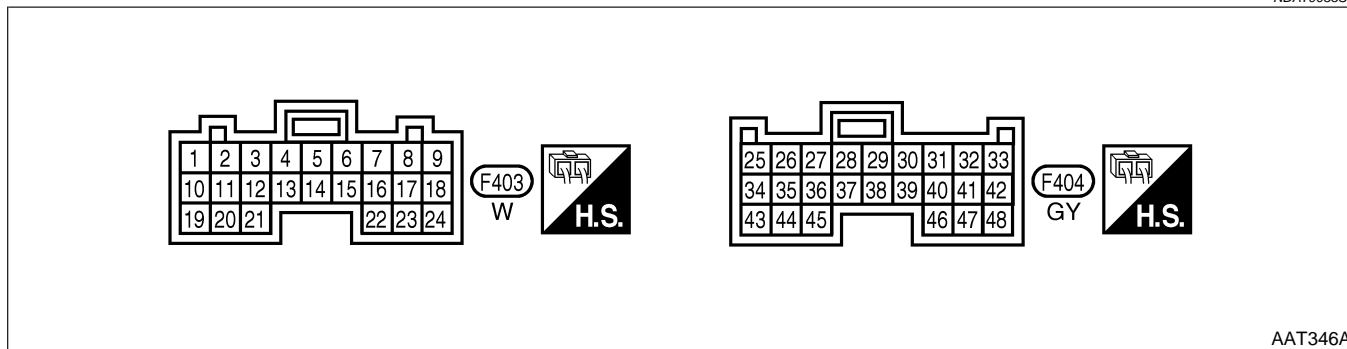

NDAT0033S02



TCM INSPECTION TABLE



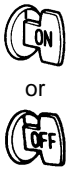





(Data are reference values.)

NDAT0033S03

Terminal No.	Wire color	Item	Condition		Judgement standard (Approx.)
1	G/R	Line pressure solenoid valve		When releasing accelerator pedal after warming up engine.	1.5 - 2.5V
				When depressing accelerator pedal fully after warming up engine.	0V
2	Y/B	Line pressure solenoid valve (with dropping resistor)		When releasing accelerator pedal after warming up engine.	4 - 14V
				When depressing accelerator pedal fully after warming up engine.	0V
3	OR/L	Torque converter clutch solenoid valve		When A/T performs lock-up.	8 - 15V
				When A/T does not perform lock-up.	0V
5*	G/W	DT1		—	—
6*	W	DT2		—	—
7*	P/B	DT3		—	—
10	LG	Power source		When turning ignition switch to ON.	Battery voltage
				When turning ignition switch to OFF.	0V
11	Y/PU	Shift solenoid valve A		When shift solenoid valve A operates. (When driving in D ₁ or D ₄ .)	Battery voltage
				When shift solenoid valve A does not operate. (When driving in D ₂ or D ₃ .)	0V
12	Y/G	Shift solenoid valve B		When shift solenoid valve B operates. (When driving in D ₁ or D ₂ .)	Battery voltage
				When shift solenoid valve B does not operate. (When driving in D ₃ or D ₄ .)	0V











TROUBLE DIAGNOSIS — GENERAL DESCRIPTION

TCM Terminals and Reference Value (Cont'd)

Terminal No.	Wire color	Item	Condition		Judgement standard (Approx.)	
13	L/OR	O/D OFF indicator lamp		When setting overdrive control switch in OFF position.	0V	GI
				When setting overdrive control switch in ON position.	Battery voltage	MA
14*	GY/R	N position signal		When setting selector lever to P or N position.	Battery voltage	EM
				When setting selector lever to other positions.	0V	LC
15*	G/B	OBD-II output		—	—	EC
16	BR/Y	Closed throttle position switch (in throttle position switch)		When releasing accelerator pedal after warming up engine.	Battery voltage	AT
				When depressing accelerator pedal after warming up engine.	0V	AX
17	R/W	Wide open throttle position switch (in throttle position switch)		When depressing accelerator pedal more than half-way after warming up engine.	Battery voltage	SU
				When releasing accelerator pedal after warming up engine.	0V	BR
18	R/Y	ASCD cruise switch		When ASCD cruise is being performed. ("CRUISE" lamp comes on.)	Battery voltage	ST
				When ASCD cruise is not being performed. ("CRUISE" lamp does not come on.)	0V	RS
19	LG	Power source		Same as No. 10		BT
20	OR/B	Overrun clutch solenoid valve		When overrun clutch solenoid valve operates.	Battery voltage	HA
				When overrun clutch solenoid valve does not operate.	0V	SC
22	G/OR	Overdrive control switch		When setting overdrive control switch in ON position	Battery voltage	EL
				When setting overdrive control switch in OFF position	0V	IDX
24	LG/R	ASCD OD cut signal		When "ACCEL" set switch on ASCD cruise is in D ₄ position.	5 - 10V	
				When "ACCEL" set switch on ASCD cruise is in D ₃ position.	2V or less	
25	B/R	Ground		—	—	



TROUBLE DIAGNOSIS — GENERAL DESCRIPTION

TCM Terminals and Reference Value (Cont'd)

Terminal No.	Wire color	Item	Condition		Judgement standard (Approx.)
26	L/B	PNP switch 1 position		When setting selector lever to 1 position.	Battery voltage
				When setting selector lever to other positions.	0V
27	L/Y	PNP switch 2 position		When setting selector lever to 2 position.	Battery voltage
				When setting selector lever to other positions.	0V
28	PU	Power source (Memory back-up)	 or 	When turning ignition switch to OFF.	Battery voltage
				When turning ignition switch to ON.	Battery voltage
29	W	Revolution sensor (Measure in AC range)		When vehicle cruises at 30 km/h (19 MPH).	1V or more Voltage rises gradually in response to vehicle speed.
				When vehicle parks.	0V
30**	Y/R	RX		—	—
31**	Y/B	TX		—	—
32	BR	Throttle position sensor (Power source)		Ignition switch "ON"	4.5 - 5.5V
			Ignition switch "OFF"	0V	
34	L/W	PNP switch D position		When setting selector lever to D position.	Battery voltage
				When setting selector lever to other positions.	0V
35	L/R	PNP switch R position		When setting selector lever to R position.	Battery voltage
				When setting selector lever to other positions.	0V
36	L	PNP switch P or N position		When setting selector lever to P or N position.	Battery voltage
				When setting selector lever to other positions.	0V
39	G/W	Engine speed signal		When engine runs at idle speed.	0.6V
				When engine runs at 4,000 rpm.	1.6V
40	G/Y	Vehicle speed sensor		When moving vehicle at 2 to 3 km/h (1 to 2 MPH) for 1 m (3 ft) or more.	Voltage varies between less than 1V and more than 4.5V

TROUBLE DIAGNOSIS — GENERAL DESCRIPTION

TCM Terminals and Reference Value (Cont'd)

Terminal No.	Wire color	Item	Condition		Judgement standard (Approx.)
41	R/G	Throttle position sensor		When depressing accelerator pedal slowly after warming up engine. (Voltage rises gradually in response to throttle position.)	Fully-closed throttle: 0.5V Fully-open throttle: 4V
42	B/Y	Throttle position sensor (Ground)		—	—
47	SB	A/T fluid temperature sensor		When ATF temperature is 20°C (68°F).	1.5V
				When ATF temperature is 80°C (176°F).	0.5V
48	B/R	Ground		—	—

*: These terminals are connected to the ECM.

** : These terminals are connected to the data link connector for CONSULT-II.

GI

MA

EM

LC

EC

FE

AT

AX

SU

BR

ST

RS

BT

HA

SC

EL

IDX

TROUBLE DIAGNOSIS FOR POWER SUPPLY

Wiring Diagram — AT — MAIN

Wiring Diagram — AT — MAIN

NDAT0034

AT-MAIN-01

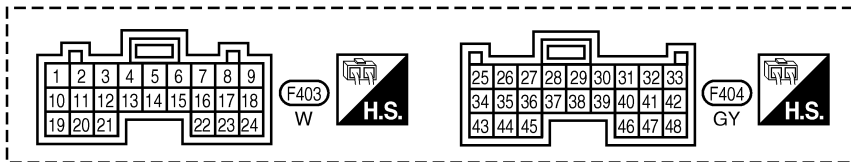
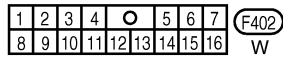
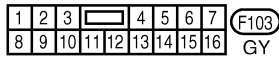
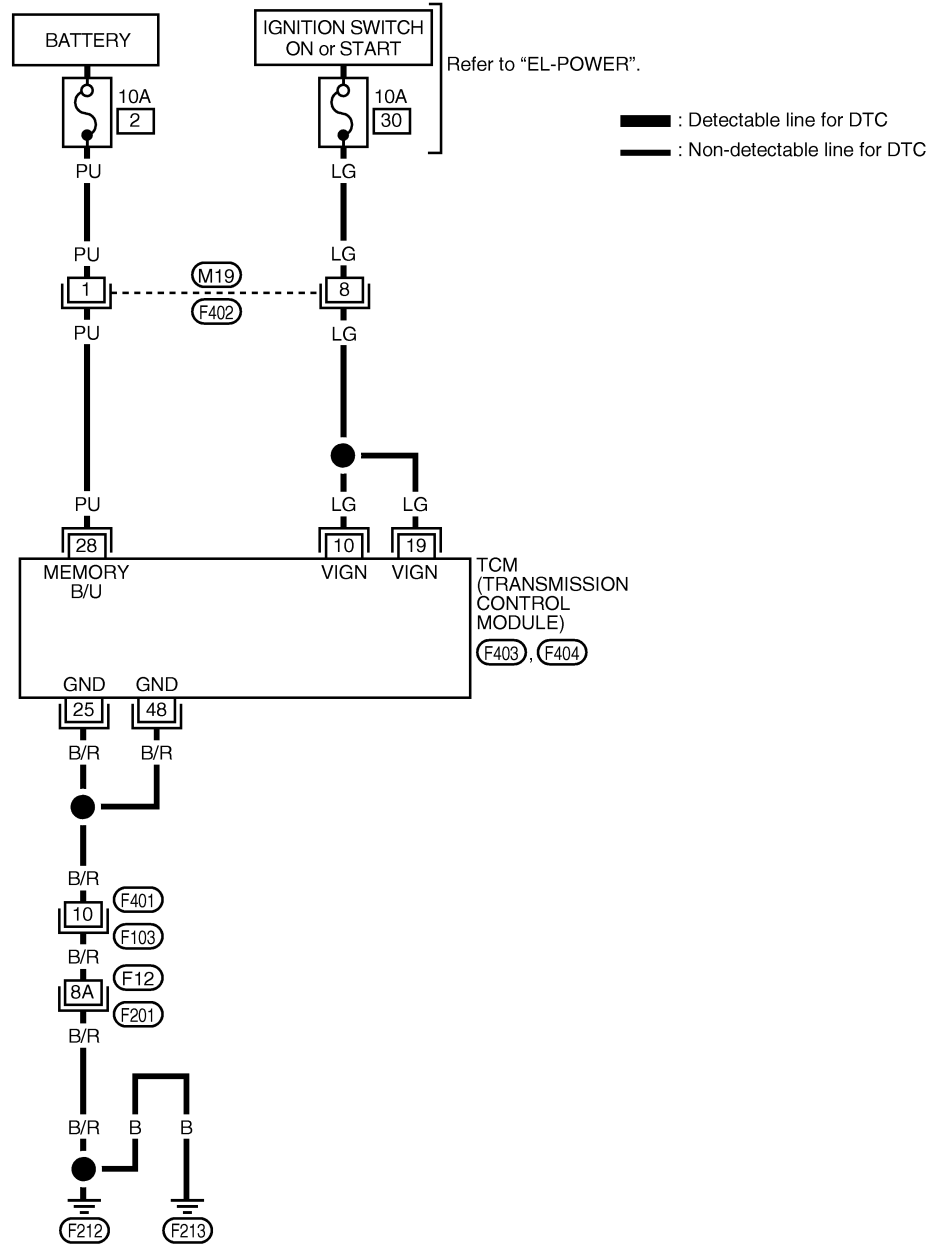

Refer to the following.
 (F12), (F201) SUPER MULTIPLE
 JUNCTION (SMJ)





WAT054

TROUBLE DIAGNOSIS FOR POWER SUPPLY

Wiring Diagram — AT — MAIN (Cont'd)

TCM TERMINALS AND REFERENCE VALUE

NDAT0034S01

Terminal No.	Wire color	Item	Condition	Judgement standard (Approx.)
10	LG	Power source		Battery voltage
			or 	0V
19	LG	Power source		Same as No. 10
25	B/R	Ground	—	—
28	PU	Power source (Memory back-up)		Battery voltage
			or 	Battery voltage
48	B/R	Ground	—	—

GI
MA
EM
LC
EC
FE
AT

DIAGNOSTIC PROCEDURE

NDAT0034S02

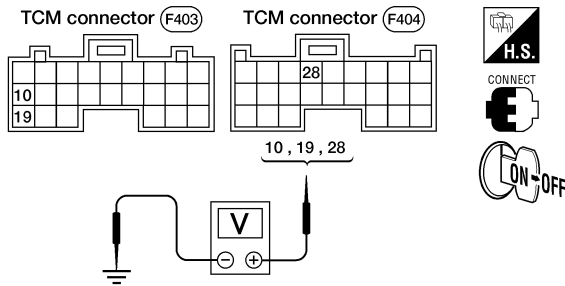
1	CHECK TCM POWER SOURCE—STEP 1.
<p>1. Turn ignition switch to ON position. (Do not start engine.)</p> <p>2. Check voltage between TCM terminals 10, 19, 28 and ground.</p> <div style="text-align: center;">  </div> <p>Voltage: Battery voltage</p> <p style="text-align: right;">AAT347A</p>	
OK or NG	
OK	▶ GO TO 2.
NG	▶ Check the following items: <ul style="list-style-type: none"> • Harness for short or open between ignition switch and TCM terminals 10, 19 and 28 (Main harness) • Ignition switch and fuse Refer to EL-10 , "POWER SUPPLY ROUTING".

AX
SU
BR
ST
RS
BT
HA
SC
EL
IDX

TROUBLE DIAGNOSIS FOR POWER SUPPLY

Wiring Diagram — AT — MAIN (Cont'd)

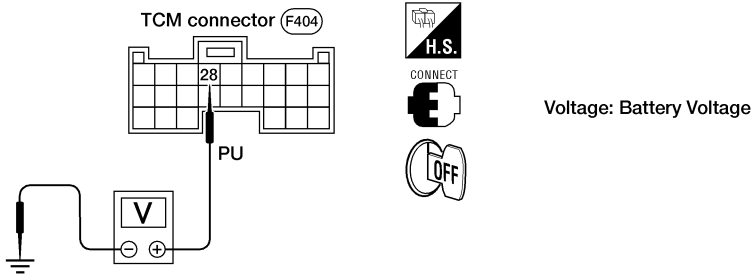
2	CHECK TCM POWER SOURCE—STEP 2.	<p>1. Turn ignition switch to OFF position. 2. Check voltage between TCM terminal 28 and ground.</p> <div style="text-align: center;">  </div> <p style="text-align: right;">WAT067</p>
		If OK, check harness for short to ground and short to power.
		OK or NG
OK	▶	GO TO 3.
NG	▶	<p>Check the following items:</p> <ul style="list-style-type: none"> ● Harness for short or open between ignition switch and TCM terminal 28 (Main harness) ● Ignition switch and fuse <p>Refer to EL-10, "POWER SUPPLY ROUTING".</p>

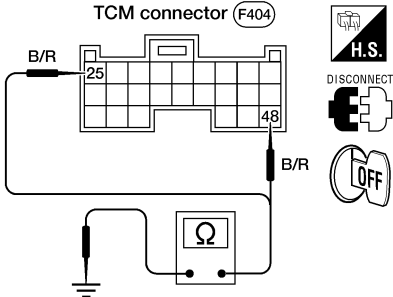
3	CHECK TCM GROUND CIRCUIT.	<p>1. Turn ignition switch to OFF position. 2. Disconnect TCM harness connector. 3. Check continuity between TCM terminals 25, 48 and ground.</p> <div style="text-align: center;">  </div> <p style="text-align: right;">AAT348A</p>
		Continuity should exist.
		If OK, check harness for short to ground and short to power.
		OK or NG
OK	▶	INSPECTION END
NG	▶	Repair open circuit or short to ground or short to power in harness or connectors.

DTC P0705 PARK/NEUTRAL POSITION SWITCH

Description

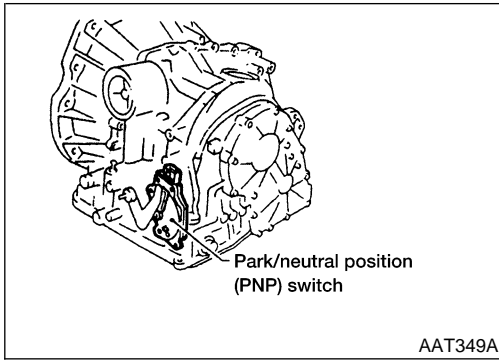

Description

- The park/neutral position (PNP) switch includes a transmission range switch. NDAT0035
- The transmission range switch detects the selector lever position and sends a signal to the TCM.

GI
MA
EM
LC

TCM TERMINALS AND REFERENCE VALUE

NDAT0035S01

Remarks: Specification data are reference values.

Terminal No.	Wire color	Item	Condition	Judgement standard (Approx.)
26	L/B	PNP switch 1 position	When setting selector lever to 1 position.	Battery voltage
			When setting selector lever to other positions.	0V
27	L/Y	PNP switch 2 position	When setting selector lever to 2 position.	Battery voltage
			When setting selector lever to other positions.	0V
34	L/W	PNP switch D position	When setting selector lever to D position.	Battery voltage
			When setting selector lever to other positions.	0V
35	L/R	PNP switch R position	When setting selector lever to R position.	Battery voltage
			When setting selector lever to other positions.	0V
36	L	PNP switch P or N position	When setting selector lever to P or N position.	Battery voltage
			When setting selector lever to other positions.	0V

EC
FE

AT

AX

SU

BR

ST

RS

BT

HA

ON BOARD DIAGNOSIS LOGIC

NDAT0035S02

Diagnostic trouble code	Malfunction is detected when ...	Check items (Possible cause)
(P) : PNP SW/CIRC (P0705) : P0705 (MIL) : MIL Code No. 1101	TCM does not receive the correct voltage signal from the switch based on the gear position.	<ul style="list-style-type: none"> • Harness or connectors (The park/neutral position (PNP) switch circuit is open or shorted.) • Park/neutral position (PNP) switch

SC

EL

IDX

DTC P0705 PARK/NEUTRAL POSITION SWITCH

Description (Cont'd)

SELECT SYSTEM
A/T
ENGINE

SAT014K

SELECT DIAG MODE
WORK SUPPORT
SELF-DIAG RESULTS
DATA MONITOR
DATA MONITOR (SPEC)
ACTIVE TEST
DTC & SRT CONFIRMATION

SEF949Y

DIAGNOSTIC TROUBLE CODE (DTC) CONFIRMATION PROCEDURE

=NDAT0035S03

CAUTION:

Always drive vehicle at a safe speed.

NOTE:

If "DIAGNOSTIC TROUBLE CODE CONFIRMATION PROCEDURE" has been previously conducted, always turn ignition switch OFF and wait at least 5 seconds before conducting the next test.

After the repair, perform the following procedure to confirm the malfunction is eliminated.

With CONSULT-II

- 1) Turn ignition switch ON.
- 2) Select "DATA MONITOR" mode for "ENGINE" with CONSULT-II.
- 3) Start engine and maintain the following conditions for at least 5 consecutive seconds.

VHCL SPEED SE: 10 km/h (6 MPH) or more

THRTL POS SEN: More than 1.3V

Selector lever: D position (O/D ON or OFF)

With GST

Follow the procedure "With CONSULT-II".

DTC P0705 PARK/NEUTRAL POSITION SWITCH

Wiring Diagram — AT — PNP/SW

Wiring Diagram — AT — PNP/SW

NDAT0197

AT-PNP/SW-01

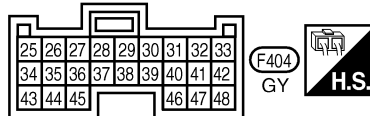
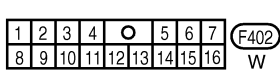
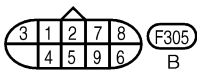
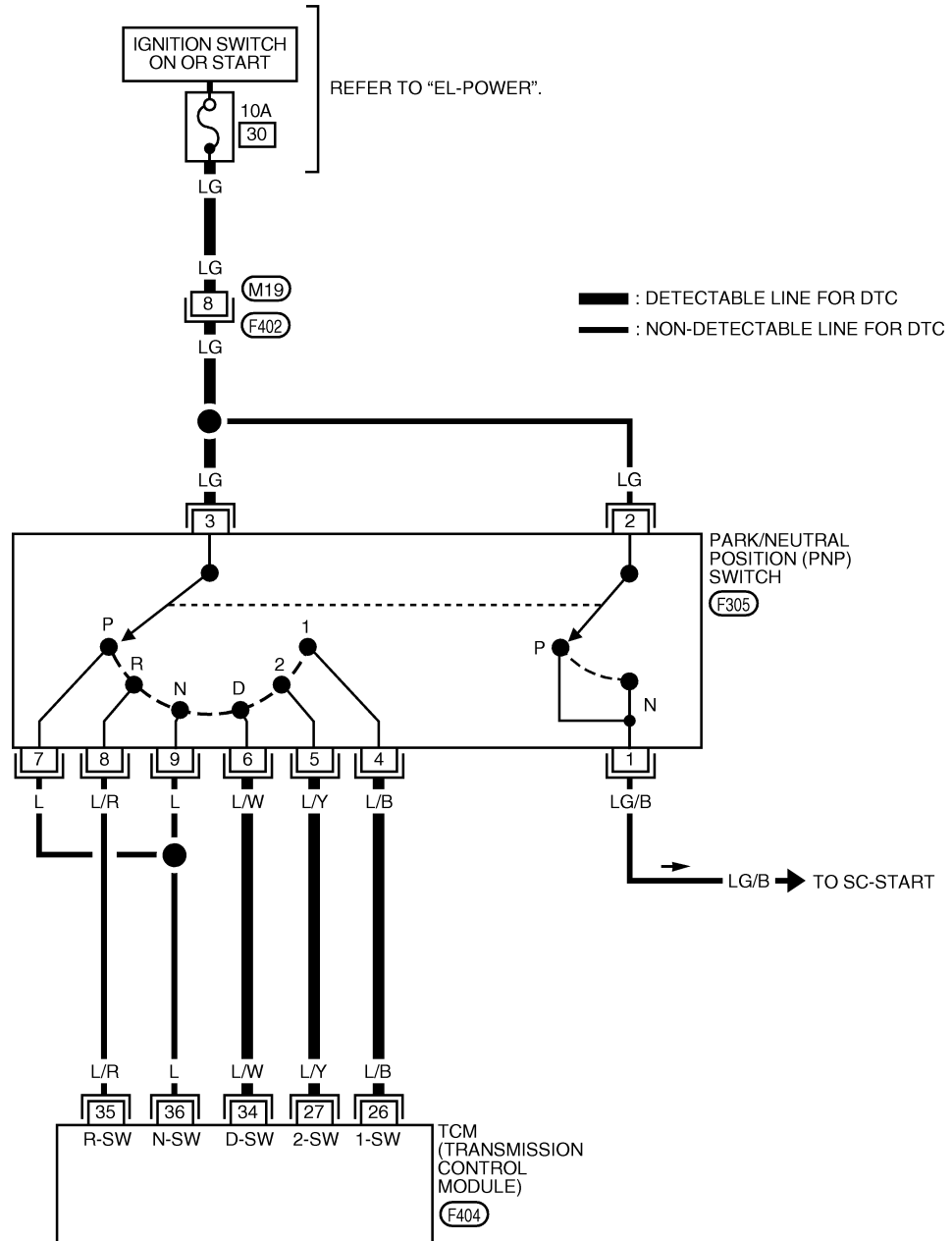

DTC P0705 PARK/NEUTRAL POSITION SWITCH

Diagnostic Procedure

Diagnostic Procedure

NDAT0036

1	CHECK PARK/NEUTRAL POSITION (PNP) SWITCH CIRCUIT (With CONSULT-II)																			
<p> With CONSULT-II</p> <ol style="list-style-type: none"> Turn ignition switch to ON position. (Do not start engine.) Select "TCM INPUT SIGNALS" in "DATA MONITOR" mode for "A/T" with CONSULT-II. Read out P, R, N, D, 2 and 1 position switches moving selector lever to each position. Check the signal of the selector lever position is indicated properly. 																				
<table border="1" style="margin: auto;"> <tr><th colspan="2">SELECT SYSTEM</th></tr> <tr><td style="text-align: center;">A/T</td><td></td></tr> <tr><td style="text-align: center;">ENGINE</td><td></td></tr> <tr><td> </td><td></td></tr> <tr><td> </td><td></td></tr> <tr><td> </td><td></td></tr> <tr><td> </td><td></td></tr> <tr><td> </td><td></td></tr> <tr><td> </td><td></td></tr> </table>			SELECT SYSTEM		A/T		ENGINE													
SELECT SYSTEM																				
A/T																				
ENGINE																				
SAT014K																				
<table border="1" style="margin: auto;"> <tr><th colspan="2">DATA MONITOR</th></tr> <tr><th colspan="2">MONITORING</th></tr> <tr><td>PN POSI SW</td><td style="text-align: center;">OFF</td></tr> <tr><td>R POSITION SW</td><td style="text-align: center;">OFF</td></tr> <tr><td>D POSITION SW</td><td style="text-align: center;">OFF</td></tr> <tr><td>2 POSITION SW</td><td style="text-align: center;">ON</td></tr> <tr><td>1 POSITION SW</td><td style="text-align: center;">OFF</td></tr> </table>			DATA MONITOR		MONITORING		PN POSI SW	OFF	R POSITION SW	OFF	D POSITION SW	OFF	2 POSITION SW	ON	1 POSITION SW	OFF				
DATA MONITOR																				
MONITORING																				
PN POSI SW	OFF																			
R POSITION SW	OFF																			
D POSITION SW	OFF																			
2 POSITION SW	ON																			
1 POSITION SW	OFF																			
SAT701J																				
OK or NG																				
OK	▶	GO TO 3.																		
NG	▶	<p>Check the following items:</p> <ul style="list-style-type: none"> ● Park/neutral position (PNP) switch Refer to "Component Inspection", AT-109. ● Harness for short or open between ignition switch and park/neutral position (PNP) switch (Main harness) ● Harness for short or open between park/neutral position (PNP) switch and TCM (Main harness) ● Ignition switch and fuse Refer to EL-10, "POWER SUPPLY ROUTING". 																		

DTC P0705 PARK/NEUTRAL POSITION SWITCH

Diagnostic Procedure (Cont'd)

GI

MA

EM

LC

EC

FE

AT

AX

SU

BR

ST

RS

BT

HA

SC

EL

IDX

2

CHECK PARK/NEUTRAL POSITION (PNP) SWITCH CIRCUIT (Without CONSULT-II)

⊗ Without CONSULT-II

1. Turn ignition switch to ON position. (Do not start engine.)
2. Check voltage between TCM terminals 26, 27, 34, 35, 36 and ground while moving selector lever through each position.

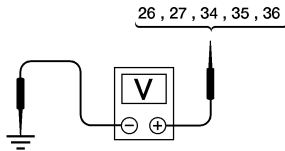
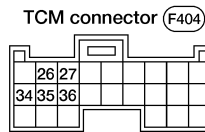
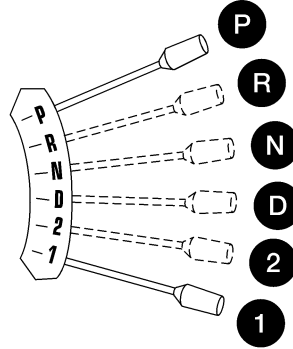

AAT350A

Voltage:
B: Battery voltage
0: 0V

Lever position	Terminal No.				
	36	35	34	27	26
P, N	B	0	0	0	0
R	0	B	0	0	0
D	0	0	B	0	0
2	0	0	0	B	0
1	0	0	0	0	B

MTBL0119

OK or NG

OK



GO TO 3.

NG



Check the following items:

- Park/neutral position (PNP) switch
Refer to "Component Inspection", AT-109.
- Harness for short or open between ignition switch and park/neutral position (PNP) switch (Main harness)
- Harness for short or open between park/neutral position (PNP) switch and TCM (Main harness)
- Ignition switch and fuse
Refer to **EL-10**, "POWER SUPPLY ROUTING".

DTC P0705 PARK/NEUTRAL POSITION SWITCH

Diagnostic Procedure (Cont'd)

3	CHECK DTC
Perform Diagnostic Trouble Code (DTC) confirmation procedure, AT-104.	
OK or NG	
OK	▶ INSPECTION END
NG	▶ 1. Perform TCM input/output signal inspection. 2. If NG, recheck TCM pin terminals for damage or loose connection with harness connector.

DTC P0705 PARK/NEUTRAL POSITION SWITCH

Component Inspection

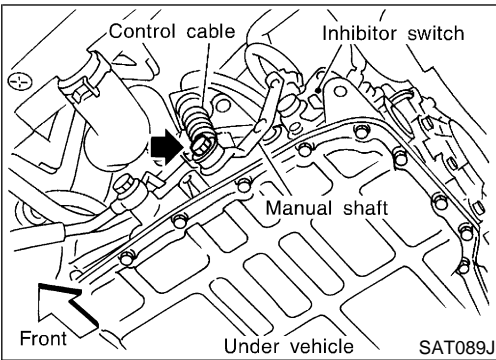
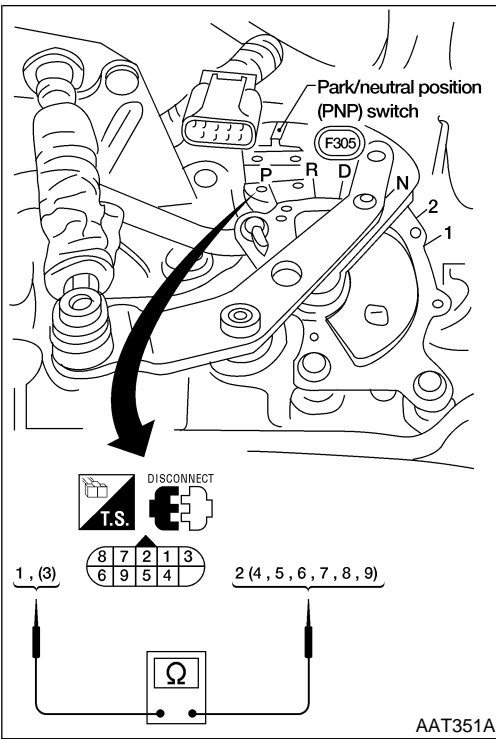

Component Inspection

PARK/NEUTRAL POSITION SWITCH

=NDAT0037

NDAT0037S01

1. Check continuity between terminals 1 and 2 and between terminals 3 and 4, 5, 6, 7, 8, 9 while moving manual shaft through each position.

Lever position	Terminal No.	
P	3 — 7	1 — 2
R	3 — 8	
N	3 — 9	1 — 2
D	3 — 6	
2	3 — 5	
1	3 — 4	

2. If NG, check again with manual control cable disconnected from manual shaft of A/T assembly. Refer to step 1.
3. If OK on step 2, adjust manual control cable. Refer to "Control Cable Adjustment", AT-272.
4. If NG on step 2, remove park/neutral position (PNP) switch from A/T and check continuity of park/neutral position (PNP) switch terminals. Refer to step 1.
5. If OK on step 4, adjust park/neutral position (PNP) switch. Refer to "Park/Neutral Position (PNP) Switch Adjustment", AT-271.
6. If NG on step 4, replace park/neutral position (PNP) switch.

GI

MA

EM

LC

EC

FE

AT

AX

SU

BR

ST

RS

BT

HA

SC

EL

IDX

DTC P0710 A/T FLUID TEMPERATURE SENSOR CIRCUIT

Description

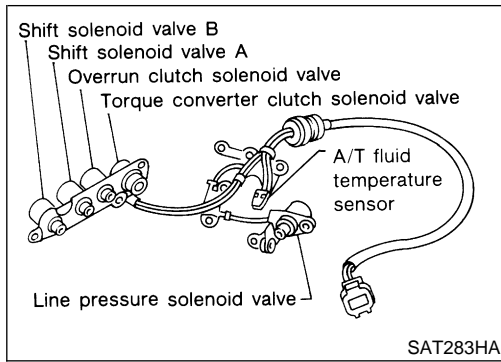

Description

The A/T fluid temperature sensor detects the A/T fluid temperature and sends a signal to the TCM. NDAT0038

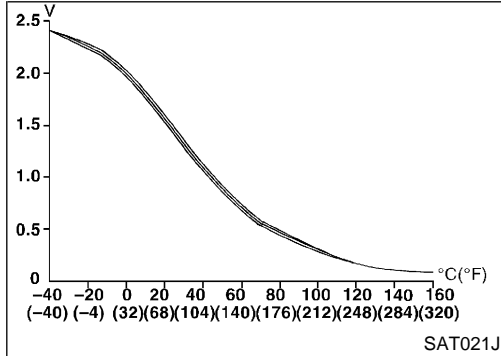



CONSULT-II REFERENCE VALUE IN DATA MONITOR MODE

Remarks: Specification data are reference values. NDAT0038S01

Monitor item	Condition	Specification (Approx.)	
		A/T fluid temperature sensor	Cold [20°C (68°F)] ↓ Hot [80°C (176°F)]

TCM TERMINALS AND REFERENCE VALUE

Remarks: Specification data are reference values. NDAT0038S02

Terminal No.	Wire color	Item	Condition	Judgement standard (Approx.)
42	B/Y	Throttle position sensor (Ground)	—	—
47	SB	A/T fluid temperature sensor	 When ATF temperature is 20°C (68°F).	1.5V
			 When ATF temperature is 80°C (176°F).	0.5V

ON BOARD DIAGNOSIS LOGIC

Diagnostic trouble code	Malfunction is detected when ...	Check items (Possible cause)
ⓘ : ATF TEMP SEN/CIRC ⓘ : P0710 ⓘ : MIL Code No. 1208	TCM receives an excessively low or high voltage from the sensor.	<ul style="list-style-type: none"> • Harness or connectors (The sensor circuit is open or shorted.) • A/T fluid temperature sensor

DTC P0710 A/T FLUID TEMPERATURE SENSOR CIRCUIT

Description (Cont'd)

SELECT SYSTEM
A/T
ENGINE

SAT014K

SELECT DIAG MODE
WORK SUPPORT
SELF-DIAG RESULTS
DATA MONITOR
DATA MONITOR (SPEC)
ACTIVE TEST
DTC & SRT CONFIRMATION

SEF949Y

DIAGNOSTIC TROUBLE CODE (DTC) CONFIRMATION PROCEDURE

NDAT0038S04

CAUTION:

Always drive vehicle at a safe speed.

NOTE:

If "DIAGNOSTIC TROUBLE CODE CONFIRMATION PROCEDURE" has been previously conducted, always turn ignition switch OFF and wait at least 5 seconds before conducting the next test.

After the repair, perform the following procedure to confirm the malfunction is eliminated.

Ⓜ With CONSULT-II

- 1) Turn ignition switch ON and select "DATA MONITOR" mode for "ENGINE" with CONSULT-II.
- 2) Start engine and maintain the following conditions for at least 10 minutes (Total). (It is not necessary to maintain continuously.)

CMPS-RPM (REF): 450 rpm or more

VHCL SPEED SE: 10 km/h (6 MPH) or more

THRTL POS SEN: More than 1.2V

Selector lever: D position (O/D ON)

Ⓜ With GST

Follow the procedure "With CONSULT-II".

GI

MA

EM

LC

EC

FE

AT

AX

SU

BR

ST

RS

BT

HA

SC

EL

IDX

DTC P0710 A/T FLUID TEMPERATURE SENSOR CIRCUIT

Wiring Diagram — AT — FTS

Wiring Diagram — AT — FTS

NDAT0198

AT-FTS-01

: Detectable line for DTC
 : Non-detectable line for DTC

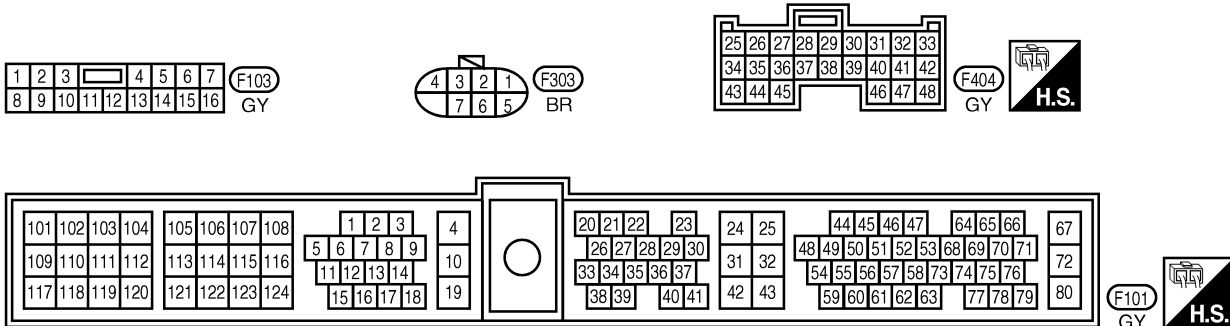
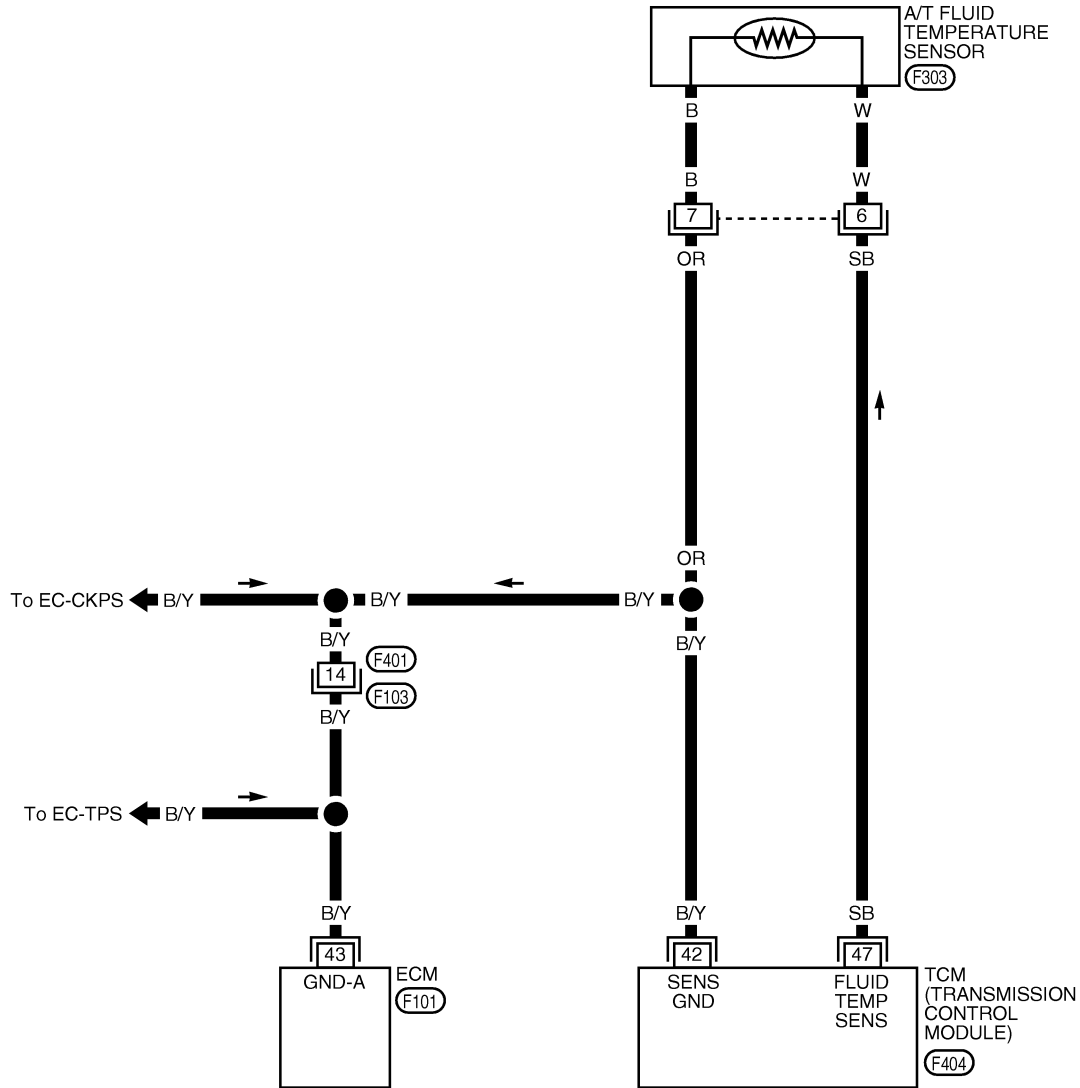

WAT056

DTC P0710 A/T FLUID TEMPERATURE SENSOR CIRCUIT

Diagnostic Procedure

Diagnostic Procedure

NDAT0039

1	INSPECTION START	
Do you have CONSULT-II?		
Yes or No		
Yes	▶	GO TO 2.
No	▶	GO TO 3.

2	CHECK INPUT SIGNAL OF A/T FLUID TEMPERATURE SENSOR (With CONSULT-II)															
<p> With CONSULT-II</p> <p>1. Start engine.</p> <p>2. Select "TCM INPUT SIGNALS" in "DATA MONITOR" mode for "A/T" with CONSULT-II.</p>																
<table border="1" style="margin: auto;"> <tr><th colspan="2">SELECT SYSTEM</th></tr> <tr><td style="text-align: center;">A/T</td></tr> <tr><td style="text-align: center;">ENGINE</td></tr> <tr><td> </td></tr> <tr><td> </td></tr> <tr><td> </td></tr> <tr><td> </td></tr> <tr><td> </td></tr> <tr><td> </td></tr> </table>			SELECT SYSTEM		A/T	ENGINE										
SELECT SYSTEM																
A/T																
ENGINE																
3. Read out the value of "FLUID TEMP SE".																
<table border="1" style="margin: auto;"> <tr><th colspan="2">DATA MONITOR</th></tr> <tr><th colspan="2">MONITORING</th></tr> <tr><td>VHCL/S SE-A/T</td><td>XXX km/h</td></tr> <tr><td>VHCL/S SE-MTR</td><td>XXX km/h</td></tr> <tr><td>THRTL POS SEN</td><td>XXX V</td></tr> <tr><td>FLUID TEMP SE</td><td>XXX V</td></tr> <tr><td>BATTERY VOLT</td><td>XXX V</td></tr> </table>			DATA MONITOR		MONITORING		VHCL/S SE-A/T	XXX km/h	VHCL/S SE-MTR	XXX km/h	THRTL POS SEN	XXX V	FLUID TEMP SE	XXX V	BATTERY VOLT	XXX V
DATA MONITOR																
MONITORING																
VHCL/S SE-A/T	XXX km/h															
VHCL/S SE-MTR	XXX km/h															
THRTL POS SEN	XXX V															
FLUID TEMP SE	XXX V															
BATTERY VOLT	XXX V															
<p>Voltage: Cold [20°C (68°F)] → Hot [80°C (176°F)]: Approximately 1.5V → 0.5V</p>																
OK or NG																
OK	▶	GO TO 4.														
NG	▶	GO TO 5.														

GI

MA

EM

LC

EC

FE

AT

AX

SU

SAT014K

BR

ST

RS

BT

SAT614J

HA

SC

EL

IDX

DTC P0710 A/T FLUID TEMPERATURE SENSOR CIRCUIT

Diagnostic Procedure (Cont'd)

3	CHECK INPUT SIGNAL OF A/T FLUID TEMPERATURE SENSOR (Without CONSULT-II)	
<p>⊗ Without CONSULT-II</p> <ol style="list-style-type: none"> Start engine. Check voltage between TCM terminal 47 and ground while warming up A/T. 		
<p>Voltage: Cold [20°C (68°F)] → Hot [80°C (176°F)]: Approximately 1.5V → 0.5V</p>		
<ol style="list-style-type: none"> Turn ignition switch to OFF position. Disconnect TCM harness connector. Check continuity between terminal 47 and ground. 		
<p>Continuity should exist. If OK, check harness for short to ground and short to power.</p> <p style="text-align: center;">OK or NG</p>		
OK	▶	GO TO 4.
NG	▶	GO TO 5.

AAT353A

AAT354A

4	CHECK DTC	
<p>Perform "DIAGNOSTIC TROUBLE CODE (DTC) CONFIRMATION PROCEDURE", AT-111.</p> <p style="text-align: center;">OK or NG</p>		
OK	▶	INSPECTION END
NG	▶	<ol style="list-style-type: none"> Perform TCM input/output signal inspection. If NG, recheck TCM pin terminals for damage or loose connection with harness connector.

DTC P0710 A/T FLUID TEMPERATURE SENSOR CIRCUIT

Diagnostic Procedure (Cont'd)

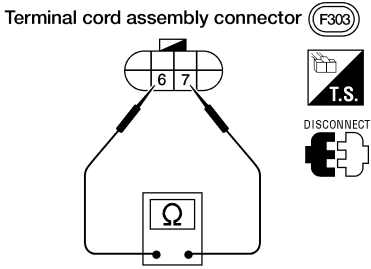
5	CHECK A/T FLUID TEMPERATURE SENSOR WITH TERMINAL CORD ASSEMBLY	
	<p>1. Turn ignition switch to OFF position. 2. Disconnect terminal cord assembly connector in engine compartment. 3. Check resistance between terminals 6 and 7 when A/T is cold.</p> <div style="text-align: center;">  <p>Terminal cord assembly connector (F303)</p> </div> <p>Resistance: Cold [20°C (68°F)] Approximately 2.5 kΩ</p> <p>4. Reinstall any part removed.</p> <p style="text-align: center;">OK or NG</p>	
OK (with CONSULT-II)	▶	GO TO 2.
OK (without CONSULT-II)	▶	GO TO 3.
NG	▶	<p>1. Remove oil pan. 2. Check the following items:</p> <ul style="list-style-type: none"> ● A/T fluid temperature sensor Refer to "Component Inspection", AT-116. ● Harness of terminal cord assembly for short or open

GI
 MA
 EM
 LC
 EC
 FE
AT
 AX
 SU
 BR
 ST
 RS
 BT
 HA
 SC
 EL
 IDX

DTC P0710 A/T FLUID TEMPERATURE SENSOR CIRCUIT

Component Inspection

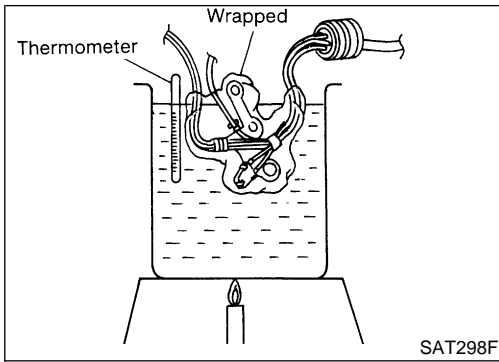

Component Inspection

A/T FLUID TEMPERATURE SENSOR

=NDAT0040

NDAT0040S01

- For removal, refer to "Control Valve Assembly and Accumulators", AT-270.
- Check resistance between two terminals while changing temperature as shown at left.

Temperature °C (°F)	Resistance (Approx.)
20 (68)	2.5 kΩ
80 (176)	0.3 kΩ

DTC P0720 VEHICLE SPEED SENSOR-A/T (REVOLUTION SENSOR)

Description

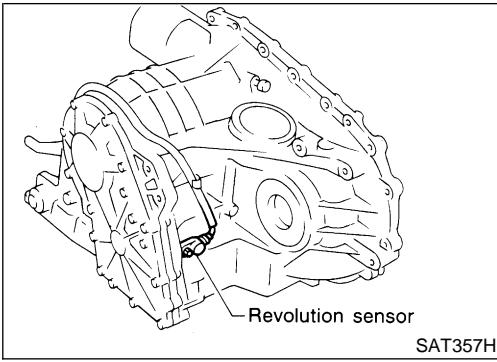

Description

The revolution sensor detects the revolution of the idler gear parking pawl lock gear and emits a pulse signal. The pulse signal is sent to the TCM which converts it into vehicle speed.

NDAT0041

TCM TERMINALS AND REFERENCE VALUE

NDAT0041S01

Remarks: Specification data are reference values.

Terminal No.	Wire color	Item	Condition		Judgement standard (Approx.)
29	W	Revolution sensor (Measure in AC range)		When vehicle cruises at 30 km/h (19 MPH).	1V or more Voltage rises gradually in response to vehicle speed.
				When vehicle parks.	0V
42	B/Y	Throttle position sensor (Ground)		—	—

ON BOARD DIAGNOSIS LOGIC

NDAT0041S02

Diagnostic trouble code	Malfunction is detected when ...	Check items (Possible cause)
(P) : VEH SPD SEN/CIR AT (G) : P0720 (NO TOOLS) : MIL Code No. 1102	TCM does not receive the proper voltage signal from the sensor.	<ul style="list-style-type: none"> • Harness or connectors (The sensor circuit is open or shorted.) • Revolution sensor

DTC P0720 VEHICLE SPEED SENSOR-A/T (REVOLUTION SENSOR)

Description (Cont'd)

SELECT SYSTEM
A/T
ENGINE

SAT014K

SELECT DIAG MODE
SELF-DIAG RESULTS
DATA MONITOR
DTC WORK SUPPORT
TCM PART NUMBER

SAT971J

SELECT SYSTEM
A/T
ENGINE

SAT014K

SELECT DIAG MODE
WORK SUPPORT
SELF-DIAG RESULTS
DATA MONITOR
DATA MONITOR (SPEC)
ACTIVE TEST
DTC & SRT CONFIRMATION

SEF949Y

DIAGNOSTIC TROUBLE CODE (DTC) CONFIRMATION PROCEDURE

NDAT0041S03

CAUTION:

- Always drive vehicle at a safe speed.
- Be careful not to rev engine into the red zone on the tachometer.

NOTE:

If "DIAGNOSTIC TROUBLE CODE CONFIRMATION PROCEDURE" has been previously conducted, always turn ignition switch OFF and wait at least 5 seconds before conducting the next test. After the repair, perform the following procedure to confirm the malfunction is eliminated.

With CONSULT-II

- 1) Turn ignition switch ON and select "TCM INPUT SIGNALS" in "DATA MONITOR" mode for "A/T" with CONSULT-II.
- 2) Drive vehicle and check for an increase of "VHCL/S SE-A/T" value in response to "VHCL/S SE-MTR" value.
If the check result is NG, go to "DIAGNOSTIC PROCEDURE", AT-206.
If the check result is OK, go to following step.
- 3) Select "DATA MONITOR" mode for "ENGINE" with CONSULT-II.
- 4) Start engine and maintain the following conditions for at least 5 consecutive seconds.
VHCL SPEED SE: 30 km/h (19 MPH) or more
THRTL POS SEN: More than 1.2V
Selector lever: D position (O/D ON)
Driving location: Driving the vehicle uphill (increased engine load) will help maintain the driving conditions required for this test.
If the check result is NG, go to "DIAGNOSTIC PROCEDURE", AT-120.
If the check result is OK, go to following step.
- 5) Maintain the following conditions for at least 5 consecutive seconds.
CMPS-RPM (REF): 3,500 rpm or more
THRTL POS SEN: More than 1.2V
Selector lever: D position (O/D ON)
Driving location: Driving the vehicle uphill (increased engine load) will help maintain the driving conditions required for this test.

With GST

Follow the procedure "With CONSULT-II".

DTC P0720 VEHICLE SPEED SENSOR-A/T (REVOLUTION SENSOR)

Wiring Diagram — AT — VSSA/T

Wiring Diagram — AT — VSSA/T

NDAT0199

AT-VSSAT-01

GI

MA

EM

LC

EC

FE

AT

AX

SU

BR

ST

RS

BT

HA

SC

EL

IDX

— : Detectable line for DTC
 - - - : Non-detectable line for DTC

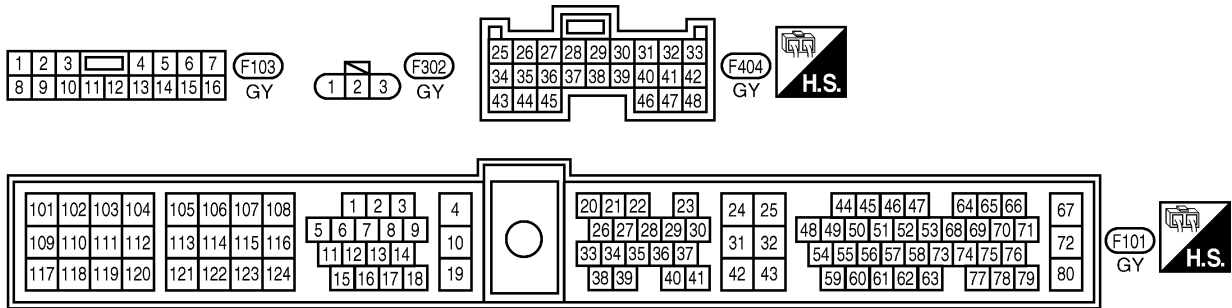
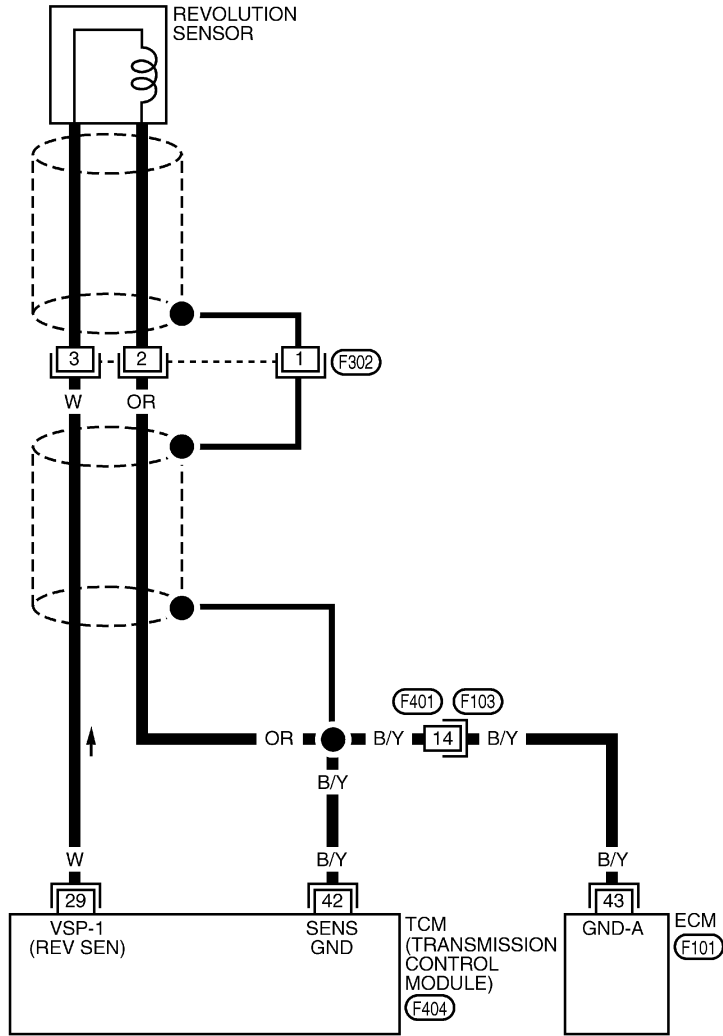

DTC P0720 VEHICLE SPEED SENSOR-A/T (REVOLUTION SENSOR)

Diagnostic Procedure

Diagnostic Procedure

NDAT0042

1	CHECK INPUT SIGNAL (With CONSULT-II)														
<p> With CONSULT-II</p> <p>1. Start engine.</p> <p>2. Select "TCM INPUT SIGNALS" in "DATA MONITOR" mode for "A/T" with CONSULT-II.</p>															
<table border="1" style="margin: auto;"> <tr><td style="text-align: center;">SELECT SYSTEM</td></tr> <tr><td style="text-align: center;">A/T</td></tr> <tr><td style="text-align: center;">ENGINE</td></tr> <tr><td style="text-align: center;"> </td></tr> <tr><td style="text-align: center;"> </td></tr> <tr><td style="text-align: center;"> </td></tr> <tr><td style="text-align: center;"> </td></tr> <tr><td style="text-align: center;"> </td></tr> </table>		SELECT SYSTEM	A/T	ENGINE											
SELECT SYSTEM															
A/T															
ENGINE															
<p>3. Read out the value of "VHCL/S SE-A/T" while driving. Check the value changes according to driving speed.</p>															
<table border="1" style="margin: auto;"> <tr><td colspan="2" style="text-align: center;">DATA MONITOR</td></tr> <tr><td style="text-align: center;">MONITORING</td><td style="text-align: center;"> </td></tr> <tr><td>VHCL/S SE-A/T</td><td>XXX km/h</td></tr> <tr><td>VHCL/S SE-MTR</td><td>XXX km/h</td></tr> <tr><td>THRTL POS SEN</td><td>XXX V</td></tr> <tr><td>FLUID TEMP SE</td><td>XXX V</td></tr> <tr><td>BATTERY VOLT</td><td>XXX V</td></tr> </table>		DATA MONITOR		MONITORING		VHCL/S SE-A/T	XXX km/h	VHCL/S SE-MTR	XXX km/h	THRTL POS SEN	XXX V	FLUID TEMP SE	XXX V	BATTERY VOLT	XXX V
DATA MONITOR															
MONITORING															
VHCL/S SE-A/T	XXX km/h														
VHCL/S SE-MTR	XXX km/h														
THRTL POS SEN	XXX V														
FLUID TEMP SE	XXX V														
BATTERY VOLT	XXX V														
OK or NG															
OK	▶ GO TO 4.														
NG	▶ GO TO 3.														

SAT014K

SAT614J

DTC P0720 VEHICLE SPEED SENSOR-A/T (REVOLUTION SENSOR)

Diagnostic Procedure (Cont'd)

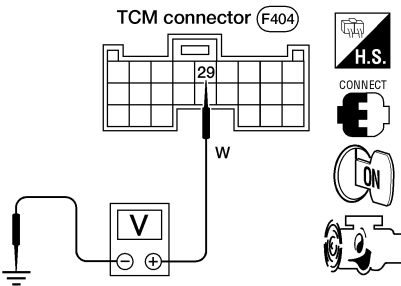
2	CHECK INPUT SIGNAL (Without CONSULT-II)	
<p>⊗ Without CONSULT-II</p> <ol style="list-style-type: none"> Start engine. Check voltage between TCM terminal 29 and ground while driving. (Measure with AC range.) 		
		
<p>Voltage: At 0 km/h (0 MPH): 0V At 30 km/h (19 MPH): 1V or more (Voltage rises gradually in response to vehicle speed.)</p>		
AAT355A		
OK or NG		
OK	▶	GO TO 4.
NG	▶	GO TO 3.

3	CHECK REVOLUTION SENSOR	
Refer to "Component Inspection", AT-122.		
OK or NG		
OK (with CONSULT-II)	▶	GO TO 1.
OK (without CONSULT-II)	▶	GO TO 2.
NG	▶	Repair or replace revolution sensor.

4	CHECK DTC	
Perform "DIAGNOSTIC TROUBLE CODE (DTC) CONFIRMATION PROCEDURE", AT-118.		
OK or NG		
OK	▶	INSPECTION END
NG	▶	<ol style="list-style-type: none"> Perform TCM input/output signal inspection. If NG, recheck TCM pin terminals for damage or loose connection with harness connector.

GI

MA

EM

LC

EC

FE

AT

AX

SU

BR

ST

RS

BT

HA

SC

EL

IDX

DTC P0720 VEHICLE SPEED SENSOR-A/T (REVOLUTION SENSOR)

Component Inspection

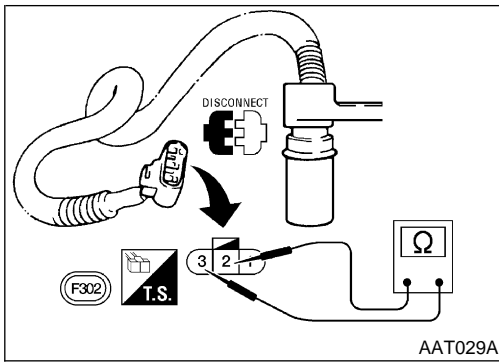

Component Inspection REVOLUTION SENSOR

=NDAT0043

NDAT0043S02

- For removal, refer to "Revolution Sensor Replacement", AT-271.
- Check resistance between terminals 1, 2 and 3.

Terminal No.	Resistance
2 - 3	500 - 650Ω
1 - 2	No continuity
1 - 3	No continuity

DTC P0725 ENGINE SPEED SIGNAL

Description



Description

The engine speed signal is sent from the ECM to the TCM. NDAT0044

TCM TERMINALS AND REFERENCE VALUE



NDAT0044S01

Remarks: Specification data are reference values.

Terminal No.	Wire color	Item	Condition	Judgement standard (Approx.)
39	G/W	Engine speed signal	 When engine runs at idle speed.	0.6V
			 When engine runs at 4,000 rpm.	1.6V

ON BOARD DIAGNOSIS LOGIC

NDAT0044S02

Diagnostic trouble code	Malfunction is detected when ...	Check item (Possible cause)
 : ENGINE SPEED SIG	TCM does not receive the proper voltage signal from ECM.	<ul style="list-style-type: none"> Harness or connectors (The sensor circuit is open or shorted.)
 : P0725		
 : MIL Code No. 1207		

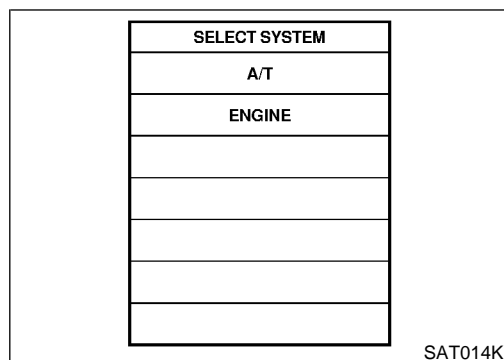

DIAGNOSTIC TROUBLE CODE (DTC) CONFIRMATION PROCEDURE

NDAT0044S03

CAUTION:

Always drive vehicle at a safe speed.

NOTE:

If "DIAGNOSTIC TROUBLE CODE CONFIRMATION PROCEDURE" has been previously conducted, always turn ignition switch OFF and wait at least 5 seconds before conducting the next test.

After the repair, perform the following procedure to confirm the malfunction is eliminated.

With CONSULT-II

- Turn ignition switch ON and select "DATA MONITOR" mode for "ENGINE" with CONSULT-II.
- Start engine and maintain the following conditions for at least 10 consecutive seconds.

VHCL SPEED SE: 10 km/h (6 MPH) or more

THRTL POS SEN: More than 1.2V

Selector lever: D position (O/D ON)

With GST

Follow the procedure "With CONSULT-II".

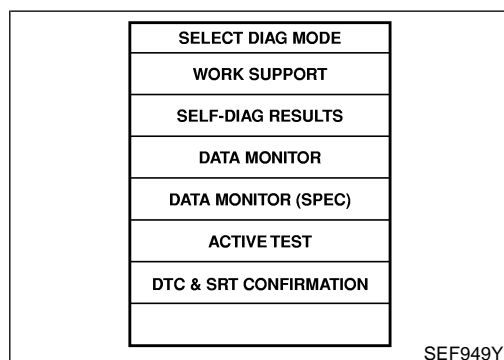

DTC P0725 ENGINE SPEED SIGNAL

Wiring Diagram — AT — ENGSS

Wiring Diagram — AT — ENGSS

NDAT0200

AT-ENGSS-01

: DETECTABLE LINE FOR DTC
 : NON-DETECTABLE LINE FOR DTC

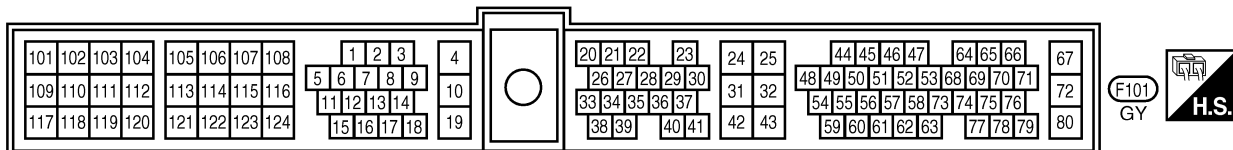
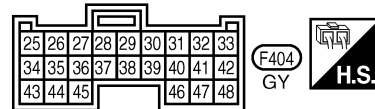
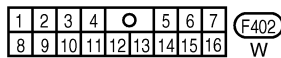
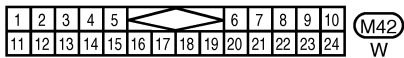
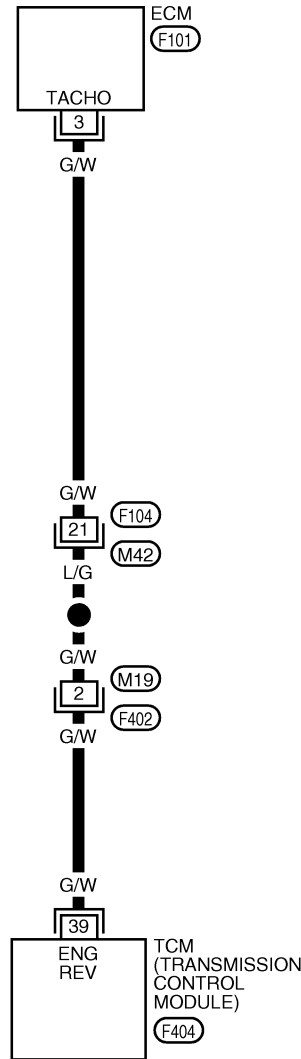

LAT323

DTC P0725 ENGINE SPEED SIGNAL

Diagnostic Procedure

Diagnostic Procedure

NDAT0045

1	CHECK DTC WITH ECM	
Perform diagnostic test mode II (self-diagnostic results) for engine control. Check ignition signal circuit condition.		
OK or NG		
OK (with CONSULT-II)	▶	GO TO 2.
OK (without CONSULT-II)	▶	GO TO 3.
NG	▶	Check ignition signal circuit for engine control. Refer to "Ignition Signal (DTC: 0201)", EC-408 .

GI

MA

EM

LC

2	CHECK INPUT SIGNAL (With CONSULT-II)																	
<p>Ⓜ With CONSULT-II</p> <p>1. Start engine.</p> <p>2. Select "TCM INPUT SIGNALS" in "DATA MONITOR" mode for "A/T" with CONSULT-II.</p>																		
<table border="1" style="margin: auto;"> <tr><th colspan="2">SELECT SYSTEM</th></tr> <tr><td style="text-align: center;">A/T</td><td></td></tr> <tr><td style="text-align: center;">ENGINE</td><td></td></tr> <tr><td> </td><td></td></tr> <tr><td> </td><td></td></tr> <tr><td> </td><td></td></tr> <tr><td> </td><td></td></tr> <tr><td> </td><td></td></tr> </table>			SELECT SYSTEM		A/T		ENGINE											
SELECT SYSTEM																		
A/T																		
ENGINE																		
<p>3. Read out the value of "ENGINE SPEED". Check engine speed changes according to throttle position.</p>																		
<table border="1" style="margin: auto;"> <tr><th colspan="2">DATA MONITOR</th></tr> <tr><th colspan="2">MONITORING</th></tr> <tr><td>ENGINE SPEED</td><td>XXX rpm</td></tr> <tr><td>TURBINE REV</td><td>XXX rpm</td></tr> <tr><td>OVERDRIVE SW</td><td>ON</td></tr> <tr><td>PN POSI SW</td><td>OFF</td></tr> <tr><td>R POSITION SW</td><td>OFF</td></tr> </table>			DATA MONITOR		MONITORING		ENGINE SPEED	XXX rpm	TURBINE REV	XXX rpm	OVERDRIVE SW	ON	PN POSI SW	OFF	R POSITION SW	OFF		
DATA MONITOR																		
MONITORING																		
ENGINE SPEED	XXX rpm																	
TURBINE REV	XXX rpm																	
OVERDRIVE SW	ON																	
PN POSI SW	OFF																	
R POSITION SW	OFF																	
OK or NG																		
OK	▶	GO TO 4.																
NG	▶	<p>Check the following items:</p> <ul style="list-style-type: none"> ● Harness for short or open between TCM and ECM ● Resistor and ignition coil <p>Refer to EC-408, "Ignition Signal (DTC: 0201)".</p>																

EC

FE

AT

AX

SU

SAT014K

BR

ST

RS

BT

HA

SAT645J

SC

EL

IDX

DTC P0725 ENGINE SPEED SIGNAL

Diagnostic Procedure (Cont'd)

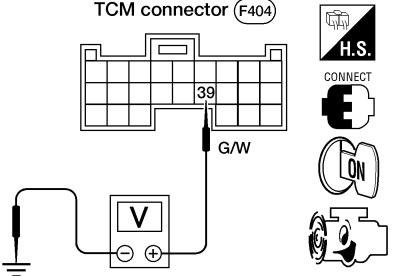
3	CHECK INPUT SIGNAL (Without CONSULT-II)	
<p>⊗ Without CONSULT-II</p> <ol style="list-style-type: none"> 1. Start engine. 2. Check voltage between TCM terminal 39 and ground. 		
		
<p>Voltage: 0.6 (Idle speed) - 1.6V (4,000 rpm)</p> <p style="text-align: center;">OK or NG</p>		
OK	▶	GO TO 4.
NG	▶	<p>Check the following items:</p> <ul style="list-style-type: none"> ● Harness for short or open between TCM and ECM ● Resistor and ignition coil <p>Refer to EC-408, "Ignition Signal (DTC: 0201)".</p>

AAT356A

4	CHECK DTC	
Perform "DIAGNOSTIC TROUBLE CODE (DTC) CONFIRMATION PROCEDURE", AT-123.		
OK or NG		
OK	▶	INSPECTION END
NG	▶	<ol style="list-style-type: none"> 1. Perform TCM input/output signal inspection. 2. If NG, recheck TCM pin terminals for damage or loose connection with harness connector.

DTC P0731 A/T 1ST GEAR FUNCTION

Description

Description

- This is an OBD-II self-diagnostic item and not available in TCM self-diagnosis. NDAT0046
- This malfunction will not be detected while the O/D OFF indicator lamp is indicating another self-diagnosis malfunction.
- This malfunction is detected when the A/T does not shift into first gear position as instructed by the TCM. This is not caused by electrical malfunction (circuits open or shorted) but by mechanical malfunction such as control valve sticking, improper solenoid valve operation, etc.

Gear position	1	2	3	4
Shift solenoid valve A	ON (Closed)	OFF (Open)	OFF (Open)	ON (Closed)
Shift solenoid valve B	ON (Closed)	ON (Closed)	OFF (Open)	OFF (Open)

TCM TERMINALS AND REFERENCE VALUE

NDAT0046S01

Remarks: Specification data are reference values.

Terminal No.	Wire color	Item	Condition	Judgement standard (Approx.)
11	Y/PU	Shift solenoid valve A	When shift solenoid valve A operates. (When driving in D ₁ or D ₄ .)	Battery voltage
			When shift solenoid valve A does not operate. (When driving in D ₂ or D ₃ .)	0V
12	Y/G	Shift solenoid valve B	When shift solenoid valve B operates. (When driving in D ₁ or D ₂ .)	Battery voltage
			When shift solenoid valve B does not operate. (When driving in D ₃ or D ₄ .)	0V



ON BOARD DIAGNOSTIC LOGIC

NDAT0046S02

This diagnosis monitors actual gear position by checking the torque converter slip ratio calculated by TCM as follows:

Torque converter slip ratio = A x C/B

A: Output shaft revolution signal from revolution sensor

B: Engine speed signal from ECM

C: Gear ratio determined as gear position which TCM supposes
If the actual gear position is higher than the position (1st) supposed by TCM, the slip ratio will be more than normal. In case the ratio exceeds the specified value, TCM judges this diagnosis malfunction.



This malfunction will be caused when either shift solenoid valve A is stuck open or shift solenoid valve B is stuck open.

Gear position supposed by TCM	1	2	3	4
In case of gear position with no malfunctions	1	2	3	4
In case of gear position with shift solenoid valve A stuck open	2*	2	3	3
In case of gear position with shift solenoid valve B stuck open	4*	3	3	4

*: P0731 is detected.

DTC P0731 A/T 1ST GEAR FUNCTION

Description (Cont'd)

Diagnostic trouble code	Malfunction is detected when ...	Check items (Possible cause)
 : A/T 1ST GR FNCTN  : P0731  : MIL Code No. 1103	A/T cannot be shifted to the 1st gear position even if electrical circuit is good.	<ul style="list-style-type: none"> ● Shift solenoid valve A ● Shift solenoid valve B ● Each clutch ● Hydraulic control circuit

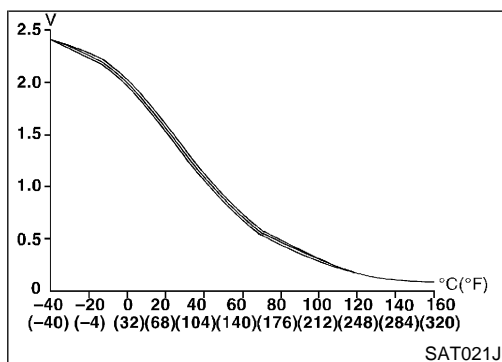
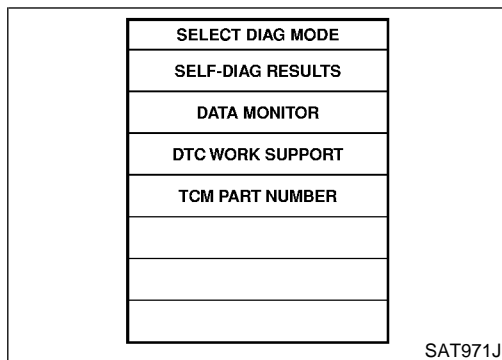
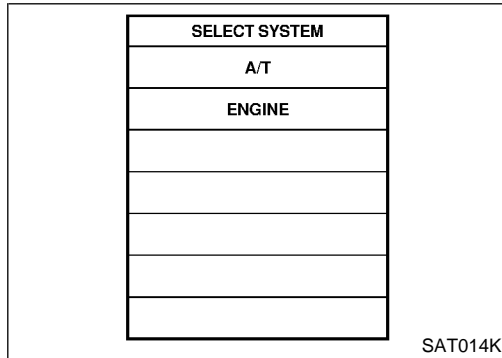

DIAGNOSTIC TROUBLE CODE (DTC) CONFIRMATION PROCEDURE

NDAT0046S03

CAUTION:

- Always drive vehicle at a safe speed.
- Be careful not to rev engine into the red zone on the tachometer.

NOTE:

If "DIAGNOSTIC TROUBLE CODE CONFIRMATION PROCEDURE" has been previously conducted, always turn ignition switch OFF and wait at least 5 seconds before conducting the next test.

TESTING CONDITION:

Always drive vehicle on a level road to improve the accuracy of test.

After the repair, perform the following procedure to confirm the malfunction is eliminated.

With CONSULT-II

- 1) Start engine and select "TCM INPUT SIGNAL" in "DATA MONITOR" mode for "A/T" with CONSULT-II.
- 2) Make sure that output voltage of A/T fluid temperature sensor is within the range below.

FLUID TEMP SEN: 0.4 - 1.5V

If out of range, drive the vehicle to decrease the voltage (warm up the fluid) or stop engine to increase the voltage (cool down the fluid).

- 3) Select "1ST GR FNCTN P0731" of "DTC WORK SUPPORT" mode for "A/T" with CONSULT-II and touch "START".
- 4) Accelerate vehicle to 20 to 25 km/h (12 to 16 MPH) under the following condition and release the accelerator pedal completely.

THROTTLE POSI: Less than 1.0/8 (at all times during step 4)

Selector lever: D position (O/D ON)

- Check that "GEAR" shows "2" after releasing pedal.
- 5) Depress accelerator pedal to WOT (more than 7.0/8 of "THROTTLE POSI") quickly from a speed of 20 to 25 km/h (12 to 16 MPH) until "TESTING" changes to "STOP VEHICLE" or "COMPLETED". (It will take approximately 3 seconds.)
If the check result NG appears on CONSULT-II screen, go to "DIAGNOSTIC PROCEDURE", AT-131.
If "STOP VEHICLE" appears on CONSULT-II screen, go to the following step.

- Check that "GEAR" shows "1" when depressing accelerator pedal to WOT.
- If "TESTING" does not appear on CONSULT-II for a long time, select "SELF-DIAGNOSIS" for "ENGINE". In case a 1st trip DTC other than P0731 is shown, refer to applicable

DTC P0731 A/T 1ST GEAR FUNCTION

Description (Cont'd)

“TROUBLE DIAGNOSIS FOR DTC”.

- 6) Stop vehicle.
- 7) Follow the instruction displayed. (Check for normal shifting referring to the table below.)

Vehicle condition	Gear on actual transmission shift pattern when screen is changed to 1 → 2 → 3 → 4
No malfunction exists	1 → 2 → 3 → 4
Malfunction for P0731 exists.	2 → 2 → 3 → 3
	4 → 3 → 3 → 4

- 8) Make sure that “OK” is displayed. (If “NG” is displayed, refer to “DIAGNOSTIC PROCEDURE”.)
Refer to “DIAGNOSTIC PROCEDURE”, AT-131.
Refer to shift schedule, AT-370.

 **With GST**

Follow the procedure “With CONSULT-II”.

GI

MA

EM

LC

EC

FE

AT

AX

SU

BR

ST

RS

BT

HA

SC

EL

IDX

DTC P0731 A/T 1ST GEAR FUNCTION

Wiring Diagram — AT — 1ST

Wiring Diagram — AT — 1ST

NDAT0201

AT-1STSIG-01

: Detectable line for DTC
 : Non-detectable line for DTC

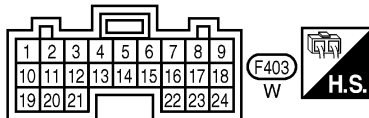
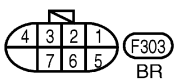
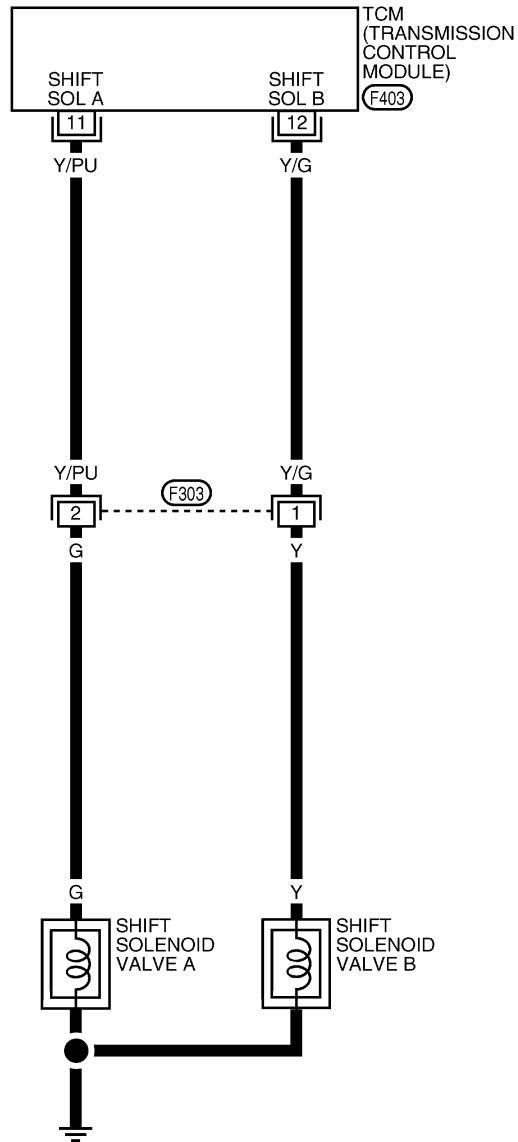

AAT278A

DTC P0731 A/T 1ST GEAR FUNCTION

Diagnostic Procedure

Diagnostic Procedure

NDAT0047

1	CHECK SHIFT SOLENOID VALVE	
<p>1. Remove control valve assembly. Refer to AT-270. 2. Check shift solenoid valve operation.</p> <ul style="list-style-type: none"> ● Shift solenoid valve A ● Shift solenoid valve B <p>Refer to "Component Inspection", AT-132.</p> <p style="text-align: center;">OK or NG</p>		
OK	▶	GO TO 2.
NG	▶	Repair or replace shift solenoid valve assembly.

GI
MA
EM
LC

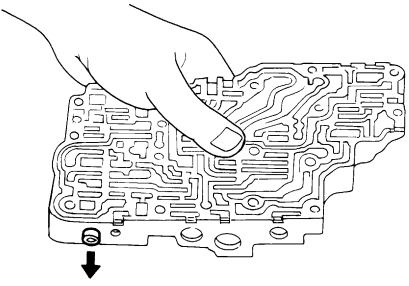
2	CHECK CONTROL VALVE	
<p>1. Disassemble control valve assembly. Refer to "Control Valve Assembly", AT-302. 2. Check to ensure that:</p> <ul style="list-style-type: none"> ● Valve, sleeve and plug slide along valve bore under their own weight. ● Valve, sleeve and plug are free from burrs, dents and scratches. ● Control valve springs are free from damage, deformation and fatigue. ● Hydraulic line is free from obstacles. <div style="text-align: center;">  </div> <p style="text-align: right;">SAT367H</p> <p style="text-align: center;">OK or NG</p>		
OK	▶	GO TO 3.
NG	▶	Repair control valve assembly.

EC
FE

AT

AX
SU
BR
ST

RS
BT

3	CHECK DTC	
<p>Perform "DIAGNOSTIC TROUBLE CODE (DTC) CONFIRMATION PROCEDURE", AT-128.</p> <p style="text-align: center;">OK or NG</p>		
OK	▶	INSPECTION END
NG	▶	Check control valve again. Repair or replace control valve assembly.

HA
SC

EL

IDX

DTC P0731 A/T 1ST GEAR FUNCTION

Component Inspection

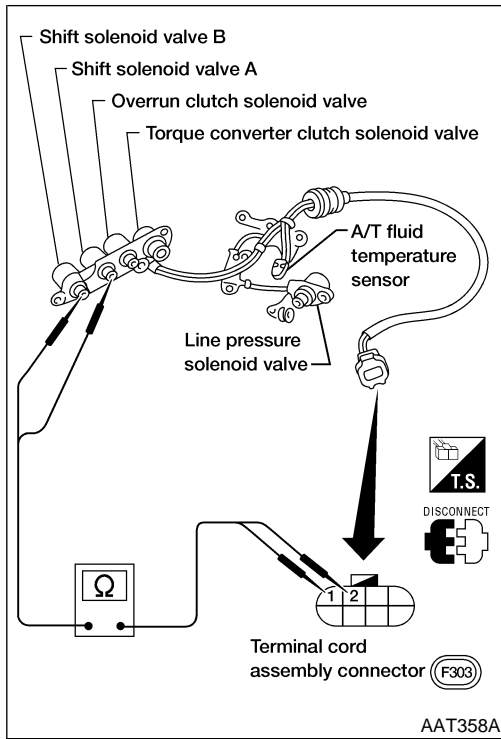

Component Inspection

SHIFT SOLENOID VALVE A AND B

=NDAT0048

NDAT0048S01

- For removal, refer to "Control Valve Assembly and Accumulators", AT-270.

Resistance Check

NDAT0048S0101

- Check resistance between two terminals.

Solenoid valve	Terminal No.		Resistance (Approx.)
Shift solenoid valve A	2	Ground	20 - 40Ω
Shift solenoid valve B	1		

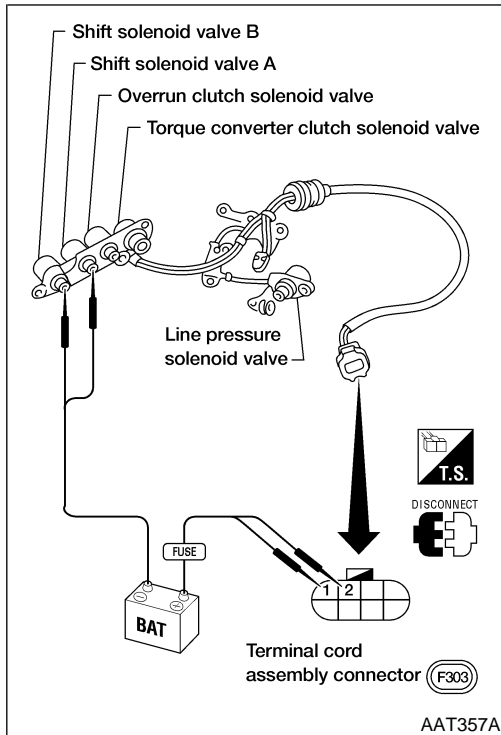

Operation Check

NDAT0048S0102

- Check solenoid valve by listening for its operating sound while applying battery voltage to the terminal and ground.

DTC P0732 A/T 2ND GEAR FUNCTION

Description

Description

- This is an OBD-II self-diagnostic item and not available in TCM self-diagnosis. NDAT0049
- This malfunction will not be detected while the O/D OFF indicator lamp is indicating another self-diagnosis malfunction. GI
- This malfunction is detected when the A/T does not shift into second gear position as instructed by the TCM. This is not caused by electrical malfunction (circuits open or shorted) but by mechanical malfunction such as control valve sticking, improper solenoid valve operation, etc. MA

Gear position	1	2	3	4
Shift solenoid valve A	ON (Closed)	OFF (Open)	OFF (Open)	ON (Closed)
Shift solenoid valve B	ON (Closed)	ON (Closed)	OFF (Open)	OFF (Open)

TCM TERMINALS AND REFERENCE VALUE

NDAT0049S01

Remarks: Specification data are reference values.

Terminal No.	Wire color	Item	Condition	Judgement standard (Approx.)
12	Y/G	Shift solenoid valve B	 When shift solenoid valve B operates. (When driving in D ₁ or D ₂ .)	Battery voltage
			When shift solenoid valve B does not operate. (When driving in D ₃ or D ₄ .)	0V

ON BOARD DIAGNOSTIC LOGIC

NDAT0049S02

This diagnosis monitors actual gear position by checking the torque converter slip ratio calculated by TCM as follows:

Torque converter slip ratio = A x C/B

A: Output shaft revolution signal from revolution sensor



B: Engine speed signal from ECM

C: Gear ratio determined as gear position which TCM supposes
If the actual gear position is higher than the position (2nd) supposed by TCM, the slip ratio will be more than normal. In case the ratio exceeds the specified value, TCM judges this diagnosis malfunction. ST

This malfunction will be caused when shift solenoid valve B is stuck open. RS

Gear position supposed by TCM	1	2	3	4
In case of gear position with no malfunctions	1	2	3	4
In case of gear position with shift solenoid valve B stuck open	4	3*	3	4

*: P0732 is detected. BT

Diagnostic trouble code	Malfunction is detected when ...	Check items (Possible cause)
 : A/T 2ND GR FNCTN	A/T cannot be shifted to the 2nd gear position even if electrical circuit is good.	<ul style="list-style-type: none"> • Shift solenoid valve B • Each clutch • Hydraulic control circuit
 : P0732		
 : MIL Code No. 1104		

DTC P0732 A/T 2ND GEAR FUNCTION

Description (Cont'd)

SELECT SYSTEM
A/T
ENGINE

SAT014K

SELECT DIAG MODE
SELF-DIAG RESULTS
DATA MONITOR
DTC WORK SUPPORT
TCM PART NUMBER

SAT971J

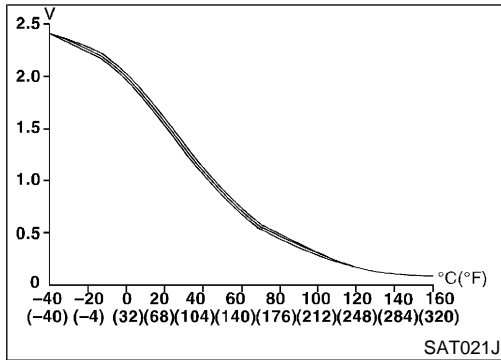

DIAGNOSTIC TROUBLE CODE (DTC) CONFIRMATION PROCEDURE

NDAT0049S03

CAUTION:

- Always drive vehicle at a safe speed.
- Be careful not to rev engine into the red zone on the tachometer.

NOTE:

If "DIAGNOSTIC TROUBLE CODE CONFIRMATION PROCEDURE" has been previously conducted, always turn ignition switch OFF and wait at least 5 seconds before conducting the next test.

TESTING CONDITION:

Always drive vehicle on a level road to improve the accuracy of test.

After the repair, perform the following procedure to confirm the malfunction is eliminated.

With CONSULT-II

- 1) Start engine and select "TCM INPUT SIGNALS" in "DATA MONITOR" mode for "A/T" with CONSULT-II.
- 2) Make sure that output voltage of A/T fluid temperature sensor is within the range below.

FLUID TEMP SEN: 0.4 - 1.5V

If out of range, drive the vehicle to decrease the voltage (warm up the fluid) or stop engine to increase the voltage (cool down the fluid).

- 3) Select "2ND GR FNCTN P0732" of "DTC WORK SUPPORT" mode for "A/T" with CONSULT-II and touch "START".
- 4) Accelerate vehicle to 57 to 62 km/h (35 to 39 MPH) under the following condition and release the accelerator pedal completely.

THROTTLE POSI: Less than 1.0/8

Selector lever: D position (O/D ON)

- Check that "GEAR" shows "3" or "4" after releasing pedal.
- 5) Depress accelerator pedal to WOT (more than 7.0/8 of "THROTTLE POSI") quickly from a speed of 57 to 62 km/h (35 to 39 MPH) until "TESTING" changes to "STOP VEHICLE" or "COMPLETE". (It will take approximately 3 seconds.)
If the check result NG appears on CONSULT-II screen, go to "DIAGNOSTIC PROCEDURE", AT-137.
If "STOP VEHICLE" appears on CONSULT-II screen, go to following step.

- Check that "GEAR" shows "2" when depressing accelerator pedal to WOT.
- If "TESTING" does not appear on CONSULT-II for a long time, select "SELF-DIAGNOSIS" for "ENGINE". In case a 1st trip DTC other than P0732 is shown, refer to applicable "TROUBLE DIAGNOSIS FOR DTC".

- 6) Stop vehicle.
- 7) Follow the instruction displayed. (Check for normal shifting referring to the table below.)

Vehicle condition	Gear on actual transmission shift pattern when screen is changed to 1 → 2 → 3 → 4
No malfunction exists	1 → 2 → 3 → 4
Malfunction for P0732 exists.	4 → 3 → 3 → 4

- 8) Make sure that "OK" is displayed. (If "NG" is displayed, refer to "DIAGNOSTIC PROCEDURE".)

DTC P0732 A/T 2ND GEAR FUNCTION

Description (Cont'd)

Refer to "DIAGNOSTIC PROCEDURE", AT-137.
Refer to "Shift Schedule", AT-370.



With GST

Follow procedure "With CONSULT-II".

GI

MA

EM

LC

EC

FE

AT

AX

SU

BR

ST

RS

BT

HA

SC

EL

IDX

DTC P0732 A/T 2ND GEAR FUNCTION

Wiring Diagram — AT — 2ND

Wiring Diagram — AT — 2ND

NDAT0202

AT-2NDSIG-01

— : Detectable line for DTC
— : Non-detectable line for DTC

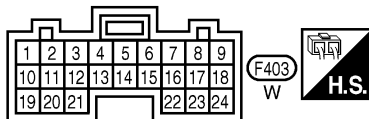
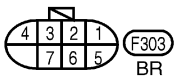
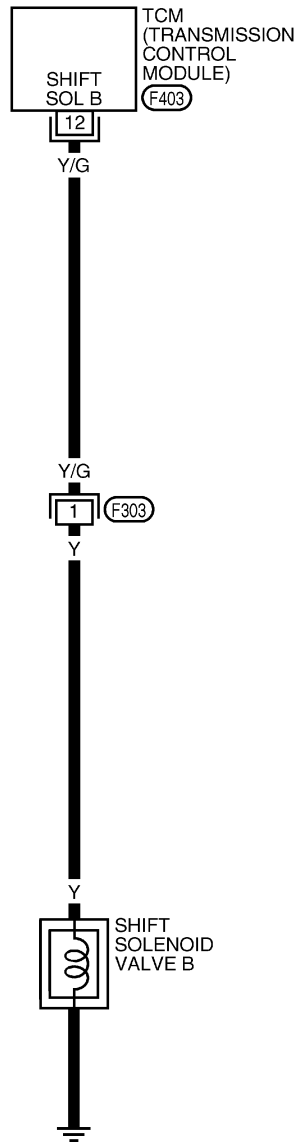

AAT279A

DTC P0732 A/T 2ND GEAR FUNCTION

Diagnostic Procedure

Diagnostic Procedure

NDAT0050

1	CHECK SHIFT SOLENOID VALVE	
<p>1. Remove control valve assembly. Refer to AT-270. 2. Check shift solenoid valve operation.</p> <ul style="list-style-type: none"> ● Shift solenoid valve B Refer to "Component Inspection", AT-138. <p style="text-align: center;">OK or NG</p>		
OK	▶	GO TO 2.
NG	▶	Repair or replace shift solenoid valve assembly.

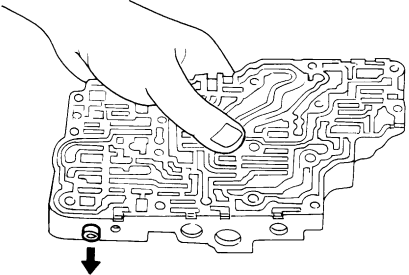
2	CHECK CONTROL VALVE	
<p>1. Disassemble control valve assembly. Refer to "Control Valve Assembly", AT-302. 2. Check to ensure that:</p> <ul style="list-style-type: none"> ● Valve, sleeve and plug slide along valve bore under their own weight. ● Valve, sleeve and plug are free from burrs, dents and scratches. ● Control valve springs are free from damage, deformation and fatigue. ● Hydraulic line is free from obstacles. <div style="text-align: center;">  </div> <p style="text-align: right;">SAT367H</p> <p style="text-align: center;">OK or NG</p>		
OK	▶	GO TO 3.
NG	▶	Repair control valve assembly.

3	CHECK DTC	
<p>Perform "DIAGNOSTIC TROUBLE CODE (DTC) CONFIRMATION PROCEDURE", AT-134.</p> <p style="text-align: center;">OK or NG</p>		
OK	▶	INSPECTION END
NG	▶	Check control valve again. Repair or replace control valve assembly.

GI

MA

EM

LC

EC

FE

AT

AX

SU

BR

ST

RS

BT

HA

SC

EL

IDX

DTC P0732 A/T 2ND GEAR FUNCTION

Component Inspection

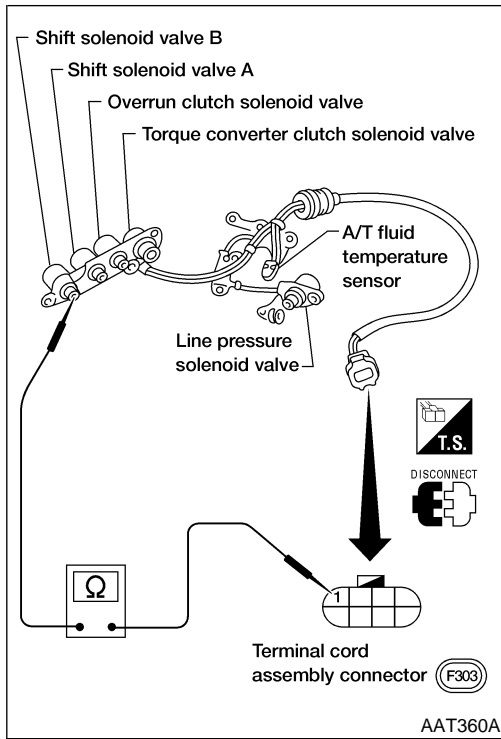

Component Inspection SHIFT SOLENOID VALVE B

=NDAT0051

NDAT0051S01

- For removal, refer to "Control Valve Assembly and Accumulators", AT-270.

Resistance Check

NDAT0051S0101

- Check resistance between two terminals.

Solenoid valve	Terminal No.		Resistance (Approx.)
	1	Ground	
Shift solenoid valve B	1	Ground	20 - 40Ω

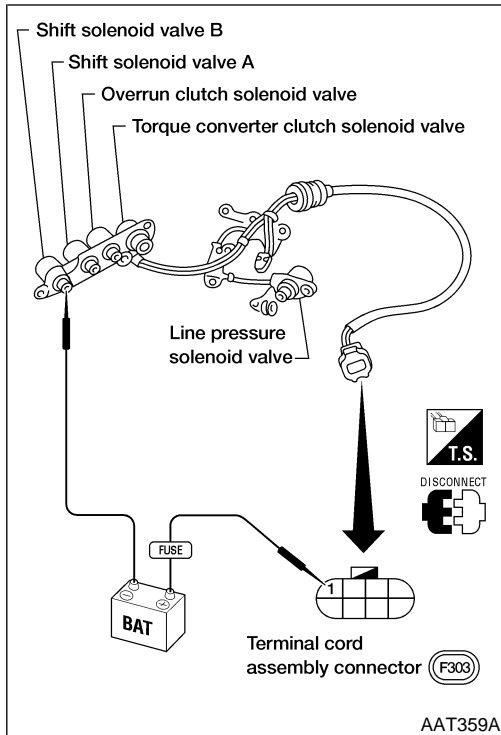

Operation Check

NDAT0051S0102

- Check solenoid valve by listening for its operating sound while applying battery voltage to the terminal and ground.

DTC P0733 A/T 3RD GEAR FUNCTION

Description

Description

- This is an OBD-II self-diagnostic item and not available in TCM self-diagnosis. NDAT0052
- This malfunction will not be detected while the O/D OFF indicator lamp is indicating another self-diagnosis malfunction. GI
- This malfunction is detected when the A/T does not shift into third gear position as instructed by the TCM. This is not caused by electrical malfunction (circuits open or shorted) but by mechanical malfunction such as control valve sticking, improper solenoid valve operation, malfunctioning servo piston or brake band, etc. MA

Gear position	1	2	3	4
Shift solenoid valve A	ON (Closed)	OFF (Open)	OFF (Open)	ON (Closed)
Shift solenoid valve B	ON (Closed)	ON (Closed)	OFF (Open)	OFF (Open)

TCM TERMINALS AND REFERENCE VALUE

NDAT0052S01

Remarks: Specification data are reference values.

Terminal No.	Wire color	Item	Condition	Judgement standard (Approx.)
11	Y/PU	Shift solenoid valve A	 When shift solenoid valve A operates. (When driving in D ₁ or D ₄ .)	Battery voltage
			When shift solenoid valve A does not operate. (When driving in D ₂ or D ₃ .)	0V

ON BOARD DIAGNOSTIC LOGIC

NDAT0052S02

This diagnosis monitors actual gear position by checking the torque converter slip ratio calculated by TCM as follows:

Torque converter slip ratio = A x C/B

A: Output shaft revolution signal from revolution sensor



B: Engine speed signal from ECM

C: Gear ratio determined as gear position which TCM supposes
If the actual gear position is higher than the position (3rd) supposed by TCM, the slip ratio will be more than normal. In case the ratio exceeds the specified value, TCM judges this diagnosis malfunction. ST

This malfunction will be caused when shift solenoid valve A is stuck closed. RS

Gear position supposed by TCM	1	2	3	4
In case of gear position with no malfunctions	1	2	3	4
In case of gear position with shift solenoid valve A stuck closed	1	1	4*	4

*: P0733 is detected. BT

Diagnostic trouble code	Malfunction is detected when ...	Check item (Possible cause)
 : A/T 3RD GR FNCTN	A/T cannot be shifted to the 3rd gear position even if electrical circuit is good. <small>HA</small>	<ul style="list-style-type: none"> • Shift solenoid valve A • Each clutch • Hydraulic control circuit
 : P0733		
 : MIL Code No. 1105 <small>SC</small>		

DTC P0733 A/T 3RD GEAR FUNCTION

Description (Cont'd)

SELECT SYSTEM
A/T
ENGINE

SAT014K

SELECT DIAG MODE
SELF-DIAG RESULTS
DATA MONITOR
DTC WORK SUPPORT
TCM PART NUMBER

SAT971J

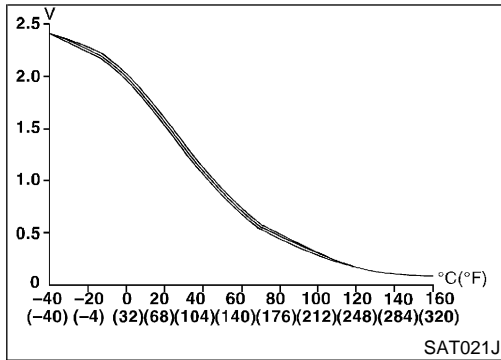

DIAGNOSTIC TROUBLE CODE (DTC) CONFIRMATION PROCEDURE

NDAT0052S03

CAUTION:

- Always drive vehicle at a safe speed.
- Be careful not to rev engine into the red zone on the tachometer.

NOTE:

If "DIAGNOSTIC TROUBLE CODE CONFIRMATION PROCEDURE" has been previously conducted, always turn ignition switch "OFF" and wait at least 5 seconds before conducting the next test.

TESTING CONDITION:

Always drive vehicle on a level road to improve the accuracy of test.

After the repair, perform the following procedure to confirm the malfunction is eliminated.

With CONSULT-II

- 1) Start engine and select "TCM INPUT SIGNALS" in "DATA MONITOR" mode for "A/T" with CONSULT-II.
- 2) Make sure that output voltage of A/T fluid temperature sensor is within the range below.

FLUID TEMP SEN: 0.4 - 1.5V

If out of range, drive the vehicle to decrease the voltage (warm up the fluid) or stop engine to increase the voltage (cool down the fluid).

- 3) Select "3RD GR FNCTN P0733" of "DTC WORK SUPPORT" mode for "A/T" with CONSULT-II and touch "START".
- 4) Accelerate vehicle to 70 to 85 km/h (43 to 53 MPH) under the following condition and release the accelerator pedal completely.

THROTTLE POSI: Less than 1.0/8 (at all times during step 4)

Selector lever: D position (OD "ON")

- Check that "GEAR" shows "4" after releasing pedal.
- 5) Depress accelerator pedal steadily with 3.5/8 - 4.5/8 of "THROTTLE POSI" from a speed of 70 to 85 km/h (43 to 53 MPH) until "TESTING" changes to "STOP VEHICLE" or "COMPLETED". (It will take approximately 3 seconds.)
If the check result NG appears on CONSULT-II screen, go to "DIAGNOSTIC PROCEDURE", AT-143.
If "STOP VEHICLE" appears on CONSULT-II screen, go to following step.
 - Check that "GEAR" shows "3" when depressing accelerator pedal with 3.5/8 - 4.5/8 of "THROTTLE POSI".
 - If "TESTING" does not appear on CONSULT-II for a long time, select "SELF-DIAGNOSIS" for "ENGINE". In case a 1st trip DTC other than P0733 is shown, refer to applicable "TROUBLE DIAGNOSIS FOR DTC".
 - 6) Stop vehicle.
 - 7) Follow the instruction displayed. (Check for normal shifting referring to the table below.)

Vehicle condition	Gear on actual transmission shift pattern when screen is changed to 1 → 2 → 3 → 4
No malfunction exists.	1 → 2 → 3 → 4
Malfunction for P0733 exists.	1 → 1 → 4 → 4

- 8) Make sure that "OK" is displayed. (If "NG" is displayed, refer

DTC P0733 A/T 3RD GEAR FUNCTION

Description (Cont'd)

to "DIAGNOSTIC PROCEDURE".)
Refer to "DIAGNOSTIC PROCEDURE", AT-143.
Refer to "Shift Schedule", AT-370.

 **With GST**

Follow the procedure "With CONSULT-II".

GI

MA

EM

LC

EC

FE

AT

AX

SU

BR

ST

RS

BT

HA

SC

EL

IDX

DTC P0733 A/T 3RD GEAR FUNCTION

Wiring Diagram — AT — 3RD

Wiring Diagram — AT — 3RD

NDAT0203

AT-3RDSIG-01

— : Detectable line for DTC
— : Non-detectable line for DTC

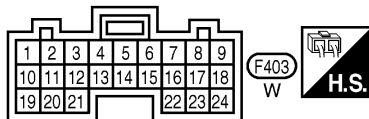
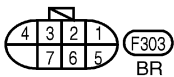
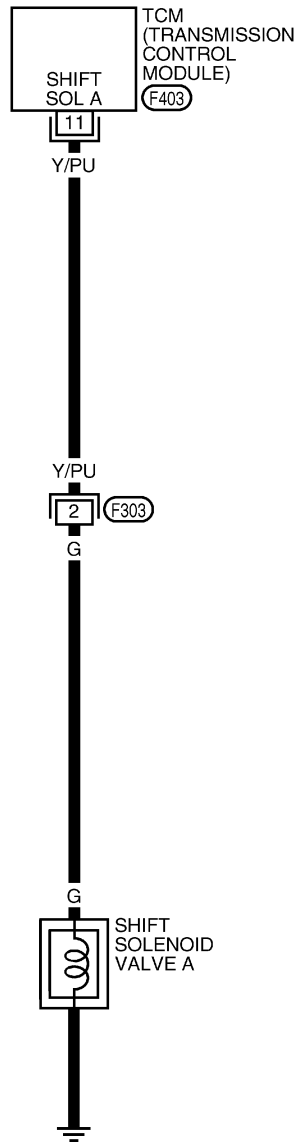

AAT280A

DTC P0733 A/T 3RD GEAR FUNCTION

Diagnostic Procedure

Diagnostic Procedure

NDAT0053

1	CHECK SHIFT SOLENOID VALVE	
<p>1. Remove control valve assembly. Refer to "Control Valve Assembly and Accumulators", AT-270.</p> <p>2. Check shift solenoid valve operation.</p> <ul style="list-style-type: none"> ● Shift solenoid valve A Refer to "Component Inspection", AT-144. <p style="text-align: center;">OK or NG</p>		
OK	▶	GO TO 2.
NG	▶	Repair or replace shift solenoid valve assembly.

GI
MA
EM
LC

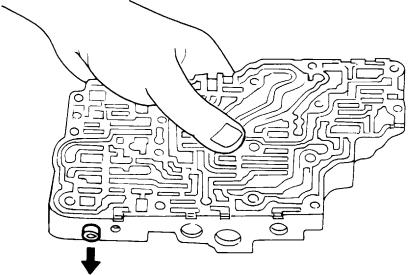
2	CHECK CONTROL VALVE	
<p>1. Disassemble control valve assembly. Refer to "Control Valve Assembly", AT-302.</p> <p>2. Check to ensure that:</p> <ul style="list-style-type: none"> ● Valve, sleeve and plug slide along valve bore under their own weight. ● Valve, sleeve and plug are free from burrs, dents and scratches. ● Control valve springs are free from damage, deformation and fatigue. ● Hydraulic line is free from obstacles. <div style="text-align: center;">  </div> <p style="text-align: right;">SAT367H</p> <p style="text-align: center;">OK or NG</p>		
OK	▶	GO TO 3.
NG	▶	Repair control valve assembly.

EC
FE

AT

AX
SU
BR
ST

3	CHECK DTC	
<p>Perform "DIAGNOSTIC TROUBLE CODE (DTC) CONFIRMATION PROCEDURE", AT-140.</p> <p style="text-align: center;">OK or NG</p>		
OK	▶	INSPECTION END
NG	▶	Check control valve again. Repair or replace control valve assembly.

RS
BT

HA
SC

EL
IDX

DTC P0733 A/T 3RD GEAR FUNCTION

Component Inspection

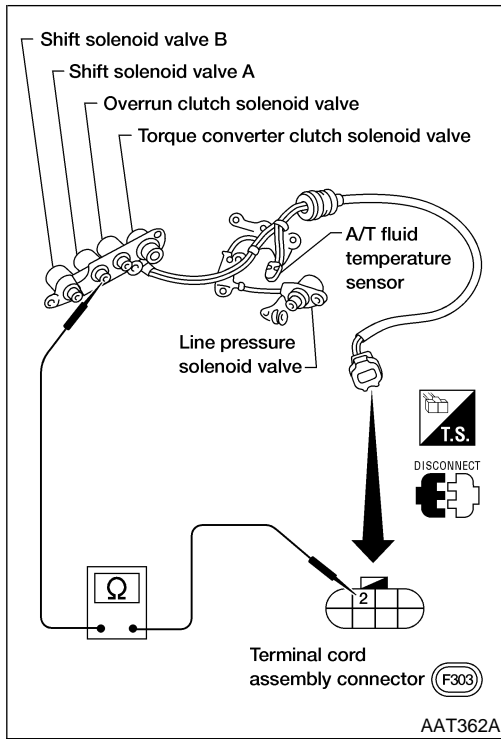

Component Inspection SHIFT SOLENOID VALVE A

=NDAT0054

NDAT0054S01

- For removal, refer to "Control Valve Assembly and Accumulators", AT-270.

Resistance Check

NDAT0054S0101

- Check resistance between two terminals.

Solenoid valve	Terminal No.		Resistance (Approx.)
	1	2	
Shift solenoid valve A	2	Ground	20 - 40Ω

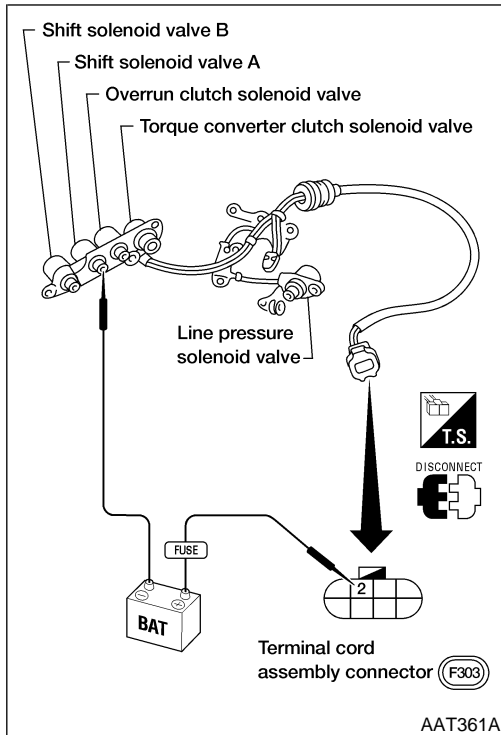

Operation Check

NDAT0054S0102

- Check solenoid valve by listening for its operating sound while applying battery voltage to the terminal and ground.

DTC P0734 A/T 4TH GEAR FUNCTION

Description

Description

- This is an OBD-II self-diagnostic item and not available in TCM self-diagnosis. NDAT0055
- This malfunction will not be detected while the O/D OFF indicator lamp is indicating another self-diagnosis malfunction.
- This malfunction is detected when the A/T does not shift into fourth gear position or the torque converter clutch does not lock up as instructed by the TCM. This is not caused by electrical malfunction (circuits open or shorted) but by mechanical malfunction such as control valve sticking, improper solenoid valve operation, malfunctioning oil pump or torque converter clutch, etc.

Gear position	1	2	3	4
Shift solenoid valve A	ON (Closed)	OFF (Open)	OFF (Open)	ON (Closed)
Shift solenoid valve B	ON (Closed)	ON (Closed)	OFF (Open)	OFF (Open)

CONSULT-II REFERENCE VALUE IN DATA MONITOR MODE

NDAT0055S01



Remarks: Specification data are reference values.

Monitor item	Condition	Specification (Approx.)
Torque converter clutch solenoid valve duty	Lock-up OFF	4%
	↓ Lock-up ON	94%
Line pressure solenoid valve duty	Small throttle opening (Low line pressure)	24%
	↓ Large throttle opening (High line pressure)	95%

TCM TERMINALS AND REFERENCE VALUE

NDAT0055S02

Remarks: Specification data are reference values.

Terminal No.	Wire color	Item	Condition	Judgement standard (Approx.)	
1	G/R	Line pressure solenoid valve		When releasing accelerator pedal after warming up engine.	1.5 - 2.5V
				When depressing accelerator pedal fully after warming up engine.	0V
2	Y/B	Line pressure solenoid valve (with dropping resistor)		When releasing accelerator pedal after warming up engine.	4 - 14V
				When depressing accelerator pedal fully after warming up engine.	0V

DTC P0734 A/T 4TH GEAR FUNCTION

Description (Cont'd)

Terminal No.	Wire color	Item	Condition		Judgement standard (Approx.)
11	Y/PU	Shift solenoid valve A		When shift solenoid valve A operates. (When driving in D ₁ or D ₄ .)	Battery voltage
				When shift solenoid valve A does not operate. (When driving in D ₂ or D ₃ .)	0V
12	Y/G	Shift solenoid valve B		When shift solenoid valve B operates. (When driving in D ₁ or D ₂ .)	Battery voltage
				When shift solenoid valve B does not operate. (When driving in D ₃ or D ₄ .)	0V

ON BOARD DIAGNOSTIC LOGIC

NDAT0055S03

This diagnosis monitors actual gear position by checking the torque converter slip ratio calculated by TCM as follows:

Torque converter slip ratio = A x C/B

A: Output shaft revolution signal from revolution sensor

B: Engine speed signal from ECM



C: Gear ratio determined as gear position which TCM supposes

If the actual gear position is much lower than the position (4th) supposed by TCM, the slip ratio will be much less than normal. In case the ratio does not reach the specified value, TCM judges this diagnosis malfunction.

This malfunction will be caused when shift solenoid valve B is stuck closed.

Gear position supposed by TCM	1	2	3	4
In case of gear position with no malfunctions	1	2	3	4
In case of gear position with shift solenoid valve B stuck closed	1	2	2	1*

*: P0734 is detected.

Diagnostic trouble code	Malfunction is detected when ...	Check items (Possible cause)
 : A/T 4TH GR FNCTN	A/T cannot be shifted to the 4th gear position even if electrical circuit is good.	<ul style="list-style-type: none"> ● Shift solenoid valve A ● Shift solenoid valve B ● Overrun clutch solenoid valve ● Line pressure solenoid valve ● Each clutch ● Hydraulic control circuit ● Torque converter clutch solenoid valve
 : P0734		
 : MIL Code No. 1106		

DTC P0734 A/T 4TH GEAR FUNCTION

Description (Cont'd)

SELECT SYSTEM
A/T
ENGINE

SAT014K

SELECT DIAG MODE
SELF-DIAG RESULTS
DATA MONITOR
DTC WORK SUPPORT
TCM PART NUMBER

SAT971J

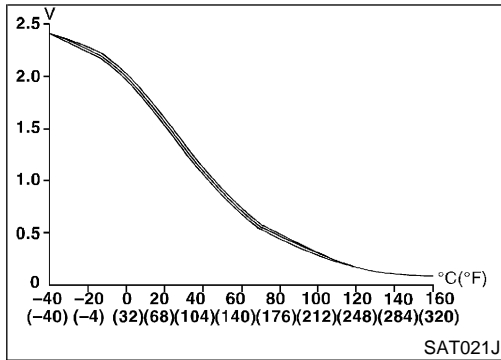

DIAGNOSTIC TROUBLE CODE (DTC) CONFIRMATION PROCEDURE

NDAT0055S04

CAUTION:

- Always drive vehicle at a safe speed.
- If conducting this “DTC CONFIRMATION PROCEDURE” again, always turn ignition switch OFF and wait at least 5 seconds before continuing.
- Be careful not to rev engine into the red zone on the tachometer.

NOTE:

If “DIAGNOSTIC TROUBLE CODE CONFIRMATION PROCEDURE” has been previously conducted, always turn ignition switch OFF and wait at least 5 seconds before conducting the next test.

TESTING CONDITION:

Always drive vehicle on a level road to improve the accuracy of test.

After the repair, perform the following procedure to confirm the malfunction is eliminated.

With CONSULT-II

- 1) Start engine and select “TCM INPUT SIGNAL” in “DATA MONITOR” mode for “A/T” with CONSULT-II.
- 2) Make sure that output voltage of A/T fluid temperature sensor is within the range below.

FLUID TEMP SEN: 0.4 - 1.5V

If out of range, drive the vehicle to decrease the voltage (warm up the fluid) or stop engine to increase the voltage (cool down the fluid).

- 3) Select “4TH GR FNCTN P0734” of “DTC WORK SUPPORT” mode for “A/T” with CONSULT-II and touch “START”.
- 4) Accelerate vehicle to 42 to 52 km/h (26 to 32 MPH) under the following condition and release the accelerator pedal completely.

THROTTLE POSI: Less than 5.5/8 (at all times during step 4)

Selector lever: D position (O/D ON)

- Check that “GEAR” shows “3” after releasing pedal.
- 5) Depress accelerator pedal steadily with 1.0/8 - 2.0/8 of “THROTTLE POSI” from a speed of 42 to 52 km/h (26 to 32 MPH) until “TESTING” has turned to “STOP VEHICLE” or “COMPLETED”. (It will take approximately 3 seconds.)
If the check result NG appears on CONSULT-II screen, go to “DIAGNOSTIC PROCEDURE”, AT-150.
If “STOP VEHICLE” appears on CONSULT-II screen, go to following step.
 - Check that “GEAR” shows “4” when depressing accelerator pedal with 1.0/8 - 2.0/8 of “THROTTLE POSI”.
 - If “TESTING” does not appear on CONSULT-II for a long time, select “SELF-DIAGNOSIS” for “ENGINE”. In case a 1st trip DTC other than P0734 is shown, refer to applicable “TROUBLE DIAGNOSIS FOR DTC”.
 - 6) Stop vehicle.
 - 7) Follow the instruction displayed. (Check for normal shifting referring to the table below.)

Vehicle condition	Gear on actual transmission shift pattern when screen is changed to 1 → 2 → 3 → 4
No malfunction exists	1 → 2 → 3 → 4

GI

MA

EM

LC

EC

FE

AT

AX

SU

BR

ST

RS

BT

HA

SC

EL

IDX

DTC P0734 A/T 4TH GEAR FUNCTION

Description (Cont'd)

Vehicle condition	Gear on actual transmission shift pattern when screen is changed to 1 → 2 → 3 → 4
Malfunction for P0734 exists.	1 → 2 → 2 → 1

- 8) Make sure that "OK" is displayed. (If "NG" is displayed, refer to "DIAGNOSTIC PROCEDURE".)
Refer to "DIAGNOSTIC PROCEDURE", AT-150.
Refer to "Shift Schedule", AT-370.

 **With GST**

Follow the procedure "With CONSULT-II".

DTC P0734 A/T 4TH GEAR FUNCTION

Wiring Diagram — AT — 4TH

Wiring Diagram — AT — 4TH

NDAT0204

AT-4THSIG-01

GI

MA

EM

LC

EC

FE

AT

AX

SU

BR

ST

RS

BT

HA

SC

EL

IDX

— : Detectable line for DTC

- - - : Non-detectable line for DTC

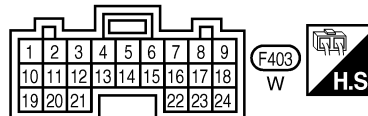
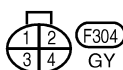
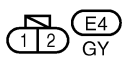
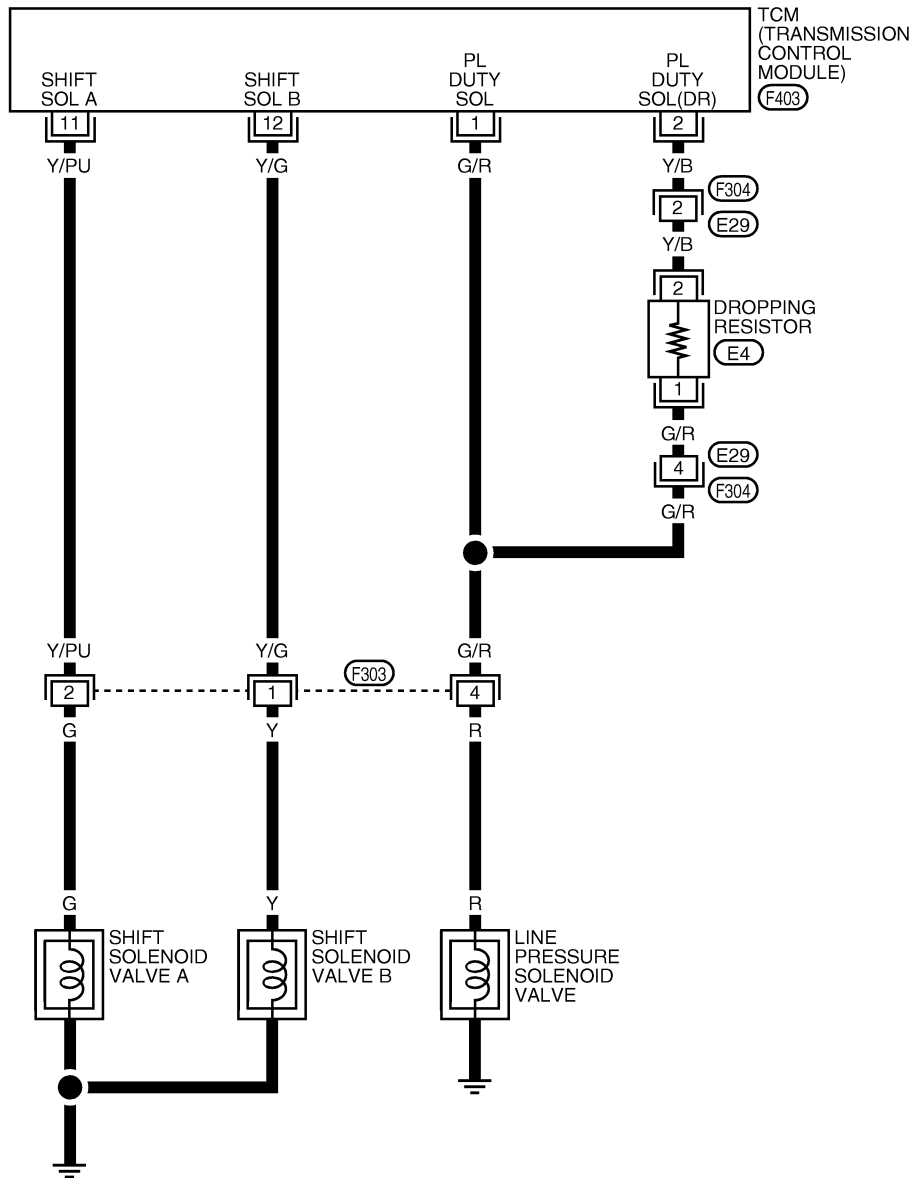

DTC P0734 A/T 4TH GEAR FUNCTION

Diagnostic Procedure

Diagnostic Procedure

NDAT0056

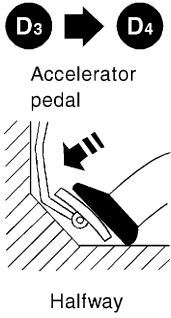
1	CHECK SHIFT UP (D₃ TO D₄)		
<p>During "Cruise test – Part 1" (AT-74), does A/T shift from D₃ to D₄ at the specified speed?</p> <div style="text-align: center;">  <p>Accelerator pedal</p> <p>Halfway</p> </div> <p style="text-align: right;">SAT988H</p>			
Yes or No			
Yes	▶	GO TO 9.	
No	▶	GO TO 2.	

2	CHECK LINE PRESSURE		
<p>Perform line pressure test. Refer to "Line Pressure Test", AT-65.</p> <p style="text-align: center;">OK or NG</p>			
OK	▶	GO TO 3.	
NG	▶	GO TO 6.	

3	CHECK SOLENOID VALVES		
<p>1. Remove control valve assembly. Refer to "Control Valve Assembly and Accumulators", AT-270.</p> <p>2. Refer to "Component Inspection", AT-153.</p> <p style="text-align: center;">OK or NG</p>			
OK	▶	GO TO 4.	
NG	▶	Replace solenoid valve assembly.	

DTC P0734 A/T 4TH GEAR FUNCTION

Diagnostic Procedure (Cont'd)

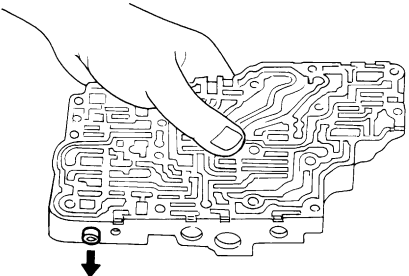
4	CHECK CONTROL VALVE	<p>1. Disassemble control valve assembly. Refer to "Control Valve Assembly", AT-302.</p> <p>2. Check to ensure that:</p> <ul style="list-style-type: none"> ● Valve, sleeve and plug slide along valve bore under their own weight. ● Valve, sleeve and plug are free from burrs, dents and scratches. ● Control valve springs are free from damage, deformation and fatigue. ● Hydraulic line is free from obstacles. 	GI
			MA
		OK or NG	EM
		SAT367H	LC
			EC
			FE
			AT
OK	▶	GO TO 5.	AX
NG	▶	Repair control valve.	SU

5	CHECK SHIFT UP (D₃ TO D₄)	<p>Does A/T shift from D₃ to D₄ at the specified speed?</p>	
		OK or NG	BR
OK	▶	GO TO 9.	ST
NG	▶	Check control valve again. Repair or replace control valve assembly.	RS

6	CHECK LINE PRESSURE SOLENOID VALVE	<p>1. Remove control valve assembly. Refer to "Control Valve Assembly and Accumulators", AT-270.</p> <p>2. Refer to "Component Inspection", AT-302.</p>	
		OK or NG	BT
OK	▶	GO TO 7.	HA
NG	▶	Replace solenoid valve assembly.	SC

GI
MA
EM
LC
EC
FE
AT
AX
SU
BR
ST
RS
BT
HA
SC
EL
IDX

DTC P0734 A/T 4TH GEAR FUNCTION

Diagnostic Procedure (Cont'd)

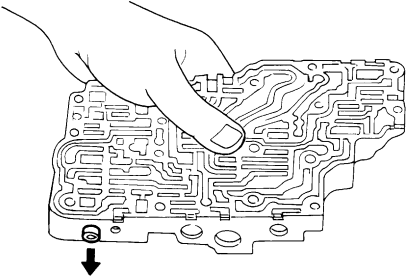
7	CHECK CONTROL VALVE	
<p>1. Disassemble control valve assembly. Refer to "Control Valve Assembly", AT-302.</p> <p>2. Check line pressure circuit valves for sticking.</p> <ul style="list-style-type: none"> ● Pressure regulator valve ● Pilot valve ● Pressure modifier valve 		
		
SAT367H		
OK or NG		
OK	▶	GO TO 8.
NG	▶	Repair control valve.

8	CHECK SHIFT UP (D₃ TO D₄)	
Does A/T shift from D ₃ to D ₄ at the specified speed?		
OK or NG		
OK	▶	GO TO 9.
NG	▶	Check control valve again. Repair or replace control valve assembly.

9	CHECK DTC	
Perform "DIAGNOSTIC TROUBLE CODE (DTC) CONFIRMATION PROCEDURE", AT-147.		
OK or NG		
OK	▶	INSPECTION END
NG	▶	Perform "Cruise Test—Part 1" again and return to the start point of this flow chart.

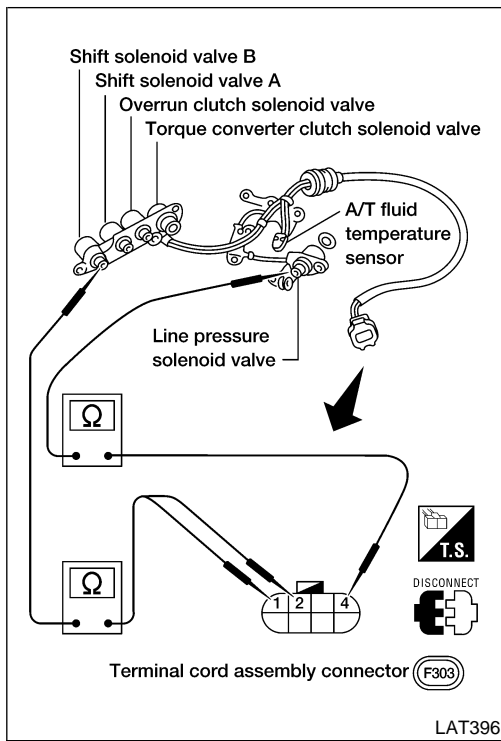

Component Inspection

=NDAT0057

SOLENOID VALVES

NDAT0057S01

- For removal, refer to "Control Valve Assembly and Accumulators", AT-270.

Resistance Check

NDAT0057S0101

- Check resistance between two terminals.

Solenoid valve	Terminal No.		Resistance (Approx.)
Shift solenoid valve A	2	Ground	20 - 40Ω
Shift solenoid valve B	1		
Line pressure solenoid valve	4		2.5 - 5Ω

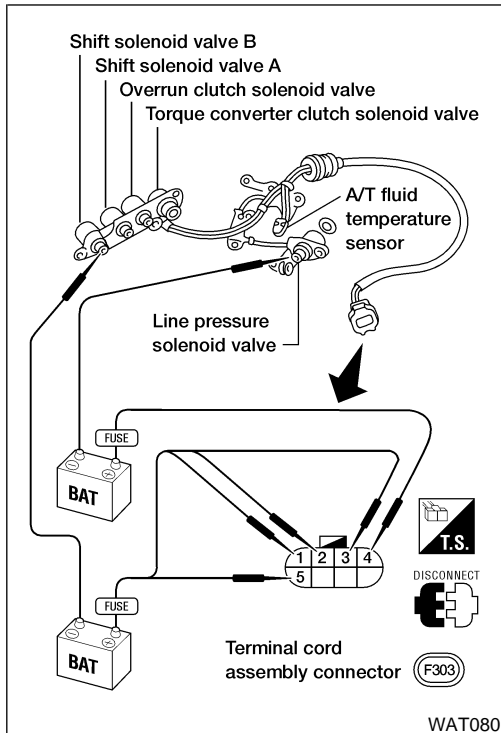

Operation Check

NDAT0057S0102

- Check solenoid valve by listening for its operating sound while applying battery voltage to the terminal and ground.

DTC P0740 TORQUE CONVERTER CLUTCH SOLENOID VALVE

Description

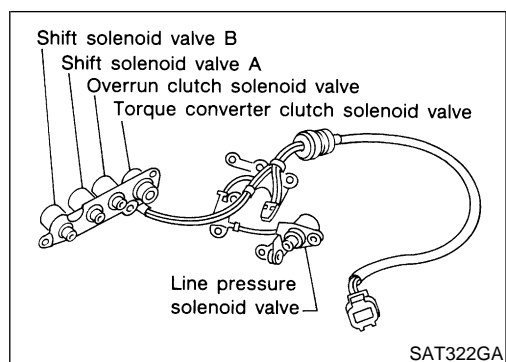

Description

The torque converter clutch solenoid valve is activated, with the gear in D₄, by the TCM in response to signals sent from the vehicle speed and throttle position sensors. Lock-up piston operation will then be controlled.

Lock-up operation, however, is prohibited when A/T fluid temperature is too low.

When the accelerator pedal is depressed (less than 2/8) in lock-up condition, the engine speed should not change abruptly. If there is a big jump in engine speed, there is no lock-up.

CONSULT-II REFERENCE VALUE IN DATA MONITOR MODE

NDAT0058S01

Remarks: Specification data are reference values.

Monitor item	Condition	Specification (Approx.)
Torque converter clutch solenoid valve duty	Lock-up OFF	4%
	↓ Lock-up ON	↓ 94%

TCM TERMINALS AND REFERENCE VALUE

NDAT0058S02

Remarks: Specification data are reference values.

Terminal No.	Wire color	Item	Condition	Judgement standard (Approx.)
3	OR/L	Torque converter clutch solenoid valve	 When A/T performs lock-up.	8 - 15V
			When A/T does not perform lock-up.	0V

ON BOARD DIAGNOSIS LOGIC

NDAT0058S03

Diagnostic trouble code	Malfunction is detected when ...	Check items (Possible cause)
P : TCC SOLENOID/CIRC GST : P0740 NO TOOLS : MIL Code No. 1204	TCM detects an improper voltage drop when it tries to operate the solenoid valve.	<ul style="list-style-type: none"> • Harness or connectors (The solenoid circuit is open or shorted.) • T/C clutch solenoid valve

DTC P0740 TORQUE CONVERTER CLUTCH SOLENOID VALVE

Description (Cont'd)

SELECT SYSTEM
A/T
ENGINE

SAT014K

SELECT DIAG MODE
WORK SUPPORT
SELF-DIAG RESULTS
DATA MONITOR
DATA MONITOR (SPEC)
ACTIVE TEST
DTC & SRT CONFIRMATION

SEF949Y

DIAGNOSTIC TROUBLE CODE (DTC) CONFIRMATION PROCEDURE

NDAT0058S04

NOTE:

If "DIAGNOSTIC TROUBLE CODE CONFIRMATION PROCEDURE" has been previously conducted, always turn ignition switch OFF and wait at least 5 seconds before conducting the next test.

After the repair, perform the following procedure to confirm the malfunction is eliminated.

With CONSULT-II

- 1) Turn ignition switch ON.
- 2) Select "DATA MONITOR" mode for "ENGINE" with CONSULT-II and wait at least 1 second.

With GST

Follow procedure "With CONSULT-II".

GI

MA

EM

LC

EC

FE

AT

AX

SU

BR

ST

RS

BT

HA

SC

EL

IDX

DTC P0740 TORQUE CONVERTER CLUTCH SOLENOID VALVE

Wiring Diagram — AT — TCV

Wiring Diagram — AT — TCV

NDAT0205

AT-TCV-01

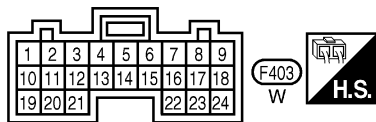
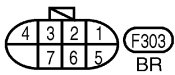
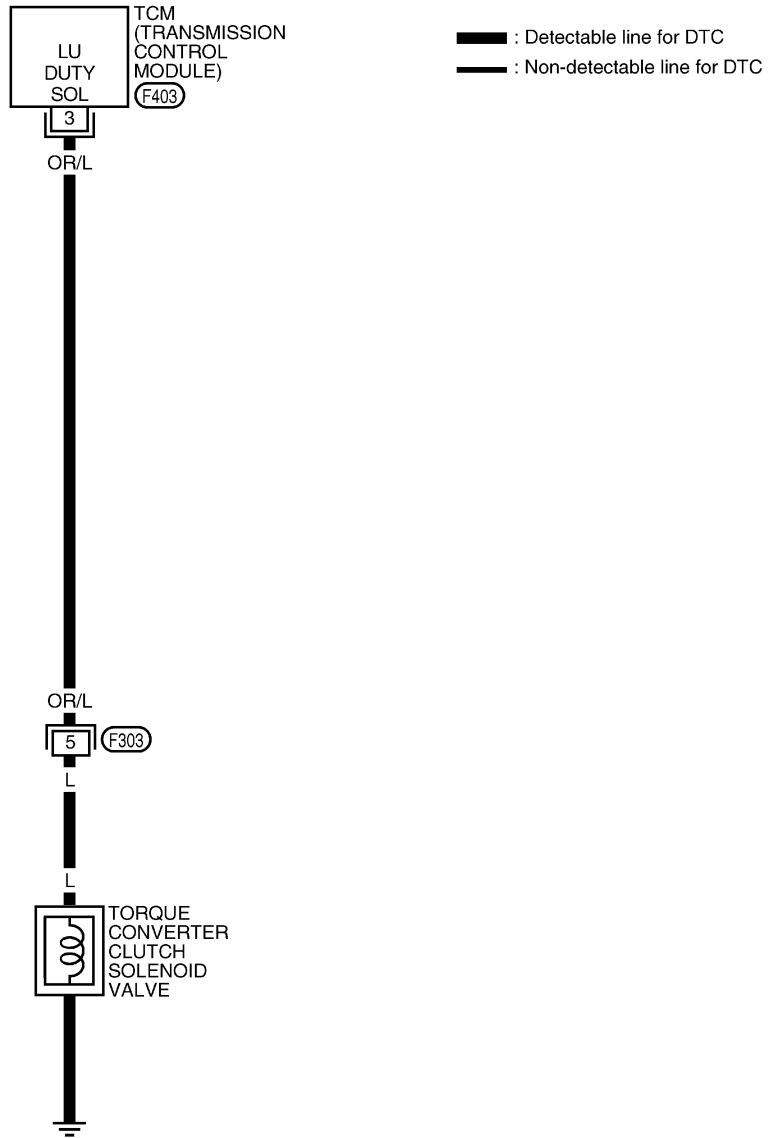

AAT269A

DTC P0740 TORQUE CONVERTER CLUTCH SOLENOID VALVE

Diagnostic Procedure

Diagnostic Procedure

NDAT0059

1	CHECK GROUND CIRCUIT	<p>1. Turn ignition switch to OFF position. 2. Disconnect terminal cord assembly connector in engine compartment. 3. Check resistance between terminal 5 and ground.</p> <div style="text-align: center;"> <p>Terminal cord assembly connector (F303)</p> </div> <p style="text-align: right;">AAT365A</p> <p>Resistance: 10 - 16Ω</p> <p style="text-align: center;">OK or NG</p>	<p>GI</p> <p>MA</p> <p>EM</p> <p>LC</p> <p>EC</p> <p>FE</p>
OK	▶	GO TO 2.	AT
NG	▶	<p>1. Remove oil pan. Refer to "Control Valve Assembly and Accumulators", AT-270. 2. Check the following items: <ul style="list-style-type: none"> ● Torque converter clutch solenoid valve Refer to "Component Inspection", AT-158. ● Harness of terminal cord assembly for short or open </p>	<p>AX</p> <p>SU</p>

2	CHECK POWER SOURCE CIRCUIT	<p>1. Turn ignition switch to OFF position. 2. Disconnect TCM harness connector. 3. Check continuity between terminal 5 and TCM harness connector terminal 3.</p> <div style="text-align: center;"> <p>Harness connector (F303) TCM connector (F403)</p> </div> <p style="text-align: right;">AAT366A</p> <p>Continuity should exist. If OK, check harness for short to ground and short to power.</p> <p>4. Reinstall any part removed.</p> <p style="text-align: center;">OK or NG</p>	<p>BR</p> <p>ST</p> <p>RS</p> <p>BT</p> <p>HA</p> <p>SC</p> <p>EL</p>
OK	▶	GO TO 3.	IDX
NG	▶	Repair open circuit or short to ground or short to power in harness or connectors.	

3	CHECK DTC	<p>Perform "DIAGNOSTIC TROUBLE CODE (DTC) CONFIRMATION PROCEDURE", AT-155.</p> <p style="text-align: center;">OK or NG</p>	
OK	▶	INSPECTION END	
NG	▶	<p>1. Perform TCM input/output signal inspection. 2. If NG, recheck TCM pin terminals for damage or loose connection with harness connector.</p>	

DTC P0740 TORQUE CONVERTER CLUTCH SOLENOID VALVE

Component Inspection

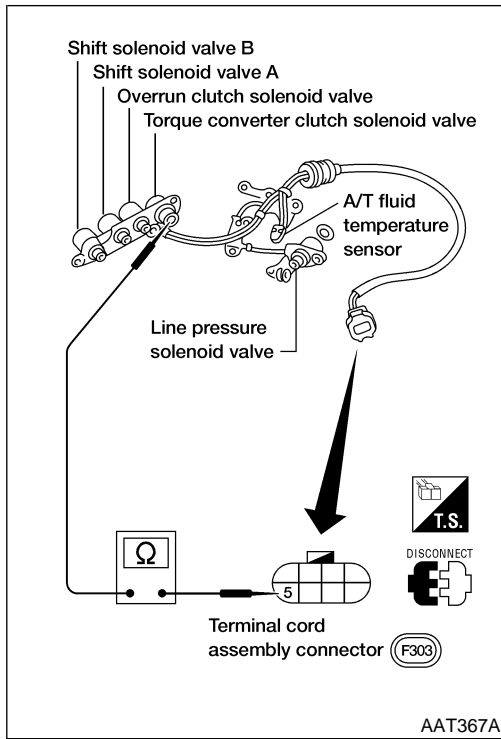

Component Inspection

TORQUE CONVERTER CLUTCH SOLENOID VALVE

=NDAT0060

NDAT0060S01

- For removal, refer to "Control Valve Assembly and Accumulators", AT-270.

Resistance Check

NDAT0060S0101

- Check resistance between two terminals.

Solenoid valve	Terminal No.		Resistance (Approx.)
	1	2	
Torque converter clutch solenoid valve	5	Ground	10 - 16Ω

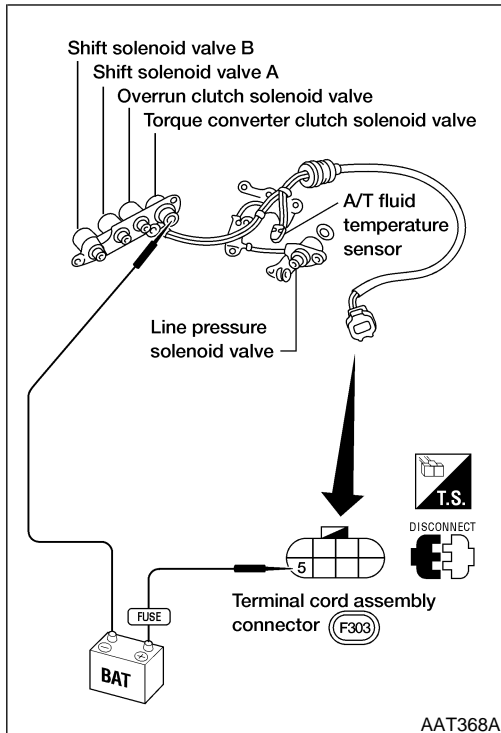

Operation Check

NDAT0060S0102

- Check solenoid valve by listening for its operating sound while applying battery voltage to the terminal and ground.

DTC P0744 A/T TCC S/V FUNCTION (LOCK-UP)

Description

Description

- This is an OBD-II self-diagnostic item and not available in TCM self-diagnosis. NDAT0061
- This malfunction will not be detected while the O/D OFF indicator lamp is indicating another self-diagnosis malfunction.
- This malfunction is detected when the A/T does not shift into fourth gear position or the torque converter clutch does not lock up as instructed by the TCM. This is not caused by electrical malfunction (circuits open or shorted) but by mechanical malfunction such as control valve sticking, improper solenoid valve operation, malfunctioning oil pump or torque converter clutch, etc.

CONSULT-II REFERENCE VALUE IN DATA MONITOR MODE

NDAT0061S01



Remarks: Specification data are reference values.

Monitor item	Condition	Specification (Approx.)
Torque converter clutch solenoid valve duty	Lock-up OFF	4%
	↓ Lock-up ON	↓ 94%

TCM TERMINALS AND REFERENCE VALUE

NDAT0061S02

Remarks: Specification data are reference values.

Terminal No.	Wire color	Item	Condition	Judgement standard (Approx.)	
1	G/R	Line pressure solenoid valve		When releasing accelerator pedal after warming up engine.	1.5 - 2.5V
				When depressing accelerator pedal fully after warming up engine.	0V
2	Y/B	Line pressure solenoid valve (with dropping resistor)		When releasing accelerator pedal after warming up engine.	4 - 14V
				When depressing accelerator pedal fully after warming up engine.	0V
3	OR/L	Torque converter clutch solenoid valve		When A/T performs lock-up.	8 - 15V
				When A/T does not perform lock-up.	0V

ON BOARD DIAGNOSTIC LOGIC

NDAT0061S03

This diagnosis monitors actual gear position by checking the torque converter slip ratio calculated by TCM as follows:

Torque converter slip ratio = A x C/B

A: Output shaft revolution signal from revolution sensor

B: Engine speed signal from ECM

C: Gear ratio determined as gear position which TCM supposes
If the actual gear position is much lower than the position (4th) supposed by TCM, the slip ratio will be much less than normal. In case the ratio does not reach the specified value, TCM judges this diagnosis malfunction.

This malfunction will be caused when shift solenoid valve B is stuck closed.

Gear position supposed by TCM	1	2	3	4
In case of gear position with no malfunctions	1	2	3	4

DTC P0744 A/T TCC S/V FUNCTION (LOCK-UP)

Description (Cont'd)

Gear position supposed by TCM	1	2	3	4
In case of gear position with shift solenoid valve B stuck closed	1	2	2	1*

*: P0744 is detected.

Diagnostic trouble code	Malfunction is detected when ...	Check items (Possible cause)
: A/T TCC S/V FNCTN	A/T cannot perform lock-up even if electrical circuit is good.	<ul style="list-style-type: none"> • Torque converter clutch solenoid valve • Each clutch • Hydraulic control circuit
: P0744		
: MIL Code No. 1107		

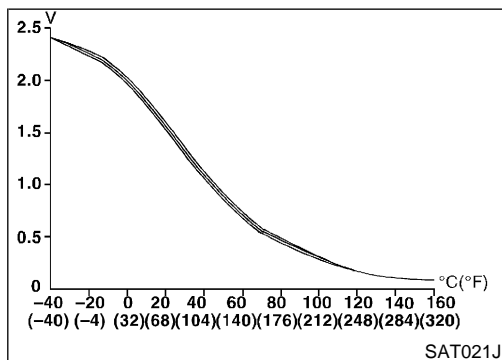
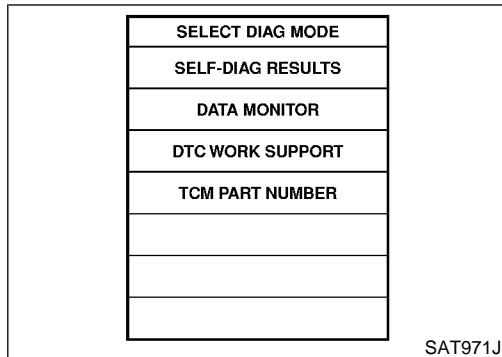
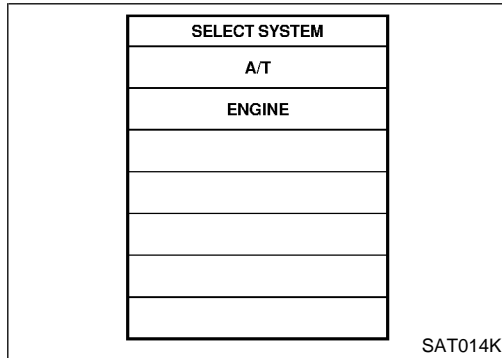

DIAGNOSTIC TROUBLE CODE (DTC) CONFIRMATION PROCEDURE

NDAT0061S04

CAUTION:

Always drive vehicle at a safe speed.

NOTE:

If "DIAGNOSTIC TROUBLE CODE CONFIRMATION PROCEDURE" has been previously conducted, always turn ignition switch OFF and wait at least 5 seconds before conducting the next test.

After the repair, perform the following procedure to confirm the malfunction is eliminated.

With CONSULT-II

1) Start engine and select "TCM INPUT SIGNALS" in "DATA MONITOR" mode for "A/T" with CONSULT-II.

2) Make sure that output voltage of A/T fluid temperature sensor is within the range below.

FLUID TEMP SEN: 0.4 - 1.5V

If out of range, drive vehicle to decrease voltage (warm up the fluid) or stop engine to increase voltage (cool down the fluid).

3) Select "TCC S/V FNCTN P0744" of "DTC WORK SUPPORT" mode for "A/T" with CONSULT-II and touch "START".

4) Accelerate vehicle to more than 80 km/h (50 MPH) and maintain the following condition continuously until "TESTING" has turned to "COMPLETE". (It will take approximately 30 seconds after "TESTING" shows.)

THROTTLE POSI: 1.0/8 - 2.0/8 (at all times during step 4)

Selector lever: D position (O/D ON)

TCC S/V DUTY: More than 94%

VHCL/S SE-A/T: Constant speed of more than 80 km/h (50 MPH)

- Check that "GEAR" shows "4".
- For shift schedule, refer to SDS, AT-370.
- If "TESTING" does not appear on CONSULT-II for a long time, select "SELF-DIAGNOSIS". In case a 1st trip DTC other than P0744 is shown, refer to applicable "TROUBLE DIAGNOSIS FOR DTC".

5) Make sure that "OK" is displayed. (If "NG" is displayed, refer to "DIAGNOSTIC PROCEDURE".)

Refer to "DIAGNOSTIC PROCEDURE", AT-162.

Refer to shift schedule, AT-370.

With GST

Follow procedure "With CONSULT-II".

DTC P0744 A/T TCC S/V FUNCTION (LOCK-UP)

Wiring Diagram — AT — TCCSIG

Wiring Diagram — AT — TCCSIG

NDAT0206

AT-TCCSIG-01

— : Detectable line for DTC
 - - - : Non-detectable line for DTC

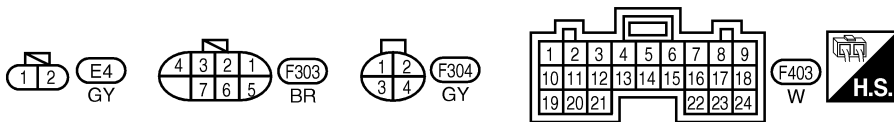
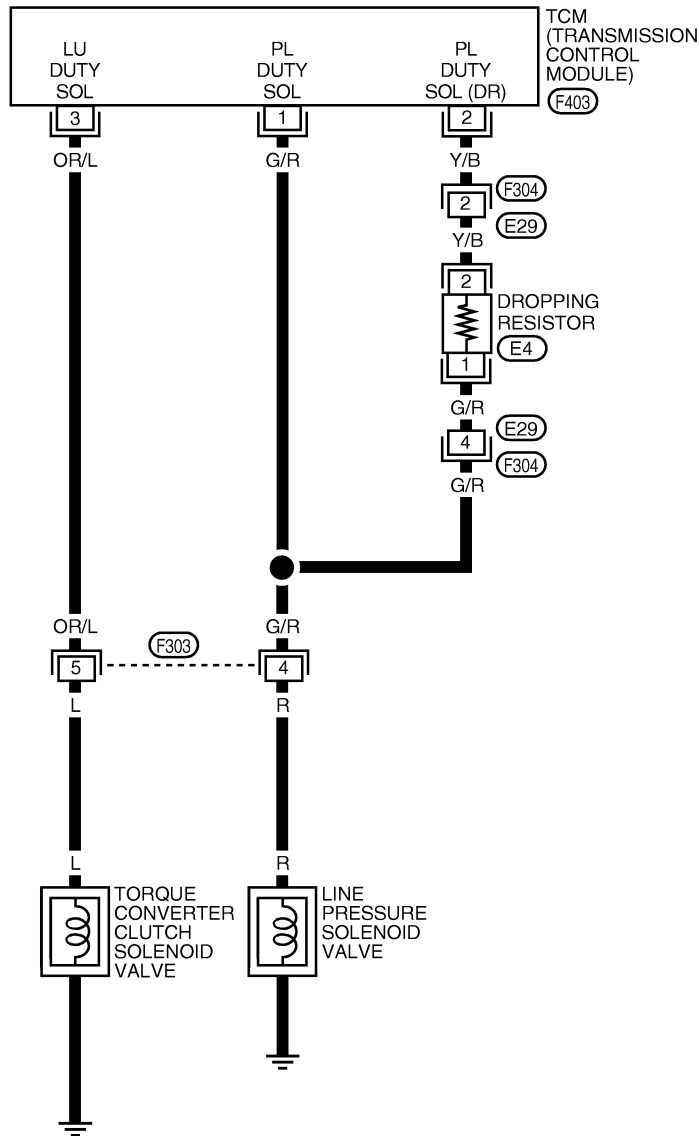

GI
 MA
 EM
 LC
 EC
 FE
AT
 AX
 SU
 BR
 ST
 RS
 BT
 HA
 SC
 EL
 IDX

DTC P0744 A/T TCC S/V FUNCTION (LOCK-UP)

Diagnostic Procedure

Diagnostic Procedure

NDAT0062

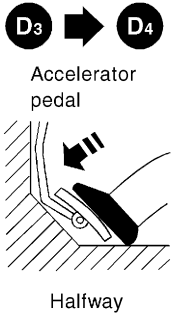
1	CHECK SHIFT UP (D₃ TO D₄)		
During "Cruise test – Part 1" (AT-74), does A/T shift from D ₃ to D ₄ at the specified speed?			
 <p>Accelerator pedal</p> <p>Halfway</p>			
Yes or No			
Yes	▶	GO TO 10.	
No	▶	GO TO 2.	

SAT988H

2	CHECK LINE PRESSURE		
Perform line pressure test. Refer to "Line Pressure Test", AT-65.			
OK or NG			
OK	▶	GO TO 3.	
NG	▶	GO TO 6.	

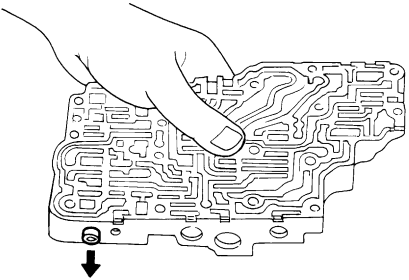
3	CHECK CONTROL VALVE		
1. Disassemble control valve assembly. Refer to "Control Valve Assembly", AT-302. 2. Check to ensure that:			
<ul style="list-style-type: none"> ● Valve, sleeve and plug slide along valve bore under their own weight. ● Valve, sleeve and plug are free from burrs, dents and scratches. ● Control valve springs are free from damage, deformation and fatigue. ● Hydraulic line is free from obstacles. 			
			
OK or NG			
OK	▶	GO TO 4.	
NG	▶	Repair control valve.	

SAT367H

DTC P0744 A/T TCC S/V FUNCTION (LOCK-UP)

Diagnostic Procedure (Cont'd)

4	CHECK SHIFT UP (D₃ TO D₄)
Does A/T shift from D ₃ to D ₄ at the specified speed?	
OK or NG	
OK	▶ GO TO 5.
NG	▶ Check control valve again. Repair or replace control valve assembly.

5	CHECK DTC
Perform "DIAGNOSTIC TROUBLE CODE (DTC) CONFIRMATION PROCEDURE", AT-160.	
OK or NG	
OK	▶ INSPECTION END
NG	▶ GO TO 10. Check for proper lock-up.

6	CHECK LINE PRESSURE SOLENOID VALVE
<ol style="list-style-type: none"> Remove control valve assembly. Refer to "Control Valve Assembly and Accumulators", AT-270. Check line pressure solenoid valve operation. Refer to "Component Inspection", AT-166. 	
OK or NG	
OK	▶ GO TO 7.
NG	▶ Replace solenoid valve assembly.

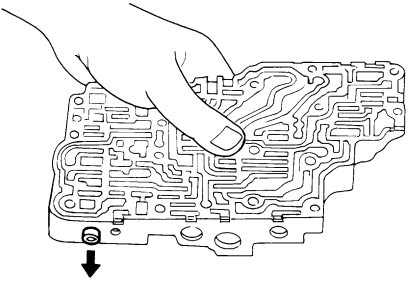
7	CHECK CONTROL VALVE
<ol style="list-style-type: none"> Disassemble control valve assembly. Refer to "Control Valve Assembly", AT-302. Check line pressure circuit valves for sticking. <ul style="list-style-type: none"> ● Pressure regulator valve ● Pilot valve ● Pressure modifier valve 	
	
SAT367H	
OK or NG	
OK	▶ GO TO 8.
NG	▶ Repair control valve.

8	CHECK SHIFT UP (D₃ TO D₄)
Does A/T shift from D ₃ to D ₄ at the specified speed?	
OK or NG	
OK	▶ GO TO 9.
NG	▶ Check control valve again. Repair or replace control valve assembly.

GI
MA
EM
LC
EC
FE
AT
AX
SU
BR
ST
RS
BT
HA
SC
EL
IDX

DTC P0744 A/T TCC S/V FUNCTION (LOCK-UP)

Diagnostic Procedure (Cont'd)

9	CHECK DTC	
Perform "DIAGNOSTIC TROUBLE CODE (DTC) CONFIRMATION PROCEDURE", AT-160.		
OK or NG		
OK	▶	INSPECTION END
NG	▶	GO TO 10. Check for proper lock-up.

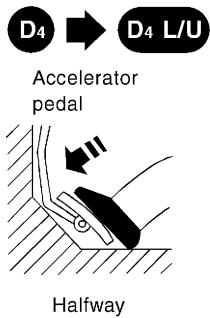
10	CHECK LOCK-UP	
During "Cruise test – Part 1" (AT-74), does A/T perform lock-up at the specified speed?		
		
SAT989H		
Yes or No		
Yes	▶	Perform "Cruise test – Part 1" again and return to the start point of this flow chart.
No	▶	GO TO 11.

11	CHECK TORQUE CONVERTER CLUTCH SOLENOID VALVE	
<ol style="list-style-type: none"> 1. Remove control valve assembly. Refer to "Control Valve Assembly and Accumulators", AT-270. 2. Check torque converter clutch solenoid valve operation. Refer to "Component Inspection", AT-166. 		
OK or NG		
OK	▶	GO TO 12.
NG	▶	Replace solenoid valve assembly.

DTC P0744 A/T TCC S/V FUNCTION (LOCK-UP)

Diagnostic Procedure (Cont'd)

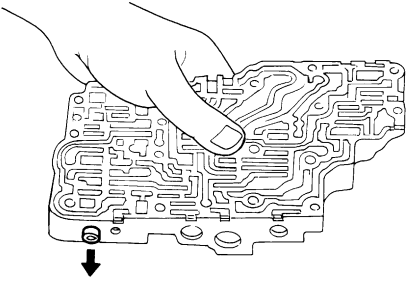
12	CHECK CONTROL VALVE	<p>1. Disassemble control valve assembly. Refer to "Control Valve Assembly", AT-302.</p> <p>2. Check control valves for sticking.</p> <ul style="list-style-type: none"> ● Torque converter clutch control valve ● Torque converter clutch relief valve 	
			
		SAT367H	
OK or NG			
OK	▶	GO TO 13.	
NG	▶	Repair control valve.	

GI
MA
EM
LC
EC
FE

AT

AX

13	CHECK LOCK-UP	Does A/T perform lock-up at the specified speed?	
		Yes or No	
Yes	▶	GO TO 14.	
No	▶	Check control valve again. Repair or replace control valve assembly.	

SU

BR

ST

14	CHECK DTC	Perform "DIAGNOSTIC TROUBLE CODE (DTC) CONFIRMATION PROCEDURE", AT-160.	
		OK or NG	
OK	▶	INSPECTION END	
NG	▶	Perform "Cruise test — Part 1" again and return to the start point of this flow chart.	

RS

BT

HA

SC

EL

IDX

DTC P0744 A/T TCC S/V FUNCTION (LOCK-UP)

Component Inspection

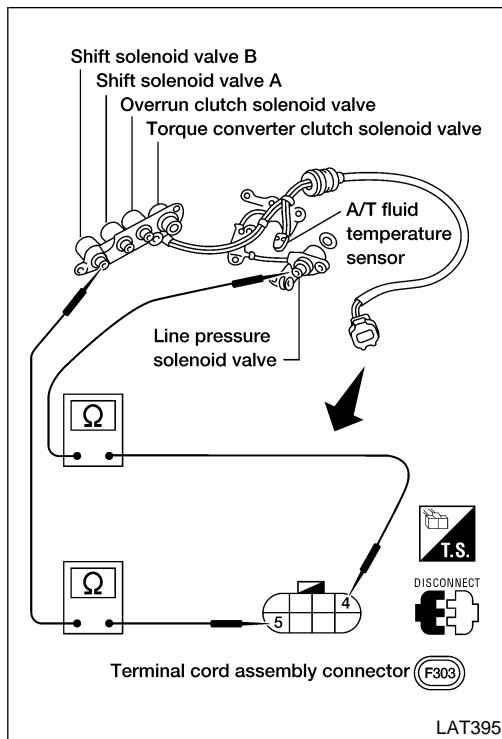

Component Inspection

SOLENOID VALVES

=NDAT0063

NDAT0063S01

- For removal, refer to "Control Valve Assembly and Accumulators", AT-270.

Resistance Check

NDAT0063S0101

- Check resistance between two terminals.

Solenoid valve	Terminal No.		Resistance (Approx.)
Line pressure solenoid valve	4	Ground	2.5 - 5Ω
Torque converter clutch solenoid valve	5		10 - 16Ω

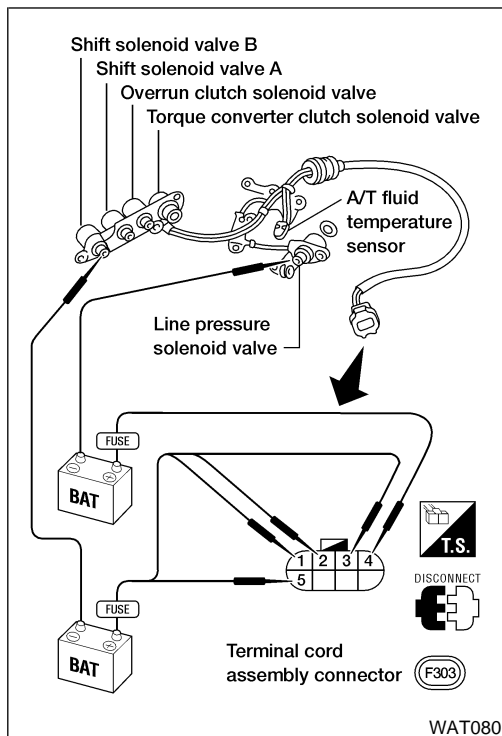

Operation Check

NDAT0063S0102

- Check solenoid valve by listening for its operating sound while applying battery voltage to the terminal and ground.

DTC P0745 LINE PRESSURE SOLENOID VALVE

Description

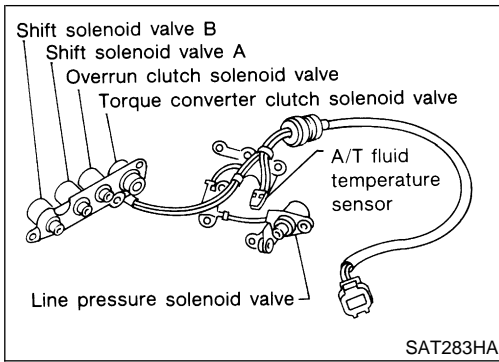

Description

The line pressure solenoid valve regulates the oil pump discharge pressure to suit the driving condition in response to a signal sent from the TCM. NDAT0064

The line pressure duty cycle value is not consistent when the closed throttle position switch is ON. To confirm the line pressure duty cycle at low pressure, the accelerator (throttle) should be open until the closed throttle position switch is OFF.

CONSULT-II REFERENCE VALUE IN DATA MONITOR MODE

NDAT0064S01

Remarks: Specification data are reference values.

Monitor item	Condition	Specification (Approx.)
Line pressure solenoid valve duty	Small throttle opening (Low line pressure)	24%
	Large throttle opening (High line pressure)	95%

NOTE:

The line pressure duty cycle value is not consistent when the closed throttle position switch is ON. To confirm the line pressure duty cycle at low pressure, the accelerator (throttle) should be open until the closed throttle position switch is OFF.

TCM TERMINALS AND REFERENCE VALUE

NDAT0064S02

Remarks: Specification data are reference values.

Terminal No.	Wire color	Item	Condition	Judgement standard (Approx.)
1	G/R	Line pressure solenoid valve	When releasing accelerator pedal after warming up engine.	1.5 - 2.5V
			When depressing accelerator pedal fully after warming up engine.	0V
2	Y/B	Line pressure solenoid valve (with dropping resistor)	When releasing accelerator pedal after warming up engine.	4 - 14V
			When depressing accelerator pedal fully after warming up engine.	0V

ON BOARD DIAGNOSIS LOGIC

NDAT0064S03

Diagnostic trouble code	Malfunction is detected when ...	Check items (Possible cause)
(P) : L/PRESS SOL/CIRC (SST) : P0745 (NO TOOLS) : MIL Code No. 1205	TCM detects an improper voltage drop when it tries to operate the solenoid valve.	<ul style="list-style-type: none"> Harness or connectors (The solenoid circuit is open or shorted.) Line pressure solenoid valve

DTC P0745 LINE PRESSURE SOLENOID VALVE

Description (Cont'd)

SELECT SYSTEM
A/T
ENGINE

SAT014K

SELECT DIAG MODE
WORK SUPPORT
SELF-DIAG RESULTS
DATA MONITOR
DATA MONITOR (SPEC)
ACTIVE TEST
DTC & SRT CONFIRMATION

SEF949Y

DIAGNOSTIC TROUBLE CODE (DTC) CONFIRMATION PROCEDURE

NDAT0064S04

NOTE:

If "DIAGNOSTIC TROUBLE CODE CONFIRMATION PROCEDURE" has been previously conducted, always turn ignition switch OFF and wait at least 5 seconds before conducting the next test.

After the repair, perform the following procedure to confirm the malfunction is eliminated.

With CONSULT-II

- 1) Turn ignition switch ON and select "DATA MONITOR" mode for "ENGINE" with CONSULT-II.
- 2) Depress accelerator pedal completely and wait at least 1 second.

With GST

Follow the procedure "With CONSULT-II".

DTC P0745 LINE PRESSURE SOLENOID VALVE

Wiring Diagram — AT — LPSV

Wiring Diagram — AT — LPSV

NDAT0207

AT-LPSV-01

GI

MA

EM

LC

EC

FE

AT

AX

SU

BR

ST

RS

BT

HA

SC

EL

IDX

: Detectable line for DTC
 : Non-detectable line for DTC

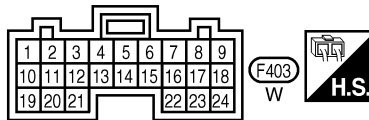
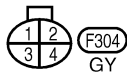
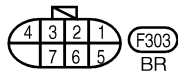
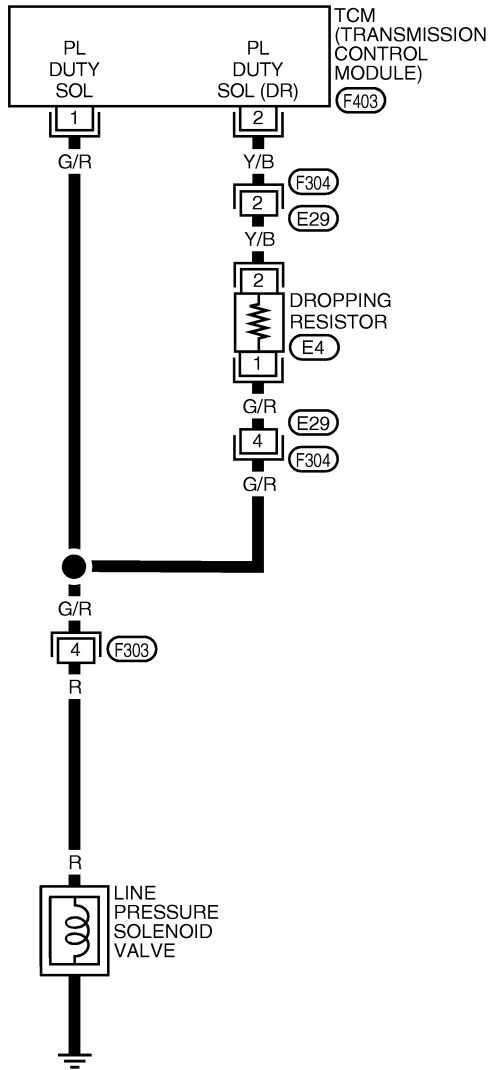

DTC P0745 LINE PRESSURE SOLENOID VALVE

Diagnostic Procedure

Diagnostic Procedure

NDAT0065

1	CHECK VALVE RESISTANCE
<p>1. Turn ignition switch to OFF position. 2. Disconnect terminal cord assembly connector in engine compartment. 3. Check resistance between terminal 4 and ground.</p> <div style="text-align: center;"> <p>Terminal cord assembly connector (F303)</p> </div> <p style="text-align: right;">AAT369A</p> <p>Resistance: 2.5 - 5Ω</p> <p style="text-align: center;">OK or NG</p>	
OK	▶ GO TO 2.
NG	▶ <ol style="list-style-type: none"> 1. Remove control valve assembly. Refer to “Control Valve Assembly and Accumulators”, AT-270. 2. Check the following items: <ul style="list-style-type: none"> ● Line pressure solenoid valve Refer to “Component Inspection”, AT-172. ● Harness of terminal cord assembly for short or open

2	CHECK POWER SOURCE AND DROPPING RESISTOR CIRCUIT
<p>1. Turn ignition switch to OFF position. 2. Disconnect TCM harness connector. 3. Check resistance between terminal cord assembly harness connector F303 terminal 4 (G/R) and TCM harness connector F403 terminal 2 (Y/B).</p> <div style="text-align: center;"> <p>Harness connector TCM connector</p> </div> <p style="text-align: right;">Resistance: 11.2 - 12.8 Ω</p> <p style="text-align: right;">LAT389</p> <p style="text-align: center;">OK or NG</p>	
OK	▶ GO TO 3.
NG	▶ <p>Check the following items:</p> <ul style="list-style-type: none"> ● Dropping resistor Refer to “Component Inspection”, AT-172. ● Harness for short or open between TCM terminal 2 and terminal cord assembly (Main harness)

DTC P0745 LINE PRESSURE SOLENOID VALVE

Diagnostic Procedure (Cont'd)

3	CHECK POWER SOURCE CIRCUIT	
<p>1. Turn ignition switch to OFF position. 2. Check continuity between terminal 4 and TCM harness connector terminal 1.</p>		
<p>Continuity should exist. If OK, check harness for short to ground and short to power. 3. Reinstall any part removed.</p>		
AAT371A		
OK or NG		
OK	▶	GO TO 4.
NG	▶	Repair open circuit or short to ground or short to power in harness or connectors.

4	CHECK DTC	
<p>Perform "DIAGNOSTIC TROUBLE CODE (DTC) CONFIRMATION PROCEDURE", AT-168.</p>		
OK or NG		
OK	▶	INSPECTION END
NG	▶	<p>1. Perform TCM input/output signal inspection. 2. If NG, recheck TCM pin terminals for damage or loose connection with harness connector.</p>

GI

MA

EM

LC

EC

FE

AT

AX

SU

BR

ST

RS

BT

HA

SC

EL

IDX

DTC P0745 LINE PRESSURE SOLENOID VALVE

Component Inspection

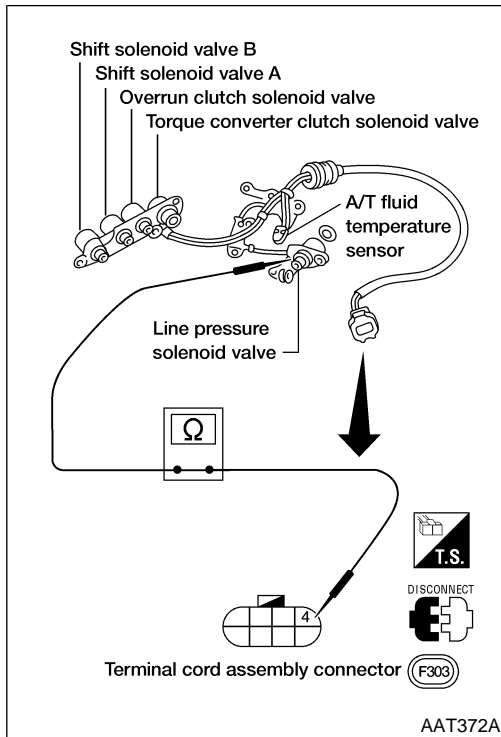

Component Inspection

LINE PRESSURE SOLENOID VALVE

=NDAT0066

NDAT0066S01

- For removal, refer to "Control Valve Assembly and Accumulators", AT-270.

Resistance Check

NDAT0066S0101

- Check resistance between two terminals.

Solenoid valve	Terminal No.		Resistance (Approx.)
Line pressure solenoid valve	4	Ground	2.5 - 5Ω

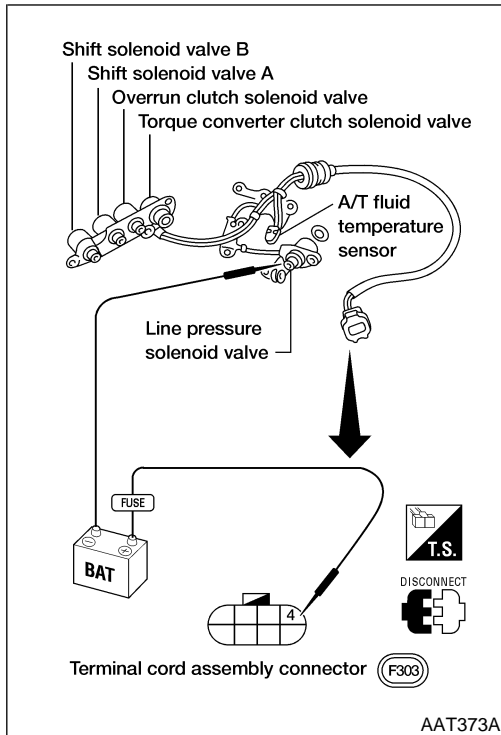

Operation Check

NDAT0066S0102

- Check solenoid valve by listening for its operating sound while applying battery voltage to the terminal and ground.

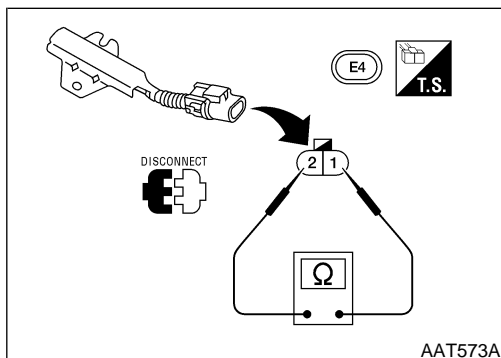

DROPPING RESISTOR

NDAT0066S02

- Check resistance between two terminals.

Resistance: 10 - 15Ω

DTC P0750 SHIFT SOLENOID VALVE A

Description

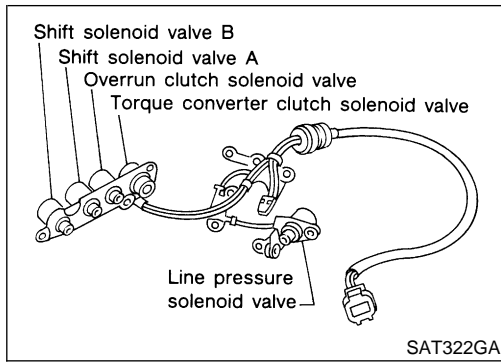

Description

Shift solenoid valves A and B are turned ON or OFF by the TCM^{NDAT0067} in response to signals sent from the park/neutral position (PNP) switch, vehicle speed and throttle position sensors. Gears will then be shifted to the optimum position.

Gear position	1	2	3	4
Shift solenoid valve A	ON (Closed)	OFF (Open)	OFF (Open)	ON (Closed)
Shift solenoid valve B	ON (Closed)	ON (Closed)	OFF (Open)	OFF (Open)

TCM TERMINALS AND REFERENCE VALUE



NDAT0067S01

Remarks: Specification data are reference values.

Terminal No.	Wire color	Item	Condition	Judgement standard (Approx.)
11	Y/PU	Shift solenoid valve A	 When shift solenoid valve A operates. (When driving in D ₁ or D ₄ .)	Battery voltage
			When shift solenoid valve A does not operate. (When driving in D ₂ or D ₃ .)	0V

ON BOARD DIAGNOSIS LOGIC

NDAT0067S02

Diagnostic trouble code	Malfunction is detected when ...	Check items (Possible cause)
 : SFT SOL A/CIRC	TCM detects an improper voltage drop when it tries to operate the solenoid valve.	<ul style="list-style-type: none"> ● Harness or connectors (The solenoid circuit is open or shorted.) ● Shift solenoid valve A
 : P0750		
 : MIL Code No. 1108		

DTC P0750 SHIFT SOLENOID VALVE A

Description (Cont'd)

SELECT SYSTEM
A/T
ENGINE

SAT014K

SELECT DIAG MODE
WORK SUPPORT
SELF-DIAG RESULTS
DATA MONITOR
DATA MONITOR (SPEC)
ACTIVE TEST
DTC & SRT CONFIRMATION

SEF949Y

DIAGNOSTIC TROUBLE CODE (DTC) CONFIRMATION PROCEDURE

NDAT0067S03

CAUTION:

Always drive vehicle at a safe speed.

NOTE:

If "DIAGNOSTIC TROUBLE CODE CONFIRMATION PROCEDURE" has been previously conducted, always turn ignition switch OFF and wait at least 5 seconds before conducting the next test.

After the repair, perform the following procedure to confirm the malfunction is eliminated.

With CONSULT-II

- 1) Turn ignition switch ON and select "DATA MONITOR" mode for "ENGINE" with CONSULT-II.
- 2) Start engine.
- 3) Drive vehicle in D position and allow the transmission to shift 1 → 2 ("GEAR").

With GST

Follow the procedure "With CONSULT-II".

DTC P0750 SHIFT SOLENOID VALVE A

Wiring Diagram — AT — SSV/A

Wiring Diagram — AT — SSV/A

NDAT0208

AT-SSV/A-01

GI

— : Detectable line for DTC
 - - - : Non-detectable line for DTC

MA

EM

LC

EC

FE

AT

AX

SU

BR

ST

RS

BT

HA

SC

EL

IDX

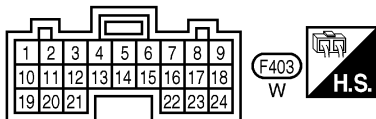
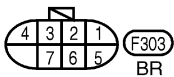
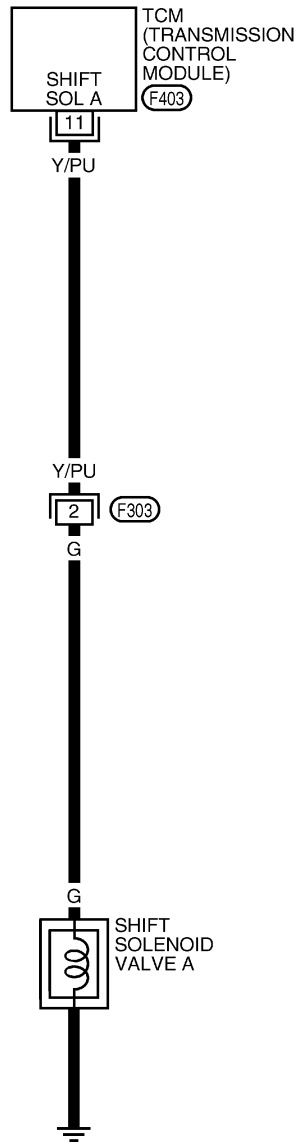

DTC P0750 SHIFT SOLENOID VALVE A

Diagnostic Procedure

Diagnostic Procedure

NDAT0068

1	CHECK CHECK VALVE RESISTANCE	
<p>1. Turn ignition switch to OFF position. 2. Disconnect terminal cord assembly connector in engine compartment. 3. Check resistance between terminal 2 and ground.</p> <div style="text-align: center;"> <p>Terminal cord assembly connector (F303)</p> <p>Resistance: 20 - 40Ω</p> <p>OK or NG</p> </div>		
OK	▶	GO TO 2.
NG	▶	<p>1. Remove control valve assembly. Refer to "Control Valve Assembly and Accumulators", AT-270. 2. Check the following items:</p> <ul style="list-style-type: none"> ● Shift solenoid valve A Refer to "Component Inspection", AT-178. ● Harness of terminal cord assembly for short or open

2	CHECK POWER SOURCE CIRCUIT	
<p>1. Turn ignition switch to OFF position. 2. Disconnect TCM harness connector. 3. Check continuity between terminal 2 and TCM harness connector terminal 11. Continuity should exist.</p> <div style="text-align: center;"> <p>Harness connector (F303) TCM connector (F403)</p> <p>Continuity should exist.</p> </div> <p>If OK, check harness for short to ground and short to power.</p> <p>4. Reinstall any part removed.</p> <p style="text-align: center;">OK or NG</p>		
OK	▶	GO TO 3.
NG	▶	Repair open circuit or short to ground or short to power in harness or connectors.

DTC P0750 SHIFT SOLENOID VALVE A

Diagnostic Procedure (Cont'd)

3	CHECK DTC
Perform "DIAGNOSTIC TROUBLE CODE (DTC) CONFIRMATION PROCEDURE", AT-174.	
OK or NG	
OK	▶ INSPECTION END
NG	▶ 1. Perform TCM input/output signal inspection. 2. If NG, recheck TCM pin terminals for damage or loose connection with harness connector.

GI

MA

EM

LC

EC

FE

AT

AX

SU

BR

ST

RS

BT

HA

SC

EL

IDX

DTC P0750 SHIFT SOLENOID VALVE A

Component Inspection

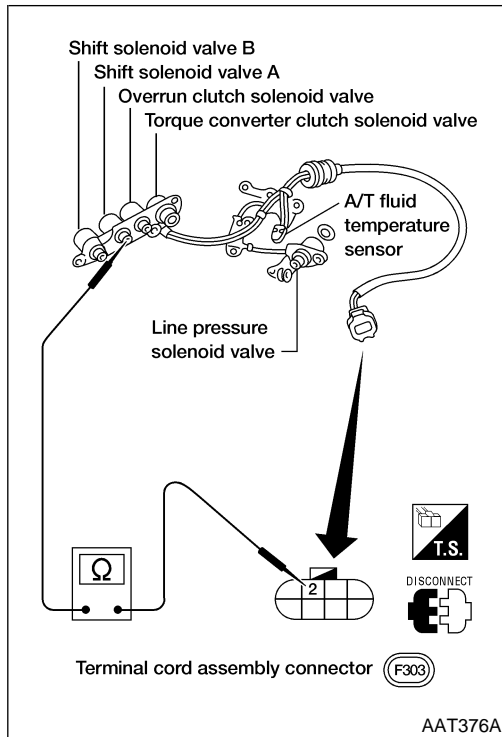

Component Inspection SHIFT SOLENOID VALVE A

=NDAT0069

NDAT0069S01

- For removal, refer to "Control Valve Assembly and Accumulators", AT-270.

Resistance Check

NDAT0069S0101

- Check resistance between two terminals.

Solenoid valve	Terminal No.		Resistance (Approx.)
	1	2	
Shift solenoid valve A	2	Ground	20 - 40Ω

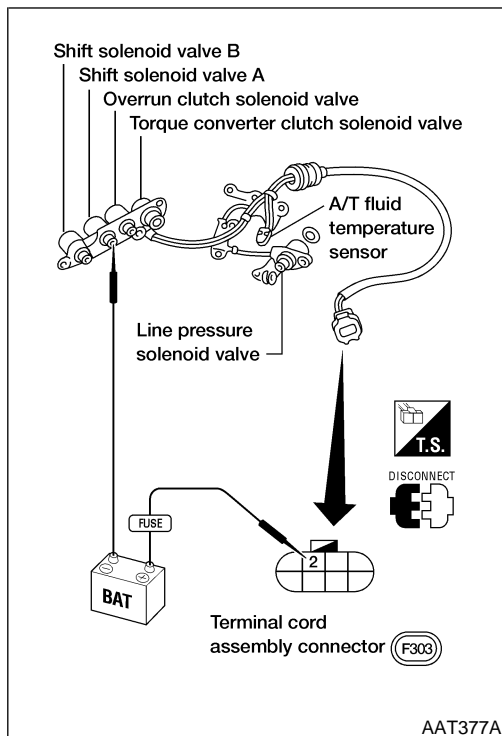

Operation Check

NDAT0069S0102

- Check solenoid valve by listening for its operating sound while applying battery voltage to the terminal and ground.

DTC P0755 SHIFT SOLENOID VALVE B

Description

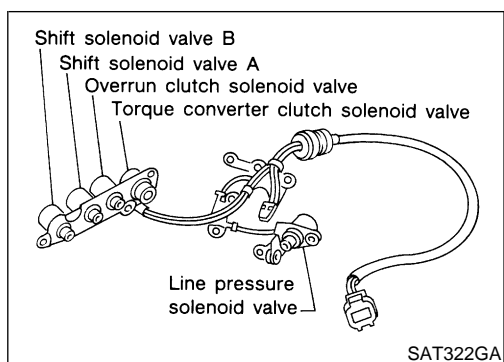

Description

Shift solenoid valves A and B are turned ON or OFF by the TCM ^{NDAT0070} in response to signals sent from the park/neutral position (PNP) switch, vehicle speed and throttle position sensors. Gears will then be shifted to the optimum position.

Gear position	1	2	3	4
Shift solenoid valve A	ON (Closed)	OFF (Open)	OFF (Open)	ON (Closed)
Shift solenoid valve B	ON (Closed)	ON (Closed)	OFF (Open)	OFF (Open)

TCM TERMINALS AND REFERENCE VALUE



NDAT0070S01

Remarks: Specification data are reference values.

Terminal No.	Wire color	Item	Condition	Judgement standard (Approx.)
12	Y/G	Shift solenoid valve B	 When shift solenoid valve B operates. (When driving in D ₁ or D ₂ .)	Battery voltage
			When shift solenoid valve B does not operate. (When driving in D ₃ or D ₄ .)	0V

ON BOARD DIAGNOSIS LOGIC

NDAT0070S02

Diagnostic trouble code	Malfunction is detected when ...	Check items (Possible cause)
 : SFT SOL B/CIRC	TCM detects an improper voltage drop when it tries to operate the solenoid valve.	<ul style="list-style-type: none"> • Harness or connectors (The solenoid circuit is open or shorted.) • Shift solenoid valve B
 : P0755		
 : MIL Code No. 1201		

DTC P0755 SHIFT SOLENOID VALVE B

Description (Cont'd)

SELECT SYSTEM
A/T
ENGINE

SAT014K

SELECT DIAG MODE
WORK SUPPORT
SELF-DIAG RESULTS
DATA MONITOR
DATA MONITOR (SPEC)
ACTIVE TEST
DTC & SRT CONFIRMATION

SEF949Y

DIAGNOSTIC TROUBLE CODE (DTC) CONFIRMATION PROCEDURE

NDAT0070S03

CAUTION:

Always drive vehicle at a safe speed.

NOTE:

If "DIAGNOSTIC TROUBLE CODE CONFIRMATION PROCEDURE" has been previously conducted, always turn ignition switch OFF and wait at least 5 seconds before conducting the next test.

After the repair, perform the following procedure to confirm the malfunction is eliminated.

With CONSULT-II

- 1) Turn ignition switch ON and select "DATA MONITOR" mode for "ENGINE" with CONSULT-II.
- 2) Start engine.
- 3) Drive vehicle in D position and allow the transmission to shift 1 → 2 → 3 ("GEAR").

With GST

Follow the procedure "With CONSULT-II".

DTC P0755 SHIFT SOLENOID VALVE B

Wiring Diagram — AT — SSV/B

Wiring Diagram — AT — SSV/B

NDAT0209

AT-SSV/B-01

GI

MA

EM

LC

EC

FE

AT

AX

SU

BR

ST

RS

BT

HA

SC

EL

IDX

— : Detectable line for DTC
 - - - : Non-detectable line for DTC

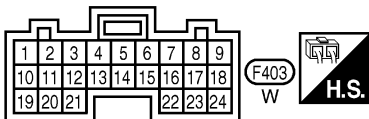
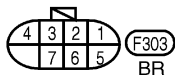
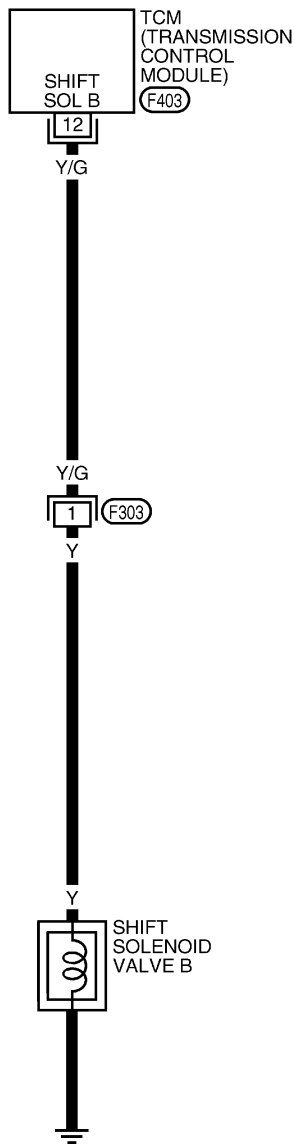

DTC P0755 SHIFT SOLENOID VALVE B

Diagnostic Procedure

Diagnostic Procedure

NDAT0071

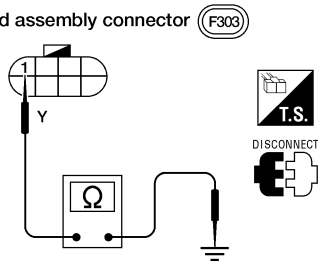
1	CHECK VALVE RESISTANCE	
<p>1. Turn ignition switch to OFF position. 2. Disconnect terminal cord assembly connector in engine compartment. 3. Check resistance between terminal 1 and ground.</p>		
<p>Terminal cord assembly connector (F303)</p> 		
<p>Resistance: 20 - 40Ω</p>		
OK or NG		
OK	▶	GO TO 2.
NG	▶	<p>1. Remove control valve assembly. Refer to “Control Valve Assembly and Accumulators”, AT-270. 2. Check the following items:</p> <ul style="list-style-type: none"> ● Shift solenoid valve B Refer to “Component Inspection”, AT-184. ● Harness of terminal cord assembly for short or open

AAT378A

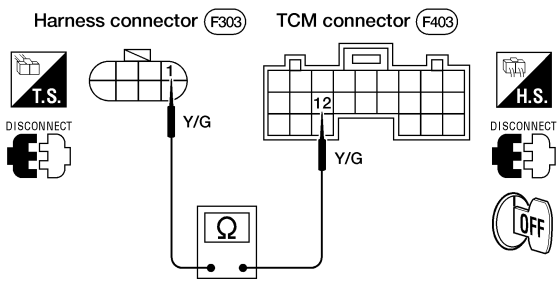
2	CHECK POWER SOURCE CIRCUIT	
<p>1. Turn ignition switch to OFF position. 2. Disconnect TCM harness connector. 3. Check continuity between terminal 1 and TCM harness connector terminal 12.</p>		
<p>Harness connector (F303) TCM connector (F403)</p> 		
<p>Continuity should exist.</p> <p>If OK, check harness for short to ground and short to power.</p>		
<p>4. Reinstall any part removed.</p>		
OK or NG		
OK	▶	GO TO 3.
NG	▶	Repair open circuit or short to ground or short to power in harness or connectors.

AAT379A

DTC P0755 SHIFT SOLENOID VALVE B

Diagnostic Procedure (Cont'd)

3	CHECK DTC	
Perform "DIAGNOSTIC TROUBLE CODE (DTC) CONFIRMATION PROCEDURE", AT-180.		
OK or NG		
OK	▶	INSPECTION END
NG	▶	<ol style="list-style-type: none"> 1. Perform TCM input/output signal inspection. 2. If NG, recheck TCM pin terminals for damage or loose connection with harness connector.

GI

MA

EM

LC

EC

FE

AT

AX

SU

BR

ST

RS

BT

HA

SC

EL

IDX

DTC P0755 SHIFT SOLENOID VALVE B

Component Inspection

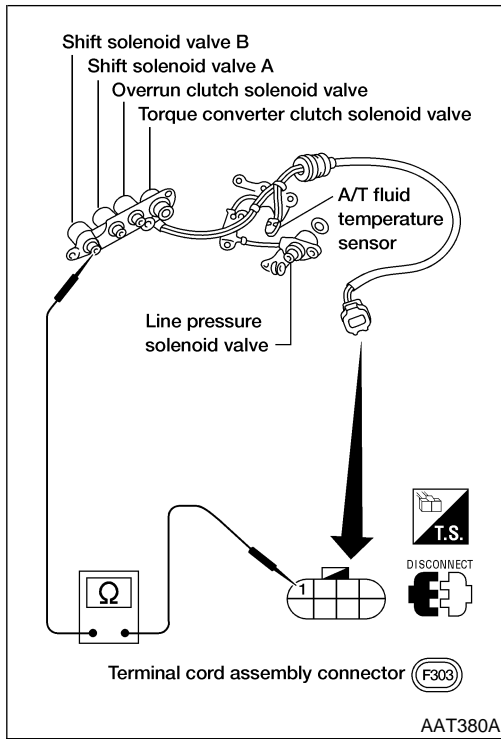

Component Inspection SHIFT SOLENOID VALVE B

=NDAT0072

NDAT0072S01

- For removal, refer to "Control Valve Assembly and Accumulators", AT-270.

Resistance Check

NDAT0072S0101

- Check resistance between two terminals.

Solenoid valve	Terminal No.		Resistance (Approx.)
	1	Ground	
Shift solenoid valve B	1	Ground	20 - 40Ω

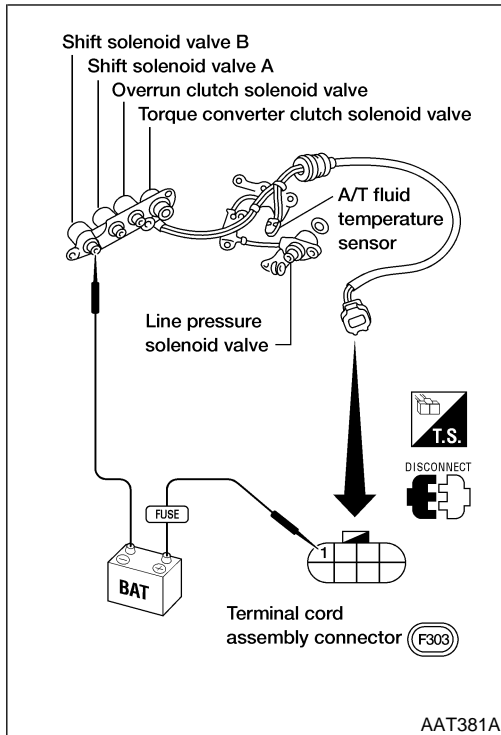

Operation Check

NDAT0072S0102

- Check solenoid valve by listening for its operating sound while applying battery voltage to the terminal and ground.

DTC P1705 THROTTLE POSITION SENSOR

Description

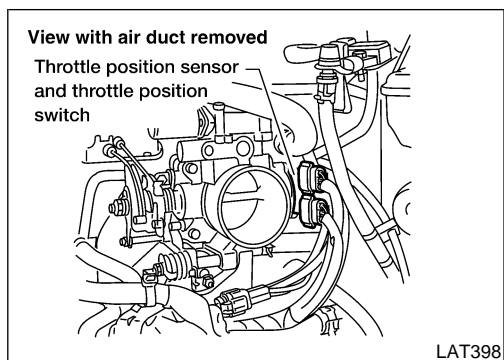

Description

NDAT0073

- Throttle position sensor
The throttle position sensor detects the throttle valve position and sends a signal to the TCM.
- Throttle position switch
Consists of a wide open throttle position switch and a closed throttle position switch.
The wide open throttle position switch sends a signal to the TCM when the throttle valve is open at least 1/2 of the full throttle position. The closed throttle position switch sends a signal to the TCM when the throttle valve is fully closed.

CONSULT-II REFERENCE VALUE IN DATA MONITOR MODE

NDAT0073S01

Remarks: Specification data are reference values.

Monitor item	Condition	Specification (Approx.)
Throttle position sensor	Fully-closed throttle	0.5V
	Fully-open throttle	4V

TCM TERMINALS AND REFERENCE VALUE

NDAT0073S02

Remarks: Specification data are reference values.

Terminal No.	Wire color	Item	Condition	Judgement standard (Approx.)
16	BR/Y	Closed throttle position switch (in throttle position switch)	When releasing accelerator pedal after warming up engine.	Battery voltage
			When depressing accelerator pedal after warming up engine.	0V
17	R/W	Wide open throttle position switch (in throttle position switch)	When depressing accelerator pedal more than half-way after warming up engine.	Battery voltage
			When releasing accelerator pedal after warming up engine.	0V
32	BR	Throttle position sensor (Power source)	Ignition switch "ON".	4.5 - 5.5V
			Ignition switch "OFF".	0V
41	R/G	Throttle position sensor	When depressing accelerator pedal slowly after warming up engine. (Voltage rises gradually in response to throttle position.)	Fully-closed throttle: 0.5V Fully-open throttle: 4V
42	B/Y	Throttle position sensor (Ground)	—	—

ON BOARD DIAGNOSIS LOGIC

NDAT0073S03

Diagnostic trouble code	Malfunction is detected when ...	Check items (Possible cause)
(P) : TP SEN/CIRC A/T (P) : P1705 (MIL) : MIL Code No. 1206	TCM receives an excessively low or high voltage from the sensor.	<ul style="list-style-type: none"> ● Harness or connectors (The sensor circuit is open or shorted.) ● Throttle position sensor ● Throttle position switch

DTC P1705 THROTTLE POSITION SENSOR

Description (Cont'd)

SELECT SYSTEM
A/T
ENGINE

SAT014K

SELECT DIAG MODE
SELF-DIAG RESULTS
DATA MONITOR
DTC WORK SUPPORT
TCM PART NUMBER

SAT971J

SELECT SYSTEM
A/T
ENGINE

SAT014K

SELECT DIAG MODE
WORK SUPPORT
SELF-DIAG RESULTS
DATA MONITOR
DATA MONITOR (SPEC)
ACTIVE TEST
DTC & SRT CONFIRMATION

SEF949Y

DIAGNOSTIC TROUBLE CODE (DTC) CONFIRMATION PROCEDURE

NDAT0073S04

CAUTION:

Always drive vehicle at a safe speed.

NOTE:

If "DIAGNOSTIC TROUBLE CODE CONFIRMATION PROCEDURE" has been previously conducted, always turn ignition switch OFF and wait at least 5 seconds before conducting the next test.

After the repair, perform the following procedure to confirm the malfunction is eliminated.

With CONSULT-II

- 1) Turn ignition switch ON and select "TCM INPUT SIGNALS" in "DATA MONITOR" mode for "A/T" with CONSULT-II.
- 2) Check the following.

Accelerator pedal condition	THRTL POS SEN	CLOSED THL/SW	W/O THRL/P-SW
Fully released	Less than 4.7V	ON	OFF
Partially depressed	0.1 - 4.6V	OFF	OFF
Fully depressed	1.9 - 4.6V	OFF	ON

If the check result is NG, go to "DIAGNOSTIC PROCEDURE", AT-188.

If the check result is OK, go to following step.

- 3) Turn ignition switch ON and select "DATA MONITOR" mode for "ENGINE" with CONSULT-II.
- 4) Start engine and maintain the following conditions for at least 3 consecutive seconds. Then release accelerator pedal completely.

VHCL SPEED SE: 10 km/h (6 MPH) or more

THRTL POS SEN: Approximately 3V or less

Selector lever: D position (O/D ON)

If the check result is NG, go to "DIAGNOSTIC PROCEDURE", AT-188.

If the check result is OK, go to following step.

- 5) Maintain the following conditions for at least 3 consecutive seconds. Then release accelerator pedal completely.

VHCL SPEED SE: 10 km/h (6 MPH) or more

Accelerator pedal: Wide open throttle

Selector lever: D position (O/D ON)

With GST

Follow the procedure "With CONSULT-II".

DTC P1705 THROTTLE POSITION SENSOR

Wiring Diagram — AT — TPS

Wiring Diagram — AT — TPS

NDAT0210

AT-TPS-01

GI

MA

EM

LC

EC

FE

AT

AX

SU

BR

ST

RS

BT

HA

SC

EL

IDX

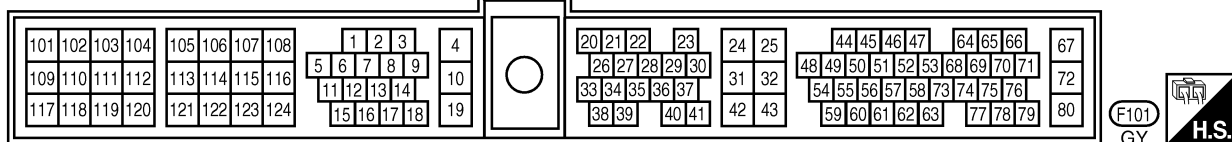
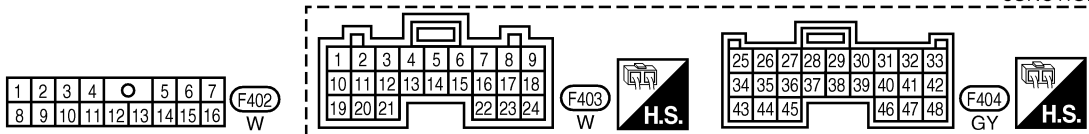
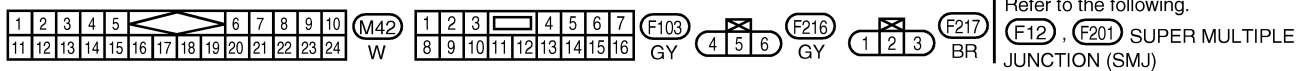
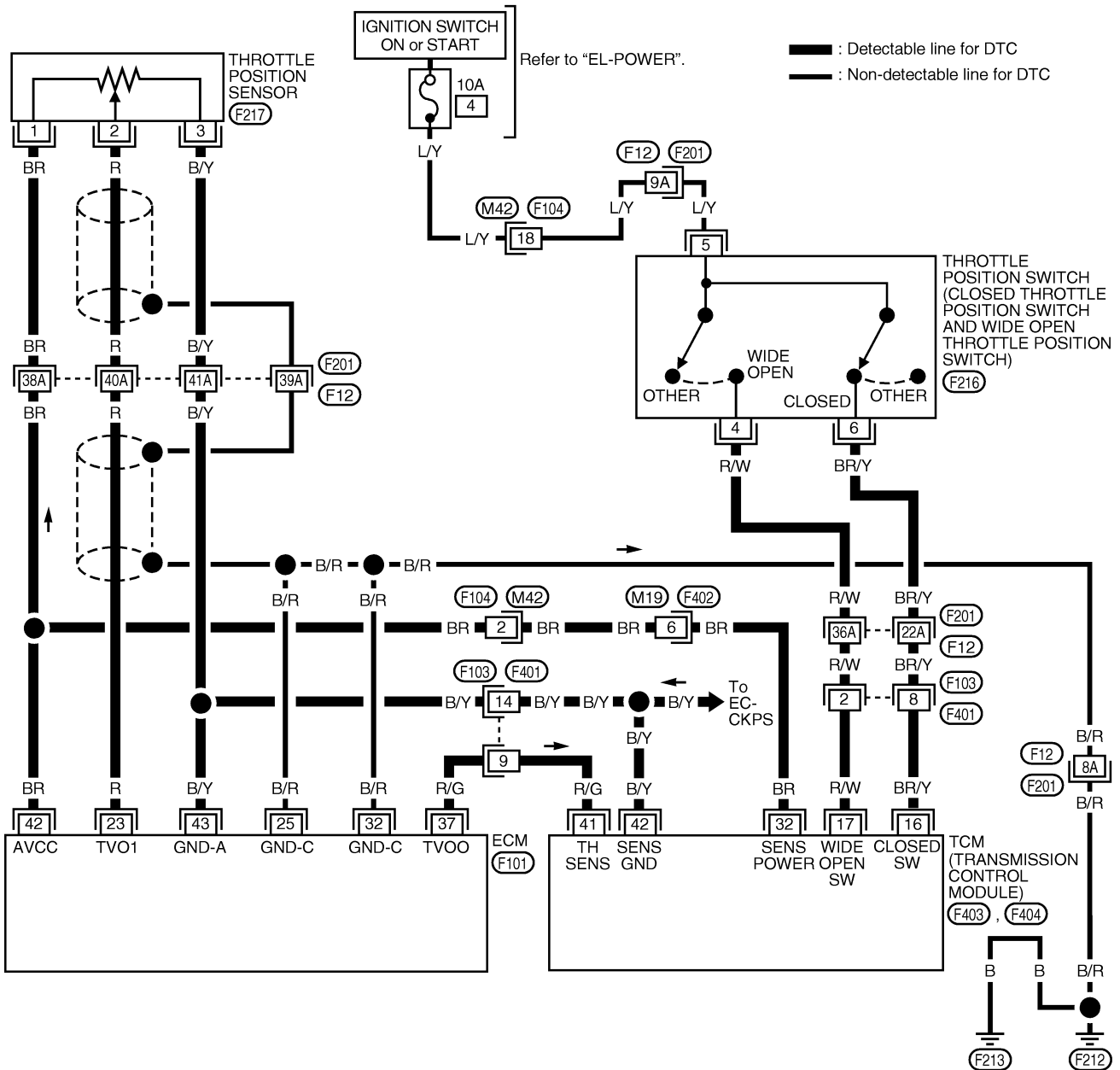

WAT060

DTC P1705 THROTTLE POSITION SENSOR

Diagnostic Procedure

Diagnostic Procedure

NDAT0074

1	CHECK DTC WITH ECM
Perform diagnostic test mode II (self-diagnostic results) for engine control. Refer to EC-63 , "Malfunction Indicator Lamp (MIL)".	
OK or NG	
OK (with CONSULT-II) ▶	GO TO 2.
OK (without CONSULT-II) ▶	GO TO 3.
NG ▶	Check throttle position sensor circuit for engine control. Refer to EC-160 , "Throttle Position Sensor (DTC: 0403)".

2	CHECK INPUT SIGNAL (With CONSULT-II)														
<p> With CONSULT-II</p> <p>1. Turn ignition switch to ON position. (Do not start engine.)</p> <p>2. Select "TCM INPUT SIGNALS" in "DATA MONITOR" mode for "A/T" with CONSULT-II.</p>															
<table border="1"> <tr><td style="text-align: center;">SELECT SYSTEM</td></tr> <tr><td style="text-align: center;">A/T</td></tr> <tr><td style="text-align: center;">ENGINE</td></tr> <tr><td> </td></tr> <tr><td> </td></tr> <tr><td> </td></tr> <tr><td> </td></tr> <tr><td> </td></tr> <tr><td> </td></tr> </table>		SELECT SYSTEM	A/T	ENGINE											
SELECT SYSTEM															
A/T															
ENGINE															
<p>3. Read out the value of "THRTL POS SEN".</p> <p>Voltage:</p> <p>Fully-closed throttle: Approximately 0.5V</p> <p>Fully-open throttle: Approximately 4V</p>															
<table border="1"> <tr><td colspan="2" style="text-align: center;">DATA MONITOR</td></tr> <tr><td style="text-align: center;">MONITORING</td><td> </td></tr> <tr><td>VHCL/S SE-A/T</td><td>XXX km/h</td></tr> <tr><td>VHCL/S SE-MTR</td><td>XXX km/h</td></tr> <tr><td>THRTL POS SEN</td><td>XXX V</td></tr> <tr><td>FLUID TEMP SE</td><td>XXX V</td></tr> <tr><td>BATTERY VOLT</td><td>XXX V</td></tr> </table>		DATA MONITOR		MONITORING		VHCL/S SE-A/T	XXX km/h	VHCL/S SE-MTR	XXX km/h	THRTL POS SEN	XXX V	FLUID TEMP SE	XXX V	BATTERY VOLT	XXX V
DATA MONITOR															
MONITORING															
VHCL/S SE-A/T	XXX km/h														
VHCL/S SE-MTR	XXX km/h														
THRTL POS SEN	XXX V														
FLUID TEMP SE	XXX V														
BATTERY VOLT	XXX V														
OK or NG															
OK ▶	GO TO 4.														
NG ▶	Check harness for short or open between ECM and TCM regarding throttle position sensor circuit. (Main harness)														

SAT014K

SAT614J

DTC P1705 THROTTLE POSITION SENSOR

Diagnostic Procedure (Cont'd)

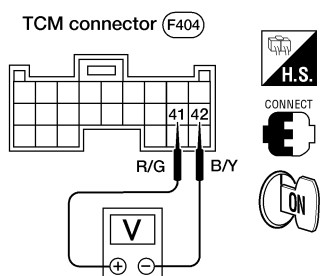
3	CHECK INPUT SIGNAL (Without CONSULT-II)	
<p>⊗ Without CONSULT-II</p> <p>1. Turn ignition switch to ON position. (Do not start engine.)</p> <p>2. Check voltage between TCM terminals 41 and 42 while accelerator pedal is depressed slowly.</p>		
		
AAT382A		
<p>Voltage:</p> <p>Fully-closed throttle valve: Approximately 0.5V</p> <p>Fully-open throttle valve: Approximately 4V</p> <p>(Voltage rises gradually in response to throttle position)</p> <p style="text-align: center;">OK or NG</p>		
OK	▶	GO TO 5.
NG	▶	Check harness for short or open between ECM and TCM regarding throttle position sensor circuit. (Main harness)

GI
MA
EM
LC
EC
FE
AT

4	CHECK THROTTLE POSITION SWITCH CIRCUIT (With CONSULT-II)															
<p>Ⓟ With CONSULT-II</p> <p>1. Turn ignition switch to ON position. (Do not start engine.)</p> <p>2. Select "TCM INPUT SIGNALS" in "DATA MONITOR" mode for "A/T" with CONSULT-II.</p> <p>3. Read out "CLOSED THL/SW" and "W/O THRL/P-SW" depressing and releasing accelerator pedal. Check the signal of throttle position switch is indicated properly.</p>																
<table border="1" style="margin: auto;"> <thead> <tr> <th rowspan="2">Accelerator pedal condition</th> <th colspan="2">Data monitor</th> </tr> <tr> <th>CLOSED THL/SW</th> <th>W/O THRL/P-SW</th> </tr> </thead> <tbody> <tr> <td>Released</td> <td>ON</td> <td>OFF</td> </tr> <tr> <td>Fully depressed</td> <td>OFF</td> <td>ON</td> </tr> </tbody> </table>			Accelerator pedal condition	Data monitor		CLOSED THL/SW	W/O THRL/P-SW	Released	ON	OFF	Fully depressed	OFF	ON			
Accelerator pedal condition	Data monitor															
	CLOSED THL/SW	W/O THRL/P-SW														
Released	ON	OFF														
Fully depressed	OFF	ON														
<table border="1" style="margin: auto;"> <thead> <tr> <th colspan="2">DATA MONITOR</th> </tr> <tr> <th>MONITORING</th> <th></th> </tr> </thead> <tbody> <tr> <td>POWERSHIFT SW</td> <td>OFF</td> </tr> <tr> <td>CLOSED THL/SW</td> <td>OFF</td> </tr> <tr> <td>W/O THRL/P-SW</td> <td>OFF</td> </tr> <tr> <td>HOLD SW</td> <td>OFF</td> </tr> <tr> <td>BRAKE SW</td> <td>ON</td> </tr> </tbody> </table>			DATA MONITOR		MONITORING		POWERSHIFT SW	OFF	CLOSED THL/SW	OFF	W/O THRL/P-SW	OFF	HOLD SW	OFF	BRAKE SW	ON
DATA MONITOR																
MONITORING																
POWERSHIFT SW	OFF															
CLOSED THL/SW	OFF															
W/O THRL/P-SW	OFF															
HOLD SW	OFF															
BRAKE SW	ON															
MTBL0011																
OK or NG																
OK	▶	GO TO 6.														
NG	▶	<p>Check the following items:</p> <ul style="list-style-type: none"> ● Throttle position switch — Refer to "Component Inspection", AT-191. ● Harness for short or open between ignition switch and throttle position switch (Main harness) ● Harness for short or open between throttle position switch and TCM (Main harness) 														
SAT702J																

BR
ST
RS
BT
HA
SC
EL
IDX

DTC P1705 THROTTLE POSITION SENSOR

Diagnostic Procedure (Cont'd)

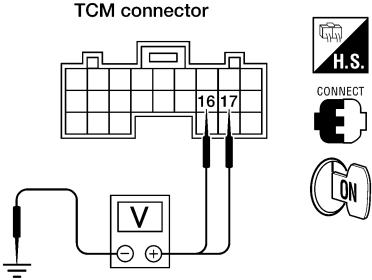
5	CHECK THROTTLE POSITION SWITCH CIRCUIT (Without CONSULT-II)	
<p>⊗ Without CONSULT-II</p> <ol style="list-style-type: none"> Turn ignition switch to ON position. (Do not start engine.) Check voltage between TCM harness connector F403 terminals 16 (BR/Y), 17 (R/W) and ground while depressing, and releasing accelerator pedal slowly. (After warming up engine) 		
		
LAT384		
OK or NG		
OK	▶	GO TO 6.
NG	▶	<p>Check the following items:</p> <ul style="list-style-type: none"> Throttle position switch — Refer to “Component Inspection”, AT-191. Harness for short or open between ignition switch and throttle position switch (Main harness) Harness for short or open between throttle position switch and TCM (Main harness)

6	CHECK DTC	
Perform Diagnostic Trouble Code (DTC) confirmation procedure, AT-186.		
OK or NG		
OK	▶	INSPECTION END
NG	▶	<ol style="list-style-type: none"> Perform TCM input/output signal inspection. If NG, recheck TCM pin terminals for damage or loose connection with harness connector.

DTC P1705 THROTTLE POSITION SENSOR

Component Inspection

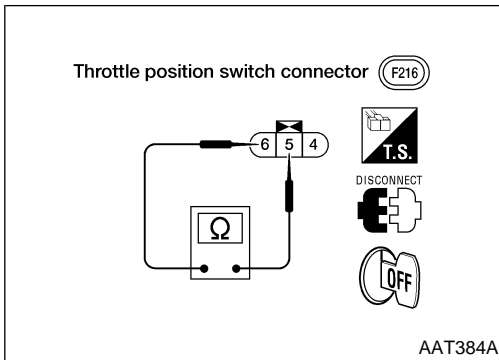

Component Inspection

THROTTLE POSITION SWITCH

=NDAT0075

NDAT0075S01

NDAT0075S0101

Closed Throttle Position Switch (Idle position)

- Check continuity between terminals 5 and 6.

Accelerator pedal condition	Continuity
Released	Yes
Depressed	No

- To adjust closed throttle position switch, refer to "Basic Inspection", **EC-87**.

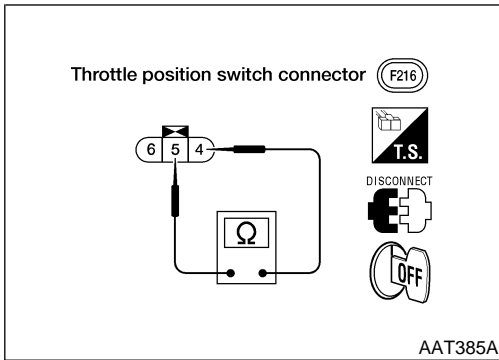

Wide Open Throttle Position Switch

NDAT0075S0102

- Check continuity between terminals 4 and 5.

Accelerator pedal condition	Continuity
Released	No
Depressed	Yes

GI

MA

EM

LC

EC

FE

AT

AX

SU

BR

ST

RS

BT

HA

SC

EL

IDX

DTC P1760 OVERRUN CLUTCH SOLENOID VALVE

Description

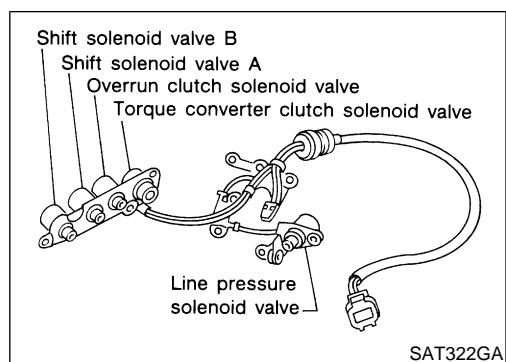

Description

The overrun clutch solenoid valve is activated by the TCM^{NDAT0076} in response to signals sent from the park/neutral position (PNP) switch, overdrive control switch, vehicle speed and throttle position sensors. The overrun clutch operation will then be controlled.

TCM TERMINALS AND REFERENCE VALUE



NDAT0076S01

Remarks: Specification data are reference values.

Terminal No.	Wire color	Item	Condition	Judgement standard (Approx.)
20	OR/B	Overrun clutch solenoid valve	 When overrun clutch solenoid valve operates.	Battery voltage
			When overrun clutch solenoid valve does not operate.	0V

ON BOARD DIAGNOSIS LOGIC

NDAT0076S02

Diagnostic trouble code	Malfunction is detected when ...	Check items (Possible cause)
 : O/R CLTCH SOL/CIRC	TCM detects an improper voltage drop when it tries to operate the solenoid valve.	<ul style="list-style-type: none"> ● Harness or connectors (The solenoid circuit is open or shorted.) ● Overrun clutch solenoid valve
 : P1760		
 : MIL Code No. 1203		

DTC P1760 OVERRUN CLUTCH SOLENOID VALVE

Description (Cont'd)

SELECT SYSTEM
A/T
ENGINE

SAT014K

SELECT DIAG MODE
WORK SUPPORT
SELF-DIAG RESULTS
DATA MONITOR
DATA MONITOR (SPEC)
ACTIVE TEST
DTC & SRT CONFIRMATION

SEF949Y

DIAGNOSTIC TROUBLE CODE (DTC) CONFIRMATION PROCEDURE

=NDAT0076S03

CAUTION:

Always drive vehicle at a safe speed.

NOTE:

If "DIAGNOSTIC TROUBLE CODE CONFIRMATION PROCEDURE" has been previously conducted, always turn ignition switch OFF and wait at least 5 seconds before conducting the next test.

TESTING CONDITION:

Always drive vehicle on a level road to improve accuracy of test.

After the repair, perform the following procedure to confirm the malfunction is eliminated.

Ⓜ With CONSULT-II

- 1) Turn ignition switch ON and select "DATA MONITOR" mode for "ENGINE" with CONSULT-II.
- 2) Start engine.
- 3) Accelerate vehicle to a speed of more than 10 km/h (6 MPH) with D position (O/D ON).
- 4) Release accelerator pedal completely with D position (O/D OFF).

Ⓜ With GST

Follow the procedure "With CONSULT-II".

GI

MA

EM

LC

EC

FE

AT

AX

SU

BR

ST

RS

BT

HA

SC

EL

IDX

DTC P1760 OVERRUN CLUTCH SOLENOID VALVE

Wiring Diagram — AT — OVRCSV

Wiring Diagram — AT — OVRCSV

NDAT0211

AT-OVRCSV-01

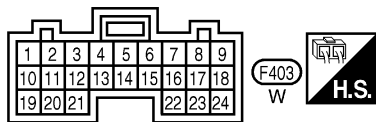
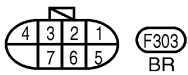
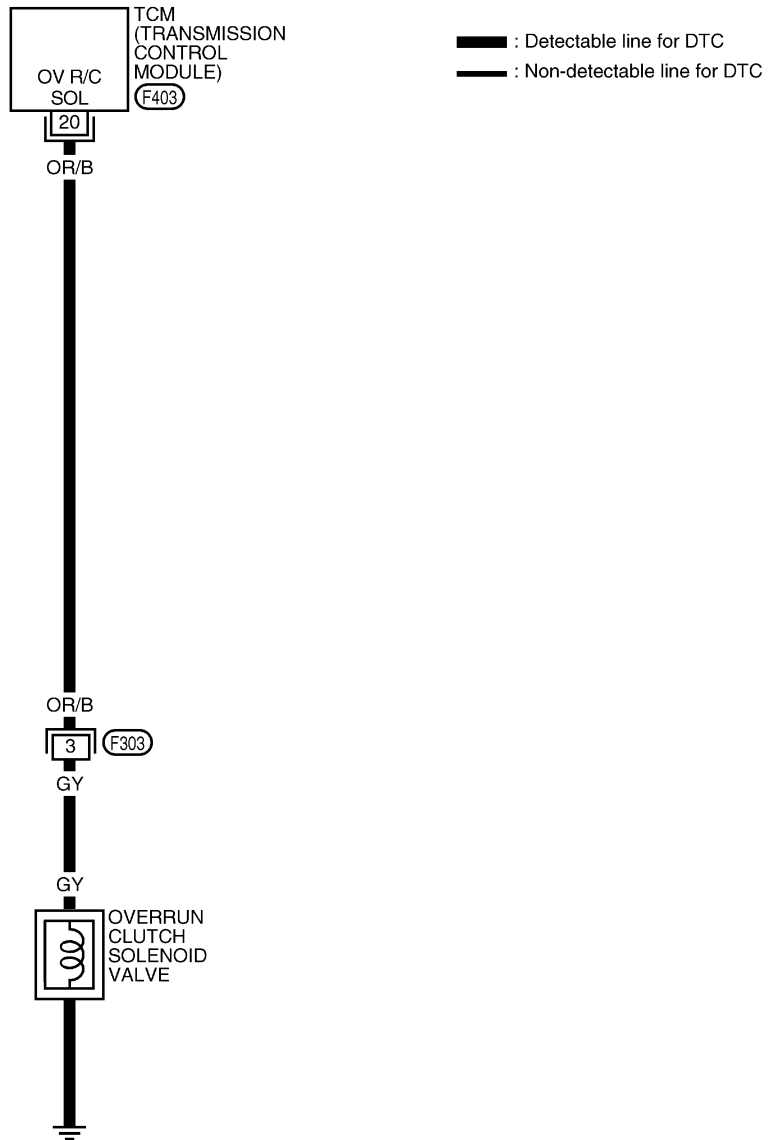

AAT272A

DTC P1760 OVERRUN CLUTCH SOLENOID VALVE

Diagnostic Procedure

Diagnostic Procedure

NDAT0077

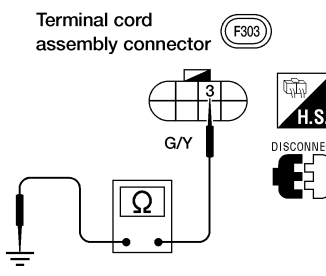
1	CHECK VALVE RESISTANCE	
<p>1. Turn ignition switch to OFF position. 2. Disconnect terminal cord assembly connector in engine compartment. 3. Check resistance between terminal 3 and ground.</p> <div style="text-align: center;">  </div> <p>Resistance: 20 - 40Ω</p> <p style="text-align: right;">AAT386A</p> <p style="text-align: center;">OK or NG</p>		
OK	▶	GO TO 2.
NG	▶	<p>1. Remove control valve assembly. Refer to “Control Valve Assembly and Accumulators”, AT-270.</p> <p>2. Check the following items:</p> <ul style="list-style-type: none"> ● Overrun clutch solenoid valve Refer to “Component Inspection”, AT-197. ● Harness of terminal cord assembly for short or open

GI
MA
EM
LC
EC
FE
AT
AX
SU
BR
ST
RS
BT
HA
SC
EL
IDX

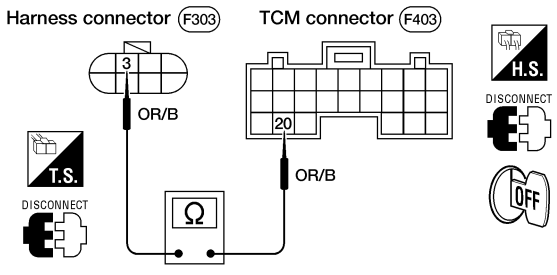
2	CHECK POWER SOURCE CIRCUIT	
<p>1. Turn ignition switch to OFF position. 2. Disconnect TCM harness connector. 3. Check continuity between terminal 3 and TCM harness connector terminal 20.</p> <div style="text-align: center;">  </div> <p>If OK, check harness for short to ground and short to power. Continuity should exist.</p> <p>4. Reinstall any part removed.</p> <p style="text-align: right;">AAT387A</p> <p style="text-align: center;">OK or NG</p>		
OK	▶	GO TO 3.
NG	▶	Repair open circuit or short to ground or short to power in harness or connectors.

DTC P1760 OVERRUN CLUTCH SOLENOID VALVE

Diagnostic Procedure (Cont'd)

3	CHECK DTC
Perform "DIAGNOSTIC TROUBLE CODE (DTC) CONFIRMATION PROCEDURE", AT-193.	
OK or NG	
OK	▶ INSPECTION END
NG	▶ 1. Perform TCM input/output signal inspection. 2. If NG, recheck TCM pin terminals for damage or loose connection with harness connector.

DTC P1760 OVERRUN CLUTCH SOLENOID VALVE

Component Inspection

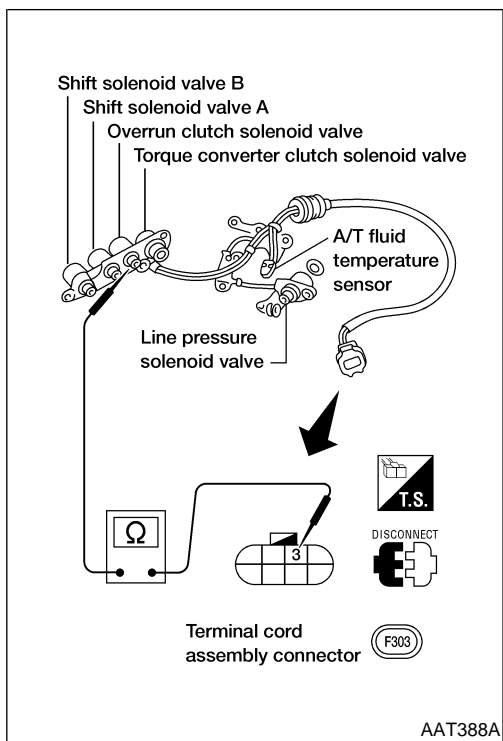

Component Inspection

=NDAT0078

OVERRUN CLUTCH SOLENOID VALVE

NDAT0078S01

- For removal, refer to "Control Valve Assembly and Accumulators", AT-270.

Resistance Check

NDAT0078S0101

- Check resistance between two terminals.

Solenoid valve	Terminal No.		Resistance (Approx.)
Overrun clutch solenoid valve	3	Ground	20 - 40Ω

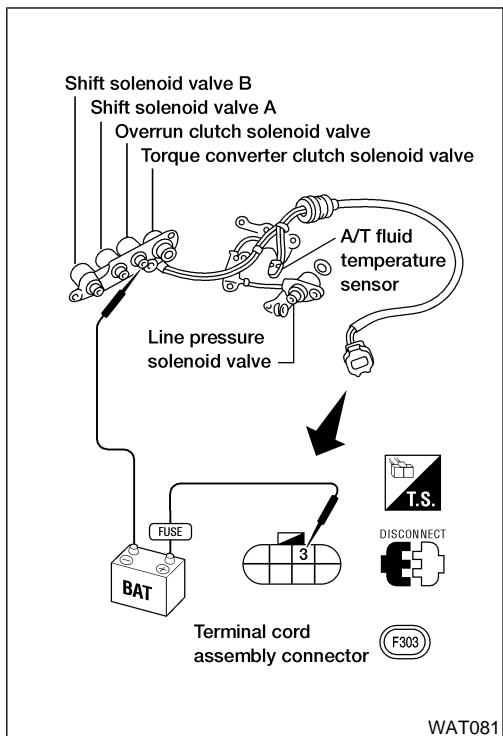

Operation Check

NDAT0078S0102

- Check solenoid valve by listening for its operating sound while applying battery voltage to the terminal and ground.

GI

MA

EM

LC

EC

FE

AT

AX

SU

BR

ST

RS

BT

HA

SC

EL

IDX

DTC BATT/FLUID TEMP SEN (A/T FLUID TEMP SENSOR CIRCUIT AND TCM POWER SOURCE)

Description

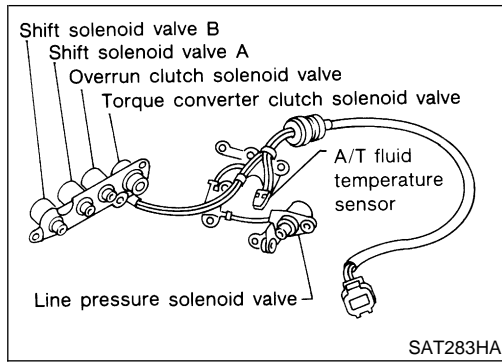

Description

The A/T fluid temperature sensor detects the A/T fluid temperature and sends a signal to the TCM. NDAT0079

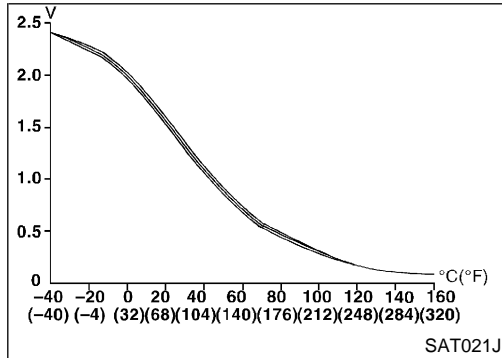

CONSULT-II REFERENCE VALUE IN DATA MONITOR MODE

Remarks: Specification data are reference values.

NDAT0079S01

Monitor item	Condition	Specification (Approx.)	
A/T fluid temperature sensor	Cold [20°C (68°F)]	1.5V	2.5k Ω
	Hot [80°C (176°F)]	0.5V	0.3k Ω

TCM TERMINALS AND REFERENCE VALUE

Remarks: Specification data are reference values.

NDAT0079S02

Terminal No.	Wire color	Item	Condition	Judgement standard (Approx.)	
10	LG	Power source		When turning ignition switch to ON.	Battery voltage
				When turning ignition switch to OFF.	0V
19	LG	Power source	or	Same as No. 10	
28	PU	Power source (Memory back-up)		When turning ignition switch to OFF.	Battery voltage
				When turning ignition switch to ON.	Battery voltage
42	B/Y	Throttle position sensor (Ground)		—	
47	SB	A/T fluid temperature sensor		When ATF temperature is 20°C (68°F).	1.5V
				When ATF temperature is 80°C (176°F).	0.5V

DTC BATT/FLUID TEMP SEN (A/T FLUID TEMP SENSOR CIRCUIT AND TCM POWER SOURCE)

Description (Cont'd)

ON BOARD DIAGNOSIS LOGIC

NDAT0079S03

Diagnostic trouble code	Malfunction is detected when ...	Check items (Possible cause)
: BATT/FLUID TEMP SEN : 8th judgement flicker	TCM receives an excessively low or high voltage from the sensor.	<ul style="list-style-type: none"> • Harness or connectors (The sensor circuit is open or shorted.) • A/T fluid temperature sensor

GI

MA

EM

LC

EC

FE

AT

AX

SU

BR

ST

RS

BT

HA

SC

EL

IDX

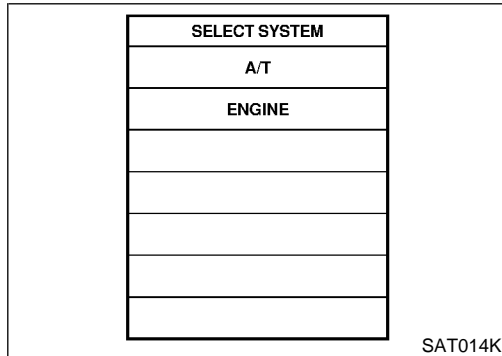

DIAGNOSTIC TROUBLE CODE (DTC) CONFIRMATION PROCEDURE

NDAT0079S04

After the repair, perform the following procedure to confirm the malfunction is eliminated.

With CONSULT-II

- 1) Start engine.
- 2) Select "DATA MONITOR" mode for "A/T" with CONSULT-II.
- 3) Drive vehicle under the following conditions:
Selector lever in D, vehicle speed higher than 20 km/h (12 MPH).

Without CONSULT-II

- 1) Start engine.
- 2) Drive vehicle under the following conditions:
Selector lever in D, vehicle speed higher than 20 km/h (12 MPH).
- 3) Perform self-diagnosis.
Refer to "TCM SELF-DIAGNOSTIC PROCEDURE (NO TOOLS)", AT-48.

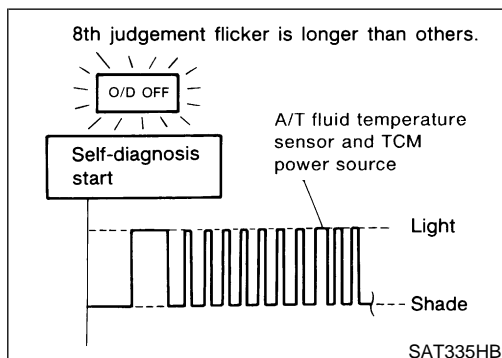
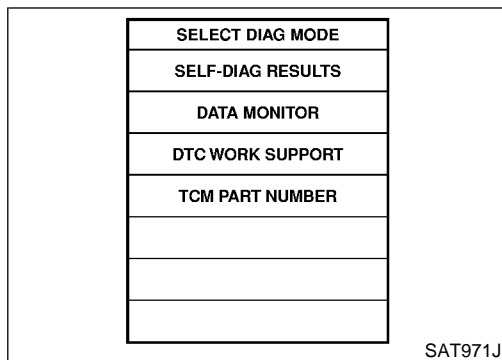

DTC BATT/FLUID TEMP SEN (A/T FLUID TEMP SENSOR CIRCUIT AND TCM POWER SOURCE)

Wiring Diagram — AT — BA/FTS

Wiring Diagram — AT — BA/FTS

NDAT0212

AT-BA/FTS-01

— : Detectable line for DTC
— : Non-detectable line for DTC

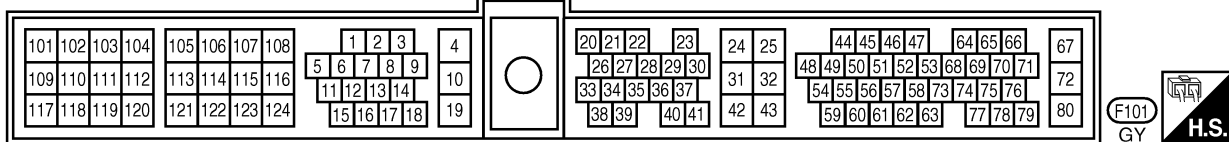
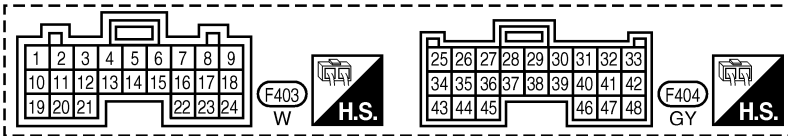
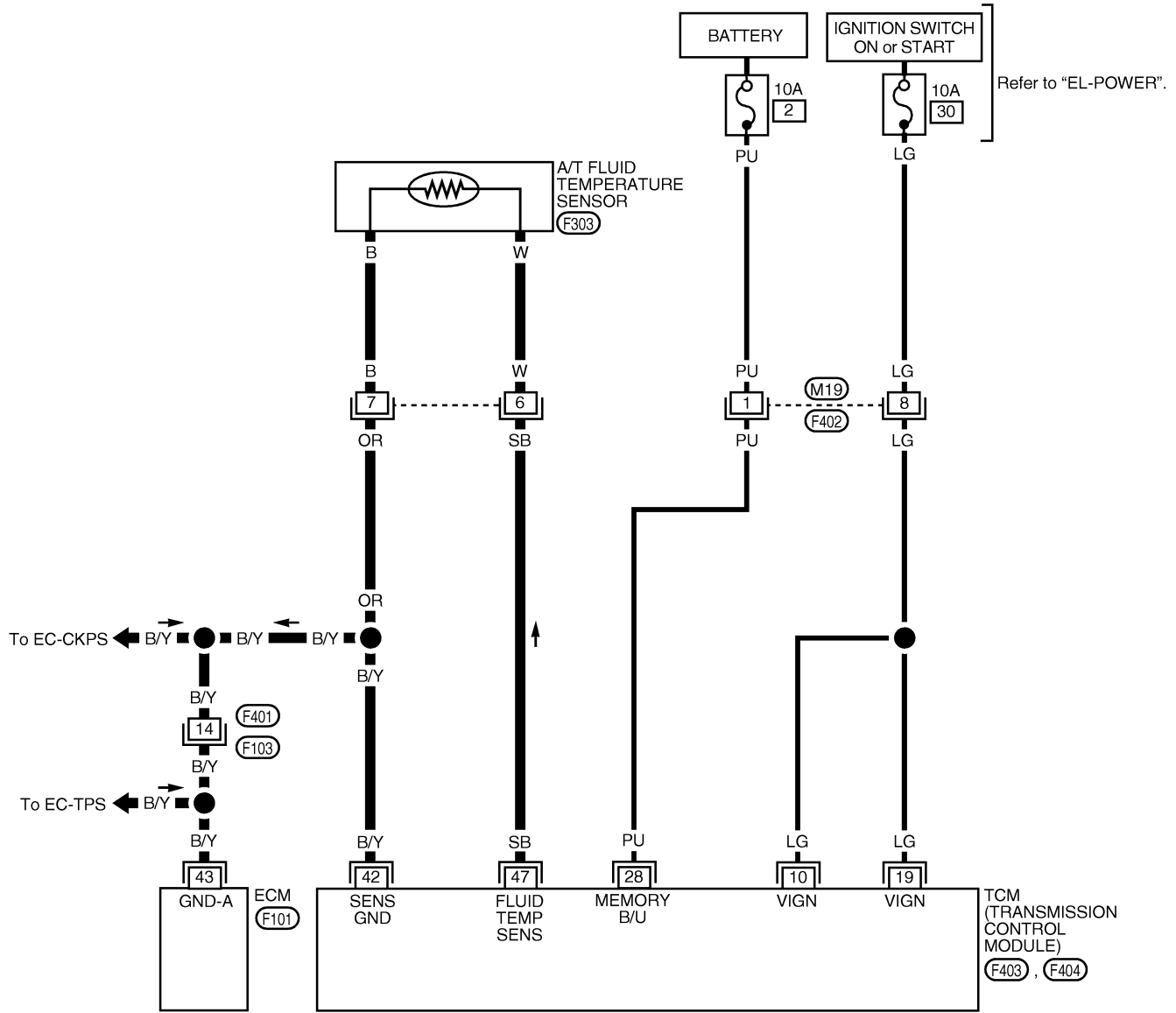

WAT061

DTC BATT/FLUID TEMP SEN (A/T FLUID TEMP SENSOR CIRCUIT AND TCM POWER SOURCE)

Diagnostic Procedure

Diagnostic Procedure

NDAT0080

1	CHECK TCM POWER SOURCE		GI MA EM LC EC FE AT AX SU BR
		<p>1. Turn ignition switch to ON position. (Do not start engine.)</p> <p>2. Check voltage between TCM terminals 10, 19, 28 and ground.</p> <p style="margin-left: 20px;">Voltage: Battery voltage</p> <p>3. Turn ignition switch to OFF position.</p> <p>4. Check voltage between TCM terminal 28 and ground.</p> <div style="text-align: center;"> </div> <p style="text-align: right;">AAT347A</p>	
		OK or NG	
OK	▶	GO TO 2.	
NG	▶	<p>Check the following items:</p> <ul style="list-style-type: none"> ● Harness for short or open between ignition switch and TCM (Main harness) ● Ignition switch and fuse <p>Refer to EL-10, "POWER SUPPLY ROUTING".</p>	

2	CHECK A/T FLUID TEMPERATURE SENSOR WITH TERMINAL CORD ASSEMBLY		ST RS BT HA SC EL IDX
		<p>1. Turn ignition switch to OFF position.</p> <p>2. Disconnect terminal cord assembly connector in engine compartment.</p> <p>3. Check resistance between terminals 6 and 7 when A/T is cold.</p> <div style="text-align: center;"> </div> <p style="text-align: right;">AAT390A</p>	
		OK or NG	
OK (with CONSULT-II)	▶	GO TO 3.	
OK (without CONSULT-II)	▶	GO TO 4.	
NG	▶	<p>1. Remove oil pan.</p> <p>2. Check the following items:</p> <ul style="list-style-type: none"> ● A/T fluid temperature sensor <p>Refer to "Component Inspection", AT-204.</p> <ul style="list-style-type: none"> ● Harness of terminal cord assembly for short or open 	

DTC BATT/FLUID TEMP SEN (A/T FLUID TEMP SENSOR CIRCUIT AND TCM POWER SOURCE)

Diagnostic Procedure (Cont'd)

3	CHECK INPUT SIGNAL OF A/T FLUID TEMPERATURE SENSOR (With CONSULT-II)															
<p>Ⓜ With CONSULT-II</p> <ol style="list-style-type: none"> 1. Start engine. 2. Select "TCM INPUT SIGNALS" in "DATA MONITOR" mode for "A/T" with CONSULT-II. 3. Read out the value of "FLUID TEMP SE". 																
<table border="1" style="margin: auto; border-collapse: collapse;"> <thead> <tr> <th colspan="2" style="padding: 2px;">DATA MONITOR</th> </tr> <tr> <th style="padding: 2px;">MONITORING</th> <th style="padding: 2px;"></th> </tr> </thead> <tbody> <tr> <td style="padding: 2px;">VHCL/S SE-A/T</td> <td style="padding: 2px;">XXX km/h</td> </tr> <tr> <td style="padding: 2px;">VHCL/S SE-MTR</td> <td style="padding: 2px;">XXX km/h</td> </tr> <tr> <td style="padding: 2px;">THRTL POS SEN</td> <td style="padding: 2px;">XXX V</td> </tr> <tr> <td style="padding: 2px;">FLUID TEMP SE</td> <td style="padding: 2px;">XXX V</td> </tr> <tr> <td style="padding: 2px;">BATTERY VOLT</td> <td style="padding: 2px;">XXX V</td> </tr> </tbody> </table>			DATA MONITOR		MONITORING		VHCL/S SE-A/T	XXX km/h	VHCL/S SE-MTR	XXX km/h	THRTL POS SEN	XXX V	FLUID TEMP SE	XXX V	BATTERY VOLT	XXX V
DATA MONITOR																
MONITORING																
VHCL/S SE-A/T	XXX km/h															
VHCL/S SE-MTR	XXX km/h															
THRTL POS SEN	XXX V															
FLUID TEMP SE	XXX V															
BATTERY VOLT	XXX V															
SAT614J																
<p>Voltage: Cold [20°C (68°F)] → Hot [80°C (176°F)]: Approximately 1.5V → 0.5V</p>																
OK or NG																
OK	▶	GO TO 5.														
NG	▶	<p>Check the following item:</p> <ul style="list-style-type: none"> ● Harness for short or open between TCM, ECM and terminal cord assembly (Main harness) ● Ground circuit for ECM <p>Refer to EC-121, "TROUBLE DIAGNOSIS FOR POWER SUPPLY".</p>														

DTC BATT/FLUID TEMP SEN (A/T FLUID TEMP SENSOR CIRCUIT AND TCM POWER SOURCE)

Diagnostic Procedure (Cont'd)

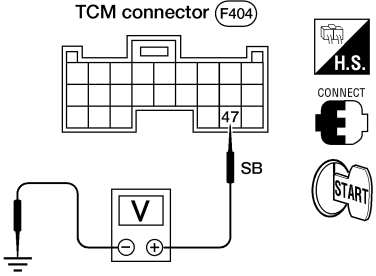
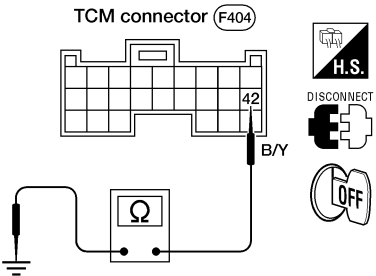
4	CHECK INPUT SIGNAL OF A/T FLUID TEMPERATURE SENSOR (Without CONSULT-II)	
<p>⊗ Without CONSULT-II</p> <ol style="list-style-type: none"> Start engine. Check voltage between TCM terminal 47 and ground while warming up A/T. <div style="display: flex; justify-content: space-around; align-items: center;">  <div style="text-align: right;"> <p>AAT391A</p> </div> </div> <p>Voltage: Cold [20°C (68°F)] → Hot [80°C (176°F)]: Approximately 1.5V → 0.5V</p> <ol style="list-style-type: none"> Turn ignition switch to OFF position. Disconnect TCM harness connector. Check resistance between terminal 42 and ground. <div style="display: flex; justify-content: space-around; align-items: center;">  <div style="text-align: right;"> <p>AAT392A</p> </div> </div> <p>Continuity should exist.</p> <p style="text-align: center;">OK or NG</p>		
OK	▶	GO TO 5.
NG	▶	<p>Check the following item:</p> <ul style="list-style-type: none"> Harness for short or open between TCM, ECM and terminal cord assembly (Main harness) Ground circuit for ECM <p>Refer to EC-121, "TROUBLE DIAGNOSIS FOR POWER SUPPLY".</p>

5	CHECK DTC	
<p>Perform "DIAGNOSTIC TROUBLE CODE (DTC) CONFIRMATION PROCEDURE", AT-199.</p> <p style="text-align: center;">OK or NG</p>		
OK	▶	INSPECTION END
NG	▶	<ol style="list-style-type: none"> Perform TCM input/output signal inspection. If NG, recheck TCM pin terminals for damage or loose connection with harness connector.

GI
MA
EM
LC
EC
FE
AT
AX
SU
BR
ST
RS
BT
HA
SC
EL
IDX

DTC BATT/FLUID TEMP SEN (A/T FLUID TEMP SENSOR CIRCUIT AND TCM POWER SOURCE)

Component Inspection

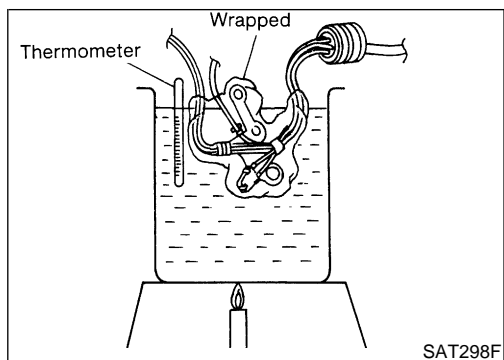

Component Inspection

A/T FLUID TEMPERATURE SENSOR

=NDAT0081

NDAT0081S01

- For removal, refer to "Control Valve Assembly and Accumulators", AT-270.
- Check resistance between two terminals while changing temperature as shown at left.

Temperature °C (°F)	Resistance (Approx.)
20 (68)	2.5 kΩ
80 (176)	0.3 kΩ

DTC VEHICLE SPEED SENSOR-MTR

Description

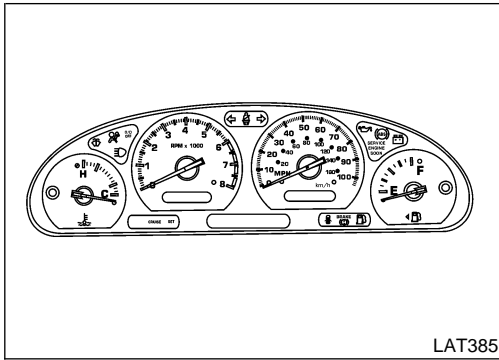

Description

The vehicle speed sensor-MTR is built into the speedometer assembly. The sensor functions as an auxiliary device to the revolution sensor when it is malfunctioning. The TCM will then use a signal sent from the vehicle speed sensor-MTR.

NDAT0082

GI

MA

EM

LC

TCM TERMINALS AND REFERENCE VALUE

NDAT0082S01

Remarks: Specification data are reference values.

Terminal No.	Wire color	Item	Condition	Judgement standard (Approx.)
40	G/Y	Vehicle speed sensor	 When moving vehicle at 2 to 3 km/h (1 to 2 MPH) for 1 m (3 ft) or more.	Voltage varies between less than 1V and more than 4.5V

EC



FE

AT

AX

ON BOARD DIAGNOSIS LOGIC

NDAT0082S02

Diagnostic trouble code	Malfunction is detected when ...	Check items (Possible cause)
 : VHCL SPEED SEN-MTR	TCM does not receive the proper voltage signal from the sensor.	<ul style="list-style-type: none"> • Harness or connectors (The sensor circuit is open or shorted.) • Vehicle speed sensor
 : 2nd judgement flicker		

SU

BR

ST

RS

BT

HA

SC

EL

IDX

DTC VEHICLE SPEED SENSOR-MTR

Description (Cont'd)

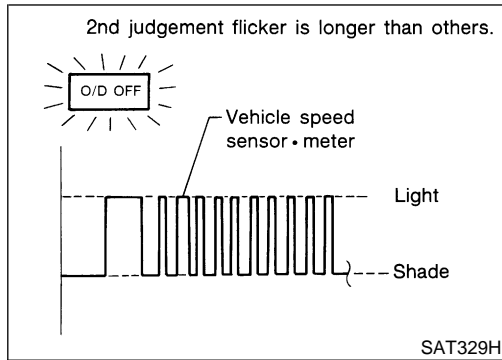
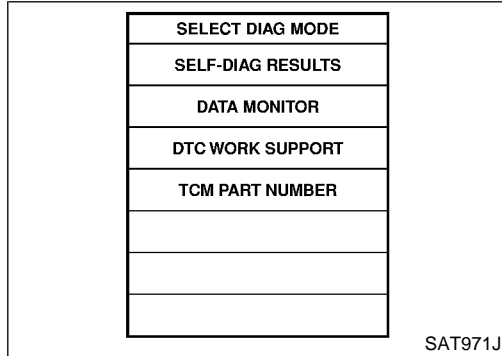
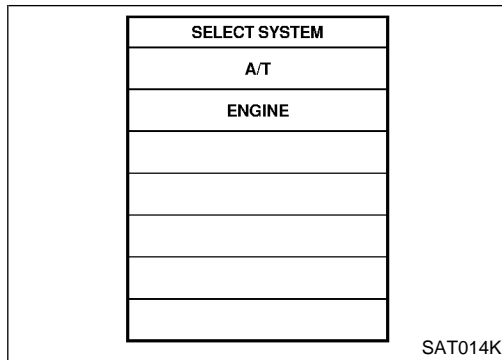

DIAGNOSTIC TROUBLE CODE (DTC) CONFIRMATION PROCEDURE

NDAT0082S03

CAUTION:

- Always drive vehicle at a safe speed.
- If conducting this “DTC CONFIRMATION PROCEDURE” again, always turn ignition switch OFF and wait at least 5 seconds before continuing.

After the repair, perform the following procedure to confirm the malfunction is eliminated.

④ With CONSULT-II

- 1) Turn ignition switch ON and select “DATA MONITOR” mode for “A/T” with CONSULT-II.
- 2) Start engine and accelerate vehicle from 0 to 25 km/h (0 to 16 MPH).

⊗ Without CONSULT-II

- 1) Start engine.
- 2) Drive vehicle under the following conditions:
Selector lever in D and vehicle speed higher than 25 km/h (16 MPH).
- 3) Perform self-diagnosis.
Refer to “TCM SELF-DIAGNOSTIC PROCEDURE (NO TOOLS)”, AT-48.

DTC VEHICLE SPEED SENSOR-MTR

Wiring Diagram — AT — VSSMTR

Wiring Diagram — AT — VSSMTR

NDAT0213

AT-VSSMTR-01

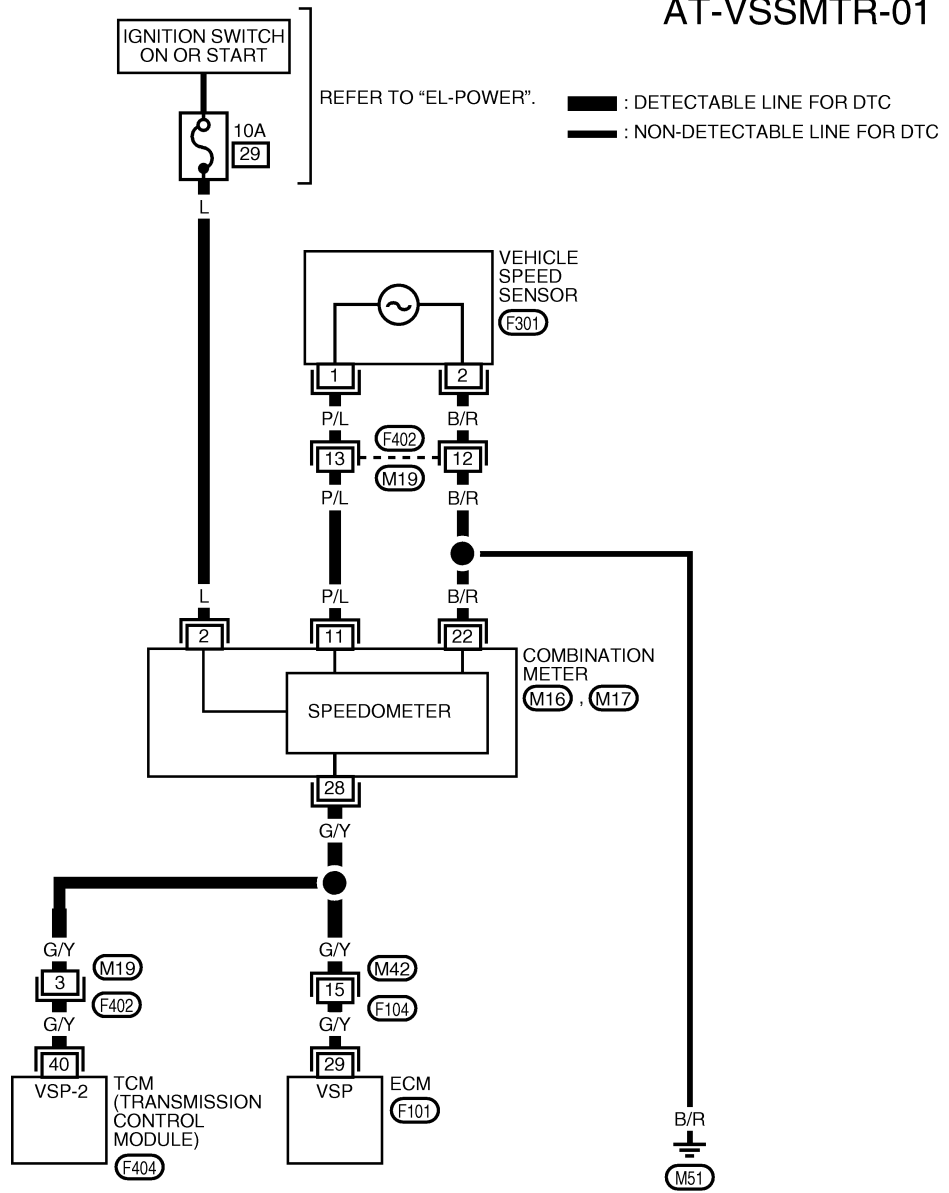

GI

MA

EM

LC

EC

FE

AT

AX

SU

BR

ST

RS

BT

HA

SC

EL

IDX

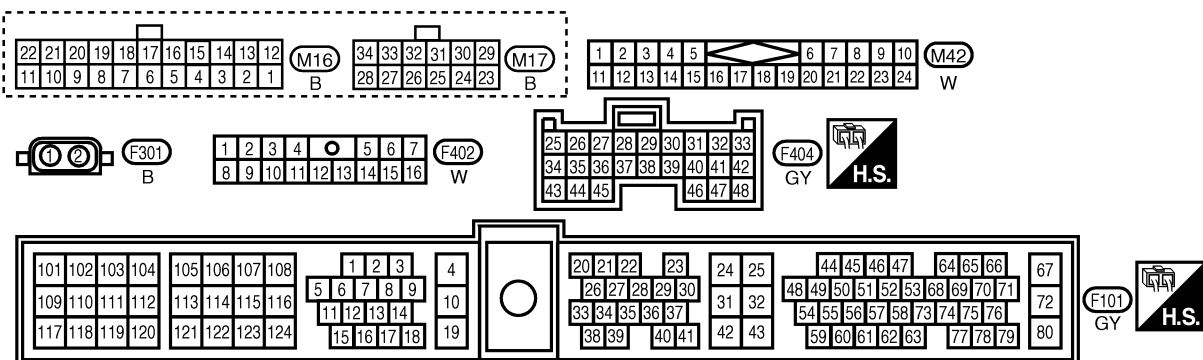



LAT324

DTC VEHICLE SPEED SENSOR-MTR

Diagnostic Procedure

Diagnostic Procedure

NDAT0083

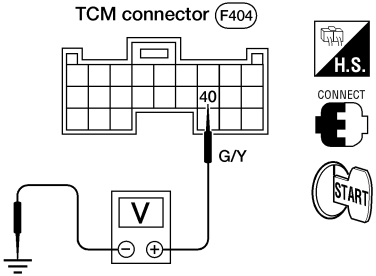
1	CHECK INPUT SIGNAL														
<p> With CONSULT-II</p> <ol style="list-style-type: none"> Start engine. Select "TCM INPUT SIGNAL" in "DATA MONITOR" mode for "A/T" with CONSULT-II. Read out the value of "VHCL/S SE-MTR" while driving. Check the value changes according to driving speed. 															
<table border="1"> <thead> <tr> <th colspan="2">DATA MONITOR</th> </tr> <tr> <th>MONITORING</th> <th></th> </tr> </thead> <tbody> <tr> <td>VHCL/S SE-A/T</td> <td>XXX km/h</td> </tr> <tr> <td>VHCL/S SE-MTR</td> <td>XXX km/h</td> </tr> <tr> <td>THRTL POS SEN</td> <td>XXX V</td> </tr> <tr> <td>FLUID TEMP SE</td> <td>XXX V</td> </tr> <tr> <td>BATTERY VOLT</td> <td>XXX V</td> </tr> </tbody> </table>		DATA MONITOR		MONITORING		VHCL/S SE-A/T	XXX km/h	VHCL/S SE-MTR	XXX km/h	THRTL POS SEN	XXX V	FLUID TEMP SE	XXX V	BATTERY VOLT	XXX V
DATA MONITOR															
MONITORING															
VHCL/S SE-A/T	XXX km/h														
VHCL/S SE-MTR	XXX km/h														
THRTL POS SEN	XXX V														
FLUID TEMP SE	XXX V														
BATTERY VOLT	XXX V														
SAT614J															
<p> Without CONSULT-II</p> <ol style="list-style-type: none"> Start engine. Check voltage between TCM terminal 40 and ground while driving at 2 to 3 km/h (1 to 2 MPH) for 1 m (3 ft) or more. 															
															
AAT393A															
<p>Voltage: Voltage varies between less than 1V and more than 4.5V.</p> <p style="text-align: center;">OK or NG</p>															
OK	▶ GO TO 2.														
NG	▶ Check the following items: <ul style="list-style-type: none"> Vehicle speed sensor and ground circuit for vehicle speed sensor Refer to EL-86, "METERS AND GAUGES". Harness for short or open between TCM and vehicle speed sensor (Main harness) 														

2	CHECK DTC
Perform "DIAGNOSTIC TROUBLE CODE (DTC) CONFIRMATION PROCEDURE", AT-206.	
OK or NG	
OK	▶ INSPECTION END
NG	▶ <ol style="list-style-type: none"> Perform TCM input/output signal inspection. If NG, recheck TCM pin terminals for damage or loose connection with harness connector.

CONTROL UNIT (RAM), CONTROL UNIT (ROM)

Description

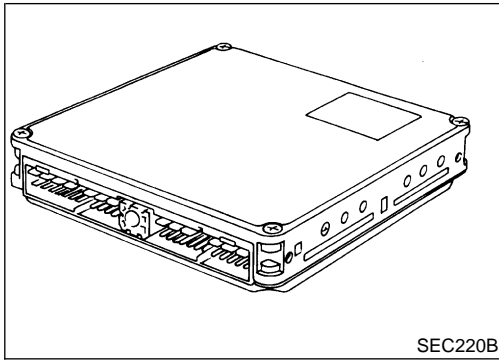

Description

The TCM consists of a microcomputer and connectors for signal ^{NDAT0226} input and output and for power supply. The unit controls the A/T.

GI

MA

EM

LC

On Board Diagnosis Logic

NDAT0227

Diagnostic trouble code	Malfunction is detected when ...	Check Item (Possible Cause)
ⓐ : CONTROL UNIT (RAM) ⓑ : CONTROL UNIT (ROM)	<ul style="list-style-type: none"> TCM memory (RAM) or (ROM) 	<ul style="list-style-type: none"> TCM

EC

FE

AT

AX

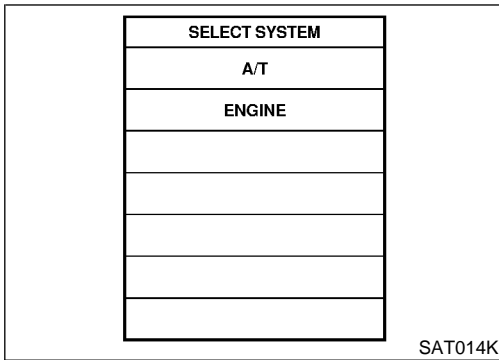

DTC Confirmation Procedure

NDAT0228

NOTE:

If "DTC Confirmation Procedure" has been previously conducted, always turn ignition switch OFF and wait at least 5 seconds before conducting the next test.

SU

BR

ⓐ With CONSULT-II

- 1) Turn ignition switch ON and select "DATA MONITOR" mode for A/T with CONSULT-II.
- 2) Start engine.
- 3) Run engine for at least 2 seconds at idle speed.

ST

RS

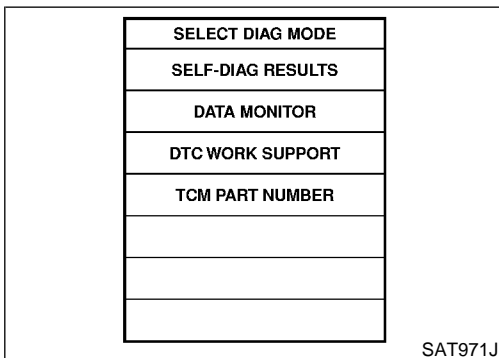

BT

HA

SC

EL

IDX

CONTROL UNIT (RAM), CONTROL UNIT (ROM)

Diagnostic Procedure

Diagnostic Procedure

NDAT0229

1	INSPECTION START
 With CONSULT-II 1. Turn ignition switch ON and select "SELF DIAGNOSIS" mode for A/T with CONSULT-II. 2. Touch "ERASE". 3. Perform "DIAGNOSTIC TROUBLE CODE (DTC) CONFIRMATION PROCEDURE". 4. Is the "CONTROL UNIT (RAM)" or "CONTROL UNIT (ROM)" displayed again?	
Yes or No	
Yes	▶ Replace TCM.
No	▶ INSPECTION END

CONTROL UNIT (EEP ROM)

Description

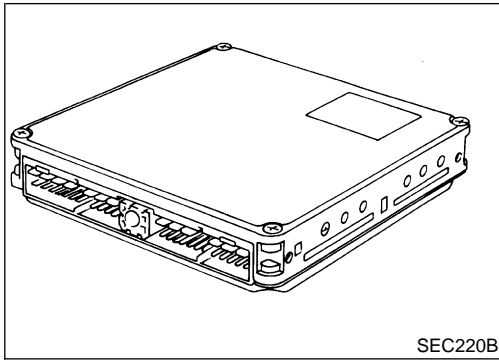

Description

The TCM consists of a microcomputer and connectors for signal input and output for power supply. The unit controls the A/T. ^{NDAT0217}

On Board Diagnosis Logic

NDAT0218

Diagnosis trouble code	Malfunction is detected when...	Check item (Possible cause)
Ⓜ : CONTROL UNIT (EEPROM)	TCM memory (EEPROM) is malfunctioning.	TCM

GI

MA

EM

LC

EC

FE

AT

AX

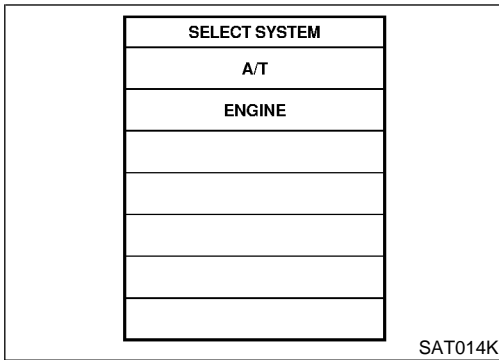

DTC Confirmation Procedure

NDAT0219

NOTE:

If "DIAGNOSTIC TROUBLE CODE CONFIRMATION PROCEDURE" has been previously conducted, always turn ignition switch "OFF" and wait at least 5 seconds before conducting the next test.

Ⓜ With CONSULT-II

- 1) Turn ignition switch "ON" and select "DATA MONITOR" mode for A/T with CONSULT-II.
- 2) Start engine.
- 3) Run engine for at least 2 seconds at idle speed.

SU

BR

ST

RS

BT

HA

SC

EL

IDX

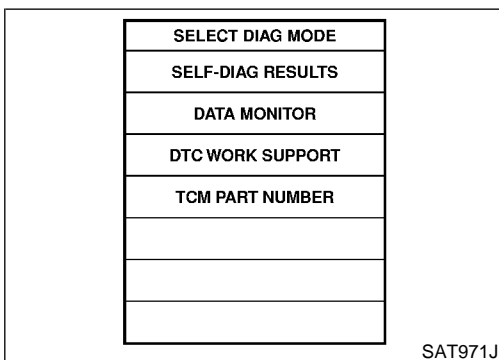



CONTROL UNIT (EEP ROM)

Diagnostic Procedure

Diagnostic Procedure

NDAT0220

1	CHECK DTC
<p> With CONSULT-II</p> <ol style="list-style-type: none">1. Turn ignition switch "ON" and select "SELF-DIAGNOSIS" mode for A/T with CONSULT-II.2. Move selector lever to "R" position.3. Depress accelerator pedal (Full throttle position).4. Touch "ERASE".5. Turn ignition switch to "OFF" position for 10 seconds. Perform DIAGNOSTIC TROUBLE CODE (DTC) CONFIRMATION PROCEDURE. See previous page.6. Is the "CONTROL UNIT (EEPROM)" displayed again? <p style="text-align: right;">Yes or No</p>	
Yes	 Replace TCM.
No	 INSPECTION END

TROUBLE DIAGNOSES FOR SYMPTOMS

Wiring Diagram — AT — NONDTC

Wiring Diagram — AT — NONDTC

NDAT0214

AT-NONDTC-01

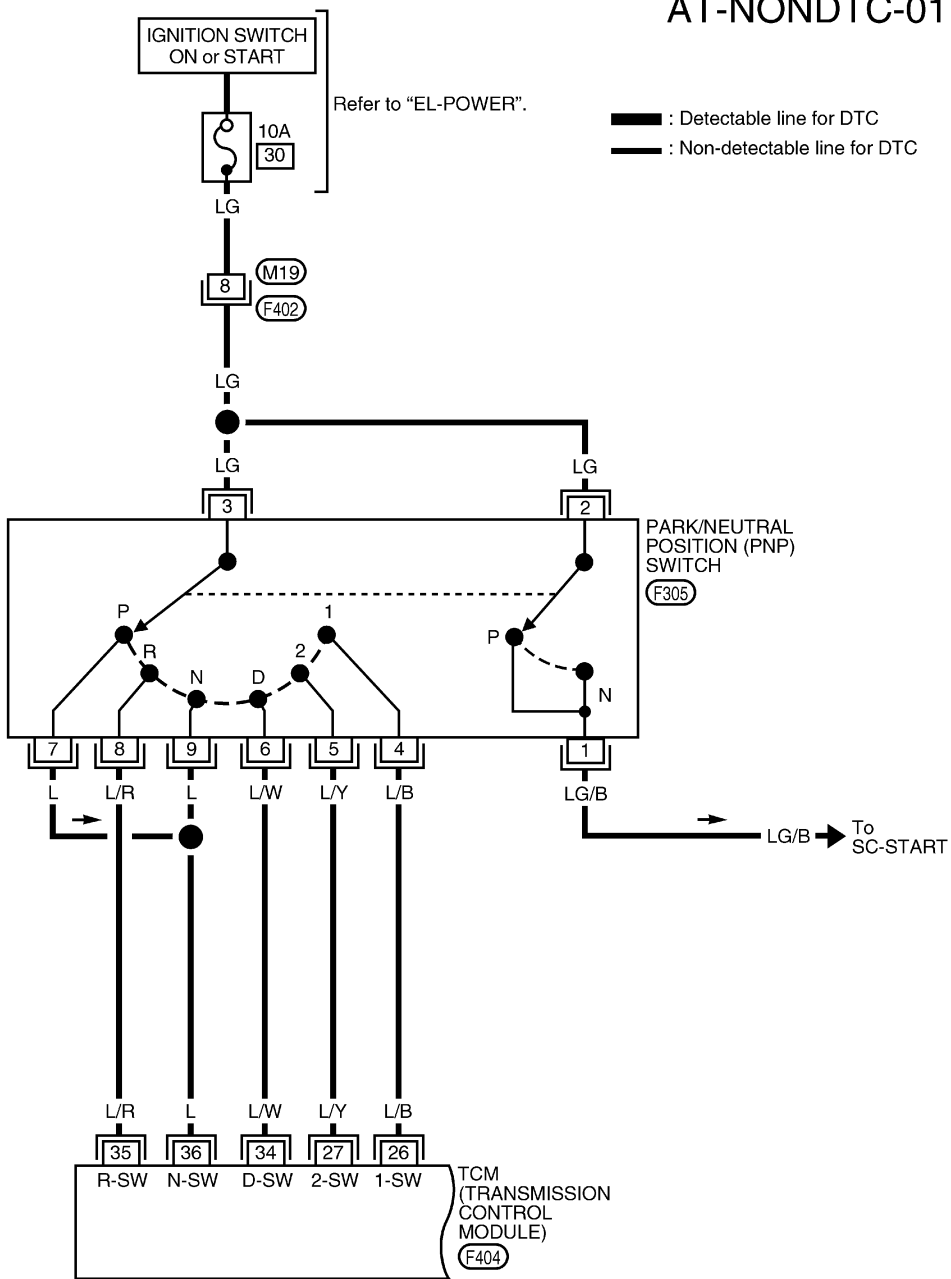

- GI
- MA
- EM
- LC
- EC
- FE
- AT**
- AX
- SU
- BR
- ST
- RS
- BT
- HA
- SC
- EL
- IDX

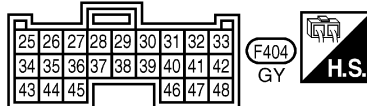
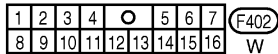
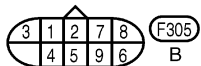

TROUBLE DIAGNOSES FOR SYMPTOMS

Wiring Diagram — AT — NONDTC (Cont'd)

AT-NONDTC-02

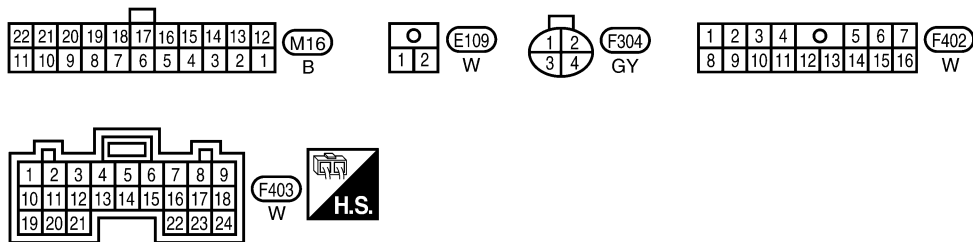
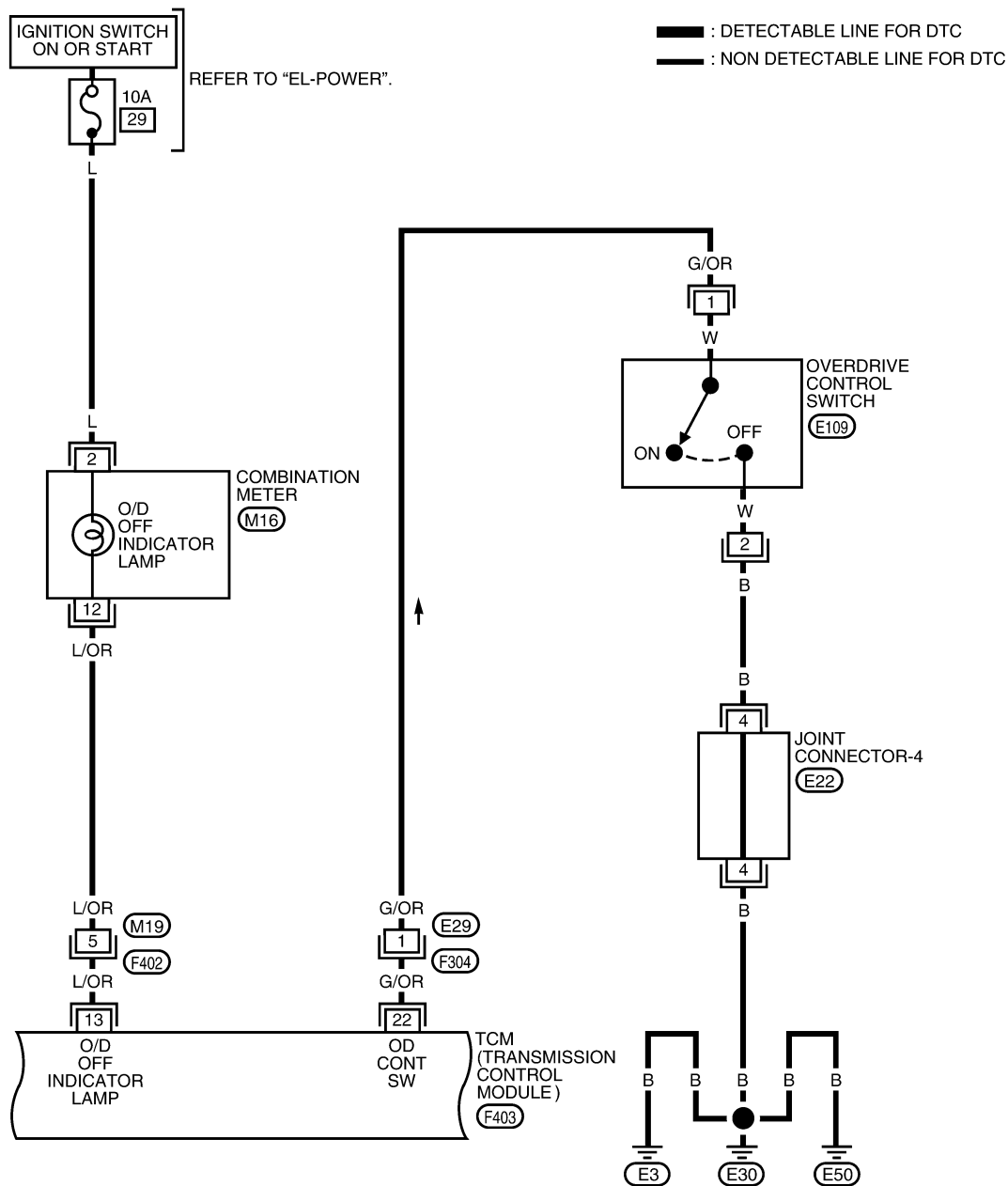

REFER TO THE FOLLOWING.
 (E22) - JOINT CONNECTOR

WAT325

TROUBLE DIAGNOSES FOR SYMPTOMS

Wiring Diagram — AT — NONDTC (Cont'd)

AT-NONDTC-03

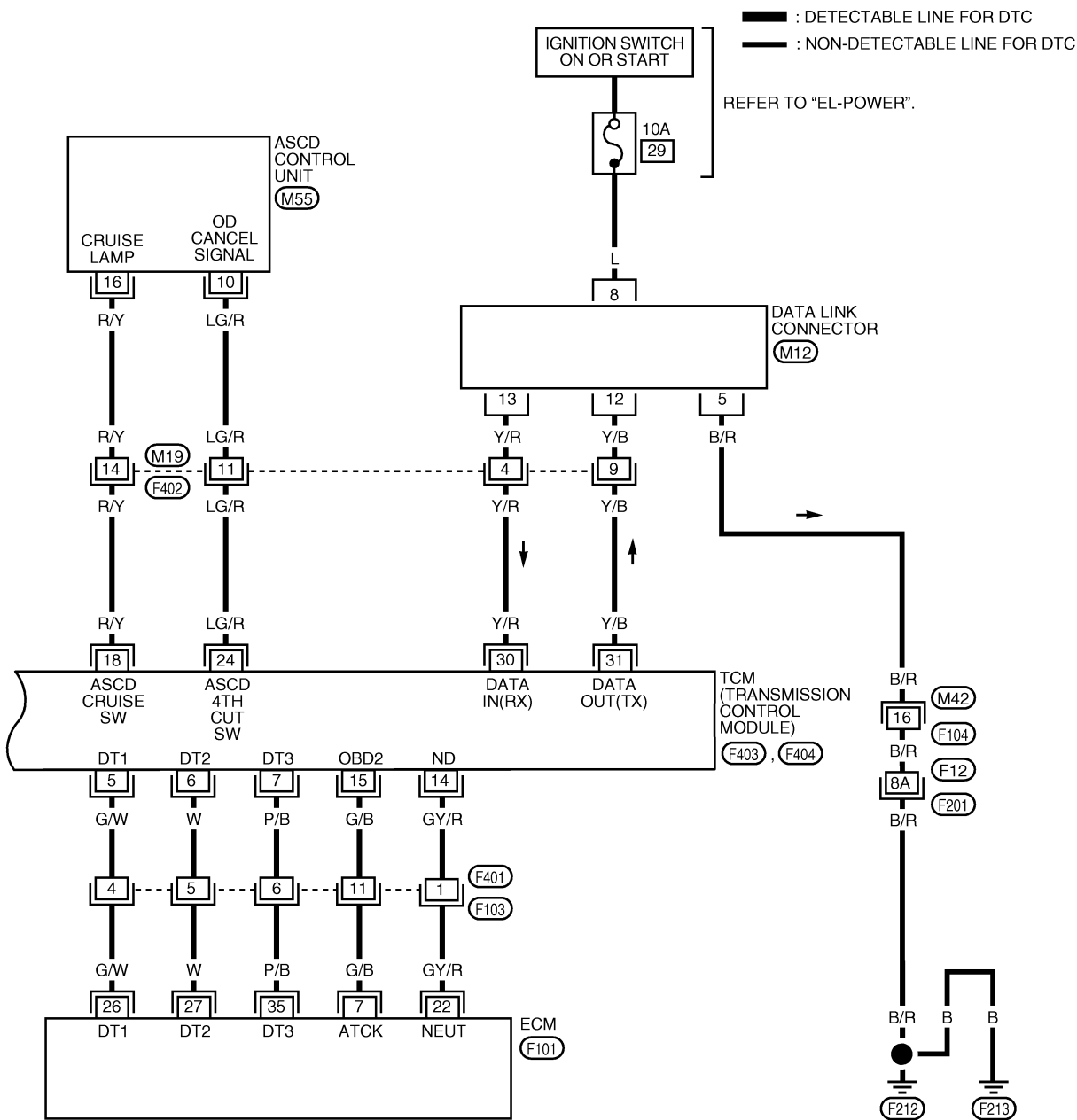

GI
MA
EM
LC
EC
FE
AT
AX
SU
BR
ST
RS
BT
HA
SC

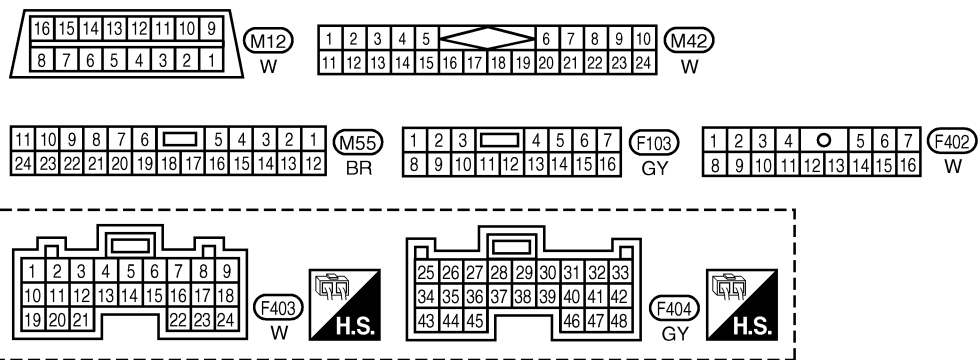

REFER TO THE FOLLOWING.
 (F12), (F201) SUPER MULTIPLE JUNCTION (SMJ)
 (F101) ELECTRICAL UNITS

EL
IDX

TROUBLE DIAGNOSES FOR SYMPTOMS

1. O/D OFF Indicator Lamp Does Not Come On

1. O/D OFF Indicator Lamp Does Not Come On NDAT0084

SYMPTOM:

O/D OFF indicator lamp does not come on for about 2 seconds when turning ignition switch to ON.

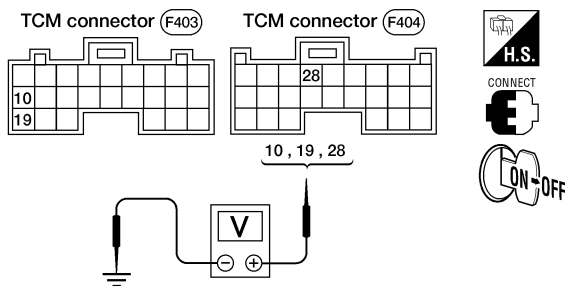
1	CHECK TCM POWER SOURCE-STEP 1	<p>1. Turn ignition switch to ON position. (Do not start engine.)</p> <p>2. Check voltage between TCM terminals 10, 19, 28 and ground.</p> <div style="text-align: center;">  </div> <p style="color: blue; margin-left: 20px;">Voltage: Battery voltage</p> <p style="text-align: center; margin-top: 20px;">OK or NG</p>	AAT347A
OK	▶	GO TO 2.	
NG	▶	<p>Check the following items:</p> <ul style="list-style-type: none"> ● Harness for short or open between ignition switch and TCM (Main harness) Refer to "Wiring Diagram — AT — MAIN", AT-100. ● Ignition switch and fuse Refer to EL-10, "POWER SUPPLY ROUTING". 	

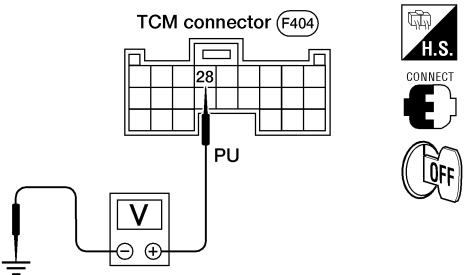
2	CHECK TCM POWER SOURCE STEP-2	<p>1. Turn ignition switch to OFF position.</p> <p>2. Check voltage between TCM terminal 28 and ground.</p> <div style="text-align: center;">  </div> <p style="color: blue; margin-left: 20px;">Voltage Battery Voltage</p> <p style="margin-left: 20px;">If OK, check harness for short to ground and short to power.</p> <p style="text-align: center; margin-top: 20px;">OK or NG</p>	WAT067
OK	▶	GO TO 2.	
NG	▶	<p>Check the following items:</p> <ul style="list-style-type: none"> ● Harness for short or open between ignition switch and TCM terminal 28 (Main harness) ● Ignition switch and fuse Refer to EL-10, "POWER SUPPLY AND GROUND". 	

TROUBLE DIAGNOSES FOR SYMPTOMS

1. O/D OFF Indicator Lamp Does Not Come On (Cont'd)

3	CHECK TCM GROUND CIRCUIT		
<p>1. Turn ignition switch to OFF position. 2. Disconnect TCM harness connector. 3. Check continuity between TCM terminals 25, 48 and ground.</p>			
AAT348A			
<p>Continuity should exist. If OK, check harness for short to ground and short to power.</p> <p style="text-align: center;">OK or NG</p>			
OK	▶	GO TO 4.	
NG	▶	Repair open circuit or short to ground or short to power in harness or connectors. Refer to "Wiring Diagram — AT — MAIN", AT-100.	

4	CHECK LAMP CIRCUIT		
<p>1. Turn ignition switch to OFF position. 2. Check resistance between TCM terminals 10 and 13.</p>			
AAT394A			
<p>Resistance: 50 - 100Ω</p> <p>3. Reinstall any part removed.</p> <p style="text-align: center;">OK or NG</p>			
OK	▶	GO TO 5.	
NG	▶	<p>Check the following items:</p> <ul style="list-style-type: none"> ● O/D OFF indicator lamp. ● Harness and fuse for short or open between ignition switch and O/D OFF indicator lamp (Main harness) Refer to EL-10, "POWER SUPPLY ROUTING". ● Harness for short or open between O/D OFF indicator lamp and TCM 	

5	CHECK SYMPTOM		
Check again.			
OK or NG			
OK	▶	INSPECTION END	
NG	▶	<p>1. Perform TCM input/output signal inspection. 2. If NG, recheck TCM pin terminals for damage or loose connection with harness connector.</p>	

GI
MA
EM
LC
EC
FE
AT
AX
SU
BR
ST
RS
BT
HA
SC
EL
IDX

TROUBLE DIAGNOSES FOR SYMPTOMS



2. Engine Cannot Be Started In P and N Position

2. Engine Cannot Be Started In P and N Position

=NDAT0085

SYMPTOM:

- Engine cannot be started with selector lever in P or N position.
- Engine can be started with selector lever in D, 2, 1 or R position.

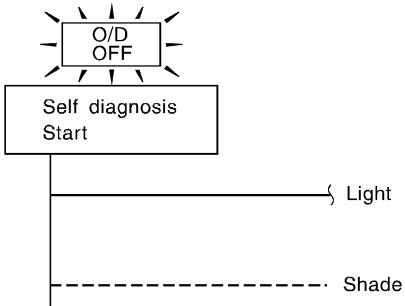
1	CHECK PARK/NEUTRAL POSITION (PNP) SWITCH CIRCUIT	
<p> With CONSULT-II Does "TCM INPUT SIGNAL" in "DATA MONITOR" show damage to park/neutral position (PNP) switch circuit?</p>		
<p> Without CONSULT-II Does self-diagnosis show damage to park/neutral position (PNP) switch circuit?</p>		
		
SAT367J		
Yes or No		
Yes	▶	Check park/neutral position (PNP) switch circuit. Refer to "DTC P0705 PARK/NEUTRAL POSITION SWITCH", AT-103.
No	▶	GO TO 2.

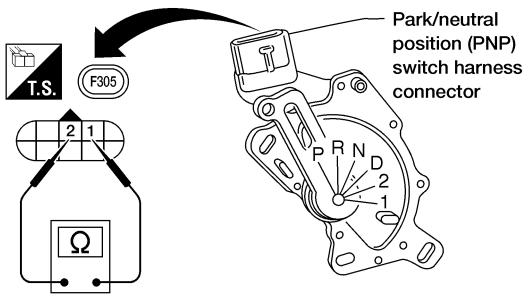
2	CHECK PARK/NEUTRAL POSITION (PNP) SWITCH	
<p>Check for short or open of park/neutral position (PNP) switch harness connector terminals 1 and 2. Refer to "Component Inspection", AT-109.</p>		
		
AAT395A		
OK or NG		
OK	▶	GO TO 3.
NG	▶	Repair or replace park/neutral position (PNP) switch.

3	CHECK STARTING SYSTEM	
<p>Check starting system. Refer to SC-10, "System Description".</p>		
OK or NG		
OK	▶	INSPECTION END
NG	▶	Repair or replace damaged parts.

TROUBLE DIAGNOSES FOR SYMPTOMS

3. In P Position, Vehicle Moves Forward or Backward When Pushed

3. In P Position, Vehicle Moves Forward or Backward When Pushed

=NDAT0086

SYMPTOM:

Vehicle moves when it is pushed forward or backward with selector lever in P position.

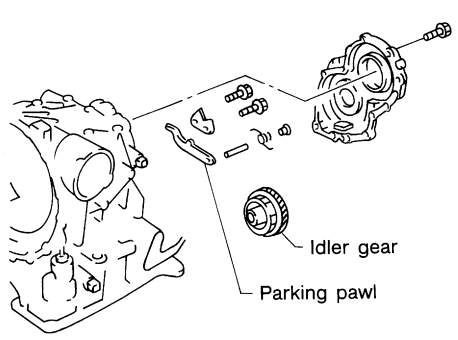
1	CHECK PARKING COMPONENTS		
		Check parking components. Refer to "OVERHAUL", AT-276 and "ASSEMBLY", AT-350.	
		 <p style="text-align: center;">Idler gear Parking pawl</p>	
		SAT282F	AT
OK or NG			
OK	▶	INSPECTION END	AX
NG	▶	Repair or replace damaged parts.	SU

GI

MA

EM

LC

EC

FE

AT

AX

SU

BR

ST

RS

BT

HA

SC

EL

IDX

TROUBLE DIAGNOSES FOR SYMPTOMS

4. In N Position, Vehicle Moves

4. In N Position, Vehicle Moves

=NDAT0087

SYMPTOM:

Vehicle moves forward or backward when selecting N position.

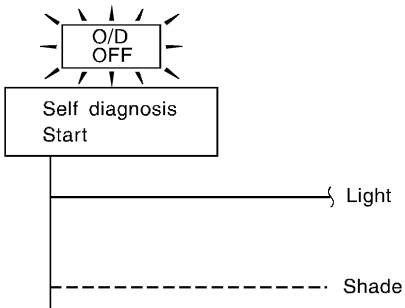
1	CHECK PARK/NEUTRAL POSITION (PNP) SWITCH CIRCUIT	
<p><input type="checkbox"/> With CONSULT-II Does "TCM INPUT SIGNALS" in "DATA MONITOR" show damage to park/neutral position (PNP) switch circuit?</p>		
<p><input checked="" type="checkbox"/> Without CONSULT-II Does self-diagnosis show damage to park/neutral position (PNP) switch circuit?</p>		
		
SAT367J		
Yes or No		
Yes	▶	Check park/neutral position (PNP) switch circuit. Refer to "DTC P0705 PARK/NEUTRAL POSITION SWITCH", AT-103.
No	▶	GO TO 2.

2	CHECK CONTROL LINKAGE	
Check control cable. Refer to "Control Cable Adjustment", AT-272.		
OK or NG		
OK	▶	GO TO 4.
NG	▶	GO TO 3.

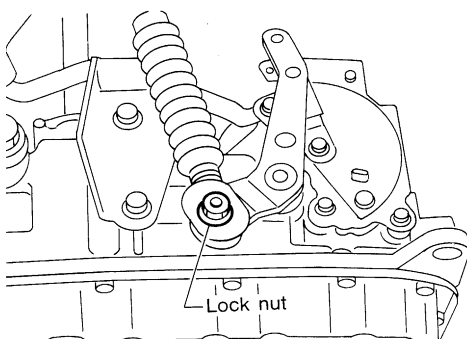
3	ADJUST CONTROL CABLE	
Adjust control cable.		
		
SAT405F		
▶		Refer to "Control Cable Adjustment", AT-272.

TROUBLE DIAGNOSES FOR SYMPTOMS

4. In N Position, Vehicle Moves (Cont'd)

4	CHECK A/T FLUID LEVEL
Check A/T fluid level again.	
	
SAT638A	
OK or NG	
OK	▶ GO TO 5.
NG	▶ Refill ATF.

GI
MA
EM
LC
EC
FE

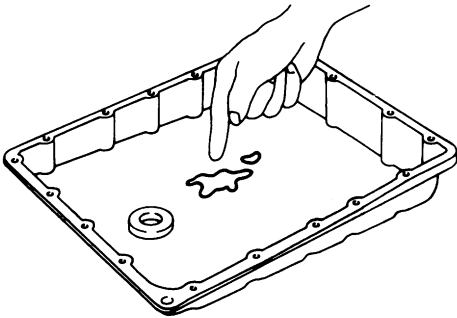
5	CHECK A/T FLUID CONDITION
<ol style="list-style-type: none"> 1. Remove oil pan. 2. Check A/T fluid condition. 	
	
SAT171B	
OK or NG	
OK	▶ GO TO 6.
NG	▶ <ol style="list-style-type: none"> 1. Disassemble A/T. 2. Check the following items: <ul style="list-style-type: none"> ● Forward clutch assembly ● Overrun clutch assembly ● Reverse clutch assembly

AT
AX
SU
BR
ST
RS
BT
HA
SC

6	CHECK SYMPTOM
Check again.	
OK or NG	
OK	▶ INSPECTION END
NG	▶ <ol style="list-style-type: none"> 1. Perform TCM input/output signal inspection. 2. If NG, recheck TCM pin terminals for damage or loose connection with harness connector.

EL
IDX

TROUBLE DIAGNOSES FOR SYMPTOMS

5. Large Shock. N → R Position

5. Large Shock. N → R Position

=NDAT0088

SYMPTOM:

There is large shock when changing from N to R position.

1	CHECK SELF-DIAGNOSTIC RESULTS		
Does self-diagnosis show damage to A/T fluid temperature sensor, line pressure solenoid valve or throttle position sensor circuit?			
SAT345HA			
Yes or No			
Yes	▶	GO TO 2.	
No	▶	GO TO 3.	

2	CHECK DAMAGED CIRCUIT		
Check damaged circuit.			
AAT396A			
▶		Refer to "DTC P0710, P0745 or P1705", AT-110, 167 or 185.	

TROUBLE DIAGNOSES FOR SYMPTOMS

5. Large Shock. N → R Position (Cont'd)

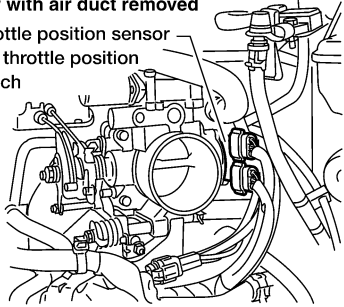
3	CHECK THROTTLE POSITION SENSOR	
Check throttle position sensor. Refer to EC-160 , "Throttle Position Sensor (DTC: 0403)".		
<p>View with air duct removed</p> <p>Throttle position sensor and throttle position switch</p>  <p style="text-align: right;">LAT398</p>		
OK or NG		
OK	▶	GO TO 4.
NG	▶	Repair or replace throttle position sensor.

GI
MA
EM
LC
EC
FE

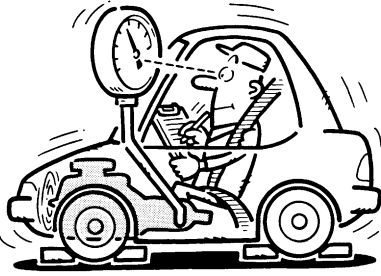
4	CHECK LINE PRESSURE	
Check line pressure at idle with selector lever in D position. Refer to "Line Pressure Test", AT-65.		
 <p style="text-align: right;">SAT494G</p>		
OK or NG		
OK	▶	GO TO 5.
NG	▶	<ol style="list-style-type: none"> 1. Remove control valve assembly. Refer to "Control Valve Assembly and Accumulators", AT-270. 2. Check the following items: <ul style="list-style-type: none"> ● Valves to control line pressure (Pressure regulator valve, pressure modifier valve, pilot valve and pilot filter) ● Line pressure solenoid valve

AT
AX
SU
BR
ST
RS
BT
HA
SC

5	CHECK SYMPTOM	
Check again.		
OK or NG		
OK	▶	INSPECTION END
NG	▶	<ol style="list-style-type: none"> 1. Perform TCM input/output signal inspection. 2. If NG, recheck TCM pin terminals for damage or loose connection with harness connector.

EL
IDX

TROUBLE DIAGNOSES FOR SYMPTOMS

6. Vehicle Does Not Creep Backward In R Position

6. Vehicle Does Not Creep Backward In R Position

=NDAT0089

SYMPTOM:

Vehicle does not creep backward when selecting R position.

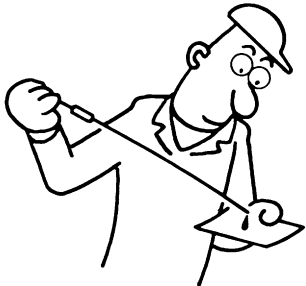
1	CHECK A/T FLUID LEVEL
Check A/T fluid level again.	
	
SAT638A	
OK or NG	
OK	▶ GO TO 2.
NG	▶ Refill ATF.

TROUBLE DIAGNOSES FOR SYMPTOMS

6. Vehicle Does Not Creep Backward In R Position (Cont'd)

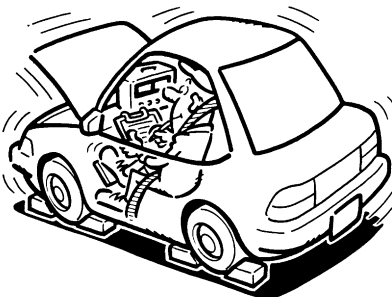
2	CHECK STALL REVOLUTION	
Check stall revolution with selector lever in 1 and R positions.		
 <p data-bbox="1380 567 1477 598">SAT493G</p> <p data-bbox="747 609 876 640">OK or NG</p>		
OK	▶	GO TO 3.
OK in 1 position, NG in R position	▶	<ol style="list-style-type: none"> 1. Remove control valve assembly. Refer to "Control Valve Assembly and Accumulators", AT-270. 2. Check the following items: <ul style="list-style-type: none"> ● Valves to control line pressure (Pressure regulator valve, pressure modifier valve, pilot valve and pilot filter) ● Line pressure solenoid valve 3. Disassemble A/T. 4. Check the following items: <ul style="list-style-type: none"> ● Oil pump assembly ● Torque converter ● Reverse clutch assembly ● High clutch assembly
NG in both 1 and R positions	▶	<ol style="list-style-type: none"> 1. Remove control valve assembly. Refer to "Control Valve Assembly and Accumulators", AT-270. 2. Check the following items: <ul style="list-style-type: none"> ● Valves to control line pressure (Pressure regulator valve, pressure modifier valve, pilot valve and pilot filter) ● Line pressure solenoid valve 3. Disassemble A/T. 4. Check the following items: <ul style="list-style-type: none"> ● Oil pump assembly ● Torque converter ● Reverse clutch assembly ● High clutch assembly ● Low & reverse brake assembly ● Low one-way clutch

GI
MA
EM
LC
EC
EC
FE
AT
AX
SU
BR
ST
RS
BT
HA
SC
EL
IDX

TROUBLE DIAGNOSES FOR SYMPTOMS

6. Vehicle Does Not Creep Backward In R Position (Cont'd)

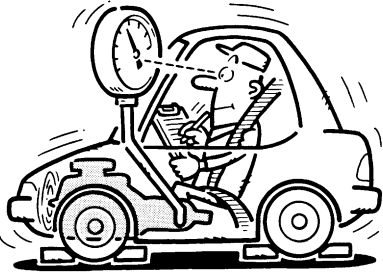
3	CHECK LINE PRESSURE	<p>Check line pressure at idle with selector lever in R position. Refer to "LINE PRESSURE TEST", AT-65.</p> <div style="text-align: center;">  </div> <p style="text-align: right;">SAT494G</p> <p style="text-align: center;">OK or NG</p>
OK	▶	GO TO 4.
NG	▶	<ol style="list-style-type: none"> 1. Remove control valve assembly. Refer to "Control Valve Assembly and Accumulators", AT-270. 2. Check the following items: <ul style="list-style-type: none"> ● Valves to control line pressure (Pressure regulator valve, pressure modifier valve, pilot valve and pilot filter) ● Line pressure solenoid valve 3. Disassemble A/T. 4. Check the following item: <ul style="list-style-type: none"> ● Oil pump assembly

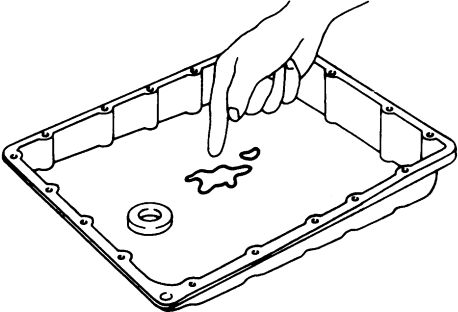
4	CHECK A/T FLUID CONDITION	<ol style="list-style-type: none"> 1. Remove oil pan. 2. Check A/T fluid condition. <div style="text-align: center;">  </div> <p style="text-align: right;">SAT171B</p> <p style="text-align: center;">OK or NG</p>
OK	▶	GO TO 5.
NG	▶	<ol style="list-style-type: none"> 1. Remove control valve assembly. Refer to "Control Valve Assembly and Accumulators", AT-270. 2. Check the following items: <ul style="list-style-type: none"> ● Valves to control line pressure (Pressure regulator valve, pressure modifier valve, pilot valve and pilot filter) ● Line pressure solenoid valve 3. Disassemble A/T. 4. Check the following items: <ul style="list-style-type: none"> ● Oil pump assembly ● Torque converter ● Reverse clutch assembly ● High clutch assembly ● Low & reverse brake assembly ● Low one-way clutch

TROUBLE DIAGNOSES FOR SYMPTOMS

6. Vehicle Does Not Creep Backward In R Position (Cont'd)

5	CHECK SYMPTOM	
Check again.		
OK or NG		
OK	▶	INSPECTION END
NG	▶	<ol style="list-style-type: none"> 1. Perform TCM input/output signal inspection. 2. If NG, recheck TCM pin terminals for damage or loose connection with harness connector.

GI

MA

EM

LC

EC

FE

AT

AX

SU

BR

ST

RS

BT

HA

SC

EL

IDX

TROUBLE DIAGNOSES FOR SYMPTOMS

7. Vehicle Does Not Creep Forward in D, 2 or 1 Position

7. Vehicle Does Not Creep Forward in D, 2 or 1 Position

=NDAT0090

SYMPTOM:

Vehicle does not creep forward when selecting D, 2 or 1 position.

1	CHECK A/T FLUID LEVEL	
Check A/T fluid level again.		
		
SAT638A		
OK or NG		
OK	▶	GO TO 2.
NG	▶	Refill ATF.

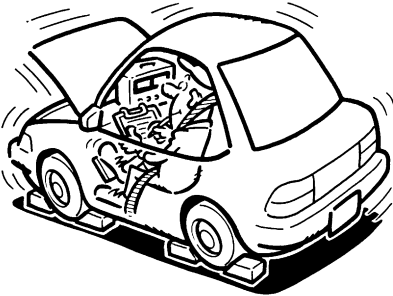
2	CHECK STALL REVOLUTION	
Check stall revolution with selector lever in D position. Refer to "Stall Test", AT-61.		
		
SAT493G		
OK or NG		
OK	▶	GO TO 3.
NG	▶	<ol style="list-style-type: none"> 1. Remove control valve assembly. Refer to "Control Valve Assembly and Accumulators", AT-270. 2. Check the following items: <ul style="list-style-type: none"> ● Valves to control line pressure (Pressure regulator valve, pressure modifier valve, pilot valve and pilot filter) ● Line pressure solenoid valve 3. Disassemble A/T. 4. Check the following items: <ul style="list-style-type: none"> ● Oil pump assembly ● Forward clutch assembly ● Forward one-way clutch ● Low one-way clutch ● Low & reverse brake assembly ● Torque converter

TROUBLE DIAGNOSES FOR SYMPTOMS

7. Vehicle Does Not Creep Forward in D, 2 or 1 Position (Cont'd)

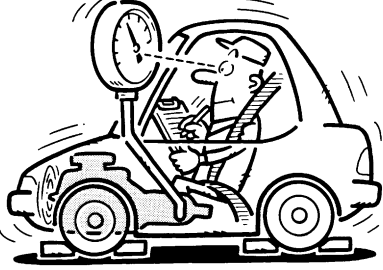
3	CHECK LINE PRESSURE	<p>Check line pressure at idle with selector lever in D position. Refer to "Line Pressure Test", AT-65.</p> <div style="text-align: center;">  </div> <p style="text-align: right;">SAT494G</p> <p style="text-align: center;">OK or NG</p>
OK	▶	GO TO 4.
NG	▶	<ol style="list-style-type: none"> 1. Remove control valve assembly. Refer to "Control Valve Assembly and Accumulators", AT-270. 2. Check the following items: <ul style="list-style-type: none"> ● Valves to control line pressure (Pressure regulator valve, pressure modifier valve, pilot valve and pilot filter) ● Line pressure solenoid valve 3. Disassemble A/T. 4. Check the following item: <ul style="list-style-type: none"> ● Oil pump assembly

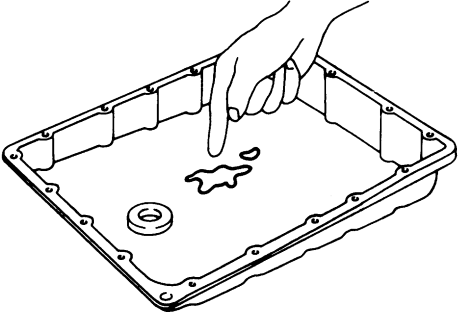
4	CHECK A/T FLUID CONDITION	<ol style="list-style-type: none"> 1. Remove oil pan. 2. Check A/T fluid condition. <div style="text-align: center;">  </div> <p style="text-align: right;">SAT171B</p> <p style="text-align: center;">OK or NG</p>
OK	▶	GO TO 5.
NG	▶	<ol style="list-style-type: none"> 1. Remove control valve assembly. Refer to "Control Valve Assembly and Accumulators", AT-270. 2. Check the following items: <ul style="list-style-type: none"> ● Valves to control line pressure (Pressure regulator valve, pressure modifier valve, pilot valve and pilot filter) ● Line pressure solenoid valve 3. Disassemble A/T. 4. Check the following items: <ul style="list-style-type: none"> ● Oil pump assembly ● Forward clutch assembly ● Forward one-way clutch ● Low one-way clutch ● Low & reverse brake assembly ● Torque converter

GI
MA
EM
LC
EC
FE
AT
AX
SU
BR
ST
RS
BT
HA
SC
EL
IDX

TROUBLE DIAGNOSES FOR SYMPTOMS

7. Vehicle Does Not Creep Forward in D, 2 or 1 Position (Cont'd)

5	CHECK SYMPTOM
Check again.	
OK or NG	
OK	▶ INSPECTION END
NG	▶ 1. Perform TCM input/output signal inspection. 2. If NG, recheck TCM pin terminals for damage or loose connection with harness connector.

TROUBLE DIAGNOSES FOR SYMPTOMS

8. Vehicle Cannot Be Started From D₁

8. Vehicle Cannot Be Started From D₁

=NDAT0091

SYMPTOM:

Vehicle cannot be started from D₁ on Cruise test — Part 1.

1	CHECK SYMPTOM	
Is 6. Vehicle Does Not Creep Backward In R Position OK?		
Yes or No		
Yes	▶	GO TO 2.
No	▶	Go to "6. Vehicle Does Not Creep Backward In R Position", AT-224.

2	CHECK SELF-DIAGNOSTIC RESULTS	
Does self-diagnosis show damage to vehicle speed sensor-A/T (revolution sensor), shift solenoid valve A, B or vehicle speed sensor-MTR after cruise test?		
SAT934FB		
Yes or No		
Yes	▶	Check damaged circuit. Refer to "DTC P0720, P0750, P0755 or VHCL SPEED SEN-MTR", AT-117, 173, 179 or 205.
No	▶	GO TO 3.

3	CHECK THROTTLE POSITION SENSOR	
Check throttle position sensor. Refer to EC-169 , "Throttle Position Sensor (DTC: 0403)".		
AAT794		
OK or NG		
OK	▶	GO TO 4.
NG	▶	Repair or replace throttle position sensor.

TROUBLE DIAGNOSES FOR SYMPTOMS

8. Vehicle Cannot Be Started From D₁ (Cont'd)

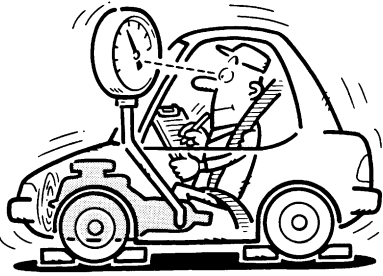
4	CHECK LINE PRESSURE
Check line pressure at stall point with selector lever in D position. Refer to "Line Pressure Test", AT-65.	
	
SAT494G	
OK or NG	
OK	▶ GO TO 6.
NG	▶ GO TO 5.

5	DETECT MALFUNCTIONING ITEM
1. Remove control valve assembly. Refer to "Control Valve Assembly and Accumulators", AT-270. 2. Check the following items: <ul style="list-style-type: none">● Shift valve A● Shift valve B● Shift solenoid valve A● Shift solenoid valve B● Pilot valve● Pilot filter 3. Disassemble A/T. 4. Check the following items: <ul style="list-style-type: none">● Forward clutch assembly● Forward one-way clutch● Low one-way clutch● High clutch assembly● Torque converter● Oil pump assembly	
OK or NG	
OK	▶ GO TO 8.
NG	▶ Repair or replace damaged parts.

TROUBLE DIAGNOSES FOR SYMPTOMS

8. Vehicle Cannot Be Started From D₁ (Cont'd)

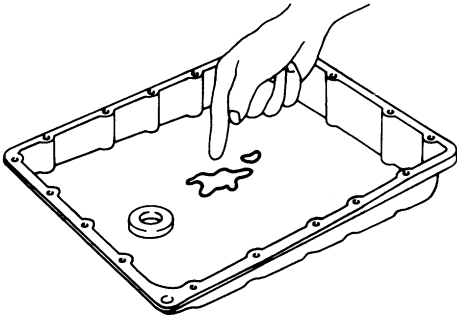
6	CHECK A/T FLUID CONDITION	
<p>1. Remove oil pan. 2. Check A/T fluid condition.</p> <div style="text-align: center;">  </div> <p style="text-align: right;">SAT171B</p>		
OK or NG		
OK	▶	GO TO 7.
NG	▶	GO TO 5.

GI
MA
EM
LC
EC
FE

7	DETECT MALFUNCTIONING ITEM	
<p>1. Remove control valve assembly. Refer to "Control Valve Assembly and Accumulators", AT-270. 2. Check the following items:</p> <ul style="list-style-type: none"> ● Shift valve A ● Shift valve B ● Shift solenoid valve A ● Shift solenoid valve B ● Pilot valve ● Pilot filter 		
OK or NG		
OK	▶	GO TO 8.
NG	▶	Repair or replace damage parts.

AT
AX
SU
BR
ST

8	CHECK SYMPTOM	
Check again.		
OK or NG		
OK	▶	INSPECTION END
NG	▶	<p>1. Perform TCM input/output signal inspection. 2. If NG, recheck TCM pin terminals for damage or loose connection with harness connector.</p>

RS
BT
HA
SC
EL
IDX

TROUBLE DIAGNOSES FOR SYMPTOMS

9. A/T Does Not Shift: $D_1 \rightarrow D_2$ or Does Not Kickdown: $D_4 \rightarrow D_2$

9. A/T Does Not Shift: $D_1 \rightarrow D_2$ or Does Not Kickdown: $D_4 \rightarrow D_2$

=NDAT0092

SYMPTOM:

A/T does not shift from D_1 to D_2 at the specified speed.

A/T does not shift from D_4 to D_2 when depressing accelerator pedal fully at the specified speed.

1	CHECK SYMPTOM	
Are 7. Vehicle Does Not Creep Forward In D, 2 Or 1 Position and 8. Vehicle Cannot Be Started From D_1 OK?		
Yes or No		
Yes	▶	GO TO 2.
No	▶	Go to "7. Vehicle Does Not Creep Forward In D, 2 Or 1 Position" and "8. Vehicle Cannot Be Started From D_1 ", AT-228, AT-231.

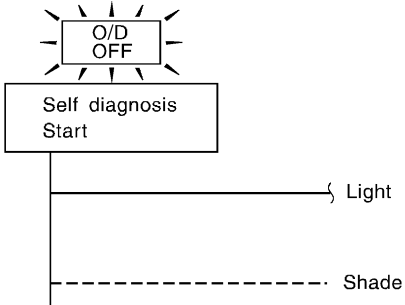
2	CHECK SELF-DIAGNOSTIC RESULTS	
<input type="checkbox"/> With CONSULT-II Does "TCM INPUT SIGNALS" in "DATA MONITOR" show damage to park/neutral position (PNP) switch circuit?		
<input checked="" type="checkbox"/> Without CONSULT-II Does self-diagnosis show damage to park/neutral position (PNP) switch circuit?		
		
Yes or No		
Yes	▶	Check park/neutral position (PNP) switch circuit. Refer to "DTC P0705 PARK/NEUTRAL POSITION SWITCH", AT-103.
No	▶	GO TO 3.

SAT367J

3	CHECK VEHICLE SPEED SENSOR-A/T AND VEHICLE SPEED SENSOR-MTR CIRCUIT	
Check vehicle speed sensor-A/T (revolution sensor) and vehicle speed sensor-MTR circuit. Refer to "DTC P0720 VEHICLE SPEED SENSOR-A/T (REVOLUTION SENSOR)" and "DTC VHCL SPEED SEN-MTR", AT-117, AT-205.		
OK or NG		
OK	▶	GO TO 4.
NG	▶	Repair or replace vehicle speed sensor-A/T (revolution sensor) and vehicle speed sensor-MTR circuits.

TROUBLE DIAGNOSES FOR SYMPTOMS

9. A/T Does Not Shift: D₁ → D₂ or Does Not Kickdown: D₄ → D₂ (Cont'd)

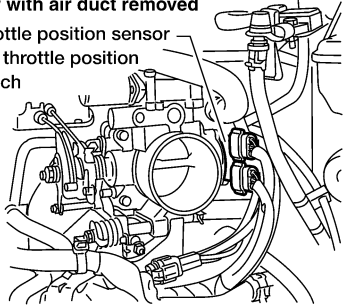
4	CHECK THROTTLE POSITION SENSOR	
<p>Check throttle position sensor. Refer to EC-169, "Throttle Position Sensor (DTC: 0403)".</p> <p style="text-align: center;">View with air duct removed Throttle position sensor and throttle position switch</p>  <p style="text-align: right;">LAT398</p> <p style="text-align: center;">OK or NG</p>		
OK	▶	GO TO 5.
NG	▶	Repair or replace throttle position sensor.

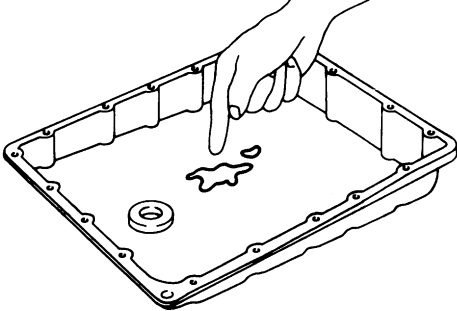
5	CHECK A/T FLUID CONDITION	
<p>1. Remove oil pan. 2. Check A/T fluid condition.</p>  <p style="text-align: right;">SAT171B</p> <p style="text-align: center;">OK or NG</p>		
OK	▶	GO TO 7.
NG	▶	GO TO 6.

6	DETECT MALFUNCTIONING ITEM	
<p>1. Remove control valve. Refer to "Control Valve Assembly and Accumulators", AT-270. 2. Check the following items:</p> <ul style="list-style-type: none"> ● Shift valve A ● Shift solenoid valve A ● Pilot valve ● Pilot filter <p>3. Disassemble A/T. 4. Check the following items:</p> <ul style="list-style-type: none"> ● Servo piston assembly ● Brake band ● Oil pump assembly <p style="text-align: center;">OK or NG</p>		
OK	▶	GO TO 8.
NG	▶	Repair or replace damaged parts.

GI

MA

EM

LC

EC

FE

AT

AX

SU

BR

ST

RS

BT

HA

SC

EL

IDX

TROUBLE DIAGNOSES FOR SYMPTOMS

9. *A/T Does Not Shift: D₁ → D₂ or Does Not Kickdown: D₄ → D₂ (Cont'd)*

7	DETECT MALFUNCTIONING ITEM	
<p>1. Remove control valve. Refer to "Control Valve Assembly and Accumulators", AT-270.</p> <p>2. Check the following items:</p> <ul style="list-style-type: none"> ● Shift valve A ● Shift solenoid valve A ● Pilot valve ● Pilot filter 		
OK or NG		
OK	▶	GO TO 8.
NG	▶	Repair or replace damaged parts.

8	CHECK SYMPTOM	
Check again.		
OK or NG		
OK	▶	INSPECTION END
NG	▶	<p>1. Perform TCM input/output signal inspection.</p> <p>2. If NG, recheck TCM pin terminals for damage or loose connection with harness connector.</p>

TROUBLE DIAGNOSES FOR SYMPTOMS

10. A/T Does Not Shift: D₂ → D₃

10. A/T Does Not Shift: D₂ → D₃

=NDAT0093

SYMPTOM:

A/T does not shift from D₂ to D₃ at the specified speed.

1	CHECK SYMPTOM	
Are 7. Vehicle Does Not Creep Forward In D, 2 Or 1 Position and 8. Vehicle Cannot Be Started From D ₁ OK?		
Yes or No		
Yes	▶	GO TO 2.
No	▶	Go to "7. Vehicle Does Not Creep Forward In D, 2 Or 1 Position" and "8. Vehicle Cannot Be Started From D ₁ ", AT-228, AT-231.

2	CHECK PARK/NEUTRAL POSITION (PNP) SWITCH CIRCUIT	
<input type="checkbox"/> With CONSULT-II Does "TCM INPUT SIGNALS" in "DATA MONITOR" show damage to park/neutral position (PNP) switch circuit?		
<input checked="" type="checkbox"/> Without CONSULT-II Does self-diagnosis show damage to park/neutral position (PNP) switch circuit?		
Yes or No		
Yes	▶	Check park/neutral position (PNP) switch circuit. Refer to "DTC P0705 PARK/NEUTRAL POSITION SWITCH", AT-103.
No	▶	GO TO 3.

3	CHECK THROTTLE POSITION SENSOR	
Check throttle position sensor. Refer to EC-169 , "Throttle Position Sensor (DTC: 0403)".		
<p>View with air duct removed</p> <p>Throttle position sensor and throttle position switch</p>		
OK or NG		
OK	▶	GO TO 4.
NG	▶	Repair or replace throttle position sensor.

GI

MA

EM

LC

EC

FE

AT

AX

SU

BR

ST

RS

BT

HA

SC

EL

IDX

SAT367J

LAT398

TROUBLE DIAGNOSES FOR SYMPTOMS

10. A/T Does Not Shift: $D_2 \rightarrow D_3$ (Cont'd)

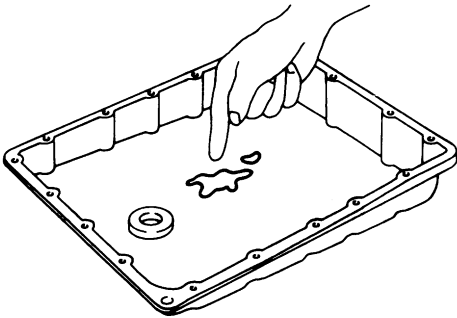
4	CHECK A/T FLUID CONDITION	
<p>1. Remove oil pan. 2. Check A/T fluid condition.</p>		
		
SAT171B		
OK or NG		
OK	▶	GO TO 6.
NG	▶	GO TO 5.

5	DETECT MALFUNCTIONING ITEM	
<p>1. Remove control valve assembly. Refer to "Control Valve Assembly and Accumulators", AT-270. 2. Check the following items:</p> <ul style="list-style-type: none"> ● Shift valve B ● Shift solenoid valve B ● Pilot valve ● Pilot filter <p>3. Disassemble A/T. 4. Check the following items:</p> <ul style="list-style-type: none"> ● Servo piston assembly ● High clutch assembly ● Oil pump assembly 		
OK or NG		
OK	▶	GO TO 7.
NG	▶	Repair or replace damaged parts.

6	DETECT MALFUNCTIONING ITEM	
<p>1. Remove control valve assembly. Refer to "Control Valve Assembly and Accumulators", AT-270. 2. Check the following items:</p> <ul style="list-style-type: none"> ● Shift valve B ● Shift solenoid valve B ● Pilot valve ● Pilot filter 		
OK or NG		
OK	▶	GO TO 7.
NG	▶	Repair or replace damaged parts.

TROUBLE DIAGNOSES FOR SYMPTOMS

10. A/T Does Not Shift: D₂ → D₃ (Cont'd)

7	CHECK SYMPTOM	
Check again.		
OK or NG		
OK	▶	INSPECTION END
NG	▶	<ol style="list-style-type: none"> 1. Perform TCM input/output signal inspection. 2. If NG, recheck TCM pin terminals for damage or loose connection with harness connector.

GI

MA

EM

LC

EC

FE

AT

AX

SU

BR

ST

RS

BT

HA

SC

EL

IDX

TROUBLE DIAGNOSES FOR SYMPTOMS

11. A/T Does Not Shift: D₃ → D₄

11. A/T Does Not Shift: D₃ → D₄

=NDAT0094

SYMPTOM:

- A/T does not shift from D₃ to D₄ at the specified speed.
- A/T must be warm before D₃ to D₄ shift will occur.

1	CHECK SYMPTOM	
Are 7. Vehicle Does Not Creep Forward In D, 2 Or 1 Position and 8. Vehicle Cannot Be Started From D ₁ OK?		
Yes or No		
Yes	▶	GO TO 2.
No	▶	Go to "7. Vehicle Does Not Creep Forward In D, 2 Or 1 Position" and "8. Vehicle Cannot Be Started From D ₁ ", AT-228, AT-231.

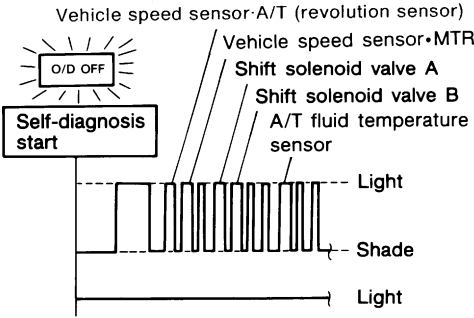
2	CHECK SELF-DIAGNOSTIC RESULTS	
<p>④ With CONSULT-II Does "TCM INPUT SIGNALS" in "DATA MONITOR" show damage to any of the following circuits?</p> <ul style="list-style-type: none"> ● Park/neutral position (PNP) switch ● Overdrive control switch ● A/T fluid temperature sensor ● Vehicle speed sensor·A/T (revolution sensor) ● Shift solenoid valve A or B ● Vehicle speed sensor·MTR 		
<p>⊗ Without CONSULT-II Does self-diagnosis, after cruise test, show damage to any of the following circuits?</p> <ul style="list-style-type: none"> ● Does self-diagnosis, after cruise test, show damage to any of the following circuits? ● Park/neutral position (PNP) switch ● Overdrive control switch ● A/T fluid temperature sensor ● Vehicle speed sensor·A/T (revolution sensor) ● Shift solenoid valve A or B ● Vehicle speed sensor·MTR 		
		
SAT363HC		
Yes or No		
Yes	▶	Check damaged circuit. Refer to "DTC P0705, P0710, P0720, P0750, P0755 or VHCL SPEED SEN·MTR", AT-103, AT-110, AT-117, AT-173, AT-179 or AT-205.
No	▶	GO TO 3.

TROUBLE DIAGNOSES FOR SYMPTOMS

11. A/T Does Not Shift: D₃ → D₄ (Cont'd)

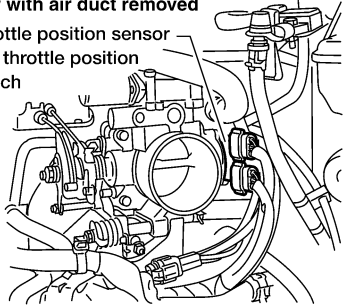
3	CHECK THROTTLE POSITION SENSOR	
<p>Check throttle position sensor. Refer to EC-169, "Throttle Position Sensor (DTC: 0403)".</p> <p style="text-align: center;">View with air duct removed Throttle position sensor and throttle position switch</p>  <p style="text-align: right;">LAT398</p> <p style="text-align: center;">OK or NG</p>		
OK	▶	GO TO 4.
NG	▶	Repair or replace throttle position sensor.

GI
MA
EM
LC
EC
FE

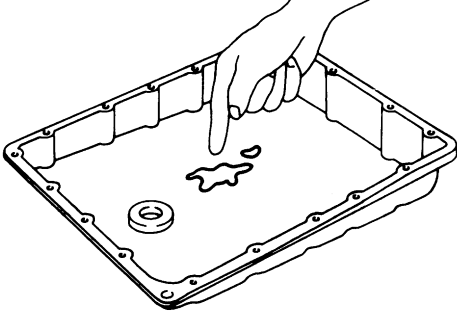
4	CHECK A/T FLUID CONDITION	
<p>1. Remove oil pan. 2. Check A/T fluid condition.</p>  <p style="text-align: right;">SAT171B</p> <p style="text-align: center;">OK or NG</p>		
OK	▶	GO TO 6.
NG	▶	GO TO 5.

AT
AX
SU
BR
ST
RS
BT
HA

5	DETECT MALFUNCTIONING ITEM	
<p>1. Remove control valve assembly. Refer to "Control Valve Assembly and Accumulators", AT-270. 2. Check the following items:</p> <ul style="list-style-type: none"> ● Shift valve B ● Overrun clutch control valve ● Shift solenoid valve B ● Pilot valve ● Pilot filter <p>3. Disassemble A/T. 4. Check the following items:</p> <ul style="list-style-type: none"> ● Servo piston assembly ● Brake band ● Torque converter ● Oil pump assembly <p style="text-align: center;">OK or NG</p>		
OK	▶	GO TO 7.
NG	▶	Repair or replace damaged parts.

SC
EL
IDX

TROUBLE DIAGNOSES FOR SYMPTOMS

11. A/T Does Not Shift: $D_3 \rightarrow D_4$ (Cont'd)

6	DETECT MALFUNCTIONING ITEM	
<p>1. Remove control valve assembly. Refer to "Control Valve Assembly and Accumulators", AT-270.</p> <p>2. Check the following items:</p> <ul style="list-style-type: none"> ● Shift valve B ● Overrun clutch control valve ● Shift solenoid valve B ● Pilot valve ● Pilot filter 		
OK or NG		
OK	▶	GO TO 7.
NG	▶	Repair or replace damaged parts.

7	CHECK SYMPTOM	
Check again.		
OK or NG		
OK	▶	INSPECTION END
NG	▶	<p>1. Perform TCM input/output signal inspection.</p> <p>2. If NG, recheck TCM pin terminals for damage or loose connection with harness connector.</p>

TROUBLE DIAGNOSES FOR SYMPTOMS

12. A/T Does Not Perform Lock-up

12. A/T Does Not Perform Lock-up

=NDAT0095

SYMPTOM:

A/T does not perform lock-up at the specified speed.

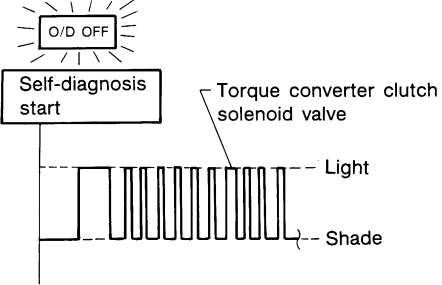
1	CHECK SELF-DIAGNOSTIC RESULTS	
Does self-diagnosis show damage to torque converter clutch solenoid valve circuit after cruise test?		
		
SAT346H		
Yes or No		
Yes	▶	Check torque converter clutch solenoid valve circuit. Refer to "DTC P0740 TORQUE CONVERTER CLUTCH SOLENOID VALVE", AT-154.
No	▶	GO TO 2.

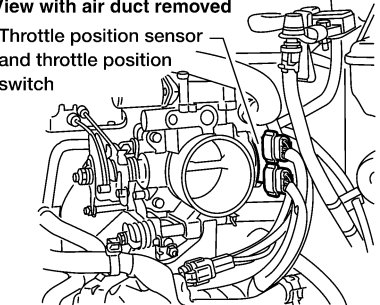
2	CHECK THROTTLE POSITION SENSOR	
Check throttle position sensor. Refer to EC-160 , "TROUBLE DIAGNOSIS FOR DTC P0120".		
<p>View with air duct removed</p> 		
LAT398		
OK or NG		
OK	▶	GO TO 3.
NG	▶	Repair or replace throttle position sensor.

3	DETECT MALFUNCTIONING ITEM	
<ol style="list-style-type: none"> 1. Remove control valve. Refer to "Control Valve Assembly and Accumulators", AT-270. 2. Check following items: <ul style="list-style-type: none"> ● Torque converter clutch control valve ● Torque converter relief valve ● Torque converter clutch solenoid valve ● Pilot valve ● Pilot filter 		
OK or NG		
OK	▶	GO TO 4.
NG	▶	Repair or replace damaged parts.

GI

MA

EM

LC

EC

FE

AT

AX

SU

BR

ST

RS

BT

HA

SC

EL

IDX

TROUBLE DIAGNOSES FOR SYMPTOMS

12. A/T Does Not Perform Lock-up (Cont'd)

4	CHECK SYMPTOM
Check again.	
OK or NG	
OK	▶ INSPECTION END
NG	▶ 1. Perform TCM input/output signal inspection. 2. If NG, recheck TCM pin terminals for damage or loose connection with harness connector.

TROUBLE DIAGNOSES FOR SYMPTOMS

13. A/T Does Not Hold Lock-up Condition

13. A/T Does Not Hold Lock-up Condition

=NDAT0096

SYMPTOM:

A/T does not hold lock-up condition for more than 30 seconds.

1	CHECK SELF-DIAGNOSTIC RESULTS	
Does self-diagnosis show damage to engine speed signal circuit after cruise test?		
SAT347H		
Yes or No		
Yes	▶	Check engine speed signal circuit. Refer to "DTC P0725 ENGINE SPEED SIGNAL", AT-123.
No	▶	GO TO 2.

2	CHECK A/T FLUID CONDITION	
<ol style="list-style-type: none"> 1. Remove oil pan. 2. Check A/T fluid condition. 		
SAT171B		
OK or NG		
OK	▶	GO TO 4.
NG	▶	GO TO 3.

3	DETECT MALFUNCTIONING ITEM	
<ol style="list-style-type: none"> 1. Remove control valve assembly. Refer to "Control Valve Assembly and Accumulators", AT-270. 2. Check the following items: <ul style="list-style-type: none"> ● Torque converter clutch control valve ● Pilot valve ● Pilot filter 3. Disassemble A/T. 4. Check torque converter and oil pump assembly. 		
OK or NG		
OK	▶	GO TO 5.
NG	▶	Repair or replace damaged parts.

GI

MA

EM

LC

EC

FE

AT

AX

SU

BR

ST

RS

BT

HA

SC

EL

IDX

TROUBLE DIAGNOSES FOR SYMPTOMS

13. A/T Does Not Hold Lock-up Condition (Cont'd)

4	DETECT MALFUNCTIONING ITEM
1. Remove control valve assembly. Refer to "Control Valve Assembly and Accumulators", AT-270. 2. Check the following items: <ul style="list-style-type: none">● Torque converter clutch control valve● Pilot valve● Pilot filter	
OK or NG	
OK	▶ GO TO 5.
NG	▶ Repair or replace damaged parts.

5	CHECK SYMPTOM
Check again.	
OK or NG	
OK	▶ INSPECTION END
NG	▶ <ol style="list-style-type: none">1. Perform TCM input/output signal inspection.2. If NG, recheck TCM pin terminals for damage or loose connection with harness connector.

TROUBLE DIAGNOSES FOR SYMPTOMS

14. Lock-up Is Not Released

14. Lock-up Is Not Released

=NDAT0097

SYMPTOM:

Lock-up is not released when accelerator pedal is released.

1	CHECK THROTTLE POSITION SWITCH CIRCUIT	
<p><input type="checkbox"/> With CONSULT-II Does "TCM INPUT SIGNALS" in "DATA MONITOR" show damage to closed throttle position switch circuit?</p>		
<p><input checked="" type="checkbox"/> Without CONSULT-II Does self-diagnosis show damage to closed throttle position switch circuit?</p>		
SAT367J		
Yes or No		
Yes	▶	Check closed throttle position switch circuit. Refer to "DTC P1705 THROTTLE POSITION SENSOR", AT-185.
No	▶	GO TO 2.

2	CHECK SYMPTOM	
Check again.		
OK or NG		
OK	▶	INSPECTION END
NG	▶	<ol style="list-style-type: none"> 1. Perform TCM input/output signal inspection. 2. If NG, recheck TCM pin terminals for damage or loose connection with harness connector.

GI

MA

EM

LC

EC

FE

AT

AX

SU

BR

ST

RS

BT

HA

SC

EL

IDX

TROUBLE DIAGNOSES FOR SYMPTOMS

15. Engine Speed Does Not Return To Idle (Light Braking $D_4 \rightarrow D_3$)

15. Engine Speed Does Not Return To Idle (Light Braking $D_4 \rightarrow D_3$)

=NDAT0098

SYMPTOM:

- Engine speed does not smoothly return to idle when A/T shifts from D_4 to D_3 .
- Vehicle does not decelerate by engine brake when turning overdrive control switch OFF.
- Vehicle does not decelerate by engine brake when shifting A/T from D to 2 position.

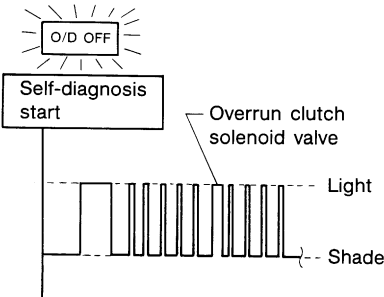
1	CHECK SELF-DIAGNOSTIC RESULTS	
Does self-diagnosis show damage to overrun clutch solenoid valve circuit after cruise test?		
		
SAT348H		
Yes or No		
Yes	▶	Check overrun clutch solenoid valve circuit. Refer to "DTC P1760 OVERRUN CLUTCH SOLENOID VALVE", AT-192.
No	▶	GO TO 2.

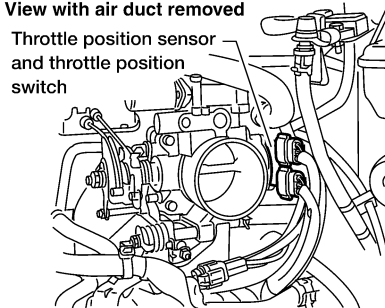
2	CHECK THROTTLE POSITION SENSOR	
Check throttle position sensor. Refer to EC-169 , "Throttle Position Sensor (DTC: 0403)".		
<p>View with air duct removed</p> 		
LAT398		
OK or NG		
OK	▶	GO TO 3.
NG	▶	Repair or replace throttle position sensor.

TROUBLE DIAGNOSES FOR SYMPTOMS

15. Engine Speed Does Not Return To Idle (Light Braking $D_4 \rightarrow D_3$) (Cont'd)

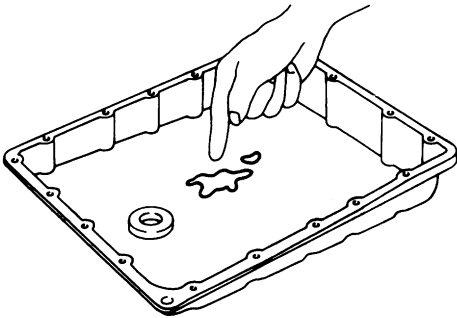
3	CHECK A/T FLUID CONDITION	
<p>1. Remove oil pan. 2. Check A/T fluid condition.</p> <div style="text-align: center;">  </div> <p style="text-align: right;">SAT171B</p>		
OK or NG		
OK	▶	GO TO 5.
NG	▶	GO TO 4.

GI
MA
EM
LC
EC
FE

4	DETECT MALFUNCTIONING ITEM	
<p>1. Remove control valve assembly. Refer to "Control Valve Assembly and Accumulator", AT-270. 2. Check the following items:</p> <ul style="list-style-type: none"> ● Overrun clutch control valve ● Overrun clutch reducing valve ● Overrun clutch solenoid valve <p>3. Disassemble A/T. 4. Check the following items:</p> <ul style="list-style-type: none"> ● Overrun clutch assembly ● Oil pump assembly 		
OK or NG		
OK	▶	GO TO 6.
NG	▶	Repair or replace damaged parts.

AT
AX
SU
BR
ST
RS

5	DETECT MALFUNCTIONING ITEM	
<p>1. Remove control valve assembly. Refer to "Control Valve Assembly and Accumulator", AT-270. 2. Check the following items:</p> <ul style="list-style-type: none"> ● Overrun clutch control valve ● Overrun clutch reducing valve ● Overrun clutch solenoid valve 		
OK or NG		
OK	▶	GO TO 6.
NG	▶	Repair or replace damaged parts.

BT
HA
SC
EL

6	CHECK SYMPTOM	
Check again.		
OK or NG		
OK	▶	INSPECTION END
NG	▶	<p>1. Perform TCM input/output signal inspection. 2. If NG, recheck TCM pin terminals for damage or loose connection with harness connector.</p>

IDX

TROUBLE DIAGNOSES FOR SYMPTOMS

16. Vehicle Does Not Start From D₁

16. Vehicle Does Not Start From D₁

=NDAT0099

SYMPTOM:

Vehicle does not start from D₁ on Cruise test — Part 2.

1	CHECK SELF-DIAGNOSTIC RESULTS	
Does self-diagnosis show damage to vehicle speed sensor-A/T (revolution sensor), shift solenoid valve A, B or vehicle speed sensor-MTR after cruise test?		
SAT934FA		
Yes or No		
Yes	▶	Check damaged circuit. Refer to "DTC P0720, P0750, P0755 or VHCL SPEED SEN-MTR", AT-117, 173, 179 or 205.
No	▶	GO TO 2.

2	CHECK SYMPTOM	
Check again.		
OK or NG		
OK	▶	Go to "8. Vehicle Cannot Be Started From D ₁ ", AT-231.
NG	▶	1. Perform TCM input/output signal inspection. 2. If NG, recheck TCM pin terminals for damage or loose connection with harness connector.

TROUBLE DIAGNOSES FOR SYMPTOMS

17. A/T Does Not Shift: D₄ → D₃, When Overdrive Control Switch ON → OFF

17. A/T Does Not Shift: D₄ → D₃, When Overdrive Control Switch ON → OFF

=NDAT0100

SYMPTOM:

A/T does not shift from D₄ to D₃ when changing overdrive control switch to OFF position.

1	CHECK OVERDRIVE SWITCH CIRCUIT
<p><input type="checkbox"/> With CONSULT-II Does "TCM INPUT SIGNALS" in "DATA MONITOR" show damage to overdrive control switch circuit?</p> <p><input checked="" type="checkbox"/> Without CONSULT-II Does self-diagnosis show damage to overdrive control switch circuit?</p>	
SAT367J	
Yes or No	
Yes	▶ Check overdrive control switch circuit. Refer to "DTC P0705", AT-103.
No	▶ Go to "10. A/T Does Not Shift: D ₂ → D ₃ ", AT-237.

GI

MA

EM

LC

EC

FE

AT

AX

SU

BR

ST

RS

BT

HA

SC

EL

IDX

TROUBLE DIAGNOSES FOR SYMPTOMS

18. A/T Does Not Shift: $D_3 \rightarrow 2_2$, When Selector Lever $D \rightarrow 2$ Position

18. A/T Does Not Shift: $D_3 \rightarrow 2_2$, When Selector Lever $D \rightarrow 2$ Position

=NDAT0101

SYMPTOM:

A/T does not shift from D_3 to 2_2 when changing selector lever from D to 2 position.

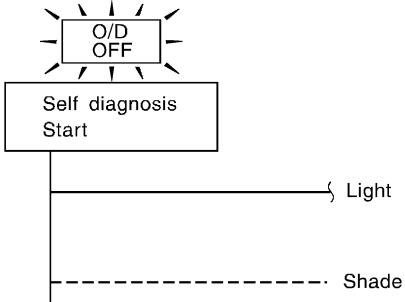
1	CHECK PARK/NEUTRAL POSITION (PNP) SWITCH CIRCUIT
<p><input type="checkbox"/> With CONSULT-II Does "TCM INPUT SIGNALS" in "DATA MONITOR" show damage to park/neutral position (PNP) switch circuit?</p> <p><input checked="" type="checkbox"/> Without CONSULT-II Does self-diagnosis show damage to park/neutral position (PNP) switch circuit?</p>	
	
SAT367J	
Yes or No	
Yes	▶ Check park/neutral position (PNP) switch circuit. Refer to "DTC P0705 PARK/NEUTRAL POSITION SWITCH", AT-103.
No	▶ Go to 9. A/T Does Not Shift: $D_1 \rightarrow D_2$ Or Does Not Kickdown: $D_4 \rightarrow D_2$, AT-234.

TROUBLE DIAGNOSES FOR SYMPTOMS



19. A/T Does Not Shift: 2₂ → 1₁, When Selector Lever 2 → 1 Position

19. A/T Does Not Shift: 2₂ → 1₁, When Selector Lever 2 → 1 Position

=NDAT0102

SYMPTOM:

A/T does not shift from 2₂ to 1₁ when changing selector lever from 2 to 1 position.

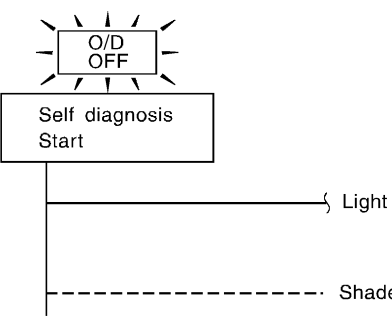
1	CHECK PARK/NEUTRAL POSITION (PNP) SWITCH CIRCUIT
<p> With CONSULT-II Does "TCM INPUT SIGNALS" in "DATA MONITOR" show damage to park/neutral position (PNP) switch circuit?</p> <p> Without CONSULT-II Does self-diagnosis show damage to park/neutral position (PNP) switch circuit?</p>	
	
SAT367J	
Yes or No	
Yes	▶ Check park/neutral position (PNP) switch circuit. Refer to "DTC P0705 PARK/NEUTRAL POSITION SWITCH", AT-103.
No	▶ GO TO 2.

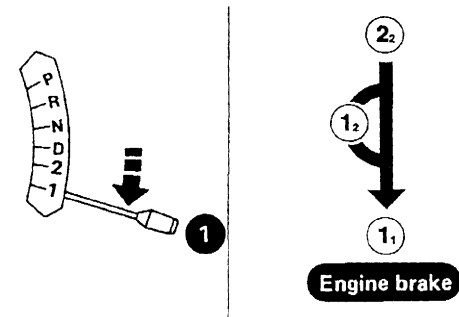
2	CHECK SYMPTOM
Check again.	
	
OK or NG	
OK	▶ INSPECTION END
NG	▶ <ol style="list-style-type: none"> 1. Perform TCM input/output signal inspection. 2. If NG, recheck TCM pin terminals for damage or loose connection with harness connector.

TROUBLE DIAGNOSES FOR SYMPTOMS

20. Vehicle Does Not Decelerate By Engine Brake

20. Vehicle Does Not Decelerate By Engine Brake

=NDAT0103

SYMPTOM:

Vehicle does not decelerate by engine brake when shifting from 2₂ (1₂) to 1₁.

1		CHECK SYMPTOM
Is 6. Vehicle Does Not Creep Backward In R Position OK?		
Yes or No		
Yes	▶	Go to "15. Engine Speed Does Not Return To Idle (Light Braking D ₄ → D ₃)", AT-248.
No	▶	Go to "6. Vehicle Does Not Creep Backward In R Position", AT-224.

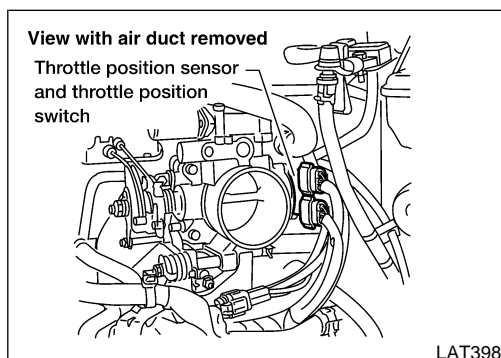
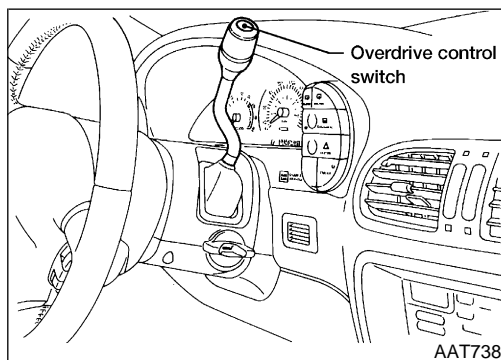
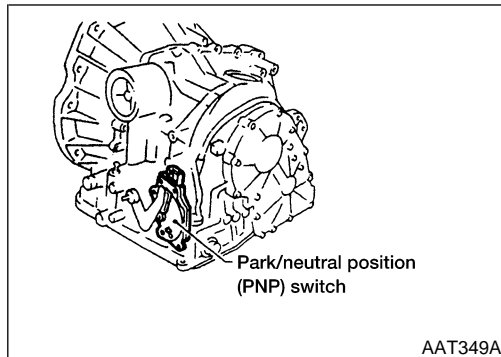

21. TCM Self-diagnosis Does Not Activate (PNP, Overdrive Control and Throttle Position Switches Circuit Checks)

NDAT0104

SYMPTOM:

O/D OFF indicator lamp does not come on in TCM self-diagnostic procedure even if the lamp circuit is good.

DESCRIPTION

NDAT0104S01

- Park/neutral position (PNP) switch
The park/neutral (PNP) switch assembly includes a transmission range switch. The transmission range switch detects the selector lever position and sends a signal to the TCM.
- Overdrive control switch
Detects the overdrive control switch position (ON or OFF) and sends a signal to the TCM.
- Throttle position switch
Consists of a wide open throttle position switch and a closed throttle position switch.
The wide open throttle position switch sends a signal to the TCM when the throttle valve is open at least 1/2 of the full throttle position. The closed throttle position switch sends a signal to the TCM when the throttle valve is fully closed.

TROUBLE DIAGNOSES FOR SYMPTOMS

21. TCM Self-diagnosis Does Not Activate (PNP, Overdrive Control and Throttle Position Switches Circuit Checks) (Cont'd)

DIAGNOSTIC PROCEDURE

=NDAT0104S02

NOTE:

The diagnostic procedure includes inspections for the overdrive control and throttle position switch circuits.

1	CHECK PARK/NEUTRAL POSITION (PNP) SWITCH CIRCUIT (With CONSULT-II)															
	<p>ⓐ With CONSULT-II</p> <ol style="list-style-type: none"> 1. Turn ignition switch to "ON" position. (Do not start engine.) 2. Select "TCM INPUT SIGNALS" in "DATA MONITOR" mode for "A/T" with CONSULT-II. 3. Read out P/N, R, D, 2 and 1 position switches moving selector lever to each position. Check that the signal of the selector lever position is indicated properly. 															
	<table border="1" style="margin: auto; border-collapse: collapse;"> <thead> <tr> <th colspan="2" style="text-align: center;">DATA MONITOR</th> </tr> <tr> <th style="text-align: center;">MONITORING</th> <th style="text-align: center;"></th> </tr> </thead> <tbody> <tr> <td style="text-align: center;">PN POSI SW</td> <td style="text-align: center;">OFF</td> </tr> <tr> <td style="text-align: center;">R POSITION SW</td> <td style="text-align: center;">OFF</td> </tr> <tr> <td style="text-align: center;">D POSITION SW</td> <td style="text-align: center;">OFF</td> </tr> <tr> <td style="text-align: center;">2 POSITION SW</td> <td style="text-align: center;">ON</td> </tr> <tr> <td style="text-align: center;">1 POSITION SW</td> <td style="text-align: center;">OFF</td> </tr> </tbody> </table>		DATA MONITOR		MONITORING		PN POSI SW	OFF	R POSITION SW	OFF	D POSITION SW	OFF	2 POSITION SW	ON	1 POSITION SW	OFF
DATA MONITOR																
MONITORING																
PN POSI SW	OFF															
R POSITION SW	OFF															
D POSITION SW	OFF															
2 POSITION SW	ON															
1 POSITION SW	OFF															
	SAT701J															
	OK or NG															
OK	▶	GO TO 3.														
NG	▶	<p>Check the following items:</p> <ul style="list-style-type: none"> ● Park/neutral position (PNP) switch (Refer to "Component Inspection", AT-261.) ● Harness for short or open between ignition switch and park/neutral position (PNP) switch (Main harness) ● Harness for short or open between park/neutral position (PNP) switch and TCM (Main harness) 														

GI

MA

EM

LC

EC

FE

AT

AX

SU

BR

ST

RS

BT

HA

SC

EL

IDX

TROUBLE DIAGNOSES FOR SYMPTOMS

21. TCM Self-diagnosis Does Not Activate (PNP, Overdrive Control and Throttle Position Switches Circuit Checks) (Cont'd)

2 CHECK PARK/NEUTRAL POSITION (PNP) SWITCH CIRCUIT (Without CONSULT-II)

⊗ Without CONSULT-II

1. Turn ignition switch to ON position. (Do not start engine.)
2. Check voltage between TCM terminals 26, 27, 34, 35, 36 and ground while moving selector lever through each position.

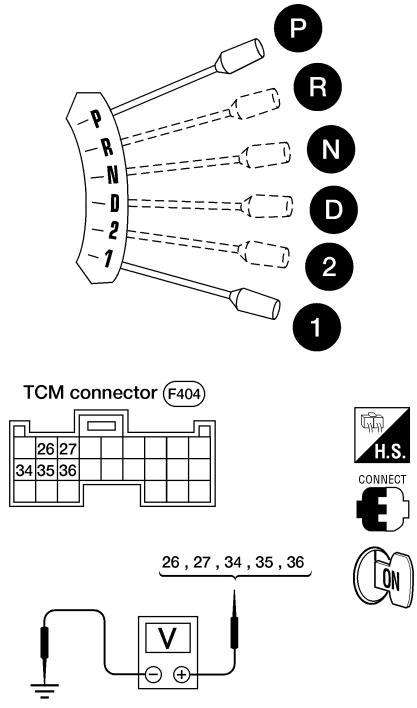

Voltage:
B: Battery voltage
0: 0V

AAT350A

Lever position	Terminal No.				
	36	35	34	27	26
P, N	B	0	0	0	0
R	0	B	0	0	0
D	0	0	B	0	0
2	0	0	0	B	0
1	0	0	0	0	B

MTBL0119

OK or NG

OK	▶	GO TO 4.
NG	▶	Check the following items: <ul style="list-style-type: none"> Park/neutral position (PNP) switch (Refer to "Component Inspection", AT-261.) Harness for short or open between ignition switch and park/neutral position (PNP) switch (Main harness) Harness for short or open between park/neutral position (PNP) switch and TCM (Main harness)

TROUBLE DIAGNOSES FOR SYMPTOMS

21. TCM Self-diagnosis Does Not Activate (PNP, Overdrive Control and Throttle Position Switches Circuit Checks) (Cont'd)

3	CHECK OVERDRIVE CONTROL SWITCH CIRCUIT (With CONSULT-II)															
<p>Ⓜ With CONSULT-II</p> <ol style="list-style-type: none"> 1. Turn ignition switch to "ON" position. (Do not start engine.) 2. Select "TCM INPUT SIGNALS" in "DATA MONITOR" mode for "AT" with CONSULT-II. 3. Read out "OVERDRIVE SWITCH". <p>Check the signal of the overdrive control switch is indicated properly. (Overdrive control switch "ON" displayed on CONSULT-II means overdrive "OFF".)</p> <table border="1" style="margin-left: auto; margin-right: auto; border-collapse: collapse; text-align: center;"> <thead> <tr> <th colspan="2">DATA MONITOR</th> </tr> <tr> <th>MONITORING</th> <th></th> </tr> </thead> <tbody> <tr> <td>ENGINE SPEED</td> <td>XXX rpm</td> </tr> <tr> <td>TURBINE REV</td> <td>XXX rpm</td> </tr> <tr> <td>OVERDRIVE SW</td> <td>ON</td> </tr> <tr> <td>PN POSI SW</td> <td>OFF</td> </tr> <tr> <td>R POSITION SW</td> <td>OFF</td> </tr> </tbody> </table> <p style="text-align: right; margin-right: 20px;">SAT645J</p> <p style="text-align: center;">OK or NG</p>			DATA MONITOR		MONITORING		ENGINE SPEED	XXX rpm	TURBINE REV	XXX rpm	OVERDRIVE SW	ON	PN POSI SW	OFF	R POSITION SW	OFF
DATA MONITOR																
MONITORING																
ENGINE SPEED	XXX rpm															
TURBINE REV	XXX rpm															
OVERDRIVE SW	ON															
PN POSI SW	OFF															
R POSITION SW	OFF															
OK	▶	GO TO 5.														
NG	▶	<p>Check the following items:</p> <ul style="list-style-type: none"> ● Overdrive control switch (Refer to "Component Inspection", AT-261.) ● Harness for short or open between TCM and overdrive control switch (Main harness) ● Harness of ground circuit for overdrive control switch (Main harness) for short or open 														

GI
 MA
 EM
 LC
 EC
 FE
AT
 AX
 SU
 BR
 ST
 RS
 BT
 HA
 SC
 EL
 IDX

TROUBLE DIAGNOSES FOR SYMPTOMS

21. TCM Self-diagnosis Does Not Activate (PNP, Overdrive Control and Throttle Position Switches Circuit Checks) (Cont'd)

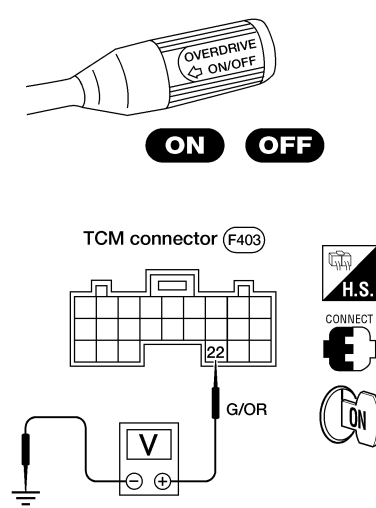
4	CHECK OVERDRIVE CONTROL SWITCH CIRCUIT (Without CONSULT-II)						
<p>⊗ Without CONSULT-II</p> <ol style="list-style-type: none"> 1. Turn ignition switch to ON position. (Do not start engine.) 2. Check voltage between TCM terminal 22 and ground when overdrive control switch is ON and OFF. 							
							
AAT397A							
<table border="1" style="margin: auto; border-collapse: collapse;"> <thead> <tr> <th style="padding: 5px;">Switch position</th> <th style="padding: 5px;">Voltage</th> </tr> </thead> <tbody> <tr> <td style="text-align: center; padding: 5px;">ON</td> <td style="text-align: center; padding: 5px;">Battery voltage</td> </tr> <tr> <td style="text-align: center; padding: 5px;">OFF</td> <td style="text-align: center; padding: 5px;">1V or less</td> </tr> </tbody> </table>		Switch position	Voltage	ON	Battery voltage	OFF	1V or less
Switch position	Voltage						
ON	Battery voltage						
OFF	1V or less						
MTBL0106							
OK or NG							
OK	▶ GO TO 6.						
NG	<p>Check the following items:</p> <ul style="list-style-type: none"> ● Overdrive control switch (Refer to "Component Inspection", AT-261.) ● Harness for short or open between TCM and overdrive control switch (Main harness) ● Harness of ground circuit for overdrive control switch (Main harness) for short or open 						

TROUBLE DIAGNOSES FOR SYMPTOMS

21. TCM Self-diagnosis Does Not Activate (PNP, Overdrive Control and Throttle Position Switches Circuit Checks) (Cont'd)

5	CHECK THROTTLE POSITION SWITCH CIRCUIT (With CONSULT-II)															
<p>Ⓜ With CONSULT-II</p> <ol style="list-style-type: none"> 1. Turn ignition switch to ON position. (Do not start engine.) 2. Select "TCM INPUT SIGNALS" in "DATA MONITOR" mode for "A/T" with CONSULT-II. 3. Read out "CLOSED THL/SW" and "W/O THRL/P-SW" depressing and releasing accelerator pedal. Check the signal of throttle position switch is indicated properly. 																
<table border="1" style="margin: auto; border-collapse: collapse;"> <thead> <tr> <th colspan="2">DATA MONITOR</th> </tr> <tr> <th>MONITORING</th> <th></th> </tr> </thead> <tbody> <tr> <td>POWERSHIFT SW</td> <td>OFF</td> </tr> <tr> <td>CLOSED THL/SW</td> <td>OFF</td> </tr> <tr> <td>W/O THRL/P-SW</td> <td>OFF</td> </tr> <tr> <td>HOLD SW</td> <td>OFF</td> </tr> <tr> <td>BRAKE SW</td> <td>ON</td> </tr> </tbody> </table>			DATA MONITOR		MONITORING		POWERSHIFT SW	OFF	CLOSED THL/SW	OFF	W/O THRL/P-SW	OFF	HOLD SW	OFF	BRAKE SW	ON
DATA MONITOR																
MONITORING																
POWERSHIFT SW	OFF															
CLOSED THL/SW	OFF															
W/O THRL/P-SW	OFF															
HOLD SW	OFF															
BRAKE SW	ON															
SAT702J																
<table border="1" style="margin: auto; border-collapse: collapse;"> <thead> <tr> <th rowspan="2">Accelerator pedal condition</th> <th colspan="2">Data monitor</th> </tr> <tr> <th>CLOSED THL/SW</th> <th>W/O THRL/P-SW</th> </tr> </thead> <tbody> <tr> <td>Released</td> <td>ON</td> <td>OFF</td> </tr> <tr> <td>Fully depressed</td> <td>OFF</td> <td>ON</td> </tr> </tbody> </table>			Accelerator pedal condition	Data monitor		CLOSED THL/SW	W/O THRL/P-SW	Released	ON	OFF	Fully depressed	OFF	ON			
Accelerator pedal condition	Data monitor															
	CLOSED THL/SW	W/O THRL/P-SW														
Released	ON	OFF														
Fully depressed	OFF	ON														
MTBL0011																
OK or NG																
OK	▶	GO TO 7.														
NG	▶	<p>Check the following items:</p> <ul style="list-style-type: none"> ● Throttle position switch — Refer to "Component Inspection", AT-261. ● Harness for short or open between ignition switch and throttle position switch (Main harness) ● Harness for short or open between throttle position switch and TCM (Main harness) 														

GI

MA

EM

LC

EC

FE

AT

AX

SU

BR

ST

RS

BT

HA

SC

EL

IDX

TROUBLE DIAGNOSES FOR SYMPTOMS

21. TCM Self-diagnosis Does Not Activate (PNP, Overdrive Control and Throttle Position Switches Circuit Checks) (Cont'd)

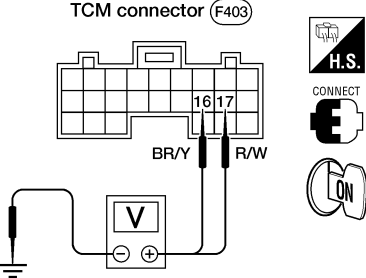
6	CHECK THROTTLE POSITION SWITCH CIRCUIT (Without CONSULT-II)												
<p>⊗ Without CONSULT-II</p> <p>1. Turn ignition switch to ON position. (Do not start engine.)</p> <p>2. Check voltage between TCM terminals 16, 17 and ground while depressing, and releasing accelerator pedal slowly. (After warming up engine)</p>													
													
AAT383A													
<table border="1" style="margin: auto;"> <thead> <tr> <th rowspan="2">Accelerator pedal condition</th> <th colspan="2">Voltage</th> </tr> <tr> <th>Terminal No. 16</th> <th>Terminal No. 17</th> </tr> </thead> <tbody> <tr> <td>Released</td> <td>Battery voltage</td> <td>1V or less</td> </tr> <tr> <td>Fully depressed</td> <td>1V or less</td> <td>Battery voltage</td> </tr> </tbody> </table>			Accelerator pedal condition	Voltage		Terminal No. 16	Terminal No. 17	Released	Battery voltage	1V or less	Fully depressed	1V or less	Battery voltage
Accelerator pedal condition	Voltage												
	Terminal No. 16	Terminal No. 17											
Released	Battery voltage	1V or less											
Fully depressed	1V or less	Battery voltage											
MTBL0120													
OK or NG													
OK	▶	GO TO 7.											
NG	▶	<p>Check the following items:</p> <ul style="list-style-type: none"> ● Throttle position switch. Refer to "Component Inspection", AT-261. ● Harness for short or open between ignition switch and throttle position switch (Main harness) ● Harness for short or open between throttle position switch and TCM (Main harness) 											

7	CHECK DTC	
Perform Diagnostic procedure, AT-255.		
OK or NG		
OK	▶	INSPECTION END
NG	▶	<p>1. Perform TCM input/output signal inspection.</p> <p>2. If NG, recheck TCM pin terminals for damage or loose connection with harness connector.</p>

TROUBLE DIAGNOSES FOR SYMPTOMS

21. TCM Self-diagnosis Does Not Activate (PNP, Overdrive Control and Throttle Position Switches Circuit Checks) (Cont'd)

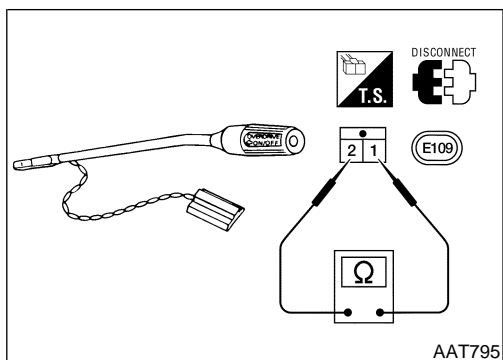

COMPONENT INSPECTION

=NDAT0104S03

Overdrive Control Switch

NDAT0104S0301

- Check continuity between two terminals.

Switch position	Continuity
ON	No
OFF	Yes

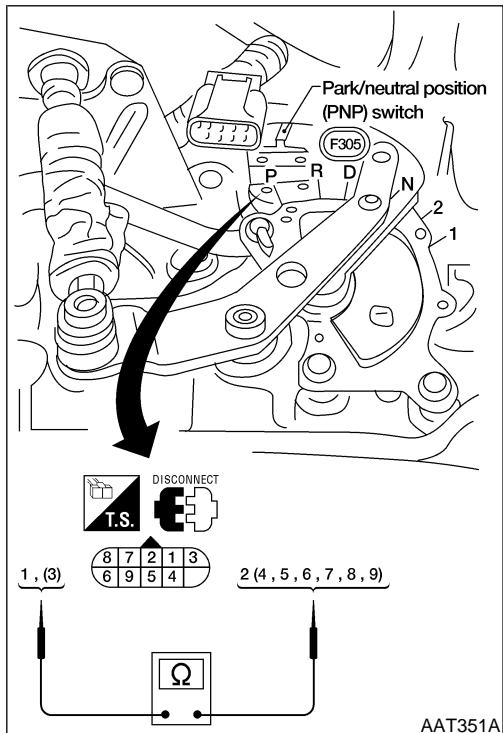

Park/Neutral Position (PNP) Switch

NDAT0104S0302

- Check continuity between terminals 1 and 2 and between terminals 3 and 4, 5, 6, 7, 8, 9 while moving manual shaft through each position.

Lever position	Terminal No.	
P	3 — 7	1 — 2
R	3 — 8	
N	3 — 9	1 — 2
D	3 — 6	
2	3 — 5	
1	3 — 4	

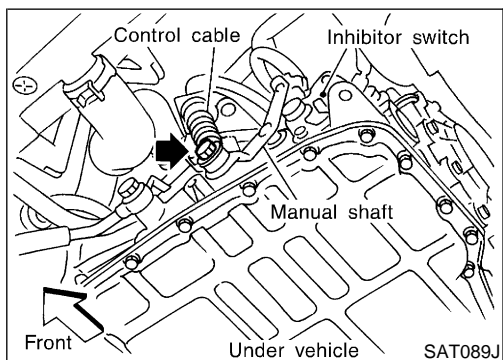

- If NG, check again with manual control cable disconnected from manual shaft of A/T assembly. Refer to step 1.
- If OK on step 2, adjust manual control cable. Refer to AT-272.
- If NG on step 2, remove park/neutral position (PNP) switch from A/T and check continuity of park/neutral position (PNP) switch terminals. Refer to step 1.
- If OK on step 4, adjust park/neutral position (PNP) switch. Refer to AT-271.
- If NG on step 4, replace park/neutral position (PNP) switch.

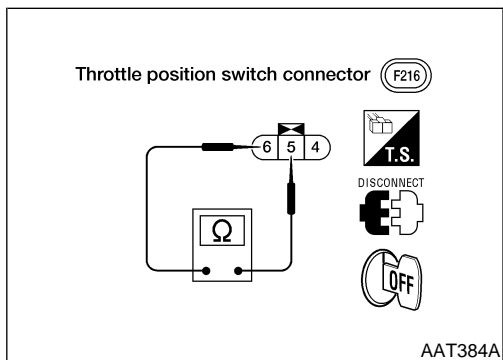

Throttle Position Switch

NDAT0104S0303

Closed throttle position switch (idle position)

- Check continuity between terminals 5 and 6.

Accelerator pedal condition	Continuity
Released	Yes
Depressed	No

- To adjust closed throttle position switch, refer to **EC-87**, "Basic Inspection".

GI

MA

EM

LC

EC

FE

AT

AX

SU

BR

ST

RS

BT

HA

SC

EL

IDX

TROUBLE DIAGNOSES FOR SYMPTOMS

21. TCM Self-diagnosis Does Not Activate (PNP, Overdrive Control and Throttle Position Switches Circuit Checks) (Cont'd)

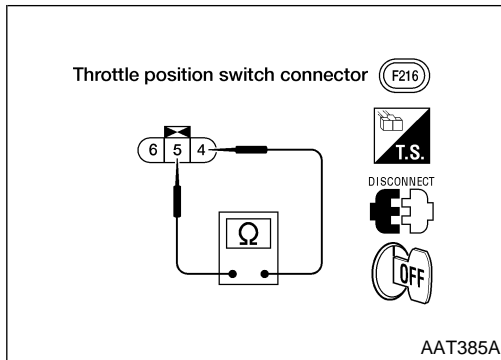

Wide open throttle position switch

- Check continuity between terminals 4 and 5.

Accelerator pedal condition	Continuity
Released	No
Depressed	Yes

A/T SHIFT LOCK SYSTEM

Description

Description

NDAT0105

- The mechanical key interlock mechanism also operates as a shift lock:
With the key switch turned to ON, the selector lever cannot be shifted from P (parking) to any other position unless the brake pedal is depressed.
With the key removed, the selector lever cannot be shifted from P to any other position.
The key cannot be removed unless the selector lever is placed in P.
- The shift lock and key interlock mechanisms are controlled by the ON-OFF operation of the shift lock solenoid and by the operation of the rotator and slider located inside the key cylinder, respectively.

GI

MA

EM

LC

EC

FE

AT

AX

SU

BR

ST

RS

BT

HA

SC

EL

IDX

AT SHIFT LOCK SYSTEM

Wiring Diagram — SHIFT —

Wiring Diagram — SHIFT —

NDAT0108

AT-SHIFT-01

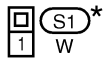
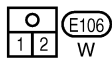
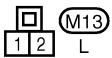
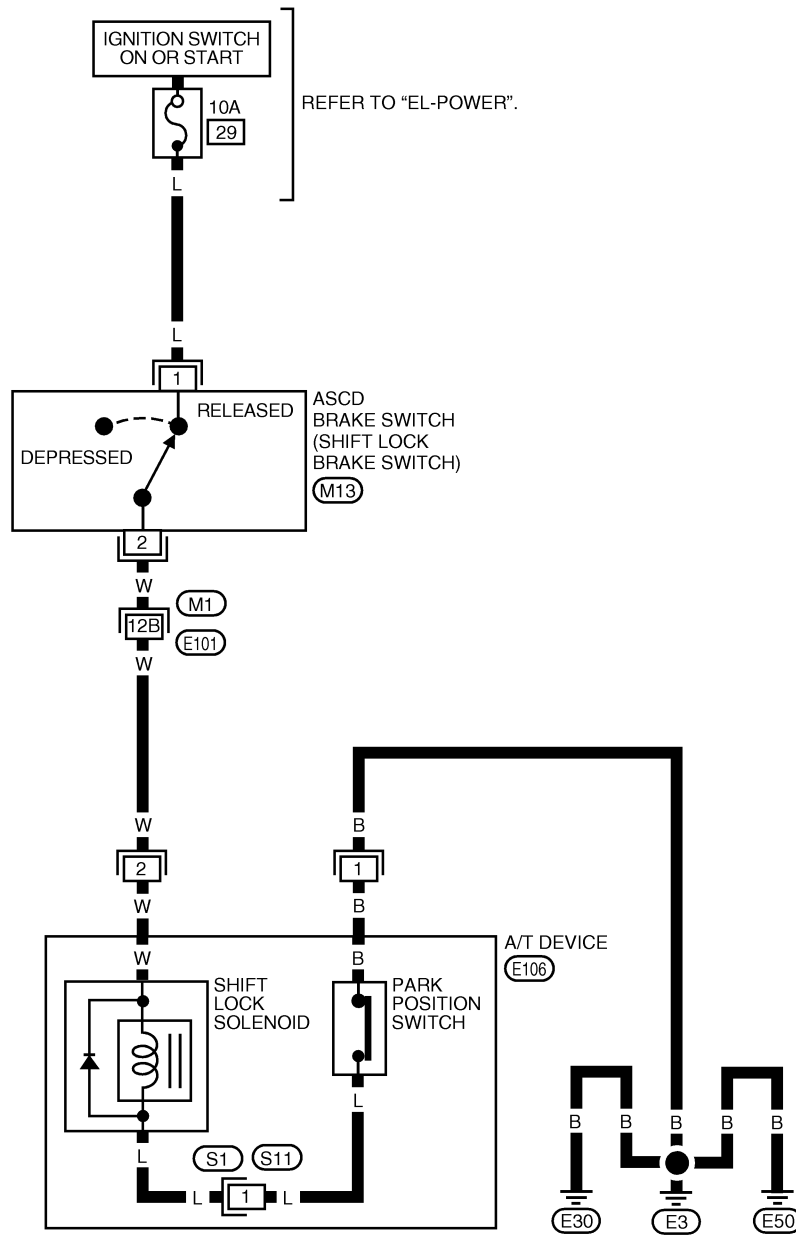

REFER TO THE FOLLOWING.
 (M1), (E101) - SUPER MULTIPLE
 JUNCTION (SMJ)

* : THIS CONNECTOR IS NOT SHOWN IN "HARNESS LAYOUT" OF EL SECTION.

WAT327

A/T SHIFT LOCK SYSTEM

Shift Lock System Electrical Parts Location

Shift Lock System Electrical Parts Location

NDAT0106

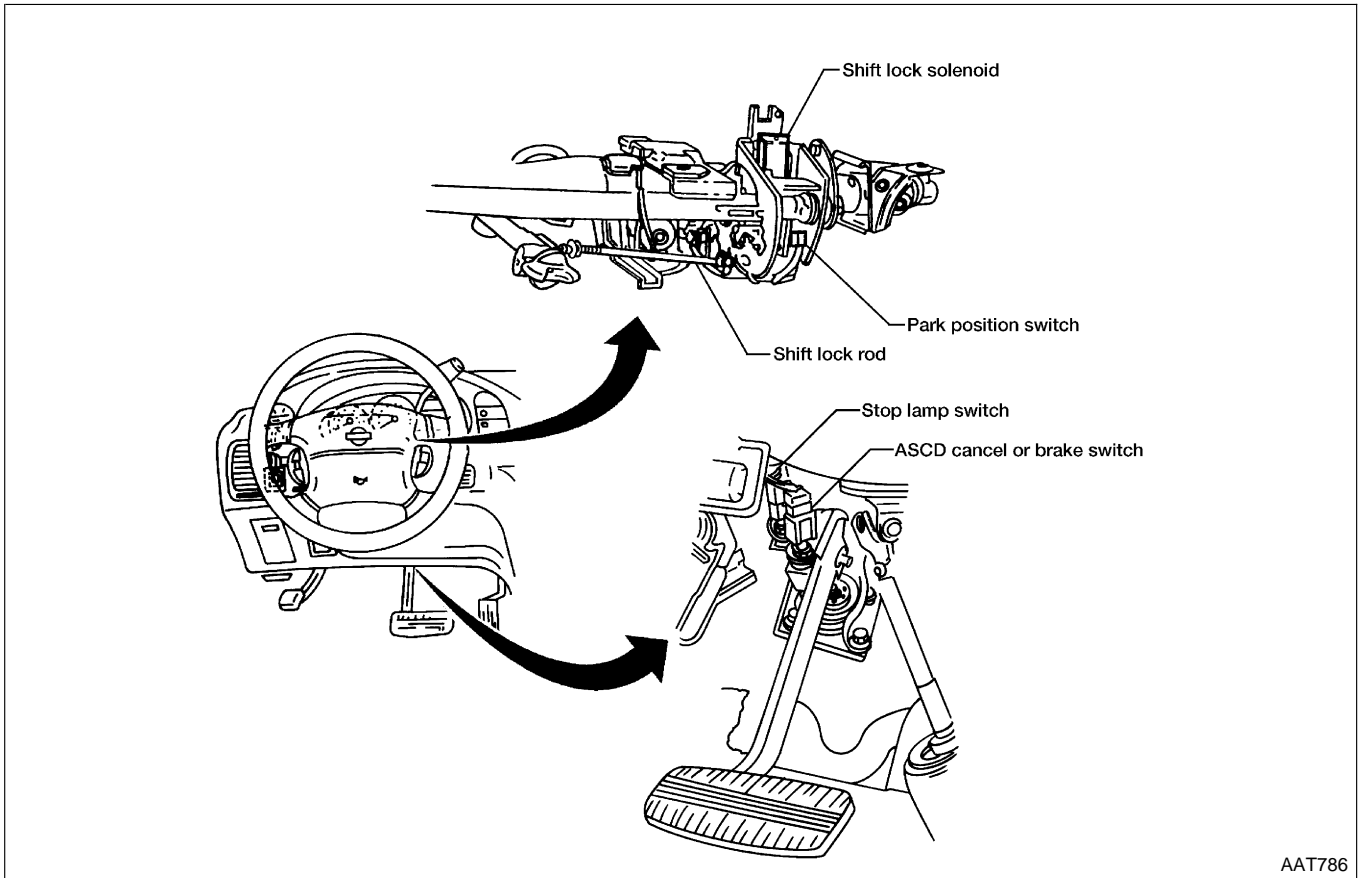

AAT786

Removal

SHIFT LOCK SOLENOID

NDAT0107

NDAT0107S01

1. Remove lower instrument cover LH and knee protector.
2. Remove heater duct.
3. Remove steering column covers.
4. Disconnect position indicator wire.
5. Remove four nuts attaching steering column.
6. Disconnect shift lock rod.
7. Remove shift control cable.
8. Disconnect ignition switch connector.
9. Remove two bolts attaching shift control tube and remove shift control tube.
10. Remove two screws from shift lock solenoid and two screws from park position switch.

SHIFT LOCK ROD

NDAT0107S02

1. Turn ignition key to ACC position.
2. Unlock slider by squeezing lock tabs.
3. Remove shift lock rod from key interlock rod.
- For removal of key interlock rod, refer to **ST-13**, "Disassembly and Assembly".

A/T SHIFT LOCK SYSTEM

Diagnostic Procedure

Diagnostic Procedure

NDAT0109

SYMPTOM 1:

- Selector lever cannot be moved from P position with key in ON position and brake pedal applied.
- Selector lever can be moved from P position with key in ON position and brake pedal released.
- Selector lever can be moved from P position when key is removed from key cylinder.

SYMPTOM 2:

Ignition key cannot be removed when selector lever is set to P position. It can be removed when selector lever is set to any position except P.

1	CHECK KEY INTERLOCK ROD	
Check selector lever position for damage.		
OK or NG		
OK	▶	GO TO 2.
NG	▶	Check selector lever. Refer to "ON-VEHICLE SERVICE — Park/Neutral Position (PNP) Switch and Control Cable Adjustment", AT-271, AT-272.

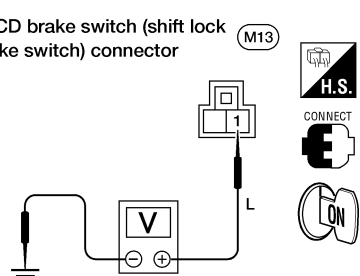
2	CHECK POWER SOURCE	
<p>1. Turn ignition switch to ON position. (Do not start engine.)</p> <p>2. Check voltage between A/T shift lock switch (ASCD brake switch) harness terminal 1 and ground.</p>		
		
<p>Voltage: Battery voltage</p>		
OK or NG		
OK	▶	GO TO 3.
NG	▶	<p>Check the following items:</p> <ol style="list-style-type: none"> 1. Harness for short or open between battery and ASCD brake switch (Shift lock brake switch) harness terminal 1 2. Fuse 3. Ignition switch (Refer to <i>EL-17</i>, "IGNITION POWER SUPPLY—IGNITION SW. IN ON AND/OR START".)

AAT398A

A/T SHIFT LOCK SYSTEM

Diagnostic Procedure (Cont'd)

3	CHECK INPUT SIGNAL A/T DEVICE	<p>Turn ignition switch to ON position. (Do not start engine.)</p> <ul style="list-style-type: none"> Check voltage between A/T device harness terminal 2 and ground. <div style="text-align: center;"> </div> <div style="text-align: right; margin-top: 10px;">AAT399A</div> <table border="1" style="margin: 10px auto; border-collapse: collapse;"> <tr> <td style="padding: 2px;">Brake pedal</td> <td style="padding: 2px;">Voltage</td> </tr> <tr> <td style="padding: 2px;">Depressed</td> <td style="padding: 2px;">0V</td> </tr> <tr> <td style="padding: 2px;">Released</td> <td style="padding: 2px;">Battery voltage</td> </tr> </table> <div style="text-align: right; margin-top: 10px;">MTBL0107</div> <p style="text-align: center; margin-top: 10px;">OK or NG</p>	Brake pedal	Voltage	Depressed	0V	Released	Battery voltage	GI MA EM LC EC FE AT
Brake pedal	Voltage								
Depressed	0V								
Released	Battery voltage								
OK	▶	GO TO 4.							
NG	▶	<p>Check the following items:</p> <ol style="list-style-type: none"> Harness for short or open between A/T device harness connector 2 and ASCD brake switch (Shift lock brake switch) harness connector 2 ASCD brake switch (Shift lock brake switch) (Refer to "Component Check", AT-269.) 	AX SU						

4	CHECK GROUND CIRCUIT	<ol style="list-style-type: none"> Turn ignition switch to OFF position. Disconnect A/T device harness connector. Check continuity between A/T device harness terminal 1 and ground. <div style="text-align: center;"> </div> <div style="text-align: right; margin-top: 10px;">AAT400A</div> <p style="color: blue; margin-top: 10px;">Continuity should exist.</p> <p>If OK, check harness for short to ground and short to power.</p> <p style="text-align: center; margin-top: 10px;">OK or NG</p>	BR ST RS BT HA SC EL
OK	▶	GO TO 5.	
NG	▶	Repair open circuit or short to ground or short to power in harness or connectors.	IDX

5	CHECK PARK POSITION SWITCH	<p>Refer to "Component Check", AT-269.</p> <p style="text-align: center; margin-top: 10px;">OK or NG</p>	
OK	▶	GO TO 6.	
NG	▶	Replace park position switch.	

A/T SHIFT LOCK SYSTEM

Diagnostic Procedure (Cont'd)

6	CHECK SHIFT LOCK SOLENOID	
Refer to "Component Check", AT-269.		
OK or NG		
OK	▶	GO TO 7.
NG	▶	Replace shift lock solenoid.

7	CHECK SHIFT LOCK OPERATION	
1. Reconnect shift lock harness connector. 2. Turn ignition switch from OFF to ON position. (Do not start engine.) 3. Recheck shift lock operation.		
OK or NG		
OK	▶	INSPECTION END
NG	▶	1. Perform A/T device input/output signal inspection test. 2. If NG, recheck harness connector connection.

Installation and Adjustment SHIFT LOCK ROD

NDAT0110

NDAT0110S01

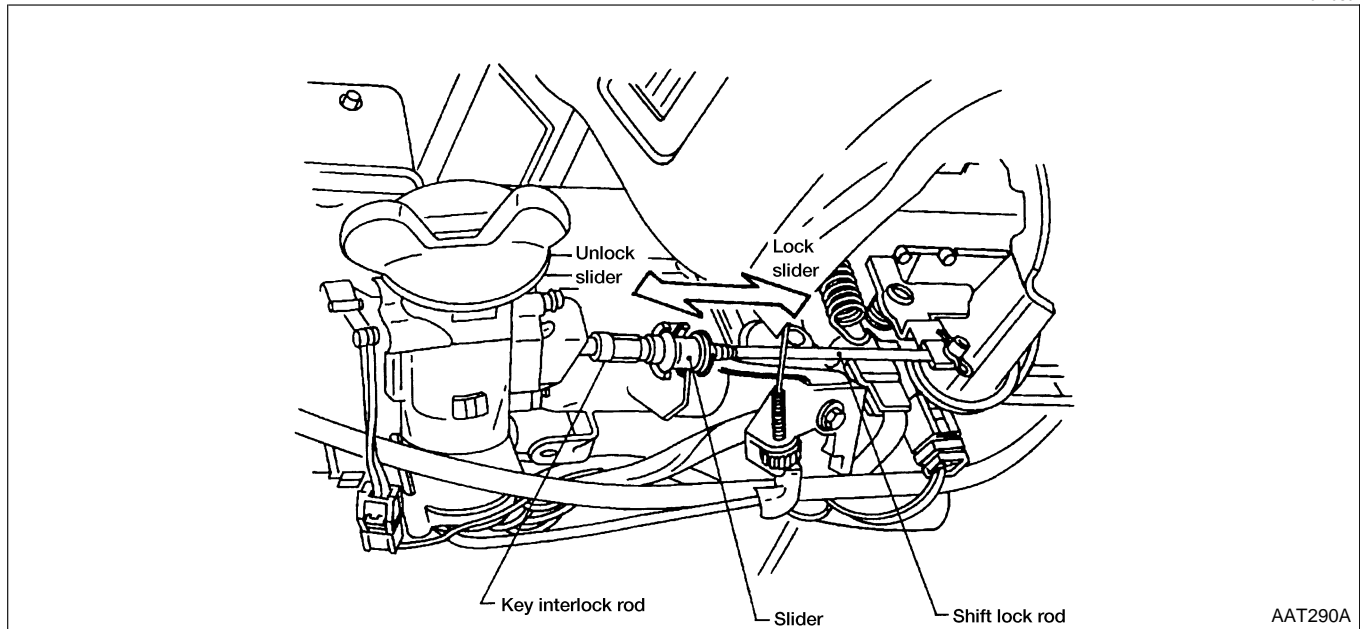

AAT290A

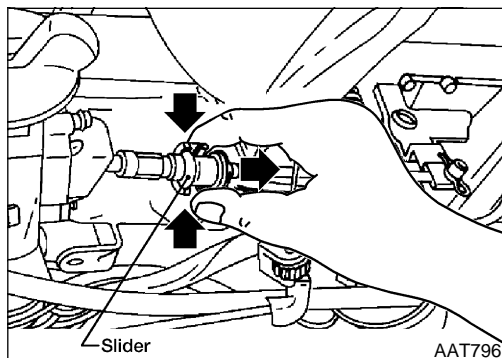

AAT796

1. Place selector lever in Park "P" position.
 2. Turn ignition key to LOCK position.
 3. Insert shift lock rod into slider.
 4. Grab key interlock rod and push toward shift lock rod to adjust.
- Do not hold shift lock rod.**
5. Lock slider into position.
 6. Test shift lock operation.

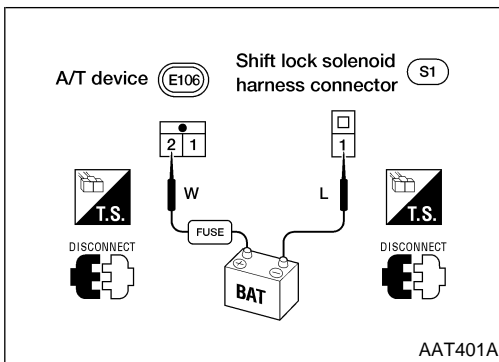

Component Check

SHIFT LOCK SOLENOID

NDAT0111

NDAT0111S01

- Check operation by applying battery voltage to A/T device harness terminal 2 and shift lock solenoid harness terminal 1.

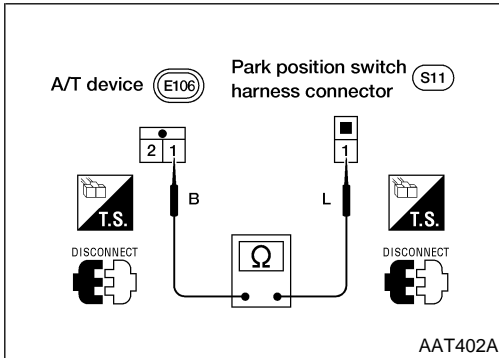

PARK POSITION SWITCH

NDAT0111S02

- Check continuity between A/T device harness terminal 1 and park position switch harness terminal 2.

Condition	Continuity
When selector lever is set in "P" position and selector lever button is released	Yes
Except above	No

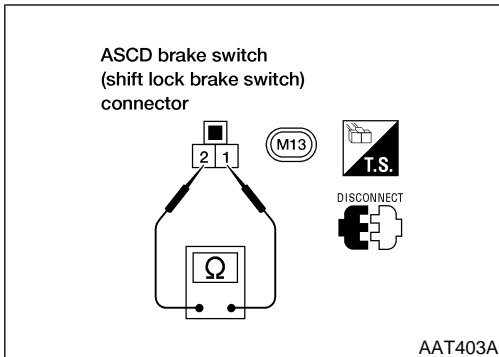

ASCD BRAKE SWITCH (SHIFT LOCK BRAKE SWITCH)

NDAT0111S03

- Check continuity between terminals 1 and 2.

Condition	Continuity
When brake pedal is depressed	No
When brake pedal is released	Yes

Check ASCD brake switch (shift lock brake switch) after adjusting brake pedal — refer to *BR-13*, "Adjustment".

GI

MA

EM

LC

EC

FE

AT

AX

SU

BR

ST

RS

BT

HA

SC

EL

IDX

ON-VEHICLE SERVICE

Control Valve Assembly and Accumulators

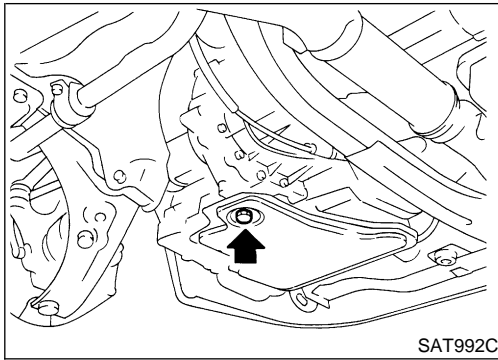

Control Valve Assembly and Accumulators REMOVAL

NDAT0112

NDAT0112S01

1. Drain ATF from transaxle.
2. Remove oil pan and gasket.
 - **Always replace oil pan bolts as they are self-sealing bolts.**

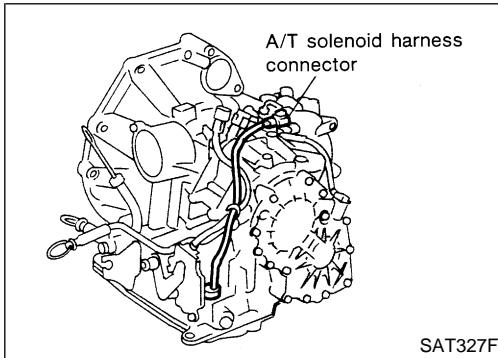

3. Disconnect A/T solenoid harness connector.

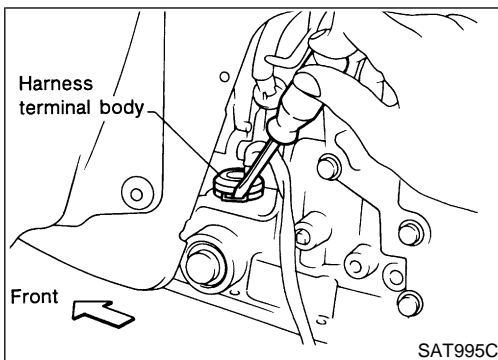

4. Remove snap ring from terminal cord assembly harness terminal body.
5. Remove terminal cord assembly harness from transmission case by pushing on terminal body.

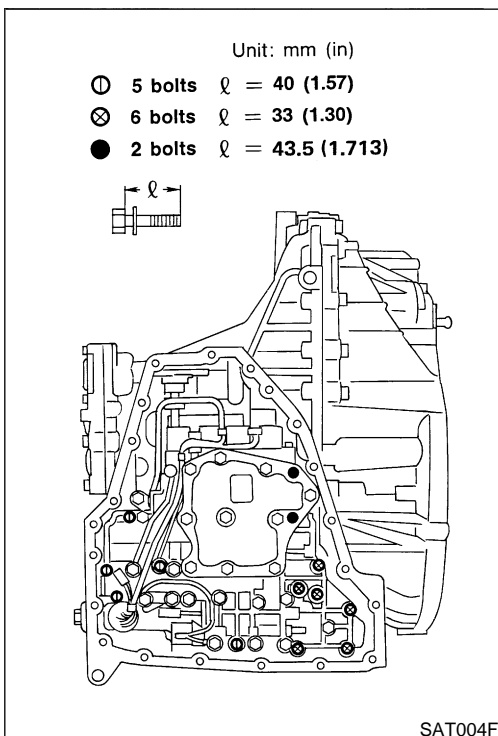

6. Remove control valve assembly by removing fixing bolts I, X and ●.

Bolt length, number and location are shown in the illustration.

- **Be careful not to drop manual valve and servo release accumulator return spring.**
7. Disassemble and inspect control valve assembly if necessary. Refer to "Control Valve Assembly", AT-302.

ON-VEHICLE SERVICE

Control Valve Assembly and Accumulators (Cont'd)

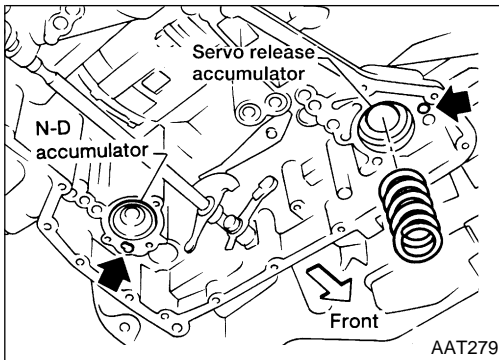

8. Remove servo release and N-D accumulators by applying compressed air if necessary.
- Hold each piston with a rag.

GI

MA

EM

LC

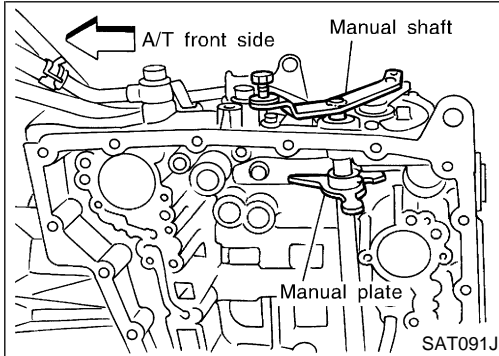

INSTALLATION

- Set manual shaft in Neutral, then align manual plate with groove in manual valve.
- After installing control valve assembly, make sure that selector lever can be moved to all positions.

NDAT0112S02

EC

FE

AT

AX

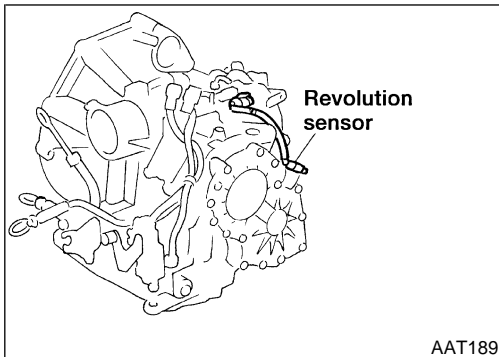

Revolution Sensor Replacement

1. Remove under cover.
 2. Remove revolution sensor from A/T.
 3. Reinstall any part removed.
- Always use new sealing parts.

NDAT0113

SU

BR

ST

RS

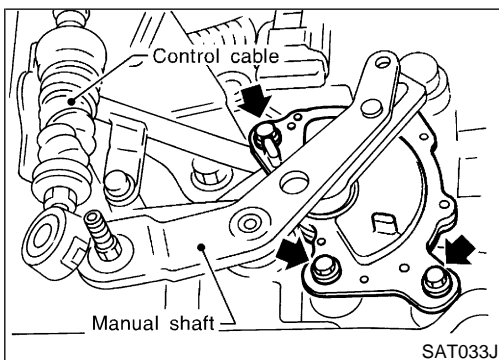

Park/Neutral Position (PNP) Switch Adjustment

1. Remove control cable from manual shaft.
2. Set manual shaft in N position.
3. Loosen park/neutral position (PNP) switch fixing bolts.

NDAT0114

BT

HA

SC

EL

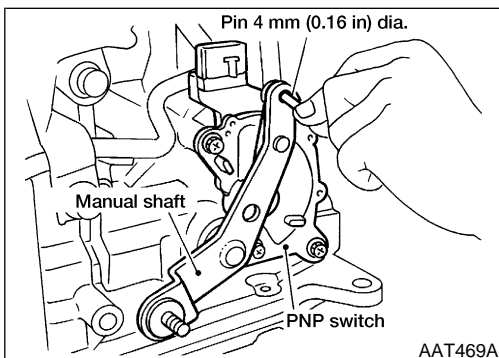

4. Insert pin into adjustment holes in both park/neutral position (PNP) switch and manual shaft as near vertical as possible.
5. Reinstall any part removed.
6. Check continuity of park/neutral position (PNP) switch. Refer to "Component Inspection", AT-109.

IDX

ON-VEHICLE SERVICE

Control Cable Adjustment

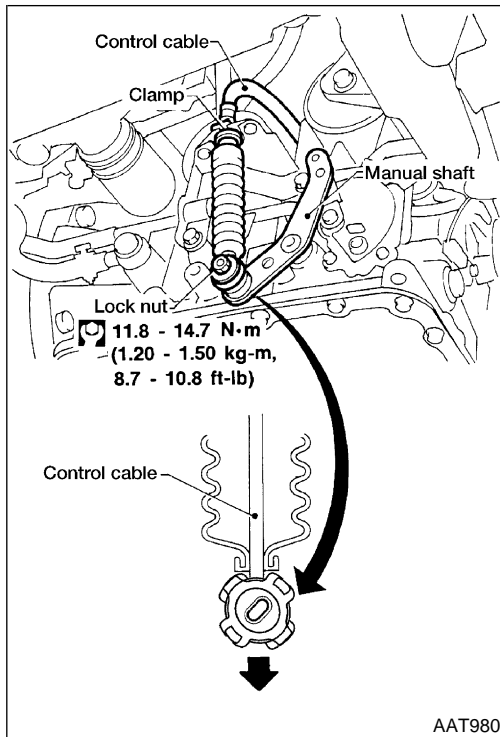

Control Cable Adjustment

NDAT0115

Move selector lever from the P position to the 1 position. You should be able to feel the detents in each position. If the detents cannot be felt or the pointer indicating the position is improperly aligned, the control cable needs adjustment.

1. Place selector lever in P position.
2. Loosen control cable lock nut and place manual shaft in P position.

CAUTION:

Turn wheels more than 1/4 rotations and apply the park lock.

3. Push control cable in the direction of the arrow shown in the illustration by specified force.

Specified force: 4.9 - 9.8 N (0.5 - 1.0 kg, 1.1 - 2.2 lb)

4. Tighten control cable lock nut.
 5. Move selector lever from P to 1 position again. Make sure that selector lever moves smoothly.
- Make sure that the starter operates when the selector lever is placed in the N or P position.
 - Make sure that the transmission is locked properly when the selector lever is placed in the P position.

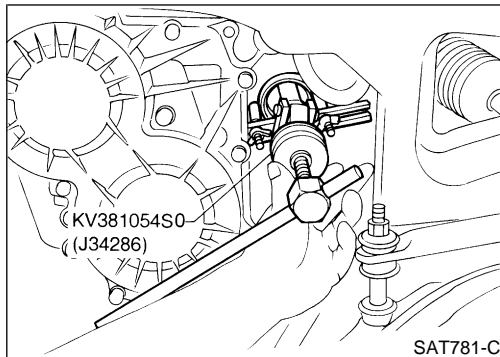

Differential Side Oil Seal Replacement

NDAT0116

1. Remove drive shaft assembly. Refer to AX-10, "Removal".
2. Remove oil seal.

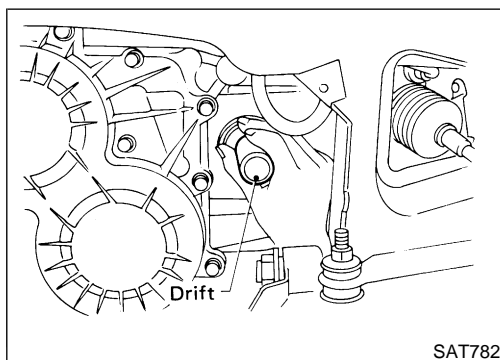

3. Install oil seal.
- Apply ATF before installing.

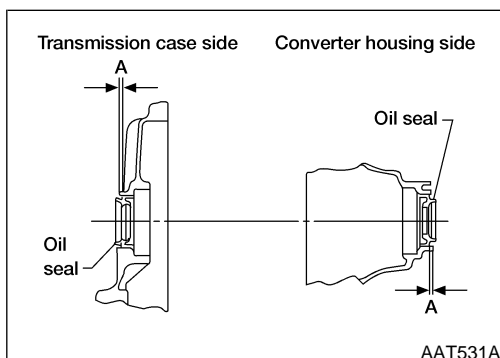

- Install oil seals so dimension A is within specification
A: -0.5 mm (-0.02 in) to 0.5 (0.02 in)
4. Reinstall any part removed.

REMOVAL AND INSTALLATION

NDAT0117

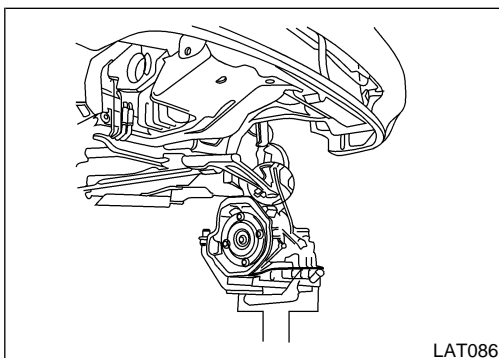
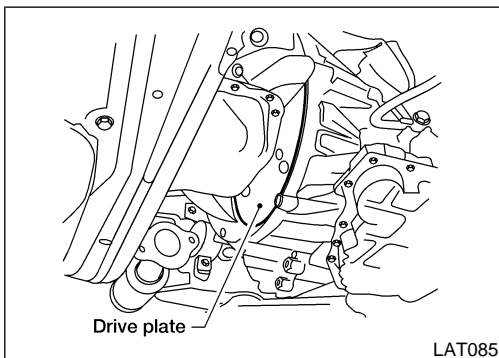
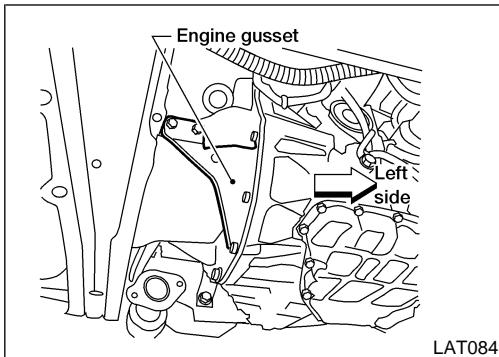
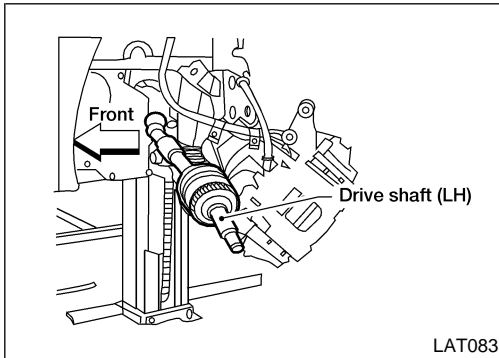
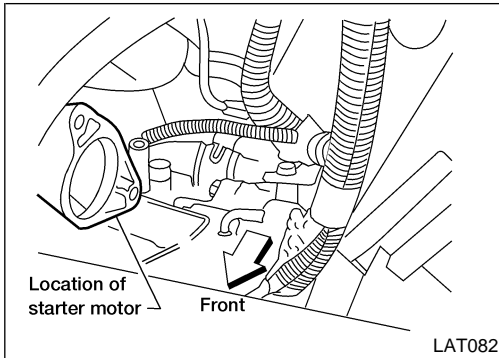

Removal

CAUTION:

When removing the transaxle assembly from engine, first remove the crankshaft position sensor (OBD) from the assembly.

Be careful not to damage sensor edge.

1. Remove battery and battery tray.
2. Remove resonator.
3. Disconnect terminal cord assembly harness connector, vacuum lines and starter motor.
4. Drain ATF.
5. Remove drive shafts. Refer to **AX-10**, "REMOVAL".
6. Remove A/T cooler hose and control cable.
7. Remove front exhaust manifold.
8. Remove crankshaft position sensor (OBD) from transaxle.
9. Remove engine gusset and torque converter under cover. Refer to **EM-44**, "Engine Mounting".
10. Remove bolts from drive plate for torque converter.
 - Rotate crankshaft for access to securing bolts.
11. Support transaxle
12. Remove front mounting.
13. Remove rear mounting.

14. Remove bolts fixing A/T to engine.
15. Lower transaxle while supporting it with a jack.

GI

MA

EM

LC

EC

FE

AT

AX

SU

BR

ST

RS

BT

HA

SC

EL

IDX

REMOVAL AND INSTALLATION

Installation

NDAT0118

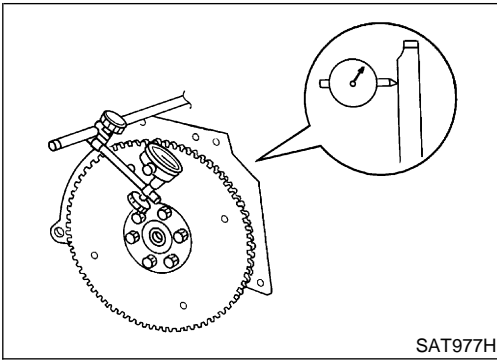

SAT977H

Installation

- Drive plate runout

CAUTION:
Do not allow any magnetic materials to contact the ring gear teeth.

Maximum allowable runout:
Refer to EM-49, "Inspection".

If this runout is out of allowance, replace drive plate and ring gear.

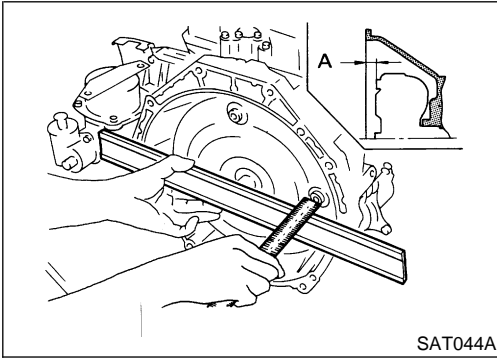

SAT044A

- When connecting torque converter to transaxle, measure distance "A" to be certain that they are correctly assembled.

Distance "A":
14 mm (0.55 in) or more

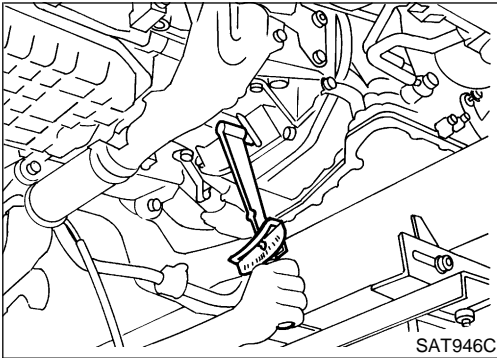

SAT946C

- Install bolts fixing converter to drive plate.
- **With converter installed, rotate crankshaft several turns to check that transaxle rotates freely without binding.**

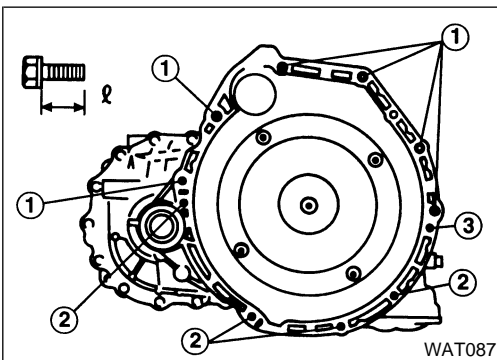

WAT087

- Tighten bolts securing transaxle.
- Tighten LH mounting bracket bolts to the specified torque. Refer to **EM-43, "ENGINE REMOVAL"**.
- Tighten rear plate cover bolts to the specified torque. Refer to **EM-14, "OIL PAN"**.

Bolt or Nut		Tightening torque N·m (kg·m, ft·lb)	ℓ mm (in)
Bolt	1	39 - 49 (4.0 - 5.0, 29 - 36)	60 (2.36)
	2	30 - 40 (3.1 - 4.1, 22 - 30)	27.5 (1.08)
Nut	3*	30 - 40 (3.1 - 4.1, 22 - 30)	25 (0.98)

*: Stud bolt is used.

- Reinstall any part removed.

REMOVAL AND INSTALLATION

Installation (Cont'd)

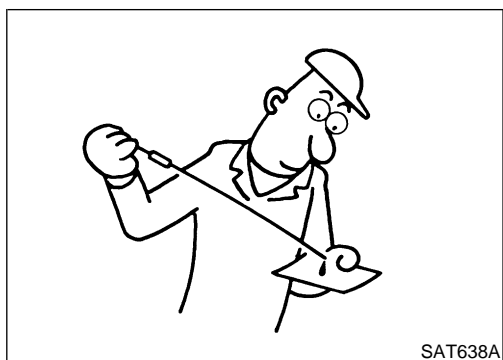

- Check fluid level in transaxle.
- Move selector lever through all positions to be sure that transaxle operates correctly.
With parking brake applied, rotate engine at idling. Move selector lever through N to D, to 2, to 1 and to R position. A slight shock should be felt by hand gripping selector each time transaxle is shifted.
- Perform road test. Refer to "Road Test", AT-66.

GI

MA

EM

LC

EC

FE

AT

AX

SU

BR

ST

RS

BT

HA

SC

EL

IDX

OVERHAUL

Components

SEC. 311 • 313 • 327 • 381

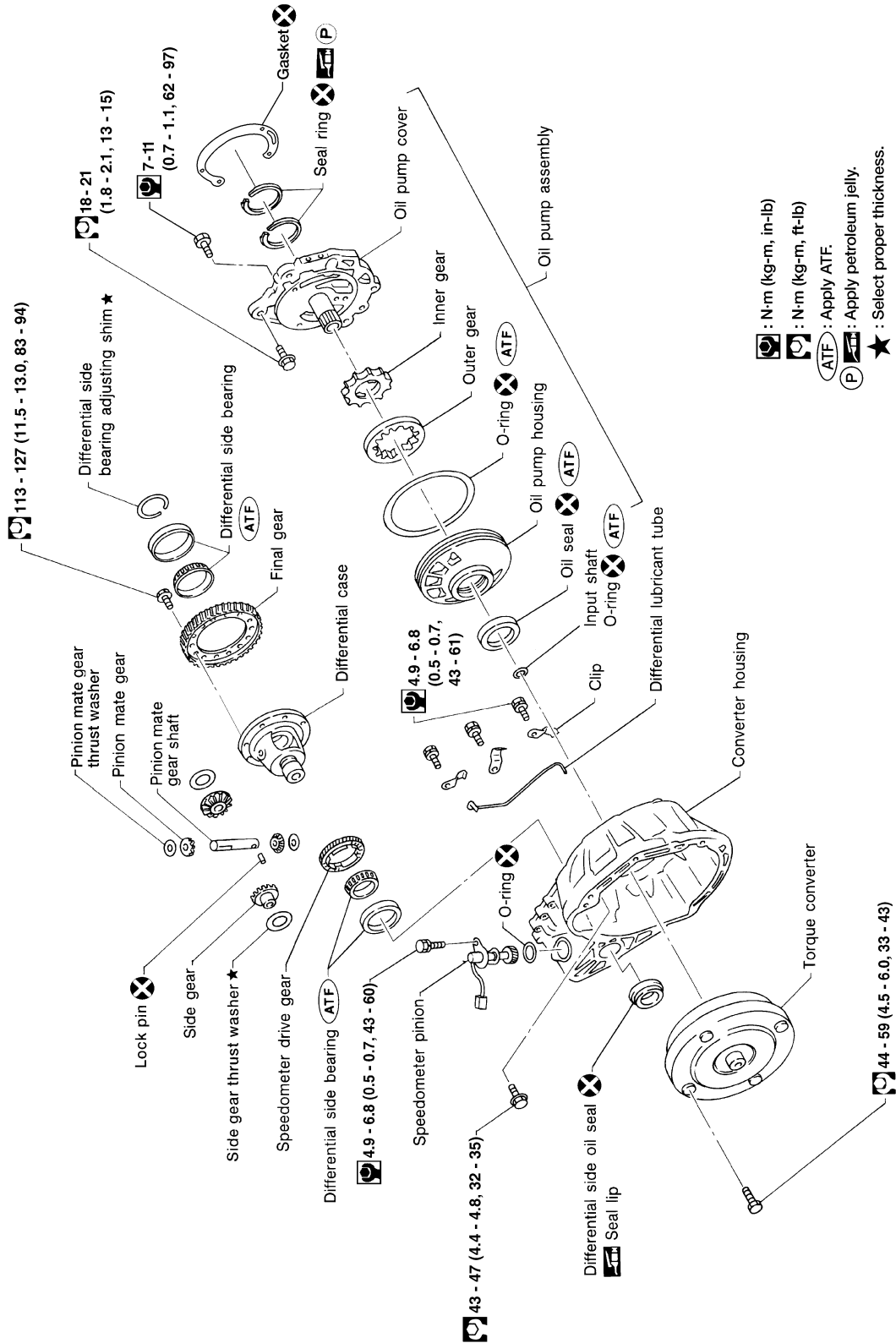

- : N-m (kg-m, in-lb)
- : N-m (kg-m, ft-lb)
- : Apply ATF.
- : Apply petroleum jelly.
- : Select proper thickness.

OVERHAUL

Oil Channel

Oil Channel

NDAT0120

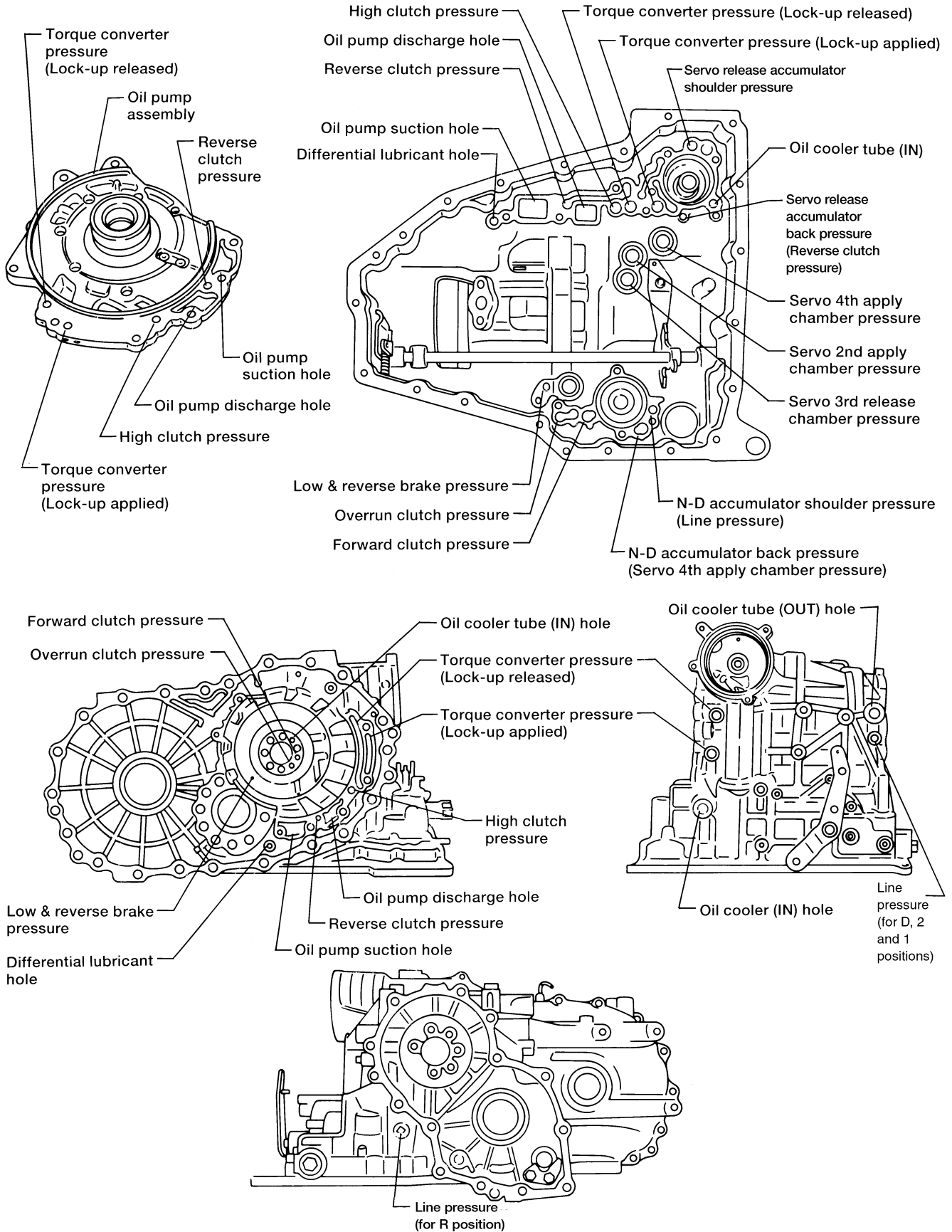

GI

MA

EM

LC

EC

FE

AT

AX

SU

BR

ST

RS

BT

HA

SC

EL

IDX

LAT386

OVERHAUL

Locations of Adjusting Shims, Needle Bearings, Thrust Washers and Snap Rings

Locations of Adjusting Shims, Needle Bearings, Thrust Washers and Snap Rings

NDAT0121

Outer diameter of thrust washers

Item number	Outer diameter mm (in)
J ★	76.0 (2.992)
K ★	80.0 (3.150)

★ : Select proper thickness

Outer and inner diameter of needle bearings

Item number	Outer diameter mm (in)	Inner diameter mm (in)
A	49.8 (1.961)	35.2 (1.386)
B	41.8 (1.646)	23.1 (0.909)
C	70.0 (2.756)	50.0 (1.969)
D	50.9 (2.004)	31.2 (1.228)
E	51.0 (2.008)	33.1 (1.303)
F	49.8 (1.961)	35.2 (1.386)
G	56.5 (2.224)	34.9 (1.374)
H	87.0 (3.425)	69.0 (2.717)
I	50.6 (1.992)	34.7 (1.366)

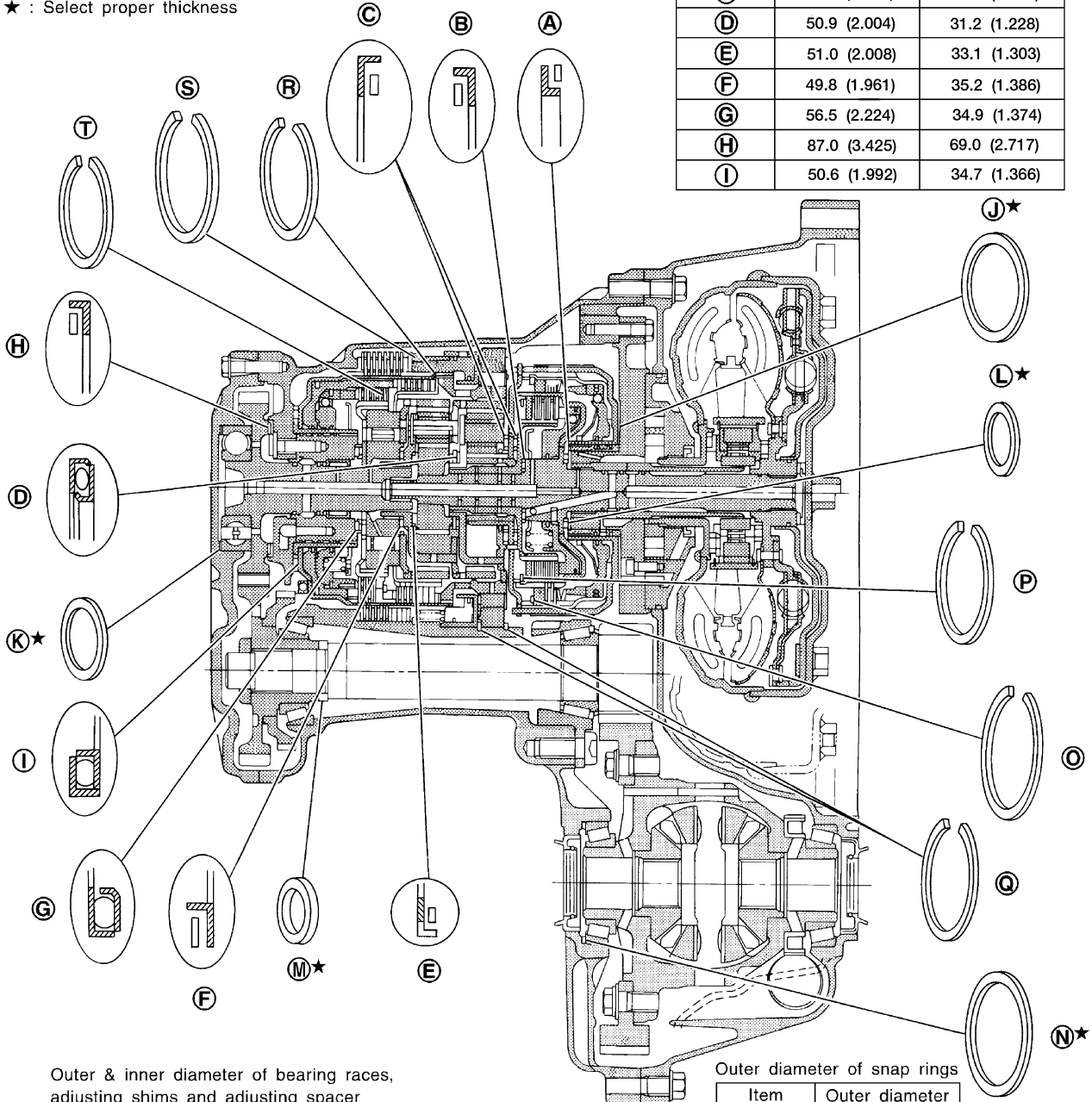

Outer & inner diameter of bearing races, adjusting shims and adjusting spacer

Item number	Outer diameter mm (in)	Inner diameter mm (in)
L ★	51.0 (2.008)	36.0 (1.417)
M ★	38.0 (1.496)	28.1 (1.106)
N ★	75.0 (2.953)	68.0 (2.677)
	98.0 (3.858)	91.0 (3.583)

★ : Select proper thickness

Outer diameter of snap rings

Item number	Outer diameter mm (in)
O	150 (5.91)
P	119.1 (4.689)
Q	182.8 (7.197)
R	144.8 (5.701)
S	173.8 (6.843)
T	133.9 (5.272)

WAT387

DISASSEMBLY

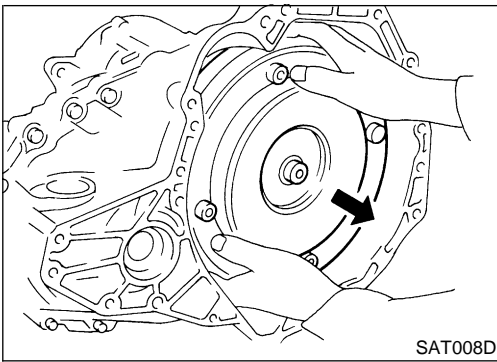

1. Drain ATF through drain plug.
2. Remove torque converter.

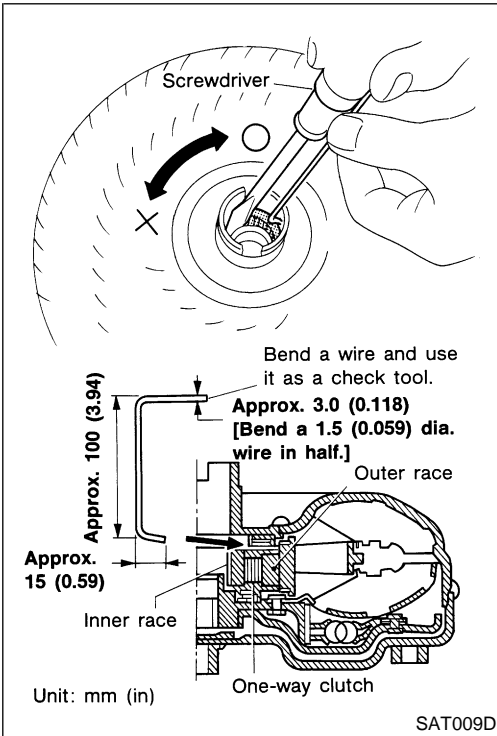

3. Check torque converter one-way clutch using check tool as shown at left.
 - a. Insert check tool into the groove of bearing support built into one-way clutch outer race.
 - b. When fixing bearing support with check tool, rotate one-way clutch spline using screwdriver.
 - c. Check that inner race rotates clockwise only. If not, replace torque converter assembly.

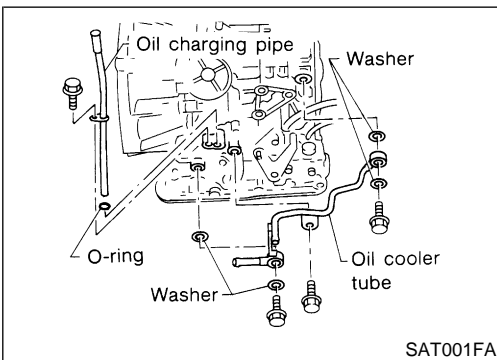

4. Remove oil charging pipe and oil cooler tube.

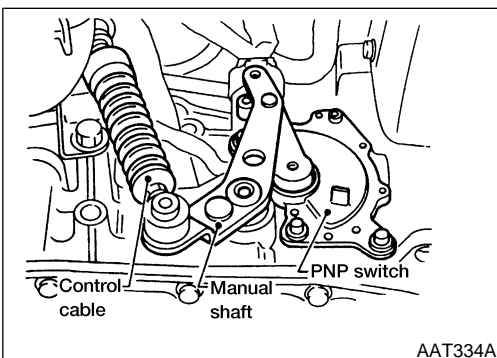

5. Set manual shaft to position P.
6. Remove park/neutral position (PNP) switch.

GI

MA

EM

LC

EC

FE

AT

AX

SU

BR

ST

RS

BT

HA

SC

EL

IDX

DISASSEMBLY

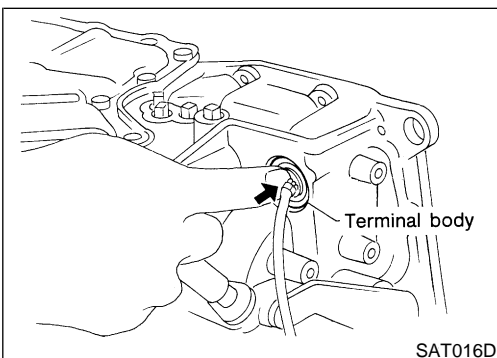
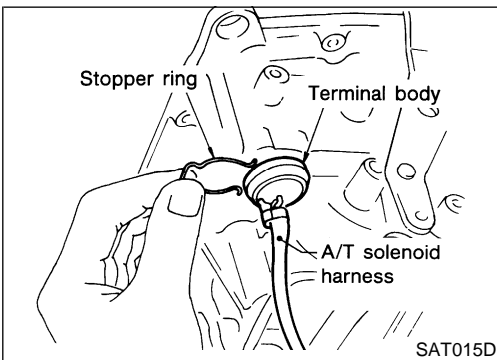
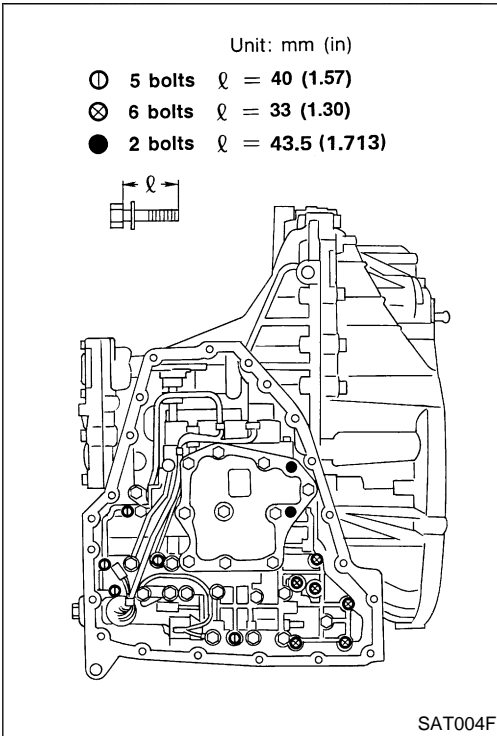
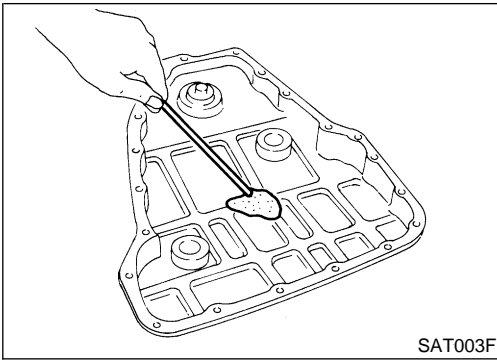

7. Remove oil pan and oil pan gasket.
 - **Always replace oil pan bolts as they are self-sealing bolts.**
8. Check foreign materials in oil pan to help determine causes of malfunction. If the fluid is very dark, smells burned, or contains foreign particles, the frictional material (clutches, band) may need replacement. A tacky film that will not wipe clean indicates varnish build up. Varnish can cause valves, servo, and clutches to stick and can inhibit pump pressure.
 - **If frictional material is detected, replace radiator after repair of A/T. Refer to LC-12, "Radiator".**
9. Remove control valve assembly according to the following procedures.
 - a. Remove control valve assembly mounting bolts I, X and ●.
 - b. Remove snap ring from terminal body.
 - c. Push terminal body into transmission case and draw out solenoid harness.

DISASSEMBLY

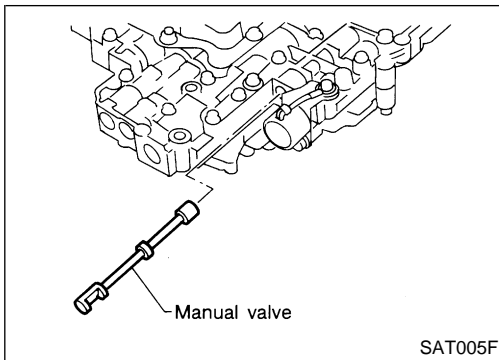

10. Remove manual valve from control valve assembly.

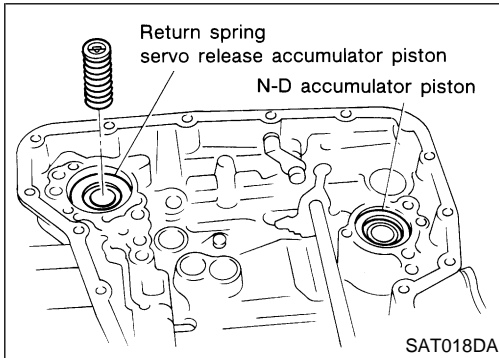

11. Remove return spring from servo release accumulator piston.

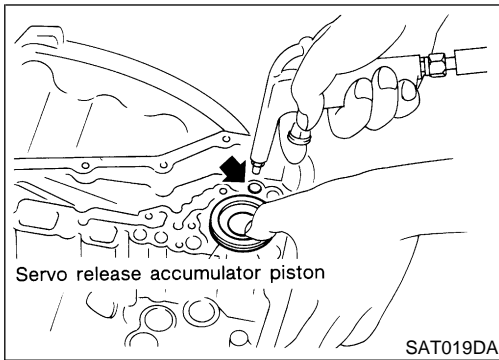

12. Remove servo release accumulator piston with compressed air.

13. Remove O-rings from servo release accumulator piston.

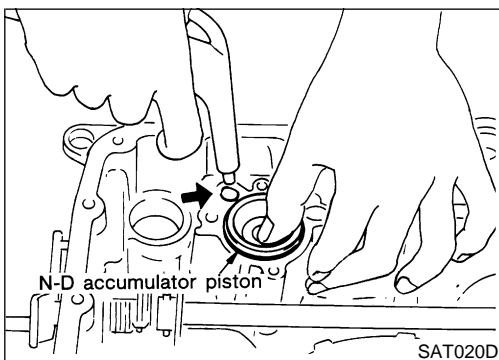

14. Remove N-D accumulator piston and return spring with compressed air.

15. Remove O-rings from N-D accumulator piston.

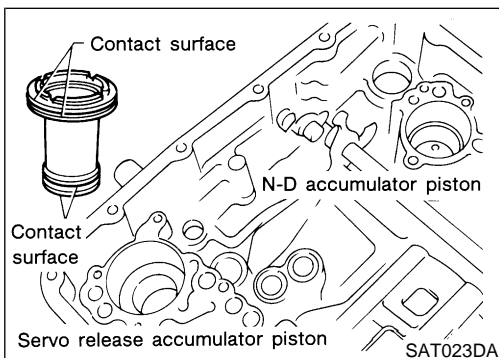

16. Check accumulator pistons and contact surface of transmission case for damage.

17. Check accumulator return springs for damage and free length.

GI

MA

EM

LC

EC

FE

AT

AX

SU

BR

ST

RS

BT

HA

SC

EL

IDX

DISASSEMBLY

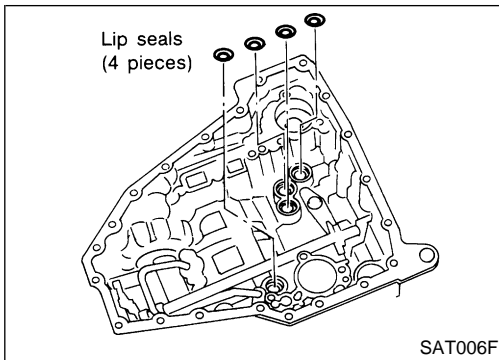

18. Remove lip seals.

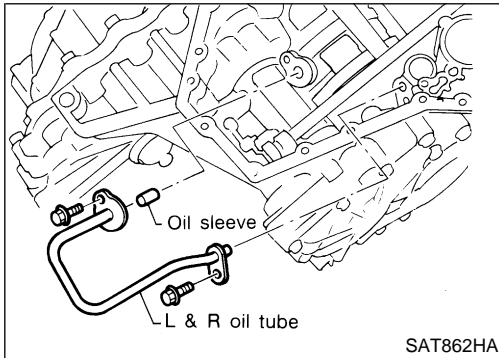

19. Remove L & R oil tube and oil sleeve.

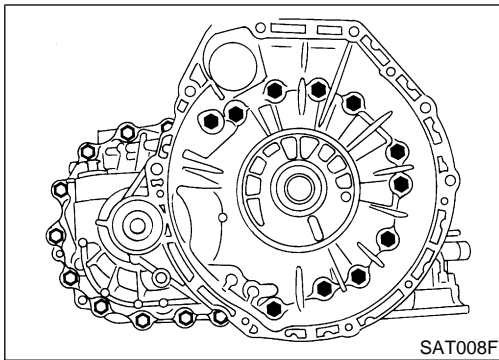

20. Remove converter housing according to the following procedures.

- a. Remove converter housing mounting bolts.
- b. Remove converter housing by tapping it lightly.

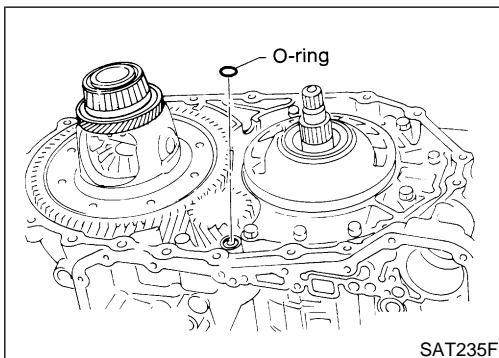

c. Remove O-ring from differential oil port.

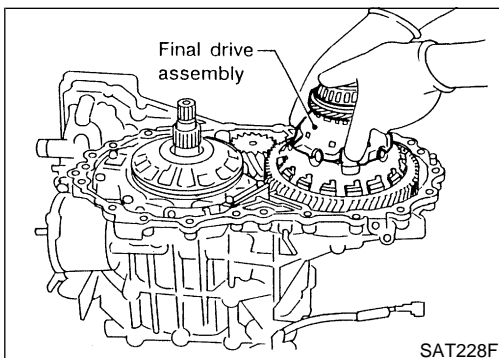

21. Remove final drive assembly from transmission case.

DISASSEMBLY

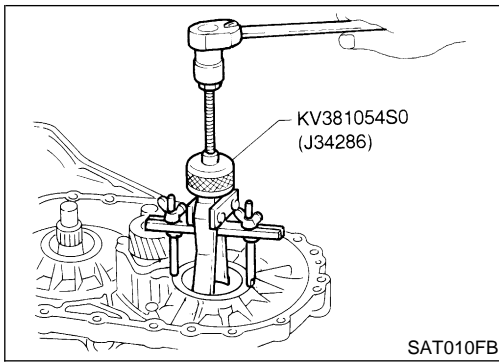

22. Remove differential side bearing outer race from transmission case.

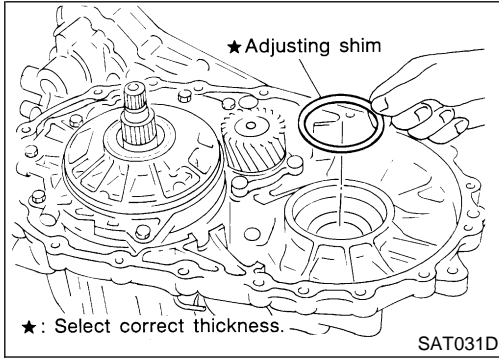

23. Remove differential side bearing adjusting shim from transmission case.

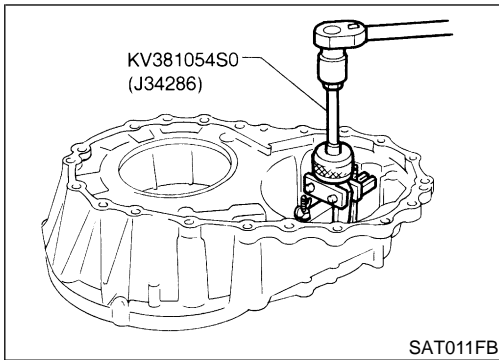

24. Remove differential side bearing outer race from converter housing.

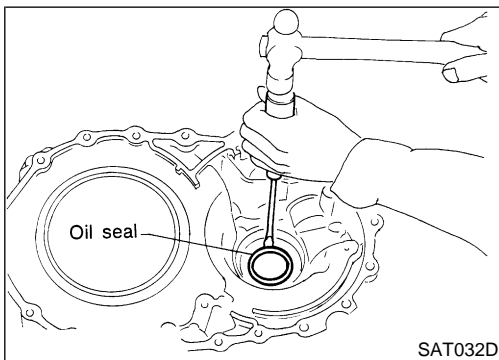

25. Remove oil seal with screwdriver from converter housing.
- **Be careful not to damage case.**

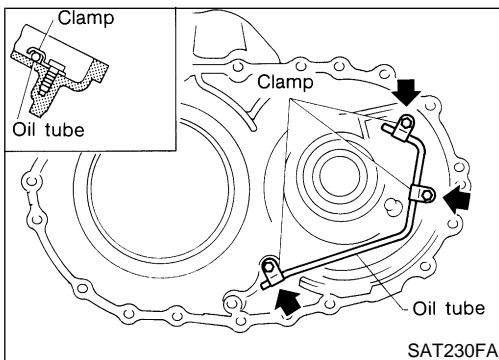

26. Remove oil tube from converter housing.

GI

MA

EM

LC

EC

FE

AT

AX

SU

BR

ST

RS

BT

HA

SC

EL

IDX

DISASSEMBLY

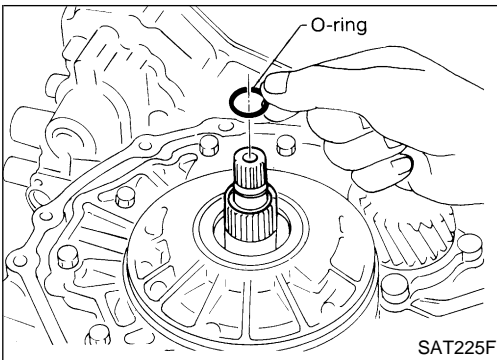

27. Remove oil pump according to the following procedures.
- Remove O-ring from input shaft.

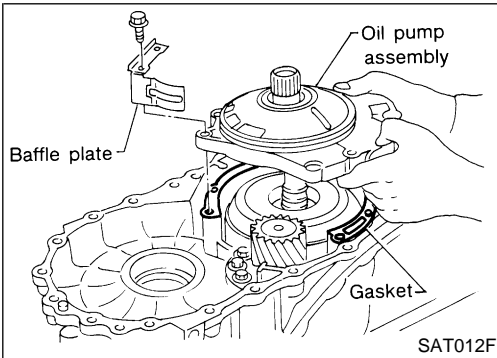

- Remove oil pump assembly, baffle plate and gasket from transmission case.

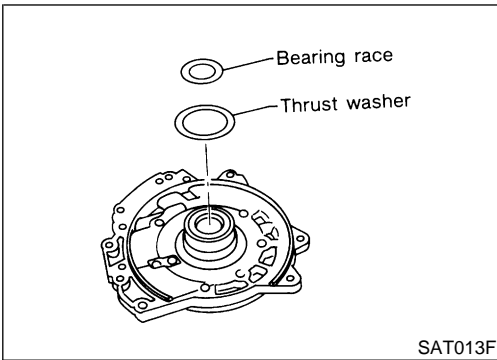

- Remove thrust washer and bearing race from oil pump assembly.

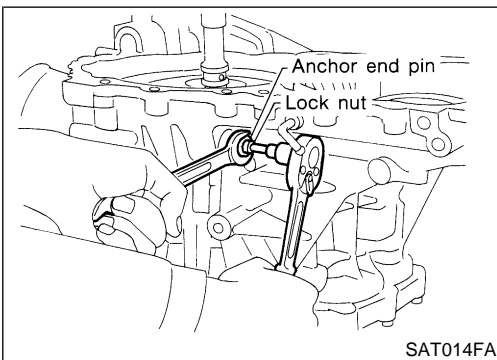

28. Remove brake band according to the following procedures.
- Loosen lock nut, then back off anchor end pin.
 - Do not reuse anchor end pin.**

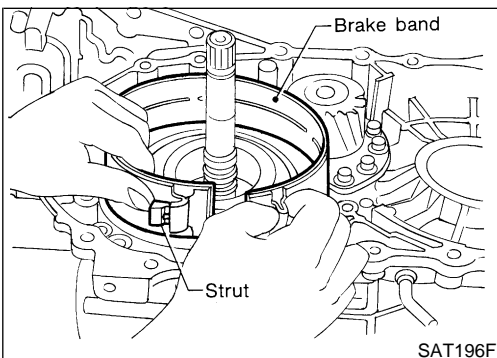

- Remove brake band and strut from transmission case.

DISASSEMBLY

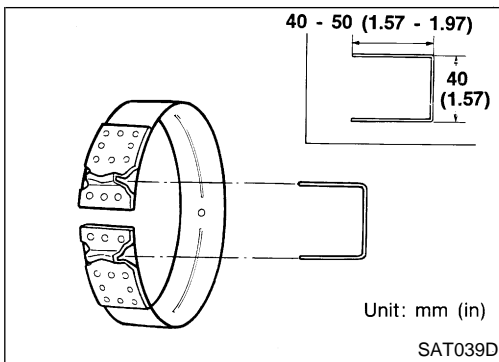

- To prevent brake linings from cracking or peeling, do not stretch the flexible band unnecessarily. When removing the brake band, always secure it with a clip as shown in the figure at left. Leave the clip in position after removing the brake band.

GI

MA

EM

LC

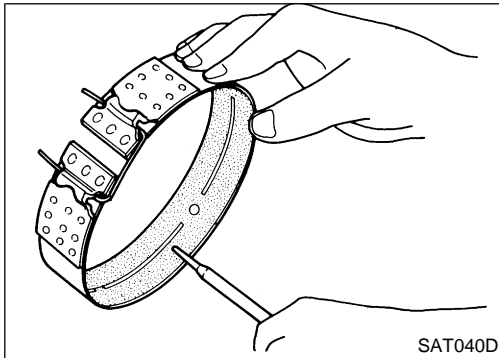

- Check brake band facing for damage, cracks, wear or burns.

EC

FE

AT

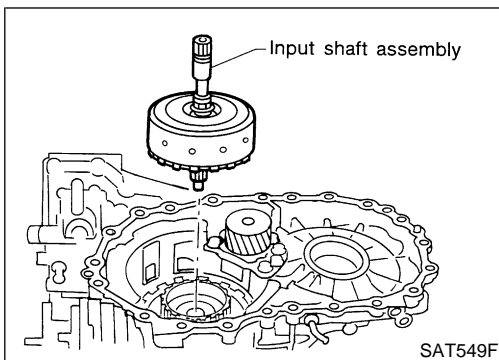

- Remove input shaft assembly (high clutch) and reverse clutch according to the following procedures.

- Remove input shaft assembly (high clutch) with reverse clutch.

SU

BR

ST

RS

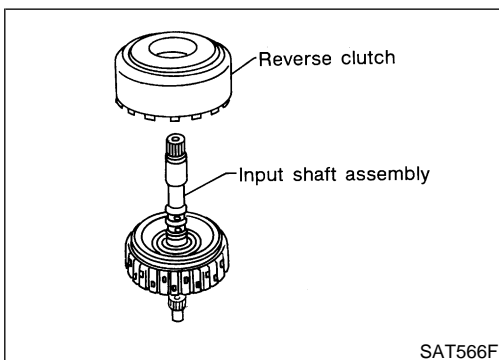

- Remove input shaft assembly (high clutch) from reverse clutch.

BT

HA

SC

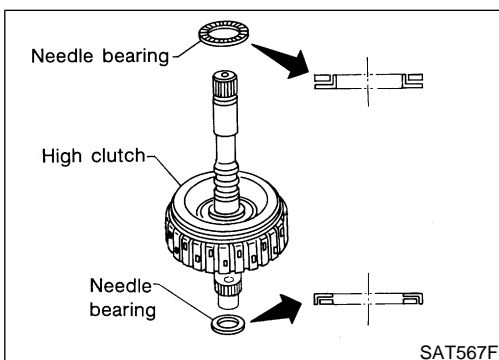

- Remove needle bearings from high clutch drum and check for damage or wear.

IDX

DISASSEMBLY

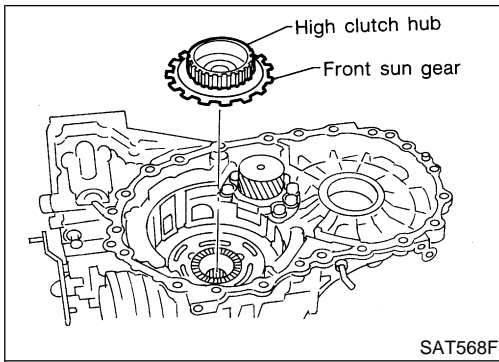

d. Remove high clutch hub and front sun gear from transmission case.

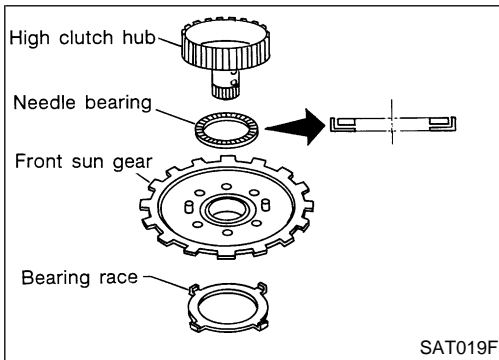

e. Remove front sun gear and needle bearing from high clutch hub and check for damage or wear.

f. Remove bearing race from front sun gear and check for damage or wear.

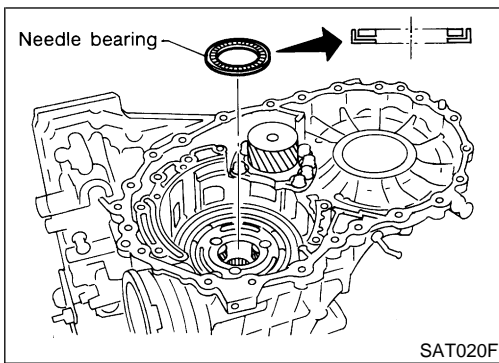

30. Remove needle bearing from transmission case and check for damage or wear.

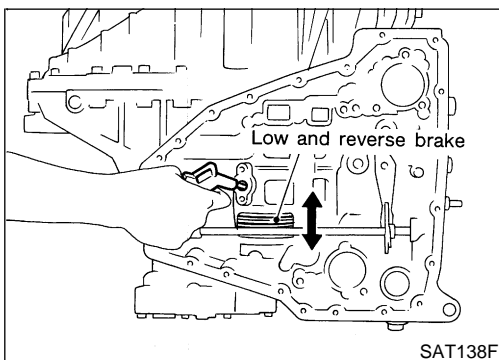

31. Apply compressed air and check to see that low and reverse brake operates.

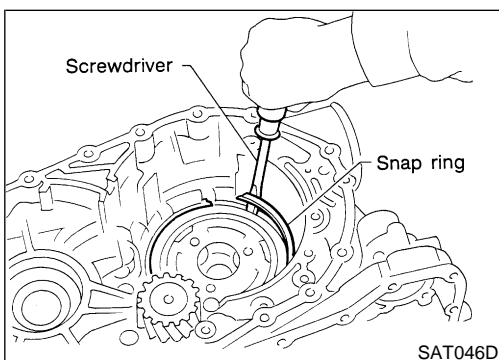

32. Remove low one-way clutch and front planetary carrier assembly according to the following procedures.

a. Remove snap ring with flat-bladed screwdriver.

DISASSEMBLY

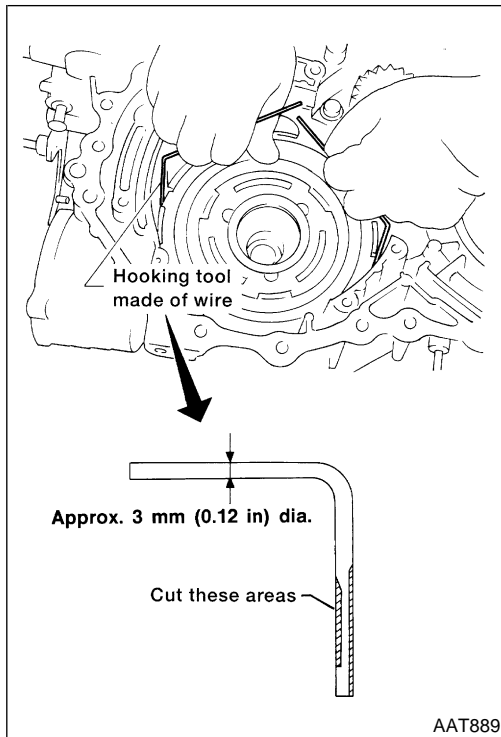

- b. Remove low one-way clutch with a hook made of wire.

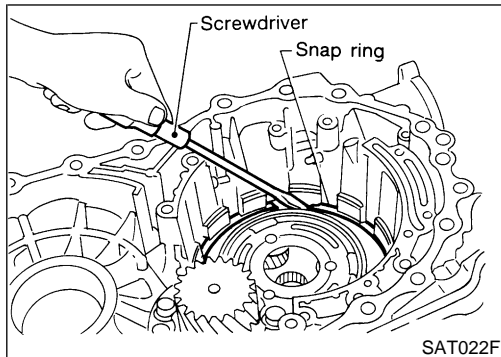

- c. Remove snap ring with flat-bladed screwdriver.

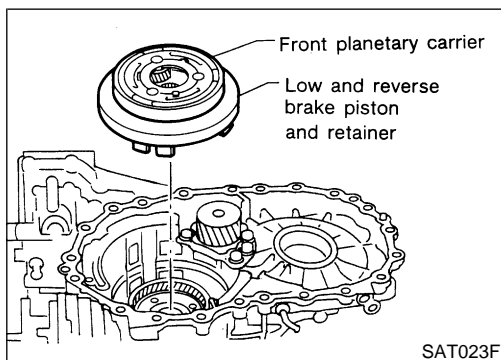

- d. Remove front planetary carrier with low and reverse brake piston and retainer.

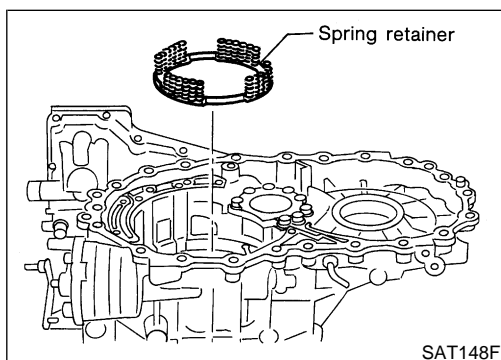

- e. Remove low and reverse brake spring retainer.
- Do not remove return springs from spring retainer.

GI

MA

EM

LC

EC

FE

AT

AX

SU

BR

ST

RS

BT

HA

SC

EL

IDX

DISASSEMBLY

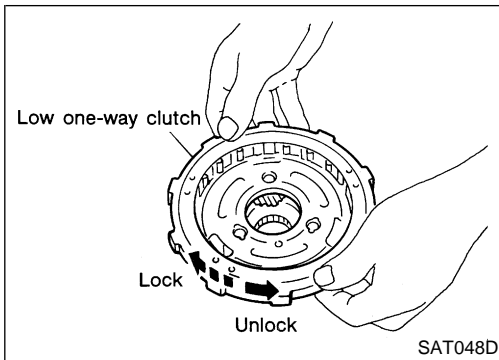

- f. Check that low one-way clutch rotates in the direction of the arrow and locks in the opposite direction.

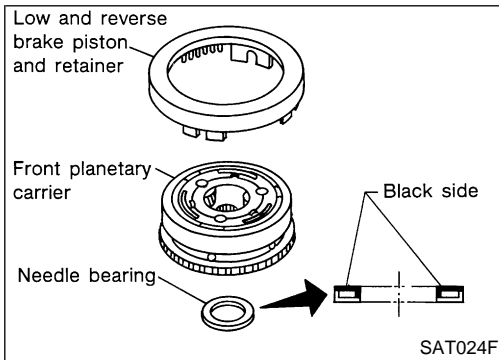

- g. Remove needle bearing, low and reverse brake piston and retainer from front planetary carrier.

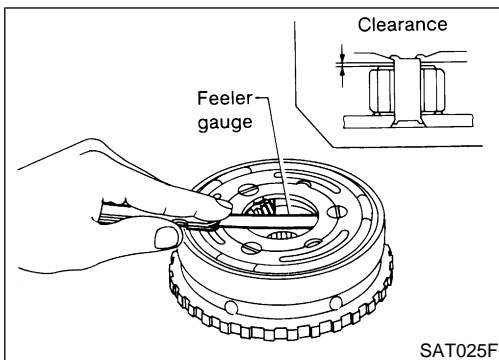

- h. Check front planetary carrier, low one-way clutch and needle bearing for damage or wear.

- i. Check clearance between planetary gears and planetary carrier with feeler gauge.

Standard clearance:

0.20 - 0.70 mm (0.0079 - 0.0276 in)

Allowable limit:

0.80 mm (0.0315 in)

Replace front planetary carrier if the clearance exceeds allowable limit.

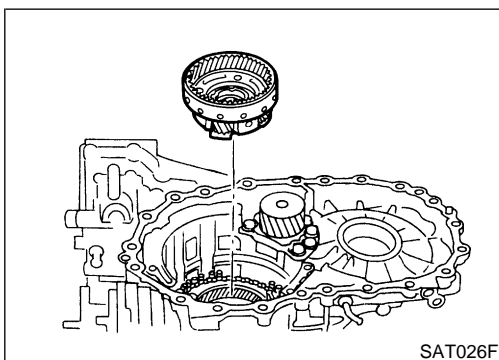

33. Remove rear planetary carrier assembly and rear sun gear according to the following procedures.

- a. Remove rear planetary carrier assembly from transmission case.

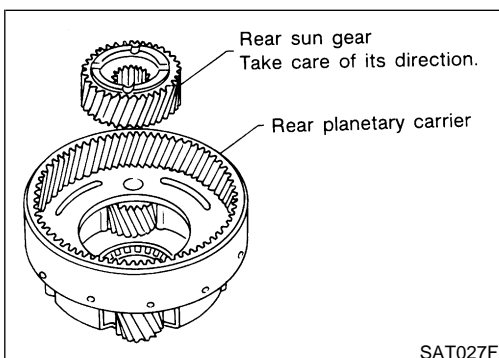

- b. Remove rear sun gear from rear planetary carrier.

DISASSEMBLY

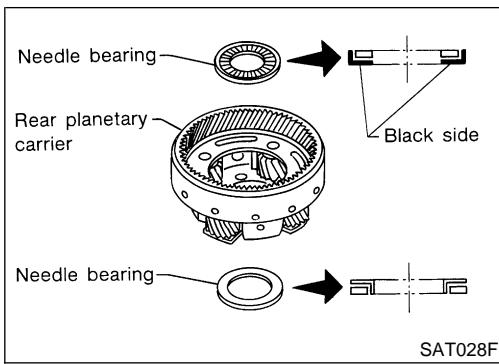

c. Remove needle bearings from rear planetary carrier assembly.

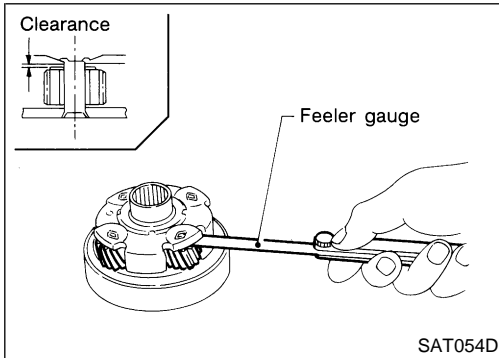

d. Check rear planetary carrier, rear sun gear and needle bearings for damage or wear.

e. Check clearance between pinion washer and rear planetary carrier with feeler gauge.

Standard clearance:

0.20 - 0.70 mm (0.0079 - 0.0276 in)

Allowable limit:

0.80 mm (0.0315 in)

Replace rear planetary carrier if the clearance exceeds allowable limit.

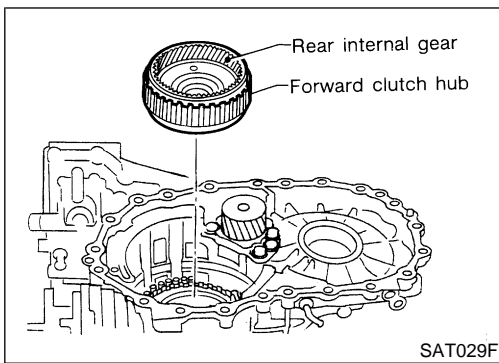

34. Remove rear internal gear and forward clutch hub from transmission case.

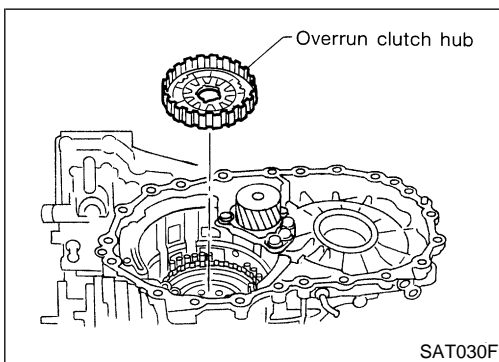

35. Remove overrun clutch hub from transmission case.

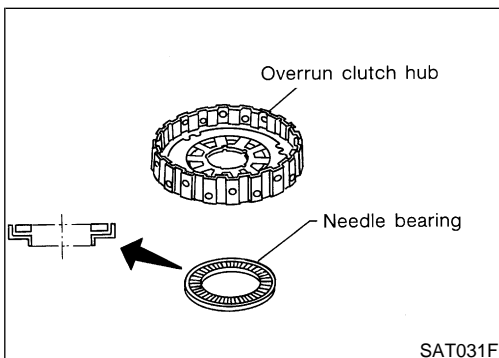

36. Remove needle bearing from overrun clutch hub and check for damage or wear.

GI

MA

EM

LC

EC

FE

AT

AX

SU

BR

ST

RS

BT

HA

SC

EL

IDX

DISASSEMBLY

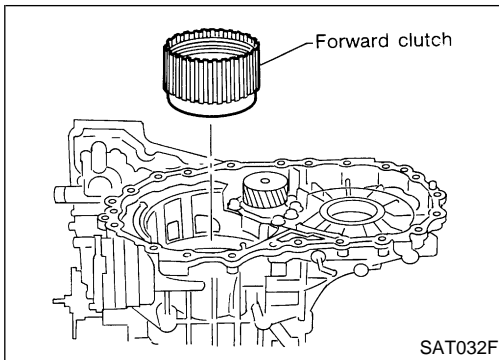

37. Remove forward clutch assembly from transmission case.

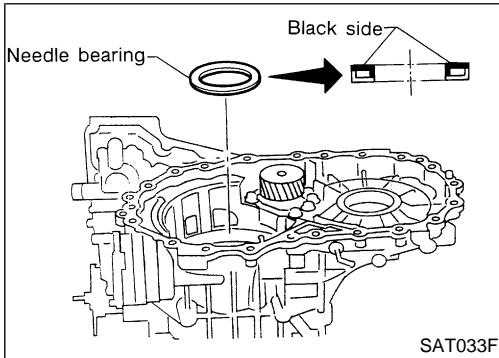

38. Remove needle bearing from transmission case.

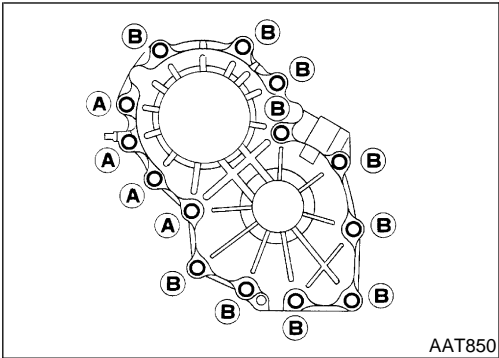

39. Remove output shaft assembly according to the following procedures.

a. Remove side cover bolts.

- Do not mix bolts A and B.
- Always replace bolts A as they are self-sealing bolts.

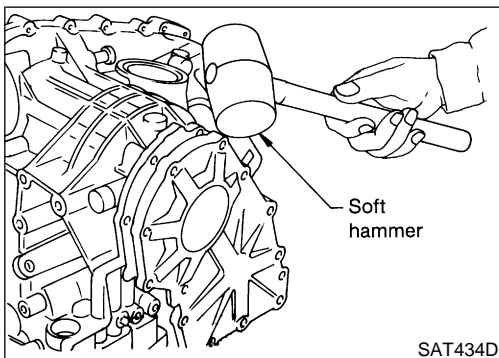

b. Remove side cover by lightly tapping it with a soft hammer.

- Be careful not to drop output shaft assembly. It might come out when removing side cover.

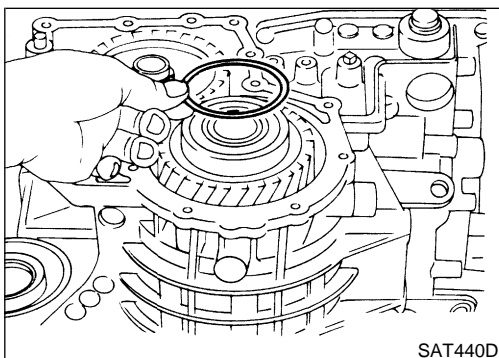

c. Remove adjusting shim.

DISASSEMBLY

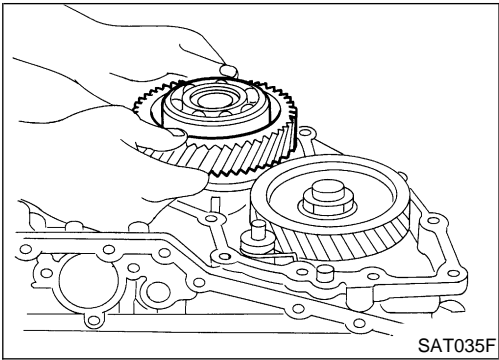

d. Remove output shaft assembly.

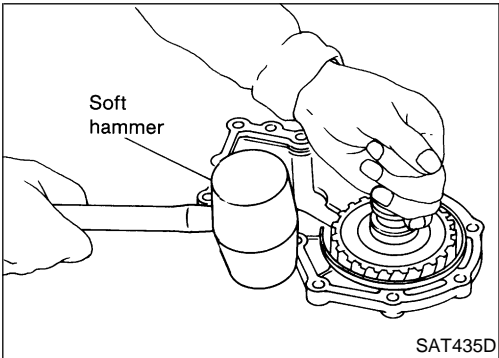

- If output shaft assembly came off with side cover, tap cover with a soft hammer to separate.

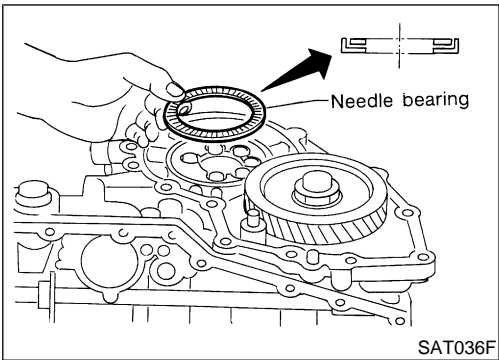

e. Remove needle bearing.

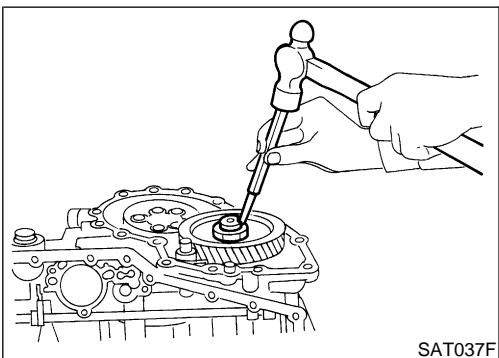

40. Disassemble reduction pinion gear according to the following procedures.

- a. Set manual shaft to position P to fix idler gear.
- b. Unlock idler gear lock nut using a pin punch.

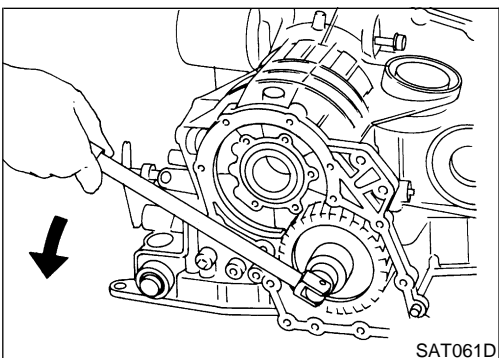

c. Remove idler gear lock nut.

- Do not reuse idler gear lock nut.

GI

MA

EM

LC

EC

FE

AT

AX

SU

BR

ST

RS

BT

HA

SC

EL

IDX

DISASSEMBLY

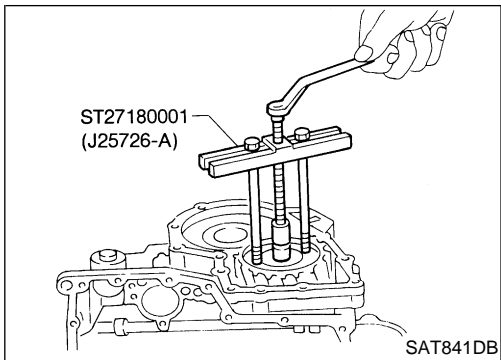

d. Remove idler gear with puller.

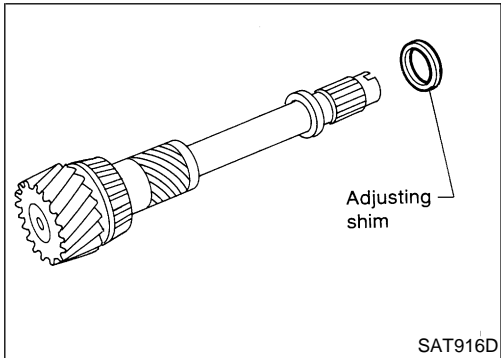

e. Remove reduction pinion gear.

f. Remove adjusting shim from reduction pinion gear.

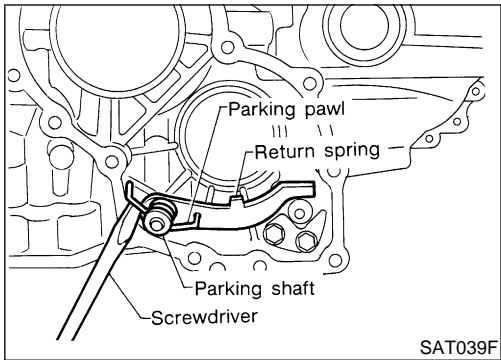

41. Remove return spring from parking shaft with screwdriver.

42. Draw out parking shaft and remove parking pawl from transmission case.

43. Check parking pawl and shaft for damage or wear.

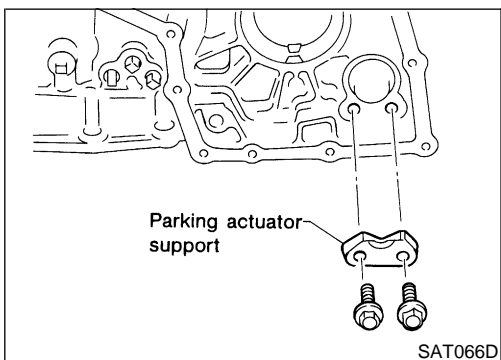

44. Remove parking actuator support from transmission case.

45. Check parking actuator support for damage or wear.

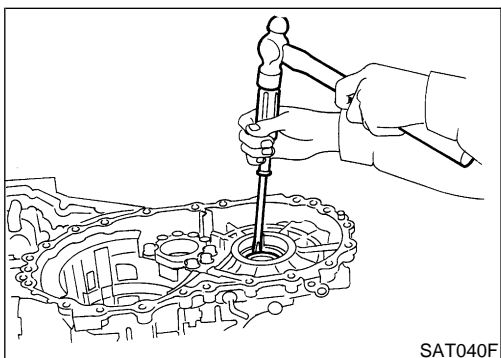

46. Remove side oil seal with screwdriver from transmission case.

Manual Shaft COMPONENTS

NDAT0123

GI

MA

EM

LC

EC

FE

AT

AX

SU

BR

ST

RS

BT

HA

SC

EL

IDX

SEC. 319

 6.4 - 7.5 N·m
(0.65 - 0.76 kg-m,
56.4 - 66.0 in-lb)

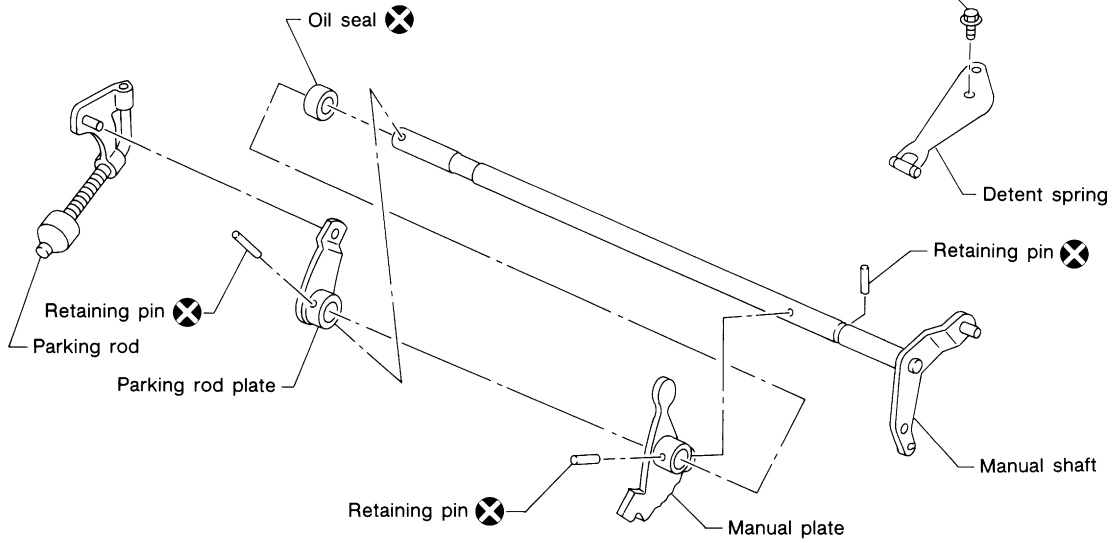

SAT451HA

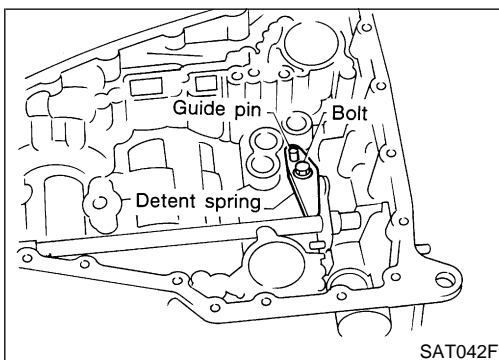

SAT042F

REMOVAL

NDAT0124

1. Remove detent spring from transmission case.

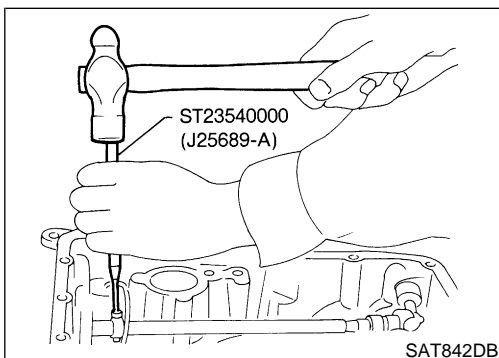

SAT842DB

2. Drive out manual plate retaining pin.

REPAIR FOR COMPONENT PARTS

Manual Shaft (Cont'd)

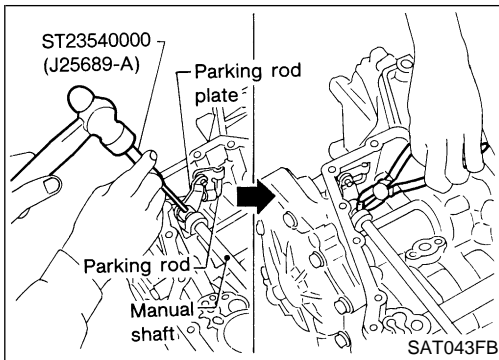

3. Drive and pull out parking rod plate retaining pin.
4. Remove parking rod plate from manual shaft.
5. Draw out parking rod from transmission case.

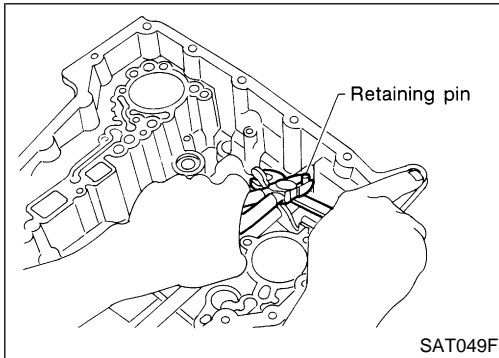

6. Pull out manual shaft retaining pin.
7. Remove manual shaft and manual plate from transmission case.

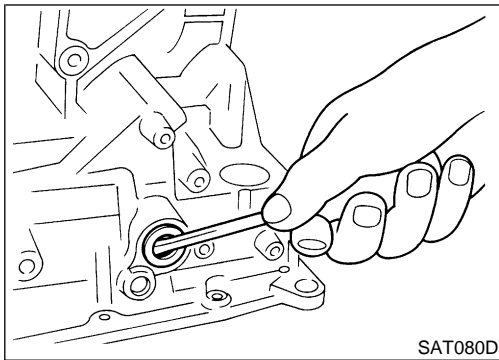

8. Remove manual shaft oil seal.

INSPECTION

- Check component parts for wear or damage. Replace if necessary. NDAT0125

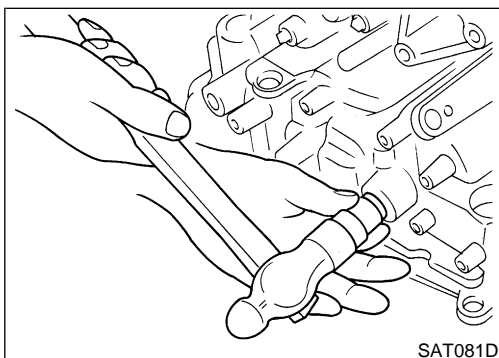

INSTALLATION

1. Install manual shaft oil seal.
- Apply ATF to outer surface of oil seal. NDAT0126

REPAIR FOR COMPONENT PARTS

Manual Shaft (Cont'd)

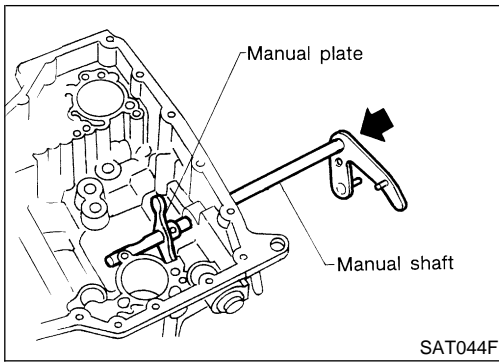

2. Install manual shaft and manual plate.

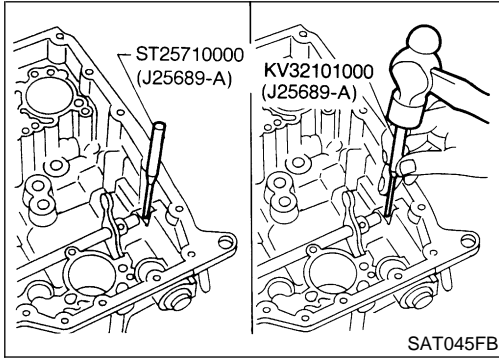

3. Align groove of manual shaft and hole of transmission case.
4. Install manual shaft retaining pin up to bottom of hole.

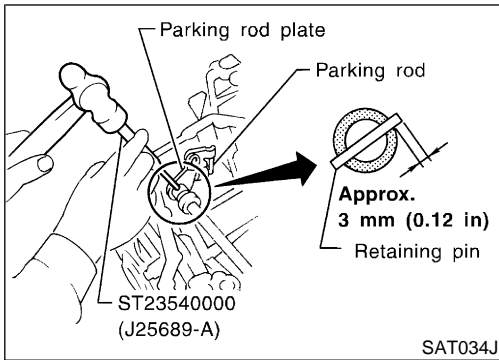

5. Install parking rod to parking rod plate.
6. Set parking rod assembly onto manual shaft and drive retaining pin.
● Both ends of pin should protrude.

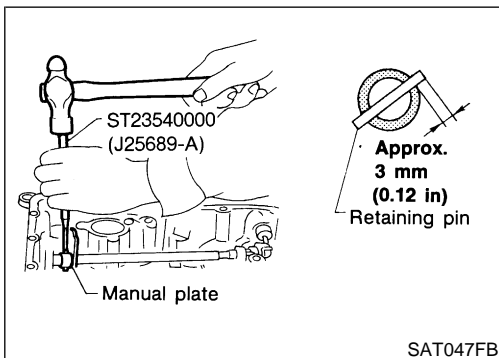

7. Drive manual plate retaining pin.
● Both ends of pin should protrude.

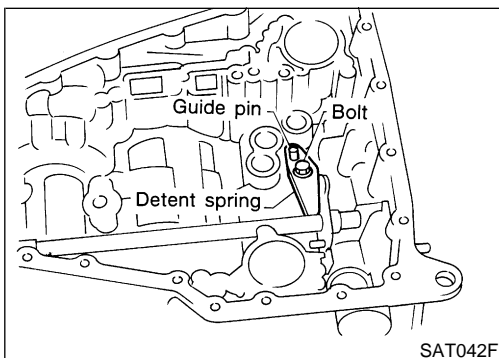

8. Install detent spring.

GI

MA

EM

LC

EC

FE

AT

AX

SU

BR

ST

RS

BT

HA

SC

EL

IDX

REPAIR FOR COMPONENT PARTS

Oil Pump

Oil Pump COMPONENTS

NDAT0127

SEC. 313

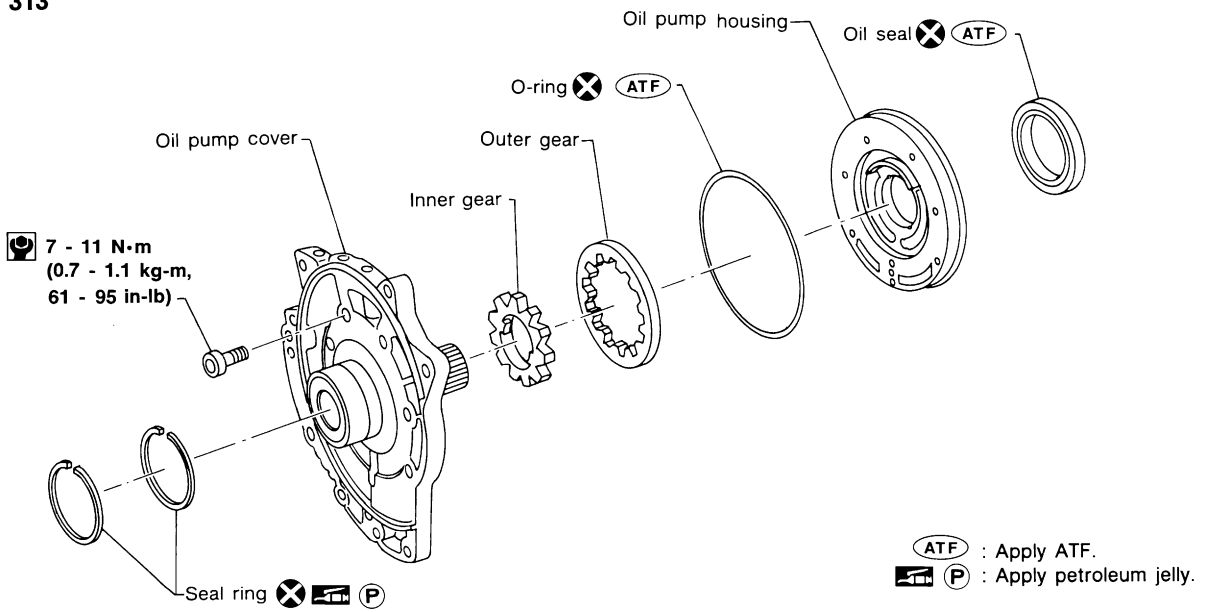

SAT050FC

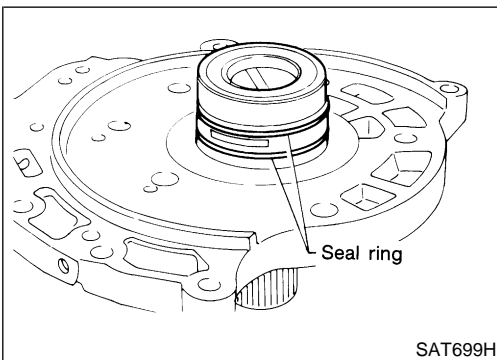

DISASSEMBLY

1. Remove seal rings.

NDAT0128

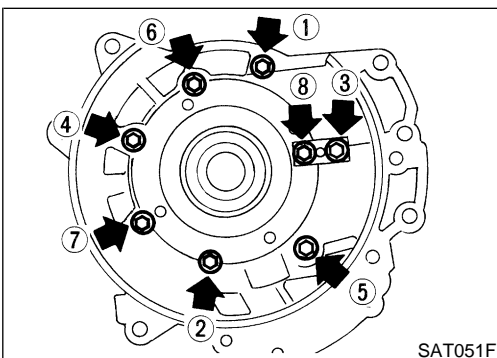

2. Loosen bolts in a crisscross pattern and remove oil pump cover.

REPAIR FOR COMPONENT PARTS

Oil Pump (Cont'd)

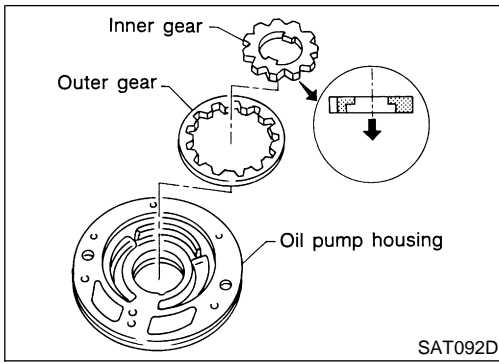

3. Remove inner and outer gear from oil pump housing.

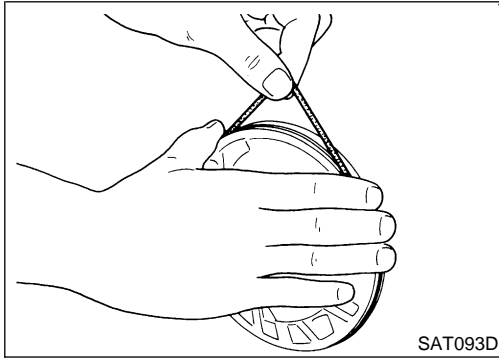

4. Remove O-ring from oil pump housing.

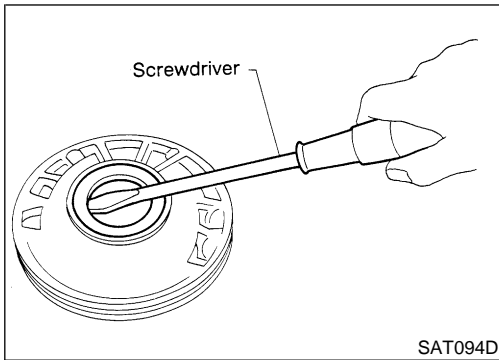

5. Remove oil pump housing oil seal.

INSPECTION

Oil Pump Housing, Oil Pump Cover, Inner Gear and Outer Gear

- Check for wear or damage.

GI

MA

EM

LC

EC

FE

AT

AX

SU

BR

ST

RS

BT

HA

SC

EL

IDX

REPAIR FOR COMPONENT PARTS

Oil Pump (Cont'd)

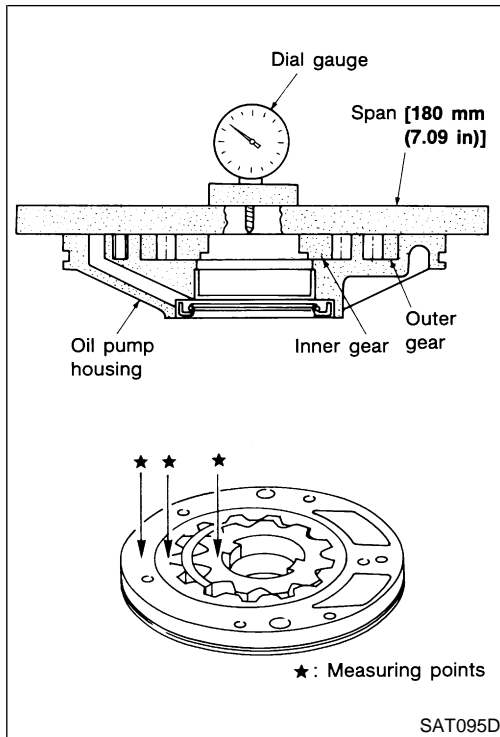

Side Clearances

NDAT0129S02

- Measure side clearance of inner and outer gears in at least four places around each outside edge. Maximum measured values should be within specified positions.

Standard clearance:

0.030 - 0.050 mm (0.0012 - 0.0020 in)

- If clearance is less than standard, select inner and outer gear as a set so that clearance is within specifications.

Inner and outer gear:

Refer to "OIL PUMP", AT-375.

- If clearance is more than standard, replace whole oil pump assembly except oil pump cover.

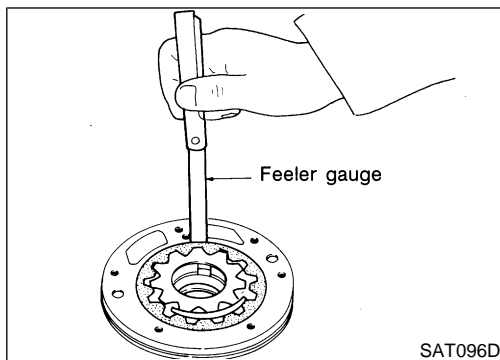

- Measure clearance between outer gear and oil pump housing.

Standard clearance:

0.111 - 0.181 mm (0.0044 - 0.0071 in)

Allowable limit:

0.181 mm (0.0071 in)

- If not within allowable limit, replace whole oil pump assembly except oil pump cover.

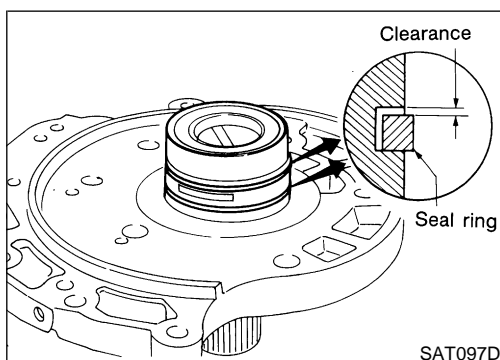

Seal Ring Clearance

NDAT0129S03

- Measure clearance between seal ring and ring groove.

Standard clearance:

0.1 - 0.25 mm (0.0039 - 0.0098 in)

Allowable limit:

0.25 mm (0.0098 in)

- If not within allowable limit, replace oil pump cover assembly.

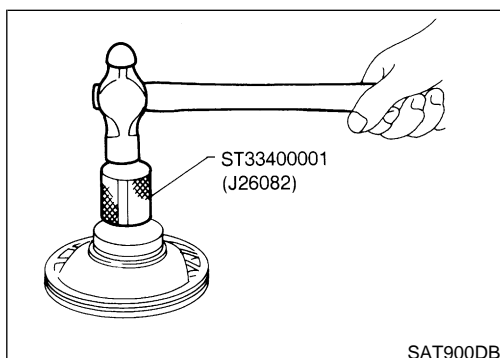

ASSEMBLY

NDAT0130

1. Install oil seal on oil pump housing.

REPAIR FOR COMPONENT PARTS

Oil Pump (Cont'd)

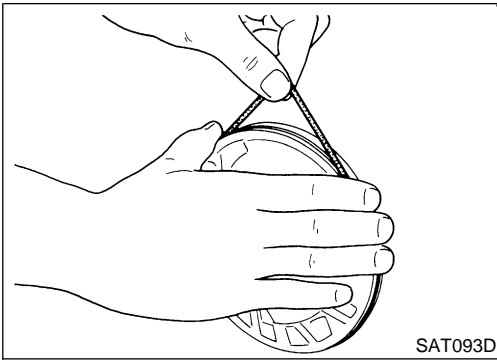

2. Install O-ring on oil pump housing.
 - **Apply ATF to O-ring.**

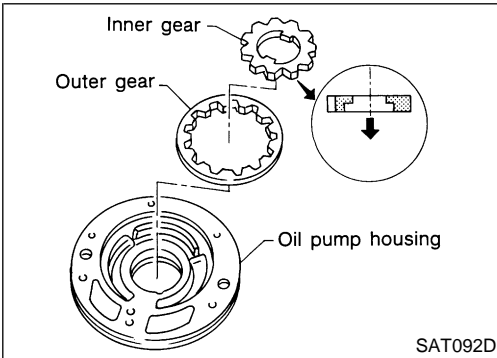

3. Install inner and outer gears on oil pump housing.
 - **Be careful of direction of inner gear.**

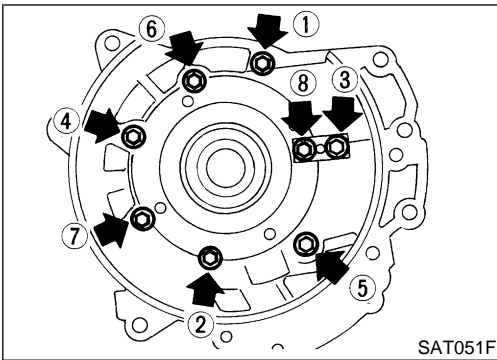

4. Install oil pump cover on oil pump housing.
 - a. Wrap masking tape around splines of oil pump cover assembly to protect seal. Position oil pump cover assembly on oil pump housing assembly, then remove masking tape.
 - b. Tighten bolts in a crisscross pattern.
🔩 : 7 - 11 N·m (0.7 - 1.1 kg·m, 61 - 95 in·lb)

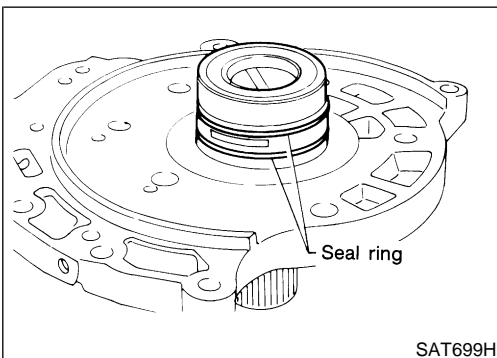

5. Install new seal rings carefully after packing ring groove with petroleum jelly.
 - **Do not spread gap of seal ring excessively while installing. The ring may be deformed.**

GI

MA

EM

LC

EC

FE

AT

AX

SU

BR

ST

RS

BT

HA

SC

EL

IDX

REPAIR FOR COMPONENT PARTS

Control Valve Assembly

Control Valve Assembly COMPONENTS

=NDAT0131

SEC. 317

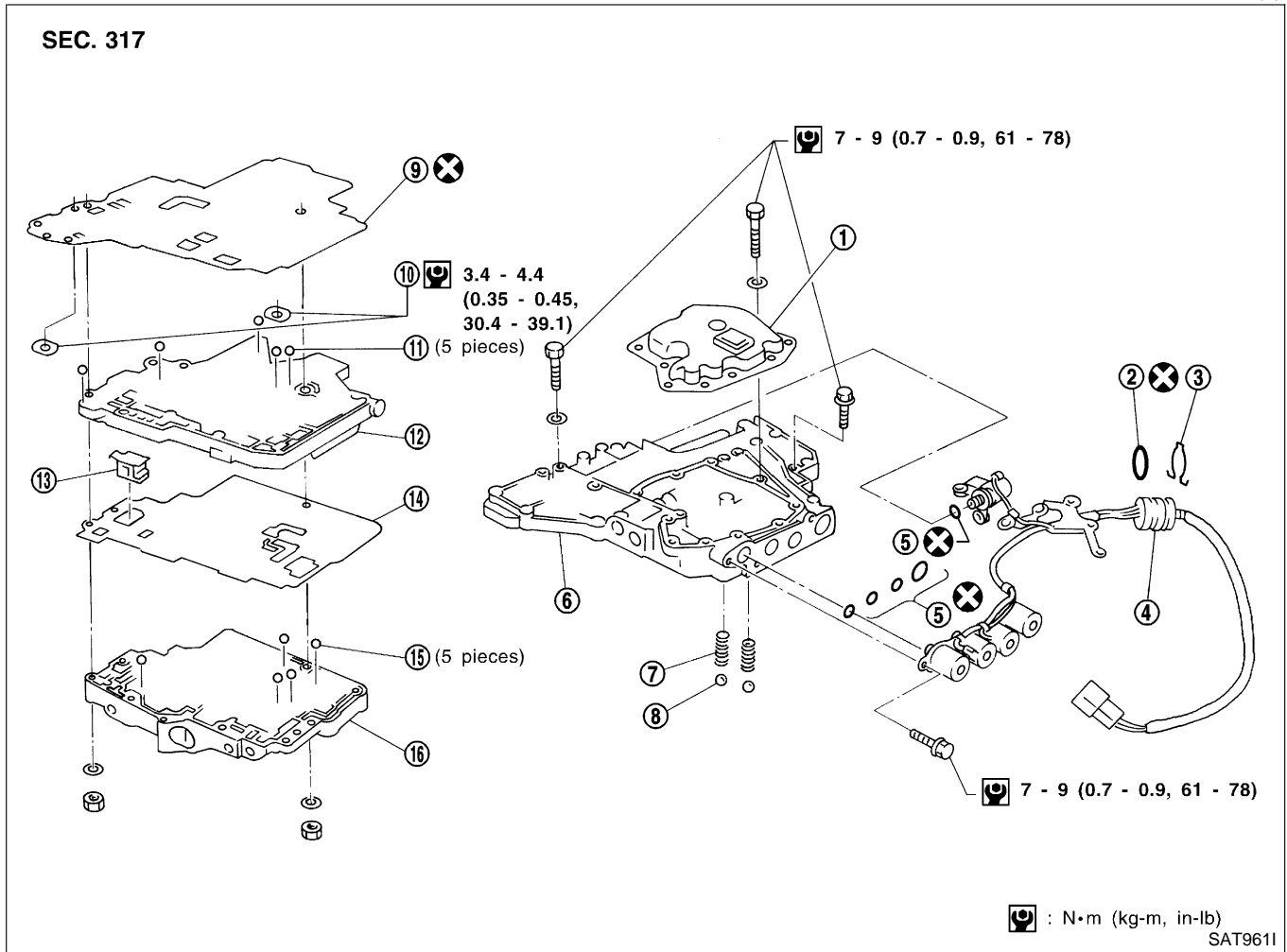

- | | | |
|-----------------------------|-----------------------------------|------------------------------|
| 1. Oil strainer | 7. Oil cooler relief valve spring | 12. Control valve inter body |
| 2. O-ring | 8. Check ball | 13. Pilot filter |
| 3. Snap ring | 9. Separating plate | 14. Separating plate |
| 4. Terminal body | 10. Support plate | 15. Steel ball |
| 5. O-rings | 11. Steel ball | 16. Control valve upper body |
| 6. Control valve lower body | | |

DISASSEMBLY

NDAT0132

Disassemble upper, inter and lower bodies.

Bolt length, number and location:

Bolt symbol	a	b	c	d	e	f	g
Bolt length "ℓ" mm (in)	13.5 (0.531)	58.0 (2.283)	40.0 (1.575)	66.0 (2.598)	33.0 (1.299)	78.0 (3.071)	18.0 (0.709)
							
Number of bolts	6	3	6	11	2	2	1

f: Reamer bolt and nut.

REPAIR FOR COMPONENT PARTS

Control Valve Assembly (Cont'd)

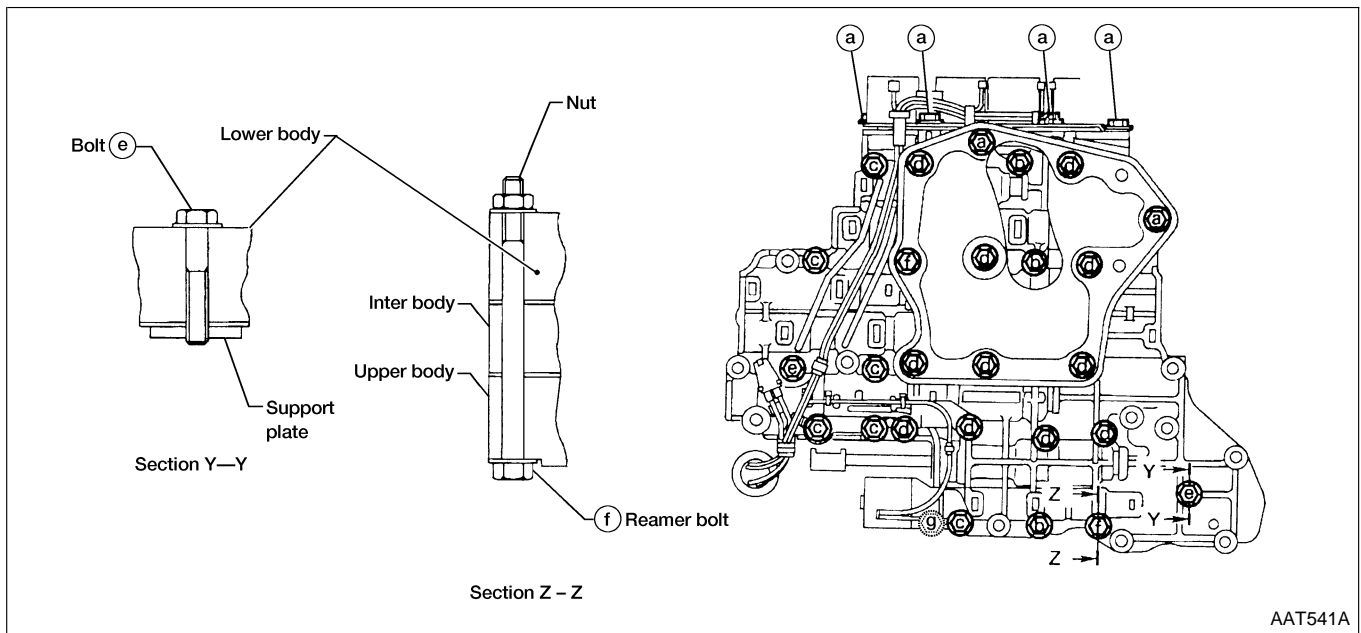

GI
MA
EM
LC
EC
FE

AT

AX

SU

BR

ST

RS

BT

HA

SC

EL

IDX

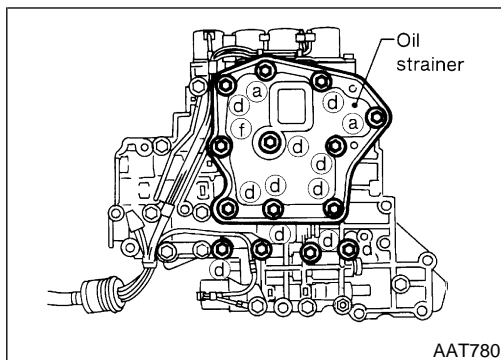

1. Remove bolts **a**, **d** and nut **f** and remove oil strainer from control valve assembly.

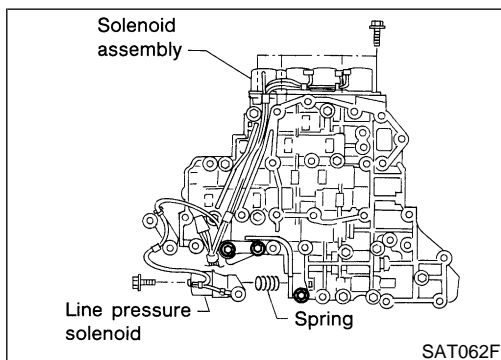

2. Remove solenoid valve assembly and line pressure solenoid valve from control valve assembly.

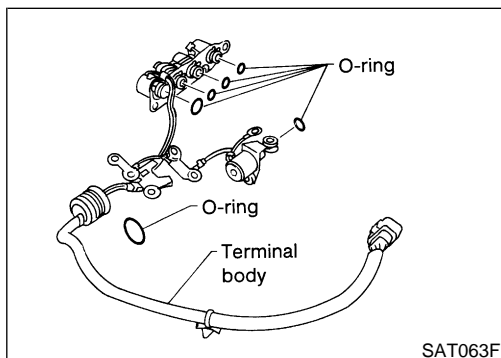

3. Remove O-rings from solenoid valves and terminal body.

REPAIR FOR COMPONENT PARTS

Control Valve Assembly (Cont'd)

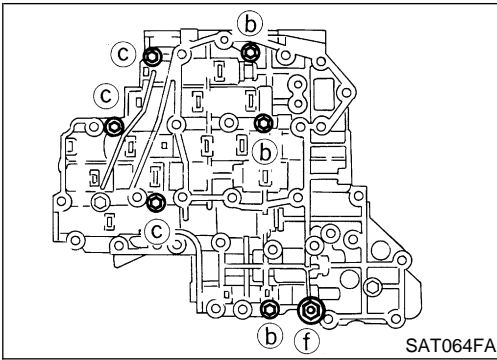

4. Place upper body facedown, and remove bolts **b**, **c** and nut **f**.

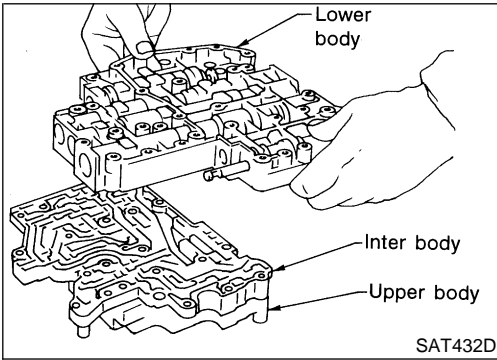

5. Remove inter body from lower body.

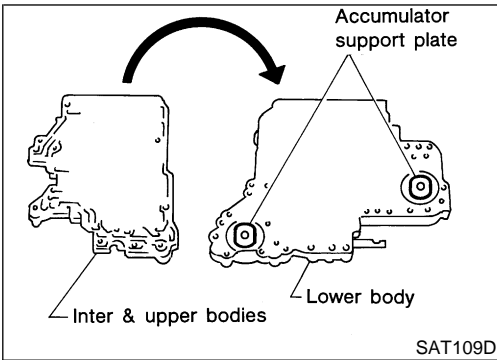

6. Turn over lower body, and remove accumulator support plate.

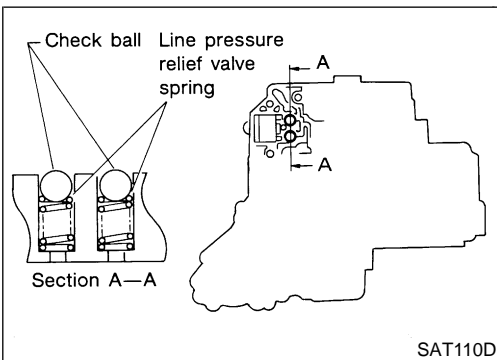

7. Remove bolts **e**, separating plate and separating gasket from lower body.

8. Remove steel balls and relief valve springs from lower body.

● **Be careful not to lose steel balls and relief valve springs.**

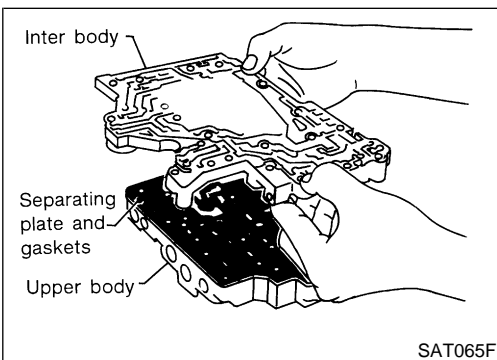

9. Remove inter body from upper body.

REPAIR FOR COMPONENT PARTS

Control Valve Assembly (Cont'd)

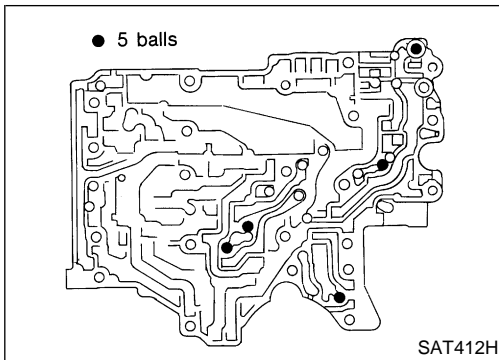

10. Check to see that steel balls are properly positioned in inter body and then remove them.

- Be careful not to lose steel balls.

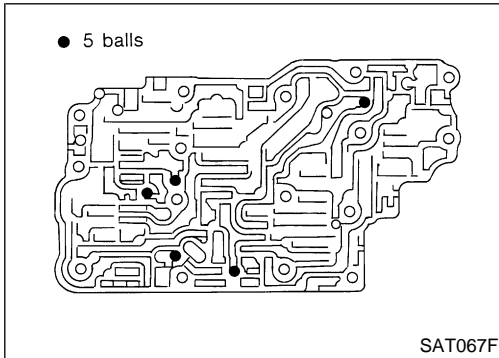

11. Check to see that steel balls are properly positioned in upper body and then remove them.

- Be careful not to lose steel balls.

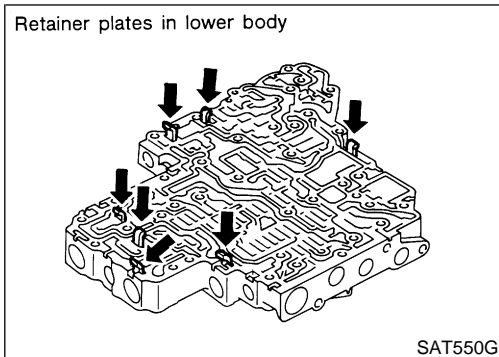

INSPECTION

Lower and Upper Bodies

NDAT0133

NDAT0133S01

- Check to see that retainer plates are properly positioned in lower body.

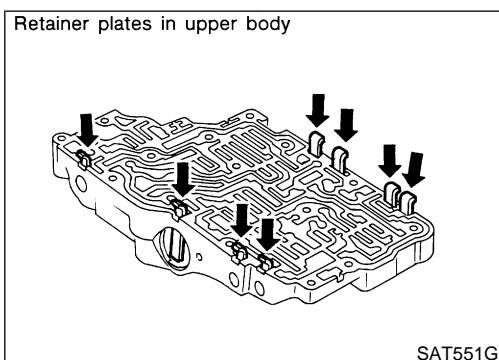

- Check to see that retainer plates are properly positioned in upper body.

- Be careful not to lose these parts.

Oil Strainer

NDAT0133S02

- Check wire netting of oil strainer for damage.

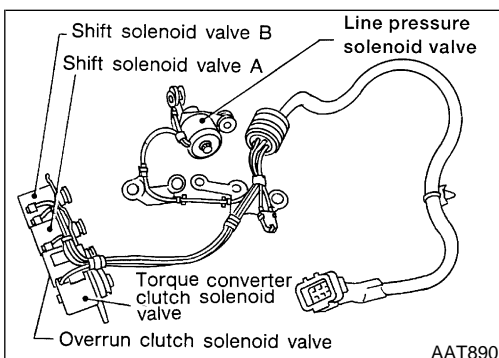

Shift Solenoid Valves "A" and "B", Line Pressure Solenoid Valve, Torque Converter Clutch Solenoid Valve and Overrun Clutch Solenoid Valve

NDAT0133S03

- Measure resistance. Refer to "Component Inspection", AT-153.

GI

MA

EM

LC

EC

FE

AT

AX

SU

BR

ST

RS

BT

HA

SC

EL

IDX

REPAIR FOR COMPONENT PARTS

Control Valve Assembly (Cont'd)

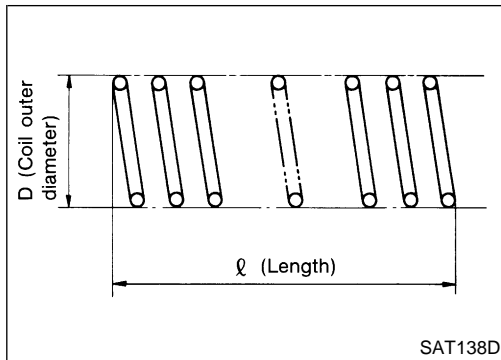

SAT138D

Oil Cooler Relief Valve Spring

NDAT0133S04

- Check springs for damage or deformation.
- Measure free length and outer diameter.

Inspection standard:

Unit: mm (in)

Part No.	l	D
31742-80L12	17.02 (0.6701)	8.0 (0.315)

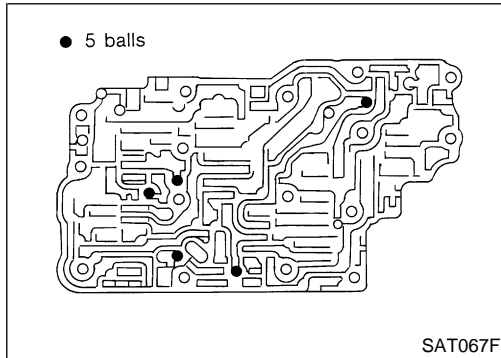

SAT067F

ASSEMBLY

NDAT0134

1. Install upper, inter and lower body.
 - a. Place oil circuit of upper body face up. Install steel balls in their proper positions.

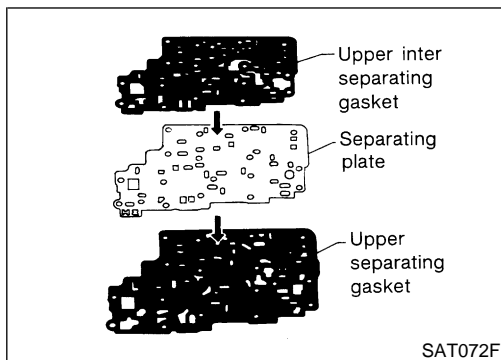

SAT072F

- b. Install upper separating gasket, upper inter separating gasket and upper separating plate in order shown in illustration.

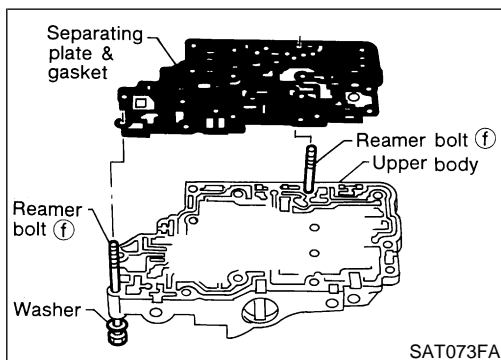

SAT073FA

- c. Install reamer bolts **f** from bottom of upper body. Using reamer bolts as guides, install separating plate and gaskets as a set.

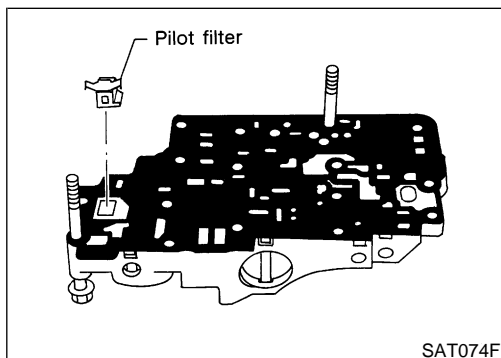

SAT074F

- d. Install pilot filter.

REPAIR FOR COMPONENT PARTS

Control Valve Assembly (Cont'd)

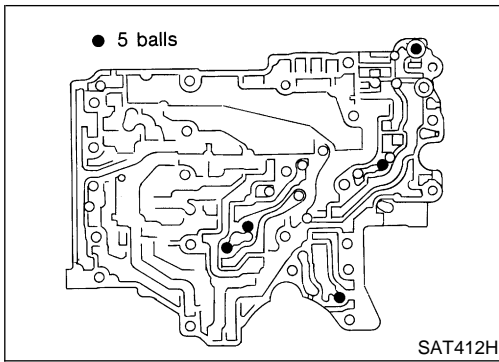

- e. Place lower body as shown in illustration (side of inter body face up). Install steel balls in their proper positions.

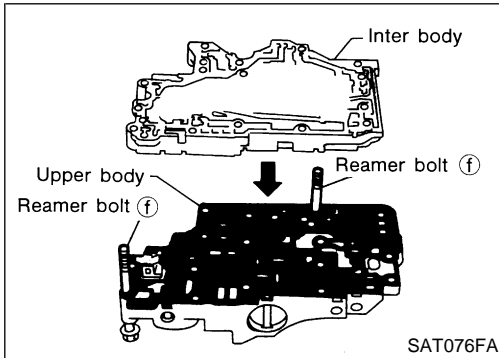

- f. Install inter body on upper body using reamer bolts f as guides.
● **Be careful not to dislocate or drop steel balls.**

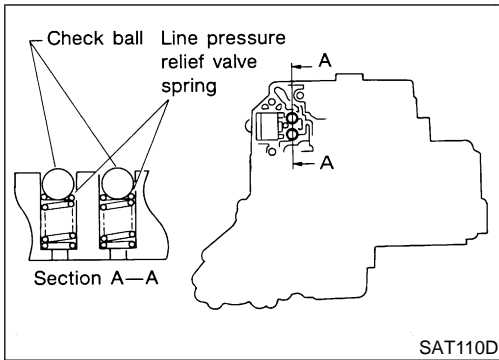

- g. Install steel balls and relief valve springs in their proper positions in lower body.

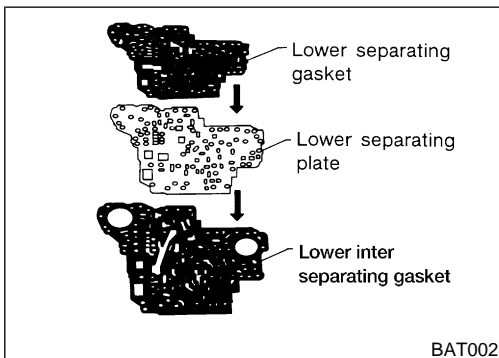

- h. Install lower separating gasket, lower inter separating gasket and lower separating plate in order shown in illustration.

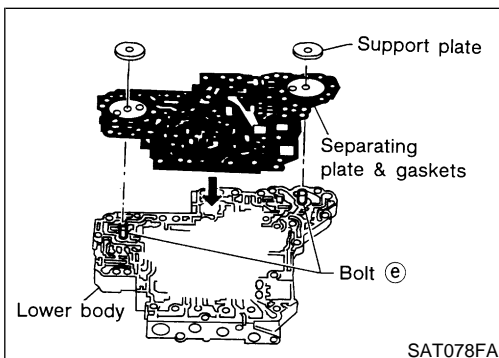

- i. Install bolts e from bottom of lower body. Using bolts e as guides, install separating plate and gaskets as a set.

- j. Temporarily install support plates on lower body.

GI

MA

EM

LC

EC

FE

AT

AX

SU

BR

ST

RS

BT

HA

SC

EL

IDX

REPAIR FOR COMPONENT PARTS

Control Valve Assembly (Cont'd)

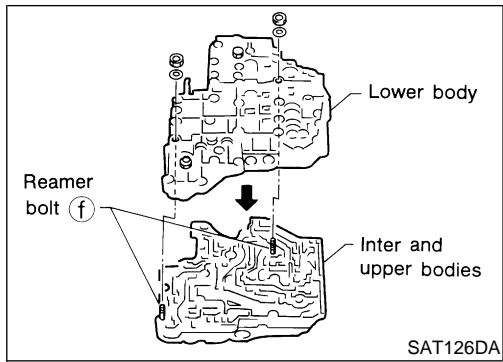

- k. Install lower body on inter body using reamer bolts f as guides and tighten reamer bolts f slightly.

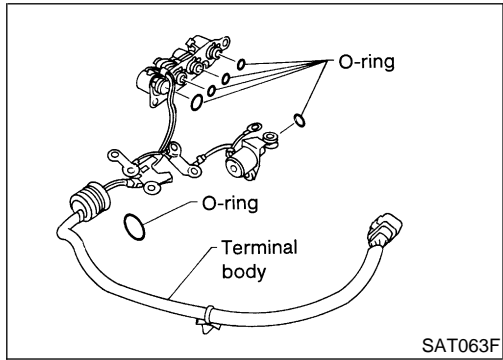

2. Install O-rings to solenoid valves and terminal body.
 • Apply ATF to O-rings.

3. Install and tighten bolts.

Bolt length, number and location:

Bolt symbol	a	b	c	d	e	f	g
Bolt length "ℓ" mm (in)	13.5 (0.531)	58.0 (2.283)	40.0 (1.575)	66.0 (2.598)	33.0 (1.299)	78.0 (3.071)	18.0 (0.709)
							
Number of bolts	6	3	6	11	2	2	1

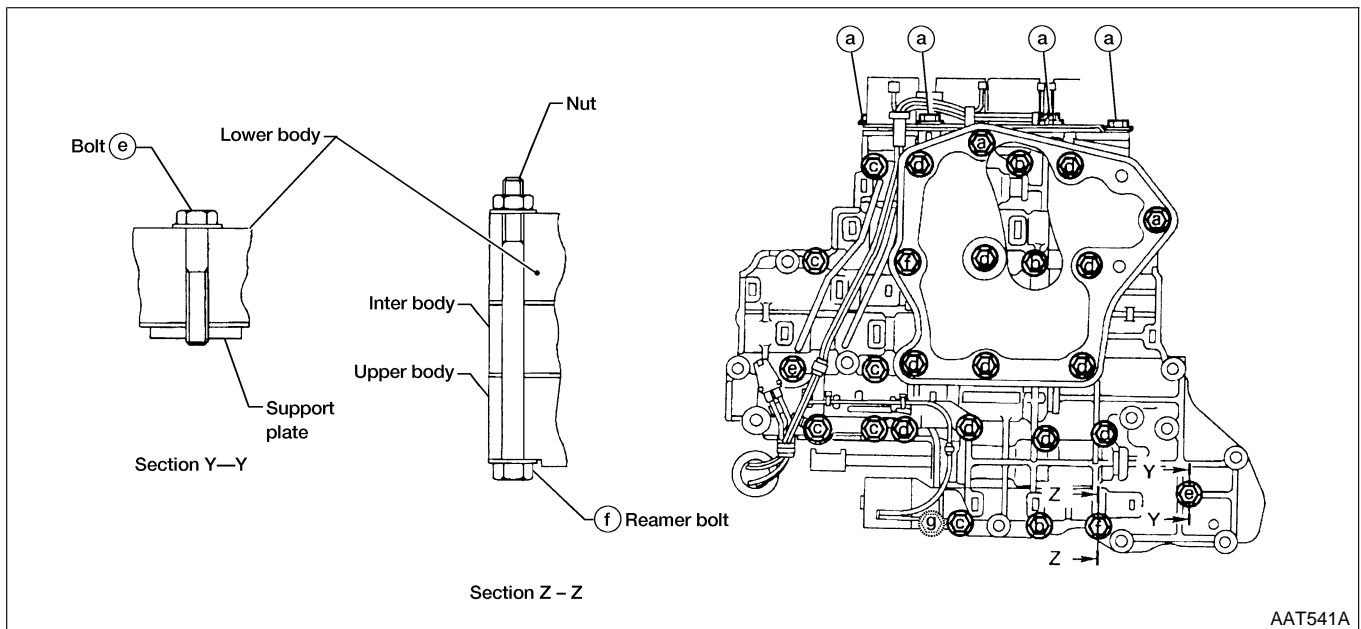

REPAIR FOR COMPONENT PARTS

Control Valve Assembly (Cont'd)

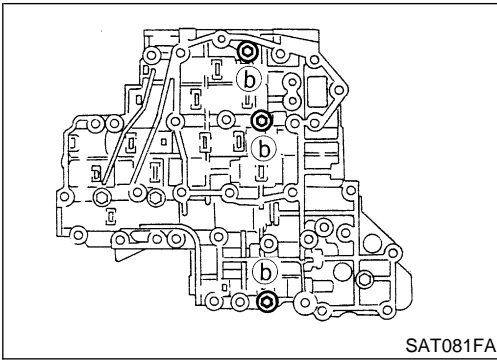

- a. Install and tighten bolts **b** to specified torque.
 : 7 - 9 N·m (0.7 - 0.9 kg·m, 61 - 78 in-lb)

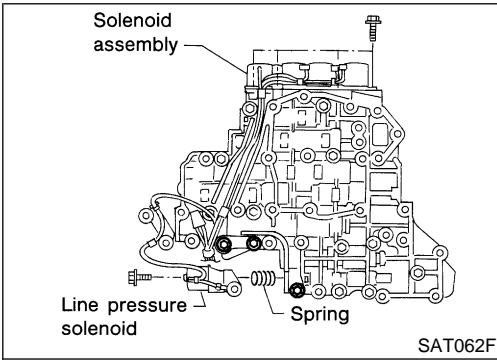

- b. Install solenoid valve assembly and line pressure solenoid valve to lower body.

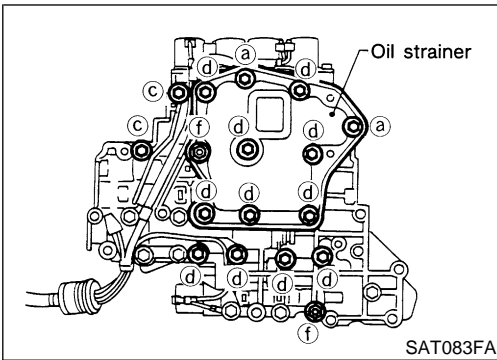

- c. Set oil strainer, then tighten bolts **a**, **c**, **d** and nuts **f** to specified torque.
 : 7 - 9 N·m (0.7 - 0.9 kg·m, 61 - 78 in-lb)

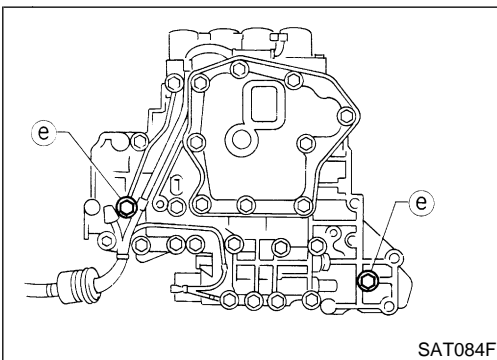

- d. Tighten bolts **e** to specified torque.
 : 3.4 - 4.4 N·m (0.35 - 0.45 kg·m, 30.4 - 39.1 in-lb)

GI

MA

EM

LC

EC

FE

AT

AX

SU

BR

ST

RS

BT

HA

SC

EL

IDX

REPAIR FOR COMPONENT PARTS

Control Valve Upper Body

Control Valve Upper Body COMPONENTS

Apply ATF to all components before installation.

=NDAT0135

SEC. 317

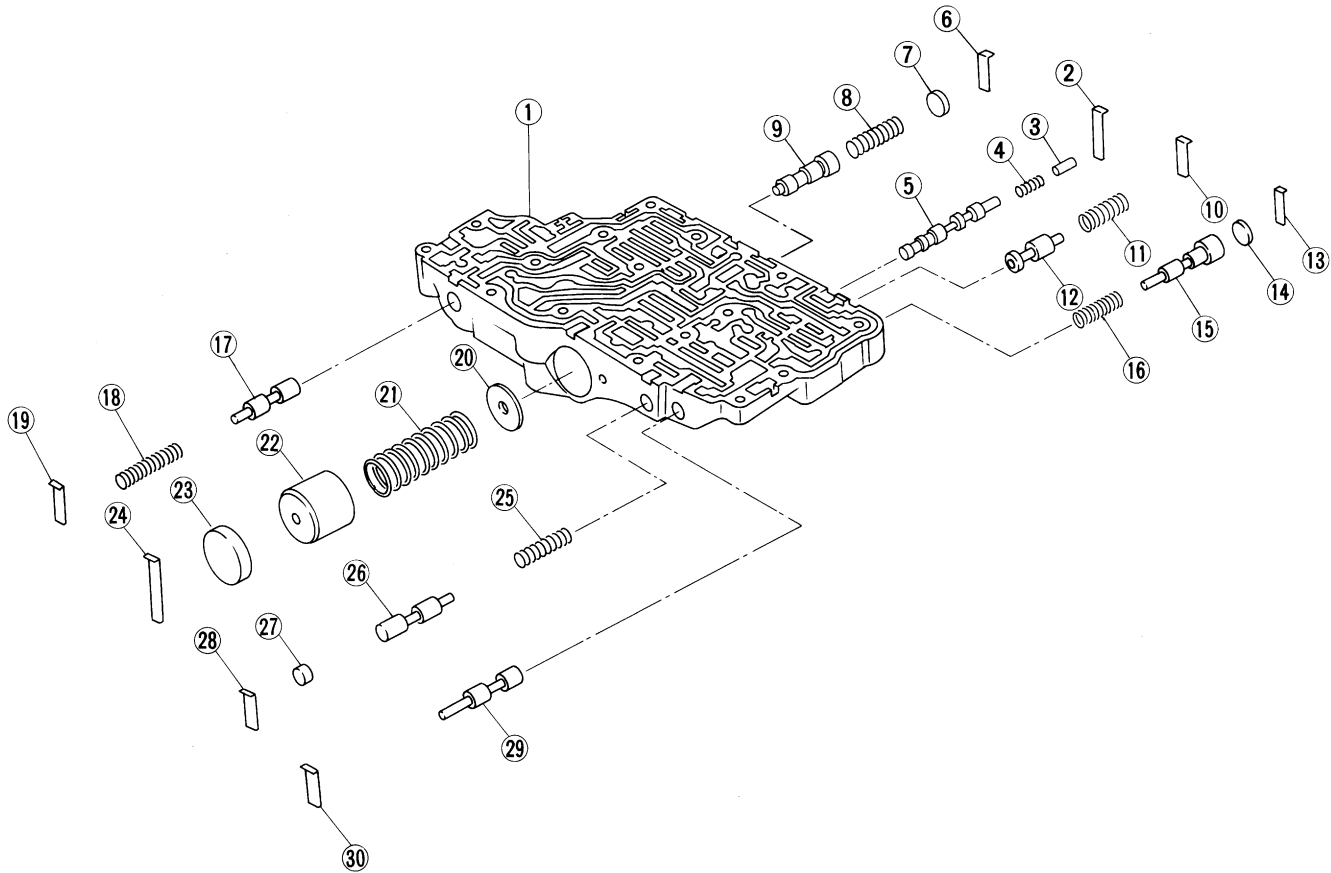

- | | | |
|--|------------------------------------|----------------------------|
| 1. Upper body | 11. Return spring | 21. Return spring |
| 2. Retainer plate | 12. Torque converter relief valve | 22. 1-2 accumulator piston |
| 3. Plug | 13. Retainer plate | 23. Plug |
| 4. Return spring | 14. Plug | 24. Retainer plate |
| 5. Torque converter clutch control valve | 15. Overrun clutch reducing valve | 25. Return spring |
| 6. Retainer plate | 16. Return spring | 26. 1st reducing valve |
| 7. Plug | 17. Pilot valve | 27. Plug |
| 8. Return spring | 18. Return spring | 28. Retainer plate |
| 9. 1-2 accumulator valve | 19. Retainer plate | 29. Plug |
| 10. Retainer plate | 20. 1-2 accumulator retainer plate | 30. Retainer plate |

SAT859H

AT-310

REPAIR FOR COMPONENT PARTS

Control Valve Upper Body (Cont'd)

Retainer plates in upper body

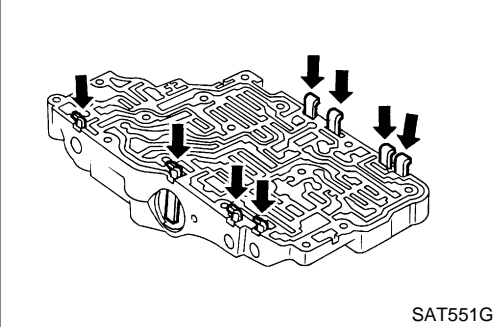

DISASSEMBLY

NDAT0136

1. Remove valves at retainer plates.
 - Do not use a magnetic pick-up tool.

GI

MA

EM

LC

- a. Use a screwdriver to remove retainer plates.

EC

FE

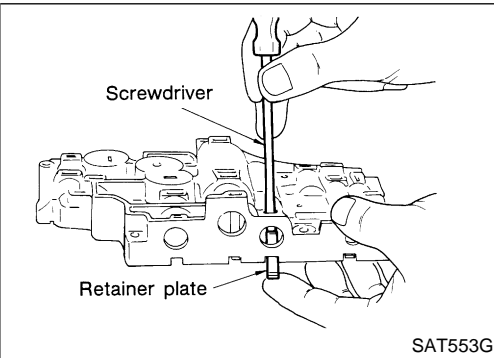

AT

AX

- b. Remove retainer plates while holding spring, plugs or sleeves.

- Remove plugs slowly to prevent internal parts from jumping out.

SU

BR

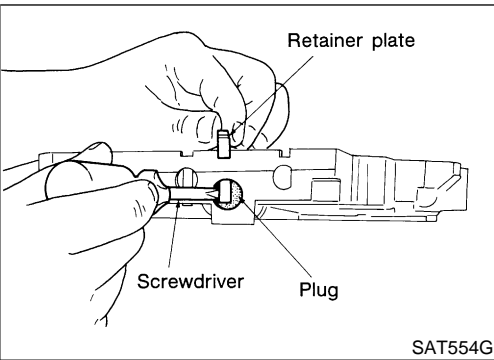

ST

RS

- c. Place mating surface of valve body face down, and remove internal parts.

- If a valve is hard to remove, place valve body face down and lightly tap it with a soft hammer.

BT

- Be careful not to drop or damage valves and sleeves.

HA

SC

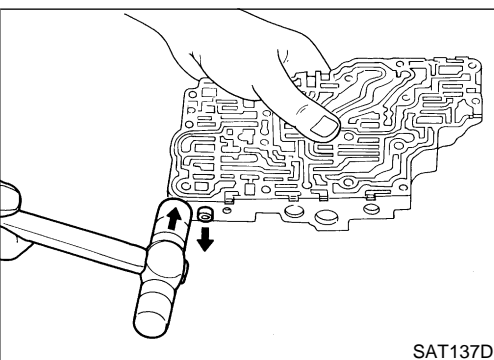

EL

IDX

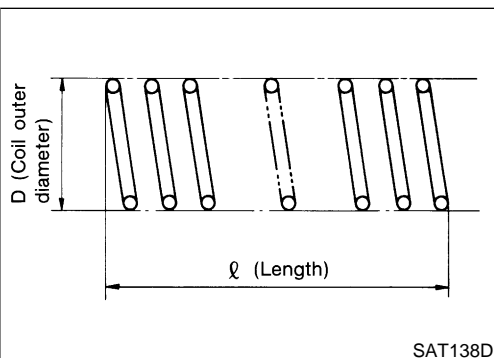

INSPECTION

NDAT0137

Valve Spring

- Measure free length and outer diameter of each valve spring. Also check for damage or deformation.

NDAT0137S01

Inspection standard:

Refer to "CONTROL VALVE AND PLUG RETURN SPRINGS", AT-371.

- Replace valve springs if deformed or fatigued.

Control Valves

NDAT0137S02

- Check sliding surfaces of valves, sleeves and plugs.

REPAIR FOR COMPONENT PARTS

Control Valve Upper Body (Cont'd)

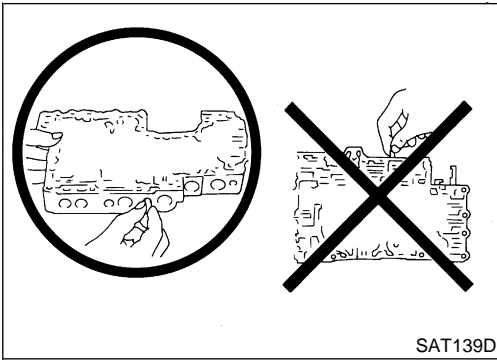

ASSEMBLY

- Lay control valve body down when installing valves. Do not stand the control valve body upright. NDAT0138

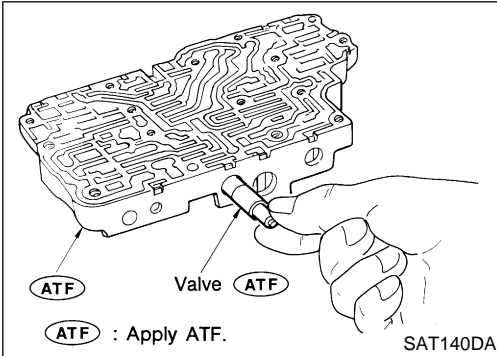

1. Lubricate the control valve body and all valves with ATF. Install control valves by sliding them carefully into their bores.

- Be careful not to scratch or damage valve body.

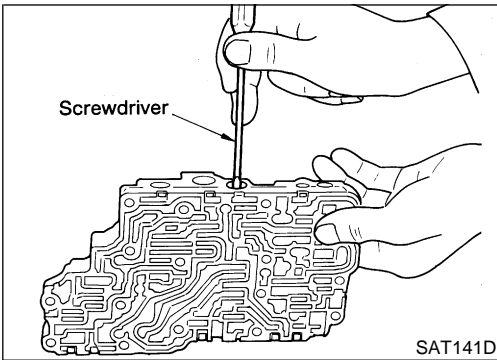

- Wrap a small screwdriver with vinyl tape and use it to insert the valves into their proper positions.

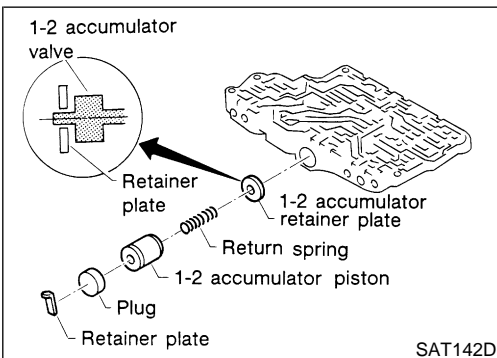

1-2 Accumulator Valve

- Install 1-2 accumulator valve. Align 1-2 accumulator retainer plate from opposite side of control valve body. NDAT0138S01
- Install return spring, 1-2 accumulator piston and plug.

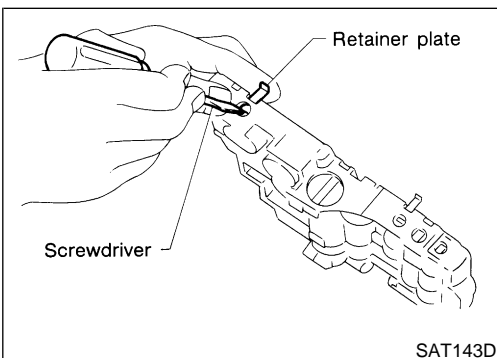

1. Install retainer plates
- While pushing plug or return spring, install retainer plate.

REPAIR FOR COMPONENT PARTS

Control Valve Upper Body (Cont'd)

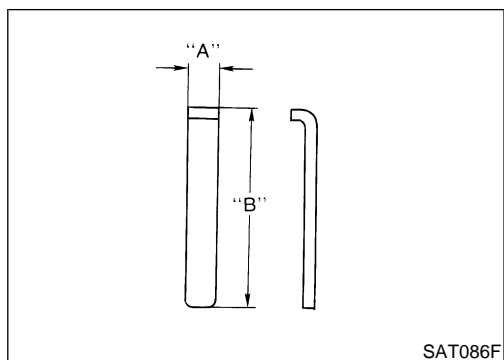

Retainer Plate (Upper body)

Unit: mm (in)

No.	Name of control valve	Width A	Length B
19	Pilot valve	6.0 (0.236)	21.5 (0.846)
28	1st reducing valve		
10	Torque converter relief valve		
30	Plug		
6	1-2 accumulator valve		38.5 (1.516)
24	1-2 accumulator piston valve		
13	Overrun clutch reducing valve		
2	Torque converter clutch control valve		28.0 (1.102)

- Install proper retainer plates.
Refer to "Control Valve Upper Body", AT-310.

GI

MA

EM

LC

EC

FE

AT

AX

SU

BR

ST

RS

BT

HA

SC

EL

IDX

REPAIR FOR COMPONENT PARTS

Control Valve Lower Body

Control Valve Lower Body COMPONENTS

Apply ATF to all components before installation.

=NDAT0139

SEC. 317

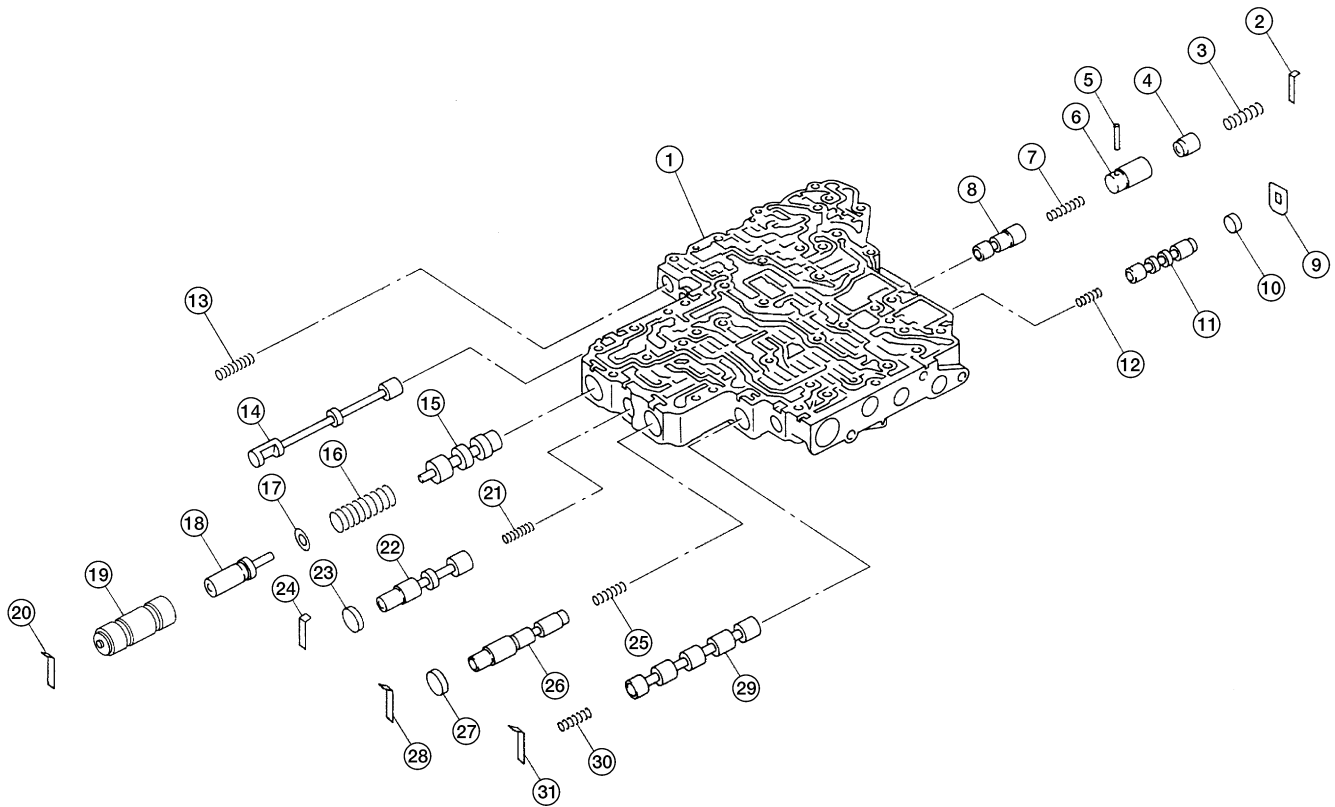

AAT465A

- | | | |
|----------------------------|------------------------------|----------------------------------|
| 1. Lower body | 12. Return spring | 22. Overrun clutch control valve |
| 2. Retainer plate | 13. Return spring | 23. Plug |
| 3. Return spring | 14. Manual valve | 24. Retainer plate |
| 4. Piston | 15. Pressure regulator valve | 25. Return spring |
| 5. Parallel pin | 16. Return spring | 26. Accumulator control valve |
| 6. Sleeve | 17. Spring seat | 27. Plug |
| 7. Return spring | 18. Plug | 28. Retainer plate |
| 8. Pressure modifier valve | 19. Sleeve | 29. Shift valve A |
| 9. Retainer plate | 20. Retainer plate | 30. Retainer spring |
| 10. Plug | 21. Return spring | 31. Retainer plate |
| 11. Shift valve B | | |

REPAIR FOR COMPONENT PARTS

Control Valve Lower Body (Cont'd)

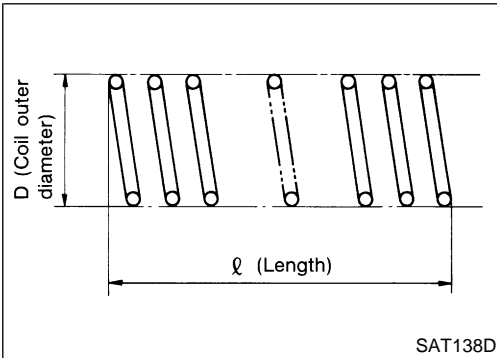
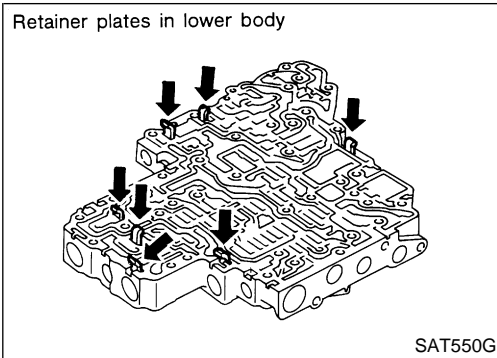

DISASSEMBLY

NDAT0140

- Remove valves at retainer plate.
For removal procedures, refer to "DISASSEMBLY", AT-311.

GI

MA

EM

LC

INSPECTION

NDAT0141

Valve Springs

NDAT0141S01

- Check each valve spring for damage or deformation. Also measure free length and outer diameter.

Inspection standard:

Refer to "CONTROL VALVE AND PLUG RETURN SPRINGS", AT-371.

EC

FE

- Replace valve springs if deformed or fatigued.

AT

Control Valves

NDAT0141S02

- Check sliding surfaces of control valves, sleeves and plugs for damage.

AX

SU

BR

ST

RS

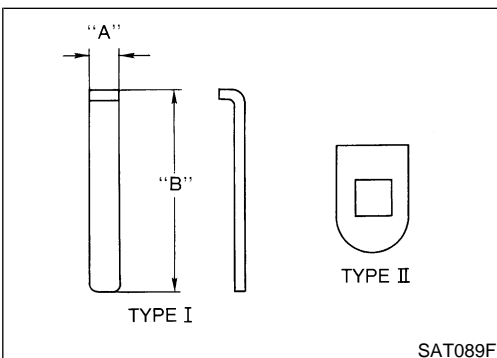
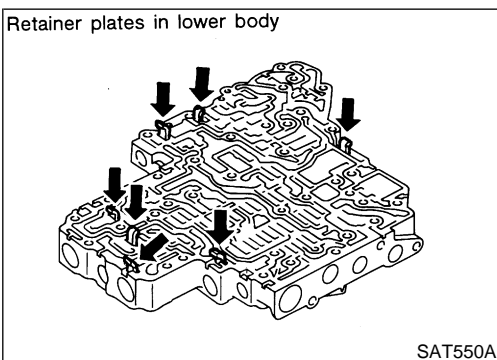

ASSEMBLY

NDAT0142

- Install control valves.
For installation procedures, refer to "ASSEMBLY", AT-312.

BT

HA

SC

EL

IDX

Retainer Plate (Lower body)

NDAT0142S01
Unit: mm (in)

No.	Name of control valve and plug	Width A	Length B	Type
21	Pressure regulator valve	6.0 (0.236)	28.0 (1.102)	I
29	Accumulator control valve			
32	Shift valve A			
25	Overrun clutch control valve			
2	Pressure modifier valve			

REPAIR FOR COMPONENT PARTS

Control Valve Lower Body (Cont'd)

No.	Name of control valve and plug	Width A	Length B	Type
9	Shift valve B	—	—	II

- Install proper retainer plates.
Refer to “Control Valve Lower Body”, AT-314.

Reverse Clutch COMPONENTS

NDAT0143

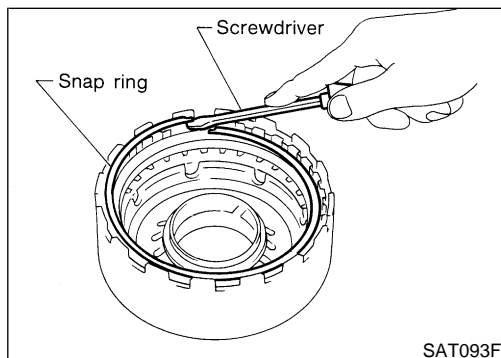
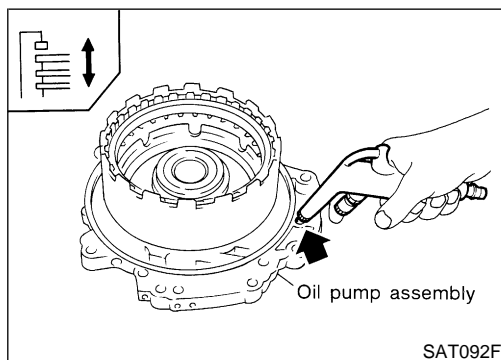
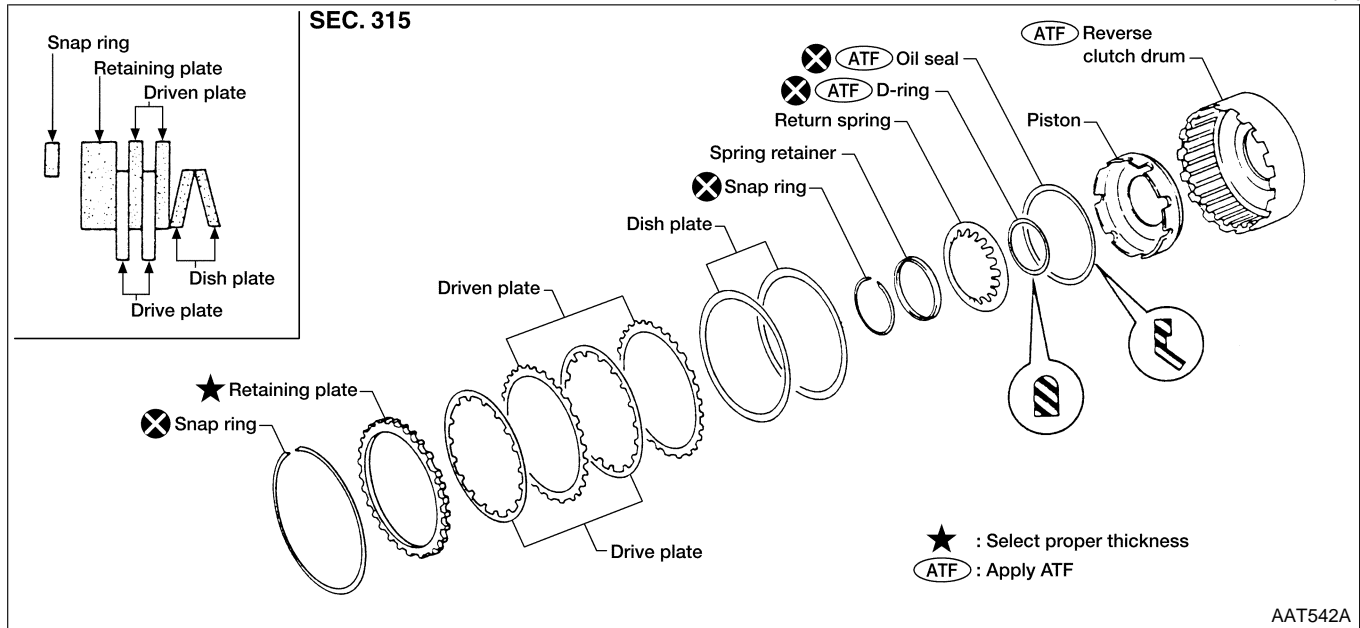

DISASSEMBLY

NDAT0144

1. Check operation of reverse clutch
 - a. Install seal ring onto drum support of oil pump cover and install reverse clutch assembly. Apply compressed air to oil hole.
 - b. Check to see that retaining plate moves to snap ring.
 - c. If retaining plate does not contact snap ring:
 - D-ring might be damaged.
 - Oil seal might be damaged.
 - Fluid might be leaking past piston check ball.
2. Remove snap ring.
3. Remove drive plates, driven plates, retaining plate, and dish plates.

REPAIR FOR COMPONENT PARTS

Reverse Clutch (Cont'd)

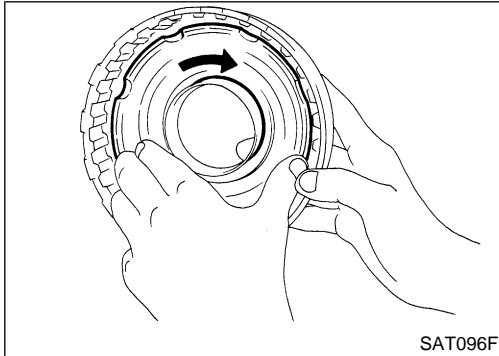
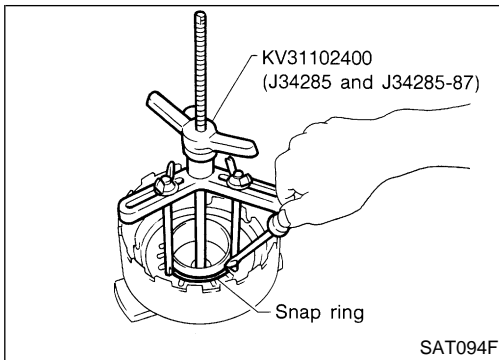

4. Set Tool on spring retainer and remove snap ring from reverse clutch drum while compressing return springs.
 - **Set Tool directly over springs.**
 - **Do not expand snap ring excessively.**
5. Remove spring retainer and return springs.
6. Remove piston from reverse clutch drum by turning it.
7. Remove D-ring and lip seal from piston.

GI

MA

EM

LC

EC

FE

AT

AX

INSPECTION

Reverse Clutch Snap Ring, Spring Retainer and Return Springs

NDAT0145

SU

NDAT0145S01

- Check for deformation, fatigue or damage. If necessary, replace.

BR

ST

RS

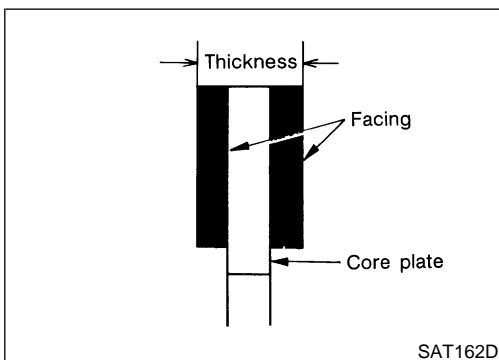

Reverse Clutch Drive Plates

NDAT0145S02

BT

- Check facing for burns, cracks or damage.
- Measure thickness of facing.
 - Thickness of drive plate:**
 - Standard value: 1.6 mm (0.063 in)**
 - Wear limit: 1.4 mm (0.055 in)**
- If not within wear limit, replace.

HA

SC

EL

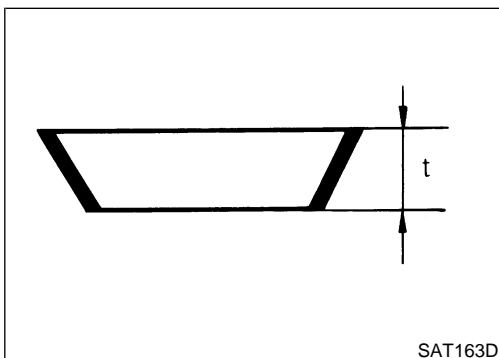

Reverse Clutch Dish Plates

NDAT0145S03

IDX

- Check for deformation or damage.
- Measure thickness of dish plate.
 - Thickness of dish plate: 3.08 mm (0.1213 in)**
- If deformed or fatigued, replace.

Reverse Clutch Piston

NDAT0145S04

- Make sure that check balls are not fixed.
- Apply compressed air to check ball oil hole opposite the return spring. Make sure there is no air leakage.

REPAIR FOR COMPONENT PARTS

Reverse Clutch (Cont'd)

- Apply compressed air to oil hole on return spring side to make sure that air leaks past ball.

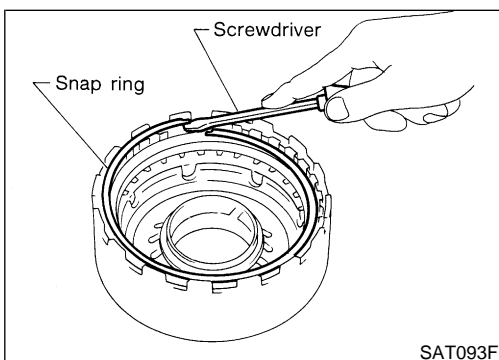
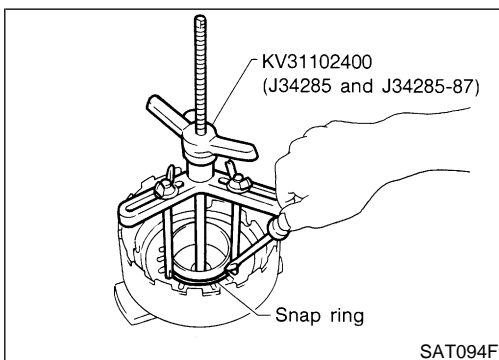
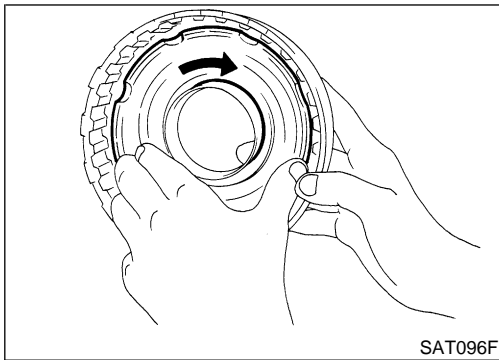
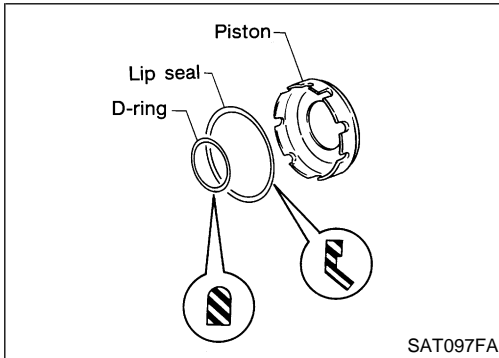

ASSEMBLY

NDAT0146

1. Install D-ring and lip seal on piston.
 - **Take care with the direction of lip seal.**
 - **Apply ATF to both parts.**
2. Install piston assembly by turning it slowly.
 - **Apply ATF to inner surface of drum.**
3. Install return springs and spring retainer on piston.
4. Set Tool on spring retainer and install snap ring while compressing return springs.
 - **Set Tool directly over return springs.**
5. Install drive plates, driven plates, retaining plate and dish plates.
 - **Take care with order of plates.**
6. Install snap ring.

REPAIR FOR COMPONENT PARTS

Reverse Clutch (Cont'd)

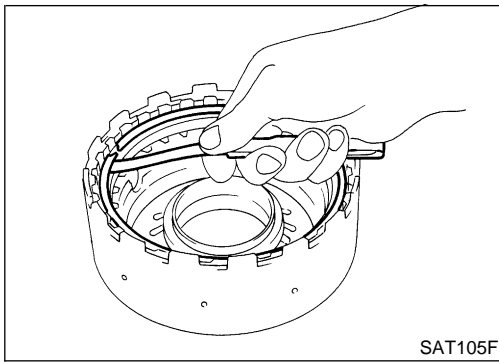

7. Measure clearance between retaining plate and snap ring. If not within allowable limit, select proper retaining plate.

Specified clearance:

Standard 0.5 - 0.8 mm (0.020 - 0.031 in)

Allowable limit 1.2 mm (0.047 in)

Retaining plate:

Refer to "REVERSE CLUTCH", AT-372.

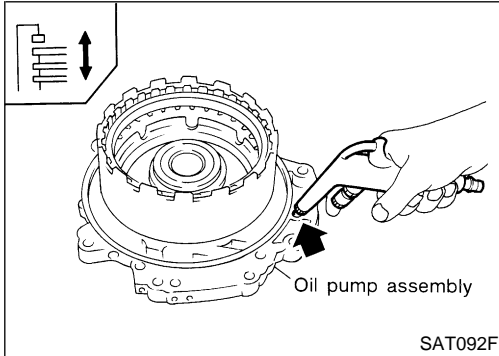

8. Check operation of reverse clutch. Refer to "DISASSEMBLY", AT-316.

High Clutch COMPONENTS

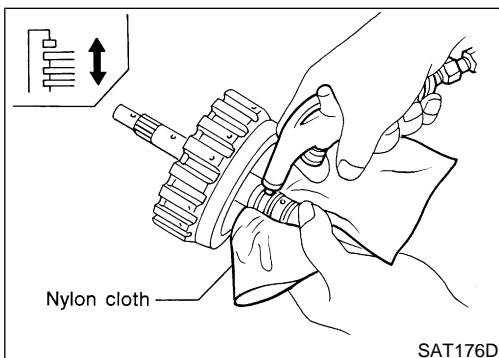
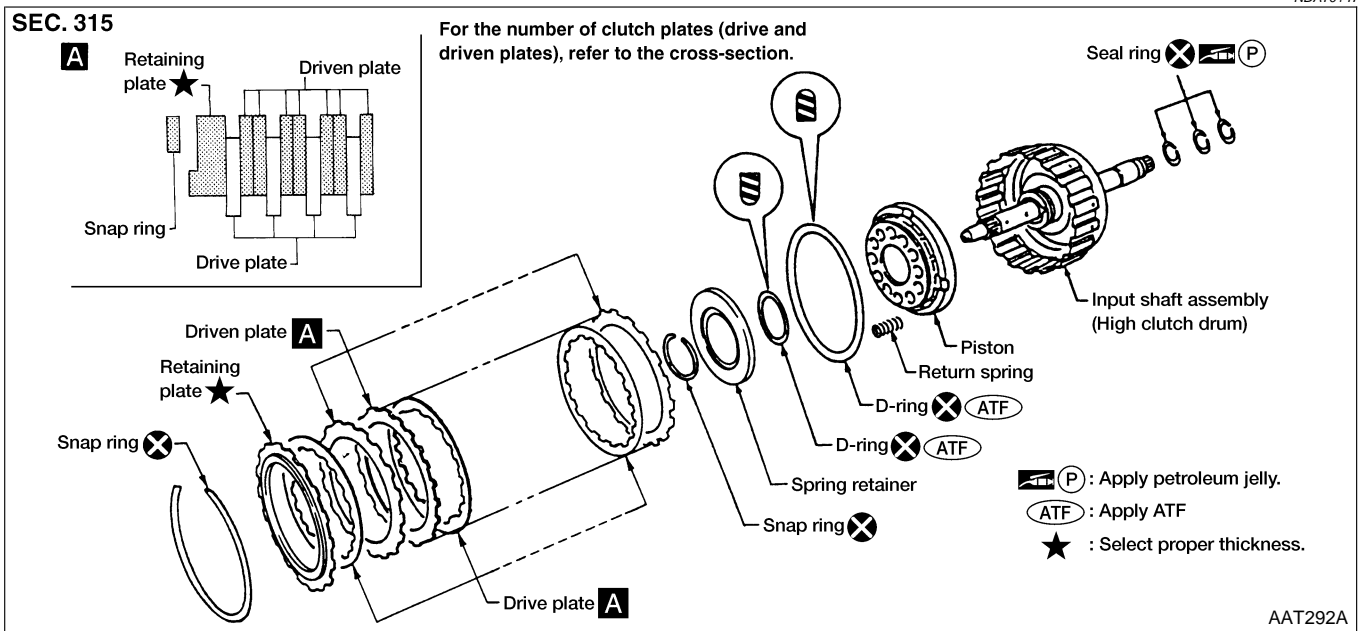

DISASSEMBLY

1. Check operation of high clutch.
 - a. Apply compressed air to oil hole of input shaft with nylon cloth.
 - **Stop up hole on opposite side of input shaft with nylon cloth.**
 - b. Check to see that retaining plate moves to snap ring.
 - c. If retaining plate does not contact snap ring:
 - D-ring might be damaged.
 - Oil seal might be damaged.
 - Fluid might be leaking past piston check ball.

GI

MA

EM

LC

EC

FE

AT

AX

SU

BR

ST

RS

BT

HA

SC

EL

IDX

REPAIR FOR COMPONENT PARTS

High Clutch (Cont'd)

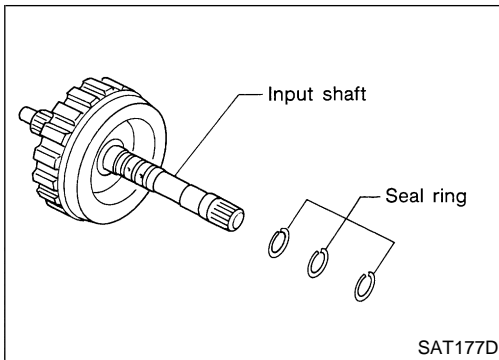

2. Remove seal rings from input shaft.
 - **Always replace when removed.**

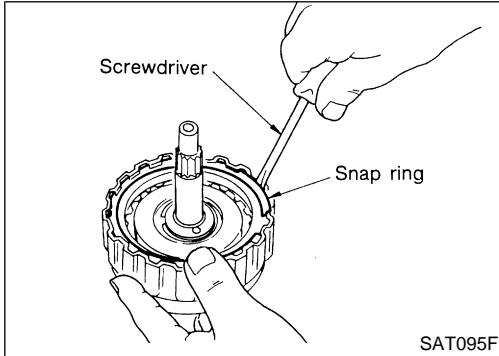

3. Remove snap ring.
4. Remove drive plates, driven plates and retaining plate.

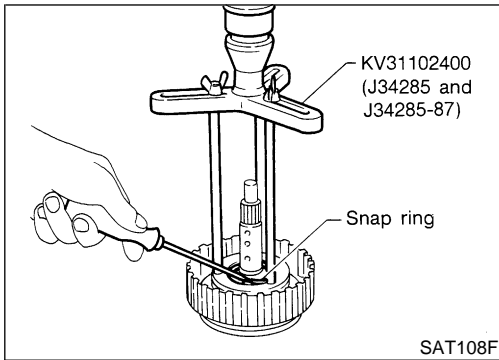

5. Set Tool on spring retainer and remove snap ring from high clutch drum while compressing return springs.
 - **Set Tool directly over springs.**
 - **Do not expand snap ring excessively.**
6. Remove spring retainer and return springs.

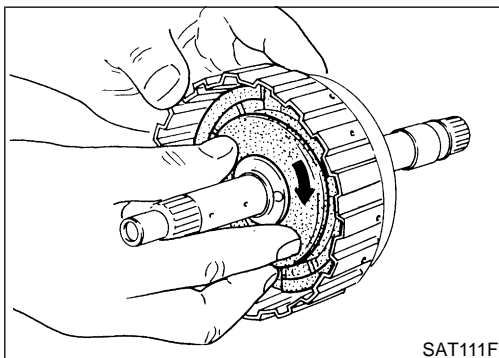

7. Remove piston from high clutch drum by turning it.

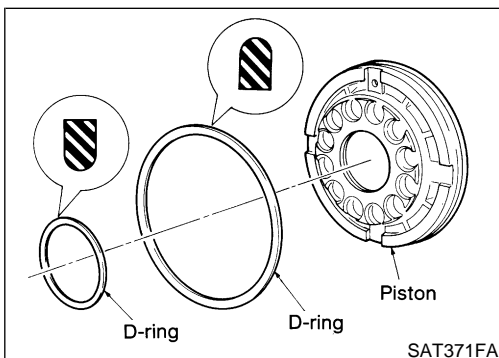

8. Remove D-rings from piston.

INSPECTION

High Clutch Snap Ring, Spring Retainer and Return Springs

NDAT0149

NDAT0149S01

- Check for deformation, fatigue or damage. If necessary, replace.
- **When replacing spring retainer and return springs, replace them as a set.**

GI

MA

EM

LC

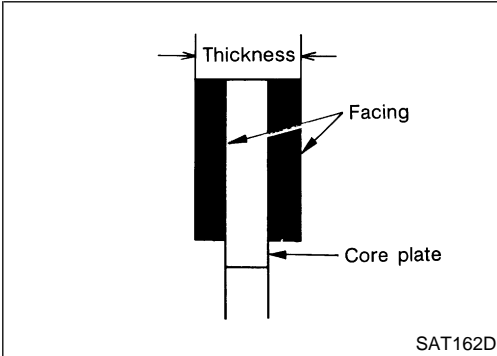

SAT162D

High Clutch Drive Plates

NDAT0149S02

- Check facing for burns, cracks or damage.
- Measure thickness of facing.

Thickness of drive plate:

Standard value 1.6 mm (0.063 in)

Wear limit 1.4 mm (0.055 in)

- If not within wear limit, replace.

EC

FE

AT

AX

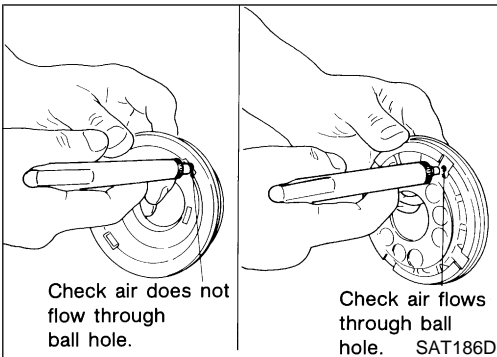

High Clutch Piston

NDAT0149S03

- Make sure that check balls are not fixed.
- Apply compressed air to check ball oil hole opposite the return spring. Make sure there is no air leakage.
- Apply compressed air to oil hole on return spring side to make sure that air leaks past ball.

SU

BR

ST

RS

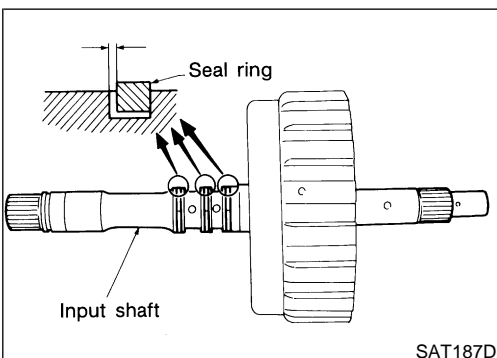

Seal Ring Clearance

NDAT0149S04

- Install new seal rings onto input shaft.
- Measure clearance between seal ring and ring groove.

Standard clearance:

0.08 - 0.23 mm (0.0031 - 0.0091 in)

Allowable limit:

0.23 mm (0.0091 in)

- If not within allowable limit, replace input shaft assembly.

BT

HA

SC

EL

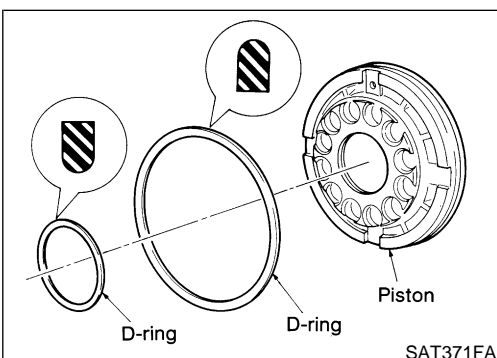

ASSEMBLY

NDAT0150

1. Install D-rings on piston.
- **Apply ATF to both parts.**

IDX

REPAIR FOR COMPONENT PARTS

High Clutch (Cont'd)

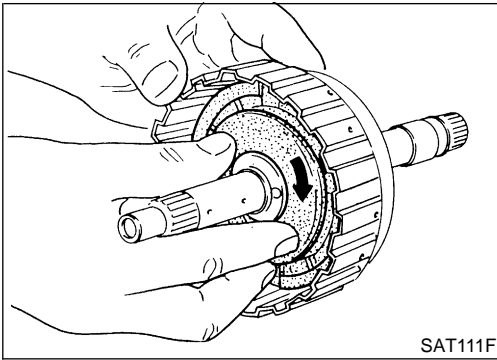

2. Install piston assembly by turning it slowly.
 - **Apply ATF to inner surface of drum.**

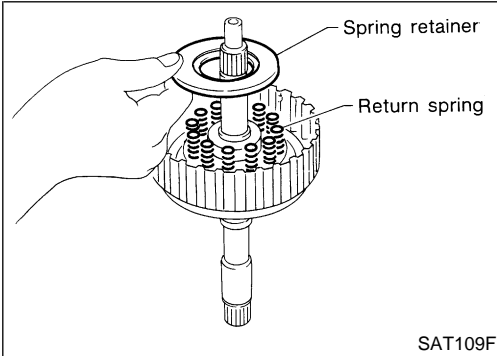

3. Install return springs and spring retainer on piston.

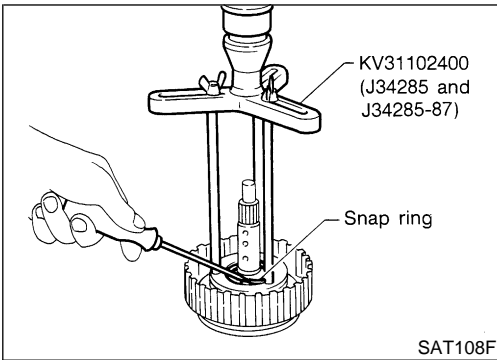

4. Set Tool on spring retainer and install snap ring while compressing return springs.
 - **Set Tool directly over return springs.**

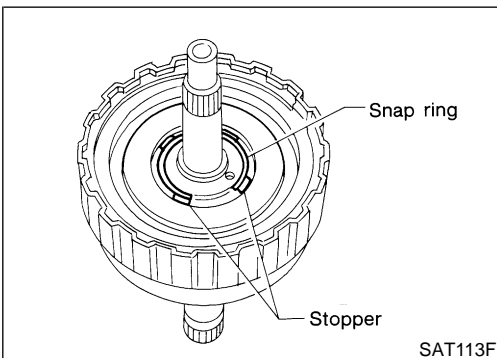

- **Do not align snap ring gap with spring retainer stopper.**

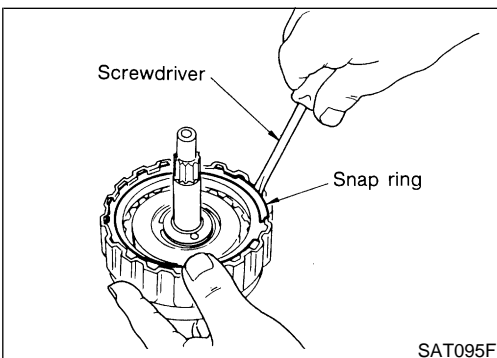

5. Install drive plates, driven plates and retaining plate.
 - **Take care with the order and direction of plates.**
6. Install snap ring.

REPAIR FOR COMPONENT PARTS

High Clutch (Cont'd)

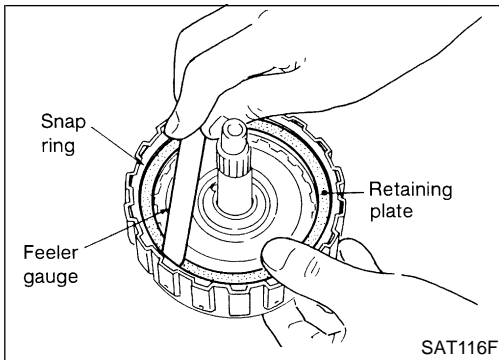

7. Measure clearance between retaining plate and snap ring. If not within allowable limit, select proper retaining plate.

Specified clearance:

Standard 1.8 - 2.2 mm (0.071 - 0.087 in)

Allowable limit 2.8 mm (0.110 in)

Retaining plate:

Refer to "HIGH CLUTCH", AT-372.

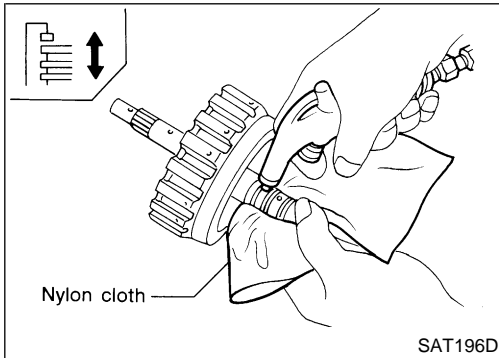

8. Check operation of high clutch.
Refer to "DISASSEMBLY", AT-319.

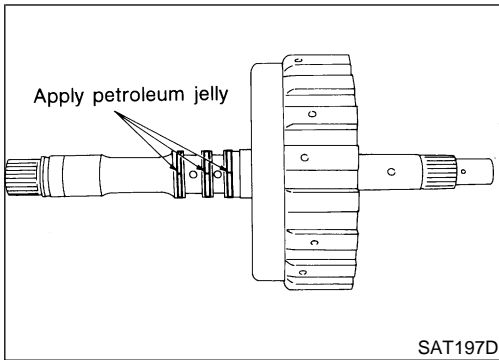

9. Install seal rings to input shaft.
 - **Apply petroleum jelly to seal rings.**
 - **Always replace when removed.**

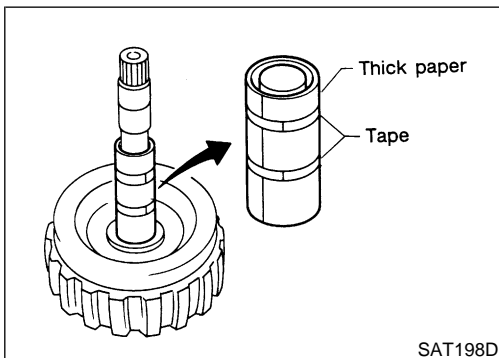

- **Roll paper around seal rings to prevent seal rings from spreading.**

GI

MA

EM

LC

EC

FE

AT

AX

SU

BR

ST

RS

BT

HA

SC

EL

IDX

REPAIR FOR COMPONENT PARTS

Forward and Overrun Clutches

Forward and Overrun Clutches COMPONENTS

NDAT0151

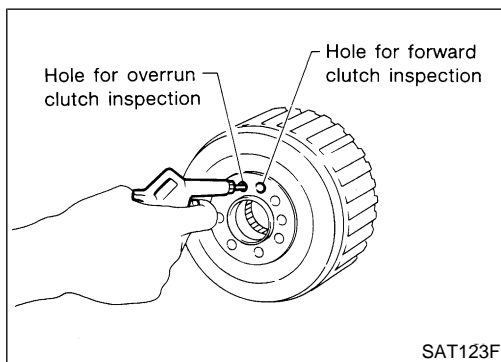
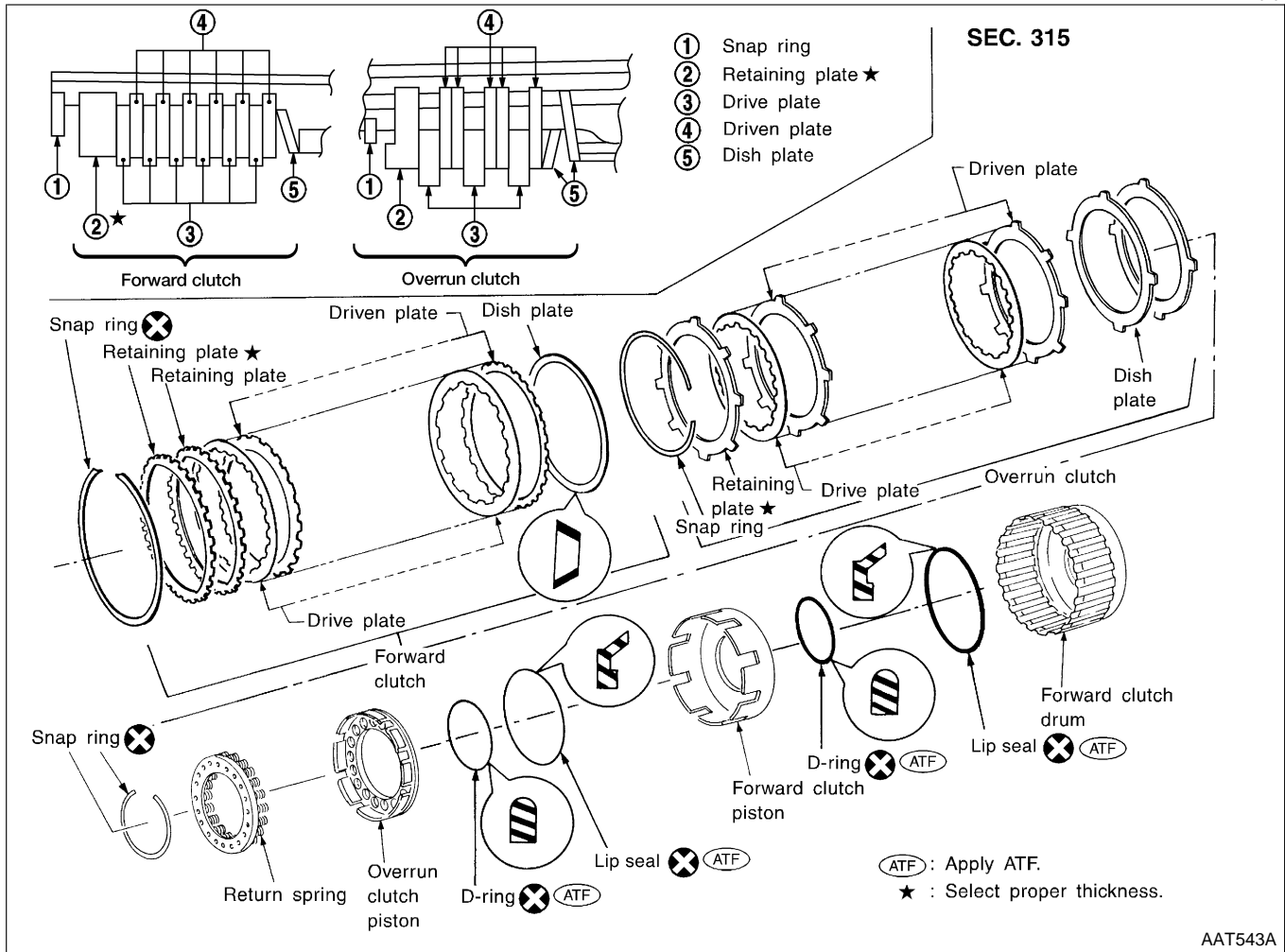

DISASSEMBLY

NDAT0152

1. Check operation of forward clutch and overrun clutch.
 - a. Install bearing retainer on forward clutch drum.
 - b. Apply compressed air to oil hole of forward clutch drum.
 - c. Check to see that retaining plate moves to snap ring.
 - d. If retaining plate does not contact snap ring:
 - D-ring might be damaged.
 - Oil seal might be damaged.
 - Fluid might be leaking past piston check ball.

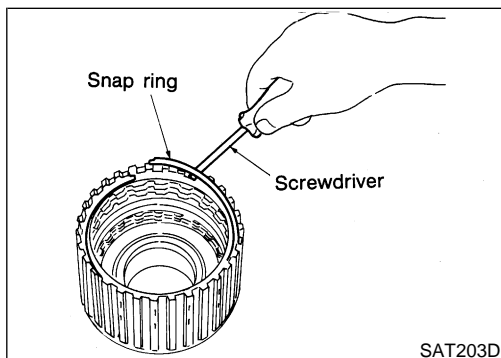

2. Remove snap ring for forward clutch.
3. Remove drive plates, driven plates, retaining plate and dish plate for forward clutch.

REPAIR FOR COMPONENT PARTS

Forward and Overrun Clutches (Cont'd)

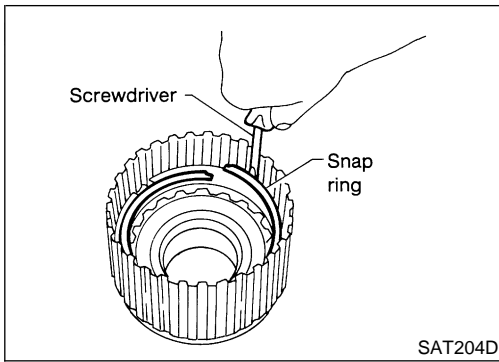

4. Remove snap ring for overrun clutch.
5. Remove drive plates, driven plates, retaining plate and dish plate for overrun clutch.

GI

MA

EM

LC

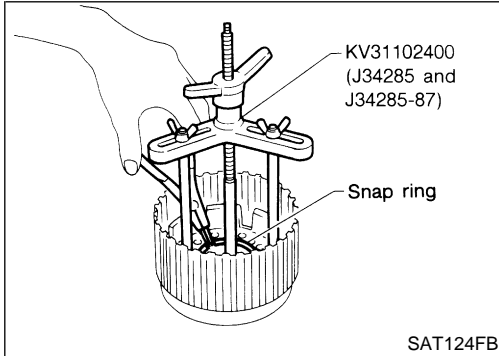

6. Set Tool on spring retainer and remove snap ring from forward clutch drum while compressing return springs.
 - **Set Tool directly over return springs.**
 - **Do not expand snap ring excessively.**
7. Remove spring retainer and return springs.
 - **Do not remove return springs from spring retainer.**

EC

FE

AT

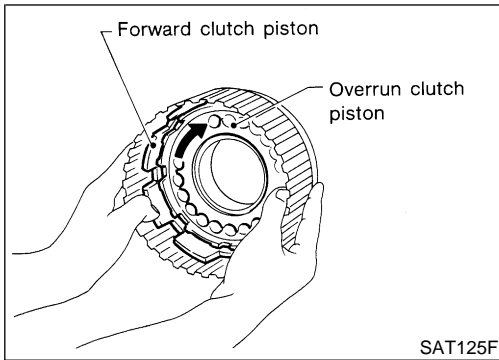

8. Remove forward clutch piston with overrun clutch piston from forward clutch drum by turning it.

AX

SU

BR

ST

RS

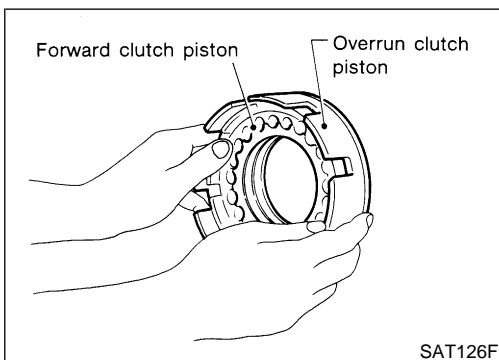

9. Remove overrun clutch piston from forward clutch piston by turning it.

BT

HA

SC

EL

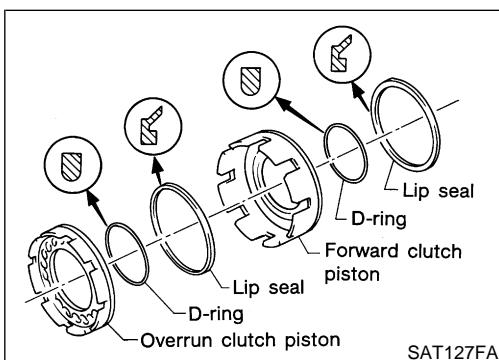

10. Remove D-rings and lip seals from forward clutch piston and overrun clutch piston.

IDX

REPAIR FOR COMPONENT PARTS

Forward and Overrun Clutches (Cont'd)

INSPECTION

Snap Rings, Spring Retainer and Return Springs

NDAT0153

NDAT0153S01

- Check for deformation, fatigue or damage.
- Replace if necessary.
- **When replacing spring retainer and return springs, replace them as a set.**

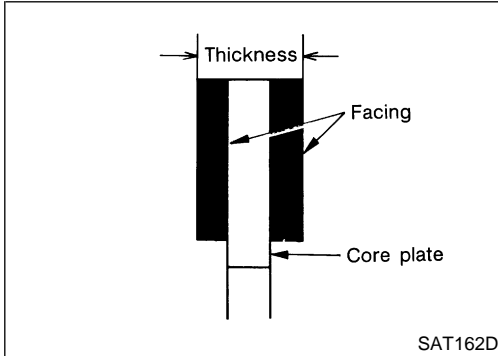

Forward Clutch and Overrun Clutch Drive Plates

NDAT0153S02

- Check facing for burns, cracks or damage.
- Measure thickness of facing.

Thickness of drive plate:

Forward clutch

Standard value: 1.6 mm (0.063 in)

Wear limit: 1.4 mm (0.055 in)

Overrun clutch

Standard value: 1.6 mm (0.063 in)

Wear limit: 1.4 mm (0.055 in)

- If not within wear limit, replace.

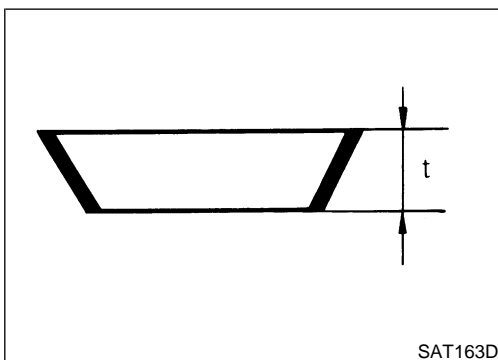

Forward Clutch and Overrun Clutch Dish Plates

NDAT0153S03

- Check for deformation or damage.
- Measure thickness of dish plate.

Thickness of dish plate:

Forward clutch 2.7 mm (0.106 in)

Overrun clutch 2.7 mm (0.106 in)

- If deformed or fatigued, replace.

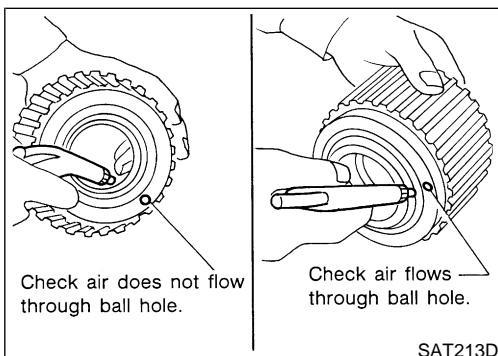

Forward Clutch Drum

NDAT0153S04

- Make sure that check balls are not fixed.
- Apply compressed air to check ball oil hole from outside of forward clutch drum. Make sure air leaks past ball.
- Apply compressed air to oil hole from inside of forward clutch drum. Make sure there is no air leakage.

REPAIR FOR COMPONENT PARTS

Forward and Overrun Clutches (Cont'd)

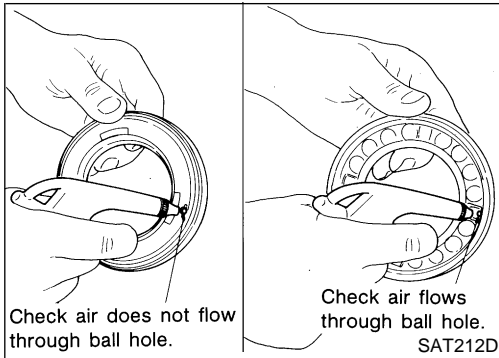

Overrun Clutch Piston

NDAT0153S05

- Make sure that check balls are not fixed.
- Apply compressed air to check ball oil hole opposite the return spring. Make sure there is no air leakage.
- Apply compressed air to oil hole on return spring side. Make sure that air leaks past ball.

GI

MA

EM

LC

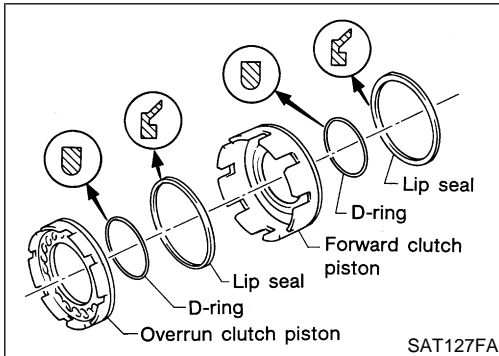

ASSEMBLY

NDAT0154

1. Install D-rings and lip seals on forward clutch piston and overrun clutch piston.
 - Take care with direction of lip seal.
 - Apply ATF to both parts.

EC

FE

AT

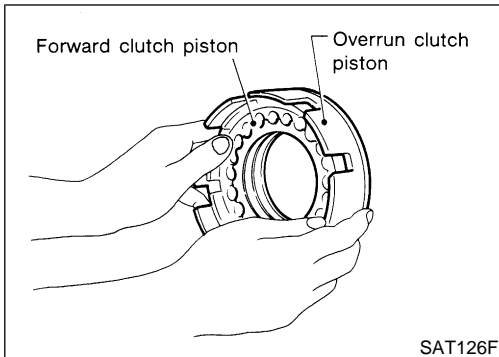

2. Install overrun clutch piston assembly on forward clutch piston by turning it slowly.
 - Apply ATF to inner surface of forward clutch piston.

AX

SU

BR

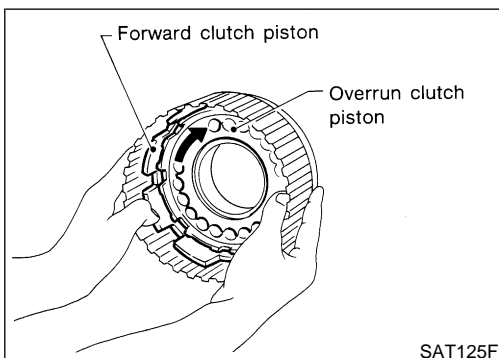

3. Install forward clutch piston assembly on forward clutch drum by turning it slowly.
 - Apply ATF to inner surface of drum.

ST

RS

BT

HA

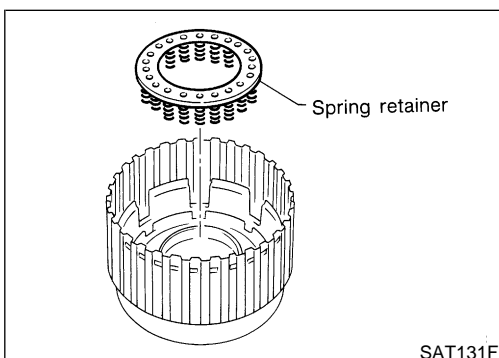

4. Install return spring on overrun clutch piston.

SC

EL

IDX

REPAIR FOR COMPONENT PARTS

Forward and Overrun Clutches (Cont'd)

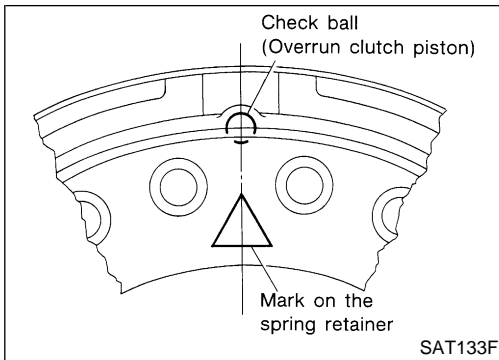

- Align the mark on spring retainer with check ball in overrun clutch piston.

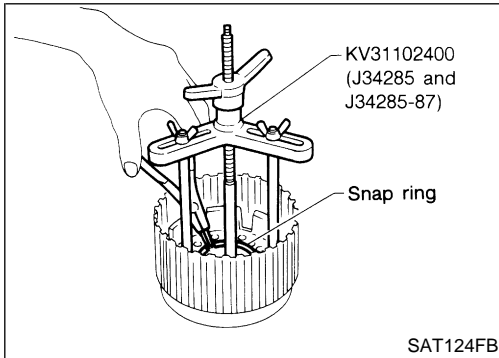

5. Set Tool on spring retainer and install snap ring while compressing return springs.

- **Set Tool directly over return springs.**

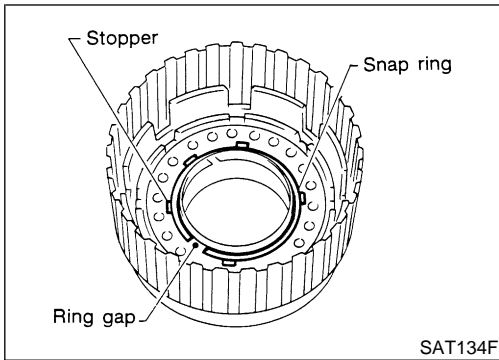

- **Do not align snap ring gap with spring retainer stopper.**

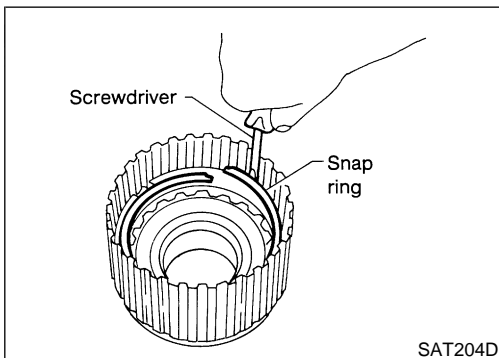

6. Install drive plates, driven plates, retaining plate and dish plate for overrun clutch.

- **Take care with order of plates.**

7. Install snap ring for overrun clutch.

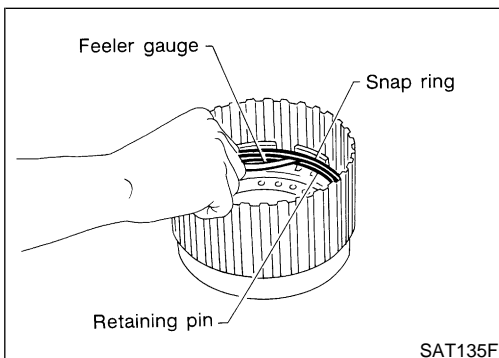

8. Measure clearance between overrun clutch retaining plate and snap ring.

If not within allowable limit, select proper retaining plate.

Specified clearance:

Standard 0.7 - 1.1 mm (0.028 - 0.043 in)

Allowable limit 1.7 mm (0.067 in)

Overrun clutch retaining plate:

Refer to "OVERRUN CLUTCH", AT-373.

REPAIR FOR COMPONENT PARTS

Forward and Overrun Clutches (Cont'd)

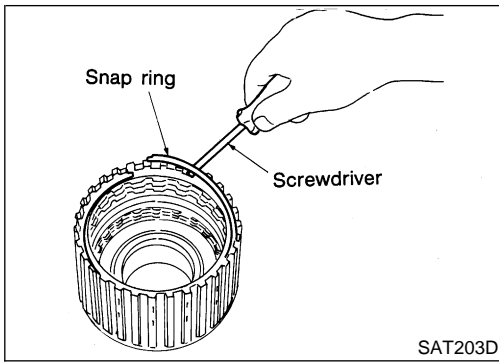

9. Install drive plates, driven plates, retaining plate and dish plate for forward clutch.

● **Take care with order of plates.**

10. Install snap ring for forward clutch.

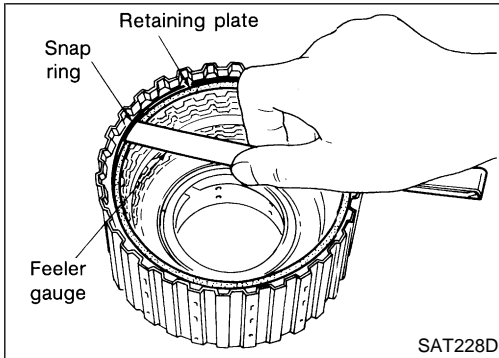

11. Measure clearance between forward clutch retaining plate and snap ring.

If not within allowable limit, select proper retaining plate.

Specified clearance:

Standard 0.45 - 0.85 mm (0.0177 - 0.0335 in)

Allowable limit 1.85 mm (0.0728 in)

Forward clutch retaining plate:

Refer to "FORWARD CLUTCH", AT-372.

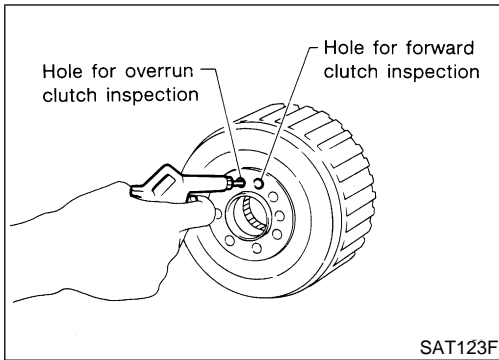

12. Check operation of forward clutch. Refer to "DISASSEMBLY", AT-324.

13. Check operation of overrun clutch. Refer to "DISASSEMBLY", AT-324.

Low & Reverse Brake COMPONENTS

NDAT0155

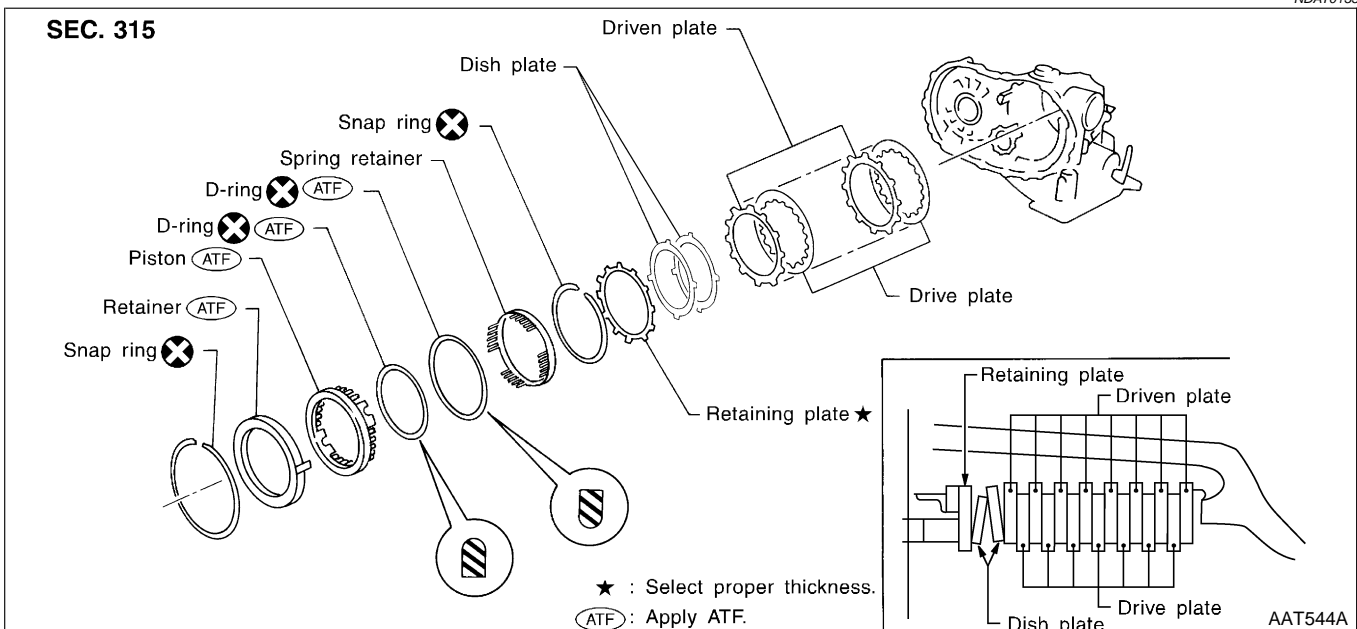

GI

MA

EM

LC

EC

FE

AT

AX

SU

BR

ST

RS

BT

HA

SC

EL

IDX

REPAIR FOR COMPONENT PARTS

Low & Reverse Brake (Cont'd)

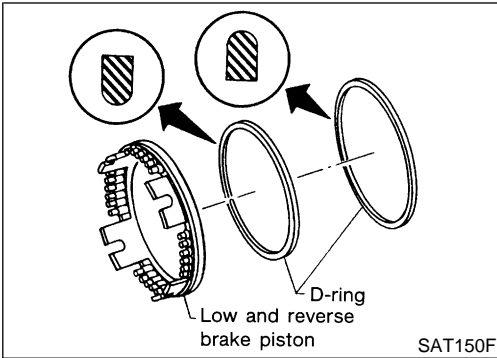
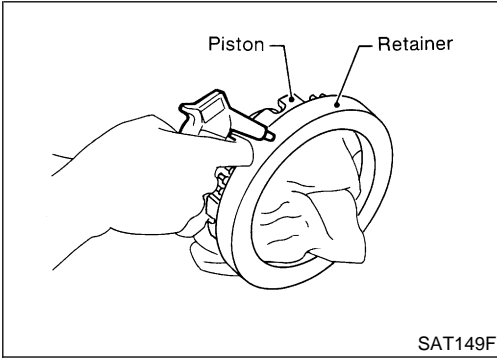
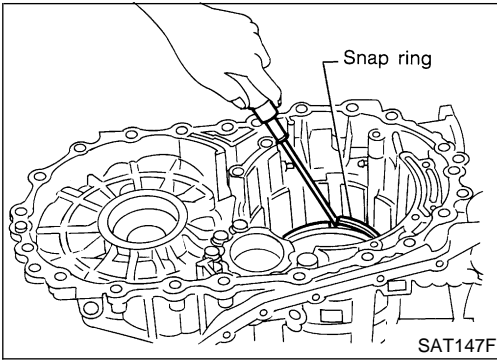

DISASSEMBLY

NDAT0156

1. Check operation of low & reverse brake.
 - a. Apply compressed air to oil hole of transmission case.
 - b. Check to see that retaining plate moves to snap ring.
 - c. If retaining plate does not contact snap ring:
 - D-ring might be damaged.
 - Fluid might be leaking past piston check ball.
2. In order to remove piston, apply compressed air to oil hole of retainer while holding piston.
 - **Apply air gradually and allow piston to come out evenly.**
3. Remove D-rings from piston.

INSPECTION

NDAT0157

Low and Reverse Brake Snap Ring, Spring Retainer and Return Springs

NDAT0157S01

- Check for deformation, fatigue or damage. If necessary, replace.
- **When replacing spring retainer and return springs, replace them as a set.**

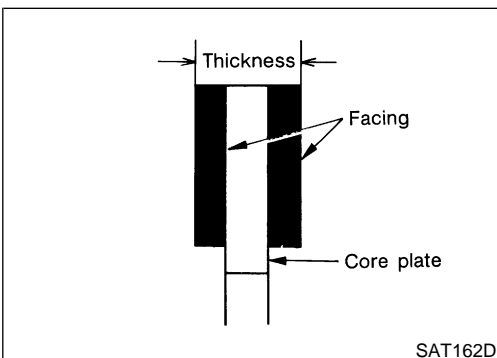

Low and Reverse Brake Drive Plate

NDAT0157S02

- Check facing for burns, cracks or damage.
- Measure thickness of facing.
 - Thickness of drive plate:**
 - Standard value 1.8 mm (0.071 in)**
 - Wear limit 1.6 mm (0.063 in)**
- If not within wear limit, replace.

REPAIR FOR COMPONENT PARTS

Low & Reverse Brake (Cont'd)

NDAT0158

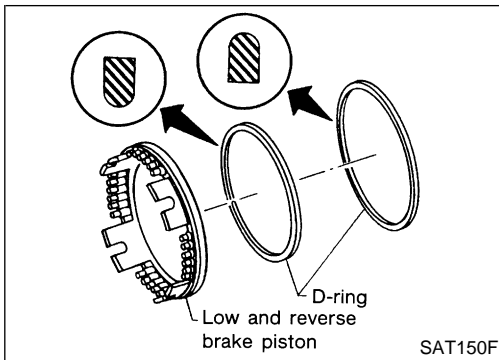

ASSEMBLY

1. Install D-rings on piston.
 - Apply ATF to both parts.

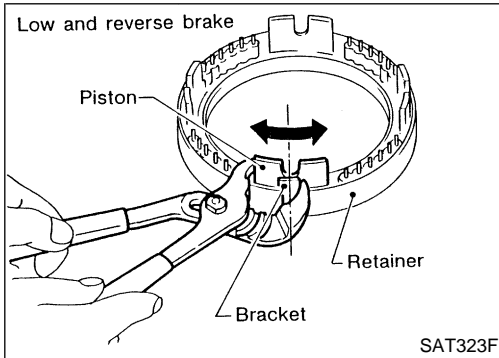

2. Set and align piston with retainer.
 - This operation is required in order to engage the protrusions of piston to return springs correctly. Further procedures are given in "Assembly (2), AT-355".

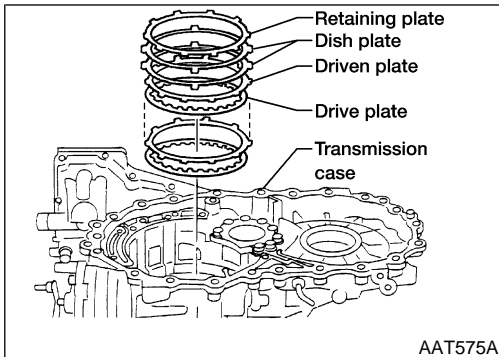

3. Install driven plates, drive plates, retaining plate and dish plate on transmission case.
 - Take care with order of plates and direction of dish plate.

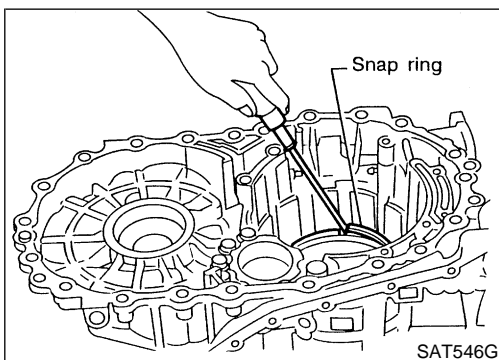

4. Install snap ring.

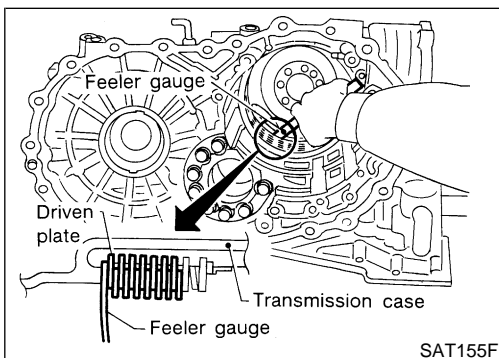

5. Measure clearance between driven plate and transmission case. If not within allowable limit, select proper retaining plate. (front side)

Specified clearance:

Standard 1.7 - 2.1 mm (0.067 - 0.083 in)

Allowable limit 3.3 mm (0.130 in)

Retaining plate:

Refer to "LOW & REVERSE BRAKE", AT-373.

GI

MA

EM

LC

EC

FE

AT

AX

SU

BR

ST

RS

BT

HA

SC

EL

IDX

REPAIR FOR COMPONENT PARTS

Rear Internal Gear, Forward Clutch Hub and Overrun Clutch Hub

Rear Internal Gear, Forward Clutch Hub and Overrun Clutch Hub COMPONENTS

NDAT0159

SEC. 315

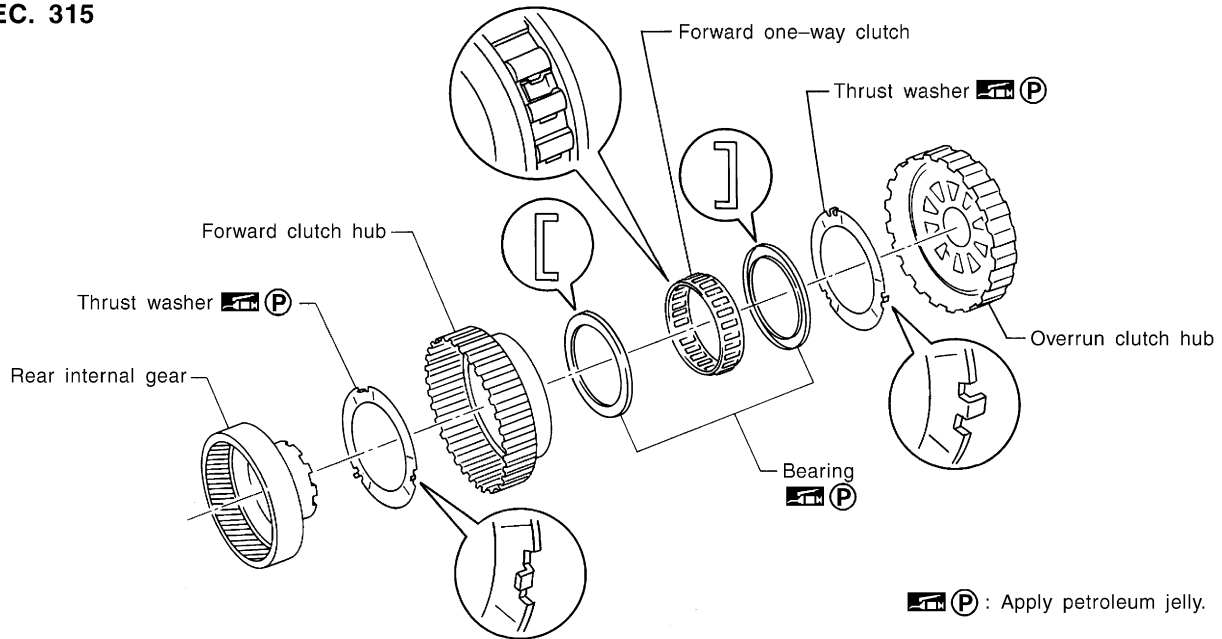

SAT975H

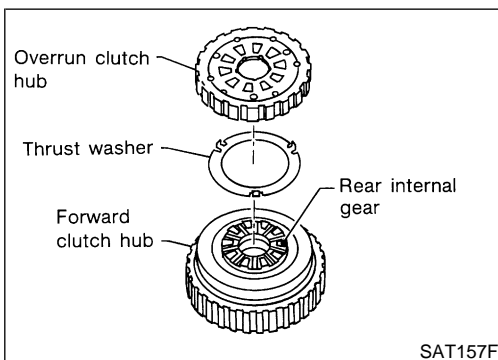

SAT157F

DISASSEMBLY

NDAT0160

1. Remove overrun clutch hub and thrust washer from forward clutch hub.

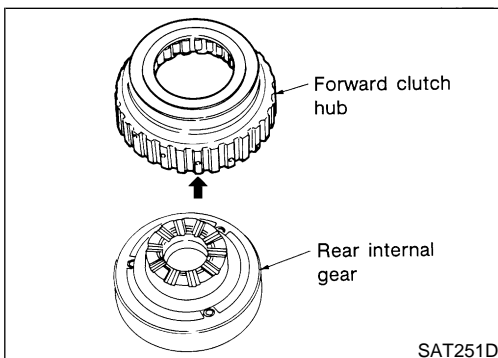

SAT251D

2. Remove forward clutch hub from rear internal gear.

REPAIR FOR COMPONENT PARTS

Rear Internal Gear, Forward Clutch Hub and Overrun Clutch Hub (Cont'd)

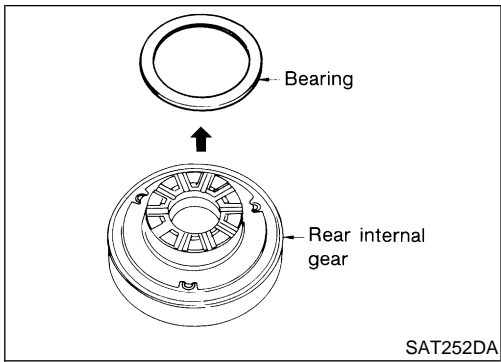

3. Remove bearing from rear internal gear.

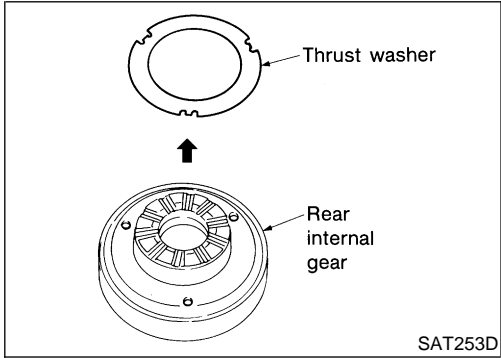

4. Remove thrust washer from rear internal gear.

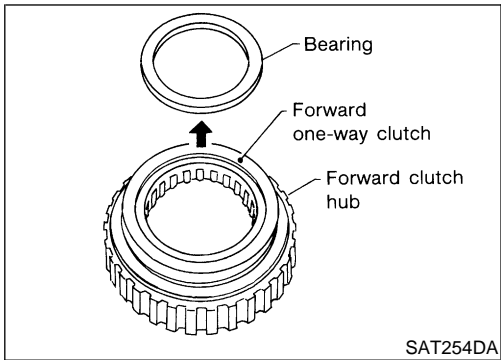

5. Remove bearing from forward one-way clutch.

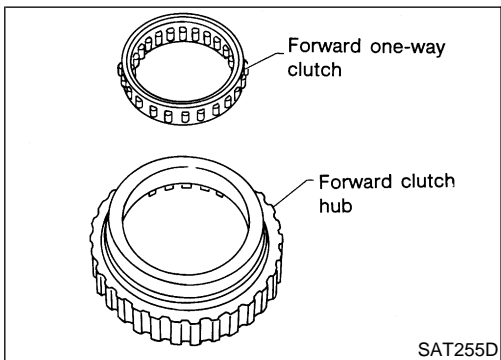

6. Remove forward one-way clutch from forward clutch hub.

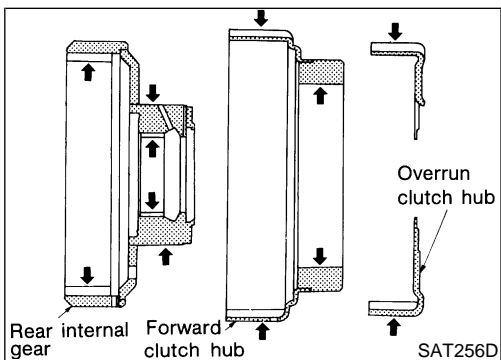

INSPECTION

Rear Internal Gear, Forward Clutch Hub and Overrun Clutch Hub

- Check rubbing surfaces for wear or damage.

NDAT0161

NDAT0161S01

GI

MA

EM

LC

EC

FE

AT

AX

SU

BR

ST

RS

BT

HA

SC

EL

IDX

REPAIR FOR COMPONENT PARTS

Rear Internal Gear, Forward Clutch Hub and Overrun Clutch Hub (Cont'd)

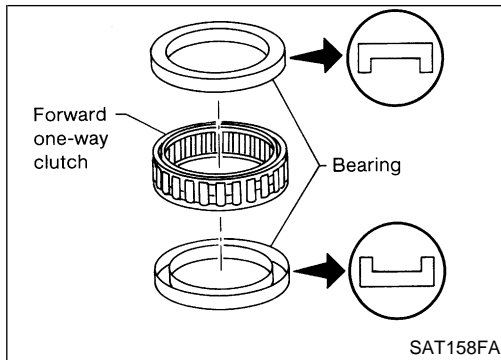

Bearings and Forward One-way Clutch

NDAT0161S02

- Check bearings for deformation and damage.
- Check forward one-way clutch for wear and damage.

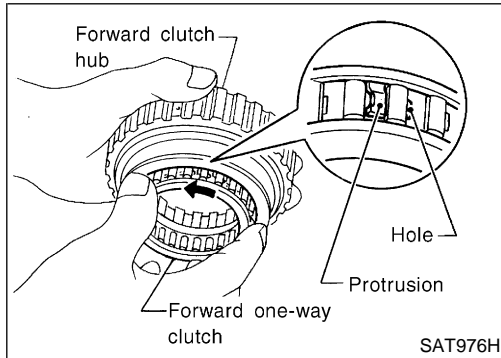

ASSEMBLY

NDAT0162

1. Install forward one-way clutch on forward clutch.
 - **Take care with the direction of forward one-way clutch.**

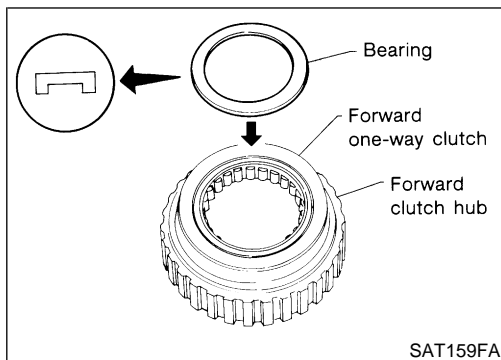

2. Install bearing on forward one-way clutch.
 - **Apply petroleum jelly to bearing.**

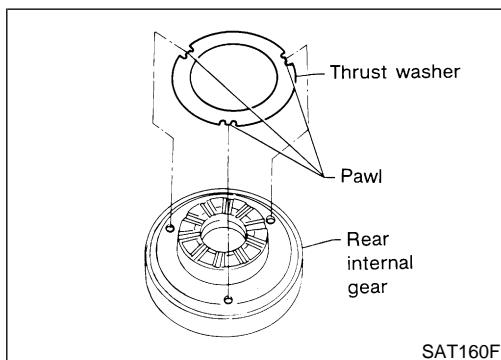

3. Install thrust washer on rear internal gear.
 - **Apply petroleum jelly to thrust washer.**
 - **Align hooks of thrust washer with holes of rear internal gear.**

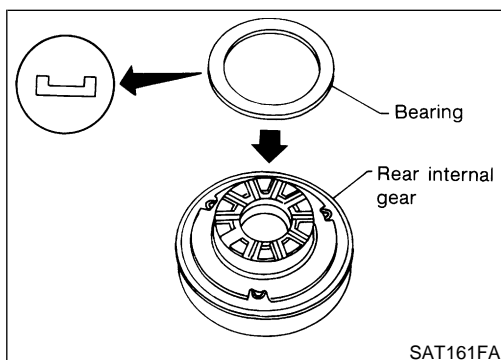

4. Install bearing on rear internal gear.
 - **Apply petroleum jelly to bearing.**

REPAIR FOR COMPONENT PARTS

Rear Internal Gear, Forward Clutch Hub and Overrun Clutch Hub (Cont'd)

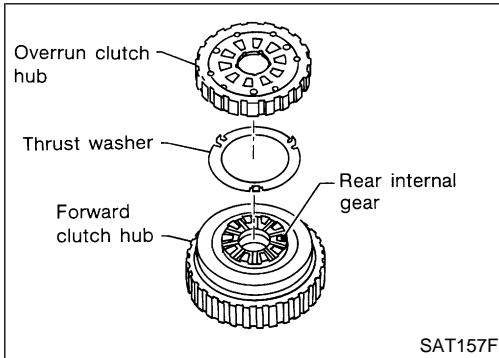
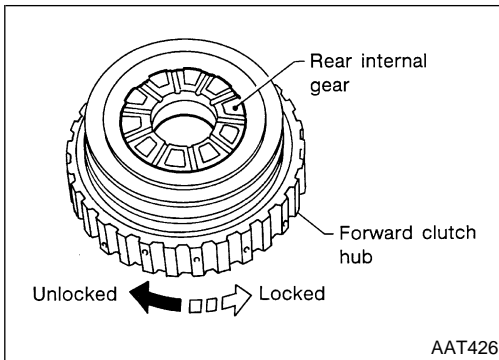

5. Install forward clutch hub on rear internal gear.
 - **Check operation of forward one-way clutch. Hold rear internal gear and turn forward clutch hub. Check forward clutch hub for correct locking and unlocking directions.**
 - **If not as shown in illustration, check installation direction of forward one-way clutch.**

6. Install thrust washer and overrun clutch hub.
 - **Apply petroleum jelly to thrust washer.**
 - **Align hooks of thrust washer with holes of overrun clutch hub.**
 - **Align projections of rear internal gear with holes of overrun clutch hub.**

GI

MA

EM

LC

EC

FE

AT

AX

SU

BR

ST

RS

BT

HA

SC

EL

IDX

REPAIR FOR COMPONENT PARTS

Output Shaft, Idler Gear, Reduction Pinion Gear and Bearing Retainer

Output Shaft, Idler Gear, Reduction Pinion Gear and Bearing Retainer COMPONENTS

NDAT0163

SEC. 314

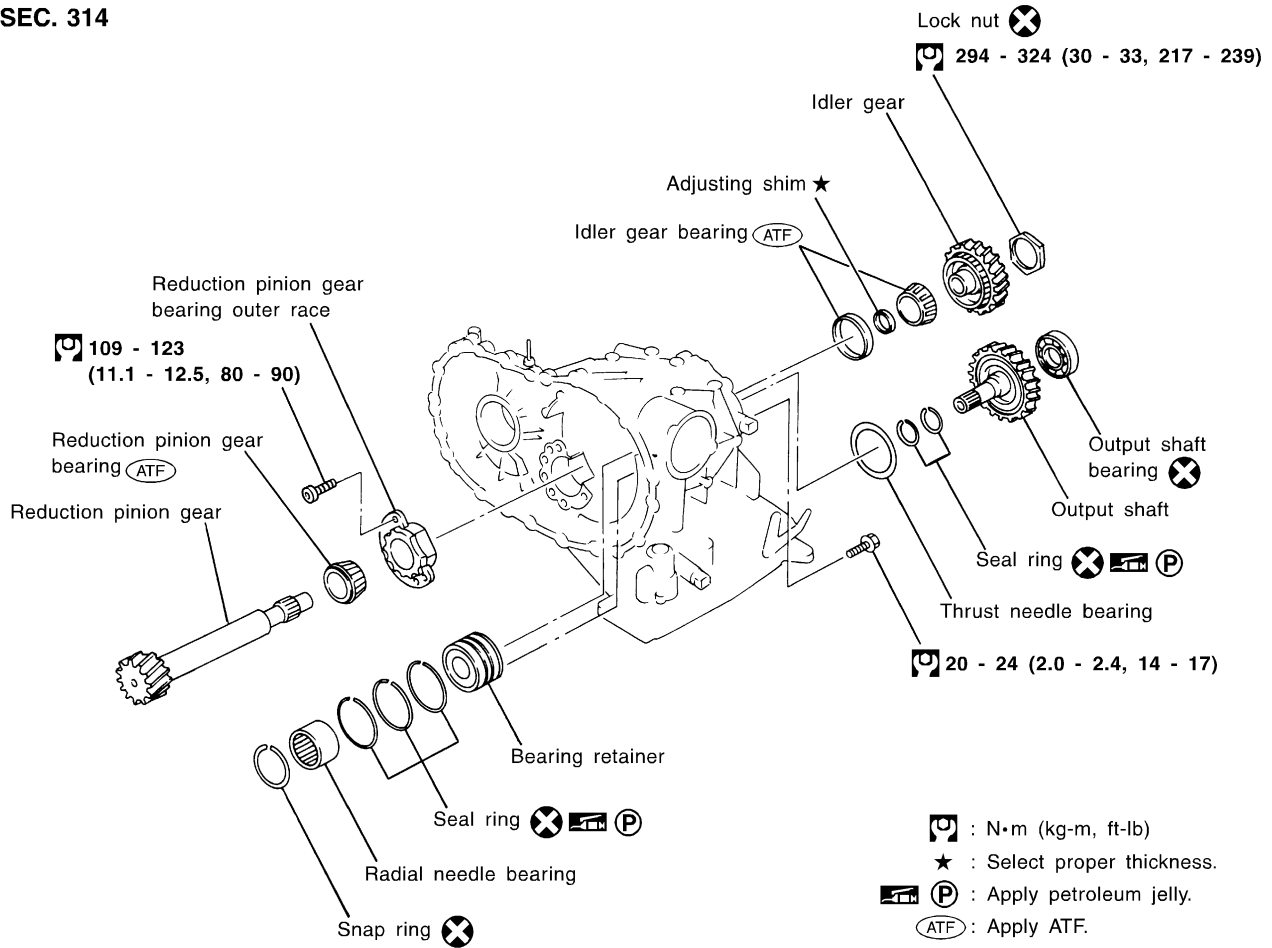

SAT291K

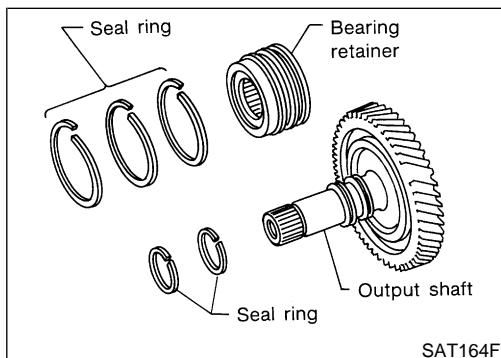

DISASSEMBLY

NDAT0164

1. Remove seal rings from output shaft and bearing retainer.

REPAIR FOR COMPONENT PARTS

Output Shaft, Idler Gear, Reduction Pinion Gear and Bearing Retainer (Cont'd)

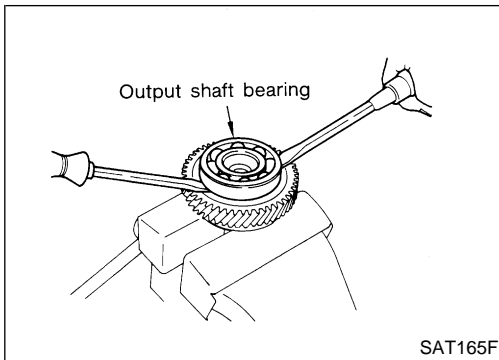

2. Remove output shaft bearing with screwdrivers.
 - Always replace bearing with a new one when removed.
 - Do not damage output shaft.

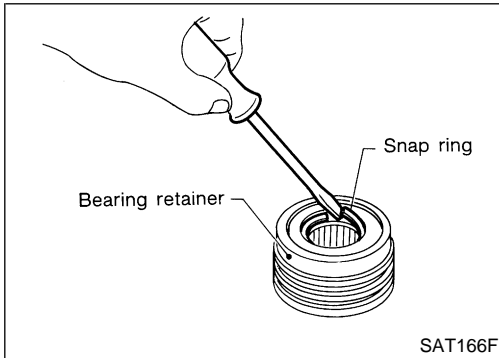

3. Remove snap ring from bearing retainer.

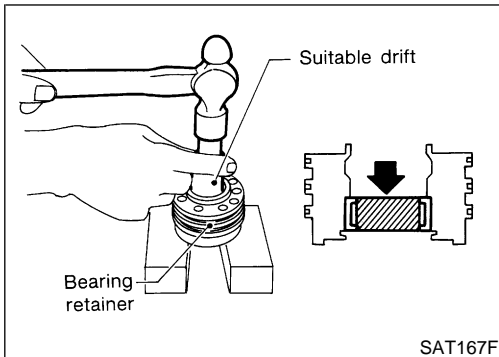

4. Remove needle bearing from bearing retainer.

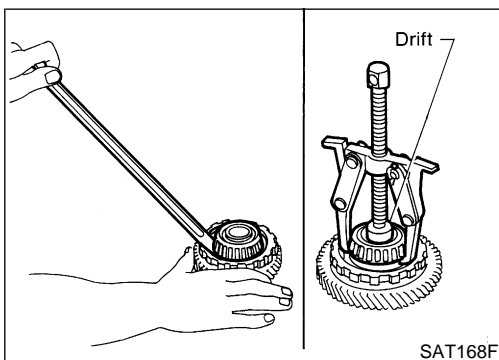

5. Remove idler gear bearing inner race from idler gear.

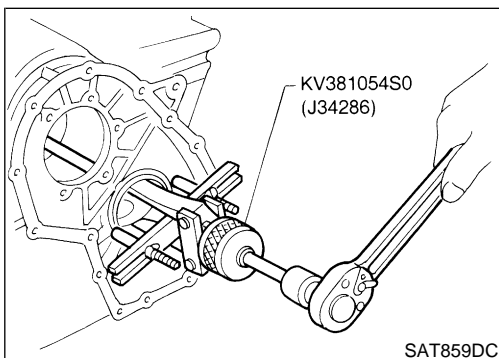

6. Remove idler gear bearing outer race from transmission case.

GI

MA

EM

LC

EC

FE

AT

AX

SU

BR

ST

RS

BT

HA

SC

EL

IDX

REPAIR FOR COMPONENT PARTS

Output Shaft, Idler Gear, Reduction Pinion Gear and Bearing Retainer (Cont'd)

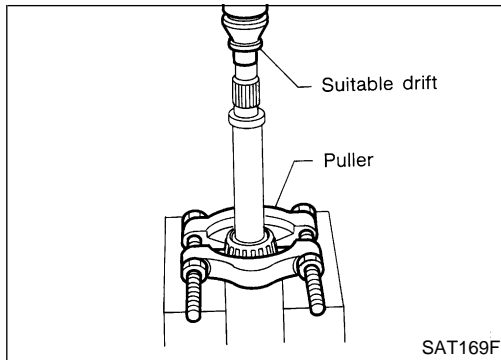

7. Press out reduction pinion gear bearing inner race from reduction pinion gear.

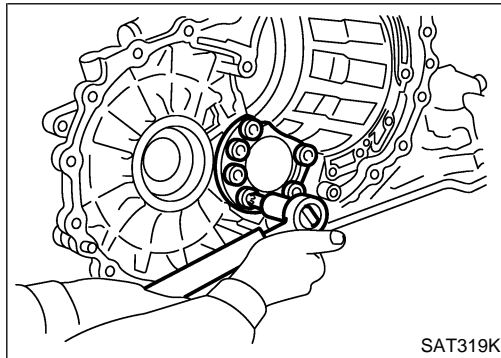

8. Remove reduction pinion gear bearing outer race from transmission case.

INSPECTION

Output Shaft, Idler Gear and Reduction Pinion Gear

NDAT0165
NDAT0165S01

- Check shafts for cracks, wear or bending.
- Check gears for wear, chips and cracks.

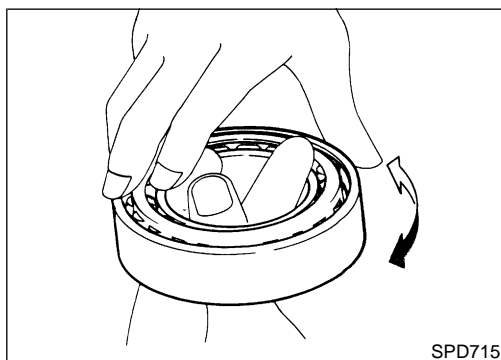

Bearing

NDAT0165S02

- Make sure bearings roll freely and are free from noise, cracks, pitting or wear.
- **When replacing taper roller bearing, replace outer and inner race as a set.**

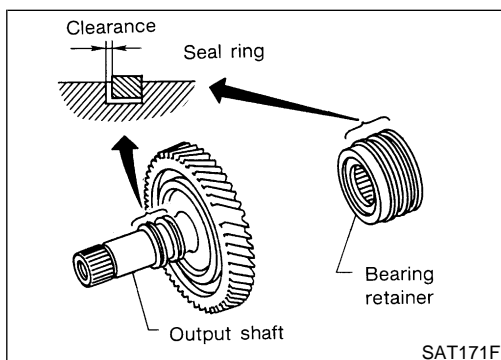

Seal Ring Clearance

NDAT0165S03

- Install new seal rings to output shaft.
- Measure clearance between seal ring and ring groove of output shaft.

Standard clearance:

0.10 - 0.25 mm (0.0039 - 0.0098 in)

Allowable limit:

0.25 mm (0.0098 in)

- If not within allowable limit, replace output shaft.
- Install new seal rings to bearing retainer.

REPAIR FOR COMPONENT PARTS

Output Shaft, Idler Gear, Reduction Pinion Gear and Bearing Retainer (Cont'd)

- Measure clearance between seal ring and ring groove of bearing retainer.

Standard clearance:

0.10 - 0.30 mm (0.0039 - 0.0118 in)

Allowable limit:

0.30 mm (0.0118 in)

- If not within allowable limit, replace bearing retainer.

GI

MA

EM

LC

NDAT0166

EC

FE

AT

AX

SU

BR

ST

RS

BT

HA

SC

EL

IDX

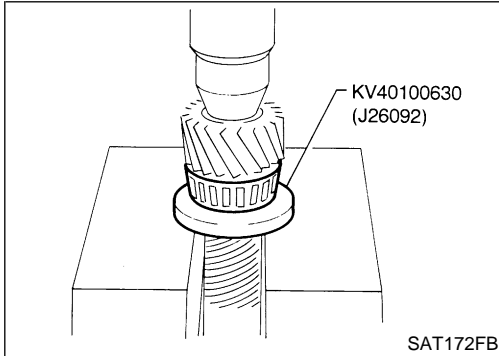

ASSEMBLY

1. Press reduction pinion gear bearing inner race on reduction pinion gear.

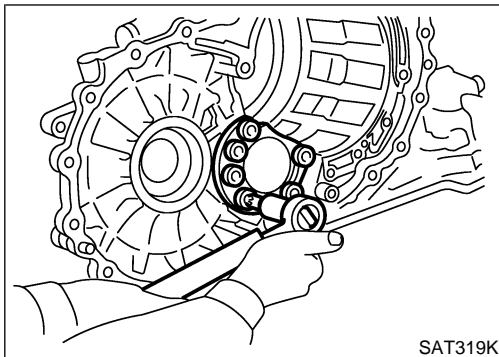

2. Install reduction pinion gear bearing outer race on transmission case.

⚙️ : 109 - 123 N-m (11.1 - 12.5 kg-m, 80 - 90 ft-lb)

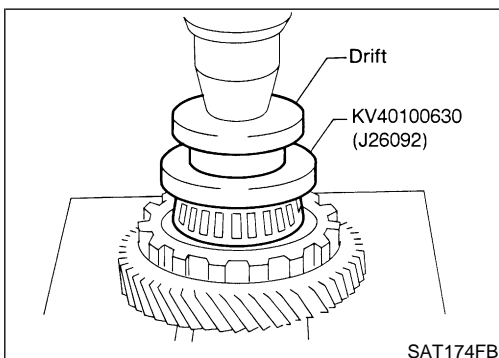

3. Press idler gear bearing inner race on idler gear.

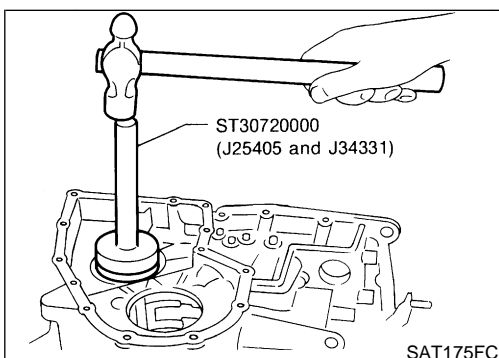

4. Install idler gear bearing outer race on transmission case.

REPAIR FOR COMPONENT PARTS

Output Shaft, Idler Gear, Reduction Pinion Gear and Bearing Retainer (Cont'd)

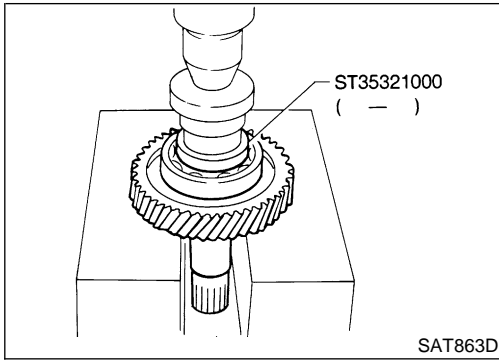

5. Press output shaft bearing on output shaft.

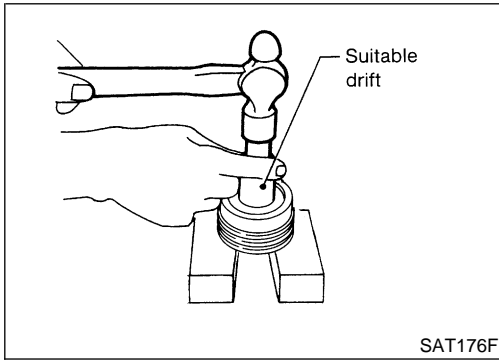

6. Press needle bearing on bearing retainer.

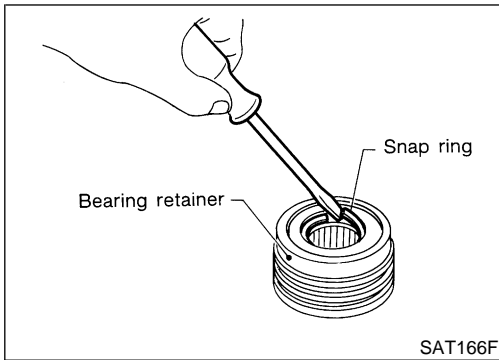

7. Install snap ring to bearing retainer.

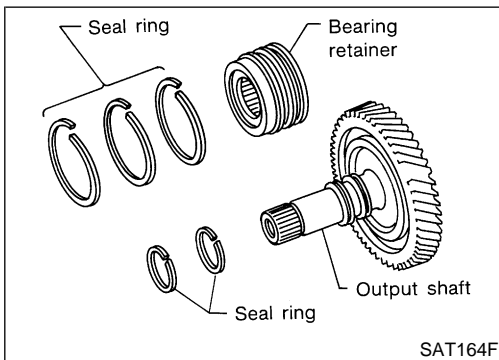

8. After packing ring grooves with petroleum jelly, carefully install new seal rings on output shaft and bearing retainer.

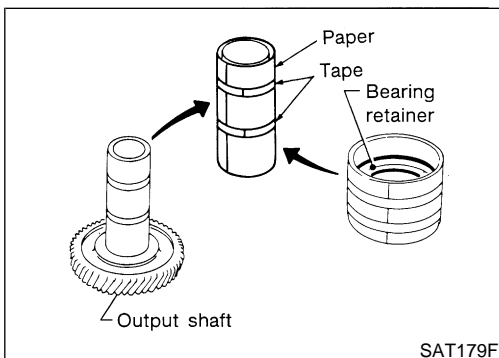

• Roll paper around seal rings to prevent seal rings from spreading.

Band Servo Piston Assembly COMPONENTS

NDAT0167

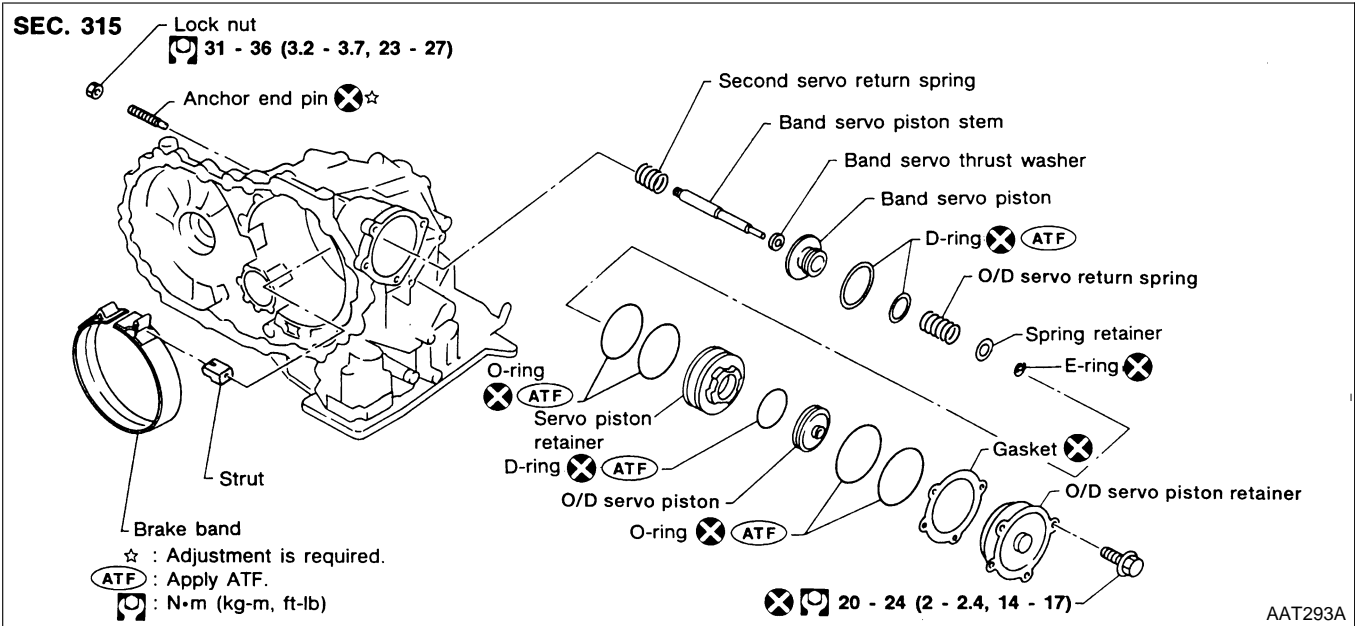

GI

MA

EM

LC

EC

FE

AT

AX

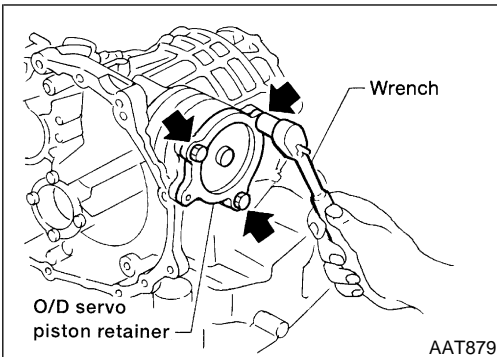

DISASSEMBLY

NDAT0168

1. Remove band servo piston fixing bolts.

SU

BR

ST

RS

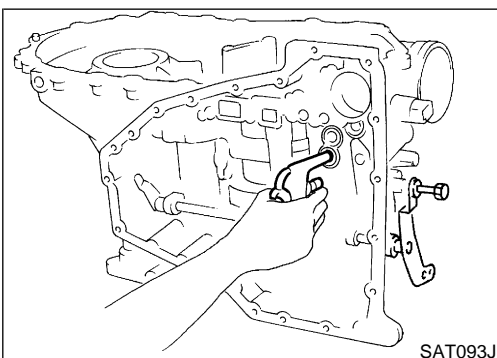

2. Apply compressed air to oil hole in transmission case to remove O/D servo piston retainer and band servo piston assembly.

BT

- Hold band servo piston assembly with a rag or nylon waste.

HA

SC

EL

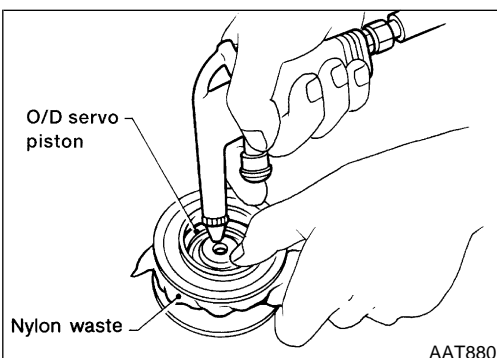

3. Apply compressed air to oil hole in O/D servo piston retainer to remove O/D servo piston from retainer.

IDX

- Hold O/D band servo piston while applying compressed air.

REPAIR FOR COMPONENT PARTS

Band Servo Piston Assembly (Cont'd)

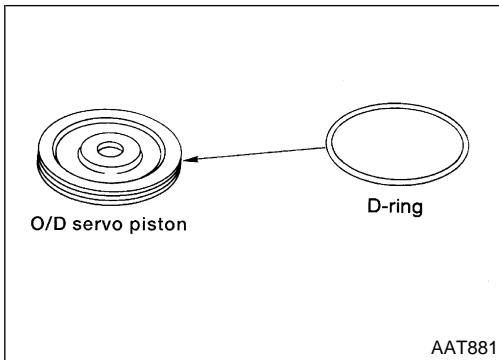

4. Remove D-ring from O/D servo piston.

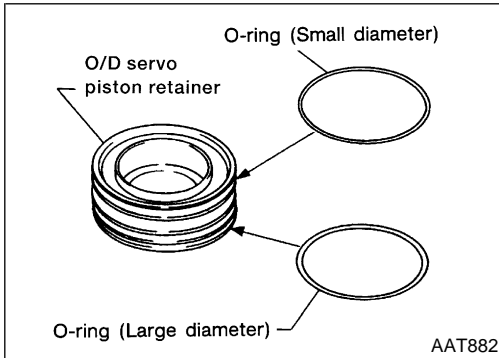

5. Remove O-rings from O/D servo piston retainer.

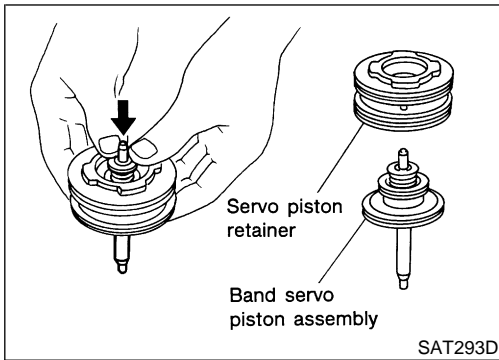

6. Remove band servo piston assembly from servo piston retainer by pushing it forward.

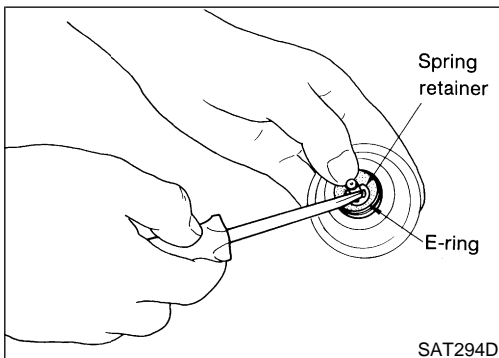

7. Place piston stem end on a wooden block. While pushing servo piston spring retainer down, remove E-ring.

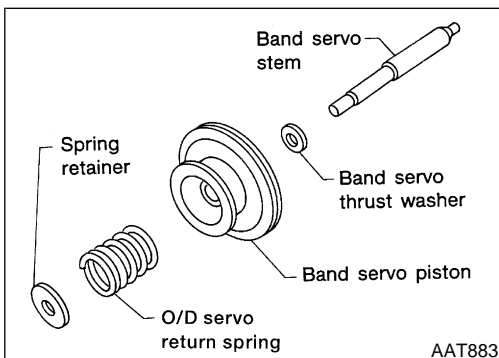

8. Remove O/D servo return spring, band servo thrust washer and band servo piston stem from band servo piston.

REPAIR FOR COMPONENT PARTS

Band Servo Piston Assembly (Cont'd)

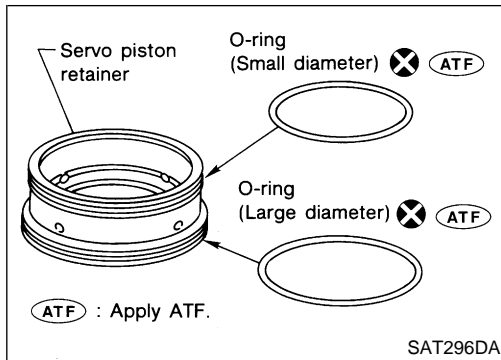

9. Remove O-rings from servo piston retainer.

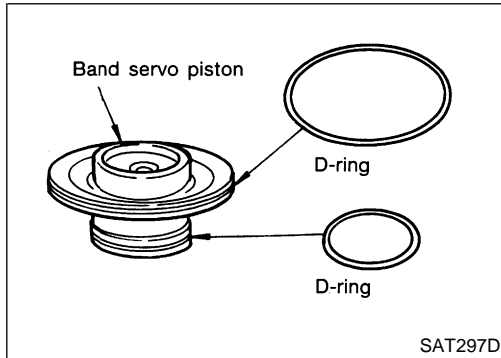

10. Remove D-rings from band servo piston.

INSPECTION

Pistons, Retainers and Piston Stem

- Check frictional surfaces for abnormal wear or damage.

NDAT0169

NDAT0169S01

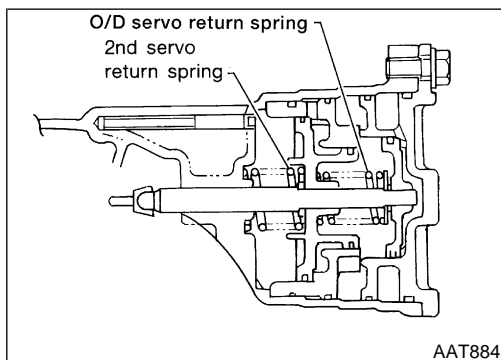

Return Springs

- Check for deformation or damage.
- Measure free length and outer diameter.

Inspection standard:

Refer to "RETURN SPRING", AT-376.

NDAT0169S02

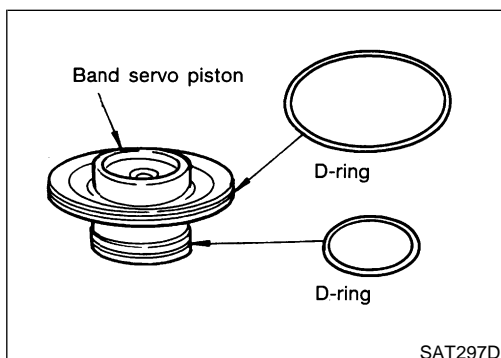

ASSEMBLY

1. Install D-rings to servo piston retainer.
- Apply ATF to D-rings.
 - Pay attention to position of each O-ring.

NDAT0170

GI

MA

EM

LC

EC

FE

AT

AX

SU

BR

ST

RS

BT

HA

SC

EL

IDX

REPAIR FOR COMPONENT PARTS

Band Servo Piston Assembly (Cont'd)

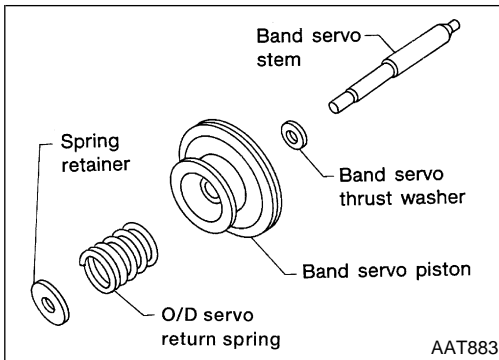

2. Install band servo piston stem, band servo thrust washer, O/D servo return spring and spring retainer to band servo piston.

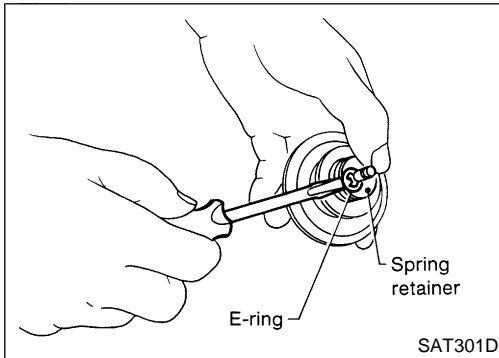

3. Place piston stem end on a wooden block. While pushing servo piston spring retainer down, install E-ring.

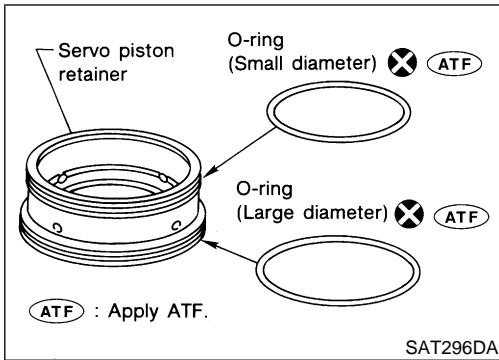

4. Install O-rings to servo piston retainer.
 - Apply ATF to O-rings.
 - Pay attention to position of each O-ring.

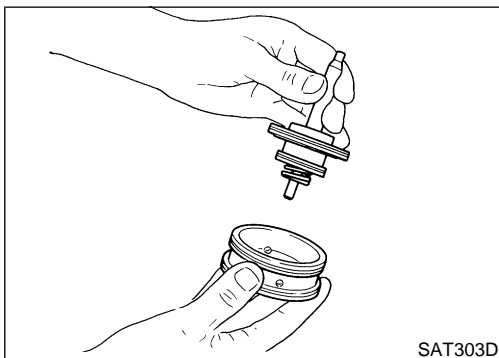

5. Install band servo piston assembly to servo piston retainer by pushing it inward.

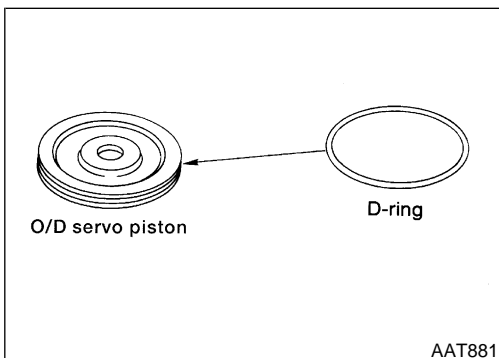

6. Install D-ring to O/D servo piston.
 - Apply ATF to D-ring.

REPAIR FOR COMPONENT PARTS

Band Servo Piston Assembly (Cont'd)

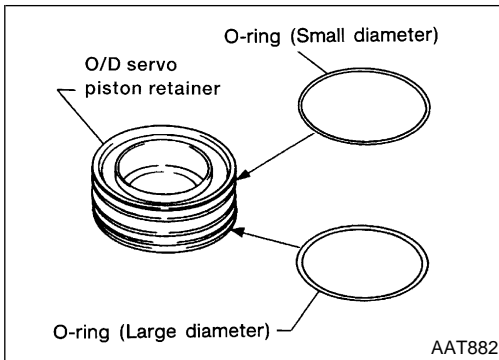

7. Install O-rings to O/D servo piston retainer.
 - **Apply ATF to O-rings.**
 - **Pay attention to position of each O-ring.**

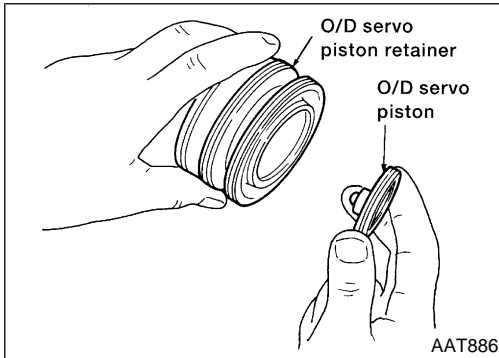

8. Install O/D servo piston to O/D servo piston retainer.

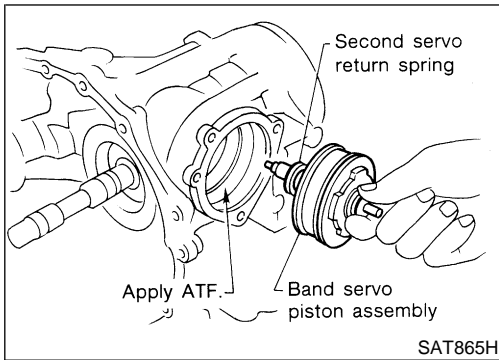

9. Install band servo piston assembly and 2nd servo return spring to transmission case.
 - **Apply ATF to O-ring of band servo piston and transmission case.**

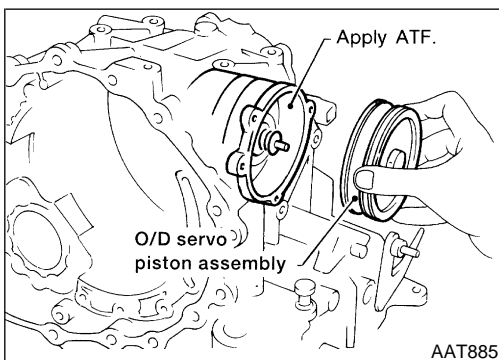

10. Install O/D servo piston assembly to transmission case.
 - **Apply ATF to O-ring of band servo piston and transmission case.**

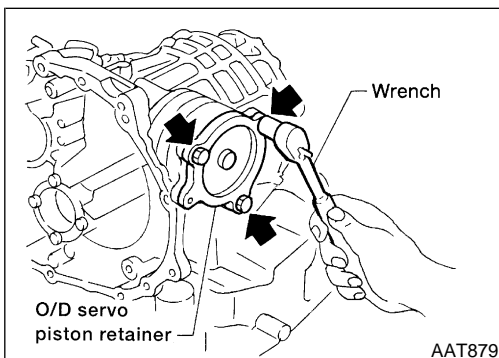

11. Install O/D servo piston retainer to transmission case.
⚙️ : 20 - 24 N-m (2 - 2.4 kg-m, 14 - 17 ft-lb)

GI

MA

EM

LC

EC

FE

AT

AX

SU

BR

ST

RS

BT

HA

SC

EL

IDX

REPAIR FOR COMPONENT PARTS

Final Drive

Final Drive COMPONENTS

NDAT0171

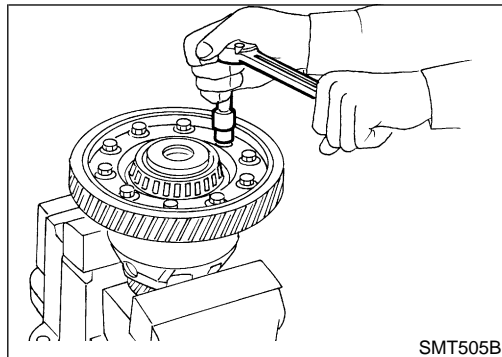
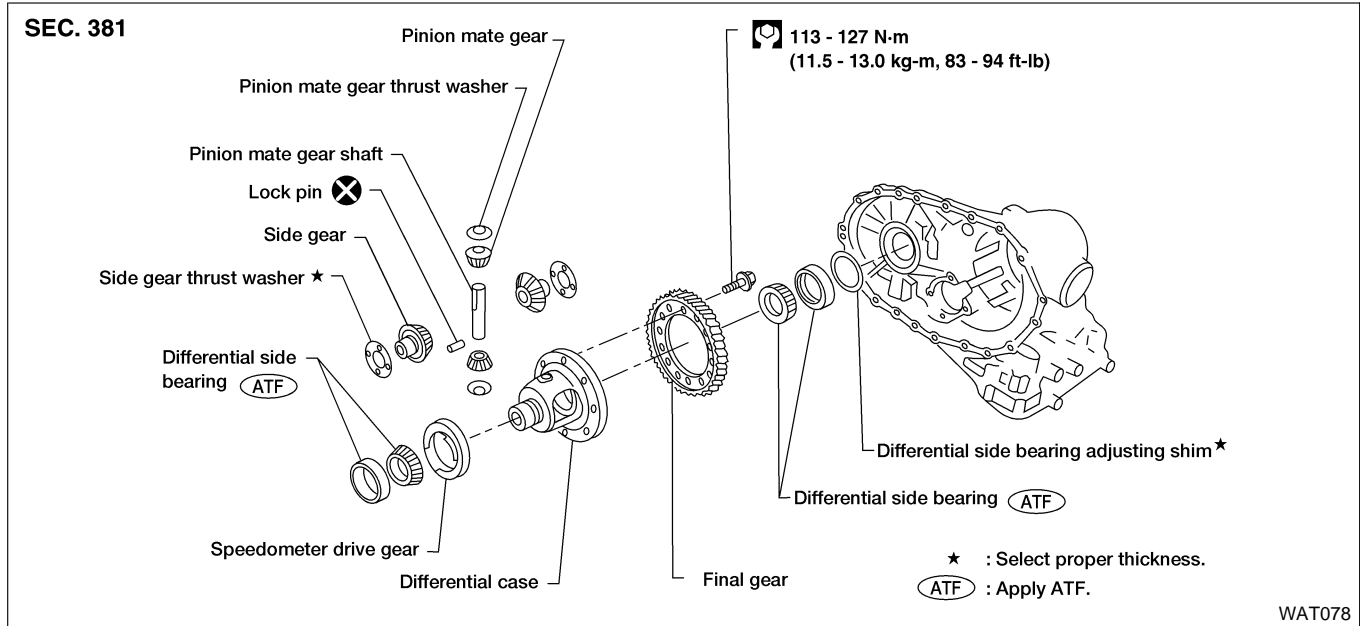

DISASSEMBLY

NDAT0172

1. Remove final gear.

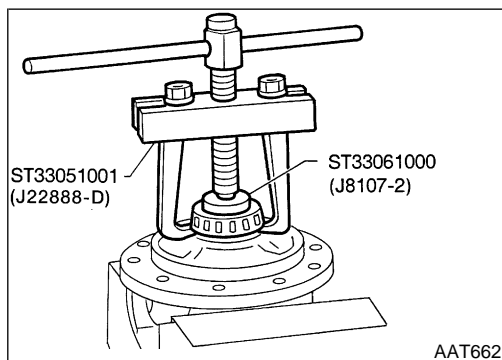

2. Press out differential side bearings.
 - Be careful not to mix up the right and left bearings.

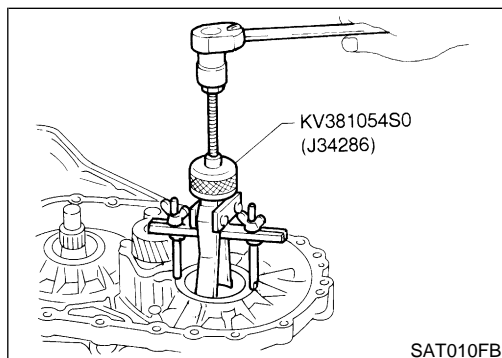

3. Remove differential side bearing outer race, and side bearing adjusting shim from transmission case.

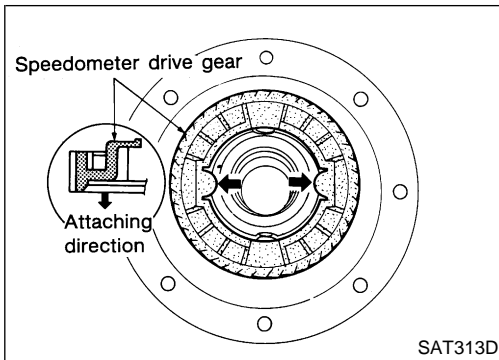

4. Remove speedometer drive gear.

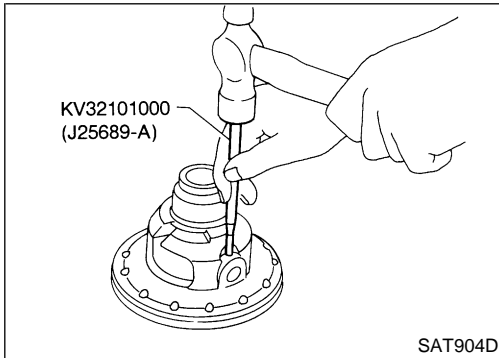

5. Drive out pinion mate gear shaft lock pin.

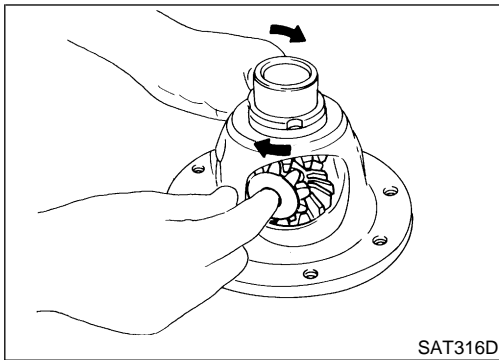

6. Draw out pinion mate gear shaft lock pin.

7. Remove pinion mate gears and side gears.

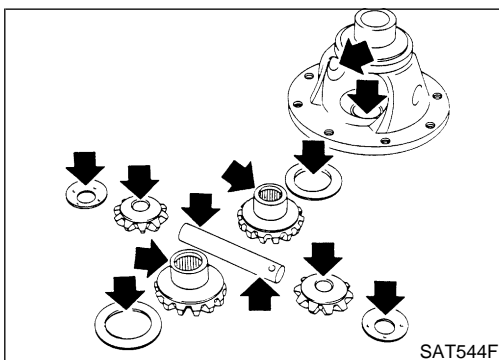

INSPECTION

Gear, Washer, Shaft and Case

- Check mating surfaces of differential case, side gears and pinion mate gears.
- Check washers for wear.

NDAT0173

NDAT0173S01

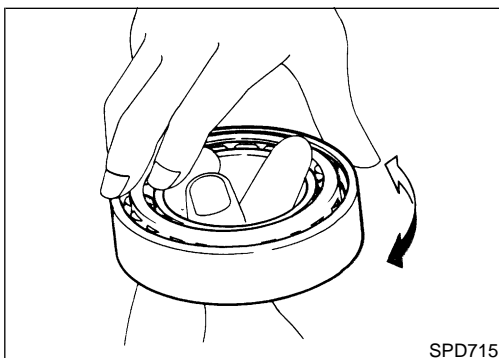

Bearings

- Make sure bearings roll freely and are free from noise, cracks, pitting or wear.
- **When replacing taper roller bearing, replace outer and inner race as a set.**

NDAT0173S02

GI

MA

EM

LC

EC

FE

AT

AX

SU

BR

ST

RS

BT

HA

SC

EL

IDX

REPAIR FOR COMPONENT PARTS

Final Drive (Cont'd)

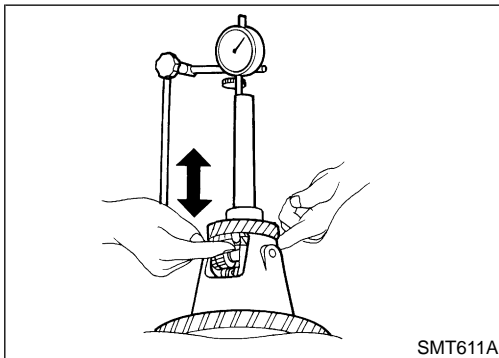
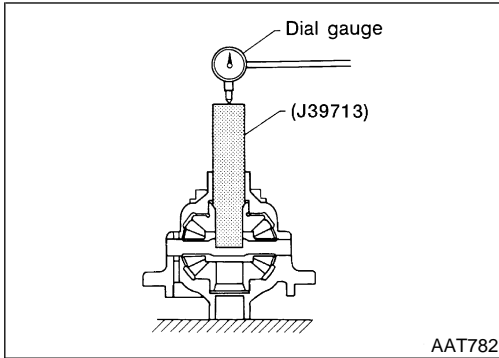
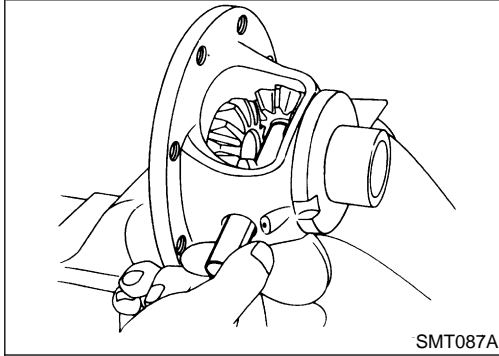
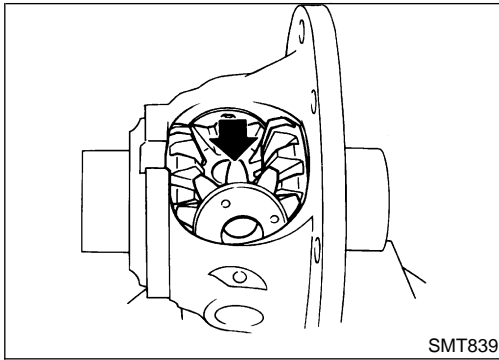

ASSEMBLY

1. Attach side gear thrust washers to side gears, then install pinion mate gear thrust washers and pinion mate gears in place. NDAT0174

2. Insert pinion mate gear shaft.
 - **When inserting, be careful not to damage pinion mate gear thrust washers.**

3. Measure clearance between side gear and differential case with washers following the procedure below:

- a. Set Tool and dial indicator on side gear.

- b. Move side gear up and down to measure dial indicator deflection. Always measure indicator deflection on both side gears.

Clearance between side gear and differential case with washer:

0.1 - 0.2 mm (0.004 - 0.008 in)

- c. If not within specification, adjust clearance by changing thickness of differential side gear thrust washers.

Differential side gear thrust washers:

Refer to "DIFFERENTIAL SIDE GEAR THRUST WASHERS", AT-373.

REPAIR FOR COMPONENT PARTS

Final Drive (Cont'd)

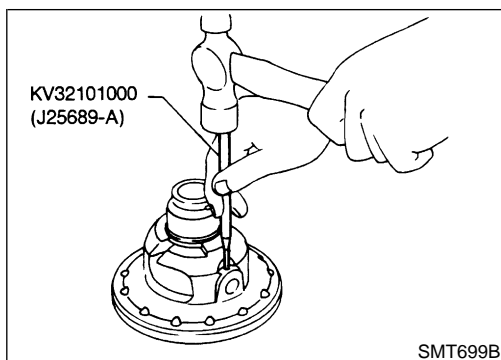

4. Install lock pin.
 - Make sure that lock pin is flush with case.

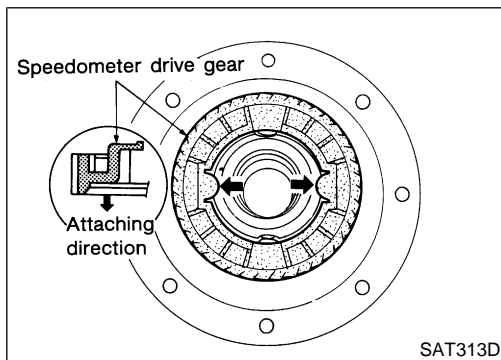

5. Install speedometer drive gear on differential case.
 - Align the projection of speedometer drive gear with the groove of differential case.

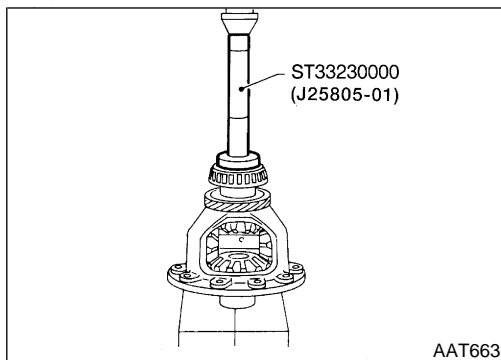

6. Press on differential side bearings.

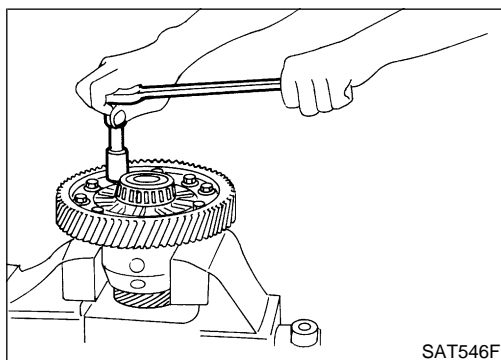

7. Install final gear and tighten fixing bolts in a crisscross pattern.
🔧 : 113 - 127 N·m (11.5 - 13.0 kg·m, 83 - 94 ft·lb)

GI

MA

EM

LC

EC

FE

AT

AX

SU

BR

ST

RS

BT

HA

SC

EL

IDX

ASSEMBLY

Assembly (1)

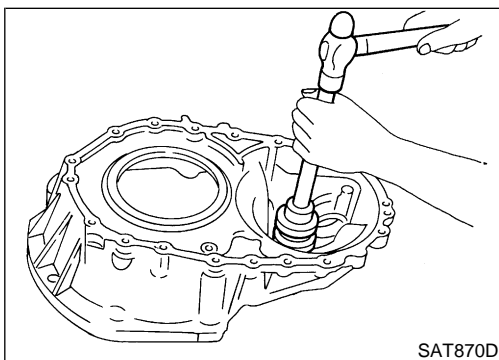
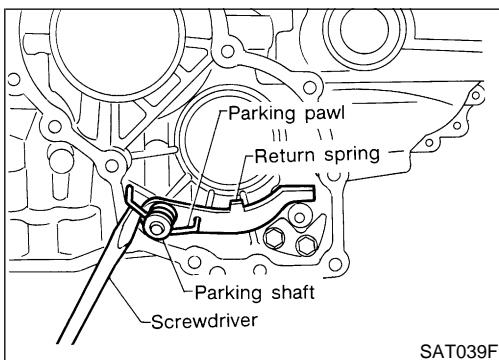
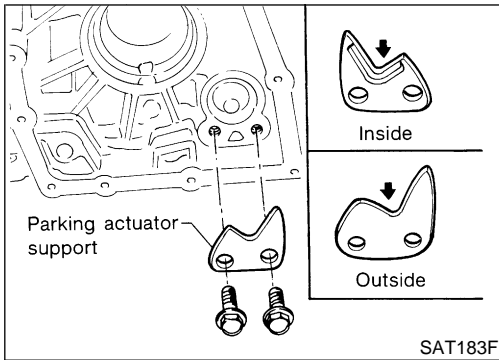
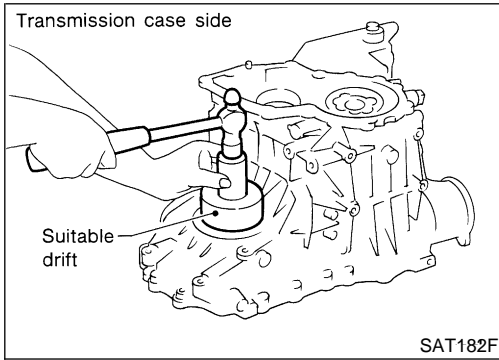
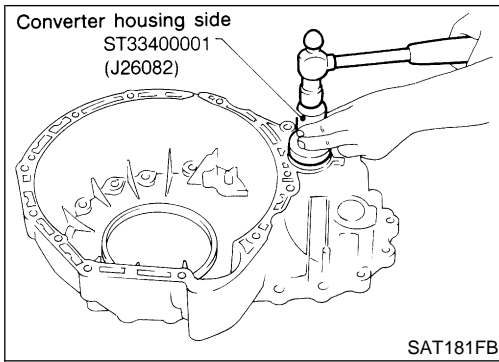

Assembly (1)

NDAT0175

1. Install differential side oil seals on transmission case and converter housing.

2. Install parking actuator support to transmission case.

- Pay attention to direction of parking actuator support.

3. Install parking pawl on transmission case and fix it with parking shaft.

4. Install return spring.

Adjustment (1)

NDAT0176

DIFFERENTIAL SIDE BEARING PRELOAD

NDAT0176S01

1. Install differential side bearing outer race without adjusting shim on transmission case.
2. Install differential side bearing outer race on converter housing.

ASSEMBLY

Adjustment (1) (Cont'd)

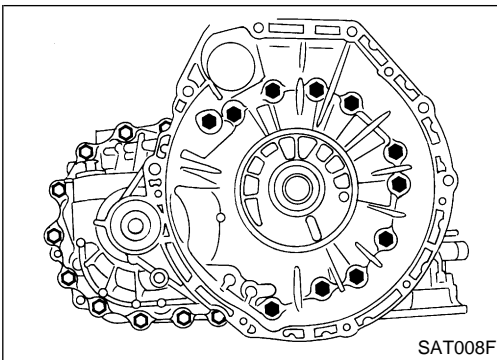

3. Place final drive assembly on transmission case.
4. Install transmission case on converter housing. Tighten transmission case fixing bolts to the specified torque. Refer to "Components", AT-276.

GI

MA

EM

LC

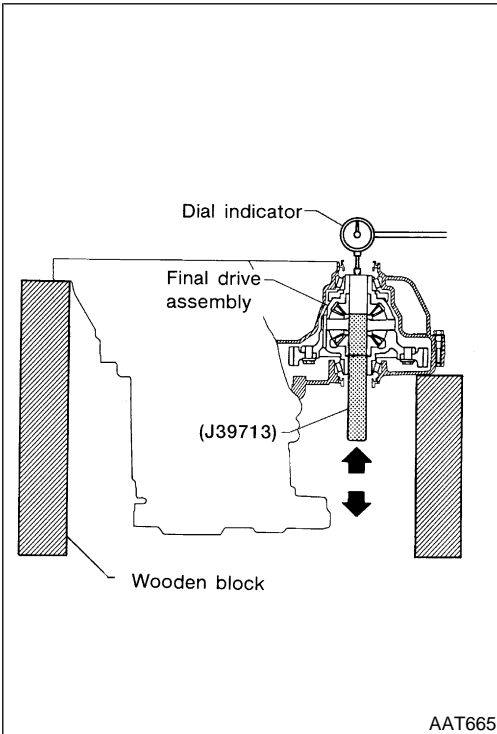

5. Attach dial indicator on differential case at converter housing side.
6. Insert Tool into differential side gear from transmission case side.
7. Move Tool up and down and measure dial indicator deflection.
8. Select proper thickness of differential side bearing adjusting shim(s).

EC

FE

Suitable shim thickness = Dial indicator deflection + Specified bearing preload

AT

Differential side bearing preload adjusting shim:

Refer to "DIFFERENTIAL SIDE BEARING PRELOAD ADJUSTING SHIMS", AT-374.

AX

Bearing preload:

0.05 - 0.09 mm (0.0020 - 0.0035 in)

SU

BR

ST

RS

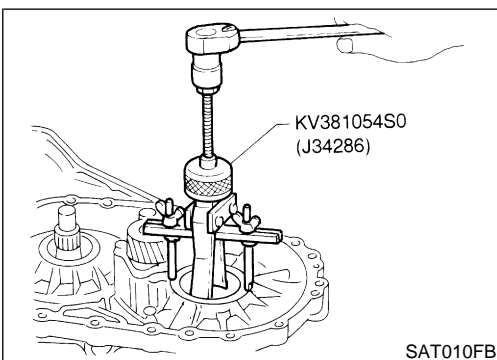

9. Remove converter housing from transmission case.
10. Remove final drive assembly from transmission case.
11. Remove differential side bearing outer race from transmission case.
12. Reinstall differential side bearing outer race and shim(s) selected from SDS table on transmission case.
13. Reinstall converter housing on transmission case and tighten transmission case fixing bolts to the specified torque. Refer to "Components", AT-276.

BT

HA

SC

EL

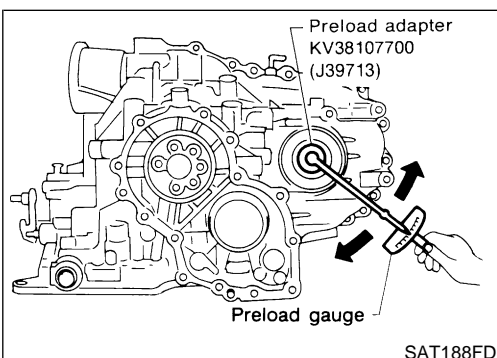

14. Insert Tool and measure turning torque of final drive assembly.
 - Turn final drive assembly in both directions several times to seat bearing rollers correctly.

IDX

Turning torque of final drive assembly (New bearing):

0.78 - 1.37 N·m (8.0 - 14.0 kg·cm, 6.9 - 12.2 in·lb)

- When old bearing is used again, turning torque will be slightly less than the above.
- Make sure torque is close to the specified range.

ASSEMBLY

Adjustment (1) (Cont'd)

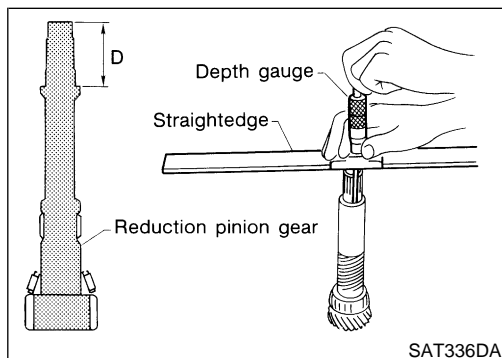
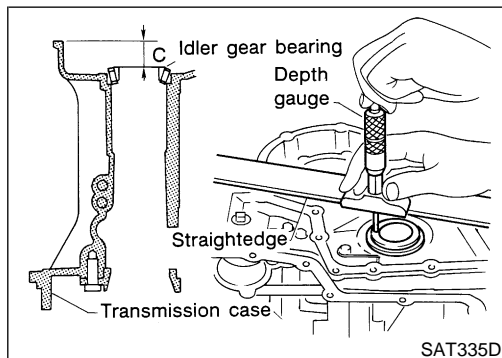
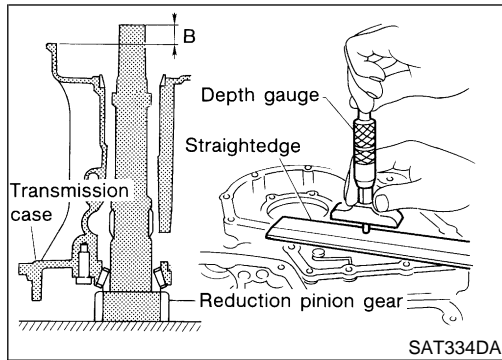
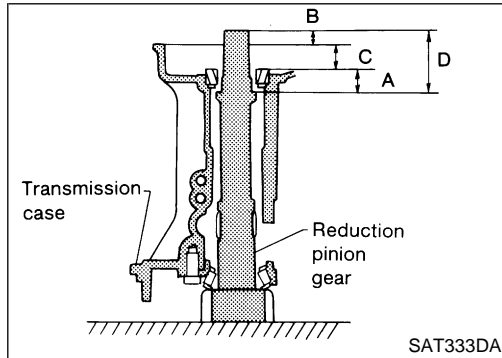
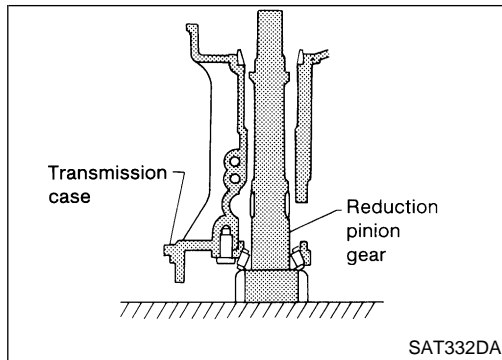

REDUCTION PINION GEAR BEARING PRELOAD

NDAT0176S02

1. Remove transmission case and final drive assembly from converter housing.
2. Select proper thickness of reduction pinion gear bearing adjusting shim using the following procedures.

- a. Place reduction pinion gear on transmission case as shown.

- b. Place idler gear bearing on transmission case.

- c. Measure dimensions "B" "C" and "D" and calculate dimension "A".

$$A = D - (B + C)$$

"A": Distance between the surface of idler gear bearing inner race and the adjusting shim mating surface of reduction pinion gear.

- Measure dimension "B" between the end of reduction pinion gear and the surface of transmission case.
- **Measure dimension "B" in at least two places.**

- Measure dimension "C" between the surface of idler gear bearing inner race and the surface of transmission case.
- **Measure dimension "C" in at least two places.**

- Measure dimension "D" between the end of reduction pinion gear and the adjusting shim mating surface of reduction pinion gear.
- **Measure dimension "D" in at least two places.**

- Calculate dimension "A".

$$A = D - (B + C)$$

ASSEMBLY

Adjustment (1) (Cont'd)

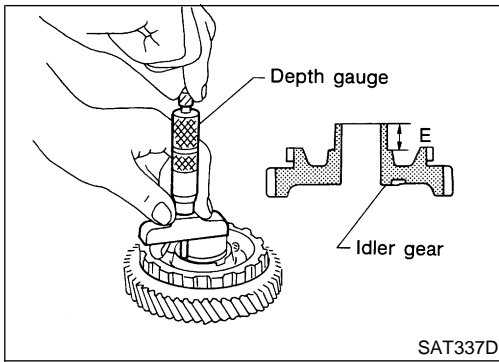

- d. Measure dimension "E" between the end of idler gear and the idler gear bearing inner race mating surface of idler gear.
 - **Measure dimension "E" in at least two places.**

GI

MA

EM

LC

- e. Select proper thickness of reduction pinion gear bearing adjusting shim.

Proper shim thickness = A - E - 0.05 mm (0.0020 in)*
 (* ... Bearing preload)

Reduction pinion gear bearing adjusting shim:

Refer to "REDUCTION PINION GEAR BEARING ADJUSTING SHIMS", AT-375.

EC

FE

AT

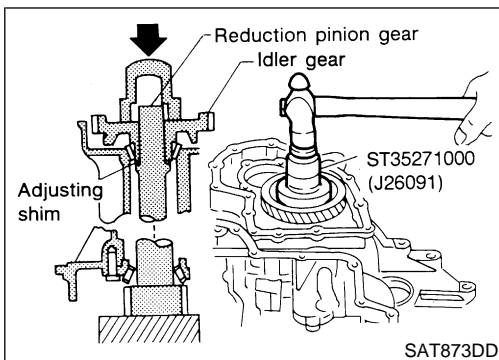

3. Install reduction gear and reduction gear bearing adjusting shim selected in step 2-e on transmission case.
4. Press idler gear bearing inner race on idler gear.
5. Press idler gear on reduction gear.
 - **Press idler gear until idler gear fully contacts adjusting shim.**

AX

SU

BR

ST

RS

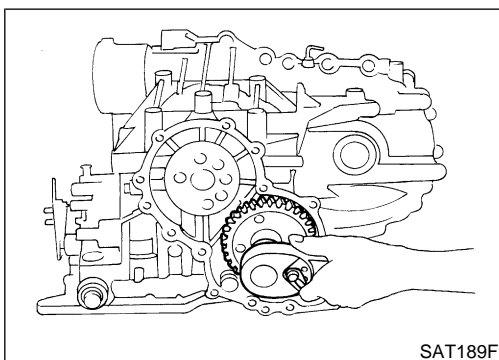

6. Tighten idler gear lock nut to the specified torque. Refer to "COMPONENTS", AT-336.
 - **Lock idler gear with parking pawl when tightening lock nut.**

BT

HA

SC

EL

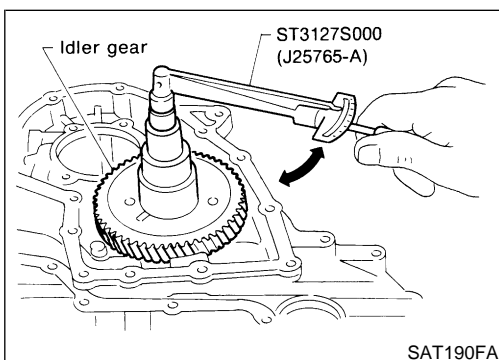

7. Measure turning torque of reduction pinion gear.
 - **When measuring turning torque, turn reduction pinion gear in both directions several times to seat bearing rollers correctly.**

Turning torque of reduction pinion gear:
0.05 - 0.39 N·m (0.5 - 4.0 kg·cm, 0.43 - 3.47 in·lb)
 - **If turning torque is out of specification, decrease or increase thickness of reduction pinion gear bearing adjusting shim.**

IDX

ASSEMBLY

Adjustment (1) (Cont'd)

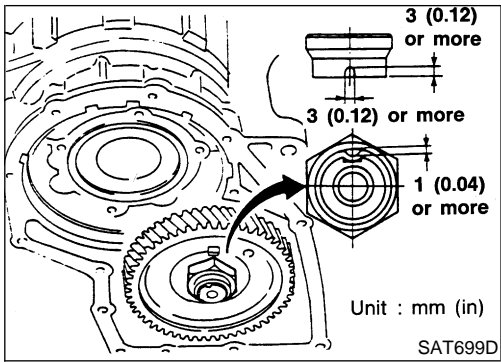

8. After properly adjusting turning torque, clinch idler gear lock nut as shown.

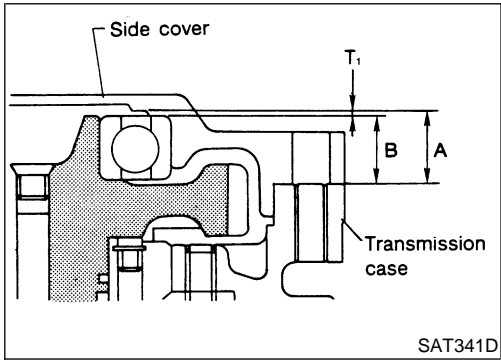

OUTPUT SHAFT END PLAY

INDAT0176S03

- Measure clearance between side cover and the end of the output shaft bearing.
- Select proper thickness of adjusting shim so that clearance is within specifications.

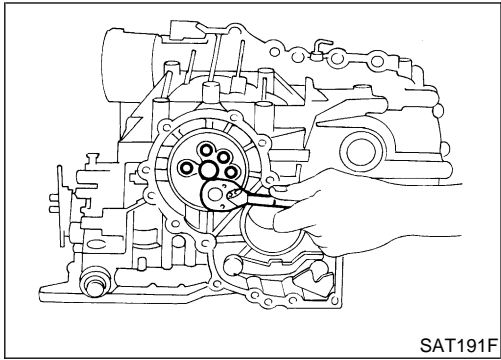

1. Install bearing retainer for output shaft.

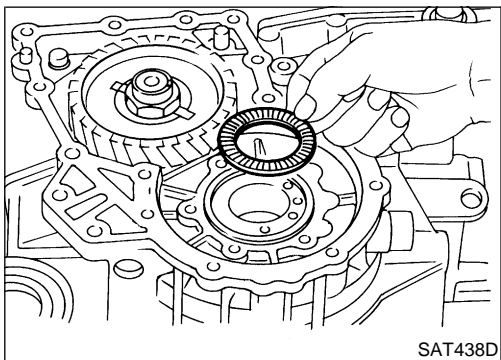

2. Install output shaft thrust needle bearing on bearing retainer.

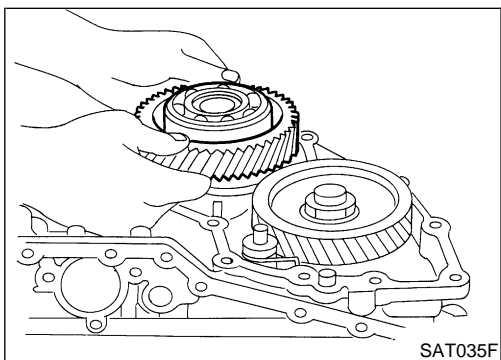

3. Install output shaft on transmission case.

ASSEMBLY

Adjustment (1) (Cont'd)

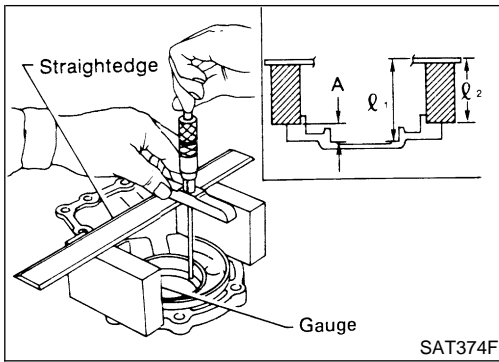

4. Measure dimensions “ l_1 ” and “ l_2 ” at side cover and then calculate dimension “A”.

- Measure dimension “ l_1 ” and “ l_2 ” in at least two places.
“A”: Distance between transmission case fitting surface and adjusting shim mating surface.

$$A = l_1 - l_2$$

l_2 : Height of gauge

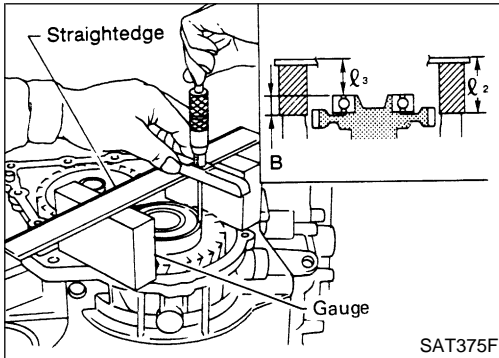

5. Measure dimensions “ l_2 ” and “ l_3 ” and then calculate dimension “B”.

- Measure “ l_2 ” and “ l_3 ” in at least two places.
“B”: Distance between the end of output shaft bearing outer race and the side cover fitting surface of transmission case.

$$B = l_2 - l_3$$

l_2 : Height of gauge

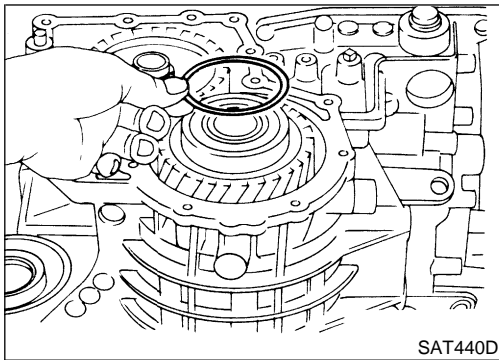

6. Select proper thickness of adjusting shim so that output shaft end play (clearance between side cover and output shaft bearing) is within specifications.

Output shaft end play (A – B):

0 - 0.15 mm (0 - 0.0059 in)

Output shaft end play adjusting shims:

Refer to “OUTPUT SHAFT ADJUSTING SHIMS”, AT-377.

7. Install adjusting shim on output shaft bearing.

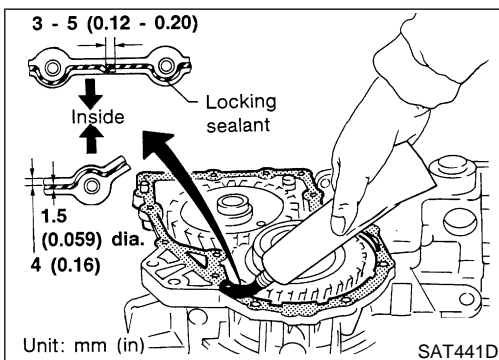

Assembly (2)

NDAT0177

1. Apply locking sealant (Loctite #518) to transmission case as shown in illustration.

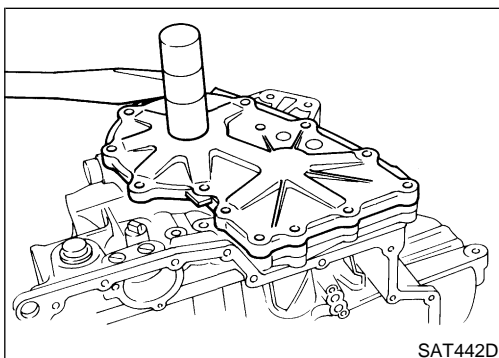

2. Set side cover on transmission case.

- Apply locking sealant to the mating surface of transmission case.

ASSEMBLY

Assembly (2) (Cont'd)

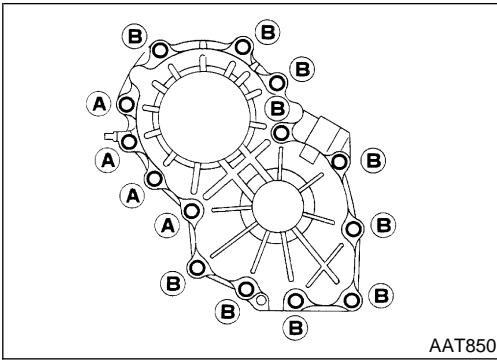

3. Tighten side cover fixing bolts to specified torque.
● **⚙️ : 3.0 - 3.4 N·m (0.31 - 0.35 kg·m, 26.9 - 30.4 in·lb)**
 - Do not mix bolts A and B.
 - Always replace bolts A, as they are self-sealing bolts.

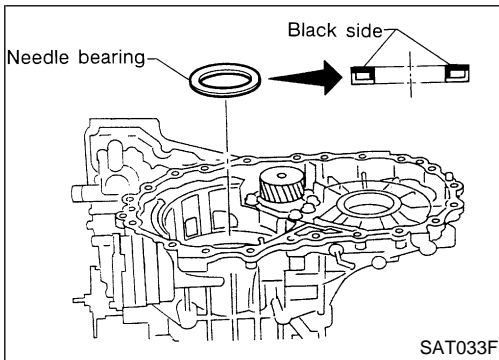

4. Remove paper rolled around bearing retainer.
5. Install thrust washer on bearing retainer.
 - Apply petroleum jelly to thrust washer.

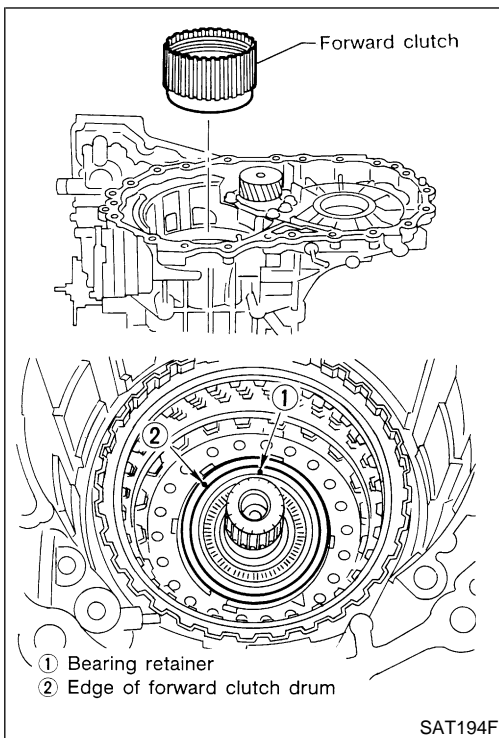

6. Install forward clutch assembly.
 - Align teeth of low & reverse brake drive plates before installing.
 - Make sure that bearing retainer seal rings are not spread.
 - If forward clutch assembly is correctly seated, points 1 and 2 are at almost same level.

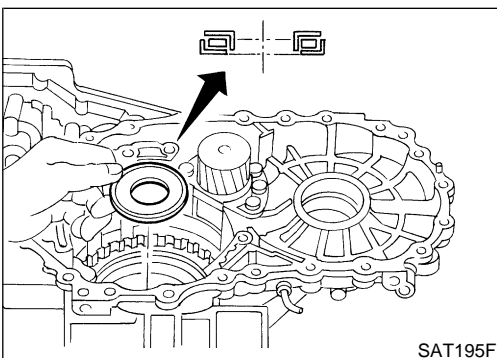

7. Install thrust needle bearing on bearing retainer.
 - Apply petroleum jelly to thrust needle bearing.
 - Pay attention to direction of thrust needle bearing.

ASSEMBLY

Assembly (2) (Cont'd)

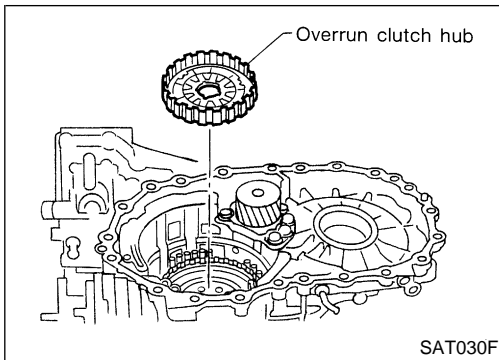

8. Install overrun clutch hub.
 - Apply petroleum jelly to thrust washers.
 - Align teeth of overrun clutch drive plates before installing.

GI

MA

EM

LC

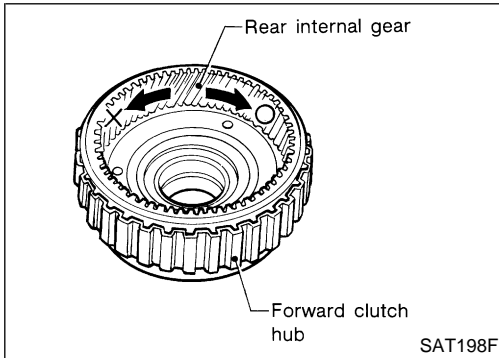

9. Hold forward clutch hub and turn rear internal gear. Check overrun clutch hub for correct directions of lock and unlock.
 - If not shown as illustrated, check installed direction of forward one-way clutch.

EC

FE

AT

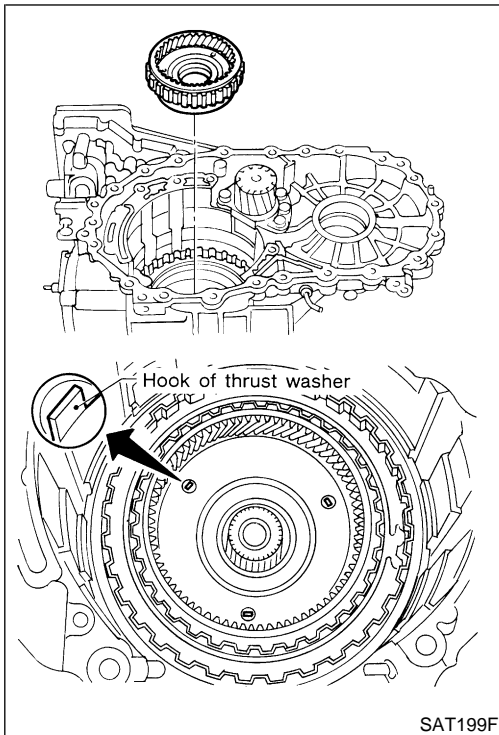

10. Install forward clutch hub and rear internal gear assembly.
 - Align teeth of forward clutch drive plates before installing.
 - Check that three hooks of thrust washer are correctly aligned after installing.

AX

SU

BR

ST

RS

BT

HA

SC

EL

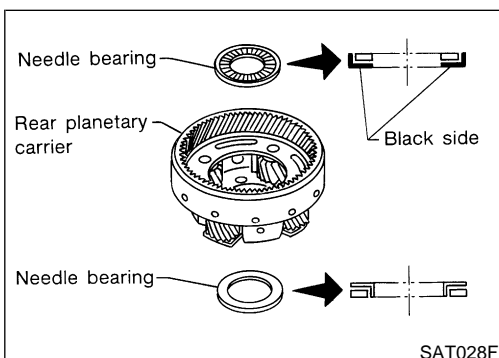

11. Install rear planetary carrier assembly and rear sun gear according to the following procedures.

IDX

- a. Install needle bearings on rear planetary carrier.
 - Apply petroleum jelly to needle bearings.
 - Pay attention to direction of needle bearings.

ASSEMBLY

Assembly (2) (Cont'd)

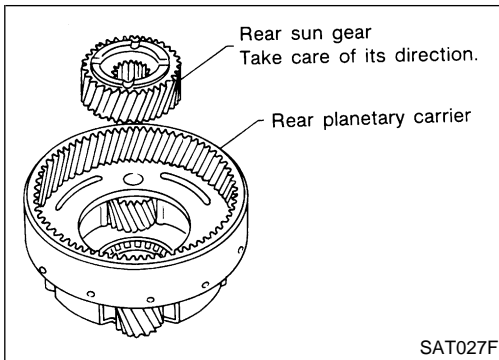

- b. Install rear sun gear on rear planetary carrier.
 - Pay attention to direction of rear sun gear.

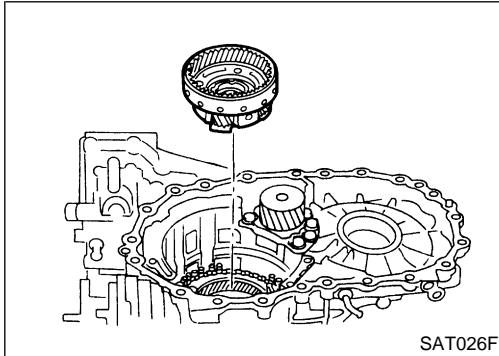

- c. Install rear planetary carrier on transmission case.

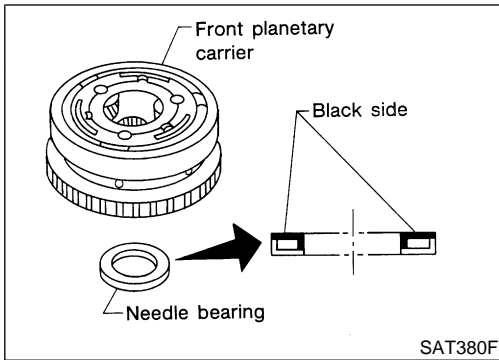

12. Install thrust needle bearing on front planetary carrier, then install them together on transmission case.
 - Apply petroleum jelly to thrust needle bearing.
 - Pay attention to direction of thrust needle bearing.

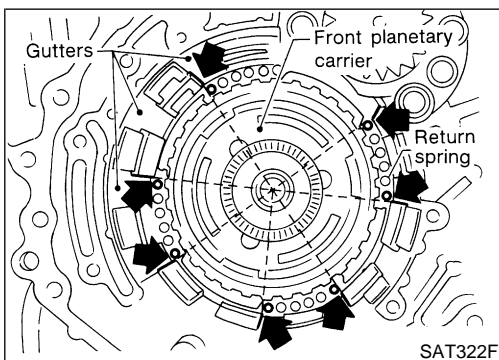

13. Install low and reverse brake piston according to the following procedures.
 - a. Set and align return springs to transmission case gutters as shown in illustration.

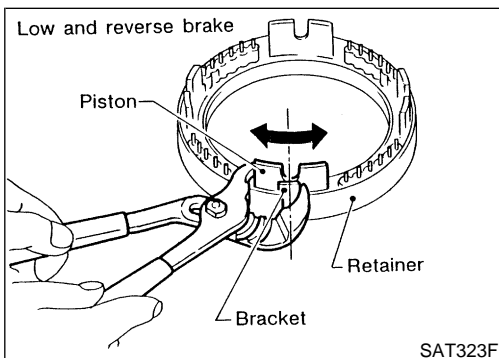

- b. Set and align piston with retainer.

ASSEMBLY

Assembly (2) (Cont'd)

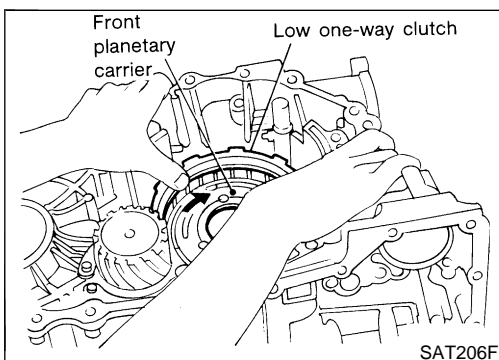
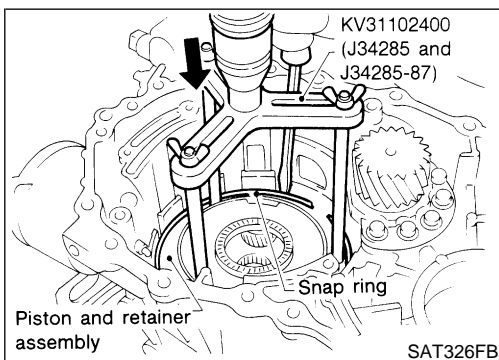
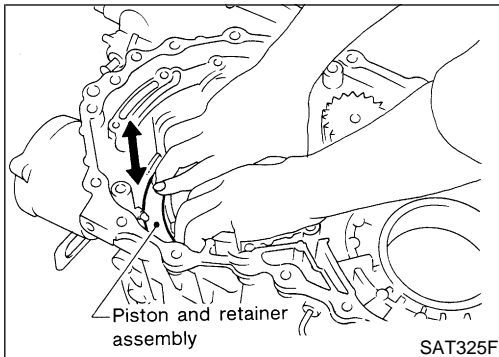
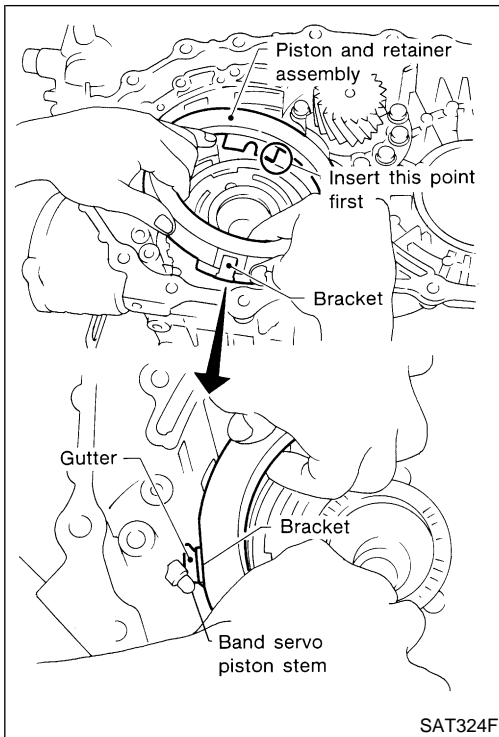

- c. Install piston and retainer assembly on the transmission case.
- **Align bracket to specified gutter as indicated in illustration.**

- d. Check that each protrusion of piston is correctly set to corresponding return spring as follows.
- **Push piston and retainer assembly evenly and confirm they move smoothly.**
 - **If they can not move smoothly, remove piston and retainer assembly and align return spring correctly as instructed in step "a".**

- e. Push down piston and retainer assembly and install snap ring.

14. Install low one-way clutch to front planetary carrier by turning carrier in the direction of the arrow shown.

GI

MA

EM

LC

EC

FE

AT

AX

SU

BR

ST

RS

BT

HA

SC

EL

IDX

ASSEMBLY

Assembly (2) (Cont'd)

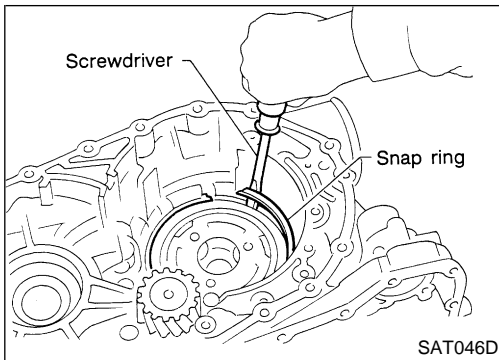

15. Install snap ring with screwdriver.
- **Forward clutch and bearing must be correctly installed for snap ring to fit into groove of transmission case.**

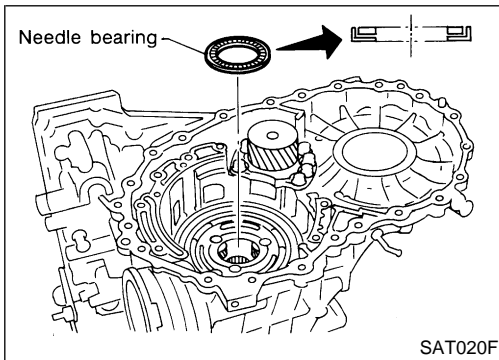

16. Install needle bearing on transmission case.
- **Apply petroleum jelly to needle bearing.**
 - **Pay attention to direction of needle bearing.**

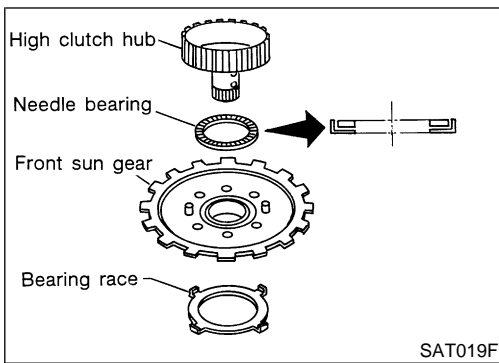

17. Install bearing race, needle bearing and high clutch hub on front sun gear.
- **Apply petroleum jelly to needle bearing.**
 - **Pay attention to direction of needle bearing.**

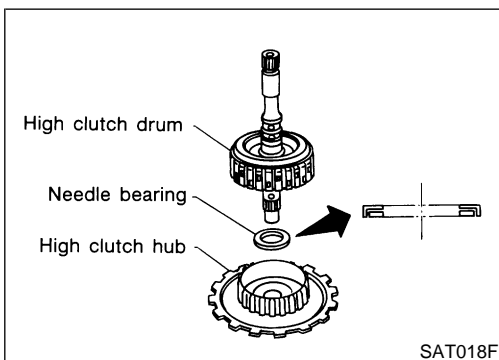

18. Install needle bearing and high clutch drum on high clutch hub.

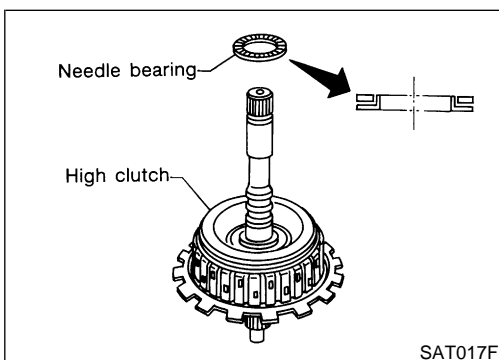

19. Install needle bearing on high clutch drum.
- **Apply petroleum jelly to needle bearing.**
 - **Pay attention to direction of needle bearing.**

ASSEMBLY

Assembly (2) (Cont'd)

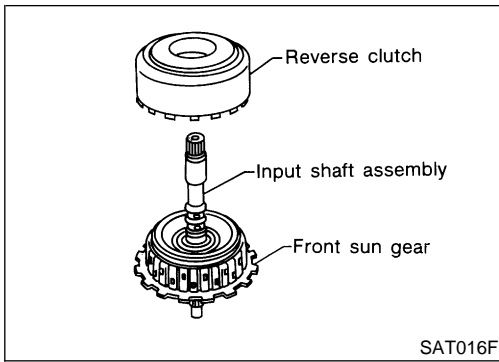

20. Remove paper rolled around input shaft.

21. Install input shaft assembly in reverse clutch.

- **Align teeth of reverse clutch drive plates before installing.**

GI

MA

EM

LC

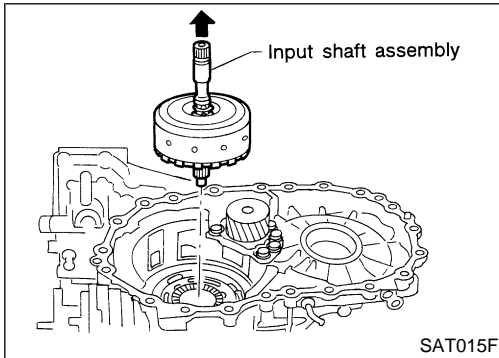

22. Install reverse clutch assembly on transmission case.

- **Align teeth of high clutch drive plates before installing.**

EC

FE

AT

AX

Adjustment (2)

NDAT0178

When any parts listed below are replaced, adjust total end play and reverse clutch end play.

SU

Part name	Total end play	Reverse clutch end play
Transmission case	●	●
Overrun clutch hub	●	●
Rear internal gear	●	●
Rear planetary carrier	●	●
Rear sun gear	●	●
Front planetary carrier	●	●
Front sun gear	●	●
High clutch hub	●	●
High clutch drum	●	●
Oil pump cover	●	●
Reverse clutch drum	—	●

BR

ST

RS

BT

HA

SC

EL

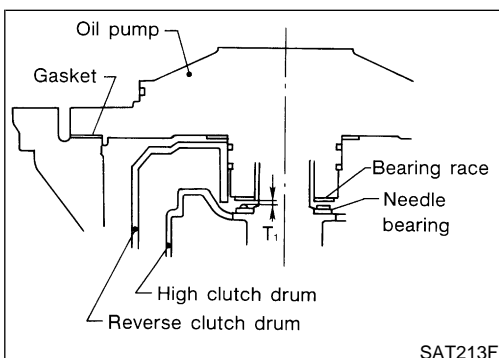

TOTAL END PLAY

NDAT0178S01

1. Adjust total end play "T₁".

IDX

ASSEMBLY

Adjustment (2) (Cont'd)

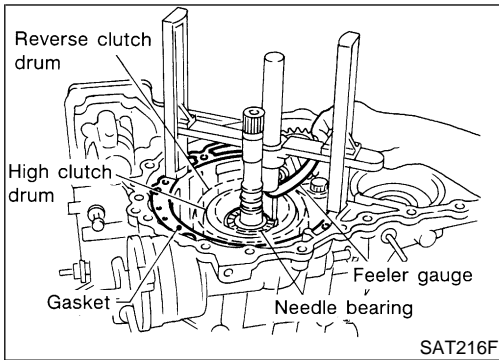
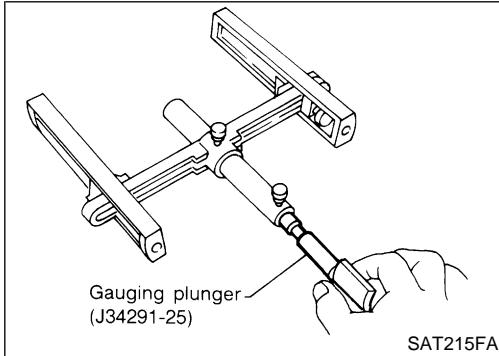
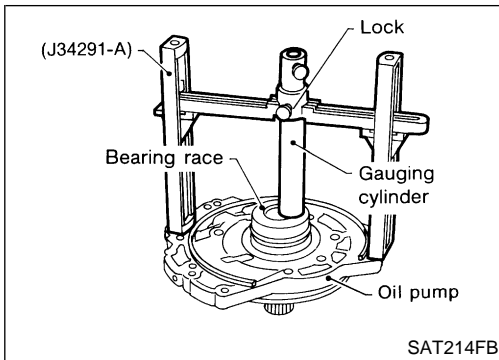

a. With original bearing race installed, place Tool onto oil pump. The long ends of legs should be placed firmly on machined surface of oil pump assembly. The gauging cylinder should rest on top of bearing race. Lock gauging cylinder in place with set screw.

b. Install gauging plunger into cylinder.

c. With needle bearing installed on high clutch drum, place Tool legs on machined surface of transmission case (with gasket). Then allow plunger to rest on needle bearing.

d. Measure gap between cylinder and plunger. This measurement should give exact total end play.

Total end play "T₁":

0.25 - 0.55 mm (0.0098 - 0.0217 in)

• If end play is out of specification, decrease or increase thickness of bearing race as necessary.

Available bearing race for adjusting total end play:

Refer to "BEARING RACE FOR ADJUSTING TOTAL END PLAY", AT-377.

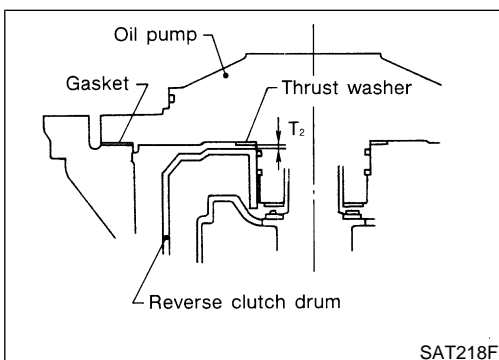

2. Adjust reverse clutch drum end play "T₂".

ASSEMBLY

Adjustment (2) (Cont'd)

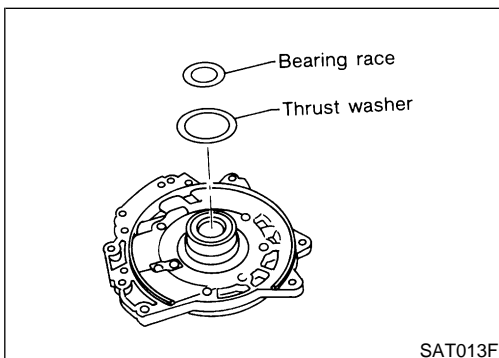
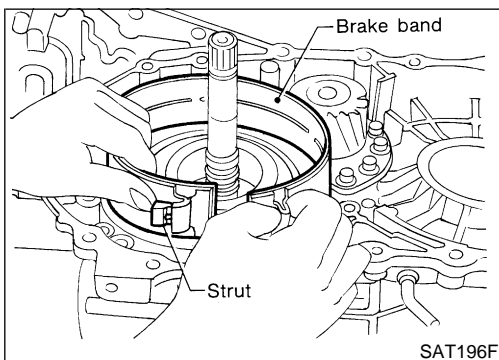
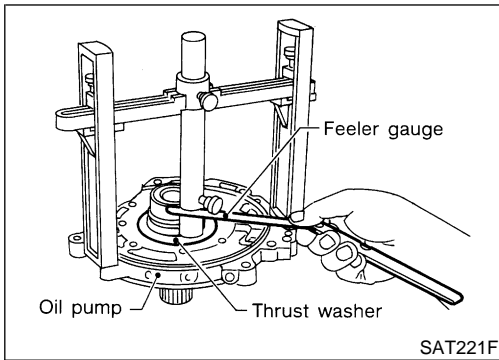
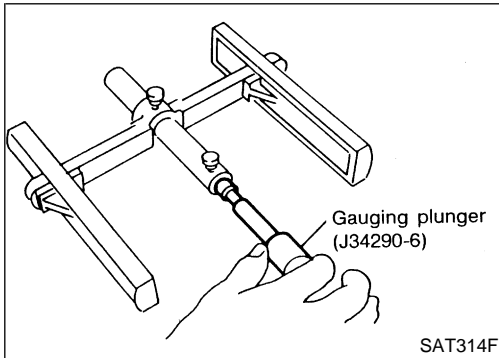
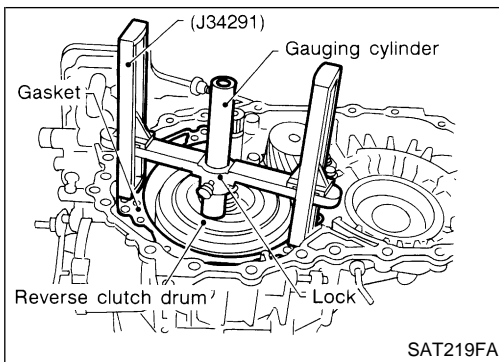

a. Place Tool on machined surface of transmission case (with gasket). Then allow gauging cylinder to rest on reverse clutch drum. Lock cylinder in place with set screw.

b. Install gauging plunger into cylinder.

c. With original thrust washer installed on oil pump, place Tool legs onto machined surface of oil pump assembly. Then allow plunger to rest on thrust washer.

d. Measure gap between cylinder and plunger with feeler gauge. This measurement should give exact reverse clutch drum end play.

**Reverse clutch drum end play "T₂":
0.55 - 0.90 mm (0.0217 - 0.0354 in)**

- If end play is out of specification, decrease or increase thickness of thrust washer as necessary.

Available thrust washer for adjusting reverse clutch drum end play:

Refer to "THRUST WASHERS FOR ADJUSTING REVERSE CLUTCH DRUM END PLAY", AT-377.

Assembly (3)

NDAT0179

1. Install anchor end pin and lock nut on transmission case.
2. Place brake band on outside of reverse clutch drum. Tighten anchor end pin just enough so that brake band is evenly fitted on reverse clutch drum.

3. Place bearing race selected in total end play adjustment step on oil pump cover.

- **Apply petroleum jelly to bearing race.**

4. Place thrust washer selected in reverse clutch end play step on reverse clutch drum.

- **Apply petroleum jelly to thrust washer.**

GI

MA

EM

LC

EC

FE

AT

AX

SU

BR

ST

RS

BT

HA

SC

EL

IDX

ASSEMBLY

Assembly (3) (Cont'd)

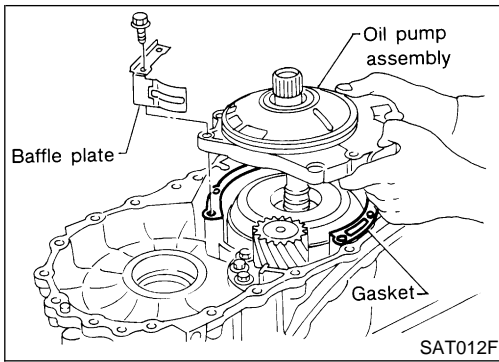

5. Install oil pump assembly, baffle plate and gasket on transmission case.
6. Tighten oil pump fixing bolts to the specified torque.

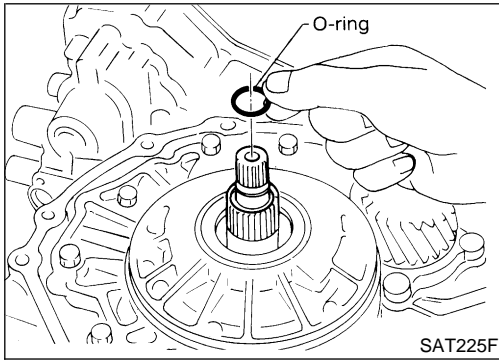

7. Install O-ring to input shaft.
 - **Apply ATF to O-ring.**

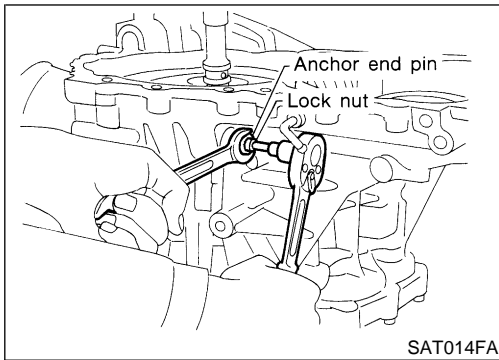

8. Adjust brake band.
 - a. Tighten anchor end pin to the specified torque.

Anchor end pin:
☞ : 3.9 - 5.9 N·m (0.4 - 0.6 kg-m, 35 - 52 in-lb)
 - b. Back off anchor end pin two and a half turns.
 - c. While holding anchor end pin, tighten lock nut.

Lock nut:
☞ : 31 - 36 N·m (3.2 - 3.7 kg-m, 23 - 27 ft-lb)

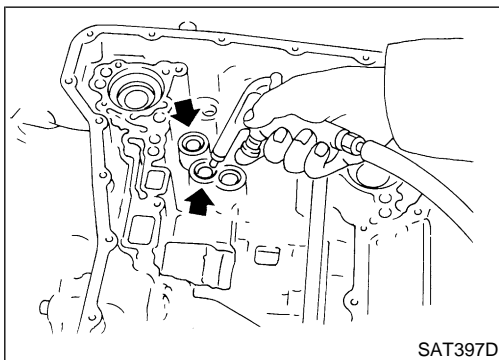

9. Apply compressed air to oil holes of transmission case and check operation of brake band.

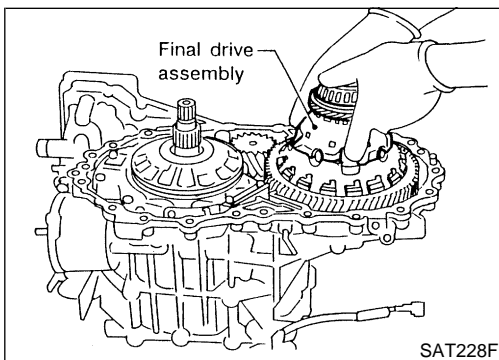

10. Install final drive assembly on transmission case.

ASSEMBLY

Assembly (3) (Cont'd)

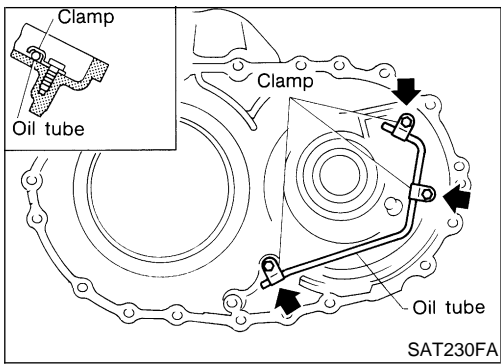

11. Install oil tube on converter housing.

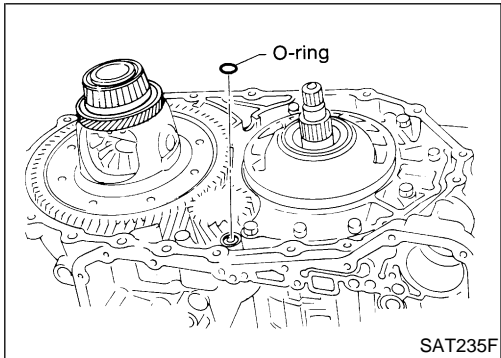

12. Install O-ring on differential oil port of transmission case.

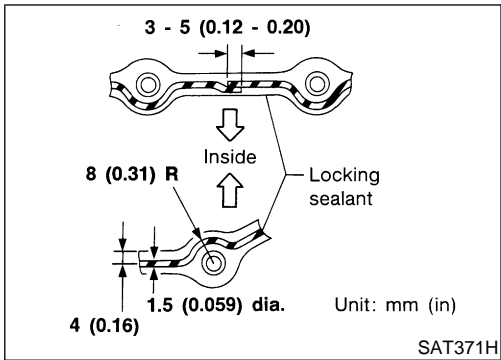

13. Install converter housing on transmission case.

- Apply locking sealant (Loctite #518) to mating surface of converter housing.

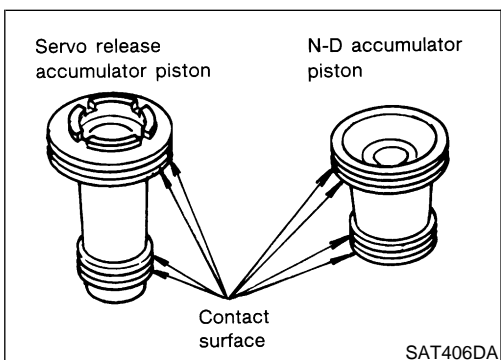
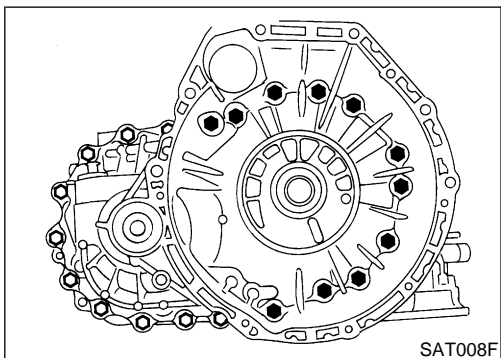

14. Install accumulator piston.

- Check contact surface of accumulator piston for damage.

GI

MA

EM

LC

EC

FE

AT

AX

SU

BR

ST

RS

BT

HA

SC

EL

IDX

ASSEMBLY

Assembly (3) (Cont'd)

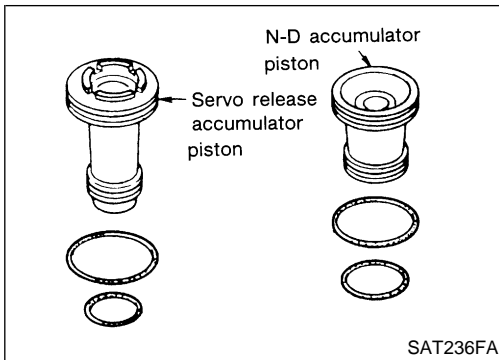

- b. Install O-rings on accumulator piston.
- **Apply ATF to O-rings.**
Accumulator piston O-rings:
Refer to "O-RING", AT-371.

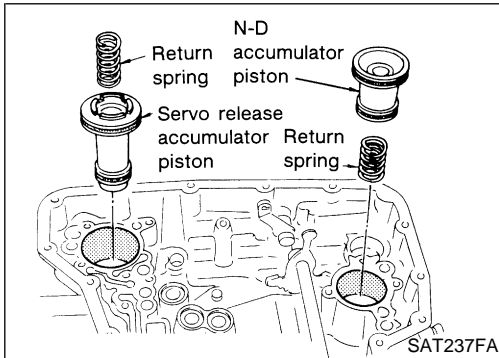

- c. Install accumulator pistons and return springs on transmission case.
- **Apply ATF to inner surface of transmission case.**
Return springs:
Refer to "RETURN SPRING", AT-371.

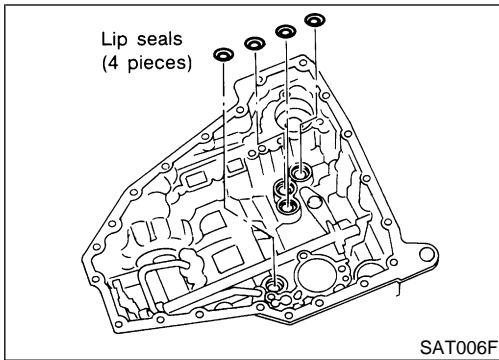

15. Install lip seals for band servo oil holes on transmission case.
- **Apply petroleum jelly to lip seals.**

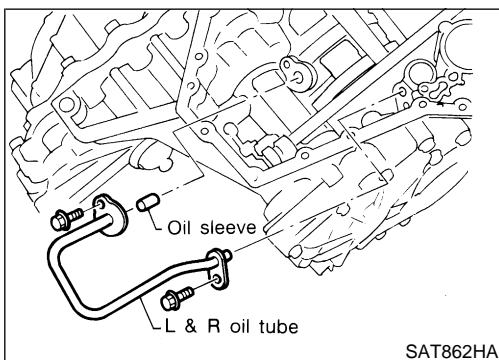

16. Install L & R oil tube and oil sleeve.
-  : 5 - 7 N·m (0.5 - 0.7 kg-m, 43 - 61 in-lb)

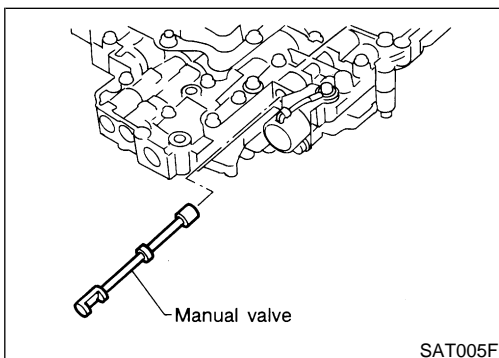

17. Install control valve assembly.
- a. Insert manual valve into control valve assembly.
- **Apply ATF to manual valve.**

ASSEMBLY

Assembly (3) (Cont'd)

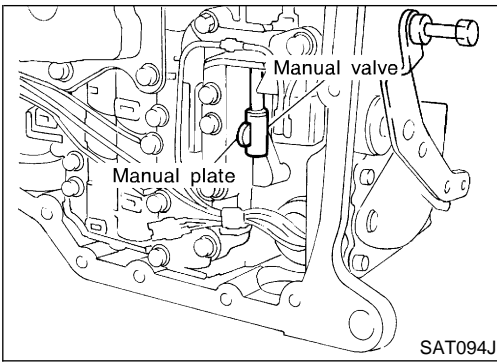

- b. Set manual shaft in Neutral position.
- c. Install control valve assembly on transmission case while aligning manual valve with manual plate.

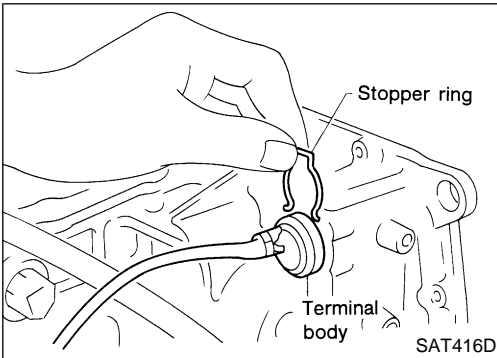

- d. Pass solenoid harness through transmission case and install terminal body on transmission case by pushing it.
- e. Install snap ring to terminal body.

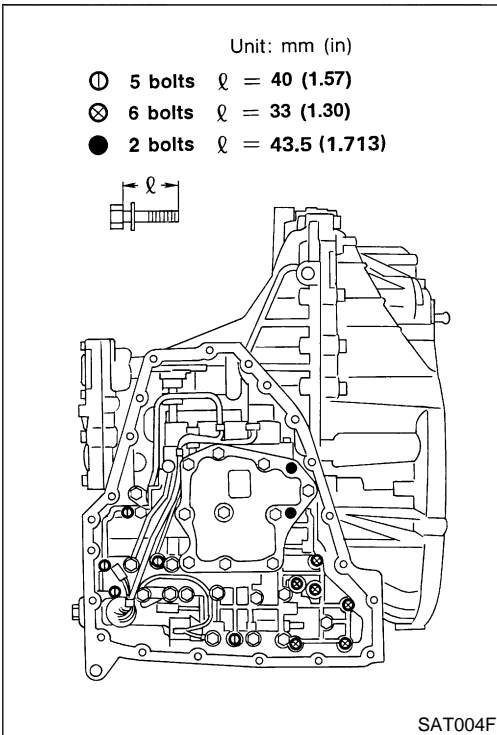

- f. Tighten bolts I, X and ●.

Bolt length, number and location:

Bolt	I	X	●
Bolt length " ℓ "  mm (in)	40.0 (1.575)	33.0 (1.299)	43.5 (1.713)
Number of bolts	5	6	2

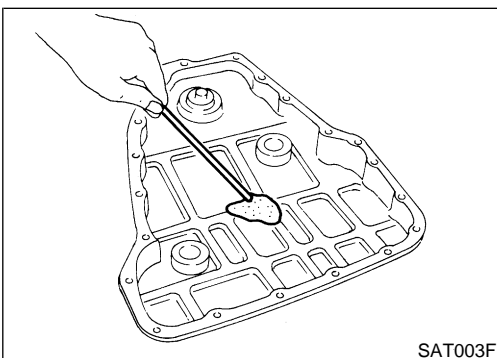

18. Install oil pan.
 - a. Attach a magnet to oil pan.
 - b. Install new oil pan gasket on transmission case.
 - c. Install oil pan on transmission case.
 - **Always replace oil pan bolts as they are self-sealing bolts.**
 - **Tighten four bolts in a crisscross pattern to prevent dislocation of gasket.**
 - d. Tighten oil pan bolts and drain plug to the specified torque. Refer to "Components", AT-276.

GI

MA

EM

LC

EC

FE

AT

AX

SU

BR

ST

RS

BT

HA

SC

EL

IDX

ASSEMBLY

Assembly (3) (Cont'd)

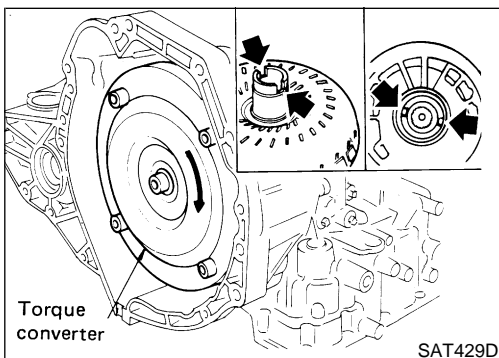
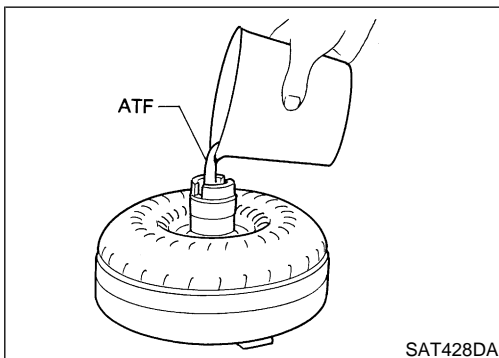
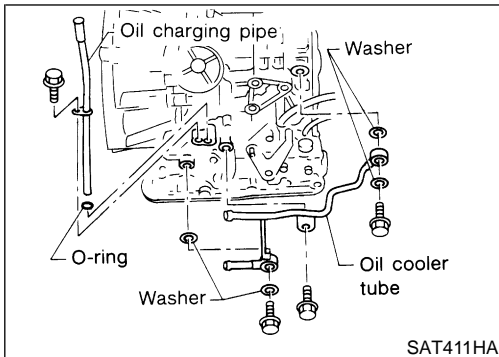
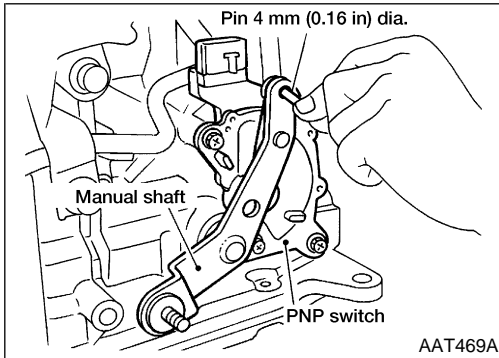
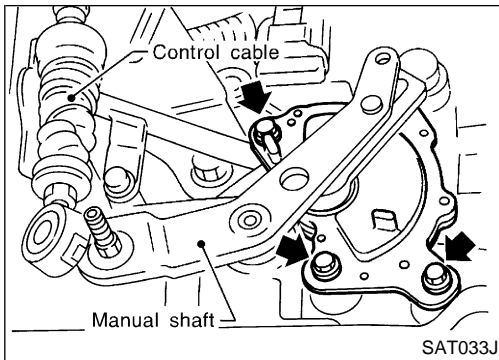

19. Install park/neutral position (PNP) switch.
 - a. Set manual shaft in P position.
 - b. Temporarily install park/neutral position (PNP) switch on manual shaft.
 - c. Move selector lever to N position.
 - d. Use a 4 mm (0.16 in) pin for this adjustment.
 - i. Insert the pin straight into the manual shaft adjustment hole.
 - ii. Rotate park/neutral position (PNP) switch until the pin can also be inserted straight into hole in park/neutral position (PNP) switch.
 - e. Tighten park/neutral position (PNP) switch fixing bolts. Refer to "Components", AT-276.
 - f. Remove pin from adjustment hole after adjusting park/neutral position (PNP) switch.
20. Install oil charging pipe and oil cooler tube to transmission case.
21. Install torque converter.
 - a. Pour ATF into torque converter.
 - **Approximately 1 liter (1-1/8 US qt, 7/8 Imp qt) of fluid is required for a new torque converter.**
 - **When reusing old torque converter, add the same amount of fluid as was drained.**
 - b. Install torque converter while aligning notches of torque converter with notches of oil pump.

ASSEMBLY

Assembly (3) (Cont'd)

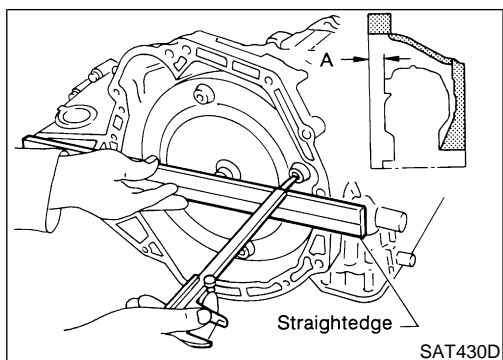

- c. Measure distance "A" to check that torque converter is in proper position.

Distance A: 14 mm (0.55 in) or more

GI

MA

EM

LC

EC

FE

AT

AX

SU

BR

ST

RS

BT

HA

SC

EL

IDX

SERVICE DATA AND SPECIFICATIONS (SDS)

General Specifications

General Specifications

NDAT0180

Engine	VG33E	
Automatic transaxle model	RE4F04A	
Automatic transaxle assembly	Model code number	80X77
Transaxle gear ratio	1st	2.785
	2nd	1.545
	3rd	1.000
	4th	0.694
	Reverse	2.272
	Final drive	3.789
Recommended fluid	NISSAN Matic "D" (Continental U.S. and Alaska) or Canada NISSAN Automatic Transmission Fluid *1	
Fluid capacity ℓ(US qt, Imp qt)	9.4 (10, 8-1/4)	

*1: Refer to **MA-11**, "Fluids and Lubricants".

Shift Schedule

NDAT0181

VEHICLE SPEED WHEN SHIFTING GEARS THROTTLE POSITION

NDAT0181S01

Throttle position	Shift pattern	Vehicle speed km/h (MPH)						
		D ₁ → D ₂	D ₂ → D ₃	D ₃ → D ₄	D ₄ → D ₃	D ₃ → D ₂	D ₂ → D ₁	1 ₂ → 1 ₁
Full throttle	Comfort	56 - 64 (35 - 40)	102 - 110 (63 - 68)	165 - 173 (103 - 108)	161 - 169 (100 - 105)	92 - 100 (57 - 62)	41 - 49 (25 - 30)	56 - 64 (35 - 40)
Half throttle	Comfort	36 - 44 (22 - 27)	50 - 66 (31 - 41)	128 - 136 (80 - 85)	69 - 77 (43 - 48)	33 - 41 (21 - 25)	6 - 14 (4 - 9)	56 - 64 (35 - 40)

VEHICLE SPEED WHEN PERFORMING AND RELEASING LOCK-UP

NDAT0181S02

Throttle position	Shift pattern	OD switch	Gear position	Vehicle speed km/h (MPH)	
				Lock-up ON	Lock-up OFF
2.0/8	Comfort	ON	D ₄	97 - 105 (60 - 65)	77 - 85 (48 - 53)
		OFF	D ₃	86 - 94 (53 - 58)	83 - 91 (52 - 57)

Stall Revolution

NDAT0182

Engine	Stall revolution rpm
VG33E	1,900 - 2,200

Line Pressure

NDAT0183

Engine speed rpm	Line pressure kPa (kg/cm ² , psi)	
	D, 2 and 1 positions	R position
Idle	500 (5.1, 73)	779 (7.95, 113.0)
Stall	1,233 (12.6, 179)	1,918 (19.6, 278)

SERVICE DATA AND SPECIFICATIONS (SDS)

Control Valves

Control Valves

CONTROL VALVE AND PLUG RETURN SPRINGS

NDAT0184

NDAT0184S01
Unit: mm (in)

	Parts		Item		
			Part number*	Free length	Outer diameter
Upper body	18	Pilot valve spring	31742-80L05	36.0 (1.417)	8.1 (0.319)
	8	1-2 accumulator valve spring (small)	31742-80L06	20.5 (0.807)	7.0 (0.276)
	21	1-2 accumulator piston spring (large)	31742-80L07	49.25 (1.9390)	19.6 (0.772)
	25	1st reducing valve spring	31742-80L08	27.0 (1.063)	7.0 (0.276)
	16	Overrun clutch reducing valve spring	31742-80L09	37.5 (1.476)	6.9 (0.272)
	11	Torque converter relief valve spring	31742-80L10	31.0 (1.220)	9.0 (0.354)
	4	Torque converter clutch control valve spring	31742-80L11	39.5 (1.555)	11.0 (0.433)
Lower body	16	Pressure regulator valve spring	31742-80L01	45.0 (1.772)	15.0 (0.591)
	21	Overrun clutch control valve spring	31762-80L00	21.7 (0.854)	7.0 (0.276)
	25	Accumulator control valve spring	31742-80L02	22.0 (0.866)	6.5 (0.256)
	30	Shift valve A spring	31762-80L00	21.7 (0.854)	7.0 (0.276)
	12	Shift valve B spring	31762-80L00	21.7 (0.854)	7.0 (0.276)
	7	Pressure modifier valve spring	31742-80L03	30.5 (1.201)	9.8 (0.386)
	3		31742-80L04	32.0 (1.260)	6.9 (0.272)
	13	Return spring	31742-80L00	17.0 (0.669)	10.7 (0.421)
	—	Oil cooler relief valve spring	31742-80L12	17.02 (0.670)	8.0 (0.315)

*: Always check with the Parts Department for the latest parts information.

Accumulator

O-RING

NDAT0185

NDAT0185S01
Unit: mm (in)

Accumulator	Part number*	Inner diameter (Small)	Part number*	Inner diameter (Large)
Servo release accumulator	31526-41X03	26.9 (1.059)	31526-41X02	44.2 (1.740)
N-D accumulator	31526-31X08	34.6 (1.362)	31672-21X00	39.4 (1.551)

*: Always check with the Parts Department for the latest parts information.

RETURN SPRING

NDAT0185S02
Unit: mm (in)

Accumulator	Part number*	Free length	Outer diameter
Servo release accumulator	31605-80L02	52.5 (2.067)	20.4 (0.803)
N-D accumulator	31605-80L03	43.5 (1.713)	28.0 (1.102)

*: Always check with the Parts Department for the latest parts information.

SERVICE DATA AND SPECIFICATIONS (SDS)

Clutch and Brakes

Clutch and Brakes

NDAT0186

REVERSE CLUTCH

NDAT0186S01

Number of drive plates		2
Number of driven plates		2
Drive plate thickness mm (in)	Standard	1.6 (0.063)
	Allowable limit	1.4 (0.055)
Clearance mm (in)	Standard	0.5 - 0.8 (0.020 - 0.031)
	Allowable limit	1.2 (0.047)
Thickness of retaining plates	Thickness mm (in)	Part number *
	6.6 (0.260)	31537-80L00
	6.8 (0.268)	31537-80L01
	7.0 (0.276)	31537-80L02
	7.2 (0.283)	31537-80L03
	7.4 (0.291)	31537-80L04
	7.6 (0.299)	31537-80L05
7.8 (0.307)	31537-80L06	

*: Always check with the Parts Department for the latest parts information.

HIGH CLUTCH

NDAT0186S02

Number of drive plates		4
Number of driven plates		6 + 1
Drive plate thickness mm (in)	Standard	1.6 (0.063)
	Allowable limit	1.4 (0.055)
Clearance mm (in)	Standard	1.8 - 2.2 (0.071 - 0.087)
	Allowable limit	3.0 (0.118)
Thickness of retaining plates	Thickness mm (in)	Part number *
	3.0 (0.118)	31537-80L19
	3.2 (0.126)	31537-80L20
	3.4 (0.134)	31537-80L21
	3.6 (0.142)	31537-80L22
	3.8 (0.150)	31537-80L23

*: Always check with the Parts Department for the latest parts information.

FORWARD CLUTCH

NDAT0186S03

Number of drive plates		6
Number of driven plates		6
Drive plate thickness mm (in)	Standard	1.6 (0.063)
	Allowable limit	1.4 (0.055)
Clearance mm (in)	Standard	0.45 - 0.85 (0.0177 - 0.0335)
	Allowable limit	2.05 (0.0807)
Thickness of retaining plates	Thickness mm (in)	Part number *
	3.2 (0.126)	31537-80L18
	3.4 (0.134)	31537-80L17
	3.6 (0.142)	31537-80L12
	3.8 (0.150)	31537-80L13
	4.0 (0.157)	31537-80L14
	4.2 (0.165)	31537-80L15
4.4 (0.173)	31537-80L16	

*: Always check with the Parts Department for the latest parts information.

SERVICE DATA AND SPECIFICATIONS (SDS)

Clutch and Brakes (Cont'd)

OVERRUN CLUTCH

NDAT0186S04

Number of drive plates		3	GI
Number of driven plates		5	
Drive plate thickness mm (in)	Standard	1.6 (0.063)	MA
	Allowable limit	1.4 (0.055)	
Clearance mm (in)	Standard	0.7 - 1.1 (0.028 - 0.043)	EM
	Allowable limit	1.7 (0.067)	
Thickness of retaining plates	Thickness mm (in)	Part number *	LC
	3.0 (0.118)	31537-80L07	
	3.2 (0.126)	31537-80L08	
	3.4 (0.134)	31537-80L09	EC
	3.6 (0.142)	31537-80L10	
	3.8 (0.150)	31537-80L11	FE

*: Always check with the Parts Department for the latest parts information.

LOW & REVERSE BRAKE

NDAT0186S05

Number of drive plates		7	AT
Number of driven plates		7	
Drive plate thickness mm (in)	Standard	1.8 (0.071)	AX
	Allowable limit	1.6 (0.063)	
Clearance mm (in)	Standard	1.7 - 2.1 (0.067 - 0.083)	SU
	Allowable limit	3.5 (0.138)	
Thickness of retaining plates	Thickness mm (in)	Part number *	BR
	2.0 (0.079)	31667-80L00	
	2.2 (0.087)	31667-80L01	ST
	2.4 (0.094)	31667-80L02	
	2.6 (0.102)	31667-80L03	
	2.8 (0.110)	31667-80L04	
	3.0 (0.118)	31667-80L05	RS
	3.2 (0.126)	31667-80L06	
	3.4 (0.134)	31667-80L07	BT

*: Always check with the Parts Department for the latest parts information.

BRAKE BAND

NDAT0186S06

Anchor end pin tightening torque N-m (kg-m, in-lb)	3.5 - 5.9 (0.36 - 0.6, 31 - 52)	HA
Number of returning revolutions for anchor end pin	2.5	SC
Lock nut tightening torque N-m (kg-m, ft-lb)	31 - 36 (3.2 - 3.7, 23 - 27)	

Final Drive

DIFFERENTIAL SIDE GEAR CLEARANCE

NDAT0187

NDAT0187S01

Clearance between side gear and differential case with washer mm (in)	0.1 - 0.2 (0.004 - 0.008)	EL
---	---------------------------	----

DIFFERENTIAL SIDE GEAR THRUST WASHERS

NDAT0187S02

Thickness mm (in)	Part number *	IDX
0.75 (0.0295)	38424-81X00	
0.80 (0.0315)	38424-81X01	
0.85 (0.0335)	38424-81X02	
0.90 (0.0354)	38424-81X03	
0.95 (0.0374)	38424-81X04	

*: Always check with the Parts Department for the latest parts information.

SERVICE DATA AND SPECIFICATIONS (SDS)

Final Drive (Cont'd)

DIFFERENTIAL SIDE BEARING PRELOAD ADJUSTING SHIMS

NDAT0187S03

Thickness mm (in)	Part number *
0.48 (0.0189)	31438-80X00
0.52 (0.0205)	31438-80X01
0.56 (0.0220)	31438-80X02
0.60 (0.0236)	31438-80X03
0.64 (0.0252)	31438-80X04
0.68 (0.0268)	31438-80X05
0.72 (0.0283)	31438-80X06
0.76 (0.0299)	31438-80X07
0.80 (0.0315)	31438-80X08
0.84 (0.0331)	31438-80X09
0.88 (0.0346)	31438-80X10
0.92 (0.0362)	31438-80X11

*: Always check with the Parts Department for the latest parts information.

BEARING PRELOAD

NDAT0187S04

Differential side bearing preload mm (in)	0.05 - 0.09 (0.0020 - 0.0035)
---	-------------------------------

TURNING TORQUE

NDAT0187S05

Turning torque of final drive assembly N-m (kg-cm, in-lb)	0.78 - 1.37 (8.0 - 14.0, 6.9 - 12.2)
---	--------------------------------------

CLUTCH AND BRAKE RETURN SPRINGS

NDAT0187S06
Unit: mm (in)

Parts	Part number*	Free length	Outer diameter
Forward clutch (Overrun clutch) (22 pcs)	31505-80L00	21.4 (0.843)	10.3 (0.406)
High clutch (12 pcs)	31505-80L02	22.5 (0.886)	10.8 (0.425)
Low & reverse brake (24 pcs)	31505-80L01	24.1 (0.949)	6.6 (0.260)

*: Always check with the Parts Department for the latest parts information.

Planetary Carrier and Oil Pump

NDAT0188

PLANETARY CARRIER

NDAT0188S01

Clearance between planetary carrier and pinion washer mm (in)	Standard	0.20 - 0.70 (0.0079 - 0.0276)
	Allowable limit	0.80 (0.0315)

SERVICE DATA AND SPECIFICATIONS (SDS)

Planetary Carrier and Oil Pump (Cont'd)

OIL PUMP

NDAT0188S02

Oil pump side clearance mm (in)	0.030 - 0.050 (0.0012 - 0.0020)	
Thickness of inner gears and outer gears	Inner gear	
	Thickness mm (in)	Part number *
	11.99 - 12.0 (0.4720 - 0.4724)	31346-80L00
	11.98 - 11.99 (0.4717 - 0.4720)	31346-80L01
	11.97 - 11.98 (0.4713 - 0.4717)	31346-80L02
	Outer gear	
Thickness mm (in)	Part number*	
11.99 - 12.0 (0.4720 - 0.4724)	31347-80L00	
11.98 - 11.99 (0.4717 - 0.4720)	31347-80L01	
11.97 - 11.98 (0.4713 - 0.4717)	31347-80L02	
Clearance between oil pump housing and outer gear mm (in)	Standard	0.111 - 0.181 (0.0044 - 0.0071)
	Allowable limit	0.181 (0.0071)
Oil pump cover seal ring clearance mm (in)	Standard	0.1 - 0.25 (0.0039 - 0.0098)
	Allowable limit	0.25 (0.0098)

*: Always check with the Parts Department for the latest parts information.

Input Shaft

NDAT0189

Input shaft seal ring clearance mm (in)	Standard	0.08 - 0.23 (0.0031 - 0.0091)
	Allowable limit	0.23 (0.0091)

Reduction Pinion Gear

NDAT0190

TURNING TORQUE

NDAT0190S01

Turning torque of reduction pinion gear N-m (kg-cm, in-lb)	0.05 - 0.39 (0.5 - 4.0, 0.43 - 3.47)
--	--------------------------------------

REDUCTION PINION GEAR BEARING ADJUSTING SHIMS

NDAT0190S02

NO.	Thickness mm (in)	Part number*	NO.	Thickness mm (in)	Part number *
1	5.00 (0.1969)	31439-81X00	39	5.76 (0.2268)	31439-81X69
2	5.02 (0.1976)	31439-81X01	40	5.78 (0.2276)	31439-81X70
3	5.04 (0.1984)	31439-81X02	41	5.80 (0.2283)	31439-81X71
4	5.06 (0.1992)	31439-81X03	42	5.82 (0.2291)	31439-81X72
5	5.08 (0.2000)	31439-81X04	43	5.84 (0.2299)	31439-81X73
6	5.10 (0.2008)	31439-81X05	44	5.86 (0.2307)	31439-81X74
7	5.12 (0.2016)	31439-81X06	45	5.88 (0.2315)	31439-81X75
8	5.14 (0.2024)	31439-81X07	46	5.90 (0.2323)	31439-81X76
9	5.16 (0.2031)	31439-81X08	47	5.92 (0.2331)	31439-81X77
10	5.18 (0.2039)	31439-81X09	48	5.94 (0.2339)	31439-81X78
11	5.20 (0.2047)	31439-81X10	49	5.96 (0.2346)	31439-81X79
12	5.22 (0.2055)	31439-81X11	50	5.98 (0.2354)	31439-81X80
13	5.24 (0.2063)	31439-81X12	51	6.00 (0.2362)	31439-81X81
14	5.26 (0.2071)	31439-81X13	52	4.50 (0.1772)	31439-83X00
15	5.28 (0.2079)	31439-81X14	53	4.52 (0.1780)	31439-83X01
16	5.30 (0.2087)	31439-81X15	54	4.54 (0.1787)	31439-83X02

SERVICE DATA AND SPECIFICATIONS (SDS)

Reduction Pinion Gear (Cont'd)

NO.	Thickness mm (in)	Part number*	NO.	Thickness mm (in)	Part number *
17	5.32 (0.2094)	31439-81X16	55	4.56 (0.1795)	31439-83X03
18	5.34 (0.2102)	31439-81X17	56	4.58 (0.1803)	31439-83X04
19	5.36 (0.2110)	31439-81X18	57	4.60 (0.1811)	31439-83X05
20	5.38 (0.2118)	31439-81X19	58	4.62 (0.1819)	31439-83X06
21	5.40 (0.2126)	31439-81X20	59	4.64 (0.1827)	31439-83X07
22	5.42 (0.2134)	31439-81X21	60	4.66 (0.1835)	31439-83X08
23	5.44 (0.2142)	31439-81X22	61	4.68 (0.1843)	31439 83X09
24	5.46 (0.2150)	31439-81X23	62	4.70 (0.1850)	31439 83X10
25	5.48 (0.2157)	31439-81X24	63	4.72 (0.1858)	31439 83X11
26	5.50 (0.2165)	31439-81X46	64	4.74 (0.1866)	31439 83X12
27	5.52 (0.2173)	31439-81X47	65	4.76 (0.1874)	31439 83X13
28	5.54 (0.2181)	31439-81X48	66	4.78 (0.1882)	31439 83X14
29	5.56 (0.2189)	31439-81X49	67	4.80 (0.1890)	31439 83X15
30	5.58 (0.2197)	31439-81X60	68	4.82 (0.1898)	31439 83X16
31	5.60 (0.2205)	31439-81X61	69	4.84 (0.1906)	31439 83X17
32	5.62 (0.2213)	31439-81X62	70	4.86 (0.1913)	31439 83X18
33	5.64 (0.2220)	31439-81X63	71	4.88 (0.1921)	31439 83X19
34	5.66 (0.2228)	31439-81X64	72	4.90 (0.1929)	31439 83X20
35	5.68 (0.2236)	31439-81X65	73	4.92 (0.1937)	31439 83X21
36	5.70 (0.2244)	31439-81X66	74	4.94 (0.1945)	31439 83X22
37	5.72 (0.2252)	31439-81X67	75	4.96 (0.1953)	31439 83X23
38	5.74 (0.2260)	31439-81X68	76	4.98 (0.1961)	31439 83X24

*: Always check with the Parts Department for the latest parts information.

Band Servo

RETURN SPRING

NDAT0191

NDAT0191S01
Unit: mm (in)

Return spring	Free length	Outer diameter
2nd servo return spring	32.5 (1.280)	25.9 (1.020)
OD servo return spring	31.0 (1.220)	21.7 (0.854)

Output Shaft

SEAL RING CLEARANCE

NDAT0192

NDAT0192S01

Output shaft seal ring clearance mm (in)	Standard	0.10 - 0.25 (0.0039 - 0.0098)
	Allowable limit	0.25 (0.0098)

END PLAY

NDAT0192S02

Output shaft end play mm (in)	0 - 0.15 (0 - 0.0059)
-------------------------------	-----------------------

SERVICE DATA AND SPECIFICATIONS (SDS)

Output Shaft (Cont'd)

OUTPUT SHAFT ADJUSTING SHIMS

NDAT0192S03

Thickness mm (in)	Part number *
0.80 (0.0315)	31438-80X60
0.84 (0.0331)	31438-80X61
0.88 (0.0346)	31438-80X62
0.92 (0.0362)	31438-80X63
0.96 (0.0378)	31438-80X64
1.00 (0.0394)	31438-80X65
1.04 (0.0409)	31438-80X66
1.08 (0.0425)	31438-80X67
1.12 (0.0441)	31438-80X68
1.16 (0.0457)	31438-80X69
1.20 (0.0472)	31438-80X70

*: Always check with the Parts Department for the latest parts information.

Bearing Retainer

NDAT0193

SEAL RING CLEARANCE

NDAT0193S01

Bearing retainer seal ring clearance mm (in)	Standard	0.10 - 0.30 (0.0039 - 0.0118)
	Allowable limit	0.30 (0.0118)

Total End Play

NDAT0194

Total end play "T ₁ " mm (in)	0.25 - 0.55 (0.0098 - 0.0217)

BEARING RACE FOR ADJUSTING TOTAL END PLAY

NDAT0194S01

Thickness mm (in)	Part number *
0.8 (0.031)	31435-80X00
1.0 (0.039)	31435-80X01
1.2 (0.047)	31435-80X02
1.4 (0.055)	31435-80X03
1.6 (0.063)	31435-80X04
1.8 (0.071)	31435-80X05
2.0 (0.079)	31435-80X06
0.9 (0.035)	31435-80X09
1.1 (0.043)	31435-80X10
1.3 (0.051)	31435-80X11
1.5 (0.059)	31435-80X12
1.7 (0.067)	31435-80X13
1.9 (0.075)	31435-80X14

*: Always check with the Parts Department for the latest parts information.

Reverse Clutch End Play

NDAT0195

Reverse clutch end play mm (in)	0.55 - 0.90 (0.0217 - 0.0354)

THRUST WASHERS FOR ADJUSTING REVERSE CLUTCH DRUM END PLAY

NDAT0195S01

Thickness mm (in)	Part number *
0.80 (0.0315)	31508-80X13
0.95 (0.0374)	31508-80X14
1.10 (0.0433)	31508-80X15
1.25 (0.0492)	31508-80X16
1.40 (0.0551)	31508-80X17
1.55 (0.0610)	31508-80X18
1.70 (0.0669)	31508-80X19
1.85 (0.0728)	31508-80X20

*: Always check with the Parts Department for the latest parts information.

SERVICE DATA AND SPECIFICATIONS (SDS)

Removal and Installation

Removal and Installation

Unit: mm (in) NDAT0196

Distance between end of converter housing and torque converter	14 (0.55)
--	-----------

Shift Solenoid Valves

NDAT0221

Gear	Solenoid A	Solenoid B
1 st	ON	ON
2 nd	OFF	ON
3 rd	OFF	OFF
4 th	ON	OFF

Solenoid Valves

NDAT0222

Solenoid Valve	Resistance (Approx.)	Terminal Number
Shift Solenoid A	20–40Ω	2
Shift Solenoid B	20–40Ω	1
Overrun Clutch Solenoid	20–40Ω	3
Line Pressure Solenoid	2.5–5Ω	4
Torque Converter Clutch Solenoid	10–20Ω	5

A/T Fluid Temperature Sensor

NDAT0223

Monitor item	Condition	Specification (Approx.)	
A/T fluid temperature sensor	Cold [68° F (20° C)]	1.5V	2.5kΩ
	↓ Hot [176° F (80° C)]	↓ 0.5V	↓ 0.3kΩ

Revolution Sensor

NDAT0224

Resistance	500–650 Ω
------------	-----------

Dropping Resistor

NDAT0225

Resistance	10–15 Ω
------------	---------