

MAINTENANCE

SECTION MA

GI

MA

EM

LC

EC

FE

AT

AX

SU

BR

ST

RS

BT

HA

SC

EL

IDX

CONTENTS

| | | | |
|-----------------------------------------------------------------------------------|----|----------------------------------------------------------------------|----|
| PRECAUTIONS | 2 | CHASSIS AND BODY MAINTENANCE | 24 |
| Supplemental Restraint System (SRS) "AIR BAG" and "SEAT BELT PRE-TENSIONER" | 2 | Checking Exhaust System..... | 24 |
| PREPARATION | 3 | Checking A/T Fluid | 24 |
| Special Service Tool | 3 | Changing A/T Fluid | 25 |
| Commercial Service Tool..... | 3 | Balancing Wheels | 25 |
| Preparation for Changing Engine Coolant | 3 | Tire Rotation | 25 |
| GENERAL MAINTENANCE | 4 | Checking Brake Fluid Level and Leaks..... | 25 |
| PERIODIC MAINTENANCE | 6 | Checking Brake Lines and Cables | 26 |
| Schedule 1 | 7 | Checking Disc Brake | 26 |
| EMISSION CONTROL SYSTEM MAINTENANCE | 7 | ROTOR..... | 26 |
| CHASSIS AND BODY MAINTENANCE..... | 8 | CALIPER..... | 26 |
| Schedule 2..... | 9 | PAD..... | 26 |
| EMISSION CONTROL SYSTEM MAINTENANCE | 9 | Checking Drum Brake | 26 |
| CHASSIS AND BODY MAINTENANCE..... | 10 | WHEEL CYLINDER..... | 26 |
| RECOMMENDED FLUIDS AND LUBRICANTS | 11 | DRUM..... | 26 |
| Fluids and Lubricants | 11 | LINING..... | 27 |
| SAE Viscosity Number | 12 | TEMPORARY METHOD FOR CHECKING LINING WEAR..... | 27 |
| GASOLINE ENGINE OIL | 12 | Checking Steering Gear, Linkage..... | 27 |
| Anti-freeze Coolant Mixture Ratio | 12 | STEERING GEAR..... | 27 |
| ENGINE MAINTENANCE | 13 | STEERING LINKAGE | 27 |
| Checking Drive Belts | 13 | Checking Power Steering Fluid and Lines..... | 27 |
| Changing Engine Coolant..... | 14 | CHECKING FLUID LEVEL | 27 |
| Flushing Cooling System..... | 18 | CHECKING LINES | 27 |
| Checking Fuel Lines | 18 | Lubricating Locks, Hinges and Hood Latches..... | 28 |
| Changing Fuel Filter | 18 | Checking Seat Belts, Buckles, Retractors, Anchors and Adjusters..... | 28 |
| ☑ WITH CONSULT-II | 18 | SERVICE DATA AND SPECIFICATIONS (SDS) | 29 |
| ☒ WITHOUT CONSULT-II | 19 | Engine Maintenance | 29 |
| Changing Air Cleaner Filter | 19 | DRIVE BELT DEFLECTION | 29 |
| VISCOUS PAPER TYPE..... | 19 | DRIVE BELT TENSION | 29 |
| Changing Engine Oil..... | 19 | SPARK PLUG TYPE | 29 |
| Changing Oil Filter..... | 20 | Chassis and Body Maintenance..... | 29 |
| Changing Spark Plugs..... | 21 | WHEEL BALANCE | 29 |
| Checking EVAP Vapor Lines | 23 | | |

PRECAUTIONS

Supplemental Restraint System (SRS) "AIR BAG" and "SEAT BELT PRE-TENSIONER"

Supplemental Restraint System (SRS) "AIR BAG" and "SEAT BELT PRE-TENSIONER"

NDMA0001

The Supplemental Restraint System such as "AIR BAG" and "SEAT BELT PRE-TENSIONER" used along with a seat belt, helps to reduce the risk or severity of injury to the driver and front passenger for certain types of collision. The Supplemental Restraint System consists of driver air bag module (located in the center of the steering wheel), front passenger air bag module (located on the instrument panel on passenger side), seat belt pre-tensioners, a diagnosis sensor unit, warning lamp, wiring harness and spiral cable.

Information necessary to service the system safely is included in the **RS section** of this Service Manual.

WARNING:

- To avoid rendering the SRS inoperative, which could increase the risk of personal injury or death in the event of a collision which would result in air bag inflation, all maintenance should be performed by an authorized NISSAN dealer.
- Improper maintenance, including incorrect removal and installation of the SRS, can lead to personal injury caused by unintentional activation of the system. For removal of Spiral Cable and Air Bag Module, see the RS section.
- Do not use electrical test equipment on any circuit related to the SRS unless instructed to in this Service Manual. Spiral cable and wiring harnesses (except "SEAT BELT PRE-TENSIONER") covered with yellow insulation either just before the harness connectors or for the complete harness are related to the SRS.

PREPARATION

Special Service Tool

Special Service Tool

NDMA0002

The actual shapes of Kent-Moore tools may differ from those of special service tools illustrated here.

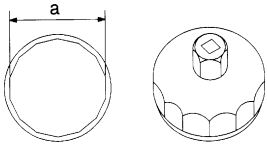
| Tool number (Kent-Moore No.) Tool name | Description |
|-------------------------------------------------|----------------------------------------------------------------------------------------------------------------------------------------------------------------------------------------------------------------------------------------------------------------------------------------------------------------------------------|
| KV10115801 (J38956) Oil filter cap wrench | <div style="display: flex; align-items: center; justify-content: center;">  <div style="margin-left: 20px;"> <p>Removing oil filter a: 64.3 mm (2.531 in)</p> </div> </div> <p style="text-align: left; margin-top: 10px;">NT375</p> |

GI

MA

EM

LC

Commercial Service Tool

NDMA0011

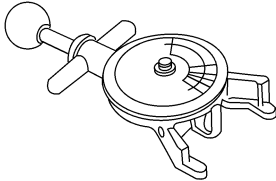
| Tool name (Kent-Moore No.) | Description |
|----------------------------------|-----------------------------------------------------------------------------------------------------------------------------------------------------------------------------------------------------------------------------------------------------------------------------------------------------------|
| Belt tension gauge (BT3373-F) | <div style="display: flex; align-items: center; justify-content: center;">  <div style="margin-left: 20px;"> <p>Measuring drive belt tension</p> </div> </div> <p style="text-align: left; margin-top: 10px;">AMA126</p> |

EC

FE

AT

AX

SU

BR

ST

RS

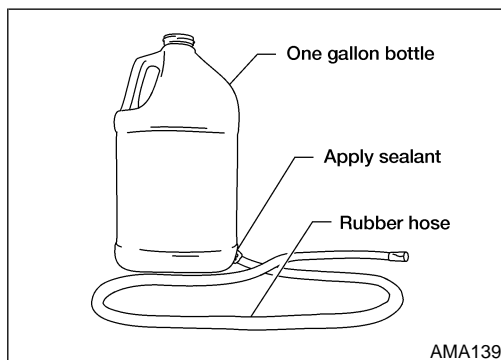

Preparation for Changing Engine Coolant

NDMA0012

Prepare an empty one gallon bottle, such as used for windshield washer fluid. Obtain a 1371 mm (54 in) length of hose with the same inner diameter as the coolant reservoir hose. Modify a one gallon bottle by making a hole at the bottom of the bottle slightly smaller than the hose outer diameter that will be covered by fluid when filled.

- Insert the hose in the bottom of the bottle.
- Seal the hose to the bottle so it will not leak.

BT

HA

SC

EL

IDX

GENERAL MAINTENANCE

General maintenance includes those items which should be checked during the normal day-to-day operation of the vehicle. They are essential if the vehicle is to continue operating properly. The owners can perform checks and inspections themselves or they can have their NISSAN dealers do them.

OUTSIDE THE VEHICLE

The maintenance items listed here should be performed from time to time, unless otherwise specified.

| Item | | Reference page |
|------------------------------------|-----------------------------------------------------------------------------------------------------------------------------------------------------------------------------------------------------------------------------------------------------------------------------------------------------------------------------------------------------------------------------------|----------------------------------------------|
| Tires | Check the pressure with a gauge periodically when at a service station, including the spare, and adjust to the specified pressure if necessary. Check carefully for damage, cuts or excessive wear. | — |
| Wheel nuts | When checking the tires, make sure no nuts are missing, and check for any loose nuts. Tighten if necessary. | — |
| Tire rotation | Tires should be rotated every 12,000 km (7,500 miles). | MA-25 |
| Wheel alignment and balance | If the vehicle pulls to either side while driving on a straight and level road, or if you detect uneven or abnormal tire wear, there may be a need for wheel alignment. If the steering wheel or seat vibrates at normal highway speeds, wheel balancing may be needed. | MA-25, SU-6 , "Front Wheel Alignment" |
| Windshield wiper blades | Check for cracks or wear if they do not wipe properly. | — |
| Doors and engine hood | Check that all doors and the engine hood operate smoothly as well as the trunk lid and back hatch. Also make sure that all latches lock securely. Lubricate if necessary. Make sure that the secondary latch keeps the hood from opening when the primary latch is released. When driving in areas using road salt or other corrosive materials, check lubrication frequently. | MA-28 |

INSIDE THE VEHICLE

The maintenance items listed here should be checked on a regular basis, such as when performing periodic maintenance, cleaning the vehicle, etc.

| Item | | Reference page |
|-----------------------------------------|---------------------------------------------------------------------------------------------------------------------------------------------------------------------------------------------------------------------------------------------------------------------------------------------------------------------------------------------------------------------------------|--------------------------------------------|
| Lamps | Make sure that the headlamps, stop lamps, tail lamps, turn signal lamps, and other lamps are all operating properly and installed securely. Also check headlamp aim. | — |
| Warning lamps and buzzers/chimes | Make sure that all warning lamps and buzzers/chimes are operating properly. | — |
| Windshield wiper and washer | Check that the wipers and washer operate properly and that the wipers do not streak. | — |
| Windshield defroster | Check that the air comes out of the defroster outlets properly and in sufficient quantity when operating the heater or air conditioning. | — |
| Steering wheel | Check that it has the specified play. Be sure to check for changes in the steering condition, such as excessive play, hard steering or strange noises. Free play: Less than 35 mm (1.38 in) | — |
| Seats | Check seat position controls such as seat adjusters, seat back recliner, etc. to make sure they operate smoothly and that all latches lock securely in every position. Check that the head restraints move up and down smoothly and that the locks (if equipped) hold securely in all latched positions. Check that the latches lock securely for folding-down rear seat backs. | — |
| Seat belts | Check that all parts of the seat belt system (e.g. buckles, anchors, adjusters and retractors) operate properly and smoothly and are installed securely. Check the belt webbing for cuts, fraying, wear or damage. | MA-28, RS-9 "Seat Belt Inspection" |
| Brakes | Check that the brakes do not pull the vehicle to one side when applied. | — |
| Accelerator pedal | Check the pedal for smooth operation and make sure the pedal does not catch or require uneven effort. Keep the floor mats away from the pedal. | FE-3 , "Accelerator control system" |

GENERAL MAINTENANCE

| Item | | Reference page | |
|---------------------------------------------|-------------------------------------------------------------------------------------------------------------------------------------------------------------------------------------------------------------------------------------------------|-----------------------------------------------------------------------------|----------|
| Brake pedal and booster | Check the pedal for smooth operation and make sure it has the proper distance under it when depressed fully. Check the brake booster function. Be sure to keep floor mats away from the pedal. | BR-13 , "Brake Pedal and Bracket" and BR-18 , "Brake Booster" | GI |
| Parking brake | Check that the lever has the proper travel and make sure that the vehicle is held securely on a fairly steep hill when only the parking brake is applied. | BR-29 , "Parking Brake Control" | MA |
| Automatic transaxle "Park" mechanism | Check that the brake pedal must be depressed for the selector lever to be moved from the "P" position. On a fairly steep hill, check that the vehicle is held securely with the selector lever in the "P" position without applying any brakes. | — | EM LC |

UNDER THE HOOD AND VEHICLE

The maintenance items listed here should be checked periodically (e.g. each time you check the engine oil or refuel).

| Item | | Reference page | |
|---------------------------------------------|------------------------------------------------------------------------------------------------------------------------------------------------------------------------------------------------------------------------------------------------------------------------------------------------------------------------------------------------------------------------------------------------------------------------------|----------------|----------|
| Windshield washer fluid | Check that there is adequate fluid in the tank. | — | FE |
| Engine coolant level | Check the coolant level when the engine is cold. | MA-14 | AT |
| Radiator and hoses | Check the front of the radiator and clean off any dirt, insects, leaves, etc., that may have accumulated. Make sure the hoses have no cracks, deformation, deterioration or loose connections. | — | AX |
| Brake fluid level | Make sure that the brake fluid level is between the "MAX" and "MIN" lines on the reservoir. | MA-25 | SU |
| Battery | Check the fluid level in each cell. It should be between the "MAX" and "MIN" lines. | — | BR |
| Engine drive belts | Make sure that no belt is frayed, worn, cracked or oily. | MA-13 | |
| Engine oil level | Check the level on the dipstick after parking the vehicle on a level spot with the engine off for at least 30 seconds. | MA-19 | ST |
| Power steering fluid level and lines | Check the level on the dipstick with the engine off. Check the lines for improper attachment, leaks, cracks, etc. | MA-27 | RS |
| Automatic transaxle fluid level | Check the level on the dipstick after putting the selector lever in "P" with the engine idling. | MA-24 | BT |
| Exhaust system | Make sure there are no loose supports, cracks or holes. If the sound of the exhaust seems unusual or there is a smell of exhaust fumes, immediately locate the trouble and correct it. | MA-24 | HA |
| Underbody | The underbody is frequently exposed to corrosive substances such as those used on icy roads or to control dust. It is very important to remove these substances, otherwise rust will form on the floor pan, frame, fuel lines and around the exhaust system. At the end of winter, the underbody should be thoroughly flushed with plain water, being careful to clean those areas where mud and dirt can easily accumulate. | — | SC EL |
| Fluid leaks | Check under the vehicle for fuel, oil, water or other fluid leaks after the vehicle has been parked for a while. Water dripping from the air conditioner after use is normal. If you should notice any leaks or gasoline fumes are evident, check for the cause and correct it immediately. | — | IDX |

PERIODIC MAINTENANCE

Two different maintenance schedules are provided, and should be used, depending upon the conditions in which the vehicle is usually operated. **After 60,000 miles (96,000 km) or 48 months, continue the periodic maintenance at the same mileage/time intervals.**

| | | | |
|------------|----------------------------------------------------------------------------------------------------------------------------------------------------------------------------------------------------------------------------------------------------------------------------------------------------------------------------------------------------------------------------------------------------------------------------------------------------------------------------------------------------------------------------------------------------------------------------------------------------------------------------------------------------------------------------------------------------------------------------------|-------------------------------------|-------|
| Schedule 1 | Follow Periodic Maintenance Schedule 1 if owner's driving habits frequently includes one or more of the following driving conditions: <ul style="list-style-type: none"> ● Repeated short trips of less than 5 miles (8 km). ● Repeated short trips of less than 10 miles (16 km) with outside temperatures remaining below freezing. ● Operating in hot weather in stop-and-go "rush hour" traffic. ● Extensive idling and/or low speed driving for long distances, such as police, taxi or door-to-door delivery use. ● Driving in dusty conditions. ● Driving on rough, muddy, or salted roads. ● Towing a trailer, using a camper or a car-top carrier. | Emission Control System Maintenance | MA-7 |
| | | Chassis and Body Maintenance | MA-8 |
| Schedule 2 | Follow Periodic Maintenance Schedule 2 if none of the driving conditions shown in Schedule 1 apply to owner's driving habits. | Emission Control System Maintenance | MA-9 |
| | | Chassis and Body Maintenance | MA-10 |

PERIODIC MAINTENANCE

Schedule 1

NDMA0004S01

NDMA0004S0102



MA

EM

LC

EC

FE

AT

AX

SU

BR

ST

RS

BT

HA

SC

EL

IDX

Schedule 1

EMISSION CONTROL SYSTEM MAINTENANCE

Abbreviations: R = Replace. I = Inspect. Correct or replace if necessary. []: At the mileage intervals only

| MAINTENANCE OPERATION | MAINTENANCE INTERVAL | | | | | | | | | | | | | | Reference Section - Page or Content Title | | |
|---------------------------------------------------------------------------------------|-----------------------------------|-------------------------------------------------------|------------|--------------|------------|---------------|--------------|---------------|------------|---------------|--------------|---------------|------------|---------------|-------------------------------------------|-----------------------------|---------------|
| | Miles x 1,000 (km x 1,000) Months | 3.75 (6) 3 | 7.5 (12) 6 | 11.25 (18) 9 | 15 (24) 12 | 18.75 (30) 15 | 22.5 (36) 18 | 26.25 (42) 21 | 30 (48) 24 | 33.75 (54) 27 | 37.5 (60) 30 | 41.25 (66) 33 | 45 (72) 36 | 48.75 (78) 39 | | 52.5 (84) 42 | 56.25 (90) 45 |
| Perform at number of miles, kilometers or months, whichever comes first. | | | | | | | | | | | | | | | | | |
| Drive belts | NOTE (1) | | | | | | | | | | | | | | | | I* |
| Air cleaner filter | NOTE (2) | | | | | | | [R] | | | | | | | | | [R] |
| EVAP vapor lines | | | | | | | | I* | | | | | | | | | I* |
| Fuel lines | | | | | | | | I* | | | | | | | | | I* |
| Fuel filter* | NOTE (3) | | | | | | | | | | | | | | | | |
| Engine coolant | | Replace every 30,000 miles (48,000 km) or 36 months.* | | | | | | | | | | | | | | MA-14 | |
| Engine oil | | R | R | R | R | R | R | R | R | R | R | R | R | R | R | R | R |
| Engine oil filter (Use part No. 15208-7B000, 15208-31U00, 15208-9E000 or equivalent.) | | R | R | R | R | R | R | R | R | R | R | R | R | R | R | R | R |
| Spark plugs (double platinum-tipped type) | | Replace every 105,000 miles (169,000 km) | | | | | | | | | | | | | | MA-20 | |
| Timing belt | | Replace every 105,000 miles (169,000 km) | | | | | | | | | | | | | | MA-21 | |
| Timing belt | | Replace every 105,000 miles (169,000 km) | | | | | | | | | | | | | | EM-17 Timing Belt | |

NOTE:

- (1) After 60,000 miles (96,000 km) or 48 months, inspect every 15,000 miles (24,000 km) or 12 months.
 - (2) If operating mainly in dust conditions, more frequent maintenance may be required.
 - (3) When the filter becomes clogged, the vehicle speed cannot be increased as the driver wishes. In such an event, replace the filter.
- ★ Maintenance items and intervals with "*" are recommended by NISSAN for reliable vehicle operation. The owner need not perform such maintenance in order to maintain the emission warranty or manufacturer recall liability. Other maintenance items and intervals are required.

PERIODIC MAINTENANCE

Schedule 1 (Cont'd)

CHASSIS AND BODY MAINTENANCE

NDMA0004S0102

Abbreviations: R = Replace. I = Inspect. Correct or replace if necessary. L = Lubricate.

| MAINTENANCE OPERATION | Miles x 1,000 (km x 1,000) Months | MAINTENANCE INTERVAL | | | | | | | | | | | | Reference Section - Page or - Content Title | | | | |
|--------------------------------------------------------------------------|-----------------------------------------|----------------------|------------------|--------------------|------------------|---------------------|--------------------|---------------------|------------------|---------------------|--------------------|---------------------|------------------|---------------------------------------------------------|---------------------|--------------------|---------------------|------------------|
| | | 3.75 (6) 3 | 7.5 (12) 6 | 11.25 (18) 9 | 15 (24) 12 | 18.75 (30) 15 | 22.5 (36) 18 | 26.25 (42) 21 | 30 (48) 24 | 33.75 (54) 27 | 37.5 (60) 30 | 41.25 (66) 33 | 45 (72) 36 | | 48.75 (78) 39 | 52.5 (84) 42 | 56.25 (90) 45 | 60 (96) 48 |
| Perform at number of miles, kilometers or months, whichever comes first. | | | | | | | | | | | | | | | | | | |
| Brake lines & cables | | | | | I | | | | | | | | | | | | | I |
| Brake pads, rotors, drums & linings | | | I | | I | | | | | | | | | | | | | I |
| Automatic transaxle fluid | NOTE (1) | | | | I | | | | | | | | | | | | | I |
| Cabin air filter | NOTE (5) | | | | R | | | | | | | | | | | | | R |
| Steering gear, linkage, axle & suspension parts | NOTE (4) | | I | | I | | | | | | | | | | | | | I |
| Tire rotation | NOTE (2) | | | | | | | | | | | | | | | | | |
| Drive shaft boots | | | I | | I | | | | | | | | | | | | | I |
| Exhaust system | | | I | | I | | | | | | | | | | | | | I |
| Supplemental air bag system | NOTE (3) | | | | | | | | | | | | | | | | | |
| ASCD vacuum hoses | | | | | I | | | | | | | | | | | | | I |

NOTE:

- (1) If towing a trailer, using a camper or a car-top carrier, or driving on rough or muddy roads, change (not just inspect) oil at every 30,000 miles (48,000 km) or 24 months.
- (2) Refer to "Tire Rotation" under the "GENERAL MAINTENANCE" heading earlier in this section.
- (3) Inspect the air bag system 10 years after the date of manufacture noted on the FMVSS certification label.
- (4) Refer to "Front Suspension Parts", **SU-5**, "Rear Suspension Parts", **SU-16**, "Front Axle Parts", **AX-3** and "Rear Axle Parts", **AX-18**.
- (5) If operating mainly in dusty conditions more frequent maintenance may be required.

PERIODIC MAINTENANCE

Schedule 2

NDMA0004S02

NDMA0004S0201



MA

EM

LC

EC

FE

AT

AX

SU

BR

ST

RS

BT

HA

SC

EL

IDX

Schedule 2

EMISSION CONTROL SYSTEM MAINTENANCE

Abbreviations: R = Replace. I = Inspect. Correct or replace if necessary. []: At the mileage intervals only

| MAINTENANCE OPERATION | MAINTENANCE INTERVAL | | | | | | | | | | Reference Section - Page or - Content Title | | |
|---------------------------------------------------------------------------------------|-----------------------------------------|-------------------------------------------------------|------------------|--------------------|------------------|--------------------|------------------|--------------------|------------------|---|------------------------------------------------------|-----------------------------|-------|
| | Miles x 1,000 (km x 1,000) Months | 7.5 (12) 6 | 15 (24) 12 | 22.5 (36) 18 | 30 (48) 24 | 37.5 (60) 30 | 45 (72) 36 | 52.5 (84) 42 | 60 (96) 48 | | | | |
| Perform at number of miles, kilometers or months, whichever comes first. | | | | | | | | | | | | | |
| Drive belts | NOTE (1) | | | | | | | | | | I* | MA-13 | |
| Air cleaner filter | | | | | [R] | | | | | | [R] | MA-19 | |
| EVAP vapor lines | | | | | I* | | | | | | I* | MA-23 | |
| Fuel lines | | | | | I* | | | | | | I* | MA-18 | |
| Fuel filter* | NOTE (2) | | | | | | | | | | | MA-18 | |
| Engine coolant | | Replace every 30,000 miles (48,000 km) or 36 months.* | | | | | | | | | | MA-14 | |
| Engine oil | | R | R | R | R | R | R | R | R | R | R | | MA-19 |
| Engine oil filter (Use part No. 15208-7B000, 15208-31U00, 15208-9E000 or equivalent.) | | R | R | R | R | R | R | R | R | R | R | | MA-20 |
| Spark plugs (double platinum-tipped type) | | Replace every 105,000 miles (169,000 km) | | | | | | | | | | MA-21 | |
| Timing belt | | Replace every 105,000 miles (169,000 km) | | | | | | | | | | EM-17 Timing Belt | |

NOTE:

(1) After 60,000 miles (96,000 km) or 48 months, inspect every 15,000 miles (24,000 km) or 12 months.

(2) When the filter becomes clogged, the vehicle speed cannot be increased as the driver wishes. In such an event, replace the filter.

★ Maintenance items and intervals with "*" are recommended by NISSAN for reliable vehicle operation. The owner need not perform such maintenance in order to maintain the emission warranty or manufacturer recall liability. Other maintenance items and intervals are required.

PERIODIC MAINTENANCE

Schedule 2 (Cont'd)

CHASSIS AND BODY MAINTENANCE

NDMA0004S0202

Abbreviations: R = Replace. I = Inspect. Correct or replace if necessary. L = Lubricate.

| MAINTENANCE OPERATION | Miles x 1,000 (km x 1,000) Months | MAINTENANCE INTERVAL | | | | | | | | Reference Section - Page or - Content Title | |
|--------------------------------------------------------------------------|-----------------------------------------|----------------------|------------------|--------------------|------------------|--------------------|------------------|--------------------|------------------|------------------------------------------------------|-------------------------------|
| | | 7.5 (12) 6 | 15 (24) 12 | 22.5 (36) 18 | 30 (48) 24 | 37.5 (60) 30 | 45 (72) 36 | 52.5 (84) 42 | 60 (96) 48 | | |
| Perform at number of miles, kilometers or months, whichever comes first. | | | | | | | | | | | |
| Brake lines & cables | | | I | | I | | | | I | | MA-26 |
| Brake pads, rotors, drums & linings | | | I | | I | | | | I | | MA-26, 26 |
| Automatic transaxle fluid | | | I | | I | | | | I | | MA-24 |
| Cabin air filter | NOTE (4) | | R | | | | R | | | R | HA-139 Cabin air filter |
| Steering gear, linkage, axle & suspension parts | NOTE (3) | | | | | | I | | | I | MA-27 NOTE (3) |
| Tire rotation | NOTE (1) | | | | | | | | | | MA-4 |
| Drive shaft boots | | | I | | | | | | | I | AX-13 Drive Shaft |
| Exhaust system | | | | | | | I | | | I | MA-24 |
| Supplemental air bag system | NOTE (2) | | | | | | | | | | RS-3 Maintenance Item |
| ASCD vacuum hoses | | | I | | | | | | | I | EL-233 ASCD Actuator Check |

NOTE:

- (1) Refer to "Tire Rotation" under the "GENERAL MAINTENANCE" heading earlier in this section.
- (2) Inspect the air bag system 10 years after the date of manufacture noted on the FMVSS certification label.
- (3) Refer to "Front Suspension Parts", **SU-5**, "Rear Suspension Parts", **SU-16**, "Front Axle Parts", **AX-3**, and "Rear Axle Parts", **AX-18**.
- (4) If operating mainly in dusty conditions more frequent maintenance may be required.

RECOMMENDED FLUIDS AND LUBRICANTS

Fluids and Lubricants

Fluids and Lubricants

NDMA0005S01

| | | | Capacity (Approximate) | | | Recommended Fluids/Lubricants |
|---------------------------------|-----------------------------------|-------------|------------------------|------------------|----------|--------------------------------------------------------------------------------------------------------------------------------------------------------------------------------------------------------------------------------|
| | | | US mea- sure | Imp mea- sure | Liter | |
| Engine oil drain and refill | With oil filter | | 4 qt | 3-3/8 qt | 3.8 | <ul style="list-style-type: none"> ● API Certification Mark*1 ● API grade SG/SH, energy Con- serving I & II or API grade SJ, Energy Conserving*1 ● ILSAC grade GF-I & GF-II*1 |
| | Without oil filter | | 3-7/8 qt | 3-1/8 qt | 3.6 | |
| | Dry engine (engine over- haul) | | 4-1/2 qt | 3-3/4 qt | 4.3 | |
| Cooling system (With reservoir) | | | 11-1/4 qt | 9-3/8 qt | 10.6 | 50% Genuine NISSAN Anti-freeze Coolant or equivalent 50% demineralized water or distilled water |
| Automatic transaxle fluid | | | 10 qt | 8-1/4 qt | 9.4 | NISSAN MATIC "D" (Continental U.S. and Alaska) or Canada NISSAN Automatic Transmission Fluid*3 |
| Power steering fluid | | | 1-1/8 qt | 1 qt | 1.1 | Type F Automatic Transmission Fluid |
| Brake fluid | | | — | — | — | Genuine NISSAN Brake Fluid*2 or equivalent DOT 3 (US FMVSS No. 116) |
| Multi-purpose grease | | | — | — | — | NLGI No. 2 (Lithium soap base) |
| Air conditioning system | With rear A/C | Lubricant | 11.0 oz | 11.5 oz | 325 ml | NISSAN A/C System Lubricant PAG Type F or equivalent*4 |
| | | Refrigerant | 3.376 lb | — | 1.531 kg | R-134a |
| | Front A/C only | Lubricant | 7.0 oz | 7.3 oz | 207 ml | NISSAN A/C System Lubricant PAG Type F or equivalent*4 |
| | | Refrigerant | 2.0 lb | — | 0.907 kg | R-134a |

*1: For further details, see "SAE Viscosity Number".

*2: Available in mainland U.S.A. through your NISSAN dealer.

*3: DEXRON™ III/MERCON™ or equivalent may also be used. Outside the continental United States and Alaska contact a NISSAN dealership for more information regarding suitable fluids, including recommended brand(s) of DEXRON™ III/MERCON™ Automatic Transmission Fluid.

*4: Suniso 5GS is not acceptable for use in this vehicle.

GI

MA

EM

LC

EC

FE

AT

AX

SU

BR

ST

RS

BT

HA

SC

EL

IDX

RECOMMENDED FLUIDS AND LUBRICANTS

SAE Viscosity Number

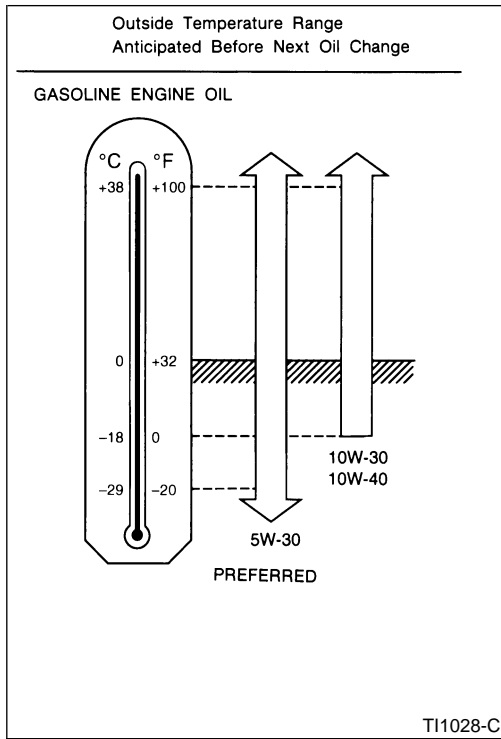

SAE Viscosity Number

NDMA0005S02

GASOLINE ENGINE OIL

NDMA0005S0201

SAE 5W-30 viscosity oil is preferred for all temperatures. SAE 10W-30 and 10W-40 viscosity oil may be used if the ambient temperature is above -18°C (0°F).

Anti-freeze Coolant Mixture Ratio

NDMA0005S03

The engine cooling system is filled at the factory with a high-quality, year-round, anti-freeze coolant solution. The anti-freeze solution contains rust and corrosion inhibitors. Therefore, additional cooling system additives are not necessary.

CAUTION:

When adding or replacing coolant, be sure to use only a Genuine Nissan Anti-freeze Coolant or equivalent with the proper mixture ratio.

| Outside temperature down to | | Genuine NISSAN Anti-freeze Coolant or equivalent | Demineralized water or distilled water |
|-----------------------------|--------------------|--------------------------------------------------------|----------------------------------------------|
| $^{\circ}\text{C}$ | $^{\circ}\text{F}$ | | |
| -35 | -30 | 50% | 50% |

The use of other types of coolant solutions may damage the engine cooling system.

Checking Drive Belts

NDMA0006S01

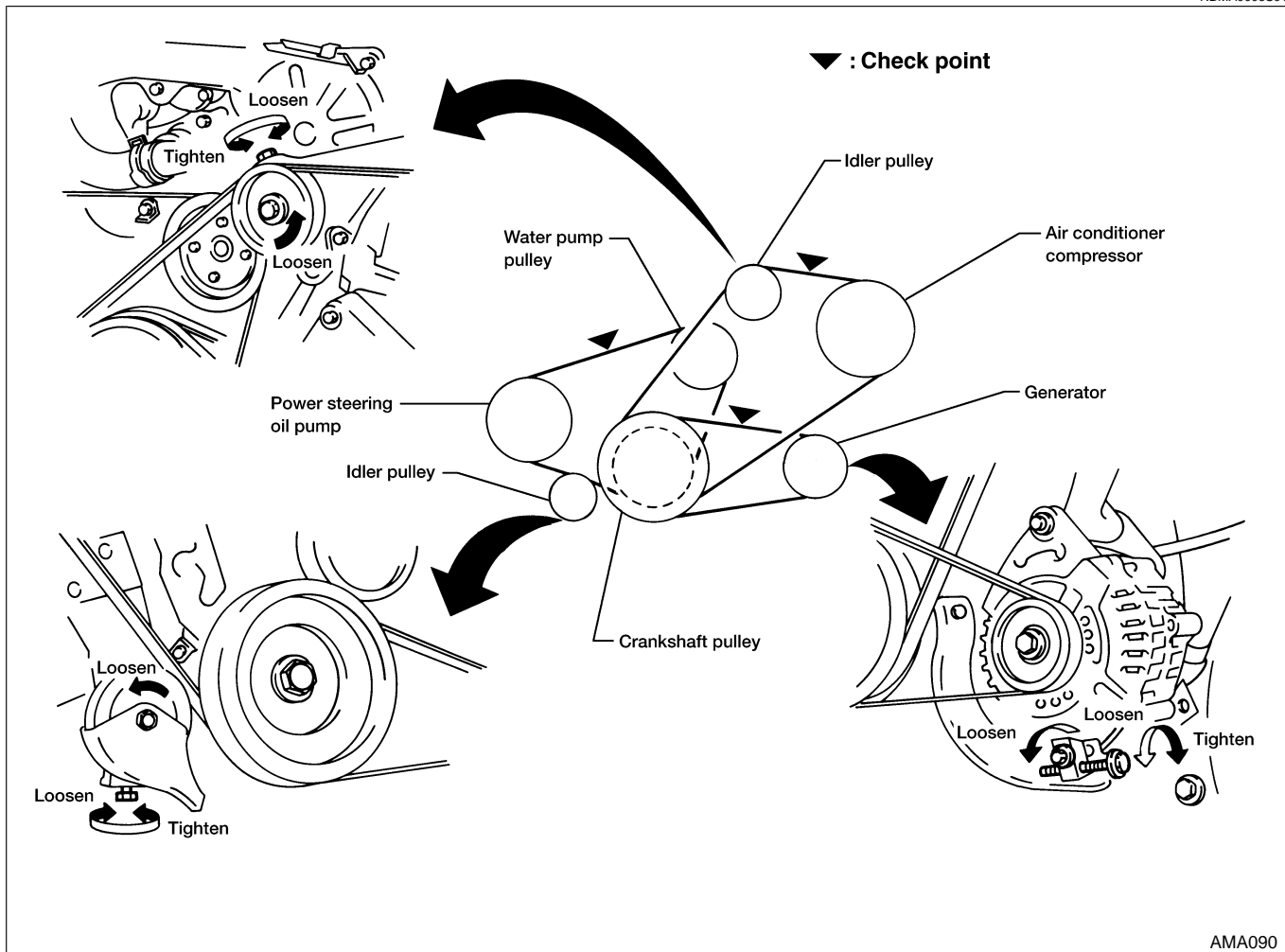

1. Inspect belt for cracks, fraying, wear and oil. If necessary, replace.
2. Inspect drive belt deflection or tension at a point on the belt midway between pulleys.
3. Check belt tension using belt tension gauge (BT3373-F or equivalent).

Inspect drive belt deflection or tension when engine is cold. Adjust if belt deflections exceed the limit or if belt tension is not within specifications.

Drive belt tension can be checked at other points on the belt.

GI

MA

EM

LC

EC

FE

AT

AX

SU

BR

ST

RS

BT

HA

SC

EL

IDX

ENGINE MAINTENANCE

Checking Drive Belts (Cont'd)

Belt deflection and tension

| | Deflection adjustment | | Unit: mm (in) | Tension adjustment*1 | | Unit :N (kg, lb) |
|----------------------------|-----------------------|---------------------------|---------------------------|----------------------|----------------------------------------|----------------------------------------|
| | Used belt | | New belt | Used belt | | New belt |
| | Limit | After adjustment | | Limit | After adjustment | |
| Generator | 12 (0.47) | 7.5 - 8.5 (0.295 - 0.335) | 6.5 - 7.5 (0.256 - 0.295) | 225 (23, 51) | 554 - 642 (56.5 - 65.5, 124.6 - 144.4) | 671 - 759 (68.5 - 77.5, 151.0 - 170.9) |
| Air conditioner compressor | 10 (0.39) | 5 - 7 (0.20 - 0.28) | 4 - 6 (0.16 - 0.24) | 196 (20, 44) | 495 - 583 (50.5 - 59.5, 111.4 - 131.2) | 603 - 691 (61.5 - 70.5, 135.6 - 155.5) |
| Power steering oil pump | 16 (0.63) | 10 - 12 (0.39 - 0.47) | 8 - 10 (0.31 - 0.39) | 196 (20, 44) | 495 - 583 (50.5 - 59.5, 111.4 - 131.2) | 603 - 691 (61.5 - 70.5, 135.6 - 155.5) |
| Applied pushing force | 98 N (10 kg, 22 lb) | | | — | | |

*1 If belt tension gauge cannot be installed at check points shown, check drive belt tension at a different location on the belt.

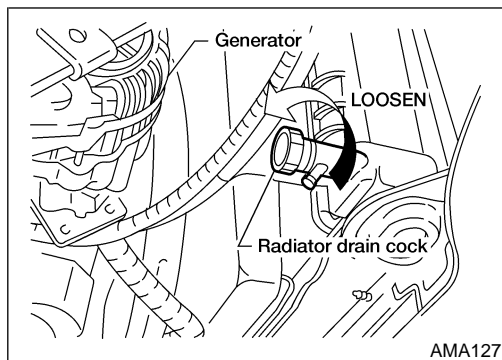

Changing Engine Coolant

NDMA0006S02

WARNING:

- To avoid the danger of being scalded, never change the coolant when the engine is hot.
- Wrap a thick cloth around radiator cap and carefully remove the cap. At first, turn the cap a quarter of a turn to release built up pressure. Then turn the cap all the way.

NOTE:

Refer to "Preparation for Changing Engine Coolant", MA-3.

—DRAINING ENGINE COOLANT—

1. Open the radiator drain at bottom of radiator and remove radiator filler cap.
 2. Remove reservoir tank, drain coolant, then clean reservoir tank. Install it temporarily.
- Be careful not to allow coolant to contact drive belts.

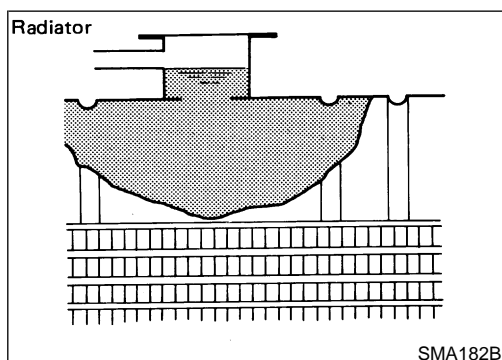
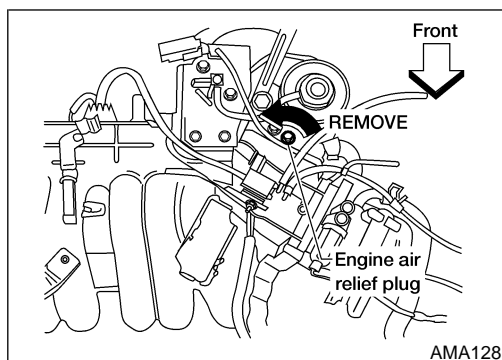
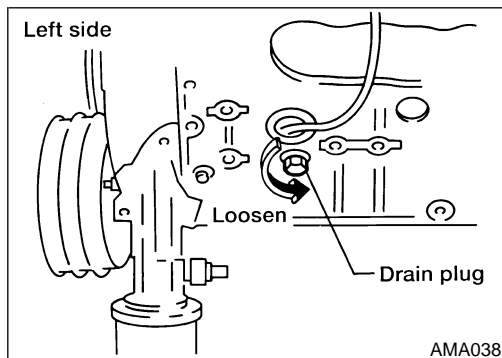
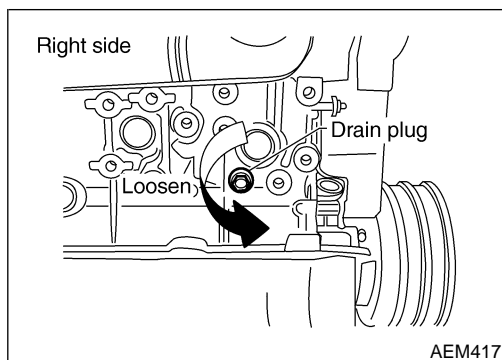

- Open drain plugs on both sides of cylinder block.

- Remove engine air relief plug.
- Check drained coolant for contaminants such as rust corrosion or discoloration.
If contaminated, flush engine cooling system.
Refer to "FLUSHING COOLING SYSTEM", MA-18.

—REFILLING ENGINE COOLANT—

- Install reservoir tank, radiator drain plug, and cylinder block drain plugs.
 - Apply sealant to the thread of cylinder block drain plug.
⚙️ : 34 - 44 N-m (3.5 - 4.5 kg-m, 25 - 33 ft-lb)
- Slowly fill radiator with proper mixture of coolant at speed of less than 3 ℓ (3-1/8 US qt, 2-5/8 Imp qt)/min.
Pour coolant through filler neck slowly to allow air in system to escape. Fill until coolant fills the radiator neck.
 - Use Genuine NISSAN Anti-freeze coolant or equivalent mixed with demineralized water or distilled water. Refer to "RECOMMENDED FLUIDS AND LUBRICANTS", MA-11.
Coolant capacity (without reservoir tank):
9.5 ℓ (10 US qt, 8-3/8 Imp qt)
Reservoir tank capacity (for MAX level):
1.1 ℓ (1-1/8 US qt, 1 Imp qt)
- Pour more coolant into radiator while gently squeezing upper radiator hose.
 - Slowly fill radiator until coolant level no longer lowers in filler neck.

GI

MA

EM

LC

EC

FE

AT

AX

SU

BR

ST

RS

BT

HA

SC

EL

IDX

ENGINE MAINTENANCE

Changing Engine Coolant (Cont'd)

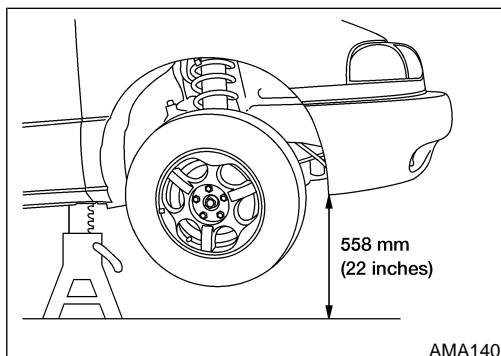
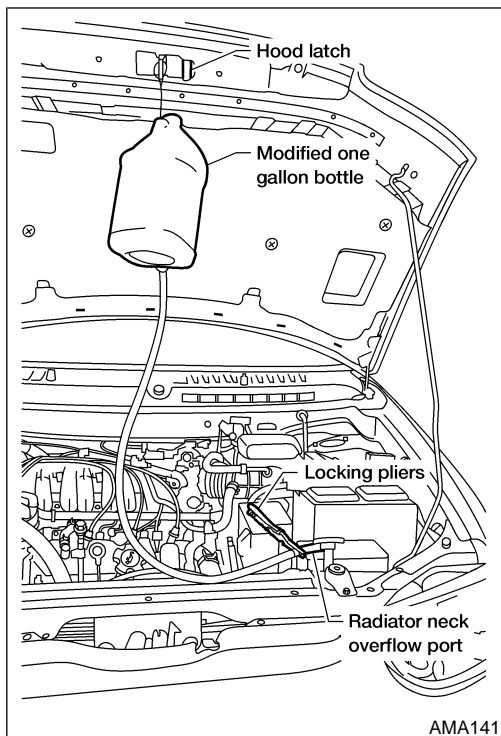
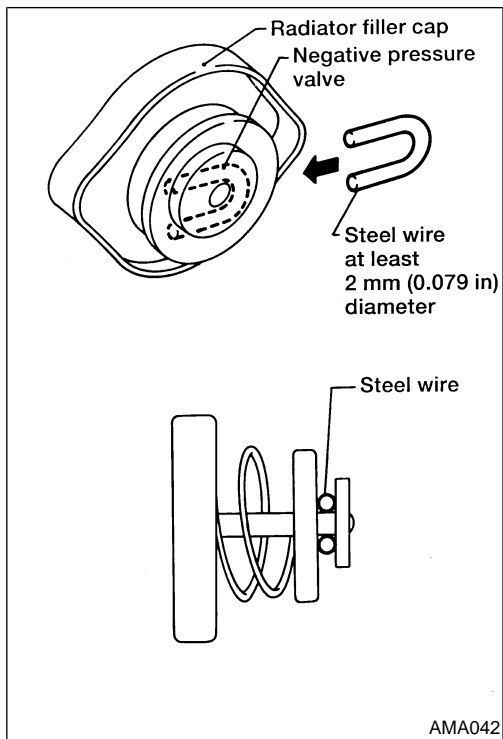

9. Install a wire under radiator filler cap negative pressure valve to allow flow of air and coolant regardless of pressure.
10. Install radiator cap.
11. Disconnect the coolant reservoir hose from the radiator neck overflow port.

12. Attach the hose from the modified one gallon bottle to the radiator neck overflow port. Refer to "Preparation for Changing Engine Coolant", MA-3.
13. Using locking pliers, clamp off the hose from the modified one gallon bottle.
14. Fill the modified one gallon bottle with the proper mixture of coolant and hang the bottle from the hood striker assembly.
15. Remove the locking pliers from the coolant hose to the modified one gallon bottle and allow the coolant to flow until coolant comes out of the engine air relief hole.
16. Using the locking pliers, reclamp the coolant hose from the modified one gallon bottle.
17. Install and tighten the engine air relief plug.

Air relief plug:

20–26 N·m (2.0–2.7 kg·m, 14–20 ft·lb)

18. Raise the front of the vehicle so that the bottom of the front fascia is 558 mm (22 inches) from the ground.

CAUTION:

Fix rear tires with tire stopper. Support front garage jack point and put safety stands to front safety stand points.

GI

MA

EM

LC

EC

FE

AT

AX

SU

BR

ST

RS

BT

HA

SC

EL

IDX

Front A/C control unit

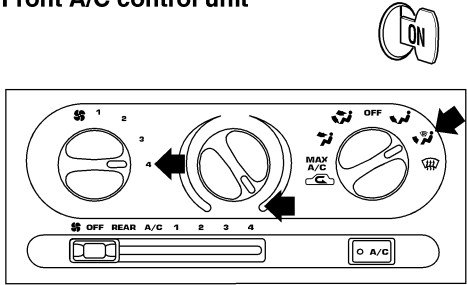

WMA004

EATC control unit

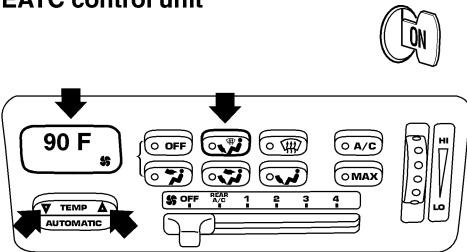

WMA005

Manual air conditioner models

Set the heater controls to full warm and the fan speed to high.

Automatic air conditioner models

Set the heater controls temperature to 90°F and fan speed to high.

19. Remove the locking pliers from the coolant hose to the modified one gallon bottle.
20. Start the engine and maintain 1500 RPM until the cooling fan turns on (approximately 20–25 minutes).
21. Turn off the engine.
22. Let engine cool until the radiator cap can be removed safely.
23. Lower the front of the vehicle to ground level.
24. Using the locking pliers, reclamp the coolant hose from the modified one gallon bottle.
25. Remove the radiator cap.
26. Remove the modified one gallon bottle and coolant hose from the radiator neck overflow port.
27. Install the coolant reservoir hose to the radiator neck overflow port.

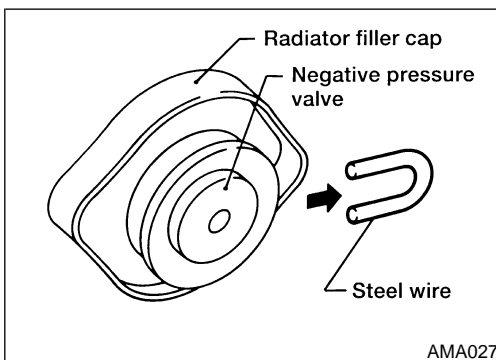

AMA027

28. Remove the wire from the radiator cap.
29. Completely fill radiator until coolant level no longer lowers in filler neck.
30. Install the radiator cap.

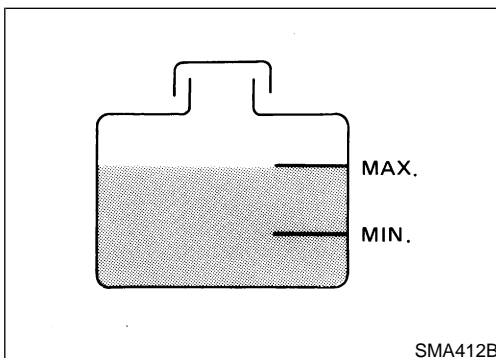

SMA412B

31. Fill coolant reservoir bottle to MAX level.
32. Reinstall coolant reservoir cap.
33. Clean excess coolant from engine block.
34. Check cooling system for leaks with engine running.

ENGINE MAINTENANCE

Flushing Cooling System

NDMA0006S0201

1. Fill radiator with water until water spills from the radiator air relief hole then close air relief plug. Fill radiator and reservoir tank with water and reinstall radiator cap.
2. Run engine and warm it up sufficiently (until lower radiator hose becomes warm).
3. Rev engine 2 or 3 times under no-load.
4. Stop engine and wait until it cools down (cool down with a fan to reduce time).
5. Drain water.
6. Repeat steps 1 through 5 until clear water begins to drain from radiator.

Coolant capacity (without reservoir tank):

9.5 ℓ (10 US qt, 8-3/8 Imp qt)

Reservoir tank capacity (for MAX level):

1.1 ℓ (1-1/8 US qt, 1 Imp qt)

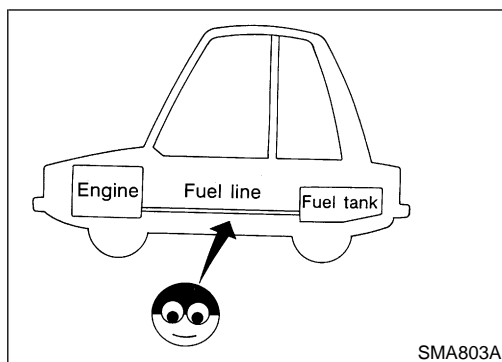

Checking Fuel Lines

NDMA0006S03

Inspect fuel lines and tank for improper attachment, leaks, cracks, damage, loose connections, chafing or deterioration. If necessary, repair or replace faulty parts.

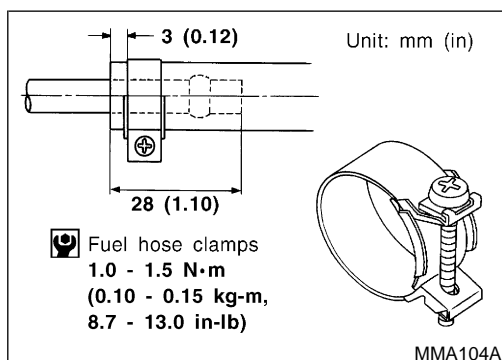

CAUTION:

Tighten high-pressure rubber hose clamp so that clamp end is 3 mm (0.12 in) from hose end.

Tightening torque specifications are the same for all rubber hose clamps.

Ensure that screw does not contact adjacent parts.

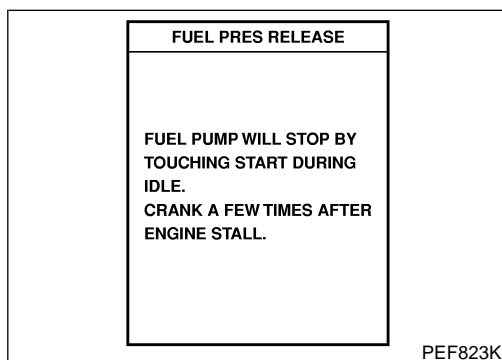

Changing Fuel Filter

NDMA0006S04

WARNING:

Before removing fuel filter, release fuel pressure from fuel line.

WITH CONSULT-II

NDMA0006S0401

1. Start engine.
2. Perform "FUEL PRES RELEASE" in "WORK SUPPORT" mode to release fuel pressure to zero.
3. After engine stalls, crank engine two or three times to make sure that fuel pressure is released.
4. Turn ignition switch OFF.

ENGINE MAINTENANCE

Changing Fuel Filter (Cont'd)

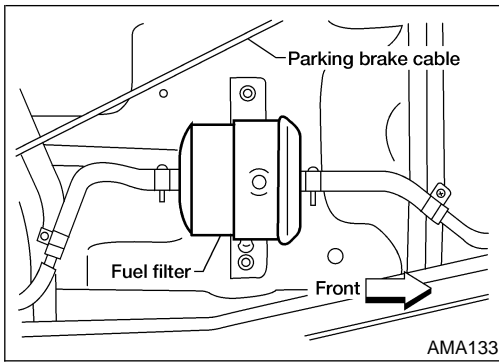

5. Loosen fuel hose clamps.
 6. Replace fuel filter.
- **Be careful not to spill fuel over engine compartment. Place a shop towel to absorb fuel.**
 - **Use a high-pressure type fuel filter. Do not use a synthetic resinous fuel filter.**
 - **When tightening fuel hose clamps, refer to “Checking Fuel Lines”, MA-18.**

GI

MA

EM

LC

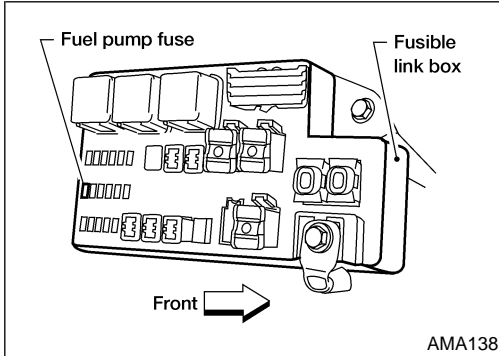

⊗ WITHOUT CONSULT-II

NDMA0006S0402

1. Remove fuel pump fuse.
2. Start engine.
3. After engine stalls, crank engine two or three times to make sure that fuel pressure is released.
4. Turn ignition switch OFF and install fuel pump fuse.

EC

FE

AT

AX

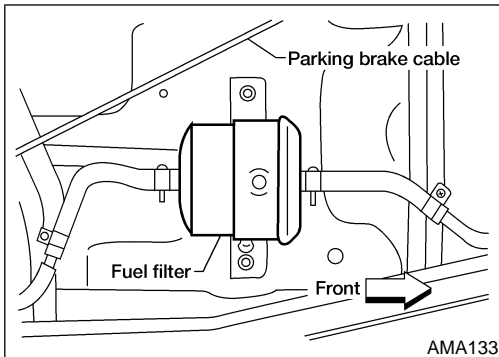

5. Loosen fuel hose clamps.
6. Replace fuel filter.

- **Be careful not to spill fuel over engine compartment. Place a shop towel to absorb fuel.**
- **Use a high-pressure type fuel filter. Do not use a synthetic resinous fuel filter.**
- **When tightening fuel hose clamps, refer to “Checking Fuel Lines”, MA-18.**

SU

BR

ST

RS

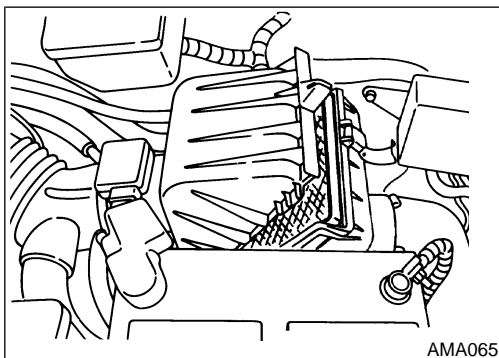

Changing Air Cleaner Filter

NDMA0006S05

VISCOUS PAPER TYPE

NDMA0006S0501

The viscous paper type filter does not need cleaning between replacement intervals.

BT

HA

SC

EL

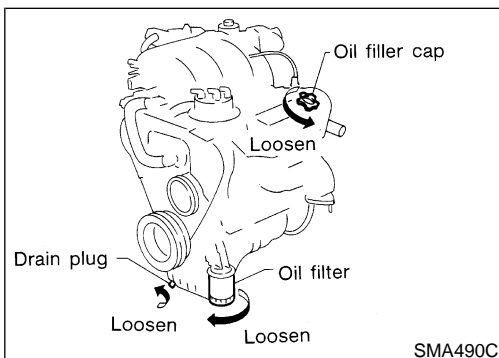

Changing Engine Oil

NDMA0006S06

WARNING:

- **Be careful not to burn yourself, as the engine oil is hot.**
 - **Prolonged and repeated contact with used engine oil may cause skin cancer; try to avoid direct skin contact with used oil. If skin contact is made, wash thoroughly with soap or hand cleaner as soon as possible.**
1. Warm up engine, and check for oil leakage from engine components.
 2. Stop engine.
 3. Remove drain plug and oil filler cap.

IDX

ENGINE MAINTENANCE

Changing Engine Oil (Cont'd)

4. Drain oil and refill with new engine oil.

Oil specification and viscosity

- API Certification Mark
- API grade SG/SH Energy Conserving I & II or API grade SJ, Energy Conserving
- ILSAC grade GF-I & GF-II
- See "RECOMMENDED FLUIDS AND LUBRICANTS," MA-11.

Oil capacity (Approximately) :

Unit: ℓ (US qt, Imp qt)

| | |
|------------------------------|--------------------|
| Drain and refill | |
| With oil filter change | 3.8 (4, 3-3/8) |
| Without oil filter change | 3.6 (3-7/8, 3-1/8) |
| Dry engine (engine overhaul) | 4.3 (4-1/2, 3-3/4) |

CAUTION:

- Be sure to clean drain plug and install with new washer.
Oil pan drain plug:
 : 29 - 39 N·m (3.0 - 4.0 kg-m, 22 - 29 ft-lb)
- The refill capacity depends on the oil temperature and drain time; use these specifications for reference only. Always use the dipstick to determine when the proper amount of oil is in the engine.

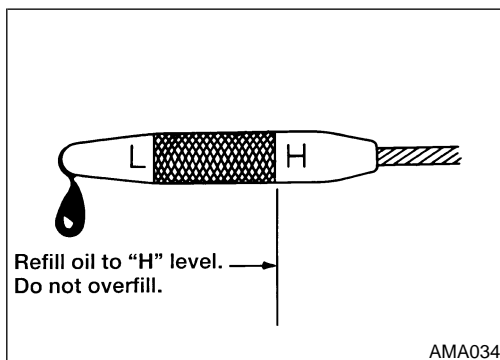

5. Warm up engine and check area around drain plug and oil filter for oil leakage.
6. Stop engine.
7. Check oil level.

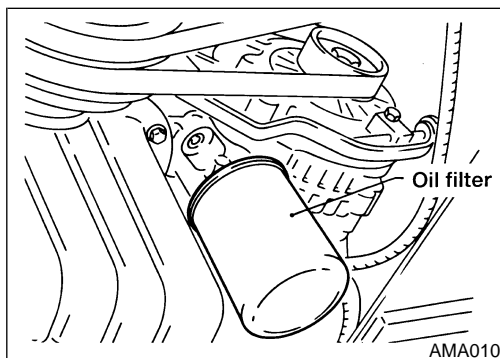

Changing Oil Filter

NDMA0006S07

1. Remove oil filter with Tool.

WARNING:

Be careful not to burn yourself, as the engine and engine oil are hot.

The filter is a full-flow cartridge type and is provided with a relief valve.

Refer to LC-6, "Oil Filter".

ENGINE MAINTENANCE

Changing Oil Filter (Cont'd)

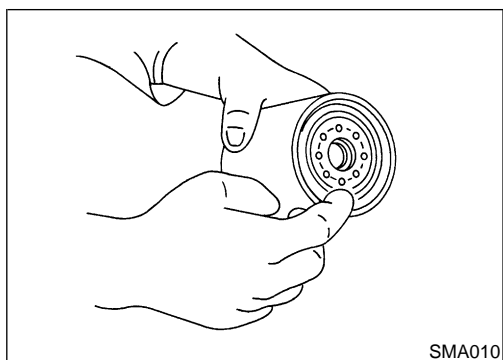

2. Clean oil filter mounting surface on cylinder block. Coat rubber seal of new oil filter with engine oil.

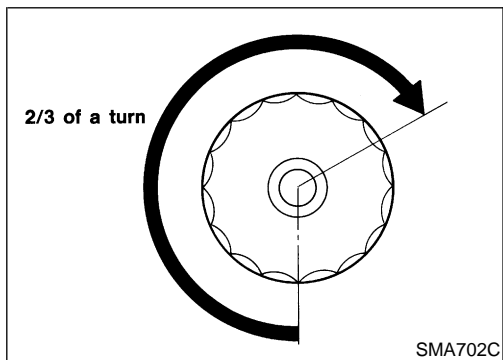

3. Screw in the oil filter until a slight resistance is felt, then tighten an additional 2/3 turn.
4. Add engine oil.

Refer to "Changing Engine Oil", MA-19.

- Clean excess oil from engine.

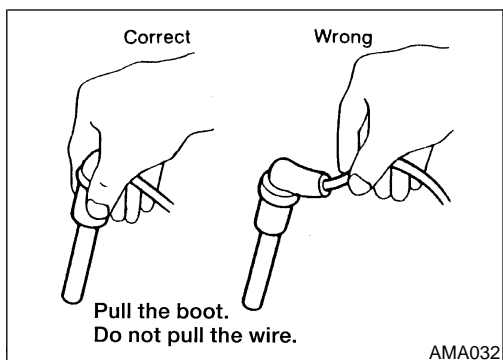

Changing Spark Plugs

1. Disconnect ignition wires from spark plugs at boot. Do not pull on the wire. NDMA0006S08

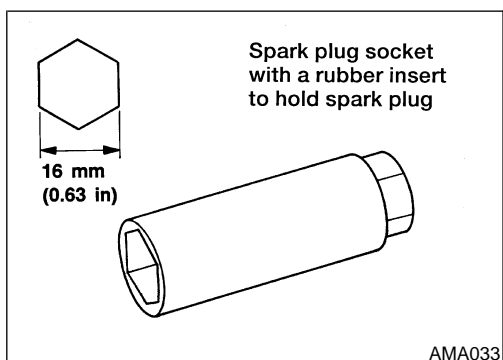

2. Remove spark plugs with a spark plug socket.

Spark plug (double platinum-tipped type):

| | |
|---------------|----------|
| Make | NGK |
| Standard type | PFR5G-11 |
| Cold type | PFR6G-11 |
| Hot type | PFR4G-11 |

Spark plug gap (nominal): 1.1 mm (0.043 in)

Use standard type spark plug for normal condition.

The hot type spark plug is suitable when fouling may occur with the standard type spark plug such as:

MA-21

GI

MA

EM

LC

EC

FE

AT

AX

SU

BR

ST

RS

BT

HA

SC

EL

IDX

ENGINE MAINTENANCE

Changing Spark Plugs (Cont'd)

- frequent engine starts
- low ambient temperatures

The cold type spark plug is suitable when spark knock may occur with the standard type spark plug such as:

- extended highway driving
- frequent high engine revolution

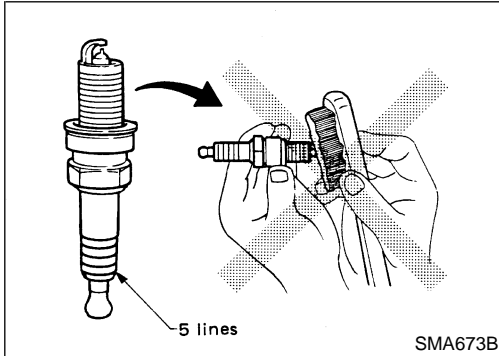

- Do not use a wire brush for cleaning.
- If plug tip is covered with carbon, spark plug cleaner may be used.

Cleaner air pressure:

Less than 588 kPa (6 kg/cm², 85 psi)

Cleaning time:

Less than 20 seconds

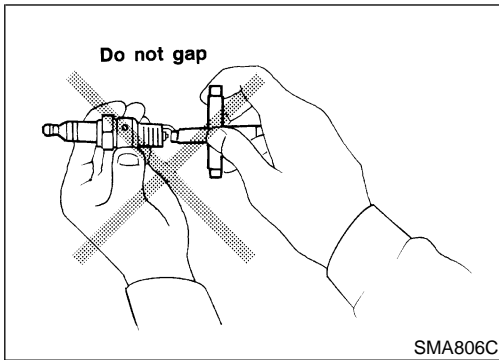

- Checking and adjusting plug gap is not required between change intervals.

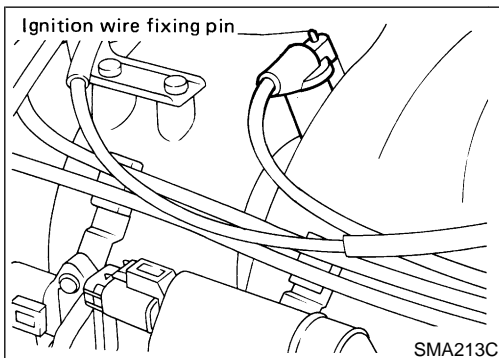

3. When installing spark plugs wires to No. 2 and 4 cylinders, securely fit each ignition wire mounting hole onto the ignition wire fixing pin.

Spark plug:

 : 20 - 29 N·m (2.0 - 3.0 kg-m, 14 - 22 ft-lb)

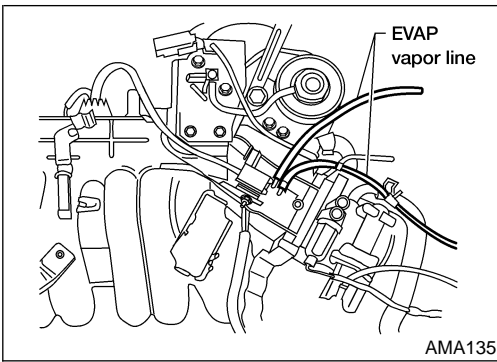

Checking EVAP Vapor Lines

NDMA0006S09

1. Visually inspect EVAP vapor lines for improper attachment, cracks, damage, loose connections, chafing or deterioration.
2. Inspect vacuum relief valve of fuel tank filler cap for clogging, sticking, etc.

Refer to **EC-28**, "EVAPORATIVE EMISSION SYSTEM".

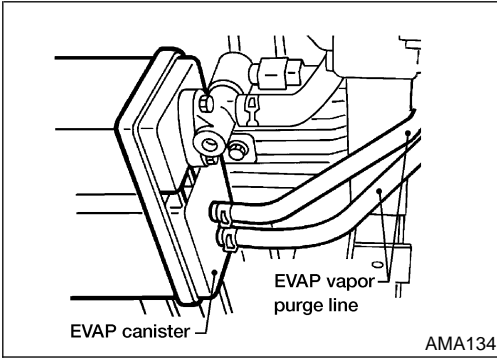

GI

MA

EM

LC

EC

FE

AT

AX

SU

BR

ST

RS

BT

HA

SC

EL

IDX

CHASSIS AND BODY MAINTENANCE

Checking Exhaust System

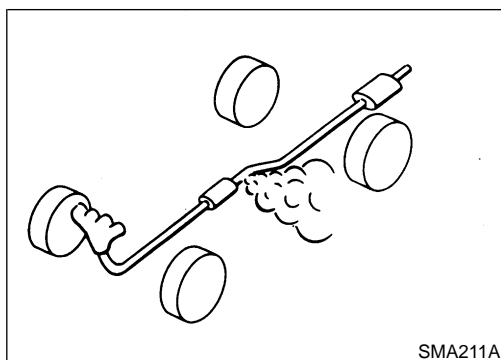

SMA211A

Checking Exhaust System

Check exhaust pipes, muffler and mounting for improper attachment, leaks, cracks, damage, loose connections, chafing or deterioration.

NDMA0007S01

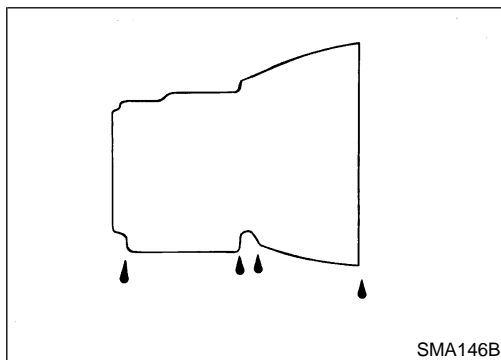

SMA146B

Checking A/T Fluid

NDMA0007S06

1. Warm up engine.
2. Check for fluid leakage.
3. Before driving, fluid level can be checked at fluid temperatures of 21 to 35°C (70 to 95°F) using "COLD" range on dipstick. However, fluid level must be rechecked using hot range.
 - a. Park vehicle on level surface and set parking brake.
 - b. Start engine and move selector lever through each gear position. Return selector lever to PARK position.
 - c. Check fluid level with engine idling.
 - d. Remove dipstick and wipe clean with lint-free paper.
 - e. Reinsert dipstick as far as it will go into charging pipe.
 - f. Remove dipstick and note reading. If reading is at low side, add fluid to the charging pipe.

Do not overfill.

| DATA MONITOR | |
|---------------|----------|
| MONITORING | |
| VHCL/S SE-A/T | XXX km/h |
| VHCL/S SE-MTR | XXX km/h |
| THRTL POS SEN | XXX V |
| FLUID TEMP SE | XXX V |
| BATTERY VOLT | XXX V |

WMA007

4. Drive vehicle for approximately 5 minutes in urban areas.
5. Determine A/T fluid temperature using CONSULT-II.



Check fluid for contamination.

SMA853B

6. Check fluid condition.
 - If fluid is very dark or smells burned, refer to "Trouble Diagnosis—Basic Inspection", **AT-61**, for checking operation of A/T. Flush cooling system after repair of A/T.
 - If A/T fluid contains frictional material (clutches, bands, etc.), replace radiator and flush cooler line using cleaning solvent and compressed air after repair of A/T. Refer to **LC-12**, "Radiator".

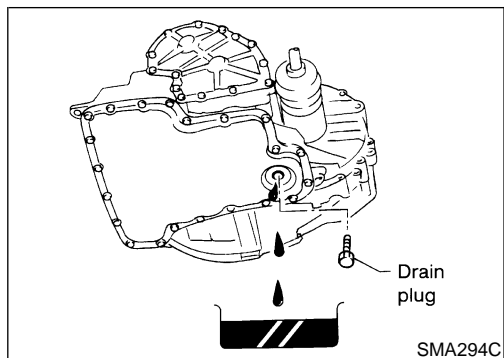

Changing A/T Fluid

NDMA0007S07

1. Warm up A/T fluid.
2. Stop engine.
3. Drain A/T fluid from drain plug and refill with new A/T fluid. Measure amount of fluid drained and refill with equal amount of new fluid.

Fluid grade:

NISSAN Matic "D" (Continental U.S. and Alaska) or Canada NISSAN Automatic Transmission Fluid. Refer to "RECOMMENDED FLUIDS AND LUBRICANTS", MA-11.

Fluid capacity (With torque converter):

9.4 l (10 US qt, 8-1/4 Imp qt)

Drain plug:

⌚ : 29 - 39 N·m (3.0 - 4.0 kg·m, 22 - 29 ft·lb)

4. Run engine at idle speed for 5 minutes.
5. Check fluid level and condition. Refer to "Checking A/T Fluid", MA-24. If fluid is still dirty, repeat steps 2 through 5.

Balancing Wheels

NDMA0007S14

Adjust wheel balance using the road wheel center.

Wheel balance (Maximum allowable unbalance):

Refer to "WHEEL BALANCE", MA-29.

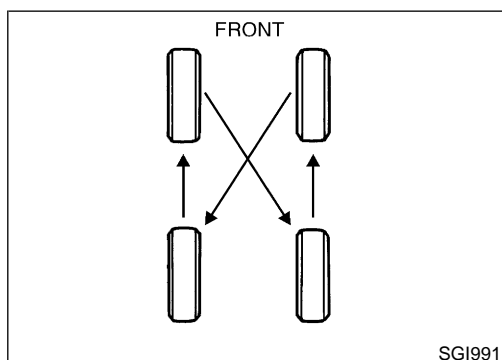

SGI991

Tire Rotation

NDMA0007S15

- After rotating the tires, adjust the tire pressure.
- Retighten the wheel nuts when the vehicle has been driven for 600 miles (1,000 km) (also in cases of a flat tire, etc.).

Wheel nuts:

⌚ : 98 - 118 N·m (10 - 12 kg·m, 72 - 87 ft·lb)

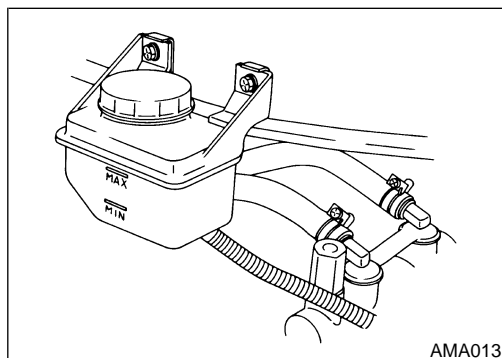

AMA013

Checking Brake Fluid Level and Leaks

NDMA0007S16

If fluid level is extremely low, check brake system for leaks.

CHASSIS AND BODY MAINTENANCE

Checking Brake Lines and Cables

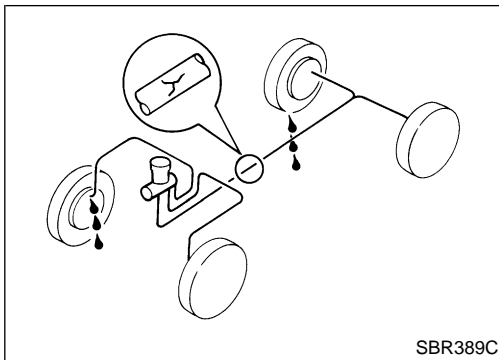

Checking Brake Lines and Cables

Check brake fluid lines and parking brake cables for improper attachment, leaks, chafing, abrasions and deterioration. NDMA0007S17

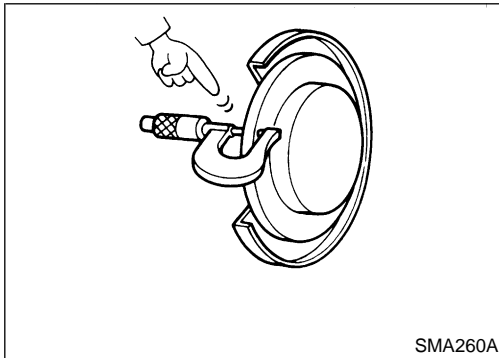

Checking Disc Brake ROTOR

Check condition and thickness. NDMA0007S18

Standard thickness:

26 mm (1.02 in)

Minimum thickness:

24 mm (0.94 in) NDMA0007S1801

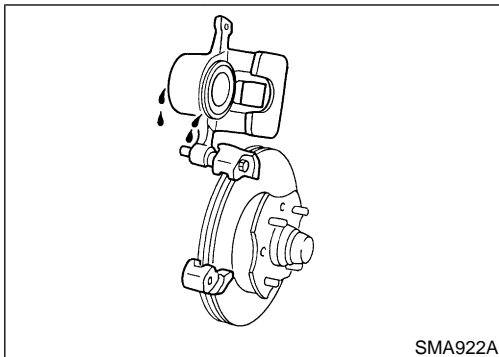

CALIPER

Check for leakage. NDMA0007S1802

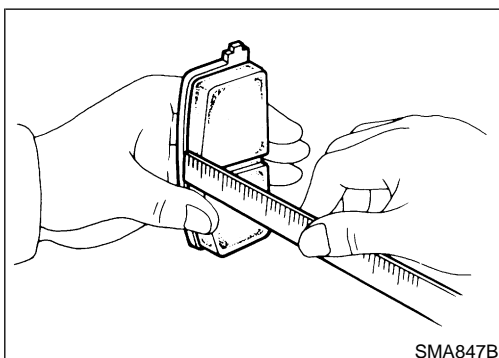

PAD

Check wear or damage. NDMA0007S1803

Standard thickness:

9.53 mm (0.375 in)

Minimum thickness: 2.0 mm (0.079 in)

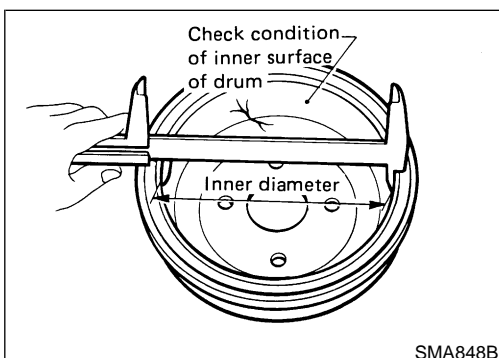

Checking Drum Brake WHEEL CYLINDER

Check for leakage. NDMA0007S19

DRUM

Check condition and inner surface. NDMA0007S1901

Standard inner diameter:

250 mm (9.84 in)

Drum repair limit (Inner diameter):

251.5 mm (9.90 in) NDMA0007S1902

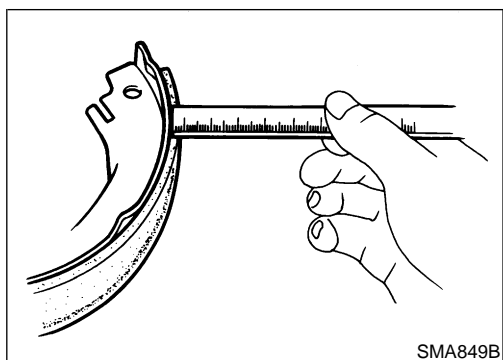

LINING

Check wear or damage.

NDMA0007S1903

Standard thickness:

5.9 mm (0.232 in)

Lining wear limit (Minimum thickness):

2.0 mm (0.079 in)

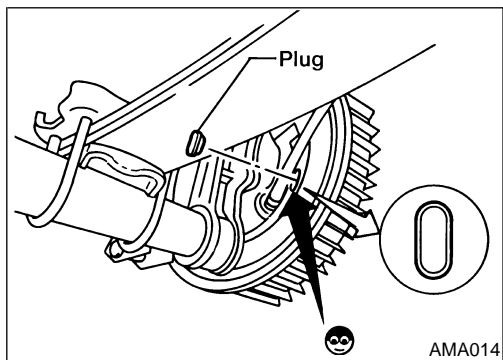

TEMPORARY METHOD FOR CHECKING LINING WEAR

NDMA0007S1904

Remove inspection hole plug and check for lining wear.

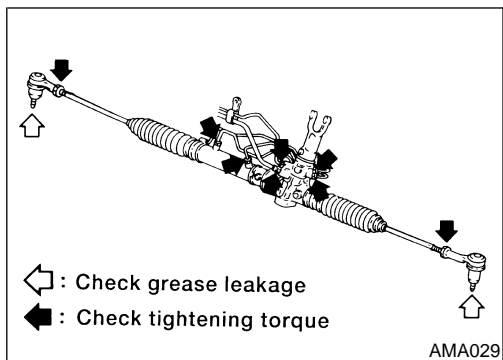

Checking Steering Gear, Linkage

NDMA0007S20

STEERING GEAR

NDMA0007S2001

- Check gear housing and boots for looseness, damage and grease leakage.
- Check connection with steering column for looseness.

STEERING LINKAGE

NDMA0007S2002

- Check ball joint, dust cover and other component parts for looseness, wear, damage and grease leakage.

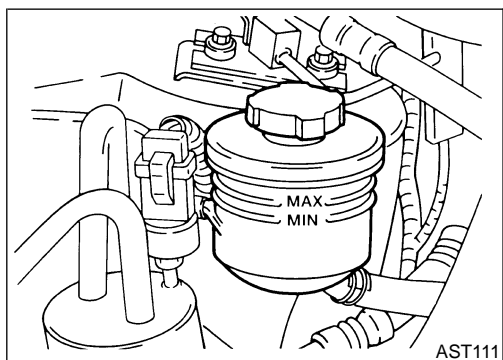

Checking Power Steering Fluid and Lines

NDMA0007S21

CHECKING FLUID LEVEL

NDMA0007S2101

- Check fluid level with engine off.
- Check fluid level with dipstick on reservoir cap. Use "HOT" range at fluid temperatures of 50 to 80°C (122 to 176°F). Use "COLD" range at fluid temperatures of 0 to 30°C (32 to 86°F).

CAUTION:

- Do not overfill.
- Recommended fluid is Type F Automatic Transmission Fluid.

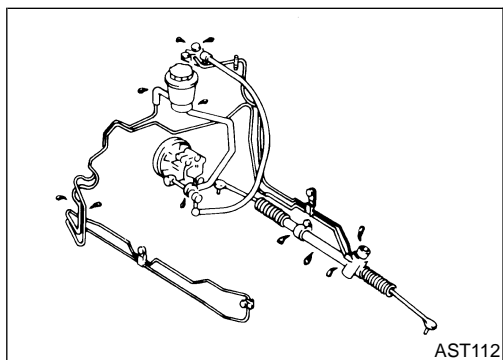

CHECKING LINES

NDMA0007S2102

- Check lines for improper attachment, leaks, cracks, damage, loose connections, chafing and deterioration.
- Check rack boots for accumulation of power steering fluid.

GI

MA

EM

LC

EC

FE

AT

AX

SU

BR

ST

RS

BT

HA

SC

EL

IDX

CHASSIS AND BODY MAINTENANCE

Lubricating Locks, Hinges and Hood Latches

Lubricating Locks, Hinges and Hood Latches

NDMA0007S22

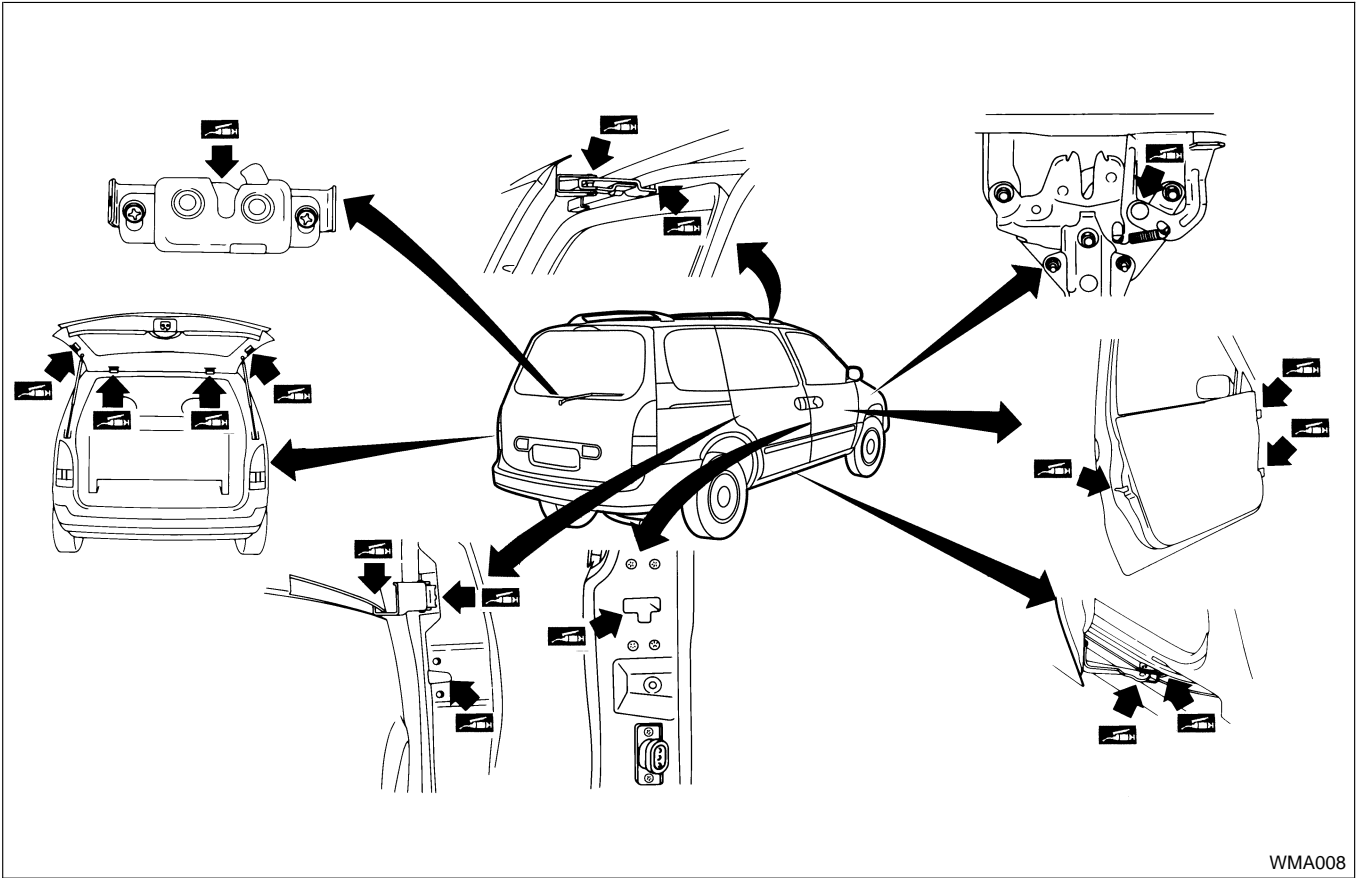

WMA008

Checking Seat Belts, Buckles, Retractors, Anchors and Adjusters

NDMA0007S23

CAUTION:

- After any collision, inspect all seat belt assemblies, including retractors and other attached hardware. NISSAN recommends replacement of all seat belt assemblies in use during a collision, unless not damaged and properly operating after a minor collision. Also inspect seat belt assemblies not in use during a collision, and replace if damaged or improperly operating.
- If any component of seat belt assembly is questionable, do not repair. Replace as seat belt assembly.
- If webbing is cut, frayed, or damaged, replace belt assembly.
- Never oil tongue and buckle.
- Use a NISSAN genuine seat belt assembly.
- For anchor bolt tightening torque, refer to RS section.
- For details, refer to "Seat Belt Inspection" "SEAT BELTS" in RS section

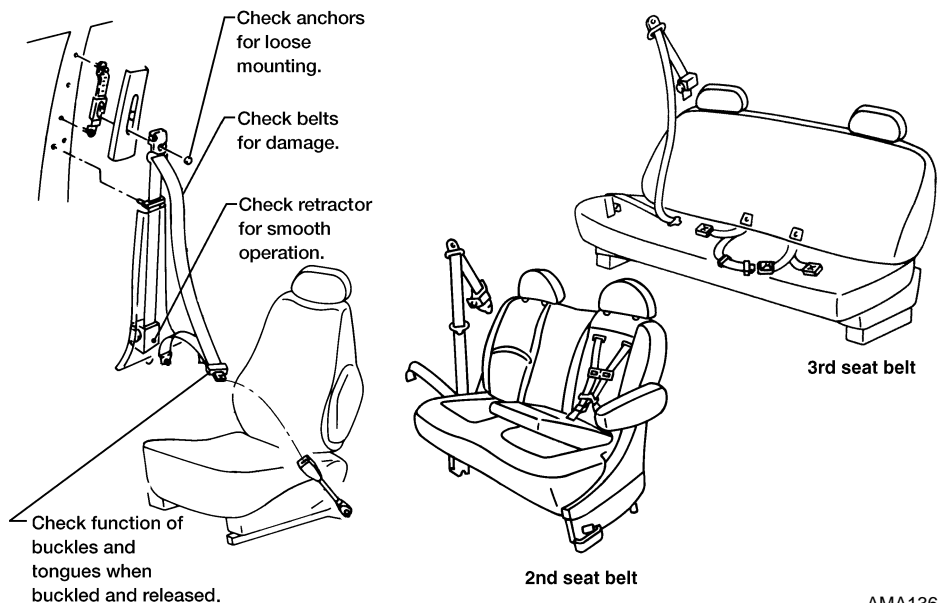

AMA136

SERVICE DATA AND SPECIFICATIONS (SDS)

Engine Maintenance

Engine Maintenance

NDMA0008

DRIVE BELT DEFLECTION

NDMA0008S01
Unit: mm (in)

| | Used belt | | New belt |
|----------------------------|---------------------|---------------------------|---------------------------|
| | Limit | After adjustment | |
| Generator | 12 (0.47) | 7.5 - 8.5 (0.295 - 0.335) | 6.5 - 7.5 (0.256 - 0.295) |
| Air conditioner compressor | 10 (0.39) | 5 - 7 (0.20 - 0.28) | 4 - 6 (0.16 - 0.24) |
| Power steering oil pump | 16 (0.63) | 10 - 12 (0.39 - 0.47) | 8 - 10 (0.31 - 0.39) |
| Applied pushing force | 98 N (10 kg, 22 lb) | | |

DRIVE BELT TENSION

NDMA0008S03
Unit: N (kg, lb)

| | Used belt | | New belt |
|----------------------------|--------------|----------------------------------------|----------------------------------------|
| | Limit | After adjustment | |
| Generator | 225 (23, 51) | 554 - 642 (56.5 - 65.5, 124.6 - 144.4) | 671 - 759 (68.5 - 77.5, 151.0 - 170.9) |
| Air conditioner compressor | 196 (20, 44) | 495 - 583 (50.5 - 59.5, 111.4 - 131.2) | 603 - 691 (61.5 - 70.5, 135.6 - 155.5) |
| Power steering oil pump | 196 (20, 44) | 495 - 583 (50.5 - 59.5, 111.4 - 131.2) | 603 - 691 (61.5 - 70.5, 135.6 - 155.5) |

SPARK PLUG TYPE

NDMA0008S02

| | |
|-----------------------|----------------|
| Standard type | PFR5G-11 (NGK) |
| Cold type | PFR6G-11 (NGK) |
| Hot type | PFR4G-11 (NGK) |
| Gap (Nominal) mm (in) | 1.1 (0.043) |

Chassis and Body Maintenance

NDMA0009

WHEEL BALANCE

NDMA0009S01

| | | |
|-----------------------------|--------------------------------|----------------------|
| Maximum allowable unbalance | Dynamic (At rim flange) g (oz) | 10 (0.35) (one side) |
| | Static g (oz) | 20 (0.71) |

NOTES