

A

# SECTION LU

LU

## ENGINE LUBRICATION SYSTEM

C

### CONTENTS

D

E

<b>PRECAUTIONS</b> .....	<b>2</b>	<b>OIL PUMP</b> .....	<b>10</b>	F
Precautions for Liquid Gasket .....	2	Removal and Installation .....	10	
REMOVAL OF LIQUID GASKET SEALING .....	2	REMOVAL .....	10	
LIQUID GASKET APPLICATION PROCEDURE.....	2	INSTALLATION .....	10	G
<b>PREPARATION</b> .....	<b>3</b>	Disassembly and Assembly .....	11	
Special Service Tools .....	3	DISASSEMBLY .....	11	
Commercial Service Tool .....	4	INSPECTION AFTER DISASSEMBLY .....	11	H
<b>LUBRICATION SYSTEM</b> .....	<b>5</b>	ASSEMBLY .....	13	H
Lubrication Circuit .....	5	<b>OIL COOLER</b> .....	<b>14</b>	
System Drawing .....	6	Removal and Installation .....	14	
<b>ENGINE OIL</b> .....	<b>7</b>	REMOVAL .....	14	I
Inspection .....	7	INSPECTION AFTER REMOVAL .....	15	
OIL LEVEL .....	7	INSTALLATION .....	15	
OIL APPEARANCE .....	7	INSPECTION AFTER INSTALLATION .....	15	J
OIL LEAKAGE .....	7	<b>SERVICE DATA AND SPECIFICATIONS (SDS)</b> .....	<b>16</b>	
OIL PRESSURE CHECK .....	7	Standard and Limit .....	16	
Changing Engine Oil .....	8	OIL PRESSURE .....	16	K
<b>OIL FILTER</b> .....	<b>9</b>	REGULATOR VALVE .....	16	
Removal and Installation .....	9	OIL PUMP .....	16	
REMOVAL .....	9	OIL CAPACITY (APPROXIMATE) .....	16	L
INSTALLATION .....	9			

M

# PRECAUTIONS

PFP:00001

EBS00G62

## PRECAUTIONS

### Precautions for Liquid Gasket REMOVAL OF LIQUID GASKET SEALING

- After removing the bolts and nuts, separate the mating surface and remove the sealant using Tool.

**Tool number : KV10111100 (J-37228)**

**CAUTION:**

**Be careful not to damage the mating surfaces.**

- In areas where the Tool is difficult to use, use a plastic hammer to lightly tap the areas where the sealant is applied.

**CAUTION:**

**If for some unavoidable reason a tool such as a flat-bladed screwdriver is used, be careful not to damage the mating surfaces.**

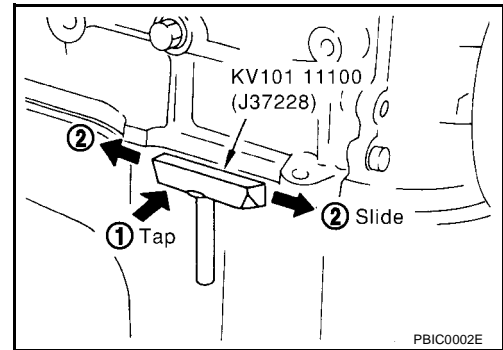

### LIQUID GASKET APPLICATION PROCEDURE

- Using a scraper, remove the old sealant adhering to the mating surface.
  - Remove the sealant completely from the groove, mounting bolts, and bolt holes.
- Thoroughly clean the mating surface removing any adhering moisture, grease and foreign material.

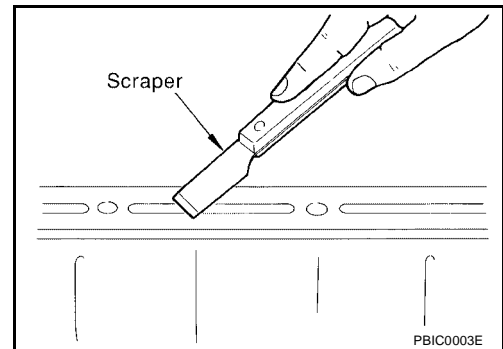

- Attach the sealant tube to the Tool.

**Tool number : WS39930000 ( — )**

- Use Genuine RTV Silicone Sealant or equivalent. Refer to [GI-43, "RECOMMENDED CHEMICAL PRODUCTS AND SEALANTS"](#).
- Apply the sealant without breaks to the specified location with the specified dimensions using Tool.
    - If there is a groove for the sealant application, apply the sealant to the groove.

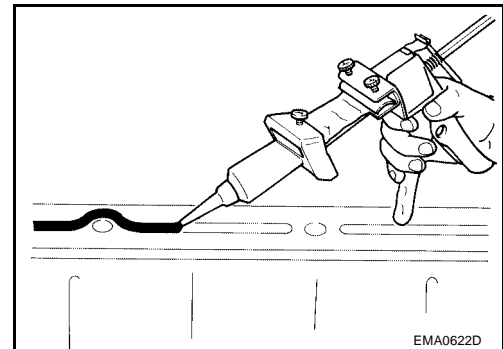

- As for the bolt holes, normally apply the sealant inside the holes. Occasionally, it should be applied outside the holes. Make sure to read the text of service manual.
- Within five minutes of sealant application, install the mating component.
- If the sealant protrudes, wipe it off immediately.
- Do not retighten after the installation.
- After 30 minutes or more have passed from the installation, fill the engine with the proper oil and coolant. Refer to [MA-10, "RECOMMENDED FLUIDS AND LUBRICANTS"](#).

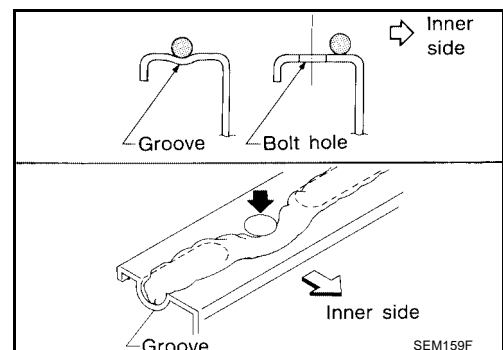

# PREPARATION

PFP:00002

## PREPARATION

### Special Service Tools

EBS00G63

The actual shapes of Kent-Moore tools may differ from those of special service tools illustrated here.

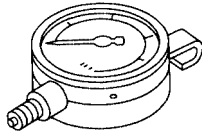
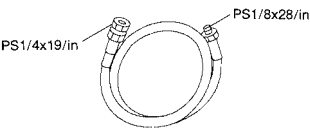
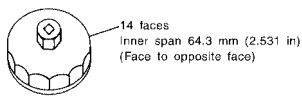
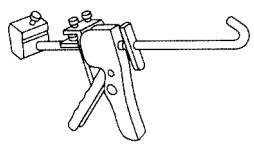
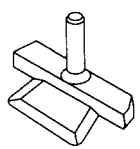
Tool number (Kent-Moore No.) Tool name	Description
ST25051001 (J-25695-1) Oil pressure gauge	Measuring oil pressure <b>Maximum measuring range: 2,452 kPa (25 kg-cm<sup>2</sup> , 356 psi)</b>
 <p style="text-align: center;">NT050</p>	
ST25052000 (J-25695-2) Hose	Adapting oil pressure gauge to upper oil pan
 <p style="text-align: center;">S-NT559</p>	
KV10115801 (J-38956) Oil filter wrench	Removing and installing oil filter
 <p style="text-align: center;">S-NT772</p>	
WS39930000 ( — ) Tube presser	Pressing the tube of liquid gasket
 <p style="text-align: center;">NT052</p>	
KV10111100 (J-37228) Seal cutter	Removing steel oil pan and rear timing chain case
 <p style="text-align: center;">NT046</p>	

A

LU

C

D

E

F

G

H

I

J

K

L

M

# PREPARATION

## Commercial Service Tool

EBS00G64

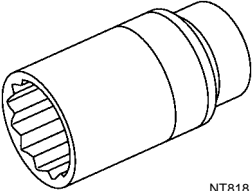
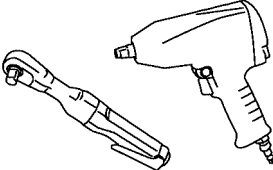
Tool name	Description
<p data-bbox="162 247 292 273">Deep socket</p>  <p data-bbox="852 447 896 464">NT818</p>	<p data-bbox="1015 247 1453 304">Removing and installing oil pressure switch Deep socket size 26 mm, 3/8 drive</p>
<p data-bbox="162 478 292 504">Power tools</p>  <p data-bbox="852 678 925 695">PBIC0190E</p>	<p data-bbox="1015 478 1266 504">Loosening nuts and bolts</p>

# LUBRICATION SYSTEM

PFP:15010

## LUBRICATION SYSTEM

### Lubrication Circuit

EBS00G65

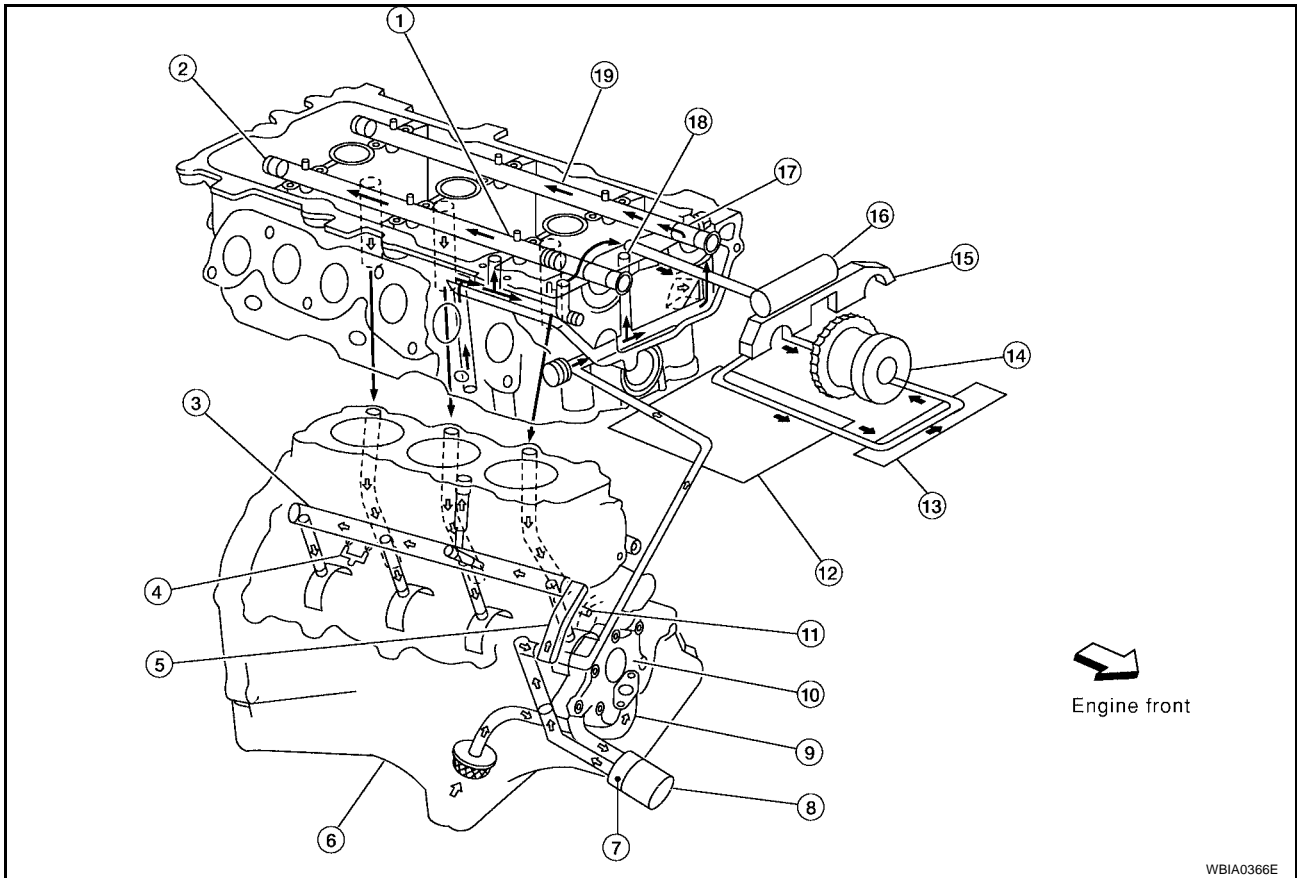

WBIA0366E

- |                                    |                                      |  |
|------------------------------------|--------------------------------------|--|
| 1. Intake camshaft journal (No. 2) | 2. Intake camshaft                   | 3. Main oil gallery                      |
| 4. Piston oil jet                  | 5. Chain case oil gallery            | 6. Oil pan                               |
| 7. Oil cooler                      | 8. Oil filter                        | 9. Oil strainer                          |
| 10. Oil pump                       | 11. Timing chain oil jet             | 12. Chain case                           |
| 13. IVT control cover              | 14. IVT controller                   | 15. No. 1 camshaft bracket               |
| 16. IVT control solenoid valve     | 17. Exhaust camshaft journal (No. 1) | 18. Camshaft chain tensioner oil gallery |
| 19. Exhaust camshaft               |                                      |  |

A

LU

C

D

E

F

G

H

I

J

K

L

M

# LUBRICATION SYSTEM

## System Drawing

EBS00G66

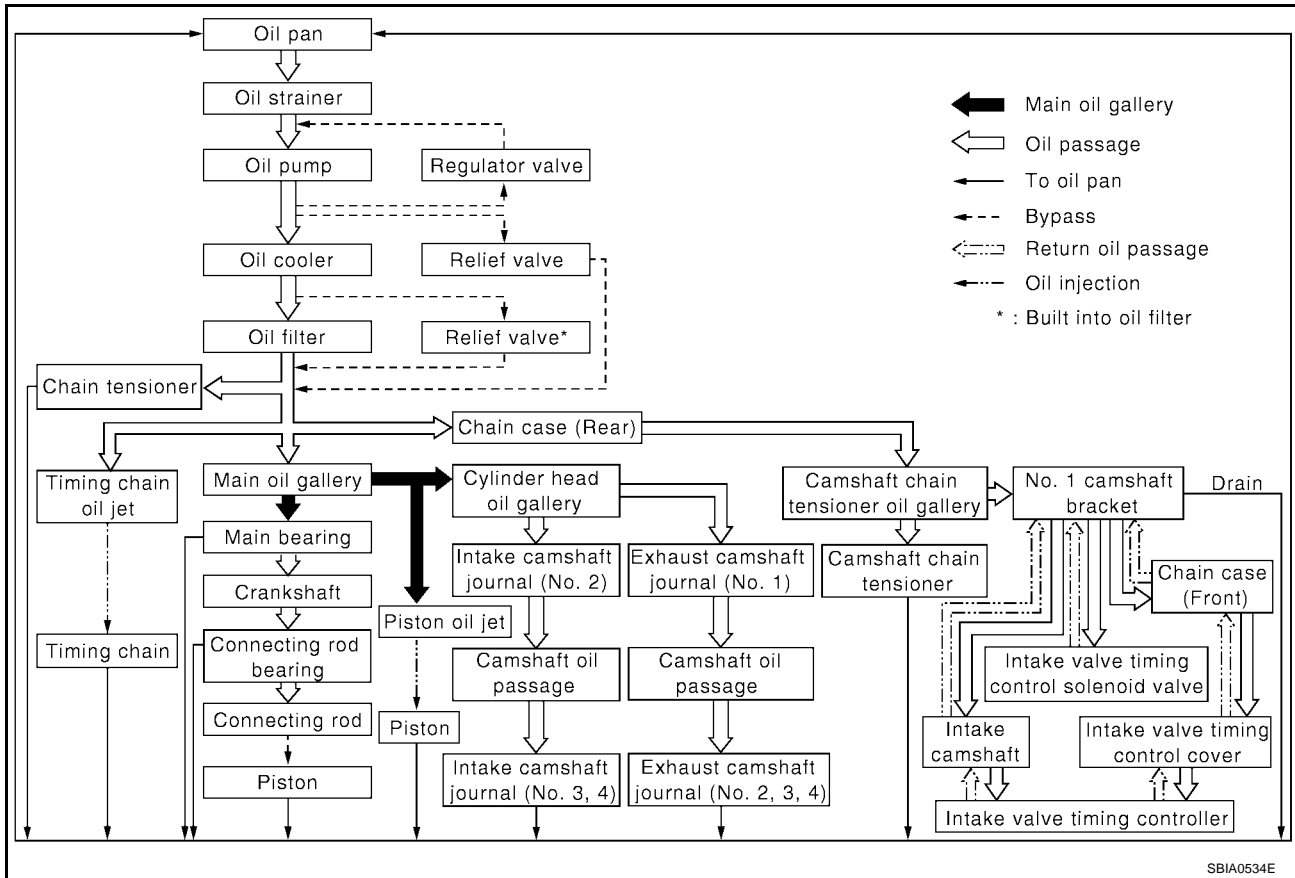

# ENGINE OIL

PFP:KLA92

EBS00G67

## ENGINE OIL

### Inspection OIL LEVEL

- Before starting the engine make sure the vehicle is parked on a flat and level surface, then check the oil level. If the engine is already running, turn it off and allow five minutes before checking.
- Check that the oil level is within the low (L) and high (H) range as indicated on the dipstick.
- If the engine oil level is out of range, add oil as necessary. Refer to [MA-10, "RECOMMENDED FLUIDS AND LUBRICANTS"](#).

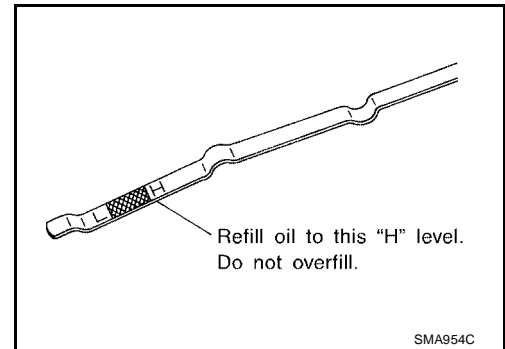

### OIL APPEARANCE

- Check the oil for white turbidity or heavy contamination.
- If the oil becomes turbid and white, it is highly probable that it is contaminated with coolant.

### OIL LEAKAGE

Check for oil leakage around the following areas:

- Upper and lower oil pan
- Oil pan drain plug
- Oil pressure switch
- Oil filter
- Oil cooler
- Water pump cover
- Timing chain tensioner cover
- Intake valve timing (IVT) control cover and intake valve timing (IVT) control solenoid valve
- Front cover
- Mating surface between cylinder block and cylinder head
- Mating surface between cylinder head and rocker cover
- Mating surface between the front timing chain case and rear timing chain case
- Mating surface between the front timing chain case and rear timing chain case
- Crankshaft oil seal (front and rear)

### OIL PRESSURE CHECK

#### **WARNING:**

- **Be careful not to burn yourself, as engine oil may be hot.**
  - **Put the selector lever in the Park "P" position.**
1. Check the oil level. Refer to [LU-7, "OIL LEVEL"](#).
  2. Disconnect the oil pressure sensor harness connector.
  3. Remove the oil pressure sensor.
  4. Install Tools.

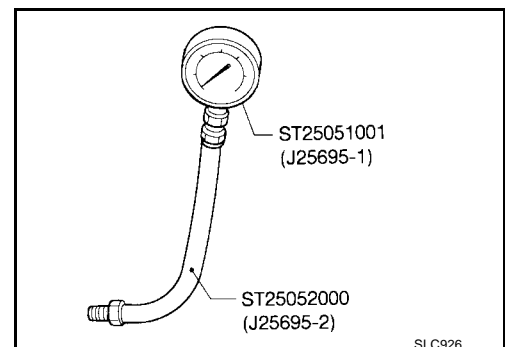

# ENGINE OIL

5. Start the engine and warm it up to normal operating temperature.
6. Check oil pressure with engine running under no-load.

Engine Speed	Approximate Discharge Pressure
Idle speed	More than 98 kPa (1.0 kg/cm <sup>2</sup> , 14 psi)
2,000 rpm	294 kPa (3.0 kg/cm <sup>2</sup> , 43 psi)

**CAUTION:**

**If the difference is extreme, check the oil passages and oil pump for leaks and blockages.**

7. After the inspections, install the oil pressure switch as follows:
  - a. Remove the old sealant adhering to switch and engine.
  - b. Apply thread sealant and tighten the oil pressure switch to specification using Tool.
    - Use Genuine High Performance Thread Sealant, or equivalent. Refer to [GI-43, "RECOMMENDED CHEMICAL PRODUCTS AND SEALANTS"](#) .

**Oil pressure switch : 14.8 N·m (1.5 kg-m, 11 ft-lb)**

## Changing Engine Oil

EBS00G68

**WARNING:**

- Be careful not to burn yourself, as the engine oil may be hot.
  - Prolonged and repeated contact with used engine oil may cause skin cancer; try to avoid direct skin contact with used oil. If skin contact is made, wash thoroughly with soap or hand cleaner as soon as possible.
1. Park the vehicle on a flat and level surface, then start the engine to warm up the oil.
  2. Check for oil leaks from the engine.
  3. Stop the engine and wait for five minutes.
  4. Remove the drain plug and oil filler cap.
  5. Drain the engine oil.
  6. Install the drain plug.

**CAUTION:**

- Be sure to clean drain plug and install with new washer.

**Oil pan drain plug : 34.3 N·m (3.5 kg-m, 25 ft-lb)**

- Refill the engine with the specified new engine oil. Refer to [MA-10, "RECOMMENDED FLUIDS AND LUBRICANTS"](#) .

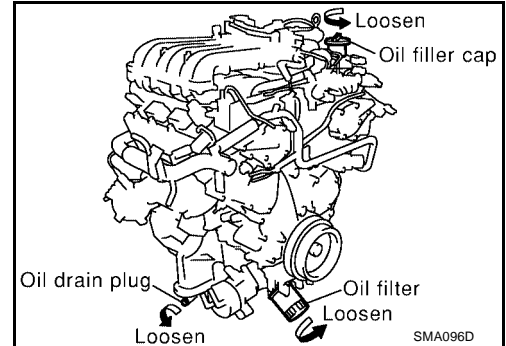

### Oil Capacity (Approximate)

Drain and refill	With oil filter change	4.0 ℓ (4 1/4 US qt, 3 1/2 Imp qt)
	Without oil filter change	3.7 ℓ (3 7/8 US qt, 3 1/4 Imp qt)
Dry engine (engine overhaul)		5.0 ℓ (5 1/4 US qt, 4 3/8 Imp qt)

**CAUTION:**

- The refill capacity depends on the oil temperature and drain time. Use these specifications for reference only.
  - Always use the dipstick to determine when the proper amount of oil is in the engine.
7. Warm up the engine and check the area around the drain plug and oil filter for oil leaks.
  8. Stop the engine and wait for five minutes.
  9. Check the oil level. Refer to [LU-7, "OIL LEVEL"](#) .



# OIL FILTER

PFP:15208

EBS00G69

## OIL FILTER

### Removal and Installation

#### REMOVAL

1. Remove the splash shield.
2. Remove the oil filter using Tool.

**Tool number** : KV10115801 (J-38956)

#### CAUTION:

- The oil filter is provided with a relief valve. Use a genuine NISSAN oil filter, or equivalent.
- Be careful not to get burned, the engine oil may be hot.
- When removing, prepare a shop cloth to absorb any oil leakage or spillage.
- Do not allow engine oil to adhere to the drive belts.
- Completely wipe off any oil that adheres to the engine and the vehicle.

#### INSTALLATION

1. Remove any foreign material adhering to the oil filter installation surface on the oil cooler.
2. Apply engine oil to the oil seal contact surface of the new oil filter as shown.

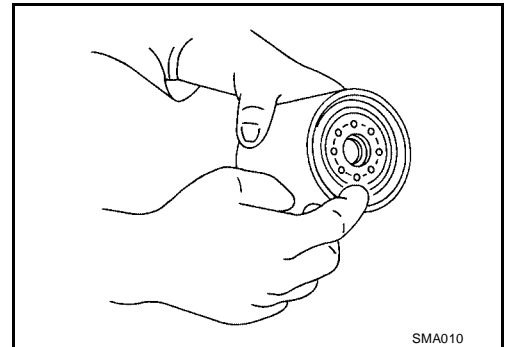

3. Screw the oil filter manually until it touches the installation surface, then tighten it by 2/3 turn as shown. Or tighten to specification using Tool.

**Oil filter** : 17.6 N·m (1.8 kg-m, 13 ft-lb)

**Tool number** : KV10115801 (J-38956)

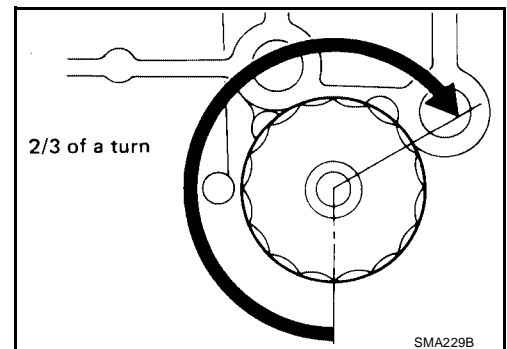

4. After warming up the engine, check for engine oil leakage.
5. Install the splash shield.
6. Check oil level and add engine oil as necessary. Refer to [LU-7, "ENGINE OIL"](#) .

# OIL PUMP

## OIL PUMP

PF15010

## Removal and Installation

EBS00G6A

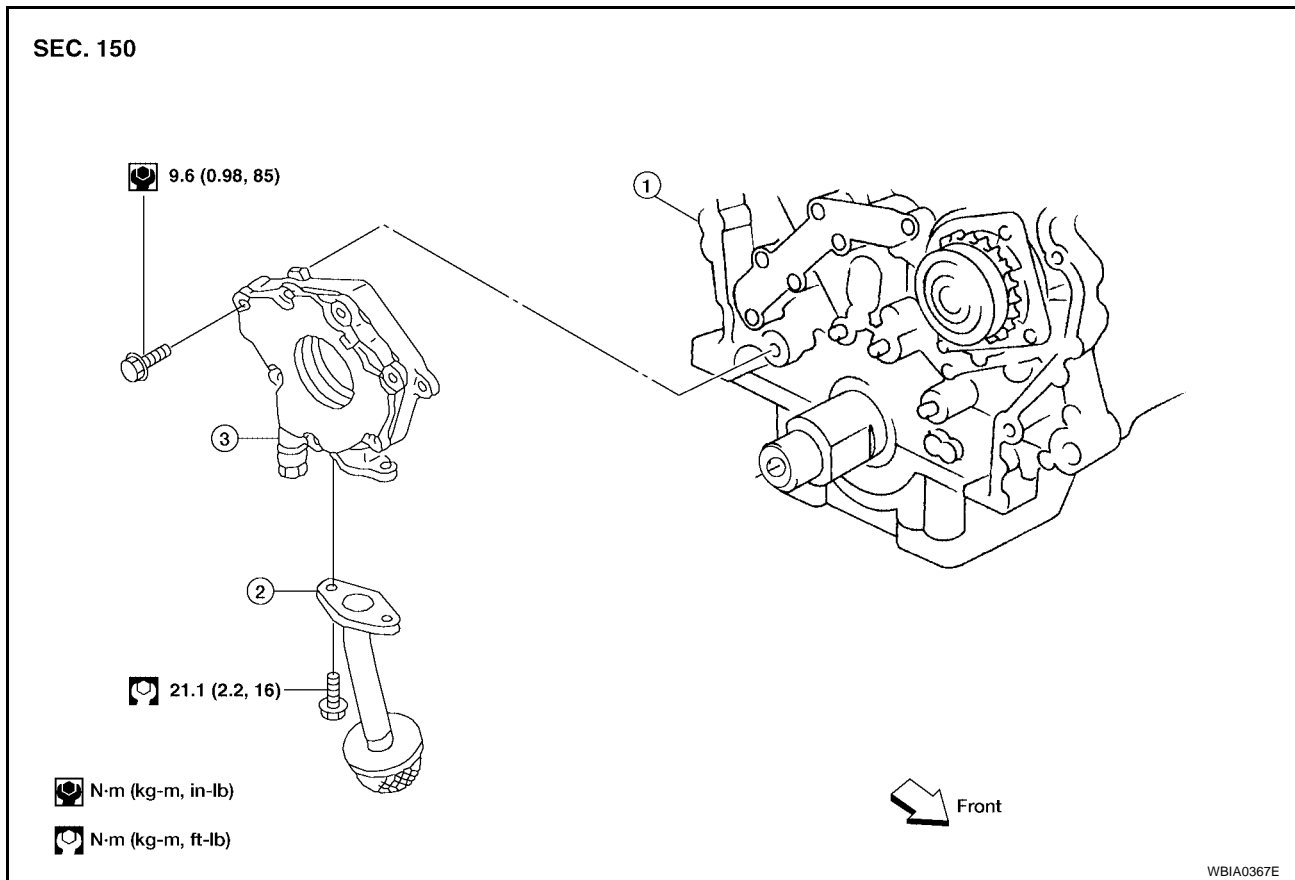

1. Cylinder block

2. Oil strainer

3. Oil pump

### REMOVAL

1. On 5 A/T equipped vehicles, remove the engine/transaxle/front suspension member. Refer to [EM-133, "Removal and Installation"](#).
2. Remove the timing chain. Refer to [EM-58, "Removal and Installation"](#).
3. Remove the oil strainer.
4. Remove the oil pump.

### INSTALLATION

Installation is in the reverse order of removal.

# OIL PUMP

## Disassembly and Assembly

EBS00G6B

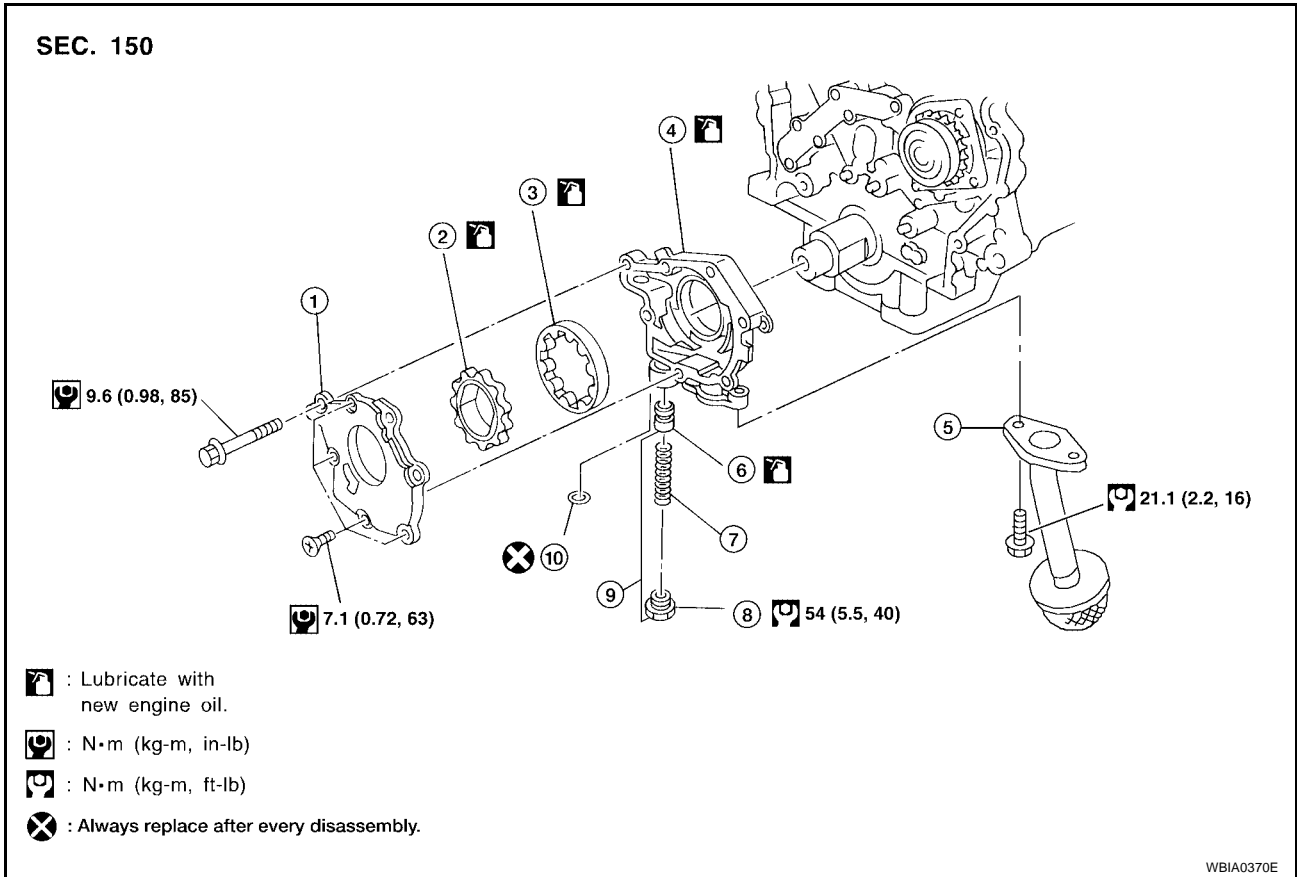

- |                     |                   |                                      |
|---------------------|-------------------|--------------------------------------|
| 1. Oil pump cover   | 2. Inner rotor    | 3. Outer rotor                       |
| 4. Oil pump body    | 5. Oil strainer   | 6. Regulator valve                   |
| 7. Regulator spring | 8. Regulator plug | 9. Regulator valve set (6, 7, and 8) |
| 10. O-ring          |                   |                                      |

### DISASSEMBLY

- Remove oil pump cover.
- Remove oil pump inner rotor and oil pump outer rotor from oil pump body.
- Remove the regulator valve plug, regulator valve spring and regulator valve.

### INSPECTION AFTER DISASSEMBLY

#### Clearance of Oil Pump Parts

- Measure the rotor clearance with a feeler gauge as shown.
  - Clearance between outer rotor and oil pump body (position 1).  
**Position 1 : 0.114 - 0.200 mm (0.0045 - 0.0079 in)**
  - Tip clearance between inner rotor and outer rotor (position 2).  
**Position 2 : less than 0.180 mm (0.0071 in)**

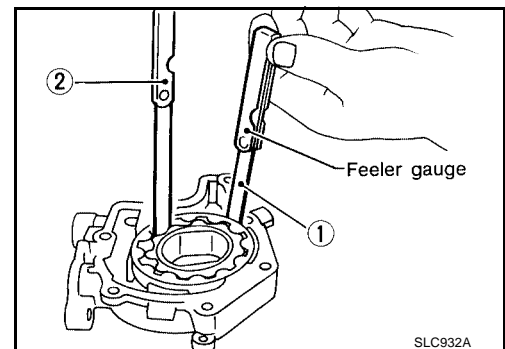

# OIL PUMP

- Measure the rotor clearance with a feeler gauge and straightedge as shown.
- Side clearance is between the inner rotor and the oil pump body (position 3).

**Position 3 : 0.030 - 0.070 mm (0.0012 - 0.0028 in)**

- Side clearance is between the outer rotor and the oil pump body (position 4).

**Position 4 : 0.050 - 0.110 mm (0.0020 - 0.0043 in)**

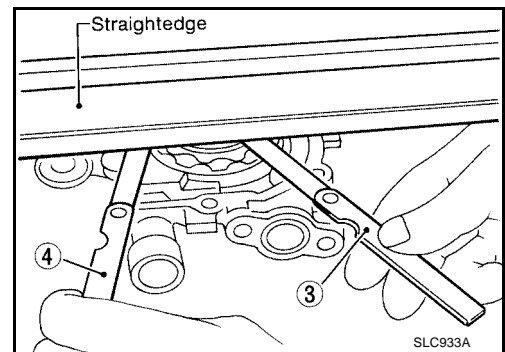

- Calculate the clearance between inner rotor and oil pump body as follows.
- Measure the outer diameter of protruded portion of inner rotor (position A).
- Measure the inner diameter of oil pump body with inside micrometer (position B).
- Clearance 5 = (inner diameter of oil pump body B) – (outer diameter of inner rotor A).

**Clearance 5 : 0.045 - 0.091 mm (0.0018 - 0.0036 in)**

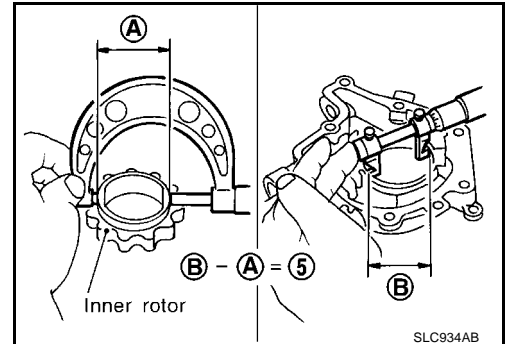

## Regulator Valve

1. Visually inspect the components for wear and damage.
2. Check the regulator valve sliding surface and the regulator spring.
3. Coat the regulator valve with engine oil. Check that the regulator valve falls smoothly into the valve hole by its own weight.
4. If damaged, replace the regulator valve set or the oil pump body as necessary.

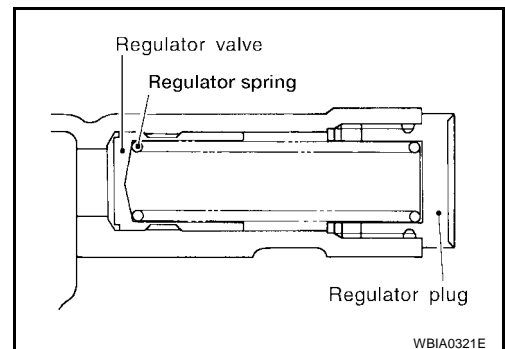

## Regulator Valve to Oil Pump Body Clearance

- Clearance 6 = (regulator valve hole diameter D) – (outer regulator valve diameter E).
- If the calculated clearance 6 exceeds the standard, replace the oil pump body.

**Clearance 6 : 0.040 - 0.097 mm (0.0016 - 0.0038 in)**

### CAUTION:

- Coat the regulator valve with clean engine oil.
- Check that it falls smoothly into the valve hole by its own weight.

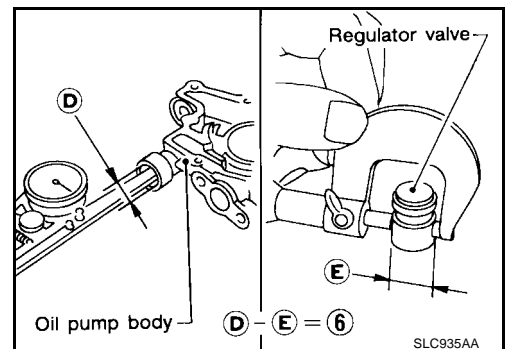

# OIL PUMP

## ASSEMBLY

Assembly is in the reverse order of disassembly.

- Assemble the inner rotor and outer rotor with the punch marks on the oil pump cover side.

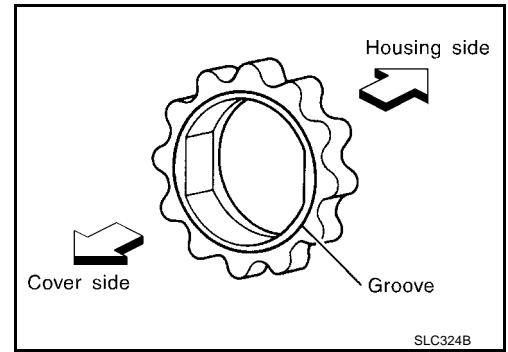

A

LU

C

D

E

F

G

H

I

J

K

L

M

# OIL COOLER

PF21305

## OIL COOLER

### Removal and Installation

EBS00G6C

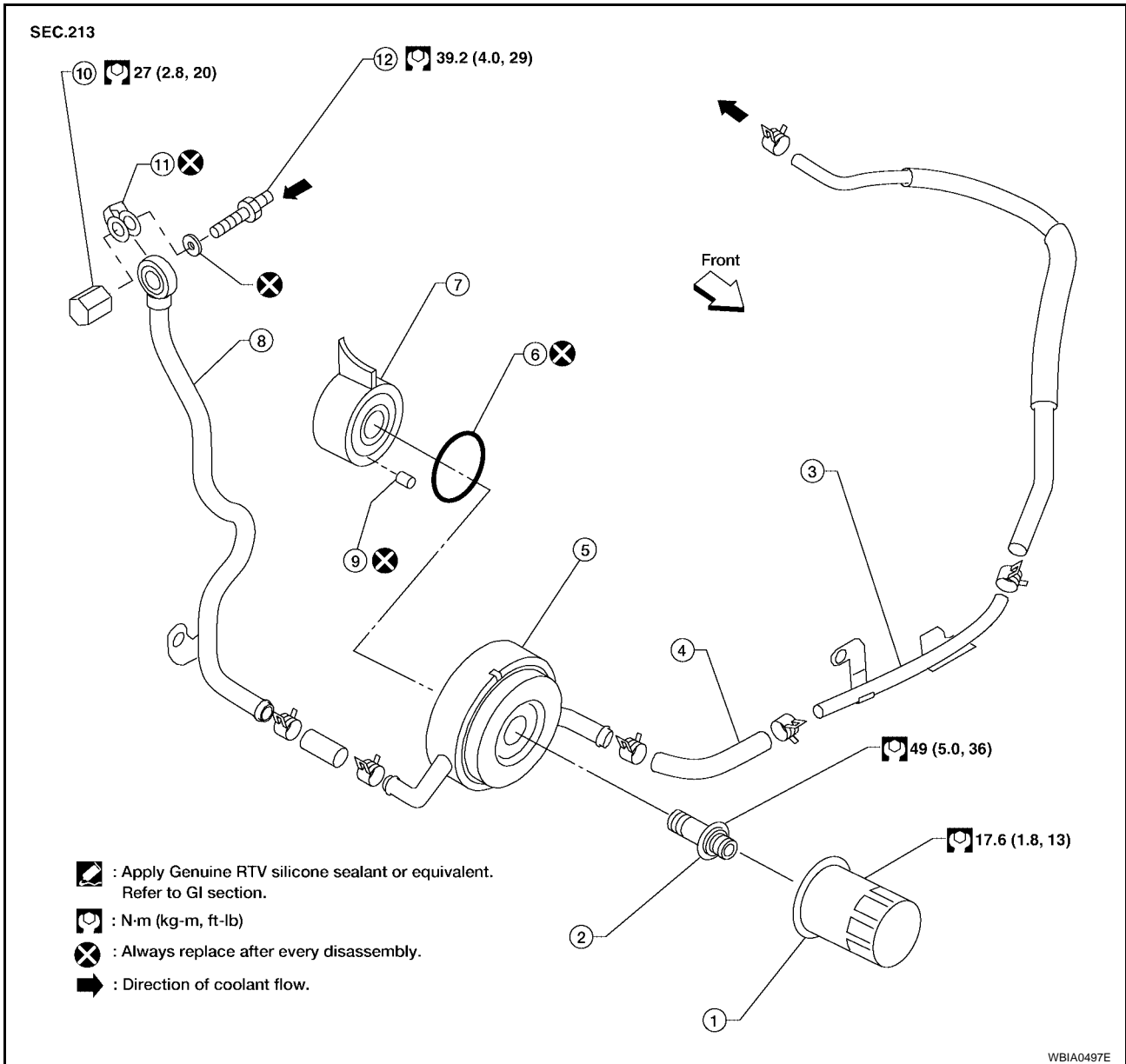

- |                        |                       |                        |
|------------------------|-----------------------|------------------------|
| 1. Oil filter          | 2. Oil cooler bolt    | 3. Coolant outlet pipe |
| 4. Coolant outlet hose | 5. Oil cooler         | 6. O-ring              |
| 7. Oil pan             | 8. Coolant inlet pipe | 9. Relief valve        |
| 10. Drain plug         | 11. Copper gasket     | 12. Water connector    |

### REMOVAL

1. Drain the engine oil. Refer to [MA-18, "Changing Engine Oil"](#).
2. Drain the engine coolant. Refer to [MA-14, "DRAINING ENGINE COOLANT"](#).
3. Remove the oil filter. Refer to [LU-9, "Removal and Installation"](#).
4. Remove the wheel and tire assembly using power tool.
5. Remove the splash shield.
6. Disconnect the coolant hoses from the oil cooler.

### CAUTION:

**Do not spill coolant on the drive belt.**

7. Remove the oil cooler from the upper oil pan.

# OIL COOLER

## INSPECTION AFTER REMOVAL

### Oil Cooler

Check the oil cooler for cracks. Check the oil cooler for clogging by blowing through the coolant inlet. If necessary, replace the oil cooler.

### Relief Valve

Inspect the relief valve for movement, cracks, and breaks by pushing the ball. If replacement is necessary, remove the relief valve by prying it out with a suitable tool. Install a new relief valve by tapping it into place with a suitable tool.

## INSTALLATION

Installation is in the reverse order of removal.

- When installing the oil cooler, align the stopper slot with the stopper on the upper oil pan.
- Install the wheel and tire assembly. Refer to [WT-6, "Rotation"](#) for torque specification.

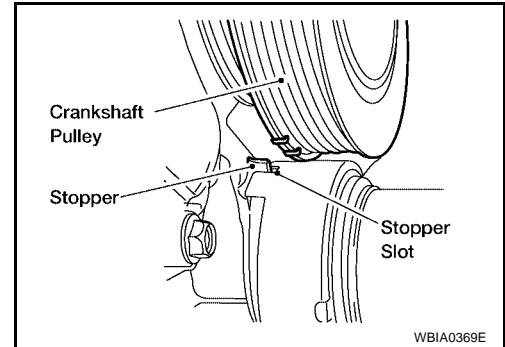

## INSPECTION AFTER INSTALLATION

1. Check level and add engine oil and engine coolant. Refer to [LU-7, "OIL LEVEL"](#) and [CO-9, "CHECKING RESERVOIR LEVEL"](#).
2. Start the engine and check that there are no leaks of engine oil or engine coolant.
3. Stop engine and wait for 10 minutes.
4. Check engine oil level and engine coolant level.

# SERVICE DATA AND SPECIFICATIONS (SDS)

## SERVICE DATA AND SPECIFICATIONS (SDS)

PF0:00100

### Standard and Limit OIL PRESSURE

EBS00G6D

Engine speed	Approximate discharge pressure
Idle speed	More than 98 kPa (1.0 kg/cm <sup>2</sup> , 14 psi)
2,000 rpm	294 kPa (3.0 kg/cm <sup>2</sup> , 43 psi)

### REGULATOR VALVE

Unit: mm (in)

Regulator valve to oil pump body clearance	0.040 - 0.097 (0.0016 - 0.0038)
--	---------------------------------

### OIL PUMP

Unit: mm (in)

Oil pump body to outer rotor radial clearance	0.114 - 0.200 (0.0045 - 0.0079)
Oil pump inner rotor to outer rotor tip clearance	Below 0.18 (0.0071)
Oil pump body to inner rotor axial clearance	0.030 - 0.070 (0.0012 - 0.0028)
Oil pump body to outer rotor axial clearance	0.050 - 0.110 (0.0020 - 0.0043)
Inner rotor to oil pump (brazed portion of housing) clearance	0.045 - 0.091 (0.0018 - 0.0036)

### OIL CAPACITY (APPROXIMATE)

Unit: ℓ (US qt, Imp qt)

Drain and refill	With oil filter change	4.0 (4 1/4, 3 1/2)
	Without oil filter change	3.7 (3 7/8, 3 1/4)
Dry engine (engine overhaul)		5.0 (5 1/4, 4 3/8)