

A
B
C

WW

SECTION

WIPER, WASHER & HORN

CONTENTS

<p>PRECAUTION 3</p> <p> Precautions for Supplemental Restraint System (SRS) "AIR BAG" and "SEAT BELT PRE-TENSIONER" 3</p> <p> Wiring Diagrams and Trouble Diagnosis 3</p> <p>FRONT WIPER AND WASHER SYSTEM 4</p> <p> Components Parts and Harness Connector Location 4</p> <p> System Description 4</p> <p> LOW SPEED WIPER OPERATION 5</p> <p> HI SPEED WIPER OPERATION 5</p> <p> INTERMITTENT OPERATION 5</p> <p> AUTO STOP OPERATION 5</p> <p> FRONT WASHER OPERATION 6</p> <p> MIST OPERATION 6</p> <p> FAIL-SAFE FUNCTION 6</p> <p> COMBINATION SWITCH READING FUNCTION... 6</p> <p> CAN Communication System Description 6</p> <p> Schematic 7</p> <p> Wiring Diagram — WIPER — 8</p> <p> Terminals and Reference Values for BCM 11</p> <p> Terminals and Reference Values for IPDM E/R 12</p> <p> Work Flow 12</p> <p> Preliminary Inspection 13</p> <p> INSPECTION FOR POWER SUPPLY AND GROUND CIRCUIT 13</p> <p> CONSULT-II Function (BCM) 14</p> <p> CONSULT-II OPERATION 14</p> <p> DATA MONITOR 15</p> <p> ACTIVE TEST 15</p> <p> CONSULT-II Function (IPDM E/R) 16</p> <p> CONSULT-II OPERATION 16</p> <p> DATA MONITOR 17</p> <p> ACTIVE TEST 17</p> <p> Trouble Diagnosis 18</p> <p> FRONT WIPER DOES NOT OPERATE 18</p> <p> FRONT WIPER STOP POSITION IS INCORRECT 21</p> <p> ONLY FRONT WIPER LOW DOES NOT OPERATE 22</p>	<p> ONLY FRONT WIPER HI DOES NOT OPERATE.. 22</p> <p> ONLY FRONT WIPER INT DOES NOT OPERATE 24</p> <p> FRONT WIPER INTERMITTENT OPERATION SWITCH POSITION CANNOT BE ADJUSTED... 24</p> <p> WIPERS DO NOT WIPE WHEN FRONT WASHER OPERATES 24</p> <p> FRONT WIPERS OPERATE FOR 10 SECONDS, STOP FOR 20 SECONDS, AND AFTER REPEATING THIS OPERATION FIVE TIMES, THEY BECOME INOPERATIVE 24</p> <p> Removal and Installation of Front Wiper Arms, Adjustment of Wiper Arms Stop Location 26</p> <p> REMOVAL 26</p> <p> ADJUSTMENT 26</p> <p> INSTALLATION 26</p> <p> Removal and Installation of Wiper Motor and Linkage 27</p> <p> REMOVAL 27</p> <p> INSTALLATION 27</p> <p> Washer Nozzle Adjustment 28</p> <p> Washer Tube Layout 28</p> <p> Removal and Installation of Wiper and Washer Switch 28</p> <p> REMOVAL 28</p> <p> INSTALLATION 28</p> <p> Removal and Installation of Washer Tank 29</p> <p> Removal and Installation of Washer Motor 29</p> <p>REAR WIPER AND WASHER SYSTEM 30</p> <p> Components Parts and Harness Connector Location 30</p> <p> System Description 30</p> <p> REAR WIPER OPERATION 30</p> <p> INTERMITTENT OPERATION 31</p> <p> AUTO STOP OPERATION 31</p> <p> REAR WASHER OPERATION 31</p> <p> BCM WIPER SWITCH READING FUNCTION ... 31</p> <p> Wiring Diagram — WIP/ R — 32</p> <p> Terminals and Reference Values for BCM 34</p> <p> Terminals and Reference Values for IPDM E/R 35</p>
---	--

A
B
C
D
E
F
G
H
I
J
L
M

WW

How to Proceed With Trouble Diagnosis	35	Rear Washer Tube Layout	45
Preliminary Check	35	Removal and Installation for Rear Washer Nozzle...	45
INSPECTION FOR POWER SUPPLY AND		REMOVAL	45
GROUND CIRCUIT	35	INSTALLATION	45
CONSULT-II Function (BCM)	37	Check Valve	45
CONSULT-II OPERATION	37	Removal and Installation for Rear Wiper and	
DATA MONITOR	38	Washer Switch	45
ACTIVE TEST	38	Removal and Installation for Washer Tank	45
Rear Wiper Does Not Operate	39	Removal and Installation for Washer Motor	46
Rear Wiper Stop Position Is Incorrect	41	SOCKET	47
Only Rear Wiper Does Not Operate	42	Wiring Diagram — P/SCKT —	47
Only Rear Wiper Intermittent Does Not Operate ...	42	Removal and Installation of Power Sockets	48
Wiper Does Not Wipe When Rear Washer Operates..	42	REMOVAL	48
Removal and Installation of Rear Wiper Arm	43	INSTALLATION	48
REMOVAL	43	HORN	49
INSTALLATION	43	Wiring Diagram — HORN —	49
Removal and Installation of Rear Wiper Motor	43	Removal and Installation	50
REMOVAL	44	REMOVAL	50
INSTALLATION	44	INSTALLATION	50
Rear Washer Nozzle Adjustment	44		

PRECAUTION

PRECAUTION

PFP:00011

Precautions for Supplemental Restraint System (SRS) “AIR BAG” and “SEAT BELT PRE-TENSIONER”

EKS005QV

The Supplemental Restraint System such as “AIR BAG” and “SEAT BELT PRE-TENSIONER”, used along with a front seat belt, helps to reduce the risk or severity of injury to the driver and front passenger for certain types of collision. This system includes seat belt switch inputs and dual stage front air bag modules. The SRS system uses the seat belt switches to determine the front air bag deployment, and may only deploy one front air bag, depending on the severity of a collision and whether the front occupants are belted or unbelted. Information necessary to service the system safely is included in the SRS and SB section of this Service Manual.

WARNING:

- To avoid rendering the SRS inoperative, which could increase the risk of personal injury or death in the event of a collision which would result in air bag inflation, all maintenance must be performed by an authorized NISSAN/INFINITI dealer.
- Improper maintenance, including incorrect removal and installation of the SRS, can lead to personal injury caused by unintentional activation of the system. For removal of Spiral Cable and Air Bag Module, see the SRS section.
- Do not use electrical test equipment on any circuit related to the SRS unless instructed to in this Service Manual. SRS wiring harnesses can be identified by yellow and/or orange harnesses or harness connectors.

Wiring Diagrams and Trouble Diagnosis

EKS005QW

When you read wiring diagrams, refer to the following:

- Refer to [GI-12, "How to Read Wiring Diagrams"](#)
- Refer to [PG-4, "POWER SUPPLY ROUTING CIRCUIT"](#) for power distribution circuit.

When you perform trouble diagnosis, refer to the following:

- Refer to [GI-10, "HOW TO FOLLOW TEST GROUPS IN TROUBLE DIAGNOSES"](#) .
- Refer to [GI-25, "How to Perform Efficient Diagnosis for an Electrical Incident"](#) .

A

B

C

D

E

F

G

H

I

J

WW

L

M

FRONT WIPER AND WASHER SYSTEM

FRONT WIPER AND WASHER SYSTEM

PF2:28810

Components Parts and Harness Connector Location

EKS0050X

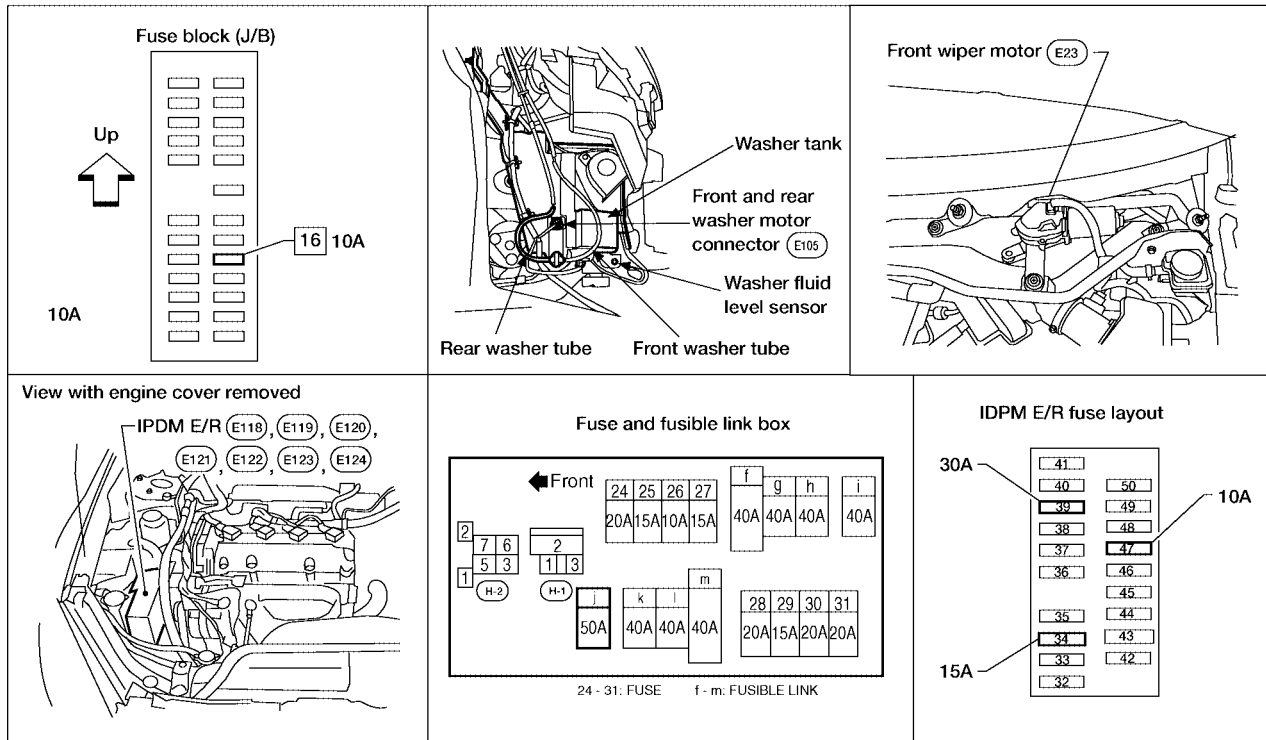

WKIA2877E

System Description

EKS0050Y

- Both front wiper relays are located in IPDM E/R (intelligent power distribution module engine room).
- Wiper switch (combination switch) is composed of a combination of 5 output terminals and 5 input terminals. Terminal combination status is read by BCM (body control module) when switch is turned ON.
- BCM controls front wiper LO, HI, and INT (intermittent) operation.
- IPDM E/R operates the wiper motor according to CAN communication signals from the BCM.

Power is supplied at all times

- through 50A fusible link (letter j, located in the fuse and fusible link box)
- to BCM terminal 55, and
- through 30A fuse (No. 39, located in the IPDM E/R)
- to front wiper relay (located in the IPDM E/R).

With the ignition switch in ON or START position, power is supplied

- through 10A fuse (No. 16, located in the fuse block J/B)
- to BCM terminal 38, and
- through 10A fuse (No. 47, located in the IPDM E/R)
- through IPDM E/R terminal 44
- to combination switch terminal 14.

Ground is supplied

- to BCM terminals 49 (early production) and 52 and
- to combination switch terminal 12
- through grounds M57, M61 and M79, and
- to IPDM E/R terminals 38 and 60 and
- to front wiper motor terminal 1

FRONT WIPER AND WASHER SYSTEM

- through grounds E9, E15 and E24.

LOW SPEED WIPER OPERATION

When the ignition switch is in the ON or START position, and the front wiper switch is turned to low position, the BCM detects a low speed wiper ON signal by BCM wiper switch reading function. BCM then sends front wiper (low) request signal over CAN communication lines

- from BCM terminals 39 and 40
- to IPDM E/R terminals 48 and 49.

When IPDM E/R receives front wiper (low) request signal, it supplies ground to energize the front wiper relay. With the front wiper relay energized, power is supplied

- through front wiper relay
- through front wiper high relay
- through IPDM E/R terminal 21
- to front wiper motor terminal 3.

With power and ground supplied, the front wiper motor operates at low speed.

HI SPEED WIPER OPERATION

When the ignition switch is in the ON or START position, and the front wiper switch is turned to high position, the BCM detects a high speed wiper ON signal by BCM wiper switch reading function. BCM then sends front wiper (high) request signal over CAN communication lines

- from BCM terminals 39 and 40
- to IPDM E/R terminals 48 and 49.

When IPDM E/R receives front wiper (high) request signal, it supplies ground to energize the front wiper and the front wiper high relays.

With the front wiper and the front wiper high relays energized, power is supplied

- through front wiper relay
- through front wiper high relay
- through IPDM E/R terminal 31
- to front wiper motor terminal 2.

With power and ground supplied, the front wiper motor operates at high speed.

INTERMITTENT OPERATION

Wiper intermittent operation delay interval is determined from the combination of the intermittent wiper dial position inputs and vehicle speed. During each intermittent operation delay interval, the BCM sends a front wiper request signal to the IPDM E/R to operate the wipers.

When the ignition switch is in ON or START position, and the front wiper switch is turned to intermittent position, the BCM detects a front wiper (intermittent) ON signal by BCM wiper switch reading function. BCM then sends front wiper (intermittent) request signal over CAN communication lines

- from BCM terminals 39 and 40
- to IPDM E/R terminals 48 and 49.

When BCM determines that combination switch status is front wiper intermittent ON, it performs the following operations.

- BCM detects ON/OFF status of intermittent wiper dial position.
- BCM calculates operation interval from wiper dial position and vehicle speed signal received through CAN communications.
- BCM sends front wiper request signal (INT) to IPDM E/R at calculated operation interval.

When IPDM E/R receives front wiper request signal (INT), it supplies ground to energize the front wiper relay. It then sends auto-stop signal to BCM, and conducts intermittent front wiper motor operation.

AUTO STOP OPERATION

When the wiper arms are not located at the base of the windshield, and the wiper switch is turned OFF, the wiper motor will continue to operate until the wiper arms reach windshield base. When wiper arms reach base of windshield, front wiper motor terminals 1 and 4 are connected.

Ground is supplied

- to IPDM E/R terminal 32

A

B

C

D

E

F

G

H

I

J

WW

L

M

FRONT WIPER AND WASHER SYSTEM

- through front wiper motor terminal 4
- through front wiper motor terminal 1
- through grounds E9, E15 and E24.

The IPDM E/R sends auto stop operation signal to BCM through CAN communication lines.

When BCM receives auto stop operation signal, BCM sends wiper stop signal to IPDM E/R with CAN communication lines. The IPDM E/R then de-energizes the front wiper relay.

Wiper motor will then stop wiper arms at the STOP position.

FRONT WASHER OPERATION

When the ignition switch is in the ON or START position, and the front and rear washer switches are OFF, the front and rear washer motor is supplied power

- through 10A fuse (No. 47, located in the IPDM E/R)
- through IPDM E/R terminal 44
- through combination switch (wiper switch) terminal 14
- through combination switch (wiper switch) terminal 13
- to front and rear washer motor terminal +, and
- through combination switch (wiper switch) terminal 11
- to front and rear washer motor terminal –.

When front wiper switch is in front washer position, BCM detects front washer signal by BCM wiper switch reading function. Combination switch ground is supplied

- to front and rear washer motor terminal –
- through combination switch (wiper switch) terminal 11
- through combination switch (wiper switch) terminal 12
- through grounds M57, M61 and M79.

With ground supplied, the front and rear washer motor is operated in the front direction.

When BCM detects that front washer motor has operated for 0.4 seconds or longer, BCM uses CAN communication and sends wiper request signal to IPDM E/R for low speed operation of wipers.

When BCM detects that washer switch is OFF, low speed operation cycles approximately 3 times and then stops.

MIST OPERATION

When the wiper switch is temporarily placed in the mist position, wiper low speed operation cycles once and then stops.

For additional information about wiper operation under this condition, refer to [WW-5, "LOW SPEED WIPER OPERATION"](#).

If the switch is held in the mist position, low speed operation continues.

FAIL-SAFE FUNCTION

BCM includes fail-safe function to prevent malfunction of electrical components controlled by CAN communications if a malfunction in CAN communications occurs.

BCM uses CAN communications to stop output of electrical components it controls.

Until ignition switch is turned off, front wiper remains in same status as just before fail-safe control was initiated. (If wiper was in low speed operation just before fail-safe, it continues low speed operation until ignition switch is turned OFF.)

When fail-safe status is initiated, BCM remains in standby until normal signals are received.

When normal signals are received, fail-safe status is canceled.

COMBINATION SWITCH READING FUNCTION

Refer to [BCS-3, "COMBINATION SWITCH READING FUNCTION"](#).

CAN Communication System Description

Refer to [LAN-6, "CAN COMMUNICATION"](#).

EKS0050Z

FRONT WIPER AND WASHER SYSTEM

Schematic

EKS00659

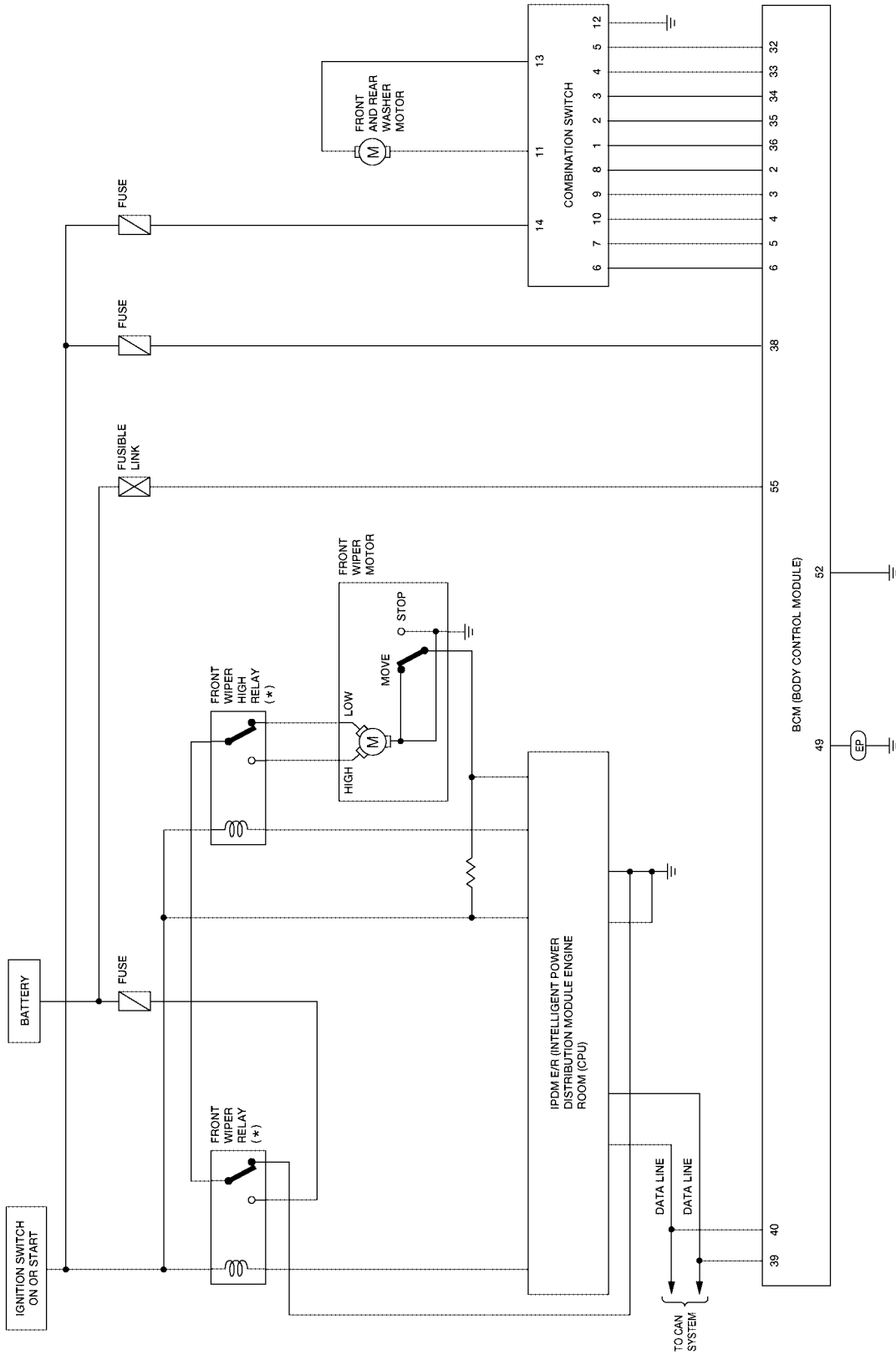

(EP) : EARLY PRODUCTION
 *: THIS RELAY IS BUILT INTO THE IPDM E/R
 (INTELLIGENT POWER DISTRIBUTION MODULE ENGINE ROOM).

A
 B
 C
 D
 E
 F
 G
 H
 I
 J
 L
 M

WW

WKWA1643E

FRONT WIPER AND WASHER SYSTEM

Wiring Diagram — WIPER —

EKS005R0

WW-WIPER-01

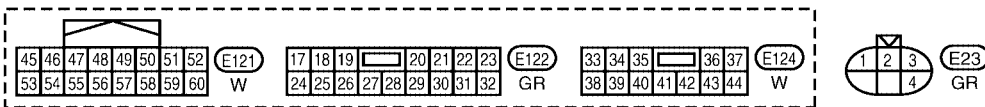
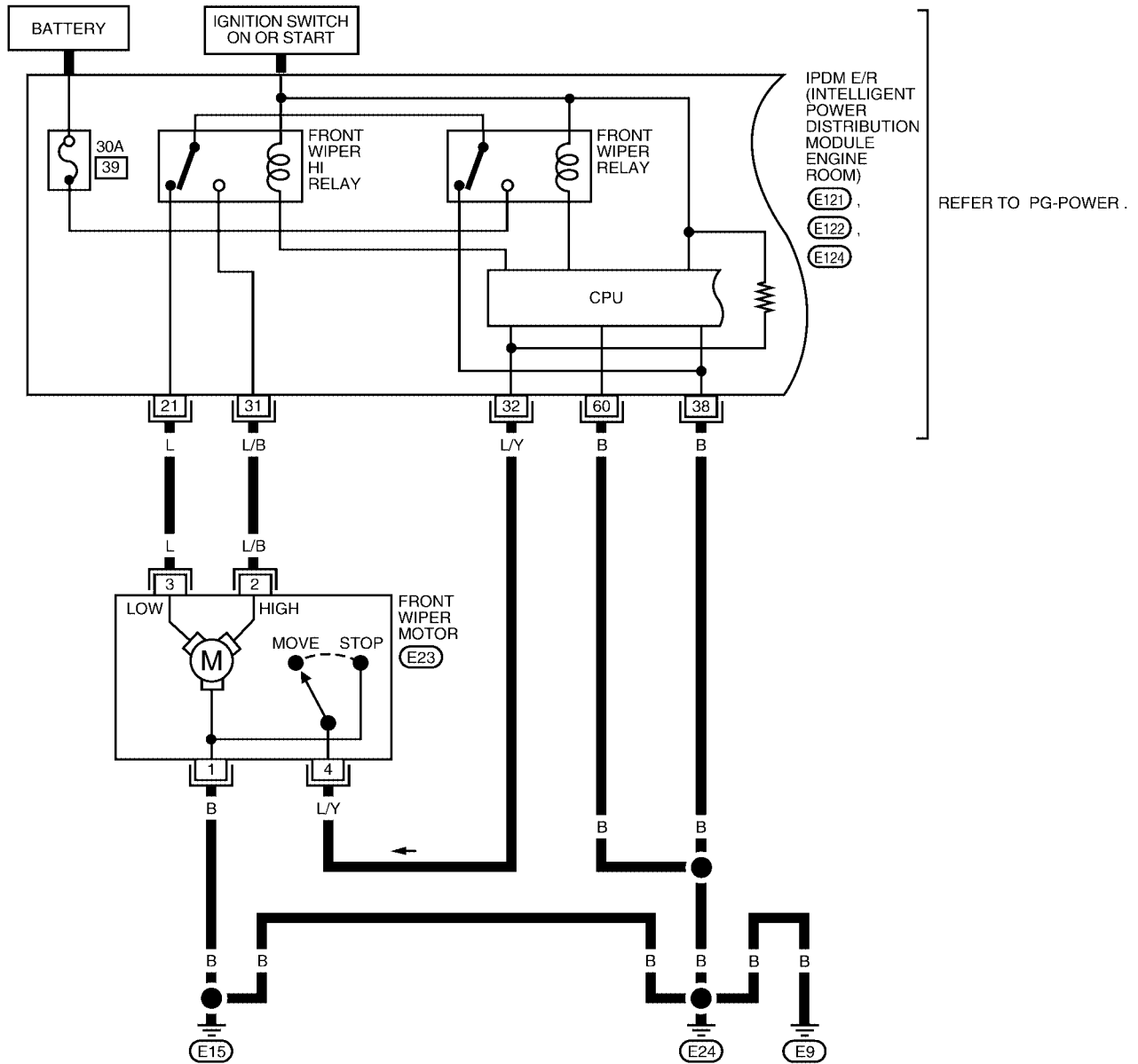

LKWA0249E

FRONT WIPER AND WASHER SYSTEM

WW-WIPER-02

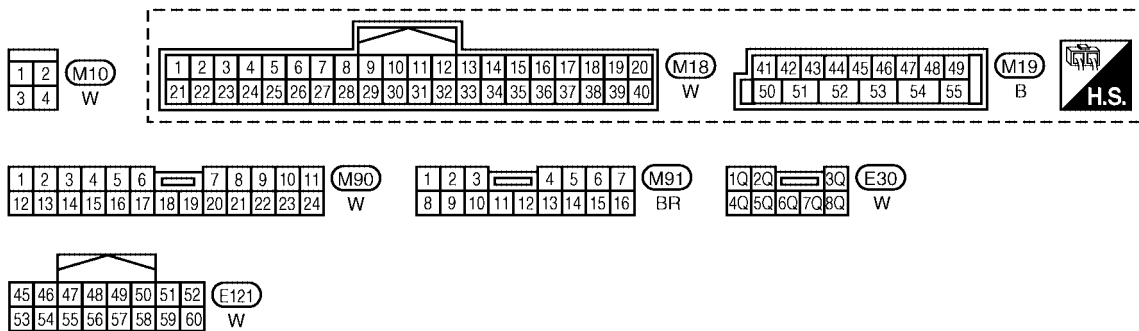
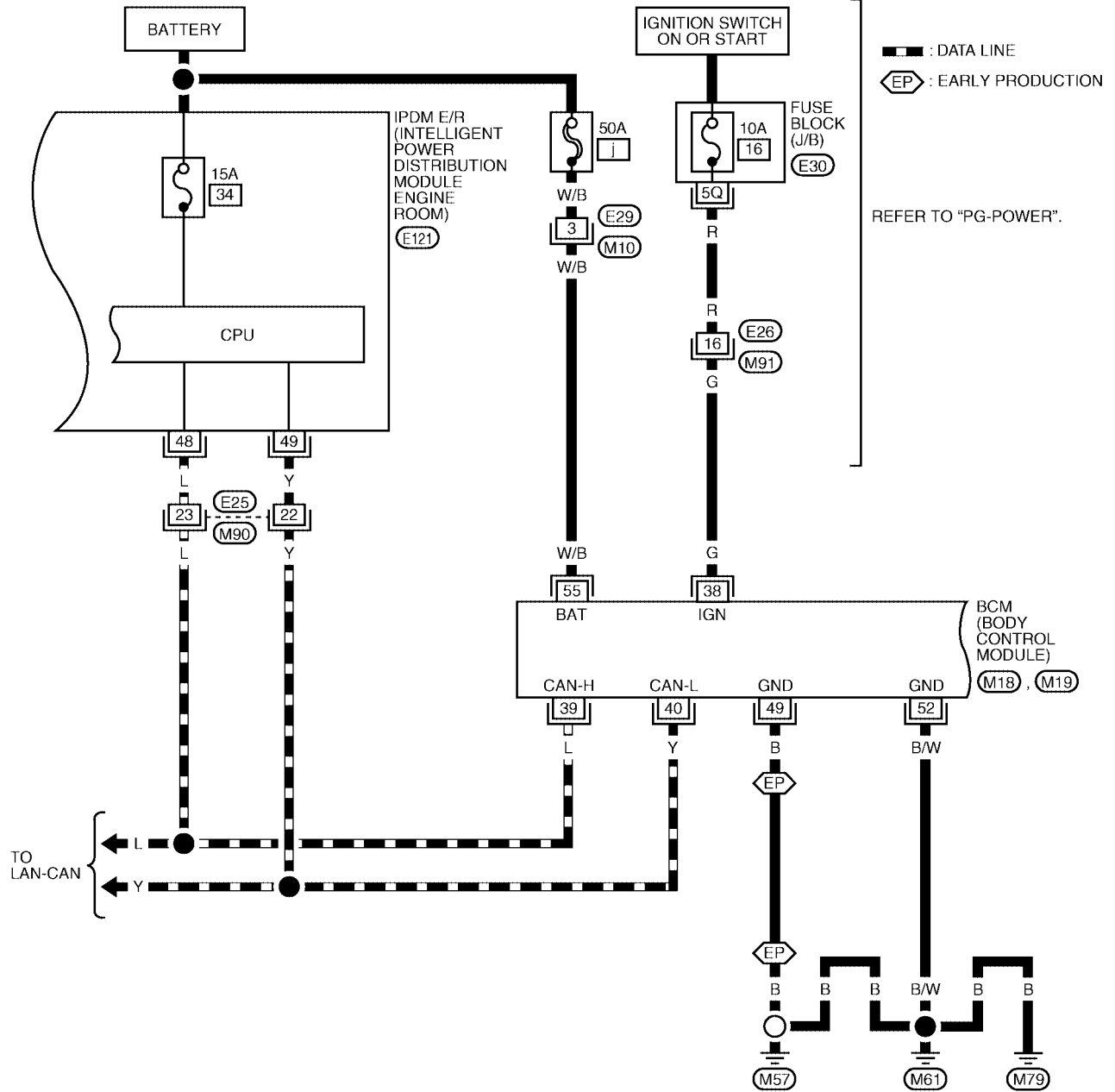

WKWA1644E

FRONT WIPER AND WASHER SYSTEM

WW-WIPER-03

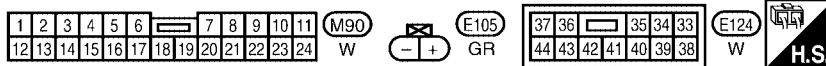
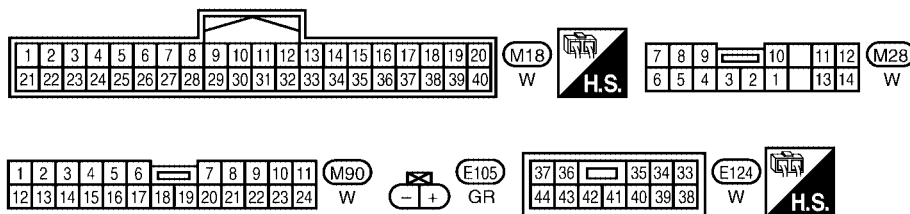
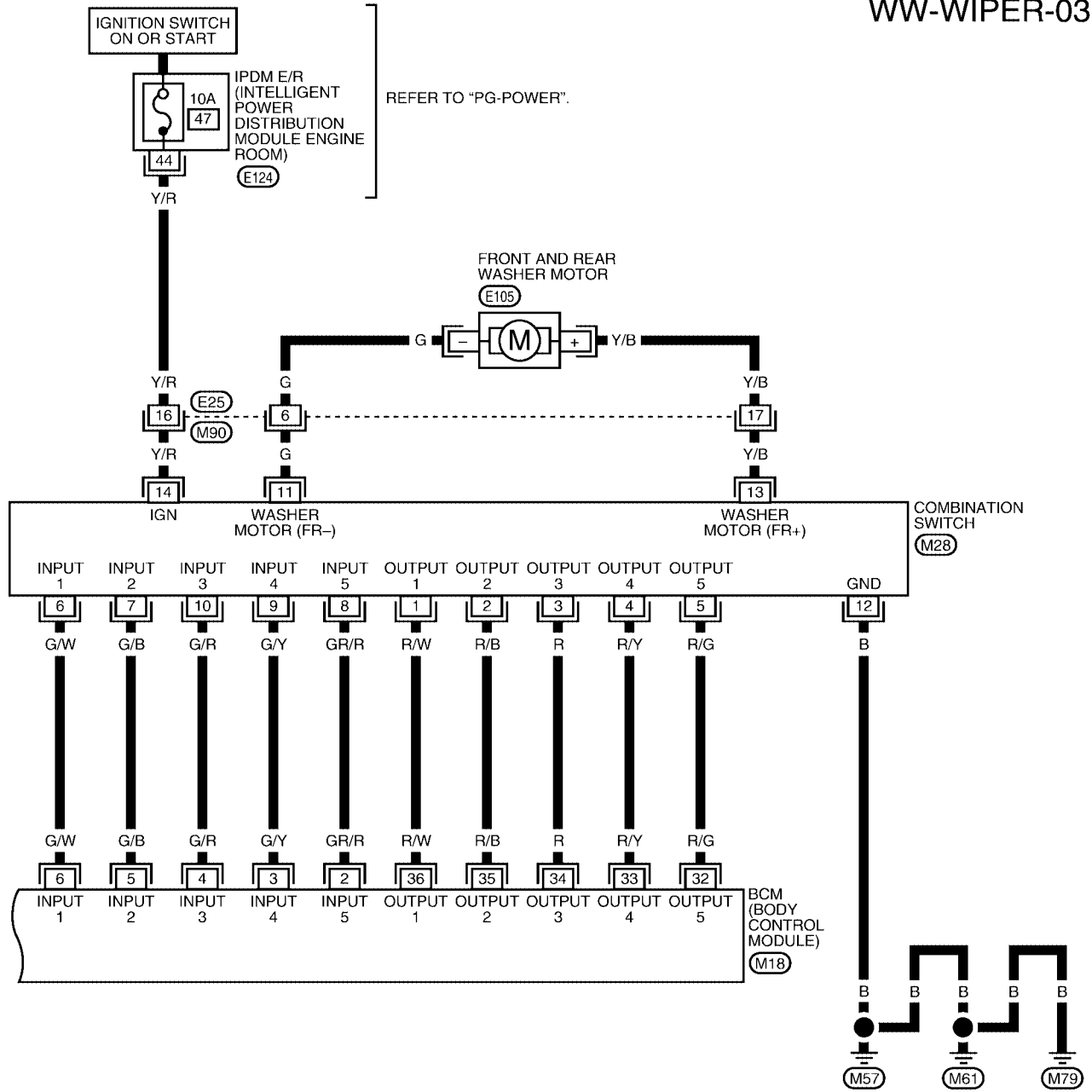

LKWA0250E

FRONT WIPER AND WASHER SYSTEM

Terminals and Reference Values for BCM

EKS005R1

Terminal No. (Wire color)	Signal name	Measuring condition		Reference Value (V) (Approx.)
		Ignition switch	Operation or condition	
2 (GR/R)	Combination switch input 5	ON	<ul style="list-style-type: none"> Light switch and wiper switch OFF Wiper dial position 4 	<p style="text-align: right;">SKIA5291E</p>
3 (G/Y)	Combination switch input 4	ON	<ul style="list-style-type: none"> Light switch and wiper switch OFF Wiper dial position 4 	<p style="text-align: right;">SKIA5292E</p>
4 (G/R)	Combination switch input 3	ON	<ul style="list-style-type: none"> Light switch and wiper switch OFF Wiper dial position 4 	<p style="text-align: right;">SKIA5291E</p>
5 (G/B)	Combination switch input 2	ON	<ul style="list-style-type: none"> Light switch and wiper switch OFF Wiper dial position 4 	<p style="text-align: right;">SKIA5292E</p>
6 (G/W)	Combination switch input 1	ON		
32 (R/G)	Combination switch output 5	ON	<ul style="list-style-type: none"> Light switch and wiper switch OFF Wiper dial position 4 	<p style="text-align: right;">SKIA5291E</p>
33 (R/Y)	Combination switch output 4	ON	<ul style="list-style-type: none"> Light switch and wiper switch OFF Wiper dial position 4 	<p style="text-align: right;">SKIA5292E</p>
34 (R)	Combination switch output 3	ON	<ul style="list-style-type: none"> Light switch and wiper switch OFF Wiper dial position 4 	<p style="text-align: right;">SKIA5291E</p>

A
B
C
D
E
F
G
H
I
J
L
M

WW

FRONT WIPER AND WASHER SYSTEM

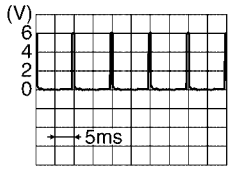
Terminal No. (Wire color)	Signal name	Measuring condition		Reference Value (V) (Approx.)
		Ignition switch	Operation or condition	
35 (R/B)	Combination switch output 2	ON	<ul style="list-style-type: none"> ● Light switch and wiper switch OFF ● Wiper dial position 4 	
36 (R/W)	Combination switch output 1			
38 (G)	Ignition switch (ON)	ON	—	Battery
39 (L)	CAN-H	ON	—	—
40 (Y)	CAN-L	ON	—	—
49 (B)*	Ground	—	—	0
52 (B/W)	Ground	—	—	0
55 (W/B)	Battery power	OFF	—	Battery

* Early production

Terminals and Reference Values for IPDM E/R

EKS005R2

Terminal No. (Wire color)	Signal name	Measuring condition		Reference value (V) (Approx.)	
		Ignition switch	Operation or condition		
21 (L)	Low speed signal	ON	Wiper switch	OFF	0
				LO	Battery
31 (L/B)	High speed signal	ON	Wiper switch	OFF	0
				HI	Battery
32 (L/Y)	Wiper auto - stop signal	ON	Wiper operating		Battery
			Wiper stopped		0
38 (B)	Ground	—	—	0	
44 (Y/R)	Combination switch power	ON	—	Battery	
48 (L)	CAN-H	ON	—	—	
49 (Y)	CAN-L	ON	—	—	
60 (B)	Ground	—	—	0	

Work Flow

EKS005R3

1. Confirm the symptom or customer complaint.
2. Understand the system description, refer to [WW-4, "System Description"](#) .
3. Perform preliminary inspection, refer to [WW-13, "Preliminary Inspection"](#) .
4. Check symptom and repair or replace the cause of the malfunction.
5. Does wiper function operate normally? If it operates normally, GO TO 6. If not, GO TO 4.
6. Inspection End.

FRONT WIPER AND WASHER SYSTEM

EKS005R4

Preliminary Inspection

INSPECTION FOR POWER SUPPLY AND GROUND CIRCUIT

Inspection procedure

1. CHECK FUSE

Check if wiper or washer fuse is blown.

Unit	Power source	Fuse No.
Front and rear washer motor	Ignition ON or START	47
Front wiper relay	Battery	39
BCM	Ignition ON or START	16
	Battery	j

OK or NG

OK >> GO TO 2.

NG >> If fuse is blown, be sure to eliminate cause of blown fuse before installing new fuse. Refer to [PG-4, "POWER SUPPLY ROUTING CIRCUIT"](#).

2. CHECK POWER SUPPLY CIRCUIT

- Disconnect BCM connectors.
- Check voltage between BCM harness connector terminals and ground.

Terminals		(-)	Ignition switch position	
(+)			OFF	ON
Connector	Terminal (Wire color)	Ground	0V	Battery voltage
M18	38 (G)		Battery voltage	Battery voltage
M19	55 (W/B)		Battery voltage	Battery voltage

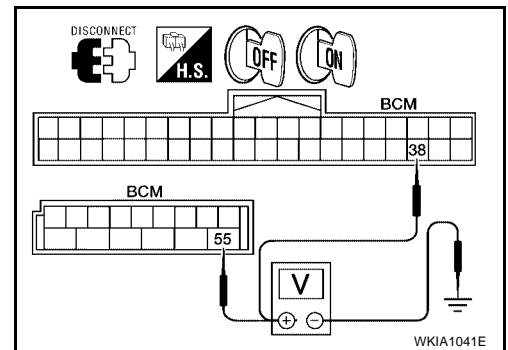

OK or NG

OK >> GO TO 3.

NG >> Check harness for open or short between BCM and fuse.

3. GROUND CIRCUIT INSPECTION (BCM)

Check for continuity between the following terminals on BCM connector and ground.

Terminals		Ignition switch condition	Continuity
Connector	Terminal (wire color)		
M19	49 (B)	OFF	Yes
	52 (B/W)		

* Early production

OK or NG

OK >> Inspection End.

NG >> Repair/replace BCM ground circuit.

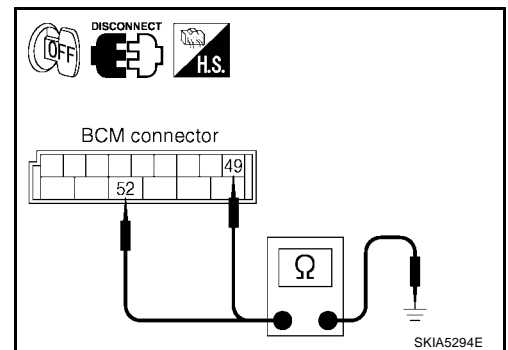

FRONT WIPER AND WASHER SYSTEM

CONSULT-II Function (BCM)

EKS005R5

CONSULT-II can display each diagnostic item using the diagnostic test modes shown following.

BCM diagnostic test item	Diagnostic mode	Description
Inspection by part	WORK SUPPORT	Supports inspections and adjustments. Commands are transmitted to the BCM for setting the status suitable for required operation, input/output signals are received from the BCM and received data is displayed.
	DATA MONITOR	Displays BCM input/output data in real time.
	ACTIVE TEST	Operation of electrical loads can be checked by sending drive signal to them.
	SELF-DIAG RESULTS	Displays BCM self-diagnosis results.
	CAN DIAG SUPPORT MNTR	The result of transmit/receive diagnosis of CAN communication can be read.
	ECU PART NUMBER	BCM part number can be read.
	CONFIGURATION	Performs BCM configuration read/write functions.

CONSULT-II OPERATION

CAUTION:

If CONSULT-II is used with no connection of CONSULT-II CONVERTER, malfunctions might be detected in self-diagnosis depending on control unit which carries out CAN communication.

1. With the ignition switch OFF, connect CONSULT-II and CONSULT-II CONVERTER to the data link connector, then turn the ignition switch ON.

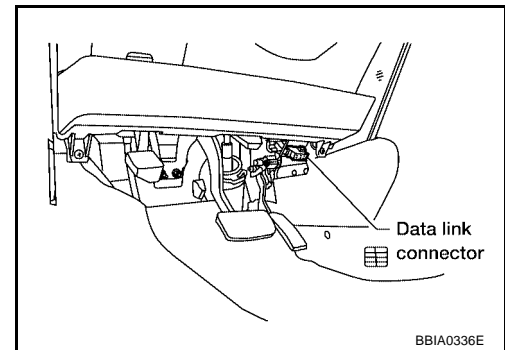

2. Touch "START (NISSAN BASED VHCL)".

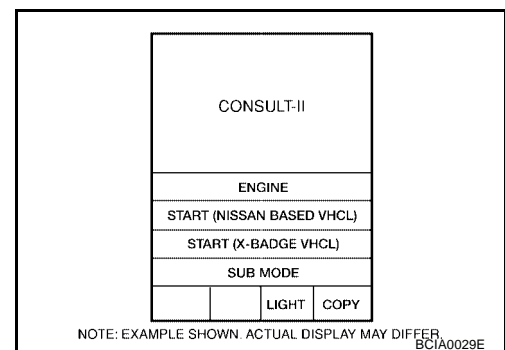

3. Touch "BCM" on the "SELECT SYSTEM" screen.
If "BCM" is not indicated, go to [GI-37, "CONSULT-II Data Link Connector \(DLC\) Circuit"](#).

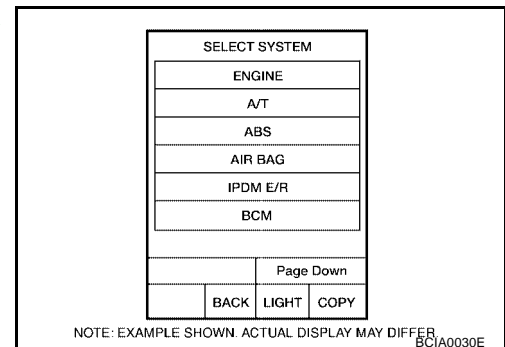

FRONT WIPER AND WASHER SYSTEM

4. Select the desired part to be diagnosed on the “SELECT TEST ITEM” screen.

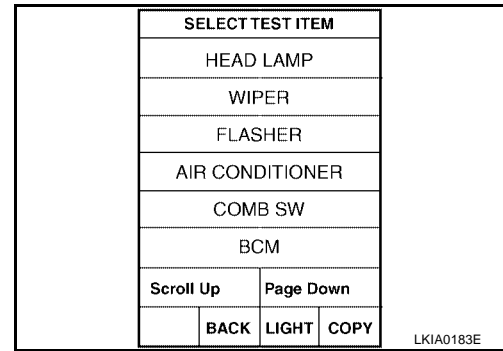

DATA MONITOR

Operation Procedure

1. Touch “WIPER” on the “SELECT TEST ITEM” screen.
2. Touch “DATA MONITOR” on the “SELECT DIAG MODE” screen.
3. Touch either “ALL SIGNALS” or “SELECTION FROM MENU” on the “SELECT MONITOR ITEM” screen.

ALL SIGNALS	Monitors all the items.
SELECTION FROM MENU	Selects and monitors the individual item selected.

4. Touch “START”.
5. When “SELECTION FROM MENU” is selected, touch items to be monitored. When “ALL SIGNALS” is selected, all the items will be monitored.
6. Touch “RECORD” while monitoring to record the status of the item being monitored. To stop recording, touch “STOP”.

Display Item List

Monitor item name “OPERATION OR UNIT”	Contents
IGN ON SW “ON/OFF”	Displays “IGN Position (ON)/OFF, ACC Position (OFF)” status as judged from ignition switch signal.
IGN SW CAN “ON/OFF”	Displays “IGN switch ON (ON)/Other OFF or ACC (OFF)” status as judged from CAN communications.
FR WIPER HI “ON/OFF”	Displays “Front Wiper HI (ON)/Other (OFF)” status as judged from wiper switch signal.
FR WIPER LOW “ON/OFF”	Displays “Front Wiper LOW (ON)/Other (OFF)” status as judged from wiper switch signal.
FR WIPER INT “ON/OFF”	Displays “Front Wiper INT (ON)/Other (OFF)” status as judged from wiper switch signal.
FR WASHER SW “ON/OFF”	Displays “Front Washer Switch (ON)/Other (OFF)” status as judged from wiper switch signal.
INT VOLUME (1 - 7)	Displays intermittent operation dial position setting (1 - 7) as judged from wiper switch signal.
FR WIPER STOP “ON/OFF”	Displays “Stopped (ON)/Operating (OFF)” status as judged from the auto-stop signal.
VEHICLE SPEED “0.0 km/h”	Displays vehicle speed as received from CAN communication.

ACTIVE TEST

Operation Procedure

1. Touch “WIPER” on the “SELECT TEST ITEM” screen.
2. Touch “ACTIVE TEST” on the “SELECT DIAG MODE” screen.
3. Touch item(s) to be tested and check operation of the selected item(s).
4. During the operation check, touching “BACK” deactivates the operation.

Display Item List

Test item	Display on CONSULT-II screen	Description
Front wiper HI output	FR WIPER (HI)	Front wiper HI can be operated by any ON-OFF operation.
Front wiper LO output	FR WIPER (LO)	Front wiper LO can be operated by any ON-OFF operation.
Front wiper INT output	FR WIPER (INT)	Front wiper INT can be operated by any ON-OFF operation.

FRONT WIPER AND WASHER SYSTEM

EKS005R6

CONSULT-II Function (IPDM E/R)

CONSULT-II can display each diagnostic item using the diagnostic test modes shown following.

IPDM E/R diagnostic Mode	Description
SELF-DIAG RESULTS	Displays IPDM E/R self-diagnosis results.
DATA MONITOR	Displays IPDM E/R input/output data in real time.
CAN DIAG SUPPORT MNTR	The result of transmit/receive diagnosis of CAN communication can be read.
ACTIVE TEST	Operation of electrical loads can be checked by sending drive signal to them.

CONSULT-II OPERATION

CAUTION:

If CONSULT-II is used with no connection of CONSULT-II CONVERTER, malfunctions might be detected in self-diagnosis depending on control unit which carries out CAN communication.

1. With the ignition switch OFF, connect CONSULT-II and CONSULT-II CONVERTER to the data link connector, then turn the ignition switch ON.

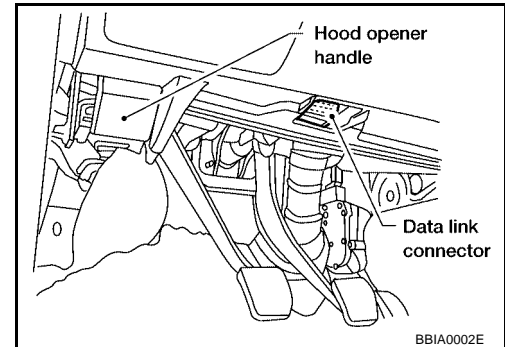

2. Touch "START (NISSAN BASED VHCL)".

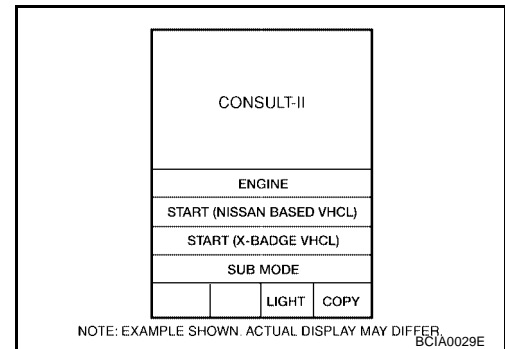

3. Touch "IPDM E/R" on "SELECT SYSTEM" screen. If "IPDM E/R" is not displayed, go to [GI-37, "CONSULT-II Data Link Connector \(DLC\) Circuit"](#).

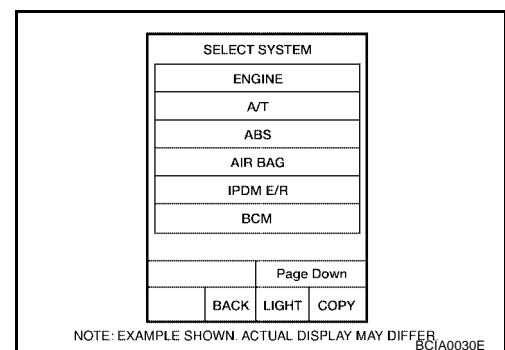

FRONT WIPER AND WASHER SYSTEM

4. Select the desired part to be diagnosed on the "SELECT DIAG MODE" screen.

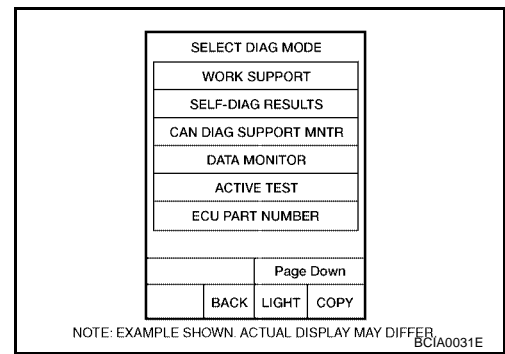

DATA MONITOR

Operation Procedure

1. Touch "DATA MONITOR" on the "SELECT DIAG MODE" screen.
2. Touch "ALL SIGNALS", "MAIN SIGNALS" or "SELECTION FROM MENU" on the "SELECT MONITOR ITEM" screen.

ALL SIGNALS	Monitors all the items.
MAIN SIGNALS	Monitors predetermined items.
SELECTION FROM MENU	Selects and monitors the individual item selected.

3. Touch "START".
4. When "SELECTION FROM MENU" is selected, touch items to be monitored. When "ALL SIGNALS" is selected, all the items will be monitored.
5. Touch "RECORD" while monitoring to record the status of the item being monitored. To stop recording, touch "STOP".

All Items, Main Items, Select Item Menu

Item name	CONSULT-II screen display	Display or unit	Monitor item selection			Description
			ALL SIGNALS	MAIN SIGNALS	SELECTION FROM MENU	
Front wiper request	FR WIP REQ	STOP/1LO/LO/HI	x	x	x	Signal status input from BCM.
Wiper auto stop	WIP AUTO STOP	ACT P/STOP P	x	x	x	Output status of IPDM E/R.
Wiper protection	WIP PROT	OFF/LS/HS/BLOCK	x	x	x	Control status of IPDM E/R.

NOTE:

Perform monitoring of IPDM E/R data with the ignition switch ON. When the ignition switch is at ACC, the display may not be correct.

ACTIVE TEST

Operation Procedure

1. Touch "ACTIVE TEST" on the "SELECT DIAG MODE" screen.
2. Touch item(s) to be tested and check operation of the selected item(s).
3. During the operation check, touching "BACK" deactivates the operation.

Display Item List

Test item	CONSULT-II screen display	Description
Front wiper (HI, LO) output	FRONT WIPER	With a certain operation (OFF, HI, LO) front wiper relays can be operated.

FRONT WIPER AND WASHER SYSTEM

EKS005R7

Trouble Diagnosis FRONT WIPER DOES NOT OPERATE

CAUTION:

During IPDM E/R fail-safe control, front wipers may not operate. Refer to [PG-15, "CAN COMMUNICATION LINE CONTROL"](#) to make sure that it is not in fail-safe status.

Inspection Procedure

1. CHECK IPDM E/R TO FRONT WIPERS

Ⓟ With CONSULT-II

1. Select "IPDM E/R" with CONSULT-II, and select "ACTIVE TEST" on "SELECT DIAG MODE" screen.
2. Select "FRONT WIPER" on "SELECT TEST ITEM" screen.

ⓧ Without CONSULT-II

1. Turn on front wipers using auto active test. Refer to [PG-21, "Auto Active Test"](#).
2. Confirm front wiper operation.

OK or NG

- OK >> GO TO 4.
NG >> GO TO 2.

ACTIVE TEST			
FRONT WIPER		OFF	
HI		LO	
MODE	BACK	LIGHT	COPY

SKIA3486E

FRONT WIPER AND WASHER SYSTEM

2. IPDM E/R TO FRONT WIPERS CIRCUIT INSPECTION

1. Turn ignition switch OFF.
2. Disconnect IPDM E/R connector and front wiper motor connector.
3. Check continuity between IPDM E/R harness connector terminals and front wiper motor harness connector terminals.

Terminals				Continuity
Connector	Terminal (wire color)	Connector	Terminal (wire color)	
E122	31 (L/B)	E23	2 (L/B)	Yes
	21 (L)		3 (L)	
	32 (L/Y)		4 (L/Y)	

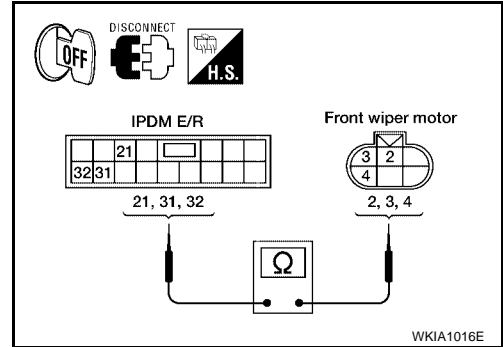

4. Check continuity between IPDM E/R harness connector terminals and ground.

Terminals				Continuity
Connector	Terminal (wire color)			
E122	31 (L/B)	Ground		No
	21 (L)			
	32 (L/Y)			

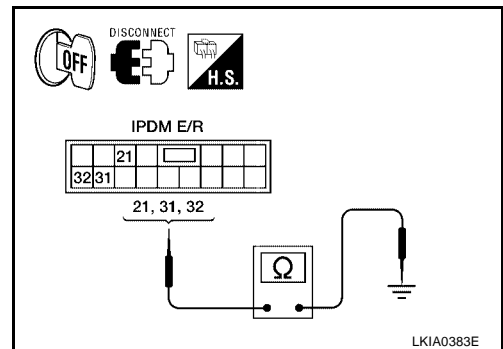

5. Check continuity between IPDM E/R harness connector terminal and ground.

Terminals				Continuity
Connector	Terminal (wire color)			
E121	60 (B)	Ground		Yes
E124	38 (B)			

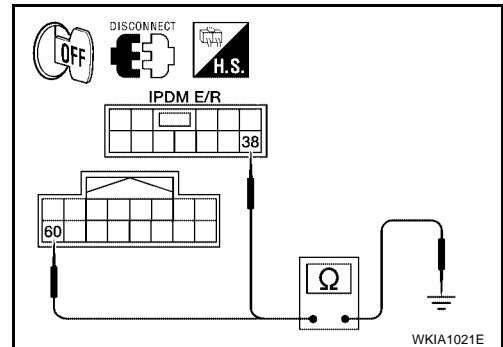

6. Check continuity between front wiper motor harness connector terminal 1 and ground.

Terminals				Continuity
Connector	Terminal (wire color)			
E23	1 (B)	Ground		Yes

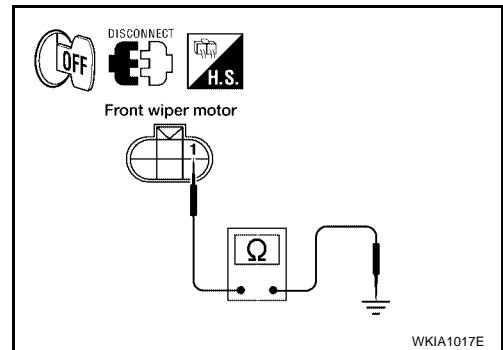

OK or NG

- OK >> GO TO 3.
- NG >> Check for open circuit in harness between front wiper motor and ground.

FRONT WIPER AND WASHER SYSTEM

3. IPDM E/R INSPECTION

Ⓜ With CONSULT-II

1. Connect IPDM E/R connector and front wiper motor connector.
2. Select "HI" during "ACTIVE TEST".
3. When front wiper relay, and front wiper high relay are operating, check voltage between IPDM E/R terminals and ground.

ⓧ Without CONSULT-II

1. Connect IPDM E/R connector and front wiper motor connector.
2. Turn on front wipers using the auto active test. Refer to [PG-21, "Auto Active Test"](#) .
3. When front wiper relay, and front wiper high relay are operating, check voltage between IPDM E/R terminals and ground.

Terminals			Condition	Voltage (Approx.)
(+)		(-)		
Connector	Terminal (wire color)			
E122	21 (L)	Ground	Stopped	0
			LO operation	Battery voltage
	31 (L/B)		Stopped	0
			HI operation	Battery voltage

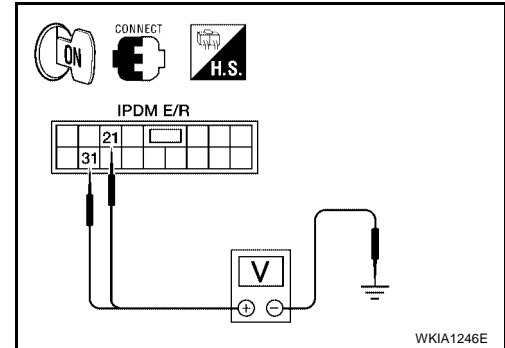

OK or NG

- OK >> Replace the front wiper motor. Refer to [WW-27, "Removal and Installation of Wiper Motor and Linkage"](#) .
- NG >> Replace IPDM E/R. Refer to [PG-27, "Removal and Installation of IPDM E/R"](#) .

4. COMBINATION SWITCH TO BCM INSPECTION

Select "BCM" on CONSULT-II. With "WIPER" data monitor, check that "FR WIPER INT", "FR WIPER LOW" and "FR WIPER HI" turn ON-OFF according to operation of wiper switch.

OK or NG

- OK >> GO TO 5.
- NG >> Check wiper switch. Refer to [BCS-3, "COMBINATION SWITCH READING FUNCTION"](#) .

DATA MONITOR			
MONITOR			
IGN ON SW		OFF	
IGN SW CAN		ON	
FR WIPER HI		OFF	
FR WIPER LOW		OFF	
FR WIPER INT		OFF	
FR WASHER SW		OFF	
INT VOLUME		7	
FR WIPER STOP		ON	
VEHICLE SPEED		0.0 km/h	
		PAGE DOWN	
		RECORD	
MODE	BACK	LIGHT	COPY

WKIA1018E

5. BCM INSPECTION

Select "BCM" on CONSULT-II. Carry out self-diagnosis of BCM.

Displayed self-diagnosis results

- NO DTC>> Replace the BCM. Refer to [BCS-19, "Removal and Installation of BCM"](#) .
- CAN COMM CIRCUIT>> Check CAN communication line of BCM. GO TO [BCS-13, "CAN Communication Inspection Using CONSULT-II \(Self-Diagnosis\)"](#) .

SELF-DIAG RESULTS			
DTC RESULTS		TIME	
CAN COMM CIRCUIT [U1000]		PAST	
ERASE		PRINT	
MODE	BACK	LIGHT	COPY

SKIA1039E

FRONT WIPER AND WASHER SYSTEM

FRONT WIPER STOP POSITION IS INCORRECT

Inspection Procedure

1. CHECK IPDM E/R TO FRONT WIPER MOTOR

Ⓔ With CONSULT-II

Select "IPDM E/R" with CONSULT-II. With data monitor, confirm that "WIP AUTO STOP" changes from "ACT P" to "STOP P" according to wiper operation.

ⓧ Without CONSULT-II

GO TO 2.

OK or NG

OK >> Replace IPDM E/R. Refer to [PG-27, "Removal and Installation of IPDM E/R"](#).

NG >> GO TO 2.

DATA MONITOR	
MONITOR	
MOTOR FAN REQ	1
AC COMP REQ	OFF
TAIL&CLR REQ	OFF
HL LO REQ	OFF
HL HI REQ	OFF
FR FOG REQ	OFF
FR WIP REQ	STOP
WIP AUTO STOP	STOP P
WIP PROT	OFF
Page DOWN	
RECORD	
MODE	BACK
LIGHT	COPY

SKIA5301E

2. IPDM E/R TO FRONT WIPER MOTOR CIRCUIT INSPECTION

1. Turn ignition switch OFF.
2. Disconnect IPDM E/R connector and front wiper motor connector.
3. Check continuity between IPDM E/R harness connector and front wiper motor harness connector.

Terminals				Continuity
Connector	Terminal (wire color)	Connector	Terminal (wire color)	
E122	32 (L/Y)	E23	4 (L/Y)	Yes

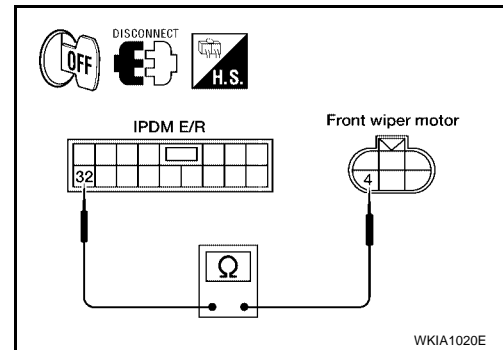

4. Check continuity between IPDM E/R harness connector terminal and ground.

Terminals			Continuity
Connector	Terminal (wire color)	Ground	
E122	32 (L/Y)	Ground	No

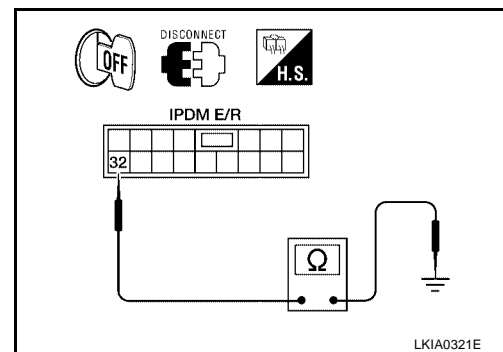

5. Check continuity between front wiper motor harness connector terminal 1 and ground.

Terminals			Continuity
Connector	Terminal (wire color)	Ground	
E23	1 (B)	Ground	Yes

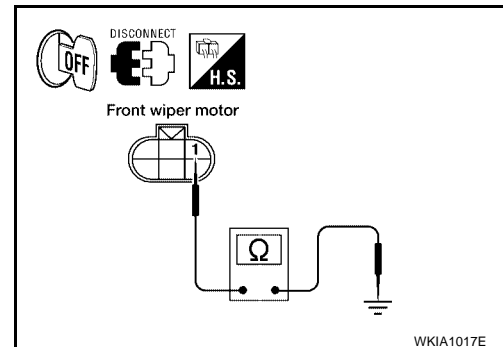

OK or NG

OK >> Connect connectors. GO TO 3.

NG >> ● Check for short circuit or open circuit in harness between IPDM E/R and front wiper motor.

- Check for open circuit in harness between front wiper motor and ground.

FRONT WIPER AND WASHER SYSTEM

3. IPDM E/R INSPECTION

While front wiper motor is stopped and while operating, measure voltage between IPDM E/R terminal 32 and ground.

Terminals		(-)	Condition	Voltage (Approx.)
(+) Connector				
Terminal (wire color)				
E122	32 (L/Y)	Ground	Wiper operating	Fluctuating
			Wiper stopped	0V

OK or NG

OK >> Replace IPDM E/R. Refer to [PG-27, "Removal and Installation of IPDM E/R"](#).

NG >> Replace front wiper motor. Refer to [WW-27, "Removal and Installation of Wiper Motor and Linkage"](#).

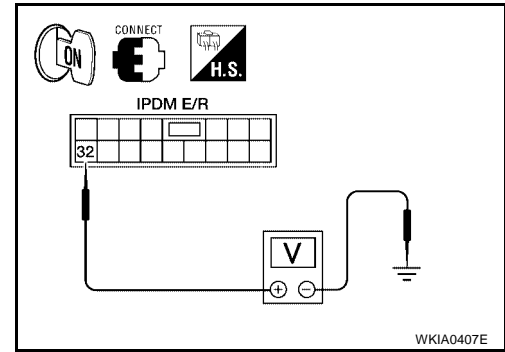

ONLY FRONT WIPER LOW DOES NOT OPERATE

Inspection Procedure

1. COMBINATION SWITCH TO BCM INSPECTION

Select "BCM" on CONSULT-II. With "WIPER" data monitor, check that "FR WIPER LOW" turns ON-OFF according to operation of wiper switch.

OK or NG

OK >> Replace BCM. Refer to [BCS-19, "Removal and Installation of BCM"](#).

NG >> Replace wiper switch. Refer to [WW-28, "Removal and Installation of Wiper and Washer Switch"](#).

DATA MONITOR	
MONITOR	
IGN ON SW	OFF
IGN SW CAN	ON
FR WIPER HI	OFF
FR WIPER LOW	OFF
FR WIPER INT	OFF
FR WASHER SW	OFF
INT VOLUME	7
FR WIPER STOP	ON
VEHICLE SPEED	0.0 km/h
PAGE DOWN	
RECORD	
MODE	BACK
LIGHT	COPY

ONLY FRONT WIPER HI DOES NOT OPERATE

Inspection Procedure

1. CHECK IPDM E/R TO FRONT WIPERS

Ⓟ With CONSULT-II

- Select "IPDM E/R" with CONSULT-II, and select "ACTIVE TEST" on "SELECT DIAG MODE" screen.
- Select "FRONT WIPER" on "SELECT TEST ITEM" screen.

ⓧ Without CONSULT-II

- Turn on front wipers using auto active test. Refer to [PG-21, "Auto Active Test"](#).
- Confirm front wiper operation.

OK or NG

OK >> GO TO 4.

NG >> GO TO 2.

ACTIVE TEST	
FRONT WIPER	OFF
HI	
LO	
MODE	
BACK	LIGHT
COPY	

FRONT WIPER AND WASHER SYSTEM

2. IPDM E/R TO FRONT WIPERS CIRCUIT INSPECTION

1. Turn ignition switch OFF.
2. Disconnect IPDM E/R connector and front wiper motor connector.
3. Check continuity between IPDM E/R harness connector terminal and front wiper motor harness connector terminal.

Terminals				Continuity
Connector	Terminal (wire color)	Connector	Terminal (wire color)	
E122	31 (L/B)	E23	2 (L/B)	Yes

OK or NG

OK >> GO TO 3.

NG >> Check for short circuit or open circuit in harness between IPDM E/R and front wiper motor.

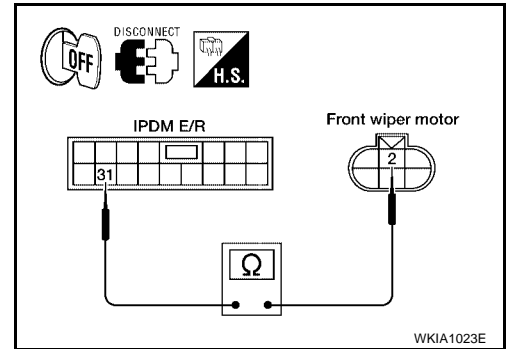

3. IPDM E/R INSPECTION

With CONSULT-II

1. Connect IPDM E/R connector and front wiper motor connector.
2. Select "HI" during "ACTIVE TEST".
3. When front wiper high relay is operating, check voltage between IPDM E/R terminals.

Without CONSULT-II

1. Connect IPDM E/R connector and front wiper motor connector.
2. Turn on front wipers using the auto active test. Refer to [PG-21, "Auto Active Test"](#).
3. When front wiper high relay is operating, check voltage between IPDM E/R terminals.

IPDM E/R Terminals				Voltage (Approx.)
(+)		(-)		
Connector	Terminal (wire color)	Connector	Terminal (wire color)	
E122	31 (L/B)	E124	38 (B)	Battery voltage
		E121	60 (B)	

OK or NG

OK >> Replace the wiper motor. Refer to [WW-27, "Removal and Installation of Wiper Motor and Linkage"](#)

NG >> Replace IPDM E/R. Refer to [PG-27, "Removal and Installation of IPDM E/R"](#).

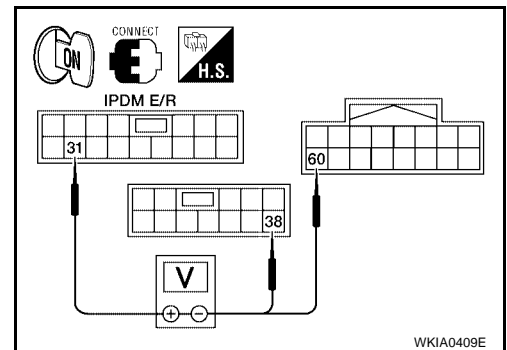

4. COMBINATION SWITCH TO BCM INSPECTION

Select "BCM" on CONSULT-II. With "WIPER" data monitor, check that "FR WIPER HI" turns ON-OFF according to operation of wiper switch.

OK or NG

OK >> Replace BCM. Refer to [BCS-19, "Removal and Installation of BCM"](#).

NG >> Replace wiper switch. Refer to [WW-28, "Removal and Installation of Wiper and Washer Switch"](#).

DATA MONITOR			
MONITOR			
IGN ON SW		OFF	
IGN SW CAN		ON	
FR WIPER HI		OFF	
FR WIPER LOW		OFF	
FR WIPER INT		OFF	
FR WASHER SW		OFF	
INT VOLUME		7	
FR WIPER STOP		ON	
VEHICLE SPEED		0.0 km/h	
PAGE DOWN			
RECORD			
MODE	BACK	LIGHT	COPY

FRONT WIPER AND WASHER SYSTEM

ONLY FRONT WIPER INT DOES NOT OPERATE

Inspection Procedure

1. COMBINATION SWITCH TO BCM INSPECTION

Select "BCM" on CONSULT-II. With "WIPER" data monitor, check that "FR WIPER INT" turns ON-OFF according to operation of wiper switch.

OK or NG

- OK >> Replace BCM. Refer to [BCS-19, "Removal and Installation of BCM"](#).
- NG >> Replace wiper switch. Refer to [WW-28, "Removal and Installation of Wiper and Washer Switch"](#).

DATA MONITOR			
MONITOR			
IGN ON SW		OFF	
IGN SW CAN		ON	
FR WIPER HI		OFF	
FR WIPER LOW		OFF	
FR WIPER INT		OFF	
FR WASHER SW		OFF	
INT VOLUME		7	
FR WIPER STOP		ON	
VEHICLE SPEED		0.0 km/h	
		PAGE DOWN	
RECORD			
MODE	BACK	LIGHT	COPY

WKIA1018E

FRONT WIPER INTERMITTENT OPERATION SWITCH POSITION CANNOT BE ADJUSTED

Inspection Procedure

1. COMBINATION SWITCH TO BCM INSPECTION

Select "BCM" on CONSULT-II. With "WIPER" data monitor, check that "INT VOLUME" changes in order from 1 to 7 according to operation of the intermittent switch dial position.

OK or NG

- OK >> Replace BCM. Refer to [BCS-19, "Removal and Installation of BCM"](#).
- NG >> Replace wiper switch. Refer to [WW-28, "Removal and Installation of Wiper and Washer Switch"](#).

DATA MONITOR			
MONITOR			
IGN ON SW		OFF	
IGN SW CAN		ON	
FR WIPER HI		OFF	
FR WIPER LOW		OFF	
FR WIPER INT		OFF	
FR WASHER SW		OFF	
INT VOLUME		7	
FR WIPER STOP		ON	
VEHICLE SPEED		0.0 km/h	
		PAGE DOWN	
RECORD			
MODE	BACK	LIGHT	COPY

WKIA1018E

WIPERS DO NOT WIPE WHEN FRONT WASHER OPERATES

Inspection Procedure

1. COMBINATION SWITCH TO BCM INSPECTION

Select "BCM" on CONSULT-II. With "WIPER" data monitor, check that "FR WASHER SW" turns ON-OFF according to operation of front washer switch.

OK or NG

- OK >> Replace BCM. Refer to [BCS-19, "Removal and Installation of BCM"](#).
- NG >> Replace wiper switch. Refer to [WW-28, "Removal and Installation of Wiper and Washer Switch"](#).

DATA MONITOR			
MONITOR			
IGN ON SW		OFF	
IGN SW CAN		ON	
FR WIPER HI		OFF	
FR WIPER LOW		OFF	
FR WIPER INT		OFF	
FR WASHER SW		OFF	
INT VOLUME		7	
FR WIPER STOP		ON	
VEHICLE SPEED		0.0 km/h	
		PAGE DOWN	
RECORD			
MODE	BACK	LIGHT	COPY

WKIA1018E

FRONT WIPERS OPERATE FOR 10 SECONDS, STOP FOR 20 SECONDS, AND AFTER REPEATING THIS OPERATION FIVE TIMES, THEY BECOME INOPERATIVE

CAUTION:

- When auto stop signal has not varied for 10 seconds or longer while IPDM E/R is operating front wipers, IPDM E/R considers front wipers locked and stops wiper output, which causes this symptom.
- This status can be checked by using IPDM E/R "DATA MONITOR". Under this condition, "WIP PROT" reads "BLOCK".

FRONT WIPER AND WASHER SYSTEM

Inspection Procedure

1. CHECK IPDM E/R TO FRONT WIPER MOTOR

Ⓟ With CONSULT-II

Select "IPDM E/R" with CONSULT-II. With data monitor, confirm that "WIP AUTO STOP" changes from "ACT P" to "STOP P" according to wiper operation.

ⓧ Without CONSULT-II

GO TO 2.

OK or NG

OK >> Replace IPDM E/R. Refer to [PG-27, "Removal and Installation of IPDM E/R"](#).

NG >> GO TO 2.

DATA MONITOR	
MONITOR	
MOTOR FAN REQ	1
AC COMP REQ	OFF
TAIL&CLR REQ	OFF
HL LO REQ	OFF
HL HI REQ	OFF
FR FOG REQ	OFF
FR WIP REQ	STOP
WIP AUTO STOP	STOP P
WIP PROT	OFF
Page DOWN	
RECORD	
MODE	BACK
LIGHT	COPY

SKIA5301E

2. IPDM E/R TO FRONT WIPER MOTOR CIRCUIT CONTINUITY INSPECTION

1. Turn ignition switch OFF.
2. Disconnect IPDM E/R connector and front wiper motor connector.
3. Check continuity between IPDM E/R harness connector terminal and front wiper motor harness connector terminal.

Terminals				Continuity
Connector	Terminal (wire color)	Connector	Terminal (wire color)	
E122	32 (L/Y)	E23	4 (L/Y)	Yes

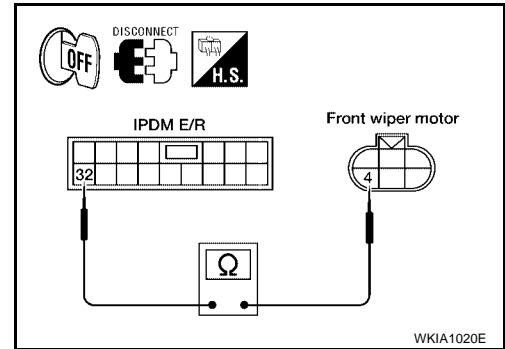

4. Check continuity between IPDM E/R harness connector terminal and ground.

Terminals			Continuity
Connector	Terminal (wire color)		
E122	32 (L/Y)	Ground	No

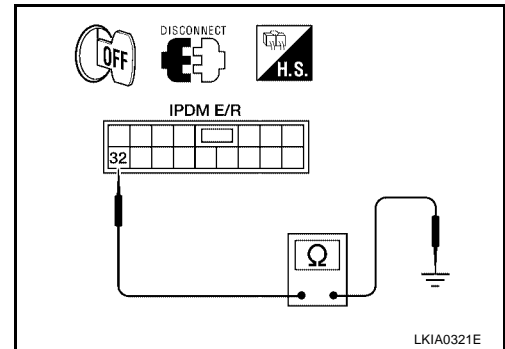

OK or NG

OK >> Connect connectors. GO TO 3.

NG >> Repair harness or connector.

FRONT WIPER AND WASHER SYSTEM

3. IPDM E/R TO FRONT WIPER MOTOR AUTO STOP CIRCUIT INSPECTION

While front wiper motor is stopped and while operating, measure voltage between IPDM E/R terminal 32 and ground.

Terminals		(-)	Condition	Voltage (Approx.)
(+) Connector				
Terminal (wire color)				
E122	32 (L/Y)	Ground	Wiper operating	Fluctuating
			Wiper stopped	0V

OK or NG

OK >> Replace IPDM E/R. Refer to [PG-27, "Removal and Installation of IPDM E/R"](#).

NG >> Replace front wiper motor. Refer to [WW-27, "Removal and Installation of Wiper Motor and Linkage"](#).

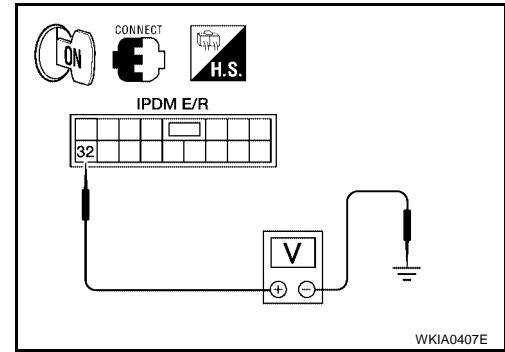

Removal and Installation of Front Wiper Arms, Adjustment of Wiper Arms Stop Location

EKS005R8

REMOVAL

1. Operate front wiper motor one full cycle, then turn "OFF" (Auto Stop).
2. Remove wiper arm covers and mounting nuts, then lift wiper arms off pivots.

ADJUSTMENT

1. Prior to front wiper arm installation or adjustment:
 - Operate front wiper motor one full cycle, then turn "OFF" (Auto Stop).
 - Using a suitable brush, clean pivot area as illustrated. This will reduce the possibility of wiper arm looseness.

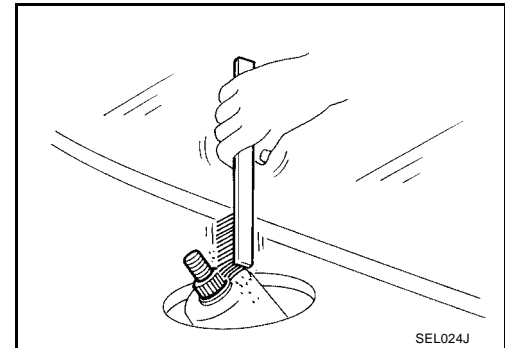

2. Lift the wiper blade up, then rest it onto glass surface to set clearance "L1" and "L2" as illustrated.

Clearance "L1" : 41.5 - 56.5 mm (1.634 - 2.224 in)

Clearance "L2" : 52.5 - 67.5 mm (2.067 - 2.657 in)

3. Tighten wiper arm mounting nuts to specified torque.

Front wiper arm mounting nuts : 23.6 N-m (2.4 kg-m, 17 ft-lb)

4. Eject washer fluid and operate front wiper motor several cycles, then turn "OFF" (Auto Stop).
5. At the stop location (Auto Stop), ensure wiper blades are within clearance "L1" and "L2" as illustrated.

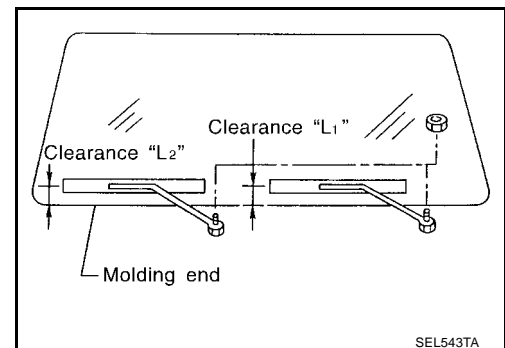

INSTALLATION

1. Operate front wiper motor one full cycle, then turn "OFF" (Auto Stop).
2. Install wiper arms and mounting nuts onto pivots and tighten to specified torque.
3. Install wiper arm covers, then check and adjust clearance "L1" and "L2" as necessary to ensure proper blade overlap.

FRONT WIPER AND WASHER SYSTEM

Removal and Installation of Wiper Motor and Linkage

EKS005R9

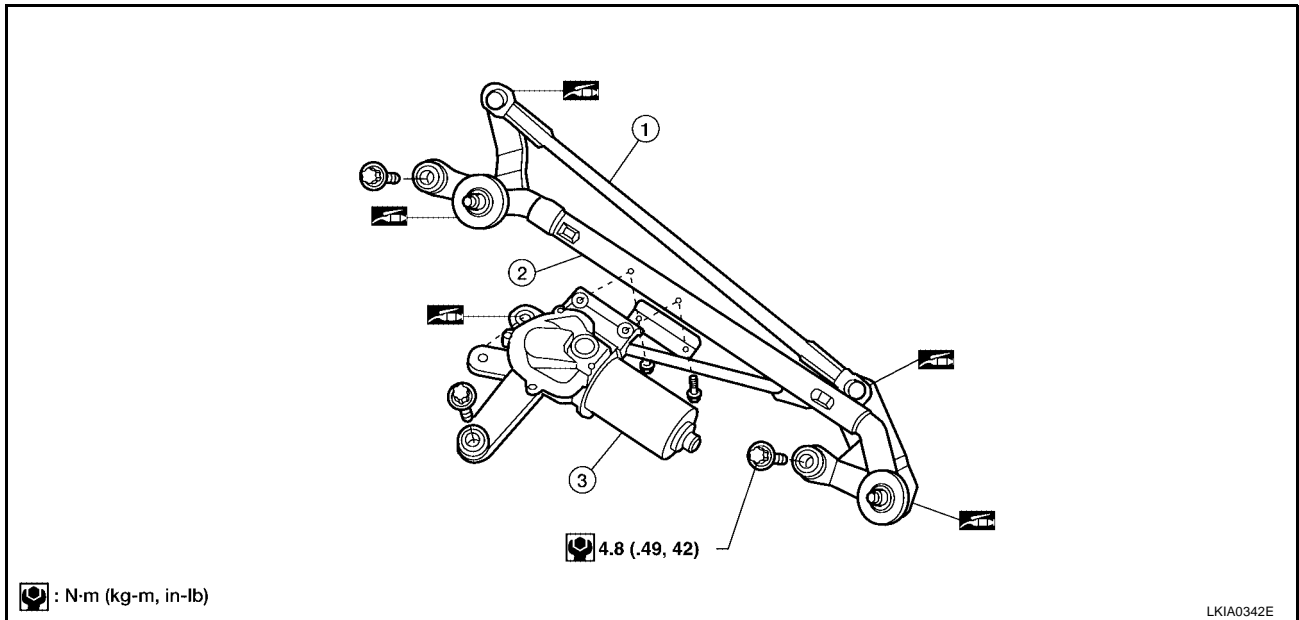

1. Wiper link

2. Wiper frame

3. Front wiper motor

REMOVAL

1. Operate the wiper motor, and stop it at the auto stop position.
2. Remove wiper arms from the vehicle. Refer to [WW-26, "Removal and Installation of Front Wiper Arms, Adjustment of Wiper Arms Stop Location"](#).
3. Remove the cowl top extension. Refer to [EI-18, "Removal and Installation"](#).
4. Disconnect wiper motor connector.
5. Remove wiper frame assembly mounting bolts, and remove wiper frame assembly.
6. Remove wiper motor from wiper frame assembly.

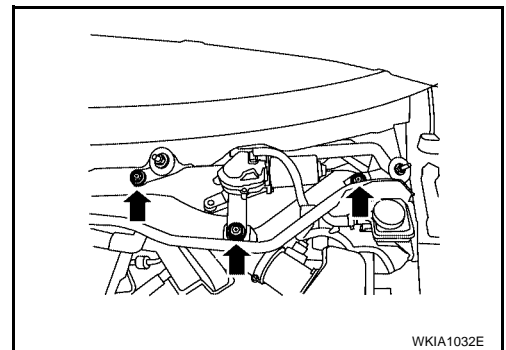

INSTALLATION

CAUTION:

- Do not drop the wiper motor or cause it to contact other parts.
 - Check the grease conditions of the motor arm and wiper link joint(s). Apply grease if necessary.
1. Connect wiper motor to connector. Turn the wiper switch ON to operate wiper motor, then turn the wiper switch OFF (auto stop).
 2. Disconnect wiper motor connector.
 3. Install wiper motor to wiper frame assembly, and install assembly into the vehicle.
 4. Connect wiper motor connector. Turn the wiper switch ON to operate the wiper motor, then turn wiper switch OFF (auto stop).
 5. Install cowl top extension. Refer to [EI-18, "Removal and Installation"](#).
 6. Install wiper arms. Refer to [WW-26, "Removal and Installation of Front Wiper Arms, Adjustment of Wiper Arms Stop Location"](#).

FRONT WIPER AND WASHER SYSTEM

Washer Nozzle Adjustment

EKS005RA

- This vehicle is equipped with non-adjustable washer nozzles.
- If not satisfied with washer fluid spray coverage, confirm that the washer nozzle is installed correctly.
- If the washer nozzle is installed correctly, and the washer fluid spray coverage is not satisfactory, replace washer nozzle.

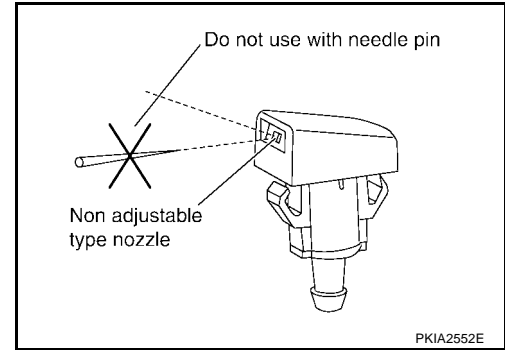

Washer Tube Layout

EKS005RB

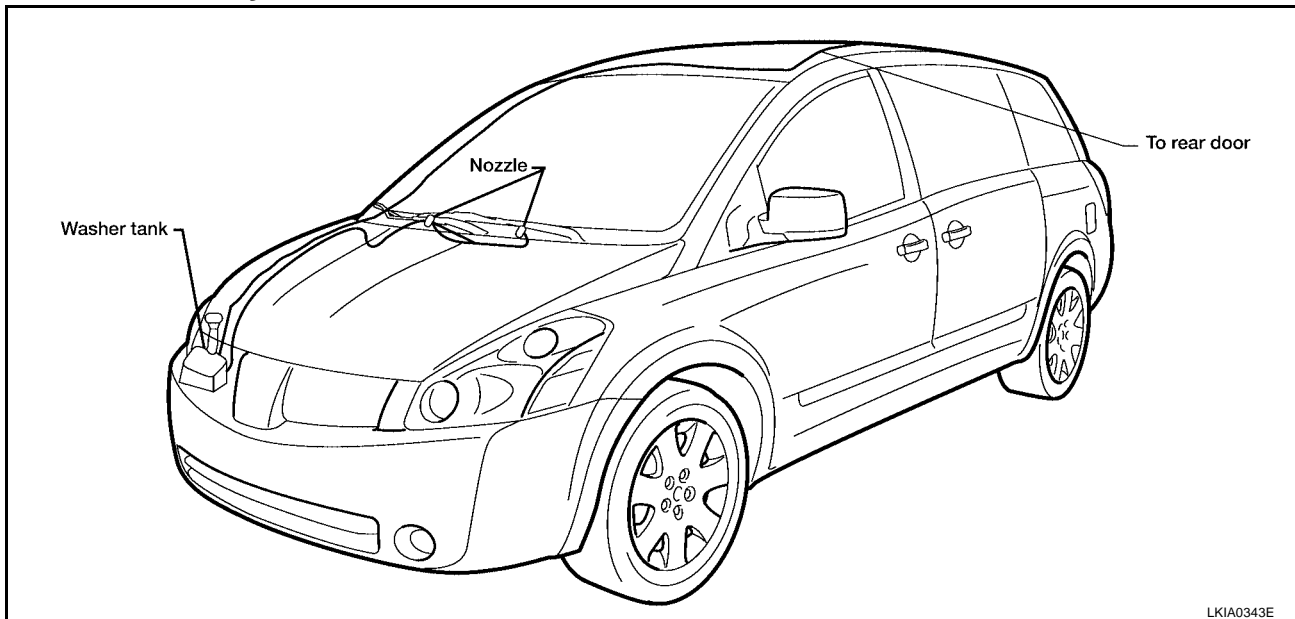

Removal and Installation of Wiper and Washer Switch

EKS005RC

REMOVAL

1. Remove steering column covers.
2. Remove wiper washer switch connector.
3. Pinch tabs at wiper and washer switch base and slide switch away from steering column to remove.

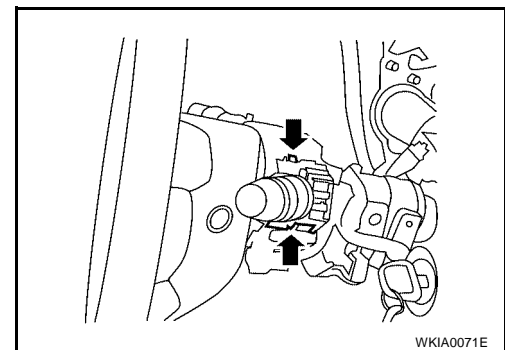

INSTALLATION

Installation is in the reverse order of removal.

FRONT WIPER AND WASHER SYSTEM

Removal and Installation of Washer Tank

EKS005RD

1. Pull out washer tank inlet.
2. Remove fender protector. Refer to [EI-21, "Removal and Installation"](#) .
3. Remove front and rear washer motor connector and washer fluid level sensor connector.
4. Remove washer tank screws.
5. Remove front and rear washer hoses, and remove the washer tank from the vehicle.

CAUTION:

After installation, add water up to the upper level of the washer tank inlet, and check for water leaks.

Installation is in the reverse order of removal.

Washer tank installation screw

Tightening torque: 5.5 N·m (0.56 kg·m, 49 in·lb)

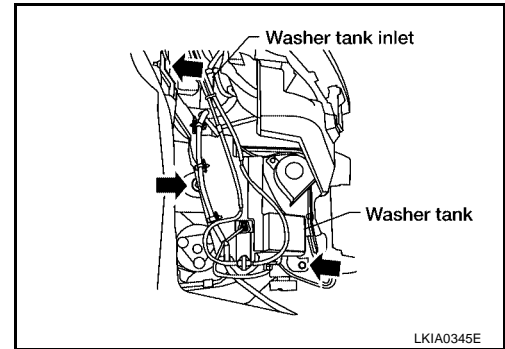

Removal and Installation of Washer Motor

EKS005RE

1. Remove fender protector. Refer to [EI-21, "Removal and Installation"](#) .
2. Remove front and rear washer motor connector and front and rear washer hoses.
3. Pull out front and rear washer motor in the direction of the arrow as shown, and remove the front and rear washer motor from the washer tank.

CAUTION:

When installing front and rear washer motor, there should be no packing twists, etc.

Installation is in the reverse order of removal.

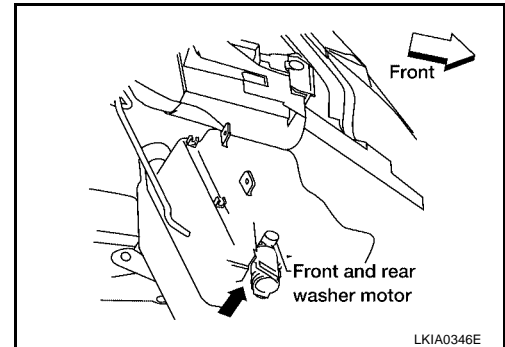

A

B

C

D

E

F

G

H

I

J

WW

L

M

REAR WIPER AND WASHER SYSTEM

REAR WIPER AND WASHER SYSTEM

PDF:28710

Components Parts and Harness Connector Location

EKS0065A

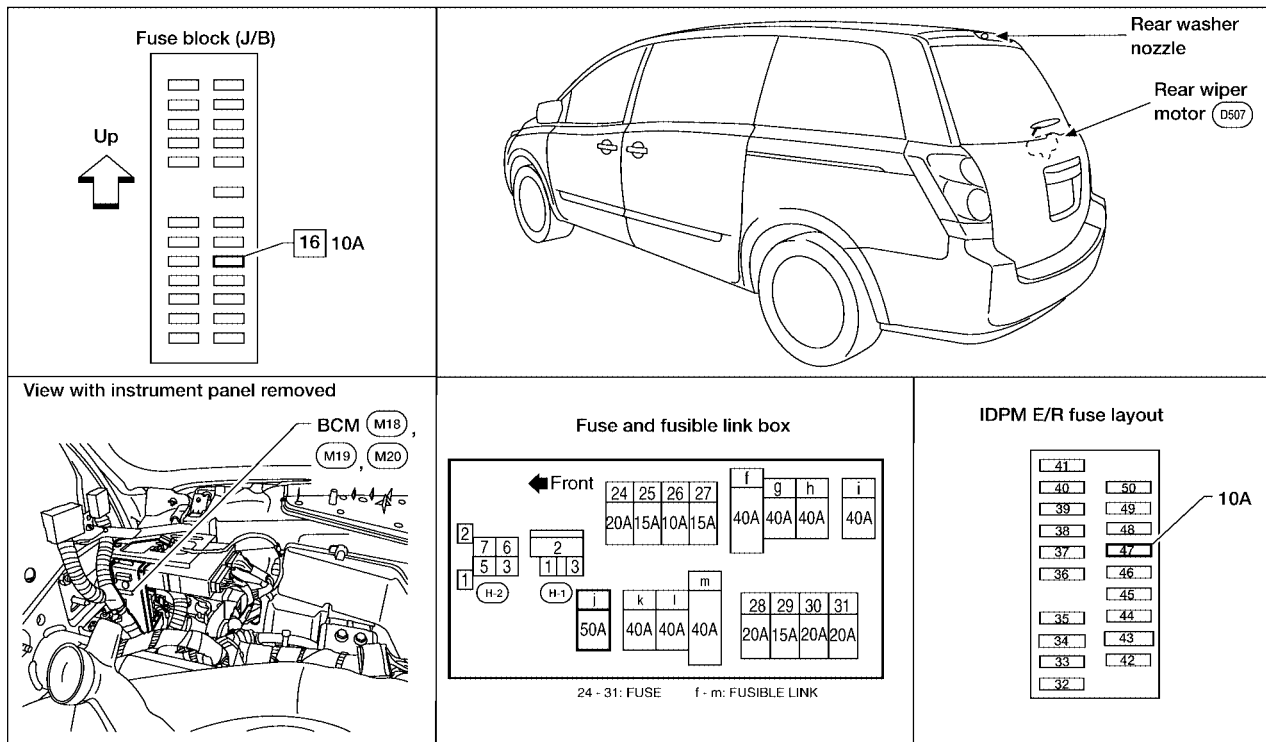

LKIA0341E

System Description

EKS0065B

- Wiper switch (combination switch) is composed of a combination of 5 output terminals and 5 input terminals. Terminal combination status is read by BCM (body control module) when switch is turned ON.
- BCM controls rear wiper ON and INT (intermittent) operation.

Power is supplied at all times

- through 50A fusible link (letter j , located in fusible link box)
- to BCM terminal 55.

With the ignition switch in ON or START position, power is supplied

- through 10A fuse (No. 16, located in fuse block J/B)
- to BCM terminal 38, and
- through 10A fuse (No. 47, located in IPDM E/R)
- through IPDM E/R terminal 44
- to combination switch terminal 14.

Ground is supplied

- to BCM terminals 49 (early production) and 52 and
- to combination switch terminal 12
- through grounds M57, M61 and M79.

REAR WIPER OPERATION

When the ignition switch is in the ON or START position, and the rear wiper switch is in the ON position, the BCM detects a rear wiper ON signal by BCM wiper switch reading function.

When the BCM operates the rear wiper motor, power is supplied

- through BCM terminal 70
- to rear wiper motor terminal B.

REAR WIPER AND WASHER SYSTEM

Ground is supplied

- to rear wiper motor terminal E
- through grounds D403 and D404.

With power and ground supplied, the rear wiper operates.

INTERMITTENT OPERATION

The rear wiper motor operates the wiper arm at low speed approximately every 7 seconds.

When the wiper switch is in the rear wiper INT position, the BCM detects a rear wiper INT signal by BCM wiper switch reading function.

When BCM operates rear wiper motor, power supplied

- through BCM terminal 70
- to rear wiper motor terminal B.

Ground is supplied

- to rear wiper motor terminal E
- through grounds D403 and D404.

With power and ground supplied, the rear wiper operates in intermittent mode.

AUTO STOP OPERATION

When the rear wiper arm is not located at the base of the rear window, and the rear wiper switch is turned OFF, the rear wiper motor will continue to operate until the rear wiper arm is at the base of the rear window.

When the rear wiper arm reaches the base, rear wiper motor terminals P and G are connected.

Ground is supplied

- to BCM terminal 59
- through rear wiper motor terminal P
- through rear wiper motor terminal G
- through grounds D403 and D404.

REAR WASHER OPERATION

When the ignition switch is in the ON or START position, and the front and rear washer switches are OFF, the front and rear washer motor is supplied power

- through 10A fuse (No. 47, located in the IPDM E/R)
- through IPDM E/R terminal 44
- through combination switch (wiper switch) terminal 14
- through combination switch (wiper switch) terminal 11
- to front and rear washer motor terminal -, and
- through combination switch (wiper switch) terminal 13
- to front and rear washer motor terminal +.

When the rear wiper switch is in rear washer position, the BCM detects a rear washer signal by BCM wiper switch reading function. Combination switch ground is supplied

- to front and rear washer motor terminal +
- through combination switch (wiper switch) terminal 13
- through combination switch (wiper switch) terminal 12
- through grounds M57, M61 and M79.

With ground supplied, the front and rear washer motor is operated in the rear direction.

When the BCM detects that the rear washer motor has operated for 0.4 seconds or longer, BCM operates the rear wiper motor.

When the BCM detects that the rear washer switch is in OFF, the rear wiper motor cycles approximately 3 times and then stops.

BCM WIPER SWITCH READING FUNCTION

Refer to [BCS-3, "COMBINATION SWITCH READING FUNCTION"](#) .

REAR WIPER AND WASHER SYSTEM

EKS0065C

Wiring Diagram — WIP/ R —

WW-WIP/R-01

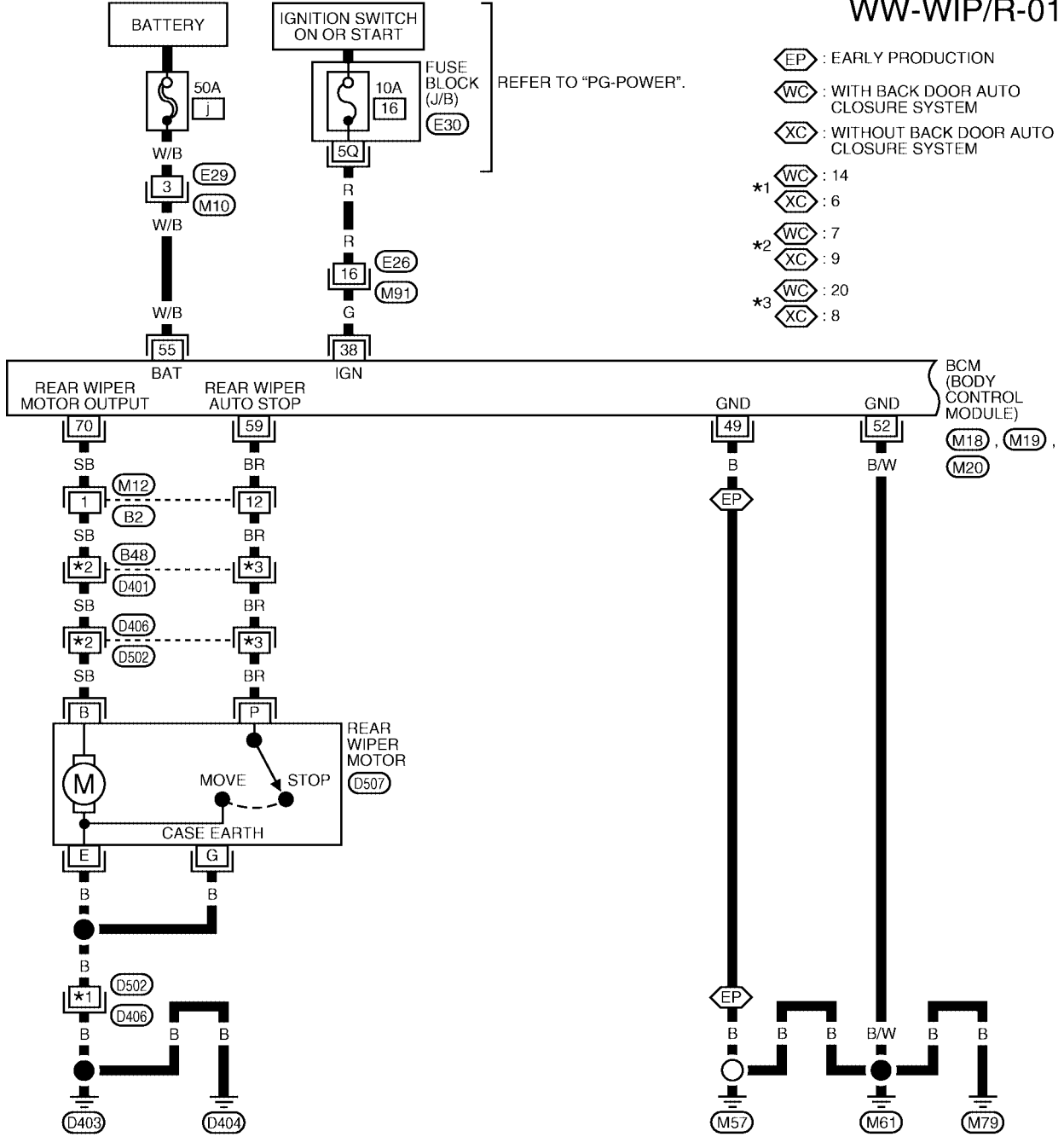

- EP : EARLY PRODUCTION
- WC : WITH BACK DOOR AUTO CLOSURE SYSTEM
- XC : WITHOUT BACK DOOR AUTO CLOSURE SYSTEM
- *1 WC : 14
XC : 6
- *2 WC : 7
XC : 9
- *3 WC : 20
XC : 8

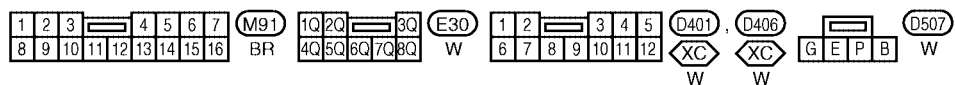
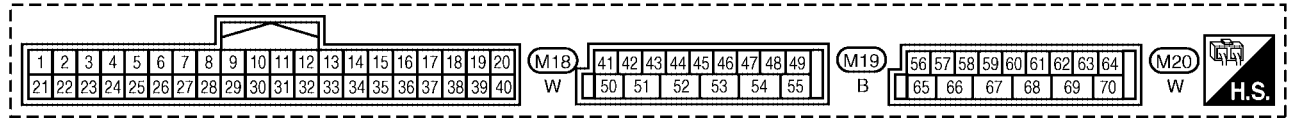
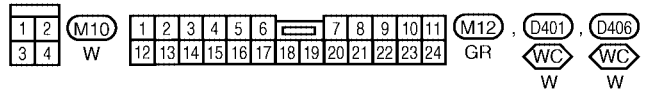

WKWA1527E

REAR WIPER AND WASHER SYSTEM

WW-WIP/R-02

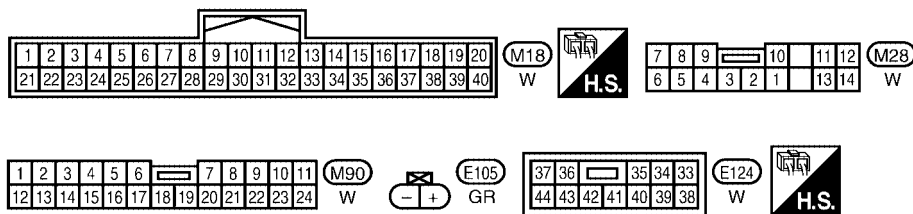
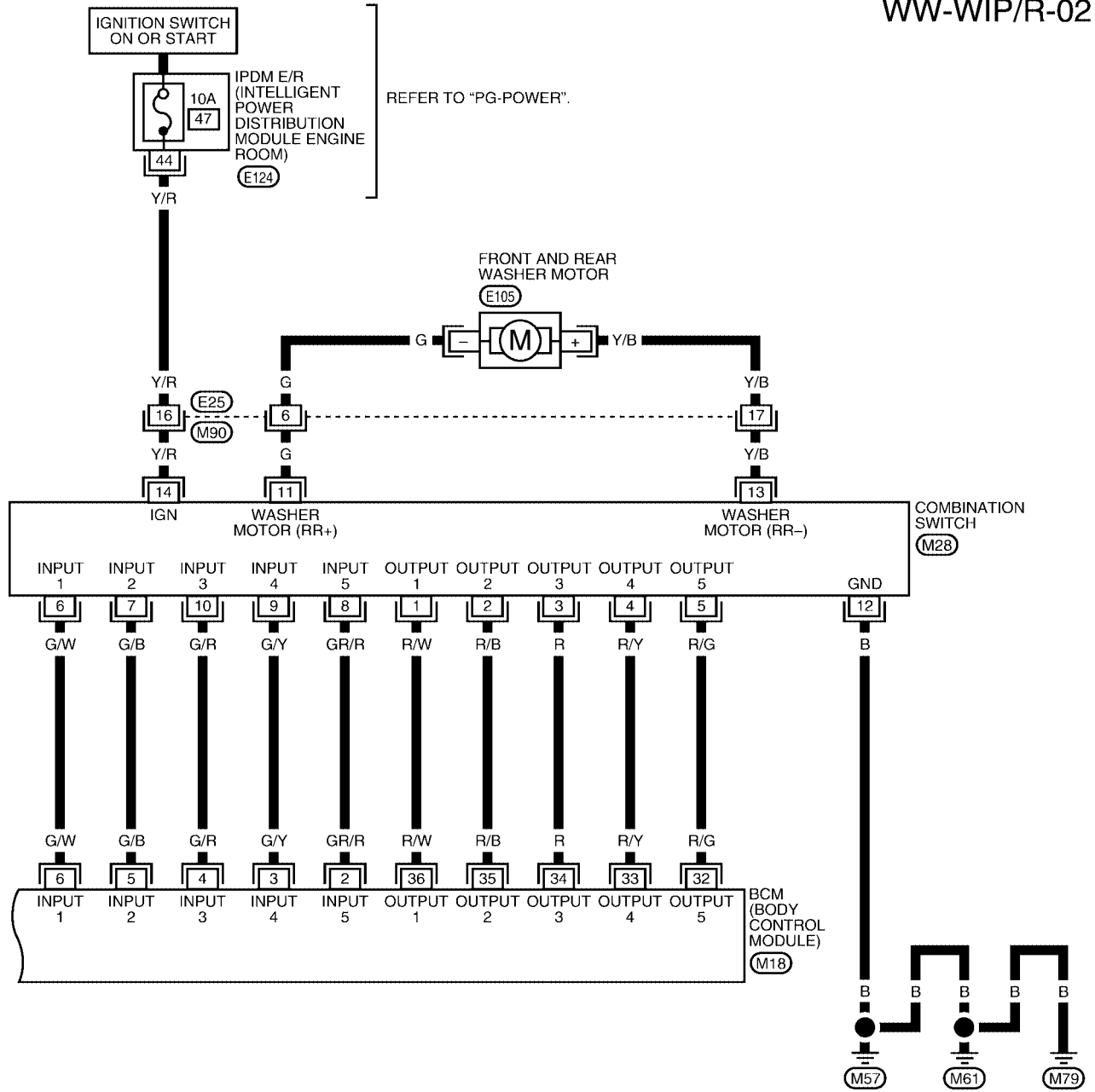



LKWA0253E

REAR WIPER AND WASHER SYSTEM

Terminals and Reference Values for BCM

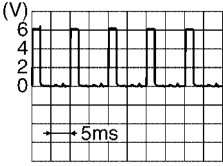
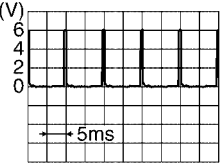
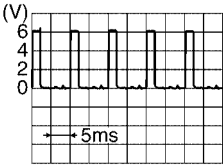
EKS0065D

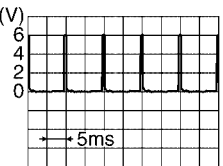
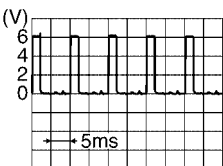
Terminal No. (Wire color)	Signal name	Measuring condition		Reference Value (V) (Approx.)
		Ignition switch	Operation or condition	
2 (GR/R)	Combination switch input 5	ON	<ul style="list-style-type: none"> Light switch and wiper switch OFF Wiper dial position 4 	 <p style="text-align: right;">SKIA5291E</p>
3 (G/Y)	Combination switch input 4	ON	<ul style="list-style-type: none"> Light switch and wiper switch OFF Wiper dial position 4 	 <p style="text-align: right;">SKIA5292E</p>
4 (G/R)	Combination switch input 3	ON	<ul style="list-style-type: none"> Light switch and wiper switch OFF Wiper dial position 4 	 <p style="text-align: right;">SKIA5291E</p>
5 (G/B)	Combination switch input 2	ON	<ul style="list-style-type: none"> Light switch and wiper switch OFF Wiper dial position 4 	 <p style="text-align: right;">SKIA5292E</p>
6 (G/W)	Combination switch input 1	ON		
32 (R/G)	Combination switch output 5	ON	<ul style="list-style-type: none"> Light switch and wiper switch OFF Wiper dial position 4 	 <p style="text-align: right;">SKIA5291E</p>
33 (R/Y)	Combination switch output 4	ON	<ul style="list-style-type: none"> Light switch and wiper switch OFF Wiper dial position 4 	 <p style="text-align: right;">SKIA5292E</p>
34 (R)	Combination switch output 3	ON	<ul style="list-style-type: none"> Light switch and wiper switch OFF Wiper dial position 4 	 <p style="text-align: right;">SKIA5291E</p>

REAR WIPER AND WASHER SYSTEM

Terminal No. (Wire color)	Signal name	Measuring condition		Reference Value (V) (Approx.)
		Ignition switch	Operation or condition	
35 (R/B)	Combination switch output 2	ON		
36 (R/W)	Combination switch output 1	ON	<ul style="list-style-type: none"> ● Light switch and wiper switch OFF ● Wiper dial position 4 	
38 (G)	Ignition switch (ON)	ON	—	Battery voltage
49 (B)*	Ground	ON	—	0V
52 (B/W)	Ground	ON	—	0V
55 (W/B)	Battery power	OFF	—	Battery voltage
59 (BR)	Rear wiper auto stop signal	ON	Rear wiper operating	0V
			Rear wiper stopped	Battery voltage
70 (SB)	Rear wiper motor output signal	ON	Rear wiper switch OFF	0V
			Rear wiper switch ON	Battery voltage

* Early production

Terminals and Reference Values for IPDM E/R

EKS0065E

Terminal No.	Wire color	Signal name	Measuring condition		Reference Value (V) (Approx.)
			Ignition switch	Operation or condition	
44	Y/R	Front and rear washer motor power supply	ON	—	Battery voltage

How to Proceed With Trouble Diagnosis

EKS0065F

1. Confirm the symptoms and customer complaint.
2. Understand operation description and function description. Refer to [WW-30, "System Description"](#).
3. Perform the Preliminary Check. Refer to [WW-35, "Preliminary Check"](#).
4. Check symptom and repair or replace the cause of malfunction.
5. Does the rear wiper operate normally? If YES: GO TO 6. If NO: GO TO 4.
6. Inspection End.

Preliminary Check INSPECTION FOR POWER SUPPLY AND GROUND CIRCUIT

EKS0065G

Inspection procedure

1. CHECK FUSE

Check if wiper or washer fuse is blown.

Unit	Power source	Fuse No.
Front and rear washer motor	Ignition ON or START	47
BCM	Ignition ON or START	16
	Battery	j

OK or NG

OK >> GO TO 2.

NG >> If fuse is blown, be sure to eliminate cause of blown fuse before installing new fuse. Refer to [PG-4, "POWER SUPPLY ROUTING CIRCUIT"](#).

REAR WIPER AND WASHER SYSTEM

2. CHECK POWER SUPPLY CIRCUIT

1. Disconnect BCM connectors.
2. Check voltage between BCM harness connector terminals and ground.

Terminals		Ignition switch position		
(+)		(-)	OFF	ON
Connector	Terminal (Wire color)			
M18	38 (G)	Ground	0V	Battery voltage
M19	55 (W/B)		Battery voltage	Battery voltage

OK or NG

OK >> GO TO 3.

NG >> Check harness for open or short between BCM and fuse.

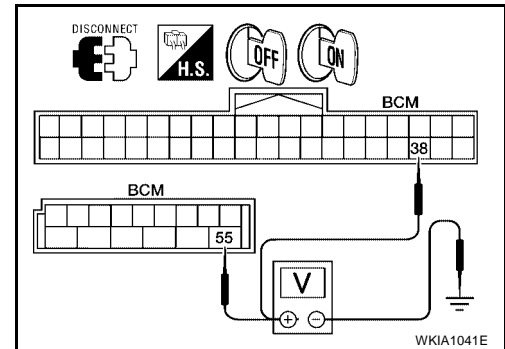

3. GROUND CIRCUIT INSPECTION (BCM)

Check for continuity between the following terminals on BCM connector and ground.

Terminals		Ignition switch condition	Continuity
Connector	Terminal (wire color)		
M19	49 (B)*	Ground	Yes
M19	52 (B/W)		

* Early production

OK or NG

OK >> Inspection End.

NG >> Repair/replace BCM ground circuit.

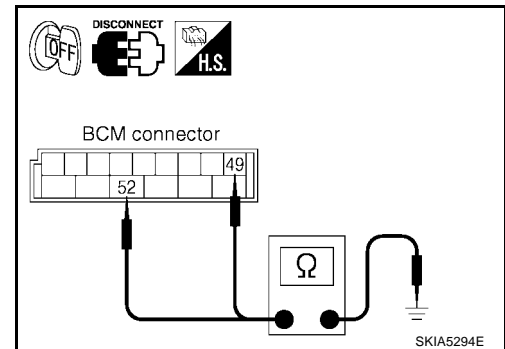

REAR WIPER AND WASHER SYSTEM

CONSULT-II Function (BCM)

EKS0065H

CONSULT-II can display each diagnostic item using the diagnostic test modes shown following.

BCM diagnostic test item	Diagnostic mode	Description
Inspection by part	WORK SUPPORT	Supports inspections and adjustments. Commands are transmitted to the BCM for setting the status suitable for required operation, input/output signals are received from the BCM and received data is displayed.
	DATA MONITOR	Displays BCM input/output data in real time.
	ACTIVE TEST	Operation of electrical loads can be checked by sending drive signal to them.
	SELF-DIAG RESULTS	Displays BCM self-diagnosis results.
	CAN DIAG SUPPORT MNTR	The result of transmit/receive diagnosis of CAN communication can be read.
	ECU PART NUMBER	BCM part number can be read.
	CONFIGURATION	Performs BCM configuration read/write functions.

CONSULT-II OPERATION

CAUTION:

If CONSULT-II is used with no connection of CONSULT-II CONVERTER, malfunctions might be detected in self-diagnosis depending on control unit which carries out CAN communication.

1. With the ignition switch OFF, connect CONSULT-II and CONSULT-II CONVERTER to the data link connector, then turn the ignition switch ON.

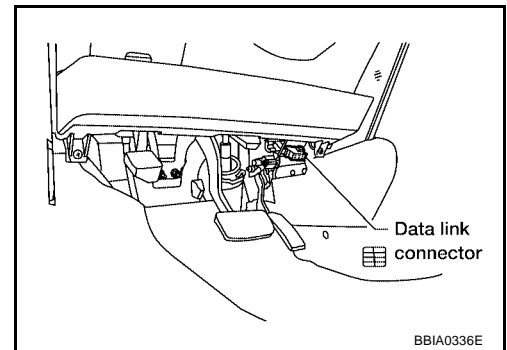

2. Touch "START (NISSAN BASED VHCL)".

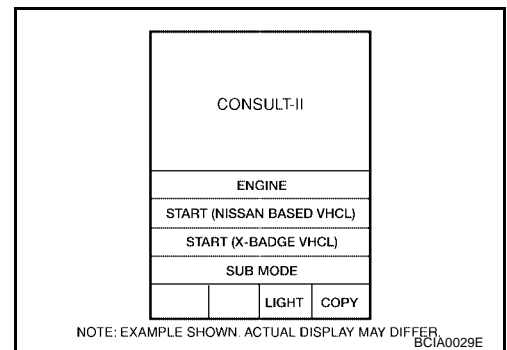

3. Touch "BCM" on the "SELECT SYSTEM" screen. If "BCM" is not indicated, go to [GI-37, "CONSULT-II Data Link Connector \(DLC\) Circuit"](#).

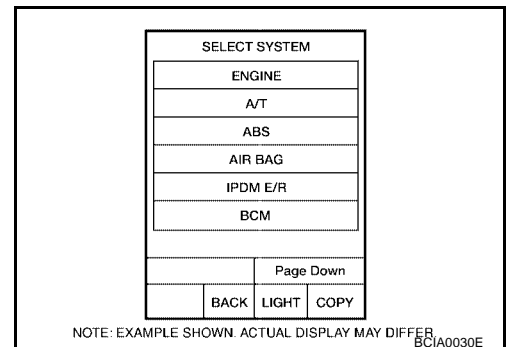

REAR WIPER AND WASHER SYSTEM

- Select the desired part to be diagnosed on the "SELECT TEST ITEM" screen.

SELECT TEST ITEM			
HEAD LAMP			
WIPER			
FLASHER			
AIR CONDITIONER			
COMB SW			
BCM			
Scroll Up		Page Down	
BACK	LIGHT	COPY	

LKIA0183E

DATA MONITOR

Operation Procedure

- Touch "WIPER" on "SELECT TEST ITEM" screen.
- Touch "DATA MONITOR" on "SELECT DIAG MODE" screen.
- Touch either "ALL SIGNALS" or "SELECTION FROM MENU" on "SELECT MONITOR ITEM" screen.

All signals	Monitors all the items.
Selection from menu	Selects and monitors the individual item selected.

- Touch "START".
- When "SELECTION FROM MENU" is selected, touch items to be monitored. When "ALL SIGNALS" is selected, all the items will be monitored.
- Touch "RECORD" while monitoring, then the status of the monitored item can be recorded. To stop recording, touch "STOP".

Display Item List

Monitor item name "OPERATION OR UNIT"	Contents
IGN ON SW "ON/OFF"	Displays "IGN Position (ON)/OFF, ACC Position (OFF)" status as judged from ignition switch signal.
IGN SW CAN "ON/OFF"	Displays "IGN Position (ON)/OFF, ACC Position (OFF)" status as judged from ignition switch signal.
FR WIPER INT "ON/OFF"	Displays "Front Wiper INT (ON)/Other (OFF)" status as judged from wiper switch signal.
FR WIPER LOW "ON/OFF"	Displays "Front Wiper LOW (ON)/Other (OFF)" status as judged from wiper switch signal.
FR WIPER HI "ON/OFF"	Displays "Front Wiper HI (ON)/Other (OFF)" status as judged from wiper switch signal.
FR WASHER SW "ON/OFF"	Displays "Front Washer Switch (ON)/Other (OFF)" status as judged from wiper switch signal.
INT VOLUME (1 - 7)	Displays intermittent operation dial position setting (1 - 7) as judged from wiper switch signal.
VEHICLE SPEED "0.0 km/h"	Displays vehicle speed as received over CAN communication.
FR WIPER STOP "ON/OFF"	Displays "Stopped (ON)/Operating (OFF)" status as judged from the auto-stop signal.
RR WIPER INT "ON/OFF"	Displays "Rear Wiper INT (ON)/Other (OFF)" status as judged from wiper switch signal.
RR WIPER ON "ON/OFF"	Displays "Rear Wiper (ON)/Other (OFF)" status as judged from wiper switch signal.
RR WASHER SW "ON/OFF"	Displays "Rear Washer Switch (ON)/Other (OFF)" status as judged from wiper switch signal.
RR WIPER STOP "ON/OFF"	Displays "Stopped (OFF)/Operating (ON)" status as judged from the auto-stop signal.

ACTIVE TEST

Operation Procedure

- Touch "WIPER" on the "SELECT TEST ITEM" screen.
- Touch "ACTIVE TEST" on the "SELECT DIAG MODE" screen.
- Touch item to be tested and check operation of the selected item.
- During the operation check, touching "BACK" deactivates the operation.

REAR WIPER AND WASHER SYSTEM

Display Item List

Test item	Display on CONSULT-II screen	Description
Front wiper HI output	FR WIPER (HI)	Front wiper HI can be operated by any ON-OFF operation.
Front wiper LO output	FR WIPER (LO)	Front wiper LO can be operated by any ON-OFF operation.
Front wiper INT output	FR WIPER (INT)	Front wiper INT can be operated by any ON-OFF operation.
Rear wiper output	RR WIPER	Rear wiper can be operated by any ON-OFF operation.

Rear Wiper Does Not Operate

EKS0065I

1. REAR WIPER ACTIVE TEST

1. Turn on rear wiper using "ACTIVE TEST". Refer to [WW-38, "ACTIVE TEST"](#).
2. Make sure rear wiper operates.

Wiper should operate.

OK or NG

- OK >> GO TO 6.
NG >> GO TO 2.

2. CHECK REAR WIPER MOTOR CIRCUIT

1. Turn ignition switch OFF.
2. Disconnect BCM connector and rear wiper motor connector.
3. Check continuity between BCM harness connector M20 terminal 70 (SB) and rear wiper motor harness connector D507 terminal B (SB).

Continuity should exist.

OK or NO

- OK >> GO TO 3.
NO >> Repair harness or connector.

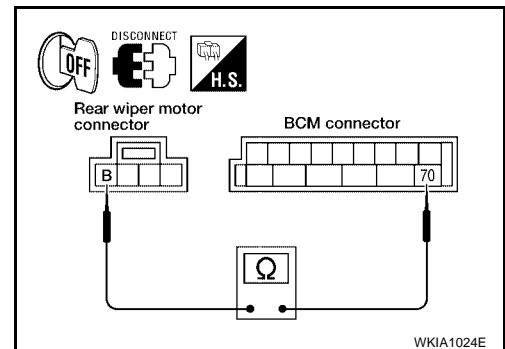

3. CHECK REAR WIPER MOTOR SHORT CIRCUIT

Check continuity between rear wiper motor harness connector D507 terminal B (SB) and ground.

Continuity should not exist.

OK or NG

- OK >> GO TO 4.
NG >> After repairing harness, be sure to disconnect battery negative cable, and then reconnect it.

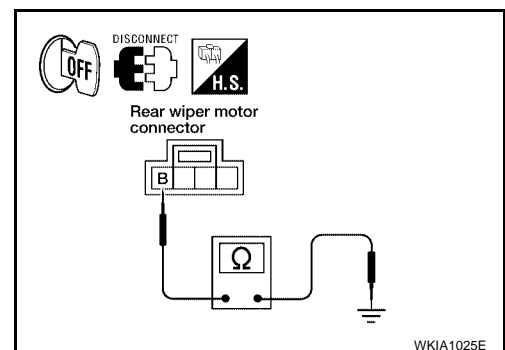

REAR WIPER AND WASHER SYSTEM

4. CHECK GROUND CIRCUIT

Check continuity between rear wiper motor harness connector D507 terminal E (B) and ground.

Continuity should exist.

OK or NG

- OK >> GO TO 5.
- NG >> Repair harness or connector.

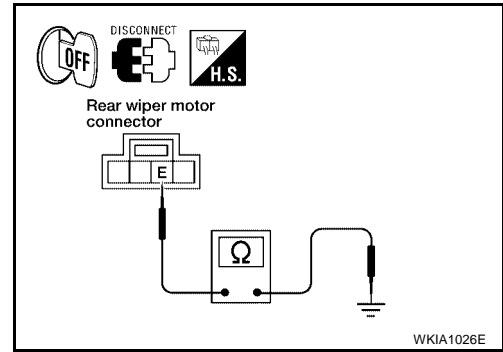

5. CHECK REAR WIPER OPERATING

1. Connect BCM connector and rear wiper motor connector.
2. Select "RR WIPER" during "ACTIVE TEST". Refer to [WW-38, "ACTIVE TEST"](#). When rear wiper is operating, check voltage between BCM harness connector terminal and ground.

Terminals			Condition	Voltage (Approx.)
(+)	(-)			
Connector	Terminal (Wire color)			
M20	70 (SB)	Ground	Stopped	0V
			ON operation	Battery voltage

OK or NG

- OK >> Replace rear wiper motor. Refer to [WW-43, "Removal and Installation of Rear Wiper Motor"](#).
- NG >> Replace BCM. Refer to [BCS-19, "Removal and Installation of BCM"](#).

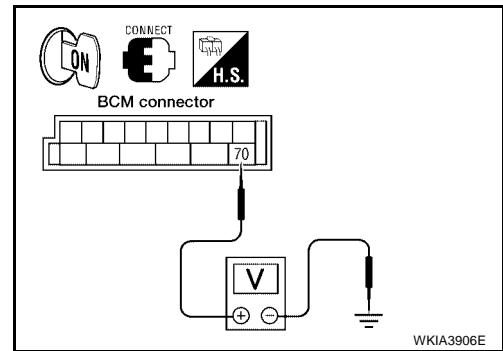

6. CHECK COMBINATION SWITCH INPUT SIGNAL

Select "BCM" on CONSULT-II. With "WIPER" data monitor, make sure "RR WIPER INT", "RR WIPER ON" turn ON-OFF according to operation of wiper switch.

When wiper switch is in INT position : RR WIPER INT ON

When wiper switch is in ON position : RR WIPER ON

OK or NG

- OK >> Replace BCM. Refer to [BCS-19, "Removal and Installation of BCM"](#).
- NG >> Check the wiper switch. Refer to [BCS-3, "COMBINATION SWITCH READING FUNCTION"](#).

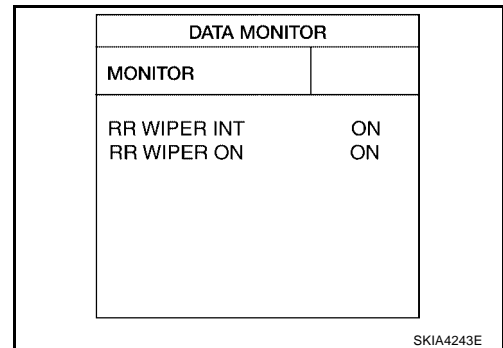

REAR WIPER AND WASHER SYSTEM

EKS0065J

Rear Wiper Stop Position Is Incorrect

1. CHECK COMBINATION SWITCH INPUT SIGNAL

Select "BCM" on CONSULT-II. With "WIPER" data monitor, make sure "RR WIPER STOP" turns ON-OFF according to wiper operation.

When wiper switch is in OFF position : RR WIPER STOP OFF

OK or NG

- OK >> Replace BCM. Refer to [BCS-19, "Removal and Installation of BCM"](#).
- NG >> GO TO 2.

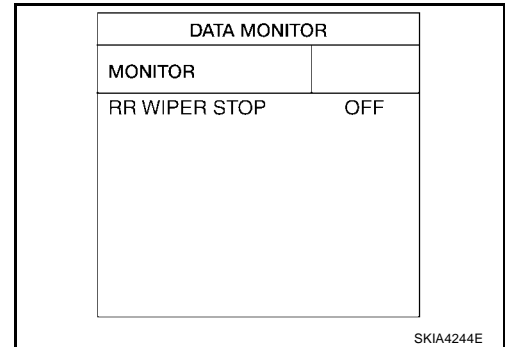

2. CHECK REAR WIPER MOTOR CIRCUIT

1. Turn ignition switch OFF.
2. Disconnect BCM connector and rear wiper motor connector.
3. Check continuity between BCM harness connector M20 terminal 59 (BR) and rear wiper motor harness connector D507 terminal P (BR).

Continuity should exist.

OK or NG

- OK >> GO TO 3.
- NG >> Repair harness or connector.

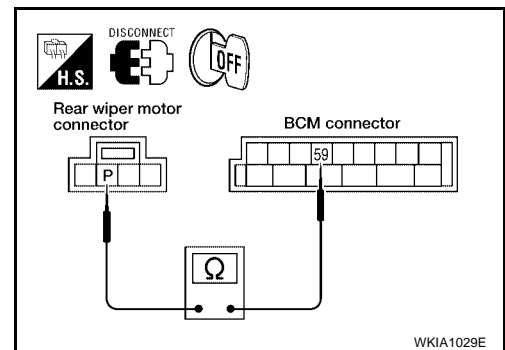

3. CHECK REAR WIPER MOTOR SHORT CIRCUIT

Check continuity between rear wiper motor harness connector D507 terminal P (BR) and ground.

Continuity should not exist.

OK or NG

- OK >> GO TO 4.
- NG >> Repair harness or connector.

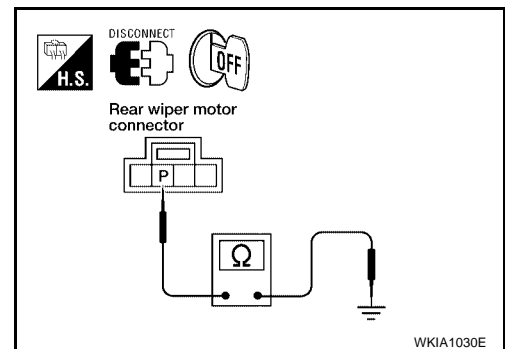

4. CHECK GROUND CIRCUIT

Check continuity between rear wiper motor harness connector D507 terminal E (B) and ground.

Continuity should exist.

OK or NG

- OK >> GO TO 5.
- NG >> Repair harness or connector.

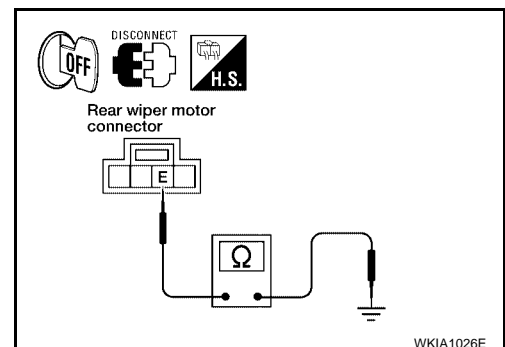

A
B
C
D
E
F
G
H
I
J
L
M

WW

REAR WIPER AND WASHER SYSTEM

5. CHECK AUTO STOP SIGNAL

1. Connect BCM connector.
2. Turn ignition switch ON.
3. Check voltage between rear wiper motor harness connector D507 terminal P (BR) and ground.

Battery voltage should exist.

OK or NG

- OK >> Replace BCM. Refer to [BCS-19, "Removal and Installation of BCM"](#).
- NG >> Replace rear wiper motor. Refer to [WW-43, "Removal and Installation of Rear Wiper Motor"](#).

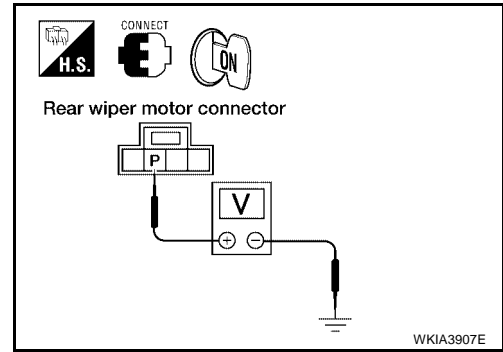

WKIA3907E

Only Rear Wiper Does Not Operate

EKS0065K

1. CHECK COMBINATION SWITCH INPUT SIGNAL

Select "BCM" on CONSULT-II. With "WIPER" data monitor, make sure "RR WIPER ON" turns ON-OFF according to operation of wiper switch.

When rear wiper switch is in ON position : RR WIPER ON

OK or NG

- OK >> Replace BCM. Refer to [BCS-19, "Removal and Installation of BCM"](#).
- NG >> Check the wiper switch. Refer to [BCS-3, "COMBINATION SWITCH READING FUNCTION"](#).

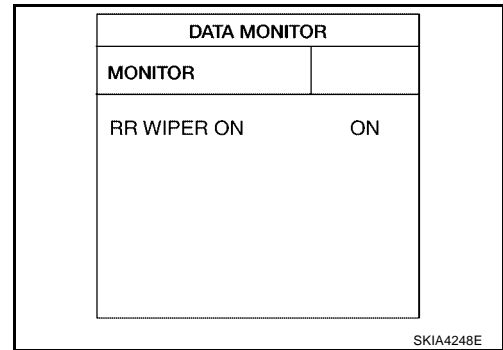

SKIA4248E

Only Rear Wiper Intermittent Does Not Operate

EKS0065L

1. CHECK COMBINATION SWITCH INPUT SIGNAL

Select "BCM" on CONSULT-II. With "WIPER" data monitor, make sure "RR WIPER INT" turns ON-OFF according to operation of wiper switch.

When rear wiper switch is in INT position : RR WIPER INT ON

OK or NG

- OK >> Replace BCM. Refer to [BCS-19, "Removal and Installation of BCM"](#).
- NG >> Check the wiper switch. Refer to [BCS-3, "COMBINATION SWITCH READING FUNCTION"](#).

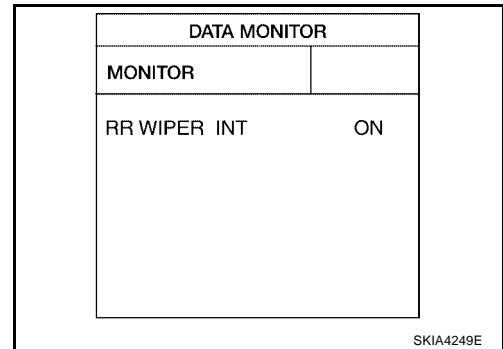

SKIA4249E

Wiper Does Not Wipe When Rear Washer Operates

EKS0065M

1. CHECK COMBINATION SWITCH INPUT SIGNAL

Select "BCM" on CONSULT-II. With "WIPER" data monitor, make sure "RR WASHER SW" turns ON-OFF according to operation of rear washer switch.

When rear wiper switch is in WASHER position : RR WASHER SW ON

OK or NG

- OK >> Replace BCM. Refer to [BCS-19, "Removal and Installation of BCM"](#).
- NG >> Check the wiper switch. Refer to [BCS-3, "COMBINATION SWITCH READING FUNCTION"](#).

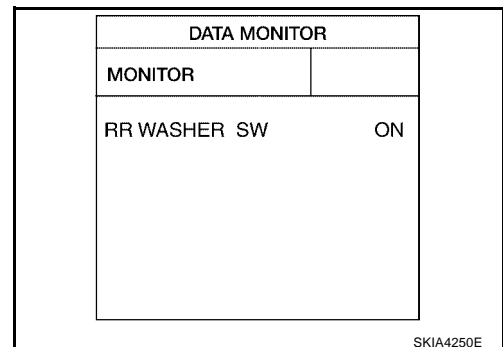

SKIA4250E

REAR WIPER AND WASHER SYSTEM

EKS0065N

Removal and Installation of Rear Wiper Arm

REMOVAL

1. Operate rear wiper motor one full cycle, then turn "OFF" (Auto Stop).
2. Lift wiper arm pivot cover open and remove mounting nut, then remove the wiper arm.

INSTALLATION

1. Prior to rear wiper arm installation: operate wiper motor one full cycle then turn "OFF" (Auto Stop).
 - Operate wiper motor one full cycle, then turn "OFF" (Auto Stop).
 - Using a suitable brush, clean pivot area as illustrated. This will reduce the possibility of wiper arm looseness.
2. Install rear wiper arm onto pivot and ensure wiper blade is parallel to the ground.
3. Tighten wiper arm mounting nut to specification, then close pivot cover.

Rear wiper arm
mounting nut

: 15.5 N·m (1.6 kg·m, 11 ft·lb)

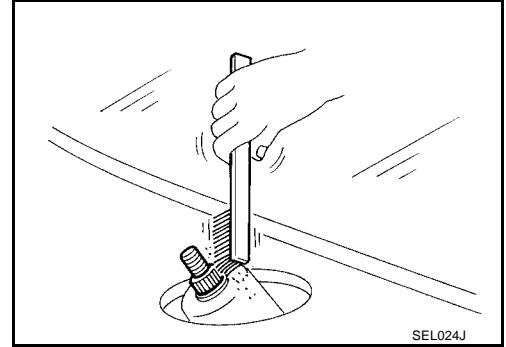

Removal and Installation of Rear Wiper Motor

EKS0065O

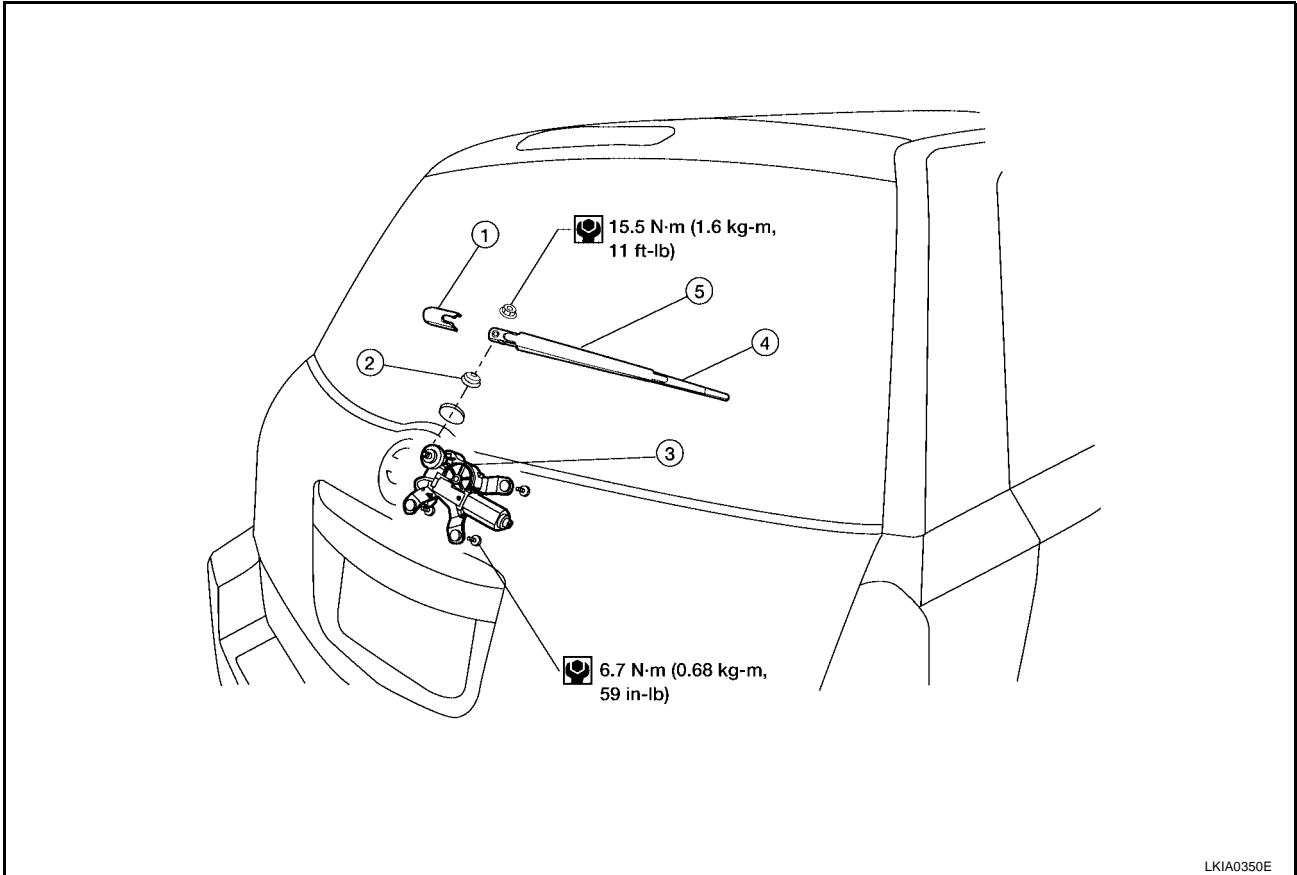

- | | | |
|--------------------|--------------|---------------------|
| 1. Wiper arm cover | 2. Pivot cap | 3. Rear wiper motor |
| 4. Wiper blade | 5. Wiper arm | |

A
B
C
D
E
F
G
H
I
J
L
M

WW

REAR WIPER AND WASHER SYSTEM

REMOVAL

1. Remove rear wiper arm. Refer to [WW-43, "Removal and Installation of Rear Wiper Arm"](#).
2. Remove pivot cap.
3. Remove back door finisher lower. Refer to [EI-34, "Removal and Installation"](#).
4. Disconnect rear wiper motor connector.
5. Remove rear wiper motor mounting bolts, and remove rear wiper motor.

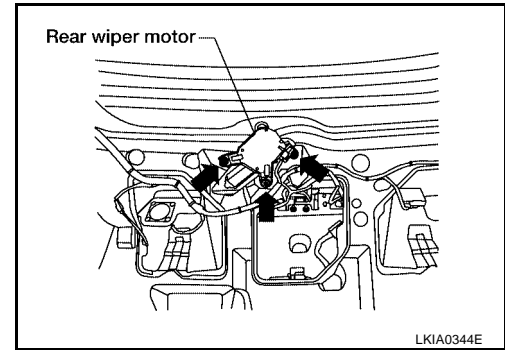

INSTALLATION

CAUTION:

- Do not drop the wiper motor or cause it to contact other parts.
1. Clean up the pivot area as illustrated. This will reduce possibility of wiper arm looseness.
 2. Install rear wiper motor to the vehicle.
 3. Attach pivot cap.
 4. Connect rear wiper motor connector.
 5. Install back door finisher lower. Refer to [EI-34, "Removal and Installation"](#).
 6. Attach wiper arm. Refer to [WW-43, "Removal and Installation of Rear Wiper Arm"](#).

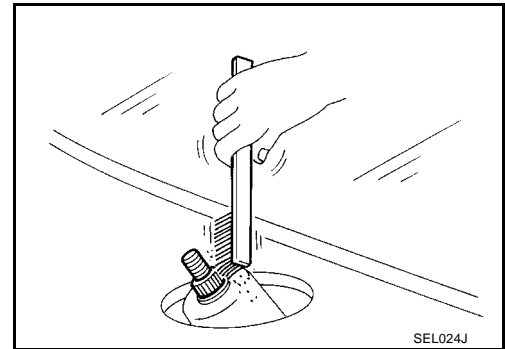

Rear Washer Nozzle Adjustment

- Adjust washer nozzle with suitable tool as shown in the figure.

Adjustable range : $\pm 15^\circ$ (In any direction)

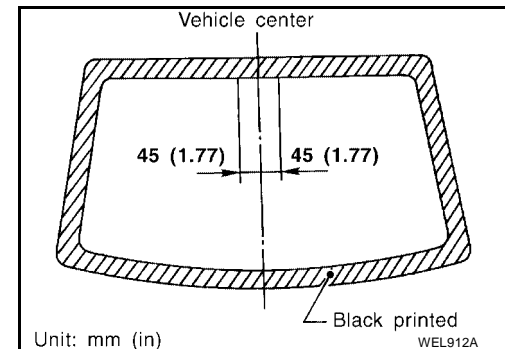
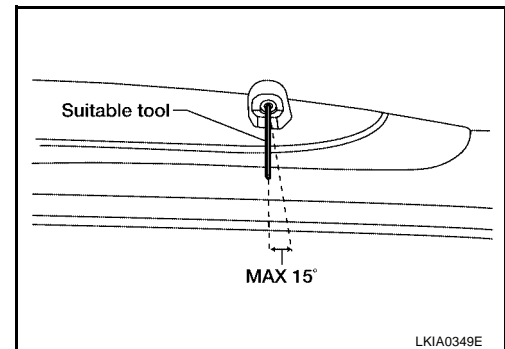

REAR WIPER AND WASHER SYSTEM

Rear Washer Tube Layout

EKS0065Q

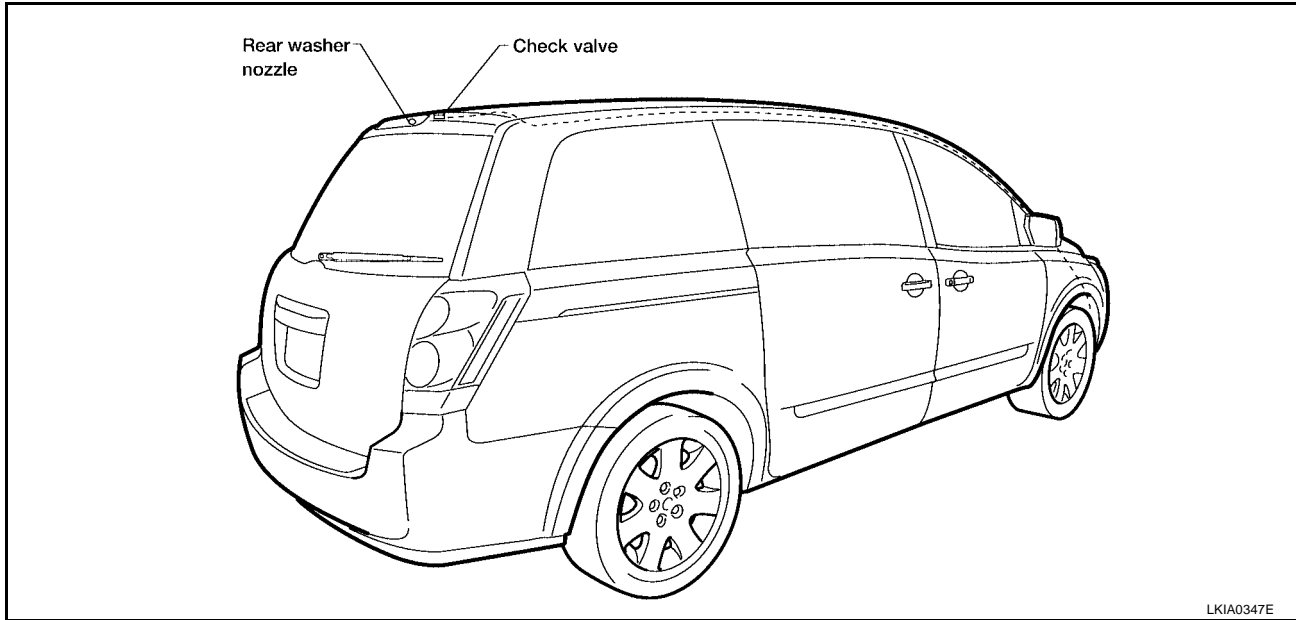

LKIA0347E

Removal and Installation for Rear Washer Nozzle

EKS0065R

REMOVAL

1. Remove back door finisher upper. Refer to [EI-34, "Removal and Installation"](#).
2. Remove rear washer tube from nozzle.
3. Release retaining clips, and remove washer nozzle.

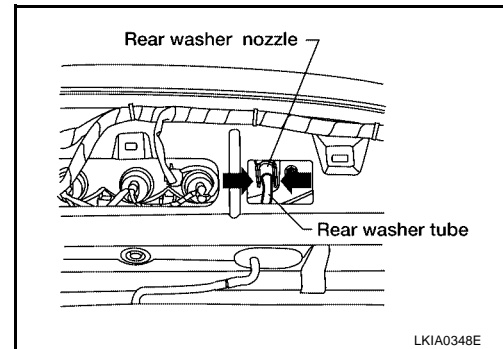

LKIA0348E

INSTALLATION

Installation is in the reverse order of removal.

Check Valve

EKS0065S

- A check valve is provided in the washer fluid line. Be careful not to connect check valve to washer tube in the wrong direction.

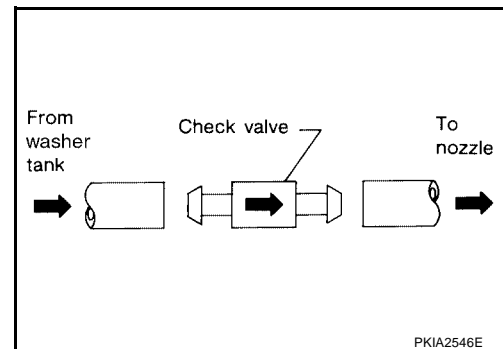

PKIA2546E

Removal and Installation for Rear Wiper and Washer Switch

EKS0065T

Refer to [WW-28, "Removal and Installation of Wiper and Washer Switch"](#).

Removal and Installation for Washer Tank

EKS0065U

Refer to [WW-29, "Removal and Installation of Washer Tank"](#).

REAR WIPER AND WASHER SYSTEM

Removal and Installation for Washer Motor

EKS0065V

Refer to [WW-29, "Removal and Installation of Washer Motor"](#).

SOCKET

PF2:253A2

EKS005RH

SOCKET

Wiring Diagram — P/SCKT —

WW-P/SCKT-01

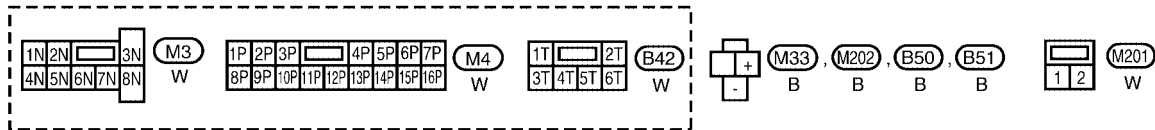
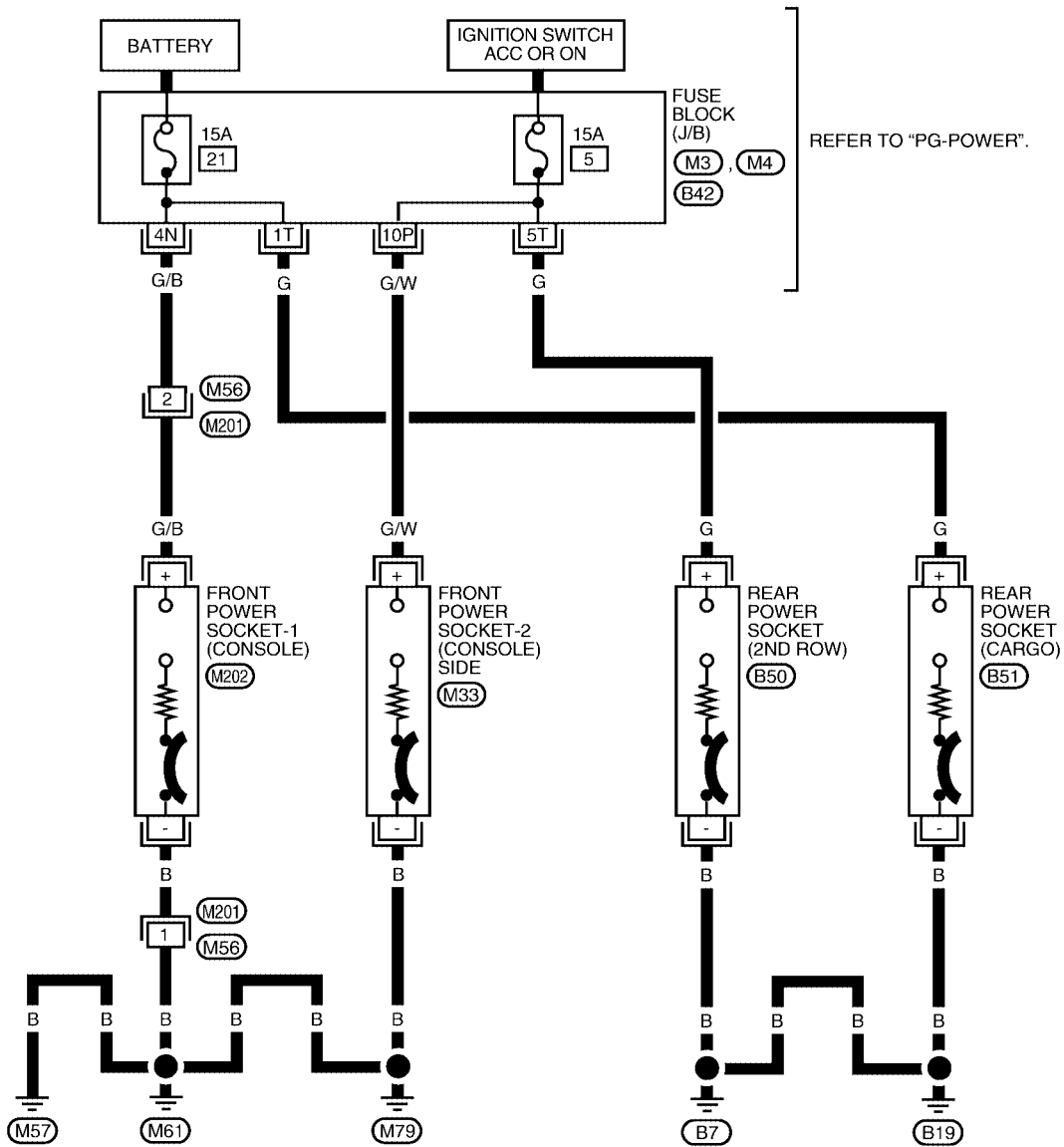

WKWA2792E

SOCKET

EKS005RI

Removal and Installation of Power Sockets

REMOVAL

NOTE:

Removal and Installation is common for all power sockets.

1. Remove inner socket from the ring, while pressing the hook on the ring out from square hole.
2. Disconnect power socket connector.
3. Remove ring from power socket finisher while pressing pawls.

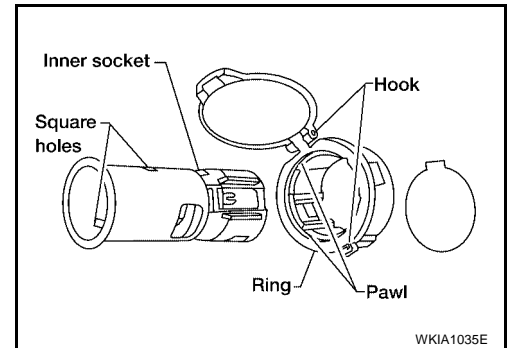

INSTALLATION

Installation is in reverse order of removal.

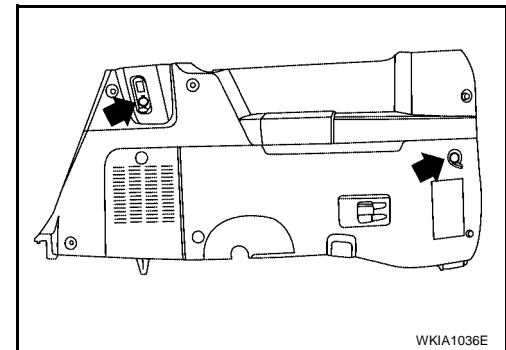
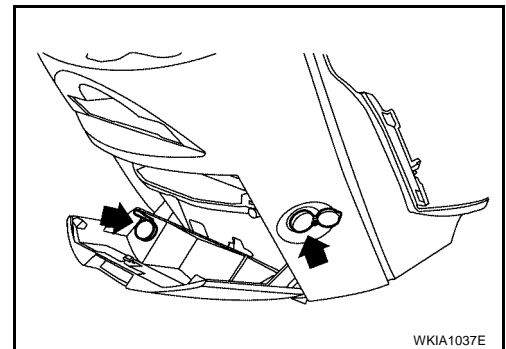

HORN

PF25610

HORN

Wiring Diagram — HORN —

EKS005RJ

WW-HORN-01

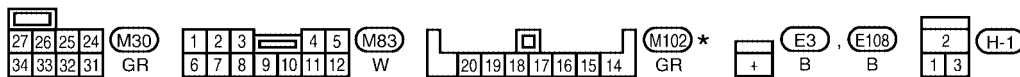
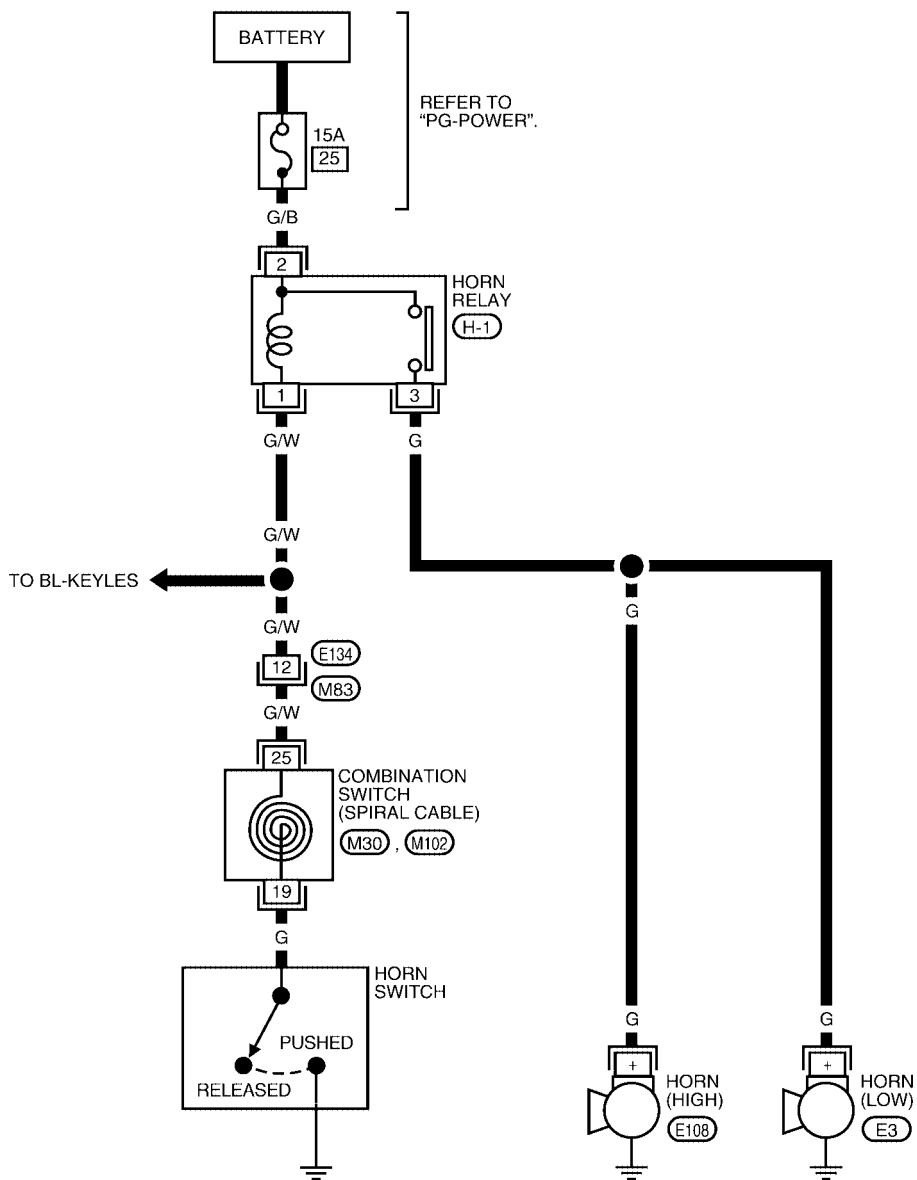

*: THIS CONNECTOR IS NOT SHOWN IN "HARNES LAYOUT" OF PG SECTION.

LKWA0254E

HORN

EKS0065W

Removal and Installation

REMOVAL

1. Remove the front bumper. Refer to [EI-13, "Removal and Installation"](#).
2. Disconnect horn connector.
3. Remove horn bolt and remove horn from vehicle.

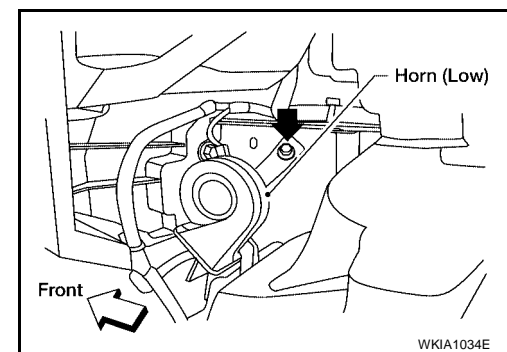
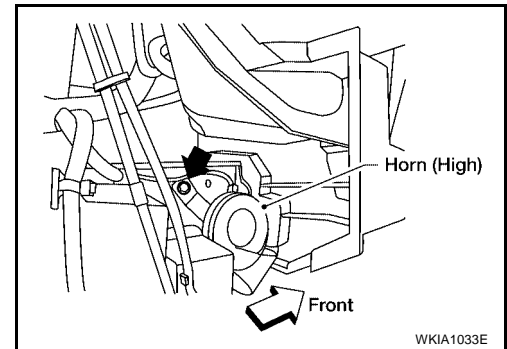

INSTALLATION

1. Tighten horn bolt to specified torque.

Horn bolt : 17 N·m (1.7 kg-m, 13 ft-lb)

2. Reconnect horn connector.
3. Install front bumper. Refer to [EI-13, "Removal and Installation"](#).