

SECTION **ATC**

AUTOMATIC AIR CONDITIONER

A
B
C

CONTENTS

<p>PRECAUTIONS 5</p> <p> Precautions for Supplemental Restraint System (SRS) "AIR BAG" and "SEAT BELT PRE-TENSIONER" 5</p> <p> Precautions for Working with HFC-134a (R-134a).... 5</p> <p> Contaminated Refrigerant 5</p> <p> General Refrigerant Precautions 6</p> <p> Precautions for Leak Detection Dye 6</p> <p> A/C Identification Label 6</p> <p> Precautions for Refrigerant Connection 6</p> <p> FEATURES OF NEW TYPE REFRIGERANT CONNECTION 7</p> <p> O-RING AND REFRIGERANT CONNECTION..... 8</p> <p> Precautions for Servicing Compressor 11</p> <p> Precautions for Service Equipment 11</p> <p> RECOVERY/RECYCLING EQUIPMENT 11</p> <p> ELECTRONIC LEAK DETECTOR 11</p> <p> VACUUM PUMP 12</p> <p> MANIFOLD GAUGE SET 12</p> <p> SERVICE HOSES 12</p> <p> SERVICE COUPLERS 13</p> <p> REFRIGERANT WEIGHT SCALE 13</p> <p> CHARGING CYLINDER 13</p> <p>PREPARATION 14</p> <p> Special Service Tools 14</p> <p> HFC-134a (R-134a) Service Tools and Equipment. 14</p> <p> Commercial Service Tools 17</p> <p>REFRIGERATION SYSTEM 18</p> <p> Refrigerant Cycle 18</p> <p> REFRIGERANT FLOW 18</p> <p> Refrigerant System Protection 18</p> <p> REFRIGERANT PRESSURE SENSOR 18</p> <p> PRESSURE RELIEF VALVE 19</p> <p> Component Layout 20</p> <p> FRONT REFRIGERATION SYSTEM 20</p> <p> REAR REFRIGERATION SYSTEM 21</p> <p>OIL 22</p> <p> Maintenance of Oil Quantity in Compressor 22</p> <p> OIL 22</p> <p> CHECKING AND ADJUSTING 22</p>	<p>AIR CONDITIONER CONTROL 25</p> <p> Description 25</p> <p> Operation 25</p> <p> AIR MIX DOORS CONTROL (AUTOMATIC TEMPERATURE CONTROL) 25</p> <p> BLOWER SPEED CONTROL 25</p> <p> INTAKE DOORS CONTROL 25</p> <p> MODE DOOR CONTROL 25</p> <p> DEFROSTER DOOR CONTROL 25</p> <p> MAGNET CLUTCH CONTROL 26</p> <p> SELF-DIAGNOSTIC SYSTEM 26</p> <p> Description of Control System 27</p> <p> Control Operation 27</p> <p> DISPLAY SCREEN 28</p> <p> AUTO SWITCH 28</p> <p> TEMPERATURE CONTROL DIAL (DRIVER SIDE) 28</p> <p> TEMPERATURE CONTROL DIAL (PASSENGER SIDE) 28</p> <p> REAR TEMPERATURE/MODE CONTROL DIAL (FRONT) 28</p> <p> REAR TEMPERATURE/MODE CONTROL DIAL (REAR) 28</p> <p> RECIRCULATION () SWITCH 28</p> <p> DEFROSTER () SWITCH 28</p> <p> REAR WINDOW DEFOGGER SWITCH 28</p> <p> OFF SWITCH 28</p> <p> A/C SWITCH 28</p> <p> MODE SWITCHES 29</p> <p> FRONT BLOWER CONTROL DIAL 29</p> <p> REAR BLOWER CONTROL DIAL (FRONT) 29</p> <p> REAR BLOWER CONTROL DIAL (REAR) 29</p> <p> Discharge Air Flow 29</p> <p> FRONT 29</p> <p> REAR 29</p> <p> System Description 30</p> <p> SWITCHES AND THEIR CONTROL FUNCTION.. 30</p> <p> CAN Communication System Description 31</p> <p>TROUBLE DIAGNOSIS 32</p> <p> CONSULT-II Function (HVAC) 32</p>
--	--

D
E

F
G

H
I

ATC

K
L

M

CONSULT-II START PROCEDURE	32	Intake Door Motor Circuit	86
SELF-DIAGNOSIS	32	INSPECTION FLOW	86
DATA MONITOR	33	SYSTEM DESCRIPTION	87
CONSULT-II Function (BCM)	35	COMPONENT DESCRIPTION	88
CONSULT-II START PROCEDURE	35	DIAGNOSTIC PROCEDURE FOR INTAKE	
DATA MONITOR	35	DOOR MOTOR (DRIVER)	88
How to Perform Trouble Diagnosis for Quick and		DIAGNOSTIC PROCEDURE FOR INTAKE	
Accurate Repair	36	DOOR MOTOR (PASSENGER)	90
WORK FLOW	36	Defroster Door Motor Circuit	92
SYMPTOM TABLE	36	SYMPTOM:	92
Component Parts and Harness Connector Location..	38	INSPECTION FLOW	92
ENGINE COMPARTMENT	38	SYSTEM DESCRIPTION	93
FRONT PASSENGER COMPARTMENT	39	COMPONENT DESCRIPTION	93
REAR PASSENGER COMPARTMENT	41	DIAGNOSTIC PROCEDURE FOR	
Schematic	42	DEFROSTER DOOR MOTOR	94
Wiring Diagram — A/C,A —	43	Front Blower Motor Circuit	96
Front Air Control Terminals and Reference Value..	51	INSPECTION FLOW	96
FRONT AIR CONTROL HARNESS CONNEC-		SYSTEM DESCRIPTION	97
TOR TERMINAL LAYOUT	51	COMPONENT DESCRIPTION	98
TERMINALS AND REFERENCE VALUES FOR		DIAGNOSTIC PROCEDURE FOR BLOWER	
FRONT AIR CONTROL	51	MOTOR	98
A/C System Self-diagnosis Function	53	COMPONENT INSPECTION	103
DESCRIPTION	53	Rear Blower Motor Circuit	105
Operational Check (Front)	55	INSPECTION FLOW	105
CHECKING MEMORY FUNCTION	55	SYSTEM DESCRIPTION	107
CHECKING BLOWER	55	COMPONENT DESCRIPTION	107
CHECKING DISCHARGE AIR	55	TROUBLE DIAGNOSIS PROCEDURE 1	108
CHECKING RECIRCULATION	55	TROUBLE DIAGNOSIS PROCEDURE 2	109
CHECKING TEMPERATURE DECREASE	55	TROUBLE DIAGNOSIS PROCEDURE 3	110
CHECKING TEMPERATURE INCREASE	56	TROUBLE DIAGNOSIS PROCEDURE 4	115
CHECK A/C SWITCH	56	COMPONENT INSPECTION	116
CHECKING AUTO MODE	56	Rear Air Temperature Control Circuit	118
Operational Check (Rear)	57	INSPECTION FLOW	118
CHECKING REAR BLOWER MOTOR	57	SYSTEM DESCRIPTION	119
CHECKING REAR DISCHARGE AIR	57	DIAGNOSTIC PROCEDURE FOR REAR AIR	
CHECKING REAR TEMPERATURE		CONTROL (FRONT)	119
DECREASE	57	DIAGNOSTIC PROCEDURE FOR REAR AIR	
CHECKING REAR TEMPERATURE INCREASE..	58	CONTROL (REAR)	122
Power Supply and Ground Circuit for Front Air Con-		Magnet Clutch Circuit	124
trol	59	INSPECTION FLOW	124
INSPECTION FLOW	59	SYSTEM DESCRIPTION	125
COMPONENT DESCRIPTION	60	DIAGNOSTIC PROCEDURE FOR MAGNET	
DIAGNOSTIC PROCEDURE FOR A/C SYSTEM..	60	CLUTCH	125
Mode Door Motor Circuit	62	Insufficient Cooling	130
INSPECTION FLOW	62	INSPECTION FLOW	130
SYSTEM DESCRIPTION	64	PERFORMANCE TEST DIAGNOSES	132
COMPONENT DESCRIPTION	65	PERFORMANCE CHART	134
DIAGNOSTIC PROCEDURE FOR MODE		TROUBLE DIAGNOSES FOR UNUSUAL PRES-	
DOOR MOTOR	65	SURE	135
Air Mix Door Motor Circuit	70	Insufficient Heating	138
INSPECTION FLOW	70	INSPECTION FLOW	138
SYSTEM DESCRIPTION	72	Heater Pump Circuit	140
COMPONENT DESCRIPTION	73	SYSTEM DESCRIPTION	140
DIAGNOSTIC PROCEDURE FOR AIR MIX		DIAGNOSTIC PROCEDURE FOR HEATER	
DOOR MOTOR (DRIVER)	73	PUMP CIRCUIT	141
DIAGNOSTIC PROCEDURE FOR AIR MIX		COMPONENT INSPECTION	142
DOOR MOTOR (PASSENGER)	77	Noise	143
DIAGNOSTIC PROCEDURE FOR AIR MIX		INSPECTION FLOW	143
DOOR MOTOR (REAR)	81	Self-diagnosis	145

INSPECTION FLOW	145	BLY	171	
Memory Function	147	HEATER CORE	172	A
INSPECTION FLOW	147	Components	172	
Ambient Sensor Circuit	148	Removal and Installation	173	B
COMPONENT DESCRIPTION	148	FRONT HEATER CORE	173	
AMBIENT TEMPERATURE INPUT PROCESS	148	REAR HEATER CORE	174	
DIAGNOSTIC PROCEDURE FOR AMBIENT		HEATER PUMP	175	C
SENSOR	148	Removal and Installation	175	
COMPONENT INSPECTION	150	REMOVAL	175	
In-vehicle Sensor Circuit	151	INSTALLATION	175	D
COMPONENT DESCRIPTION	151	DEFROSTER DOOR MOTOR	176	
DIAGNOSTIC PROCEDURE FOR IN-VEHICLE		Removal and Installation	176	
SENSOR	152	REMOVAL	176	
COMPONENT INSPECTION	154	INSTALLATION	176	E
Optical Sensor Circuit	155	INTAKE DOOR MOTOR	177	
COMPONENT DESCRIPTION	155	Components	177	
OPTICAL INPUT PROCESS	155	Removal and Installation	178	F
DIAGNOSTIC PROCEDURE FOR OPTICAL		DRIVER SIDE	178	
SENSOR	155	PASSENGER SIDE	179	
Intake Sensor Circuit	158	MODE DOOR MOTOR	180	G
COMPONENT DESCRIPTION	158	Removal and Installation	180	
DIAGNOSTIC PROCEDURE FOR INTAKE SEN-		REMOVAL	180	
SOR	158	INSTALLATION	181	H
COMPONENT INSPECTION	159	AIR MIX DOOR MOTOR	182	
CONTROL UNIT	160	Components	182	
Removal and Installation	160	Removal and Installation	183	I
FRONT AIR CONTROL	160	FRONT AIR MIX DOOR MOTOR (DRIVER)	183	
REAR AIR CONTROL (FRONT)	160	FRONT AIR MIX DOOR MOTOR (PASSENGER)	184	
REAR AIR CONTROL (REAR)	160	REAR AIR MIX DOOR MOTOR	184	
AMBIENT SENSOR	162	VARIABLE BLOWER CONTROL	185	ATC
Removal and Installation	162	Components	185	
REMOVAL	162	Removal and Installation	186	
INSTALLATION	162	VARIABLE BLOWER CONTROL (FRONT)	186	
IN-VEHICLE SENSOR	163	VARIABLE BLOWER CONTROL (REAR)	186	K
Removal and Installation	163	DUCTS AND GRILLES	187	
REMOVAL	163	Components	187	
INSTALLATION	163	Removal and Installation	190	L
OPTICAL SENSOR	164	DEFROSTER NOZZLE	190	
Removal and Installation	164	FRESH AIR DUCT	190	
INTAKE SENSOR	165	DEFROSTER DUCT	190	
Removal and Installation	165	RH AND LH SIDE DEMISTER DUCT	190	M
REMOVAL	165	RH, LH, AND CENTER VENTILATOR DUCT ..	190	
INSTALLATION	165	FLOOR CONNECTOR DUCT	190	
BLOWER MOTOR	166	FLOOR DISTRIBUTION DUCT	191	
Components	166	FLOOR JUNCTION DUCT	191	
Removal and Installation	167	FLOOR JUNCTION DUCT EXTENSION	191	
FRONT BLOWER MOTOR	167	FLOOR DUCT	191	
REAR BLOWER MOTOR	167	REAR OVERHEAD DUCT	191	
IN-CABIN MICROFILTER	168	REAR FLOOR DUCT	191	
Removal and Installation	168	GRILLES	191	
FUNCTION	168	REFRIGERANT LINES	193	
REPLACEMENT TIMING	168	HFC-134a (R-134a) Service Procedure	193	
REPLACEMENT PROCEDURES	168	SETTING OF SERVICE TOOLS AND EQUIP-		
HEATER & COOLING UNIT ASSEMBLY	169	MENT	193	
Components	169	Components	195	
Removal and Installation	170	Removal and Installation for Compressor	197	
FRONT HEATER AND COOLING UNIT ASSEM-		REMOVAL	197	
BLY	170	INSTALLATION	197	
REAR HEATER AND COOLING UNIT ASSEM-		Removal and Installation for Compressor Clutch ..	198	

REMOVAL	198	REMOVAL	208
INSPECTION	199	INSTALLATION	209
INSTALLATION	199	Removal and Installation for Rear Evaporator	210
BREAK-IN OPERATION	201	REMOVAL	210
Removal and Installation for Low-pressure Flexible		INSTALLATION	211
Hose	201	Removal and Installation for Front Expansion Valve	211
REMOVAL	201	REMOVAL	211
INSTALLATION	201	INSTALLATION	211
Removal and Installation for High-pressure Flexible		Removal and Installation for Rear Expansion Valve	211
Hose	201	REMOVAL	211
REMOVAL	201	INSTALLATION	211
INSTALLATION	201	Checking for Refrigerant Leaks	212
Removal and Installation for High-pressure Pipe	202	Checking System for Leaks Using the Fluorescent	
REMOVAL	202	Dye Leak Detector	212
INSTALLATION	202	Dye Injection	212
Removal and Installation for High/Low-pressure		Electronic Refrigerant Leak Detector	213
Pipe	202	PRECAUTIONS FOR HANDLING LEAK	
REMOVAL	202	DETECTOR	213
INSTALLATION	204	CHECKING PROCEDURE	214
Removal and Installation for Refrigerant Pressure		SERVICE DATA AND SPECIFICATIONS (SDS) ...216	
Sensor	206	Service Data and Specifications (SDS)	216
REMOVAL	206	COMPRESSOR	216
INSTALLATION	206	OIL	216
Removal and Installation for Condenser	206	REFRIGERANT	216
REMOVAL	206	ENGINE IDLING SPEED	216
INSTALLATION	207	BELT TENSION	216
Removal and Installation for Front Evaporator	208		

PRECAUTIONS

PRECAUTIONS

PFP:00001

Precautions for Supplemental Restraint System (SRS) “AIR BAG” and “SEAT BELT PRE-TENSIONER”

EJS004J5

The Supplemental Restraint System such as “AIR BAG” and “SEAT BELT PRE-TENSIONER”, used along with a front seat belt, helps to reduce the risk or severity of injury to the driver and front passenger for certain types of collision. This system includes seat belt switch inputs and dual stage front air bag modules. The SRS system uses the seat belt switches to determine the front air bag deployment, and may only deploy one front air bag, depending on the severity of a collision and whether the front occupants are belted or unbelted. Information necessary to service the system safely is included in the SRS and SB section of this Service Manual.

WARNING:

- To avoid rendering the SRS inoperative, which could increase the risk of personal injury or death in the event of a collision which would result in air bag inflation, all maintenance must be performed by an authorized NISSAN/INFINITI dealer.
- Improper maintenance, including incorrect removal and installation of the SRS, can lead to personal injury caused by unintentional activation of the system. For removal of Spiral Cable and Air Bag Module, see the SRS section.
- Do not use electrical test equipment on any circuit related to the SRS unless instructed to in this Service Manual. SRS wiring harnesses can be identified by yellow and/or orange harnesses or harness connectors.

Precautions for Working with HFC-134a (R-134a)

EJS004J6

WARNING:

- CFC-12 (R-12) refrigerant and HFC-134a (R-134a) refrigerant are not compatible. If the refrigerants are mixed compressor failure is likely to occur. Refer [ATC-5, "Contaminated Refrigerant"](#) . To determine the purity of HFC-134a (R-134a) in the vehicle and recovery tank, use refrigerant recovery/recycling equipment and refrigerant identifier.
- Use only specified oil for the HFC-134a (R-134a) A/C system and HFC-134a (R-134a) components. If oil other than that specified is used, compressor failure is likely to occur.
- The specified HFC-134a (R-134a) oil rapidly absorbs moisture from the atmosphere. The following handling precautions must be observed:
 - When removing refrigerant components from a vehicle, immediately cap (seal) the component to minimize the entry of moisture from the atmosphere.
 - When installing refrigerant components to a vehicle, do not remove the caps (unseal) until just before connecting the components. Connect all refrigerant loop components as quickly as possible to minimize the entry of moisture into system.
 - Only use the specified oil from a sealed container. Immediately reseal containers of oil. Without proper sealing, oil will become moisture saturated and should not be used.
 - Avoid breathing A/C refrigerant and oil vapor or mist. Exposure may irritate eyes, nose and throat. Remove HFC-134a (R-134a) from the A/C system using certified service equipment meeting requirements of SAE J2210 [HFC-134a (R-134a) recycling equipment], or SAE J2209 [HFC-134a (R-134a) recovery equipment]. If accidental system discharge occurs, ventilate work area before resuming service. Additional health and safety information may be obtained from refrigerant and oil manufacturers.
 - Do not allow refrigerant oil to come in contact with styrofoam parts. Damage may result.

Contaminated Refrigerant

EJS004J7

If a refrigerant other than pure HFC-134a (R-134a) is identified in a vehicle, your options are:

- Explain to the customer that environmental regulations prohibit the release of contaminated refrigerant into the atmosphere.
- Explain that recovery of the contaminated refrigerant could damage your service equipment and refrigerant supply.
- Suggest the customer return the vehicle to the location of previous service where the contamination may have occurred.
- If you choose to perform the repair, recover the refrigerant using only **dedicated equipment and containers**. **Do not recover contaminated refrigerant into your existing service equipment**. If your facility

PRECAUTIONS

does not have dedicated recovery equipment, you may contact a local refrigerant product retailer for available service. This refrigerant must be disposed of in accordance with all federal and local regulations. In addition, replacement of all refrigerant system components on the vehicle is recommended.

- If the vehicle is within the warranty period, the air conditioner warranty is void. Please contact NISSAN Customer Affairs for further assistance.

General Refrigerant Precautions

EJS004JB

WARNING:

- Do not release refrigerant into the air. Use approved recovery/recycling equipment to capture the refrigerant every time an air conditioning system is discharged.
- Always wear eye and hand protection (goggles and gloves) when working with any refrigerant or air conditioning system.
- Do not store or heat refrigerant containers above 52°C (125°F).
- Do not heat a refrigerant container with an open flame; if container warming is required, place the bottom of the container in a warm pail of water.
- Do not intentionally drop, puncture, or incinerate refrigerant containers.
- Keep refrigerant away from open flames: poisonous gas will be produced if refrigerant burns.
- Refrigerant will displace oxygen, therefore be certain to work in well ventilated areas to prevent suffocation.
- Do not pressure test or leak test HFC-134a (R-134a) service equipment and/or vehicle air conditioning systems with compressed air during repair. Some mixtures of air and HFC-134a (R-134a) have been shown to be combustible at elevated pressures. These mixtures, if ignited, may cause injury or property damage. Additional health and safety information may be obtained from refrigerant manufacturers.

Precautions for Leak Detection Dye

EJS004J9

- The A/C system contains a fluorescent leak detection dye used for locating refrigerant leaks. An ultraviolet (UV) lamp is required to illuminate the dye when inspecting for leaks.
- Always wear fluorescence enhancing UV safety glasses to protect your eyes and enhance the visibility of the fluorescent dye.
- The fluorescent dye leak detector is not a replacement for an electronic refrigerant leak detector. The fluorescent dye leak detector should be used in conjunction with an electronic refrigerant leak detector (J-41995).
- For your safety and the customer's satisfaction, read and follow all manufacturer's operating instructions and precautions prior to performing work.
- A compressor shaft seal should not be repaired because of dye seepage. The compressor shaft seal should only be repaired after confirming the leak with an electronic refrigerant leak detector (J-41995).
- Always remove any dye from the leak area after repairs are complete to avoid a misdiagnosis during a future service.
- Do not allow dye to come into contact with painted body panels or interior components. If dye is spilled, clean immediately with the approved dye cleaner. Fluorescent dye left on a surface for an extended period of time **cannot be removed**.
- Do not spray the fluorescent dye cleaning agent on hot surfaces (engine exhaust manifold, etc.).
- Do not use more than one refrigerant dye bottle (1/4 ounce / 7.4 cc) per A/C system.
- Leak detection dyes for HFC-134a (R-134a) and CFC-12 (R-12) A/C systems are different. Do not use HFC-134a (R-134a) leak detection dye in CFC-12 (R-12) A/C systems or CFC-12 (R-12) leak detection dye in HFC-134A (R-134a) A/C systems or A/C system damage may result.
- The fluorescent properties of the dye will remain for over three (3) years unless a compressor failure occurs.

A/C Identification Label

EJS004JA

Vehicles with factory installed fluorescent dye have an identification label on the underside of hood.

Precautions for Refrigerant Connection

EJS004JB

A new type refrigerant connection has been introduced to all refrigerant lines except the following locations.

PRECAUTIONS

- Expansion valve to cooling unit
- Evaporator pipes to evaporator (inside cooling unit)
- Refrigerant pressure sensor

FEATURES OF NEW TYPE REFRIGERANT CONNECTION

- The O-ring has been relocated. It has also been provided with a groove for proper installation. This reduces the possibility of the O-ring being caught in, or damaged by, the mating part. The sealing direction of the O-ring is now set vertically in relation to the contacting surface of the mating part to improve sealing characteristics.
- The reaction force of the O-ring will not occur in the direction that causes the joint to pull out, thereby facilitating piping connections.

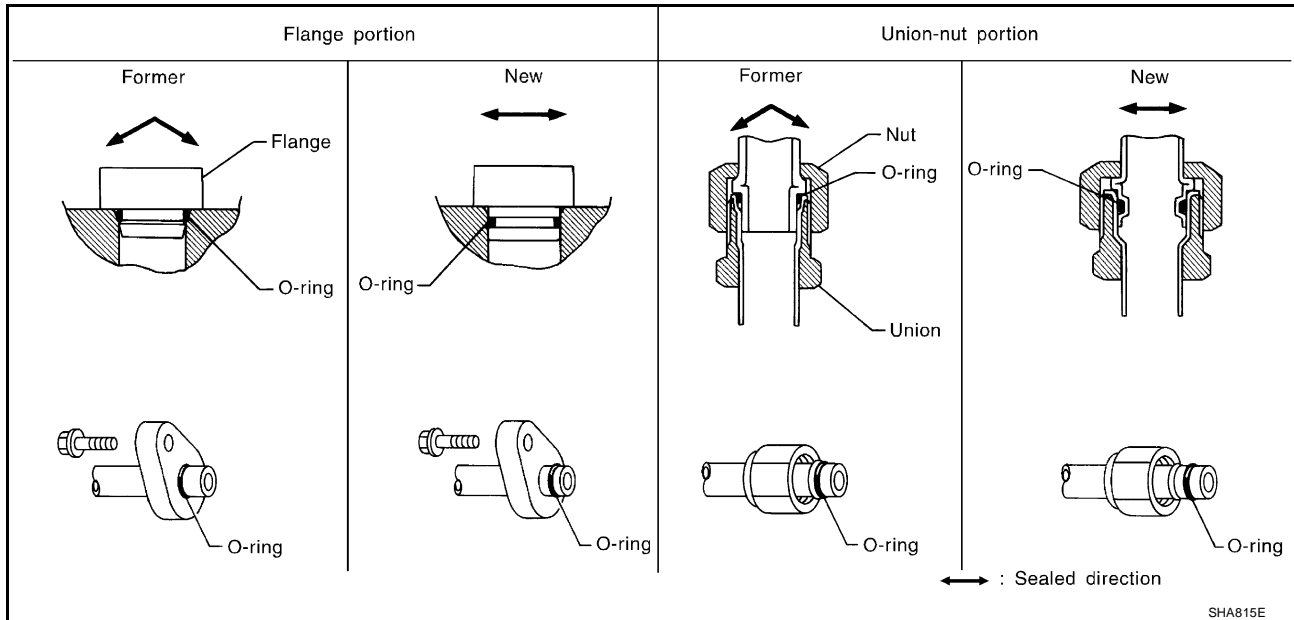

A
B
C
D
E
F
G
H
I
K
L
M

ATC

PRECAUTIONS

O-RING AND REFRIGERANT CONNECTION

Front A/C Compressor and Condenser

SEC. 214 • 271 • 274 • 276

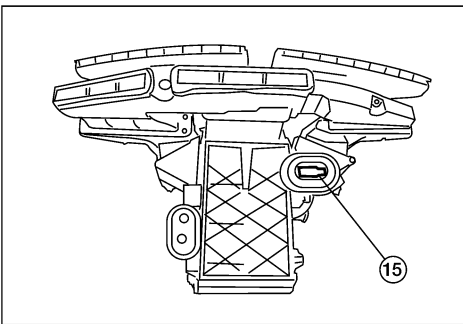
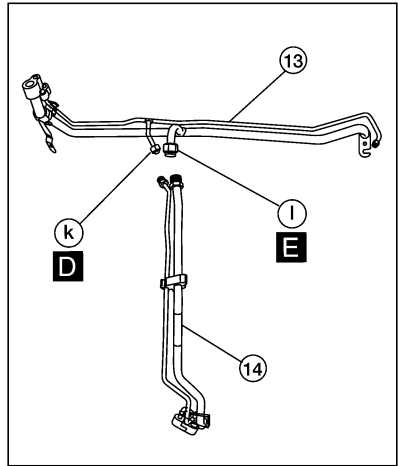
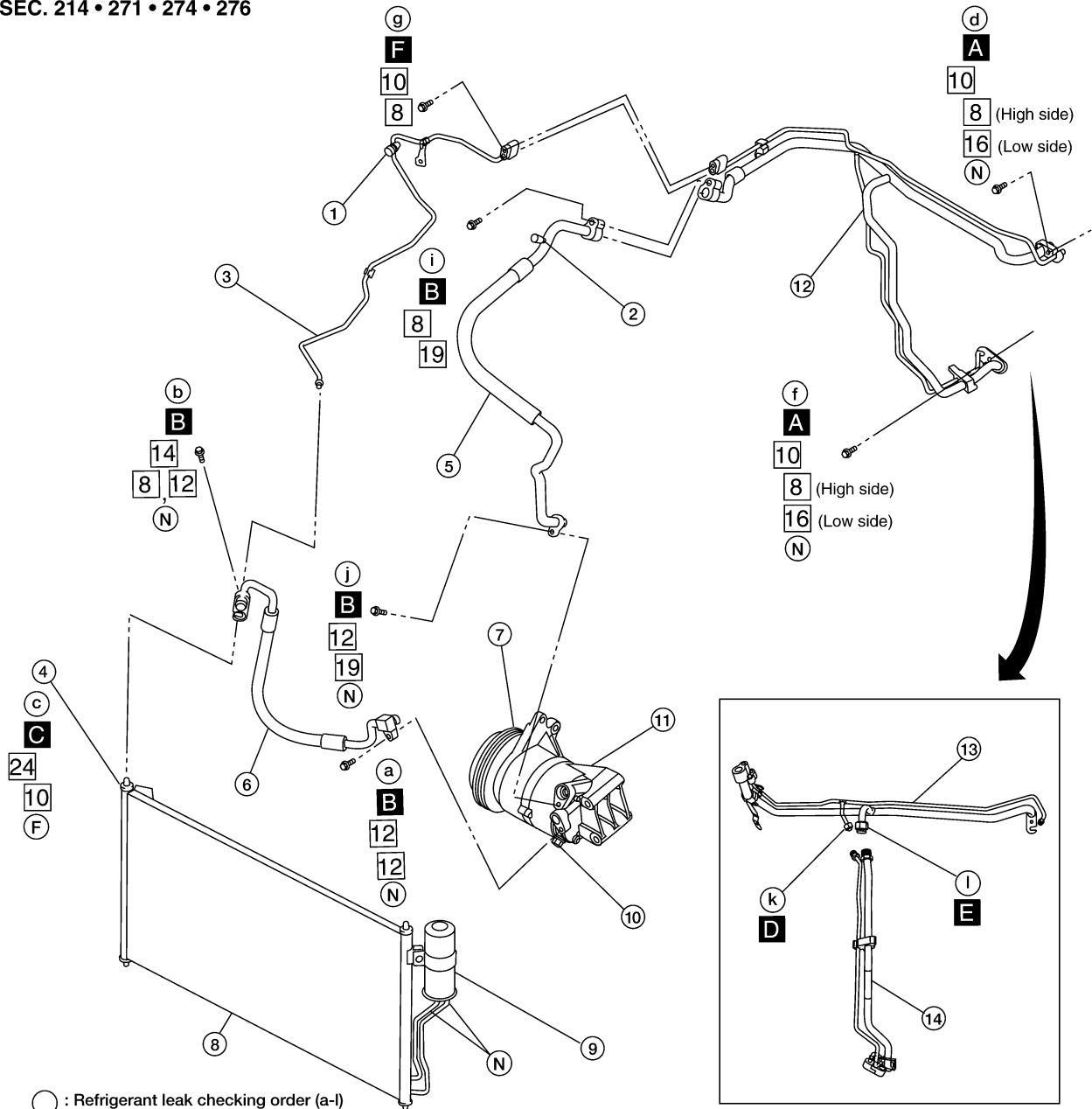

- : Refrigerant leak checking order (a-l)
- : Tightening torque
- : Wrench size
- : O-ring size
- ⊗ : N-m (kg-m, in-lb)
- ⊗ : N-m (kg-m, ft-lb)
- A** ⊗ : 6.8 (0.69 , 60)
- B** ⊗ : 14.2 (1.4 , 10)
- C** ⊗ : 10.8 (1.1 , 8)
- D** ⊗ : 18 (1.8 , 13)
- E** ⊗ : 31 (3.2 , 23)
- F** ⊗ : 5.7 (0.58 , 50)
- ⊗ : Former type refrigerant connection
- ⊗ : New type refrigerant connection

WJIA1967E

PRECAUTIONS

- | | | |
|--|--|---|
| 1. High-pressure service valve | 2. Low-pressure service valve | 3. High-pressure pipe |
| 4. Refrigerant pressure sensor | 5. Low-pressure flexible hose | 6. High-pressure flexible hose |
| 7. Shaft seal | 8. Condenser | 9. Liquid tank |
| 10. Pressure relief valve | 11. Compressor | 12. High/low pressure pipe (production) |
| 13. High/low pressure pipe - upper (service) | 14. High/low pressure pipe - lower (service) | 15. Expansion valve (front) |

Rear A/C

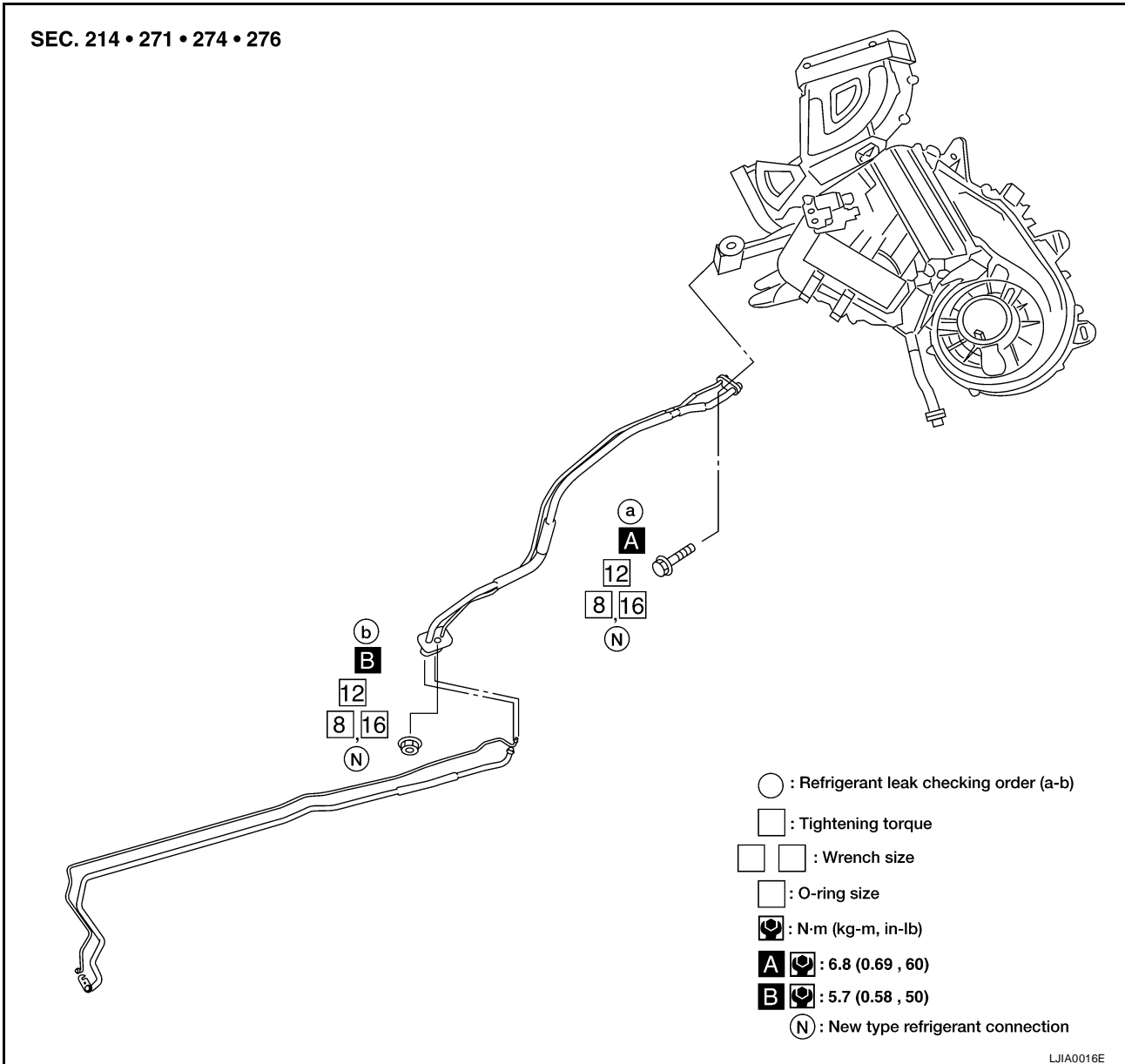

CAUTION:

The new and former refrigerant connections use different O-ring configurations. Do not confuse O-rings since they are not interchangeable. If a wrong O-ring is installed, refrigerant will leak at or around the connection.

A
B
C
D
E
F
G
H
I
ATC
K
L
M

PRECAUTIONS

O-Ring Part Numbers and Specifications

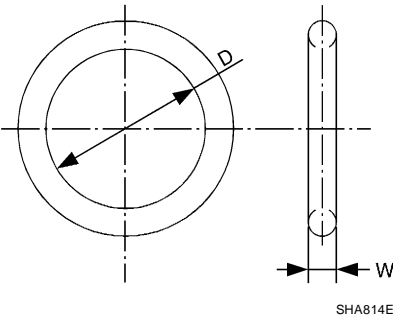
	Conne- tion type	O-ring size	Part number*	D mm (in)	W mm (in)
	New	8	92471 N8210	6.8 (0.268)	1.85 (0.0728)
Former	10	J2476 89956	9.25 (0.3642)	1.78 (0.0701)	
New	12	92472 N8210	10.9 (0.429)	2.43 (0.0957)	
Former		92475 71L00	11.0 (0.433)	2.4 (0.094)	
New	16	92473 N8210	13.6 (0.535)	2.43 (0.0957)	
Former		92475 72L00	14.3 (0.563)	2.3 (0.091)	
New	19	92474 N8210	16.5 (0.650)	2.43 (0.0957)	
Former		92477 N8200	17.12 (0.6740)	1.78 (0.0701)	
New	24	92195 AH300	21.8 (0.858)	2.4 (0.094)	

*: Always check with the Parts Department for the latest parts information.

WARNING:

Make sure all refrigerant is discharged into the recycling equipment and the pressure in the system is less than atmospheric pressure. Then gradually loosen the discharge side hose fitting and remove it.

CAUTION:

When replacing or cleaning refrigerant cycle components, observe the following.

- **When the compressor is removed, store it in the same position as it is when mounted on the car. Failure to do so will cause oil to enter the low pressure chamber.**
- **When connecting tubes, always use a torque wrench and a back-up wrench.**
- **After disconnecting tubes, immediately plug all openings to prevent entry of dirt and moisture.**
- **When installing an air conditioner in the vehicle, connect the pipes as the final stage of the operation. Do not remove the seal caps of pipes and other components until just before required for connection.**
- **Allow components stored in cool areas to warm to working area temperature before removing seal caps. This prevents condensation from forming inside A/C components.**
- **Thoroughly remove moisture from the refrigeration system before charging the refrigerant.**
- **Always replace used O-rings.**
- **When connecting tube, apply oil to circle of the O-rings shown in illustration. Be careful not to apply oil to threaded portion.**
- **O-ring must be closely attached to dented portion of tube.**
- **When replacing the O-ring, be careful not to damage O-ring and tube.**
- **Connect tube until you hear it click, then tighten the nut or bolt by hand until snug. Make sure that the O-ring is installed to tube correctly.**
- **After connecting line, conduct leak test and make sure that there is no leakage from connections. When the gas leaking point is found, disconnect that line and replace the O-ring. Then tighten connections of seal seat to the specified torque.**

PRECAUTIONS

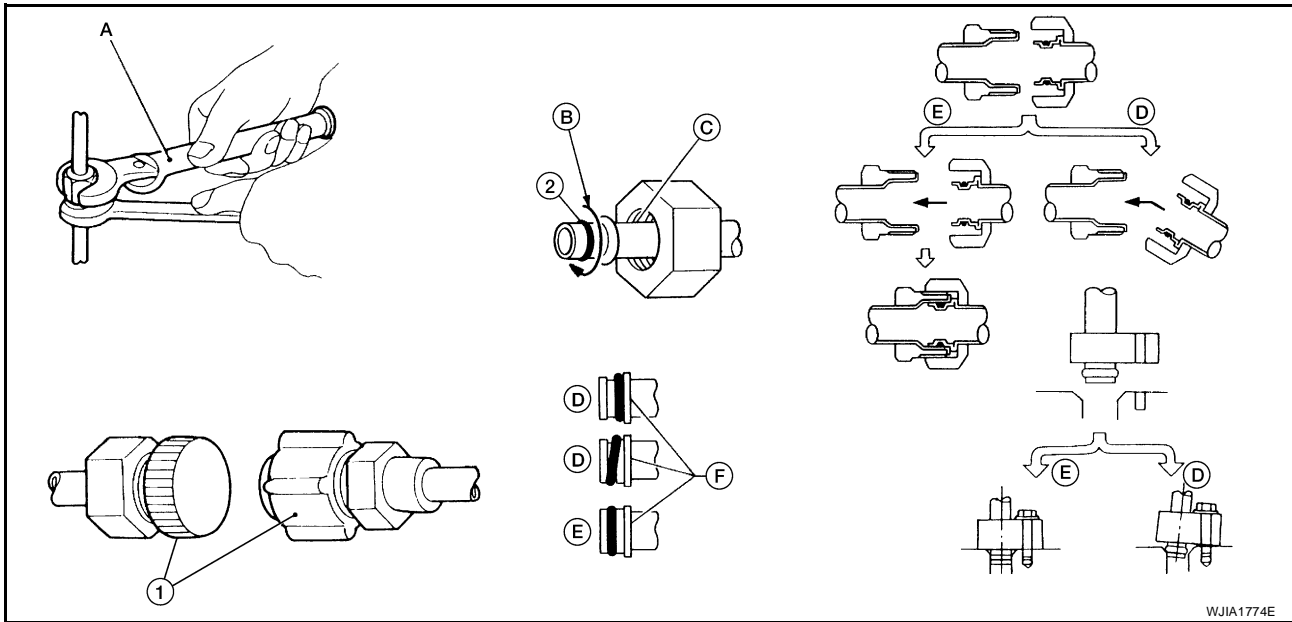

- | | | |
|--------------|--------------------------------|------------------|
| 1. Plug | 2. O-ring | A. Torque wrench |
| B. Apply oil | C. Do not apply oil to threads | D. NG (no good) |
| E. OK (okay) | F. Inflated portion | |

Precautions for Servicing Compressor

EJS004JC

- Plug all openings to prevent moisture and foreign matter from entering.
- When the compressor is removed, store it in the same position as it is when mounted on the car.
- When replacing or repairing compressor, follow "Maintenance of Oil Quantity in Compressor" exactly. Refer to [ATC-22, "Maintenance of Oil Quantity in Compressor"](#).
- Keep friction surfaces between clutch and pulley clean. If the surface is contaminated with oil, wipe it off by using a clean waste cloth moistened with thinner.
- After compressor service operation, turn the compressor shaft by hand more than 5 turns in both directions. This will equally distribute oil inside the compressor. After the compressor is installed, let the engine idle and operate the compressor for 1 hour.
- After replacing the compressor magnet clutch, apply voltage to the new one and check for normal operation. Refer to [ATC-198, "Removal and Installation for Compressor Clutch"](#).

Precautions for Service Equipment RECOVERY/RECYCLING EQUIPMENT

EJS004JD

Follow the manufacturer's instructions for machine operation and machine maintenance. Never introduce any refrigerant other than that specified into the machine.

ELECTRONIC LEAK DETECTOR

Follow the manufacturer's instructions for tester operation and tester maintenance.

PRECAUTIONS

VACUUM PUMP

The oil contained inside the vacuum pump is not compatible with the specified oil for HFC-134a (R-134a) A/C systems. The vent side of the vacuum pump is exposed to atmospheric pressure so the vacuum pump oil may migrate out of the pump into the service hose. This is possible when the pump is switched off after evacuation (vacuuming) and hose is connected to it.

To prevent this migration, use a manual valve situated near the hose-to-pump connection, as follows.

- Usually vacuum pumps have a manual isolator valve as part of the pump. Close this valve to isolate the service hose from the pump.
- For pumps without an isolator, use a hose equipped with a manual shut-off valve near the pump end. Close the valve to isolate the hose from the pump.
- If the hose has an automatic shut off valve, disconnect the hose from the pump: as long as the hose is connected, the valve is open and lubricating oil may migrate.

Some one-way valves open when vacuum is applied and close under a no vacuum condition. Such valves may restrict the pump's ability to pull a deep vacuum and are not recommended.

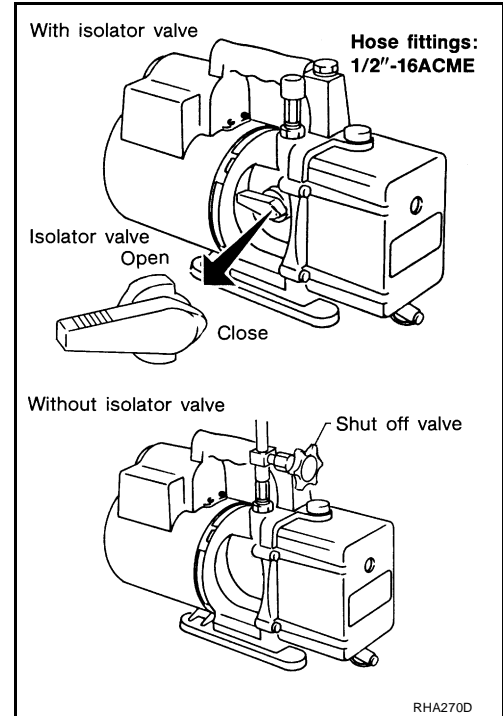

MANIFOLD GAUGE SET

Be certain that the gauge face indicates HFC-134a (R-134a or 134a). Make sure the gauge set has 1/2"-16 ACME threaded connections for service hoses. Confirm the set has been used only with refrigerant HFC-134a (R-134a) along with specified oil.

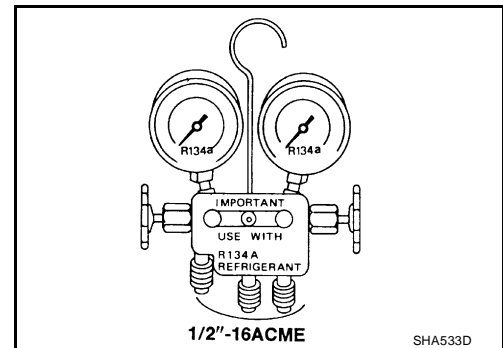

SERVICE HOSES

Be certain that the service hoses display the markings described (colored hose with black stripe). All hoses must include positive shut-off devices (either manual or automatic) near the end of the hoses opposite the manifold gauge.

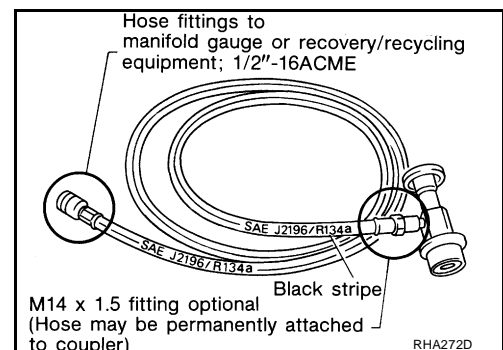

PRECAUTIONS

SERVICE COUPLERS

Never attempt to connect HFC-134a (R-134a) service couplers to a CFC-12 (R-12) A/C system. The HFC-134a (R-134a) couplers will not properly connect to the CFC-12 (R-12) system. If an improper connection is attempted, discharging and contamination may occur.

Shut-off valve rotation	A/C service valve
Clockwise	Open
Counterclockwise	Close

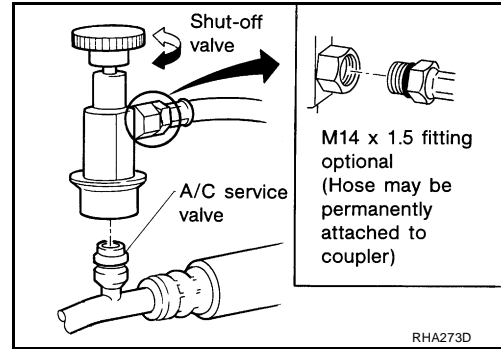

REFRIGERANT WEIGHT SCALE

Verify that no refrigerant other than HFC134a (R-134a) and specified oils have been used with the scale. If the scale controls refrigerant flow electronically, the hose fitting must be 1/2"-16 ACME.

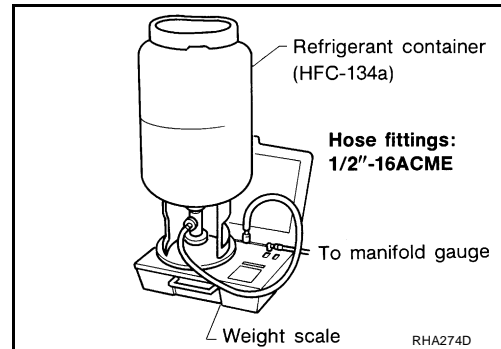

CHARGING CYLINDER

Using a charging cylinder is not recommended. Refrigerant may be vented into air from cylinder's top valve when filling the cylinder with refrigerant. Also, the accuracy of the cylinder is generally less than that of an electronic scale or of quality recycle/recharge equipment.

A
B
C
D
E
F
G
H
I
K
L
M

ATC

PREPARATION

PREPARATION

PF0:00002

Special Service Tools

EJS004JF

The actual shapes of Kent-Moore tools may differ from those of special service tools illustrated here.

Tool number (Kent-Moore No.) Tool name	Description
— (J-38873-A) Pulley installer	Installing pulley
KV99233130 (J-29884) Pulley puller	Removing pulley

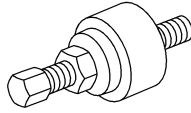

LHA171

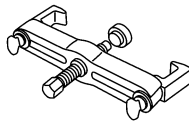

LHA172

HFC-134a (R-134a) Service Tools and Equipment

EJS004JG

Never mix HFC-134a refrigerant and/or its specified oil with CFC-12 (R-12) refrigerant and/or its oil. Separate and non-interchangeable service equipment must be used for handling each type of refrigerant/oil. Refrigerant container fittings, service hose fittings and service equipment fittings (equipment which handles refrigerant and/or oil) are different between CFC-12 (R-12) and HFC-134a (R-134a). This is to avoid mixed use of the refrigerants/oil. Adapters that convert one size fitting to another must never be used refrigerant/oil contamination will occur and compressor failure will result.

Tool number (Kent-Moore No.) Tool name	Description
HFC-134a (R-134a) (—) Refrigerant	Container color: Light blue Container marking: HFC-134a (R-134a) Fitting size: Thread size ● large container 1/2"-16 ACME
— (—) NISSAN A/C System Oil Type S	Type: Poly alkylene glycol oil (PAG), type S Application: HFC-134a (R-134a) vane rotary compressors (NISSAN only) Lubricity: 40 m ℓ (1.4 US fl oz, 1.4 Imp fl oz)
KV991J0130 (ACR2005-NI) ACR5 A/C Service Center	Refrigerant recovery, recycling and re-charging

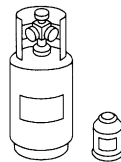

S-NT196







S-NT197

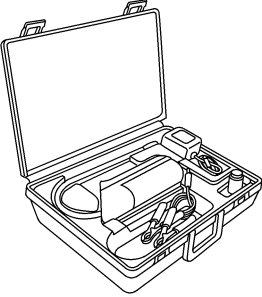
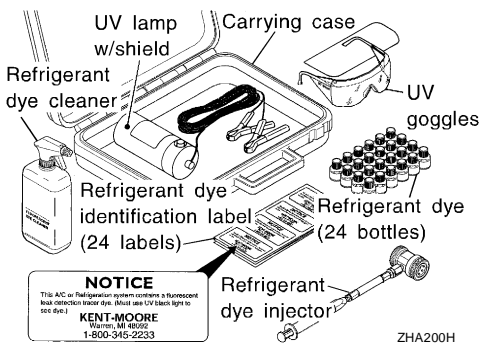
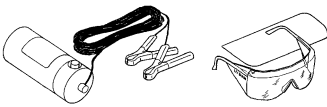

WJIA0293E

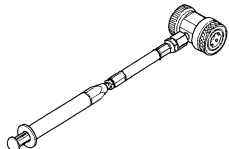
PREPARATION

Tool number (Kent-Moore No.) Tool name	Description
<p>— (J-41995) Electronic refrigerant leak detector</p>	<p>Checking for refrigerant leaks (Power supply: DC 12V battery terminal)</p> <div style="text-align: center;">  <p>AHA281A</p> </div>
<p>— (J-43926) Refrigerant dye leak detection kit Kit includes: (J-42220) UV lamp and UV safety goggles (J-41459) Refrigerant dye injector (J-41447) Quantity 24, 1/4 ounce bottles of HFC-134a (R-134a) fluorescent leak detection dye (J-43872) Refrigerant dye cleaner</p>	<p>Leak detection dye (Power supply: DC 12V battery terminal)</p> <div style="text-align: center;">  <p>ZHA200H</p> </div>
<p>— (J-42220) Fluorescent dye leak detector</p>	<p>Checking for refrigerant leaks when fluorescent dye is installed in A/C system. Includes: UV lamp and UV safety goggles (Power supply: DC 12V battery terminal)</p> <div style="text-align: center;">  <p>SHA438F</p> </div>
<p>— (J-41447) HFC-134a (R-134a) fluorescent leak detection dye (Box of 24, 1/4 ounce bottles)</p>	<p>Application: For HFC-134a (R-134a) PAG oil Container: 1/4 ounce (7.4cc) bottle (Includes self-adhesive dye identification labels for affixing to vehicle after charging system with dye.)</p> <div style="text-align: center;">  <p>SHA439F</p> </div>
<p>— (J-41459) HFC-134a (R-134a) Dye injector Use with (J-41447) 1/4 ounce bottles</p>	<p>For injecting 1/4 ounce of fluorescent leak detection dye into A/C system.</p> <div style="text-align: center;">  <p>SHA440F</p> </div>
<p>— (J-43872) Refrigerant dye cleaner</p>	<p>For cleaning dye spills.</p> <div style="text-align: center;">  <p>SHA441F</p> </div>

A
B
C
D
E
F
G
H
I
K
L
M

ATC

PREPARATION

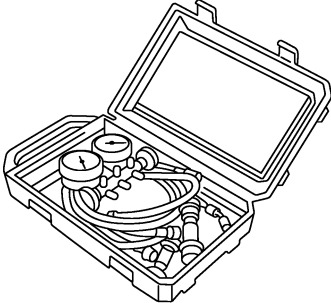
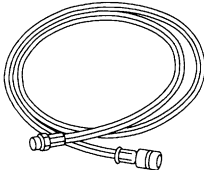
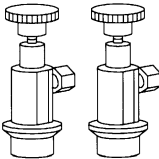
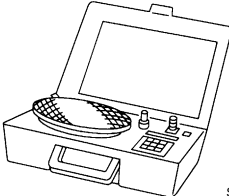
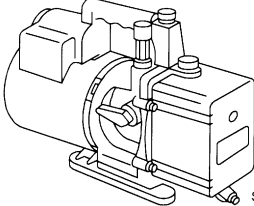
Tool number (Kent-Moore No.) Tool name	Description
<p>— (J-39183-C) Manifold gauge set (with hoses and couplers)</p>  <p style="text-align: right; font-size: small;">RJIA0196E</p>	<p>Identification:</p> <ul style="list-style-type: none"> ● The gauge face indicates R-134a. <li style="padding-left: 20px;">Fitting size: Thread size ● 1/2"-16 ACME
<p>Service hoses:</p> <ul style="list-style-type: none"> ● (J-39500-72B) High side hose ● (J-39500-72R) Low side hose ● (J-39500-72Y) Utility hose  <p style="text-align: right; font-size: small;">S-NT201</p>	<p>Hose colors:</p> <ul style="list-style-type: none"> ● Low side hose: Blue with black stripe ● High side hose: Red with black stripe ● Utility hose: Yellow with black stripe or green with black stripe <p>Hose fitting to gauge:</p> <ul style="list-style-type: none"> ● 1/2"-16 ACME
<p>Service couplers:</p> <ul style="list-style-type: none"> ● (J-39500-20A) High side coupler ● (J-39500-24A) Low side coupler  <p style="text-align: right; font-size: small;">S-NT202</p>	<p>Hose fitting to service hose:</p> <ul style="list-style-type: none"> ● M14 x 1.5 fitting is optional or permanently attached.
<p>— (J-39699) Refrigerant weight scale</p>  <p style="text-align: right; font-size: small;">S-NT200</p>	<p>For measuring of refrigerant Fitting size - thread size:</p> <ul style="list-style-type: none"> ● 1/2" - 16 ACME
<p>— (J-39649) Vacuum pump (Including the isolator valve)</p>  <p style="text-align: right; font-size: small;">S-NT203</p>	<p>Capacity:</p> <ul style="list-style-type: none"> ● Air displacement: 4 CFM ● Micron rating: 20 microns ● Oil capacity: 482 g (17 oz) <p>Fitting size: Thread size</p> <ul style="list-style-type: none"> ● 1/2"-16 ACME

PREPARATION

Commercial Service Tools

EJS004JH

Tool number Tool name	Description
(J-41810-NI) Refrigerant identifier equipment (R-134a)	For checking refrigerant purity and system contamination
Power tool	Loosening bolts and nuts
(J-44614) Clutch disc holding tool	Clutch disc holding tool

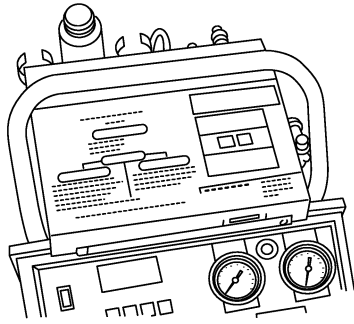

RJIA0197E

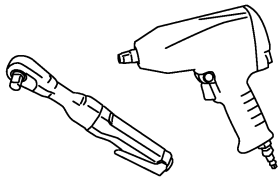

PBIC0190E

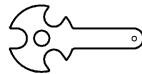

WHA230

A
B
C
D
E
F
G
H
I
K
L
M

ATC

REFRIGERATION SYSTEM

REFRIGERATION SYSTEM

PPF:KA990

Refrigerant Cycle REFRIGERANT FLOW

EJS004JI

The refrigerant flows in the standard pattern, that is, through the compressor, the condenser with liquid tank, through the front and rear evaporators, and back to the compressor. The refrigerant evaporation through the evaporator coils are controlled by a front and rear externally equalized expansion valves, located inside the front and rear evaporator cases.

Refrigerant System Protection REFRIGERANT PRESSURE SENSOR

EJS004JJ

The refrigerant system is protected against excessively high or low pressures by the refrigerant pressure sensor, located on the condenser. If the system pressure rises above or falls below the specifications, the refrigerant pressure sensor detects the pressure inside the refrigerant line and sends a voltage signal to the ECM. The ECM de-energizes the A/C relay to disengage the magnetic compressor clutch when pressure on the high pressure side detected by refrigerant pressure sensor is over about 2,746 kPa (28 kg/cm² , 398 psi), or below about 120 kPa (1.22 kg/cm² , 17.4 psi).

REFRIGERATION SYSTEM

PRESSURE RELIEF VALVE

The refrigerant system is also protected by a pressure relief valve, located in the rear head of the compressor. When the pressure of refrigerant in the system increases to an abnormal level [more than 2,990 kPa (30.5 kg/cm² , 433.6 psi)], the release port on the pressure relief valve automatically opens and releases refrigerant into the atmosphere.

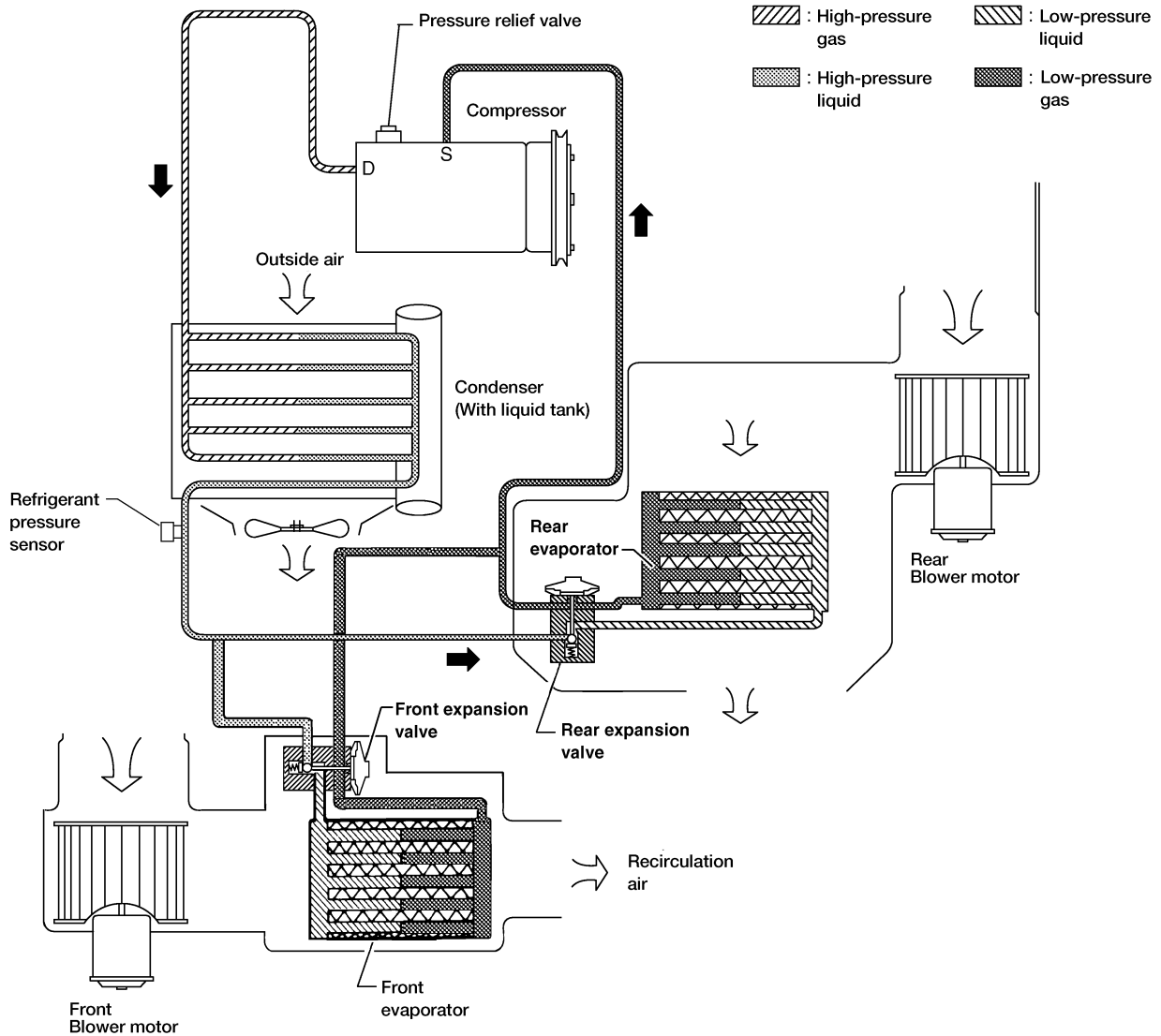

A
B
C
D
E
F
G
H
I
K
L
M

ATC

WJIA1342E

REFRIGERATION SYSTEM

Component Layout FRONT REFRIGERATION SYSTEM

EJS004JK

SEC. 270 273

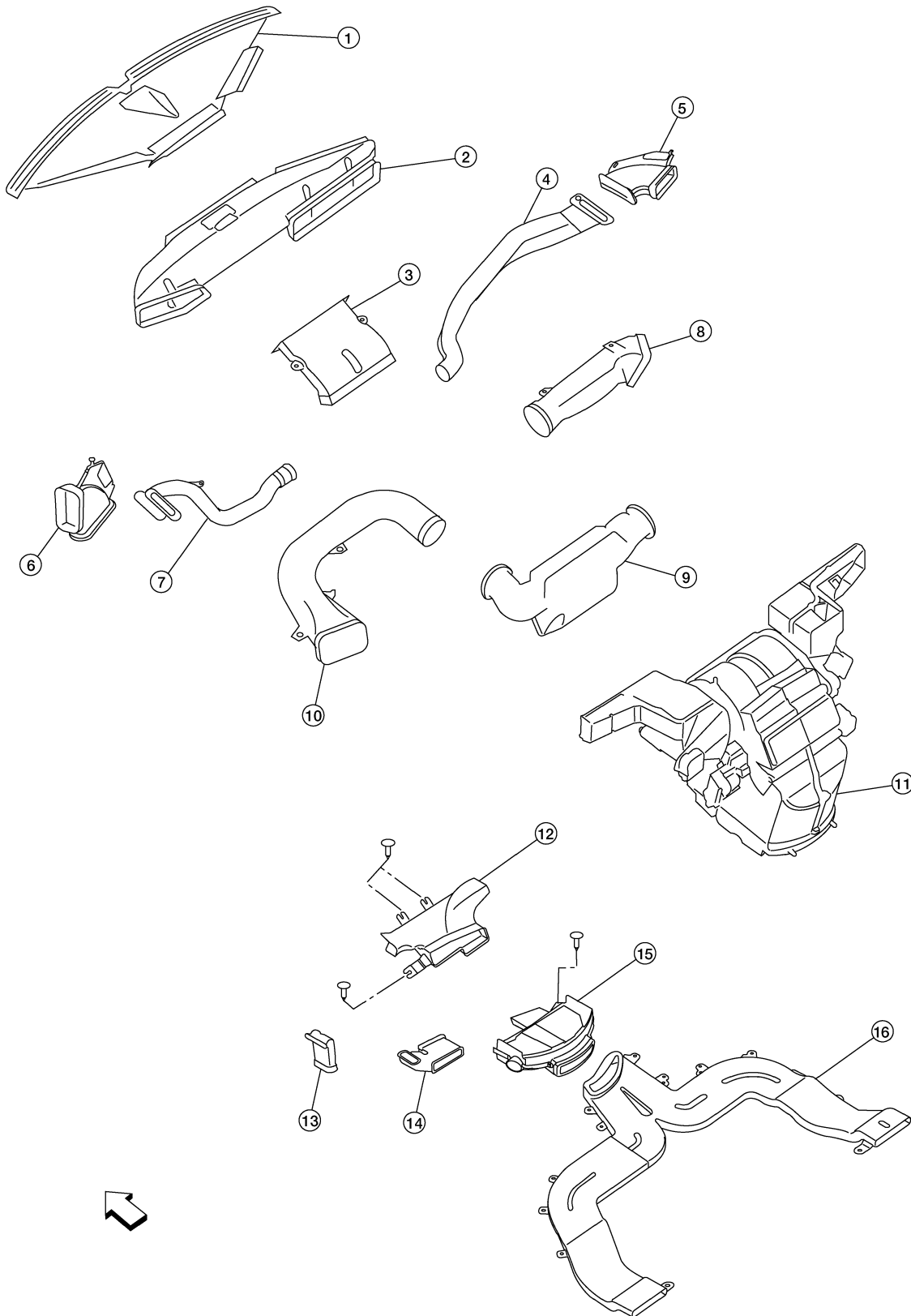

WJIA2219E

REFRIGERATION SYSTEM

- | | | |
|--|--|------------------------------------|
| 1. Defroster nozzle (part of the instrument panel) | 2. Fresh air duct | 3. Defroster duct |
| 4. RH side demister duct | 5. RH side demister duct extension | 6. LH side demister duct extension |
| 7. LH side demister duct | 8. RH ventilator duct | 9. Center ventilator duct |
| 10. LH ventilator duct | 11. Front heater and cooling unit assembly | 12. Floor connector duct |
| 13. Floor junction duct extension | 14. Floor junction duct | 15. Floor distribution duct |
| 16. Floor duct | | ← Front |

REAR REFRIGERATION SYSTEM

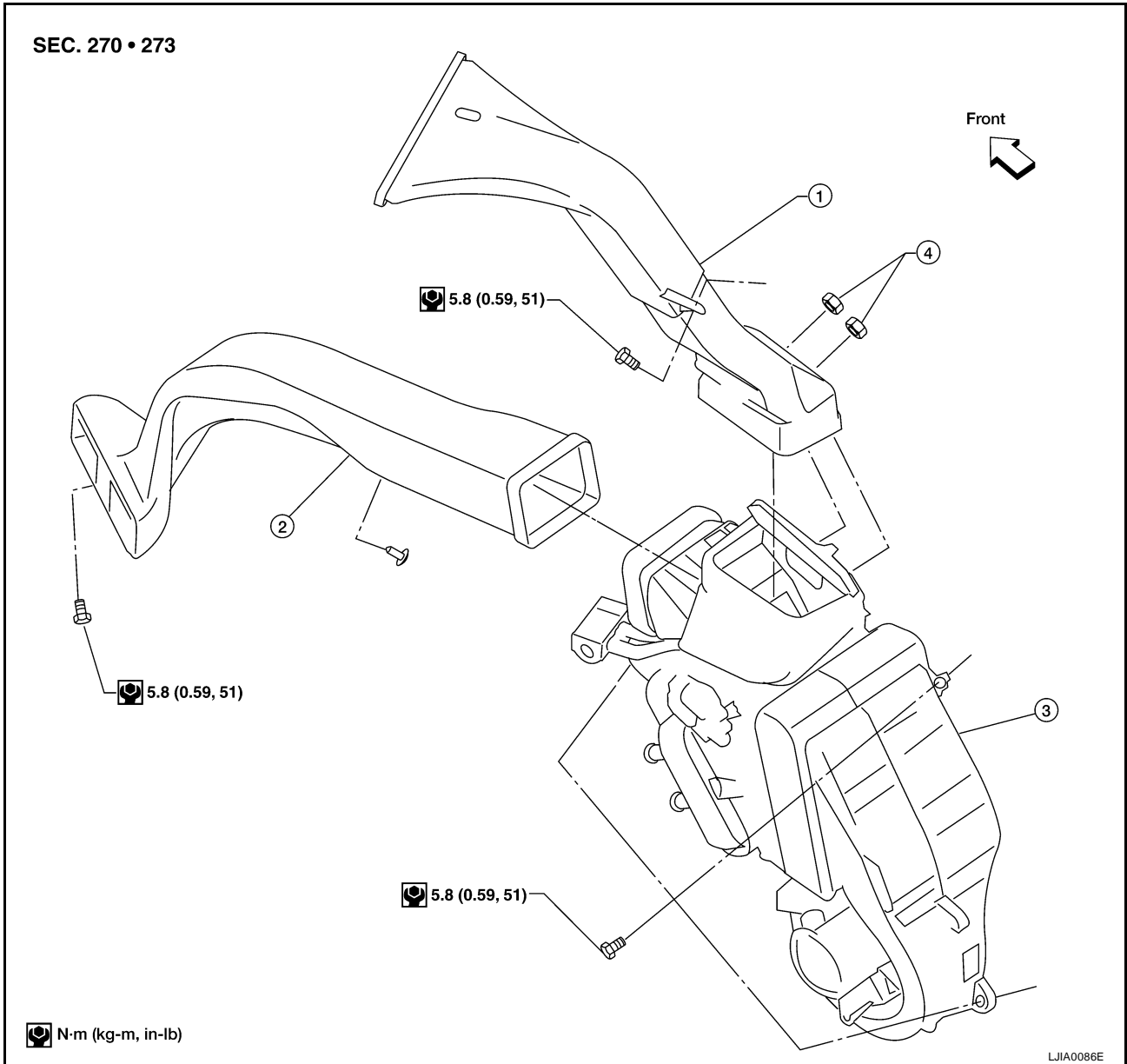

- | | | |
|-----------------------|-------------------|--|
| 1. Rear overhead duct | 2. Rear heat duct | 3. Rear heater and cooling unit assembly |
| 4. Clips | | |

A
B
C
D
E
F
G
H
I
ATC
K
L
M

OIL

PPF:KLG00

OIL

Maintenance of Oil Quantity in Compressor

EJS004JL

The oil in the compressor circulates through the system with the refrigerant. Add oil to compressor when replacing any component or after a large refrigerant leakage has occurred. It is important to maintain the specified amount.

If oil quantity is not maintained properly, the following malfunctions may result:

- Lack of oil: May lead to a seized compressor
- Excessive oil: Inadequate cooling (thermal exchange interference)

OIL

Name: NISSAN A/C System Oil Type S or equivalent

CHECKING AND ADJUSTING

CAUTION:

If excessive oil leakage is noted, do not perform the oil return operation.

Start the engine and set the following test conditions:

- Engine speed: Idling to 1,200 rpm
- A/C switch: On
- Blower fan speed: Maximum position
- Temperature control: Optional [set so that intake air temperature is 25° to 30° C (77° to 86°F).]
- Intake position: Recirculation ()
- Perform oil return operation for about ten minutes.

Adjust the oil quantity according to the following table.

Oil Adjusting Procedure for Components Replacement Except Compressor

After replacing any of the following major components, add the correct amount of oil to the system.

Amount of Oil to be Added

Part replaced	Oil to be added to system	Remarks
	Amount of oil m ℓ (US fl oz, Imp fl oz)	
Front evaporator	75 (2.5, 2.6)	—
Rear evaporator	75 (2.5, 2.6)	—
Condenser	75 (2.5, 2.6)	—
Liquid tank	5 (0.2, 0.2)	Add if compressor is not replaced.
In case of refrigerant leak	30 (1.0, 1.1)	Large leak
	—	Small leak *1

*1: If refrigerant leak is small, no addition of oil is needed.

OIL

Oil Adjustment Procedure for Compressor Replacement

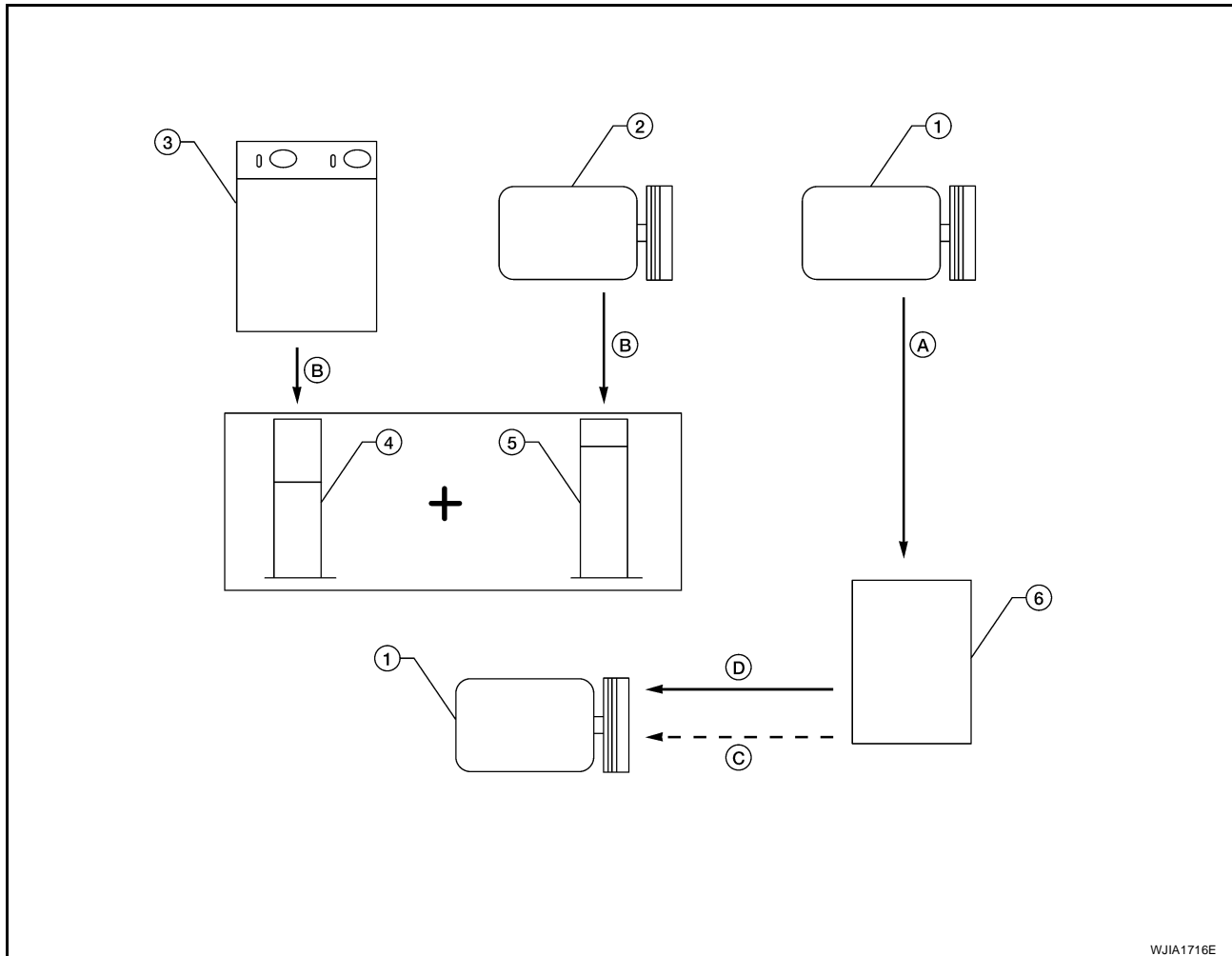

- | | | |
|---|-----------------------------------|---|
| 1. New compressor | 2. Old compressor | 3. Recovery/recycling equipment |
| 4. Measuring cup X | 5. Measuring cup Y | 6. New oil |
| A. Drain oil from the new compressor into clean container | B. Record amount of oil recovered | C. Add an additional 5 mℓ (0.2 US fl oz, 0.2 Imp fl oz) of new oil when replacing liquid tank |
| D. Install new oil equal to recorded amounts in measuring cups X plus Y | | |

- Before connecting recovery/recycling equipment to vehicle, check recovery/recycling equipment gauges. No refrigerant pressure should be displayed. If NG, recover refrigerant from equipment lines.
- Connect recovery/recycling equipment to vehicle. Confirm refrigerant purity in supply tank using recovery/recycling equipment and refrigerant identifier. If NG, refer to [ATC-5, "Contaminated Refrigerant"](#).
- Confirm refrigerant purity in vehicle A/C system using recovery/recycling equipment and refrigerant identifier. If NG, refer to [ATC-5, "Contaminated Refrigerant"](#).
- Discharge refrigerant into the refrigerant recovery/recycling equipment. Measure oil discharged into the recovery/recycling equipment.
- Drain the oil from the "old" (removed) compressor into a graduated container and recover the amount of oil drained.
- Drain the oil from the "new" compressor into a separate, clean container.
- Measure an amount of new oil installed equal to amount drained from "old" compressor. Add this oil to "new" compressor through the suction port opening.
- Measure an amount of new oil equal to the amount recovered during discharging. Add this oil to "new" compressor through the suction port opening.
- If the liquid tank also needs to be replaced, add an additional 5 mℓ (0.2 US fl oz, 0.2 Imp fl oz) of oil at this time.

OIL

CAUTION:

Do not add this 5 mℓ (0.2 US fl oz, 0.2 Imp fl oz) of oil if only replacing the compressor.

AIR CONDITIONER CONTROL

AIR CONDITIONER CONTROL

PFP:27500

Description

EJS004JM

The front air control provides automatic regulation of the vehicle's interior temperature. The system is based on the driver's and passenger's selected "set temperature", regardless of the outside temperature changes. This is done by utilizing a microcomputer, also referred to as the front air control, which receives input signals from the following six sensors:

- Ambient sensor
- In-vehicle sensor
- Intake sensor
- Optical sensor (providing one input for driver and one input for passenger side)
- PBR (position balanced resistor).
- Engine coolant temperature sensor (via CAN communication)
- Vehicle speed signal (via CAN communication)

The front air control uses these signals (including the set temperature) to automatically control:

- Outlet air volume
- Air temperature
- Air distribution

The front air control also provides separate regulation of the vehicle's interior temperature for the rear passenger area. The system is based on the rear temperature and blower settings selected from rear air control (front) control dials located in the overhead console, or from the rear temperature and blower settings from the rear air control (rear) control dials, when the REAR CTRL switch is pressed (indicator light is on) on the rear air control (front).

The front air control is used to select:

- Outlet air volume
- Air temperature/distribution

Operation

EJS004JN

AIR MIX DOORS CONTROL (AUTOMATIC TEMPERATURE CONTROL)

The air mix doors are automatically controlled so that in-vehicle temperature is maintained at a predetermined value by: The temperature setting, ambient temperature, in-vehicle temperature and amount of sunload.

BLOWER SPEED CONTROL

Blower speed is automatically controlled based on temperature setting, ambient temperature, in-vehicle temperature, intake temperature, amount of sunload and air mix door position.

When AUTO switch is pressed, the blower motor starts to gradually increase air flow volume (if required).

When engine coolant temperature is low, the blower motor operation is delayed to prevent cool air from flowing.

INTAKE DOORS CONTROL

The intake doors are automatically controlled by: The temperature setting, ambient temperature, in-vehicle temperature, intake temperature, amount of sunload and ON-OFF operation of the compressor. Recirculation is not allowed in floor, floor/defrost or defrost modes.

MODE DOOR CONTROL

The mode door is automatically controlled by: The temperature setting, ambient temperature, in-vehicle temperature, intake temperature and amount of sunload.

DEFROSTER DOOR CONTROL

The defroster door is controlled by: Turning the defroster dial to front defroster.

A
B
C
D
E
F
G
H
I
K
L
M

ATC

AIR CONDITIONER CONTROL

MAGNET CLUTCH CONTROL

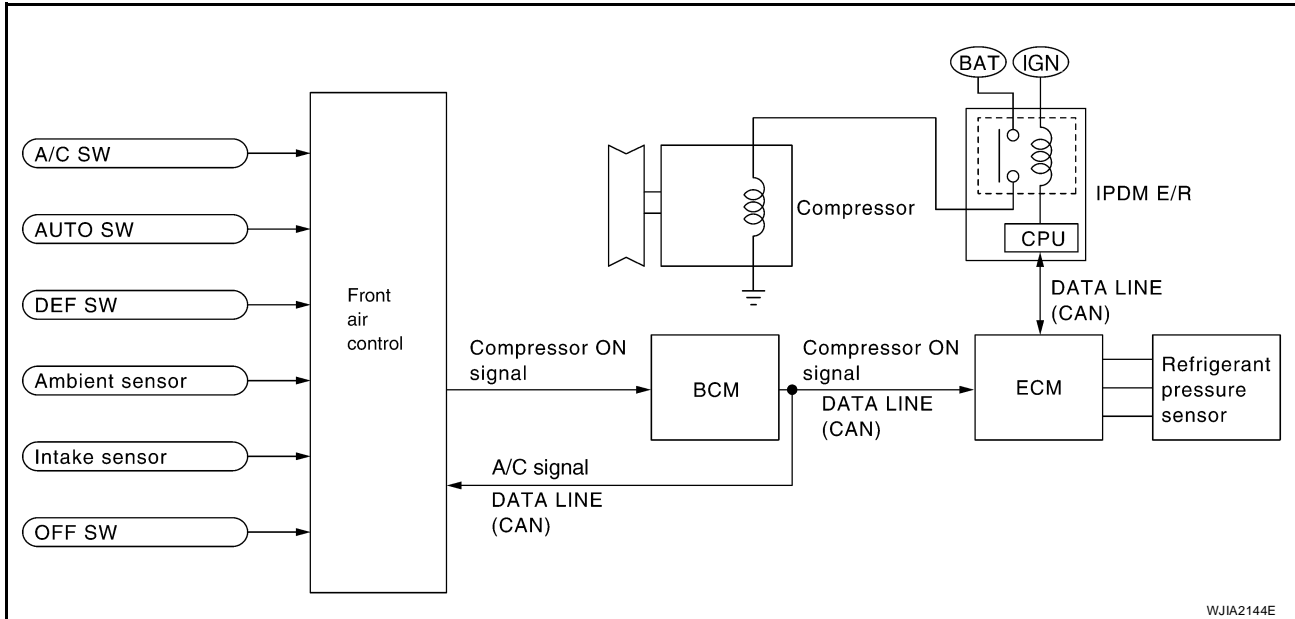

WJIA2144E

When A/C switch or DEF switch is pressed, front air control outputs compressor ON signal to BCM. BCM sends compressor ON signal to ECM and front air control, via CAN communication line. ECM judges whether compressor can be turned ON, based on each sensor status (refrigerant pressure sensor signal, throttle angle sensor, etc.). If it judges compressor can be turned ON, it sends compressor ON signal to IPDM E/R, via CAN communication line. Upon receipt of compressor ON signal from ECM, IPDM E/R turns air conditioner relay ON to operate compressor.

SELF-DIAGNOSTIC SYSTEM

The self-diagnostic system is built into the front air control to quickly locate the cause of certain symptoms. Refer to [ATC-53, "A/C System Self-diagnosis Function"](#) .

AIR CONDITIONER CONTROL

EJS004JO

Description of Control System

The control system consists of input sensors, switches, the front air control (microcomputer) and outputs. The relationship of these components is shown in the figure below:

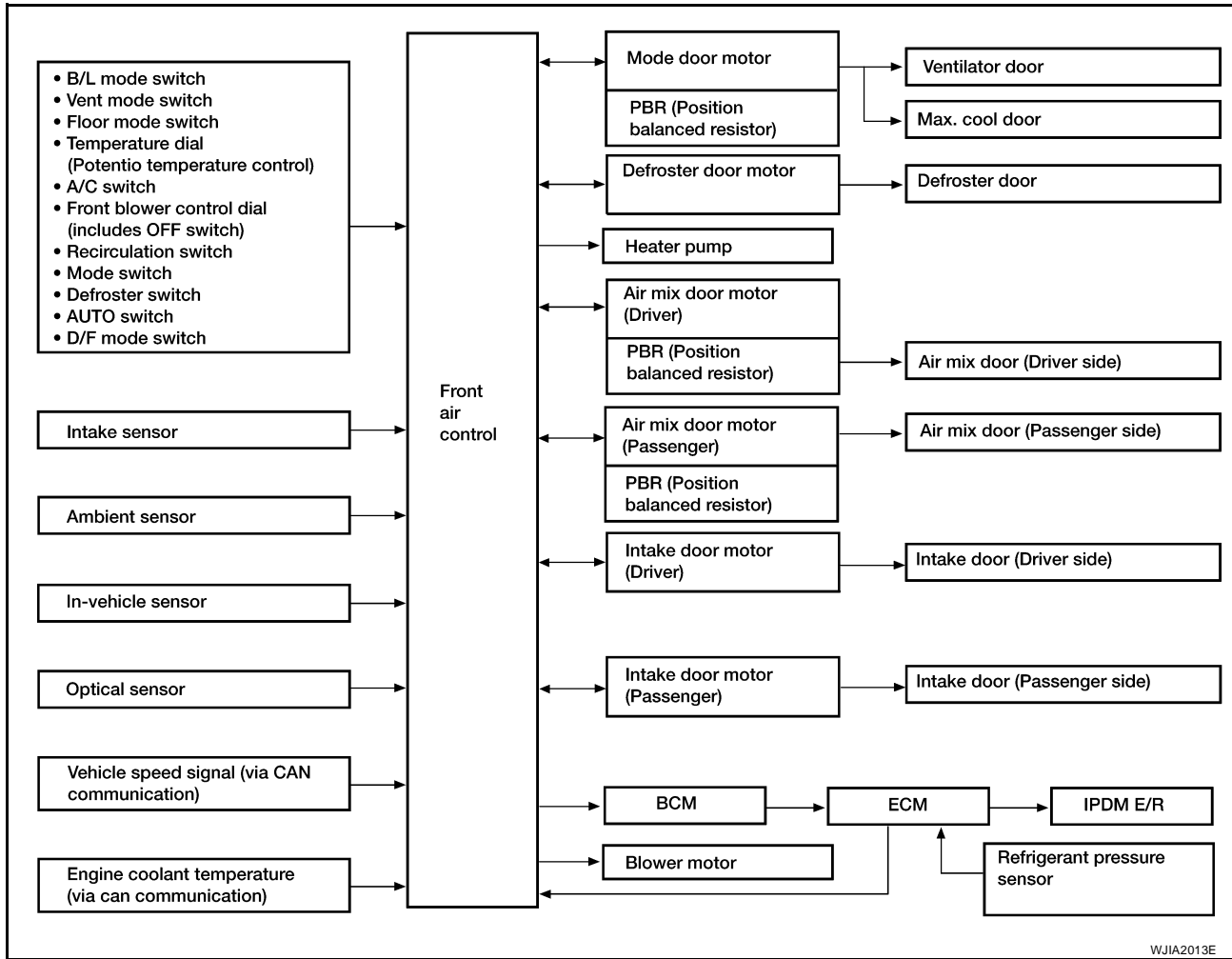

WJIA2013E

Control Operation

EJS004JP

Front air control

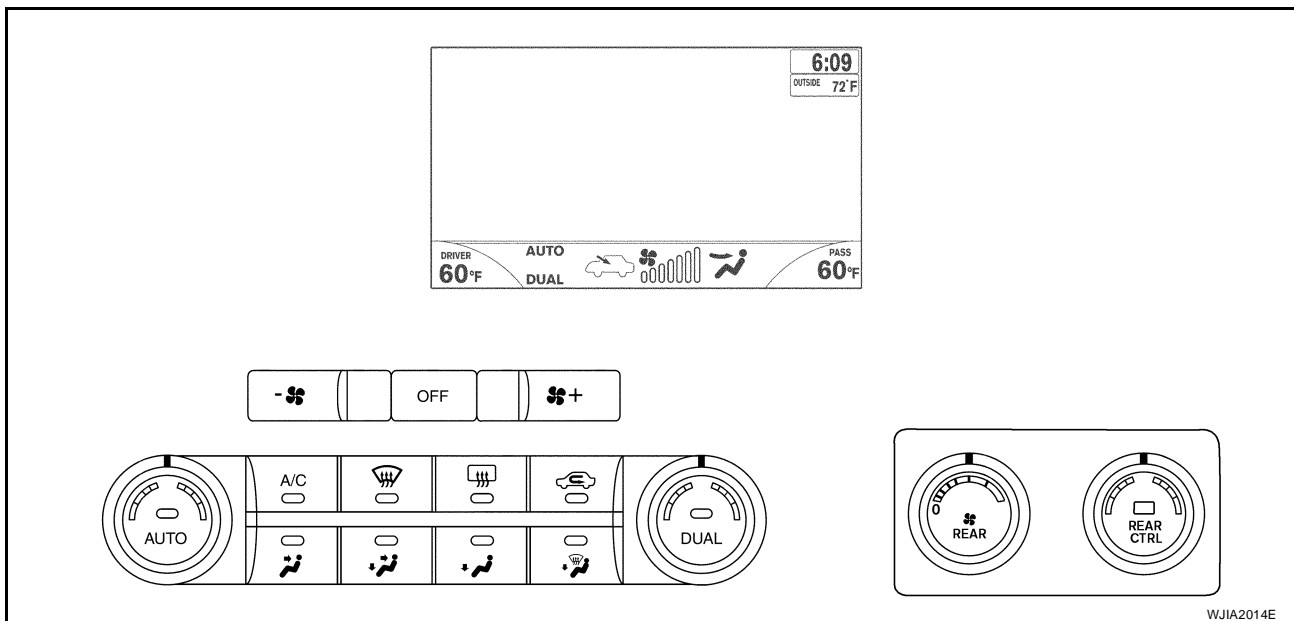

WJIA2014E

AIR CONDITIONER CONTROL

Rear air control

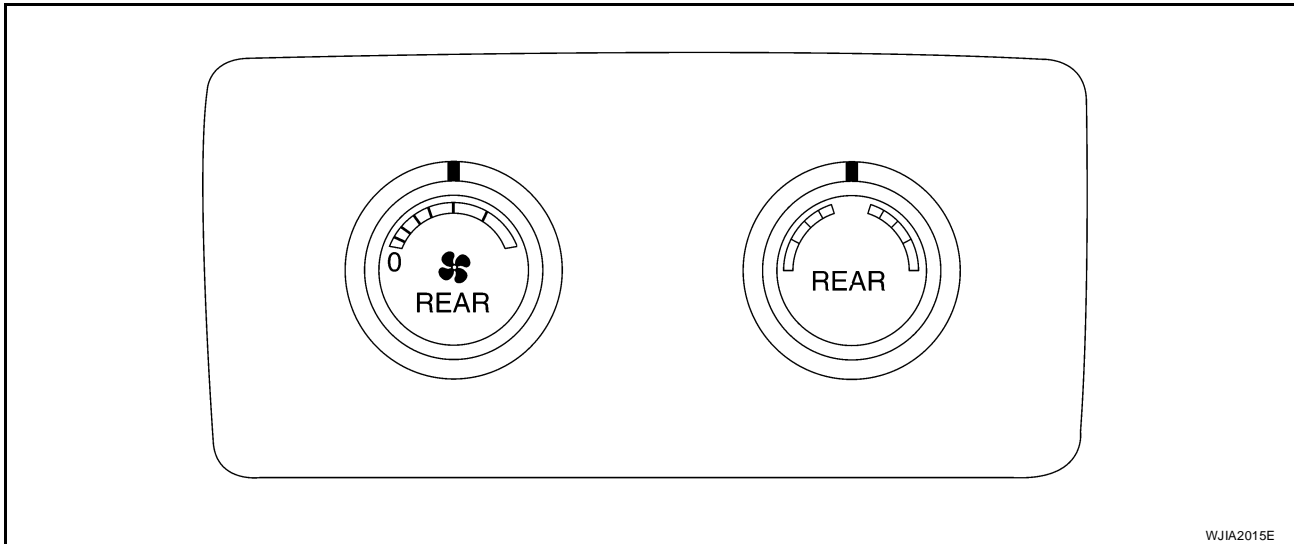

DISPLAY SCREEN

Displays the operational status of the system.

AUTO SWITCH

- The compressor, intake doors, air mix doors, outlet doors and blower speed are automatically controlled so that the in-vehicle temperature will reach, and be maintained at the set temperature selected by the operator.
- When pressing AUTO switch, air inlet, air outlet, blower speed, and discharge air temperature are automatically controlled.

TEMPERATURE CONTROL DIAL (DRIVER SIDE)

Increases or decreases the set temperature.

TEMPERATURE CONTROL DIAL (PASSENGER SIDE)

Increases or decreases the set temperature.

REAR TEMPERATURE/MODE CONTROL DIAL (FRONT)

Increases or decreases the set temperature and changes the location of the rear discharged air.

REAR TEMPERATURE/MODE CONTROL DIAL (REAR)

Increases or decreases the set temperature and changes the location of the rear discharged air.

RECIRCULATION () SWITCH

- When REC switch is ON, REC switch indicator turns ON, and air inlet is set to REC.
- When REC switch is turned OFF, or when compressor is turned from ON to OFF, REC switch is automatically turned OFF. REC mode can be re-entered by pressing REC switch again.
- REC switch is not operated when DEF switch is turned ON the D/F position, or in floor mode.

DEFROSTER () SWITCH

Positions the air outlet doors to the defrost position. Also positions the intake doors to the outside air position. The compressor remains ON until the ignition is turned OFF.

REAR WINDOW DEFOGGER SWITCH

When switch is ON, rear window is defogged.

OFF SWITCH

The compressor and blower are OFF, the intake doors are set to the outside air position, and the air outlet doors are set to the foot (75% foot and 25% defrost) position.

A/C SWITCH

The compressor is ON or OFF.

(Pressing the A/C switch when the AUTO switch is ON will turn off the A/C switch and compressor.)

AIR CONDITIONER CONTROL

MODE SWITCHES

Controls the air discharge outlets.

FRONT BLOWER CONTROL DIAL

Manually control the blower speed. Seven speeds are available for manual control (as shown on the display screen).

REAR BLOWER CONTROL DIAL (FRONT)

When the REAR CTRL switch is off (indicator off) the rear air control (front) controls the rear blower motor speed regardless of the rear air control (rear) blower control dial (rear) position. The rear air control (front) controls the blower motor speed and the temperature/mode settings.

REAR BLOWER CONTROL DIAL (REAR)

When the REAR CTRL switch is on (indicator on) the rear air control (rear) controls the rear blower motor speed regardless of the rear air control (front) blower control dial (front) position. The rear air control (rear) controls the blower motor speed and the temperature/mode settings.

Discharge Air Flow FRONT

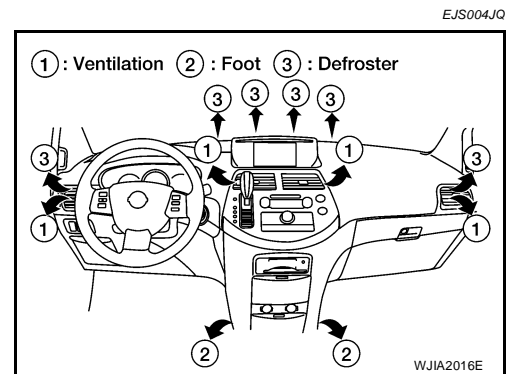

REAR

NOTE:

Hot air comes from the floor vents, cold air comes from the roof vents, and blend air comes from both vents.

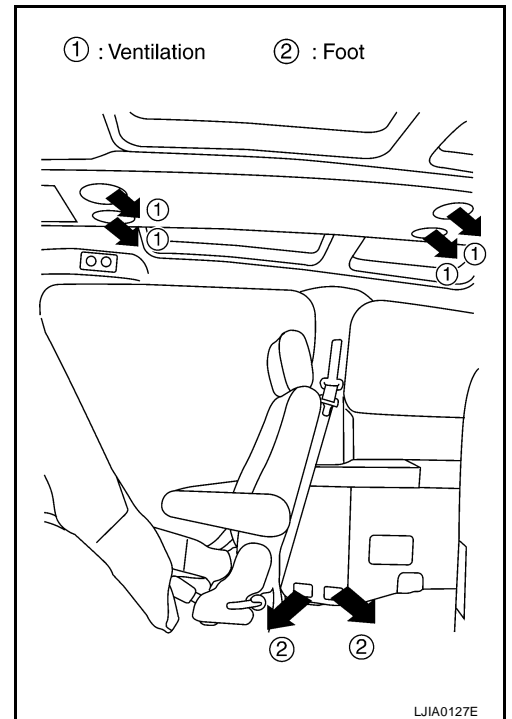

A
B
C
D
E
F
G
H
I

ATC

K
L
M

AIR CONDITIONER CONTROL

EJS004JR

System Description SWITCHES AND THEIR CONTROL FUNCTION

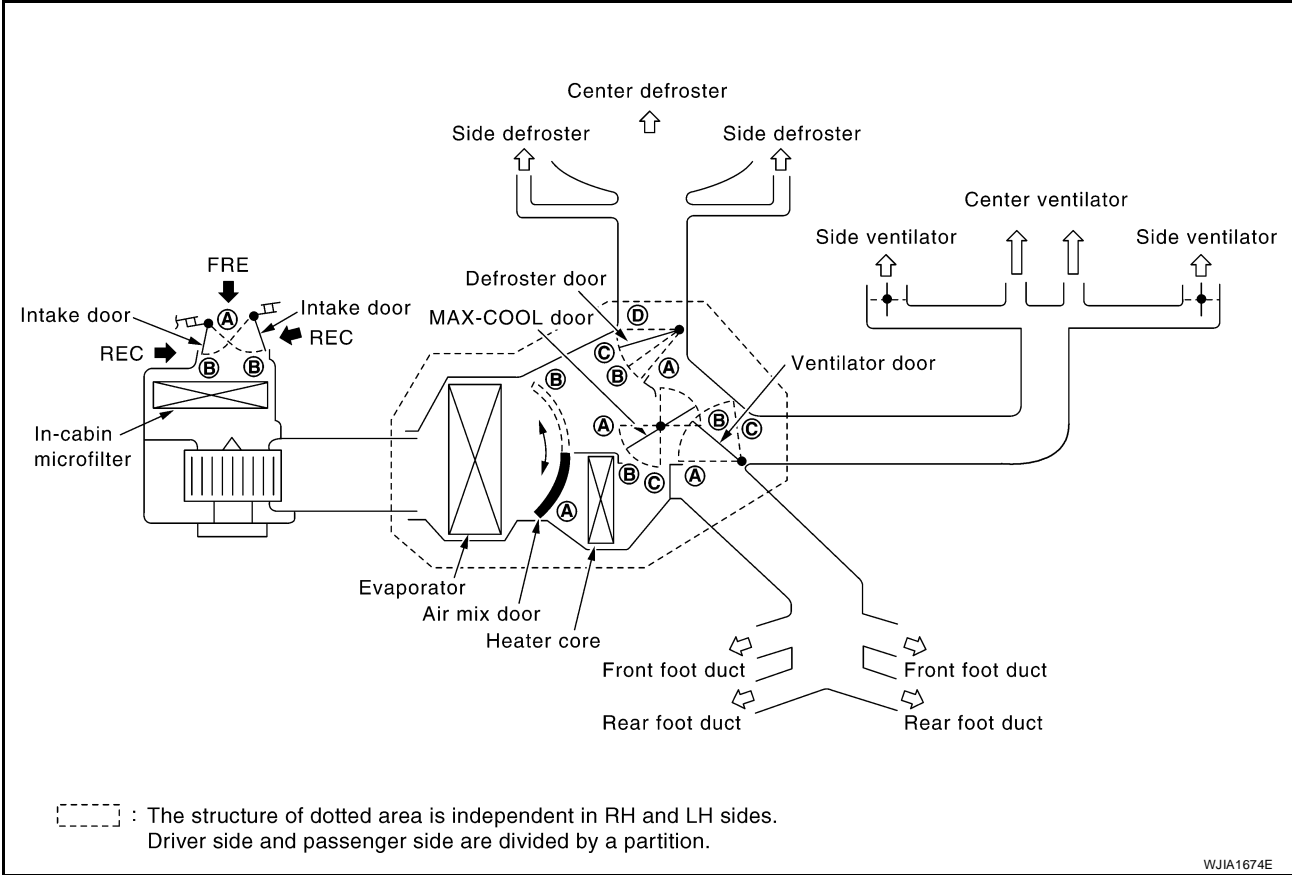

Position or switch	MODE SW				DEF SW		AUTO SW	REC SW		Temperature dial			OFF SW
	VENT	B/L	FOOT	D/F	ON	OFF		ON	OFF				
Door							AUTO						OFF
Ventilator door	(A)	(B)	(C)	(C)	(C)		AUTO	—	—	—			(C)
MAX-COOL door	(A)	(B)	(B)	(B)	(C)			—	—	—			(B)
Defroster door	(D)	(D)	(D) or (C) ^{*1}	(B)	(A)	—	—	—	—	—			(C)
Intake door	—				(B)		—	(A) ^{*2}	(B) ^{*2}	—			(B)
Air mix door	—				—		AUTO	—		(A)	AUTO	(B)	—

*1: This position is selected only when the mode door is automatically controlled.
*2: Inlet status is displayed even during automatic control.

WJIA2017E

AIR CONDITIONER CONTROL

CAN Communication System Description

EJS004JS

Refer to [LAN-4, "SYSTEM DESCRIPTION"](#) .

A

B

C

D

E

F

G

H

I

ATC

K

L

M

TROUBLE DIAGNOSIS

TROUBLE DIAGNOSIS

PFP:00004

CONSULT-II Function (HVAC)

EJS00405

CONSULT-II can display each diagnostic item using the diagnostic test modes shown following.

Diagnostic mode	Description
SELF-DIAG RESULTS	Displays front air control self-diagnosis results.
DATA MONITOR	Displays front air control input/output data in real time.
CAN DIAG SUPPORT MNTR	The result of transmit/receive diagnosis of CAN communication can be read.
ECU PART NUMBER	Front air control part number can be read.

CONSULT-II START PROCEDURE

Refer to [GI-37, "CONSULT-II Start Procedure"](#) .

SELF-DIAGNOSIS

Operation Procedure

1. Touch "SELF-DIAG RESULTS" on "SELECT DIAG MODE" screen to view all set DTC's.

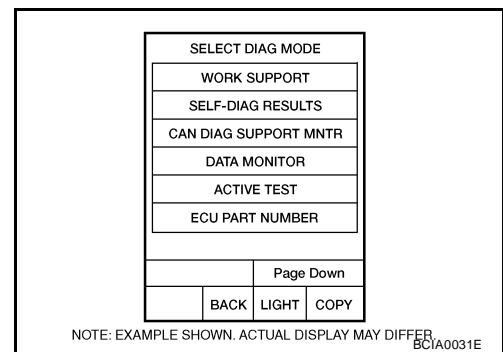

Display Item List

DTC	Reference page	
B2572	EE changed by calibration	ATC-160, "FRONT AIR CONTROL"
B2573	Battery voltage out of range	SC-4, "BATTERY"
B2574	Air mix door motor (passenger) circuit failure	ATC-77, "DIAGNOSTIC PROCEDURE FOR AIR MIX DOOR MOTOR (PASSENGER)"
B2575	BCM not responding to A/C request	ATC-124, "Magnet Clutch Circuit"
B2576	BCM not responding to rear defroster request	GW-87, "REAR WINDOW DEFOGGER"
B2577	Air mix door motor (driver) circuit failure	ATC-73, "DIAGNOSTIC PROCEDURE FOR AIR MIX DOOR MOTOR (DRIVER)"
B2578	In-vehicle sensor circuit out of range (low)	ATC-151, "In-vehicle Sensor Circuit"
B2579	In-vehicle sensor circuit out of range (high)	
B257A	Air mix door motor (rear) circuit failure	ATC-81, "DIAGNOSTIC PROCEDURE FOR AIR MIX DOOR MOTOR (REAR)"
B257B	Ambient sensor circuit open	ATC-148, "Ambient Sensor Circuit"
B257C	Ambient sensor circuit short	
B257D	In-vehicle sensor motor circuit open	ATC-151, "In-vehicle Sensor Circuit"
B257E	In-vehicle sensor motor circuit short	
B257F	Optical sensor (driver) circuit open or short	ATC-155, "Optical Sensor Circuit"
B2580	Optical sensor (passenger) circuit open or short	
B2581	Intake sensor circuit short	ATC-158, "Intake Sensor Circuit"
B2582	Intake sensor circuit open	
B2583	Defroster door motor circuit failure	ATC-92, "Defroster Door Motor Circuit"

TROUBLE DIAGNOSIS

DTC	Reference page	
B2584	Intake door motor (passenger) circuit failure	ATC-90, "DIAGNOSTIC PROCEDURE FOR INTAKE DOOR MOTOR (PASSENGER)"
U1000	CAN bus fault	LAN-7, "TROUBLE DIAGNOSIS"
B2586	Intake door motor (driver) circuit failure	ATC-88, "DIAGNOSTIC PROCEDURE FOR INTAKE DOOR MOTOR (DRIVER)"
B2587	Stuck button	ATC-160, "FRONT AIR CONTROL"
B2587	Mode door motor circuit failure	ATC-62, "Mode Door Motor Circuit"

DATA MONITOR

Operation Procedure

1. Touch "DATA MONITOR" on "SELECT DIAG MODE" screen.

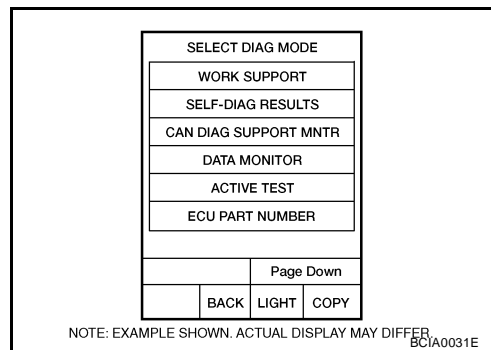

2. Touch either "MAIN SIGNALS" or "SELECTION FROM MENU" on "DATA MONITOR" screen.

MAIN SIGNALS	Monitors all the items.
SELECTION FROM MENU	Selects and monitors the individual item selected.

3. When "SELECTION FROM MENU" is selected, touch items to be monitored. When "MAIN SIGNALS" is selected, all the items will be monitored.
4. Touch "START".
5. Touch "RECORD" while monitoring, then the status of the monitored item can be recorded. To stop recording, touch "STOP".

Display Item List

Monitor item	Value	Contents
BATT VIA CAN	"V"	Displays battery voltage signal.
IGN VIA CAN	"ON/OFF"	Displays ignition switch signal.
DVR SUNLD SEN	"W/M2"	Displays optical sensor (driver) signal.
PAS SUNLD SEN	"W/M2"	Displays optical sensor (passenger) signal.
AMB TEMP SEN	"°C/°F"	Displays ambient temperature sensor signal.
EVAP TEMP SEN	"°C/°F"	Displays intake sensor signal.
INCAR TMP SEN	"°C/°F"	Displays in-vehicle temperature sensor signal.
RR TEMPSET FR	"V"	Displays air mix door (front) set point signal.
RR TEMPSET RR	"V"	Displays air mix door (rear) set point signal.
MODE FDBCK	"V"	Displays mode door motor feedback signal.
DVR MIX FDBCK	"V"	Displays intake door motor (driver) feedback signal.
PAS MIX FDBCK	"V"	Displays intake door motor (passenger) feedback signal.
RR FDBCK	"V"	Displays air mix door motor (rear) feedback signal.
RECIRC	"ON/OFF"	Displays recirculation switch signal.
DEFROST	"V"	Displays defroster switch signal.

TROUBLE DIAGNOSIS

Monitor item	Value	Contents
AUTO	"ON/OFF"	Displays AUTO switch signal.
A/C	"ON/OFF"	Displays A/C switch signal.
MODE	"ON/OFF"	Displays MODE dial signal.
L TEMP UP	"ON/OFF"	Displays driver side temperature control dial (temp increase) signal.
L TEMP DOWN	"ON/OFF"	Displays driver side temperature control dial (temp decrease) signal.
R TEMP UP	"ON/OFF"	Displays rear temperature control dial [front (temp increase)] signal.
R TEMP DOWN	"ON/OFF"	Displays rear temperature control dial [front (temp decrease)] signal.
RR DEFOG	"ON/OFF"	Displays rear defroster request signal.
FAN UP	"ON/OFF"	Displays front blower motor (blower speed increase) signal.
FAN DOWN	"ON/OFF"	Displays front blower motor (blower speed decrease) signal.
MODE SELECT	" [PNL]" " [MIX]" " [FLR]" " [DEFR]" " [MAX]" " [DENT]**	Displays mode door motor position.

*: DENT is displayed when MODE dial is between selections.

TROUBLE DIAGNOSIS

CONSULT-II Function (BCM)

EJS004JT

CONSULT-II can display each diagnostic item using the diagnostic test modes shown following.

BCM diagnostic test item	Diagnostic mode	Description
Inspection by part	WORK SUPPORT	Supports inspections and adjustments. Commands are transmitted to the BCM for setting the status suitable for required operation, input/output signals are received from the BCM and received data is displayed.
	DATA MONITOR	Displays BCM input/output data in real time.
	ACTIVE TEST	Operation of electrical loads can be checked by sending drive signal to them.
	SELF-DIAG RESULTS	Displays BCM self-diagnosis results.
	CAN DIAG SUPPORT MNTR	The result of transmit/receive diagnosis of CAN communication can be read.
	ECU PART NUMBER	BCM part number can be read.
	CONFIGURATION	Performs BCM configuration read/write functions.

CONSULT-II START PROCEDURE

Refer to [GI-37, "CONSULT-II Start Procedure"](#).

DATA MONITOR

Operation Procedure

1. Touch "AIR CONDITIONER" on "SELECT TEST ITEM" screen.

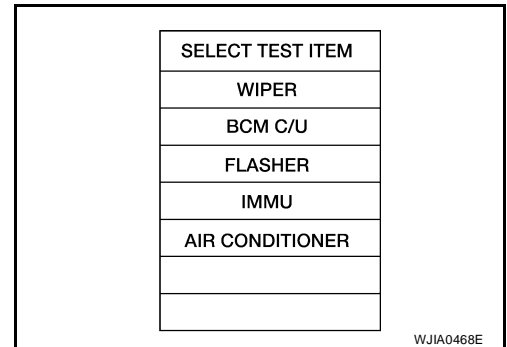

2. Touch "DATA MONITOR" on "SELECT DIAG MODE" screen.

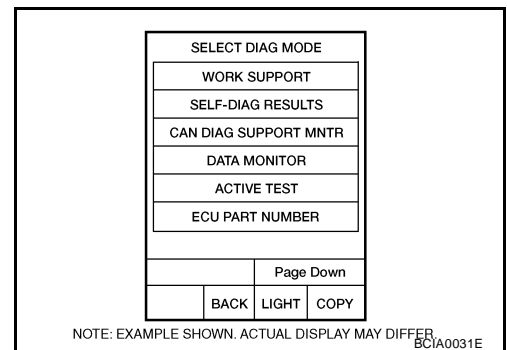

3. Touch either "ALL SIGNALS" or "SELECTION FROM MENU" on "DATA MONITOR" screen.

ALL SIGNALS	Monitors all the items.
SELECTION FROM MENU	Selects and monitors the individual item selected.

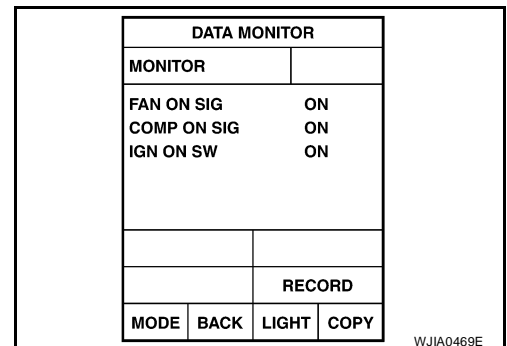

4. Touch "START".
5. When "SELECTION FROM MENU" is selected, touch items to be monitored. When "ALL SIGNALS" is selected, all the items will be monitored.
6. Touch "RECORD" while monitoring, then the status of the monitored item can be recorded. To stop recording, touch "STOP".

TROUBLE DIAGNOSIS

Display Item List

Monitor item name "operation or unit"	Contents
IGN ON SW "ON/OFF"	Displays "IGN Position (ON)/OFF, ACC Position (OFF)" status as judged from ignition switch signal.
COMP ON SIG "ON/OFF"	Displays "COMP (ON)/COMP (OFF)" status as judged from air conditioner switch signal.
FAN ON SIG "ON/OFF"	Displays "FAN (ON)/FAN (OFF)" status as judged from blower fan motor switch signal.

How to Perform Trouble Diagnosis for Quick and Accurate Repair WORK FLOW

EJS004JU

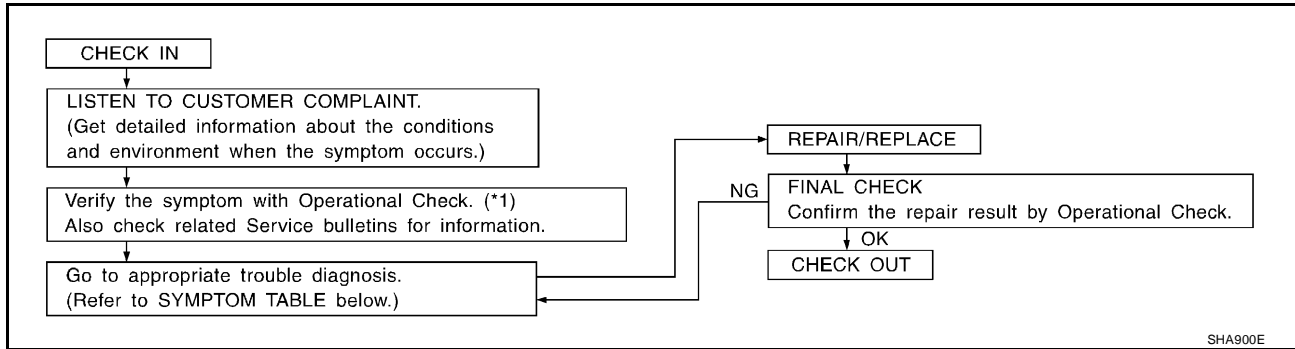

*1 [ATC-55, "Operational Check \(Front\)"](#)

SYMPTOM TABLE

Symptom	Reference Page
A/C system does not come on.	Go to Trouble Diagnosis Procedure for A/C System. ATC-59, "Power Supply and Ground Circuit for Front Air Control"
A/C system display is malfunctioning.	Go to Navigation System, or Integrated Display System. AV-170, "NAVIGATION SYSTEM" (With NAVI.) or AV-109, "INTEGRATED DISPLAY SYSTEM" (Without NAVI)
A/C system cannot be controlled.	Go to Self-diagnosis Function. ATC-53, "A/C System Self-diagnosis Function"
Air outlet does not change.	Go to Trouble Diagnosis Procedure for Mode Door Motor. ATC-62, "Mode Door Motor Circuit"
Mode door motor is malfunctioning.	
Discharge air temperature does not change.	Go to Trouble Diagnosis Procedure for Air Mix Door Motor. ATC-70, "Air Mix Door Motor Circuit"
Air mix door motor is malfunctioning.	
Intake door does not change.	Go to Trouble Diagnosis Procedure for Intake Door Motor. ATC-86, "Intake Door Motor Circuit"
Intake door motor is malfunctioning.	
Defroster door motor is malfunctioning.	Go to Trouble Diagnosis Procedure for Defroster Door Motor. ATC-92, "Defroster Door Motor Circuit"
Front blower motor operation is malfunctioning.	Go to Trouble Diagnosis Procedure for Front Blower Motor. ATC-96, "Front Blower Motor Circuit"
Rear blower motor operation is malfunctioning.	Go to Trouble Diagnosis Procedure for Rear Blower Motor. ATC-105, "Rear Blower Motor Circuit"

TROUBLE DIAGNOSIS

Symptom	Reference Page	
Rear discharge air temperature and/or air outlet does not change.	Go to Trouble Diagnosis Procedure for Rear Air Control circuit.	ATC-118, "Rear Air Temperature Control Circuit"
Magnet clutch does not engage.	Go to Trouble Diagnosis Procedure for Magnet Clutch.	ATC-124, "Magnet Clutch Circuit"
Insufficient cooling	Go to Trouble Diagnosis Procedure for Insufficient Cooling.	ATC-130, "Insufficient Cooling"
Insufficient heating	Go to Trouble Diagnosis Procedure for Insufficient Heating.	ATC-138, "Insufficient Heating"
Noise	Go to Trouble Diagnosis Procedure for Noise.	ATC-143, "Noise"
Self-diagnosis cannot be performed.	Go to Trouble Diagnosis Procedure for Self-diagnosis.	ATC-145, "Self-diagnosis"
Memory function does not operate.	Go to Trouble Diagnosis Procedure for Memory Function.	ATC-147, "Memory Function"

A
B
C
D
E
F
G
H
I
K
L
M

ATC

TROUBLE DIAGNOSIS

Component Parts and Harness Connector Location ENGINE COMPARTMENT

EJS004JV

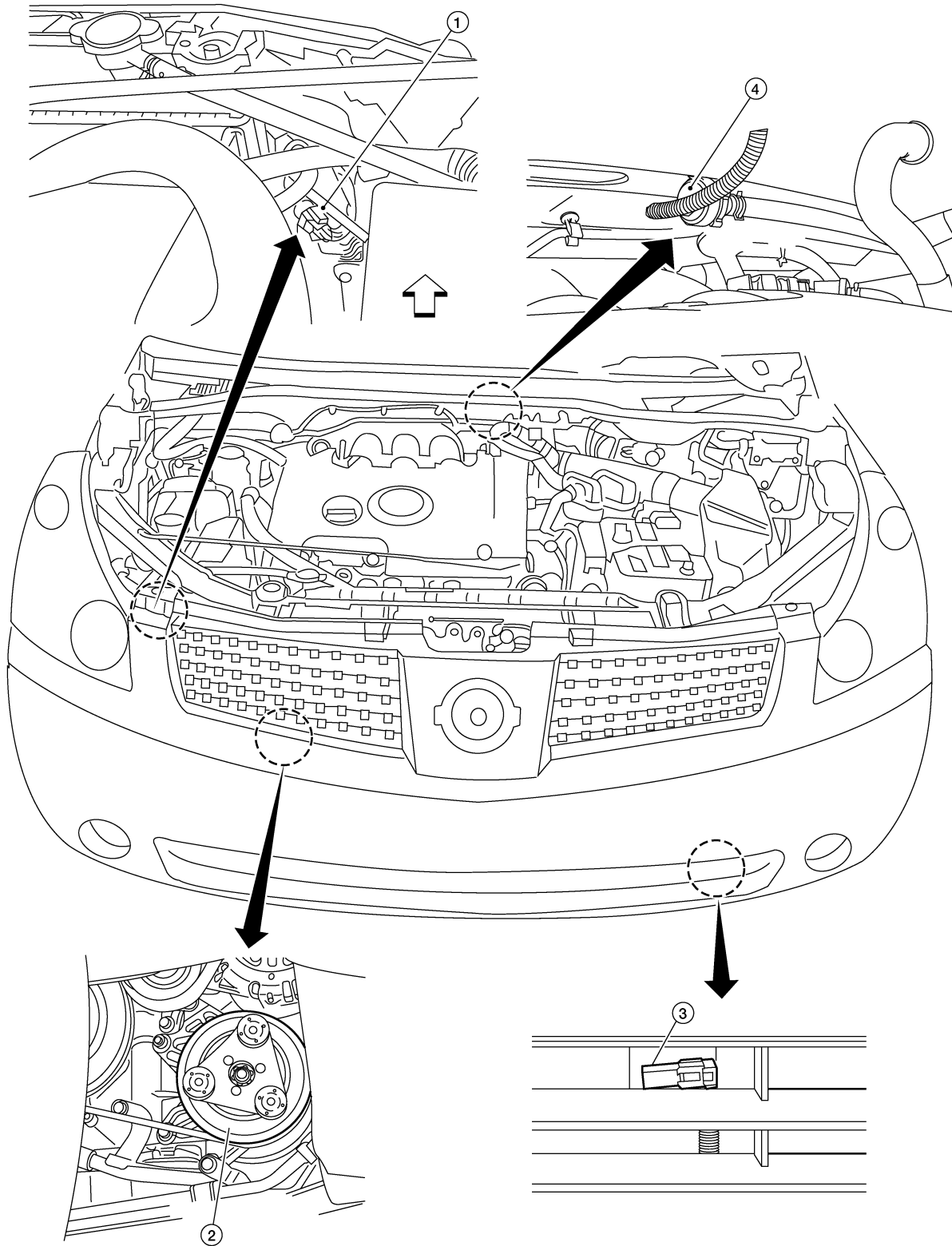

1. Refrigerant pressure sensor E111
2. Compressor F3 (view from right tire)
3. Ambient Sensor E1 housing
4. Heater pump E127

WJIA2221E

TROUBLE DIAGNOSIS

FRONT PASSENGER COMPARTMENT

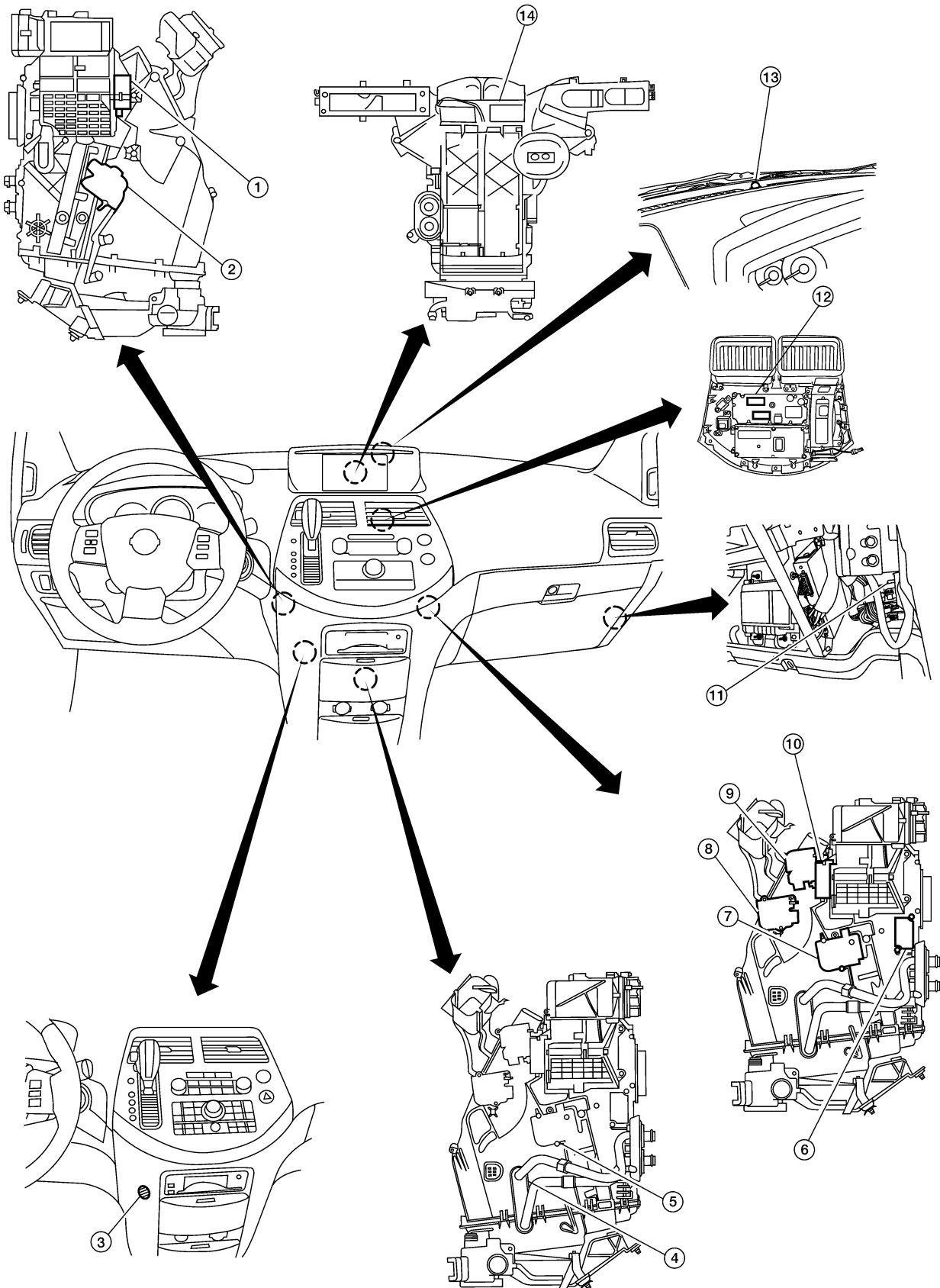

A
B
C
D
E
F
G
H
I
K
L
M

ATC

- 1. Intake door motor (driver) M58
- 4. Evaporator

- 2. Air mix door motor (driver) M39
- 5. Intake sensor M305

- 3. In-vehicle sensor M32
- 6. Variable blower control (front) M122

WJIA2018E

TROUBLE DIAGNOSIS

- | | | |
|--|----------------------------|--------------------------------|
| 7. Air mix door motor (passenger) M306 | 8. Mode door motor M304 | 9. Defroster door motor M303 |
| 10. Intake door motor (passenger) M302 | 11. Heater pump relay E128 | 12. Front air control M49, M50 |
| 13. Optical sensor M16 | 14. Front blower motor M62 | |

TROUBLE DIAGNOSIS

REAR PASSENGER COMPARTMENT

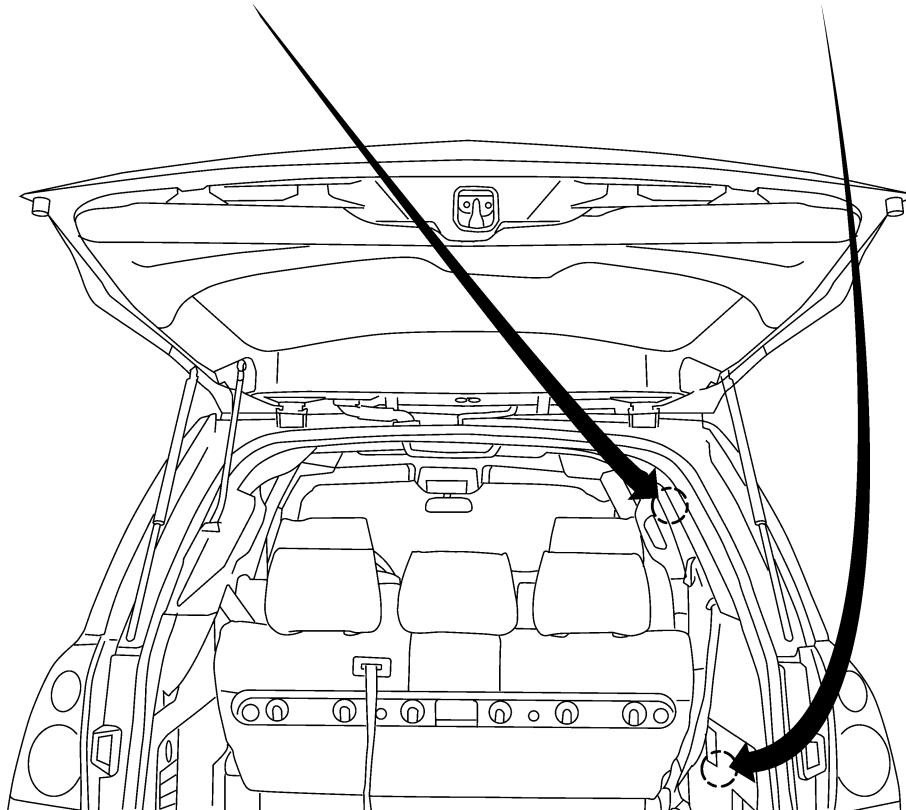
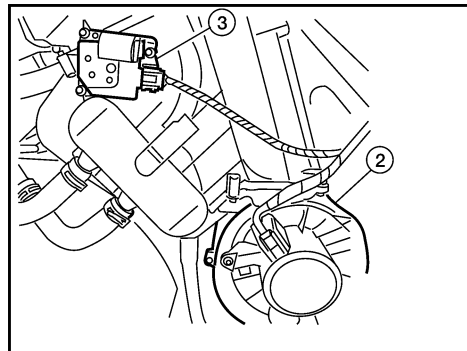
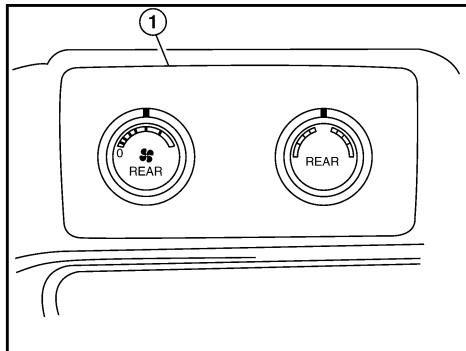

A

B

C

D

E

F

G

H

I

ATC

K

L

M

1. Rear air control (rear) B150

2. Rear blower motor B134

3. Air mix door motor (rear) B146

WJIA2019E

TROUBLE DIAGNOSIS

EJS004JW

Schematic

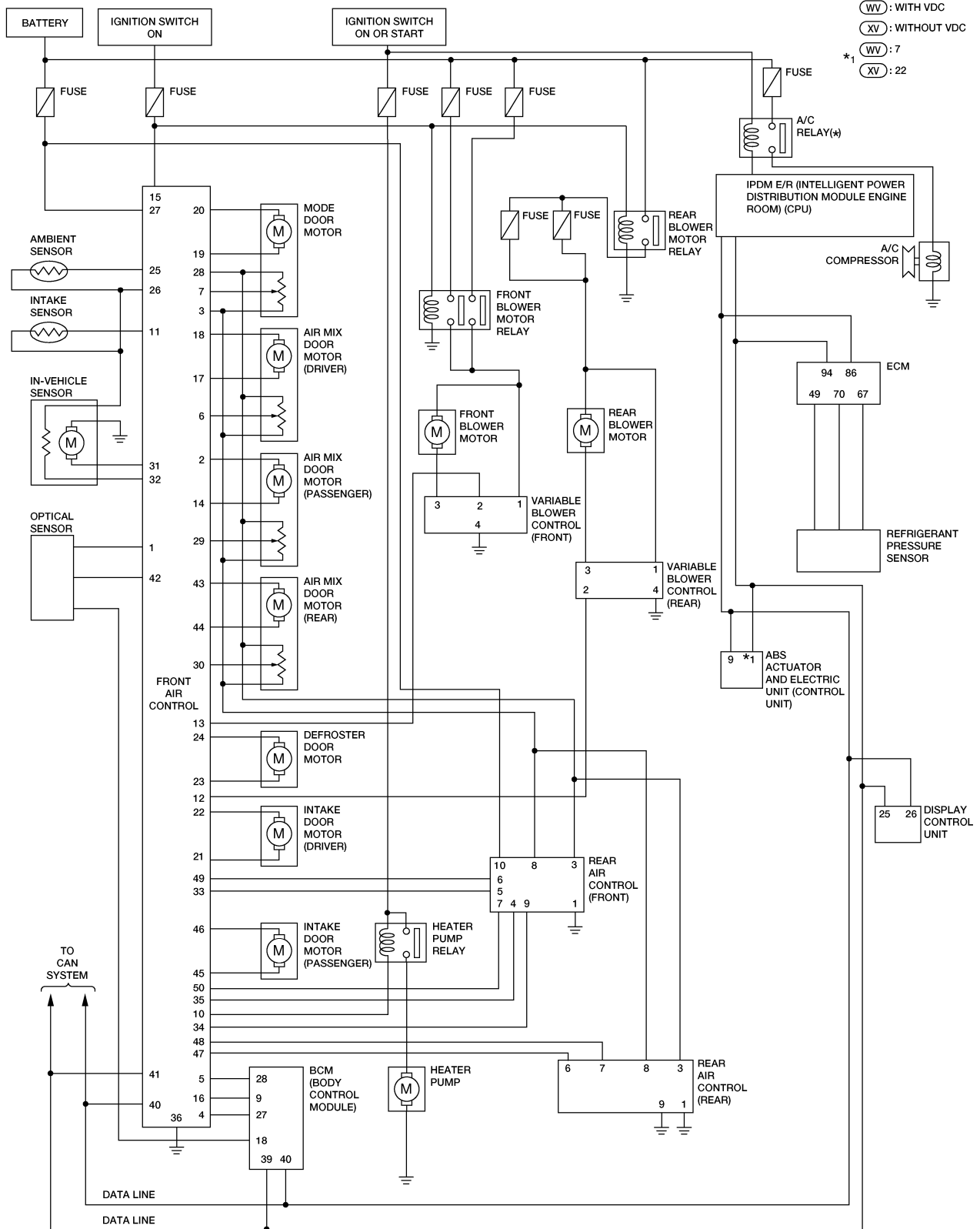

(WV) : WITH VDC
 (XV) : WITHOUT VDC
 *1 (WV) : 7
 (XV) : 22

* : THIS RELAY IS BUILT INTO THE IPDM E/R (INTELLIGENT POWER DISTRIBUTION MODULE ENGINE ROOM)

WJWA0433E

TROUBLE DIAGNOSIS

Wiring Diagram — A/C,A —

EJS004JX

ATC-A/C,A-01

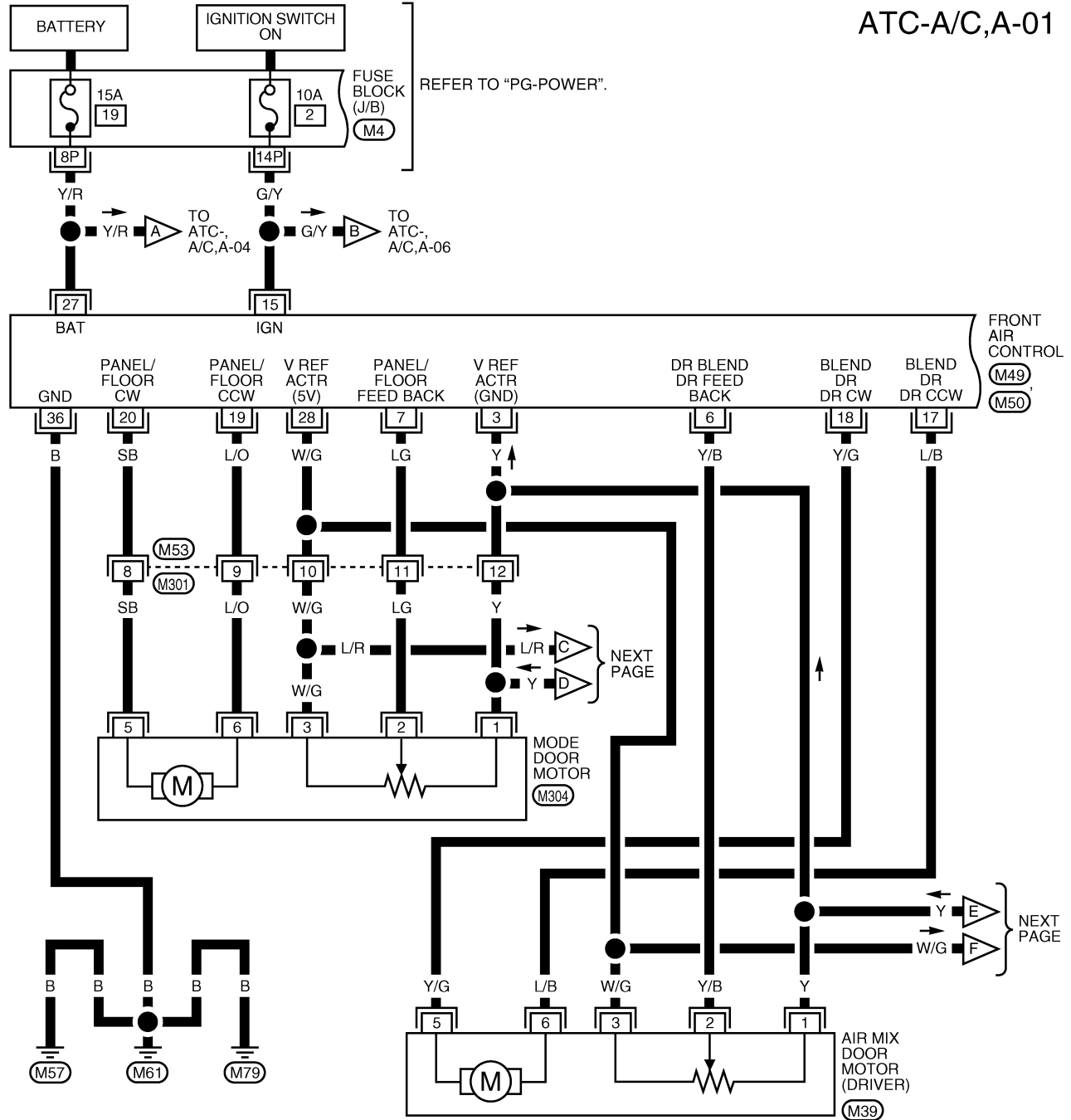

A
B
C
D
E
F
G
H
I
K
L
M

ATC

1P	2P	3P	4P	5P	6P	7P	M4	M39	M304
8P	9P	10P	11P	12P	13P	14P	W	B	B

1	2	3	4	5	6	7	8	9	10	11	12	13	M49	27	28	29	30	31	32	33	34	35	36	37	38	39	M50
14	15	16	17	18	19	20	21	22	23	24	25	26	B	40	41	42	43	44	45	46	47	48	49	50	51	52	L

1	2	3	4	5	6	7	M53		
8	9	10	11	12	13	14	15	16	W

WJWA0434E

TROUBLE DIAGNOSIS

ATC-A/C,A-02

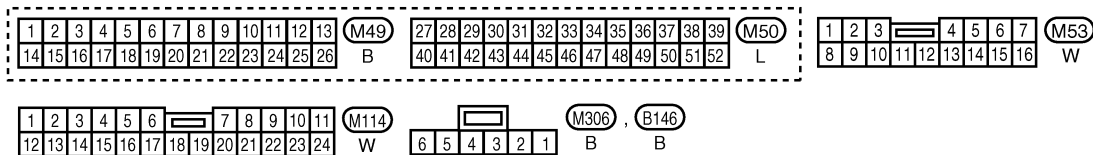
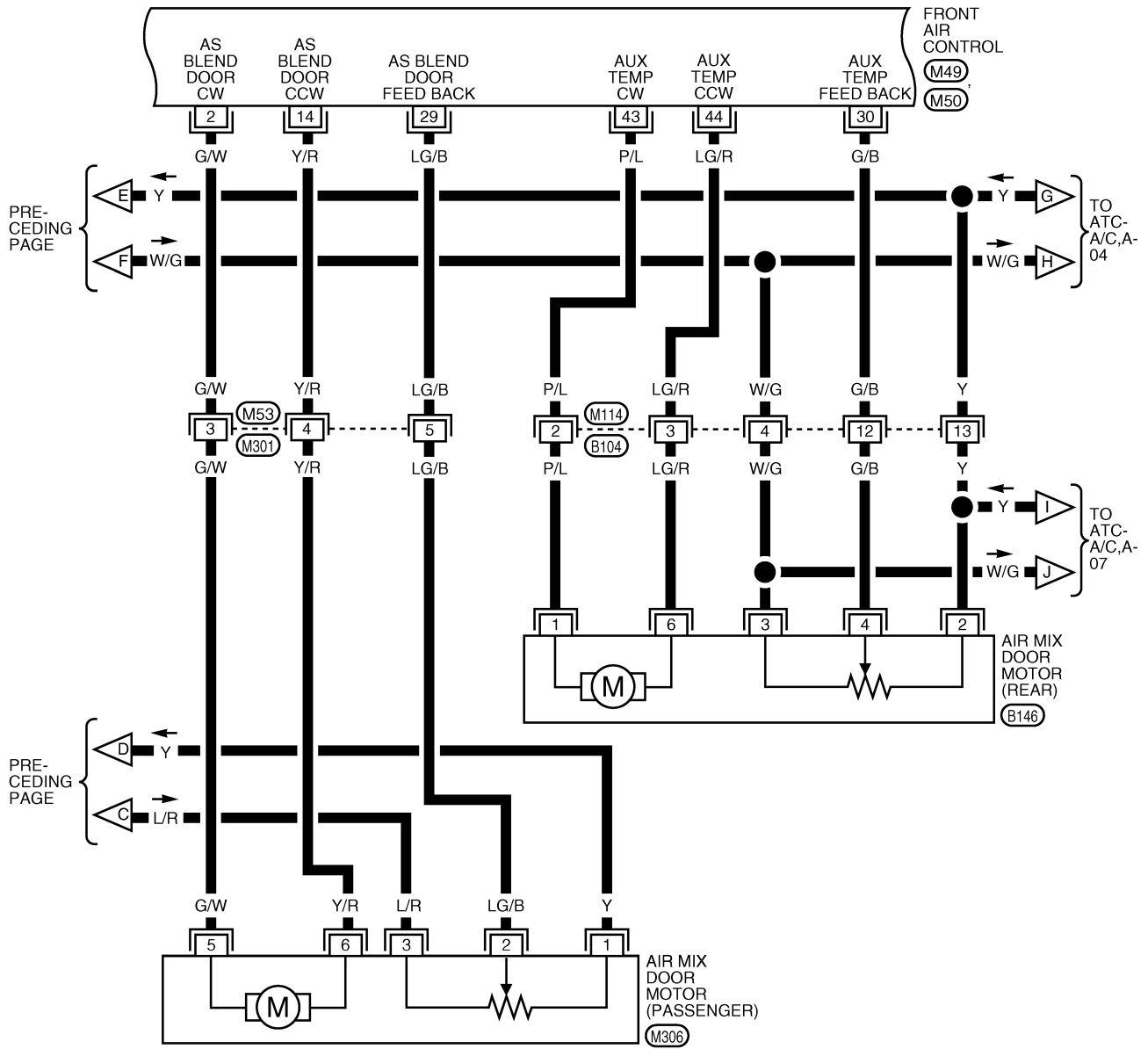

WJWA0435E

TROUBLE DIAGNOSIS

ATC-A/C,A-03

▬ : DATA LINE

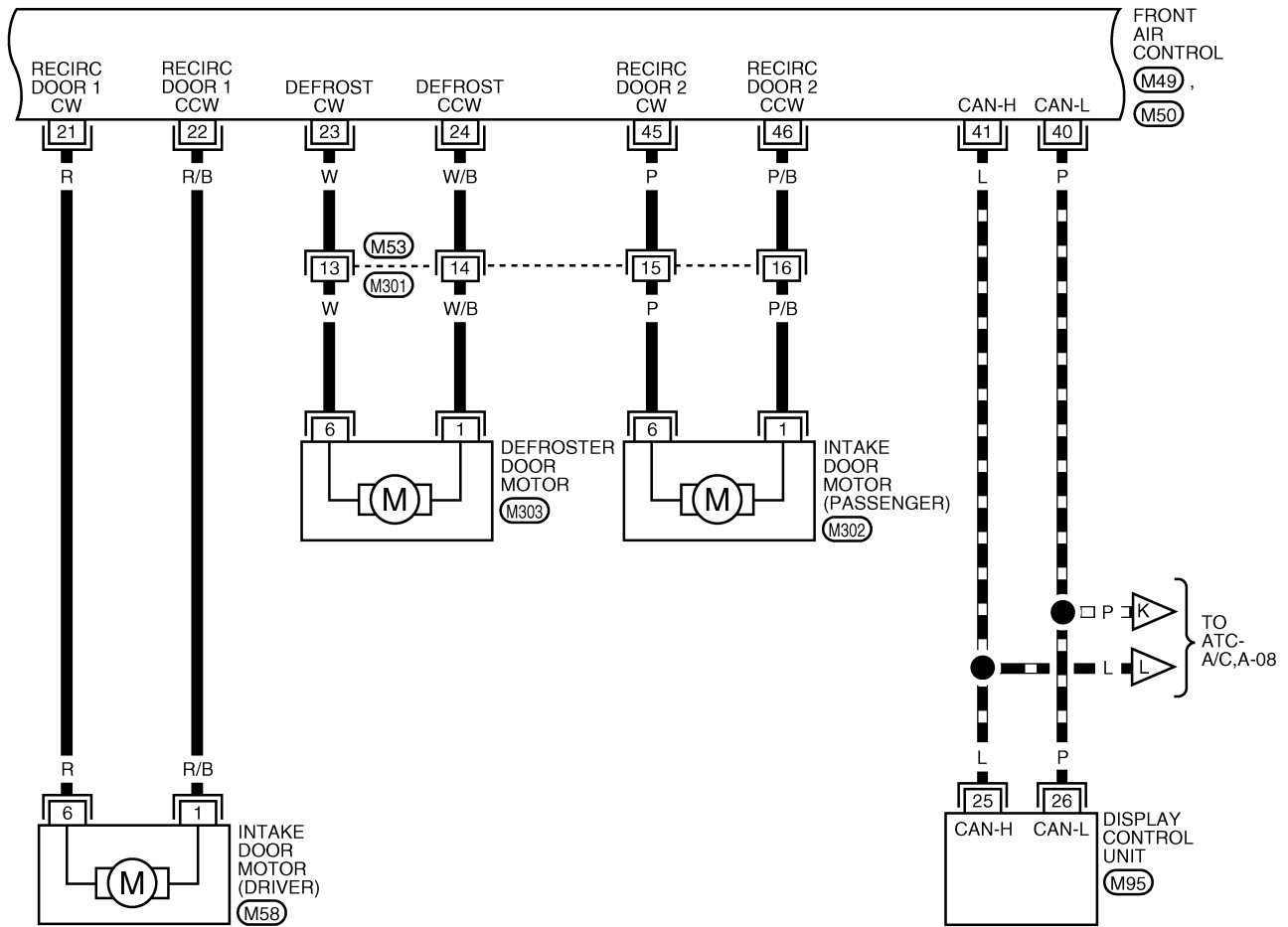

A
B
C
D
E
F
G
H
I
K
L
M

ATC

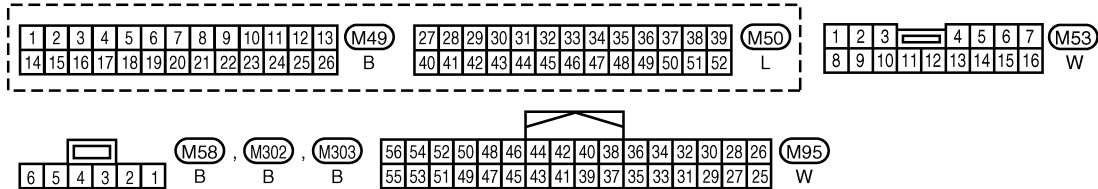

WJWA0436E

TROUBLE DIAGNOSIS

ATC-A/C,A-04

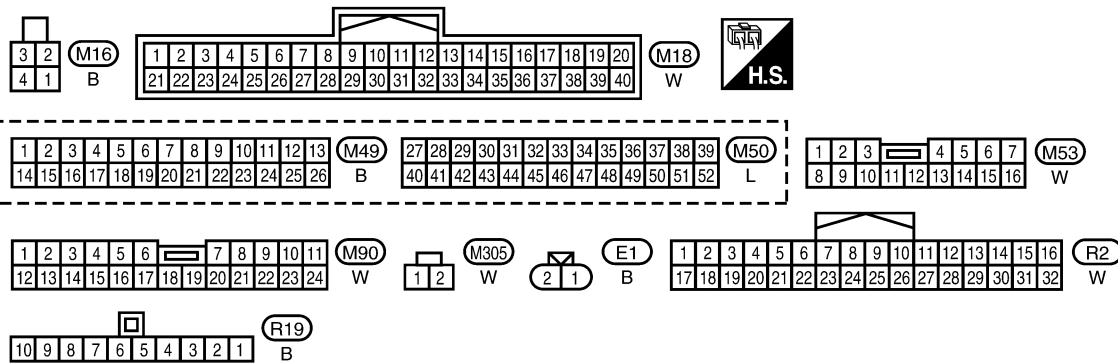
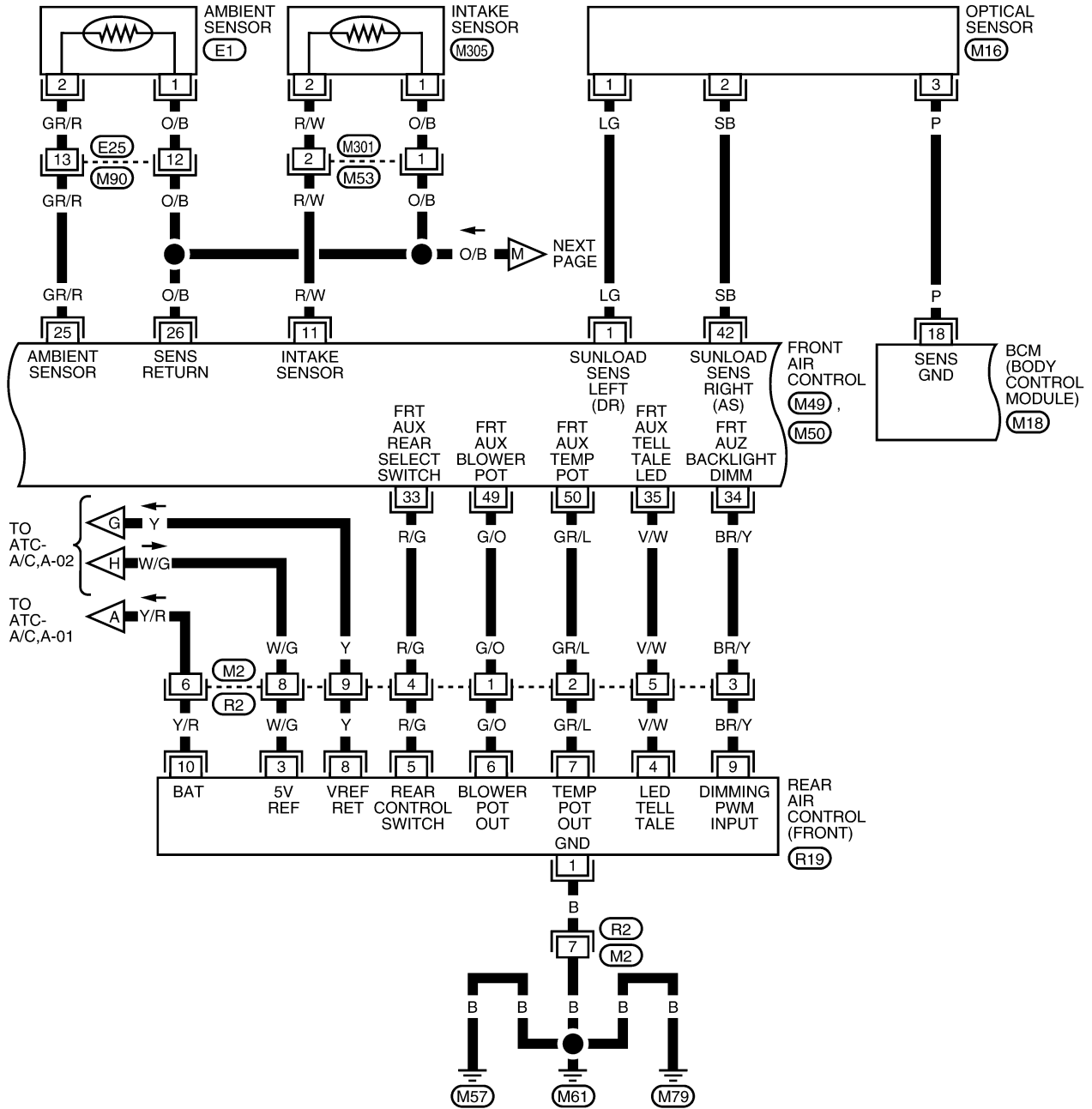

WJWA0437E

TROUBLE DIAGNOSIS

ATC-A/C,A-05

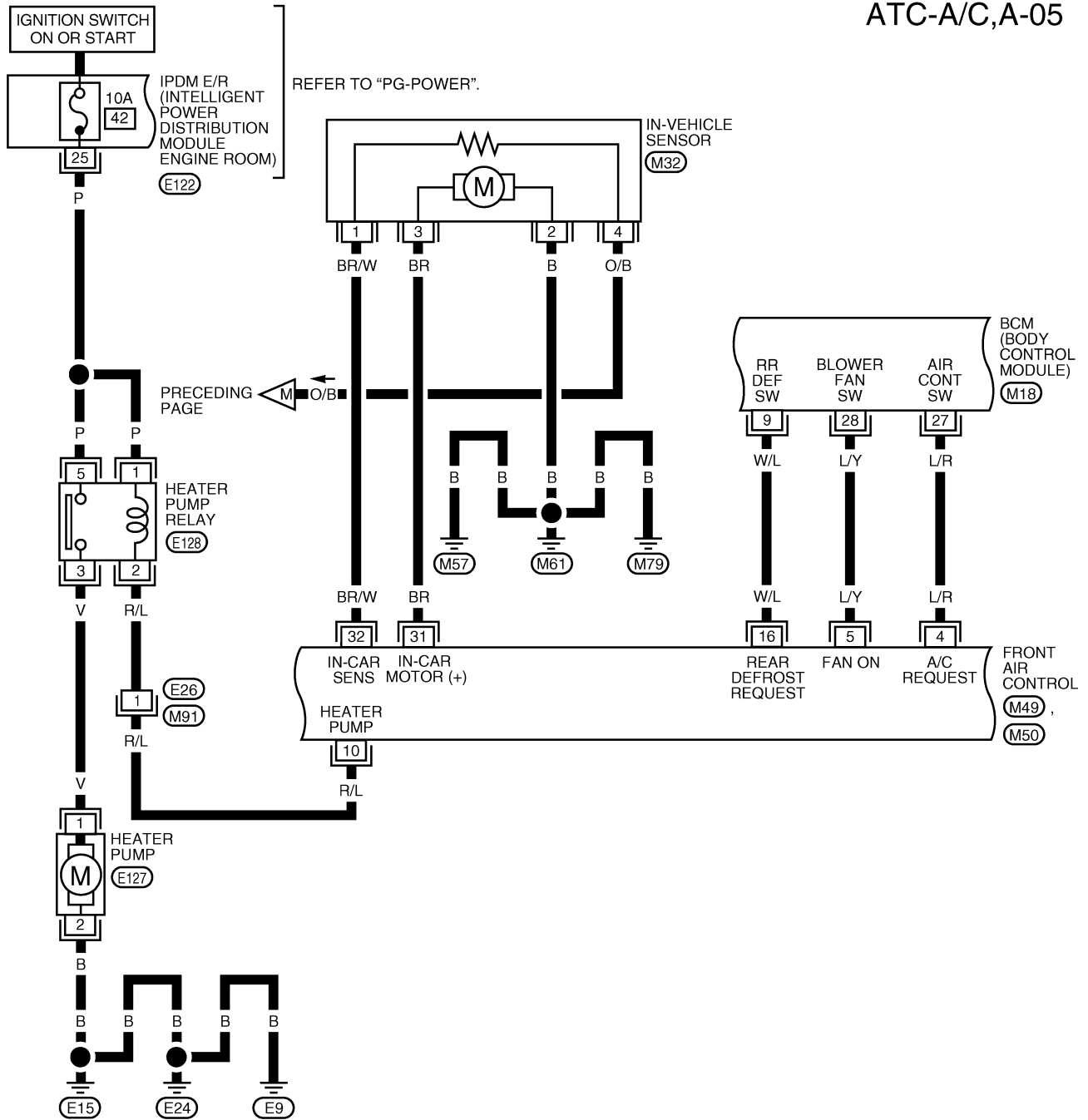

A
B
C
D
E
F
G
H
I
ATC
K
L
M

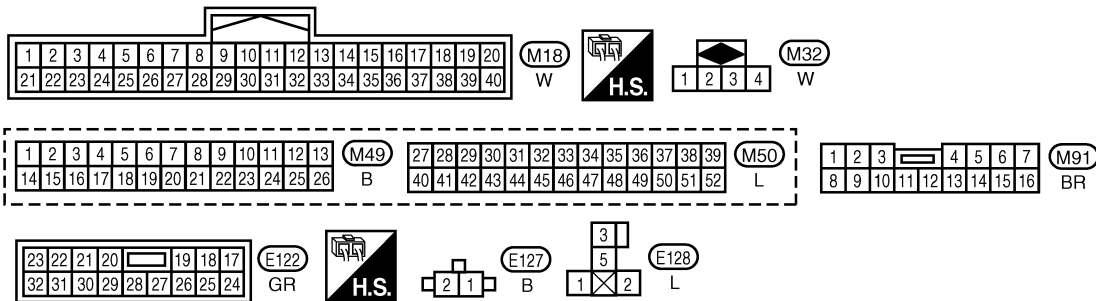

WJWA0438E

TROUBLE DIAGNOSIS

ATC-A/C,A-06

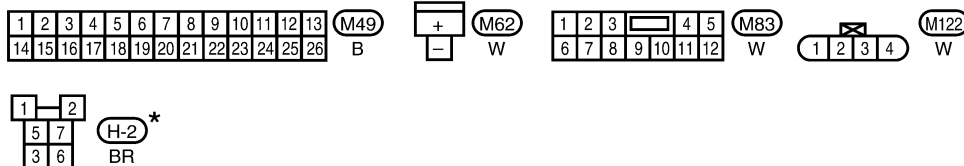
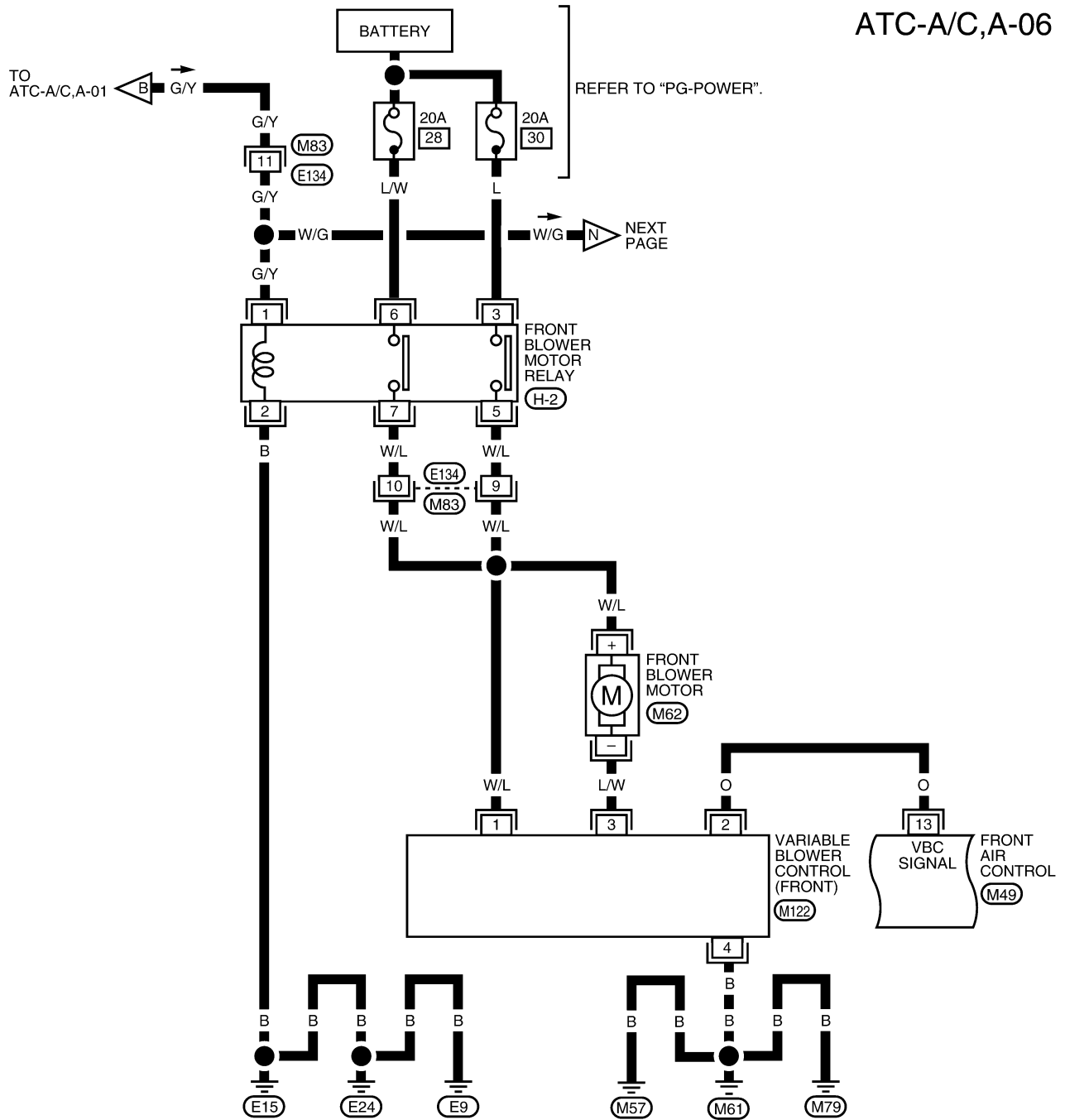

*: THIS CONNECTOR IS NOT SHOWN IN "HARNESS LAYOUT" OF PG SECTION.

WJWA0439E

TROUBLE DIAGNOSIS

ATC-A/C,A-07

PRECEDING PAGE

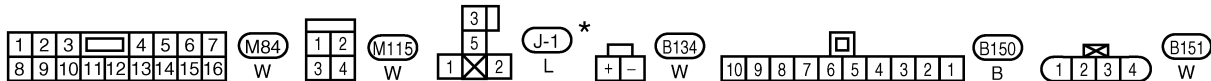
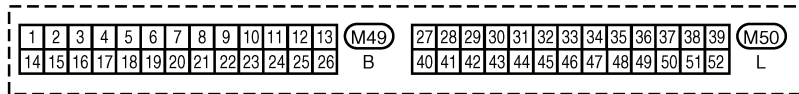
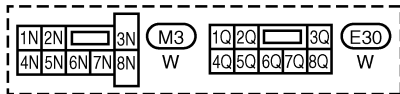
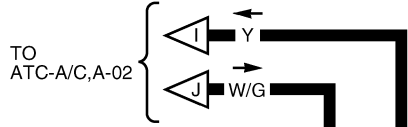
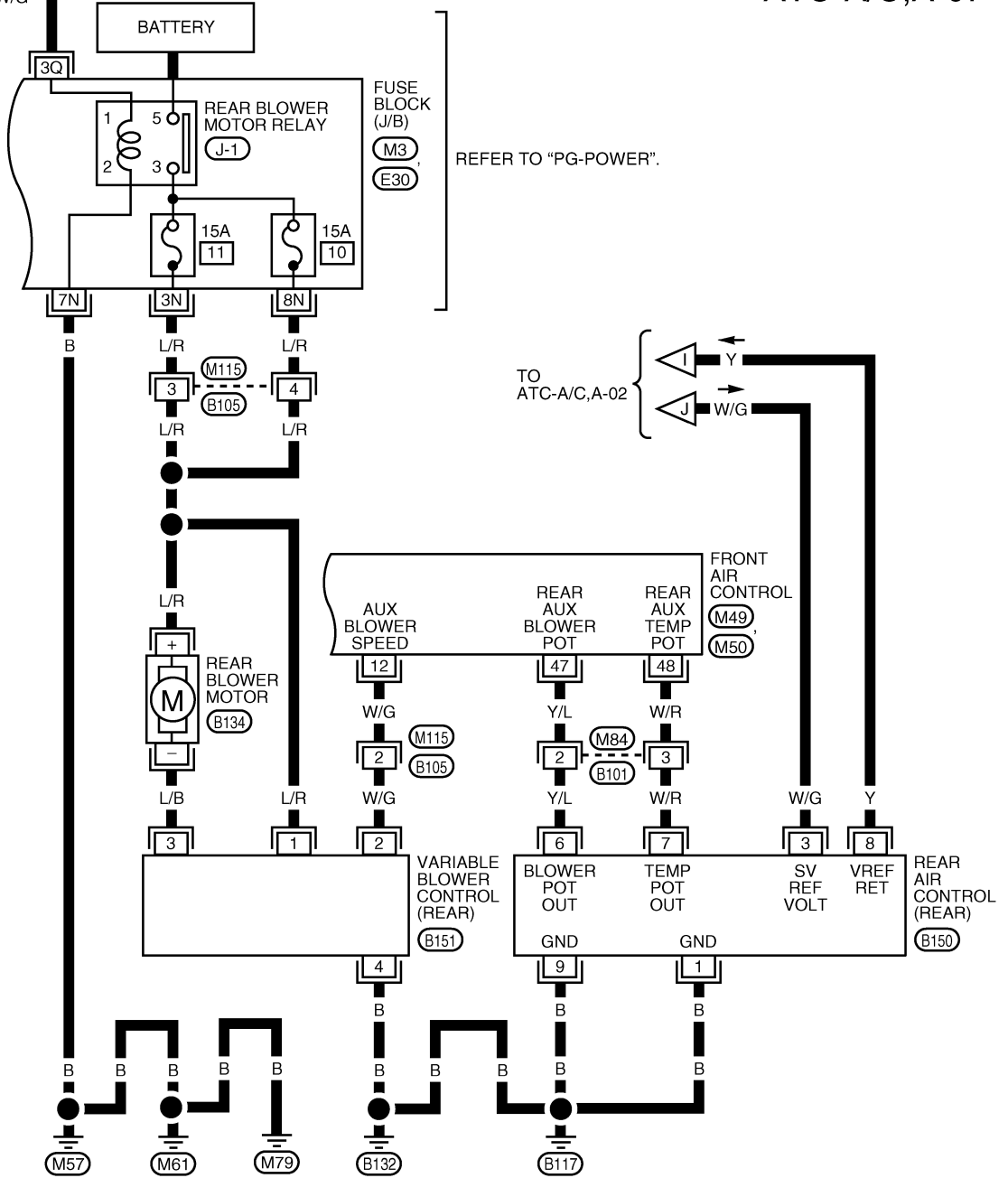

* : THIS CONNECTOR IS NOT SHOWN IN "HARNESS LAYOUT" OF PG SECTION.

LJWA0012E

TROUBLE DIAGNOSIS

ATC-A/C,A-08

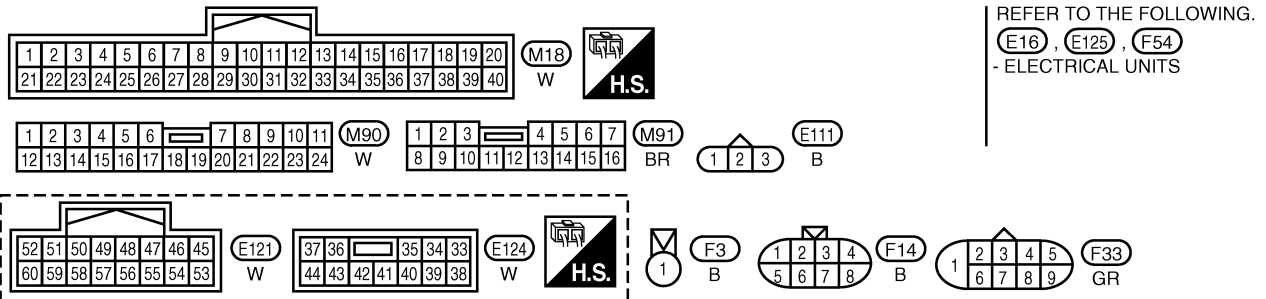
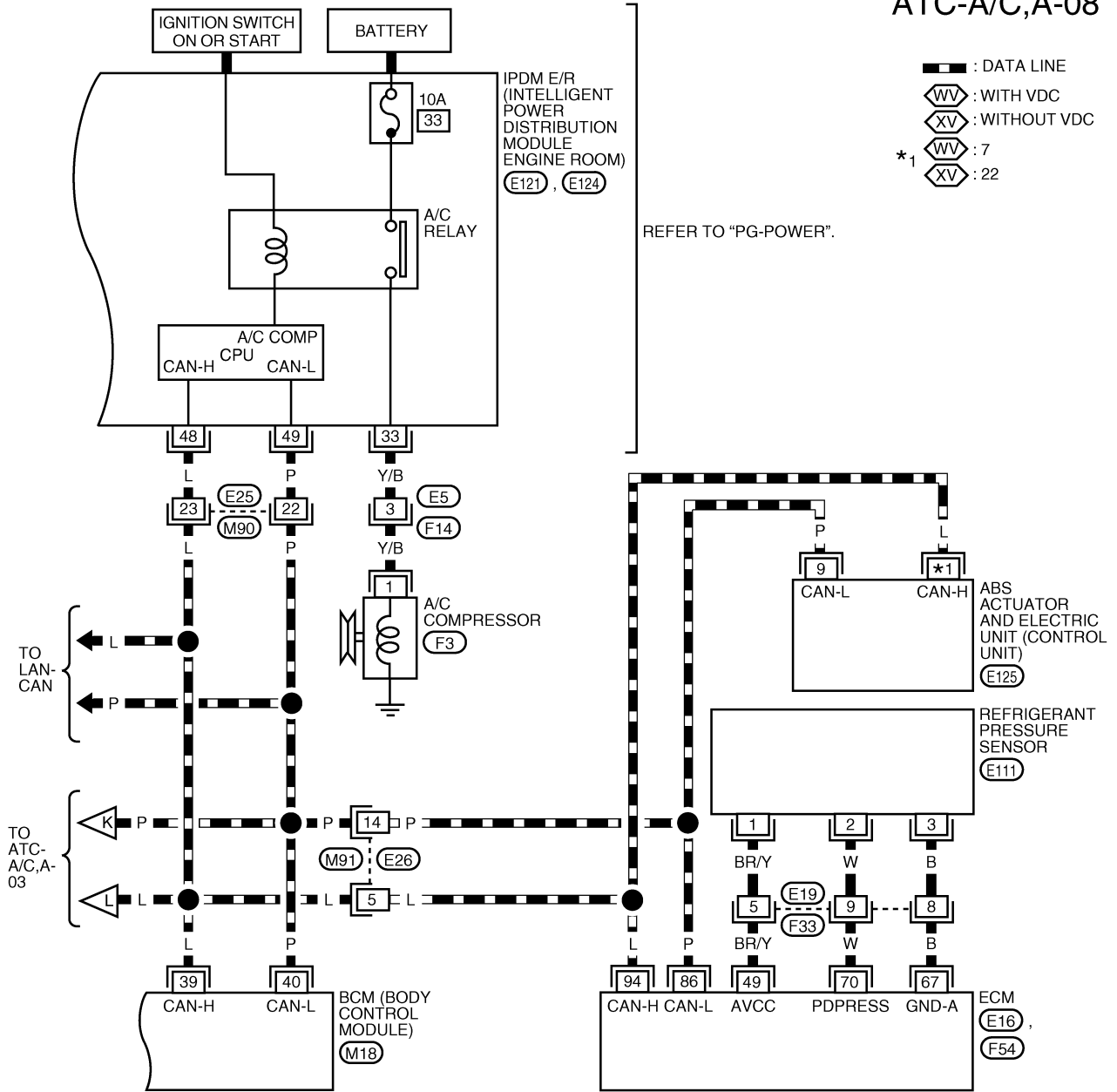

WJWA0440E

TROUBLE DIAGNOSIS

Front Air Control Terminals and Reference Value FRONT AIR CONTROL HARNESS CONNECTOR TERMINAL LAYOUT

EJS004JY

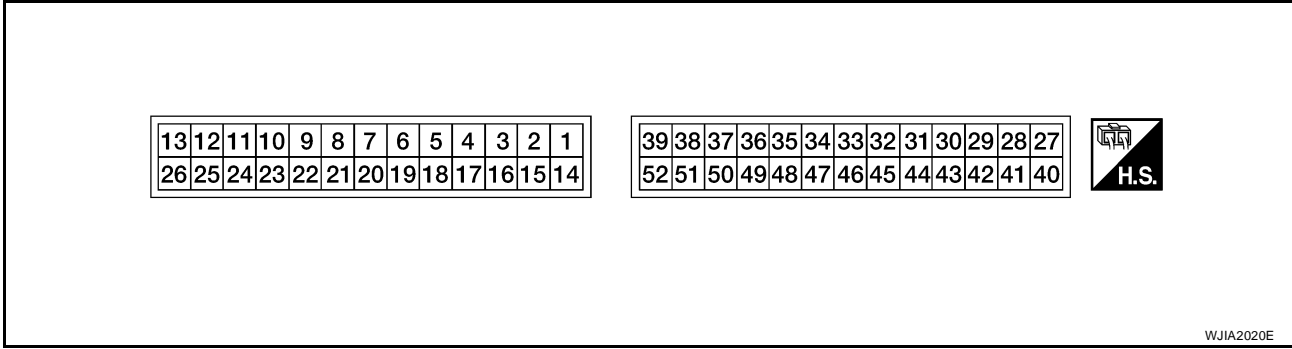

TERMINALS AND REFERENCE VALUES FOR FRONT AIR CONTROL

Terminal No.	Wire Color	Item	Ignition Switch	Condition	Voltage (V) (Approx.)
1	LG	Optical sensor (driver)	ON	-	0 - 5V
2	G/W	Air mix door motor (passenger) CW	ON	Clockwise rotation	Battery voltage
3	Y	Sensor ground	ON	-	0V
4	L/R	Compressor ON signal	ON	A/C switch OFF	5V
			ON	A/C switch ON	0V
5	L/Y	Fan ON signal	ON	Fan switch OFF	5V
			ON	Fan switch ON	0V
6	Y/B	Air mix door motor (driver) feedback	ON	-	0 - 5V
7	LG	Mode door motor feedback	ON	-	0 - 5V
8	R/L	Illumination +	ON	Park lamps ON	Battery voltage
9	R/Y	Illumination -	-	Park lamps ON	
10	R/L	Heater pump	ON	Heater pump OFF	Battery voltage
				Heater pump ON	0V
11	R/W	Intake sensor	ON	-	0 - 5V
12	W/G	Aux blower speed	ON	-	0 - 5V
13	O	Variable blower control	ON	-	0 - 5V
14	Y/R	Air mix door motor (passenger) CCW	ON	Counterclockwise rotation	Battery voltage
15	G/Y	Power supply for IGN	ON	-	Battery voltage
16	W/L	Rear defroster request	ON	-	Battery voltage
17	L/B	Air mix door motor (driver) CCW	ON	Counterclockwise rotation	Battery voltage
18	Y/G	Air mix door motor (driver) CW	ON	Clockwise rotation	Battery voltage
19	L/O	Mode door motor CCW	ON	Counterclockwise rotation	Battery voltage
20	SB	Mode door motor CW	ON	Clockwise rotation	Battery voltage
21	R	Intake door motor (driver) CW	ON	Counterclockwise rotation	Battery voltage
22	R/B	Intake door motor (driver) CCW	ON	Clockwise rotation	Battery voltage
23	W	Defroster door motor CW	ON	Clockwise rotation	Battery voltage
24	W/B	Defroster door motor CCW	ON	Counterclockwise rotation	Battery voltage

TROUBLE DIAGNOSIS

Terminal No.	Wire Color	Item	Ignition Switch	Condition	Voltage (V) (Approx.)
25	GR/R	Ambient sensor	ON	-	0 - 5V
26	O/B	Sensor return	ON	-	0 - 5V
27	Y/R	Power supply for BAT	-	-	Battery voltage
28	W/G	Sensor power	ON	-	5V
29	LG/B	Air mix door motor (passenger) feedback	ON	-	0 - 5V
30	G/B	Air mix door motor (rear) feedback	ON	-	0 - 5V
31	BR	In-vehicle sensor motor (+)	ON	-	Battery voltage
32	BR/W	In-vehicle sensor signal	ON	-	0 - 5V
33	R/G	Front AUX (rear)	ON	-	0 - 5V
34	BR/Y	Front aux backlight dim	ON	Headlamps OFF	Battery voltage
35	V/W	Front aux tell tale LED	ON	Tell tale OFF	Battery voltage
36	B	Ground	-	-	0V
40	P	CAN-L	ON	-	-
41	L	CAN-H	ON	-	-
42	SB	Optical sensor (passenger)	ON	-	0 - 5V
43	P/L	Air mix door motor (rear) CW	ON	Clockwise rotation	Battery voltage
44	LG/R	Air mix door motor (rear) CCW	ON	Counterclockwise rotation	Battery voltage
45	P	Intake door motor (passenger) CW	ON	Clockwise rotation	Battery voltage
46	P/B	Intake door motor (passenger) CCW	ON	Counterclockwise rotation	Battery voltage
47	Y/L	Rear aux blower pot	ON	Rear blower motor	0 - 5V
48	W/R	Rear aux temp pot	ON	Rear air control (rear) temperature control dial	0 - 5V
49	G/O	Front aux blower pot	ON	Rear air control (front) blower motor	0 - 5V
50	GR/L	Front aux temp pot	ON	Rear air control (front) temperature control dial	0 - 5V

TROUBLE DIAGNOSIS

EJS004JZ

A/C System Self-diagnosis Function DESCRIPTION

NOTE:

If using CONSULT-II refer to [ATC-32, "SELF-DIAGNOSIS"](#) .

The self-diagnostic system diagnoses sensors, CAN system, battery voltage, and stuck button on front air control. Refer to applicable sections (items) for details. Shifting from usual control to the self-diagnostic system is accomplished by the following:

On the AV switch, hold the memory "4" button and rotate the audio volume control dial until the Self-Diagnostic screen shows on the display. Scroll down and select "Confirmation/Adjustment" with the joystick. Select "Auto Climate Control" with the joystick to start the self-test. The fan bars will flash on the display during the self-test, and then the fault codes (if any are present) will display in the ambient temperature area. Refer to [ATC-54, "SELF-DIAGNOSIS CODE CHART"](#) . The fault codes will continue to scroll until self-diagnostic mode is exited. To exit self-diagnostic mode, press the "BACK" button on the AV switch repeatedly until the screen displays the HVAC status.

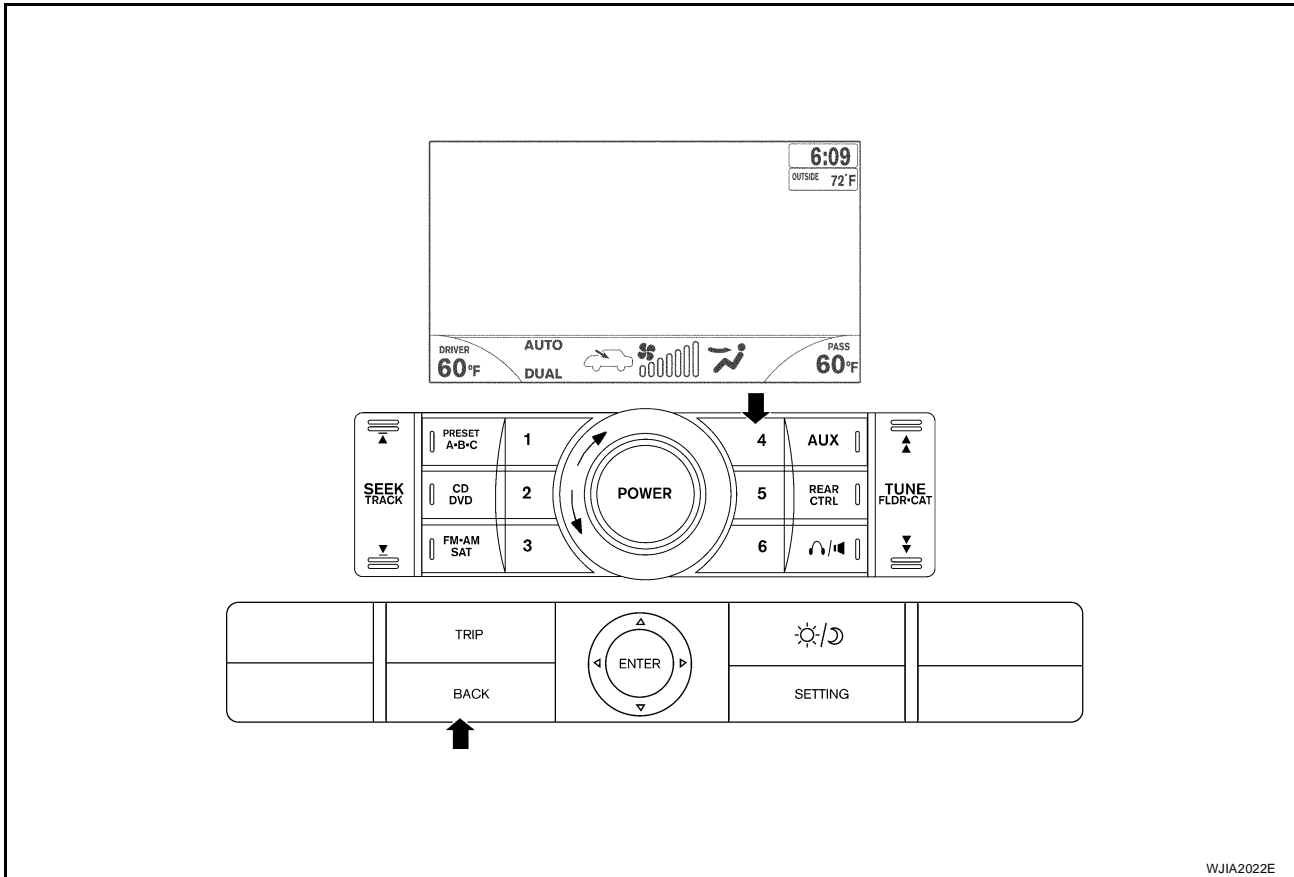

WJIA2022E

TROUBLE DIAGNOSIS

SELF-DIAGNOSIS CODE CHART

NOTE:

If using CONSULT-II refer to [ATC-32, "SELF-DIAGNOSIS"](#) .

Code No.	Reference page	
02	EE changed by calibration	ATC-160, "FRONT AIR CONTROL"
03	Battery voltage out of range	SC-4, "BATTERY"
12	Air mix door motor (passenger) circuit failure	ATC-77, "DIAGNOSTIC PROCEDURE FOR AIR MIX DOOR MOTOR (PASSENGER)"
20	BCM not responding to A/C request	MTC-114, "Magnet Clutch Circuit"
21	BCM not responding to rear defroster request	GW-87, "REAR WINDOW DEFOGGER"
22	Air mix door motor (driver) circuit failure	ATC-73, "DIAGNOSTIC PROCEDURE FOR AIR MIX DOOR MOTOR (DRIVER)"
30	In-vehicle sensor circuit out of range (low)	ATC-151, "In-vehicle Sensor Circuit"
31	In-vehicle sensor circuit out of range (high)	
38	Air mix door motor (rear) circuit failure	ATC-81, "DIAGNOSTIC PROCEDURE FOR AIR MIX DOOR MOTOR (REAR)"
40	Ambient sensor circuit short	ATC-148, "Ambient Sensor Circuit"
41	Ambient sensor circuit open	
44	In-vehicle sensor motor circuit open	ATC-151, "In-vehicle Sensor Circuit"
46	In-vehicle sensor motor circuit short	
50	Optical sensor (driver) circuit open or short	ATC-155, "Optical Sensor Circuit"
52	Optical sensor (passenger) circuit open or short	
56	Intake sensor circuit short	ATC-158, "Intake Sensor Circuit"
57	Intake sensor circuit open	
62	Defroster door drive short /open/out of limits	ATC-92, "Defroster Door Motor Circuit"
72	Intake door motor (passenger) short/open	ATC-90, "DIAGNOSTIC PROCEDURE FOR INTAKE DOOR MOTOR (PASSENGER)"
80	CAN bus fault	LAN-7, "TROUBLE DIAGNOSIS"
82	Intake door motor (driver) short/open	ATC-88, "DIAGNOSTIC PROCEDURE FOR INTAKE DOOR MOTOR (DRIVER)"
90	Stuck button	ATC-160, "FRONT AIR CONTROL"
92	Mode door motor short/open/out of limits	ATC-62, "Mode Door Motor Circuit"

TROUBLE DIAGNOSIS

EJS004K0

Operational Check (Front)

The purpose of the operational check is to confirm that the system operates properly.

Conditions : Engine running and at normal operating temperature

CHECKING MEMORY FUNCTION

1. Set the temperature to 32°C (90°F).
2. Rotate the blower control dial counterclockwise (hold blower control dial until system shuts OFF).
3. Turn ignition switch OFF.
4. Turn ignition switch ON.
5. Press the AUTO switch.
6. Confirm that the set temperature remains at previous temperature.
7. Rotate the blower control dial counterclockwise (hold blower control dial until system shuts OFF).

If NG, go to trouble diagnosis procedure for [ATC-147, "Memory Function"](#).

If OK, continue with next check.

CHECKING BLOWER

1. Rotate blower control dial clockwise to turn system on. Blower should operate on low speed. The fan display should have one bar lit (on display).
2. Rotate the blower control dial clockwise and continue checking blower speed and fan display until all speeds are checked.
3. Leave blower on maximum speed.

If NG, go to trouble diagnosis procedure for [ATC-98, "DIAGNOSTIC PROCEDURE FOR BLOWER MOTOR"](#).

If OK, continue with next check.

CHECKING DISCHARGE AIR

1. Press each mode switch and press DEF () switch.
2. Each position indicator should change shape (on display).
3. Confirm that discharge air comes out according to the air distribution table. Refer to [ATC-29, "Discharge Air Flow"](#).





Mode door position is checked in the next step.

If NG, go to trouble diagnosis procedure for [ATC-62, "Mode Door Motor Circuit"](#).

If OK, continue with next check.



NOTE:

Confirm that the compressor clutch is engaged (sound or visual inspection) and intake door position is at fresh when the DEF or D/F is selected.

Discharge air flow			
Mode door position	Air outlet/distribution		
	Vent	Foot	Defroster
	100%	–	–
	50%	50%	–
	–	75%(100%)	25% (–)
	–	60%	40%
	–	–	100%

() : Manually control WJJA0528E

CHECKING RECIRCULATION

1. Select vent () mode switch and then press recirculation () switch one time. Recirculation indicator should illuminate.
2. Press recirculation () switch one more time. Recirculation indicator should go off.
3. Listen for intake door position change (blower sound should change slightly).

If NG, go to trouble diagnosis procedure for [ATC-86, "Intake Door Motor Circuit"](#).

If OK, continue with next check.

CHECKING TEMPERATURE DECREASE

1. Rotate temperature dial counterclockwise (driver side or passenger side) until 16°C (60°F) is displayed.
2. Check for cold air at appropriate discharge air outlets.

If NG, listen for sound of air mix door motor operation. If OK, go to trouble diagnosis procedure for [ATC-130, "Insufficient Cooling"](#). If air mix door motor appears to be malfunctioning, go to [ATC-73, "DIAGNOSTIC PROCEDURE FOR AIR MIX DOOR MOTOR \(DRIVER\)"](#) or [ATC-77, "DIAGNOSTIC PROCEDURE FOR AIR MIX DOOR MOTOR \(PASSENGER\)"](#).

A
B
C
D
E
F
G
H
I
K
L
M

ATC

TROUBLE DIAGNOSIS

If OK, continue with next check.

CHECKING TEMPERATURE INCREASE

1. Rotate temperature dial clockwise (driver side or passenger side) until 32°C (90°F) is displayed.
2. Check for hot air at appropriate discharge air outlets.

If NG, listen for sound of air mix door motor operation. If OK, go to trouble diagnosis procedure for [ATC-138, "Insufficient Heating"](#) . If air mix door motor appears to be malfunctioning, go to [ATC-73, "DIAGNOSTIC PROCEDURE FOR AIR MIX DOOR MOTOR \(DRIVER\)"](#) or [ATC-77, "DIAGNOSTIC PROCEDURE FOR AIR MIX DOOR MOTOR \(PASSENGER\)"](#) .

If OK, continue with next check.

CHECK A/C SWITCH

1. Press A/C switch when AUTO switch is ON, or in manual mode.
2. A/C switch indicator will turn ON.
 - Confirm that the compressor clutch engages (sound or visual inspection).

If NG, go to trouble diagnosis procedure for [ATC-124, "Magnet Clutch Circuit"](#) .

If OK, continue with next check.

CHECKING AUTO MODE

1. Press AUTO switch.
2. Display should indicate AUTO.
 - If ambient temperature is warm, and selected temperature is cool, confirm that the compressor clutch engages (sound or visual inspection). (Discharge air and blower speed will depend on ambient, in-vehicle, and set temperatures.)

If NG, go to trouble diagnosis procedure for [ATC-59, "Power Supply and Ground Circuit for Front Air Control"](#) , then if necessary, trouble diagnosis procedure for [ATC-124, "Magnet Clutch Circuit"](#) .

If all operational checks are OK (symptom cannot be duplicated), go to [ATC-36, "How to Perform Trouble Diagnosis for Quick and Accurate Repair"](#) and perform tests as outlined. If symptom appears, refer to [ATC-36, "How to Perform Trouble Diagnosis for Quick and Accurate Repair"](#) , [ATC-36, "SYMPTOM TABLE"](#) and perform applicable trouble diagnosis procedures.

TROUBLE DIAGNOSIS

EJS0053F

Operational Check (Rear)

The purpose of the operational check is to confirm that the system operates properly.

Conditions : Engine running and at normal operating temperature

CHECKING REAR BLOWER MOTOR

1. Press the AUTO switch on the front air control.
2. Rotate rear air control (front) blower control dial to low speed.
3. Rotate the blower control dial clockwise and continue checking blower speed until all speeds are checked.
4. Leave blower on maximum speed.
5. Press the REAR CTRL switch from the rear air control (front).
6. Rotate rear air control (rear) blower control dial to low speed.
7. Rotate the blower control dial clockwise and continue checking blower speed until all speeds are checked.
8. Leave blower on maximum speed.

If NG, go to trouble diagnosis procedure for [ATC-105, "Rear Blower Motor Circuit"](#) .

If OK, continue with next check.

CHECKING REAR DISCHARGE AIR

1. Rotate the rear air control (front) temperature/mode control dial from maximum heat to maximum cold.
2. Confirm that discharge air comes out according to the air distribution table. Refer to [ATC-29, "REAR"](#) .
3. Press the REAR CTRL switch from the rear air control (front).
4. Rotate the rear air control (rear) temperature/mode control dial from maximum heat to maximum cold.
5. Confirm that discharge air comes out according to the air distribution table. Refer to [ATC-29, "REAR"](#) .

Air mix door position is checked in the next step.

If NG, go to [ATC-81, "DIAGNOSTIC PROCEDURE FOR AIR MIX DOOR MOTOR \(REAR\)"](#) .

If OK, continue with next check.

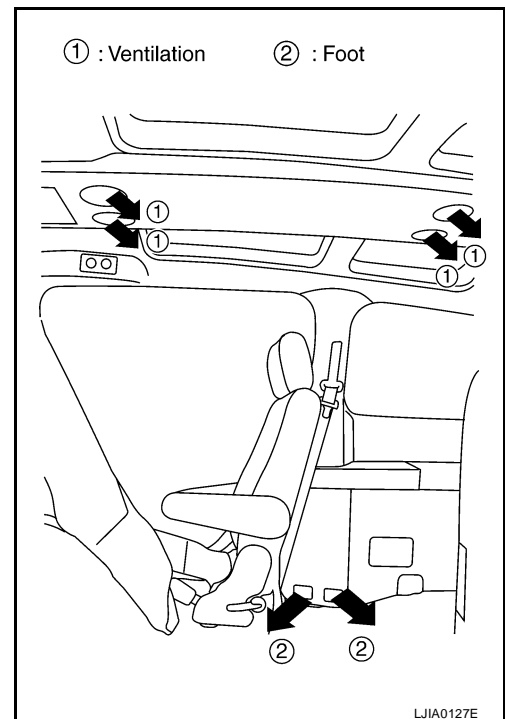

CHECKING REAR TEMPERATURE DECREASE

1. Rotate the rear air control (front) temperature/mode control dial counterclockwise to maximum cold.
2. Check for cold air at appropriate discharge air outlets.
3. Press the REAR CTRL switch from the rear air control (front).
4. Rotate the rear air control (rear) temperature/mode control dial counterclockwise to maximum cold.
5. Check for cold air at appropriate discharge air outlets.

If NG, listen for sound of air mix door motor operation. If OK, go to trouble diagnosis procedure for [ATC-130, "Insufficient Cooling"](#) . If air mix door motor appears to be malfunctioning, go to [ATC-81, "DIAGNOSTIC PROCEDURE FOR AIR MIX DOOR MOTOR \(REAR\)"](#) .

If OK, continue with next check.

TROUBLE DIAGNOSIS

CHECKING REAR TEMPERATURE INCREASE

1. Rotate the rear air control (front) temperature/mode control dial clockwise to maximum heat.
2. Check for hot air at appropriate discharge air outlets.
3. Press the REAR CTRL switch from the rear air control (front).
4. Rotate the rear air control (rear) temperature/mode control dial clockwise to maximum heat.
5. Check for hot air at appropriate discharge air outlets.

If NG, listen for sound of air mix door motor operation. If OK, go to trouble diagnosis procedure for [ATC-138, "Insufficient Heating"](#) . If air mix door motor appears to be malfunctioning, go to [ATC-81, "DIAGNOSTIC PROCEDURE FOR AIR MIX DOOR MOTOR \(REAR\)"](#) .

If NG, go to trouble diagnosis procedure for [ATC-118, "Rear Air Temperature Control Circuit"](#) .

If all operational checks are OK (symptom cannot be duplicated), go to [ATC-36, "How to Perform Trouble Diagnosis for Quick and Accurate Repair"](#) and perform tests as outlined. If symptom appears, refer to [ATC-36, "SYMPTOM TABLE"](#) and perform applicable trouble diagnosis procedures.

TROUBLE DIAGNOSIS

Power Supply and Ground Circuit for Front Air Control

EJS004K1

SYMPTOM: A/C system does not come on.

INSPECTION FLOW

1. CONFIRM SYMPTOM BY PERFORMING OPERATIONAL CHECK - AUTO MODE

1. Press AUTO switch.
2. Display should indicate AUTO. Confirm that the compressor clutch engages (sound or visual inspection). (Discharge air and blower speed will depend on ambient, in-vehicle and set temperatures.)

Can a symptom be duplicated?

- YES >> GO TO 3.
NO >> GO TO 2.

2. PERFORM COMPLETE OPERATIONAL CHECK

Perform a complete operational check and check for any symptoms. Refer to [ATC-55, "Operational Check \(Front\)"](#).

Can a symptom be duplicated

- YES >> Refer to [ATC-36, "SYMPTOM TABLE"](#).
NO >> System OK.

3. CHECK FOR SERVICE BULLETINS

Check for any service bulletins.

>> GO TO 4.

4. CHECK POWER AND GROUND CIRCUIT

Check main power supply and ground circuit. Refer to [ATC-60, "DIAGNOSTIC PROCEDURE FOR A/C SYSTEM"](#).

OK or NG

- OK >> System OK.
NO >> Replace front air control. Refer to [ATC-160, "FRONT AIR CONTROL"](#).

A

B

C

D

E

F

G

H

I

ATC

K

L

M

TROUBLE DIAGNOSIS

COMPONENT DESCRIPTION

Front Air Control

The front air control has a built-in microcomputer which processes information sent from various sensors needed for air conditioner operation. The air mix door motors, mode door motor, intake door motors, defroster door motor, blower motor and compressor are then controlled.

The front air control is unitized with control mechanisms. When the various switches and temperature dials are operated, data is input to the front air control.

Self-diagnostic functions are also built into the front air control to provide quick check of malfunctions in the auto air conditioner system.

Potential Temperature Control (PTC)

There are two PTCs (passenger and driver) (1) built into the front air control. They can be set from 16°C (60°F) to 32°C (90°F) temperature range by rotating the temperature dial. The set temperature is displayed.

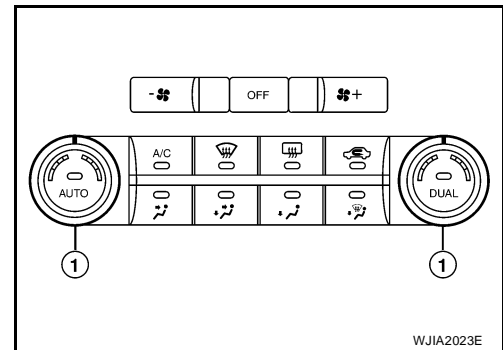

DIAGNOSTIC PROCEDURE FOR A/C SYSTEM

SYMPTOM: A/C system does not come on.

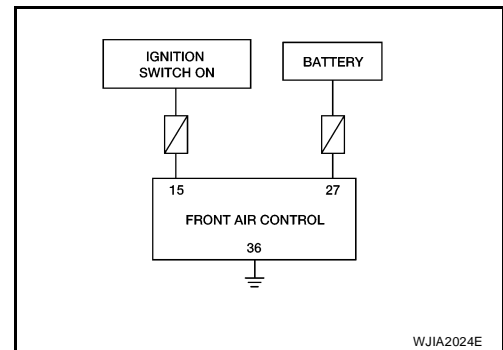

1. CHECK POWER SUPPLY CIRCUITS FOR FRONT AIR CONTROL

1. Disconnect front air control connectors.
2. Check voltage between front air control harness connector M49 (A) terminal 15 and connector M50 (B) terminal 27, and ground.

Terminals		Ignition switch position			
(+)		(-)	OFF	ACC	ON
Front air control connector	Terminal No.				
M49 (A)	15	Ground	Approx. 0V	Approx. 0V	Battery voltage
M50 (B)	27		Battery voltage	Battery voltage	Battery voltage

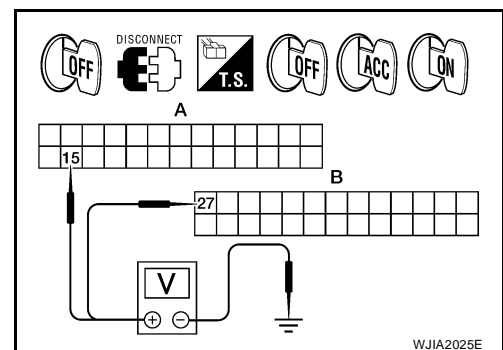

OK or NG

OK >> GO TO 2.

NG >> Check 10A and 15A fuses [Nos. 2 and 19, located in the fuse block (J/B)]. Refer to [PG-84](#).

- If fuses are OK, check harness for open circuit. Repair or replace as necessary.
- If fuses are NG, replace fuse and check harness for short circuit. Repair or replace as necessary.

TROUBLE DIAGNOSIS

2. CHECK GROUND CIRCUIT FOR FRONT AIR CONTROL

1. Turn ignition switch OFF.
2. Check continuity between front air control harness connector M50 terminal 36 and ground.

Continuity should exist.

OK or NG

- OK >> Replace front air control. Refer to [ATC-160, "FRONT AIR CONTROL"](#).
- NG >> Repair harness or connector.

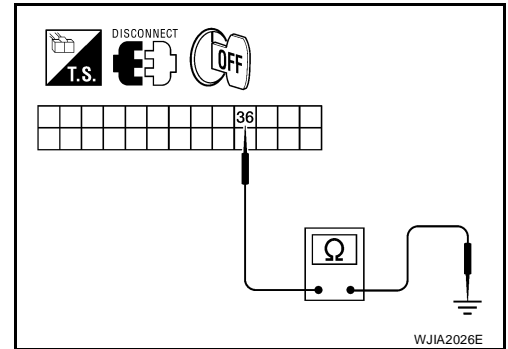

A
B
C
D
E
F
G
H
I

ATC

K
L
M

TROUBLE DIAGNOSIS

EJS004K2

Mode Door Motor Circuit

SYMPTOM:



- Air outlet does not change.
- Mode door motor does not operate normally.

INSPECTION FLOW

1. CONFIRM SYMPTOM BY PERFORMING OPERATIONAL CHECK - DISCHARGE AIR

1. Press each of the four mode position switches and then press the  (DEF) switch. Each position indicator should change shape (on display).
2. Confirm that discharge air comes out according to the air distribution table. Refer to [ATC-29, "Discharge Air Flow"](#).

NOTE:

Confirm that the compressor clutch is engaged (visual inspection) and intake door position is at FRESH when DEF () or D/F () is selected.

Can a symptom be duplicated?

- YES >> GO TO 3.
NO >> GO TO 2.

2. PERFORM COMPLETE OPERATIONAL CHECK

Perform a complete operational check and check for any symptoms. Refer to [ATC-55, "Operational Check \(Front\)"](#).

Can a symptom be duplicated?

- YES >> Refer to [ATC-36, "SYMPTOM TABLE"](#).
NO >> System OK.

3. CHECK FOR SERVICE BULLETINS

Check for any service bulletins.

>> GO TO 4.

4. CHECK MODE DOOR OPERATION

Check and verify mode door mechanism for smooth operation in each mode.

OK or NG

- OK >> GO TO 5.
NG >> Repair as necessary.

5. PERFORM SELF-DIAGNOSIS

Perform self-diagnosis to check for any codes. Refer to [ATC-53, "A/C System Self-diagnosis Function"](#).

Are any self-diagnosis codes present?

- YES >> Refer to [ATC-54, "SELF-DIAGNOSIS CODE CHART"](#).
NO >> GO TO 6.

6. CHECK THE MODE DOOR MOTOR PBR CIRCUIT

Perform diagnostic procedure for the mode door motor. Refer to [ATC-65, "DIAGNOSTIC PROCEDURE FOR MODE DOOR MOTOR"](#).

OK or NG

- OK >> GO TO 7.
NG >> Repair PBR circuit or replace motor.

TROUBLE DIAGNOSIS

7. RECHECK FOR CODES

Perform self-diagnosis. Refer to [ATC-53, "A/C System Self-diagnosis Function"](#) .

Are any self-diagnostic codes present?

YES >> Refer to [ATC-54, "SELF-DIAGNOSIS CODE CHART"](#) .

NO >> GO TO 8.

8. RECHECK FOR SYMPTOMS

Perform a complete operational check and check for any symptoms. Refer to [ATC-55, "Operational Check \(Front\)"](#) .

Does another symptom exist?

YES >> Repair as necessary.

NO >> Replace front air control. Refer to [ATC-160, "FRONT AIR CONTROL"](#) .

A

B

C

D

E

F

G

H

I

ATC

K

L

M

TROUBLE DIAGNOSIS

SYSTEM DESCRIPTION

Component Parts

Mode door control system components are:

- Front air control
- Mode door motor
- PBR (built into mode door motor)
- In-vehicle sensor
- Ambient sensor
- Optical sensor
- Intake sensor

System Operation

The mode door position (vent, B/L, foot, and defrost) is set by the front air control by means of the mode door motor. When a mode door position is selected on the front air control, voltage is applied to one circuit of the mode door motor while ground is applied to the other circuit, causing the mode door motor to rotate. The direction of rotation is determined by which circuit has voltage applied to it, and which one has ground applied to it. The front air control monitors the mode door position by measuring the voltage signal on the PBR circuit.

In AUTO mode the mode door position is set by the front air control which determines the proper position based on inputs from the in-vehicle sensor, ambient sensor, optical sensor, intake sensor, and the temperature selected by the driver or passenger.

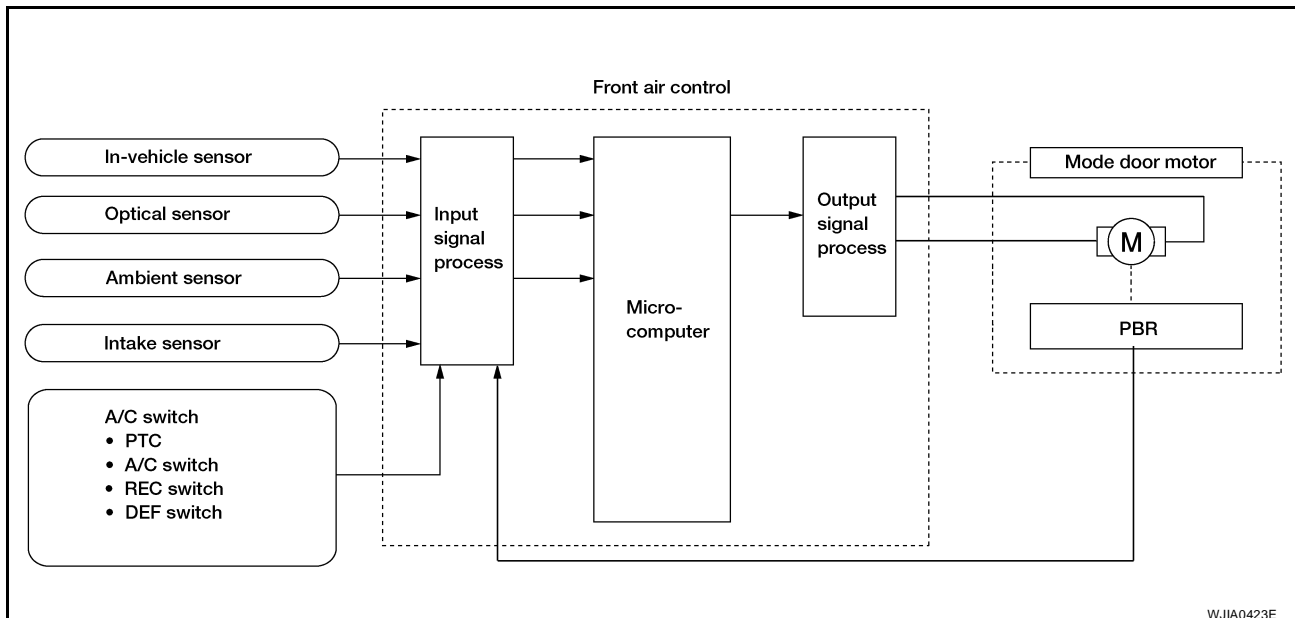

Mode Door Control Specification

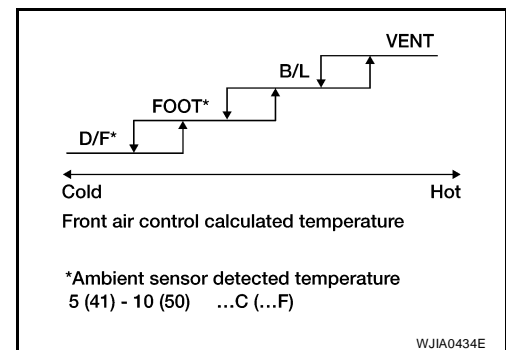

TROUBLE DIAGNOSIS

COMPONENT DESCRIPTION

Mode Door Motor

The mode door motor is attached to the heater & cooling unit assembly. It rotates so that air is discharged from the outlet as indicated by the front air control. Motor rotation is conveyed to a link which activates the mode door.

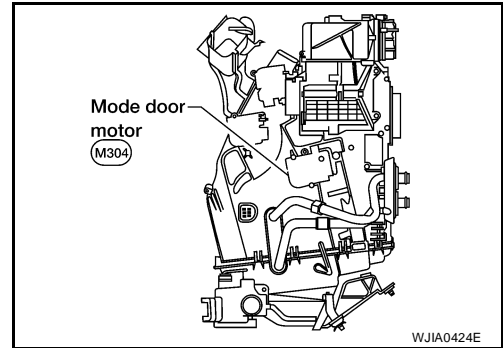

DIAGNOSTIC PROCEDURE FOR MODE DOOR MOTOR

1. CHECK FRONT AIR CONTROL FOR POWER AND GROUND

1. Turn ignition switch ON.
2. Press the B/L (↺) mode switch.
3. Check voltage between front air control harness connector M49 terminal 20 and terminal 19 while pressing the floor (↵) mode switch.

Connector	Terminals		Condition	Voltage (Approx.)
	(+)	(-)		
Front air control: M49	19	20	Press floor mode switch	Battery voltage

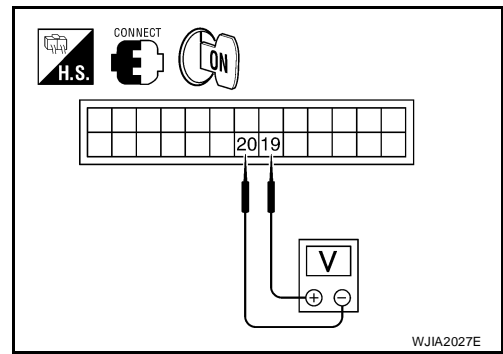

OK or NG

- OK >> GO TO 3.
 NG >> GO TO 2.

2. CHECK MODE DOOR MOTOR CIRCUITS FOR SHORT TO GROUND

1. Turn ignition switch OFF.
2. Disconnect the front air control harness connector.
3. Check resistance between front air control harness connector M49 terminal 20, 19 and ground.

- 20 - Ground : Continuity should not exist.**
19 - Ground : Continuity should not exist.

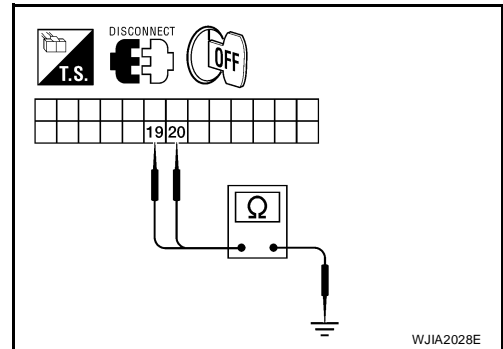

OK or NG

- OK >> Replace front air control. Refer to [ATC-160, "FRONT AIR CONTROL"](#).
 NG >> Repair or replace harness as necessary.



TROUBLE DIAGNOSIS

3. CHECK FRONT AIR CONTROL FOR GROUND AND POWER

1. Press the mode switch to the D/F () mode.
2. Check voltage between front air control harness connector M49 terminal 19 and terminal 20 while pressing the mode switch to the vent () mode.

Connector	Terminals		Condition	Voltage (Approx.)
	(+)	(-)		
Front air control: M49	20	19	Press vent mode switch	Battery voltage

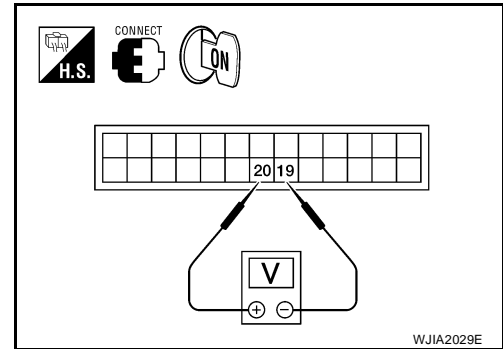

OK or NG

- OK >> GO TO 4.
 NG >> Replace front air control. Refer to [ATC-160, "FRONT AIR CONTROL"](#).

4. CHECK MODE DOOR MOTOR AND CIRCUITS FOR OPEN

1. Turn ignition switch OFF.
2. Disconnect the front air control harness connector.
3. Check continuity between front air control harness connector M49 terminal 20 and terminal 19.

Continuity should exist.

OK or NG

- OK >> GO TO 6.
 NG >> GO TO 5.

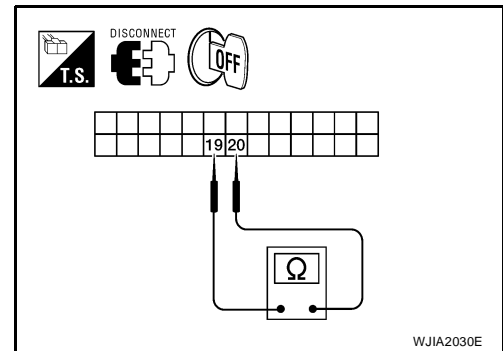

5. CHECK MODE DOOR MOTOR CIRCUITS FOR OPEN

1. Disconnect the mode door motor harness connector.
2. Check continuity between front air control harness connector M49 (A) terminal 20, 19 and the mode door motor harness connector (B) terminal 5, 6.

20 - 5 : Continuity should exist.

19 - 6 : Continuity should exist.

OK or NG

- OK >> Replace mode door motor. Refer to [ATC-180, "MODE DOOR MOTOR"](#).
 NG >> Repair or replace harness as necessary.

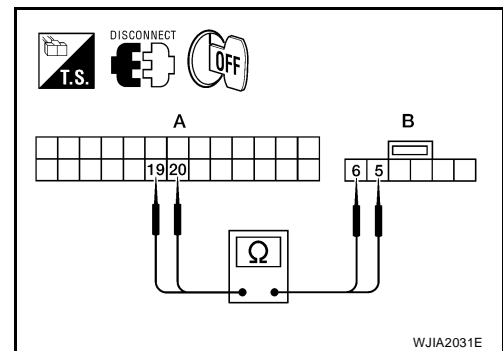

TROUBLE DIAGNOSIS

6. CHECK FRONT AIR CONTROL FOR PBR POWER AND GROUND

1. Reconnect front air control harness connector.
2. Turn ignition switch ON.
3. Check voltage between front air control harness connector M49 (A) terminal 3 and front air control harness connector M50 (B) terminal 28.

Connector	Terminals		Voltage (Approx.)
	(+)	(-)	
Front air control: M49/M50	28 (M50)	3 (M49)	5V

OK or NG

- OK >> GO TO 8.
 NG >> GO TO 7.

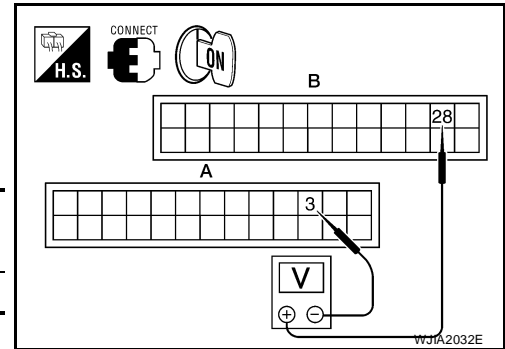

7. CHECK PBR REFERENCE VOLTAGE CIRCUIT FOR SHORT TO GROUND

1. Turn ignition switch OFF.
2. Disconnect the front air control harness connector.
3. Check continuity between front air control harness connector M49 terminal 28 and ground.

Continuity should not exist.

OK or NG

- OK >> Replace front air control. Refer to [ATC-160, "FRONT AIR CONTROL"](#) .
 NG >> Repair or replace harness as necessary.

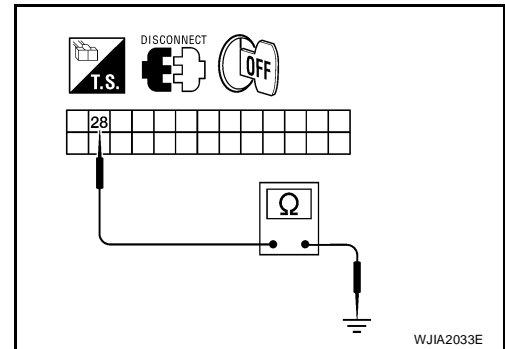

8. CHECK PBR REFERENCE VOLTAGE AND GROUND CIRCUITS

1. Turn ignition switch OFF.
2. Disconnect the front air control harness connector.
3. Check continuity between front air control harness connector M50 (B) terminal 28 and front air control harness connector M49 (A) terminal 3.

Continuity should exist.

OK or NG

- OK >> GO TO 10.
 NG >> GO TO 9.

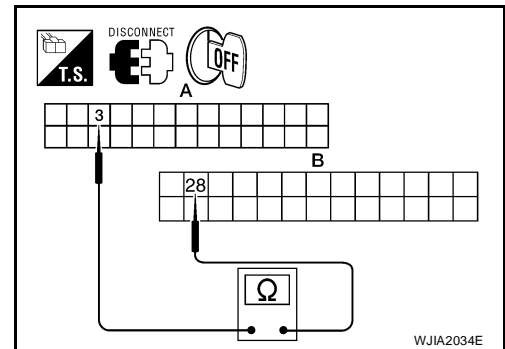

A
B
C
D
E
F
G
H
I
K
L
M

ATC

TROUBLE DIAGNOSIS

9. CHECK PBR REFERENCE VOLTAGE CIRCUIT FOR OPEN

1. Disconnect the mode door motor harness connector.
2. Check continuity between mode door motor harness connector M304 (B) terminal 3 and front air control harness connector M50 (C) terminal 28.

28 - 3 : Continuity should exist.

3. Check continuity between mode door motor harness connector M304 (B) terminal 1 and front air control harness connector M49 (A) terminal 3.

3 - 1 : Continuity should exist.

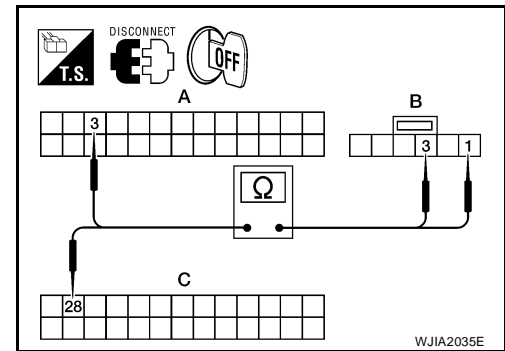

OK or NG

- OK >> Replace mode door motor. Refer to [ATC-180, "MODE DOOR MOTOR"](#).
- NG >> Repair or replace harness as necessary.

10. CHECK PBR FEEDBACK VOLTAGE

1. Reconnect the front air control harness connector.
2. Turn ignition switch ON.
3. Check voltage between front air control harness connector M49 terminal 7 and ground while cycling mode switch through all modes.

Voltage : Approx. 0 - 5V

OK or NG

- OK >> GO TO 12.
- NG >> GO TO 11.

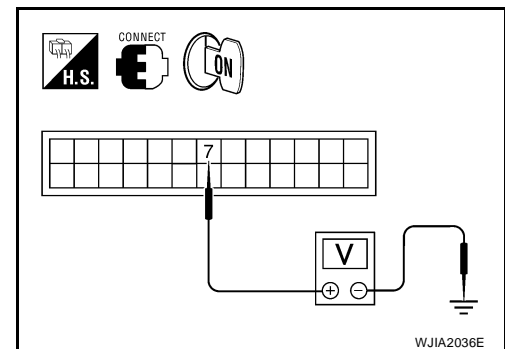

11. CHECK PBR FEEDBACK SIGNAL CIRCUIT FOR SHORT TO GROUND

1. Turn ignition switch OFF.
2. Disconnect front air control harness connector.
3. Check continuity between front air control harness connector M49 terminal 7 and ground.

Continuity should not exist.

OK or NG

- OK >> Replace front air control. Refer to [ATC-160, "FRONT AIR CONTROL"](#).
- NG >> Repair or replace harness as necessary.

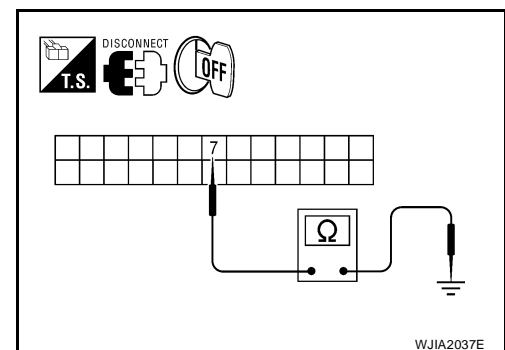

TROUBLE DIAGNOSIS

12. CHECK PBR FEEDBACK CIRCUIT FOR OPEN

1. Turn ignition switch OFF.
2. Disconnect the mode door motor harness connector and front air control harness connector.
3. Check continuity between mode door motor harness connector M304 (B) terminal 2 and front air control harness connector M49 (A) terminal 7.

Continuity should exist.

OK or NG

- OK >> Replace mode door motor. Refer to [ATC-180, "MODE DOOR MOTOR"](#).
- NG >> Repair or replace harness as necessary.

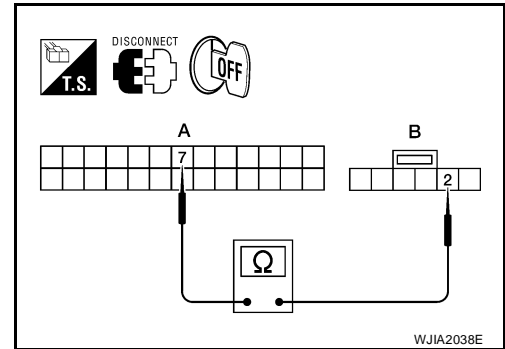

A
B
C
D
E
F
G
H
I
K
L
M

ATC

TROUBLE DIAGNOSIS

EJS004K3

Air Mix Door Motor Circuit

SYMPTOM:

- Discharge air temperature does not change.
- Air mix door motor does not operate.

INSPECTION FLOW

1. CONFIRM SYMPTOM BY PERFORMING OPERATIONAL CHECK - TEMPERATURE INCREASE

1. Turn the temperature control dial (driver) clockwise until 32°C (90°F) is displayed.
2. Check for hot air at discharge air outlets.

>> GO TO 2.

2. CONFIRM SYMPTOM BY PERFORMING OPERATIONAL CHECK - TEMPERATURE DECREASE

1. Turn the temperature control dial (driver) counterclockwise until 16°C (60°F) is displayed.
2. Check for cold air at discharge air outlets.

Can a symptom be duplicated?

YES >> GO TO 4.

NO >> GO TO 3.

3. PERFORM COMPLETE OPERATIONAL CHECK

Perform a complete operational check and check for any symptoms. Refer to [ATC-55, "Operational Check \(Front\)"](#).

Can a symptom be duplicated?

YES >> Refer to [ATC-36, "SYMPTOM TABLE"](#).

NO >> System OK.

4. CHECK FOR SERVICE BULLETINS

Check for any service bulletins.

>> GO TO 5.

5. CHECK AIR MIX DOOR OPERATION

Check and verify air mix door mechanism for smooth operation from 16°C (60°F) to 32°C (90°F) in each mode.

OK or NG

OK >> GO TO 6.

NG >> Repair as necessary.

6. PERFORM SELF-DIAGNOSIS

Perform self-diagnosis to check for any codes. Refer to [ATC-53, "A/C System Self-diagnosis Function"](#).

Are any self-diagnosis codes present?

YES >> Refer to [ATC-54, "SELF-DIAGNOSIS CODE CHART"](#).

NO >> GO TO 7.

7. CHECK THE AIR MIX DOOR MOTOR PBR CIRCUIT

Perform diagnostic procedure for the air mix door motors. Refer to [ATC-70, "Air Mix Door Motor Circuit"](#).

OK or NG

OK >> GO TO 8.

NG >> Repair PBR circuit or replace air mix door motor. Refer to [ATC-182, "AIR MIX DOOR MOTOR"](#).

TROUBLE DIAGNOSIS

8. RECHECK FOR CODES

Perform self-diagnosis. Refer to [ATC-53, "A/C System Self-diagnosis Function"](#) .

Are any self-diagnostic codes present?

YES >> Refer to [ATC-54, "SELF-DIAGNOSIS CODE CHART"](#) .

NO >> GO TO 9.

9. RECHECK FOR ANY SYMPTOMS

Perform a complete operational check for any symptoms. Refer to [ATC-55, "Operational Check \(Front\)"](#) .

Does another symptom exist?

YES >> Refer to [ATC-36, "SYMPTOM TABLE"](#) .

NO >> Replace front air control. Refer to [ATC-160, "FRONT AIR CONTROL"](#) .

A

B

C

D

E

F

G

H

I

ATC

K

L

M

TROUBLE DIAGNOSIS

SYSTEM DESCRIPTION

Component Parts

Air mix door control system components are:

- Front air control
- Air mix door motors (driver, passenger, and rear)
- PBR (built-into air mix door motors)
- In-vehicle sensor
- Ambient sensor
- Optical sensor
- Intake sensor

System Operation

The front air control receives data base on the temperature selected by the driver and front and rear passengers. The front air control then applies a voltage to one circuit of the appropriate air mix door motor, while ground is applied to the other circuit, causing the appropriate air mix door motor to rotate. The direction of rotation is determined by which circuit has voltage applied to it, and which one has ground applied to it. The front air control monitors the air mix door positions by measuring the voltage signal on the PBR circuits of each door.

In AUTO mode the air mix, intake, mode door, and defrost door positions are set by the front air control which determines the proper position based on inputs from the in-vehicle sensor, ambient sensor, optical sensor, intake sensor, and the temperature selected by the driver and front and rear passengers.

Subsequently, HOT/COLD or DEFROST/VENT or FRESH/RECIRCULATION operation is selected. The new door position data is returned to the front air control.

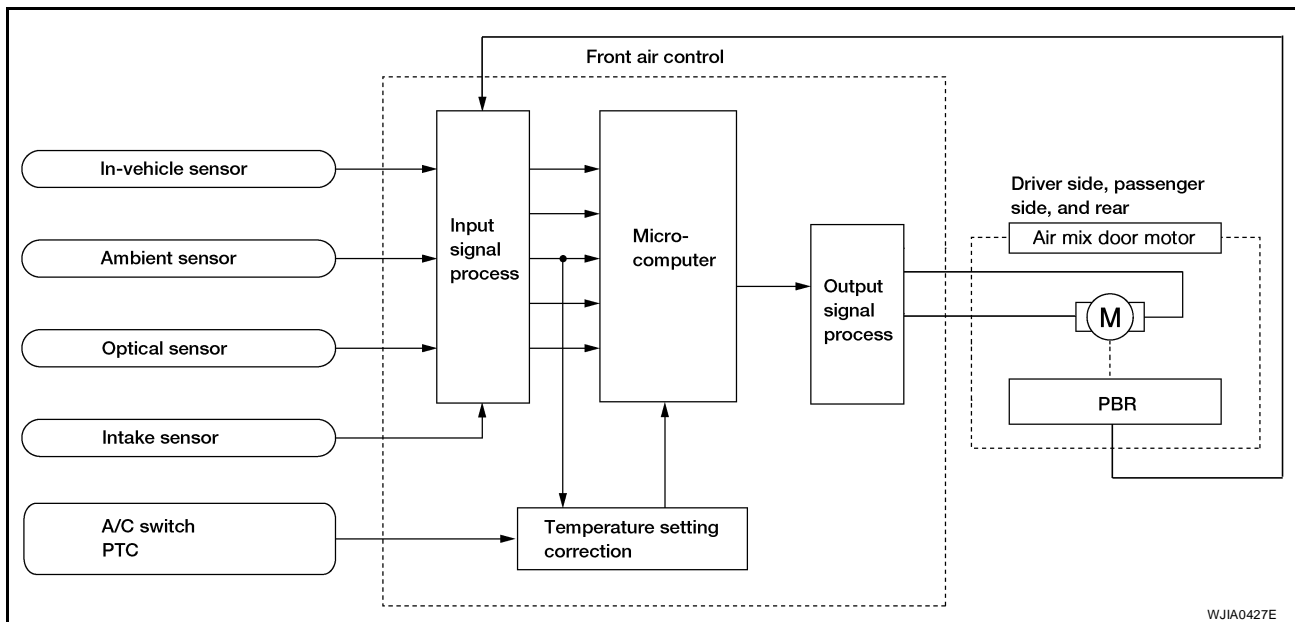

Air Mix Door Control Specification

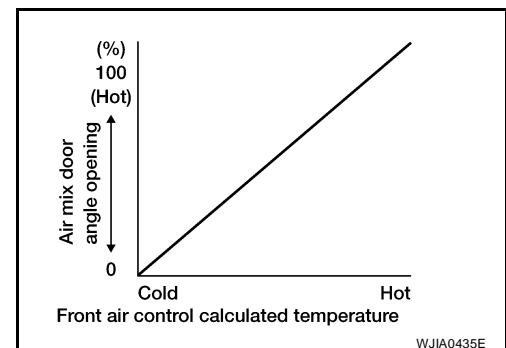

TROUBLE DIAGNOSIS

COMPONENT DESCRIPTION

Air Mix Door Motors

The driver and front passenger air mix door motors are attached to the front heater & cooling unit assembly. The rear air mix door motor is attached to the rear heater & cooling unit assembly. These motors rotate so that the air mix door is opened or closed to a position set by the front (or rear) air control. Motor rotation is then conveyed through a shaft and the air mix door position is then fed back to the front air control by the PBR built into the air mix door motors.

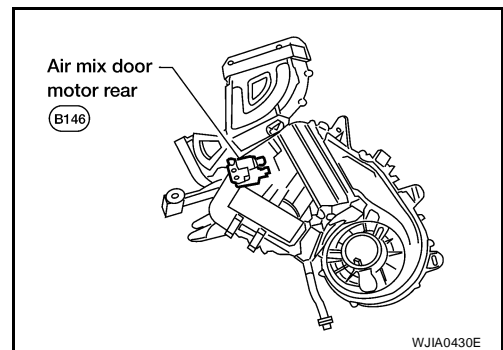
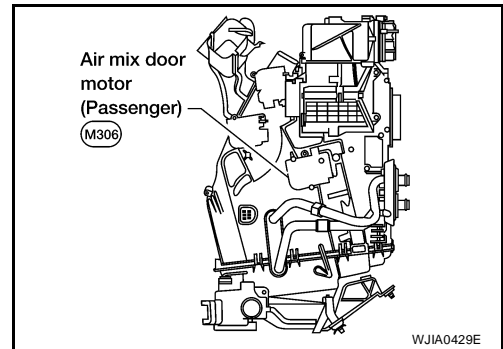
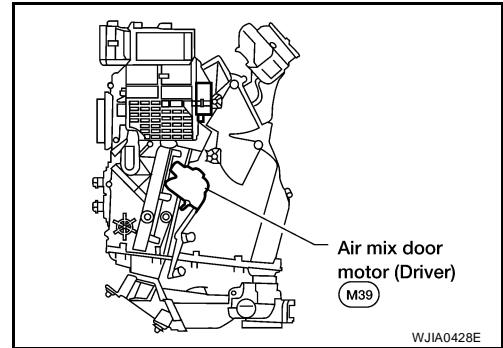

DIAGNOSTIC PROCEDURE FOR AIR MIX DOOR MOTOR (DRIVER)

1. CHECK FRONT AIR CONTROL FOR POWER AND GROUND

1. Turn ignition switch ON.
2. Rotate temperature control dial (driver) to 32°C (90°F).
3. Check voltage between front air control harness connector M49 terminal 18 and terminal 17 while rotating temperature control dial (driver) to 16°C (60°F).

Connector	Terminals		Condition	Voltage (Approx.)
	(+)	(-)		
Front air control: M49	18	17	Rotate temp control dial	Battery voltage

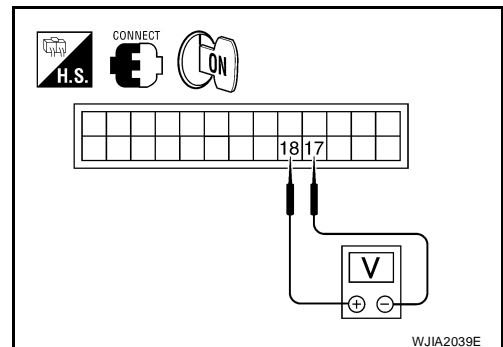

OK or NG

- OK >> GO TO 3.
NG >> GO TO 2.

A
B
C
D
E
F
G
H
I
ATC
K
L
M

TROUBLE DIAGNOSIS

2. CHECK AIR MIX DOOR MOTOR (DRIVER) CIRCUITS FOR SHORT TO GROUND

1. Turn ignition switch OFF.
2. Disconnect the front air control harness connector.
3. Check continuity between front air control harness connector M49 terminal 18, 17 and ground.

18 - Ground : Continuity should not exist.
17 - Ground : Continuity should not exist.

OK or NG

- OK >> Replace front air control. Refer to [ATC-160, "FRONT AIR CONTROL"](#).
 NG >> Repair or replace harness as necessary.

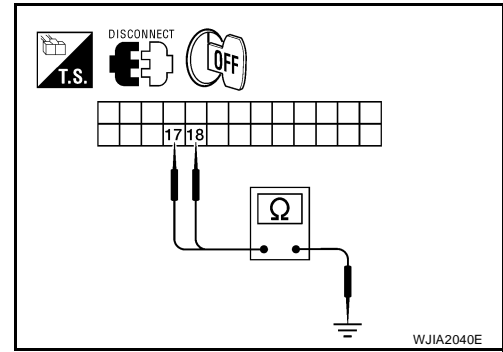

3. CHECK FRONT AIR CONTROL FOR POWER AND GROUND

1. Turn ignition switch ON.
2. Rotate temperature control dial (driver) to 16°C (60°F).
3. Check voltage between front air control harness connector M49 terminal 18 and terminal 17 while rotating temperature control dial (driver) to 32°C (90°F).

Connector	Terminals		Condition	Voltage (Approx.)
	(+)	(-)		
Front air control: M49	17	18	Rotate temp control dial	Battery voltage

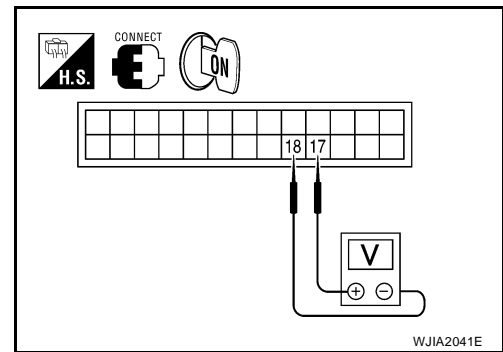

OK or NG

- OK >> GO TO 4.
 NG >> Replace front air control. Refer to [ATC-160, "FRONT AIR CONTROL"](#).

4. CHECK AIR MIX DOOR MOTOR (DRIVER) CIRCUITS FOR OPEN

1. Turn ignition switch OFF.
2. Disconnect the front air control harness connector.
3. Check continuity between front air control harness connector M49 terminal 18 and terminal 17.

Continuity should exist.

OK or NG

- OK >> GO TO 6.
 NG >> GO TO 5.

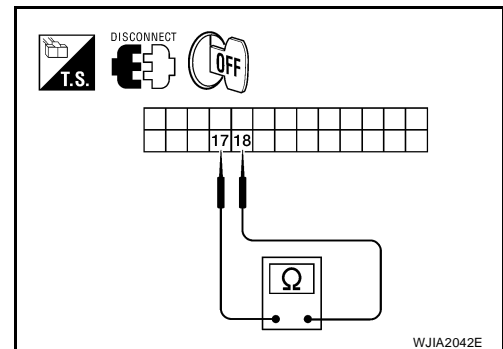

TROUBLE DIAGNOSIS

5. CHECK AIR MIX DOOR MOTOR (DRIVER) CIRCUITS FOR OPEN

1. Disconnect the air mix door motor (driver) harness connector.
2. Check continuity between front air control harness connector M49 (A) terminal 18, 17 and the air mix door motor (driver) harness connector M39 (B) terminal 5, 6.

18 - 5 : Continuity should exist.
17 - 6 : Continuity should exist.

OK or NG

- OK >> Replace air mix door motor (driver). Refer to [ATC-183, "FRONT AIR MIX DOOR MOTOR \(DRIVER\)"](#).
- NG >> Repair or replace harness as necessary.

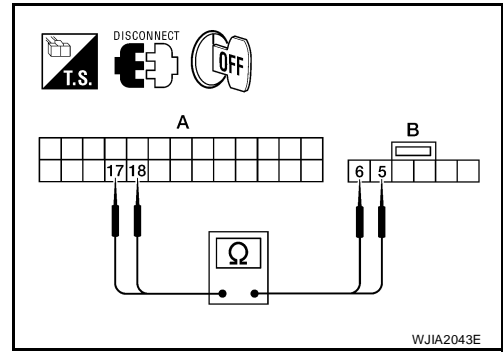

6. CHECK FRONT AIR CONTROL FOR PBR POWER AND GROUND

1. Reconnect front air control harness connector.
2. Turn ignition switch ON.
3. Check voltage between front air control harness connector M50 (B) terminal 28 and front air control harness connector M49 (A) terminal 3.

Connectors	Terminals		Voltage (Approx.)
	(+)	(-)	
Front air control: M49/M50	28 (50)	3 (M49)	5V

OK or NG

- OK >> GO TO 8.
 NG >> GO TO 7.

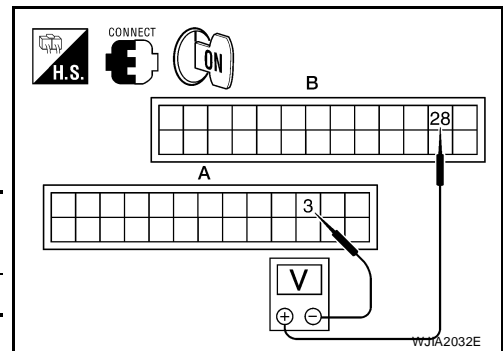

7. CHECK PBR REFERENCE VOLTAGE CIRCUIT FOR SHORT TO GROUND

1. Turn ignition switch OFF.
2. Disconnect the front air control harness connector.
3. Check continuity between front air control harness connector M50 terminal 28 and ground.

Continuity should not exist.

OK or NG

- OK >> Replace front air control. Refer to [ATC-160, "FRONT AIR CONTROL"](#).
- NG >> Repair or replace harness as necessary.

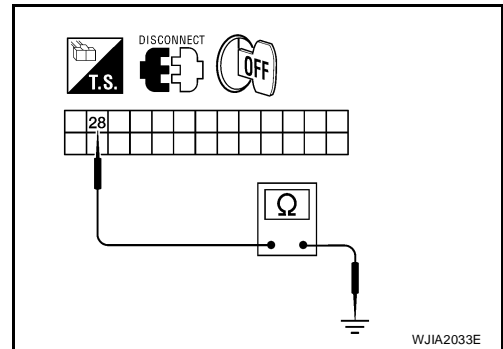

8. CHECK PBR REFERENCE VOLTAGE AND GROUND CIRCUITS

1. Turn ignition switch OFF.
2. Disconnect the front air control harness connector.
3. Check continuity between front air control harness connector M50 (B) terminal 28 and front air control harness connector M49 (A) terminal 3.

Continuity should exist.

OK or NG

- OK >> GO TO 10.
 NG >> GO TO 9.

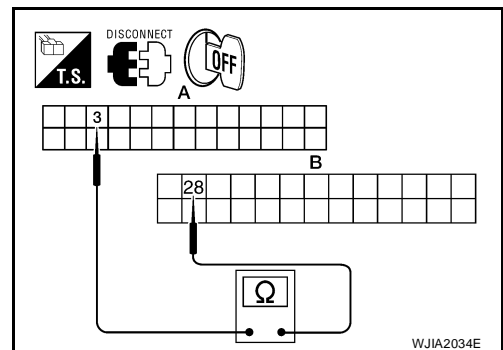

TROUBLE DIAGNOSIS

9. CHECK PBR REFERENCE VOLTAGE CIRCUIT FOR OPEN

1. Disconnect the air mix door motor (driver) harness connector.
2. Check continuity between air mix door motor (driver) harness connector M39 (B) terminal 3 and front air control harness connector M50 (C) terminal 28.

28 - 3 : Continuity should exist.

3. Check continuity between air mix door motor (driver) harness connector M39 (B) terminal 1 and front air control harness connector M49 (A) terminal 3.

3 - 1 : Continuity should exist.

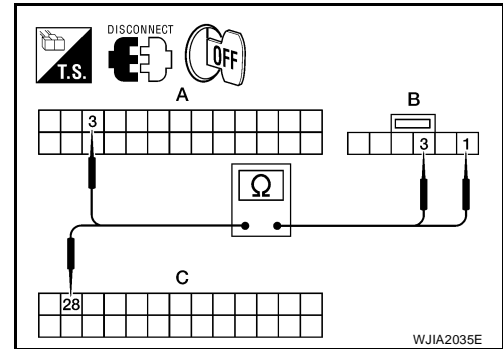

OK or NG

- OK >> Replace air mix door motor (driver). Refer to [ATC-183, "FRONT AIR MIX DOOR MOTOR \(DRIVER\)"](#).
- NG >> Repair or replace harness as necessary.

10. CHECK PBR FEEDBACK VOLTAGE

1. Reconnect the front air control harness connector.
2. Turn ignition switch ON.
3. Check voltage between front air control harness connector M49 terminal 6 and ground while rotating temperature control dial from 32°C (90°F) to 16°C (60°F).

Voltage : Approx. 0 - 5V

OK or NG

- OK >> GO TO 12.
- NG >> GO TO 11.

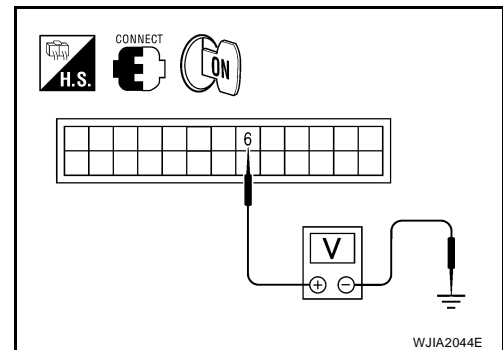

11. CHECK PBR FEEDBACK SIGNAL CIRCUIT FOR SHORT TO GROUND

1. Turn ignition switch OFF.
2. Disconnect front air control harness connector.
3. Check continuity between front air control harness connector M49 terminal 6 and ground.

Continuity should not exist.

OK or NG

- OK >> Replace front air control. Refer to [ATC-160, "FRONT AIR CONTROL"](#).
- NG >> Repair or replace harness as necessary.

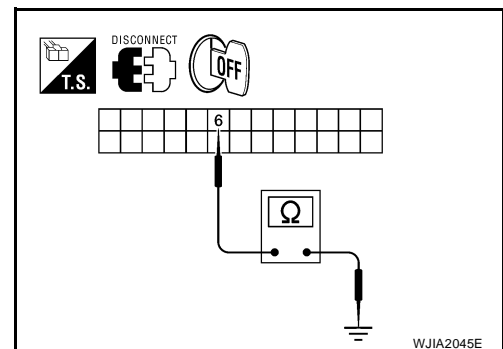

TROUBLE DIAGNOSIS

12. CHECK PBR FEEDBACK CIRCUIT FOR OPEN

1. Turn ignition switch OFF.
2. Disconnect the air mix door motor (driver) harness connector and front air control harness connector.
3. Check continuity between air mix door motor (driver) harness connector M39 (B) terminal 2 and front air control harness connector M49 (A) terminal 6.

Continuity should exist.

OK or NG

- OK >> Replace air mix door motor (driver). Refer to [ATC-183, "FRONT AIR MIX DOOR MOTOR \(DRIVER\)"](#).
- NG >> Repair or replace harness as necessary.

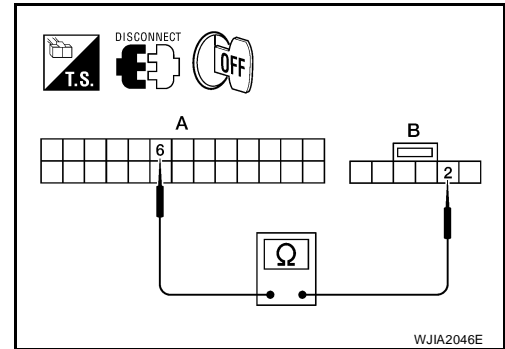

DIAGNOSTIC PROCEDURE FOR AIR MIX DOOR MOTOR (PASSENGER)

1. CHECK FRONT AIR CONTROL FOR POWER AND GROUND

1. Turn ignition switch ON.
2. Rotate temperature control dial (passenger) to 32°C (90°F).
3. Check voltage between front air control harness connector M49 terminal 2 and terminal 14 while rotating temperature control dial (passenger) to 16°C (60°F).

Connector	Terminals		Condition	Voltage (Approx.)
	(+)	(-)		
Front air control: M49	14	2	Rotate temp control dial	Battery voltage

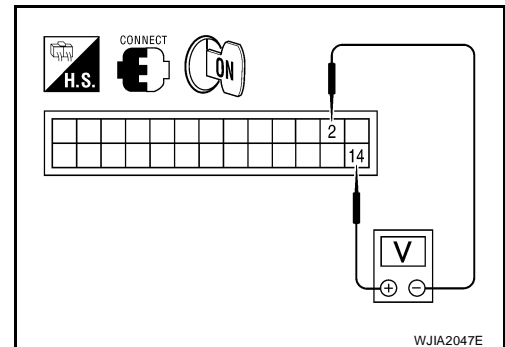

OK or NG

- OK >> GO TO 3.
- NG >> GO TO 2.

2. CHECK AIR MIX DOOR MOTOR (PASSENGER) CIRCUITS FOR SHORT TO GROUND

1. Turn ignition switch OFF.
2. Disconnect the front air control harness connector.
3. Check continuity between front air control harness connector M49 terminal 2, 14 and ground.

2 - Ground : Continuity should not exist.

14 - Ground : Continuity should not exist.

OK or NG

- OK >> Replace front air control. Refer to [ATC-160, "FRONT AIR CONTROL"](#).
- NG >> Repair or replace harness as necessary.

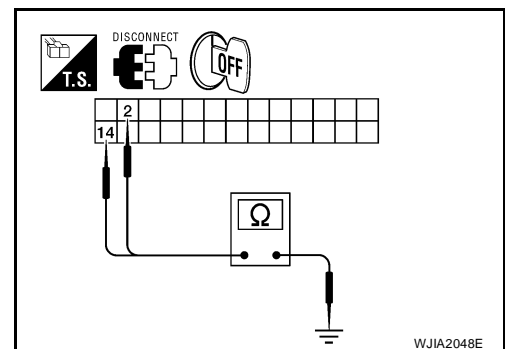

TROUBLE DIAGNOSIS

3. CHECK FRONT AIR CONTROL FOR POWER AND GROUND

1. Turn ignition switch ON.
2. Rotate temperature control dial (passenger) to 16°C (60°F).
3. Check voltage between front air control harness connector M49 terminal 2 and terminal 14 while rotating temperature control dial (passenger) to 32°C (90°F).

Connector	Terminals		Condition	Voltage (Approx.)
	(+)	(-)		
Front air control: M49	2	14	Rotate temp control dial	Battery voltage

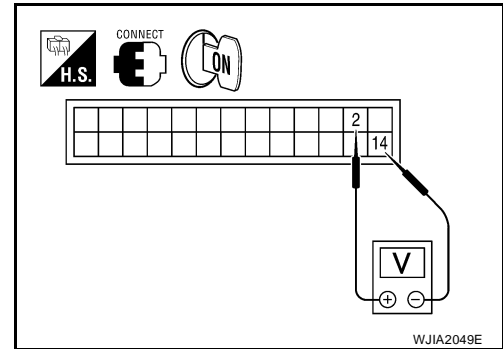

OK or NG

- OK >> GO TO 4.
 NG >> Replace front air control. Refer to [ATC-160, "FRONT AIR CONTROL"](#).

4. CHECK AIR MIX DOOR MOTOR (PASSENGER) CIRCUITS FOR OPEN

1. Turn ignition switch OFF.
2. Disconnect the front air control harness connector.
3. Check continuity between front air control harness connector M49 terminal 2 and terminal 14.

Continuity should exist.

OK or NG

- OK >> GO TO 6.
 NG >> GO TO 5.

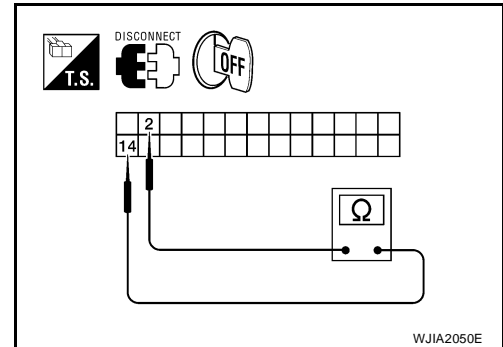

5. CHECK AIR MIX DOOR MOTOR (PASSENGER) CIRCUITS FOR OPEN

1. Disconnect the air mix door motor (passenger) harness connector.
2. Check continuity between front air control harness connector M49 (A) terminal 2, 14 and the air mix door motor (passenger) harness connector M306 (B) terminal 5, 6.

2 - 5 : Continuity should exist.
14 - 6 : Continuity should exist.

OK or NG

- OK >> Replace air mix door motor (passenger). Refer to [ATC-77, "DIAGNOSTIC PROCEDURE FOR AIR MIX DOOR MOTOR \(PASSENGER\)"](#).
 NG >> Repair or replace harness as necessary.

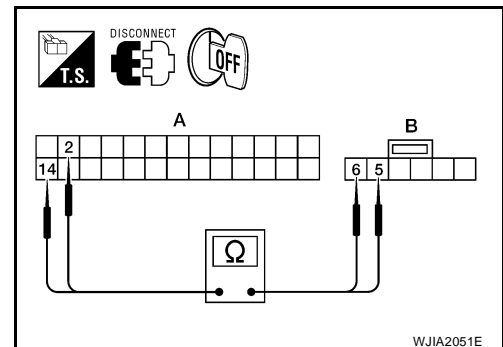

TROUBLE DIAGNOSIS

6. CHECK FRONT AIR CONTROL FOR PBR POWER AND GROUND

1. Reconnect front air control harness connector.
2. Turn ignition switch ON.
3. Check voltage between front air control harness connector M50 (B) terminal 28 and front air control harness connector M49 (A) terminal 3.

Connectors	Terminals		Voltage (Approx.)
	(+)	(-)	
Front air control: M49/M50	28 (M50)	3 (M49)	5V

OK or NG

- OK >> GO TO 8.
 NG >> GO TO 7.

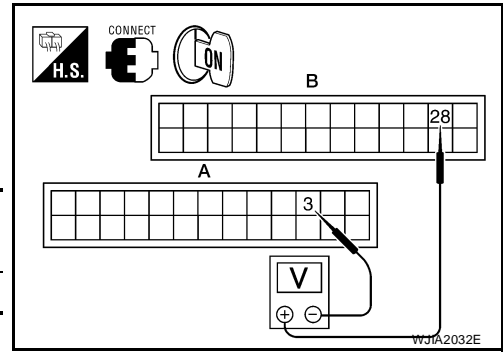

7. CHECK PBR REFERENCE VOLTAGE CIRCUIT FOR SHORT TO GROUND

1. Turn ignition switch OFF.
2. Disconnect the front air control harness connector.
3. Check continuity between front air control harness connector M50 terminal 28 and ground.

Continuity should not exist.

OK or NG

- OK >> Replace front air control. Refer to [ATC-160, "FRONT AIR CONTROL"](#).
 NG >> Repair or replace harness as necessary.

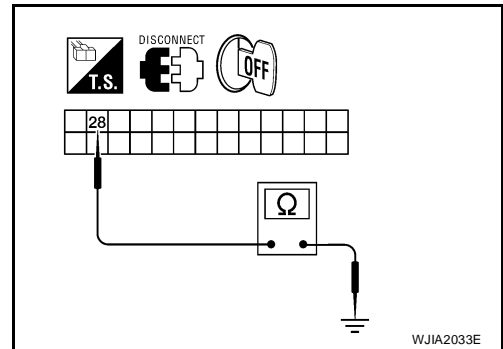

8. CHECK PBR REFERENCE VOLTAGE AND GROUND CIRCUITS

1. Turn ignition switch OFF.
2. Disconnect the front air control harness connector.
3. Check continuity between front air control harness connector M50 (B) terminal 28 and front air control harness connector M49 (A) terminal 3.

Continuity should exist.

OK or NG

- OK >> GO TO 10.
 NG >> GO TO 9.

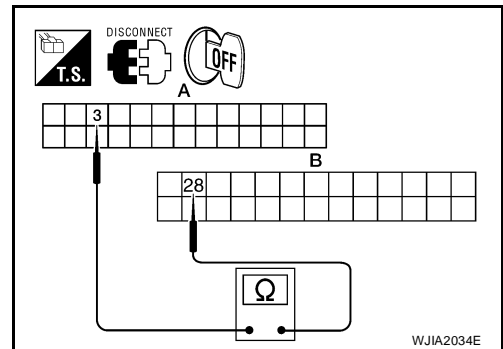

A
B
C
D
E
F
G
H
I
K
L
M

ATC

TROUBLE DIAGNOSIS

9. CHECK PBR REFERENCE VOLTAGE CIRCUIT FOR OPEN

1. Disconnect the air mix door motor (passenger) harness connector.
2. Check continuity between air mix door motor (passenger) harness connector M306 (B) terminal 3 and front air control harness connector M50 (C) terminal 28.

28 - 3 : Continuity should exist.

3. Check continuity between air mix door motor (passenger) harness connector M306 (B) terminal 1 and front air control harness connector M49 (A) terminal 3.

3 - 1 : Continuity should exist.

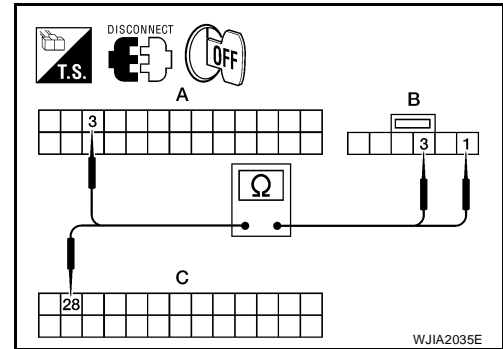

OK or NG

OK >> Replace air mix door motor (passenger). Refer to [ATC-184, "FRONT AIR MIX DOOR MOTOR \(PASSENGER\)"](#).

NG >> Repair or replace harness as necessary.

10. CHECK PBR FEEDBACK VOLTAGE

1. Reconnect the front air control harness connector.
2. Turn ignition switch ON.
3. Check voltage between front air control harness connector M50 terminal 29 and ground while rotating temperature control dial (passenger) from 32°C (90° F) to 16°C (60° F).

Voltage : Approx. 0 - 5V

OK or NG

OK >> GO TO 12.

NG >> GO TO 11.

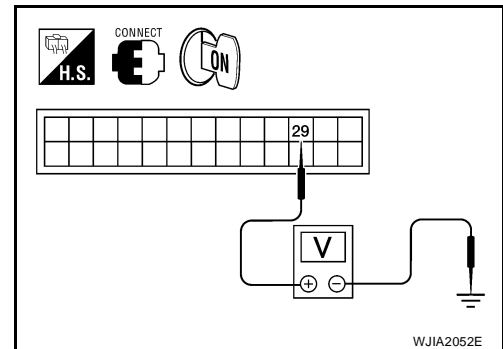

11. CHECK PBR FEEDBACK SIGNAL CIRCUIT FOR SHORT TO GROUND

1. Turn ignition switch OFF.
2. Disconnect front air control harness connector.
3. Check continuity between front air control harness connector M50 terminal 29 and ground.

Continuity should not exist.

OK or NG

OK >> Replace front air control. Refer to [ATC-160, "FRONT AIR CONTROL"](#).

NG >> Repair or replace harness as necessary.

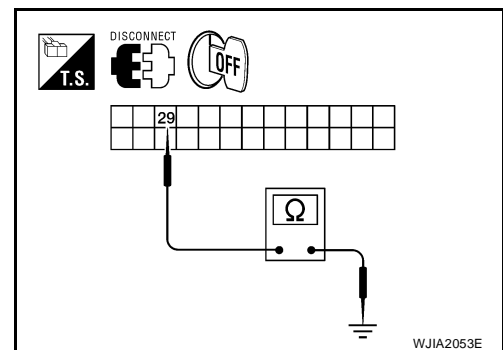

TROUBLE DIAGNOSIS

12. CHECK PBR FEEDBACK CIRCUIT FOR OPEN

1. Turn ignition switch OFF.
2. Disconnect the air mix door motor (passenger) harness connector and front air control harness connector.
3. Check continuity between air mix door motor (passenger) harness connector M306 (B) terminal 2 and front air control harness connector M50 (A) terminal 29.

Continuity should exist.

OK or NG

OK >> Replace air mix door motor (passenger). Refer to [ATC-184, "FRONT AIR MIX DOOR MOTOR \(PASSENGER\)"](#)

NG >> Repair or replace harness as necessary.

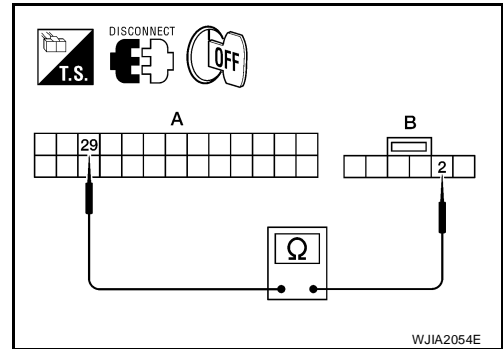

DIAGNOSTIC PROCEDURE FOR AIR MIX DOOR MOTOR (REAR)

1. CHECK FRONT AIR CONTROL FOR POWER AND GROUND

1. Turn ignition switch ON.
2. Rotate temperature control dial (rear) to maximum hot.
3. Check voltage between front air control harness connector M50 terminal 43 and terminal 44 while rotating temperature control dial (rear) to maximum cold.

Connector	Terminals		Condition	Voltage (Approx.)
	(+)	(-)		
Front air control: M50	43	44	Rotate temp control dial	Battery voltage

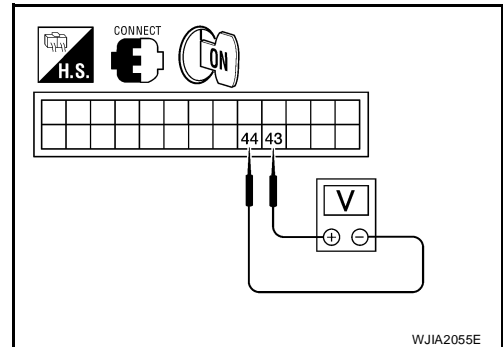

OK or NG

OK >> GO TO 3.

NG >> GO TO 2.

2. CHECK AIR MIX DOOR MOTOR (REAR) CIRCUITS FOR SHORT TO GROUND

1. Turn ignition switch OFF.
2. Disconnect the front air control harness connector.
3. Check continuity between front air control harness connector M50 terminal 43, 44 and ground.

43 - Ground : Continuity should not exist.

44 - Ground : Continuity should not exist.

OK or NG

OK >> Replace front air control. Refer to [ATC-160, "FRONT AIR CONTROL"](#).

NG >> Repair or replace harness as necessary.

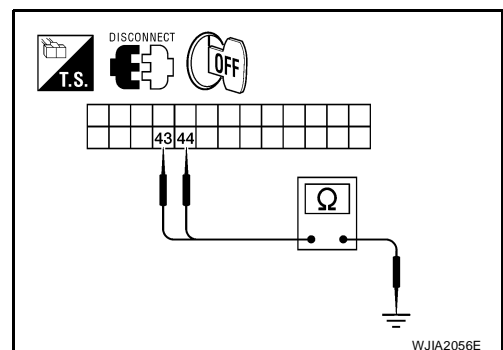

TROUBLE DIAGNOSIS

3. CHECK FRONT AIR CONTROL FOR POWER AND GROUND

1. Turn ignition switch ON.
2. Rotate temperature control dial (rear) to maximum cold.
3. Check voltage between front air control harness connector M50 terminal 43 and terminal 44 while rotating temperature control dial (rear) to maximum hot.

Connector	Terminals		Condition	Voltage (Approx.)
	(+)	(-)		
Front air control: M50	44	43	Rotate temp control dial	Battery voltage

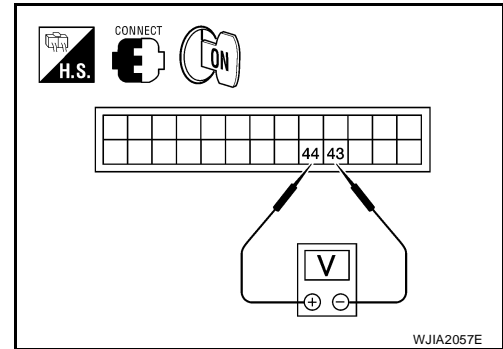

OK or NG

- OK >> GO TO 4.
 NG >> Replace front air control. Refer to [ATC-160, "FRONT AIR CONTROL"](#).

4. CHECK AIR MIX DOOR MOTOR (REAR) CIRCUITS FOR OPEN

1. Turn ignition switch OFF.
2. Disconnect the front air control harness connector.
3. Check continuity between front air control harness connector M50 terminal 43 and terminal 44.

Continuity should exist.

OK or NG

- OK >> GO TO 6.
 NG >> GO TO 5.

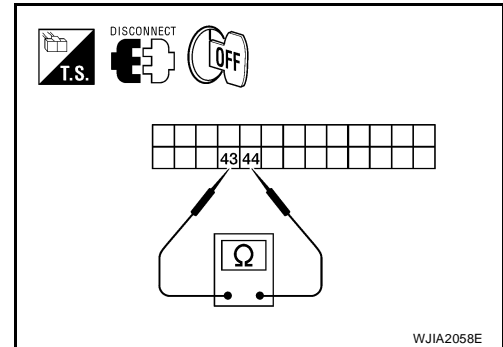

5. CHECK AIR MIX DOOR MOTOR (REAR) CIRCUITS FOR OPEN

1. Disconnect the air mix door motor (rear) harness connector.
2. Check continuity between front air control harness connector M50 (A) terminal 43, 44 and the air mix door motor (rear) harness connector B146 (B) terminal 1, 6.

- 43 - 1 : Continuity should exist.**
44 - 6 : Continuity should exist.

OK or NG

- OK >> Replace air mix door motor (rear). Refer to [ATC-184, "REAR AIR MIX DOOR MOTOR"](#).
 NG >> Repair or replace harness as necessary.

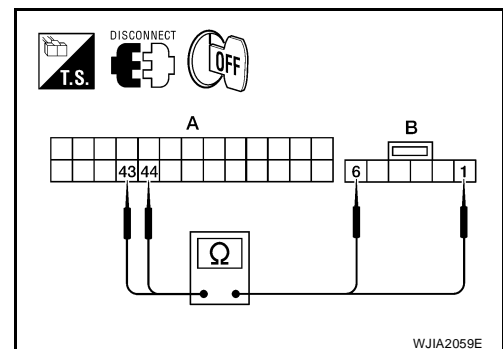

TROUBLE DIAGNOSIS

6. CHECK FRONT AIR CONTROL FOR PBR POWER AND GROUND

1. Reconnect front air control harness connector.
2. Turn ignition switch ON.
3. Check voltage between front air control harness connector M50 (B) terminal 28 and front air control harness connector M49 (A) terminal 3.

Connectors	Terminals		Voltage (Approx.)
	(+)	(-)	
Front air control: M49/M50	28 (M50)	3 (M49)	5V

OK or NG

- OK >> GO TO 8.
 NG >> GO TO 7.

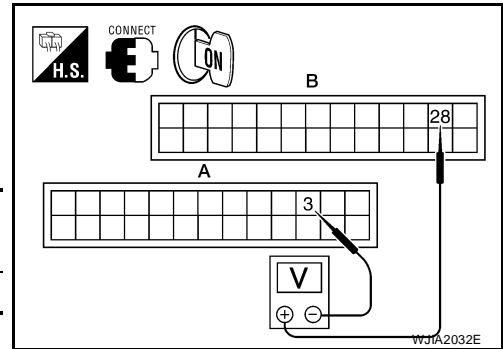

7. CHECK PBR REFERENCE VOLTAGE CIRCUIT FOR SHORT TO GROUND

1. Turn ignition switch OFF.
2. Disconnect the front air control harness connector.
3. Check continuity between front air control harness connector M50 terminal 28 and ground.

Continuity should not exist.

OK or NG

- OK >> Replace front air control. Refer to [ATC-160, "FRONT AIR CONTROL"](#).
 NG >> Repair or replace harness as necessary.

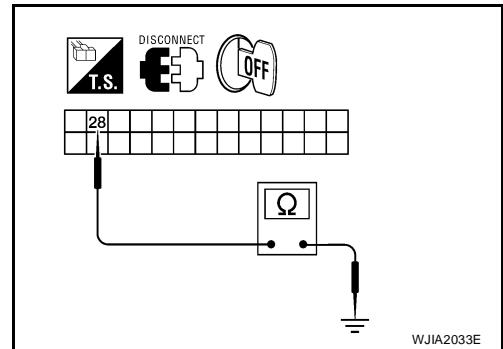

8. CHECK PBR REFERENCE VOLTAGE AND GROUND CIRCUITS

1. Turn ignition switch OFF.
2. Disconnect the front air control harness connector.
3. Check continuity between front air control harness connector M50 (B) terminal 28 and front air control harness connector M49 (A) terminal 3.

Continuity should exist.

OK or NG

- OK >> GO TO 10.
 NG >> GO TO 9.

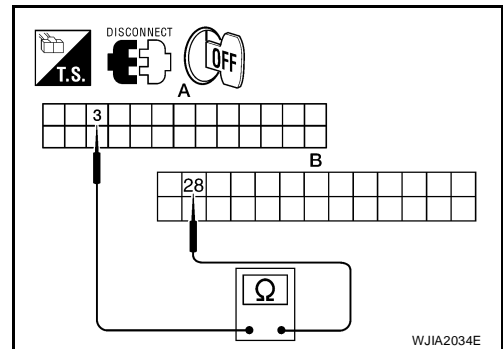

A
B
C
D
E
F
G
H
I
K
L
M

ATC

TROUBLE DIAGNOSIS

9. CHECK PBR REFERENCE VOLTAGE CIRCUIT FOR OPEN

1. Disconnect the air mix door motor (rear) harness connector.
2. Check continuity between air mix door motor (rear) harness connector B146 (B) terminal 3 and front air control harness connector M50 (C) terminal 28.

28 - 3 : Continuity should exist.

3. Check continuity between air mix door motor (rear) harness connector B146 (B) terminal 2 and front air control harness connector M49 (A) terminal 3.

3 - 2 : Continuity should exist.

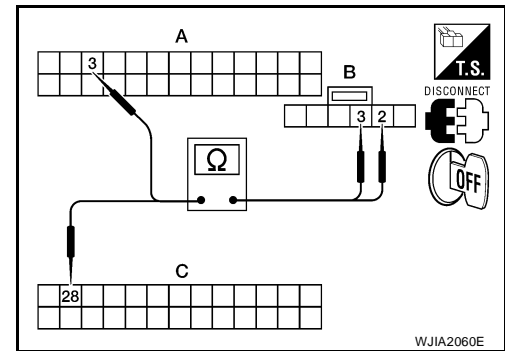

OK or NG

- OK >> Replace air mix door motor (rear). Refer to [ATC-184, "REAR AIR MIX DOOR MOTOR"](#).
- NG >> Repair or replace harness as necessary.

10. CHECK PBR FEEDBACK VOLTAGE

1. Reconnect the front air control harness connector.
2. Turn ignition switch ON.
3. Check voltage between front air control harness connector M50 terminal 30 and ground while rotating temperature control dial (rear) from maximum cold to maximum hot.

Voltage : Approx. 0 - 5V

OK or NG

- OK >> GO TO 12.
- NG >> GO TO 11.

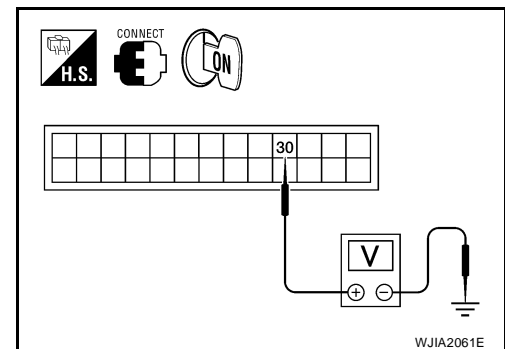

11. CHECK PBR FEEDBACK SIGNAL CIRCUIT FOR SHORT TO GROUND

1. Turn ignition switch OFF.
2. Disconnect front air control harness connector.
3. Check continuity between front air control harness connector M50 terminal 30 and ground.

Continuity should not exist.

OK or NG

- OK >> Replace front air control. Refer to [ATC-160, "FRONT AIR CONTROL"](#).
- NG >> Repair or replace harness as necessary.

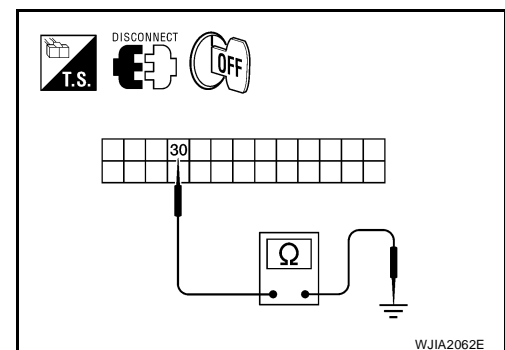

TROUBLE DIAGNOSIS

12. CHECK PBR FEEDBACK CIRCUIT FOR OPEN

1. Turn ignition switch OFF.
2. Disconnect the air mix door motor (rear) harness connector and front air control harness connector.
3. Check continuity between air mix door motor (rear) harness connector B146 (B) terminal 4 and front air control harness connector M50 (A) terminal 30.

Continuity should exist.

OK or NG

- OK >> Replace air mix door motor (rear). Refer to [ATC-184](#), "[REAR AIR MIX DOOR MOTOR](#)".
- NG >> Repair or replace harness as necessary.

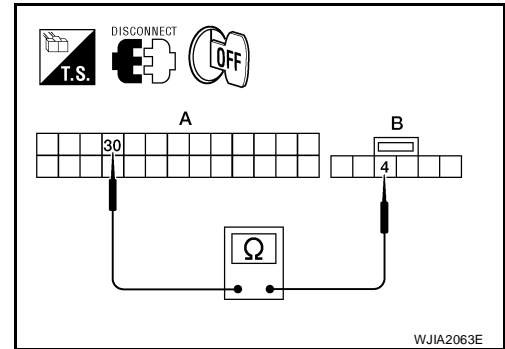

A
B
C
D
E
F
G
H
I
K
L
M

ATC

TROUBLE DIAGNOSIS

EJS004K4





Intake Door Motor Circuit

SYMPTOM:

- Intake door does not change.
- Intake door motor does not operate normally.

INSPECTION FLOW

1. CONFIRM SYMPTOM BY PERFORMING OPERATIONAL CHECK - REC ()

1. Press the vent mode ().
2. Press REC () switch. The REC () indicator should illuminate.
3. Press REC () switch again. The REC () indicator should go out.
4. Listen for intake door position change (you should hear blower sound changes slightly).

Can a symptom be duplicated?

- YES >> GO TO 3.
NO >> GO TO 2.

2. PERFORM COMPLETE OPERATIONAL CHECK

Perform a complete operational check and check for any symptoms. Refer to [ATC-55, "Operational Check \(Front\)"](#) .

Can a symptom be duplicated?

- YES >> Refer to [ATC-36, "SYMPTOM TABLE"](#) .
NO >> System OK.

3. CHECK FOR SERVICE BULLETINS

Check for any service bulletins.

>> GO TO 4.

4. CHECK THE INTAKE DOOR MOTOR CIRCUITS

Perform diagnostic procedure for the intake door motor. Refer to [ATC-86, "Intake Door Motor Circuit"](#) .

OK or NG

- OK >> GO TO 5.
NG >> Replace front air control or repair wiring. Refer to [ATC-160, "FRONT AIR CONTROL"](#) .

5. CHECK INTAKE DOOR OPERATION

Check and verify intake door mechanism for smooth operation.

OK or NG

- OK >> Replace intake door motor. Refer to [ATC-177, "INTAKE DOOR MOTOR"](#) .
NG >> Repair intake door mechanism.

TROUBLE DIAGNOSIS

SYSTEM DESCRIPTION

Component Parts

Intake door control system components are:

- Front air control
- Intake door motor (driver and passenger)
- PBR (built into intake door motors)
- In-vehicle sensor
- Ambient sensor
- Optical sensor
- Intake sensor

System Operation

The intake door control determines the intake door (driver and passenger) positions based on the position of the recirculation switch. When the recirculation switch is depressed the intake door motors rotate closing off the fresh air inlet and recirculating the cabin air. If the recirculation switch is depressed again, the intake door motors rotate in the opposite direction, again allowing fresh air into the cabin.

In the AUTO mode, the front air control determines the intake doors positions based on the ambient temperature, the intake air temperature and the in-vehicle temperature. When the DEFROST, or OFF switches are pushed or A/C switch is OFF, the front air control sets the intake doors at the fresh position. Recirculation is not allowed in DEFROST, D/F, or Floor modes.

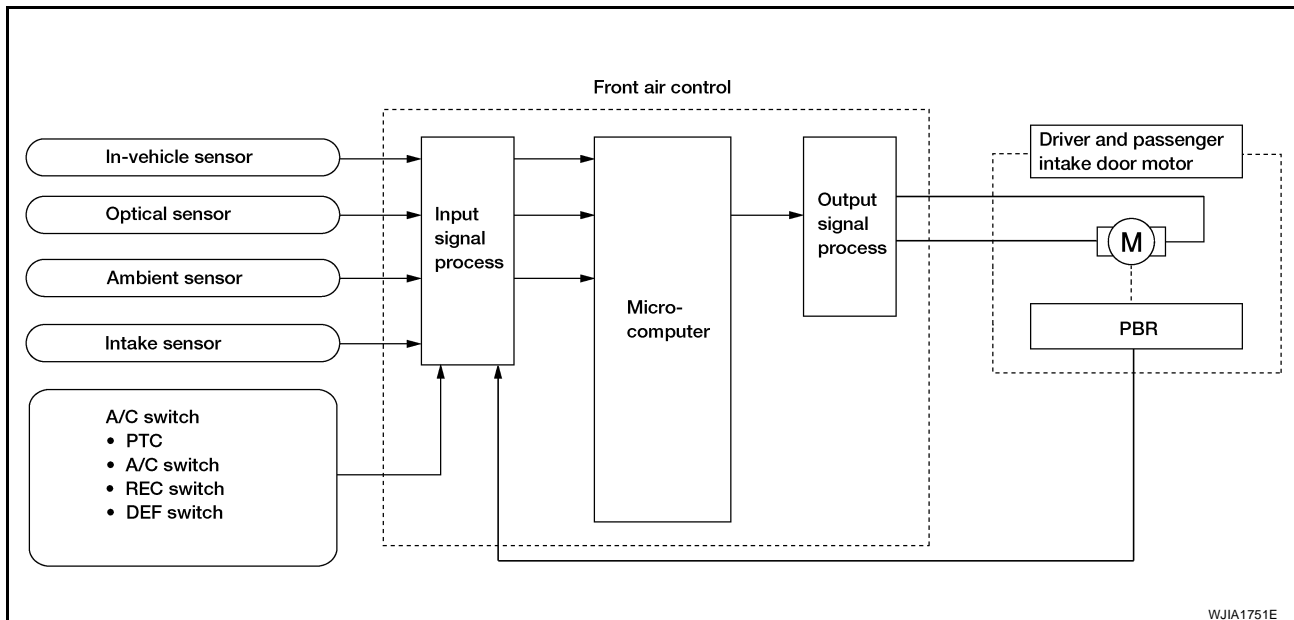

Intake Doors Control Specification

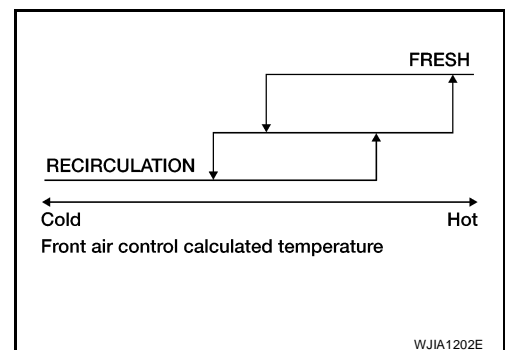

TROUBLE DIAGNOSIS

COMPONENT DESCRIPTION

Intake door motors

The driver and passenger intake door motors are attached to the intake unit. They rotate so that air is drawn from inlets set by the front air control. Motor rotation is conveyed to a lever which activates the intake door.

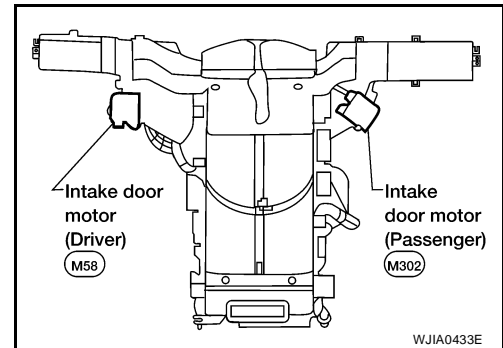

DIAGNOSTIC PROCEDURE FOR INTAKE DOOR MOTOR (DRIVER)

1. CHECK FRONT AIR CONTROL FOR POWER AND GROUND

1. Turn ignition switch ON.
2. Check voltage between front air control harness connector M49 terminal 22 and terminal 21 while placing the HVAC system into self-diagnostic mode. Refer to [ATC-53, "A/C System Self-diagnosis Function"](#).

Connector	Terminals		Condition	Voltage (Approx.)
	(+)	(-)		
Front air control: M49	22	21	Self-diagnostic mode	Battery voltage

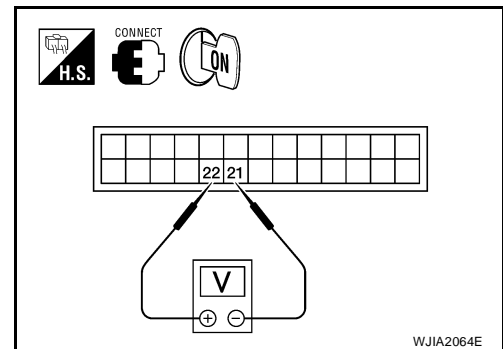

OK or NG

- OK >> GO TO 3.
 NG >> GO TO 2.

2. CHECK INTAKE DOOR MOTOR (DRIVER) CIRCUITS FOR SHORT TO GROUND

1. Turn ignition switch OFF.
2. Disconnect the front air control harness connector.
3. Check continuity between front air control harness connector M49 terminal 22, 21 and ground.

- 22 - Ground : Continuity should not exist.**
21 - Ground : Continuity should not exist.

OK or NG

- OK >> Replace front air control. Refer to [ATC-160, "FRONT AIR CONTROL"](#).
 NG >> Repair or replace harness as necessary.

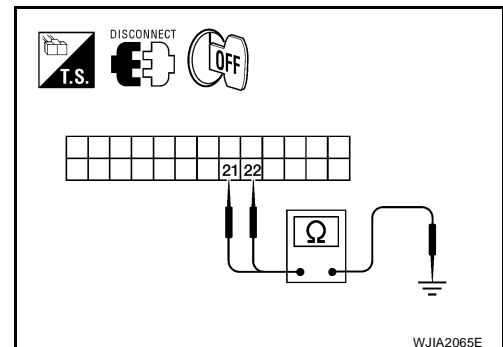

TROUBLE DIAGNOSIS

3. CHECK FRONT AIR CONTROL FOR GROUND AND POWER

1. Press the "BACK" button repeatedly to exit out of self-diagnostic mode.
2. Check voltage between front air control harness connector M49 terminal 22 and terminal 21 while placing the HVAC system into self-diagnostic mode. Refer to [ATC-53, "A/C System Self-diagnosis Function"](#).

Connector	Terminals		Condition	Voltage (Approx.)
	(+)	(-)		
Front air control: M49	21	22	Self-diagnostic mode	Battery voltage

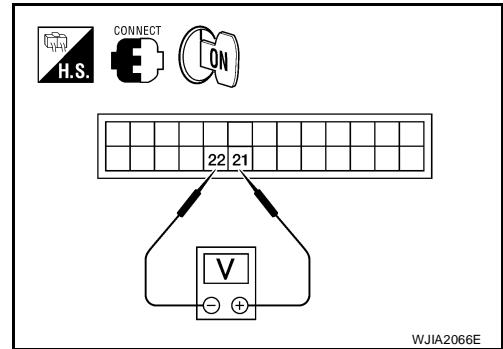

OK or NG

OK >> GO TO 4.

NG >> Replace front air control. Refer to [ATC-160, "FRONT AIR CONTROL"](#).

4. CHECK INTAKE DOOR MOTOR (DRIVER) AND CIRCUITS FOR OPEN

1. Turn ignition switch OFF.
2. Disconnect the front air control harness connector.
3. Check continuity between front air control harness connector M49 terminal 22 and terminal 21.

Continuity should exist.

OK or NG

OK >> Replace intake door motor (driver). Refer to [ATC-178, "DRIVER SIDE"](#).

NG >> GO TO 5.

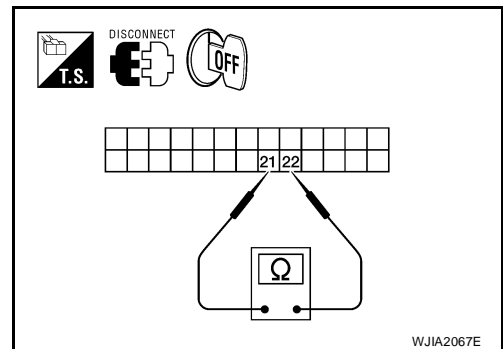

5. CHECK INTAKE DOOR MOTOR (DRIVER) CIRCUITS FOR OPEN

1. Disconnect the intake door motor (driver) harness connector.
2. Check continuity between front air control harness connector M49 (A) terminal 22, 21 and the intake door motor (driver) harness connector M58 (B) terminal 1, 6.

1 - 22 : Continuity should exist.

6 - 21 : Continuity should exist.

OK or NG

OK >> Replace intake door motor (driver). Refer to [ATC-178, "DRIVER SIDE"](#).

NG >> Repair or replace harness as necessary.

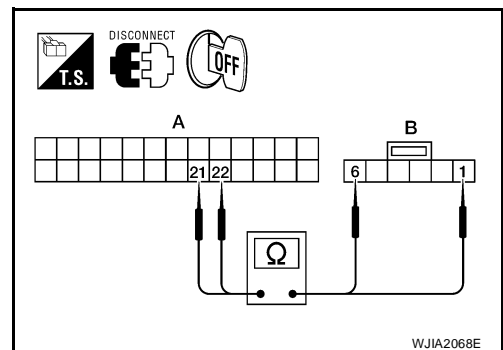

A
B
C
D
E
F
G
H
I
K
L
M

ATC

TROUBLE DIAGNOSIS

DIAGNOSTIC PROCEDURE FOR INTAKE DOOR MOTOR (PASSENGER)

1. CHECK FRONT AIR CONTROL FOR POWER AND GROUND

1. Turn ignition switch ON.
2. Check voltage between front air control harness connector M50 terminal 45 and terminal 46 while placing the HVAC system into self-diagnostic mode. Refer to [ATC-53, "A/C System Self-diagnosis Function"](#) .

Connector	Terminals		Condition	Voltage (Approx.)
	(+)	(-)		
Front air control: M50	45	46	Self-diagnostic mode	Battery voltage

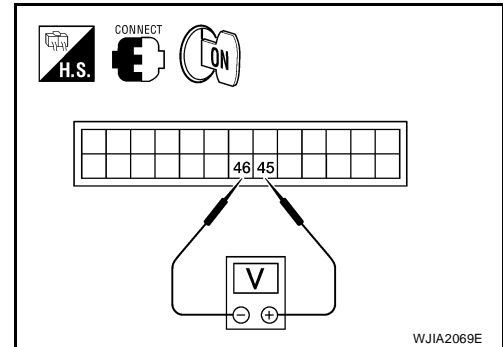

OK or NG

- OK >> GO TO 3.
 NG >> GO TO 2.

2. CHECK INTAKE DOOR MOTOR (PASSENGER) CIRCUITS FOR SHORT TO GROUND

1. Turn ignition switch OFF.
2. Disconnect the front air control harness connector.
3. Check continuity between front air control harness connector M50 terminal 46, 45 and ground.

- 46 - Ground : Continuity should not exist.**
45 - Ground : Continuity should not exist.

OK or NG

- OK >> Replace front air control. Refer to [ATC-160, "FRONT AIR CONTROL"](#) .
 NG >> Repair or replace harness as necessary.

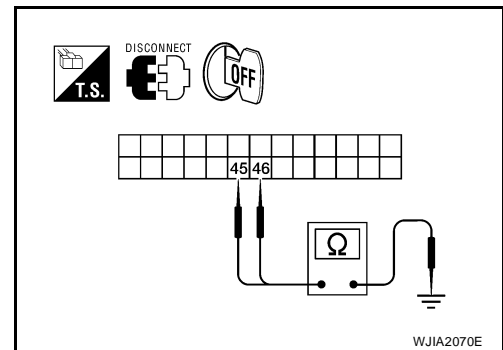

3. CHECK FRONT AIR CONTROL FOR GROUND AND POWER

1. Press the "BACK" button repeatedly to exit out of self-diagnostic mode.
2. Check voltage between front air control harness connector M50 terminal 46 and terminal 45 while placing the HVAC system into self-diagnostic mode. Refer to [ATC-53, "A/C System Self-diagnosis Function"](#) .

Connector	Terminals		Condition	Voltage (Approx.)
	(+)	(-)		
Front air control: M50	46	45	Self-diagnostic mode	Battery voltage

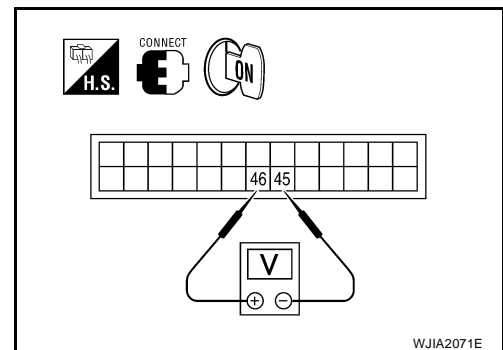

OK or NG

- OK >> GO TO 4.
 NG >> Replace front air control. Refer to [ATC-160, "FRONT AIR CONTROL"](#) .

TROUBLE DIAGNOSIS

4. CHECK INTAKE DOOR MOTOR (PASSENGER) AND CIRCUITS FOR OPEN

1. Turn ignition switch OFF.
2. Disconnect the front air control harness connector.
3. Check continuity between front air control harness connector M50 terminal 46 and terminal 45.

Continuity should exist.

OK or NG

- OK >> Replace intake door motor (passenger). Refer to [ATC-179, "PASSENGER SIDE"](#).
- NG >> GO TO 5.

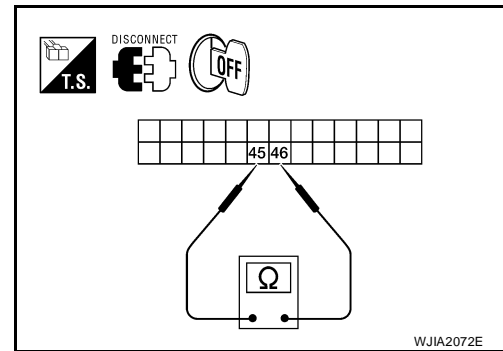

5. CHECK INTAKE DOOR MOTOR (PASSENGER) CIRCUITS FOR OPEN

1. Disconnect the intake door motor (passenger) harness connector.
2. Check continuity between front air control harness connector M50 terminal 46, 45 and the intake door motor (passenger) harness connector terminal 1, 6.

46 - 1 : Continuity should exist.

45 - 6 : Continuity should exist.

OK or NG

- OK >> Replace intake door motor (passenger). Refer to [ATC-179, "PASSENGER SIDE"](#).
- NG >> Repair or replace harness as necessary.

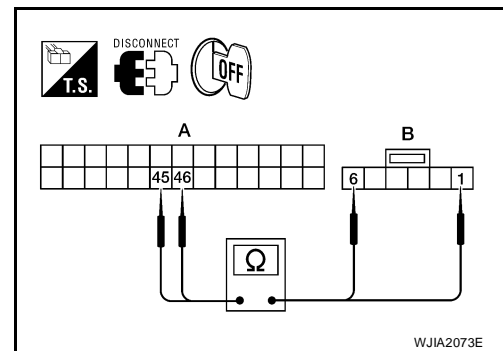

A
B
C
D
E
F
G
H
I
K
L
M

ATC

TROUBLE DIAGNOSIS

EJS004K5



Defroster Door Motor Circuit

SYMPTOM:

- Defroster door does not change.
- Defroster door does not operate normally.

INSPECTION FLOW

1. CONFIRM SYMPTOM BY PERFORMING OPERATIONAL CHECK - DEFROSTER DOOR

1. Press the vent switch ().
2. Press the defrost switch (). Defroster indicator should illuminate.
3. Listen for defroster door position change (blower sound should change slightly).

Can the symptom be duplicated?

YES >> GO TO 3.

NO >> GO TO 2.

2. CHECK FOR ANY SYMPTOMS

Perform a complete operational check for any symptoms. Refer to [ATC-55, "Operational Check \(Front\)"](#) .

Does another symptom exist?

YES >> Refer to [ATC-36, "SYMPTOM TABLE"](#) .

NO >> GO TO 6.

3. CHECK FOR SERVICE BULLETINS

Check for any service bulletins.

>> GO TO 4.

4. CHECK DEFROSTER DOOR MOTOR

Perform diagnostic procedure for defroster door motor. Refer to [ATC-94, "DIAGNOSTIC PROCEDURE FOR DEFROSTER DOOR MOTOR"](#) .

OK or NG

OK >> GO TO 5.

NG >> Repair PBR circuit or replace defroster door motor. Refer to [ATC-176, "DEFROSTER DOOR MOTOR"](#) .

5. CHECK DEFROSTER DOOR OPERATION

Check and verify defroster door mechanism for smooth operation.

OK or NG

OK >> Replace defroster door motor. Refer to [ATC-176, "DEFROSTER DOOR MOTOR"](#) .

NG >> Repair defroster door mechanism.

6. PERFORM SELF-DIAGNOSIS

Perform self-diagnosis to check for any codes. Refer to [ATC-53, "A/C System Self-diagnosis Function"](#) .

Are any self-diagnosis codes present?

YES >> Refer to [ATC-54, "SELF-DIAGNOSIS CODE CHART"](#) .

NO >> System OK.

TROUBLE DIAGNOSIS

SYSTEM DESCRIPTION

Component Parts

Defroster door control system components are:

- Front air control
- Defroster door motor
- PBR (built into defroster door motor)
- In-vehicle sensor
- Ambient sensor
- Optical sensor
- Intake sensor

System Operation

The front air control determines defroster door position based on the position of the defroster switch. When the defroster switch is depressed, the defroster door motor rotates directing air to the defroster ducts. When any mode other than defroster is selected, the defroster motor rotates in the opposite direction closing off air flow to the defroster ducts.

In the AUTO mode, the front air control determines defroster door position based on the ambient temperature, the intake air temperature and the in-vehicle temperature. Auto mode may be floor/defrost mode, but full defrost mode is only a manually selected mode.

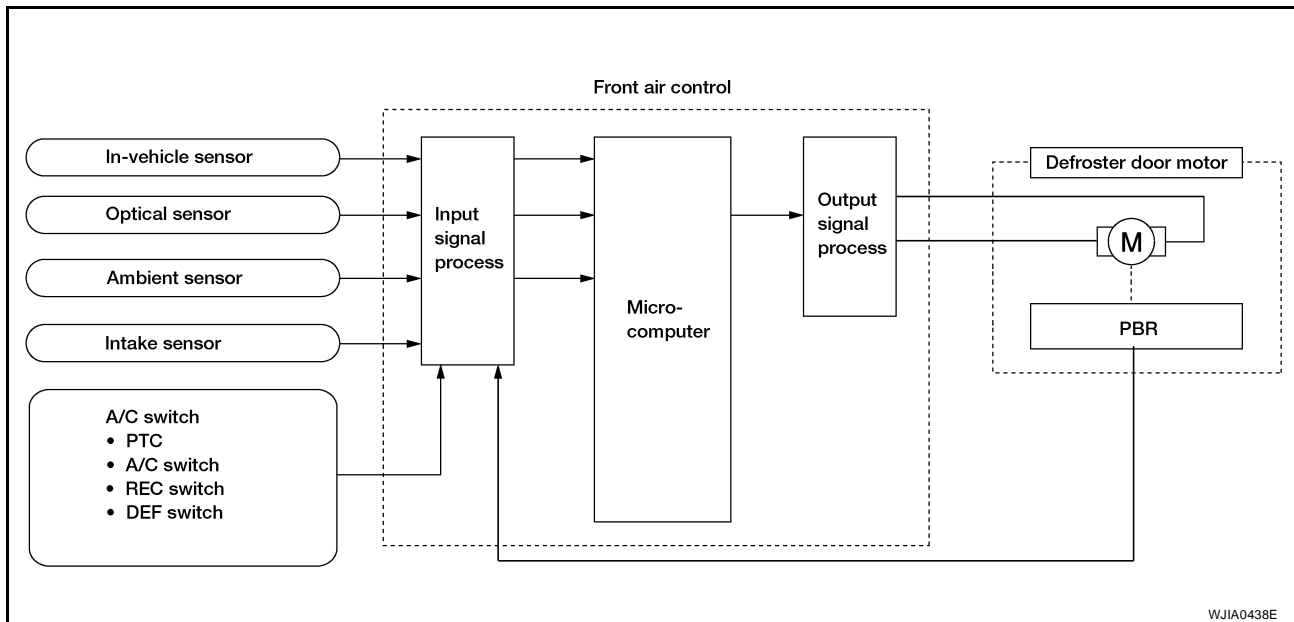

COMPONENT DESCRIPTION

Defroster door motor

The defroster door motor is attached to the front heater & cooling unit assembly. The front air control sends voltage to rotate the defroster door directing the air flow either to the defroster ducts, or to the floor ducts, depending on which way the voltage and ground are applied to the motor leads. Motor rotation is conveyed to a lever which activates the defroster door.

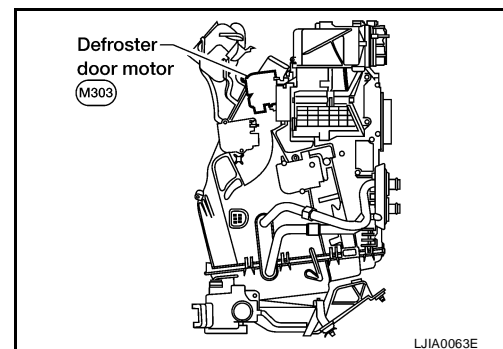

TROUBLE DIAGNOSIS

DIAGNOSTIC PROCEDURE FOR DEFROSTER DOOR MOTOR

1. CHECK FRONT AIR CONTROL FOR POWER AND GROUND

1. Turn ignition switch ON.
2. Check voltage between front air control harness connector M49 terminal 24 and terminal 23 while placing the HVAC system into self-diagnostic mode. Refer to [ATC-53, "A/C System Self-diagnosis Function"](#)

Connector	Terminals		Condition	Voltage (Approx.)
	(+)	(-)		
Front air control: M49	23	24	Self-diagnostic mode	Battery voltage

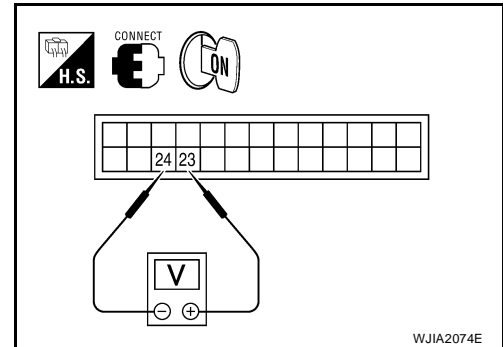

OK or NG

- OK >> GO TO 3.
 NG >> GO TO 2.

2. CHECK DEFROSTER DOOR MOTOR CIRCUITS FOR SHORT TO GROUND

1. Turn ignition switch OFF.
2. Disconnect the front air control harness connector.
3. Check continuity between front air control harness connector M49 terminal 23, 24 and ground.

- 24 - Ground : Continuity should not exist.**
23 - Ground : Continuity should not exist.

OK or NG

- OK >> Replace front air control. Refer to [ATC-160, "FRONT AIR CONTROL"](#).
 NG >> Repair or replace harness as necessary.

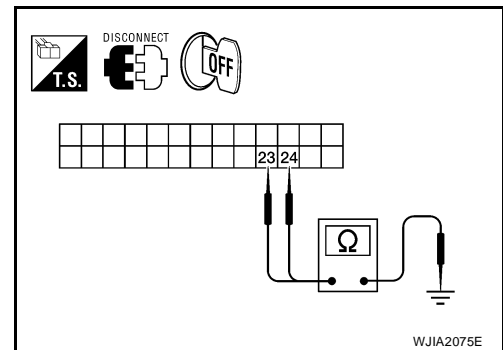

3. CHECK FRONT AIR CONTROL FOR GROUND AND POWER

1. Press the "BACK" button repeatedly to exit self-diagnostic mode.
2. Check voltage between front air control harness connector M49 terminal 23 and terminal 24 while placing the HVAC system into self-diagnostic mode. Refer to [ATC-53, "A/C System Self-diagnosis Function"](#).

Connector	Terminals		Condition	Voltage (Approx.)
	(+)	(-)		
Front air control: M49	24	23	Self-diagnostic mode	Battery voltage

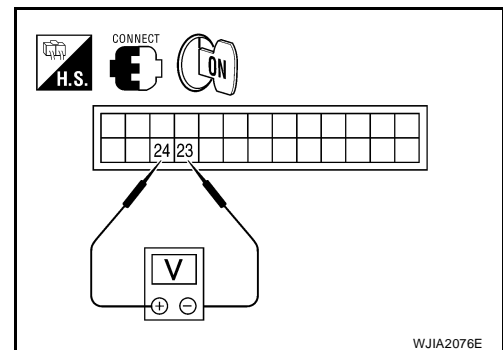

OK or NG

- OK >> GO TO 4.
 NG >> Replace front air control. Refer to [ATC-160, "FRONT AIR CONTROL"](#).

TROUBLE DIAGNOSIS

4. CHECK DEFROSTER DOOR MOTOR AND CIRCUITS FOR OPEN

1. Turn ignition switch OFF.
2. Disconnect the front air control harness connector.
3. Check continuity between front air control harness connector M49 terminal 23 and terminal 24.

Continuity should exist.

OK or NG

- OK >> Replace defroster door motor. Refer to [ATC-176](#), "[DEFROSTER DOOR MOTOR](#)".
- NG >> GO TO 5.

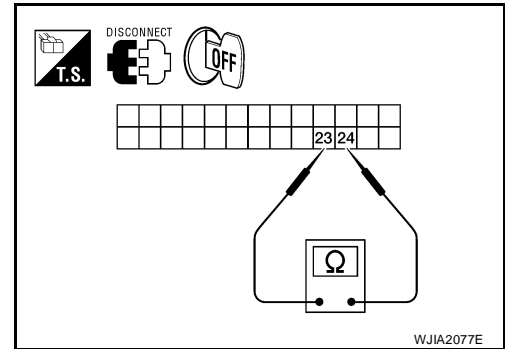

5. CHECK DEFROSTER DOOR MOTOR CIRCUITS FOR OPEN

1. Disconnect the defroster door motor harness connector.
2. Check continuity between front air control harness connector M49 (A) terminal 24, 23 and the defroster door motor harness connector M303 (B) terminal 1, 6.

24 - 1 : Continuity should exist.

23 - 6 : Continuity should exist.

OK or NG

- OK >> Replace defroster door motor. Refer to [ATC-176](#), "[DEFROSTER DOOR MOTOR](#)".
- NG >> Repair or replace harness as necessary.

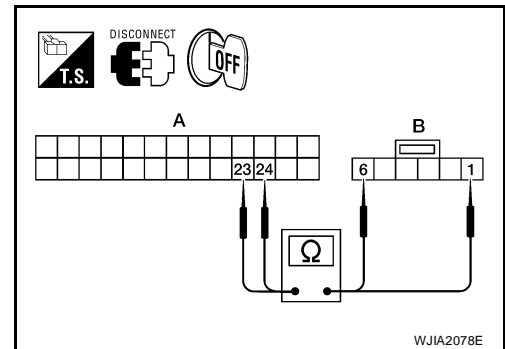

A
B
C
D
E
F
G
H
I

ATC

K
L
M

TROUBLE DIAGNOSIS

EJS004K6

Front Blower Motor Circuit

SYMPTOM:

- Blower motor operation is malfunctioning.

INSPECTION FLOW

1. CONFIRM SYMPTOM BY PERFORMING OPERATIONAL CHECK - FRONT BLOWER

1. Rotate the blower control dial clockwise. Blower should operate.
2. Rotate the blower control dial clockwise, and continue checking blower speed and fan symbol until all speeds are checked.

Can the symptom be duplicated?

- YES >> GO TO 3.
NO >> GO TO 2.

2. CHECK FOR ANY SYMPTOMS

Perform a complete operational check for any symptoms. Refer to [ATC-55, "Operational Check \(Front\)"](#) .

Does another symptom exist?

- YES >> Refer to [ATC-36, "SYMPTOM TABLE"](#) .
NO >> System OK.

3. CHECK FOR SERVICE BULLETINS

Check for any service bulletins.

>> GO TO 4.

4. PERFORM SELF-DIAGNOSIS

Perform self-diagnosis to check for any codes. Refer to [ATC-53, "A/C System Self-diagnosis Function"](#) .

Are any self-diagnosis codes present?

- YES >> Refer to [ATC-54, "SELF-DIAGNOSIS CODE CHART"](#) .
NO >> GO TO 5.

5. CHECK BLOWER MOTOR OPERATION

Check and verify blower motor operates in all speeds.

Does blower motor operate in all speeds?

- YES >> GO TO 6.
NO >> Refer to [ATC-98, "DIAGNOSTIC PROCEDURE FOR BLOWER MOTOR"](#) .

6. RECHECK FOR ANY SYMPTOMS

Perform a complete operational check for any symptoms. Refer to [ATC-55, "Operational Check \(Front\)"](#) .

Does another symptom exist?

- YES >> Refer to [ATC-36, "SYMPTOM TABLE"](#) .
NO >> Replace front air control. Refer to [ATC-160, "FRONT AIR CONTROL"](#) .

TROUBLE DIAGNOSIS

SYSTEM DESCRIPTION

Component Parts

Blower speed control system components are:

- Front air control
- Front Blower motor
- Front Blower motor relay
- Variable blower control (front)
- In-vehicle sensor
- Ambient sensor
- Optical sensor
- Intake sensor
- Engine coolant temperature (via CAN communication)

System Operation

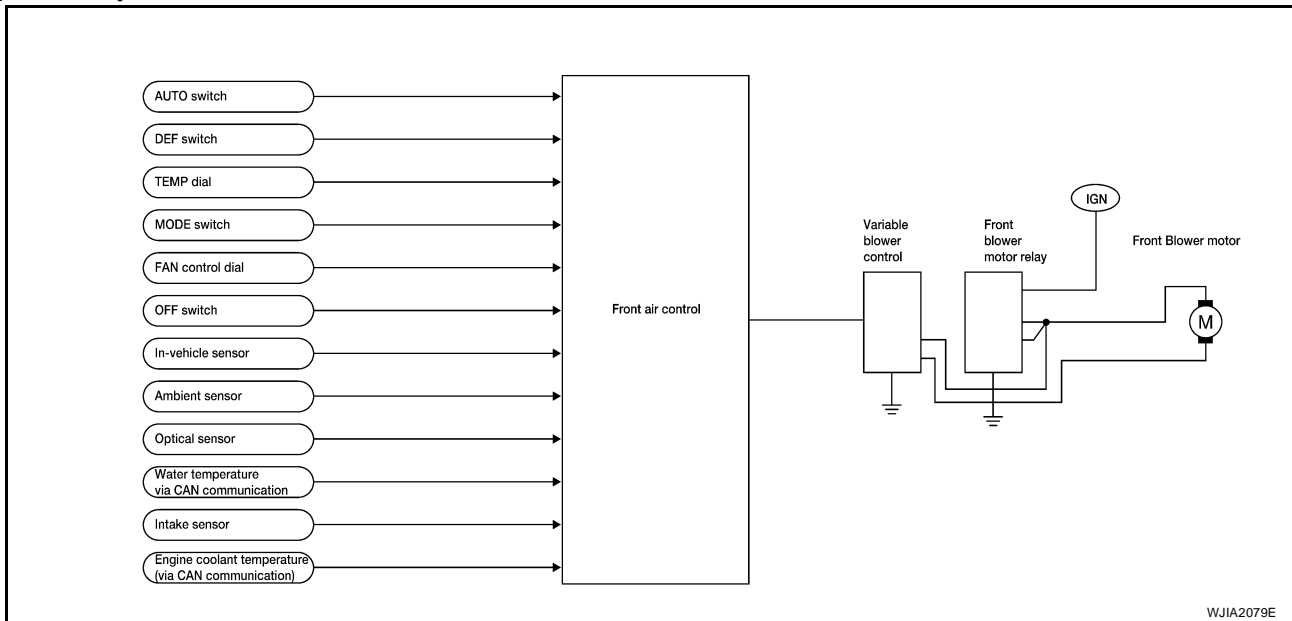

Automatic Mode

In the automatic mode, the blower motor speed is calculated by the front air control and variable blower control (front) based on input from the in-vehicle sensor, optical sensor, intake sensor and ambient sensor, engine coolant temperature sensor (via CAN communication), and potentiometer temperature control (PTC).

When the air flow is increased, the duty ratio of the blower fan motor's drive signal is changed at 8%/sec. to prevent a sudden increase in air flow.

In addition to manual air flow control and the usual automatic air flow control, starting air flow control, low engine coolant temperature starting control and high passenger compartment temperature starting control are available.

Starting Fan Speed Control

Start up from cold soak condition (Automatic mode).

In a cold start up condition where the engine coolant temperature is below 50°C (122°F), the blower will not operate at blower speed 1 for a short period of time (up to 210 seconds). The exact start delay time varies depending on the ambient and engine coolant temperatures.

In the most extreme case (very low ambient temperature) the blower starting delay will be 210 seconds as described above. After the engine coolant temperature reaches 50°C (122°F), or the 210 seconds has elapsed, the blower speed will increase to the objective blower speed.

Start up from normal operating or hot soak condition (Automatic mode).

The blower will begin operation momentarily after the AUTO switch is pushed. The blower speed will gradually rise to the objective speed over a time period of 3 seconds or less (actual time depends on the objective blower speed).

TROUBLE DIAGNOSIS

Blower Speed Compensation

Sunload

When the in-vehicle temperature and the set temperature are very close, the blower will be operating at low speed. The speed will vary depending on the sunload. During conditions of low or no sunload, the blower operates at low speed. During high sunload conditions, the front air control causes the blower speed to increase.

Blower Speed Control Specification

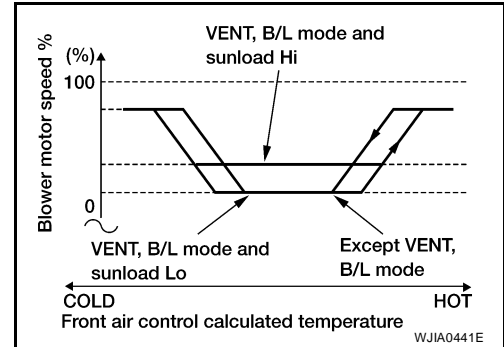

COMPONENT DESCRIPTION

Variable Blower Control (Front)

The variable blower control (front) is located on the cooling unit assembly. The variable blower control (front) receives a gate voltage from the front air control to steplessly maintain the blower fan motor voltage in the 0 to 5 volt range (approx.).

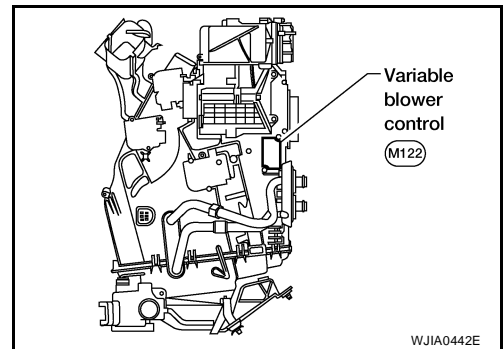

DIAGNOSTIC PROCEDURE FOR BLOWER MOTOR

SYMPTOM: Blower motor operation is malfunctioning under starting blower speed control.

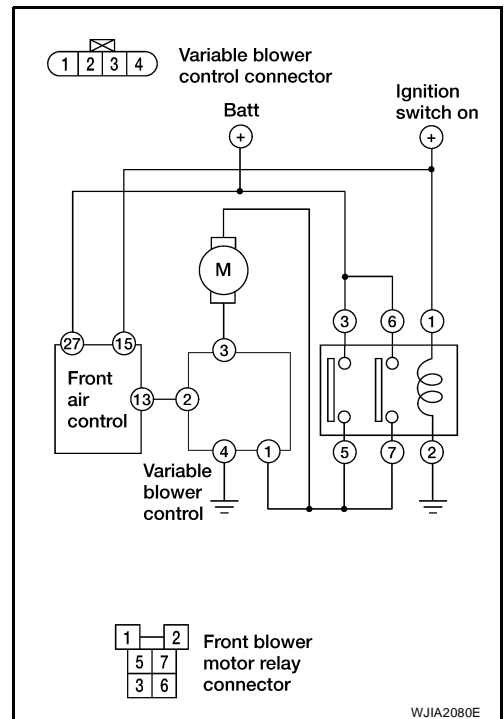

TROUBLE DIAGNOSIS

1. CHECK FUSES

Check 20A fuses (No. 28 and 30, located in the fuse and fusible link box). For fuse layout. Refer to [PG-85](#), "[FUSE AND FUSIBLE LINK BOX](#)".

Fuses are good.

OK or NG

- OK >> GO TO 2.
- NG >> GO TO 7.

2. CHECK FRONT BLOWER MOTOR POWER SUPPLY CIRCUIT

1. Turn ignition switch ON.
2. Press the AUTO switch.
3. Check voltage between front blower motor harness connector M62 terminal (+) and ground.

Battery voltage should exist.

OK or NG

- OK >> GO TO 12.
- NG >> GO TO 3.

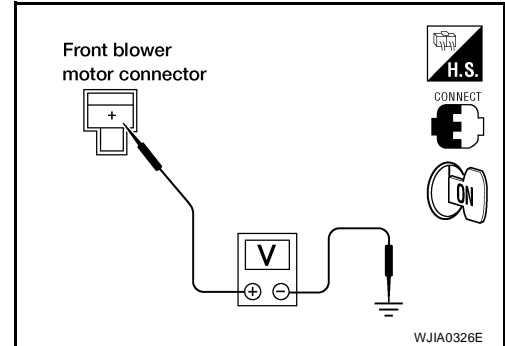

3. CHECK FRONT BLOWER MOTOR RELAY (SWITCH SIDE) POWER SUPPLY CIRCUIT

1. Turn ignition switch OFF.
2. Disconnect front blower motor relay connector.
3. Turn ignition switch ON.
4. Check voltage between front blower motor relay harness connector H-2 terminals 3 and 6 and ground.

Battery voltage should exist.

OK or NG

- OK >> GO TO 4.
- NG >> Repair harness or connector.

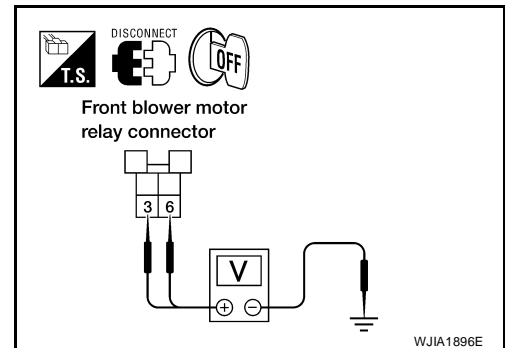

4. CHECK FRONT BLOWER MOTOR RELAY (COIL SIDE) POWER SUPPLY

Check voltage between front blower motor relay connector H-2 terminal 1 and ground.

Battery voltage should exist.

OK or NG

- OK >> GO TO 5.
- NG >> Repair harness or connector.

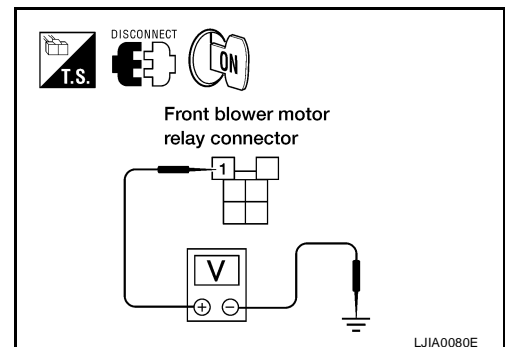

TROUBLE DIAGNOSIS

5. CHECK FRONT BLOWER MOTOR RELAY (SWITCH SIDE) CIRCUIT FOR OPEN

1. Turn ignition switch OFF.
2. Disconnect front blower motor connector.
3. Check continuity between front blower motor relay harness connector H-2 terminals 5 and 7 and front blower motor harness connector M62 terminal (+).

Continuity should exist.

OK or NG

- OK >> GO TO 6.
NG >> Repair harness or connector.

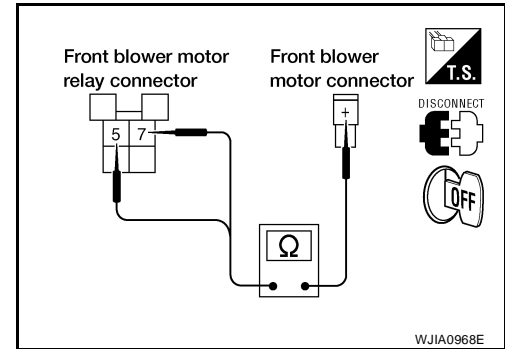

6. CHECK FRONT BLOWER MOTOR RELAY GROUND CIRCUIT

Check continuity between front blower motor relay harness connector H-2 terminal 2 and ground.

Continuity should exist.

OK or NG

- OK >> Replace blower motor relay.
NG >> Repair harness or connector.

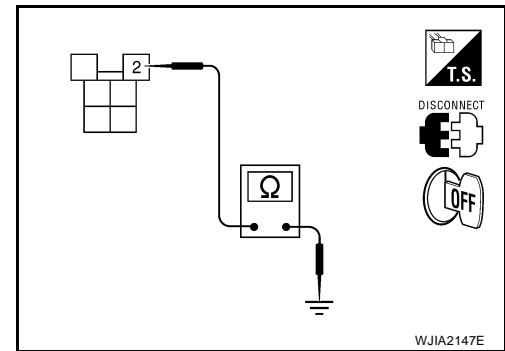

7. REPLACE FUSES

1. Replace fuses.
2. Turn ignition switch ON.
3. Activate the front blower motor.
4. Does fuse blow?

Yes or No

- Yes >> GO TO 8.
No >> Inspection End.

8. CHECK FRONT BLOWER MOTOR RELAY

1. Turn ignition switch OFF.
2. Check front blower motor relay. Refer to [ATC-103, "Front Blower Motor Relay"](#).

OK or NG

- OK >> GO TO 9.
NG >> Replace front blower motor relay.

9. CHECK FRONT BLOWER MOTOR

Check front blower motor. Refer to [ATC-104, "Front Blower Motor"](#).

OK or NG

- OK >> GO TO 10.
NG >> Replace front blower motor. Refer to [ATC-167, "FRONT BLOWER MOTOR"](#).

TROUBLE DIAGNOSIS

10. CHECK FRONT BLOWER MOTOR RELAY SUPPLY CIRCUITS FOR SHORT

Check continuity between front blower motor relay harness connector H-2 terminals 6 and 3 and ground.

Continuity should not exist.

OK or NG

- OK >> GO TO 11.
- NG >> Repair harness or connector.

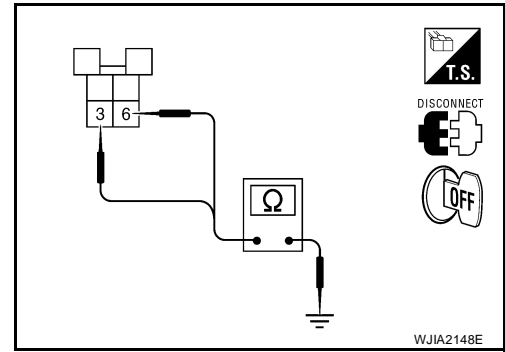

11. CHECK VARIABLE BLOWER CONTROL (FRONT) POWER SUPPLY CIRCUIT FOR SHORT

1. Disconnect variable blower control (front) harness connector.
2. Check continuity between variable blower control (front) harness connector M122 terminal 1 and ground.

Continuity should not exist.

OK or NG

- OK >> Replace variable blower control (front). Refer to [ATC-186, "VARIABLE BLOWER CONTROL \(FRONT\)"](#).
- NG >> Repair harness or connector.

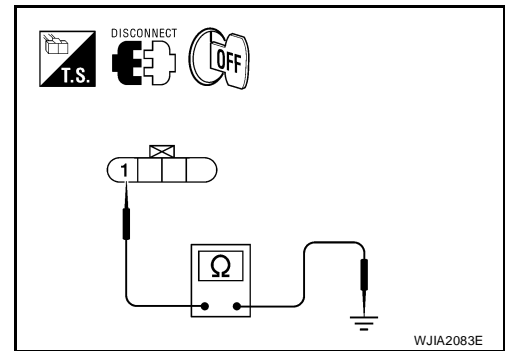

12. CHECK VARIABLE BLOWER CONTROL (FRONT) POWER SUPPLY CIRCUIT FOR OPEN

1. Turn ignition switch OFF.
2. Disconnect variable blower control (front) connector and front blower motor relay connector.
3. Check continuity between front blower motor relay harness connector H-2 (A) terminals 5 and 7 and variable blower control (front) harness connector M122 (B) terminal 1.

Continuity should exist.

OK or NG

- OK >> GO TO 13.
- NG >> Repair harness or connector.

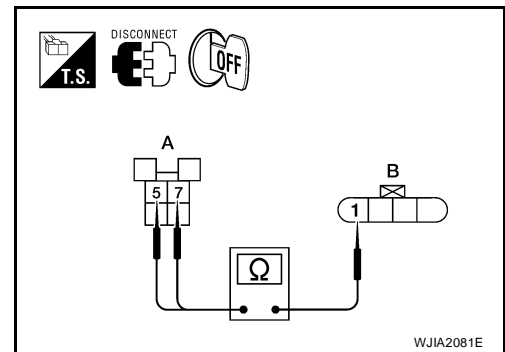

13. CHECK FRONT BLOWER MOTOR

Check front blower motor. Refer to [ATC-104, "Front Blower Motor"](#).

OK or NG

- OK >> GO TO 14.
- NG >> Replace front blower motor relay.

A
B
C
D
E
F
G
H
I
K
L
M

ATC

TROUBLE DIAGNOSIS

14. CHECK FRONT BLOWER MOTOR GROUND CIRCUIT

Check continuity between variable blower control (front) harness connector M122 (A) terminal 3 and front blower motor harness connector M62 (B) terminal (-).

Continuity should exist.

OK or NG

- OK >> GO TO 15.
- NG >> Repair harness or connector.

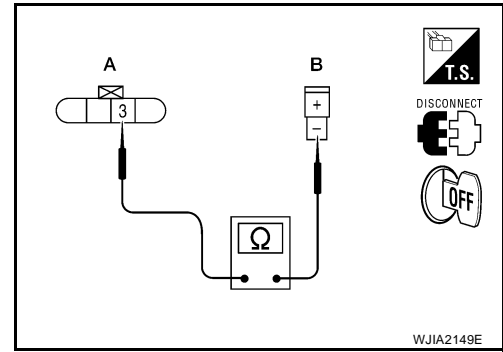

15. CHECK VARIABLE BLOWER CONTROL (FRONT) GROUND CIRCUIT

Check continuity between variable blower control (front) harness connector M122 terminal 4 and ground.

Continuity should exist.

OK or NG

- OK >> GO TO 16.
- NG >> Repair harness or connector.

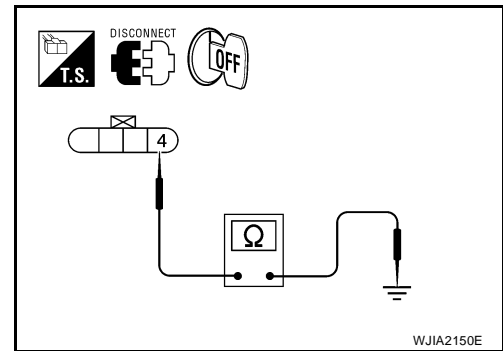

16. CHECK VARIABLE BLOWER CONTROL SIGNAL CIRCUIT

1. Disconnect front air control connector.
2. Check continuity between front air control connector M49 (B) terminal 13 and variable blower control (front) connector M122 (A) terminal 2.

Continuity should exist.

OK or NG

- OK >> GO TO 17.
- NG >> Repair harness or connector.

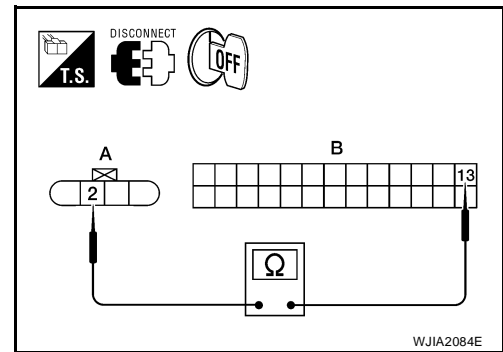

17. CHECK VARIABLE BLOWER CONTROL (FRONT) SIGNAL CIRCUIT

1. Reconnect all disconnected parts except the variable blower control (front) connector.
2. Turn ignition switch ON.
3. Turn front blower motor to maximum speed.
4. Check voltage between variable blower control (front) harness connector M122 terminal 2 and ground.

Connector	Terminals		Voltage (Approx.)
	(+)	(-)	
Front air control: M122	2	Ground	5V

OK or NG

- OK >> Replace variable blower control (front). Refer to [ATC-186, "VARIABLE BLOWER CONTROL \(FRONT\)"](#).
- NG >> Replace front air control. Refer to [ATC-160, "FRONT AIR CONTROL"](#).

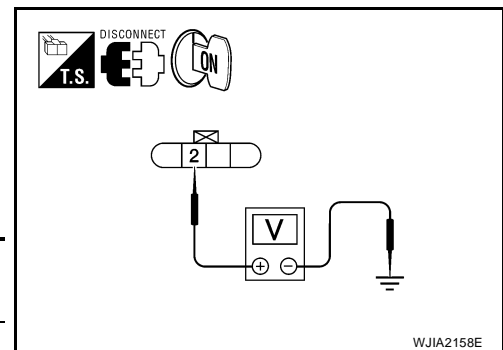

TROUBLE DIAGNOSIS

COMPONENT INSPECTION

Front Blower Motor Relay

Check continuity between terminals by supplying 12 volts and ground to coil side terminals of relay.

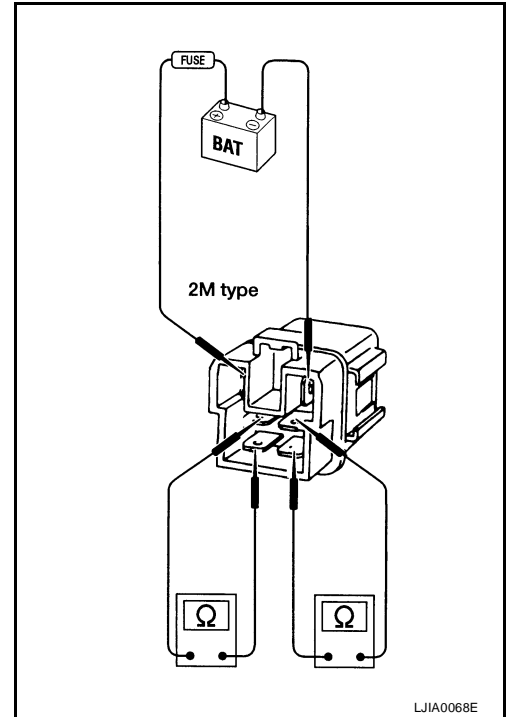

A
B
C
D
E
F
G
H
I

ATC

K
L
M

TROUBLE DIAGNOSIS

Front Blower Motor

Confirm smooth rotation of the blower motor.

- Ensure that there are no foreign particles inside the blower unit.
- Apply 12 volts to terminal (+) and ground to terminal (-) and verify that the motor operates freely and quietly.

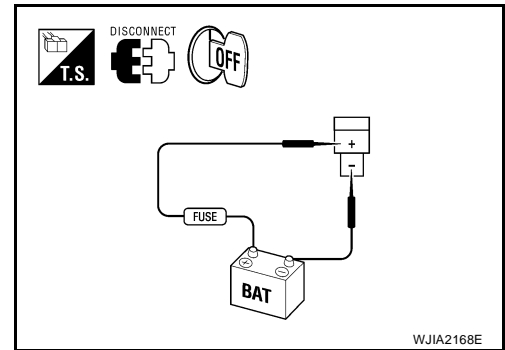

TROUBLE DIAGNOSIS

EJS004K7

Rear Blower Motor Circuit

SYMPTOM:

- Rear blower motor does not operate from the rear air control (front) and the rear air control (rear).
- Rear blower motor operates from rear air control (front) only.
- Rear blower motor operates from rear air control (rear) only.
- Rear blower motor speed does not match the rear air control (front) speed selected.
- Rear blower motor speed does not match the rear air control (rear) speed selected.
- Rear blower motor operates in high all the time when controlled from the rear air control (front).
- Rear blower motor operates in high all the time when controlled from the rear air control (rear).

INSPECTION FLOW

1. CONFIRM SYMPTOM BY PERFORMING OPERATIONAL CHECK - REAR AIR CONTROL (FRONT)

1. Press AUTO switch.
2. Turn the rear air control (front) blower control dial to the lowest speed and check for rear blower operation (REAR CTRL indicator off).
3. Continue checking that rear blower speed increases as the rear blower control dial is rotated clockwise.

Does the rear blower motor operate correctly?

- YES >> GO TO 3.
NO >> GO TO 2.

2. CONFIRM SYMPTOM BY PERFORMING OPERATIONAL CHECK - REAR AIR CONTROL (REAR)

1. Press the REAR CTRL switch (indicator on) on the rear air control (front) to send control of the rear blower motor back the rear air control (rear).
2. Turn the rear air control (rear) blower control dial to the lowest speed and check for rear blower operation.
3. Continue checking that rear blower speed increases as the rear blower control dial is rotated clockwise.

Does the rear blower motor operate correctly?

- YES >> ● Rear blower motor does not operate at any speed from the rear air control (front). Refer to [ATC-108, "TROUBLE DIAGNOSIS PROCEDURE 1"](#) .
- Rear blower motor operates in high speed all the time or does not match the rear air control (front) speed selected. Refer to [ATC-109, "TROUBLE DIAGNOSIS PROCEDURE 2"](#) .
- NO >> ● Rear blower motor does not operate from the rear air control (front) and the rear air control (rear). Refer to [ATC-110, "TROUBLE DIAGNOSIS PROCEDURE 3"](#)

3. CONFIRM SYMPTOM BY PERFORMING OPERATIONAL CHECK - REAR AIR CONTROL (REAR)

1. Press the REAR CTRL switch (indicator on) on the rear air control (front) to send control of the rear blower motor back the rear air control (rear).
2. Turn the rear air control (rear) blower control dial to the lowest speed and check for rear blower operation.
3. Continue checking that rear blower speed increases as the rear blower control dial is rotated clockwise.

Does the rear blower motor operate correctly?

- YES >> GO TO 4.
NO >> Check rear air control (rear). Refer to [ATC-115, "TROUBLE DIAGNOSIS PROCEDURE 4"](#) .

4. CHECK FOR SERVICE BULLETINS

Check for any service bulletins.

>> GO TO 5.

TROUBLE DIAGNOSIS

5. RECHECK FOR ANY SYMPTOMS

Perform a complete operational check for any symptoms. Refer to [ATC-55, "Operational Check \(Front\)"](#) .

Does another symptom exist?

YES >> Refer to [ATC-36, "SYMPTOM TABLE"](#) .

NO >> INSPECTION END.

TROUBLE DIAGNOSIS

SYSTEM DESCRIPTION

Component Parts

Rear blower speed control system components are:

- Front air control
- Rear air control (front)
- Rear air control (rear)
- Variable blower control (rear)
- Rear blower motor
- Rear blower motor relay

System Operation

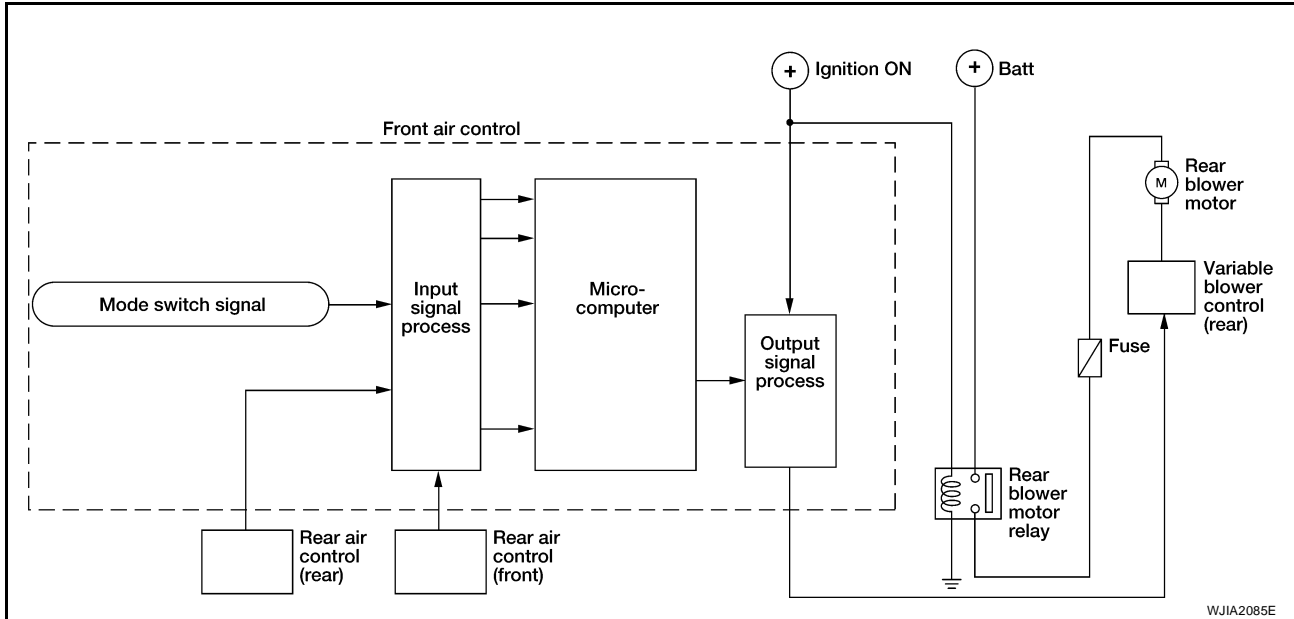

Rear Blower Control

NOTE:

The rear blower motor can only operate when the front blower motor is on.

When the rear air control (front) blower control dial is turned on and the REAR CTRL switch is pressed (indicator on), it allows the rear air control (rear) to control the rear blower motor speed. If the REAR CTRL switch is off (indicator off), the rear air control (front) controls the rear blower motor speed regardless of the rear air control (rear) blower speed control dial position.

COMPONENT DESCRIPTION

Variable Blower Control (Rear)

The variable blower control (rear) (1) is located on the rear blower motor case (1). The variable blower control (rear) receives a gate voltage from the front air control to steplessly maintain the blower fan motor voltage in the 0 to 5 volt range (approx.).

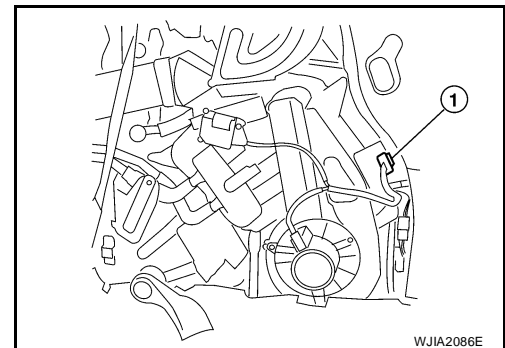

TROUBLE DIAGNOSIS

TROUBLE DIAGNOSIS PROCEDURE 1

1. CHECK REAR AIR CONTROL (FRONT) POWER SUPPLY

1. Disconnect rear air control (front) harness connector.
2. Turn ignition switch ON.
3. Check voltage between rear air control (front) harness connector R19 terminal 10 and ground.

Battery voltage should exist.

OK or NG

- OK >> GO TO 2.
NG >> Repair harness or connector.

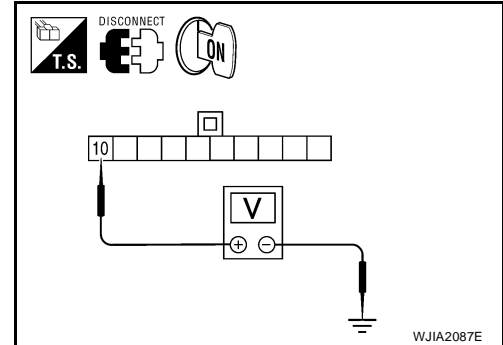

2. CHECK REAR AIR CONTROL (FRONT) FRONT AUX BLOWER POT REFERENCE VOLTAGE

1. Disconnect rear air control (front) harness connector.
2. Turn ignition switch ON.
3. Check voltage between rear air control (front) harness connector R19 terminal 6 and ground.

Connector	Terminals		Voltage (Approx.)
	(+)	(-)	
Rear air control (front): R19	6	Ground	5V

OK or NG

- OK >> GO TO 3.
NG >> Repair harness or connector.

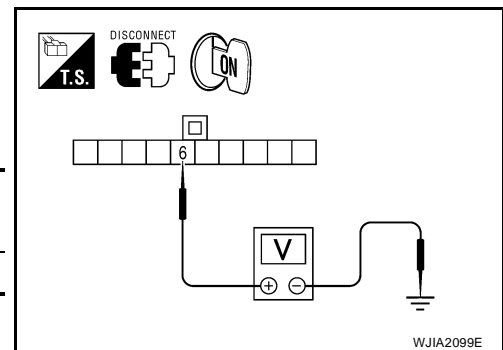

3. CHECK REAR AIR CONTROL (FRONT) GROUND CIRCUIT

Check continuity between rear air control (front) harness connector R19 terminal 1 and ground.

Continuity should exist.

OK or NG

- OK >> Replace rear air control (front).
NG >> Repair harness or connector.

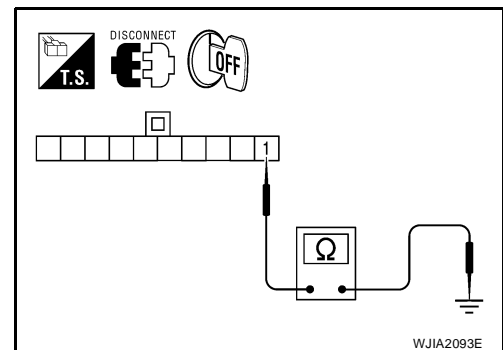

TROUBLE DIAGNOSIS

TROUBLE DIAGNOSIS PROCEDURE 2

1. CHECK REAR AIR CONTROL (FRONT) POWER SUPPLY

1. Disconnect rear air control (front) harness connector.
2. Turn ignition switch ON.
3. Check voltage between rear air control (front) harness connector R19 terminal 10 and ground.

Battery voltage should exist.

OK or NG

- OK >> GO TO 2.
 NG >> Repair harness or connector.

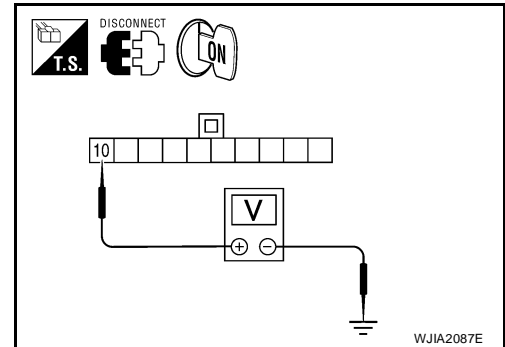

2. CHECK REAR AIR CONTROL (FRONT) FRONT AUX BLOWER POT REFERENCE VOLTAGE

1. Disconnect rear air control (front) harness connector.
2. Turn ignition switch ON.
3. Check voltage between rear air control (front) harness connector R19 terminal 6 and ground.

Connector	Terminals		Voltage (Approx.)
	(+)	(-)	
Rear air control (front): R19	6	Ground	5V

OK or NG

- OK >> GO TO 3.
 NG >> GO TO 4.

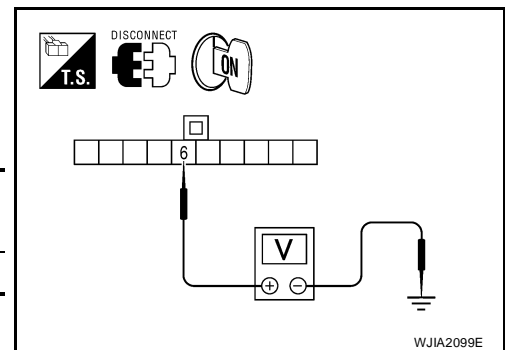

3. CHECK REAR AIR CONTROL (FRONT) GROUND CIRCUIT

1. Turn ignition switch OFF.
2. Check continuity between rear air control (front) harness connector R19 terminal 1 and ground.

Continuity should exist.

OK or NG

- OK >> Replace rear air control (front).
 NG >> Repair harness or connector.

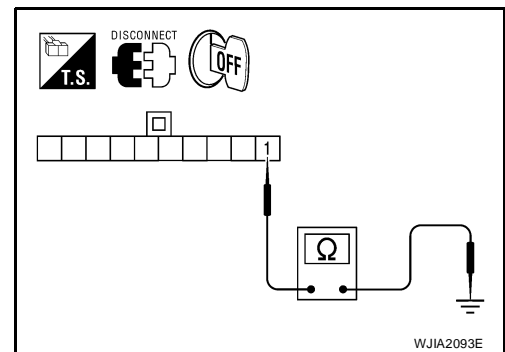

4. CHECK REAR AIR CONTROL (FRONT) BLOWER POT CIRCUIT FOR OPEN

1. Turn ignition switch OFF.
2. Disconnect front air control connector.
3. Check continuity between front air control harness connector M50 (A) terminal 49 and rear air control (front) harness connector R19 (B) terminal 6.

Continuity should exist.

OK or NG

- OK >> Replace front air control. Refer to [ATC-160, "FRONT AIR CONTROL"](#).
 NG >> Repair harness or connector.

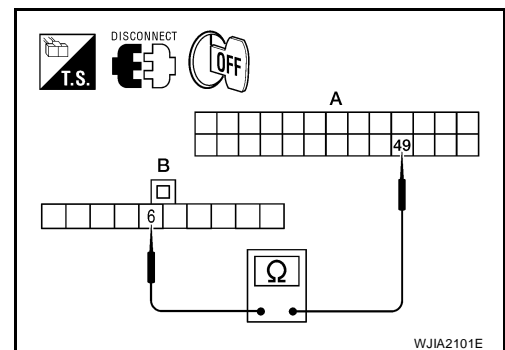

A
B
C
D
E
F
G
H
I
K
L
M

ATC

TROUBLE DIAGNOSIS

TROUBLE DIAGNOSIS PROCEDURE 3

1. CHECK REAR AIR CONTROL (FRONT)

1. Disconnect rear air control (front) connector.
2. Turn ignition switch ON.
3. Press AUTO switch.

Does rear blower motor operate in high speed?

- YES >> GO TO 17.
 NO >> GO TO 2.

2. CHECK REAR BLOWER MOTOR POWER SUPPLY

1. Turn ignition switch OFF.
2. Disconnect rear blower motor harness connector.
3. Turn ignition switch ON.
4. Press AUTO switch.
5. Rotate rear air control (front) blower speed control dial to maximum speed (REAR CTRL indicator off).
6. Check voltage between rear blower motor harness connector B134 terminal (+) and ground.

Battery voltage should exist.

OK or NG

- OK >> GO TO 3.
 NG >> GO TO 9.

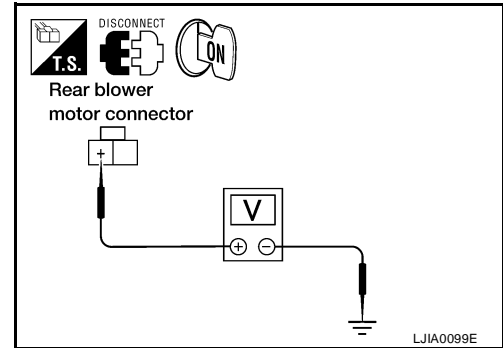

3. CHECK VARIABLE BLOWER CONTROL (REAR) POWER SUPPLY

1. Turn ignition switch OFF.
2. Disconnect variable blower control (rear) connector.
3. Turn ignition switch ON.
4. Check voltage between variable blower control connector B151 terminal 1 and ground.

Battery voltage should exist.

OK or NG

- OK >> GO TO 4.
 NG >> Repair harness or connector.

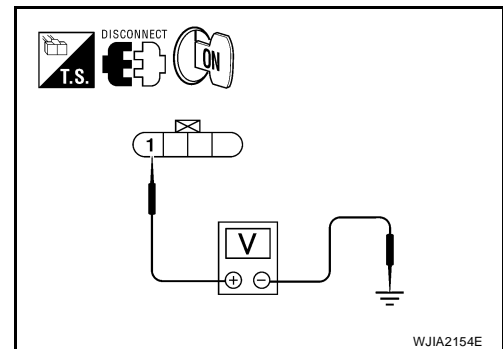

4. CHECK VARIABLE BLOWER CONTROL (REAR) AUX BLOWER SPEED SIGNAL CIRCUIT FOR SHORT

Check voltage between variable blower control (rear) harness connector B151 terminal 2 and ground.

Connector	Terminals		Voltage (Approx.)
	(+)	(-)	
Front air control: B151	2	Ground	4.5 V

OK or NG

- OK >> GO TO 5.
 NG >> GO TO 8.

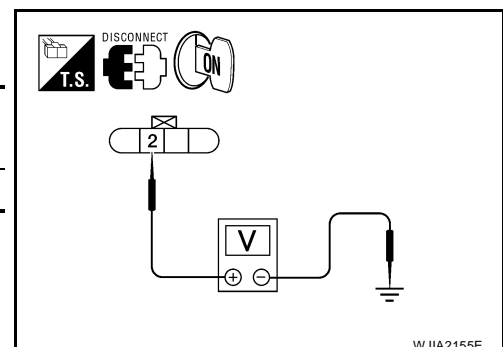

TROUBLE DIAGNOSIS

5. CHECK VARIABLE BLOWER CONTROL (REAR) GROUND CIRCUIT

1. Turn ignition switch OFF.
2. Check continuity between variable blower control (rear) harness connector B151 terminal 4 and ground.

Continuity should exist.

OK or NG

- OK >> GO TO 6.
NG >> Repair harness or connector.

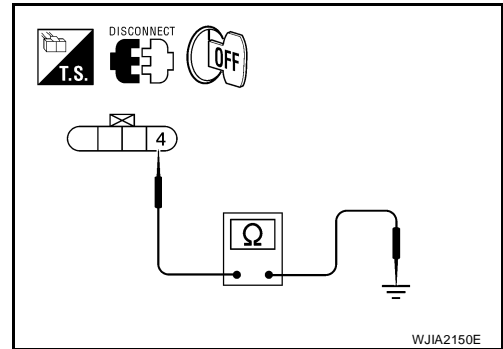

6. CHECK REAR BLOWER MOTOR

Check rear blower motor. Refer to [ATC-117, "Rear Blower Motor"](#).

OK or NG

- OK >> GO TO 7.
NG >> Replace rear blower motor. Refer to [ATC-167, "REAR BLOWER MOTOR"](#).

7. CHECK VARIABLE BLOWER CONTROL (REAR) BLOWER MOTOR GROUND CIRCUIT

Check continuity between rear blower motor connector B134 terminal (-) and variable blower control (rear) connector B151 terminal 3.

Continuity should exist.

OK or NG

- OK >> Replace front air control. Refer to [ATC-160, "FRONT AIR CONTROL"](#).
NG >> Repair harness or connector.

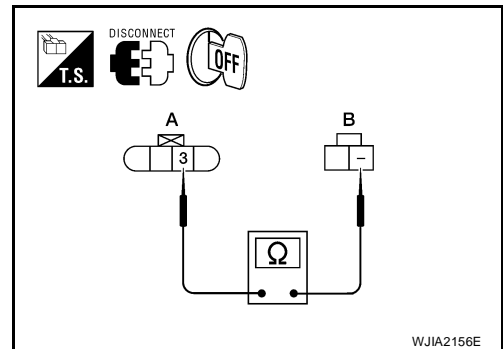

8. CHECK VARIABLE BLOWER CONTROL (REAR) AUX BLOWER SPEED CIRCUIT FOR OPEN

1. Turn ignition switch OFF.
2. Disconnect front air control connector.
3. Check continuity between front air control harness connector M49 (A) terminal 12 and variable blower control (rear) harness connector B151 (B) terminal 2.

Continuity should exist.

OK or NG

- OK >> Replace front air control. Refer to [ATC-160, "FRONT AIR CONTROL"](#).
NG >> Repair harness or connector.

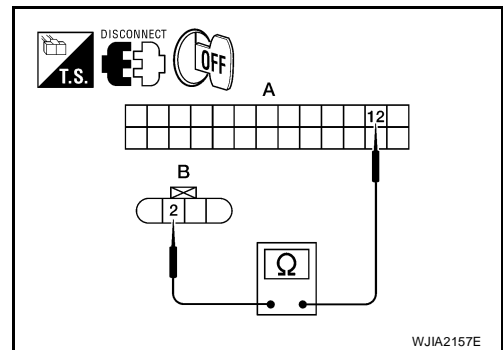

9. CHECK FUSES

Check 15A fuses [Nos. 10 and 11, located in the fuse block (J/B)]. Refer to [PG-84, "FUSE BLOCK-JUNCTION BOX \(J/B\)"](#).

OK or NG

- OK >> GO TO 10.
NG >> GO TO 14.

TROUBLE DIAGNOSIS

10. CHECK REAR BLOWER MOTOR RELAY

Check rear blower motor relay. Refer to [ATC-116, "Rear Blower Motor Relay"](#) .

OK or NG

- OK >> GO TO 11.
- NG >> Replace rear blower motor relay.

11. CHECK REAR BLOWER MOTOR CIRCUIT BETWEEN REAR BLOWER MOTOR AND FUSE BLOCK (J/B)

1. Turn ignition switch OFF.
2. Disconnect fuse block (J/B) M3 harness connector.
3. Check continuity between fuse block (J/B) harness connector M3 terminal 3N and 8N and rear blower motor harness connector B134 terminal (+).

Continuity should exist.

OK or NG

- OK >> GO TO 12.
- NG >> Repair harness or connector.

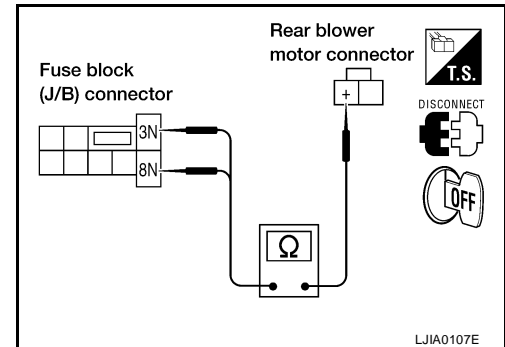

12. CHECK REAR BLOWER MOTOR RELAY (COIL SIDE) GROUND CIRCUIT

Check continuity between fuse block (J/B) harness connector M3 terminal 7N and ground.

Continuity should exist.

OK or NG

- OK >> GO TO 13.
- NG >> Repair harness or connector.

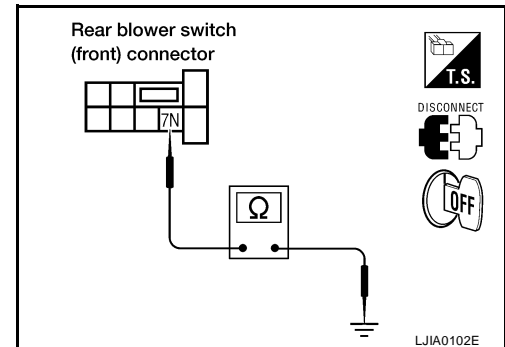

13. CHECK REAR BLOWER MOTOR RELAY (COIL SIDE) POWER SUPPLY CIRCUIT FOR OPEN

1. Turn ignition switch ON.
2. Check voltage between fuse block (J/B) connector E30 terminal 3Q and ground.

Battery voltage should exist.

OK or NG

- OK >> Replace fuse block (J/B).
- NG >> Repair harness or connector.

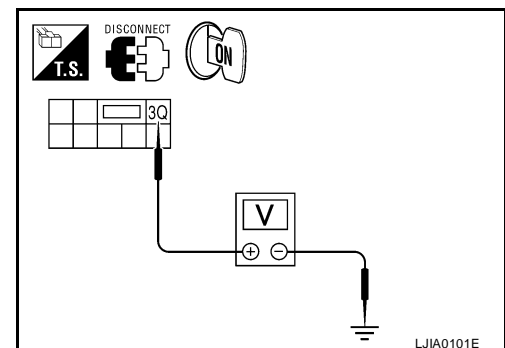

TROUBLE DIAGNOSIS

14. REPLACE FUSE

1. Turn ignition switch OFF.
2. Replace fuses.
3. Reconnect all disconnected parts.
4. Turn ignition switch ON.
5. Activate the rear blower motor from the rear air control (front).
6. Does fuse blow?

Yes or No

- Yes >> GO TO 15.
No >> Inspection End.

15. CHECK REAR BLOWER MOTOR

Check rear blower motor. Refer to [ATC-117, "Rear Blower Motor"](#).

OK or NG

- OK >> GO TO 16.
NG >> Replace rear blower motor. Refer to [ATC-167, "REAR BLOWER MOTOR"](#).

16. CHECK REAR BLOWER MOTOR POWER SUPPLY CIRCUIT FOR SHORT

1. Turn ignition switch OFF.
2. Disconnect fuse block (J/B) M3 harness connector and variable blower control (rear).
3. Check continuity between rear blower motor harness connector B134 terminal (+) and ground.

Continuity should not exist.

OK or NG

- OK >> Replace variable blower control (rear). Refer to [ATC-186, "VARIABLE BLOWER CONTROL \(REAR\)"](#).
NG >> Repair harness or connector.

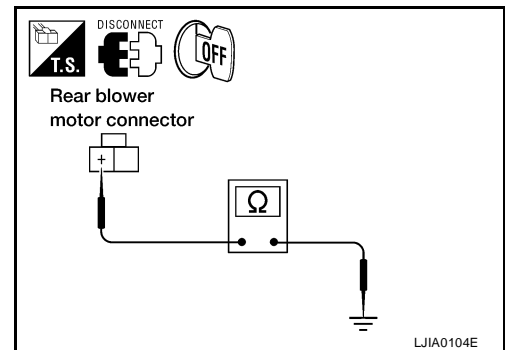

17. CHECK REAR AIR CONTROL (FRONT) POWER SUPPLY

Check voltage between rear air control (front) harness connector R19 terminal 10 and ground.

Battery voltage should exist.

OK or NG

- OK >> GO TO 18.
NG >> Repair harness or connector.

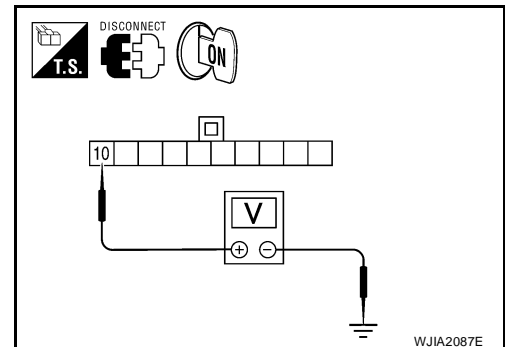

TROUBLE DIAGNOSIS

18. CHECK FRONT AIR CONTROL FRONT AUX BLOWER POT CIRCUIT FOR SHORT

1. Turn ignition switch OFF.
2. Disconnect front air control harness connector M50.
3. Check continuity between rear air control (front) harness connector R19 terminal 6 and ground.

Continuity should not exist.

OK or NG

- OK >> Replace rear air control (front) Refer to [ATC-160](#),
"REAR AIR CONTROL (FRONT)".
- NG >> Repair harness or connector.

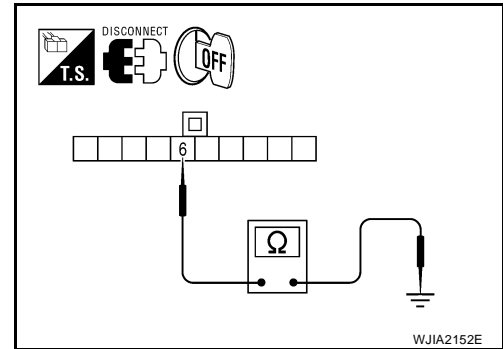

TROUBLE DIAGNOSIS

TROUBLE DIAGNOSIS PROCEDURE 4

1. CHECK REAR AIR CONTROL (REAR) REAR AUX BLOWER POT REFERENCE VOLTAGE

1. Turn ignition switch OFF.
2. Disconnect rear air control (rear) harness connector.
3. Turn ignition switch ON.
4. Check voltage between rear air control (rear) harness connector B150 terminal 6 and ground.

Connector	Terminals		Voltage (Approx.)
	(+)	(-)	
Rear air control (rear): B150	6	Ground	5V

OK or NG

- OK >> GO TO 2.
 NG >> GO TO 3.

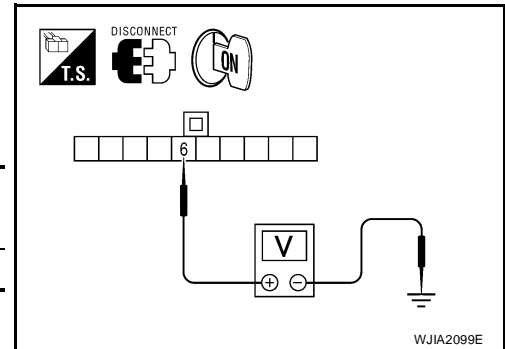

2. CHECK REAR AIR CONTROL (REAR) GROUND CIRCUITS

1. Turn ignition switch OFF.
2. Check continuity between rear air control (rear) harness connector B150 terminal 1, and 9 and ground.

Continuity should exist.

OK or NG

- OK >> Replace rear air control (rear). Refer to [ATC-160, "REAR AIR CONTROL \(REAR\)"](#)
 NG >> Repair harness or connector.

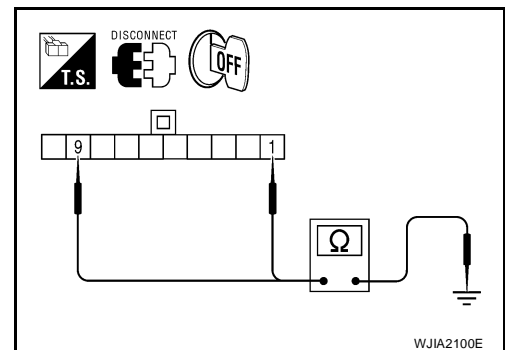

3. CHECK REAR AIR CONTROL (REAR) REAR AUX BLOWER POT FOR SHORT

1. Turn ignition switch OFF.
2. Check continuity between rear air control (rear) harness connector B150 terminal 6 and ground.

Continuity should not exist.

OK or NG

- OK >> GO TO 4.
 NG >> Repair harness or connector.

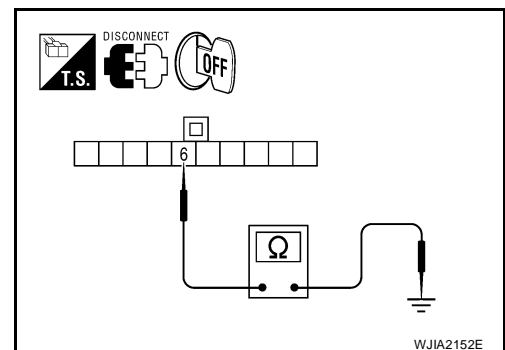

4. CHECK REAR AIR CONTROL (REAR) REAR AUX BLOWER POT BETWEEN FRONT AIR CONTROL AND REAR IAR CONTROL REAR

1. Disconnect front air control harness connector.
2. Check continuity between front air control harness connector M50 (A) terminal 47 and rear air control (rear) harness connector B150 (B) terminal 6.

Continuity should exist.

OK or NG

- OK >> Replace front air control. Refer to [ATC-160, "FRONT AIR CONTROL"](#).
 NG >> Repair harness or connector.

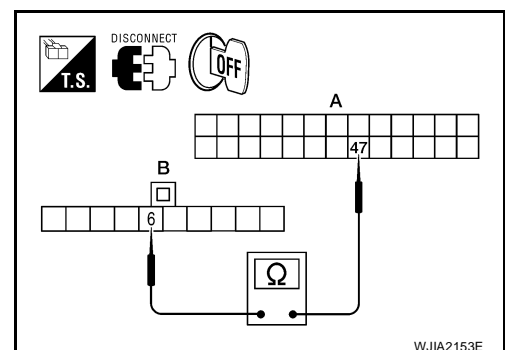

A
B
C
D
E
F
G
H
I
K
L
M

ATC

TROUBLE DIAGNOSIS

COMPONENT INSPECTION

Rear Blower Motor Relay

Check circuit continuity between terminals by supplying 12 volts and ground to coil side terminals of relays.

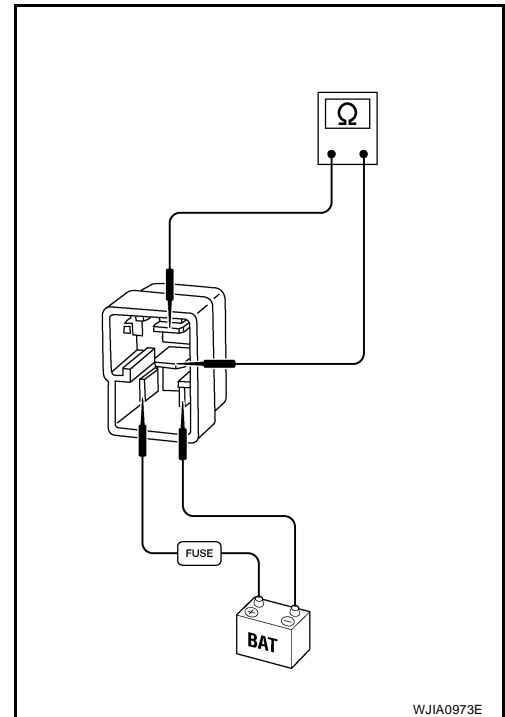

TROUBLE DIAGNOSIS

Rear Blower Motor

Check that there are no foreign particles inside the intake unit.
Apply 12 volts to terminal (+) and ground to terminal (-) and ensure that the blower motor rotates freely and quietly.

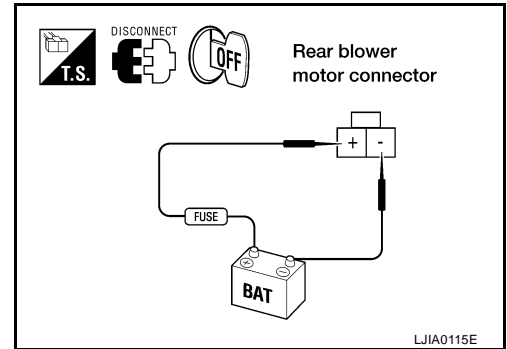

A
B
C
D
E
F
G
H
I

ATC

K
L
M

TROUBLE DIAGNOSIS

EJS004K8

Rear Air Temperature Control Circuit

SYMPTOM:

- Temperature cannot be adjusted from the rear air control.

INSPECTION FLOW

1. CONFIRM SYMPTOM BY PERFORMING REAR AIR CONTROL (FRONT) OPERATIONAL CHECK

1. Press AUTO switch (rear air controls only operate when front blower is on).
2. Turn the rear blower motor to maximum speed from the rear air control (front).
3. Turn rear air control (front) temperature/mode control dial clockwise and then counterclockwise (REAR CTRL indicator off).
4. Check for hot air at rear floor discharge air outlets in the maximum heat position and cold air at rear roof discharge air outlets in the maximum cold position.

Does the rear air control (front) operate properly?

YES >> GO TO 2.

NO >> Check rear air control (front). Refer to [ATC-119, "DIAGNOSTIC PROCEDURE FOR REAR AIR CONTROL \(FRONT\)"](#).

2. CONFIRM SYMPTOM BY PERFORMING REAR AIR CONTROL (REAR) OPERATIONAL CHECK

1. Press the REAR CTRL switch on rear air control (front) to send control to the rear air control (rear).
2. Turn the rear blower motor to maximum speed from the rear air control (rear).
3. Turn rear air control (rear) temperature/mode control dial slowly clockwise and then counterclockwise (REAR CTRL indicator on).
4. Check for hot air at rear floor discharge air outlets in the maximum heat position and cold air at rear roof discharge air outlets in the maximum cold position.

Does the rear air control (rear) operate properly?

YES >> GO TO 3.

NO >> Check rear air control (rear). Refer to [ATC-122, "DIAGNOSTIC PROCEDURE FOR REAR AIR CONTROL \(REAR\)"](#).

3. CHECK FOR ANY SYMPTOMS

Perform a complete operational check (rear) for any symptoms. Refer to [ATC-57, "Operational Check \(Rear\)"](#).

Does another symptom exist?

YES >> Refer to [ATC-36, "SYMPTOM TABLE"](#).

NO >> System OK.

4. CHECK FOR SERVICE BULLETINS

Check for any service bulletins.

>> GO TO 5.

5. PERFORM SELF-DIAGNOSIS

Perform self-diagnosis to check for any codes. Refer to [ATC-53, "A/C System Self-diagnosis Function"](#).

Are any self-diagnosis codes present?

YES >> Refer to [ATC-54, "SELF-DIAGNOSIS CODE CHART"](#).

NO >> System OK.

TROUBLE DIAGNOSIS

SYSTEM DESCRIPTION

Component Parts

Rear air control system components are:

- Front air control
- Rear air control (front)
- Rear air control (rear)
- Air mix door motor (rear)

System Operation

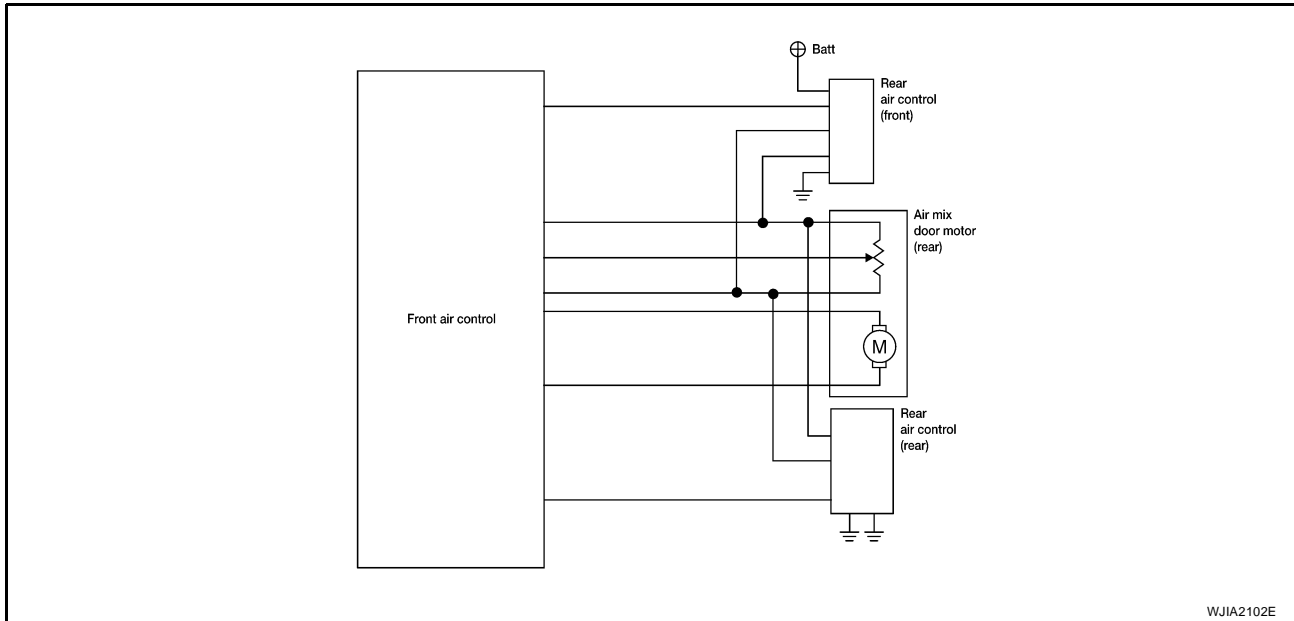

WJIA2102E

Rear Air Control

The front air control must be turned on before either rear air control can be used. When the REAR CTRL indicator is off the rear air control (front) will control all rear blower motor speeds and the rear temperature/mode operations. When the REAR CTRL switch is pressed (indicator on), the rear air control (rear) will control all the rear blower motor speeds and the rear temperature/mode operations.

DIAGNOSTIC PROCEDURE FOR REAR AIR CONTROL (FRONT)

SYMPTOM:

- Temperature/mode operation is malfunctioning.

1. CHECK REAR AIR CONTROL (FRONT) POWER SUPPLY

1. Disconnect rear air control (front) harness connector.
2. Turn ignition switch ON.
3. Check voltage between rear air control (front) harness connector R19 terminal 10 and ground.

Battery voltage should exist.

OK or NG

- OK >> GO TO 2.
- NG >> Repair harness or connector.

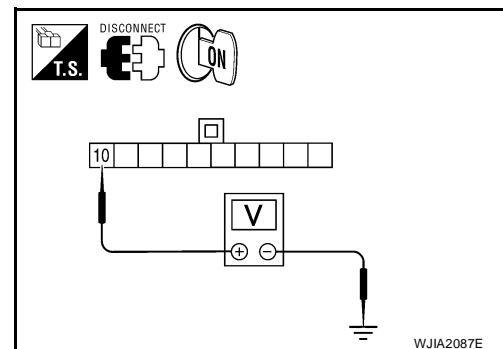

WJIA2087E

A
B
C
D
E
F
G
H
I

ATC

K
L
M

TROUBLE DIAGNOSIS

2. CHECK REAR AIR CONTROL (FRONT) REFERENCE VOLTAGE

Check voltage between rear air control (front) harness connector R19 terminal 3 and ground.

Connector	Terminals		Voltage (Approx.)
	(+)	(-)	
Rear air control (front): R19	3	Ground	4.5V

OK or NG

- OK >> GO TO 3.
- NG >> GO TO 6.

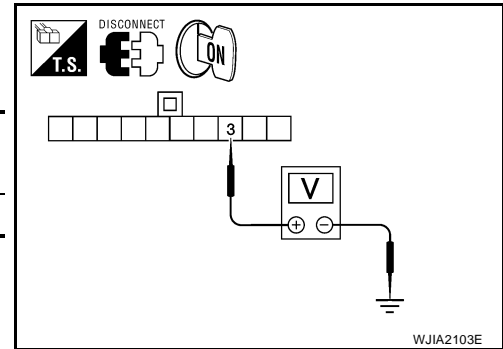

3. CHECK REAR AIR CONTROL (FRONT) AUX TEMP POT VOLTAGE

Check voltage between rear air control (front) harness connector R19 terminal 7 and ground.

Connector	Terminals		Voltage (Approx.)
	(+)	(-)	
Rear air control (front): R19	7	Ground	4.5V

OK or NG

- OK >> GO TO 4.
- NG >> GO TO 7.

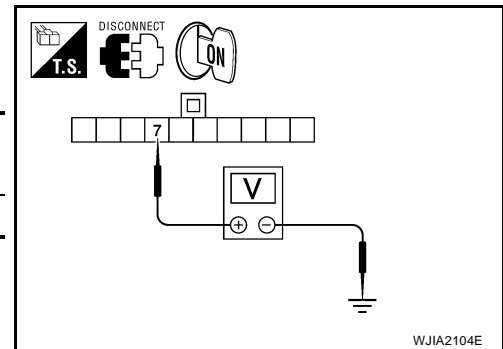

4. CHECK REAR AIR CONTROL (FRONT) GROUND CIRCUITS

1. Turn ignition switch OFF.
2. Check continuity between rear air control (front) harness connector R19 terminal 1 and ground.

Continuity should exist.

OK or NG

- OK >> GO TO 5.
- NG >> Repair harness or connector.

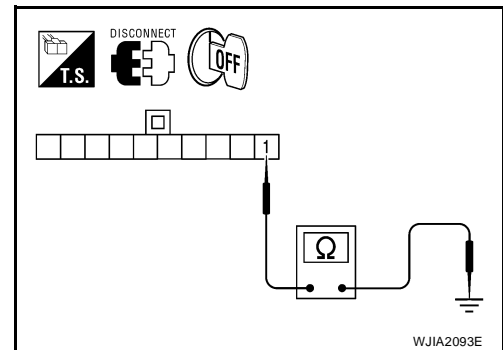

5. CHECK REAR AIR CONTROL (FRONT) REFERENCE GROUND CIRCUIT

Check continuity between rear air control (front) harness connector R19 terminal 8 and ground.

Continuity should exist.

OK or NG

- OK >> Replace rear air control (front). Refer to [ATC-160, "REAR AIR CONTROL \(FRONT\)"](#).
- NG >> GO TO 8.

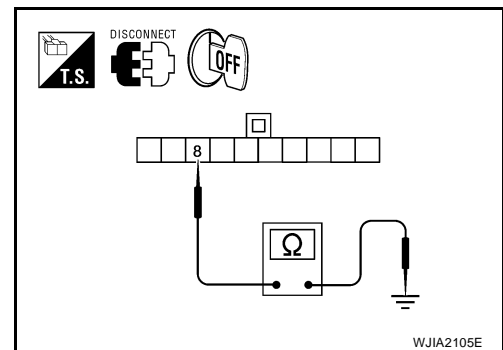

TROUBLE DIAGNOSIS

6. CHECK REAR AIR CONTROL (FRONT) REFERENCE VOLTAGE CIRCUIT

1. Turn ignition switch OFF.
2. Disconnect front air control connector.
3. Check continuity between front air control harness connector M50 (A) terminal 28 and rear air control (front) harness connector R19 (B) terminal 3.

Continuity should exist.

OK or NG

OK >> Replace front air control. Refer to [ATC-160, "FRONT AIR CONTROL"](#).

NG >> Repair harness or connector.

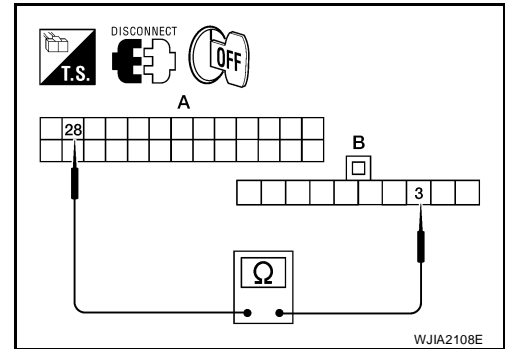

7. CHECK REAR AIR CONTROL (FRONT) AUX TEMP POT CIRCUIT

1. Turn ignition switch OFF.
2. Disconnect front air control connector.
3. Check continuity between front air control harness connector M50 (A) terminal 50 and rear air control (front) harness connector R19 (B) terminal 7.

Continuity should exist.

OK or NG

OK >> Replace front air control. Refer to [ATC-160, "FRONT AIR CONTROL"](#).

NG >> Repair harness or connector.

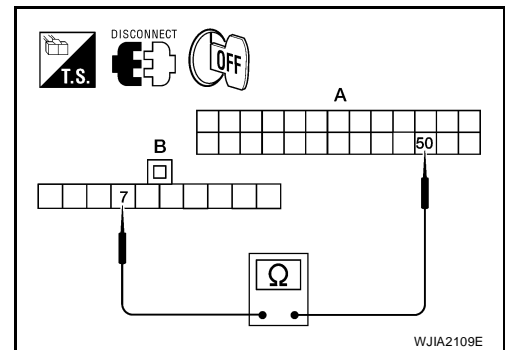

8. CHECK REAR AIR CONTROL (FRONT) REFERENCE GROUND CIRCUIT FOR OPEN

1. Disconnect front air control connector.
2. Check continuity between front air control harness connector M49 (A) terminal 3 and rear air control (front) harness connector R19 (B) terminal 8.

Continuity should exist.

OK or NG

OK >> Replace front air control. Refer to [ATC-160, "FRONT AIR CONTROL"](#).

NG >> Repair harness or connector.

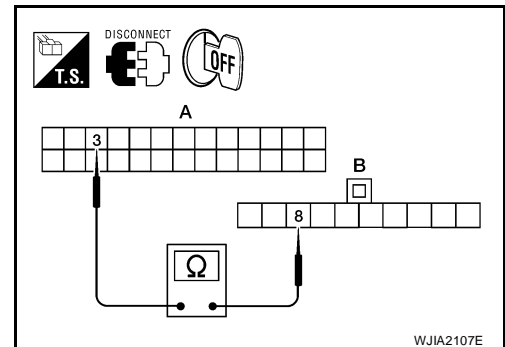

A
B
C
D
E
F
G
H
I
K
L
M

ATC

TROUBLE DIAGNOSIS

DIAGNOSTIC PROCEDURE FOR REAR AIR CONTROL (REAR)

1. CHECK REAR AIR CONTROL (REAR) AUX TEMPERATURE POT VOLTAGE

1. Turn ignition switch OFF.
2. Disconnect rear air control (rear).
3. Turn ignition switch ON.
4. Check voltage between rear air control (rear) harness connector B150 terminal 7 and ground.

Connector	Terminals		Voltage (Approx.)
	(+)	(-)	
Rear air control (rear): B150	7	Ground	4.5V

OK or NG

- OK >> GO TO 2.
 NG >> GO TO 5.

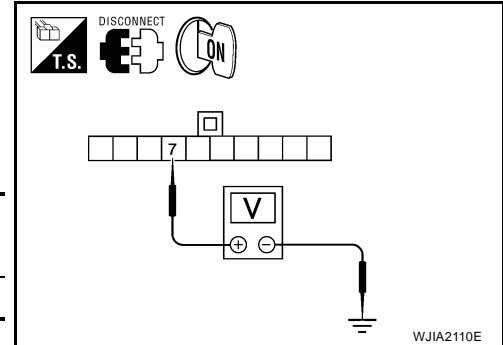

2. CHECK REAR AIR CONTROL (REAR) REFERENCE VOLTAGE

Check voltage between rear air control (rear) harness connector B150 terminal 3 and ground.

Connector	Terminals		Voltage (Approx.)
	(+)	(-)	
Rear air control (rear): B150	3	Ground	4.5V

OK or NG

- OK >> GO TO 3.
 NG >> GO TO 6

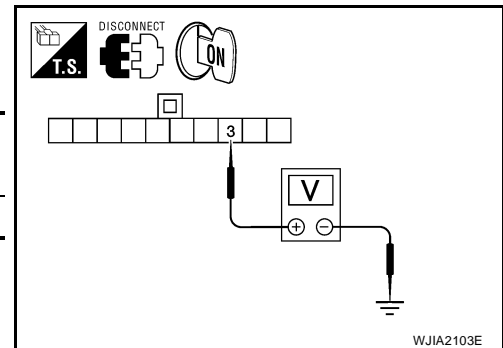

3. CHECK REAR AIR CONTROL (REAR) REFERENCE RETURN GROUND

1. Turn ignition switch OFF.
2. Check continuity between rear air control (rear) harness connector B150 terminal 8 and ground.

Continuity should exist.

OK or NG

- OK >> GO TO 4.
 NG >> GO TO 7.

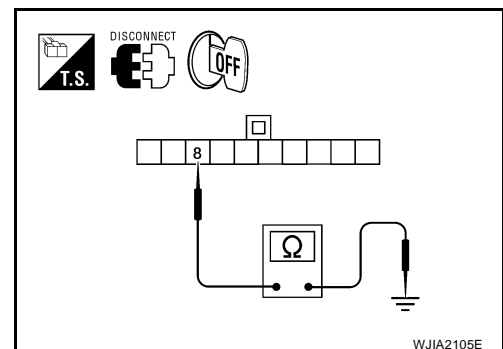

4. CHECK REAR AIR CONTROL (REAR) GROUND CIRCUITS

1. Check continuity between rear air control (rear) harness connector B150 terminal 9 and ground.

Continuity should exist.

2. Check continuity between rear air control (rear) harness connector B150 terminal 1 and ground.

Continuity should exist.

OK or NG

- OK >> Replace rear air control (rear). Refer to [ATC-160](#), "["REAR AIR CONTROL \(REAR\)"](#) .
 NG >> Repair harness or connector.

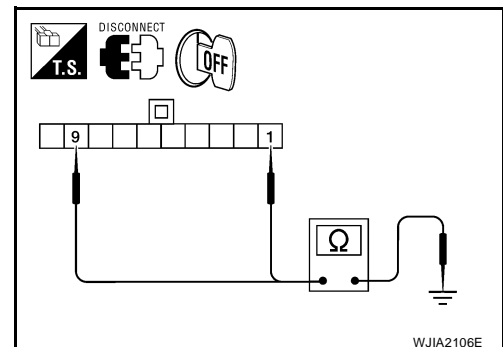

TROUBLE DIAGNOSIS

5. CHECK REAR AUX TEMP CIRCUIT BETWEEN REAR AIR CONTROL (REAR) AND FRONT AIR CONTROL FOR OPEN

1. Turn ignition switch OFF.
2. Disconnect front air control connector.
3. Check continuity between rear air control (rear) harness connector M50 (A) terminal 48 and rear air control (rear) harness connector B150 (B) terminal 7.

Continuity should exist.

OK or NG

- OK >> Replace front air control. Refer to [ATC-160, "FRONT AIR CONTROL"](#).
- NG >> Repair harness or connector.

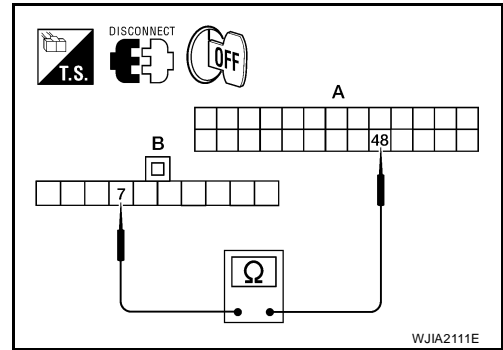

6. CHECK REFERENCE VOLATAGE CIRCUIT BETWEEN REAR AIR CONTROL (REAR) AND FRONT AIR CONTROL FOR OPEN

1. Turn ignition switch OFF.
2. Disconnect front air control connector.
3. Check continuity between rear air control (rear) harness connector M50 (A) terminal 28 and rear air control (rear) harness connector B150 (B) terminal 3.

Continuity should exist.

OK or NG

- OK >> Replace front air control. Refer to [ATC-160, "FRONT AIR CONTROL"](#).
- NG >> Repair harness or connector.

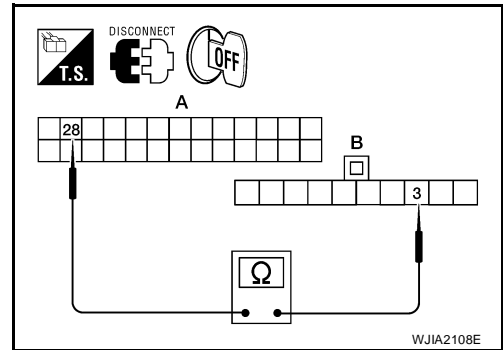

7. CHECK REFERENCE RETURN GROUND CIRCUIT BETWEEN REAR AIR CONTROL (REAR) AND FRONT AIR CONTROL FOR OPEN

1. Turn ignition switch OFF.
2. Disconnect front air control connector.
3. Check continuity between rear air control (rear) harness connector M49 (A) terminal 3 and rear air control (rear) harness connector B150 (B) terminal 8.

Continuity should exist.

OK or NG

- OK >> Replace front air control. Refer to [ATC-160, "FRONT AIR CONTROL"](#).
- NG >> Repair harness or connector.

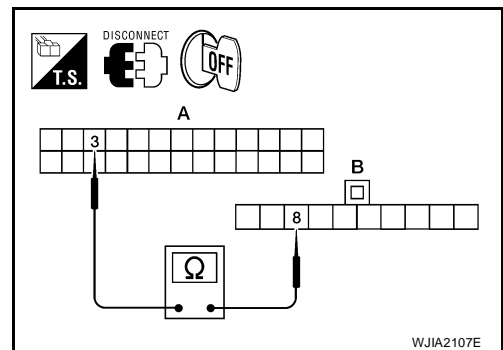

A
B
C
D
E
F
G
H
I
K
L
M

ATC

TROUBLE DIAGNOSIS

EJS004K9

Magnet Clutch Circuit

SYMPTOM: Magnet clutch does not engage.

INSPECTION FLOW

1. CONFIRM SYMPTOM BY PERFORMING OPERATIONAL CHECK - MAGNET CLUTCH

1. Turn ignition switch ON.
2. Press vent switch (❏).
3. Press the A/C switch.
4. Display shows ❏, A/C. Confirm that the compressor clutch engages (sound or visual inspection). (Discharge air and blower speed will depend on ambient, in-vehicle and set temperatures.)

Can the symptom be duplicated?

- YES >> GO TO 3.
NO >> GO TO 2.

2. CHECK FOR ANY SYMPTOMS

Perform a complete operational check for any symptoms. Refer to [ATC-55, "Operational Check \(Front\)"](#) .

Does another symptom exist?

- YES >> Refer to [ATC-36, "SYMPTOM TABLE"](#) .
NO >> System OK.

3. CHECK FOR SERVICE BULLETINS

Check for any service bulletins.

>> GO TO 4.

4. PERFORM SELF-DIAGNOSIS

Perform self-diagnosis to check for any codes. Refer to [ATC-53, "A/C System Self-diagnosis Function"](#) .

Are any self-diagnosis codes present?

- YES >> Refer to [ATC-54, "SELF-DIAGNOSIS CODE CHART"](#) .
NO >> GO TO 5.

5. CHECK AMBIENT SENSOR

Check and verify ambient sensor circuit. Refer to [ATC-148, "Ambient Sensor Circuit"](#) .

>> GO TO 6.

6. CHECK INTAKE SENSOR

Check and verify intake sensor circuit. Refer to [ATC-158, "Intake Sensor Circuit"](#) .

>> GO TO 7.

7. RECHECK FOR ANY SYMPTOMS

Perform a complete operational check for any symptoms. Refer to [ATC-55, "Operational Check \(Front\)"](#) .

Does another symptom exist?

- YES >> Refer to [ATC-36, "SYMPTOM TABLE"](#) .
NO >> Replace front air control. Refer to [ATC-160, "FRONT AIR CONTROL"](#) .

TROUBLE DIAGNOSIS

SYSTEM DESCRIPTION

The front air control controls compressor operation based on ambient and intake temperature and a signal from ECM.

Low Temperature Protection Control

The front air control will turn the compressor ON or OFF as determined by a signal detected by the intake sensor and the ambient sensor.

When intake air temperature is higher than the preset value, the compressor turns ON. The compressor turns OFF when intake air temperature is lower than the preset value. That preset value is dependent on the ambient temperature, refer to the following table.

Ambient temperature °C (°F)	Compressor ON intake temperature C (°F)	Compressor OFF intake temperature C (°F)
0 (32)	2.5 (37)	2.0 (36)
10 (50)	2.5 (37)	2.0 (36)
20 (68)	2.5 (37)	1.5 (35)
30 (86)	2.0 (36)	1.0 (34)
40 (104)	2.0 (36)	1.0 (34)
50 (122)	2.0 (36)	1.0 (34)

DIAGNOSTIC PROCEDURE FOR MAGNET CLUTCH

SYMPTOM: Magnet clutch does not engage when A/C switch is ON.

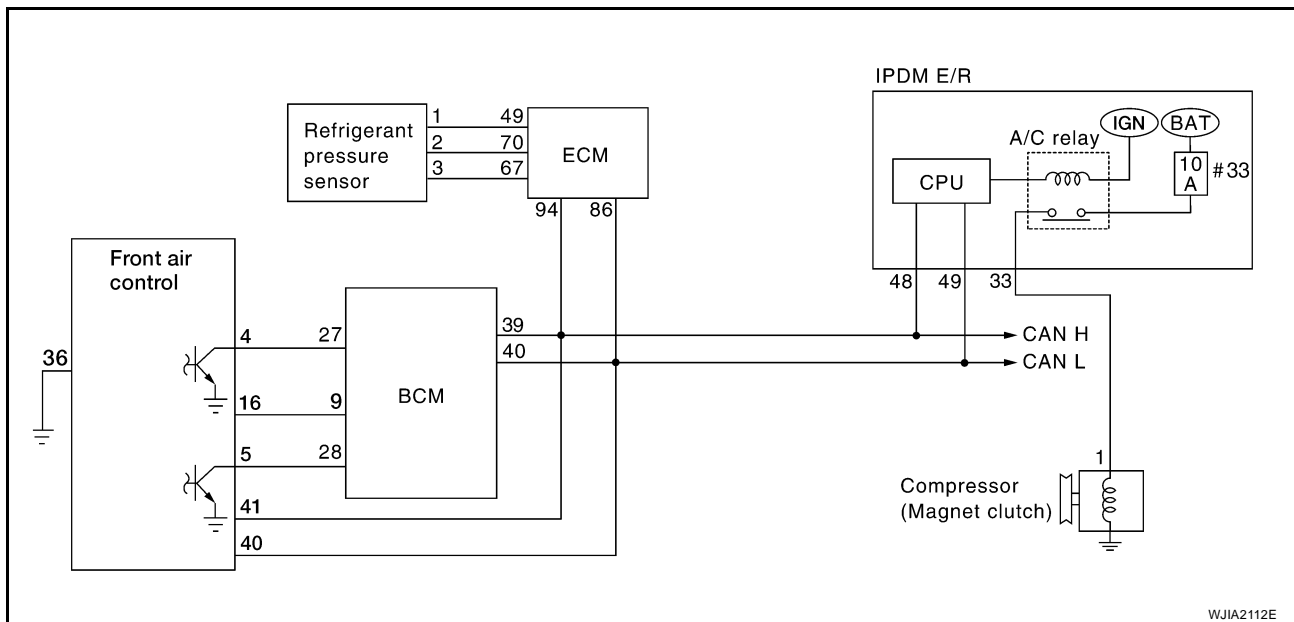

1. CHECK INTAKE SENSOR CIRCUIT

Check intake sensor. Refer to [ATC-53, "A/C System Self-diagnosis Function"](#) .

OK or NG

OK >> GO TO 2.

NG >> Malfunctioning intake sensor. Refer to [ATC-158, "Intake Sensor Circuit"](#) .

TROUBLE DIAGNOSIS

2. PERFORM AUTO ACTIVE TEST

Perform Auto Active Test. Refer to [PG-23, "Auto Active Test"](#) .
Does magnet clutch operate?

Yes or No

Yes >> ● WITH CONSULT-II
GO TO 5.

● WITHOUT CONSULT-II
GO TO 6.

No >> Check 10A fuse (No. 33, located in IPDM E/R), and GO TO 3.

3. CHECK CIRCUIT CONTINUITY BETWEEN IPDM E/R AND COMPRESSOR

1. Turn ignition switch OFF.
2. Disconnect IPDM E/R connector and compressor (magnet clutch) connector.
3. Check continuity between IPDM E/R harness connector E124 terminal 33 and compressor harness connector F3 terminal 1.

33 – 1 : Continuity should exist.

OK or NG

OK >> GO TO 4.

NG >> Repair harness or connector.

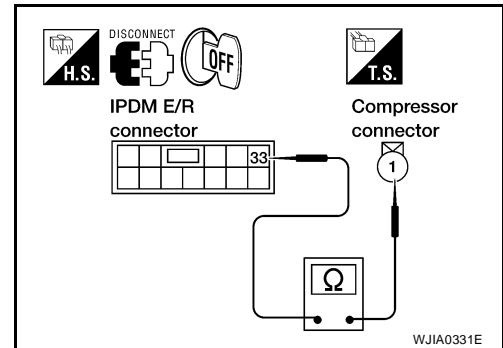

4. CHECK MAGNET CLUTCH CIRCUIT

Check for operation sound when applying battery voltage direct current to terminal.

OK or NG

OK >> Replace IPDM E/R. Refer to [PG-33, "Removal and Installation of IPDM E/R"](#) .

NG >> Replace magnet clutch. Refer to [ATC-198, "Removal and Installation for Compressor Clutch"](#) .

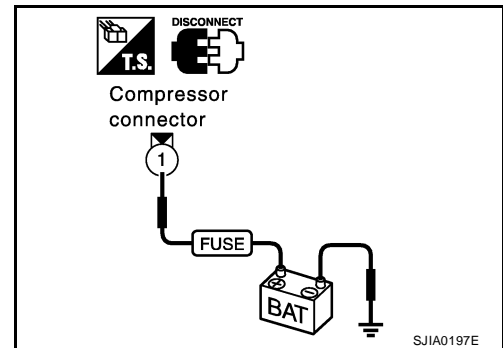

5. CHECK BCM INPUT (COMPRESSOR ON) SIGNAL

Check compressor ON/OFF signal. Refer to [ATC-35, "CONSULT-II Function \(BCM\)"](#) .

A/C SW ON : COMP ON SIG ON

A/C SW OFF : COMP ON SIG OFF

OK or NG

OK >> GO TO 8.

NG >> GO TO 6.

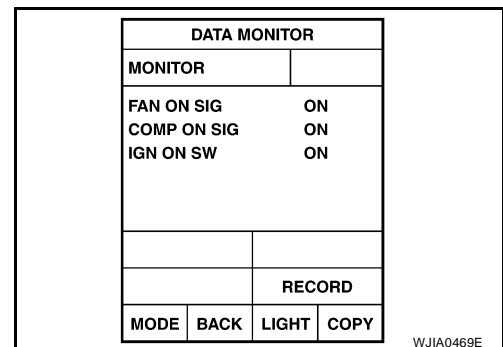

TROUBLE DIAGNOSIS

6. CHECK CIRCUIT CONTINUITY BETWEEN BCM AND FRONT AIR CONTROL

1. Turn ignition switch OFF.
2. Disconnect BCM connector and front air control connector.
3. Check continuity between BCM harness connector M18 (A) terminal 27 and front air control harness connector M49 (B) terminal 4.

Continuity should exist.

OK or NG

- OK >> GO TO 7.
 NG >> Repair harness or connector.

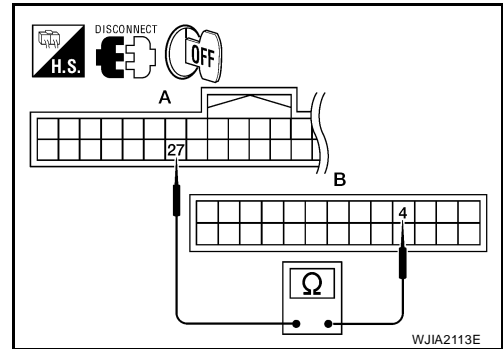

7. CHECK VOLTAGE FOR FRONT AIR CONTROL (COMPRESSOR ON SIGNAL)

1. Reconnect BCM connector and front air control connector.
2. Turn ignition switch ON.
3. Check voltage between front air control harness connector M49 terminal 4 and ground.

Terminals		(-)	Condition	Voltage (Approx.)
(+) Front air control connector				
Terminal No.				
M49	4	Ground	A/C switch: ON	0V
			A/C switch: OFF	5V

OK or NG

- OK >> GO TO 8.
 NG-1 >> If the voltage is approx. 5V when A/C switch is ON, replace front air control. Refer to [ATC-160, "FRONT AIR CONTROL"](#).
 NG-2 >> If the voltage is approx. 0V when A/C switch is OFF, replace BCM. Refer to [BCS-25, "Removal and Installation of BCM"](#).

8. CHECK REFRIGERANT PRESSURE SENSOR

1. Start engine.
2. Check voltage between ECM harness connector F54 terminal 70 and ground.

Terminals		(-)	Condition	Voltage (Approx.)
(+) ECM connector				
Terminal No.				
F54	70	Ground	A/C switch: ON	0.36 - 3.88V

OK or NG

- OK >> GO TO 9.
 NG >> Refer to [EC-704, "REFRIGERANT PRESSURE SENSOR"](#).

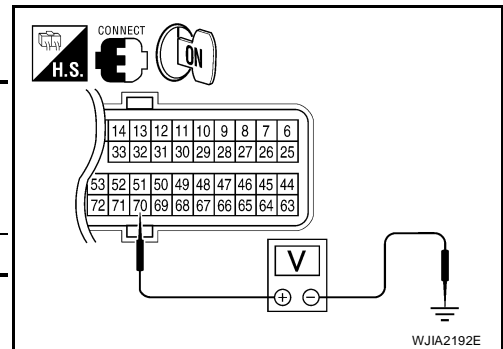

TROUBLE DIAGNOSIS

9. CHECK BCM INPUT (FAN ON) SIGNAL

Check FAN ON/OFF signal. Refer to [ATC-35, "CONSULT-II Function \(BCM\)"](#) .

FAN CONTROL SWITCH ON : FAN ON SIG ON
FAN CONTROL SWITCH OFF : FAN ON SIG OFF

OK or NG

OK >> GO TO 12.
 NG >> GO TO 10.

DATA MONITOR			
MONITOR			
FAN ON SIG	ON		
COMP ON SIG	ON		
IGN ON SW	ON		
		RECORD	
MODE	BACK	LIGHT	COPY

WJIA0469E

10. CHECK CIRCUIT CONTINUITY BETWEEN BCM AND FRONT AIR CONTROL

1. Turn ignition switch OFF.
2. Disconnect BCM connector and front air control connector.
3. Check continuity between BCM harness connector M18 (A) terminal 28 and front air control harness connector M49 (B) terminal 5.

Continuity should exist.

OK or NG

OK >> GO TO 11.
 NG >> Repair harness or connector.

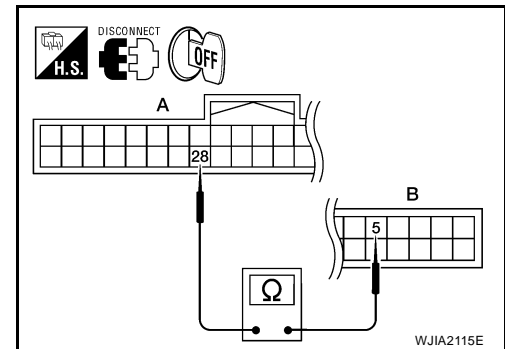

11. CHECK VOLTAGE FOR FRONT AIR CONTROL (FAN ON SIGNAL)

1. Reconnect BCM connector and front air control connector.
2. Turn ignition switch ON.
3. Check voltage between front air control harness connector M49 terminal 5 and ground.

Terminals		(-)	Condition	Voltage (Approx.)
(+)	Terminal No.			
Front air control connector				
M49	5	Ground	A/C switch: ON Blower motor operates	0V
			A/C switch: OFF	5V

OK or NG

- OK >> GO TO 12.
 NG-1 >> If the voltage is approx. 5V when blower motor is ON, replace front air control. Refer to [ATC-160, "FRONT AIR CONTROL"](#) .
 NG-2 >> If the voltage is approx. 0V when blower motor is OFF, replace BCM. Refer to [BCS-25, "Removal and Installation of BCM"](#) .

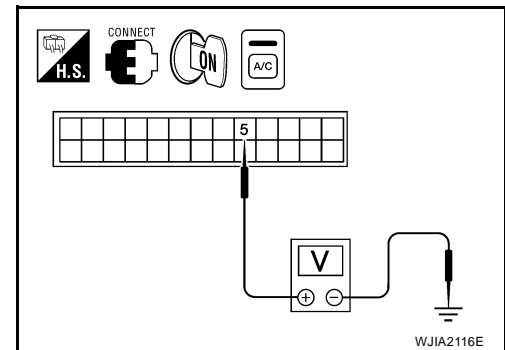

TROUBLE DIAGNOSIS

12. CHECK CAN COMMUNICATION

Check CAN communication. Refer to [ATC-31, "CAN Communication System Description"](#) .

- BCM – ECM
- ECM – IPDM E/R
- ECM – Front air control

OK or NG

OK >> Inspection End.

NG >> Repair or replace malfunctioning part(s).

A

B

C

D

E

F

G

H

I

ATC

K

L

M

TROUBLE DIAGNOSIS

EJS004KA

Insufficient Cooling

SYMPTOM: Insufficient cooling

INSPECTION FLOW

1. CONFIRM SYMPTOM BY PERFORMING OPERATIONAL CHECK - TEMPERATURE DECREASE

1. Press the AUTO switch.
2. Turn temperature control dial (driver) counterclockwise until 16° C (32° F) is displayed.
3. Check for cold air at discharge air outlets.

Can the symptom be duplicated?

- YES >> GO TO 3.
NO >> GO TO 2.

2. CHECK FOR ANY SYMPTOMS

Perform a complete operational check for any symptoms. Refer to [ATC-55, "Operational Check \(Front\)"](#) .

Does another symptom exist?

- YES >> Refer to [ATC-36, "SYMPTOM TABLE"](#) .
NO >> System OK.

3. CHECK FOR SERVICE BULLETINS

Check for any service bulletins.

>> GO TO 3.

4. PERFORM SELF-DIAGNOSIS

Perform self-diagnosis Refer to [ATC-53, "A/C System Self-diagnosis Function"](#) .

OK or NG

- OK >> GO TO 5.
NG >> Refer to [ATC-54, "SELF-DIAGNOSIS CODE CHART"](#) .

5. CHECK DRIVE BELTS

Check compressor belt tension. Refer to [EM-13, "Checking Drive Belts"](#) .

OK or NG

- OK >> GO TO 6.
NG >> Adjust or replace compressor belt. Refer to [EM-15, "Removal and Installation"](#) .

6. CHECK AIR MIX DOOR OPERATION

Check and verify air mix door mechanism for smooth operation.

Does air mix door operate correctly?

- YES >> GO TO 7.
NO >> Repair or replace air mix door control linkage.

7. CHECK COOLING FAN MOTOR OPERATION

Check and verify cooling fan motor for smooth operation. Refer to [EC-544, "Description"](#) .

Does cooling fan motor operate correctly?

- YES >> GO TO 8.
NO >> Check cooling fan motor. Refer to [EC-544, "DTC P1217 ENGINE OVER TEMPERATURE"](#) .

TROUBLE DIAGNOSIS

8. CHECK RECOVERY/RECYCLING EQUIPMENT BEFORE USAGE

Check recovery/recycling equipment before connecting to vehicle. Verify there is no pressure in the recovery/recycling equipment by checking the gauges. If pressure exists, recover refrigerant from equipment lines.

>> GO TO 9.

9. CHECK REFRIGERANT PURITY

1. Connect recovery/recycling equipment to vehicle.
2. Confirm refrigerant purity in supply tank using recovery/recycling and refrigerant identifier.

OK or NG

OK >> GO TO 10.

NG >> Check contaminated refrigerant. Refer to [ATC-5, "Contaminated Refrigerant"](#) .

10. CHECK FOR EVAPORATOR FREEZE UP

Start engine and run A/C. Check for evaporator freeze up.

Does evaporator freeze up?

YES >> Perform performance test diagnoses. Refer to [ATC-132, "PERFORMANCE TEST DIAGNOSES"](#) .

NO >> GO TO 11.

11. CHECK REFRIGERANT PRESSURE

Check refrigerant pressure with manifold gauge connected. Refer to [ATC-134, "Test Reading"](#) .

OK or NG

OK >> Perform performance test diagnoses. Refer to [ATC-132, "PERFORMANCE TEST DIAGNOSES"](#) .

NG >> GO TO 12.

12. CHECK AIR DUCTS

Check ducts for air leaks.

OK or NG

OK >> System OK.

NG >> Repair air leaks.

A

B

C

D

E

F

G

H

I

ATC

K

L

M

TROUBLE DIAGNOSIS

PERFORMANCE TEST DIAGNOSES

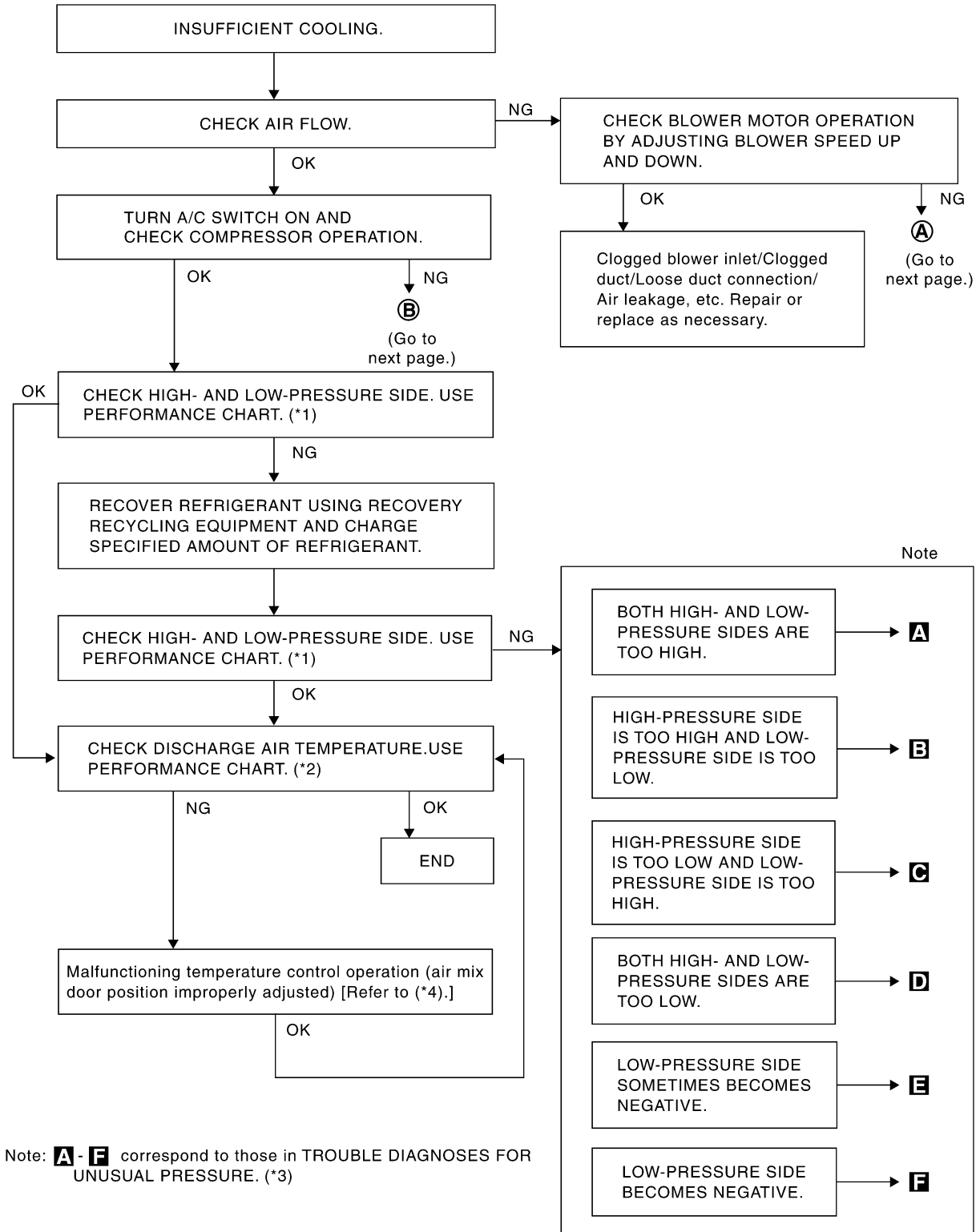

RJA1601E

*1 [ATC-134, "PERFORMANCE CHART"](#)

*2 [ATC-134, "PERFORMANCE CHART"](#)

*3 [ATC-135, "Trouble Diagnoses for Unusual Pressure"](#)

*4 [ATC-70, "Air Mix Door Motor Circuit"](#)

TROUBLE DIAGNOSIS

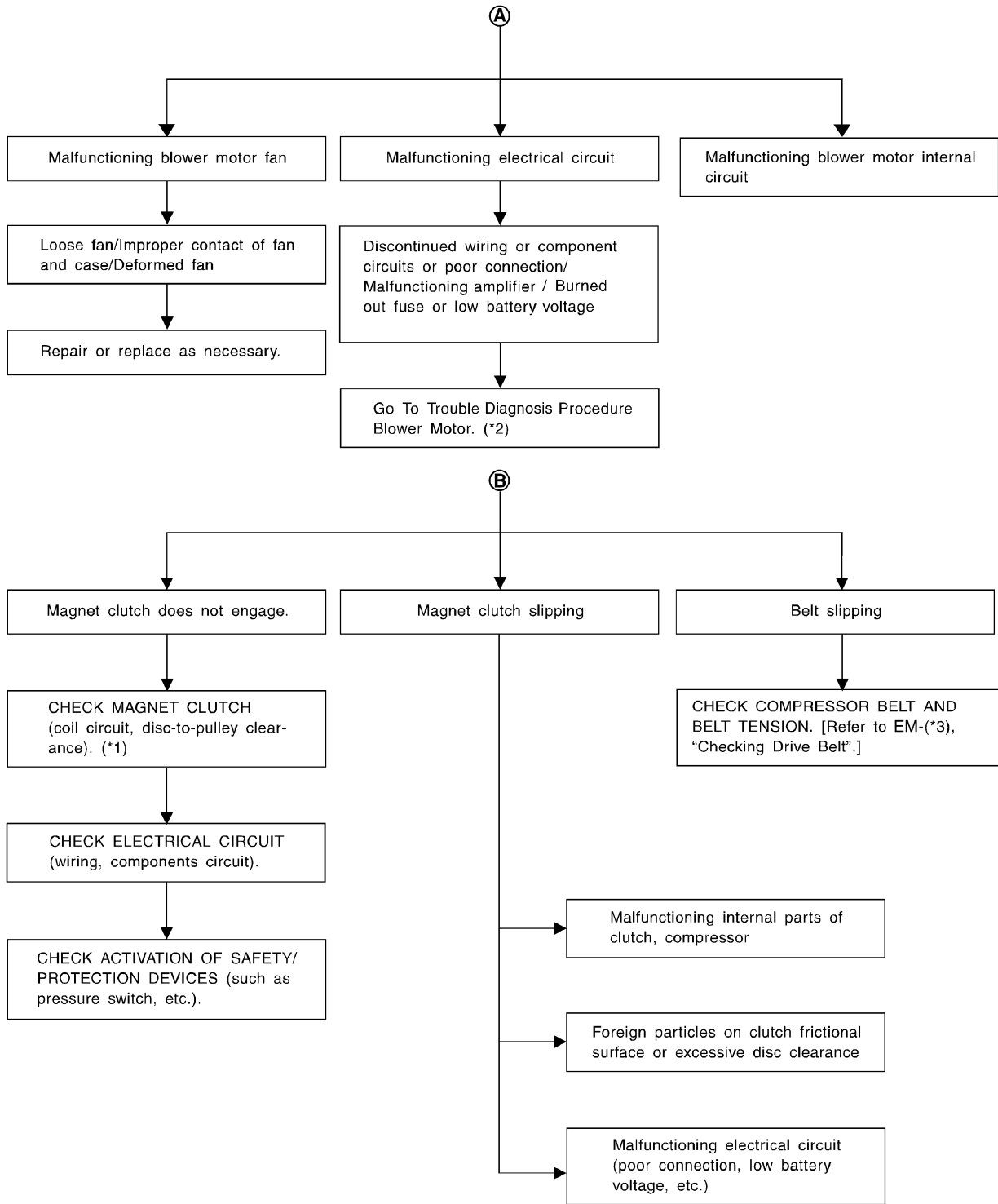

A
B
C
D
E
F
G
H
I
ATC
K
L
M

*1 [ATC-198, "Removal and Installation for Compressor Clutch"](#)

*2 [ATC-96, "Front Blower Motor Circuit"](#)

*3 [EM-13, "Checking Drive Belts"](#)



WJIA0361E

TROUBLE DIAGNOSIS

PERFORMANCE CHART

Test Condition

Testing must be performed as follows:

Vehicle location	Indoors or in the shade (in a well-ventilated place)
Doors	Closed
Windows	Open
Hood	Open
TEMP.	Max. COLD
Mode switch	 (Ventilation) set
Recirculation (REC) switch	 (Recirculation) set
 Blower speed (FR and RR)	Max. speed set
Engine speed	Idle speed
RR system	ON

Operate the air conditioning system for 10 minutes before taking measurements.

Test Reading

Recirculating-to-discharge Air Temperature Table

Inside air (Recirculating air) at blower assembly inlet		Discharge air temperature at center ventilator °C (°F)
Relative humidity %	Air temperature °C (°F)	
50-70	25 (77)	9.7 - 13.7 (49 - 57)
	30 (86)	12.6 - 16.6 (55 - 62)
	35 (95)	14.9 - 19.9 (59 - 68)
	40 (104)	17.3 - 23.3 (63 - 74)

Ambient Air Temperature-to-operating Pressure Table

Ambient air		High-pressure (Discharge side) kPa (kg/cm ² , psi)	Low-pressure (Suction side) kPa (kg/cm ² , psi)
Relative humidity %	Air temperature °C (°F)		
50-70	25 (77)	1,059 - 1,294 (10.8 - 13.2, 153.6 - 187.7)	216 - 255 (2.2 - 2.6, 31.3 - 37.0)
	30 (86)	1,206 - 1,481 (12.3 - 15.1, 174.9 - 214.8)	255 - 304 (2.6 - 3.1, 37.0 - 44.1)
	35 (95)	1,393 - 1,706 (14.2 - 17.4, 202.0 - 247.5)	275 - 343 (2.8 - 3.5, 39.8 - 49.8)
	40 (104)	1,510 - 1,844 (15.4 - 18.8, 219.0 - 267.4)	343 - 422 (3.5 - 4.3, 49.8 - 61.2)

TROUBLE DIAGNOSIS

TROUBLE DIAGNOSES FOR UNUSUAL PRESSURE

Whenever system's high and/or low side pressure is unusual, diagnose using a manifold gauge. The marker above the gauge scale in the following tables indicates the standard (usual) pressure range. Since the standard (usual) pressure, however, differs from vehicle to vehicle, refer to above table (Ambient air temperature-to-operating pressure table).

Both High- and Low-pressure Sides are Too High

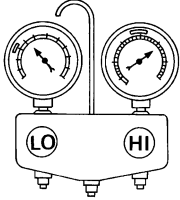
Gauge indication	Refrigerant cycle	Probable cause	Corrective action
<p>Both high- and low-pressure sides are too high.</p>  <p style="text-align: right; font-size: small;">AC359A</p>	<p>Pressure is reduced soon after water is splashed on condenser.</p>	<p>Excessive refrigerant charge in refrigeration cycle</p>	<p>Reduce refrigerant until specified pressure is obtained.</p>
	<p>Air suction by cooling fan is insufficient.</p>	<p>Insufficient condenser cooling performance ↓ 1. Condenser fins are clogged. 2. Improper fan rotation of cooling fan</p>	<ul style="list-style-type: none"> ● Clean condenser. ● Check and repair cooling fan as necessary.
	<ul style="list-style-type: none"> ● Low-pressure pipe is not cold. ● When compressor is stopped high-pressure value quickly drops by approximately 196 kPa (2 kg/cm², 28 psi). It then decreases gradually thereafter. 	<p>Poor heat exchange in condenser (After compressor operation stops, high-pressure decreases too slowly.) ↓ Air in refrigeration cycle</p>	<p>Evacuate and recharge system.</p>
	<p>Engine tends to overheat.</p>	<p>Engine cooling systems malfunction.</p>	<p>Check and repair engine cooling system.</p>
	<ul style="list-style-type: none"> ● An area of the low-pressure pipe is colder than areas near the evaporator outlet. ● Plates are sometimes covered with frost. 	<ul style="list-style-type: none"> ● Excessive liquid refrigerant on low-pressure side ● Excessive refrigerant discharge flow ● Expansion valve is open a little compared with the specification. <p>↓ Improper expansion valve adjustment</p>	<p>Replace expansion valve.</p>

High-pressure Side is Too High and Low-pressure Side is Too Low

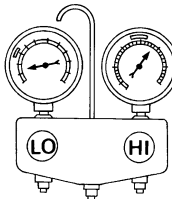
Gauge indication	Refrigerant cycle	Probable cause	Corrective action
<p>High-pressure side is too high and low-pressure side is too low.</p>  <p style="text-align: right; font-size: small;">AC360A</p>	<p>Upper side of condenser and high-pressure side are hot, however, liquid tank is not so hot.</p>	<p>High-pressure tube or parts located between compressor and condenser are clogged or crushed.</p>	<ul style="list-style-type: none"> ● Check and repair or replace malfunctioning parts. ● Check oil for contamination.

TROUBLE DIAGNOSIS

High-pressure Side is Too Low and Low-pressure Side is Too High

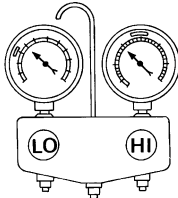
Gauge indication	Refrigerant cycle	Probable cause	Corrective action
High-pressure side is too low and low-pressure side is too high.  AC356A	High- and low-pressure sides become equal soon after compressor operation stops.	Compressor pressure operation is improper. ↓ Damaged inside compressor packings.	Replace compressor.
	No temperature difference between high- and low-pressure sides.	Compressor pressure operation is improper. ↓ Damaged inside compressor packings.	Replace compressor.

Both High- and Low-pressure Sides are Too Low

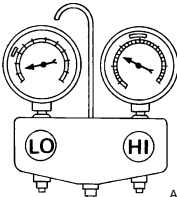
Gauge indication	Refrigerant cycle	Probable cause	Corrective action
Both high- and low-pressure sides are too low.  AC353A	<ul style="list-style-type: none"> There is a big temperature difference between liquid tank outlet and inlet. Outlet temperature is extremely low. Liquid tank inlet and expansion valve are frosted. 	Liquid tank inside is slightly clogged.	<ul style="list-style-type: none"> Replace liquid tank. Check oil for contamination.
	<ul style="list-style-type: none"> Temperature of expansion valve inlet is extremely low as compared with areas near liquid tank. Expansion valve inlet may be frosted. Temperature difference occurs somewhere in high-pressure side. 	High-pressure pipe located between liquid tank and expansion valve is clogged.	<ul style="list-style-type: none"> Check and repair malfunctioning parts. Check oil for contamination.
	Expansion valve and liquid tank are warm or only cool when touched.	Low refrigerant charge. ↓ Leaking fittings or components.	Check refrigerant system for leaks. Refer to ATC-212, "Checking for Refrigerant Leaks" .
	There is a big temperature difference between expansion valve inlet and outlet while the valve itself is frosted.	Expansion valve closes a little compared with the specification. ↓ 1. Improper expansion valve adjustment. 2. Malfunctioning expansion valve. 3. Outlet and inlet may be clogged.	<ul style="list-style-type: none"> Remove foreign particles by using compressed air. Check oil for contamination.
	An area of the low-pressure pipe is colder than areas near the evaporator outlet.	Low-pressure pipe is clogged or crushed.	<ul style="list-style-type: none"> Check and repair malfunctioning parts. Check oil for contamination.
	Air flow volume is too low.	Evaporator is frozen.	<ul style="list-style-type: none"> Check intake sensor circuit. Refer to ATC-158, "Intake Sensor Circuit". Replace compressor.

TROUBLE DIAGNOSIS

Low-pressure Side Sometimes Becomes Negative

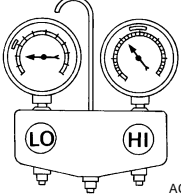
Gauge indication	Refrigerant cycle	Probable cause	Corrective action
<p>Low-pressure side sometimes becomes negative.</p>  <p style="text-align: right; font-size: small;">AC354A</p>	<ul style="list-style-type: none"> ● Air conditioning system does not function and does not cyclically cool the compartment air. ● The system constantly functions for a certain period of time after compressor is stopped and restarted. 	<p>Refrigerant does not discharge cyclically.</p> <p>↓</p> <p>Moisture is frozen at expansion valve outlet and inlet.</p> <p>↓</p> <p>Water is mixed with refrigerant.</p>	<ul style="list-style-type: none"> ● Drain water from refrigerant or replace refrigerant. ● Replace liquid tank.

A
B
C
D

Low-pressure Side Becomes Negative

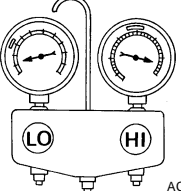
Gauge indication	Refrigerant cycle	Probable cause	Corrective action
<p>Low-pressure side becomes negative.</p>  <p style="text-align: right; font-size: small;">AC362A</p>	<p>Liquid tank or front/rear side of expansion valve's pipe is frosted or dewed.</p>	<p>High-pressure side is closed and refrigerant does not flow.</p> <p>↓</p> <p>Expansion valve or liquid tank is frosted.</p>	<p>Leave the system at rest until no frost is present. Start it again to check whether or not the malfunction is caused by water or foreign particles.</p> <ul style="list-style-type: none"> ● If water is the cause, initially cooling is okay. Then the water freezes causing a blockage. Drain water from refrigerant or replace refrigerant. ● If due to foreign particles, remove expansion valve and remove the particles with dry and compressed air (not shop air). ● If either of the above methods cannot correct the malfunction, replace expansion valve. ● Replace liquid tank. ● Check oil for contamination.

E
F
G
H
I

ATC

K
L
M

TROUBLE DIAGNOSIS

EJS004KB

Insufficient Heating

SYMPTOM: Insufficient heating

INSPECTION FLOW

1. CONFIRM SYMPTOM BY PERFORMING OPERATIONAL CHECK - TEMPERATURE INCREASE

1. Press the AUTO switch.
2. Turn the temperature control dial (driver) clockwise until 32° C (90° F) is displayed.
3. Check for hot air at discharge air outlets.

Can this symptom be duplicated?

YES >> GO TO 2.

NO >> Perform complete system operational check. Refer to [ATC-55, "Operational Check \(Front\)"](#) .

2. CHECK FOR SERVICE BULLETINS

Check for any service bulletins.

>> GO TO 3.

3. PERFORM SELF-DIAGNOSIS

Perform self-diagnosis. Refer to [ATC-53, "A/C System Self-diagnosis Function"](#) .

OK or NG

OK >> GO TO 4.

NG >> Refer to [ATC-54, "SELF-DIAGNOSIS CODE CHART"](#) .

4. CHECK ENGINE COOLING SYSTEM

1. Check for proper engine coolant level. Refer to [CO-9, "CHECKING RESERVOIR LEVEL"](#) .
2. Check hoses for leaks or kinks.
3. Check radiator cap. Refer to [CO-9, "CHECKING RADIATOR CAP"](#) .
4. Check for air in cooling system.

>> GO TO 5.

5. CHECK HEATER PUMP

1. Rotate temperature control dial to full hot 32°C (90°F).
2. Rotate fan control dial counterclockwise to maximum speed.
3. Heater pump should be activated.

OK or NG

OK >> GO TO 6.

NG >> Check heater pump circuit. Refer to [ATC-140, "Heater Pump Circuit"](#) .

6. CHECK AIR MIX DOOR OPERATION

Check the operation of the air mix door.

OK or NG

OK >> GO TO 7.

NG >> Check the air mix door motor circuit. Refer to [ATC-70, "Air Mix Door Motor Circuit"](#) .

TROUBLE DIAGNOSIS

7. CHECK AIR DUCTS

Check for disconnected or leaking air ducts.

OK or NG

- OK >> GO TO 8.
- NG >> Repair all disconnected or leaking air ducts.

8. CHECK HEATER HOSE TEMPERATURES

1. Start engine and warm it up to normal operating temperature.
2. Touch both the inlet and outlet heater hoses.

OK or NG

- OK >> Hot inlet hose and a warm outlet hose: GO TO 9.
- NG >> Both hoses warm: GO TO 10.

9. CHECK ENGINE COOLANT SYSTEM

Check engine control temperature sensor. Refer to [EC-216, "DTC P0117, P0118 ECT SENSOR"](#) .

OK or NG

- OK >> System OK.
- NG >> Repair or replace as necessary. Retest.

10. CHECK HEATER HOSES

Check heater hoses for proper installation.

OK or NG

- OK >> System OK.
- NG >> 1. Back flush heater core.
2. Drain the water from the system.
3. Refill system with new engine coolant. Refer to [MA-13, "Changing Engine Coolant"](#) .
4. GO TO 11 to retest.

11. CHECK HEATER HOSE TEMPERATURES

1. Start engine and warm it up to normal operating temperature.
2. Touch both the inlet and outlet heater hoses.

OK or NG

- OK >> System OK.
- NG >> Replace heater core. Refer to [ATC-172, "HEATER CORE"](#) .

A
B
C
D
E
F
G
H
I
K
L
M

ATC

TROUBLE DIAGNOSIS

EJS004TM

Heater Pump Circuit SYSTEM DESCRIPTION

Component Parts

Heater pump control system components are:

- Front air control
- Heater pump relay
- Heater pump
- Intake sensor

System Operation

The heater pump improves heater performance specifically at idle conditions. It is designed to operate in either of the following 2 situations:

1. Front blower motor set to maximum speed and temperature control dial (driver or passenger) set to full hot 32° C (90° F) or
2. Engine coolant temperature (signal via CAN communication) minus heater core outlet temperature (intake sensor input to front air control) is greater than 20° C (68° F). If the difference is less than 16° C (61° F), the heater pump will not operate unless the conditions in item No. 1 above are met.

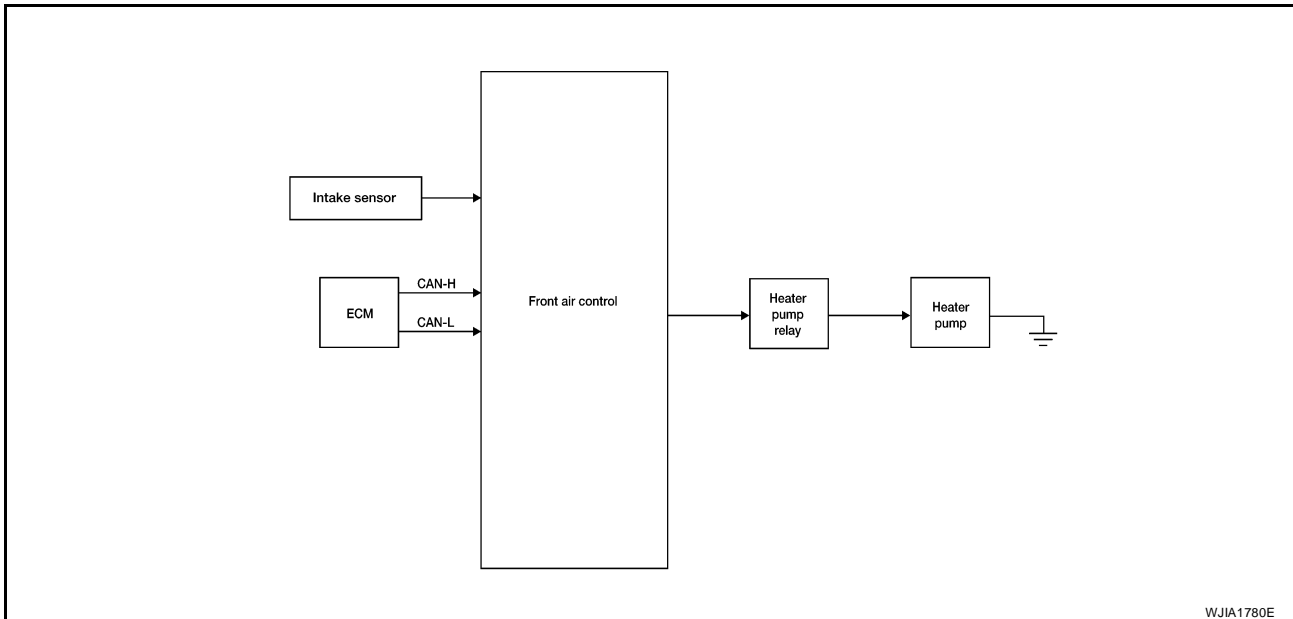

WJIA1780E

TROUBLE DIAGNOSIS

DIAGNOSTIC PROCEDURE FOR HEATER PUMP CIRCUIT

1. CHECK POWER SUPPLY TO HEATER PUMP

1. Disconnect heater pump connector.
2. Turn ignition switch ON.
3. Set front blower motor to maximum speed.
4. Turn temperature control dial (passenger or driver) to full hot 32° C (90° F).
5. Check voltage between heater pump harness connector E127 terminal 1 and ground.

(1) - Ground : Battery voltage

OK or NG

- OK >> GO TO 2.
NG >> GO TO 3.

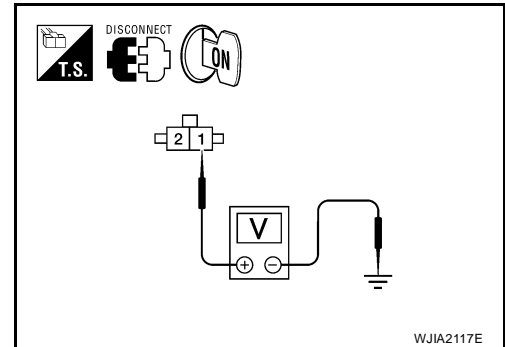

2. CHECK HEATER PUMP GROUND

1. Turn ignition switch OFF.
2. Check continuity between heater pump harness connector E127 terminal 2 and ground.

2 - Ground : Continuity should exist.

OK or NG

- OK >> Replace heater pump. Refer to [ATC-175, "HEATER PUMP"](#).
- NG >> Repair harness or connector.

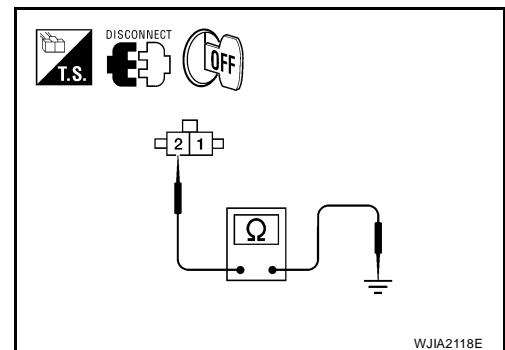

3. CHECK HEATER PUMP RELAY

1. Turn ignition switch OFF.
2. Check heater pump relay. Refer to [ATC-142, "Heater Pump Relay"](#).

OK or NG

- OK >> GO TO 4.
NG >> Replace heater pump relay.

4. CHECK RELAY POWER SUPPLY

1. Turn ignition switch ON.
2. Check voltage between heater pump relay harness connector E128 terminals 1, 5 and ground.

1 - Ground : Battery voltage

5 - Ground : Battery voltage

OK or NG

- OK >> GO TO 5.
NG >> Repair harness or connector.

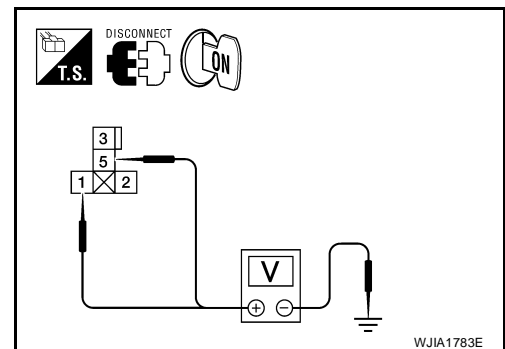

TROUBLE DIAGNOSIS

5. CHECK HEATER PUMP MOTOR POWER CIRCUIT

1. Turn ignition switch OFF.
2. Check continuity between heater pump relay harness connector E128 (A) terminal 3 and heater pump harness connector E127 (B) terminal 1.

3 - 1 : Continuity should exist.

3. Check continuity between heater pump relay harness connector E128 (A) terminal 3 and ground.

3 - Ground : Continuity should not exist.

OK or NG

OK >> GO TO 6.

NG >> Repair harness or connector.

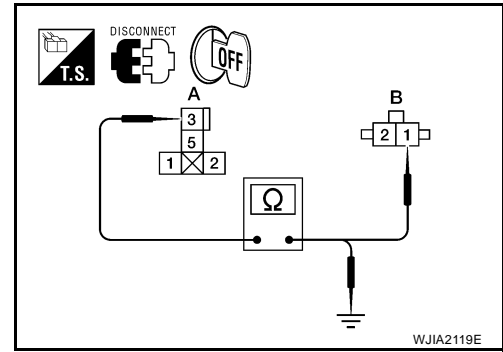

6. CHECK CIRCUIT BETWEEN HEATER PUMP RELAY AND FRONT AIR CONTROL

1. Disconnect front air control connector.
2. Check continuity between front air control harness connector M49 (A) terminal 10 and heater pump relay harness connector E128 (B) terminal 2.

2 - 10 : Continuity should exist.

3. Check continuity between heater pump relay harness connector E128 (B) terminal 2 and ground.

2 - Ground : Continuity should not exist.

OK or NG

OK >> Replace front air control. Refer to [ATC-160, "FRONT AIR CONTROL"](#).

NG >> Repair harness or connector.

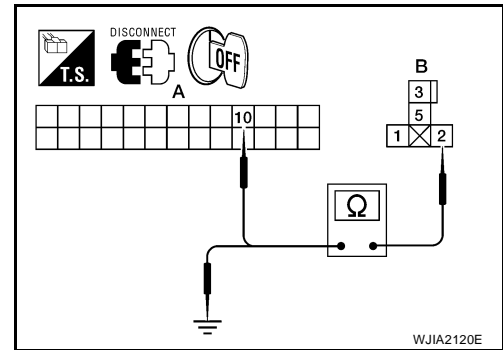

COMPONENT INSPECTION

Heater Pump Relay

Check continuity between terminals 3 and 5.

Conditions	Continuity
12V direct current supply between terminals 1 and 2	Yes
No current supply	No

If NG, replace relay.

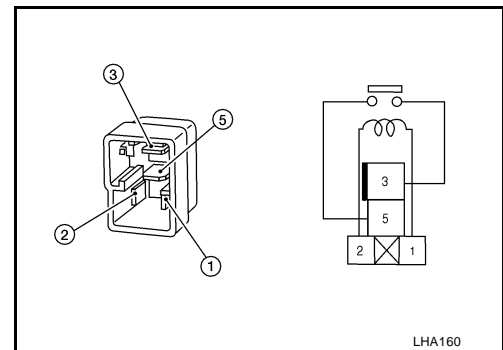

TROUBLE DIAGNOSIS

EJS004KC

Noise

SYMPTOM: Noise

INSPECTION FLOW

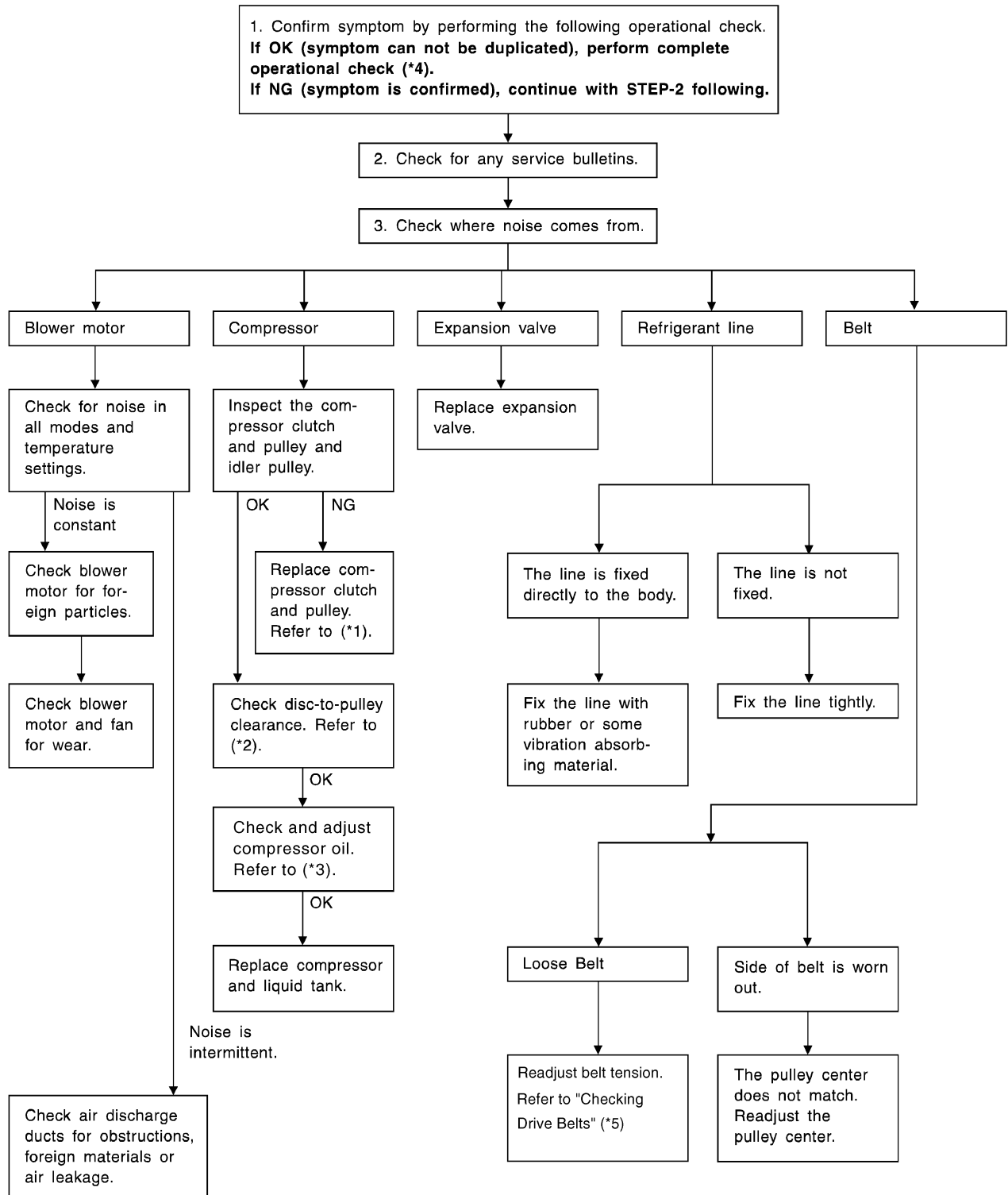

A
B
C
D
E
F
G
H
I
K
L
M

ATC

TROUBLE DIAGNOSIS

*1 [ATC-198, "REMOVAL"](#)

*2 [ATC-199, "INSTALLATION"](#)

*3 [ATC-22, "Maintenance of Oil Quantity in Compressor"](#)

*4 [ATC-55, "Operational Check \(Front\)"](#)

*5 [EM-13, "Checking Drive Belts"](#)

TROUBLE DIAGNOSIS

EJS004KD

Self-diagnosis

SYMPTOM: Self-diagnosis cannot be performed.

INSPECTION FLOW

1. CONFIRM AUTO MODE OPERATION

1. Press the AUTO switch.
2. Display should indicate AUTO. (Discharge air and blower speed will depend on ambient, in-vehicle and set temperatures.)

OK or NG

- OK >> GO TO 2.
- NG >> GO TO 3.

2. PERFORM COMPLETE OPERATIONAL CHECK (FRONT)

Perform a complete operational check and check for any symptoms. Refer to [ATC-55, "Operational Check \(Front\)"](#) .

Can a symptom be duplicated?

- YES >> Refer to [MTC-35, "SYMPTOM TABLE"](#) .
- NO >> System OK.

3. CHECK FOR SERVICE BULLETINS

Check for any service bulletins.

Have any service bulletins been issued?

- YES >> Refer to appropriate service bulletin.
- NO >> GO TO 4.

4. CHECK POWER AND GROUND CIRCUIT

Check main power supply and ground circuit. Refer to [ATC-60, "DIAGNOSTIC PROCEDURE FOR A/C SYSTEM"](#) .

OK or NG

- OK >> GO TO 5.
- NG >> Refer to [MTC-57, "Power Supply and Ground Circuit for Front Air Control"](#) .

5. CHECK AMBIENT SENSOR CIRCUIT

Check ambient sensor circuit. Refer to [ATC-148, "Ambient Sensor Circuit"](#) .

OK or NG

- OK >> GO TO 6.
- NG >> Repair or replace as necessary.

6. CHECK IN-VEHICLE SENSOR CIRCUIT

Check in-vehicle sensor circuit. Refer to [ATC-151, "In-vehicle Sensor Circuit"](#) .

OK or NG

- OK >> GO TO 7.
- NG >> Repair or replace as necessary.

7. CHECK OPTICAL SENSOR CIRCUIT

Check optical sensor circuit. Refer to [ATC-155, "Optical Sensor Circuit"](#) .

OK or NG

- OK >> GO TO 8.
- NG >> Repair or replace as necessary.

A

B

C

D

E

F

G

H

I

ATC

K

L

M

TROUBLE DIAGNOSIS

8. CHECK INTAKE SENSOR CIRCUIT

Check intake sensor circuit. Refer to [ATC-158, "Intake Sensor Circuit"](#) .

OK or NG

OK >> GO TO 9.

NG >> Repair or replace as necessary.

9. CHECK AIR MIX DOOR MOTORS PBR CIRCUIT

Check air mix door motors PBR circuit. Refer to [ATC-70, "Air Mix Door Motor Circuit"](#) .

OK or NG

OK >> GO TO 10.

NG >> Repair or replace as necessary.

10. RECHECK FOR SYMPTOMS

Perform a complete operational check for any symptoms. Refer to [ATC-55, "Operational Check \(Front\)"](#) .

Does another symptom exist?

YES >> Refer to [ATC-36, "SYMPTOM TABLE"](#) .

NO >> Replace front air control. Refer to [ATC-160, "FRONT AIR CONTROL"](#) .

TROUBLE DIAGNOSIS

EJS004KE

Memory Function

SYMPTOM: Memory function does not operate.

INSPECTION FLOW

1. CONFIRM SYMPTOM BY PERFORMING OPERATIONAL CHECK - MEMORY FUNCTION

1. Set the temperature to 32°C (90°F).
2. Press the OFF switch.
3. Turn ignition switch OFF.
4. Turn ignition switch ON.
5. Press the AUTO switch.
6. Confirm that the set temperature remains at previous temperature.
7. Press OFF switch.

Can the symptom be duplicated?

- YES >> GO TO 3.
NO >> GO TO 2.

2. PERFORM COMPLETE OPERATIONAL CHECK

Perform a complete operational check and check for any symptoms. Refer to [ATC-55, "Operational Check \(Front\)"](#).

Can a symptom be duplicated?

- YES >> Refer to [ATC-36, "SYMPTOM TABLE"](#).
NO >> System OK.

3. CHECK FOR SERVICE BULLETINS

Check for any service bulletins.

>> GO TO 4.

4. PERFORM SELF-DIAGNOSIS

Perform self-diagnosis to check for any codes. Refer to [ATC-53, "A/C System Self-diagnosis Function"](#).

Are any self-diagnosis codes present?

- YES >> Refer to [ATC-54, "SELF-DIAGNOSIS CODE CHART"](#).
NO >> GO TO 5.

5. CHECK POWER AND GROUND CIRCUIT

Check main power supply and ground circuit. Refer to [ATC-60, "DIAGNOSTIC PROCEDURE FOR A/C SYSTEM"](#).

>> GO TO 6.

6. RECHECK FOR SYMPTOMS

Perform a complete operational check for any symptoms. Refer to [ATC-55, "Operational Check \(Front\)"](#).

Does another symptom exist?

- YES >> Refer to [ATC-36, "SYMPTOM TABLE"](#).
NO >> Replace front air control. Refer to [ATC-160, "FRONT AIR CONTROL"](#).

A

B

C

D

E

F

G

H

I

ATC

K

L

M

TROUBLE DIAGNOSIS

EJS004KF

Ambient Sensor Circuit COMPONENT DESCRIPTION

Ambient Sensor

The ambient sensor is attached on the radiator core support (driver side). It detects ambient temperature and converts it into a resistance value which is then input into the front air control.

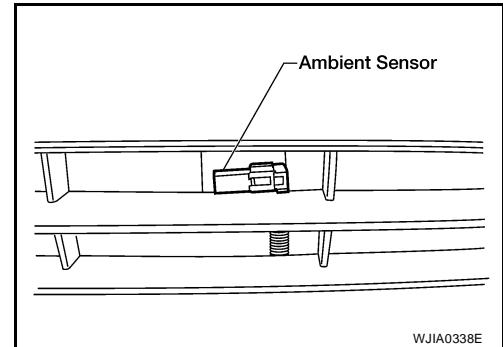

AMBIENT TEMPERATURE INPUT PROCESS

The front air control includes a processing circuit for the ambient sensor input. However, when the temperature detected by the ambient sensor increases quickly, the processing circuit retards the front air control function. It only allows the front air control to recognize an ambient temperature increase of 0.33°C (0.6°F) per 100 seconds.

This prevents constant adjustments due to momentary conditions, such as stopping after high speed driving. Although the actual ambient temperature has not changed, the temperature detected by the ambient sensor will increase. This is because the heat from the engine compartment can radiate to the front grille area, location of the ambient sensor.

DIAGNOSTIC PROCEDURE FOR AMBIENT SENSOR

SYMPTOM: Ambient sensor circuit is open or shorted. Using the CONSULT-II, DTC B257B or B257C is displayed. Without a CONSULT-II, code 40 or 41 is indicated on front air control as a result of conducting the front air control self-diagnosis.

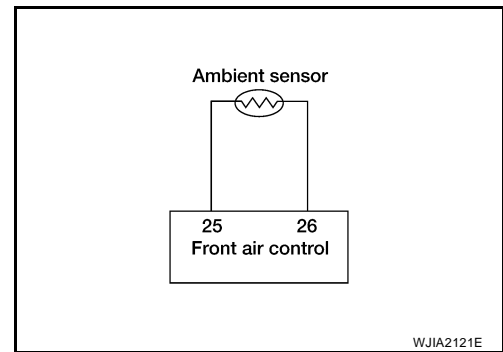

1. CHECK VOLTAGE BETWEEN AMBIENT SENSOR AND GROUND

1. Disconnect ambient sensor connector.
2. Turn ignition switch ON.
3. Check voltage between ambient sensor harness connector E1 terminal 1 and ground.

Approx. 5V

OK or NG

- OK >> GO TO 2.
NG >> GO TO 4.

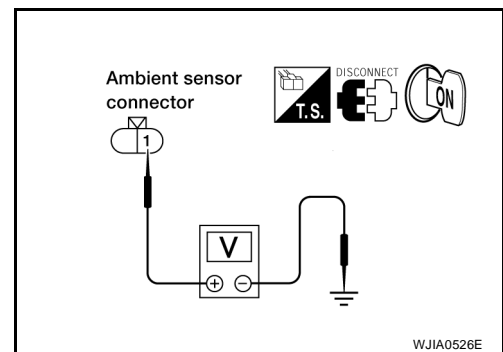

TROUBLE DIAGNOSIS

2. CHECK CIRCUIT CONTINUITY BETWEEN AMBIENT SENSOR AND FRONT AIR CONTROL

1. Turn ignition switch OFF.
2. Disconnect front air control connector.
3. Check continuity between ambient sensor harness connector E1 (B) terminal 2 and front air control harness connector M49 (A) terminal 25.

Continuity should exist.

OK or NG

- OK >> GO TO 3.
NG >> Repair harness or connector.

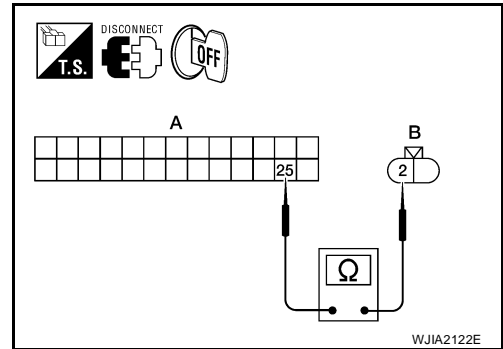

3. CHECK AMBIENT SENSOR

Check ambient sensor. Refer to [ATC-150, "Ambient Sensor"](#) .

OK or NG

- OK >> 1. Replace front air control. Refer to [ATC-160, "FRONT AIR CONTROL"](#) .
2. Go to [ATC-53, "A/C System Self-diagnosis Function"](#) and perform self-diagnosis.
- NG >> 1. Replace ambient sensor. [ATC-162, "AMBIENT SENSOR"](#) .
2. Go to [ATC-53, "A/C System Self-diagnosis Function"](#) and perform self-diagnosis.

4. CHECK CIRCUIT CONTINUITY BETWEEN AMBIENT SENSOR AND FRONT AIR CONTROL

1. Turn ignition switch OFF.
2. Disconnect front air control connector.
3. Check continuity between ambient sensor harness connector E1 (B) terminal 1 and front air control harness connector M49 (A) terminal 26.

Continuity should exist.

4. Check continuity between ambient sensor harness connector E1 terminal 1 and ground.

Continuity should not exist.

OK or NG

- OK >> 1. Replace front air control. Refer to [ATC-160, "FRONT AIR CONTROL"](#) .
2. Go to [ATC-53, "A/C System Self-diagnosis Function"](#) and perform self-diagnosis.
- NG >> Repair harness or connector.

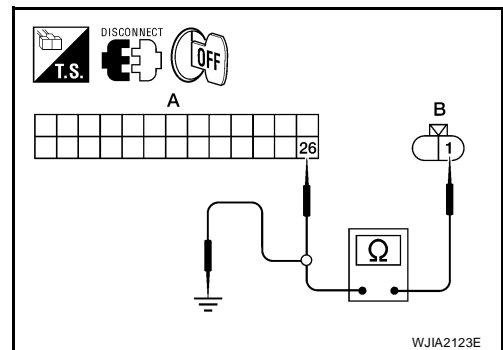

TROUBLE DIAGNOSIS

COMPONENT INSPECTION

Ambient Sensor

After disconnecting ambient sensor connector, measure resistance between terminals 2 and 1 at sensor component side, using the table below.

Temperature °C (°F)	Resistance kΩ
-15 (5)	12.73
-10 (14)	9.92
-5 (23)	7.80
0 (32)	6.19
5 (41)	4.95
10 (50)	3.99
15 (59)	3.24
20 (68)	2.65
25 (77)	2.19
30 (86)	1.81
35 (95)	1.51
40 (104)	1.27
45 (113)	1.07

If NG, replace ambient sensor.

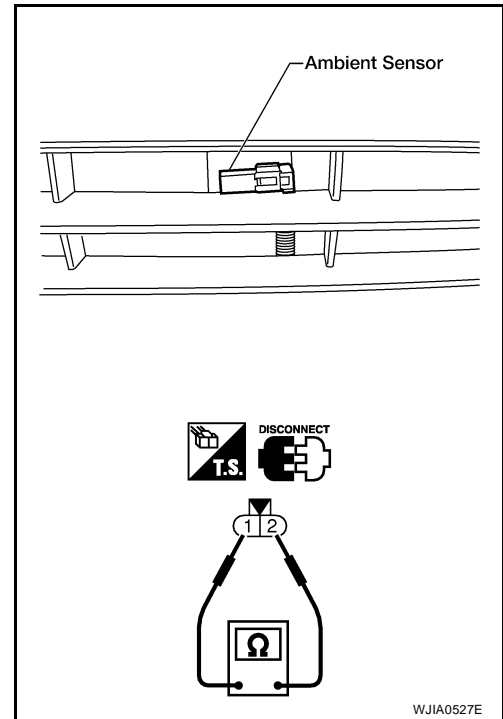

WJIA0527E

TROUBLE DIAGNOSIS

In-vehicle Sensor Circuit COMPONENT DESCRIPTION

EJS004KG

In-vehicle Sensor

The in-vehicle sensor (1) is located on instrument lower driver panel. It converts variations in temperature of passenger compartment air (drawn in through the integrated fan) into a value. It is then input into the front air control.

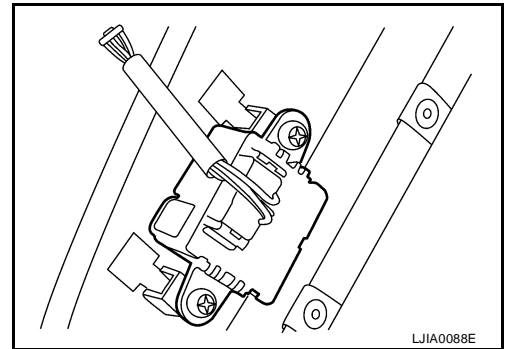
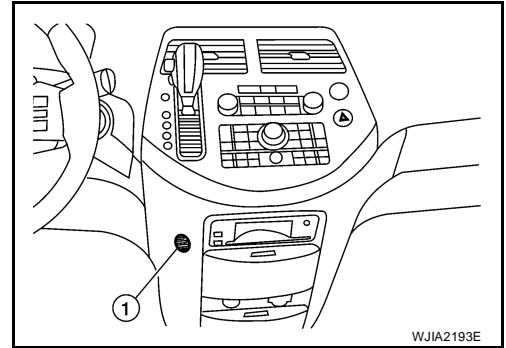

A
B
C
D
E
F
G
H
I

ATC

K
L
M

TROUBLE DIAGNOSIS

DIAGNOSTIC PROCEDURE FOR IN-VEHICLE SENSOR

SYMPTOM: In-vehicle sensor circuit is open or shorted. Using the CONSULT-II, DTC B2578 or B2579 is displayed. Without a CONSULT-II, code 30 or 31 is indicated on front air control as a result of conducting the front air control self-diagnosis.

SYMPTOM: In-vehicle sensor motor circuit is open or shorted. Using the CONSULT-II, DTC B2570 or B257E is displayed. Without a CONSULT-II, code 44 or 46 is indicated on front air control as a result of conducting the front air control self-diagnosis

1. CHECK VOLTAGE BETWEEN IN-VEHICLE SENSOR AND GROUND

Self-diagnosis DTC B2578 or B2579 (with CONSULT-II) or code 30 or 31 (without CONSULT-II) is present. Refer to [ATC-32, "Display Item List"](#) .

Yes or No

- Yes >> GO TO 2.
- No >> GO TO 7.

2. CHECK IN-VEHICLE SENSOR RETURN VOLTAGE

1. Disconnect in-vehicle sensor connector.
2. Turn ignition switch ON.
3. Check voltage between in-vehicle sensor harness connector M32 terminal 4 and ground.

Approx. 5V.

OK or NG

- OK >> GO TO 3.
- NG >> GO TO 5.

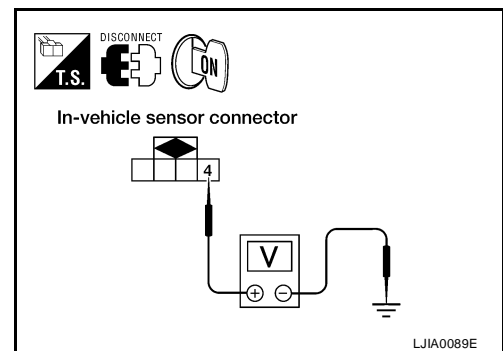

3. CHECK IN-VEHICLE SENSOR VOLTAGE

Check voltage between in-vehicle sensor harness connector M32 terminal 1 and ground.

Approx. 5V.

OK or NG

- OK >> GO TO 4.
- NG >> GO TO 6.

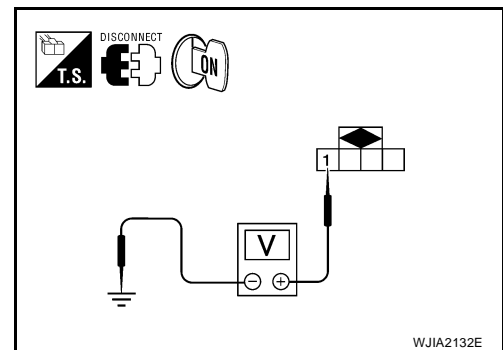

4. CHECK IN-VEHICLE SENSOR

Check in-vehicle sensor. Refer to [ATC-154, "In-vehicle Sensor"](#) .

OK or NG

- OK >> 1. Replace front air control. Refer to [ATC-160, "FRONT AIR CONTROL"](#) .
2. Go to [ATC-53, "A/C System Self-diagnosis Function"](#) and perform self-diagnosis.
- NG >> 1. Replace in-vehicle sensor.
2. Go to [ATC-53, "A/C System Self-diagnosis Function"](#) and perform self-diagnosis.

TROUBLE DIAGNOSIS

5. CHECK CIRCUIT CONTINUITY BETWEEN IN-VEHICLE SENSOR AND FRONT AIR CONTROL

1. Turn ignition switch OFF.
2. Disconnect front air control connector.
3. Check continuity between in-vehicle sensor harness connector M32 (B) terminal 4 and front air control harness connector M49 (A) terminal 26.

Continuity should exist.

4. Check continuity between in-vehicle sensor harness connector M32 terminal 4 and ground.

Continuity should not exist.

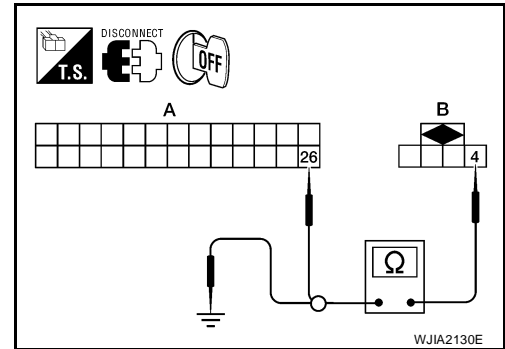

OK or NG

- OK >> 1. Replace front air control. Refer to [ATC-160, "FRONT AIR CONTROL"](#) .
2. Go to self-diagnosis [ATC-53, "A/C System Self-diagnosis Function"](#) and perform self-diagnosis.
- NG >> Repair harness or connector.

6. CHECK CIRCUIT CONTINUITY BETWEEN IN-VEHICLE SENSOR AND FRONT AIR CONTROL

1. Turn ignition switch OFF.
2. Disconnect front air control connector.
3. Check continuity between in-vehicle sensor harness connector M32 (B) terminal 1 and front air control harness connector M50 (A) terminal 32.

Continuity should exist.

4. Check continuity between in-vehicle sensor harness connector M32 terminal 1 and ground.

Continuity should not exist.

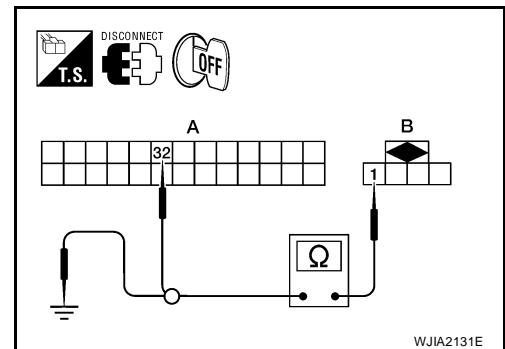

OK or NG

- OK >> 1. Replace front air control. Refer to [ATC-160, "FRONT AIR CONTROL"](#) .
2. Go to self-diagnosis [ATC-53, "A/C System Self-diagnosis Function"](#) and perform self-diagnosis.
- NG >> Repair harness or connector.

7. CHECK IN-VEHICLE SENSOR MOTOR VOLTAGE (SELF-DIAGNOSIS CODES 44 OR 46)

1. Turn ignition switch OFF.
2. Disconnect in-vehicle sensor connector.
3. Turn ignition switch ON.
4. Check voltage between in-vehicle sensor harness connector M32 terminal 3 and ground.

Battery voltage should exist.

OK or NG

- OK >> GO TO 8.
NG >> GO TO 9.

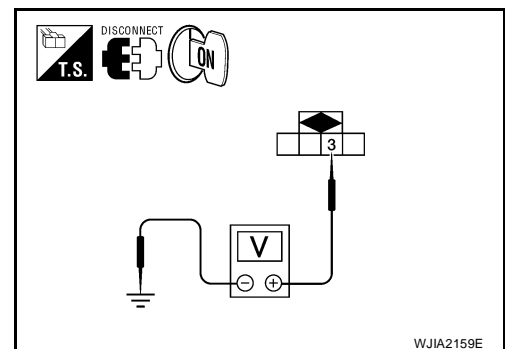

TROUBLE DIAGNOSIS

8. CHECK IN-VEHICLE SENSOR MOTOR GROUND CIRCUIT (SELF-DIAGNOSIS CODES 44 OR 46)

Check continuity between in-vehicle sensor harness connector M32 terminal 2 and ground.

Continuity should exist.

OK or NG

- OK >> Replace the in-vehicle sensor. Refer to [ATC-163, "IN-VEHICLE SENSOR"](#).
- NG >> Repair harness or connector.

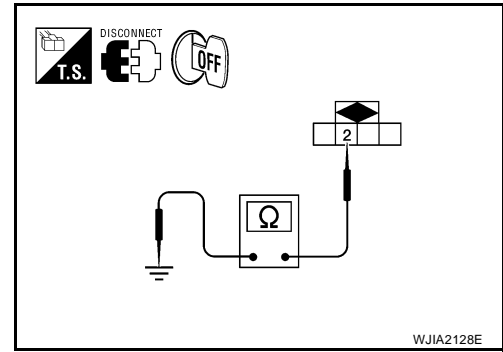

9. CHECK CIRCUIT CONTINUITY BETWEEN IN-VEHICLE SENSOR MOTOR AND FRONT AIR CONTROL (SELF-DIAGNOSIS CODES 44 OR 46)

1. Disconnect front air control connector.
2. Check continuity between in-vehicle sensor harness connector M32 (B) terminal 3 and front air control harness connector M50 (A) terminal 31.

Continuity should exist.

OK or NG

- OK >> Replace the front air control. Refer to [ATC-160, "FRONT AIR CONTROL"](#).
- NG >> Repair harness or connector.

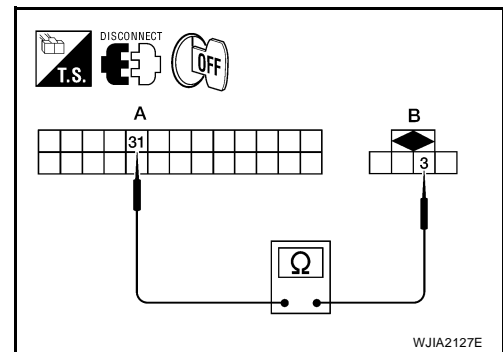

COMPONENT INSPECTION

In-vehicle Sensor

After disconnecting in-vehicle sensor (1) connector, measure resistance between terminals 1 and 4 at sensor component side, using the table below.

Temperature °C (°F)	Resistance kΩ
-15 (5)	21.40
-10 (14)	16.15
-5 (23)	12.29
0 (32)	9.41
5 (41)	7.27
10 (50)	5.66
15 (59)	4.45
20 (68)	3.51
25 (77)	2.79
30 (86)	2.24
35 (95)	1.80
40 (104)	1.45
45 (113)	1.18

If NG, replace in-vehicle sensor.

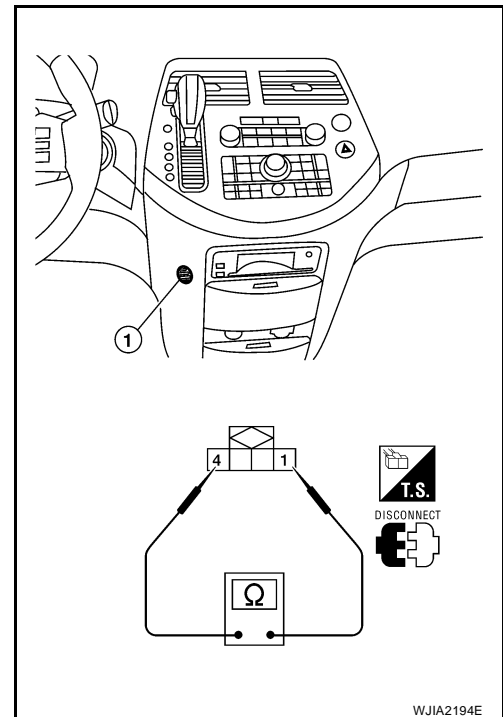

TROUBLE DIAGNOSIS

EJS004KH

Optical Sensor Circuit COMPONENT DESCRIPTION

The optical sensor M16 (1) is located on the passenger side defroster grille. It detects sunload entering through windshield by means of a photo diode. The sensor converts the sunload into a current value which is then input into the front air control

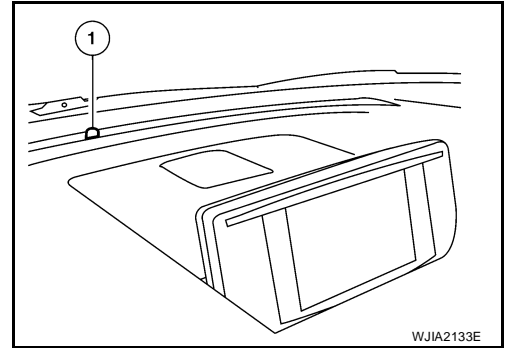

OPTICAL INPUT PROCESS

The front air control also includes a processing circuit which averages the variations in detected sunload over a period of time. This prevents adjustments in the ATC system operation due to small or quick variations in detected sunload.

For example, consider driving along a road bordered by an occasional group of large trees. The sunload detected by the optical sensor will vary whenever the trees obstruct the sunlight. The processing circuit averages the detected sunload over a period of time, so that the (insignificant) effect of the trees momentarily obstructing the sunlight does not cause any change in the ATC system operation. On the other hand, shortly after entering a long tunnel, the system will recognize the change in sunload, and the system will react accordingly.

DIAGNOSTIC PROCEDURE FOR OPTICAL SENSOR

SYMPTOM: Optical sensor circuit is open or shorted. Using the CONSULT-II, DTC B257F or B2580 is displayed. Without a CONSULT-II, code 50 or 52 is indicated on front air control as a result of conducting the front air control self-diagnosis.

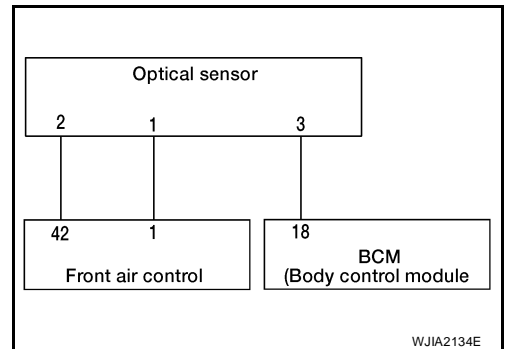

1. CHECK OPTICAL SENSOR (DRIVER) CIRCUIT VOLTAGE

1. Turn ignition switch OFF.
2. Disconnect optical sensor connector.
3. Turn ignition switch ON.
4. Check voltage between optical sensor harness connector M16 terminal 1 and ground.

Connector	Terminals		Voltage (Approx.)
	(+)	(-)	
Optical sensor: M16	1	Ground	5V

OK or NG

- OK >> GO TO 2.
NG >> GO TO 5.

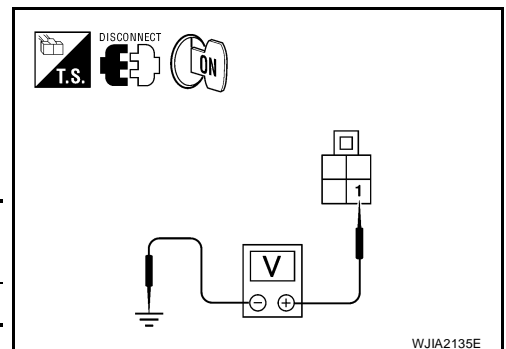

TROUBLE DIAGNOSIS

2. CHECK OPTICAL SENSOR (PASSENGER) CIRCUIT VOLTAGE

Check voltage between optical sensor harness connector M16 terminal 2 and ground.

Connector	Terminals		Voltage (Approx.)
	(+)	(-)	
Optical sensor: M16	2	Ground	5V

OK or NG

- OK >> GO TO 3.
- NG >> GO TO 6.

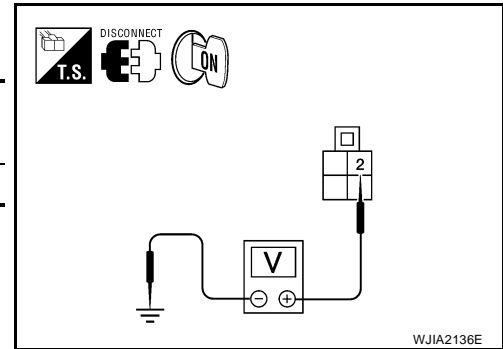

3. CHECK OPTICAL SENSOR GROUND CIRCUIT

- Turn ignition switch OFF.
- Check continuity between optical sensor harness connector M16 terminal 3 and ground.

Continuity should exist.

OK or NG

- OK >> Replace optical sensor. Refer to [ATC-164, "OPTICAL SENSOR"](#).
- NG >> GO TO 4.

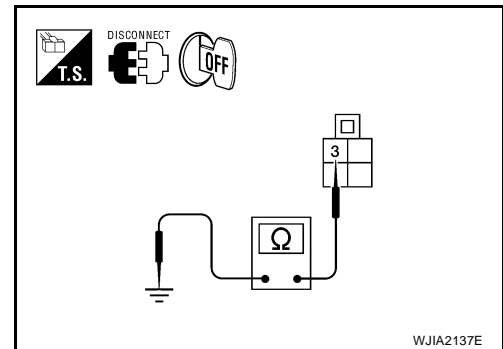

4. CHECK CIRCUIT CONTINUITY BETWEEN OPTICAL SENSOR AND BCM

- Disconnect BCM.
- Check continuity between optical sensor harness connector M16 (B) terminal 3 and BCM harness connector M18 (A) terminal 18.

Continuity should exist.

OK or NG

- OK >> Replace BCM. Refer to [BCS-25, "Removal and Installation of BCM"](#).
- NG >> Repair harness or connector.

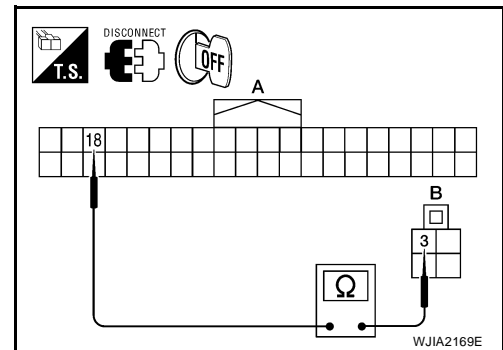

5. CHECK OPTICAL SENSOR (DRIVER) CIRCUIT FOR OPEN OR SHORTED

- Turn ignition switch OFF.
- Disconnect front air control connector.
- Check continuity between optical sensor harness connector M16 (B) terminal 1 and front air control harness connector M49 (A) terminal 1.

Continuity should exist.

- Check continuity between optical sensor harness connector M16 (B) terminal 1 and ground.

Continuity should not exist.

OK or NG

- OK >> Replace front air control. Refer to [ATC-160, "FRONT AIR CONTROL"](#).
- NG >> Repair harness or connector.

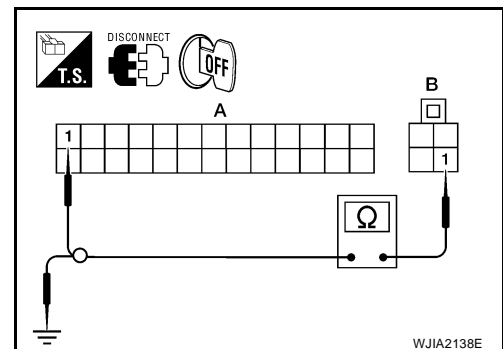

TROUBLE DIAGNOSIS

6. CHECK OPTICAL SENSOR (PASSENGER) CIRCUIT FOR OPEN AND SHORTED

1. Turn ignition switch OFF.
2. Disconnect front air control connector.
3. Check continuity between optical sensor harness connector M16 (B) terminal 2 and front air control harness connector M50 (A) terminal 42.

Continuity should exist.

4. Check continuity between optical sensor harness connector M16 (B) terminal 2 and ground.

Continuity should not exist.

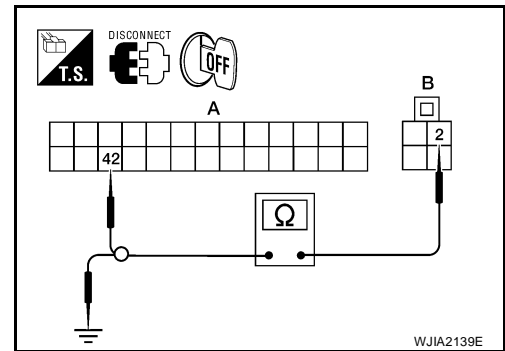

OK or NG

- OK >> Replace front air control. Refer to [ATC-160, "FRONT AIR CONTROL"](#).
- NG >> Repair harness or connector.

A
B
C
D
E
F
G
H
I
K
L
M

ATC

TROUBLE DIAGNOSIS

EJS004K1

Intake Sensor Circuit COMPONENT DESCRIPTION

Intake Sensor

The intake sensor is located on the heater & cooling unit assembly. It converts temperature of air after it passes through the evaporator into a resistance value which is then input to the front air control.

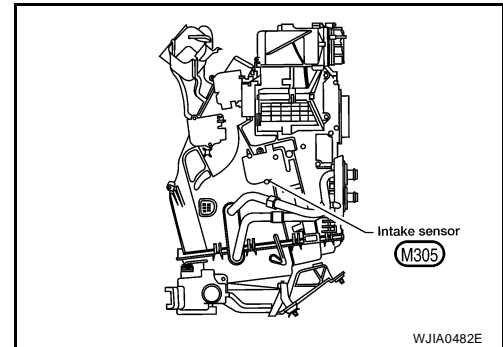

DIAGNOSTIC PROCEDURE FOR INTAKE SENSOR

SYMPTOM: Intake sensor circuit is open or shorted. Using the CONSULT-II, DTC B2581 or B2582 is displayed. Without a CONSULT-II, code 56 or 57 is indicated on front air control as a result of conducting the front air control self-diagnosis.

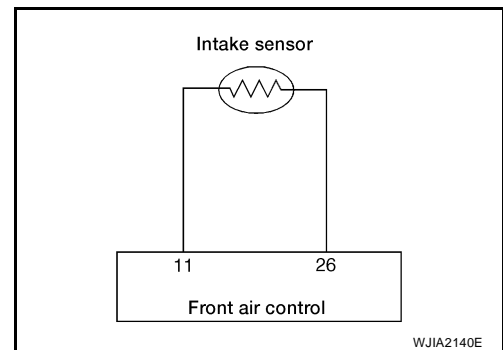

1. CHECK VOLTAGE BETWEEN INTAKE SENSOR AND GROUND

1. Disconnect intake sensor connector.
2. Turn ignition switch ON.
3. Check voltage between intake sensor harness connector M305 terminal 2 and ground.

Approx. 5V

OK or NG

- OK >> GO TO 2.
NG >> GO TO 4.

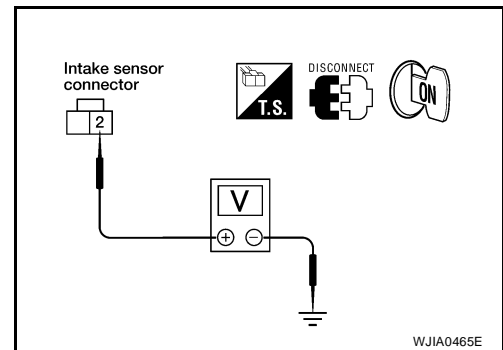

2. CHECK CIRCUIT CONTINUITY BETWEEN INTAKE SENSOR AND FRONT AIR CONTROL

1. Turn ignition switch OFF.
2. Disconnect front air control connector.
3. Check continuity between intake sensor harness connector M305 (B) terminal 1 and front air control harness connector M49 (A) terminal 26.

Continuity should exist.

OK or NG

- OK >> GO TO 3.
NG >> Repair harness or connector.

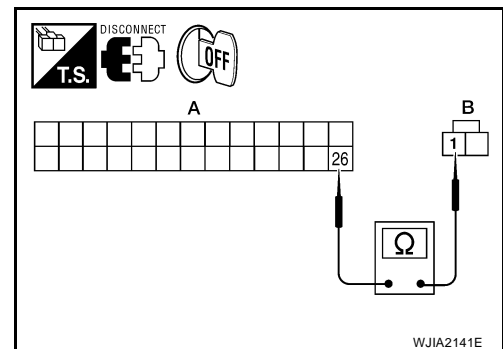

TROUBLE DIAGNOSIS

3. CHECK INTAKE SENSOR

Check intake sensor. Refer to [ATC-159, "Intake Sensor"](#) .

OK or NG

- OK >> 1. Replace front air control. Refer to [ATC-160, "FRONT AIR CONTROL"](#) .
 2. Go to [ATC-53, "A/C System Self-diagnosis Function"](#) and perform self-diagnosis.
- NG >> 1. Replace intake sensor. Refer to [ATC-165, "INTAKE SENSOR"](#) .
 2. Go to [ATC-53, "A/C System Self-diagnosis Function"](#) and perform self-diagnosis.

4. CHECK CIRCUIT CONTINUITY BETWEEN INTAKE SENSOR AND FRONT AIR CONTROL

- Turn ignition switch OFF.
- Disconnect front air control connector.
- Check continuity between intake sensor harness connector M305 (B) terminal 2 and front air control harness connector M49 (A) terminal 11.

Continuity should exist.

- Check continuity between intake sensor harness connector M305 (B) terminal 2 and ground.

Continuity should not exist.

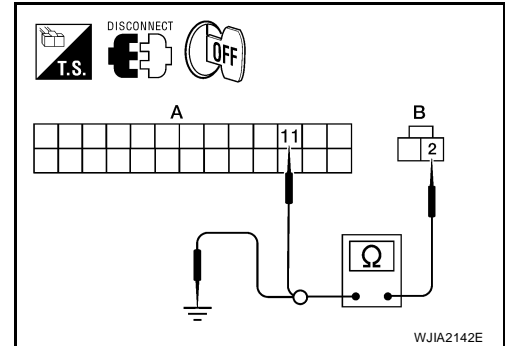

OK or NG

- OK >> 1. Replace front air control. Refer to [ATC-160, "FRONT AIR CONTROL"](#) .
 2. Go to [ATC-53, "A/C System Self-diagnosis Function"](#) and perform self-diagnosis.
- NG >> Repair harness or connector.

COMPONENT INSPECTION

Intake Sensor

After disconnecting intake sensor connector, measure resistance between terminals 1 and 2 at sensor harness side, using the table below.

Temperature °C (°F)	Resistance kΩ
-15 (5)	209.0
-10 (14)	160.0
-5 (23)	123.0
0 (32)	95.8
5 (41)	74.9
10 (50)	58.9
15 (59)	46.7
20 (68)	37.3
25 (77)	30.0
30 (86)	24.2
35 (95)	19.7
40 (104)	16.1
45 (113)	13.2

If NG, replace intake sensor.

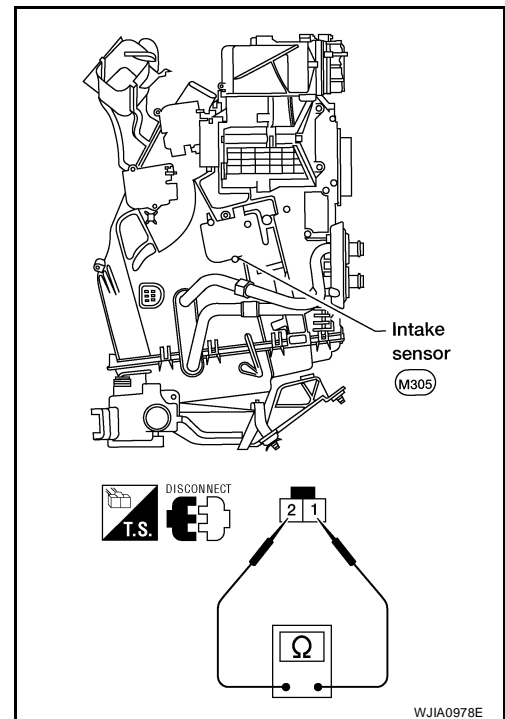

CONTROL UNIT

PFP:27500

EJS004KJ

CONTROL UNIT

Removal and Installation FRONT AIR CONTROL

Removal

1. Remove the control knobs from the front air control.
2. Remove cluster lid C, disconnect the front air control electrical connector. Refer to [IP-13, "Cluster Lid C"](#).
3. Remove the screws securing the front air control (1) to cluster lid C (2).

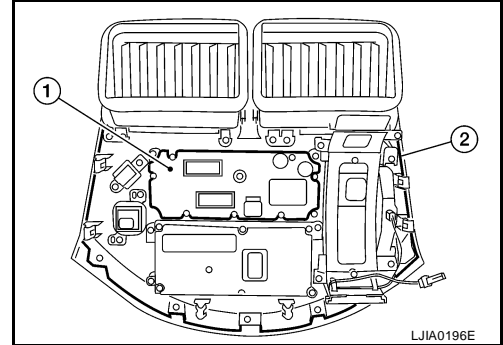

4. Remove the front air control.

Installation

Installation is the reverse order of removal.

REAR AIR CONTROL (FRONT)

Removal

1. Remove the control knobs from the rear air control (front).
2. Remove the front roof console assembly from the headlining, located over the rear view mirror. Refer to [EI-41, "HEADLINING"](#).
3. Remove the screws securing the rear air control (front) (1) to the front roof console assembly (2).

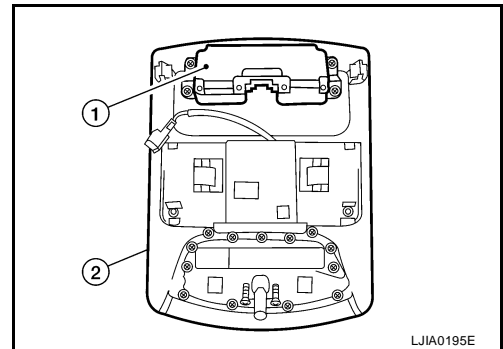

4. Remove the rear air control (front).

Installation

Installation is in the reverse order of removal.

REAR AIR CONTROL (REAR)

Removal

1. Remove the rear air control (rear) (1) from the headlining, located over the sliding door, RH.

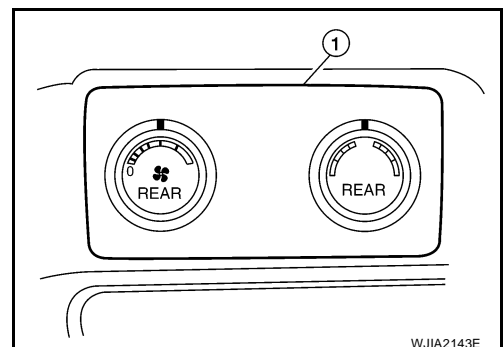

CONTROL UNIT

2. Disconnect the rear air control (rear) electrical connector and remove the rear air control (rear).

Installation

Installation is in the reverse order of removal.

A

B

C

D

E

F

G

H

I

ATC

K

L

M

AMBIENT SENSOR

AMBIENT SENSOR

PF2:27722

Removal and Installation

EJS004KK

REMOVAL

1. Disconnect the ambient sensor connector.

NOTE:

The ambient sensor is located behind the front bumper opening, in front of the condenser.

2. Release the ambient sensor clip and then remove the ambient sensor.

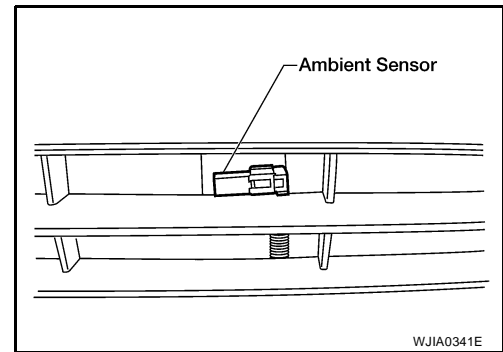

INSTALLATION

Installation is in the reverse order of removal.

IN-VEHICLE SENSOR

IN-VEHICLE SENSOR

PFP:27720

Removal and Installation

EJS004KL

REMOVAL

1. Remove the center stack. Refer to [IP-13, "Center Stack Trim Panel"](#) .
2. Remove the two screws and remove the in-vehicle sensor.

INSTALLATION

Installation is in the reverse order of removal.

A

B

C

D

E

F

G

H

I

ATC

K

L

M

OPTICAL SENSOR

OPTICAL SENSOR

PF2:28576

Removal and Installation

EJS004KM

The optical sensor is located in the top center of the defrost grille. Refer to [LT-50, "Removal and Installation"](#) .

INTAKE SENSOR

INTAKE SENSOR

PFP:27723

Removal and Installation

EJS004KN

Intake Sensor

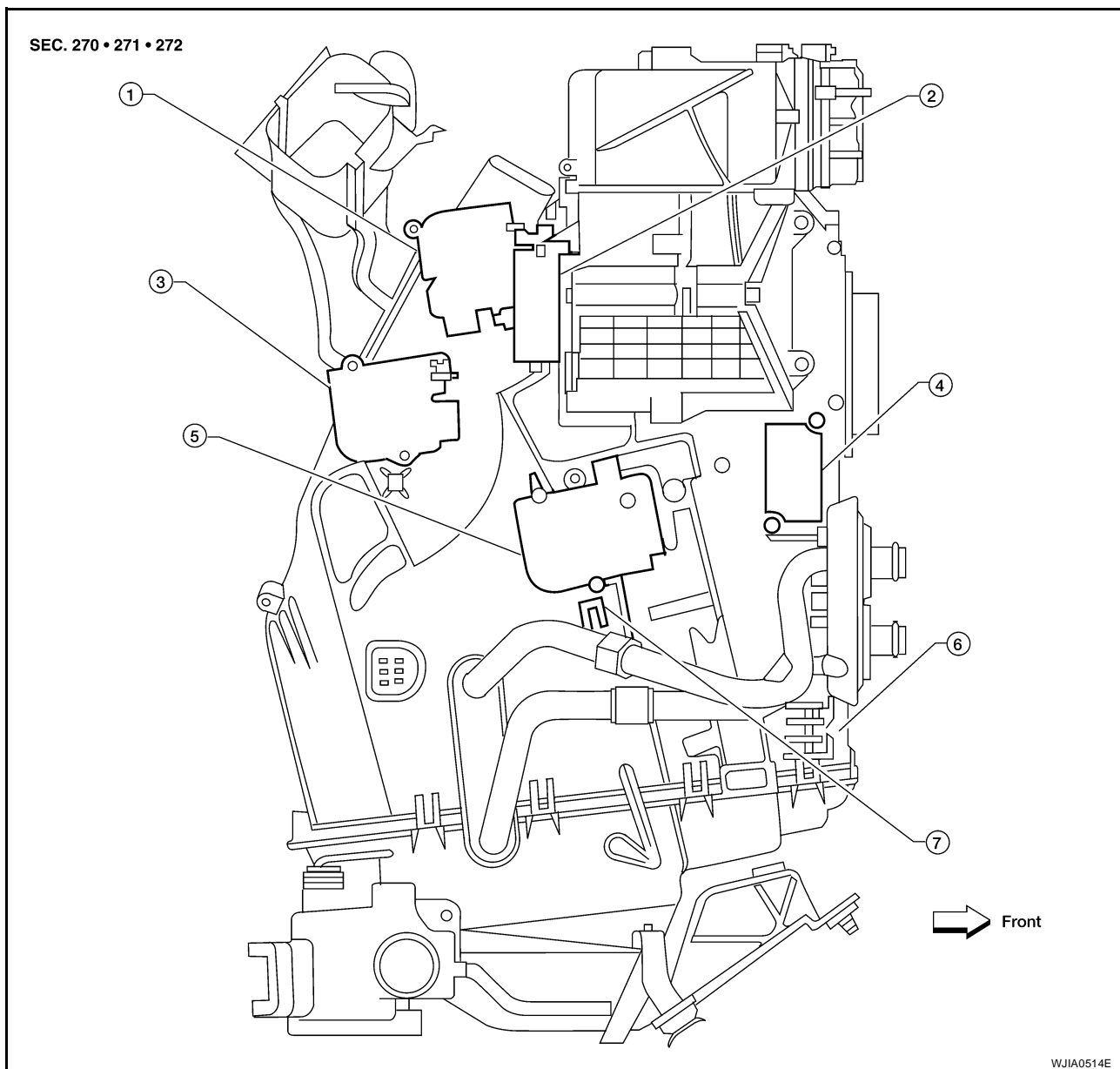

- | | | |
|------------------------------------|-----------------------------------|---|
| 1. Defroster door motor | 2. Intake door motor (passenger) | 3. Mode door motor |
| 4. Variable blower control (front) | 5. Air mix door motor (passenger) | 6. Front heater and cooling unit assembly |
| 7. Intake sensor | | |

REMOVAL

1. Remove the glove box assembly. Refer to [IP-14, "Glove Box"](#).
2. Disconnect the intake sensor electrical connector.
3. Twist the intake sensor to remove the intake sensor from the front heater and cooling unit assembly.

INSTALLATION

Installation is in the reverse order of removal.

A
B
C
D
E
F
G
H
I
ATC
K
L
M

BLOWER MOTOR

BLOWER MOTOR

PFP:27226

Components

EJS0053H

Front Blower Motor

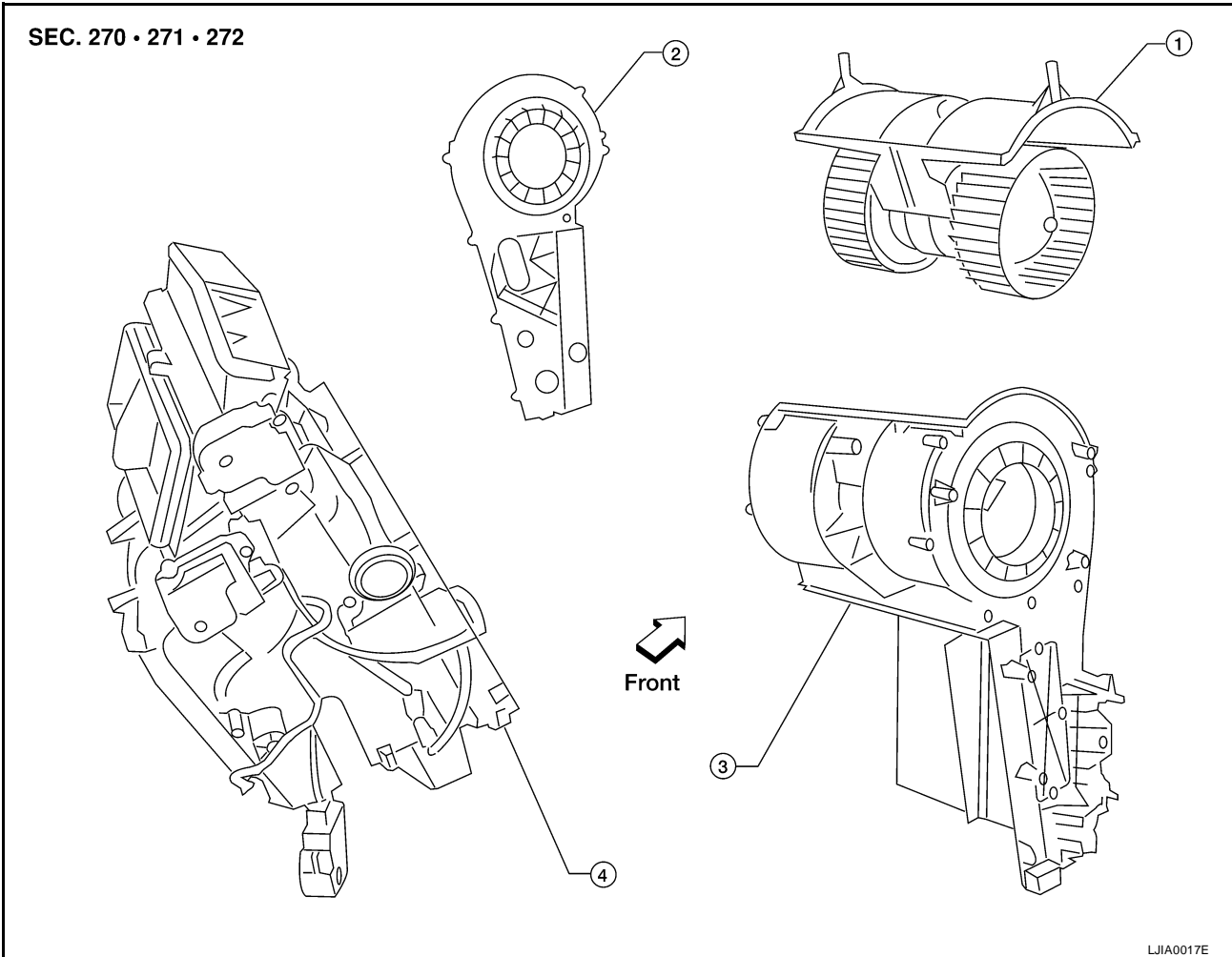

1. Front blower motor

2. Blower motor side cover

3. Blower motor case

4. Heater core and evaporator case

Rear Blower Motor

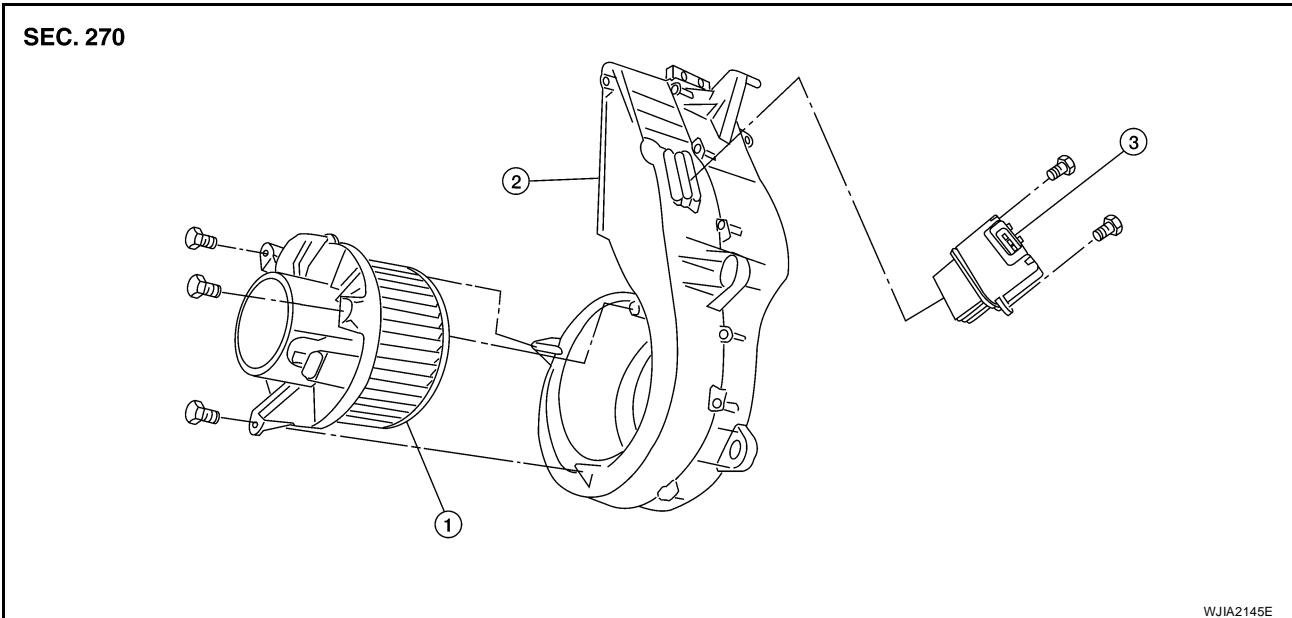

BLOWER MOTOR

1. Rear blower motor

2. Rear blower motor case

3. Variable blower control (rear)

Removal and Installation FRONT BLOWER MOTOR

EJS004KO

Removal

1. Remove the instrument panel. Refer to [IP-10, "Instrument Panel"](#) .
2. Remove the defroster duct. Refer to [ATC-190, "DEFROSTER DUCT"](#) .
3. Remove the front blower motor.

Installation

Installation is in the reverse order of removal.

REAR BLOWER MOTOR

Removal

1. Remove the rear heater and cooling unit assembly. Refer to [ATC-171, "REAR HEATER AND COOLING UNIT ASSEMBLY"](#) .
2. Remove the three screws and remove the blower motor.

Installation

Installation is in the reverse order of removal.

A

B

C

D

E

F

G

H

I

ATC

K

L

M

IN-CABIN MICROFILTER

IN-CABIN MICROFILTER

PF2:27277

Removal and Installation FUNCTION

EJS004KP

The air inside the passenger compartment is filtered by the in-cabin microfilters when the heater or A/C controls are set on either the recirculation or fresh mode. The two in-cabin microfilters are located in the front heater and cooling unit assembly. The rear heater and cooling unit assembly only draws in air from the passenger compartment to recirculate into the passenger compartment, so the rear heater and cooling unit assembly is not equipped with in-cabin microfilters.

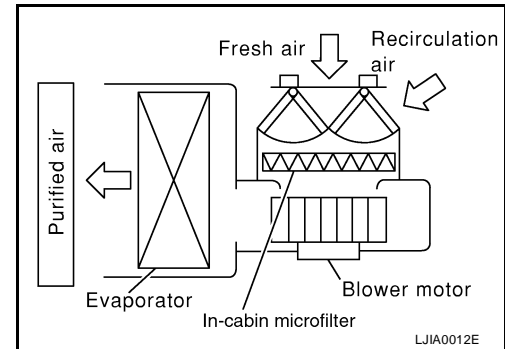

REPLACEMENT TIMING

Replacement of the two in-cabin microfilters is recommended on a regular interval depending on the driving conditions. Refer to [MA-6, "PERIODIC MAINTENANCE"](#). It may also be necessary to replace the two in-cabin microfilters as part of a component replacement if the in-cabin microfilters are damaged.

REPLACEMENT PROCEDURES

1. Remove the glove box assembly. Refer to [IP-14, "Glove Box"](#).
2. Remove the three screws and remove the in-cabin microfilter cover.
3. Remove the in-cabin microfilters from the front heater and cooling unit assembly.
4. Install the in-cabin microfilters, replacing the two in-cabin microfilters with new filters, into the front heater and cooling unit assembly.

CAUTION:

When installing the two new in-cabin microfilters make sure that the filters are facing in the direction indicated by the direction arrow for the air flow. The direction arrow is printed on the side of the in-cabin microfilters.

5. Install the in-cabin microfilter cover.
6. Install the glove box assembly. Refer to [IP-14, "Glove Box"](#).

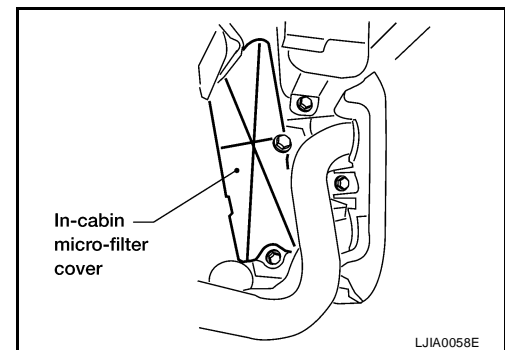

HEATER & COOLING UNIT ASSEMBLY

HEATER & COOLING UNIT ASSEMBLY

PF2:27110

Components

EJS004KQ

Front Heater and Cooling Unit Assembly

SEC. 270 • 276

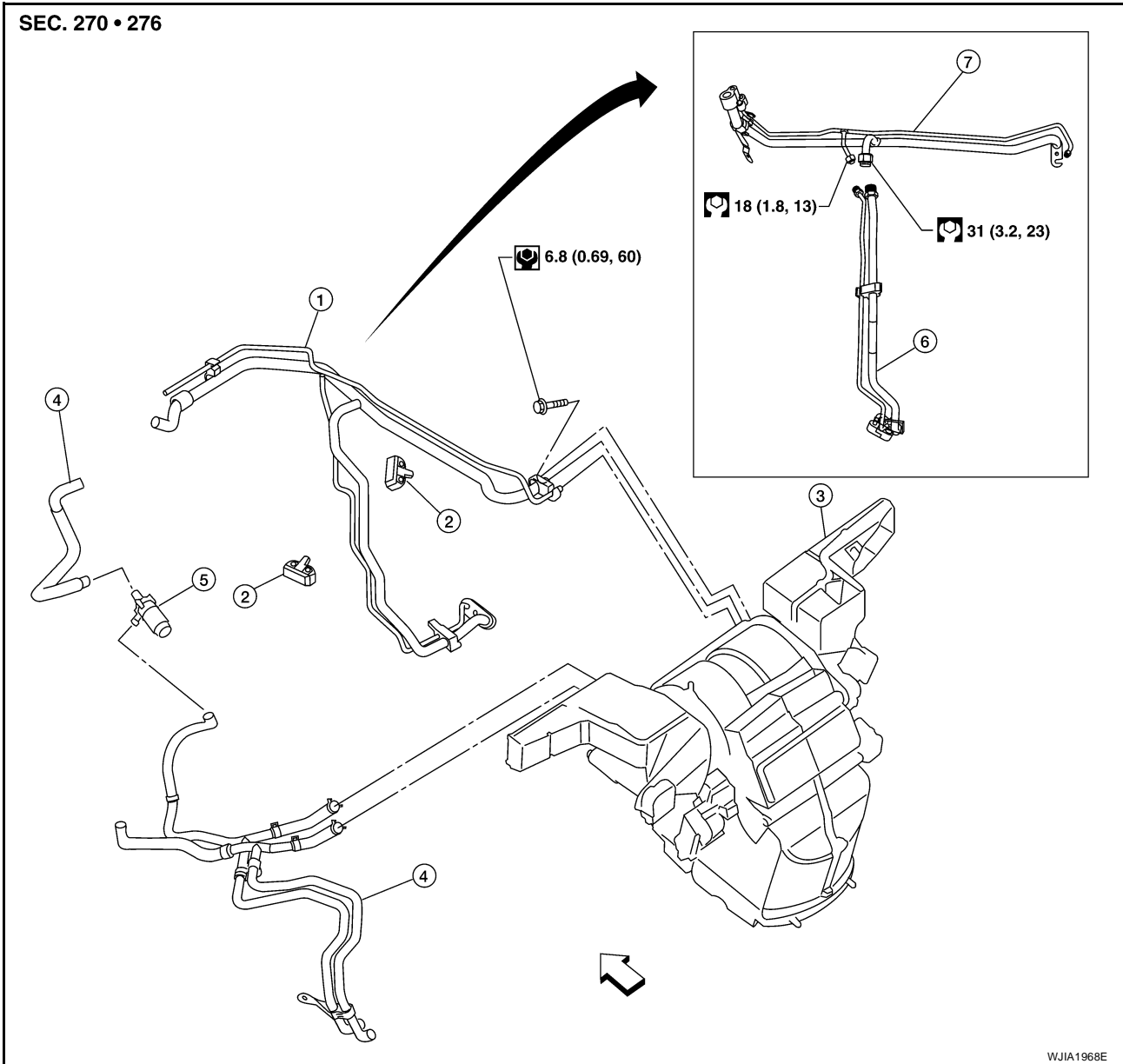

- | | | |
|---|-----------------------------------|---|
| 1. High/low pressure pipe (production) | 2. High/low pressure pipe bracket | 3. Front heater and cooling unit assembly |
| 4. Front heater core pipe and hose assembly | 5. Heater pump | 6. High/low pressure pipe - lower (service) |
| 7. High/low pressure pipe - upper (service) | ← Front | |

WJIA1968E

A
B
C
D
E
F
G
H
I
ATC
K
L
M

HEATER & COOLING UNIT ASSEMBLY

Rear Heater and Cooling Unit Assembly

SEC. 270 • 276

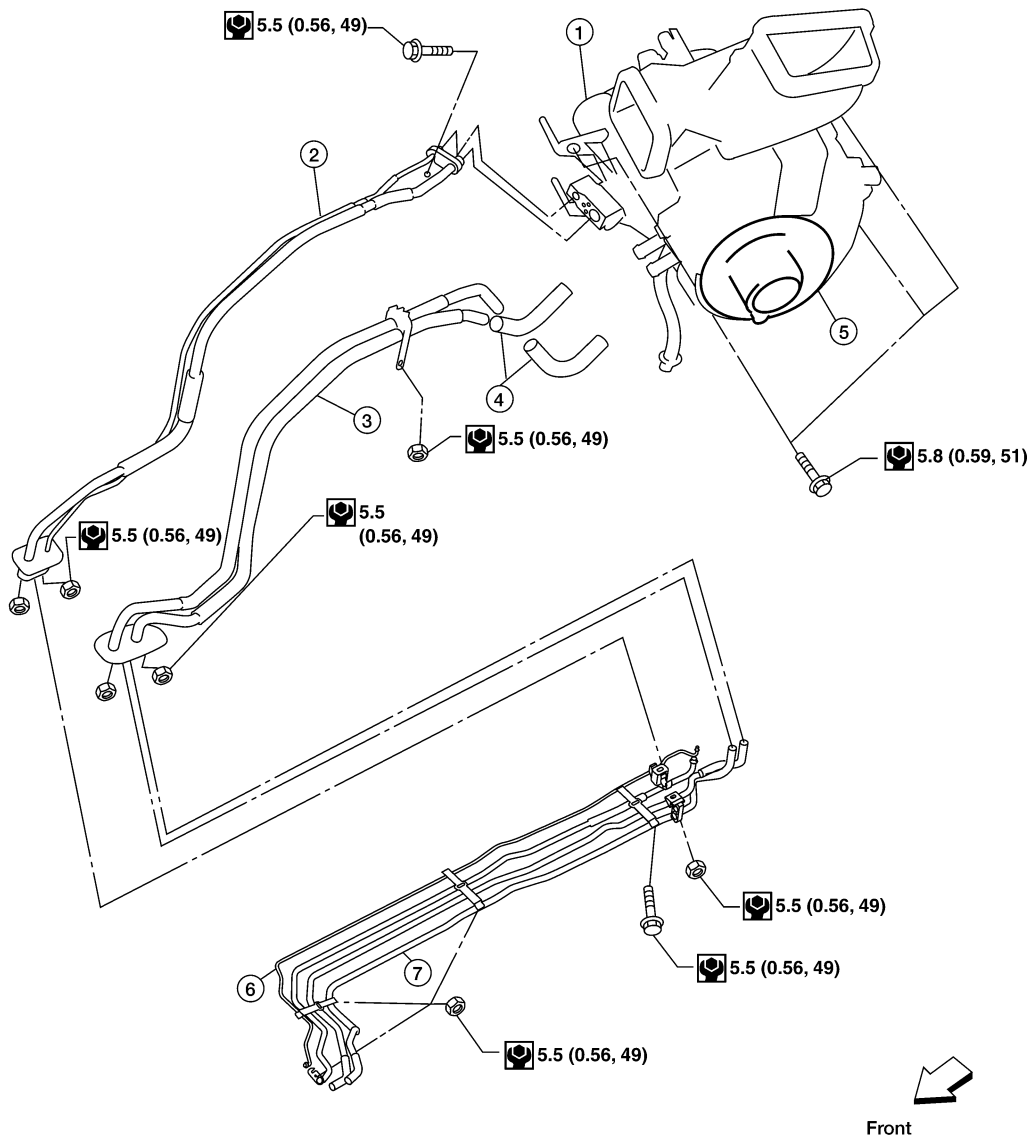

N·m (kg-m, in-lb)

- | | | |
|--|----------------------|------------------------------|
| 1. Rear heater and cooling unit assembly | 2. Rear A/C pipes | 3. Rear heater core pipes |
| 4. Rear heater core hose | 5. Rear blower motor | 6. Underfloor rear A/C pipes |
| 7. Underfloor rear heater core pipes | | |

LJIA0066E

EJS004KR

Removal and Installation FRONT HEATER AND COOLING UNIT ASSEMBLY

Removal

1. Discharge the refrigerant from the A/C system. Refer to [ATC-193, "Discharging Refrigerant"](#) .
2. Drain the coolant from the engine cooling system. Refer to [MA-13, "DRAINING ENGINE COOLANT"](#) .
3. Remove the cowl top extension. Refer to [EI-19, "Removal and Installation"](#) .
4. Disconnect the front heater hoses from the front heater core.
5. Disconnect the high/low pressure pipe from the front expansion valve.
6. Move the two front seats to the rearmost position on the seat track.

HEATER & COOLING UNIT ASSEMBLY

7. Remove the instrument panel. Refer to [IP-10, "Instrument Panel"](#) .
8. Disconnect the instrument panel wire harness at the RH and LH in-line connector brackets, and the fuse block (J/B) electrical connectors. Refer to [PG-44, "Harness Layout"](#) .
9. Disconnect the steering member from each side of the vehicle body.
10. Remove the front heater and cooling unit assembly with it attached to the steering member, from the vehicle.

CAUTION:

Use care not to damage the seats and interior trim panels when removing the front heater and cooling unit assembly with it attached to the steering member.

11. Remove the front heater and cooling unit assembly from the steering member.

Installation

Installation is in the reverse order of removal.

CAUTION:

- Replace the O-ring of the low-pressure flexible hose and high-pressure flexible hose with a new one, and apply compressor oil to it when installing it.
- After charging the refrigerant, check for leaks.

NOTE:

- Fill the engine cooling system with the specified coolant mixture. Refer to [MA-14, "REFILLING ENGINE COOLANT"](#) .
- Recharge the A/C system. Refer to [ATC-193, "Evacuating System and Charging Refrigerant"](#) .

REAR HEATER AND COOLING UNIT ASSEMBLY

Removal

1. Discharge the refrigerant from the A/C system. Refer to [ATC-193, "Discharging Refrigerant"](#) .
2. Drain the coolant from the engine cooling system. Refer to [MA-13, "DRAINING ENGINE COOLANT"](#) .
3. Remove the rear RH interior trim panel. Refer to [EI-33, "Removal and Installation"](#) .
4. Disconnect the rear heater core hoses from the rear heater core.
5. Disconnect the rear A/C pipes from the rear expansion valve.
6. Disconnect the following electrical connectors:
 - Rear blower motor
 - Rear blower motor resistor
 - Rear air mix door motor
7. Disconnect the ducts from the rear heater and cooling unit assembly.
8. Remove the rear heater and cooling unit assembly.

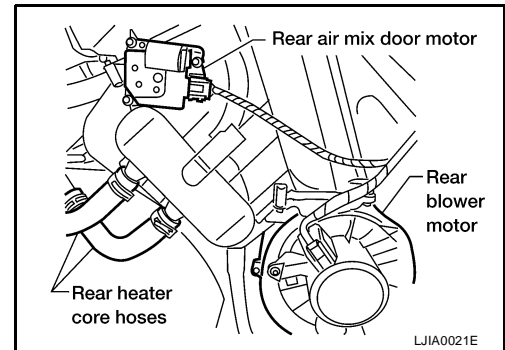

Installation

Installation is in the reverse order of removal.

CAUTION:

- Replace the O-ring of the low-pressure flexible hose and high-pressure flexible hose with a new one, and apply compressor oil to it when installing it.
- After charging the refrigerant, check for leaks.

NOTE:

- Fill the engine cooling system with the specified coolant mixture. Refer to [MA-14, "REFILLING ENGINE COOLANT"](#) .
- Recharge the A/C system. Refer to [ATC-193, "Evacuating System and Charging Refrigerant"](#) .

HEATER CORE

HEATER CORE

PF27140

Components

EJS004KS

Front Heater and Cooling Unit Assembly

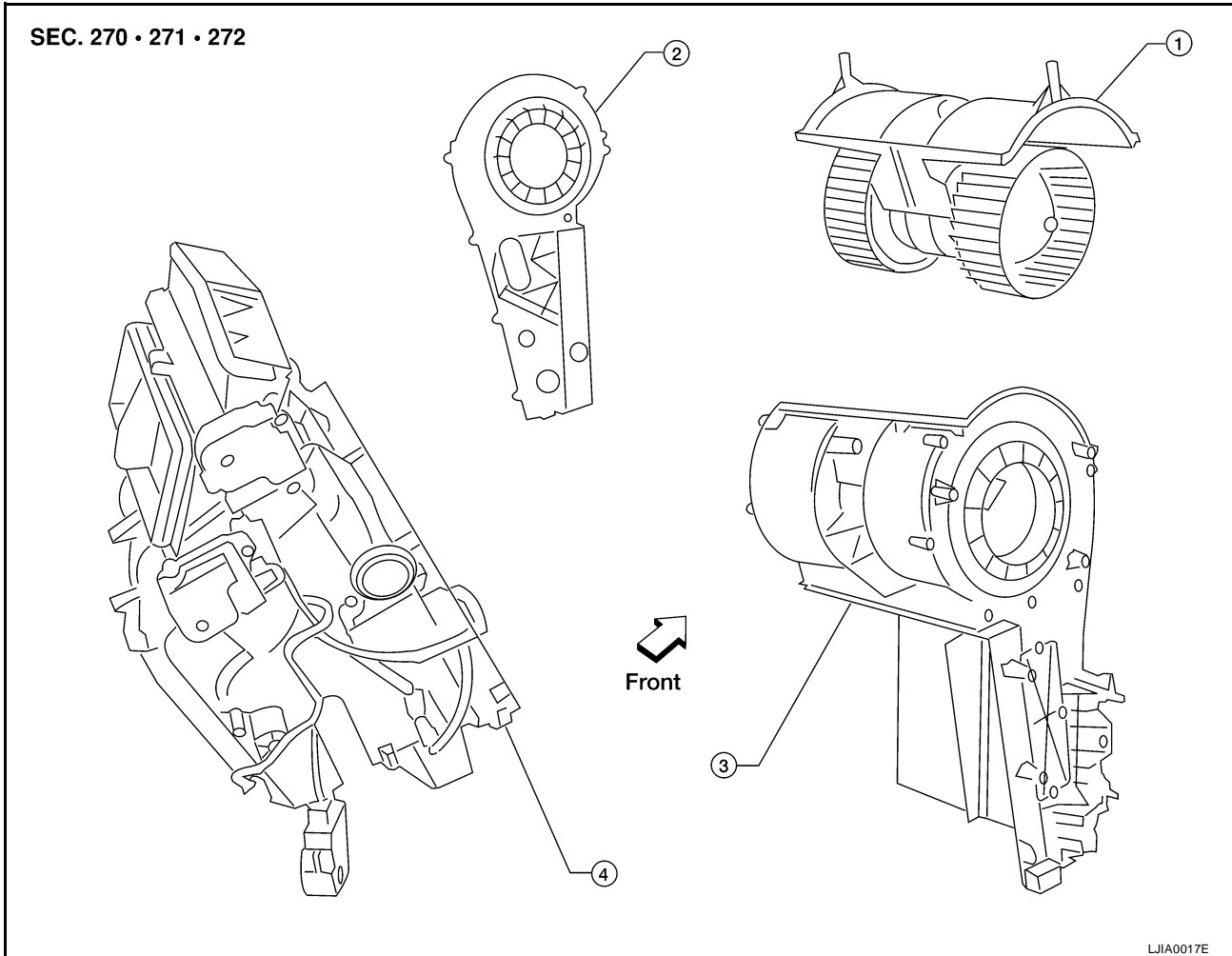

1. Front blower motor

2. Blower motor side cover

3. Blower motor case

4. Heater core and evaporator case

HEATER CORE

Rear Heater and Cooling Unit Assembly

SEC. 274

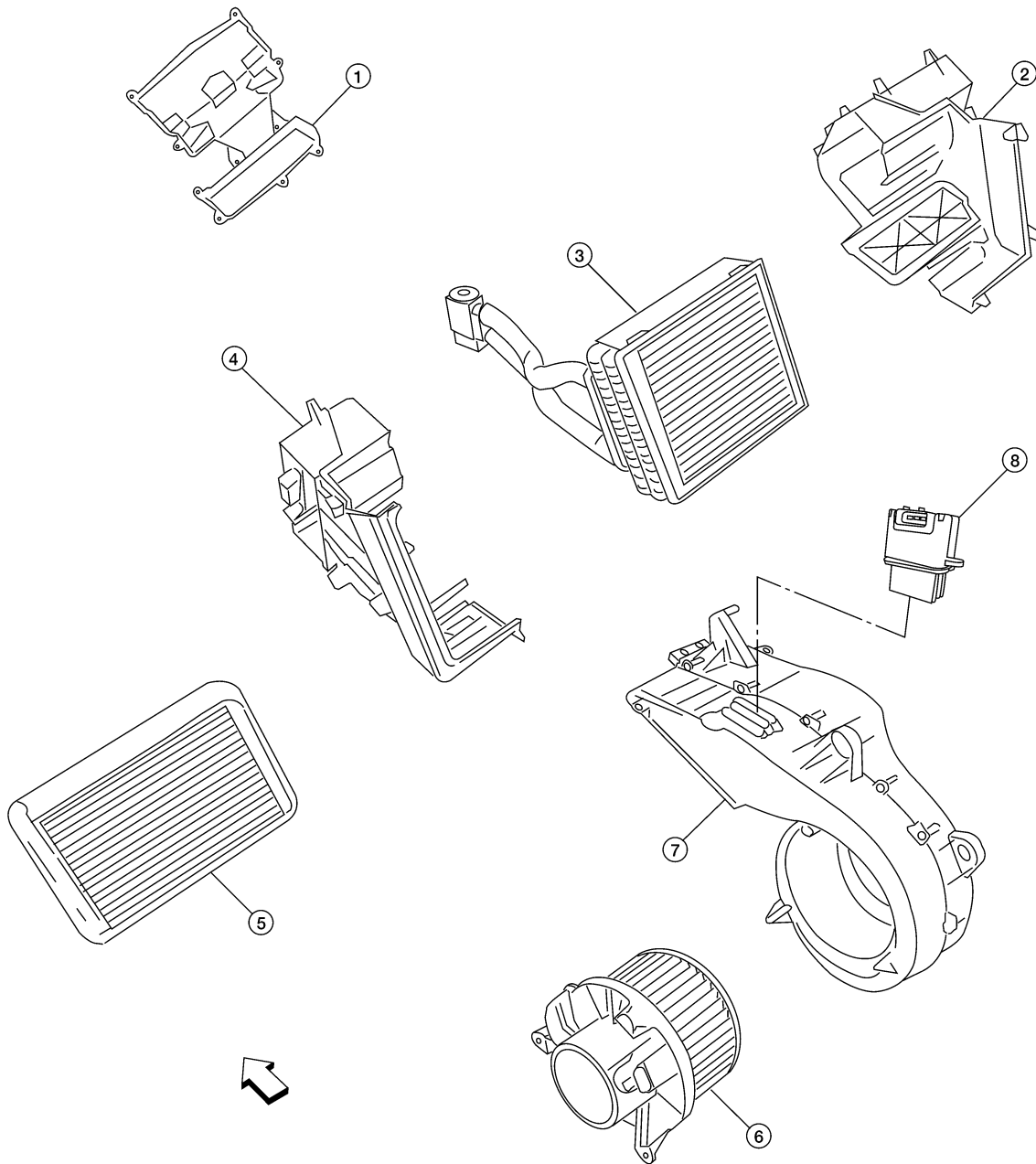

- | | | |
|----------------------|------------------------------------|----------------------|
| 1. Front cover | 2. Evaporator and heater core case | 3. Evaporator |
| 4. Side cover | 5. Heater core | 6. Rear blower motor |
| 7. Blower motor case | 8. Variable blower control (rear) | ← Front |

WJIA2146E

Removal and Installation FRONT HEATER CORE

EJS004KT

Removal

1. Remove the front heater and cooling unit assembly. Refer to [ATC-170, "FRONT HEATER AND COOLING UNIT ASSEMBLY"](#).

HEATER CORE

2. Remove the front heater core.

NOTE:

If the in-cabin microfilters are contaminated from coolant leaking from the heater core, replace the in-cabin microfilters with new ones before installing the new front heater core.

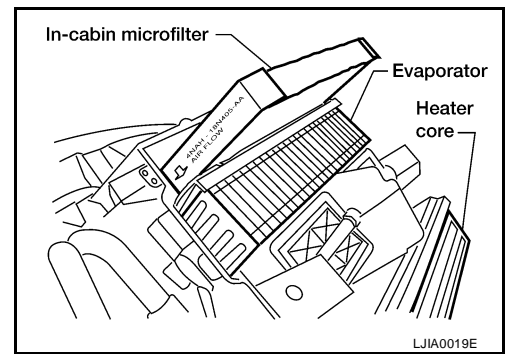

Installation

Installation is in the reverse order of removal.

REAR HEATER CORE

Removal

1. Partially drain the engine cooling system. Refer to [MA-13, "DRAINING ENGINE COOLANT"](#).
2. Remove the rear lower finisher assembly. Refer to [EI-33, "Removal and Installation"](#).
3. Disconnect the rear heater core hoses from the rear heater core.

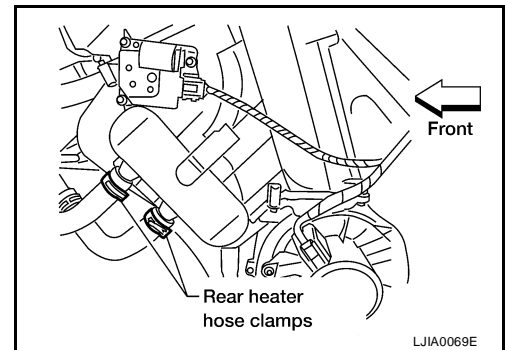

4. Remove the rear heater core bracket.
5. Remove the rear heater core.

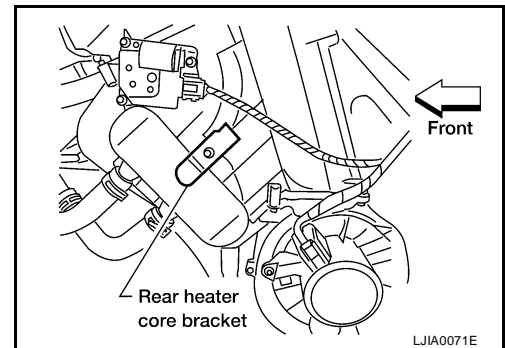

Installation

Installation is in the reverse order of removal.

HEATER PUMP

HEATER PUMP

PFP:92264

Removal and Installation

EJS004KU

Heater Pump

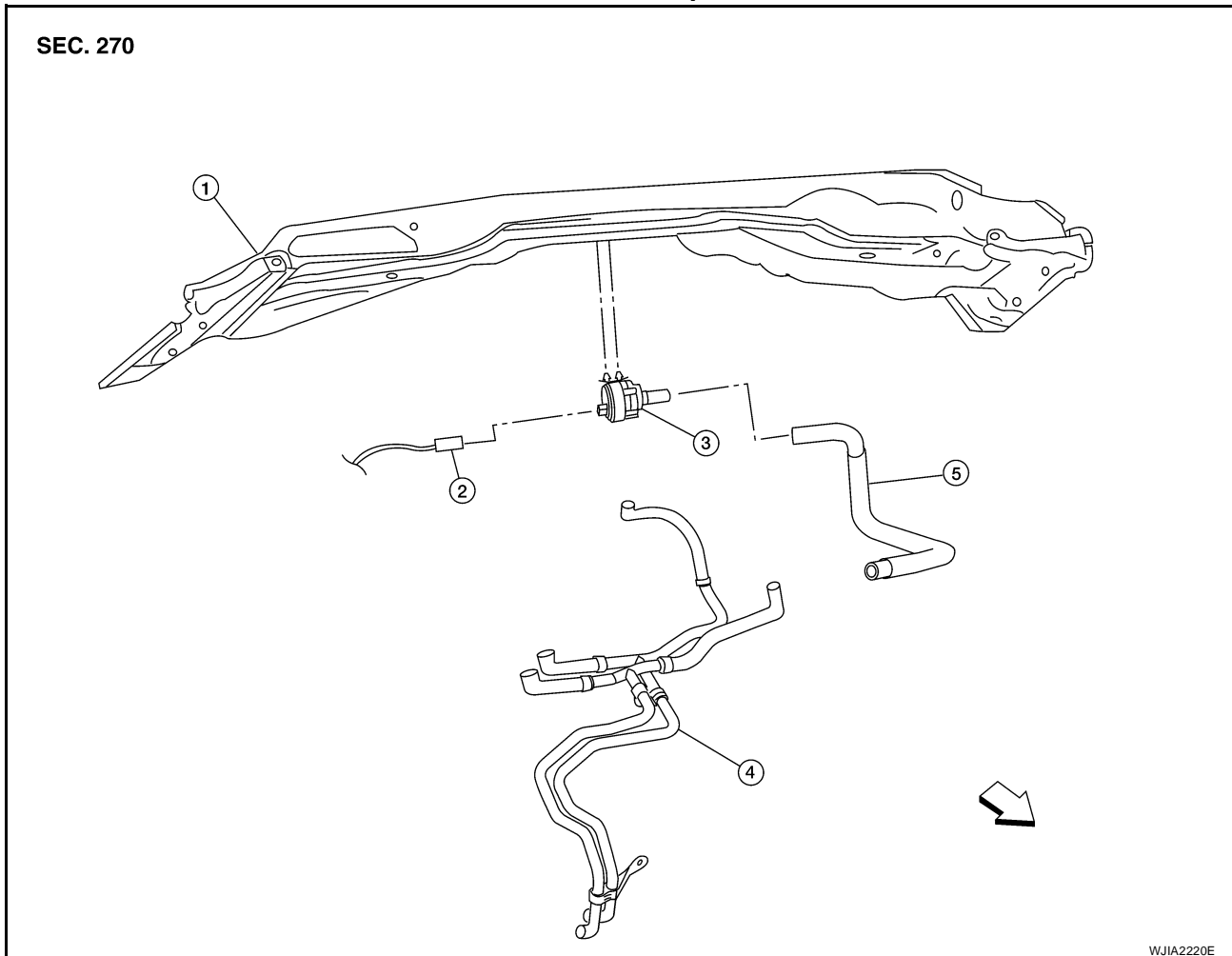

- | | | |
|---|-------------------------------------|----------------|
| 1. Cowl top extension | 2. Heater pump electrical connector | 3. Heater pump |
| 4. Front heater core pipe and hose assembly | 5. Heater hose | ← Front |

REMOVAL

1. Remove the cowl top. Refer to [EI-19, "COWL TOP"](#) .
2. Partially drain the engine cooling system. Refer to [MA-13, "DRAINING ENGINE COOLANT"](#) .
3. Unclip the heater pump from the cowl top extension.
4. Disconnect the heater pump electrical connector and the two heater hoses, then remove the heater pump.

CAUTION:

Do not disassemble the heater pump, replace the heater pump as an assembly.

INSTALLATION

Installation is in the reverse order of removal.

A
B
C
D
E
F
G
H
I
K
L
M

ATC

DEFROSTER DOOR MOTOR

DEFROSTER DOOR MOTOR

PFP:27733

Removal and Installation

EJS004KV

Defroster Door Motor - Front Heater and Cooling Unit Assembly

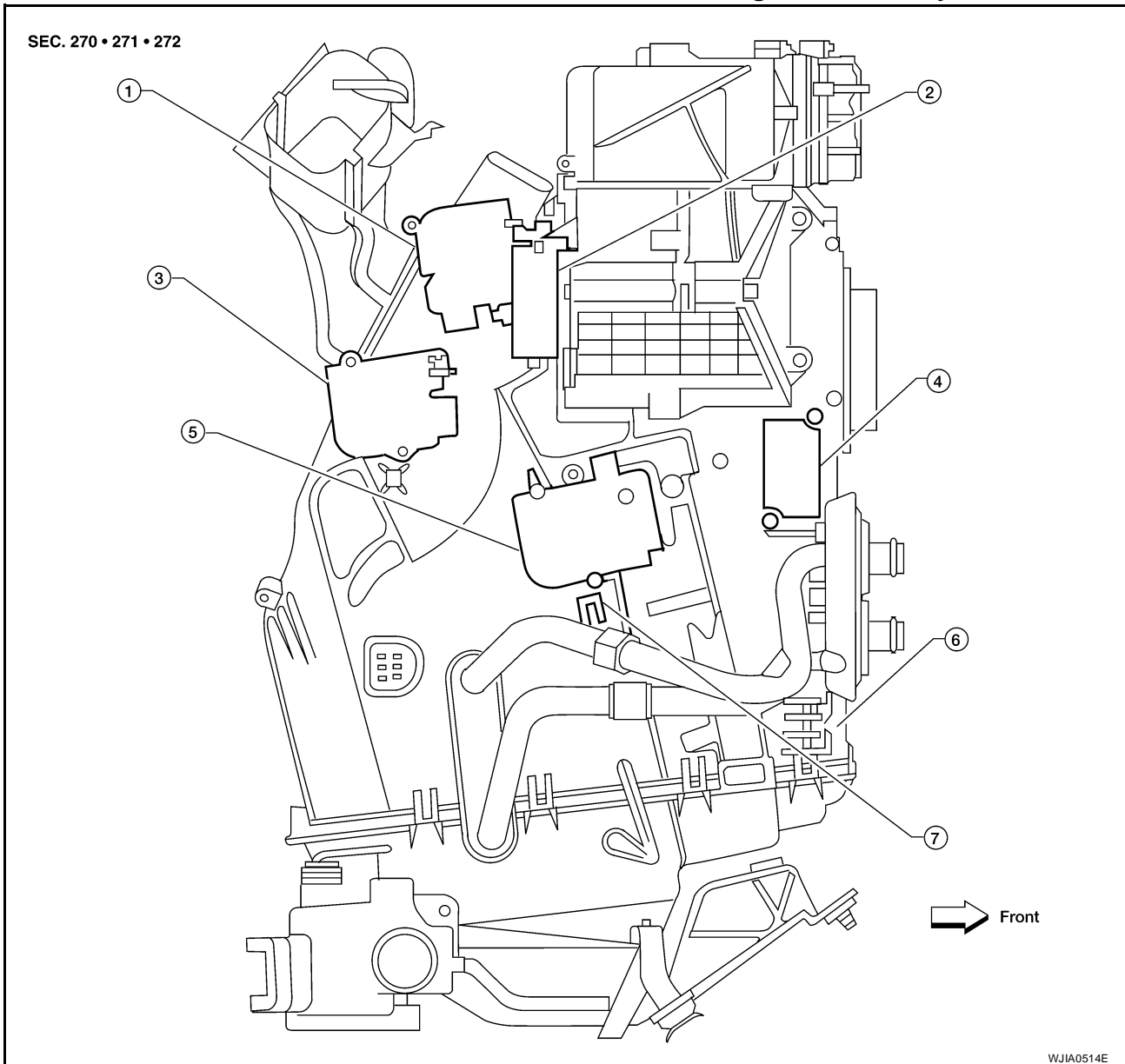

- | | | |
|------------------------------------|-----------------------------------|---|
| 1. Defroster door motor | 2. Intake door motor (passenger) | 3. Mode door motor |
| 4. Variable blower control (front) | 5. Air mix door motor (passenger) | 6. Front heater and cooling unit assembly |
| 7. Intake sensor | | |

REMOVAL

1. Remove the front heater and cooling unit assembly. Refer to [ATC-170, "FRONT HEATER AND COOLING UNIT ASSEMBLY"](#).
2. Remove the steering member from the front heater and cooling unit assembly.
3. Disconnect the defroster door motor electrical connector.
4. Remove the two screws and remove the defroster door motor.

INSTALLATION

Installation is in the reverse order of removal.

INTAKE DOOR MOTOR

PFP:27730

INTAKE DOOR MOTOR

Components

EJS004KW

Intake Door Motor (Driver) - Front Heater and Cooling Unit Assembly

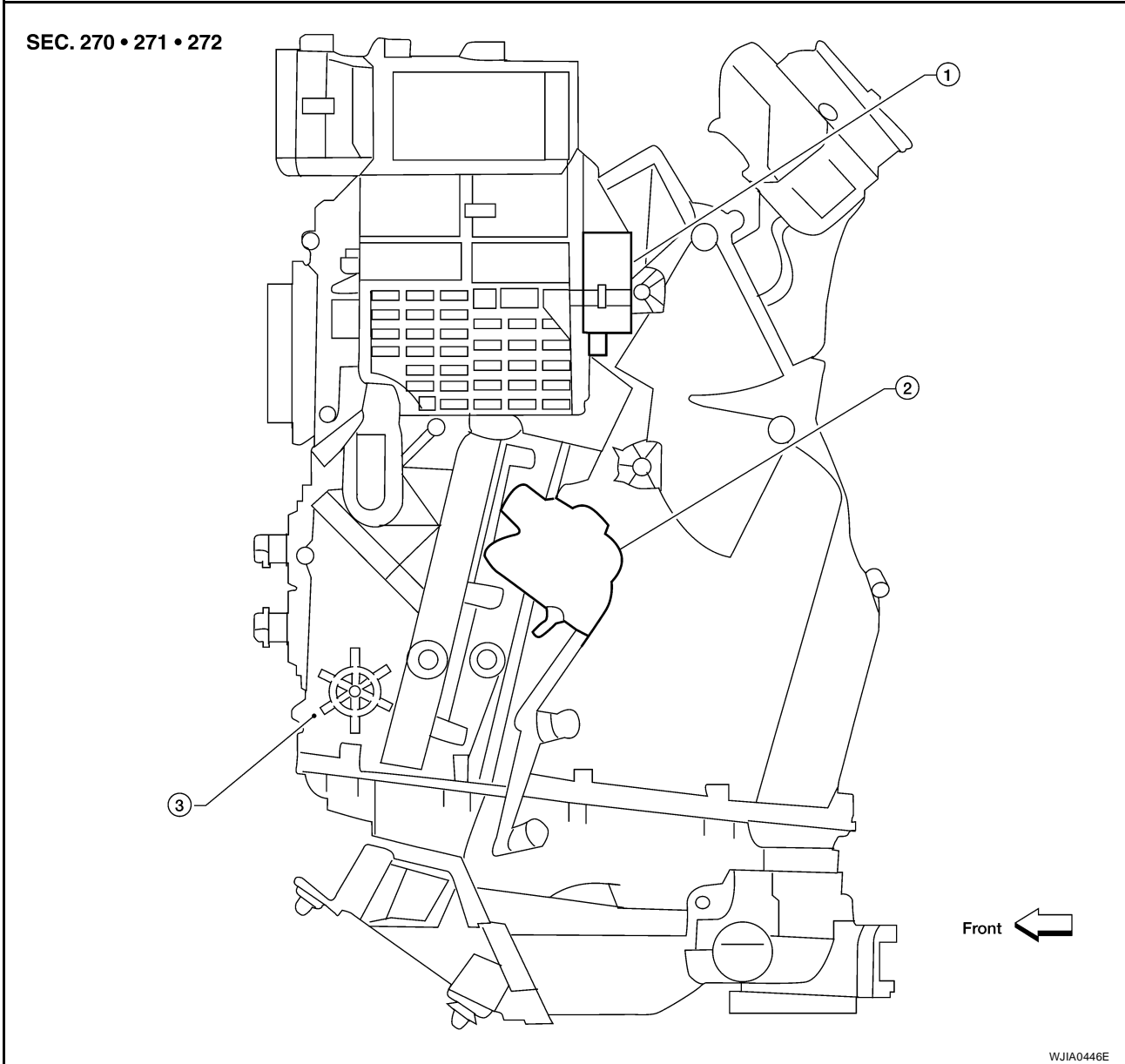

1. Intake door motor (driver)

2. Air mix door motor (driver)

3. Front heater and cooling unit assembly

A
B
C
D
E
F
G
H
I
ATC
K
L
M

INTAKE DOOR MOTOR

Intake Door Motor (Passenger) - Front Heater and Cooling Unit Assembly

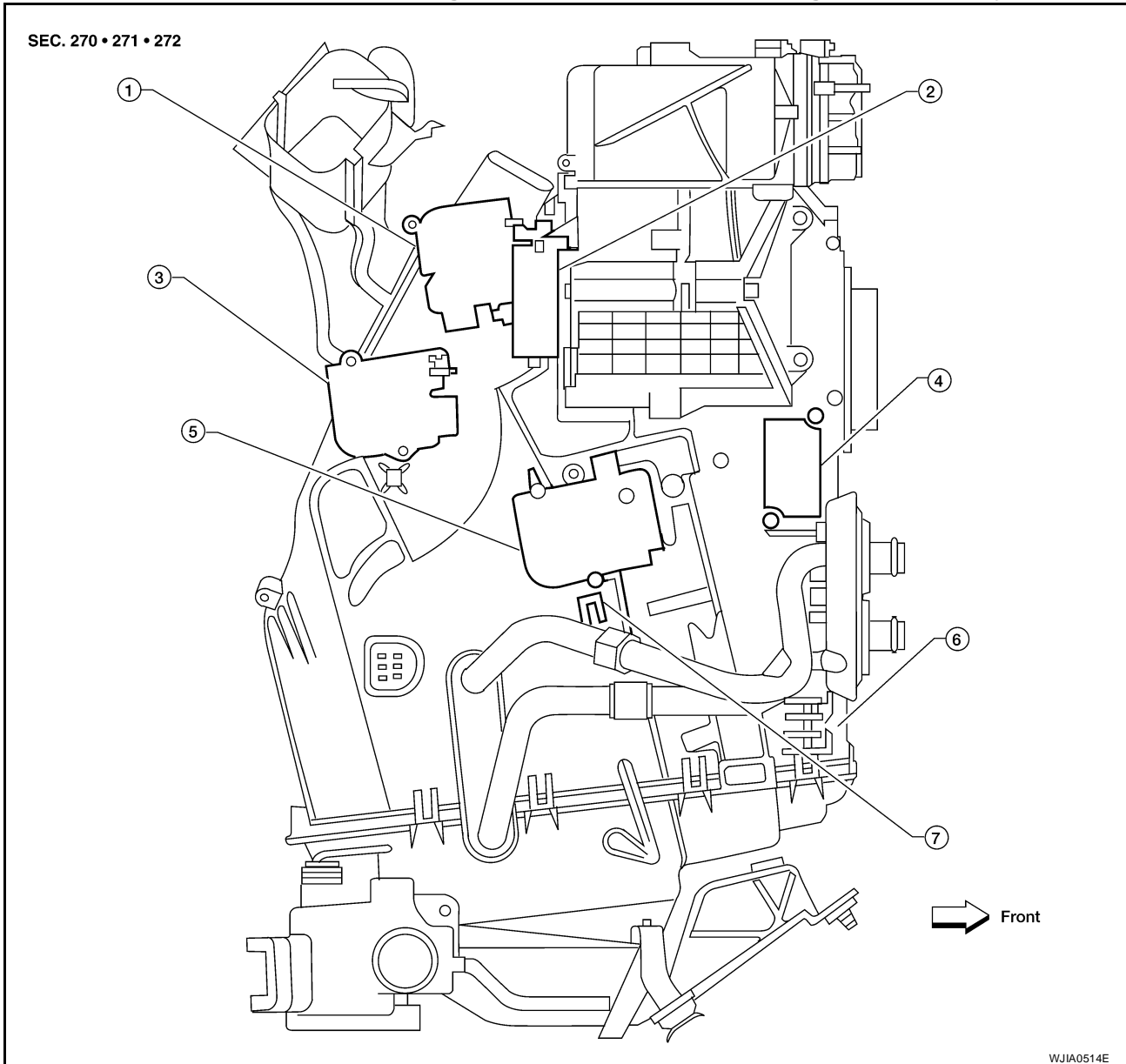

- | | | |
|------------------------------------|-----------------------------------|---|
| 1. Defroster door motor | 2. Intake door motor (passenger) | 3. Mode door motor |
| 4. Variable blower control (front) | 5. Air mix door motor (passenger) | 6. Front heater and cooling unit assembly |
| 7. Intake sensor | | |

Removal and Installation DRIVER SIDE

EJS004KX

Removal

1. Remove the instrument lower panel LH. Refer to [IP-12, "Instrument Lower Panel LH"](#) .
2. Remove the center stack. Refer to [IP-13, "Center Stack Trim Panel"](#) .

INTAKE DOOR MOTOR

3. Disconnect the intake door motor electrical connector.
4. Remove the three screws and remove the intake door motor.

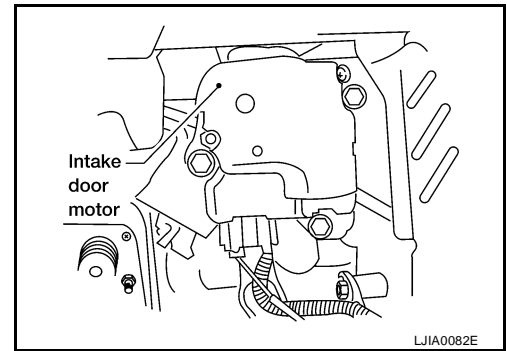

Installation

Installation is in the reverse order of removal.

PASSENGER SIDE

Removal

1. Remove the front heater and cooling unit assembly. Refer to [ATC-170, "FRONT HEATER AND COOLING UNIT ASSEMBLY"](#).
2. Remove the steering member from the front heater and cooling unit assembly.
3. Disconnect the intake door motor electrical connector.
4. Remove the three screws and remove the intake door motor.

Installation

Installation is in the reverse order of removal.

A

B

C

D

E

F

G

H

I

ATC

K

L

M

MODE DOOR MOTOR

MODE DOOR MOTOR

PF2:27731

Removal and Installation

EJS004KY

Mode Door Motor - Front Heater and Cooling Unit Assembly

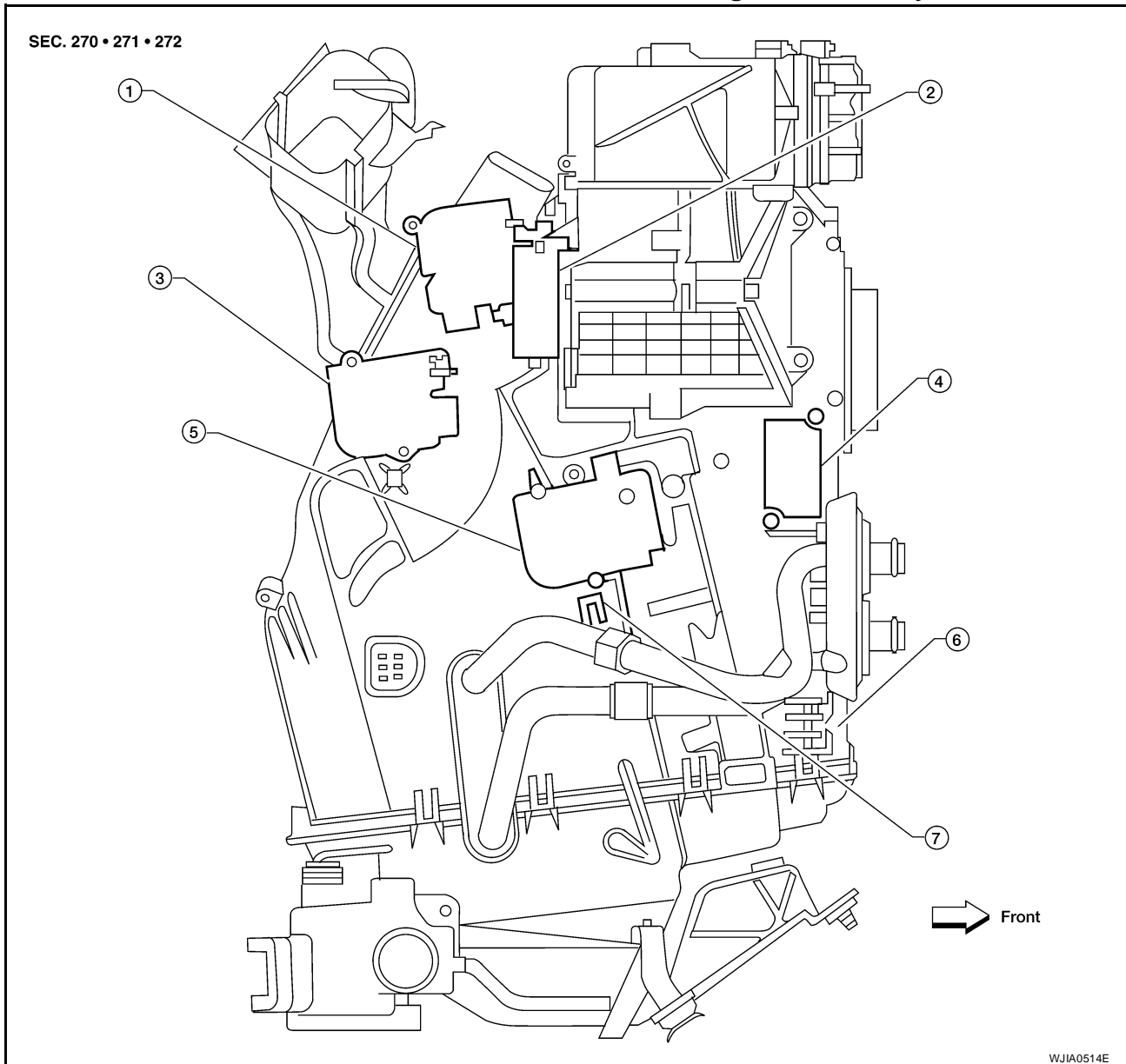

- | | | |
|------------------------------------|-----------------------------------|---|
| 1. Defroster door motor | 2. Intake door motor (passenger) | 3. Mode door motor |
| 4. Variable blower control (front) | 5. Air mix door motor (passenger) | 6. Front heater and cooling unit assembly |
| 7. Intake sensor | | |

REMOVAL

1. Remove the instrument lower panel RH and glove box. Refer to [IP-14, "Glove Box"](#).
2. Remove the center stack. Refer to [IP-13, "Center Stack Trim Panel"](#).

MODE DOOR MOTOR

3. Disconnect the mode door motor electrical connector.
4. Remove the three screws and remove the mode door motor.

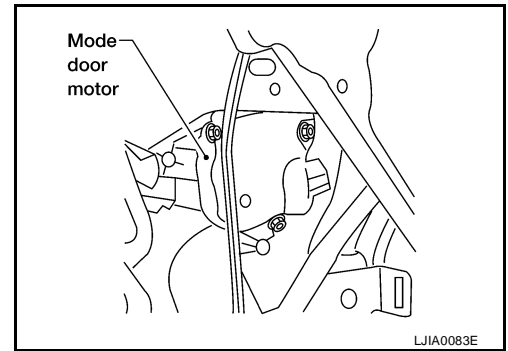

INSTALLATION

Installation is in the reverse order of removal.

A

B

C

D

E

F

G

H

I

ATC

K

L

M

AIR MIX DOOR MOTOR

AIR MIX DOOR MOTOR

PF2:27732

Components

EJS004KZ

Air Mix Door Motor (Driver) - Front Heater and Cooling Unit Assembly

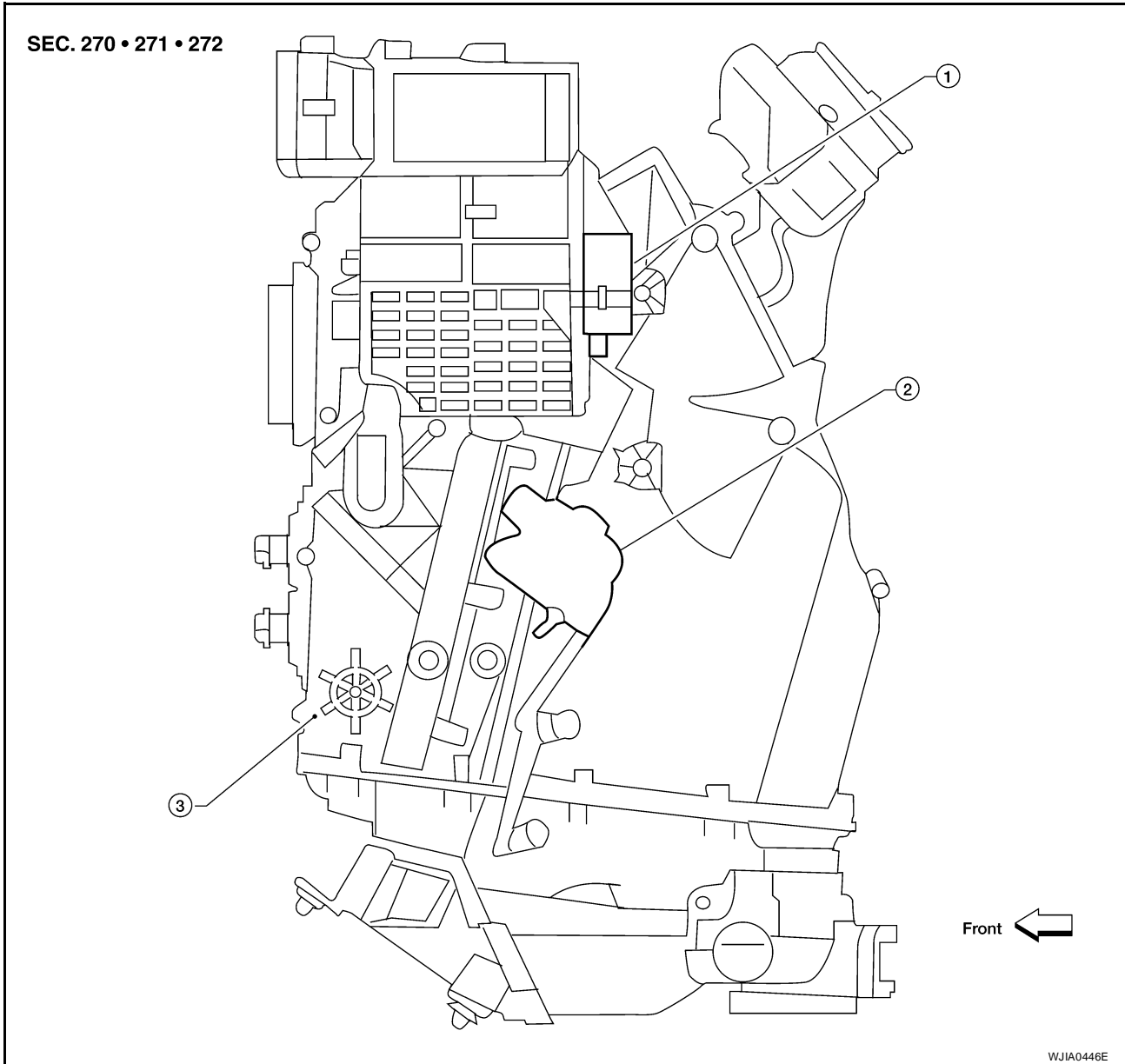

1. Intake door motor (driver)
2. Air mix door motor (driver)
3. Front heater and cooling unit assembly

AIR MIX DOOR MOTOR

Air Mix Door Motor (Passenger) - Front Heater and Cooling Unit Assembly

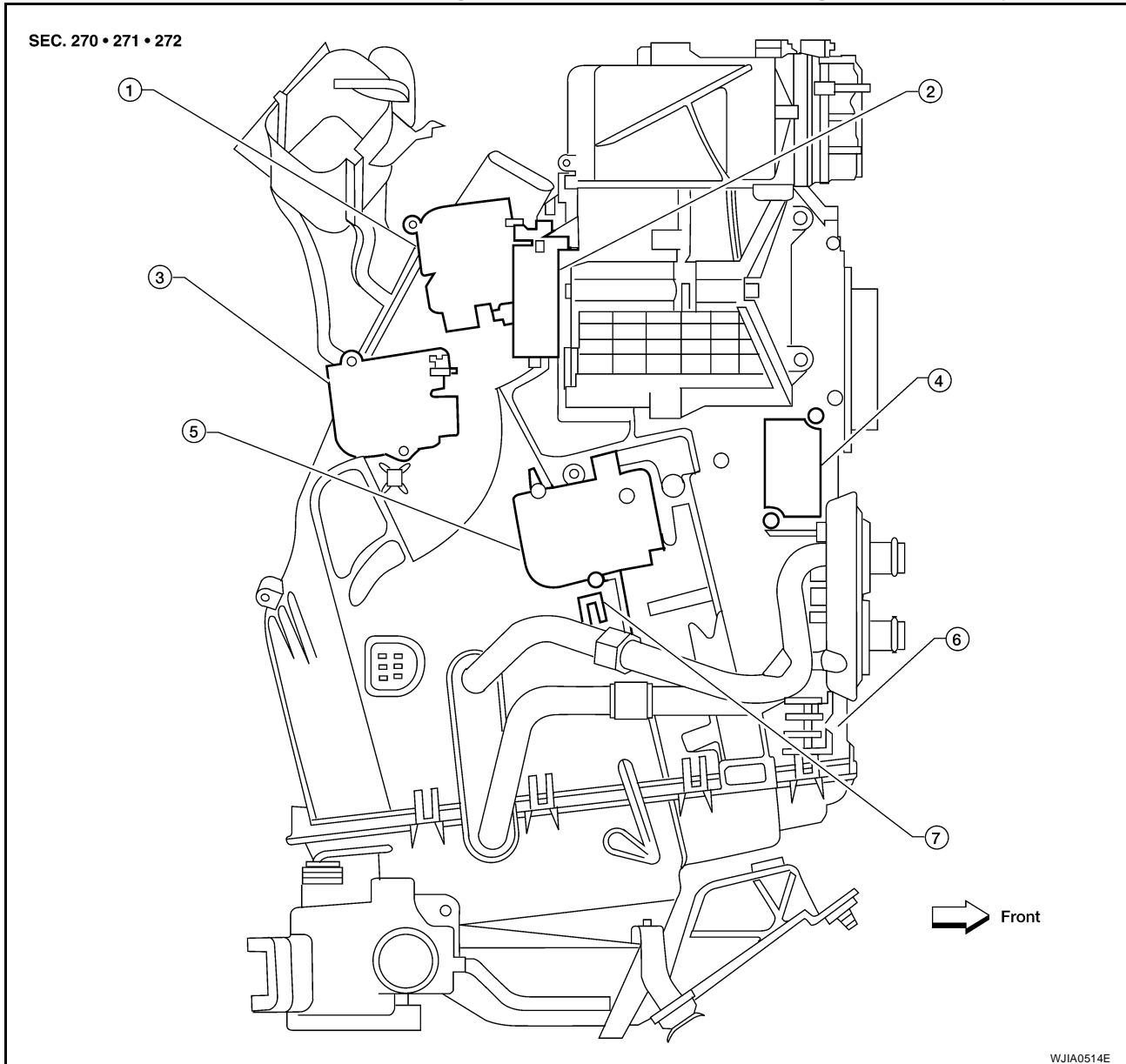

- | | | |
|------------------------------------|-----------------------------------|---|
| 1. Defroster door motor | 2. Intake door motor (passenger) | 3. Mode door motor |
| 4. Variable blower control (front) | 5. Air mix door motor (passenger) | 6. Front heater and cooling unit assembly |
| 7. Intake sensor | | |

Removal and Installation FRONT AIR MIX DOOR MOTOR (DRIVER)

EJS004L0

Removal

1. Remove the instrument lower panel LH. Refer to [IP-12, "Instrument Lower Panel LH"](#) .
2. Remove the center stack. Refer to [IP-13, "Center Stack Trim Panel"](#) .

AIR MIX DOOR MOTOR

3. Disconnect the air mix door motor electrical connector.
4. Remove the three screws and remove the air mix door motor.

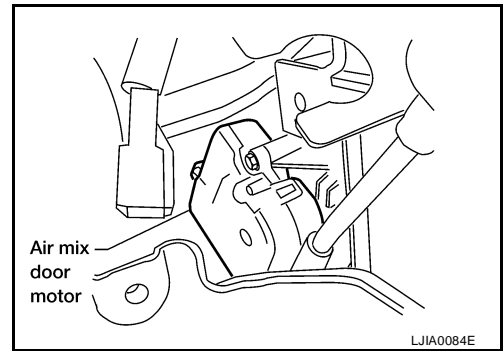

Installation

Installation is in the reverse order of removal.

FRONT AIR MIX DOOR MOTOR (PASSENGER)

Removal

1. Remove the front heater and cooling unit assembly. Refer to [ATC-170, "FRONT HEATER AND COOLING UNIT ASSEMBLY"](#).
2. Remove the steering member from the front heater and cooling unit assembly.
3. Disconnect the air mix door motor electrical connector.
4. Remove the three screws and remove the air mix door motor.

Installation

Installation is in the reverse order of removal.

REAR AIR MIX DOOR MOTOR

Removal

1. Remove the rear lower finisher assembly. Refer to [EI-35, "RIGHT SIDE AND REAR"](#).
2. Disconnect the rear air mix door motor electrical connector.
3. Remove the three screws and remove the rear air mix door motor.

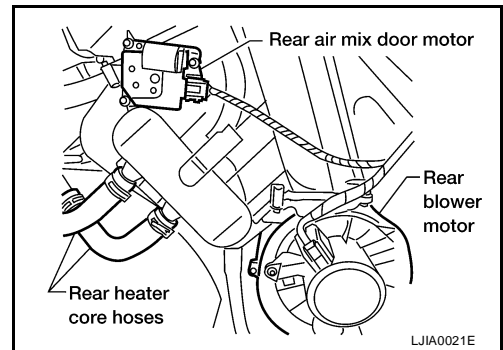

Installation

Installation is in the reverse order of removal.

VARIABLE BLOWER CONTROL

VARIABLE BLOWER CONTROL

PFP:27200

Components

EJS0053G

Variable Blower Control (Front)

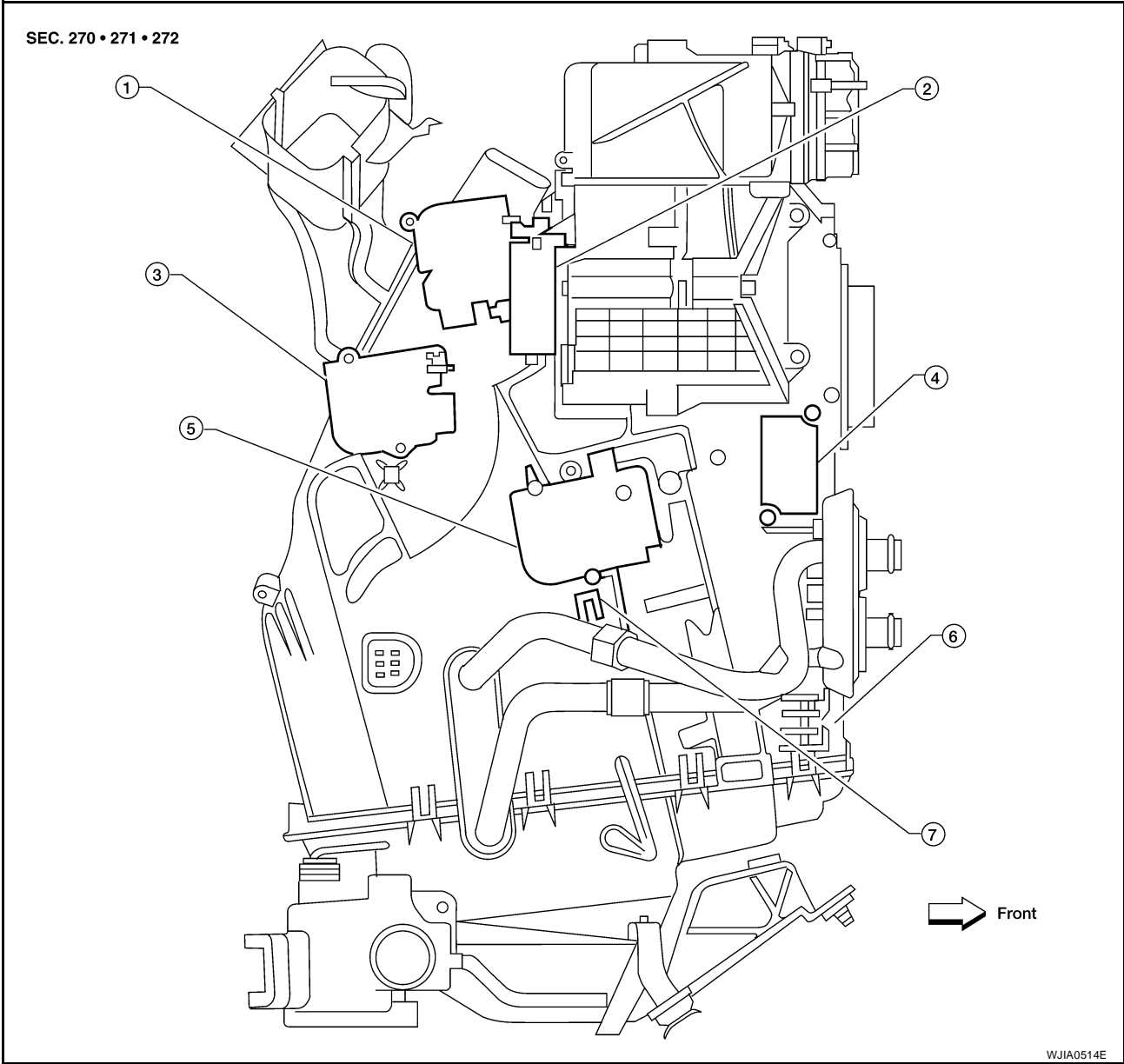

- 1. Defroster door motor
- 2. Intake door motor (passenger)
- 3. Mode door motor
- 4. Variable blower control (front)
- 5. Air mix door motor (passenger)
- 6. Front heater and cooling unit assembly
- 7. Intake sensor

A
B
C
D
E
F
G
H
I
ATC
K
L
M

VARIABLE BLOWER CONTROL

Variable Blower Control (Rear)

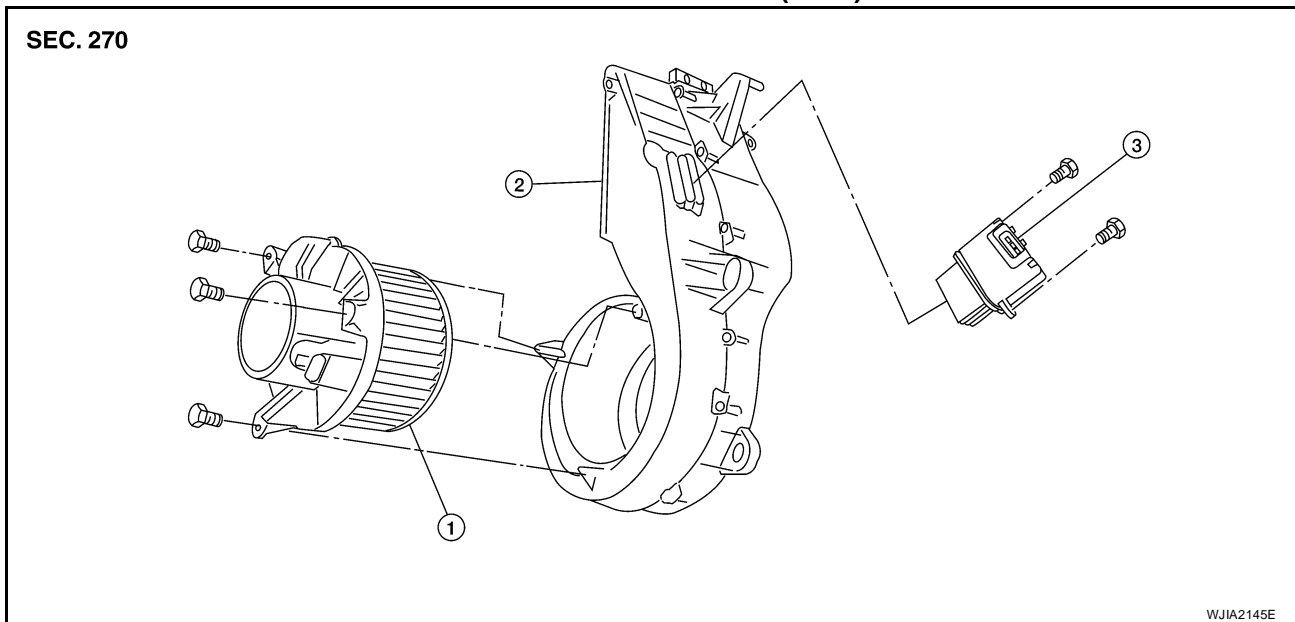

1. Rear blower motor

2. Rear blower motor case

3. Variable blower control (rear)

Removal and Installation VARIABLE BLOWER CONTROL (FRONT)

EJS004L1

Removal

1. Remove the instrument lower panel RH and glove box. Refer to [IP-14, "Glove Box"](#).
2. Remove the center stack. Refer to [IP-13, "Center Stack Trim Panel"](#).
3. Disconnect the variable blower control (front) electrical connector.
4. Remove the two screws and remove the variable blower control (front).

Installation

Installation is in the reverse order of removal.

VARIABLE BLOWER CONTROL (REAR)

Removal

1. Remove the rear heater and cooling unit assembly. Refer to [ATC-171, "REAR HEATER AND COOLING UNIT ASSEMBLY"](#).
2. Remove the two variable blower control (rear) screws.
3. Remove the variable blower control (rear).

Installation

Installation is in the reverse order of removal.

DUCTS AND GRILLES

DUCTS AND GRILLES

PF2:27860

Components

EJS004L3

Ducts - Front Heater and Cooling Unit Assembly

SEC. 270 273

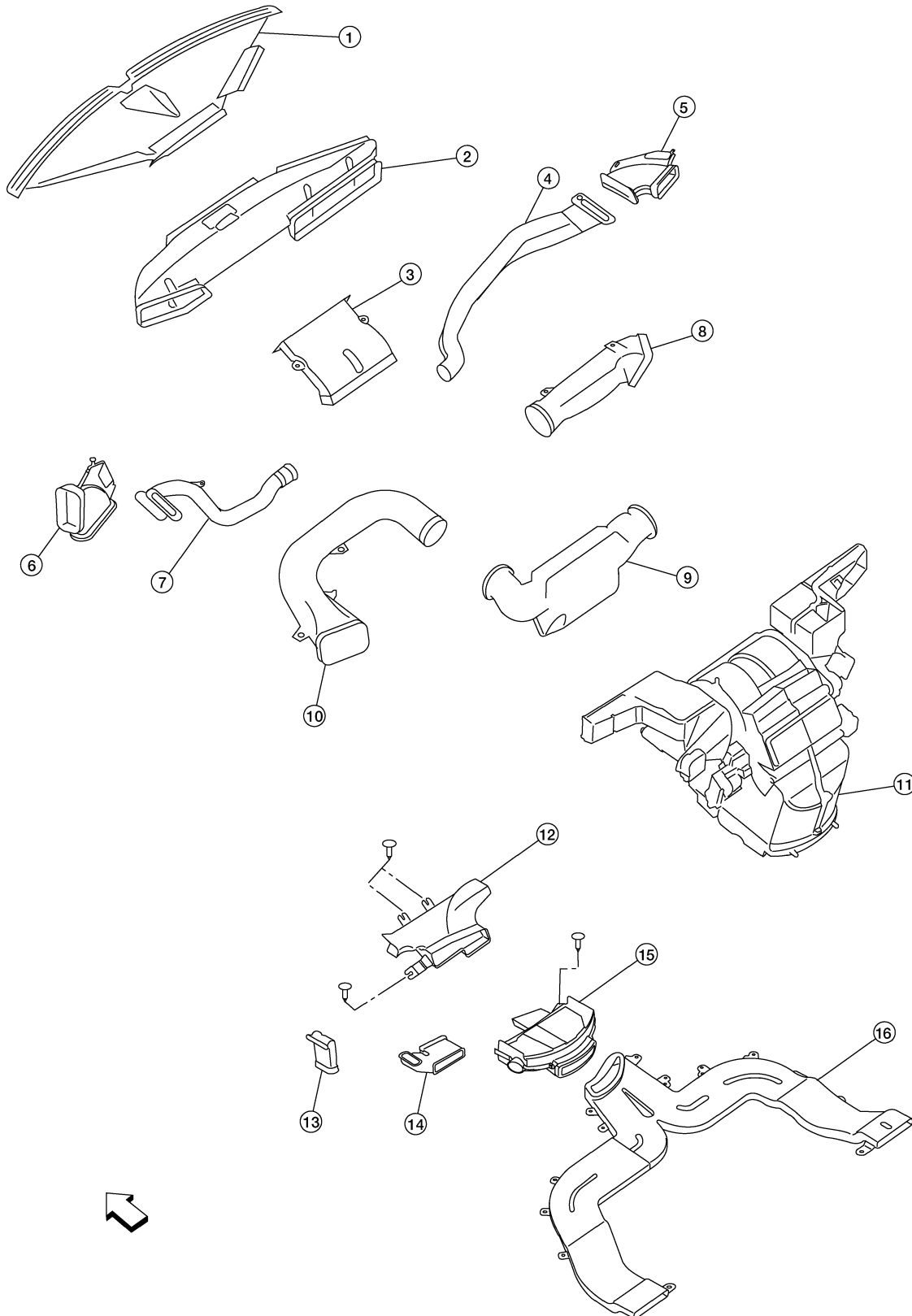

A
B
C
D
E
F
G
H
I
ATC
K
L
M

DUCTS AND GRILLES

- | | | |
|--|--|------------------------------------|
| 1. Defroster nozzle (part of the instrument panel) | 2. Fresh air duct | 3. Defroster duct |
| 4. RH side demister duct | 5. RH side demister duct extension | 6. LH side demister duct extension |
| 7. LH side demister duct | 8. RH ventilator duct | 9. Center ventilator duct |
| 10. LH ventilator duct | 11. Front heater and cooling unit assembly | 12. Floor connector duct |
| 13. Floor junction duct extension | 14. Floor junction duct | 15. Floor distribution duct |
| 16. Floor duct | | ⇐ Front |

Ducts - Rear Heater and Cooling Unit Assembly

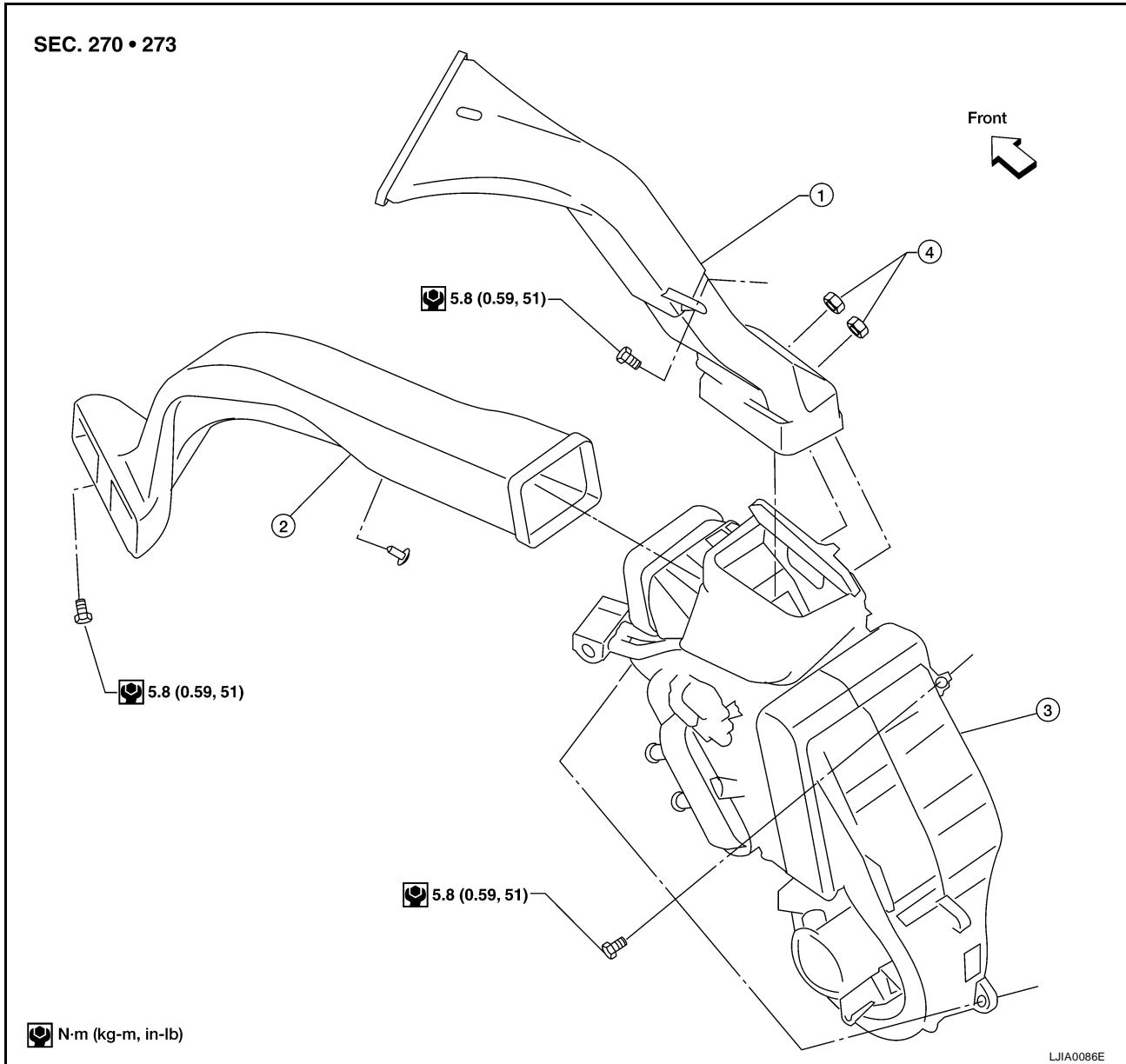

- | | | |
|-----------------------|--------------------|--|
| 1. Rear overhead duct | 2. Rear floor duct | 3. Rear heater and cooling unit assembly |
| 4. Clips | | |

DUCTS AND GRILLES

Grilles

SEC. 685 • 970

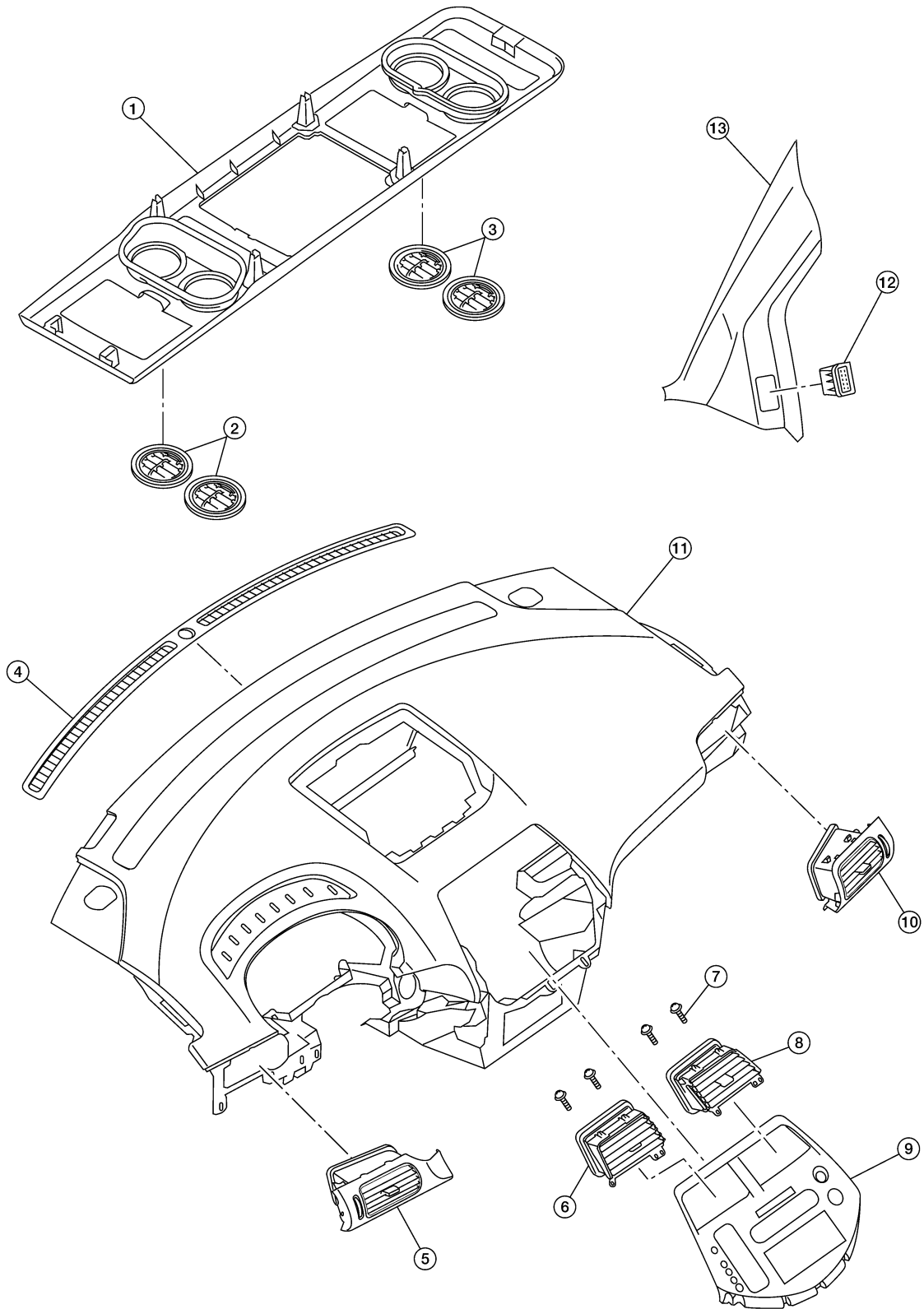

- 1. Overhead console
- 4. Front demister grille

- 2. Overhead console front grilles
- 5. LH ventilator grille

- 3. Overhead console rear grilles
- 6. Center LH ventilator grille

LJIA0197E

A
B
C
D
E
F
G
H
I

ATC

K
L
M

DUCTS AND GRILLES

-
- | | | |
|------------------------------------|--------------------------------|-----------------------------|
| 7. Center ventilator grille screws | 8. Center RH ventilator grille | 9. Cluster lid C |
| 10. RH ventilator grille | 11. Instrument panel | 12. RH side demister grille |
| 13. Front pillar finisher RH | | |

Removal and Installation DEFROSTER NOZZLE

EJS004L4

NOTE:

The defroster nozzle is part of the instrument panel and is replaced as an assembly.

Removal

Remove the instrument panel. Refer to [IP-10, "Instrument Panel"](#).

Installation

Installation is in the reverse order of removal.

FRESH AIR DUCT

Removal

1. Remove the front heater and cooling unit assembly. Refer to [ATC-170, "FRONT HEATER AND COOLING UNIT ASSEMBLY"](#).
2. Remove the defroster nozzle.
3. Remove the fresh air duct.

Installation

Installation is in the reverse order of removal.

DEFROSTER DUCT

Removal

1. Remove the instrument panel. Refer to [IP-10, "Instrument Panel"](#).
2. Remove the defroster duct.

Installation

Installation is in the reverse order of removal.

RH AND LH SIDE DEMISTER DUCT

Removal

1. Remove the instrument panel. Refer to [IP-10, "Instrument Panel"](#).
2. Remove the RH or LH side demister duct.

Installation

Installation is in the reverse order of removal.

RH, LH, AND CENTER VENTILATOR DUCT

Removal

1. Remove the instrument panel. Refer to [IP-10, "Instrument Panel"](#).
2. Remove the RH, center, and LH ventilator duct.

Installation

Installation is in the reverse order of removal.

FLOOR CONNECTOR DUCT

Removal

1. Remove the front heater and cooling unit assembly. Refer to [ATC-170, "FRONT HEATER AND COOLING UNIT ASSEMBLY"](#).
2. Remove the three clips and remove the floor connector duct.

Installation

Installation is in the reverse order of removal.

DUCTS AND GRILLES

FLOOR DISTRIBUTION DUCT

Removal

1. Remove the center lower trim. Refer to [IP-10, "Instrument Panel"](#) .
2. Remove the clip and remove the floor distribution duct.

Installation

Installation is in the reverse order of removal.

FLOOR JUNCTION DUCT

Removal

1. Remove the center lower trim. Refer to [IP-10, "Instrument Panel"](#) .
2. Remove the clip and remove the floor distribution duct.
3. Remove the floor junction duct.

Installation

Installation is in the reverse order of removal.

FLOOR JUNCTION DUCT EXTENSION

Removal

1. Remove the center lower trim. Refer to [IP-10, "Instrument Panel"](#) .
2. Remove the clip and remove the floor junction duct extension.

Installation

Installation is in the reverse order of removal.

FLOOR DUCT

Removal

1. Remove the floor carpet. Refer to [EI-39, "FLOOR TRIM"](#) .
2. Remove the floor duct.

Installation

Installation is in the reverse order of removal.

REAR OVERHEAD DUCT

Removal

1. Remove the rear lower finisher assembly. Refer to [EI-33, "Removal and Installation"](#) .
2. Remove the headliner. Refer to [EI-25, "Removal and Installation"](#) .

NOTE:

The rear headliner duct connected to the rear overhead duct is part of the headlining trim panel and is replaced as an assembly. Refer to [EI-41, "HEADLINING"](#) .

3. Remove the bolt and two clips, and remove the rear overhead duct.

Installation

Installation is in the reverse order of removal.

REAR FLOOR DUCT

Removal

1. Remove the rear lower finisher assembly. Refer to [EI-33, "Removal and Installation"](#) .
2. Reposition the floor carpet out of the way.
3. Remove the screw and clip, then remove the rear floor duct.

Installation

Installation is in the reverse order of removal.

GRILLES

Removal

1. Remove the interior trim panel(s) as necessary that contains the grille to be removed. Refer to [EI-33, "BODY SIDE TRIM"](#) or [EI-41, "HEADLINING"](#) .
2. Remove the grille from the interior trim panel.

A

B

C

D

E

F

G

H

I

ATC

K

L

M

DUCTS AND GRILLES

Installation

Installation is in the reverse order of removal.

REFRIGERANT LINES

PFP:92600

HFC-134a (R-134a) Service Procedure SETTING OF SERVICE TOOLS AND EQUIPMENT

EJS004L5

Discharging Refrigerant

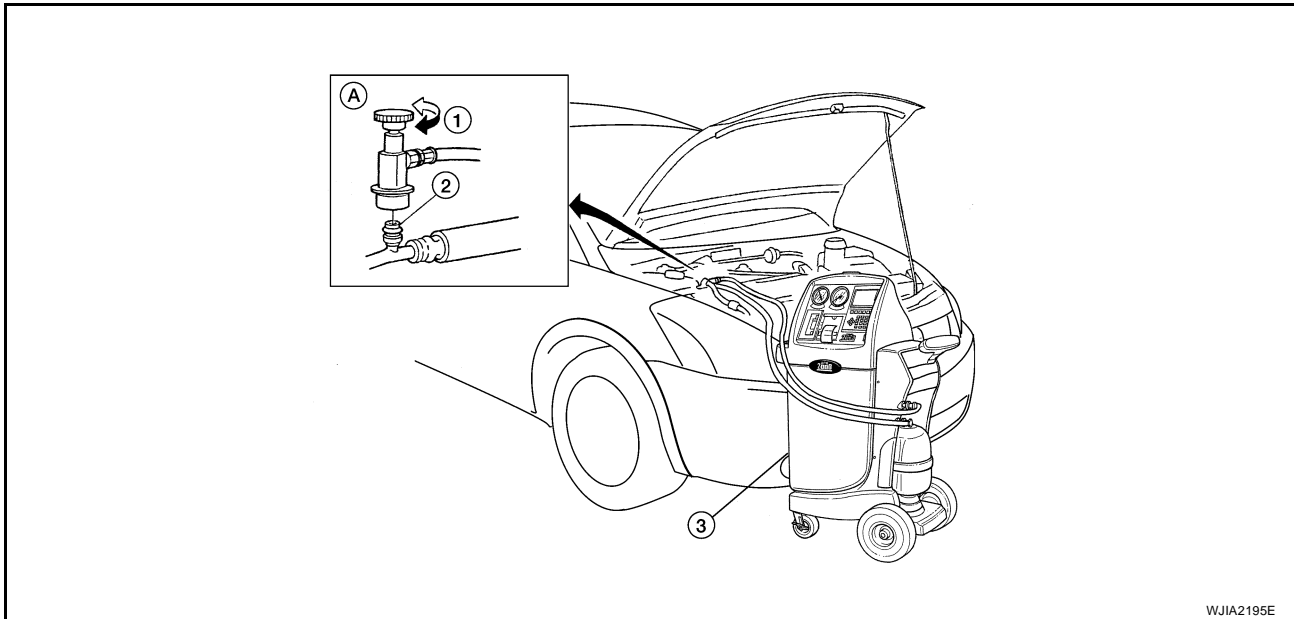

- 1. Shut-off valve
- 2. A/C service valve
- 3. Recovery/recycling equipment
- A. Preferred (best) method

WARNING:

Avoid breathing A/C refrigerant and oil vapor or mist. Exposure may irritate eyes, nose and throat. Remove HFC-134a (R-134a) refrigerant from the A/C system using certified service equipment meeting requirements of SAE J2210 HFC-134a (R-134a) recycling equipment or SAE J2201 HFC-134a (R-134a) recovery equipment. If an accidental system discharge occurs, ventilate the work area before resuming service. Additional health and safety information may be obtained from the refrigerant and oil manufacturers.

ATC

Evacuating System and Charging Refrigerant

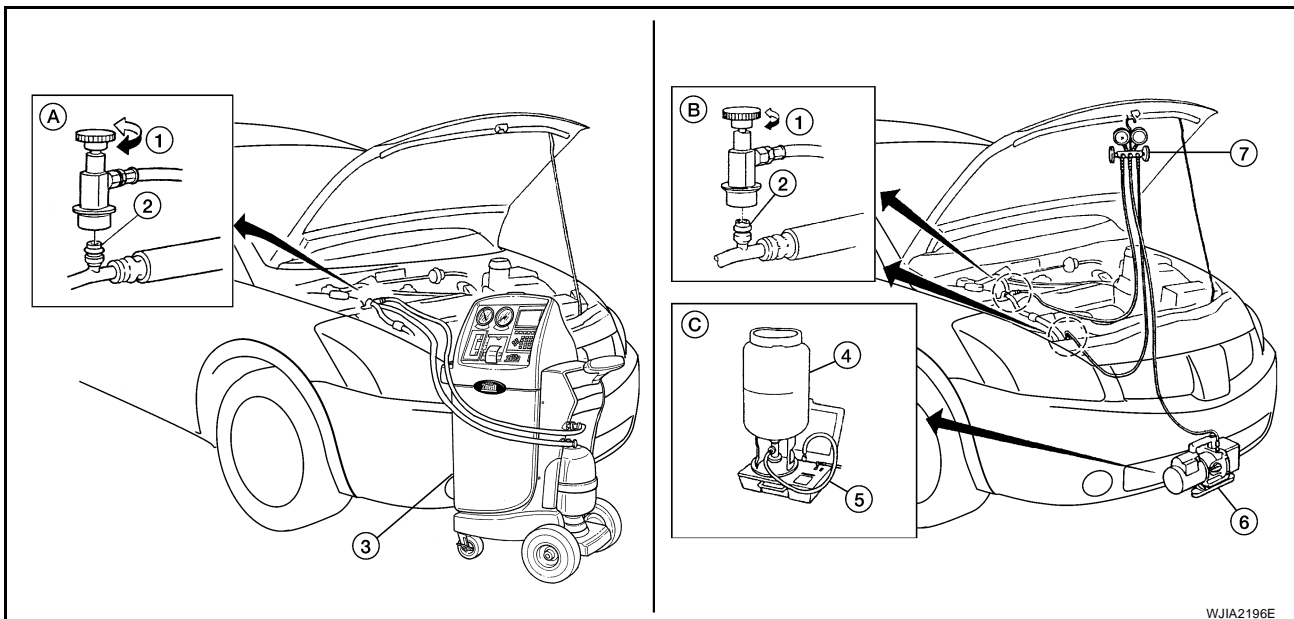

- 1. Shut-off valve
- 2. A/C service valve
- 3. Recovery/recycling equipment
- 4. Refrigerant container (HFC-134a)
- 5. Weight scale (J-39650)
- 6. Evacuating vacuum pump (J-39699)

REFRIGERANT LINES

7. Manifold gauge set (J-39183) A. Preferred (best) method B. Alternative method
 C. For charging

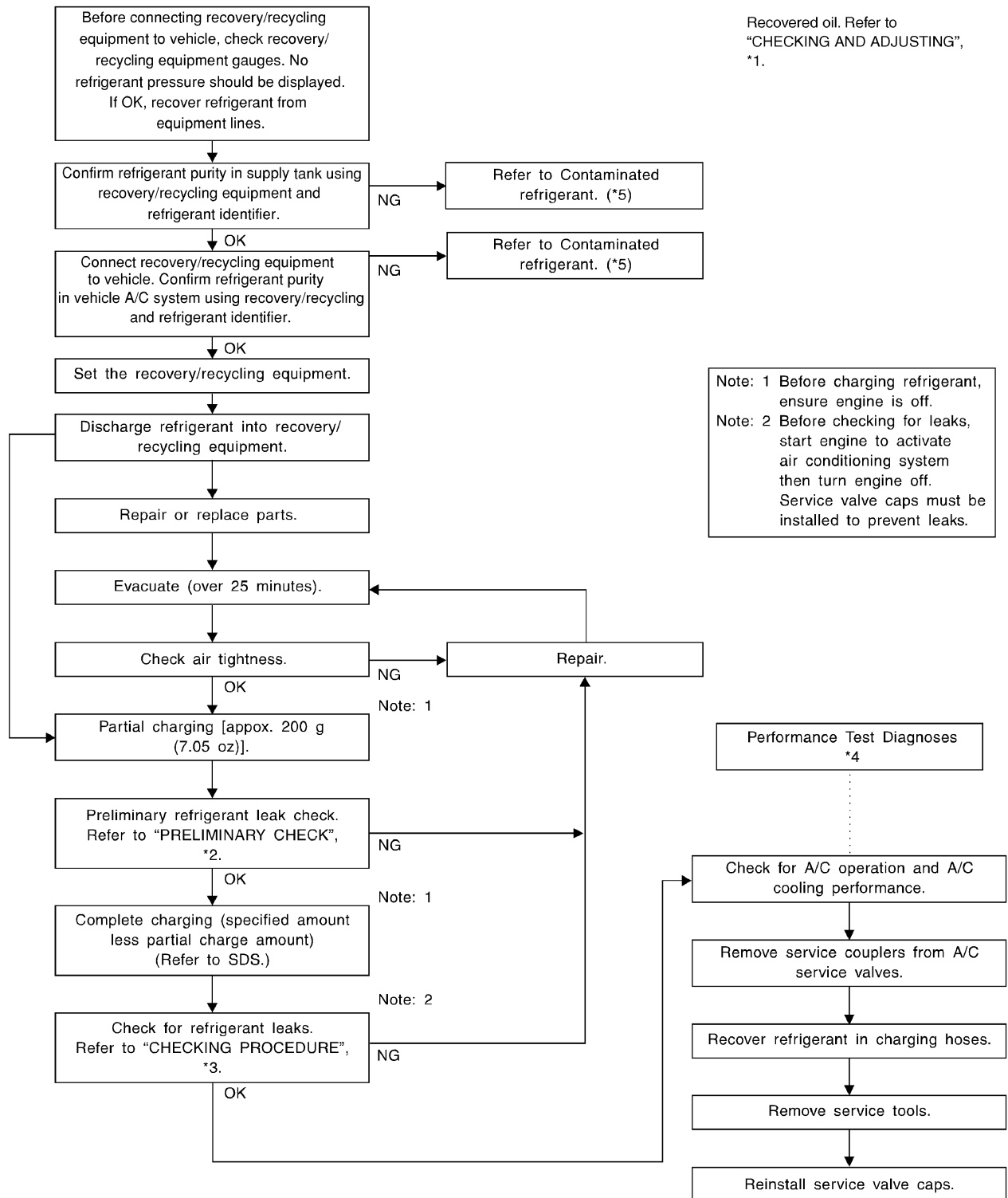

- 1 [ATC-22, "CHECKING AND ADJUSTING"](#) . 3 [ATC-212, "Checking for Refrigerant Leaks"](#). 5 [ATC-5, "Contaminated Refrigerant"](#).
 2 [ATC-212, "Checking for Refrigerant Leaks"](#). 4 [ATC-132, "PERFORMANCE TEST DIAGNOSES"](#).

WJIA1923E

REFRIGERANT LINES

EJS004L6

Components

Front A/C Compressor and Condenser

SEC. 214 • 271 • 274 • 276

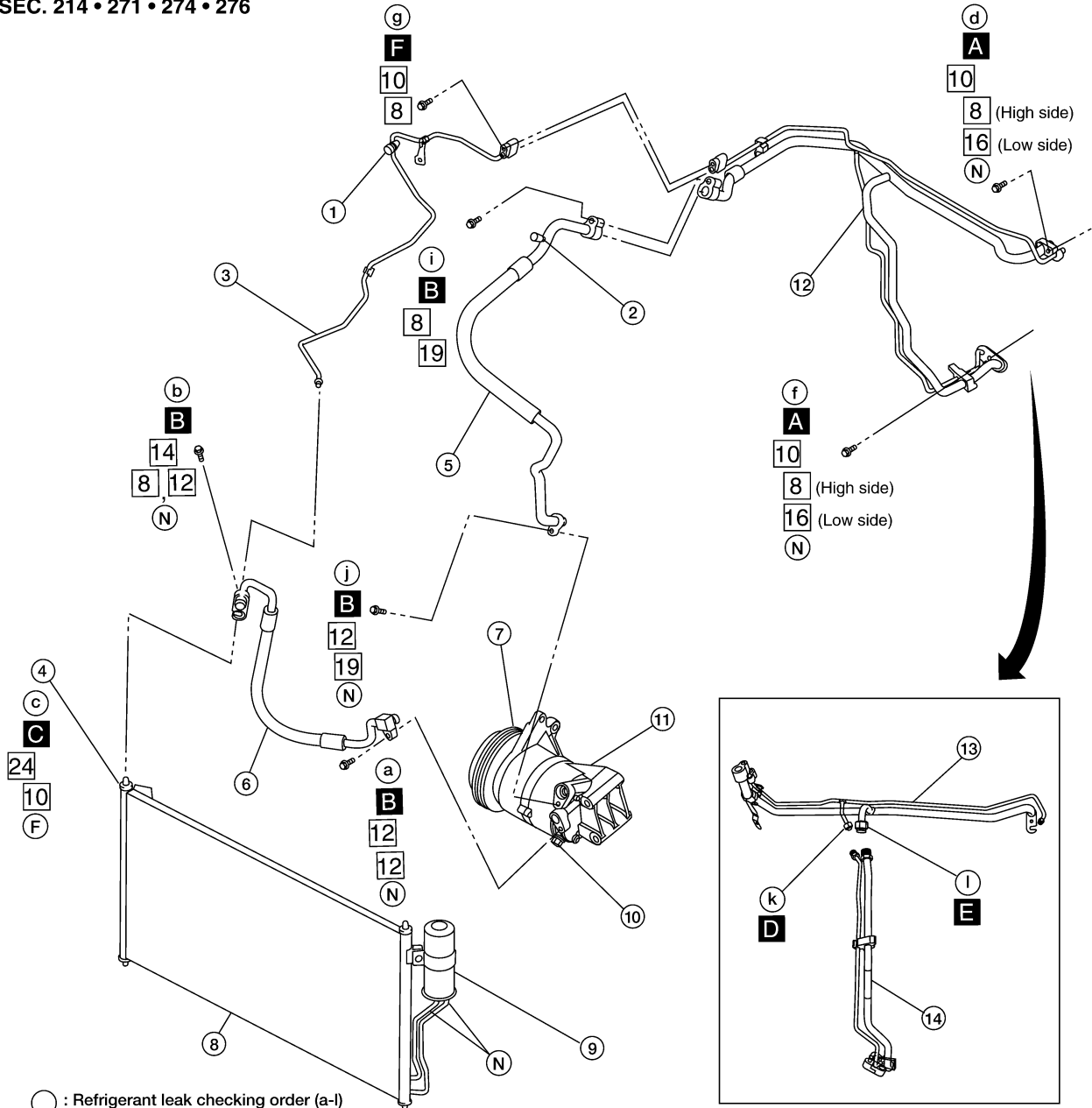

- : Refrigerant leak checking order (a-l)
- : Tightening torque
- : Wrench size
- : O-ring size
- ⊙ : N-m (kg-m, in-lb)
- ⊙ : N-m (kg-m, ft-lb)
- A** ⊙ : 6.8 (0.69, 60)
- B** ⊙ : 14.2 (1.4, 10)
- C** ⊙ : 10.8 (1.1, 8)
- D** ⊙ : 18 (1.8, 13)
- E** ⊙ : 31 (3.2, 23)
- F** ⊙ : 5.7 (0.58, 50)
- ⊙ (F) : Former type refrigerant connection
- ⊙ (N) : New type refrigerant connection

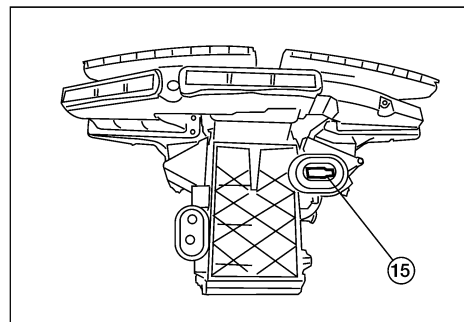
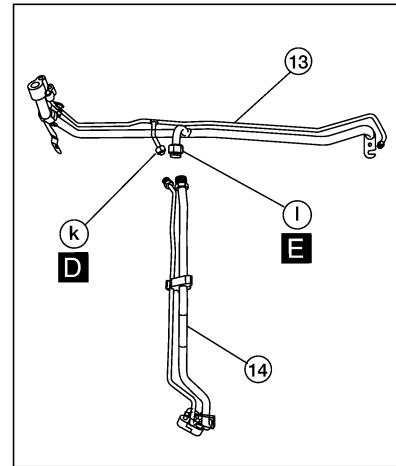

A
B
C
D
E
F
G
H
I
ATC
K
L
M

REFRIGERANT LINES

- | | | |
|--|--|---|
| 1. High-pressure service valve | 2. Low-pressure service valve | 3. High-pressure pipe |
| 4. Refrigerant pressure sensor | 5. Low-pressure flexible hose | 6. High-pressure flexible hose |
| 7. Shaft seal | 8. Condenser | 9. Liquid tank |
| 10. Pressure relief valve | 11. Compressor | 12. High/low pressure pipe (production) |
| 13. High/low pressure pipe - upper (service) | 14. High/low pressure pipe - lower (service) | 15. Expansion valve (front) |

Rear A/C

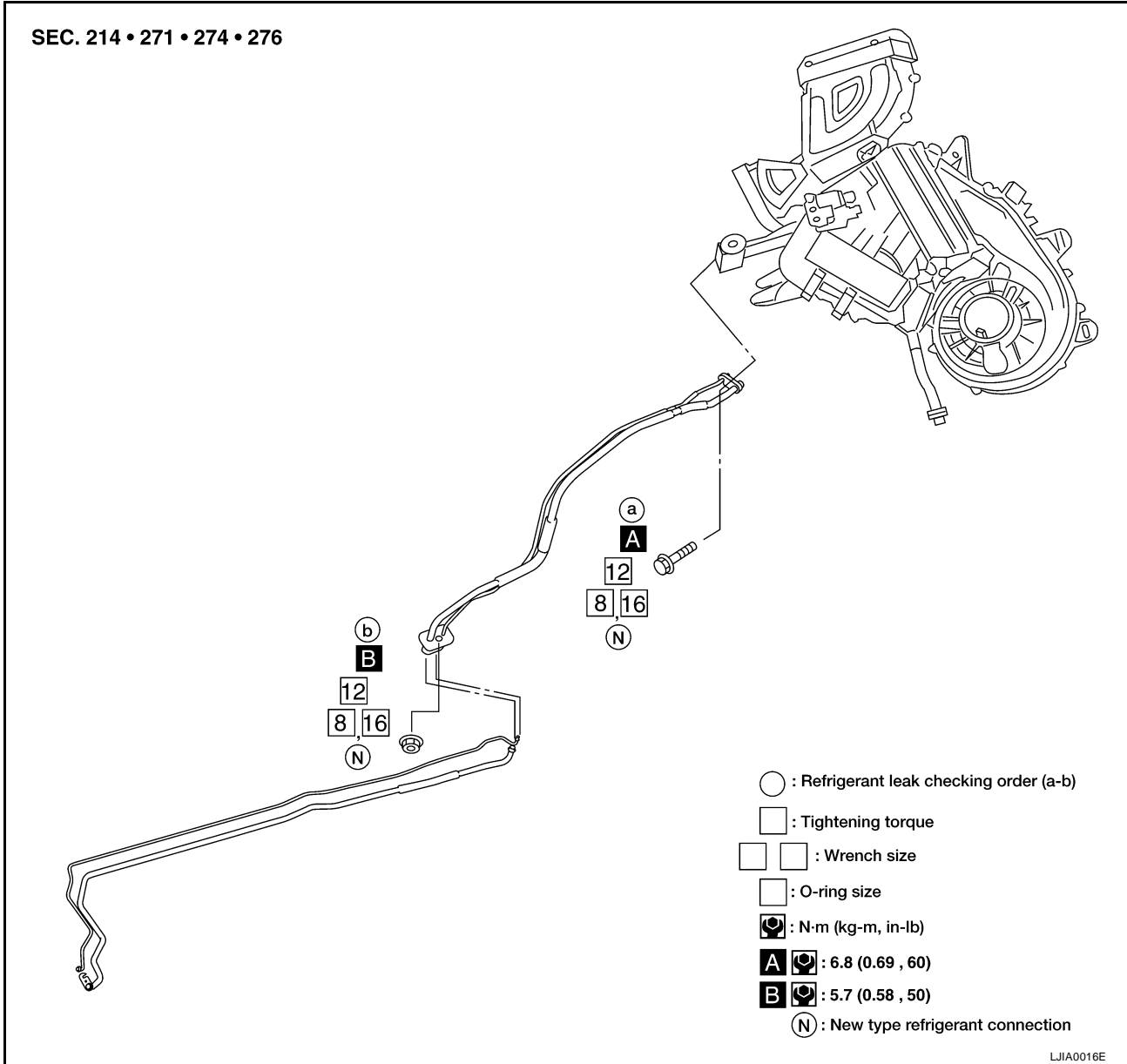

CAUTION:

The new and former refrigerant connections use different O-ring configurations. Do not confuse O-rings since they are not interchangeable. If a wrong O-ring is installed, refrigerant will leak at or around the connection.

REFRIGERANT LINES

Removal and Installation for Compressor

EJS004L7

Compressor Mounting

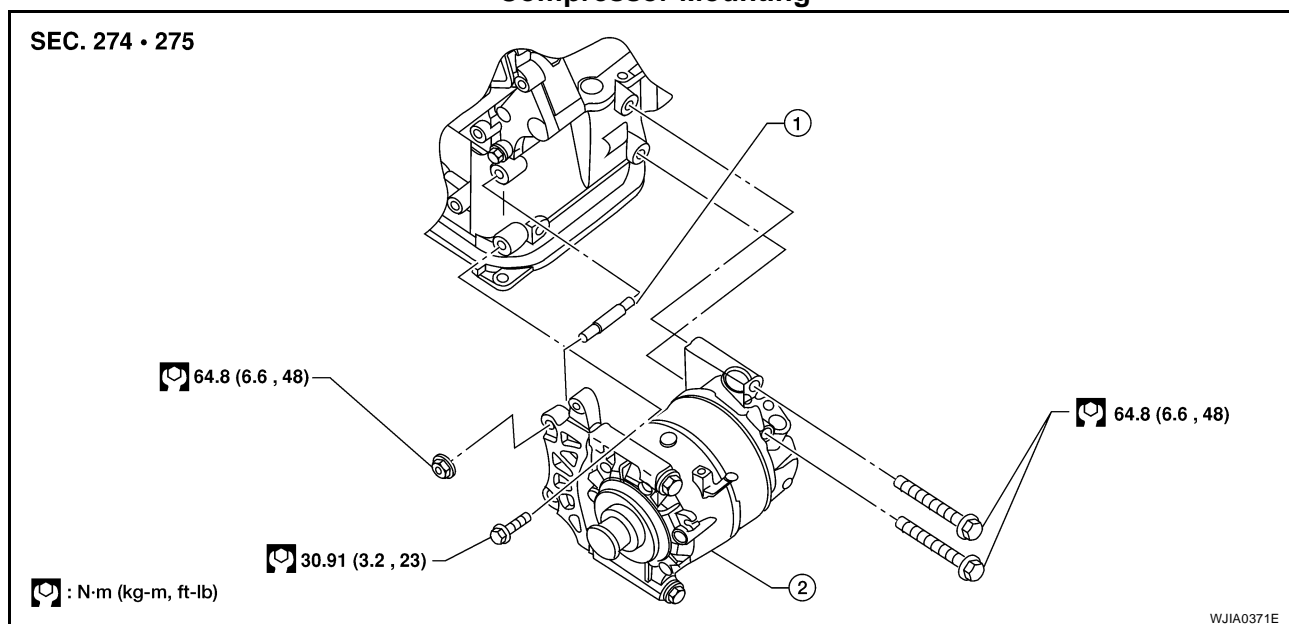

REMOVAL

1. Discharge the refrigerant. Refer to [ATC-193, "HFC-134a \(R-134a\) Service Procedure"](#).
2. Remove the engine under cover and the splash shield.
3. Remove the drive belt. Refer to [MA-11, "Drive Belts"](#).
4. Remove the compressor mounting stud.
5. Disconnect the compressor connector.
6. Disconnect the high-pressure flexible hose and low-pressure flexible hose from the compressor.

CAUTION:

Cap or wrap the joint of the pipe with suitable material such as vinyl tape to avoid the entry of air.

7. Remove the compressor bolts and nut using power tools.

INSTALLATION

Installation is in the reverse order of removal.

CAUTION:

- Replace the O-ring of the low-pressure flexible hose and high-pressure flexible hose with a new one, then apply compressor oil to it when installing it.
- After charging refrigerant, check for leaks.

REFRIGERANT LINES

EJS004L8

Removal and Installation for Compressor Clutch

Magnet Clutch Assembly

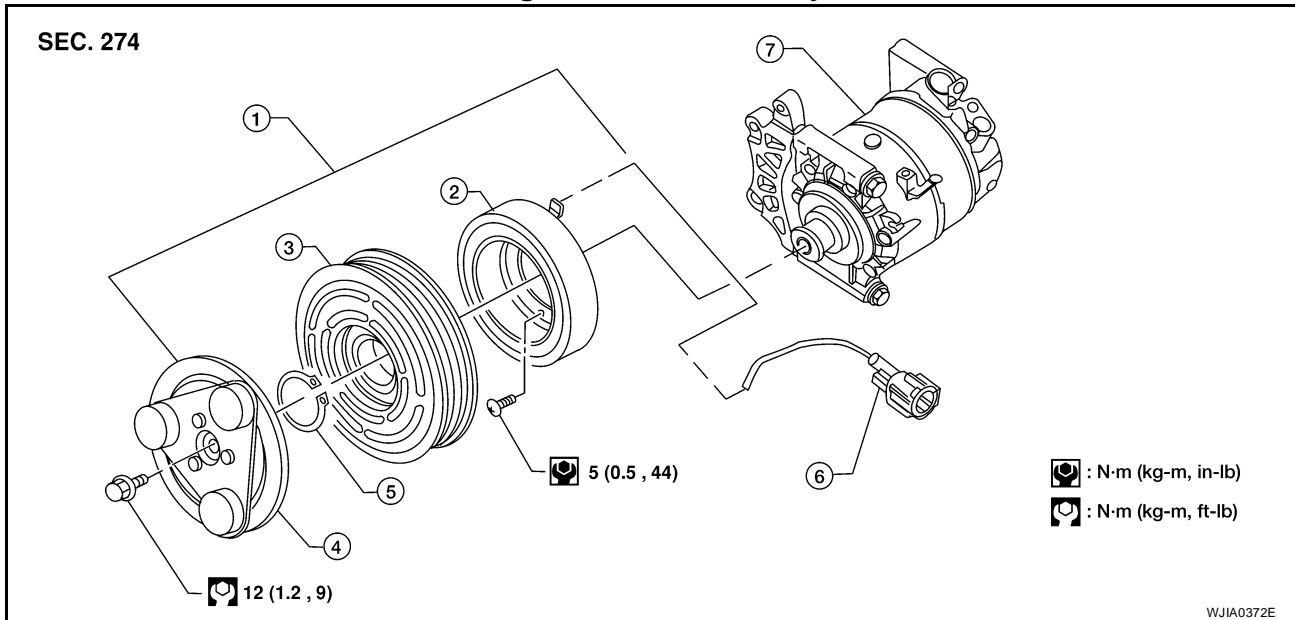

1. Magnet clutch assembly
2. Magnet coil
3. Pulley
4. Clutch disc
5. Snap ring
6. Thermal protector (built in)
7. Compressor

REMOVAL

NOTE:

For clarity, the compressor is shown out of the vehicle, but the compressor does not need to be removed to remove the compressor clutch.

1. Remove the engine under cover and the splash shield.
2. Remove the drive belt. Refer to [MA-11, "Drive Belts"](#).
3. Disconnect the compressor electrical connector.
4. Remove the center bolt while holding the clutch disc stationary using Tool as shown.

Tool number : J-44614

5. Remove the clutch disc.

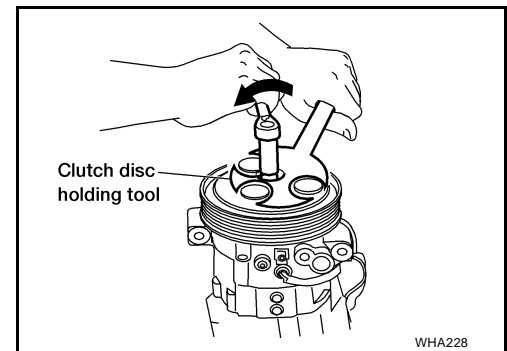

6. Remove the snap ring using external snap ring pliers or suitable tool.

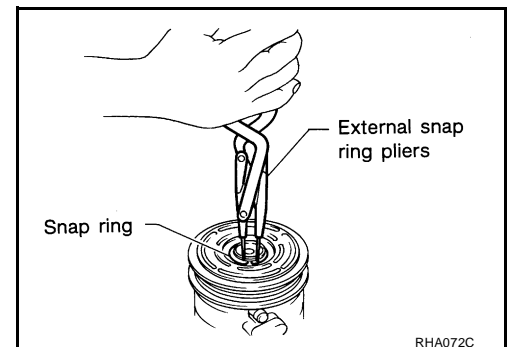

REFRIGERANT LINES

- Remove the pulley using Tool with a small adapter. Position the small adapter on the end of the drive shaft and the center of the puller on the small adapter.

Tool number : KV99233130 (J-29884)

CAUTION:

To prevent deformation of the pulley groove, the puller claws should be hooked under the pulley groove and not into the pulley groove.

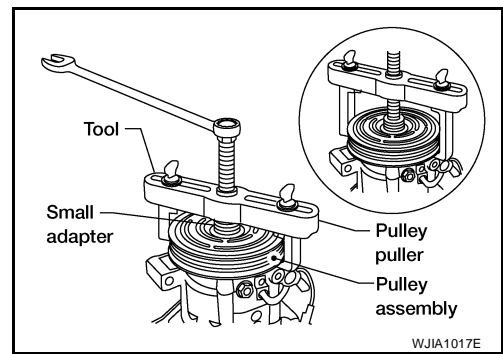

- Remove the magnet coil harness clip using a screwdriver.

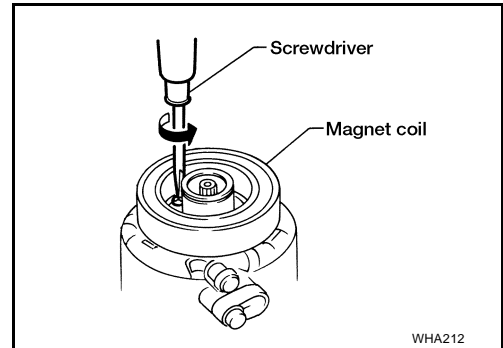

- Remove the three magnet coil fixing screws and remove the magnet coil.

INSPECTION

Clutch Disc

If the contact surface shows signs of damage due to excessive heat, replace clutch disc and pulley.

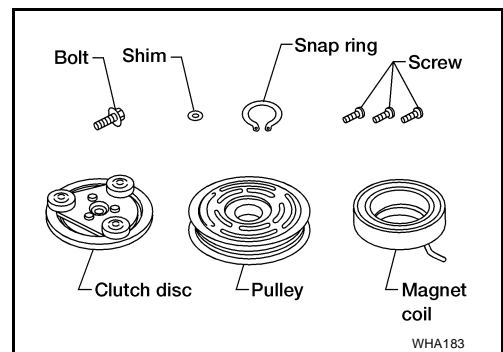

Pulley

Check the appearance of the pulley assembly. If contact surface of pulley shows signs of excessive grooving, replace clutch disc and pulley. The contact surfaces of the pulley assembly should be cleaned with a suitable solvent before reinstallation.

Coil

Check magnet coil for loose connections or any cracked insulation.

INSTALLATION

- Install the magnet coil.

CAUTION:

Be sure to align the magnet coil pin with the hole in the compressor front head.

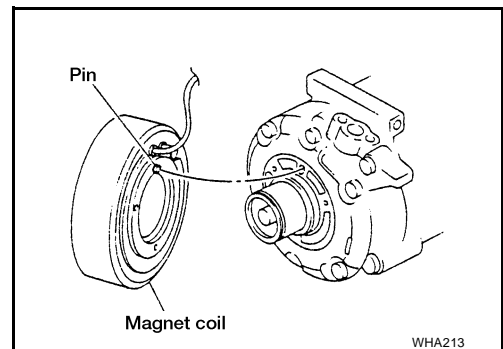

A
B
C
D
E
F
G
H
I
K
L
M

ATC

REFRIGERANT LINES

2. Install the magnet coil harness clip using a screwdriver.
3. Install the pulley assembly using Tool and a wrench, then install the snap ring using snap ring pliers.

Tool number : — (J-38873-A)

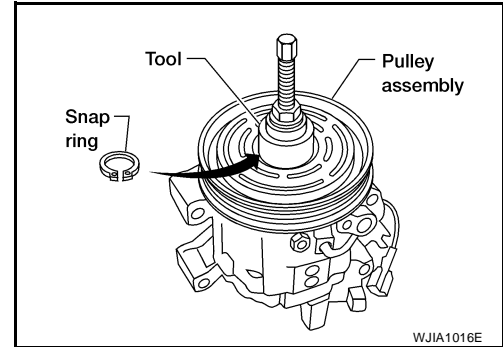

4. Install the clutch disc on the compressor shaft, together with the original shim(s). Press the clutch disc down by hand.

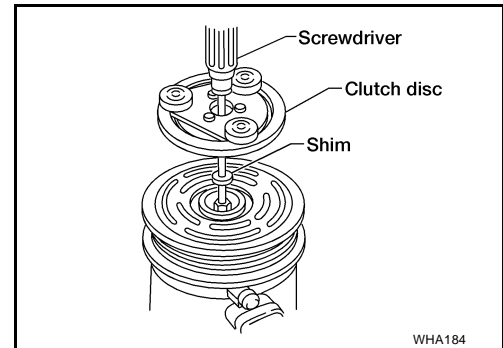

5. Install the clutch pulley bolt using Tool, to prevent the clutch disc from turning and tighten the bolt to specification. Refer to [ATC-195, "Components"](#).

Tool number : J-44614

CAUTION:

After tightening the clutch pulley bolt, check that the clutch pulley rotates smoothly.

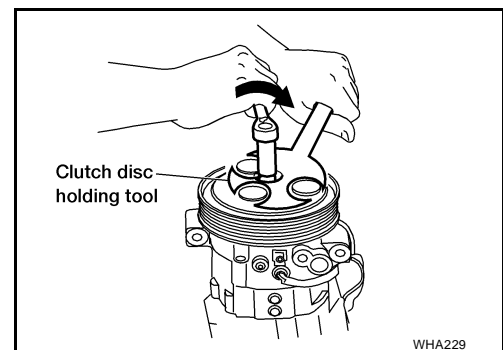

REFRIGERANT LINES

6. Check the pulley clearance all the way around the clutch disc as shown.

**Clutch disc-to-pulley clearance : 0.3 - 0.6 mm
(0.012 - 0.024 in)**

7. If the specified clearance is not obtained, replace the adjusting spacer to readjust.
8. Connect the compressor electrical connector.
9. Install the drive belt.
Refer to [MA-11, "Drive Belts"](#) .
10. Install the engine under cover and the splash shield.

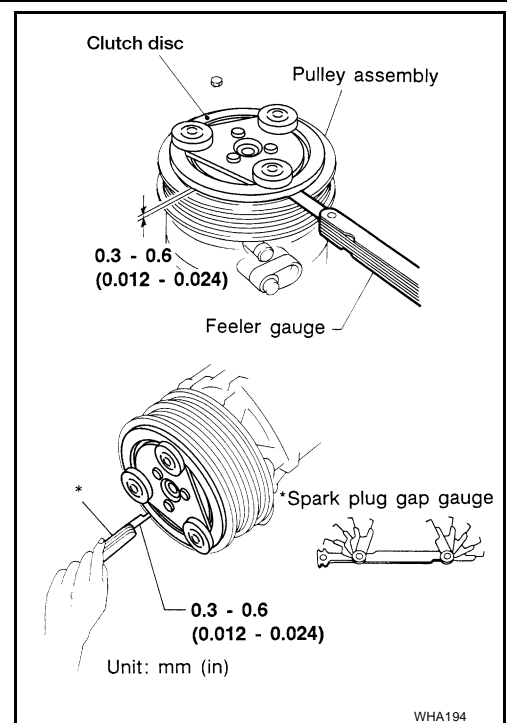

BREAK-IN OPERATION

When replacing compressor clutch assembly, always conduct the break-in operation. This is done by engaging and disengaging the clutch about 30 times. Break-in operation raises the level of transmitted torque.

Removal and Installation for Low-pressure Flexible Hose

EJS004L9

REMOVAL

1. Remove the engine under cover.
2. Discharge the refrigerant. Refer to [ATC-193, "HFC-134a \(R-134a\) Service Procedure"](#) .

CAUTION:

Cap or wrap the joint of the pipe with suitable material such as vinyl tape to avoid the entry of air.

3. Remove the low-pressure flexible hose. Refer to [ATC-195, "Components"](#) .

INSTALLATION

Installation is in the reverse order of removal.

Refer to [ATC-195, "Components"](#) .

CAUTION:

- Replace the O-ring of the low-pressure flexible hose with a new one, then apply compressor oil to it when installing it.
- After charging refrigerant, check for leaks.

Removal and Installation for High-pressure Flexible Hose

EJS004LA

REMOVAL

1. Remove the engine under cover.
2. Discharge the refrigerant. Refer to [ATC-193, "HFC-134a \(R-134a\) Service Procedure"](#) .
3. Remove the high-pressure flexible hose. Refer to [ATC-195, "Components"](#) .

CAUTION:

Cap or wrap the joint of the pipe with suitable material such as vinyl tape to avoid the entry of air.

INSTALLATION

Installation is in the reverse order of removal.

Refer to [ATC-195, "Components"](#) .

CAUTION:

- Replace the O-ring of the high-pressure flexible hose with a new one, then apply compressor oil to it when installing it.
- After charging refrigerant, check for leaks.

REFRIGERANT LINES

EJS004LB

Removal and Installation for High-pressure Pipe

REMOVAL

1. Reposition the IPDM E/R aside.
2. Remove the windshield washer fluid bottle filler neck.
3. Reposition the coolant reservoir tank aside.
4. Reposition the power steering fluid reservoir aside.
5. Discharge the refrigerant. Refer to [ATC-193, "HFC-134a \(R-134a\) Service Procedure"](#) .
6. Remove the high-pressure pipe. Refer to [ATC-195, "Components"](#) .

CAUTION:

Cap or wrap the joint of the pipe with suitable material such as vinyl tape to avoid the entry of air.

INSTALLATION

Installation is in the reverse order of removal.

Refer to [ATC-195, "Components"](#) .

CAUTION:

- Replace the O-ring of the high-pressure pipe with a new one, then apply compressor oil to it when installing it.
- After charging refrigerant, check for leaks.

Removal and Installation for High/Low-pressure Pipe

EJS0053A

REMOVAL

1. Discharge the refrigerant. Refer to [ATC-193, "HFC-134a \(R-134a\) Service Procedure"](#) .

WARNING:

- Avoid breathing the A/C refrigerant and oil vapor or mist. Exposure may irritate the eyes, nose and throat.
 - If an accidental system discharge occurs, ventilate the work area before resuming removal.
2. Remove the cowl top cover. Refer to [EI-19, "COWL TOP"](#) .
 3. Disconnect the ECM from the cowl top extension and reposition it out of the way.
 4. Remove the two heater pump clips from the cowl top extension and reposition the heater pump out of the way. Refer to [ATC-175, "HEATER PUMP"](#) .
 5. Disconnect the heater hose clips from the cowl top extension and reposition the heater hose out of the way.
 6. Remove the wiper motor and linkage. Refer to [WW-24, "Wiper Motor and Linkage"](#) .
 7. Remove the cowl top extension. Refer to [EI-19, "COWL TOP"](#) .
 8. Carefully cut the high pressure pipe (1) using a suitable ratchet-type pipe cutter (A) as shown.

CAUTION:

- Do NOT damage the hydraulic brake lines or any other surrounding parts when cutting the pipe.
- A small amount of refrigerant may discharge from the pipe when it is cut.
- Do not allow debris to fall into the cut ends of the pipe.

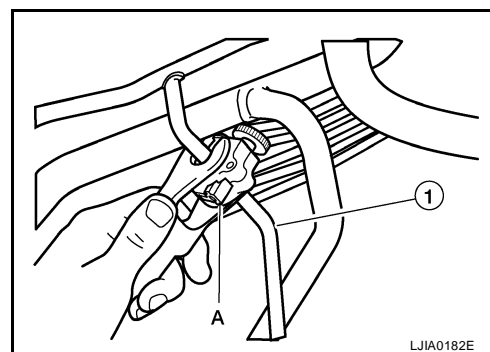

LJIA0182E

REFRIGERANT LINES

9. Carefully cut the low pressure pipe (1) using a suitable ratchet-type pipe cutter (A) as shown.

CAUTION:

- Do NOT damage the hydraulic brake lines or any other surrounding parts when cutting the pipe.
- A small amount of refrigerant may discharge from the pipe when it is cut.

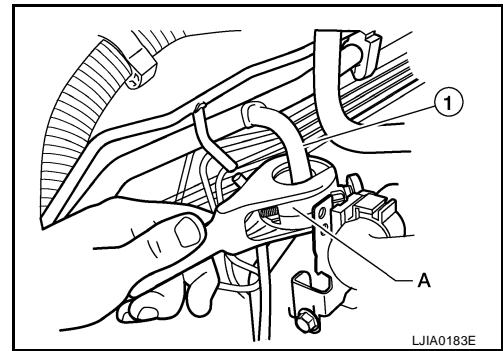

10. Disconnect the power brake booster vacuum hose from the intake manifold collector to allow removal of the cut A/C pipes.
11. Disconnect the high pressure pipe connection (1), low pressure pipe connection (2), and the A/C pipe clamp bolt (A) located near the RH front suspension strut tower (3) as shown.

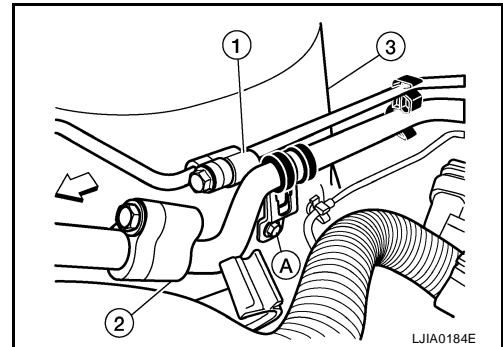

12. Disconnect the high/low pressure pipe connector bolt (1) from the front expansion valve as shown.
- Air cleaner to electric throttle control actuator tube (2)
 - Electric throttle control actuator (3)
 - ←: Front

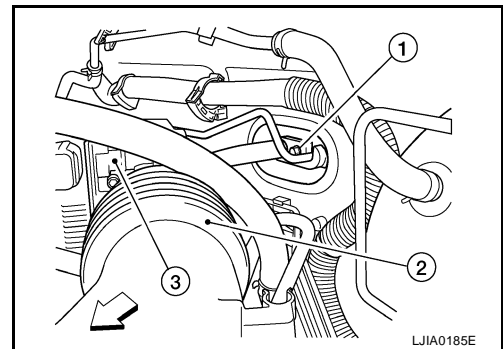

13. Use a suitable tool to pry the pipe support clip (1) from the threaded stud on the dash panel as shown.
- ←: Front

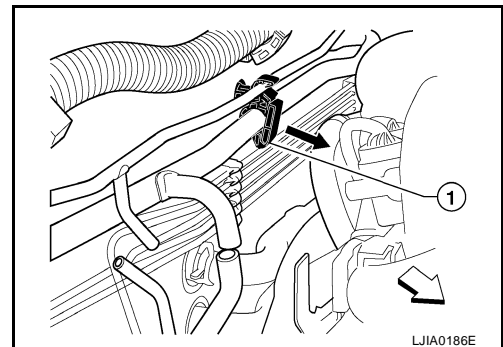

A
B
C
D
E
F
G
H
I
K
L
M

ATC

REFRIGERANT LINES

14. Remove the top section of the high/low pressure pipe (1) as shown.

● ⇐: Front

CAUTION:

Cap or wrap the open pipe connections with a suitable material such as vinyl tape to avoid the entry of air, moisture and contamination.

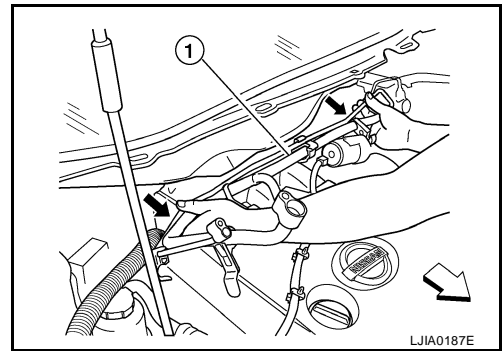

15. Remove the lower section of the high/low pressure pipe.
- Access the lower section of the high/low pressure pipe from under the vehicle.
 - Remove the high/low pressure pipe connection (1) bolt (A).
 - Remove the A/C pipe clamp bolt (B) to release the A/C pipe clamp (2).

NOTE:

Reposition the rear heater pipe clamp (3) for additional clearance to remove the lower section of the high/low pressure pipe as necessary.

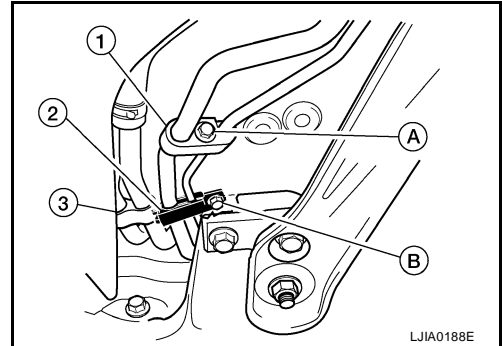

- Pry off the pipe support clip (1) secured to the dash panel threaded stud, using a suitable tool.

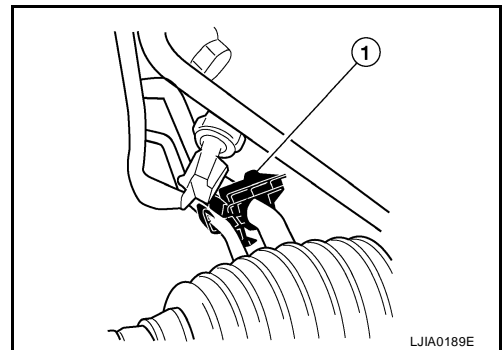

- Carefully remove the lower section of the high/low pressure pipe (1).

CAUTION:

Cap or wrap the open pipe connections with a suitable material such as vinyl tape to avoid the entry of air, moisture and contamination.

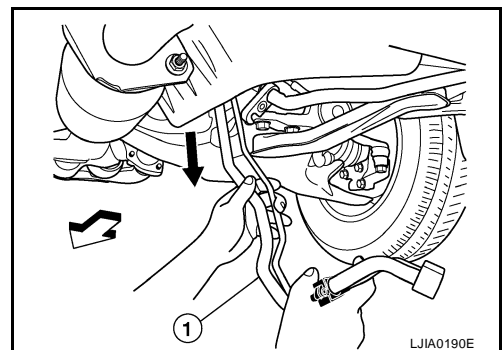

INSTALLATION

CAUTION:

- Clean all of the A/C pipe fittings and connections.
- Replace the O-rings of the high/low-pressure pipe with new ones.
- Lubricate all the O-rings with NISSAN A/C System Lubricant Type S (DH-PS), part number KLH00-PAGS1P.

NOTE:

The service replacement high/low pressure pipe is a two piece pipe assembly.

1. Install and position the new lower high/low pressure pipe without tightening the connections.

REFRIGERANT LINES

NOTE:

To ease installation, first remove the A/C support clip from the lower section high/low pressure pipe and secure it to the dash panel threaded stud.

2. Install the new upper high/low pressure pipe through the engine compartment.

a. Install the high/low pressure pipe to the front expansion valve and only hand tighten the connector bolt (1) as shown.

- Air cleaner to electric throttle control actuator tube (2)
- Electric throttle control actuator (3)
- ←: Front

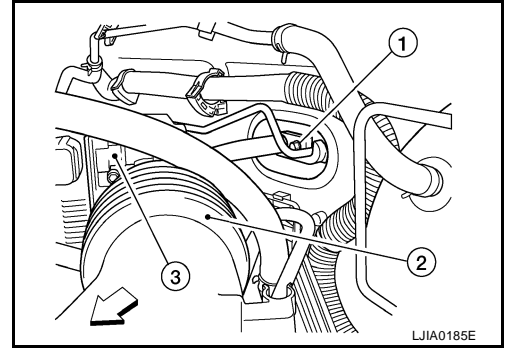

b. Hand tighten the fittings between the upper and lower high pressure pipe (A) and the low pressure pipe (B) as shown.

- ←: Front

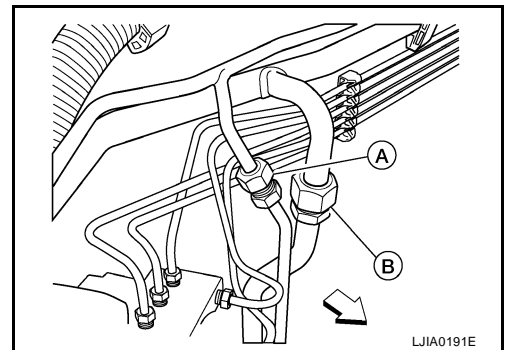

c. Hand tighten the high pressure pipe connection (1) and low pressure pipe connection (2) located near the RH front suspension strut tower (3) as shown.

d. Install the A/C pipe clamp bolt (A) to the RH front suspension strut tower (3) as shown.

e. Attach the high/low pressure pipe to the A/C support clip (secured to the dash panel threaded stud).

f. Tighten the high pressure pipe connection (1) and low pressure pipe connection (2) located near the RH front suspension strut tower (3) as shown to specification.

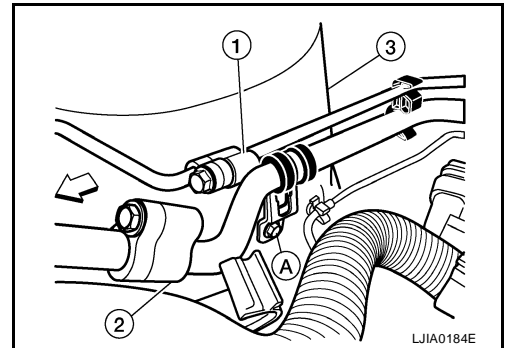

3. Complete the installation of the lower high/low pressure pipe.

CAUTION:

- Clean all of the A/C pipe fittings and connections.
- Replace the O-rings of the high/low-pressure pipe with new ones.
- Lubricate all the O-rings with NISSAN A/C System Oil Type S (DH-PS), part number KLH00-PAGS1P.

a. Under the vehicle, tighten the high/low pressure pipe connection (1) bolt (A) as shown to specification.

b. Install the A/C pipe clamp (2) and tighten the A/C pipe clamp bolt (B).

c. As necessary, reposition the rear heater pipe clamp (3).

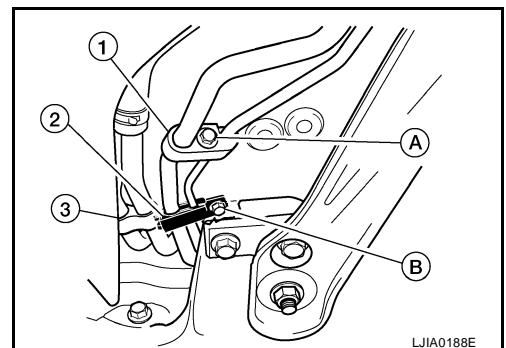

REFRIGERANT LINES

- d. Attach the other pipe support clip to the dash panel threaded stud.
- e. From the engine compartment, tighten the fittings between the upper and lower high pressure pipe (A) and the low pressure pipe (B) as shown to specification.

- ←: Front

CAUTION:

- Do NOT damage the hydraulic brake lines or any other surrounding parts when tightening the fittings.

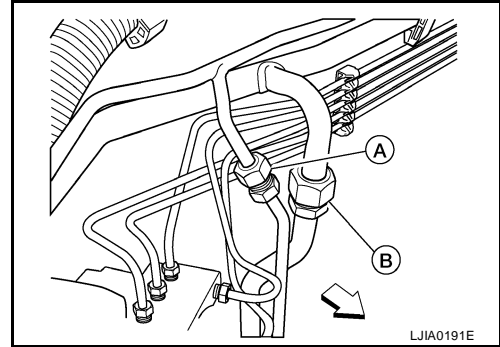

4. Connect the power brake booster vacuum hose to the intake manifold collector.
5. Check that there is sufficient clearance between the lower high/low pressure pipe and the front stabilizer bar. Adjust the lower high/low pressure pipe as necessary.
6. Evacuate and recharge the A/C system and check the A/C system for leaks. Refer to [ATC-193, "HFC-134a \(R-134a\) Service Procedure"](#).
7. Install the remaining components in the reverse order of removal.

Removal and Installation for Refrigerant Pressure Sensor

EJS004LD

REMOVAL

1. Discharge the refrigerant. Refer to [ATC-193, "HFC-134a \(R-134a\) Service Procedure"](#).
2. Disconnect the refrigerant pressure sensor connector and remove the refrigerant pressure sensor from the condenser.

CAUTION:

Be careful not to damage the condenser fins.

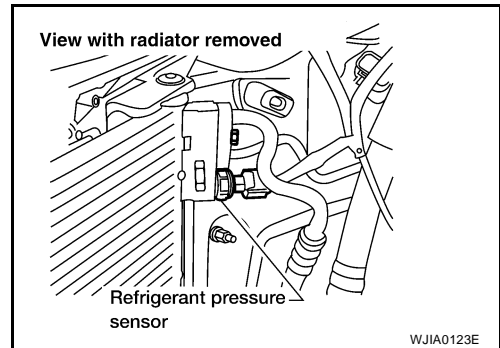

INSTALLATION

Installation is in the reverse order of removal.
Refer to [ATC-195, "Components"](#).

CAUTION:

- Be careful not to damage the condenser fins.
- Replace the O-ring of the refrigerant pressure sensor with a new one, then apply compressor oil to it when installing it.
- After charging refrigerant, check for leaks.

Removal and Installation for Condenser

EJS004LE

REMOVAL

1. Discharge the refrigerant. Refer to [ATC-193, "HFC-134a \(R-134a\) Service Procedure"](#).
2. Remove the radiator. Refer to [CO-15, "RADIATOR"](#).

CAUTION:

Be careful not to damage the core surface of the condenser and the radiator.

REFRIGERANT LINES

3. Disconnect the high-pressure flexible hose and the high-pressure pipe from the condenser.

CAUTION:

Cap or wrap the joint of the pipe with suitable material such as vinyl tape to avoid the entry of air.

4. Disconnect the refrigerant pressure sensor connector.
5. Remove the refrigerant pressure sensor.

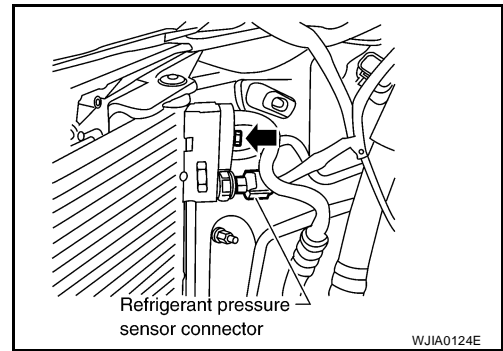

6. Carefully release retaining clips located on top driver side of condenser and rotate the condenser out of its mounts as shown.

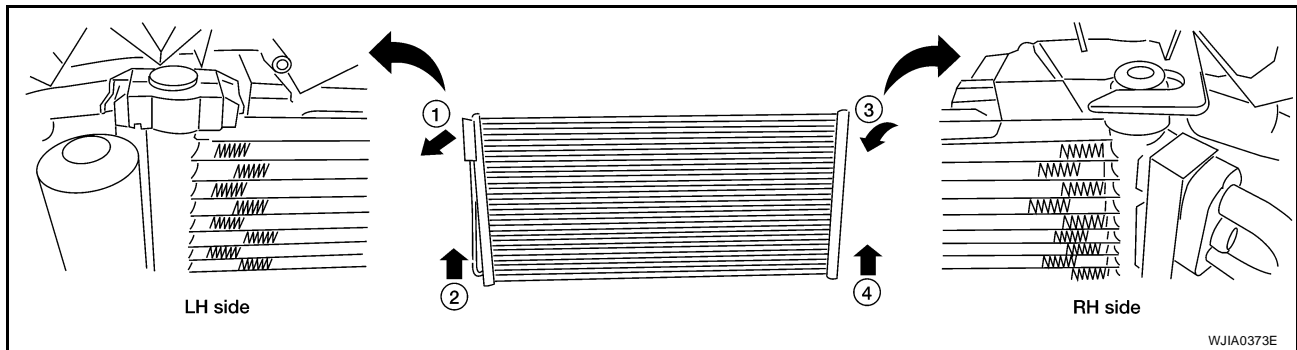

INSTALLATION

Installation is in the reverse order of removal.

Refer to [ATC-195, "Components"](#).

CAUTION:

- Replace the O-rings of the high-pressure pipe, refrigerant pressure sensor, and high-pressure flexible hose with new ones, then apply compressor oil to them when installing them.
- After charging refrigerant, check for leaks.

A
B
C
D
E
F
G
H
I

ATC

K
L
M

REFRIGERANT LINES

Removal and Installation for Front Evaporator

EJS004LF

Front Heater and Cooling Unit Assembly

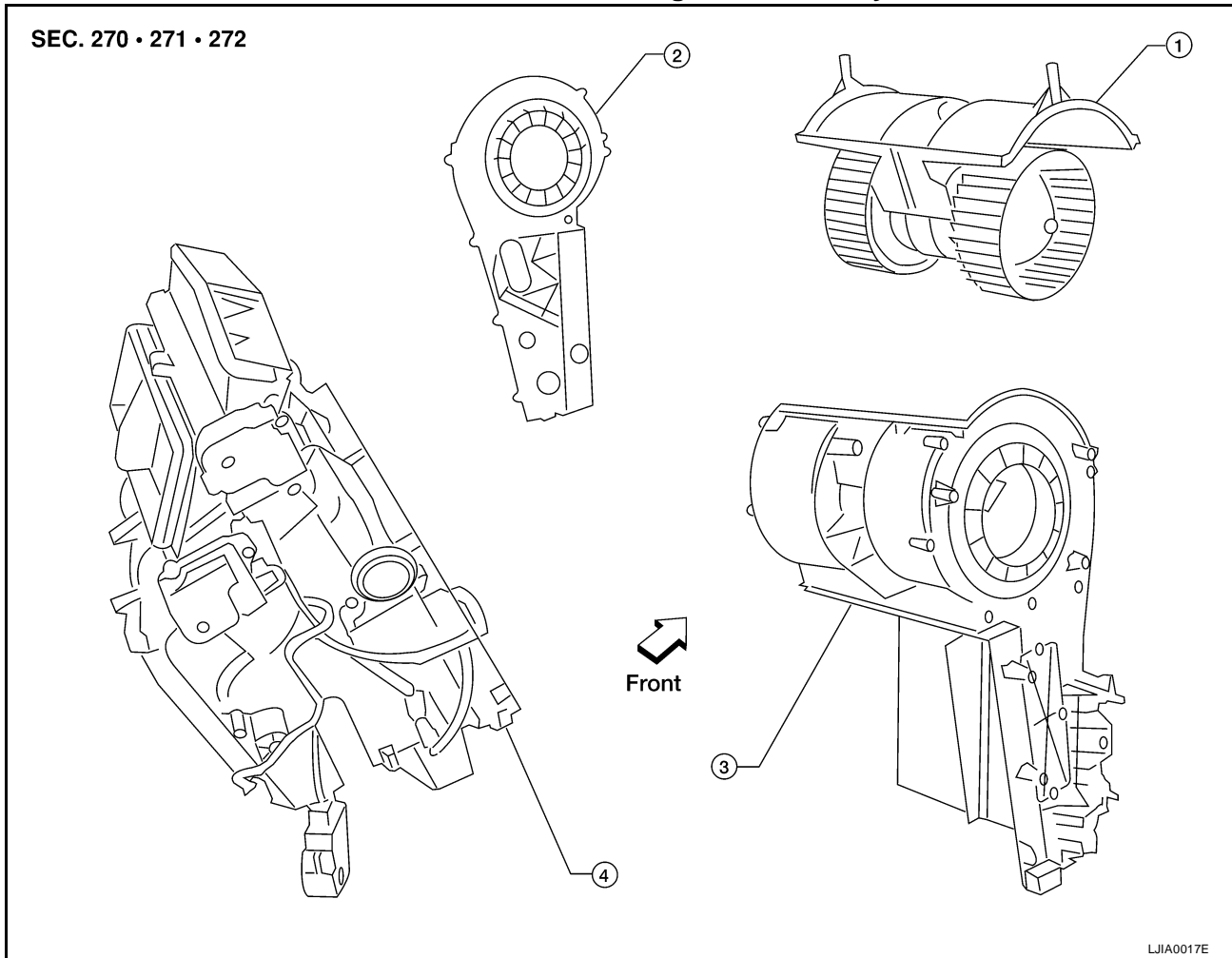

REMOVAL

1. Remove the front heater and cooling unit assembly. Refer to [ATC-170, "FRONT HEATER AND COOLING UNIT ASSEMBLY"](#).
2. Remove the blower motor side cover.
3. Remove the front blower motor.
4. Remove the heater core and evaporator case bottom cover.

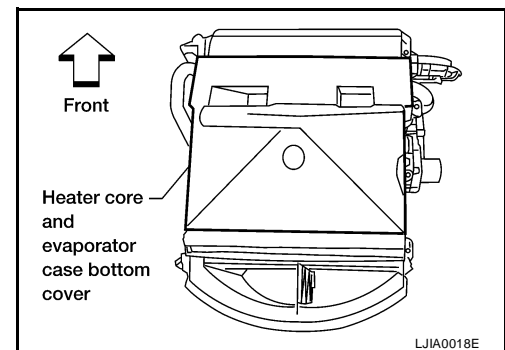

5. Remove the blower motor case.

REFRIGERANT LINES

6. Remove the two in-cabin microfilters.
7. Remove the evaporator.

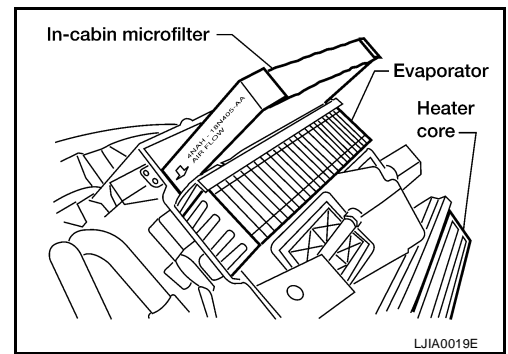

INSTALLATION

Installation is in the reverse order of removal.

CAUTION:

- Replace the O-rings on the low-pressure flexible hose and the high-pressure pipe with new ones. Apply compressor oil to the O-rings before installing them.
- When installing the in-cabin microfilters, face the microfilters according to the air flow direction arrow printed on the side of the filters.

A
B
C
D
E
F
G
H
I

ATC

K
L
M

REFRIGERANT LINES

Removal and Installation for Rear Evaporator

EJS004LG

Rear Heater and Cooling Unit Assembly

SEC. 274

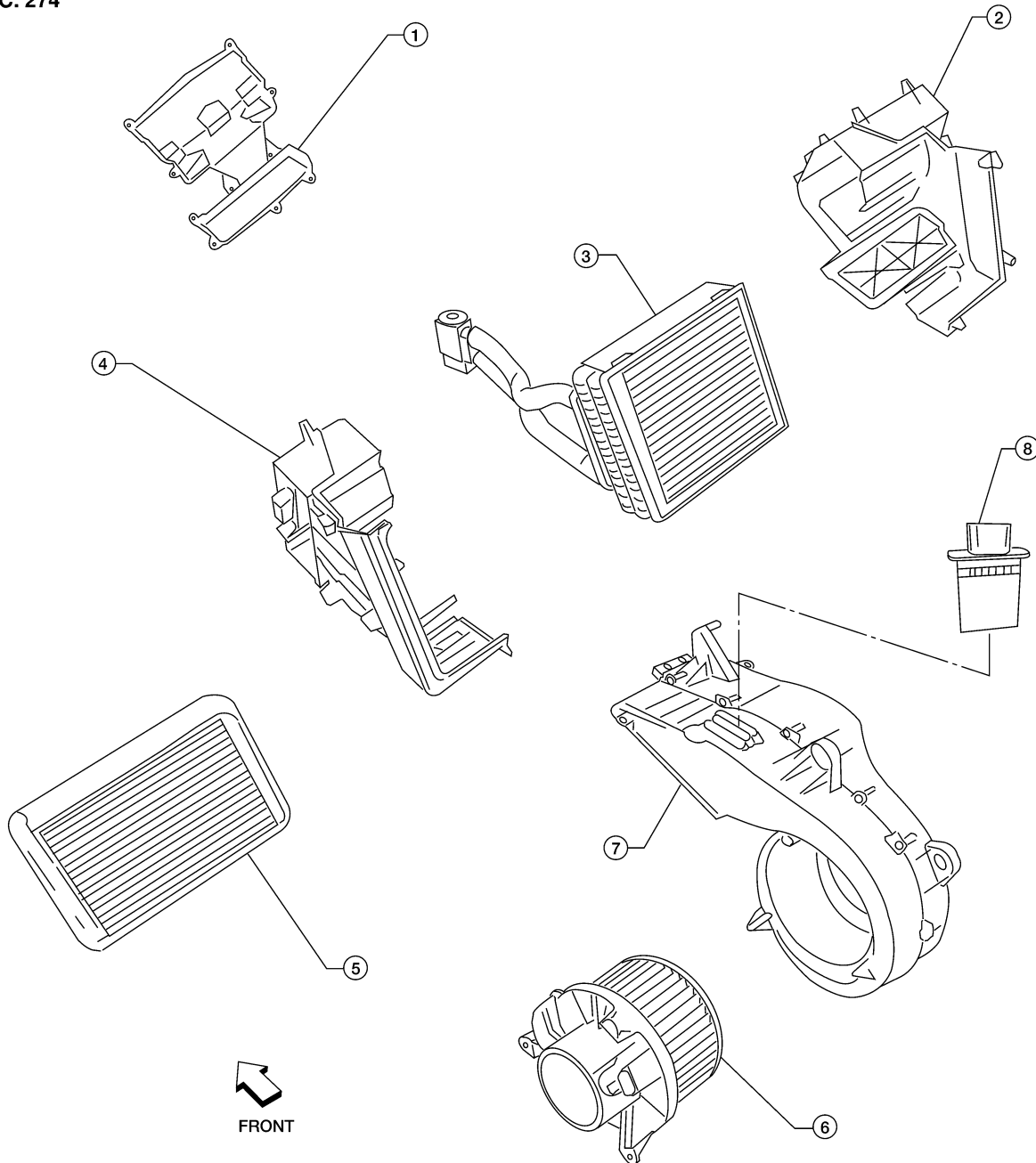

- | | | |
|----------------------|------------------------------------|----------------------|
| 1. Front cover | 2. Evaporator and heater core case | 3. Evaporator |
| 4. Side cover | 5. Heater core | 6. Rear blower motor |
| 7. Blower motor case | 8. Variable blower control (rear) | |

LJIA0020E

REMOVAL

1. Remove the rear heater and cooling unit assembly from the vehicle. Refer to [ATC-171, "REAR HEATER AND COOLING UNIT ASSEMBLY"](#).
2. Remove the rear blower motor.
3. Remove the variable blower control (rear).

REFRIGERANT LINES

4. Remove the rear air mix door motor.
5. Remove the rear duct and blend door assembly. Refer to [ATC-190, "DEFROSTER NOZZLE"](#) .
6. Disassemble the rear heater and cooling unit assembly to remove the evaporator.

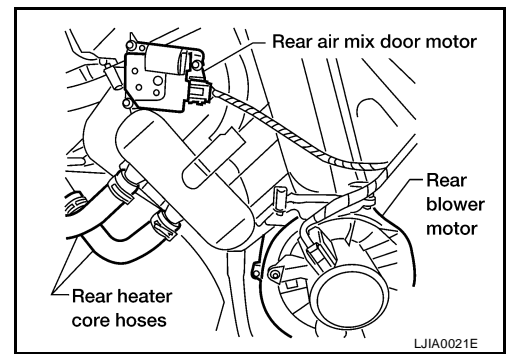

INSTALLATION

Installation is in the reverse order of removal.

CAUTION:

- Replace the O-rings on the rear A/C pipes with new ones, then apply compressor oil to them when installing them.
- After charging refrigerant, check for leaks

Removal and Installation for Front Expansion Valve

EJS004LH

REMOVAL

1. Discharge the refrigerant. Refer to [ATC-193, "HFC-134a \(R-134a\) Service Procedure"](#) .
2. Remove the front heater and cooling unit assembly. Refer to [ATC-170, "FRONT HEATER AND COOLING UNIT ASSEMBLY"](#) .
3. Remove the cooler grommet.
4. Remove the expansion valve.

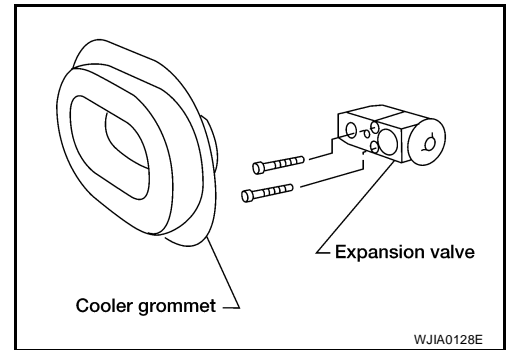

INSTALLATION

Installation is in the reverse order of removal.

Expansion valve bolts

: 4 N·m (0.4 kg·m, 35 in·lb)

A/C refrigerant pipe to expansion valve bolt

: Refer to [ATC-195, "Components"](#) .

CAUTION:

- Replace the O-rings on the A/C refrigerant pipes with new ones, then apply compressor oil to them when installing them.
- After charging refrigerant, check for leaks

Removal and Installation for Rear Expansion Valve

EJS004LI

REMOVAL

1. Discharge the refrigerant. Refer to [ATC-193, "HFC-134a \(R-134a\) Service Procedure"](#) .
2. Remove the rear RH interior side trim panel. Refer to [EI-35, "RIGHT SIDE AND REAR"](#) .
3. Disconnect the A/C refrigerant pipes from the expansion valve.

CAUTION:

Cap or wrap the A/C refrigerant pipe ends with a suitable material such as vinyl tape to avoid the entry of air and contaminants.

4. Remove the expansion valve.

INSTALLATION

Installation is in the reverse order of removal.

A
B
C
D
E
F
G
H
I
J
K
L
M

ATC

REFRIGERANT LINES

- Expansion valve bolts : 4 N-m (0.4 kg-m, 35 in-lb)
A/C refrigerant pipe to expansion valve bolt : Refer to [ATC-195, "Components"](#) .

CAUTION:

- Replace the O-rings on the A/C refrigerant pipes with new ones, then apply compressor oil to them when installing them.
- After charging refrigerant, check for leaks

Checking for Refrigerant Leaks

EJS004LJ

Perform a visual inspection of all refrigeration parts, fittings, hoses and components for signs of A/C oil leakage, damage, and corrosion. Any A/C oil leakage may indicate an area of refrigerant leakage. Allow extra inspection time in these areas when using either an electronic refrigerant leak detector (J-41995) or fluorescent dye leak detector (J-42220).

If any dye is observed using a fluorescent dye leak detector (J-42220), confirm the leak using a electronic refrigerant leak detector (J-41995). It is possible that the dye is from a prior leak that was repaired and not properly cleaned.

When searching for leaks, do not stop when one leak is found but continue to check for additional leaks at all system components and connections.

When searching for refrigerant leaks using an electronic refrigerant leak detector (J-41995), move the probe along the suspected leak area at 25 - 50 mm (1 - 2 in) per second and no further than 6 mm (1/4 in) from the component.

CAUTION:

Moving the electronic refrigerant leak detector probe slower and closer to the suspected leak area will improve the chances of finding a leak.

Checking System for Leaks Using the Fluorescent Dye Leak Detector

EJS004LK

1. Check the A/C system for leaks using the fluorescent dye leak detector and safety goggles (J-42220) in a low sunlight area (area without windows preferable). Illuminate all components, fittings and lines. The dye will appear as a bright green/yellow area at the point of leakage. Fluorescent dye observed at the evaporator drain opening indicates an evaporator core assembly leak (tubes, core or expansion valve).
2. If the suspected area is difficult to see, use an adjustable mirror or wipe the area with a clean shop rag or cloth, then inspect the shop rag or cloth with the fluorescent dye leak detector (J-42220) for dye residue.
3. After the leak is repaired, remove any residual dye using refrigerant dye cleaner (J-43872) to prevent future misdiagnosis.
4. Perform a system performance check and then verify the leak repair using a electronic refrigerant leak detector (J-41995).

NOTE:

- Other gases in the work area or substances on the A/C components, for example, anti-freeze, windshield washer fluid, solvents and oils, may falsely trigger the leak detector. Make sure the surfaces to be checked are clean.
- Clean with a dry cloth or blow off with shop air.
- Do not allow the sensor tip of the electronic refrigerant leak detector (J-41995) to contact with any substance. This can also cause false readings and may damage the detector.

Dye Injection

EJS004LL

NOTE:

This procedure is only necessary when recharging the system or when the compressor has seized and must be replaced.

1. Check the A/C system static (at rest) pressure. Pressure must be at least 345 kPa (3.52 kg/cm² , 50 psi).
2. Pour one bottle 7.4 cc (1/4 ounce) of the HFC-134a (R-134a) fluorescent leak detection dye (J-41447) into the HFC-134a (R-134a) dye injector (J-41459).

CAUTION:

If repairing the A/C system or replacing a component, pour the HFC-134a (R-134a) fluorescent leak detection dye (J-41447) directly into the open system connection and proceed with the service procedures.

3. Connect the injector tool (J-41459) to the low-pressure service valve.
4. Start the engine and switch the A/C system ON.

REFRIGERANT LINES

- When the A/C system is operating (compressor running), inject one bottle 7.4 cc (1/4 ounce) of HFC-134a (R-134a) fluorescent leak detection dye (J-41447) through the low-pressure service valve using HFC-134a (R-134a) dye injector (J-41459). Refer to the manufacturer's operating instructions.
- With the engine still running, disconnect the HFC-134a (R-134a) dye injector (J-41459) from the low-pressure service valve.
- Operate the A/C system for a minimum of 20 minutes to mix the HFC-134a (R-134a) fluorescent leak detection dye (J-41447) with the A/C system oil. Depending on the leak size, operating conditions and location of the leak, it may take from minutes to days for the HFC-134a (R-134a) fluorescent leak detection dye to penetrate an A/C system leak and become visible.

Electronic Refrigerant Leak Detector PRECAUTIONS FOR HANDLING LEAK DETECTOR

EJS004LM

NOTE:

When performing a refrigerant leak check, use a electronic refrigerant leak detector (J-41995) or equivalent. Ensure that the electronic refrigerant leak detector (J-41995) is calibrated and set properly according to the manufacturer's operating instructions.

The electronic refrigerant leak detector (J-41995) is a delicate device. To use the electronic refrigerant leak detector (J-41995) properly, read the manufacturer's operating instructions and perform any specified maintenance.

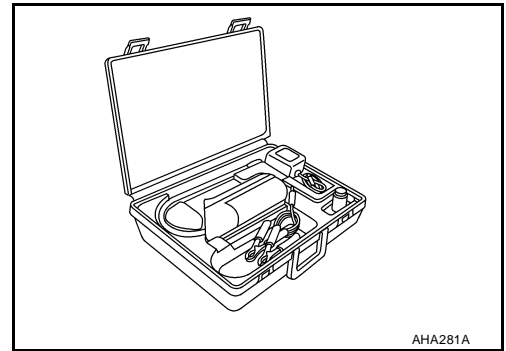

- Position the probe approximately 5 mm (3/16 in) away from the point to be checked as shown.

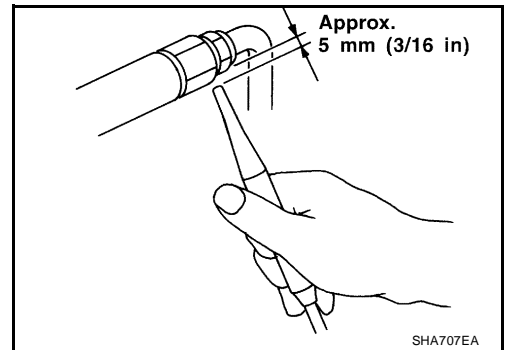

- When checking for leaks, circle each fitting completely with the probe as shown.

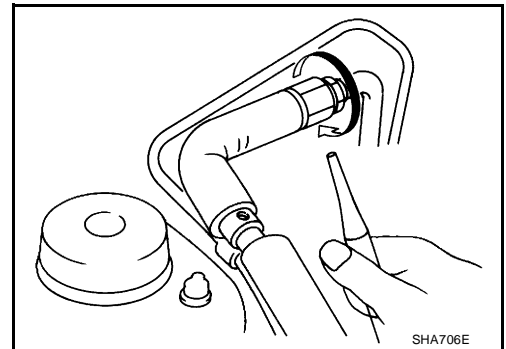

A
B
C
D
E
F
G
H
I
ATC
K
L
M

REFRIGERANT LINES

3. Move the probe along each component at a speed of approximately 25 - 50 mm (1 - 2 in)/second as shown.

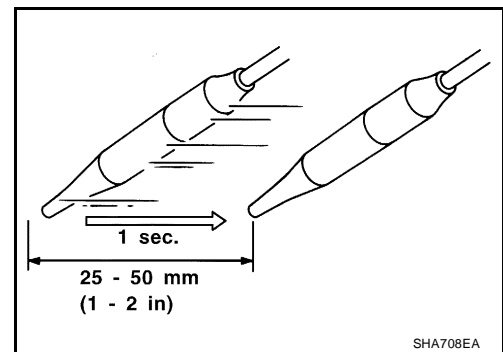

CHECKING PROCEDURE

NOTE:

To prevent inaccurate or false readings, make sure there is no refrigerant vapor, shop chemicals, or cigarette smoke in the vicinity of the vehicle. Perform the leak test in a calm area (low air/wind movement) so that the leaking refrigerant is not dispersed.

1. Turn the engine OFF.
2. Connect the manifold gauge set (J-39183-C) to the A/C service ports. Refer to [ATC-193, "SETTING OF SERVICE TOOLS AND EQUIPMENT"](#).
3. Check if the A/C refrigerant pressure is at least 345 kPa (3.52 kg/cm², 50 psi) above a temperature of 16°C (61°F). If less than specification, recover/evacuate and recharge the system with the specified amount of refrigerant. Refer to [ATC-193, "HFC-134a \(R-134a\) Service Procedure"](#).

NOTE:

At temperatures below 16°C (61°F), leaks may not be detected since the system may not reach 345 kPa (3.52 kg/cm², 50 psi) pressure.

4. Conduct the leak test from the high pressure side (compressor discharge to evaporator inlet) to the low pressure side (evaporator drain hose to shaft seal). Refer to [ATC-195, "Components"](#). Clean the component to be checked and carefully move the electronic refrigerant leak detector probe completely around the following connections and components.
 - Compressor
 - High and low-pressure pipe and hose fittings, relief valve, and compressor shaft seal
 - Liquid tank
 - Refrigerant pressure sensor
 - Service valves. Check all around the service valves. Ensure service valve caps are secured on the service valves (to prevent leaks).

NOTE:

After removing manifold gauge set (J-39183-C) from the service valves, wipe any residue from the service valves to prevent any false readings by the electronic refrigerant leak detector (J-41995).

- Evaporator

With engine OFF, turn blower fan on "High" for at least 15 seconds to dissipate any refrigerant trace in the heater and cooling unit assembly. Wait a minimum of 10 minutes accumulation time (refer to the manufacturer's recommended procedure for actual wait time) before inserting the electronic refrigerant leak detector probe into the heater and cooling unit assembly drain hose.

NOTE:

Keep the probe inserted for at least 10 seconds. Use caution not to contaminate the probe tip with water or dirt that may be in the drain hose.

5. If a leak is detected, verify at least once by blowing compressed air into the area of the suspected leak, then repeat the leak check.
6. Do not stop when one leak is found. Continue to check for additional leaks at all system components and connections.
7. If no leaks are found, perform steps 8 - 11.
8. Start the engine.
9. Set the heater A/C controls as follows:

REFRIGERANT LINES

NOTE:

For the automatic system, turn OFF the automatic controls and set the heater A/C controls manually.

- a. A/C switch: ON
 - b. Air flow: VENT mode
 - c. Intake position: RECIRCULATION mode
 - d. Temperature: MAX cold
 - e. Blower fan speed: HIGH
10. Run the engine at 1,500 rpm for at least 2 minutes.
 11. Turn the engine OFF and perform the leak check again following steps 4 through 6 above.

Refrigerant leaks should be checked immediately after turning the engine OFF. Begin with the leak detector at the compressor. The pressure on the high pressure side will gradually drop after the refrigerant circulation stops and pressure on the low pressure side will gradually rise, as shown in the graph. Some leaks are more easily detected when the pressure is high.

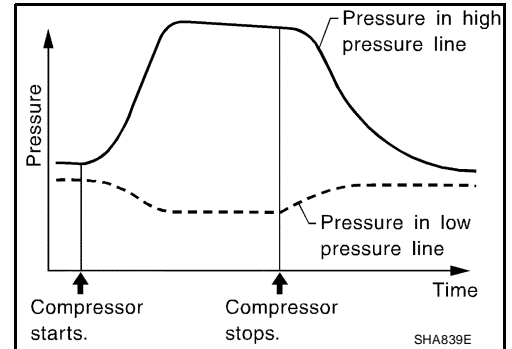

12. Before connecting the recovery/recycling equipment to the vehicle, check the recovery/recycling equipment gauges. No refrigerant pressure should be displayed. If pressure is displayed, recover the refrigerant from the equipment lines and then check the refrigerant purity.
13. Confirm refrigerant purity in supply tank using recovery/recycling equipment and refrigerant identifier equipment (J-41810-NI).
14. Confirm the refrigerant purity in the vehicle's A/C system using recovery/recycling equipment and refrigerant identifier equipment (J-41810-NI).
15. Discharge the A/C system using recovery/recycling equipment. Repair the leaking fitting or component as necessary.
16. Evacuate and recharge the A/C system and perform the leak test to confirm that there are no refrigerant leaks.
17. Conduct the Operational Check to ensure system works properly. Refer to [ATC-55, "Operational Check \(Front\)"](#).

A
B
C
D
E
F
G
H
I
K
L
M

ATC

SERVICE DATA AND SPECIFICATIONS (SDS)

SERVICE DATA AND SPECIFICATIONS (SDS)

PFP:00030

Service Data and Specifications (SDS) COMPRESSOR

EJS004LN

Make	ZEXEL VALEO CLIMATE CONTROL
Model	DKS-17D
Type	Swash plate
Displacement	175.5 cm ³ (10.7 in ³) / revolution
Cylinder bore x stroke	30.5 x 24.0 mm (1.20 x 0.94 in)
Direction of rotation	Clockwise (viewed from drive end)
Drive belt	Poly V

OIL

Name	NISSAN A/C System Oil Type S	
Capacity	Total in system	220 mℓ (7.44 US fl oz, 7.7 Imp fl oz)
	Compressor (service part) charging amount	Refer to ATC-22, "CHECKING AND ADJUSTING" .

REFRIGERANT

Type	HFC-134a (R-134a)
Capacity	900 ± 50 g (1.98 ± 0.11 lb)

ENGINE IDLING SPEED

Refer to [EC-78, "Idle Speed and Ignition Timing Check"](#) .

BELT TENSION

Refer to [MA-12, "Tension Adjustment"](#) .