

A
EC
C

SECTION EC

ENGINE CONTROL SYSTEM

CONTENTS

<p>INDEX FOR DTC 8</p> <p style="padding-left: 20px;">DTC No. Index 8</p> <p style="padding-left: 20px;">Alphabetical Index 12</p> <p>PRECAUTIONS 16</p> <p style="padding-left: 20px;">Precautions for Supplemental Restraint System (SRS) "AIR BAG" and "SEAT BELT PRE-TENSIONER" 16</p> <p style="padding-left: 20px;">On Board Diagnostic (OBD) System of Engine and A/T 16</p> <p style="padding-left: 20px;">Precaution 16</p> <p>PREPARATION 20</p> <p style="padding-left: 20px;">Special Service Tools 20</p> <p style="padding-left: 20px;">Commercial Service Tools 22</p> <p>ENGINE CONTROL SYSTEM 23</p> <p style="padding-left: 20px;">System Diagram 23</p> <p style="padding-left: 20px;">Multiport Fuel Injection (MFI) System 24</p> <p style="padding-left: 20px;">Electronic Ignition (EI) System 26</p> <p style="padding-left: 20px;">Fuel Cut Control (at No Load and High Engine Speed) 27</p> <p>AIR CONDITIONING CUT CONTROL 28</p> <p style="padding-left: 20px;">Input/Output Signal Chart 28</p> <p style="padding-left: 20px;">System Description 28</p> <p>AUTOMATIC SPEED CONTROL DEVICE (ASCD).. 29</p> <p style="padding-left: 20px;">System Description 29</p> <p style="padding-left: 20px;">Component Description 30</p> <p>CAN COMMUNICATION 31</p> <p style="padding-left: 20px;">System Description 31</p> <p>EVAPORATIVE EMISSION SYSTEM 32</p> <p style="padding-left: 20px;">Description 32</p> <p style="padding-left: 20px;">Component Inspection 35</p> <p style="padding-left: 20px;">Removal and Installation 36</p> <p style="padding-left: 20px;">How to Detect Fuel Vapor Leakage 36</p> <p>ON BOARD REFUELING VAPOR RECOVERY (ORVR) 39</p> <p style="padding-left: 20px;">System Description 39</p> <p style="padding-left: 20px;">Diagnostic Procedure 40</p> <p style="padding-left: 20px;">Component Inspection 43</p> <p>POSITIVE CRANKCASE VENTILATION 45</p> <p style="padding-left: 20px;">Description 45</p> <p style="padding-left: 20px;">Component Inspection 45</p>	<p style="text-align: right;">NVIS (NISSAN VEHICLE IMMOBILIZER SYSTEM-NATS) 47</p> <p style="padding-left: 20px; text-align: right;">Description 47</p> <p>ON BOARD DIAGNOSTIC (OBD) SYSTEM 48</p> <p style="padding-left: 20px; text-align: right;">Introduction 48</p> <p style="padding-left: 20px; text-align: right;">Two Trip Detection Logic 48</p> <p style="padding-left: 20px; text-align: right;">Emission-related Diagnostic Information 49</p> <p style="padding-left: 20px; text-align: right;">Malfunction Indicator Lamp (MIL) 64</p> <p style="padding-left: 20px; text-align: right;">OBD System Operation Chart 68</p> <p>BASIC SERVICE PROCEDURE 73</p> <p style="padding-left: 20px; text-align: right;">Basic Inspection 73</p> <p style="padding-left: 20px; text-align: right;">Idle Speed and Ignition Timing Check 78</p> <p style="padding-left: 20px; text-align: right;">Procedure After Replacing ECM 79</p> <p style="padding-left: 20px; text-align: right;">VIN Registration 79</p> <p style="padding-left: 20px; text-align: right;">Accelerator Pedal Released Position Learning 80</p> <p style="padding-left: 20px; text-align: right;">Throttle Valve Closed Position Learning 80</p> <p style="padding-left: 20px; text-align: right;">Idle Air Volume Learning 80</p> <p style="padding-left: 20px; text-align: right;">Fuel Pressure Check 82</p> <p>TROUBLE DIAGNOSIS 86</p> <p style="padding-left: 20px; text-align: right;">Trouble Diagnosis Introduction 86</p> <p style="padding-left: 20px; text-align: right;">DTC Inspection Priority Chart 92</p> <p style="padding-left: 20px; text-align: right;">Fail-Safe Chart 94</p> <p style="padding-left: 20px; text-align: right;">Symptom Matrix Chart 95</p> <p style="padding-left: 20px; text-align: right;">Engine Control Component Parts Location 99</p> <p style="padding-left: 20px; text-align: right;">Vacuum Hose Drawing 106</p> <p style="padding-left: 20px; text-align: right;">Circuit Diagram 107</p> <p style="padding-left: 20px; text-align: right;">ECM Harness Connector Terminal Layout 109</p> <p style="padding-left: 20px; text-align: right;">ECM Terminals and Reference Value 109</p> <p style="padding-left: 20px; text-align: right;">CONSULT-II Function (ENGINE) 119</p> <p style="padding-left: 20px; text-align: right;">Generic Scan Tool (GST) Function 131</p> <p style="padding-left: 20px; text-align: right;">CONSULT-II Reference Value in Data Monitor 134</p> <p style="padding-left: 20px; text-align: right;">Major Sensor Reference Graph in Data Monitor Mode 137</p> <p>TROUBLE DIAGNOSIS - SPECIFICATION VALUE 139</p> <p style="padding-left: 20px; text-align: right;">Description 139</p> <p style="padding-left: 20px; text-align: right;">Testing Condition 139</p> <p style="padding-left: 20px; text-align: right;">Inspection Procedure 139</p> <p style="padding-left: 20px; text-align: right;">Diagnostic Procedure 140</p> <p>TROUBLE DIAGNOSIS FOR INTERMITTENT INCIDENT 149</p>
---	---

Description	149	Component Description	192
Diagnostic Procedure	149	CONSULT-II Reference Value in Data Monitor Mode	192
POWER SUPPLY AND GROUND CIRCUIT	150	On Board Diagnosis Logic	192
Wiring Diagram	150	DTC Confirmation Procedure	193
Diagnostic Procedure	153	Overall Function Check	194
Ground Inspection	158	Wiring Diagram	195
DTC U1000, U1001 CAN COMMUNICATION LINE	159	Diagnostic Procedure	196
Description	159	Component Inspection	200
On Board Diagnosis Logic	159	Removal and Installation	201
DTC Confirmation Procedure	159	DTC P0102, P0103 MAF SENSOR	202
Wiring Diagram	160	Component Description	202
Diagnostic Procedure	161	CONSULT-II Reference Value in Data Monitor Mode	202
DTC U1010 CAN COMMUNICATION	162	On Board Diagnosis Logic	202
Description	162	DTC Confirmation Procedure	203
On Board Diagnosis Logic	162	Wiring Diagram	204
DTC Confirmation Procedure	162	Diagnostic Procedure	205
Diagnostic Procedure	163	Component Inspection	209
DTC P0011, P0021 IVT CONTROL	164	Removal and Installation	210
Description	164	DTC P0112, P0113 IAT SENSOR	211
CONSULT-II Reference Value in Data Monitor Mode	164	Component Description	211
On Board Diagnosis Logic	165	On Board Diagnosis Logic	211
DTC Confirmation Procedure	165	DTC Confirmation Procedure	211
Diagnostic Procedure	166	Wiring Diagram	212
Component Inspection	167	Diagnostic Procedure	213
Removal and Installation	167	Component Inspection	215
DTC P0031, P0032, P0051, P0052 A/F SENSOR 1 HEATER	168	Removal and Installation	215
Description	168	DTC P0117, P0118 ECT SENSOR	216
CONSULT-II Reference Value in Data Monitor Mode	168	Component Description	216
On Board Diagnosis Logic	168	On Board Diagnosis Logic	216
DTC Confirmation Procedure	168	DTC Confirmation Procedure	217
Wiring Diagram	169	Wiring Diagram	218
Diagnostic Procedure	173	Diagnostic Procedure	219
Component Inspection	175	Component Inspection	221
Removal and Installation	175	Removal and Installation	221
DTC P0037, P0038, P0057, P0058 HO2S2 HEATER	176	DTC P0122, P0123 TP SENSOR	222
Description	176	Component Description	222
CONSULT-II Reference Value in Data Monitor Mode	176	CONSULT-II Reference Value in Data Monitor Mode	222
On Board Diagnosis Logic	176	On Board Diagnosis Logic	222
DTC Confirmation Procedure	177	DTC Confirmation Procedure	223
Wiring Diagram	178	Wiring Diagram	224
Diagnostic Procedure	182	Diagnostic Procedure	226
Component Inspection	184	Component Inspection	229
Removal and Installation	184	Removal and Installation	229
DTC P0075, P0081 IVT CONTROL SOLENOID VALVE	185	DTC P0125 ECT SENSOR	230
Component Description	185	Component Description	230
CONSULT-II Reference Value in Data Monitor Mode	185	On Board Diagnosis Logic	230
On Board Diagnosis Logic	185	DTC Confirmation Procedure	231
DTC Confirmation Procedure	185	Diagnostic Procedure	232
Wiring Diagram	186	Component Inspection	233
Diagnostic Procedure	190	Removal and Installation	233
Component Inspection	191	DTC P0127 IAT SENSOR	234
Removal and Installation	191	Component Description	234
DTC P0101 MAF SENSOR	192	On Board Diagnosis Logic	234
		DTC Confirmation Procedure	234
		Diagnostic Procedure	235

Component Inspection	236	On Board Diagnosis Logic	295	
Removal and Installation	236	DTC Confirmation Procedure	296	A
DTC P0128 THERMOSTAT FUNCTION	237	Overall Function Check	297	
On Board Diagnosis Logic	237	Wiring Diagram	299	EC
DTC Confirmation Procedure	237	Diagnostic Procedure	303	
Diagnostic Procedure	237	Component Inspection	307	
Component Inspection	238	Removal and Installation	309	C
Removal and Installation	238	DTC P0139, P0159 HO2S2	310	
DTC P0130, P0150 A/F SENSOR 1	239	Component Description	310	D
Component Description	239	CONSULT-II Reference Value in Data Monitor Mode	310	
CONSULT-II Reference Value in Data Monitor Mode	239	On Board Diagnosis Logic	310	
On Board Diagnosis Logic	239	DTC Confirmation Procedure	311	E
DTC Confirmation Procedure	239	Overall Function Check	311	
Overall Function Check	241	Wiring Diagram	313	F
Wiring Diagram	242	Diagnostic Procedure	317	
Diagnostic Procedure	246	Component Inspection	319	
Removal and Installation	249	Removal and Installation	321	
DTC P0131, P0151 A/F SENSOR 1	250	DTC P0171, P0174 FUEL INJECTION SYSTEM FUNCTION	322	G
Component Description	250	On Board Diagnosis Logic	322	
CONSULT-II Reference Value in Data Monitor Mode	250	DTC Confirmation Procedure	322	
On Board Diagnosis Logic	250	Wiring Diagram	324	H
DTC Confirmation Procedure	250	Diagnostic Procedure	328	
Wiring Diagram	252	DTC P0172, P0175 FUEL INJECTION SYSTEM FUNCTION	334	
Diagnostic Procedure	256	On Board Diagnosis Logic	334	I
Removal and Installation	259	DTC Confirmation Procedure	334	
DTC P0132, P0152 A/F SENSOR 1	260	Wiring Diagram	336	J
Component Description	260	Diagnostic Procedure	340	
CONSULT-II Reference Value in Data Monitor Mode	260	DTC P0181 FTT SENSOR	346	
On Board Diagnosis Logic	260	Component Description	346	K
DTC Confirmation Procedure	260	On Board Diagnosis Logic	346	
Wiring Diagram	262	DTC Confirmation Procedure	346	
Diagnostic Procedure	266	Wiring Diagram	348	L
Removal and Installation	269	Diagnostic Procedure	349	
DTC P0133, P0153 A/F SENSOR 1	270	Component Inspection	351	
Component Description	270	Removal and Installation	351	
CONSULT-II Reference Value in Data Monitor Mode	270	DTC P0182, P0183 FTT SENSOR	352	M
On Board Diagnosis Logic	270	Component Description	352	
DTC Confirmation Procedure	271	On Board Diagnosis Logic	352	
Wiring Diagram	273	DTC Confirmation Procedure	352	
Diagnostic Procedure	277	Wiring Diagram	353	
Removal and Installation	282	Diagnostic Procedure	354	
DTC P0137, P0157 HO2S2	283	Component Inspection	356	
Component Description	283	Removal and Installation	356	
CONSULT-II Reference Value in Data Monitor Mode	283	DTC P0222, P0223 TP SENSOR	357	
On Board Diagnosis Logic	283	Component Description	357	
DTC Confirmation Procedure	284	CONSULT-II Reference Value in Data Monitor Mode	357	
Overall Function Check	284	On Board Diagnosis Logic	357	
Wiring Diagram	286	DTC Confirmation Procedure	358	
Diagnostic Procedure	290	Wiring Diagram	359	
Component Inspection	292	Diagnostic Procedure	361	
Removal and Installation	294	Component Inspection	364	
DTC P0138, P0158 HO2S2	295	Removal and Installation	364	
Component Description	295	DTC P0300 - P0306 MULTIPLE CYLINDER MIS-FIRE, NO. 1 - 6 CYLINDER MISFIRE	365	
CONSULT-II Reference Value in Data Monitor Mode	295			

On Board Diagnosis Logic	365	Overall Function Check	420
DTC Confirmation Procedure	365	Diagnostic Procedure	421
Diagnostic Procedure	366	DTC P0441 EVAP CONTROL SYSTEM	425
DTC P0327, P0328 KS	374	System Description	425
Component Description	374	On Board Diagnosis Logic	425
On Board Diagnosis Logic	374	DTC Confirmation Procedure	426
DTC Confirmation Procedure	374	Overall Function Check	426
Wiring Diagram	375	Diagnostic Procedure	427
Diagnostic Procedure	376	DTC P0442 EVAP CONTROL SYSTEM	431
Component Inspection	378	On Board Diagnosis Logic	431
Removal and Installation	378	DTC Confirmation Procedure	432
DTC P0335 CKP SENSOR (POS)	379	Diagnostic Procedure	433
Component Description	379	DTC P0443 EVAP CANISTER PURGE VOLUME CONTROL SOLENOID VALVE	439
CONSULT-II Reference Value in Data Monitor Mode	379	Description	439
On Board Diagnosis Logic	379	CONSULT-II Reference Value in Data Monitor Mode	439
DTC Confirmation Procedure	380	On Board Diagnosis Logic	440
Wiring Diagram	381	DTC Confirmation Procedure	440
Diagnostic Procedure	383	Wiring Diagram	441
Component Inspection	386	Diagnostic Procedure	443
Removal and Installation	386	Component Inspection	446
DTC P0340, P0345 CMP SENSOR (PHASE)	387	Removal and Installation	446
Component Description	387	DTC P0444, P0445 EVAP CANISTER PURGE VOLUME CONTROL SOLENOID VALVE	447
On Board Diagnosis Logic	387	Description	447
DTC Confirmation Procedure	387	CONSULT-II Reference Value in Data Monitor Mode	447
Wiring Diagram	389	On Board Diagnosis Logic	448
Diagnostic Procedure	392	DTC Confirmation Procedure	448
Component Inspection	396	Wiring Diagram	449
Removal and Installation	396	Diagnostic Procedure	451
DTC P0400 EGR FUNCTION	397	Component Inspection	452
Description	397	Removal and Installation	453
CONSULT-II Reference Value in Data Monitor Mode	399	DTC P0447 EVAP CANISTER VENT CONTROL VALVE	454
On Board Diagnosis Logic	399	Component Description	454
DTC Confirmation Procedure	399	CONSULT-II Reference Value in Data Monitor Mode	454
Wiring Diagram	401	On Board Diagnosis Logic	454
Diagnostic Procedure	402	DTC Confirmation Procedure	455
DTC P0403 EGR VOLUME CONTROL VALVE	405	Wiring Diagram	456
Description	405	Diagnostic Procedure	457
CONSULT-II Reference Value in Data Monitor Mode	406	Component Inspection	459
On Board Diagnosis Logic	406	DTC P0448 EVAP CANISTER VENT CONTROL VALVE	461
DTC Confirmation Procedure	406	Component Description	461
Wiring Diagram	407	CONSULT-II Reference Value in Data Monitor Mode	461
Diagnostic Procedure	408	On Board Diagnosis Logic	461
Component Inspection	409	DTC Confirmation Procedure	462
Removal and Installation	411	Wiring Diagram	463
DTC P0405, P0406 EGRT SENSOR	412	Diagnostic Procedure	464
Component Description	412	Component Inspection	466
On Board Diagnosis Logic	412	DTC P0451 EVAP CONTROL SYSTEM PRESSURE SENSOR	468
DTC Confirmation Procedure	413	Component Description	468
Wiring Diagram	415	CONSULT-II Reference Value in Data Monitor Mode	468
Diagnostic Procedure	416		
Component Inspection	418		
Removal and Installation	418		
DTC P0420, P0430 THREE WAY CATALYST FUNCTION	419		
On Board Diagnosis Logic	419		
DTC Confirmation Procedure	419		

On Board Diagnosis Logic	468	On Board Diagnosis Logic	512	
DTC Confirmation Procedure	469	DTC Confirmation Procedure	512	A
Diagnostic Procedure	470	Diagnostic Procedure	513	
Component Inspection	471	DTC P0507 ISC SYSTEM	514	EC
DTCP0452 EVAP CONTROL SYSTEM PRESSURE		Description	514	
SENSOR	472	On Board Diagnosis Logic	514	
Component Description	472	DTC Confirmation Procedure	514	
CONSULT-II Reference Value in Data Monitor Mode		Diagnostic Procedure	515	C
	472	DTC P0550 PSP SENSOR	516	
On Board Diagnosis Logic	472	Component Description	516	D
DTC Confirmation Procedure	473	CONSULT-II Reference Value in Data Monitor Mode		
Wiring Diagram	474		516	
Diagnostic Procedure	475	On Board Diagnosis Logic	516	
Component Inspection	478	DTC Confirmation Procedure	516	
DTCP0453 EVAP CONTROL SYSTEM PRESSURE		Wiring Diagram	517	E
SENSOR	479	Diagnostic Procedure	519	
Component Description	479	Component Inspection	521	
CONSULT-II Reference Value in Data Monitor Mode		Removal and Installation	521	F
	479	DTC P0603 ECM POWER SUPPLY	522	
On Board Diagnosis Logic	479	Component Description	522	
DTC Confirmation Procedure	480	On Board Diagnosis Logic	522	G
Wiring Diagram	481	DTC Confirmation Procedure	522	
Diagnostic Procedure	482	Wiring Diagram	523	
Component Inspection	486	Diagnostic Procedure	524	
DTC P0455 EVAP CONTROL SYSTEM	487	DTC P0605 ECM	526	H
On Board Diagnosis Logic	487	Component Description	526	
DTC Confirmation Procedure	488	On Board Diagnosis Logic	526	
Diagnostic Procedure	489	DTC Confirmation Procedure	526	
DTC P0456 EVAP CONTROL SYSTEM	495	Diagnostic Procedure	527	I
On Board Diagnosis Logic	495	DTC P0643 SENSOR POWER SUPPLY	529	
DTC Confirmation Procedure	496	On Board Diagnosis Logic	529	J
Overall Function Check	497	DTC Confirmation Procedure	529	
Diagnostic Procedure	498	Wiring Diagram	530	
DTC P0460 FUEL LEVEL SENSOR	504	Diagnostic Procedure	532	
Component Description	504	DTC P0850 PNP SWITCH	535	K
On Board Diagnosis Logic	504	Component Description	535	
DTC Confirmation Procedure	504	CONSULT-II Reference Value in Data Monitor Mode		
Diagnostic Procedure	505		535	L
Removal and Installation	505	On Board Diagnosis Logic	535	
DTC P0461 FUEL LEVEL SENSOR	506	DTC Confirmation Procedure	535	
Component Description	506	Overall Function Check	536	
On Board Diagnosis Logic	506	Wiring Diagram	537	M
Overall Function Check	506	Diagnostic Procedure	538	
Diagnostic Procedure	507	DTC P1148, P1168 CLOSED LOOP CONTROL ...	541	
Removal and Installation	507	On Board Diagnosis Logic	541	
DTC P0462, P0463 FUEL LEVEL SENSOR	508	DTC P1211 TCS CONTROL UNIT	542	
Component Description	508	Description	542	
On Board Diagnosis Logic	508	On Board Diagnosis Logic	542	
DTC Confirmation Procedure	508	DTC Confirmation Procedure	542	
Diagnostic Procedure	509	Diagnostic Procedure	542	
Removal and Installation	509	DTC P1212 TCS COMMUNICATION LINE	543	
DTC P0500 VSS	510	Description	543	
Description	510	On Board Diagnosis Logic	543	
On Board Diagnosis Logic	510	DTC Confirmation Procedure	543	
DTC Confirmation Procedure	510	Diagnostic Procedure	543	
Overall Function Check	511	DTC P1217 ENGINE OVER TEMPERATURE	544	
Diagnostic Procedure	511	Description	544	
DTC P0506 ISC SYSTEM	512	CONSULT-II Reference Value in Data Monitor Mode		
Description	512		545	

On Board Diagnosis Logic	546	DTC Confirmation Procedure	586
Overall Function Check	547	Wiring Diagram	587
Wiring Diagram	548	Diagnostic Procedure	588
Diagnostic Procedure	550	Component Inspection	589
Main 12 Causes of Overheating	553	Removal and Installation	590
Component Inspection	554	DTC P1805 BRAKE SWITCH	591
DTC P1225 TP SENSOR	555	Description	591
Component Description	555	CONSULT-II Reference Value in Data Monitor Mode	591
On Board Diagnosis Logic	555	On Board Diagnosis Logic	591
DTC Confirmation Procedure	555	DTC Confirmation Procedure	591
Diagnostic Procedure	556	Wiring Diagram	592
Removal and Installation	556	Diagnostic Procedure	593
DTC P1226 TP SENSOR	557	Component Inspection	595
Component Description	557	DTC P2100, P2103 THROTTLE CONTROL MOTOR RELAY	596
On Board Diagnosis Logic	557	Component Description	596
DTC Confirmation Procedure	557	CONSULT-II Reference Value in Data Monitor Mode	596
Diagnostic Procedure	558	On Board Diagnosis Logic	596
Removal and Installation	558	DTC Confirmation Procedure	596
DTC P1402 EGR FUNCTION	559	Wiring Diagram	598
Description	559	Diagnostic Procedure	599
CONSULT-II Reference Value in Data Monitor Mode	561	DTC P2101 ELECTRIC THROTTLE CONTROL FUNCTION	602
On Board Diagnosis Logic	561	Description	602
DTC Confirmation Procedure	561	On Board Diagnosis Logic	602
Wiring Diagram	563	DTC Confirmation Procedure	602
Diagnostic Procedure	564	Wiring Diagram	603
DTC P1421 COLD START CONTROL	566	Diagnostic Procedure	605
Description	566	Component Inspection	608
On Board Diagnosis Logic	566	Removal and Installation	608
DTC Confirmation Procedure	566	DTC P2118 THROTTLE CONTROL MOTOR	609
Diagnostic Procedure	566	Component Description	609
DTC P1564 ASCD STEERING SWITCH	568	On Board Diagnosis Logic	609
Component Description	568	DTC Confirmation Procedure	609
CONSULT-II Reference Value in Data Monitor Mode	568	Wiring Diagram	610
On Board Diagnosis Logic	568	Diagnostic Procedure	612
DTC Confirmation Procedure	569	Component Inspection	613
Wiring Diagram	570	Removal and Installation	614
Diagnostic Procedure	572	DTC P2119 ELECTRIC THROTTLE CONTROL ACTUATOR	615
Component Inspection	575	Component Description	615
DTC P1572 ASCD BRAKE SWITCH	576	On Board Diagnosis Logic	615
Component Description	576	DTC Confirmation Procedure	615
CONSULT-II Reference Value in Data Monitor Mode	576	Diagnostic Procedure	616
On Board Diagnosis Logic	576	DTC P2122, P2123 APP SENSOR	617
DTC Confirmation Procedure	577	Component Description	617
Wiring Diagram	578	CONSULT-II Reference Value in Data Monitor Mode	617
Diagnostic Procedure	579	On Board Diagnosis Logic	617
Component Inspection	582	DTC Confirmation Procedure	618
DTC P1574 ASCD VEHICLE SPEED SENSOR	584	Wiring Diagram	619
Component Description	584	Diagnostic Procedure	621
On Board Diagnosis Logic	584	Component Inspection	623
DTC Confirmation Procedure	584	Removal and Installation	623
Diagnostic Procedure	585	DTC P2127, P2128 APP SENSOR	624
DTC P1800 VIAS CONTROL SOLENOID VALVE	586	Component Description	624
Component Description	586	CONSULT-II Reference Value in Data Monitor Mode	624
CONSULT-II Reference Value in Data Monitor Mode	586	On Board Diagnosis Logic	617
On Board Diagnosis Logic	586	DTC Confirmation Procedure	618
		Wiring Diagram	619
		Diagnostic Procedure	621
		Component Inspection	623
		Removal and Installation	623

On Board Diagnosis Logic	624	CONSULT-II Reference Value in Data Monitor Mode	673	A
DTC Confirmation Procedure	625	Wiring Diagram	674	
Wiring Diagram	626	Diagnostic Procedure	675	
Diagnostic Procedure	628	FUEL INJECTOR	678	EC
Component Inspection	631	Component Description	678	
Removal and Installation	631	CONSULT-II Reference Value in Data Monitor Mode	678	
DTC P2135 TP SENSOR	632	Wiring Diagram	679	C
Component Description	632	Diagnostic Procedure	680	
CONSULT-II Reference Value in Data Monitor Mode	632	Component Inspection	684	
On Board Diagnosis Logic	632	Removal and Installation	684	D
DTC Confirmation Procedure	633	FUEL PUMP	685	
Wiring Diagram	634	Description	685	
Diagnostic Procedure	636	CONSULT-II Reference Value in Data Monitor Mode	685	E
Component Inspection	639	Wiring Diagram	686	
Removal and Installation	639	Diagnostic Procedure	687	
DTC P2138 APP SENSOR	640	Component Inspection	690	F
Component Description	640	Removal and Installation	690	
CONSULT-II Reference Value in Data Monitor Mode	640	IGNITION SIGNAL	691	
On Board Diagnosis Logic	640	Component Description	691	G
DTC Confirmation Procedure	641	Wiring Diagram	692	
Wiring Diagram	642	Diagnostic Procedure	697	
Diagnostic Procedure	644	Component Inspection	702	H
Component Inspection	647	Removal and Installation	703	
Removal and Installation	647	REFRIGERANT PRESSURE SENSOR	704	
DTC P2A00, P2A03 A/F SENSOR 1	648	Component Description	704	I
Component Description	648	Wiring Diagram	705	
CONSULT-II Reference Value in Data Monitor Mode	648	Diagnostic Procedure	706	
On Board Diagnosis Logic	648	Removal and Installation	709	J
DTC Confirmation Procedure	649	VIAS	710	
Wiring Diagram	650	Description	710	
Diagnostic Procedure	654	CONSULT-II Reference Value in Data Monitor Mode	711	K
Removal and Installation	660	Wiring Diagram	712	
ASC D BRAKE SWITCH	661	Diagnostic Procedure	714	
Component Description	661	Component Inspection	718	L
CONSULT-II Reference Value in Data Monitor Mode	661	Removal and Installation	718	
Wiring Diagram	662	MIL AND DATA LINK CONNECTOR	719	
Diagnostic Procedure	663	Wiring Diagram	719	M
Component Inspection	667	SERVICE DATA AND SPECIFICATIONS (SDS) ...	721	
ASC D INDICATOR	668	Fuel Pressure	721	
Component Description	668	Idle Speed and Ignition Timing	721	
CONSULT-II Reference Value in Data Monitor Mode	668	Calculated Load Value	721	
Wiring Diagram	669	Mass Air Flow Sensor	721	
Diagnostic Procedure	670	Intake Air Temperature Sensor	721	
ELECTRICAL LOAD SIGNAL	671	Engine Coolant Temperature Sensor	721	
Description	671	EGR Temperature Sensor	721	
CONSULT-II Reference Value in Data Monitor Mode	671	Air Fuel Ratio (A/F) Sensor 1 Heater	721	
Diagnostic Procedure	671	Heated Oxygen sensor 2 Heater	721	
ELECTRONIC CONTROLLED ENGINE MOUNT	673	Crankshaft Position Sensor (POS)	722	
System Description	673	Camshaft Position Sensor (PHASE)	722	
		Throttle Control Motor	722	
		Fuel Injector	722	
		Fuel Pump	722	

INDEX FOR DTC

INDEX FOR DTC

PF0:00024

DTC No. Index

UBS00P01

NOTE:

- If DTC U1000 or U1001 is displayed with other DTC, first perform the trouble diagnosis for DTC U1000, U1001. Refer to [EC-159, "DTC U1000, U1001 CAN COMMUNICATION LINE"](#) .
- If DTC U1010 is displayed with other DTC, first perform the trouble diagnosis for DTC U1010. Refer to [EC-162, "DTC U1010 CAN COMMUNICATION"](#) .

DTC*1		Items (CONSULT-II screen terms)	Reference page
CONSULT-II GST*2	ECM*3		
U1000	1000*4	CAN COMM CIRCUIT	EC-159
U1001	1001*4	CAN COMM CIRCUIT	EC-159
U1010	1010	CONTROL UNIT (CAN)	EC-162
P0000	0000	NO DTC IS DETECTED. FURTHER TESTING MAY BE REQUIRED.	—
P0011	0011	INT/V TIM CONT-B1	EC-164
P0021	0021	INT/V TIM CONT-B2	EC-164
P0031	0031	A/F SEN1 HTR (B1)	EC-168
P0032	0032	A/F SEN1 HTR (B1)	EC-168
P0037	0037	HO2S2 HTR (B1)	EC-176
P0038	0038	HO2S2 HTR (B1)	EC-176
P0051	0051	A/F SEN1 HTR (B2)	EC-168
P0052	0052	A/F SEN1 HTR (B2)	EC-168
P0057	0057	HO2S2 HTR (B2)	EC-176
P0058	0058	HO2S2 HTR (B2)	EC-176
P0075	0075	INT/V TIM V/CIR-B1	EC-185
P0081	0081	INT/V TIM V/CIR-B2	EC-185
P0101	0101	MAF SEN/CIRCUIT	EC-192
P0102	0102	MAF SEN/CIRCUIT	EC-202
P0103	0103	MAF SEN/CIRCUIT	EC-202
P0112	0112	IAT SEN/CIRCUIT	EC-211
P0113	0113	IAT SEN/CIRCUIT	EC-211
P0117	0117	ECT SEN/CIRC	EC-216
P0118	0118	ECT SEN/CIRC	EC-216
P0122	0122	TP SEN 2/CIRC	EC-222
P0123	0123	TP SEN 2/CIRC	EC-222
P0125	0125	ECT SENSOR	EC-230
P0127	0127	IAT SENSOR	EC-234
P0128	0128	THERMSTAT FNCTN	EC-237
P0130	0130	A/F SENSOR1 (B1)	EC-239
P0131	0131	A/F SENSOR1 (B1)	EC-250
P0132	0132	A/F SENSOR1 (B1)	EC-260
P0133	0133	A/F SENSOR1 (B1)	EC-270
P0137	0137	HO2S2 (B1)	EC-283
P0138	0138	HO2S2 (B1)	EC-295

INDEX FOR DTC

DTC*1		Items (CONSULT-II screen terms)	Reference page
CONSULT-II GST*2	ECM*3		
P0139	0139	HO2S2 (B1)	EC-310
P0150	0150	A/F SENSOR1 (B2)	EC-239
P0151	0151	A/F SENSOR1 (B2)	EC-250
P0152	0152	A/F SENSOR1 (B2)	EC-260
P0153	0153	A/F SENSOR1 (B2)	EC-270
P0157	0157	HO2S2 (B2)	EC-283
P0158	0158	HO2S2 (B2)	EC-295
P0159	0159	HO2S2 (B2)	EC-310
P0171	0171	FUEL SYS-LEAN-B1	EC-322
P0172	0172	FUEL SYS-RICH-B1	EC-334
P0174	0174	FUEL SYS-LEAN-B2	EC-322
P0175	0175	FUEL SYS-RICH-B2	EC-334
P0181	0181	FTT SENSOR	EC-346
P0182	0182	FTT SEN/CIRCUIT	EC-352
P0183	0183	FTT SEN/CIRCUIT	EC-352
P0222	0222	TP SEN 1/CIRC	EC-357
P0223	0223	TP SEN 1/CIRC	EC-357
P0300	0300	MULTI CYL MISFIRE	EC-365
P0301	0301	CYL 1 MISFIRE	EC-365
P0302	0302	CYL 2 MISFIRE	EC-365
P0303	0303	CYL 3 MISFIRE	EC-365
P0304	0304	CYL 4 MISFIRE	EC-365
P0305	0305	CYL 5 MISFIRE	EC-365
P0306	0306	CYL 6 MISFIRE	EC-365
P0327	0327	KNOCK SEN/CIRC-B1	EC-374
P0328	0328	KNOCK SEN/CIRC-B1	EC-374
P0335	0335	CKP SEN/CIRCUIT	EC-379
P0340	0340	CMP SEN/CIRC-B1	EC-387
P0345	0345	CMP SEN/CIRC-B2	EC-387
P0400	0400	EGR SYSTEM	EC-397
P0403	0403	EGR VOL CON/V CIR	EC-405
P0405	0405	EGR TEMP SEN/CIRC	EC-412
P0406	0406	EGR TEMP SEN/CIRC	EC-412
P0420	0420	TW CATALYST SYS-B1	EC-419
P0430	0430	TW CATALYST SYS-B2	EC-419
P0441	0441	EVAP PURG FLOW/MON	EC-425
P0442	0442	EVAP SMALL LEAK	EC-431
P0443	0443	PURG VOLUME CONT/V	EC-439
P0444	0444	PURG VOLUME CONT/V	EC-447
P0445	0445	PURG VOLUME CONT/V	EC-447
P0447	0447	VENT CONTROL VALVE	EC-454
P0448	0448	VENT CONTROL VALVE	EC-461

A
EC
C
D
E
F
G
H
I
J
K
L
M

INDEX FOR DTC

DTC*1		Items (CONSULT-II screen terms)	Reference page
CONSULT-II GST*2	ECM*3		
P0451	0451	EVAP SYS PRES SEN	EC-468
P0452	0452	EVAP SYS PRES SEN	EC-472
P0453	0453	EVAP SYS PRES SEN	EC-479
P0455	0455	EVAP GROSS LEAK	EC-487
P0456	0456	EVAP VERY SML LEAK	EC-495
P0460	0460	FUEL LEV SEN SLOSH	EC-504
P0461	0461	FUEL LEVEL SENSOR	EC-506
P0462	0462	FUEL LEVL SEN/CIRC	EC-508
P0463	0463	FUEL LEVL SEN/CIRC	EC-508
P0500	0500	VEH SPEED SEN/CIRC	EC-510
P0506	0506	ISC SYSTEM	EC-512
P0507	0507	ISC SYSTEM	EC-514
P0550	0550	PW ST P SEN/CIRC	EC-516
P0603	0603	ECM BACK UP/CIRCUIT	EC-522
P0605	0605	ECM	EC-526
P0643	0643	SENSOR POWER/CIRC	EC-529
P0705	0705	PNP SW/CIRC	AT-91
P0710	0710	ATF TEMP SEN/CIRC	AT-96
P0711	0711	FLUID TEMP SEN	AT-101
P0717	0717	TURBINE SENSOR	AT-106
P0722	0722	VHCL SPEED SEN-AT	AT-110
P0731	0731	A/T 1ST GR FNCTN	AT-116
P0732	0732	A/T 2ND GR FNCTN	AT-119
P0733	0733	A/T 3RD GR FNCTN	AT-124
P0734	0734	A/T 4TH GR FNCTN	AT-129
P0735	0735	A/T 5TH GR FNCTN	AT-133
P0744	0744	A/T TCC S/V FNCTN	AT-138
P0745	0745	PC SOL A(L/PRESS)	AT-141
P0750	0750	SHIFT SOL A	AT-146
P0755	0755	SHIFT SOL B	AT-151
P0760	0760	SHIFT SOL C	AT-156
P0762	0762	SFT SOL C STUCK ON	AT-161
P0765	0765	SHIFT SOL D	AT-166
P0770	0770	SHIFT SOL E	AT-171
P0775	0775	PC SOL B(SFT/PRS)	AT-176
P0780	0780	SHIFT	AT-181
P0795	0795	PC SOL C(TCC&SFT)	AT-185
P0797	0797	PC SOL C STC ON	AT-190
P0850	0850	P-N POS SW/CIRCUIT	EC-535
P0882	0882	TCM POWER INPT SIG	AT-199
P1148	1148	CLOSED LOOP-B1	EC-541
P1168	1168	CLOSED LOOP-B2	EC-541

INDEX FOR DTC

DTC*1		Items (CONSULT-II screen terms)	Reference page
CONSULT-II GST*2	ECM*3		
P1211	1211	TCS C/U FUNCTN	EC-542
P1212	1212	TCS/CIRC	EC-543
P1217	1217	ENG OVER TEMP	EC-544
P1225	1225	CTP LEARNING	EC-555
P1226	1226	CTP LEARNING	EC-557
P1402	1402	EGR SYSTEM	EC-559
P1421	1421	COLD START CONTROL	EC-566
P1564	1564	ASCD SW	EC-568
P1572	1572	ASCD BRAKE SW	EC-576
P1574	1574	ASCD VHL SPD SEN	EC-584
P1610 - P1615	1610 - 1615	NATS MALFUNCTION	BL-203
P1800	1800	VIAS S/V CIRC	EC-586
P1805	1805	BRAKE SW/CIRCUIT	EC-591
P2100	2100	ETC MOT PWR	EC-596
P2101	2101	ETC FUNCTION/CIRC	EC-602
P2103	2103	ETC MOT PWR	EC-596
P2118	2118	ETC MOT	EC-609
P2119	2119	ETC ACTR	EC-615
P2122	2122	APP SEN 1/CIRC	EC-617
P2123	2123	APP SEN 1/CIRC	EC-617
P2127	2127	APP SEN 2/CIRC	EC-624
P2128	2128	APP SEN 2/CIRC	EC-624
P2135	2135	TP SENSOR	EC-632
P2138	2138	APP SENSOR	EC-640
P2A00	2A00	A/F SENSOR 1 (B1)	EC-648
P2A03	2A03	A/F SENSOR 1 (B2)	EC-648

*1: 1st trip DTC No. is the same as DTC No.

*2: This number is prescribed by SAE J2012.

*3: In Diagnostic Test Mode II (Self-diagnostic results), this number is controlled by NISSAN.

*4: The troubleshooting for this DTC needs CONSULT-II.

A
EC
C
D
E
F
G
H
I
J
K
L
M

INDEX FOR DTC

UBS00POJ

Alphabetical Index

NOTE:

- If DTC U1000 or U1001 is displayed with other DTC, first perform the trouble diagnosis for DTC U1000, U1001. Refer to [EC-159, "DTC U1000, U1001 CAN COMMUNICATION LINE"](#) .
- If DTC U1010 is displayed with other DTC, first perform the trouble diagnosis for DTC U1010. Refer to [EC-162, "DTC U1010 CAN COMMUNICATION"](#) .

Items (CONSULT-II screen terms)	DTC*1		Reference page
	CONSULT-II GST*2	ECM*3	
A/F SENSOR1 (B1)	P0130	0130	EC-239
A/F SENSOR1 (B1)	P0131	0131	EC-250
A/F SENSOR1 (B1)	P0132	0132	EC-260
A/F SENSOR1 (B1)	P0133	0133	EC-270
A/F SENSOR1 (B2)	P0150	0150	EC-239
A/F SENSOR1 (B2)	P0151	0151	EC-250
A/F SENSOR1 (B2)	P0152	0152	EC-260
A/F SENSOR1 (B2)	P0153	0153	EC-270
A/F SENSOR1 (B1)	P2A00	2A00	EC-648
A/F SENSOR1 (B2)	P2A03	2A03	EC-648
A/F SEN1 HTR (B1)	P0031	0031	EC-168
A/F SEN1 HTR (B1)	P0032	0032	EC-168
A/F SEN1 HTR (B2)	P0051	0051	EC-168
A/F SEN1 HTR (B2)	P0052	0052	EC-168
A/T 1ST GR FNCTN	P0731	0731	AT-116
A/T 2ND GR FNCTN	P0732	0732	AT-119
A/T 3RD GR FNCTN	P0733	0733	AT-124
A/T 4TH GR FNCTN	P0734	0734	AT-129
A/T 5HT GR FNCTN	P0735	0735	AT-133
A/T TCC S/V FNCTN	P0744	0744	AT-138
APP SEN 1/CIRC	P2122	2122	EC-617
APP SEN 1/CIRC	P2123	2123	EC-617
APP SEN 2/CIRC	P2127	2127	EC-624
APP SEN 2/CIRC	P2128	2128	EC-624
APP SENSOR	P2138	2138	EC-640
ASCD BRAKE SW	P1572	1572	EC-576
ASCD SW	P1564	1564	EC-568
ASCD VHL SPD SEN	P1574	1574	EC-584
ATF TEMP SEN/CIRC	P0710	0710	AT-96
BRAKE SW/CIRCUIT	P1805	1805	EC-591
CAN COMM CIRCUIT	U1000	1000*4	EC-159
CAN COMM CIRCUIT	U1001	1001*4	EC-159
CKP SEN/CIRCUIT	P0335	0335	EC-379
CLOSED LOOP-B1	P1148	1148	EC-541
CLOSED LOOP-B2	P1168	1168	EC-541
CMP SEN/CIRC-B1	P0340	0340	EC-387
CMP SEN/CIRC-B2	P0345	0345	EC-387

INDEX FOR DTC

Items (CONSULT-II screen terms)	DTC*1		Reference page
	CONSULT-II GST*2	ECM*3	
COLD START CONTROL	P1421	1421	EC-566
CONTROL UNIT (CAN)	U1010	1010	EC-162
CTP LEARNING	P1225	1225	EC-555
CTP LEARNING	P1226	1226	EC-557
CYL 1 MISFIRE	P0301	0301	EC-365
CYL 2 MISFIRE	P0302	0302	EC-365
CYL 3 MISFIRE	P0303	0303	EC-365
CYL 4 MISFIRE	P0304	0304	EC-365
CYL 5 MISFIRE	P0305	0305	EC-365
CYL 6 MISFIRE	P0306	0306	EC-365
ECM	P0605	0605	EC-526
ECM BACK UP/CIRCUIT	P0603	0603	EC-522
ECT SEN/CIRC	P0117	0117	EC-216
ECT SEN/CIRC	P0118	0118	EC-216
ECT SENSOR	P0125	0125	EC-230
EGR SYSTEM	P0400	0400	EC-397
EGR SYSTEM	P1402	1402	EC-559
EGR TEMP SEN/CIRC	P0405	0405	EC-412
EGR TEMP SEN/CIRC	P0406	0406	EC-412
EGR VOL CON/V CIR	P0403	0403	EC-405
ENG OVER TEMP	P1217	1217	EC-544
ETC ACTR	P2119	2119	EC-615
ETC FUNCTION/CIRC	P2101	2101	EC-602
ETC MOT	P2118	2118	EC-609
ETC MOT PWR	P2103	2103	EC-596
ETC MOT PWR	P2100	2100	EC-596
EVAP GROSS LEAK	P0455	0455	EC-487
EVAP PURG FLOW/MON	P0441	0441	EC-425
EVAP SMALL LEAK	P0442	0442	EC-431
EVAP SYS PRES SEN	P0451	0451	EC-468
EVAP SYS PRES SEN	P0452	0452	EC-472
EVAP SYS PRES SEN	P0453	0453	EC-479
EVAP VERY SML LEAK	P0456	0456	EC-495
FLUID TEMP SEN	P0711	0711	AT-101
FTT SEN/CIRCUIT	P0182	0182	EC-352
FTT SEN/CIRCUIT	P0183	0183	EC-352
FTT SENSOR	P0181	0181	EC-346
FUEL LEV SEN SLOSH	P0460	0460	EC-504
FUEL LEVEL SENSOR	P0461	0461	EC-506
FUEL LEVL SEN/CIRC	P0462	0462	EC-508
FUEL LEVL SEN/CIRC	P0463	0463	EC-508
FUEL SYS-LEAN-B1	P0171	0171	EC-322

A
EC
C
D
E
F
G
H
I
J
K
L
M

INDEX FOR DTC

Items (CONSULT-II screen terms)	DTC*1		Reference page
	CONSULT-II GST*2	ECM*3	
FUEL SYS-LEAN-B2	P0174	0174	EC-322
FUEL SYS-RICH-B1	P0172	0172	EC-334
FUEL SYS-RICH-B2	P0175	0175	EC-334
HO2S2 (B1)	P0137	0137	EC-283
HO2S2 (B1)	P0138	0138	EC-295
HO2S2 (B1)	P0139	0139	EC-310
HO2S2 (B2)	P0157	0157	EC-283
HO2S2 (B2)	P0158	0158	EC-295
HO2S2 (B2)	P0159	0159	EC-310
HO2S2 HTR (B1)	P0037	0037	EC-176
HO2S2 HTR (B1)	P0038	0038	EC-176
HO2S2 HTR (B2)	P0057	0057	EC-176
HO2S2 HTR (B2)	P0058	0058	EC-176
IAT SEN/CIRCUIT	P0112	0112	EC-211
IAT SEN/CIRCUIT	P0113	0113	EC-211
IAT SENSOR	P0127	0127	EC-234
INT/V TIM CONT-B1	P0011	0011	EC-164
INT/V TIM CONT-B2	P0021	0021	EC-164
INT/V TIM V/CIR-B1	P0075	0075	EC-185
INT/V TIM V/CIR-B2	P0081	0081	EC-185
ISC SYSTEM	P0506	0506	EC-512
ISC SYSTEM	P0507	0507	EC-514
KNOCK SEN/CIRC-B1	P0327	0327	EC-374
KNOCK SEN/CIRC-B1	P0328	0328	EC-374
MAF SEN/CIRCUIT	P0101	0101	EC-192
MAF SEN/CIRCUIT	P0102	0102	EC-202
MAF SEN/CIRCUIT	P0103	0103	EC-202
MULTI CYL MISFIRE	P0300	0300	EC-365
NATS MALFUNCTION	P1610 - P1615	1610 - 1615	BL-203
NO DTC IS DETECTED. FURTHER TESTING MAY BE REQUIRED.	P0000	0000	—
PC SOL A(L/PRESS)	P0745	0745	AT-141
PC SOL B(SFT/PRS)	P0775	0775	AT-176
PC SOL C(TCC&SFT)	P0795	0795	AT-185
PC SOL C STC ON	P0797	0797	AT-190
P-N POS SW/CIRCUIT	P0850	0850	EC-535
PNP SW/CIRC	P0705	0705	AT-91
PURG VOLUME CONT/V	P0443	0443	EC-439
PURG VOLUME CONT/V	P0444	0444	EC-447
PURG VOLUME CONT/V	P0445	0445	EC-447
PW ST P SEN/CIRC	P0550	0550	EC-516
SENSOR POWER/CIRC	P0643	0643	EC-529

INDEX FOR DTC

Items (CONSULT-II screen terms)	DTC*1		Reference page
	CONSULT-II GST*2	ECM*3	
SFT SOL C STUCK ON	P0762	0762	AT-161
SHIFT	P0780	0780	AT-181
SHIFT SOL A	P0750	0750	AT-146
SHIFT SOL B	P0755	0755	AT-151
SHIFT SOL C	P0760	0760	AT-156
SHIFT SOL D	P0765	0765	AT-166
SHIFT SOL E	P0770	0770	AT-171
TCM POWER INPT SIG	P0882	0882	AT-199
TCS C/U FUNCTN	P1211	1211	EC-542
TCS/CIRC	P1212	1212	EC-543
THERMSTAT FNCTN	P0128	0128	EC-237
TP SEN 1/CIRC	P0222	0222	EC-357
TP SEN 1/CIRC	P0223	0223	EC-357
TP SEN 2/CIRC	P0122	0122	EC-222
TP SEN 2/CIRC	P0123	0123	EC-222
TP SENSOR	P2135	2135	EC-632
TURBINE SENSOR	P0717	0717	AT-106
TW CATALYST SYS-B1	P0420	0420	EC-419
TW CATALYST SYS-B2	P0430	0430	EC-419
VEH SPEED SEN/CIRC	P0500	0500	EC-510
VENT CONTROL VALVE	P0447	0447	EC-454
VENT CONTROL VALVE	P0448	0448	EC-461
VHCL SPEED SEN-AT	P0722	0722	AT-110
VIAS S/V CIRC	P1800	1800	EC-586

*1: 1st trip DTC No. is the same as DTC No.

*2: This number is prescribed by SAE J2012.

*3: In Diagnostic Test Mode II (Self-diagnostic results), this number is controlled by NISSAN.

*4: The troubleshooting for this DTC needs CONSULT-II.

A
EC
C
D
E
F
G
H
I
J
K
L
M

PRECAUTIONS

PRECAUTIONS

PF:00001

Precautions for Supplemental Restraint System (SRS) “AIR BAG” and “SEAT BELT PRE-TENSIONER”

UBS00P0K

The Supplemental Restraint System such as “AIR BAG” and “SEAT BELT PRE-TENSIONER”, used along with a front seat belt, helps to reduce the risk or severity of injury to the driver and front passenger for certain types of collision. This system includes seat belt switch inputs and dual stage front air bag modules. The SRS system uses the seat belt switches to determine the front air bag deployment, and may only deploy one front air bag, depending on the severity of a collision and whether the front occupants are belted or unbelted. Information necessary to service the system safely is included in the SRS and SB section of this Service Manual.

WARNING:

- To avoid rendering the SRS inoperative, which could increase the risk of personal injury or death in the event of a collision which would result in air bag inflation, all maintenance must be performed by an authorized NISSAN/INFINITI dealer.
- Improper maintenance, including incorrect removal and installation of the SRS, can lead to personal injury caused by unintentional activation of the system. For removal of Spiral Cable and Air Bag Module, see the SRS section.
- Do not use electrical test equipment on any circuit related to the SRS unless instructed to in this Service Manual. SRS wiring harnesses can be identified by yellow and/or orange harnesses or harness connectors.

On Board Diagnostic (OBD) System of Engine and A/T

UBS00P0L

The ECM has an on board diagnostic system. It will light up the malfunction indicator lamp (MIL) to warn the driver of a malfunction causing emission deterioration.

CAUTION:

- Be sure to turn the ignition switch OFF and disconnect the negative battery cable before any repair or inspection work. The open/short circuit of related switches, sensors, solenoid valves, etc. will cause the MIL to light up.
- Be sure to connect and lock the connectors securely after work. A loose (unlocked) connector will cause the MIL to light up due to the open circuit. (Be sure the connector is free from water, grease, dirt, bent terminals, etc.)
- Certain systems and components, especially those related to OBD, may use a new style slide-locking type harness connector. For description and how to disconnect, refer to [PG-76, "HARNESS CONNECTOR"](#).
- Be sure to route and secure the harnesses properly after work. The interference of the harness with a bracket, etc. may cause the MIL to light up due to the short circuit.
- Be sure to connect rubber tubes properly after work. A misconnected or disconnected rubber tube may cause the MIL to light up due to the malfunction of the EVAP system or fuel injection system, etc.
- Be sure to erase the unnecessary malfunction information (repairs completed) from the ECM and TCM (Transmission control module) before returning the vehicle to the customer.

Precaution

UBS00P0M

- Always use a 12 volt battery as power source.
- Do not attempt to disconnect battery cables while engine is running.
- Before connecting or disconnecting the ECM harness connector, turn ignition switch OFF and disconnect negative battery cable. Failure to do so may damage the ECM because battery voltage is applied to ECM even if ignition switch is turned OFF.
- Before removing parts, turn ignition switch OFF and then disconnect negative battery cable.

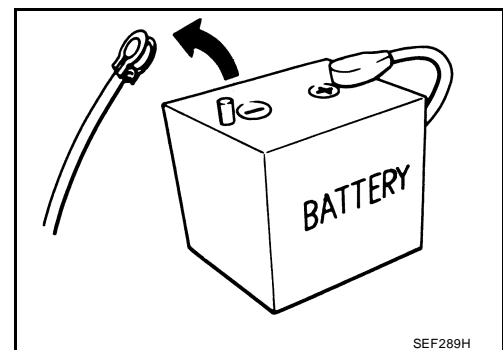

SEF289H

PRECAUTIONS

- Do not disassemble ECM.
- If a battery cable is disconnected, the memory will return to the ECM value.
The ECM will now start to self-control at its initial value. Engine operation can vary slightly when the terminal is disconnected. However, this is not an indication of a malfunction. Do not replace parts because of a slight variation.
- If the battery is disconnected, the following emission-related diagnostic information will be lost within 24 hours.
 - Diagnostic trouble codes
 - 1st trip diagnostic trouble codes
 - Freeze frame data
 - 1st trip freeze frame data
 - System readiness test (SRT) codes
 - Test values

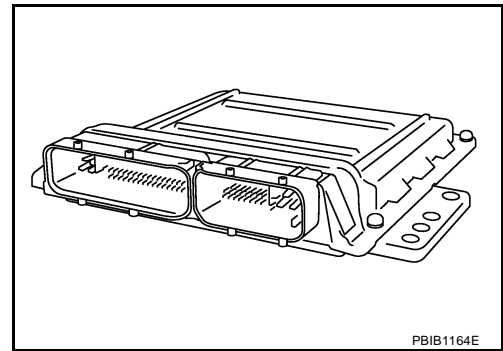

- When connecting ECM harness connector, fasten it securely with levers as far as they will go as shown in the figure.

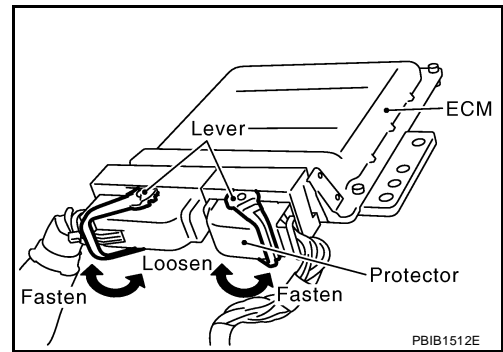

- When connecting or disconnecting pin connectors into or from ECM, take care not to damage pin terminals (bend or break).
Make sure that there are not any bends or breaks on ECM pin terminal, when connecting pin connectors.
- Securely connect ECM harness connectors.
A poor connection can cause an extremely high (surge) voltage to develop in coil and condenser, thus resulting in damage to ICs.
- Keep engine control system harness at least 10 cm (4 in) away from adjacent harness, to prevent engine control system malfunctions due to receiving external noise, degraded operation of ICs, etc.

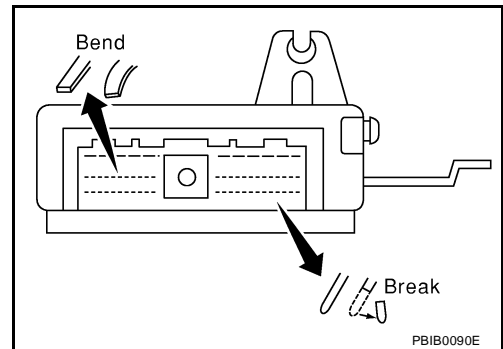

- Keep engine control system parts and harness dry.
- Before replacing ECM, perform ECM Terminals and Reference Value inspection and make sure ECM functions properly. Refer to [EC-109, "ECM Terminals and Reference Value"](#).
- Handle mass air flow sensor carefully to avoid damage.
- Do not disassemble mass air flow sensor.
- Do not clean mass air flow sensor with any type of detergent.
- Do not disassemble electric throttle control actuator.
- Even a slight leak in the air intake system can cause serious incidents.
- Do not shock or jar the camshaft position sensor (PHASE), crankshaft position sensor (POS).

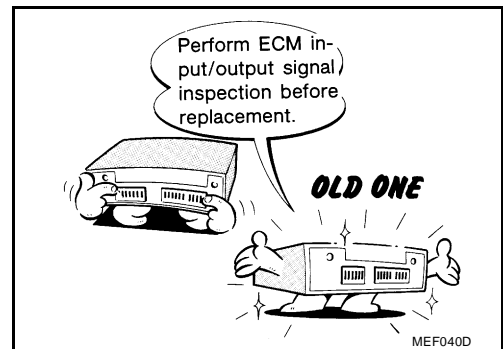

PRECAUTIONS

- After performing each TROUBLE DIAGNOSIS, perform DTC Confirmation Procedure or Overall Function Check. The DTC should not be displayed in the DTC Confirmation Procedure if the repair is completed. The Overall Function Check should be a good result if the repair is completed.

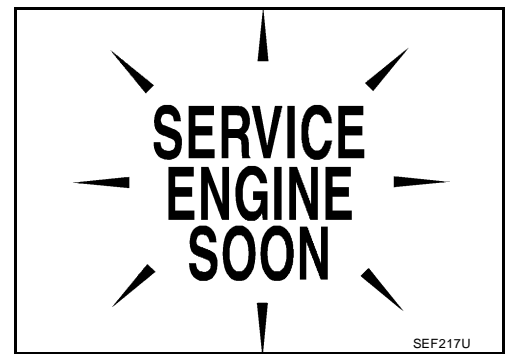

- When measuring ECM signals with a circuit tester, never allow the two tester probes to contact. Accidental contact of probes will cause a short circuit and damage the ECM power transistor.
- Do not use ECM ground terminals when measuring input/output voltage. Doing so may result in damage to the ECM's transistor. Use a ground other than ECM terminals, such as the ground.

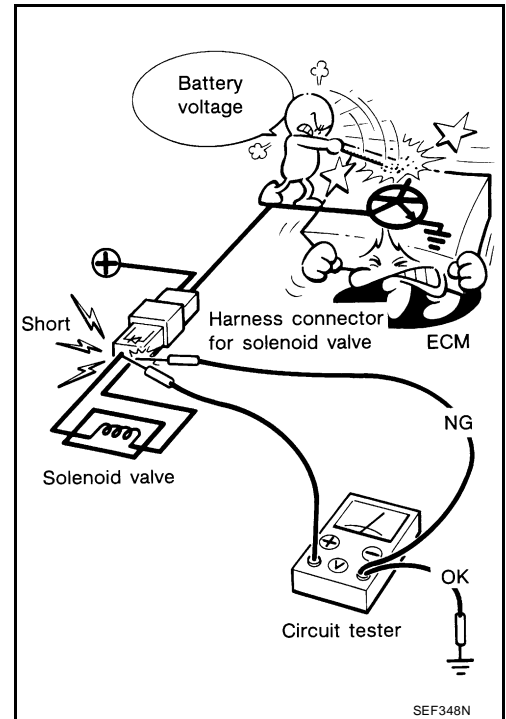

- B1 indicates the bank 1, B2 indicates the bank 2 as shown in the figure.

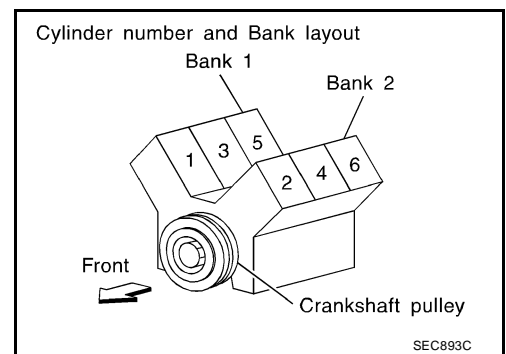

PRECAUTIONS

- Do not operate fuel pump when there is no fuel in lines.
- Tighten fuel hose clamps to the specified torque.

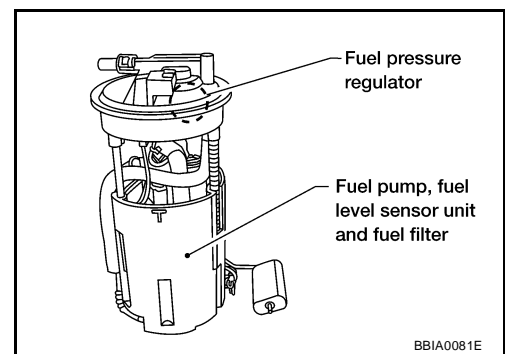

- Do not depress accelerator pedal when starting.
- Immediately after starting, do not rev up engine unnecessarily.
- Do not rev up engine just prior to shutdown.



- When installing C.B. ham radio or a mobile phone, be sure to observe the following as it may adversely affect electronic control systems depending on installation location.
 - Keep the antenna as far as possible from the electronic control units.
 - Keep the antenna feeder line more than 20 cm (8 in) away from the harness of electronic controls. Do not let them run parallel for a long distance.
 - Adjust the antenna and feeder line so that the standing-wave ratio can be kept smaller.
 - Be sure to ground the radio to vehicle body.

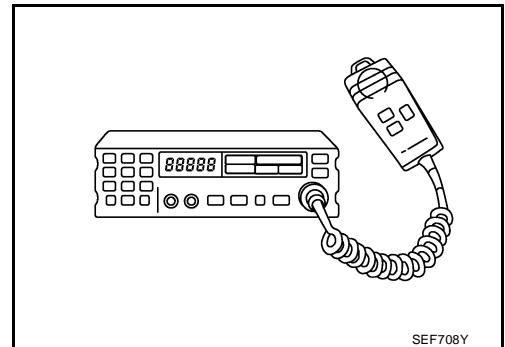

PREPARATION



PREPARATION

PF0:00002

Special Service Tools

UBS00P0N

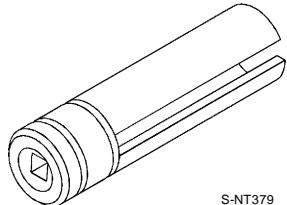
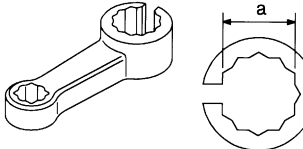
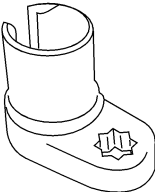
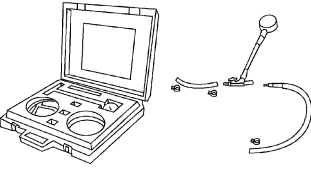
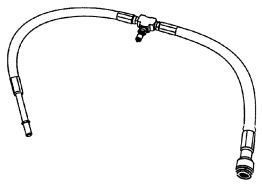
The actual shapes of Kent-Moore tools may differ from those of special service tools illustrated here.

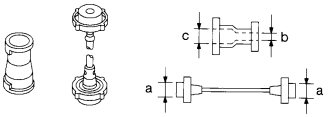
Tool number (Kent-Moore No.) Tool name	Description	
KV10117100 (J-36471-A) Heated oxygen sensor wrench	 <p style="text-align: center;">S-NT379</p>	Loosening or tightening heated oxygen sensor with 22 mm (0.87 in) hexagon nut
KV10114400 (J-38365) Heated oxygen sensor wrench	 <p style="text-align: center;">S-NT636</p>	Loosening or tightening heated oxygen sensor a: 22 mm (0.87 in)
(J-44626) Air fuel ratio (A/F) sensor wrench	 <p style="text-align: center;">LEM054</p>	Loosening or tightening air fuel ratio (A/F) sensor 1
(J-44321) Fuel pressure gauge kit	 <p style="text-align: center;">LEC642</p>	Checking fuel pressure
(J-44321-6) Fuel pressure adapter	 <p style="text-align: center;">LBIA0376E</p>	Connecting fuel pressure gauge to quick connector type fuel lines.
(J-45488) Quick connector re-lease	 <p style="text-align: center;">PBIC0198E</p>	Remove fuel tube quick connectors in engine room.
EG17650301 (J-33984-A) Radiator cap tester adapter	 <p style="text-align: center;">S-NT564</p>	Adapting radiator cap tester to radiator cap and radiator filler neck a: 28 (1.10) dia. b: 31.4 (1.236) dia. c: 41.3 (1.626) dia. Unit: mm (in)

PREPARATION

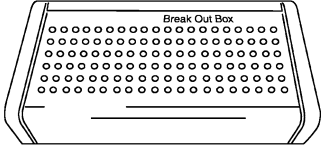
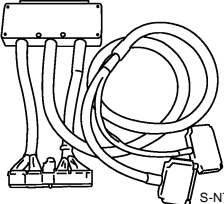
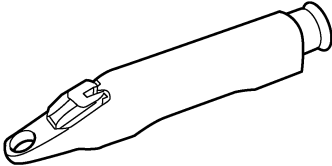

Tool number (Kent-Moore No.) Tool name	Description	
KV109E0010 (J-46209) Break-out box	 <p style="text-align: center;">S-NT825</p>	Measuring the ECM signals with a circuit tester
KV109E0080 (J-45819) Y-cable adapter	 <p style="text-align: center;">S-NT826</p>	Measuring the ECM signals with a circuit tester
(J-23688) Engine coolant refrac- tometer	 <p style="text-align: center;">WBIA0539E</p>	Checking concentration of ethylene glycol in the en- gine coolant

A
EC
C
D
E
F
G
H
I
J
K
L
M

PREPARATION

Commercial Service Tools

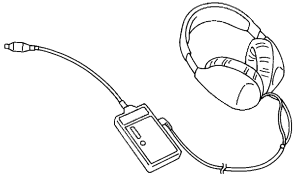
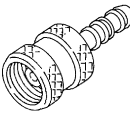
UBS00P00

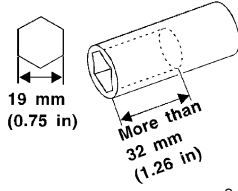
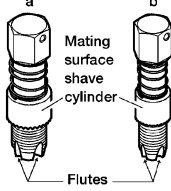
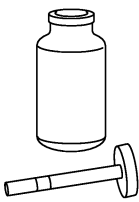
Tool name (Kent-Moore No.)	Description	
Leak detector i.e.: (J-41416)	 <p style="text-align: center;">S-NT703</p>	Locating the EVAP leak
EVAP service port adapter i.e.: (J-41413-OBID)	 <p style="text-align: center;">S-NT704</p>	Applying positive pressure through EVAP service port
Fuel filler cap adapter i.e.: (MLR-8382)	 <p style="text-align: center;">S-NT815</p>	Checking fuel tank vacuum relief valve opening pressure
Socket wrench	 <p style="text-align: center;">S-NT705</p>	Removing and installing engine coolant temperature sensor
Oxygen sensor thread cleaner i.e.: (J-43897-18) (J-43897-12)	 <p style="text-align: center;">AEM488</p>	Reconditioning the exhaust system threads before installing a new oxygen sensor. Use with anti-seize lubricant shown below. a: 18 mm diameter with pitch 1.5 mm for Zirconia Oxygen Sensor b: 12 mm diameter with pitch 1.25 mm for Titania Oxygen Sensor
Anti-seize lubricant i.e.: (Permatex™ 133AR or equivalent meeting MIL specification MIL-A-907)	 <p style="text-align: center;">S-NT779</p>	Lubricating oxygen sensor thread cleaning tool when reconditioning exhaust system threads.

ENGINE CONTROL SYSTEM

System Diagram

PF2:23710

UBS00P0P

A

EC

C

D

E

F

G

H

I

J

K

L

M

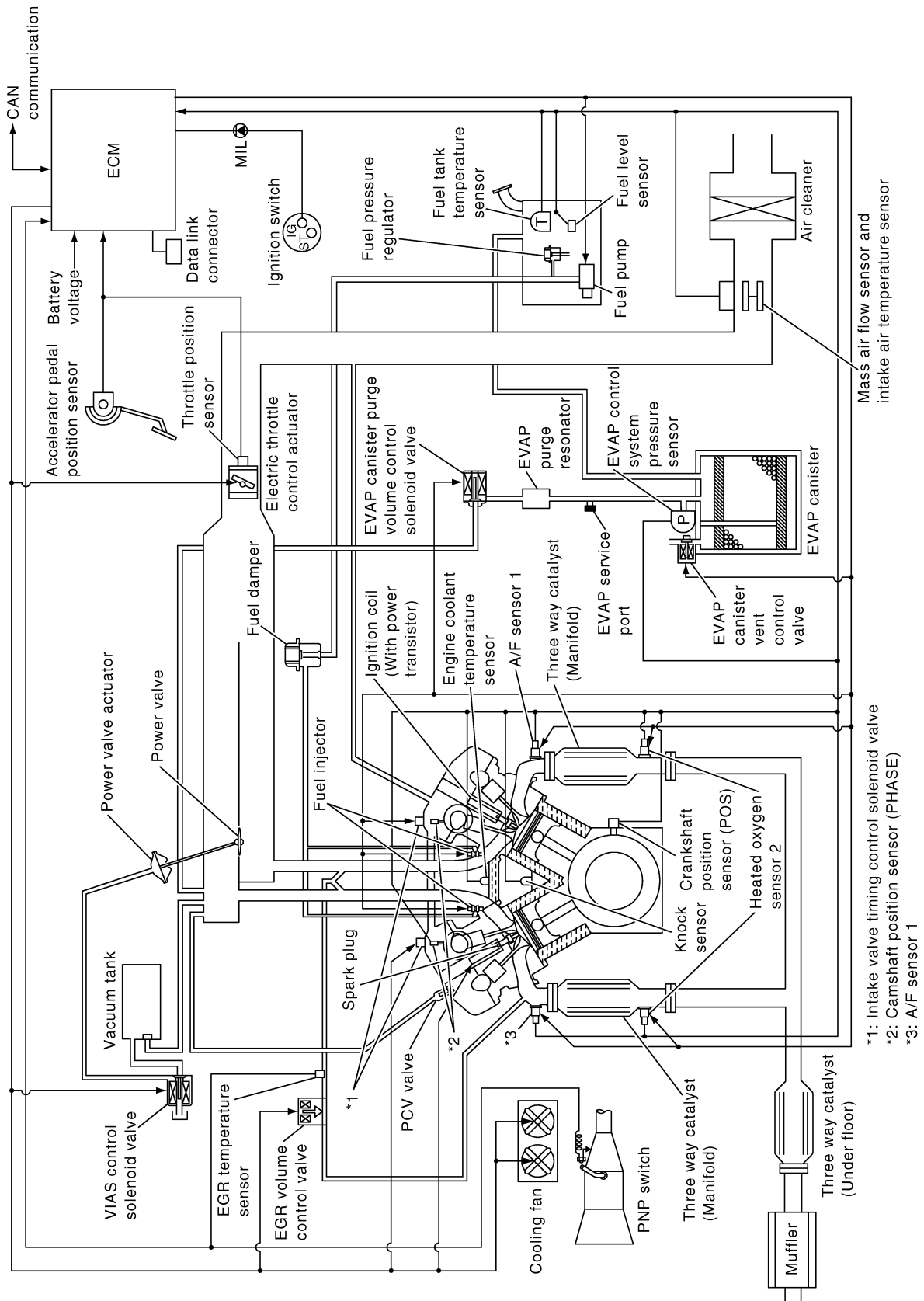

- *1: Intake valve timing control solenoid valve
- *2: Camshaft position sensor (PHASE)
- *3: A/F sensor 1

ENGINE CONTROL SYSTEM

Multipoint Fuel Injection (MFI) System INPUT/OUTPUT SIGNAL CHART

UBS00P00

Sensor	Input Signal to ECM	ECM function	Actuator
Crankshaft position sensor (POS)	Engine speed* ³	Fuel injection & mixture ratio control	Fuel injector
Camshaft position sensor (PHASE)	Piston position		
Mass air flow sensor	Amount of intake air		
Engine coolant temperature sensor	Engine coolant temperature		
Air fuel ratio (A/F) sensor 1	Density of oxygen in exhaust gas		
Throttle position sensor	Throttle position		
Accelerator pedal position sensor	Accelerator pedal position		
Park/neutral position (PNP) switch	Gear position		
Knock sensor	Engine knocking condition		
Battery	Battery voltage* ³		
Power steering pressure sensor	Power steering operation		
Heated oxygen sensor 2* ¹	Density of oxygen in exhaust gas		
Air conditioner switch	Air conditioner operation* ²		
Wheel sensor	Vehicle speed* ²		

*1: This sensor is not used to control the engine system. This is used only for the on board diagnosis.

*2: This signal is sent to the ECM through CAN communication line.

*3: ECM determines the start signal status by the signals of engine speed and battery voltage.

SYSTEM DESCRIPTION

The amount of fuel injected from the fuel injector is determined by the ECM. The ECM controls the length of time the valve remains open (injection pulse duration). The amount of fuel injected is a program value in the ECM memory. The program value is preset by engine operating conditions. These conditions are determined by input signals (for engine speed and intake air) from both the crankshaft position sensor and the mass air flow sensor.

VARIOUS FUEL INJECTION INCREASE/DECREASE COMPENSATION

In addition, the amount of fuel injected is compensated to improve engine performance under various operating conditions as listed below.

<Fuel increase>

- During warm-up
- When starting the engine
- During acceleration
- Hot-engine operation
- When shift lever is changed from N to D
- High-load, high-speed operation

<Fuel decrease>

- During deceleration
- During high engine speed operation

ENGINE CONTROL SYSTEM

MIXTURE RATIO FEEDBACK CONTROL (CLOSED LOOP CONTROL)

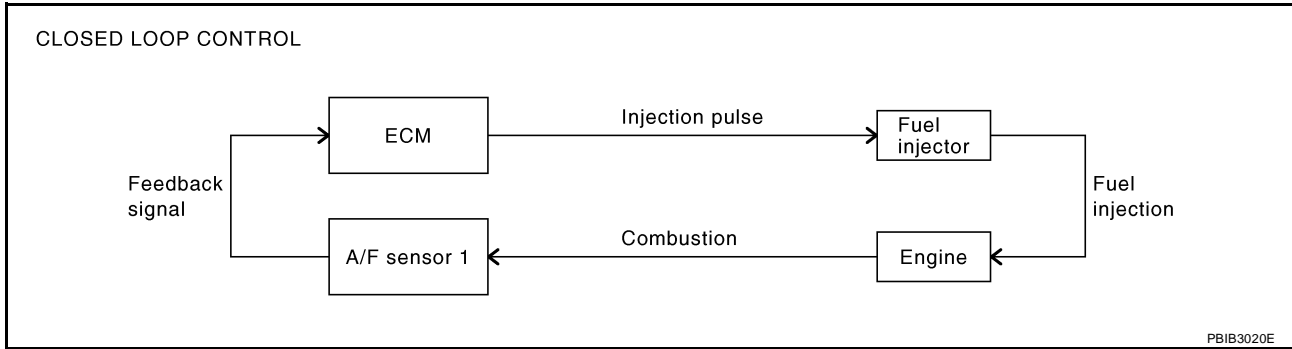

The mixture ratio feedback system provides the best air-fuel mixture ratio for driveability and emission control. The three way catalyst (Manifold) can then better reduce CO, HC and NOx emissions. This system uses air fuel ratio (A/F) sensor 1 in the exhaust manifold to monitor whether the engine operation is rich or lean. The ECM adjusts the injection pulse width according to the sensor voltage signal. For more information about air fuel ratio (A/F) sensor 1, refer to [EC-250, "DTC P0131, P0151 A/F SENSOR 1"](#). This maintains the mixture ratio within the range of stoichiometric (ideal air-fuel mixture).

This stage is referred to as the closed loop control condition.

Heated oxygen sensor 2 is located downstream of the three way catalyst (Manifold). Even if the switching characteristics of air fuel ratio (A/F) sensor 1 shift, the air-fuel ratio is controlled to stoichiometric by the signal from heated oxygen sensor 2.

Open Loop Control

The open loop system condition refers to when the ECM detects any of the following conditions. Feedback control stops in order to maintain stabilized fuel combustion.

- Deceleration and acceleration
- High-load, high-speed operation
- Malfunction of A/F sensor 1 or its circuit
- Insufficient activation of A/F sensor 1 at low engine coolant temperature
- High engine coolant temperature
- During warm-up
- After shifting from N to D
- When starting the engine

MIXTURE RATIO SELF-LEARNING CONTROL

The mixture ratio feedback control system monitors the mixture ratio signal transmitted from A/F sensor 1. This feedback signal is then sent to the ECM. The ECM controls the basic mixture ratio as close to the theoretical mixture ratio as possible. However, the basic mixture ratio is not necessarily controlled as originally designed. Both manufacturing differences (i.e., mass air flow sensor hot wire) and characteristic changes during operation (i.e., fuel injector clogging) directly affect mixture ratio.

Accordingly, the difference between the basic and theoretical mixture ratios is monitored in this system. This is then computed in terms of "injection pulse duration" to automatically compensate for the difference between the two ratios.

"Fuel trim" refers to the feedback compensation value compared against the basic injection duration. Fuel trim includes short term fuel trim and long term fuel trim.

"Short term fuel trim" is the short-term fuel compensation used to maintain the mixture ratio at its theoretical value. The signal from A/F sensor 1 indicates whether the mixture ratio is RICH or LEAN compared to the theoretical value. The signal then triggers a reduction in fuel volume if the mixture ratio is rich, and an increase in fuel volume if it is lean.

"Long term fuel trim" is overall fuel compensation carried out long-term to compensate for continual deviation of the short term fuel trim from the central value. Such deviation will occur due to individual engine differences, wear over time and changes in the usage environment.

ENGINE CONTROL SYSTEM

FUEL INJECTION TIMING

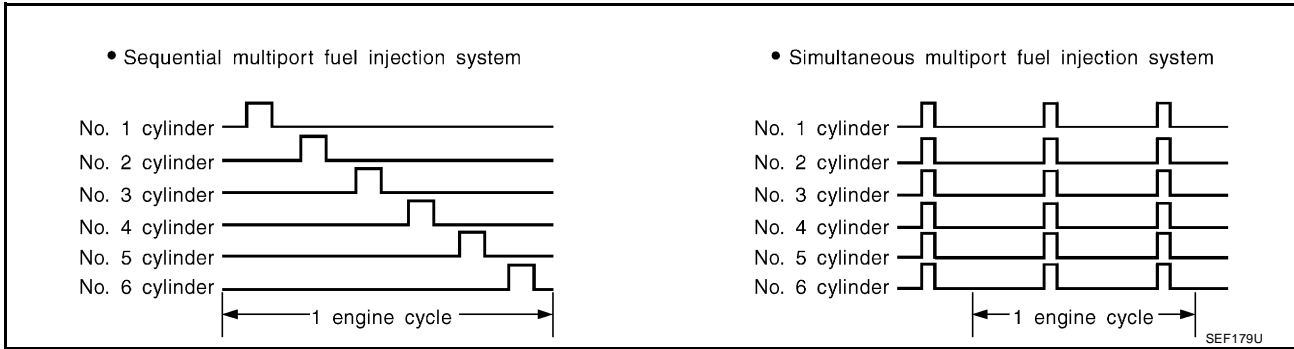

Two types of systems are used.

Sequential Multiport Fuel Injection System

Fuel is injected into each cylinder during each engine cycle according to the firing order. This system is used when the engine is running.

Simultaneous Multiport Fuel Injection System

Fuel is injected simultaneously into all six cylinders twice each engine cycle. In other words, pulse signals of the same width are simultaneously transmitted from the ECM.

The six fuel injectors will then receive the signals two times for each engine cycle.

This system is used when the engine is being started and/or if the fail-safe system (CPU) is operating.

FUEL SHUT-OFF

Fuel to each cylinder is cut off during deceleration, operation of the engine at excessively high speeds or operation of the vehicle at excessively high speeds.

Electronic Ignition (EI) System INPUT/OUTPUT SIGNAL CHART

UBS00P0R

Sensor	Input Signal to ECM	ECM function	Actuator
Crankshaft position sensor (POS)	Engine speed*2 Piston position	Ignition timing control	Power transistor
Camshaft position sensor (PHASE)			
Mass air flow sensor	Amount of intake air		
Engine coolant temperature sensor	Engine coolant temperature		
Throttle position sensor	Throttle position		
Accelerator pedal position sensor	Accelerator pedal position		
Knock sensor	Engine knocking		
Park/neutral position (PNP) switch	Gear position		
Battery	Battery voltage*2		
Wheel sensor	Vehicle speed*1		

*1: This signal is sent to the ECM through CAN communication line.

*2: ECM determines the start signal status by the signals of engine speed and battery voltage.

SYSTEM DESCRIPTION

Firing order: 1 - 2 - 3 - 4 - 5 - 6

The ignition timing is controlled by the ECM to maintain the best air-fuel ratio for every running condition of the engine. The ignition timing data is stored in the ECM.

The ECM receives information such as the injection pulse width and camshaft position sensor (PHASE) signal. Computing this information, ignition signals are transmitted to the power transistor.

During the following conditions, the ignition timing is revised by the ECM according to the other data stored in the ECM.

- At starting
- During warm-up
- At idle
- At low battery voltage

ENGINE CONTROL SYSTEM

- During acceleration

The knock sensor retard system is designed only for emergencies. The basic ignition timing is programmed within the anti-knocking zone, if recommended fuel is used under dry conditions. The retard system does not operate under normal driving conditions. If engine knocking occurs, the knock sensor monitors the condition. The signal is transmitted to the ECM. The ECM retards the ignition timing to eliminate the knocking condition.

Fuel Cut Control (at No Load and High Engine Speed) INPUT/OUTPUT SIGNAL CHART

UBS00POS

Sensor	Input Signal to ECM	ECM function	Actuator
Park/neutral position (PNP) switch	Neutral position	Fuel cut control	Fuel injector
Accelerator pedal position sensor	Accelerator pedal position		
Engine coolant temperature sensor	Engine coolant temperature		
Crankshaft position sensor (POS) Camshaft position sensor (PHASE)	Engine speed		
Wheel sensor	Vehicle speed*		

*: Signal is sent to the ECM through CAN communication line.

SYSTEM DESCRIPTION

If the engine speed is above 1,800 rpm under no load (for example, the shift position is neutral and engine speed is over 1,800 rpm) fuel will be cut off after some time. The exact time when the fuel is cut off varies based on engine speed.

Fuel cut will be operated until the engine speed reaches 1,500 rpm, then fuel cut will be cancelled.

NOTE:

This function is different from deceleration control listed under Multiport Fuel Injection (MFI) System, [EC-24](#).

AIR CONDITIONING CUT CONTROL

AIR CONDITIONING CUT CONTROL

PF2:23710

Input/Output Signal Chart

UBS00P0T

Sensor	Input Signal to ECM	ECM function	Actuator
Air conditioner switch	Air conditioner ON signal* ¹	Air conditioner cut control	Air conditioner relay
Accelerator pedal position sensor	Accelerator pedal position		
Crankshaft position sensor (POS) Camshaft position sensor (PHASE)	Engine speed* ²		
Engine coolant temperature sensor	Engine coolant temperature		
Battery	Battery voltage* ²		
Refrigerant pressure sensor	Refrigerant pressure		
Power steering pressure sensor	Power steering operation		
Wheel sensor	Vehicle speed* ¹		

*1: This signal is sent to the ECM through CAN communication line.

*2: ECM determines the start signal status by the signals of engine speed and battery voltage.

System Description

UBS00P0U

This system improves engine operation when the air conditioner is used. Under the following conditions, the air conditioner is turned OFF.

- When the accelerator pedal is fully depressed.
- When cranking the engine.
- At high engine speeds.
- When the engine coolant temperature becomes excessively high.
- When operating power steering during low engine speed or low vehicle speed.
- When engine speed is excessively low.
- When refrigerant pressure is excessively low or high.

AUTOMATIC SPEED CONTROL DEVICE (ASCD)

AUTOMATIC SPEED CONTROL DEVICE (ASCD)

PF:18930

System Description INPUT/OUTPUT SIGNAL CHART

UBS00P0V

Sensor	Input signal to ECM	ECM function	Actuator
ASCD brake switch	Brake pedal operation	ASCD vehicle speed control	Electric throttle control actuator
Stop lamp switch	Brake pedal operation		
ASCD steering switch	ASCD steering switch operation		
Park/Neutral position (PNP) switch	Gear position		
Combination meter	Vehicle speed*		
TCM	Powertrain revolution*		

*: This signal is sent to the ECM through CAN communication line.

BASIC ASCD SYSTEM

Refer to Owner's Manual for ASCD operating instructions.

Automatic Speed Control Device (ASCD) allows a driver to keep vehicle at predetermined constant speed without depressing accelerator pedal. Driver can set vehicle speed in advance between approximately 40 km/h (25 MPH) and 144 km/h (89 MPH).

ECM controls throttle angle of electric throttle control actuator to regulate engine speed.

Operation status of ASCD is indicated by CRUISE indicator and SET indicator in combination meter. If any malfunction occurs in ASCD system, it automatically deactivates control.

NOTE:

Always drive vehicle in safe manner according to traffic conditions and obey all traffic laws.

SET OPERATION

Press MAIN switch. (The CRUISE indicator in combination meter illuminates.)

When vehicle speed reaches a desired speed between approximately 40 km/h (25 MPH) and 144 km/h (89 MPH), press SET/COAST switch. (Then SET indicator in combination meter illuminates.)

ACCELERATOR OPERATION

If the RESUME/ACCELERATE switch is depressed during cruise control driving, increase the vehicle speed until the switch is released or vehicle speed reaches maximum speed controlled by the system.

And then ASCD will keep the new set speed.

CANCEL OPERATION

When any of following conditions exist, cruise operation will be canceled.

- CANCEL switch is depressed
- More than 2 switches at ASCD steering switch are depressed at the same time (Set speed will be cleared)
- Brake pedal is depressed
- Shift lever is changed to N, P, R position
- Vehicle speed decreased to 13 km/h (8 MPH) lower than the set speed
- VDC/TCS system is operated

When the ECM detects any of the following conditions, the ECM will cancel the cruise operation and inform the driver by blinking indicator lamp.

- Engine coolant temperature is slightly higher than the normal operating temperature, CRUISE lamp may blink slowly.
When the engine coolant temperature decreases to the normal operating temperature, CRUISE lamp will stop blinking and the cruise operation will be able to work by depressing SET/COAST switch or RESUME/ACCELERATE switch.
- Malfunction for some self-diagnoses regarding ASCD control: SET lamp will blink quickly.

If MAIN switch is turned to OFF during ASCD is activated, all of ASCD operations will be canceled and vehicle speed memory will be erased.

AUTOMATIC SPEED CONTROL DEVICE (ASCD)

COAST OPERATION

When the SET/COAST switch is depressed during cruise control driving, decrease vehicle set speed until the switch is released. And then ASCD will keep the new set speed.

RESUME OPERATION

When the RESUME/ACCELERATE switch is depressed after cancel operation other than depressing MAIN switch is performed, vehicle speed will return to last set speed. To resume vehicle set speed, vehicle condition must meet following conditions.

- Brake pedal is released
- A/T shift lever is in other than P and N positions
- Vehicle speed is greater than 40 km/h (25 MPH) and less than 144 km/h (89 MPH)

Component Description

UBS00P0W

ASCD STEERING SWITCH

Refer to [EC-568](#) .

ASCD BRAKE SWITCH

Refer to [EC-576](#) and [EC-661](#) .

STOP LAMP SWITCH

Refer to [EC-576](#) , [EC-591](#) and [EC-661](#) .

ELECTRIC THROTTLE CONTROL ACTUATOR

Refer to [EC-596](#) , [EC-602](#) , [EC-609](#) and [EC-615](#) .

ASCD INDICATOR

Refer to [EC-668](#) .

CAN COMMUNICATION

CAN COMMUNICATION

PFP:23710

System Description

UBS00P0X

CAN (Controller Area Network) is a serial communication line for real time application. It is an on-vehicle multiplex communication line with high data communication speed and excellent error detection ability. Many electronic control units are equipped onto a vehicle, and each control unit shares information and links with other control units during operation (not independent). In CAN communication, control units are connected with 2 communication lines (CAN H line, CAN L line) allowing a high rate of information transmission with less wiring. Each control unit transmits/receives data but selectively reads required data only.

Refer to [LAN-49, "CAN System Specification Chart"](#) , about CAN communication for detail.

A

EC

C

D

E

F

G

H

I

J

K

L

M

EVAPORATIVE EMISSION SYSTEM

EVAPORATIVE EMISSION SYSTEM

PFP:14950

Description SYSTEM DESCRIPTION

UBS00P0Y

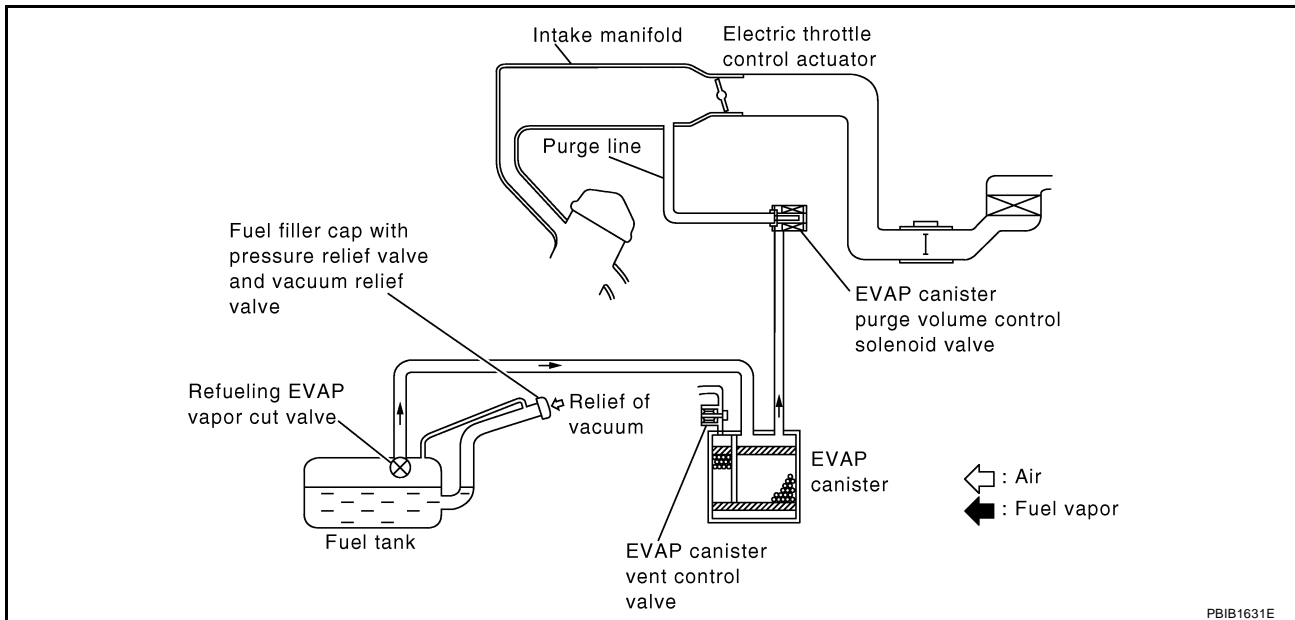

The evaporative emission system is used to reduce hydrocarbons emitted into the atmosphere from the fuel system. This reduction of hydrocarbons is accomplished by activated charcoals in the EVAP canister. The fuel vapor in the sealed fuel tank is led into the EVAP canister which contains activated carbon and the vapor is stored there when the engine is not operating or when refueling to the fuel tank. The vapor in the EVAP canister is purged by the air through the purge line to the intake manifold when the engine is operating. EVAP canister purge volume control solenoid valve is controlled by ECM. When the engine operates, the flow rate of vapor controlled by EVAP canister purge volume control solenoid valve is proportionally regulated as the air flow increases. EVAP canister purge volume control solenoid valve also shuts off the vapor purge line during decelerating and idling.

EVAPORATIVE EMISSION SYSTEM

EVAPORATIVE EMISSION LINE DRAWING

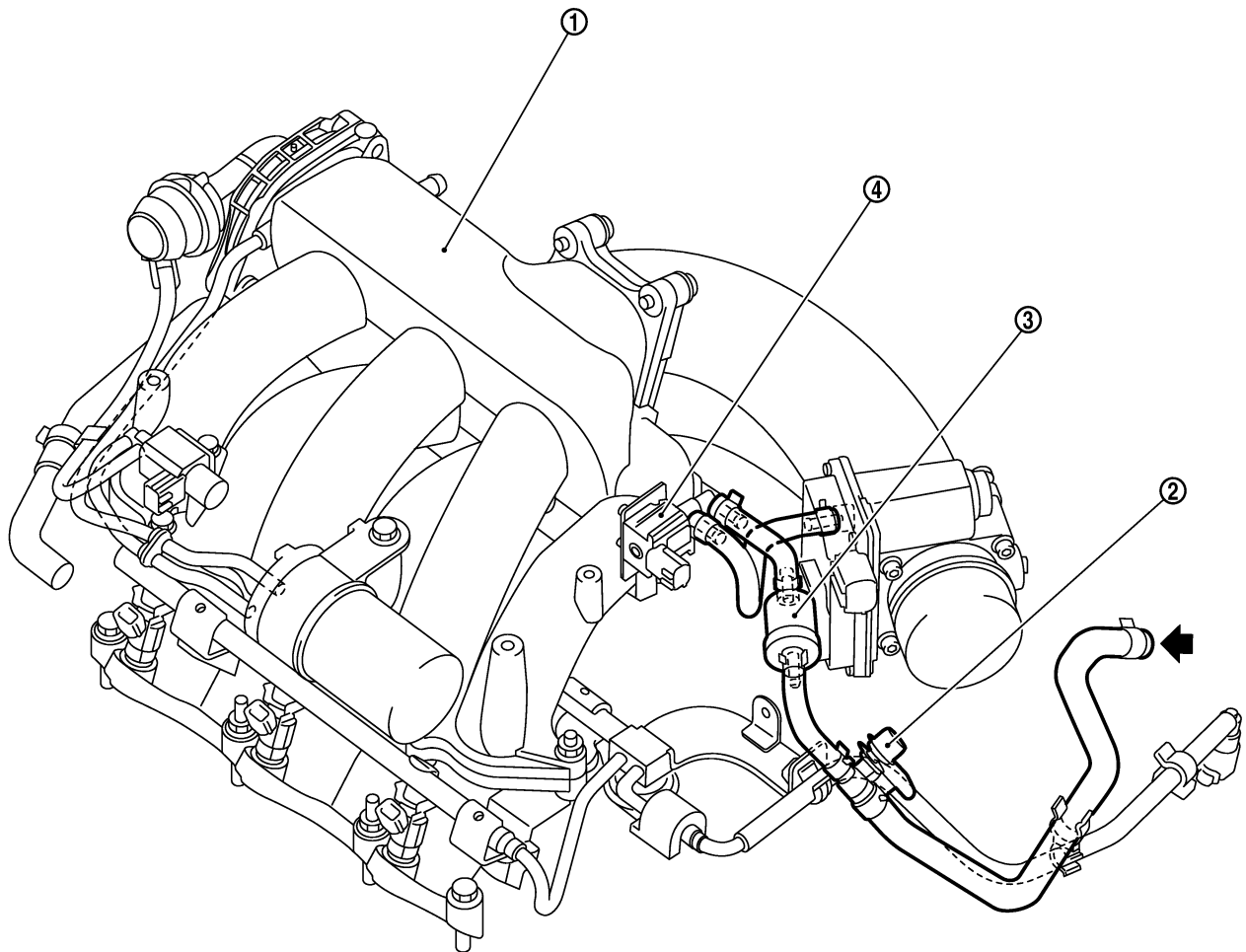

← From next page

- | | | |
|--|----------------------|-------------------------|
| 1. Intake manifold collector | 2. EVAP service port | 3. EVAP purge resonator |
| 4. EVAP canister purge volume control solenoid valve | | |

NOTE:

Do not use soapy water or any type of solvent while installing vacuum hose or purge hoses.

PBIB3073E

A
EC
C
D
E
F
G
H
I
J
K
L
M

EVAPORATIVE EMISSION SYSTEM

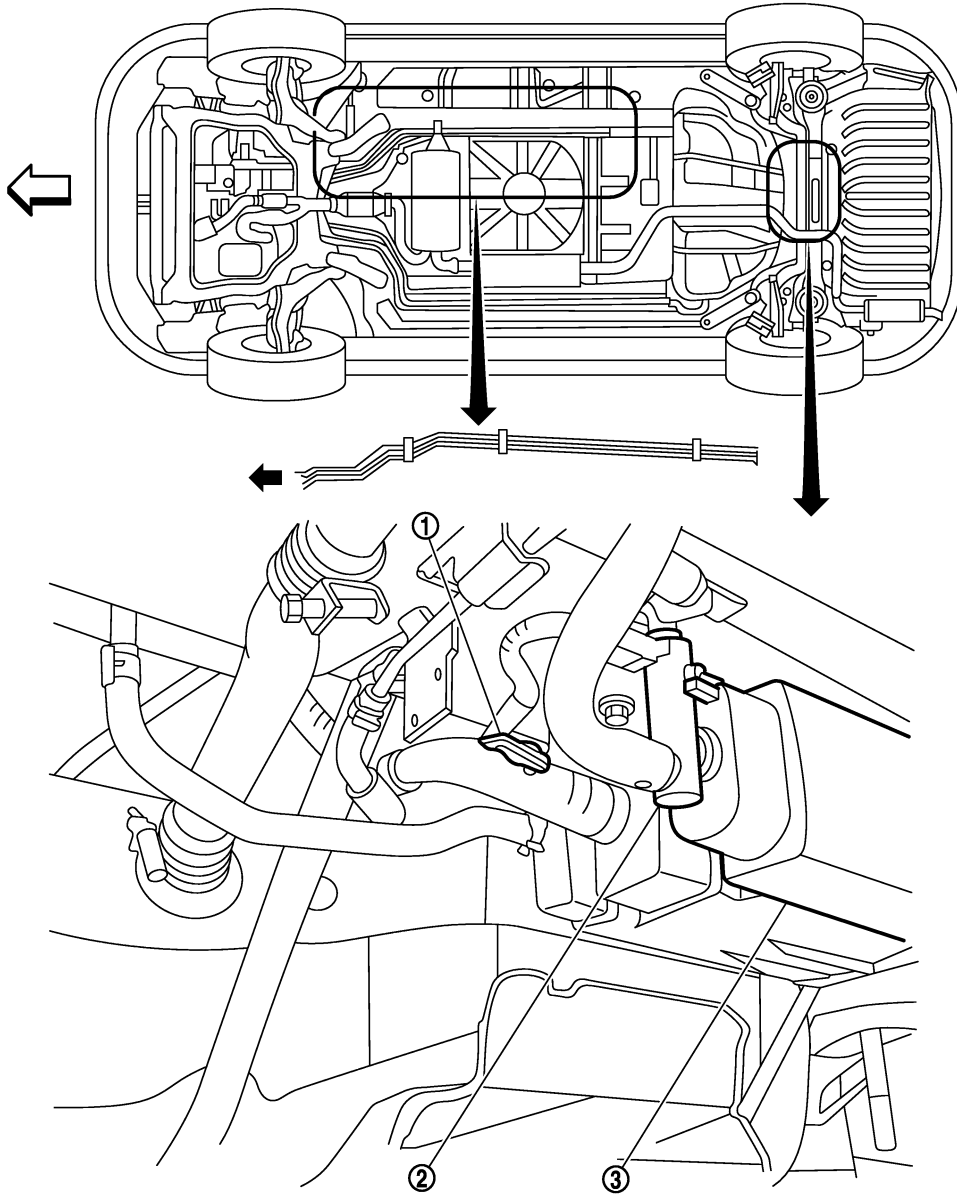

↔ Vehicle front

← To previous page

1. EVAP control system pressure sensor

2. EVAP canister vent control valve

3. EVAP canister

PBIB3069E

EVAPORATIVE EMISSION SYSTEM

UBS00P0Z

Component Inspection EVAP CANISTER

Check EVAP canister as follows:

1. Block port **B** .
2. Blow air into port **A** and check that it flows freely out of port **C** .
3. Release blocked port **B** .
4. Apply vacuum pressure to port **B** and check that vacuum pressure exists at the ports **A** and **C** .
5. Block port **A** and **B** .
6. Apply pressure to port **C** and check that there is no leakage.

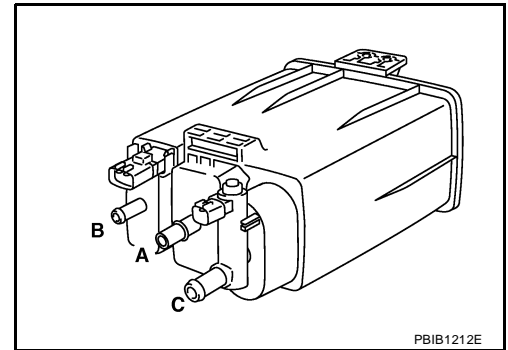

FUEL TANK VACUUM RELIEF VALVE (BUILT INTO FUEL FILLER CAP)

1. Wipe clean valve housing.

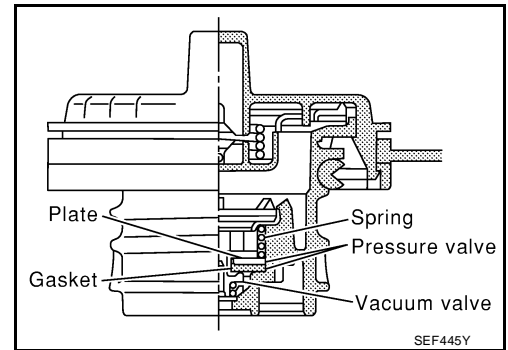

2. Check valve opening pressure and vacuum.

Pressure: 15.3 - 20.0 kPa (0.156 - 0.204 kg/cm² , 2.22 - 2.90 psi)

Vacuum: -6.0 to -3.3 kPa (-0.061 to -0.034 kg/cm² , -0.87 to -0.48 psi)

3. If out of specification, replace fuel filler cap as an assembly.

CAUTION:

Use only a genuine fuel filler cap as a replacement. If an incorrect fuel filler cap is used, the MIL may come on.

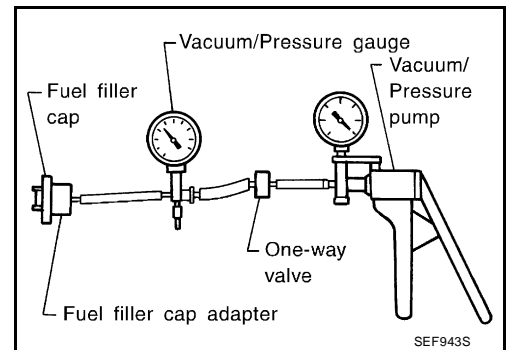

EVAP CANISTER PURGE VOLUME CONTROL SOLENOID VALVE

Refer to [EC-446](#) .

FUEL TANK TEMPERATURE SENSOR

Refer to [EC-351](#) .

EVAP CANISTER VENT CONTROL VALVE

Refer to [EC-459](#) .

EVAP CONTROL SYSTEM PRESSURE SENSOR

Refer to [EC-471](#) .

EVAPORATIVE EMISSION SYSTEM

EVAP SERVICE PORT

Positive pressure is delivered to the EVAP system through the EVAP service port. If fuel vapor leakage in the EVAP system occurs, use a leak detector to locate the leak.

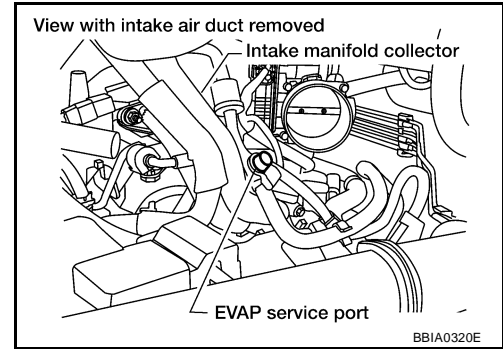

Removal and Installation EVAP CANISTER

UBS00P10

Tighten EVAP canister as shown in the figure.

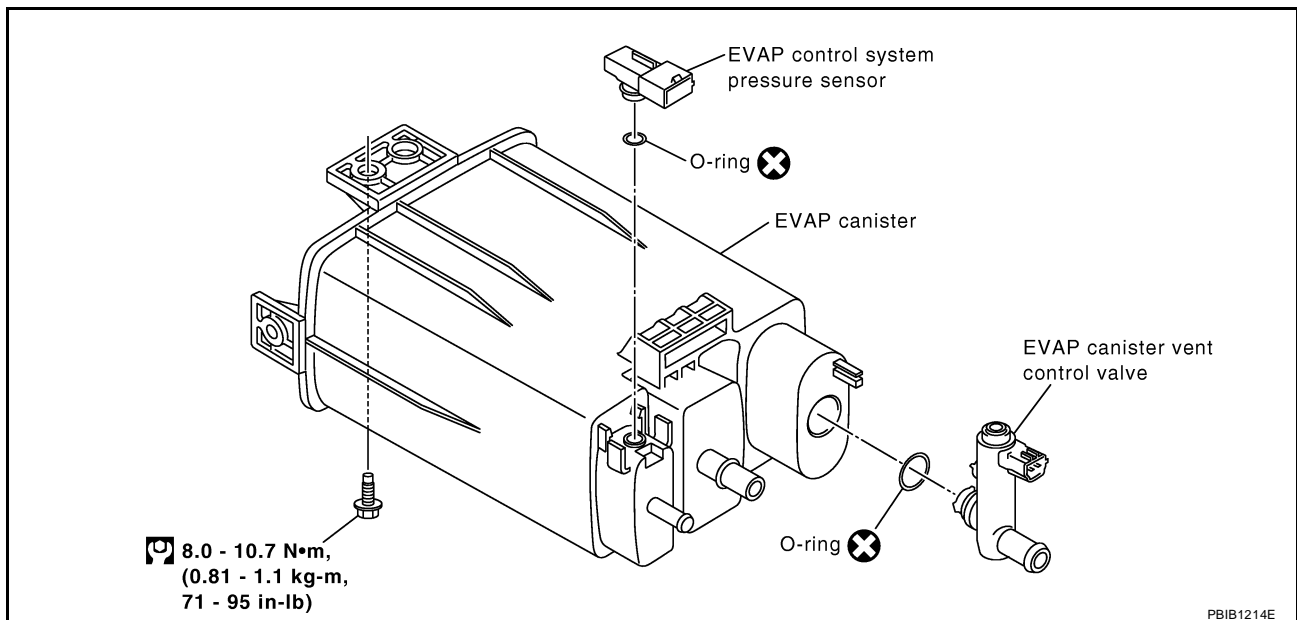

EVAP CANISTER VENT CONTROL VALVE

1. Turn EVAP canister vent control valve counterclockwise.
2. Remove the EVAP canister vent control valve.

Always replace O-ring with a new one.

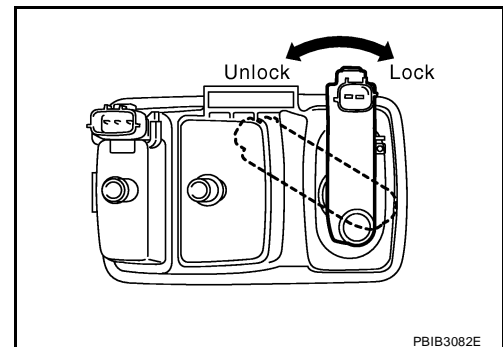

How to Detect Fuel Vapor Leakage

UBS00P11

CAUTION:

- Never use compressed air or a high pressure pump.
- Do not exceed 4.12 kPa (0.042 kg/cm², 0.6 psi) of pressure in EVAP system.

NOTE:

- Do not start engine.
- Improper installation of EVAP service port adapter to the EVAP service port may cause a leak.

EVAPORATIVE EMISSION SYSTEM

Ⓟ WITH CONSULT-II

1. Attach the EVAP service port adapter securely to the EVAP service port.
2. Also attach the pressure pump and hose to the EVAP service port adapter.
3. Turn ignition switch ON.
4. Select the "EVAP SYSTEM CLOSE" of "WORK SUPPORT MODE" with CONSULT-II.
5. Touch "START". A bar graph (Pressure indicating display) will appear on the screen.

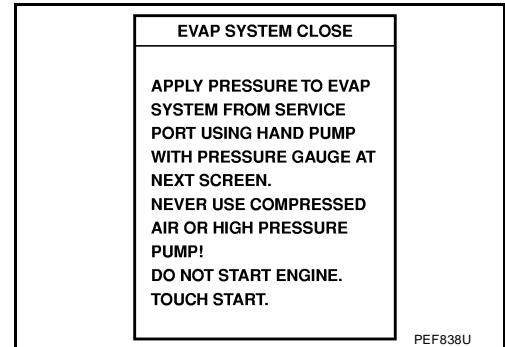

6. Apply positive pressure to the EVAP system until the pressure indicator reaches the middle of the bar graph.
7. Remove EVAP service port adapter and hose with pressure pump.

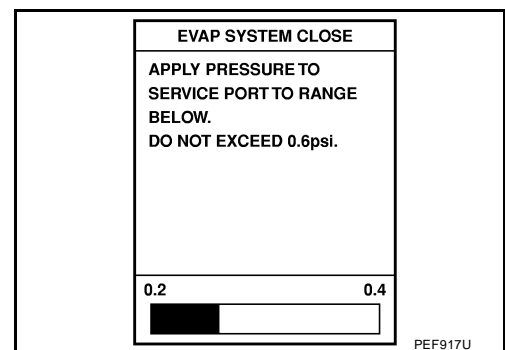

8. Locate the leak using a leak detector. Refer to [EC-33, "EVAPORATIVE EMISSION LINE DRAWING"](#).

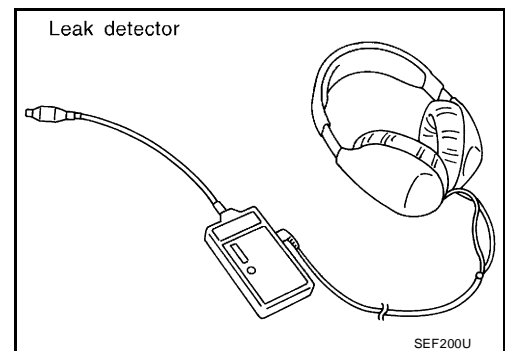

ⓧ WITHOUT CONSULT-II

1. Attach the EVAP service port adapter securely to the EVAP service port.
2. Also attach the pressure pump with pressure gauge to the EVAP service port adapter.

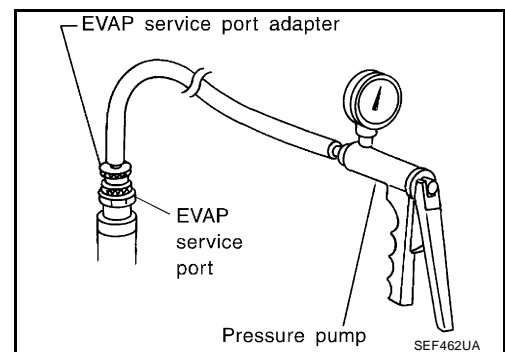

EVAPORATIVE EMISSION SYSTEM

3. Apply battery voltage between the terminals of EVAP canister vent control valve to make a closed EVAP system.

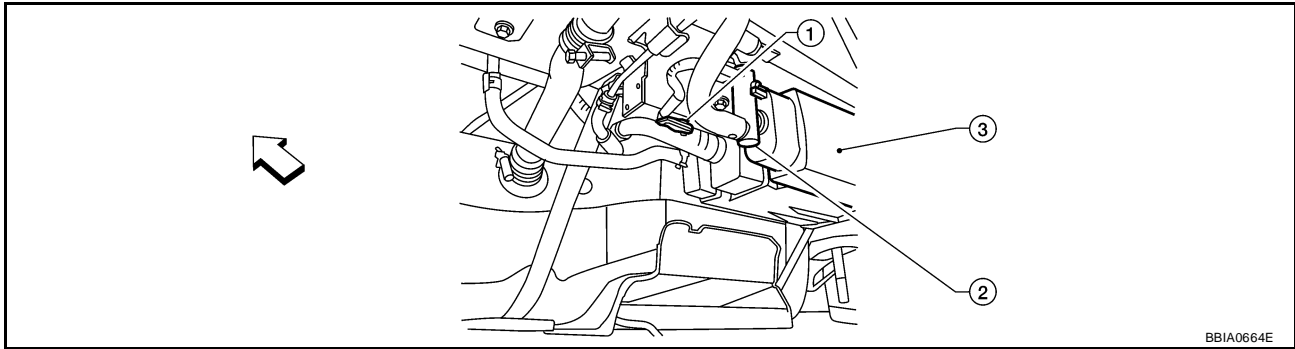

↔ Vehicle front

1. EVAP control system pressure sensor
 2. EVAP canister vent control valve
 3. EVAP canister
4. To locate the leak, deliver positive pressure to the EVAP system until pressure gauge points reach 1.38 to 2.76 kPa (0.014 to 0.028 kg/cm² , 0.2 to 0.4 psi).
 5. Remove EVAP service port adapter and hose with pressure pump.
 6. Locate the leak using a leak detector. Refer to [EC-33. "EVAPORATIVE EMISSION LINE DRAWING"](#) .

ON BOARD REFUELING VAPOR RECOVERY (ORVR)

ON BOARD REFUELING VAPOR RECOVERY (ORVR)

PFP:00032

System Description

UBS00P12

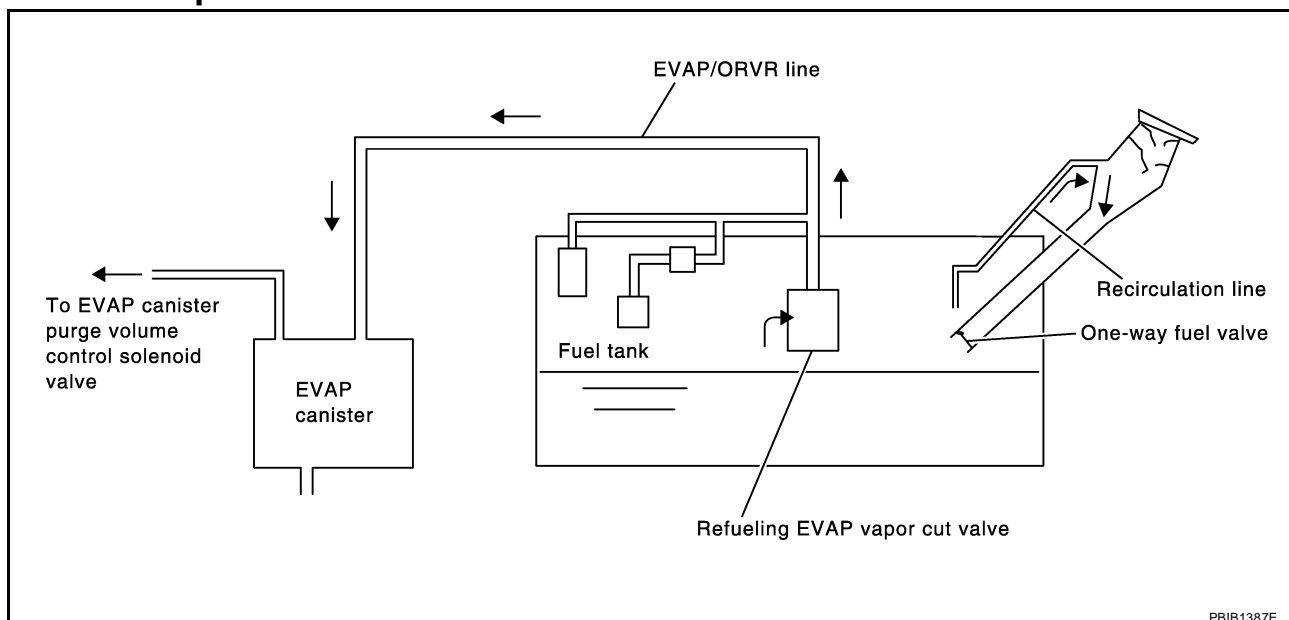

From the beginning of refueling, the air and vapor inside the fuel tank go through refueling EVAP vapor cut valve and EVAP/ORVR line to the EVAP canister. The vapor is absorbed by the EVAP canister and the air is released to the atmosphere.

When the refueling has reached the full level of the fuel tank, the refueling EVAP vapor cut valve is closed and refueling is stopped because of auto shut-off. The vapor which was absorbed by the EVAP canister is purged during driving.

WARNING:

When conducting inspections below, be sure to observe the following:

- Put a "CAUTION: FLAMMABLE" sign in workshop.
- Do not smoke while servicing fuel system. Keep open flames and sparks away from work area.
- Be sure to furnish the workshop with a CO₂ fire extinguisher.

CAUTION:

Before removing fuel line parts, carry out the following procedures:

- Put drained fuel in an explosion-proof container and put lid on securely.
- Release fuel pressure from fuel line. Refer to [EC-82, "FUEL PRESSURE RELEASE"](#).
- Disconnect battery ground cable.
- Always replace O-ring when the fuel gauge retainer is removed.
- Do not kink or twist hose and tube when they are installed.
- Do not tighten hose and clamps excessively to avoid damaging hoses.
- After installation, run engine and check for fuel leaks at connection.
- Do not attempt to top off the fuel tank after the fuel pump nozzle shuts off automatically. Continued refueling may cause fuel overflow, resulting in fuel spray and possibly a fire.

ON BOARD REFUELING VAPOR RECOVERY (ORVR)

UBS00P13

Diagnostic Procedure

SYMPTOM: FUEL ODOR FROM EVAP CANISTER IS STRONG.

1. CHECK EVAP CANISTER

1. Remove EVAP canister with EVAP canister vent control valve and EVAP control system pressure sensor attached.
2. Weigh the EVAP canister with EVAP canister vent control valve and EVAP control system pressure sensor attached.
The weight should be less than 2.1 kg (4.6 lb).

OK or NG

- OK >> GO TO 2.
NG >> GO TO 3.

2. CHECK IF EVAP CANISTER SATURATED WITH WATER

Does water drain from the EVAP canister?

Yes or No

- Yes >> GO TO 3.
No >> GO TO 5.

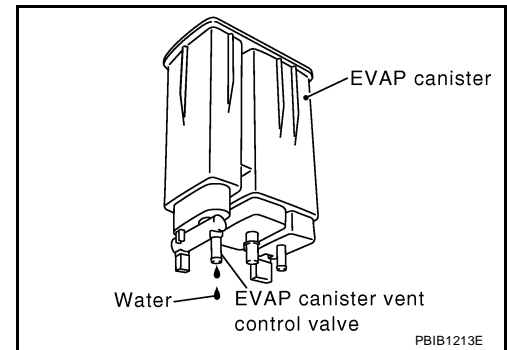

3. REPLACE EVAP CANISTER

Replace EVAP canister with a new one.

>> GO TO 4.

4. DETECT MALFUNCTIONING PART

Check the EVAP hose between EVAP canister and vehicle frame for clogging or poor connection.

>> Repair or replace EVAP hose.

5. CHECK REFUELING EVAP VAPOR CUT VALVE

Refer to [EC-43, "Component Inspection"](#) .

OK or NG

- OK >> **INSPECTION END**
NG >> Replace refueling EVAP vapor cut valve with fuel tank.

ON BOARD REFUELING VAPOR RECOVERY (ORVR)

SYMPTOM: CANNOT REFUEL/FUEL ODOR FROM THE FUEL FILLER OPENING IS STRONG WHILE REFUELING.

1. CHECK EVAP CANISTER

1. Remove EVAP canister with EVAP canister vent control valve and EVAP control system pressure sensor attached.
2. Weigh the EVAP canister with EVAP canister vent control valve and EVAP control system pressure sensor attached.

The weight should be less than 2.1 kg (4.6 lb).

OK or NG

- OK >> GO TO 2.
NG >> GO TO 3.

2. CHECK IF EVAP CANISTER SATURATED WITH WATER

Does water drain from the EVAP canister?

Yes or No

- Yes >> GO TO 3.
No >> GO TO 5.

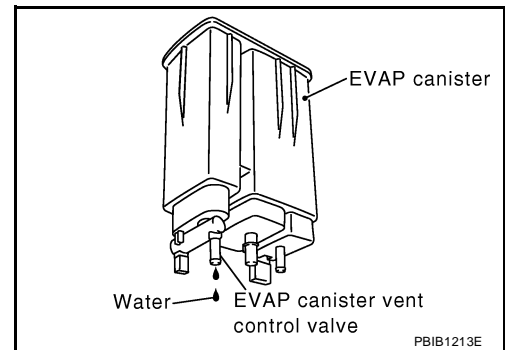

3. REPLACE EVAP CANISTER

Replace EVAP canister with a new one.

>> GO TO 4.

4. DETECT MALFUNCTIONING PART

Check the EVAP hose between EVAP canister and vehicle frame for clogging or poor connection.

>> Repair or replace EVAP hose.

5. CHECK VENT HOSES AND VENT TUBES

Check hoses and tubes between EVAP canister and refueling EVAP vapor cut valve for clogging, kink, looseness and improper connection.

OK or NG

- OK >> GO TO 6.
NG >> Repair or replace hoses and tubes.

6. CHECK FILLER NECK TUBE

Check recirculation line for clogging, dents and cracks.

OK or NG

- OK >> GO TO 7.
NG >> Replace filler neck tube.

ON BOARD REFUELING VAPOR RECOVERY (ORVR)

7. CHECK REFUELING EVAP VAPOR CUT VALVE

Refer to [EC-43, "Component Inspection"](#) .

OK or NG

- OK >> GO TO 8.
- NG >> Replace refueling EVAP vapor cut valve with fuel tank.

8. CHECK FUEL FILLER TUBE

Check filler neck tube and hose connected to the fuel tank for clogging, dents and cracks.

OK or NG

- OK >> GO TO 9.
- NG >> Replace fuel filler tube.

9. CHECK ONE-WAY FUEL VALVE-I

Check one-way valve for clogging.

OK or NG

- OK >> GO TO 10.
- NG >> Repair or replace one-way fuel valve with fuel tank.

10. CHECK ONE-WAY FUEL VALVE-II

1. Make sure that fuel is drained from the tank.
2. Remove fuel filler tube and hose.
3. Check one-way fuel valve for operation as follows.
When a stick is inserted, the valve should open, when removing stick it should close.

Do not drop any material into the tank.

OK or NG

- OK >> **INSPECTION END**
- NG >> Replace fuel filler tube or replace one-way fuel valve with fuel tank.

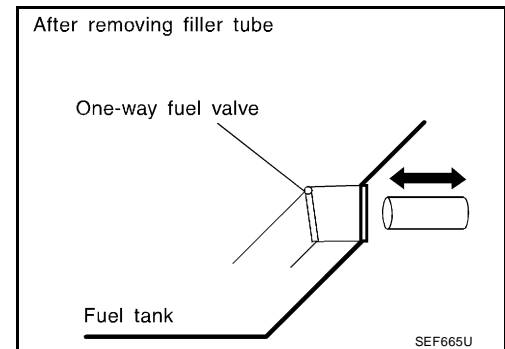

ON BOARD REFUELING VAPOR RECOVERY (ORVR)

UBS00P14

Component Inspection REFUELING EVAP VAPOR CUT VALVE

🔧 With CONSULT-II

1. Remove fuel tank. Refer to [FL-9, "FUEL TANK"](#).
2. Drain fuel from the tank as follows:
 - a. Remove fuel feed hose located on the fuel gauge retainer.
 - b. Connect a spare fuel hose, one side to fuel gauge retainer where the hose was removed and the other side to a fuel container.
 - c. Drain fuel using "FUEL PUMP RELAY" in "ACTIVE TEST" mode with CONSULT-II.
3. Check refueling EVAP vapor cut valve for being stuck to close as follows.
Blow air into the refueling EVAP vapor cut valve (from the end of EVAP/ORVR line hose), and check that the air flows freely into the tank.
4. Check refueling EVAP vapor cut valve for being stuck to open as follows.
 - a. Connect vacuum pump to hose end.
 - b. Remove fuel gauge retainer with fuel gauge unit.
Always replace O-ring with new one.
 - c. Put fuel tank upside down.
 - d. Apply vacuum pressure to hose end [-13.3 kPa (-100 mmHg, -3.94 inHg)] with fuel gauge retainer remaining open and check that the pressure is applicable.

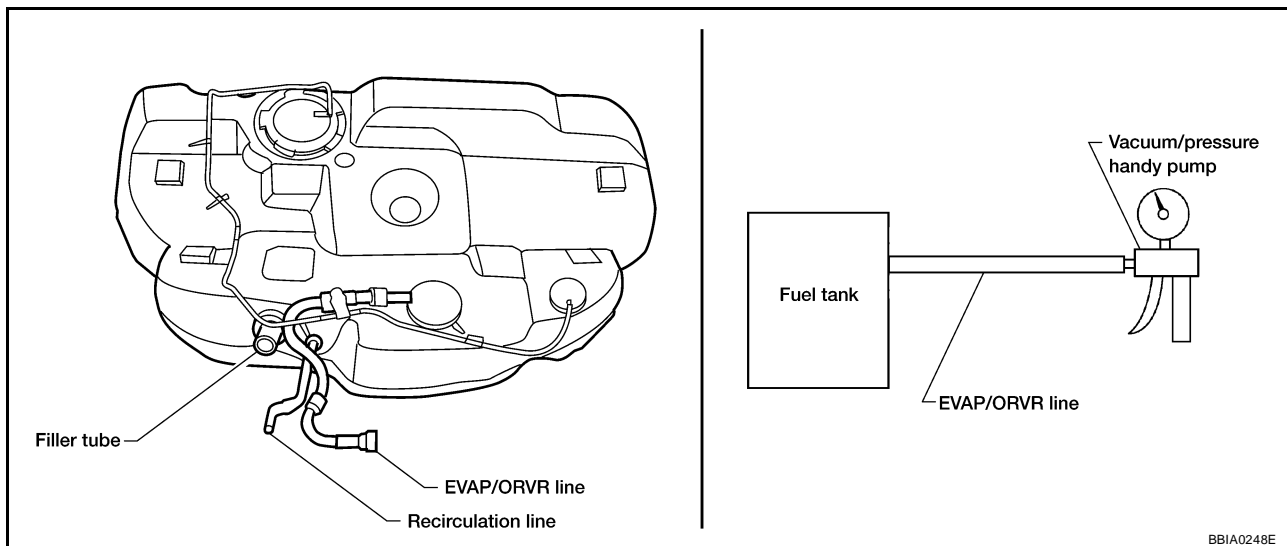

⊗ Without CONSULT-II

1. Remove fuel tank. Refer to [FL-9, "FUEL TANK"](#).
2. Drain fuel from the tank as follows:
 - a. Remove fuel gauge retainer.
 - b. Drain fuel from the tank using a handy pump into a fuel container.
3. Check refueling EVAP vapor cut valve for being stuck to close as follows.
Blow air into the refueling EVAP vapor cut valve (from the end of EVAP/ORVR line hose), and check that the air flows freely into the tank.
4. Check refueling EVAP vapor cut valve for being stuck to open as follows.
 - a. Connect vacuum pump to hose end.
 - b. Remove fuel gauge retainer with fuel gauge unit.
Always replace O-ring with new one.
 - c. Put fuel tank upside down.

ON BOARD REFUELING VAPOR RECOVERY (ORVR)

- d. Apply vacuum pressure to hose end [-13.3 kPa (-100 mmHg, -3.94 inHg)] with fuel gauge retainer remaining open and check that the pressure is applicable.

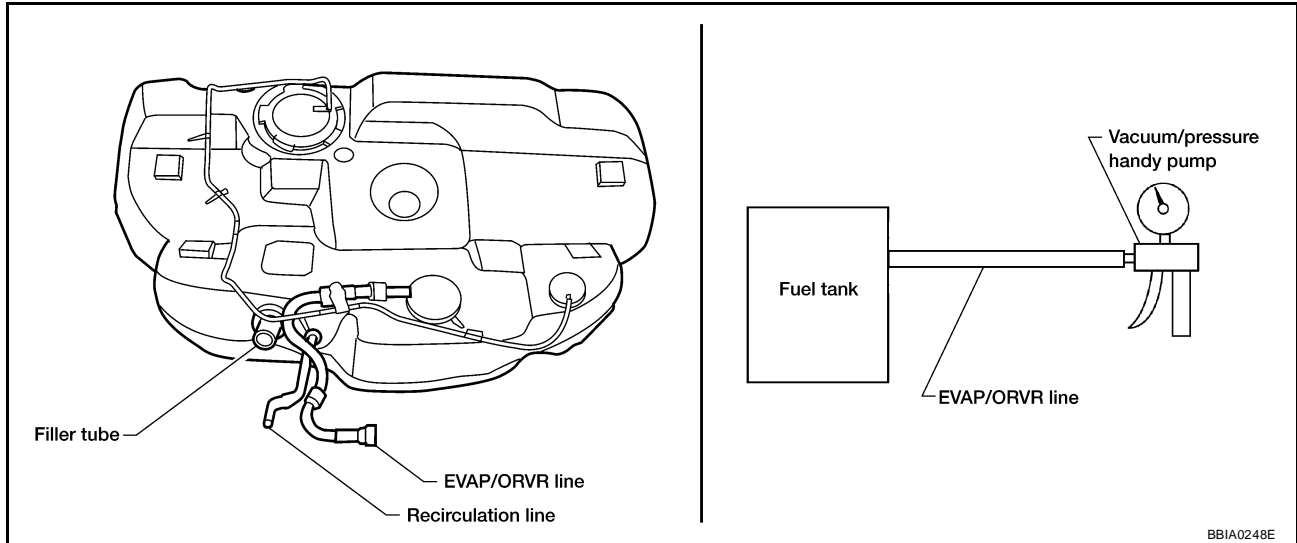

POSITIVE CRANKCASE VENTILATION

POSITIVE CRANKCASE VENTILATION

PFP:11810

UBS00P15

Description SYSTEM DESCRIPTION

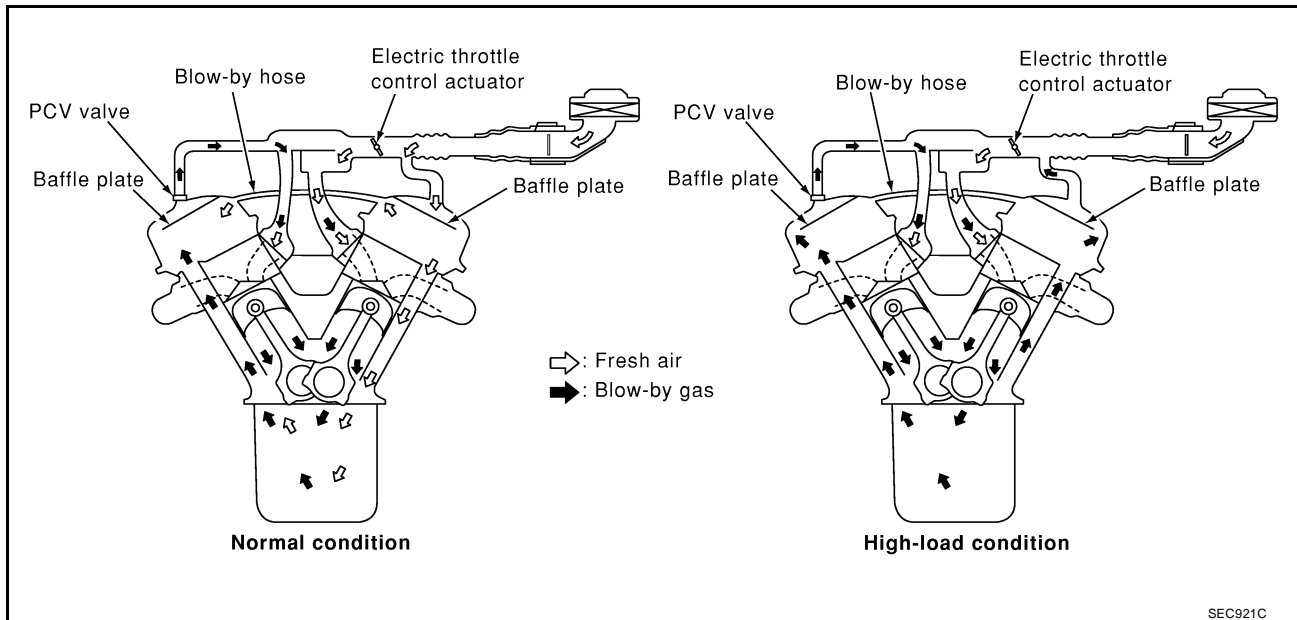

This system returns blow-by gas to the intake manifold.

The positive crankcase ventilation (PCV) valve is provided to conduct crankcase blow-by gas to the intake manifold. During partial throttle operation of the engine, the intake manifold sucks the blow-by gas through the PCV valve. Normally, the capacity of the valve is sufficient to handle any blow-by and a small amount of ventilating air. The ventilating air is then drawn from the air inlet tubes into the crankcase. In this process the air passes through the hose connecting air inlet tubes to rocker cover. Under full-throttle condition, the manifold vacuum is insufficient to draw the blow-by flow through the valve. The flow goes through the hose connection in the reverse direction.

On vehicles with an excessively high blow-by, the valve does not meet the requirement. This is because some of the flow will go through the hose connection to the air inlet tubes under all conditions.

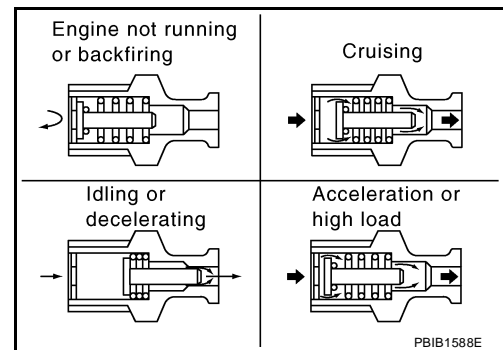

Component Inspection PCV (POSITIVE CRANKCASE VENTILATION) VALVE

UBS00P16

With engine running at idle, remove PCV valve from rocker cover. A properly working valve makes a hissing noise as air passes through it. A strong vacuum should be felt immediately when a finger is placed over valve inlet.

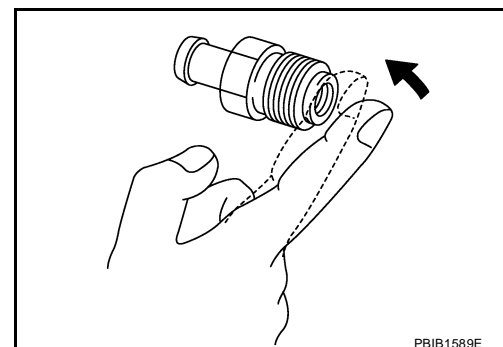

POSITIVE CRANKCASE VENTILATION

PCV VALVE VENTILATION HOSE

1. Check hoses and hose connections for leaks.
2. Disconnect all hoses and clean with compressed air. If any hose cannot be freed of obstructions, replace.

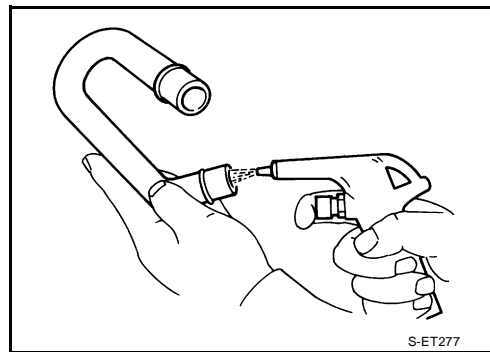

NVIS (NISSAN VEHICLE IMMOBILIZER SYSTEM-NATS)

NVIS (NISSAN VEHICLE IMMOBILIZER SYSTEM-NATS)

PDF:25386

Description

UBS00P17

- If the security indicator lights up with the ignition switch in the ON position or “NATS MALFUNCTION” is displayed on “SELF-DIAG RESULTS” screen, perform self-diagnostic results mode with CONSULT-II using NATS program card. Refer to [BL-203. "NVIS\(NISSAN Vehicle Immobilizer System-NATS\)"](#).
- Confirm no self-diagnostic results of NVIS (NATS) is displayed before touching “ERASE” in “SELF-DIAG RESULTS” mode with CONSULT-II.
- When replacing ECM, initialization of NVIS (NATS) system and registration of all NVIS (NATS) ignition key IDs must be carried out with CONSULT-II using NATS program card. Therefore, be sure to receive all keys from vehicle owner. Regarding the procedures of NVIS (NATS) initialization and all NVIS (NATS) ignition key ID registration, refer to CONSULT-II Operation Manual, IVIS/NVIS.

SELF DIAG RESULTS	
DTC RESULTS	TIME
NATS MALFUNCTION [P1610]	0

SEF543X

A

EC

C

D

E

F

G

H

I

J

K

L

M

ON BOARD DIAGNOSTIC (OBD) SYSTEM

ON BOARD DIAGNOSTIC (OBD) SYSTEM

PF0:00028

Introduction

UBS00P18

The ECM has an on board diagnostic system, which detects malfunctions related to engine sensors or actuators. The ECM also records various emission-related diagnostic information including:

Emission-related diagnostic information	SAE Mode
Diagnostic Trouble Code (DTC)	Service \$03 of SAE J1979
Freeze Frame data	Service \$02 of SAE J1979
System Readiness Test (SRT) code	Service \$01 of SAE J1979
1st Trip Diagnostic Trouble Code (1st Trip DTC)	Service \$07 of SAE J1979
1st Trip Freeze Frame data	
Test values and Test limits	Service \$06 of SAE J1979
Calibration ID	Service \$09 of SAE J1979

The above information can be checked using procedures listed in the table below.

×: Applicable —: Not applicable

	DTC	1st trip DTC	Freeze Frame data	1st trip Freeze Frame data	SRT code	SRT status	Test value
CONSULT-II	×	×	×	×	×	×	—
GST	×	×	×	—	×	×	×
ECM	×	×*	—	—	—	×	—

*: When DTC and 1st trip DTC simultaneously appear on the display, they cannot be clearly distinguished from each other.

The malfunction indicator lamp (MIL) on the instrument panel lights up when the same malfunction is detected in two consecutive trips (Two trip detection logic), or when the ECM enters fail-safe mode. (Refer to [EC-94, "Fail-Safe Chart"](#) .)

Two Trip Detection Logic

UBS00P19

When a malfunction is detected for the first time, 1st trip DTC and 1st trip Freeze Frame data are stored in the ECM memory. The MIL will not light up at this stage. <1st trip>

If the same malfunction is detected again during the next drive, the DTC and Freeze Frame data are stored in the ECM memory, and the MIL lights up. The MIL lights up at the same time when the DTC is stored. <2nd trip> The "trip" in the "Two Trip Detection Logic" means a driving mode in which self-diagnosis is performed during vehicle operation. Specific on board diagnostic items will cause the ECM to light up or blink the MIL, and store DTC and Freeze Frame data, even in the 1st trip, as shown below.

×: Applicable —: Not applicable

Items	MIL				DTC		1st trip DTC	
	1st trip		2nd trip		1st trip displaying	2nd trip displaying	1st trip displaying	2nd trip displaying
	Blinking	Lighting up	Blinking	Lighting up				
Misfire (Possible three way catalyst damage) — DTC: P0300 - P0306 is being detected	×	—	—	—	—	—	×	—
Misfire (Possible three way catalyst damage) — DTC: P0300 - P0306 is being detected	—	—	×	—	—	×	—	—
One trip detection diagnoses (Refer to EC-49, "EMISSION-RELATED DIAGNOSTIC INFORMATION ITEMS" .)	—	×	—	—	×	—	—	—
Except above	—	—	—	×	—	×	×	—

When there is an open circuit on MIL circuit, the ECM cannot warn the driver by lighting up MIL when there is malfunction on engine control system.

ON BOARD DIAGNOSTIC (OBD) SYSTEM

Therefore, when electrical controlled throttle and part of ECM related diagnoses are continuously detected as NG for 5 trips, ECM warns the driver that engine control system malfunctions and MIL circuit is open by means of operating fail-safe function.

The fail-safe function also operates when above diagnoses except MIL circuit are detected, and demands the driver to repair the malfunction.

Engine operating condition in fail-safe mode	Engine speed will not rise more than 2,500 rpm due to the fuel cut
--	--

Emission-related Diagnostic Information EMISSION-RELATED DIAGNOSTIC INFORMATION ITEMS

UBS00P1A

x: Applicable —: Not applicable

Items (CONSULT-II screen terms)	DTC*1		SRT code	Test value/ Test limit (GST only)	Trip	MIL lighting up	Reference page
	CONSULT-II GST*2	ECM*3					
CAN COMM CIRCUIT	U1000	1000*4	—	—	1	×	EC-159
CAN COMM CIRCUIT	U1001	1001*4	—	—	2	—	EC-159
CONTROL UNIT (CAN)	U1010	1010	—	—	1	×	EC-162
NO DTC IS DETECTED. FURTHER TESTING MAY BE REQUIRED.	P0000	0000	—	—	—	Flashing*5	EC-58
INT/V TIM CONT-B1	P0011	0011	—	—	2	×	EC-164
INT/V TIM CONT-B2	P0021	0021	—	—	2	×	EC-164
A/F SEN1 HTR (B1)	P0031	0031	—	×	2	×	EC-168
A/F SEN1 HTR (B1)	P0032	0032	—	×	2	×	EC-168
HO2S2 HTR (B1)	P0037	0037	—	×	2	×	EC-176
HO2S2 HTR (B1)	P0038	0038	—	×	2	×	EC-176
A/F SEN1 HTR (B2)	P0051	0051	—	×	2	×	EC-168
A/F SEN1 HTR (B2)	P0052	0052	—	×	2	×	EC-168
HO2S2 HTR (B2)	P0057	0057	—	×	2	×	EC-176
HO2S2 HTR (B2)	P0058	0058	—	×	2	×	EC-176
INT/V TIM V/CIR-B1	P0075	0075	—	—	2	×	EC-185
INT/V TIM V/CIR-B2	P0081	0081	—	—	2	×	EC-185
MAF SEN/CIRCUIT	P0101	0101	—	—	2	×	EC-192
MAF SEN/CIRCUIT	P0102	0102	—	—	1	×	EC-202
MAF SEN/CIRCUIT	P0103	0103	—	—	1	×	EC-202
IAT SEN/CIRCUIT	P0112	0112	—	—	2	×	EC-211
IAT SEN/CIRCUIT	P0113	0113	—	—	2	×	EC-211
ECT SEN/CIRC	P0117	0117	—	—	1	×	EC-216
ECT SEN/CIRC	P0118	0118	—	—	1	×	EC-216
TP SEN 2/CIRC	P0122	0122	—	—	1	×	EC-222
TP SEN 2/CIRC	P0123	0123	—	—	1	×	EC-222
ECT SENSOR	P0125	0125	—	—	2	×	EC-230
IAT SENSOR	P0127	0127	—	—	2	×	EC-234
THERMSTAT FNCTN	P0128	0128	—	—	2	×	EC-237
A/F SENSOR1 (B1)	P0130	0130	—	×	2	×	EC-239
A/F SENSOR1 (B1)	P0131	0131	—	×	2	×	EC-250
A/F SENSOR1 (B1)	P0132	0132	—	×	2	×	EC-260
A/F SENSOR1 (B1)	P0133	0133	×	×	2	×	EC-270
HO2S2 (B1)	P0137	0137	×	×	2	×	EC-283

ON BOARD DIAGNOSTIC (OBD) SYSTEM

Items (CONSULT-II screen terms)	DTC*1		SRT code	Test value/ Test limit (GST only)	Trip	MIL lighting up	Reference page
	CONSULT-II GST*2	ECM*3					
HO2S2 (B1)	P0138	0138	×	×	2	×	EC-295
HO2S2 (B1)	P0139	0139	×	×	2	×	EC-310
A/F SENSOR1 (B2)	P0150	0150	—	×	2	×	EC-239
A/F SENSOR1 (B2)	P0151	0151	—	×	2	×	EC-250
A/F SENSOR1 (B2)	P0152	0152	—	×	2	×	EC-260
A/F SENSOR1 (B2)	P0153	0153	×	×	2	×	EC-270
HO2S2 (B2)	P0157	0157	×	×	2	×	EC-283
HO2S2 (B2)	P0158	0158	×	×	2	×	EC-295
HO2S2 (B2)	P0159	0159	×	×	2	×	EC-310
FUEL SYS-LEAN-B1	P0171	0171	—	—	2	×	EC-322
FUEL SYS-RICH-B1	P0172	0172	—	—	2	×	EC-334
FUEL SYS-LEAN-B2	P0174	0174	—	—	2	×	EC-322
FUEL SYS-RICH-B2	P0175	0175	—	—	2	×	EC-334
FTT SENSOR	P0181	0181	—	—	2	×	EC-346
FTT SEN/CIRCUIT	P0182	0182	—	—	2	×	EC-352
FTT SEN/CIRCUIT	P0183	0183	—	—	2	×	EC-352
TP SEN 1/CIRC	P0222	0222	—	—	1	×	EC-357
TP SEN 1/CIRC	P0223	0223	—	—	1	×	EC-357
MULTI CYL MISFIRE	P0300	0300	—	—	2	×	EC-365
CYL 1 MISFIRE	P0301	0301	—	—	2	×	EC-365
CYL 2 MISFIRE	P0302	0302	—	—	2	×	EC-365
CYL 3 MISFIRE	P0303	0303	—	—	2	×	EC-365
CYL 4 MISFIRE	P0304	0304	—	—	2	×	EC-365
CYL 5 MISFIRE	P0305	0305	—	—	2	×	EC-365
CYL 6 MISFIRE	P0306	0306	—	—	2	×	EC-365
KNOCK SEN/CIRC-B1	P0327	0327	—	—	2	—	EC-374
KNOCK SEN/CIRC-B1	P0328	0328	—	—	2	—	EC-374
CKP SEN/CIRCUIT	P0335	0335	—	—	2	×	EC-379
CMP SEN/CIRC-B1	P0340	0340	—	—	2	×	EC-387
CMP SEN/CIRC-B2	P0345	0345	—	—	2	×	EC-387
EGR SYSTEM	P0400	0400	×	×	2	×	EC-397
EGR VOL CON/V CIR	P0403	0403	—	—	1	×	EC-405
EGR TEMP SEN/ CIRC	P0405	0405	—	—	2	×	EC-412
EGR TEMP SEN/ CIRC	P0406	0406	—	—	2	×	EC-412
TW CATALYST SYS-B1	P0420	0420	×	×	2	×	EC-419
TW CATALYST SYS-B2	P0430	0430	×	×	2	×	EC-419
EVAP PURG FLOW/MON	P0441	0441	×	×	2	×	EC-425
EVAP SMALL LEAK	P0442	0442	×	×	2	×	EC-431
PURG VOLUME CONT/V	P0443	0443	—	—	2	×	EC-439
PURG VOLUME CONT/V	P0444	0444	—	—	2	×	EC-447
PURG VOLUME CONT/V	P0445	0445	—	—	2	×	EC-447
VENT CONTROL VALVE	P0447	0447	—	—	2	×	EC-454

ON BOARD DIAGNOSTIC (OBD) SYSTEM

Items (CONSULT-II screen terms)	DTC*1		SRT code	Test value/ Test limit (GST only)	Trip	MIL lighting up	Reference page
	CONSULT-II GST*2	ECM*3					
VENT CONTROL VALVE	P0448	0448	—	—	2	×	EC-461
EVAP SYS PRES SEN	P0451	0451	—	—	2	×	EC-468
EVAP SYS PRES SEN	P0452	0452	—	—	2	×	EC-472
EVAP SYS PRES SEN	P0453	0453	—	—	2	×	EC-479
EVAP GROSS LEAK	P0455	0455	—	—	2	×	EC-487
EVAP VERY SML LEAK	P0456	0456	×*6	×	2	×	EC-495
FUEL LEV SEN SLOSH	P0460	0460	—	—	2	×	EC-504
FUEL LEVEL SENSOR	P0461	0461	—	—	2	×	EC-506
FUEL LEVL SEN/CIRC	P0462	0462	—	—	2	×	EC-508
FUEL LEVL SEN/CIRC	P0463	0463	—	—	2	×	EC-508
VEH SPEED SEN/CIRC*5	P0500	0500	—	—	2	×	EC-510
ISC SYSTEM	P0506	0506	—	—	2	×	EC-512
ISC SYSTEM	P0507	0507	—	—	2	×	EC-514
PW ST P SEN/CIRC	P0550	0550	—	—	2	—	EC-516
ECM BACK UP/CIRCUIT	P0603	0603	—	—	2	×	EC-522
ECM	P0605	0605	—	—	1 or 2	× or —	EC-526
SENSOR POWER/CIRC	P0643	0643	—	—	1	×	EC-529
PNP SW/CIRC	P0705	0705	—	—	1	×	AT-91
ATF TEMP SEN/CIRC	P0710	0710	—	—	2	×	AT-96
FLUID TEMP SEN	P0711	0711	—	—	2	×	AT-101
TURBINE SENSOR	P0717	0717	—	—	1	×	AT-106
VHCL SPEED SEN-AT	P0722	0722	—	—	1	×	AT-110
A/T 1ST GR FNCTN	P0731	0731	—	—	1	×	AT-116
A/T 2ND GR FNCTN	P0732	0732	—	—	1	×	AT-119
A/T 3RD GR FNCTN	P0733	0733	—	—	1	×	AT-124
A/T 4TH GR FNCTN	P0734	0734	—	—	1	×	AT-129
A/T 5TH GR FNCTN	P0735	0735	—	—	1	×	AT-133
A/T TCC S/V FNCTN	P0744	0744	—	—	1	×	AT-138
PC SOL A(L/PRESS)	P0745	0745	—	—	1	×	AT-141
SHIFT SOL A	P0750	0750	—	—	1	×	AT-146
SHIFT SOL B	P0755	0755	—	—	1	×	AT-151
SHIFT SOL C	P0760	0760	—	—	1	×	AT-156
SFT SOL C STUCK ON	P0762	0762	—	—	1	×	AT-161
SHIFT SOL D	P0765	0765	—	—	1	×	AT-166
SHIFT SOL E	P0770	0770	—	—	1	×	AT-171
PC SOL B(SFT/PRS)	P0775	0775	—	—	1	×	AT-176
SHIFT	P0780	0780	—	—	1	×	AT-181
PC SOL C(TCC&SFT)	P0795	0795	—	—	1	×	AT-185
PC SOL C STC ON	P0797	0797	—	—	1	×	AT-190
P-N POS SW/CIRCUIT	P0850	0850	—	—	2	×	EC-535
TCM POWER INPT SIG	P0882	0882	—	—	1	×	AT-199
CLOSED LOOP-B1	P1148	1148	—	—	1	×	EC-541

A
EC
C
D
E
F
G
H
I
J
K
L
M

ON BOARD DIAGNOSTIC (OBD) SYSTEM

Items (CONSULT-II screen terms)	DTC*1		SRT code	Test value/ Test limit (GST only)	Trip	MIL lighting up	Reference page
	CONSULT-II GST*2	ECM*3					
CLOSED LOOP-B2	P1168	1168	—	—	1	×	EC-541
TCS C/U FUNCTN	P1211	1211	—	—	2	—	EC-542
TCS/CIRC	P1212	1212	—	—	2	—	EC-543
ENG OVER TEMP	P1217	1217	—	—	1	×	EC-544
CTP LEARNING	P1225	1225	—	—	2	—	EC-555
CTP LEARNING	P1226	1226	—	—	2	—	EC-557
EGR SYSTEM	P1402	1402	×	×	2	×	EC-559
COLD START CONTROL	P1421	1421	—	—	2	×	EC-566
ASCD SW	P1564	1564	—	—	1	—	EC-568
ASCD BRAKE SW	P1572	1572	—	—	1	—	EC-576
ASCD VHL SPD SEN	P1574	1574	—	—	1	—	EC-584
NATS MALFUNCTION	P1610 - P1615	1610 - 1615	—	—	2	—	BL-203
VIAS S/V CIRC	P1800	1800	—	—	2	—	EC-586
BRAKE SW/CIRCUIT	P1805	1805	—	—	2	—	EC-591
ETC MOT PWR	P2100	2100	—	—	1	×	EC-596
ETC FUNCTION/CIRC	P2101	2101	—	—	1	×	EC-602
ETC MOT PWR	P2103	2103	—	—	1	×	EC-596
ETC MOT	P2118	2118	—	—	1	×	EC-609
ETC ACTR	P2119	2119	—	—	1	×	EC-615
APP SEN 1/CIRC	P2122	2122	—	—	1	×	EC-617
APP SEN 1/CIRC	P2123	2123	—	—	1	×	EC-617
APP SEN 2/CIRC	P2127	2127	—	—	1	×	EC-624
APP SEN 2/CIRC	P2128	2128	—	—	1	×	EC-624
TP SENSOR	P2135	2135	—	—	1	×	EC-632
APP SENSOR	P2138	2138	—	—	1	×	EC-640
A/F SENSOR1 (B1)	P2A00	2A00	—	×	2	×	EC-648
A/F SENSOR1 (B2)	P2A03	2A03	—	×	2	×	EC-648

*1: 1st trip DTC No. is the same as DTC No.

*2: This number is prescribed by SAE J2012.

*3: In Diagnostic Test Mode II (Self-diagnostic results), this number is controlled by NISSAN.

*4: The troubleshooting for this DTC needs CONSULT-II.

*5: When the ECM is in the mode of displaying SRT status, MIL may flash. For the details, refer to [EC-58, "How to Display SRT Status"](#).

*6: SRT code will not be set if the self-diagnostic result is NG.

DTC AND 1ST TRIP DTC

The 1st trip DTC (whose number is the same as the DTC number) is displayed for the latest self-diagnostic result obtained. If the ECM memory was cleared previously, and the 1st trip DTC did not reoccur, the 1st trip DTC will not be displayed.

If a malfunction is detected during the 1st trip, the 1st trip DTC is stored in the ECM memory. The MIL will not light up (two trip detection logic). If the same malfunction is not detected in the 2nd trip (meeting the required driving pattern), the 1st trip DTC is cleared from the ECM memory. If the same malfunction is detected in the 2nd trip, both the 1st trip DTC and DTC are stored in the ECM memory and the MIL lights up. In other words, the DTC is stored in the ECM memory and the MIL lights up when the same malfunction occurs in two consecutive trips. If a 1st trip DTC is stored and a non-diagnostic operation is performed between the 1st and 2nd trips, only the 1st trip DTC will continue to be stored. For malfunctions that blink or light up the MIL during the 1st trip, the DTC and 1st trip DTC are stored in the ECM memory.

ON BOARD DIAGNOSTIC (OBD) SYSTEM

Procedures for clearing the DTC and the 1st trip DTC from the ECM memory are described in [EC-63, "HOW TO ERASE EMISSION-RELATED DIAGNOSTIC INFORMATION"](#).

For malfunctions in which 1st trip DTCs are displayed, refer to [EC-49, "EMISSION-RELATED DIAGNOSTIC INFORMATION ITEMS"](#). These items are required by legal regulations to continuously monitor the system/component. In addition, the items monitored non-continuously are also displayed on CONSULT-II.

1st trip DTC is specified in Service \$07 of SAE J1979. 1st trip DTC detection occurs without lighting up the MIL and therefore does not warn the driver of a malfunction. However, 1st trip DTC detection will not prevent the vehicle from being tested, for example during Inspection/Maintenance (I/M) tests.

When a 1st trip DTC is detected, check, print out or write down and erase (1st trip) DTC and Freeze Frame data as specified in Work Flow procedure Step 2, refer to [EC-87, "WORK FLOW"](#). Then perform DTC Confirmation Procedure or Overall Function Check to try to duplicate the malfunction. If the malfunction is duplicated, the item requires repair.

How to Read DTC and 1st Trip DTC

DTC and 1st trip DTC can be read by the following methods.

 **With CONSULT-II**

 **With GST**

CONSULT-II or GST (Generic Scan Tool) Examples: P0340, P0850, P1148, etc. These DTCs are prescribed by SAE J2012.

(CONSULT-II also displays the malfunctioning component or system.)

 **No Tools**

The number of blinks of the MIL in the Diagnostic Test Mode II (Self-Diagnostic Results) indicates the DTC. Example: 0340, 0850, 1148, etc.

These DTCs are controlled by NISSAN.

- **1st trip DTC No. is the same as DTC No.**
- **Output of a DTC indicates a malfunction. However, GST or the Diagnostic Test Mode II do not indicate whether the malfunction is still occurring or has occurred in the past and has returned to normal. CONSULT-II can identify malfunction status as shown below. Therefore, using CONSULT-II (if available) is recommended.**

A sample of CONSULT-II display for DTC and 1st trip DTC is shown below. DTC or 1st trip DTC of a malfunction is displayed in "SELF-DIAGNOSTIC RESULTS" mode of CONSULT-II. Time data indicates how many times the vehicle was driven after the last detection of a DTC.

If the DTC is being detected currently, the time data will be [0].

If a 1st trip DTC is stored in the ECM, the time data will be [1t].

DTC display	SELF DIAG RESULTS		1st trip DTC display	SELF DIAG RESULTS	
	DTC RESULTS	TIME		DTC RESULTS	TIME
	CKP SEN/CIRCUIT [P0335]	0		CKP SEN/CIRCUIT [P0335]	1t

PBIB0911E

FREEZE FRAME DATA AND 1ST TRIP FREEZE FRAME DATA

The ECM records the driving conditions such as fuel system status, calculated load value, engine coolant temperature, short term fuel trim, long term fuel trim, engine speed, vehicle speed, absolute throttle position, base fuel schedule and intake air temperature at the moment a malfunction is detected.

Data which are stored in the ECM memory, along with the 1st trip DTC, are called 1st trip freeze frame data. The data, stored together with the DTC data, are called freeze frame data and displayed on CONSULT-II or GST. The 1st trip freeze frame data can only be displayed on the CONSULT-II screen, not on the GST. For details, see [EC-122, "Freeze Frame Data and 1st Trip Freeze Frame Data"](#).

Only one set of freeze frame data (either 1st trip freeze frame data or freeze frame data) can be stored in the ECM. 1st trip freeze frame data is stored in the ECM memory along with the 1st trip DTC. There is no priority for 1st trip freeze frame data and it is updated each time a different 1st trip DTC is detected. However, once freeze frame data (2nd trip detection/MIL on) is stored in the ECM memory, 1st trip freeze frame data is no longer stored. Remember, only one set of freeze frame data can be stored in the ECM. The ECM has the following priorities to update the data.

ON BOARD DIAGNOSTIC (OBD) SYSTEM

Priority	Items	
1	Freeze frame data	Misfire — DTC: P0300 - P0306 Fuel Injection System Function — DTC: P0171, P0172, P0174, P0175
2		Except the above items (Includes A/T related items)
3	1st trip freeze frame data	

For example, the EGR malfunction (Priority: 2) was detected and the freeze frame data was stored in the 2nd trip. After that when the misfire (Priority: 1) is detected in another trip, the freeze frame data will be updated from the EGR malfunction to the misfire. The 1st trip freeze frame data is updated each time a different malfunction is detected. There is no priority for 1st trip freeze frame data. However, once freeze frame data is stored in the ECM memory, 1st trip freeze data is no longer stored (because only one freeze frame data or 1st trip freeze frame data can be stored in the ECM). If freeze frame data is stored in the ECM memory and freeze frame data with the same priority occurs later, the first (original) freeze frame data remains unchanged in the ECM memory.

Both 1st trip freeze frame data and freeze frame data (along with the DTCs) are cleared when the ECM memory is erased. Procedures for clearing the ECM memory are described in [EC-63, "HOW TO ERASE EMISSION-RELATED DIAGNOSTIC INFORMATION"](#).

SYSTEM READINESS TEST (SRT) CODE

System Readiness Test (SRT) code is specified in Service \$01 of SAE J1979.

As part of an enhanced emissions test for Inspection & Maintenance (I/M), certain states require the status of SRT be used to indicate whether the ECM has completed self-diagnosis of major emission systems and components. Completion must be verified in order for the emissions inspection to proceed.

If a vehicle is rejected for a State emissions inspection due to one or more SRT items indicating "INCMP", use the information in this Service Manual to set the SRT to "CMPLT".

In most cases the ECM will automatically complete its self-diagnosis cycle during normal usage, and the SRT status will indicate "CMPLT" for each application system. Once set as "CMPLT", the SRT status remains "CMPLT" until the self-diagnosis memory is erased.

Occasionally, certain portions of the self-diagnostic test may not be completed as a result of the customer's normal driving pattern; the SRT will indicate "INCMP" for these items.

NOTE:

The SRT will also indicate "INCMP" if the self-diagnosis memory is erased for any reason or if the ECM memory power supply is interrupted for several hours.

If, during the state emissions inspection, the SRT indicates "CMPLT" for all test items, the inspector will continue with the emissions test. However, if the SRT indicates "INCMP" for one or more of the SRT items the vehicle is returned to the customer untested.

NOTE:

If MIL is ON during the state emissions inspection, the vehicle is also returned to the customer untested even though the SRT indicates "CMPLT" for all test items. Therefore, it is important to check SRT ("CMPLT") and DTC (No DTCs) before the inspection.

SRT Item

The table below shows required self-diagnostic items to set the SRT to "CMPLT".

SRT item (CONSULT-II indication)	Performance Priority*	Required self-diagnostic items to set the SRT to "CMPLT"	Corresponding DTC No.
CATALYST	3	Three way catalyst function	P0420, P0430
EVAP SYSTEM	3	EVAP control system purge flow monitoring	P0441
	2	EVAP control system	P0442
	3	EVAP control system	P0456
HO2S	3	A/F sensor 1	P0133, P0153
		Heated oxygen sensor 2	P0137, P0157
		Heated oxygen sensor 2	P0138, P0158
		Heated oxygen sensor 2	P0139, P0159
EGR SYSTEM	3	EGR function	P0400
	1	EGR function	P1402

ON BOARD DIAGNOSTIC (OBD) SYSTEM

*: If completion of several SRTs is required, perform driving patterns (DTC confirmation procedure), one by one based on the priority for models with CONSULT-II.

A

EC

C

D

E

F

G

H

I

J

K

L

M

ON BOARD DIAGNOSTIC (OBD) SYSTEM

SRT Set Timing

SRT is set as “CMPLT” after self-diagnosis has been performed one or more times. Completion of SRT is done regardless of whether the result is OK or NG. The set timing is different between OK and NG results and is shown in the table below.

Self-diagnosis result		Example							
		Diagnosis	Ignition cycle						
	← ON →		OFF	← ON →	OFF	← ON →	OFF	← ON →	
All OK	Case 1	P0400	OK (1)	— (1)	OK (2)	— (2)			
		P0402	OK (1)	— (1)	— (1)	OK (2)			
		P1402	OK (1)	OK (2)	— (2)	— (2)			
		SRT of EGR	“CMPLT”	“CMPLT”	“CMPLT”	“CMPLT”			
	Case 2	P0400	OK (1)	— (1)	— (1)	— (1)			
		P0402	— (0)	— (0)	OK (1)	— (1)			
		P1402	OK (1)	OK (2)	— (2)	— (2)			
		SRT of EGR	“INCMP”	“INCMP”	“CMPLT”	“CMPLT”			
NG exists	Case 3	P0400	OK	OK	—	—			
		P0402	—	—	—	—			
		P1402	NG	—	NG	NG	NG (Consecutive NG)		
		(1st trip) DTC	1st trip DTC	—	1st trip DTC	DTC (= MIL “ON”)			
		SRT of EGR	“INCMP”	“INCMP”	“INCMP”	“CMPLT”			

OK: Self-diagnosis is carried out and the result is OK.

NG: Self-diagnosis is carried out and the result is NG.

—: Self-diagnosis is not carried out.

When all SRT related self-diagnoses showed OK results in a single cycle (Ignition OFF-ON-OFF), the SRT will indicate “CMPLT”. → Case 1 above

When all SRT related self-diagnoses showed OK results through several different cycles, the SRT will indicate “CMPLT” at the time the respective self-diagnoses have at least one OK result. → Case 2 above

If one or more SRT related self-diagnoses showed NG results in 2 consecutive cycles, the SRT will also indicate “CMPLT”. → Case 3 above

The table above shows that the minimum number of cycles for setting SRT as “INCMP” is one (1) for each self-diagnosis (Case 1 & 2) or two (2) for one of self-diagnoses (Case 3). However, in preparation for the state emissions inspection, it is unnecessary for each self-diagnosis to be executed twice (Case 3) for the following reasons:

- The SRT will indicate “CMPLT” at the time the respective self-diagnoses have one (1) OK result.
- The emissions inspection requires “CMPLT” of the SRT only with OK self-diagnosis results.
- When, during SRT driving pattern, 1st trip DTC (NG) is detected prior to “CMPLT” of SRT, the self-diagnosis memory must be erased from ECM after repair.
- If the 1st trip DTC is erased, all the SRT will indicate “INCMP”.

NOTE:

SRT can be set as “CMPLT” together with the DTC(s). Therefore, DTC check must always be carried out prior to the state emission inspection even though the SRT indicates “CMPLT”.

ON BOARD DIAGNOSTIC (OBD) SYSTEM

SRT Service Procedure

If a vehicle has failed the state emissions inspection due to one or more SRT items indicating "INCMP", review the flowchart diagnostic sequence on the next page.

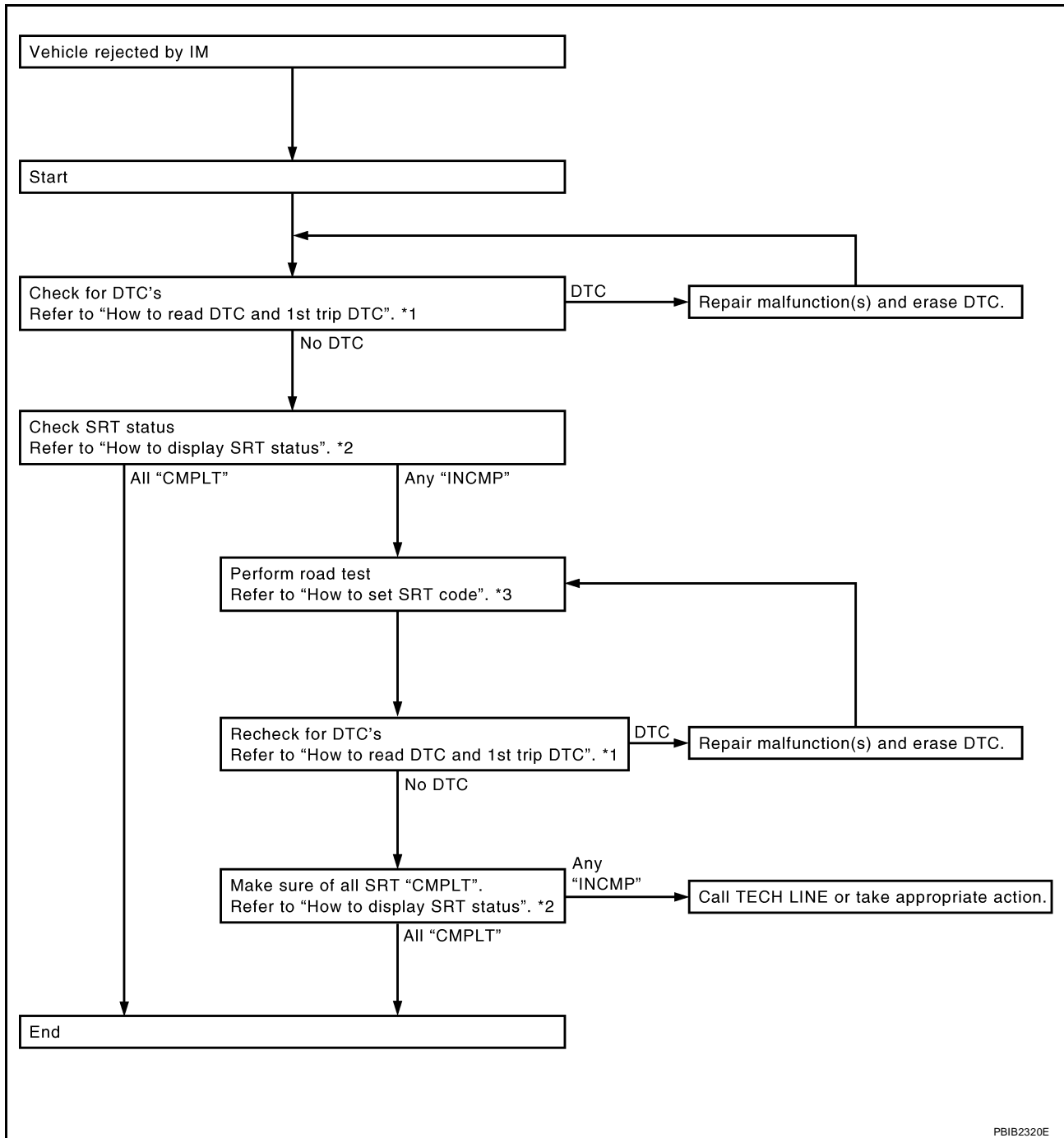

*1 [EC-53, "How to Read DTC and 1st Trip DTC"](#)

*2 [EC-58, "How to Display SRT Status"](#)

*3 [EC-58, "How to Set SRT Code"](#)

PBIB2320E

ON BOARD DIAGNOSTIC (OBD) SYSTEM

How to Display SRT Status

WITH CONSULT-II

Selecting "SRT STATUS" in "DTC CONFIRMATION" mode with CONSULT-II.

For items whose SRT codes are set, a "CMPLT" is displayed on the CONSULT-II screen; for items whose SRT codes are not set, "INCMP" is displayed.

A sample of CONSULT-II display for SRT code is shown in the figure.

"INCMP" means the self-diagnosis is incomplete and SRT is not set. "CMPLT" means the self-diagnosis is complete and SRT is set.

NOTE:

Though displayed on the CONSULT-II screen, "HO2S HTR" is not SRT item.

SRT STATUS	
CATALYST	CMPLT
EVAP SYSTEM	INCMP
HO2S HTR	CMPLT
HO2S	CMPLT
EGR SYSTEM	INCMP

SEF713Y

WITH GST

Selecting Service \$01 with GST (Generic Scan Tool)

NO TOOLS

A SRT code itself can be displayed while only SRT status can be.

1. Turn ignition switch ON and wait 20 seconds.
2. SRT status is indicated as shown below.
 - When all SRT codes are set, MIL lights up continuously.
 - When any SRT codes are not set, MIL will flash periodically for 10 seconds.

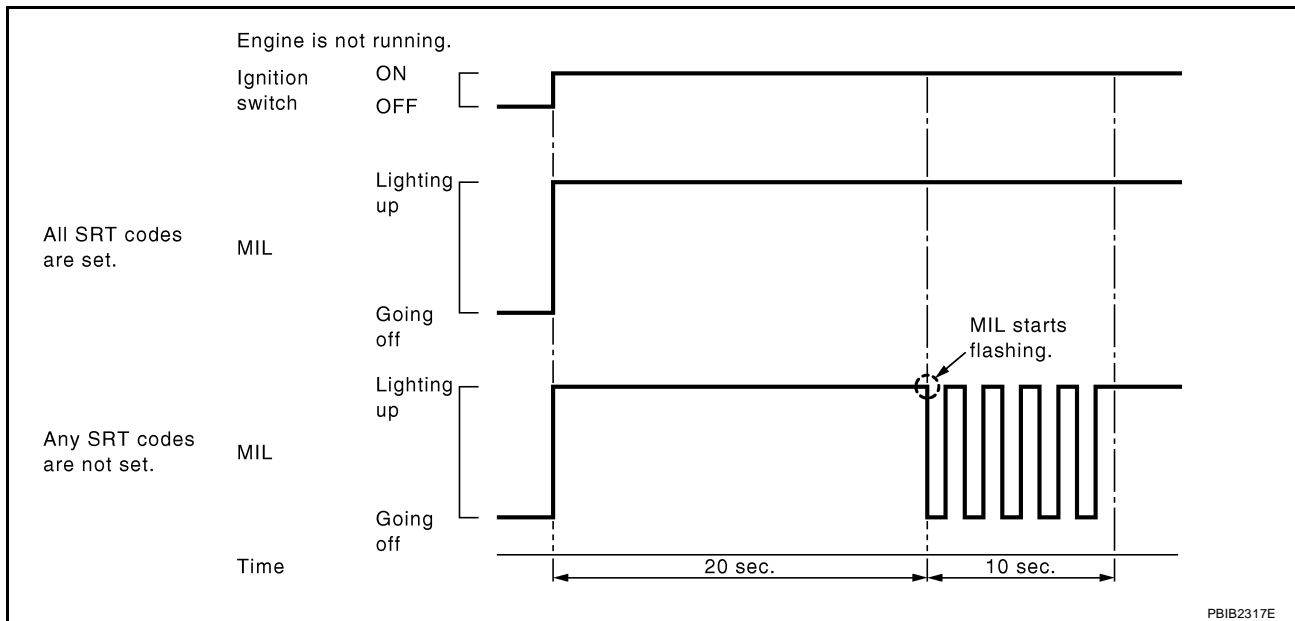

How to Set SRT Code

To set all SRT codes, self-diagnosis for the items indicated above must be performed one or more times. Each diagnosis may require a long period of actual driving under various conditions.

WITH CONSULT-II

Perform corresponding DTC Confirmation Procedure one by one based on Performance Priority in the table on [EC-54, "SRT Item"](#).

WITHOUT CONSULT-II

The most efficient driving pattern in which SRT codes can be properly set is explained on the next page. The driving pattern should be performed one or more times to set all SRT codes.

ON BOARD DIAGNOSTIC (OBD) SYSTEM

Driving Pattern

Note: Always drive vehicle in safe manner according to traffic conditions and obey all traffic laws. Refer to next page for more information and explanation of chart.

Driving pattern

SRT item (CONSULT-II screen term)	Self-diagnostic test item	Pattern 1	Pattern 2	Pattern 3	Pattern 4
CATALYST	Three way catalyst function		■		
EVAP SYSTEM	EVAP control system purge flow monitoring			■	
	EVAP control system			▨	
HO2S	A/F sensor 1		■		
	Heated oxygen sensor 2		▨		
EGR SYSTEM	EGR function	■			

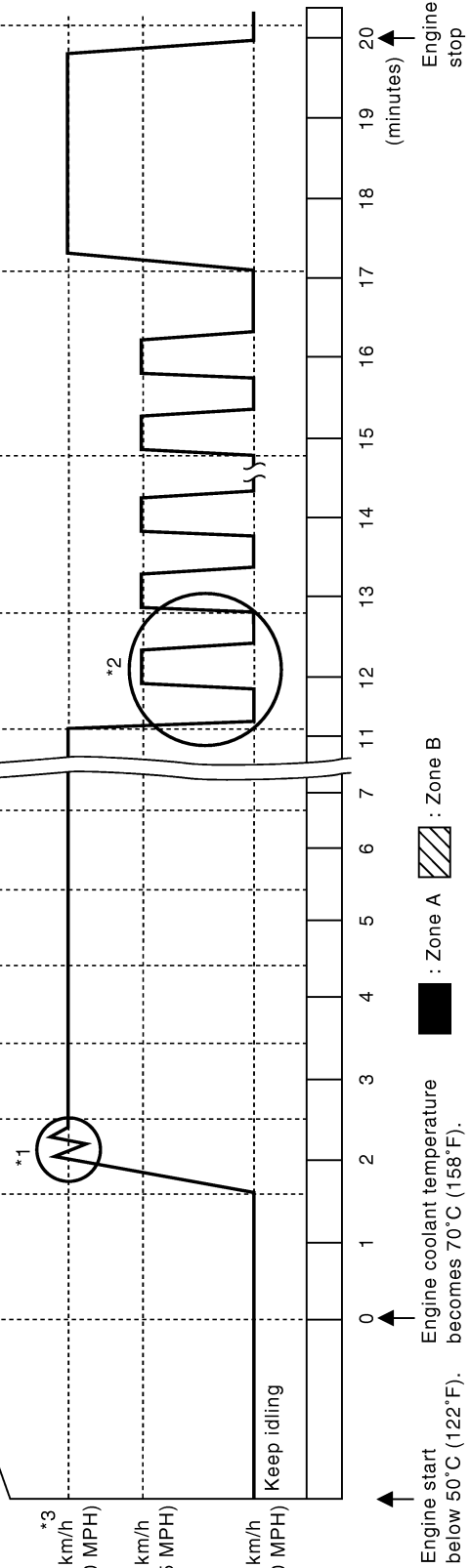

Engine start below 50°C (122°F).
 Engine coolant temperature becomes 70°C (158°F).
 ■ : Zone A
 ▨ : Zone B

PBIB3070E

ON BOARD DIAGNOSTIC (OBD) SYSTEM

- The time required for each diagnosis varies with road surface conditions, weather, altitude, individual driving habits, etc.
Zone A refers to the range where the time, required for the diagnosis under normal conditions*, is the shortest.
Zone B refers to the range where the diagnosis can still be performed if the diagnosis is not completed within zone A.

*: Normal conditions refer to the following:

- Sea level
- Flat road
- Ambient air temperature: 20 - 30°C (68 - 86°F)
- Diagnosis is performed as quickly as possible under normal conditions.
Under different conditions [For example: ambient air temperature other than 20 - 30°C (68 - 86°F)], diagnosis may also be performed.

Pattern 1:

- **The engine is started at the engine coolant temperature of -10 to 35°C (14 to 95°F) (where the voltage between the ECM terminal 73 and ground is 3.0 - 4.3V).**
- **The engine must be operated at idle speed until the engine coolant temperature is greater than 70°C (158°F) (where the voltage between the ECM terminal 73 and ground is lower than 1.4V).**
- **The engine is started at the fuel tank temperature of warmer than 0°C (32°F) (where the voltage between the ECM terminal 107 and ground is less than 4.1V).**

Pattern 2:

- When steady-state driving is performed again even after it is interrupted, each diagnosis can be conducted. In this case, the time required for diagnosis may be extended.

Pattern 3:

- The driving pattern outlined in *2 must be repeated at least 3 times.

Pattern 4:

- Tests are performed after the engine has been operated for at least 17 minutes.
- The accelerator pedal must be held very steady during steady-state driving.
- If the accelerator pedal is moved, the test must be conducted all over again.

*1: Depress the accelerator pedal until vehicle speed is 90 km/h (56 MPH), then release the accelerator pedal and keep it released for more than 10 seconds. Depress the accelerator pedal until vehicle speed is 90 km/h (56 MPH) again.

*2: Operate the vehicle in the following driving pattern.

1. Decelerate vehicle to 0 km/h (0 MPH) and let engine idle.
2. Repeat driving pattern shown at right at least 10 times.
- **During acceleration, hold the accelerator pedal as steady as possible.**

*3: Checking the vehicle speed with GST is advised.

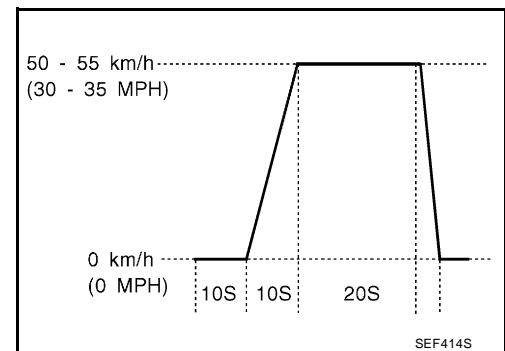

Suggested Transmission Gear Position

Set the shift lever in the D position with the overdrive switch turned ON.

ON BOARD DIAGNOSTIC (OBD) SYSTEM

TEST VALUE AND TEST LIMIT (GST ONLY — NOT APPLICABLE TO CONSULT-II)

The following is the information specified in Service \$06 of SAE J1979.

The test value is a parameter used to determine whether a system/circuit diagnostic test is OK or NG while being monitored by the ECM during self-diagnosis. The test limit is a reference value which is specified as the maximum or minimum value and is compared with the test value being monitored.

These data (test value and test limit) are specified by Test ID (TID) and Component ID (CID) and can be displayed on the GST screen.

SRT item	Self-diagnostic test item	DTC	Test value (GST display)		Test limit	Unit
			TID	CID		
CATALYST	Three way catalyst function (Bank 1)	P0420	01H	01H	Max.	1/128
		P0420	02H	81H	Min.	1
	Three way catalyst function (Bank 2)	P0430	03H	02H	Max.	1/128
		P0430	04H	82H	Min.	1
EVAP SYSTEM	EVAP control system (Small leak)	P0442	05H	03H	Max.	1/128 mm ²
	EVAP control system purge flow monitoring	P0441	06H	83H	Min.	20 mV
	EVAP control system (Very small leak)	P0456	07H	03H	Max.	1/128 mm ²
HO2S	A/F sensor 1 (Bank 1)	P0131	41H	8EH	Min.	5 mV
		P0132	42H	0EH	Max.	5 mV
		P2A00	43H	0EH	Max.	0.002
		P2A00	44H	8EH	Min.	0.002
		P0133	45H	8EH	Min.	0.004
		P0130	46H	0EH	Max.	5 mV
		P0130	47H	8EH	Min.	5 mV
		P0133	48H	8EH	Min.	0.004
	A/F sensor 1 (Bank 2)	P0151	4CH	8FH	Min.	5 mV
		P0152	4DH	0FH	Max.	5 mV
		P2A03	4EH	0FH	Max.	0.002
		P2A03	4FH	8FH	Min.	0.002
		P0153	50H	8FH	Min.	0.004
		P0150	51H	0FH	Max.	5 mV
		P0150	52H	8FH	Min.	5 mV
		P0153	53H	8FH	Min.	0.004
	Heated oxygen sensor 2 (Bank 1)	P0139	19H	86H	Min.	10mV/500 ms
		P0137	1AH	86H	Min.	10 mV
		P0138	1BH	06H	Max.	10 mV
		P0138	1CH	06H	Max.	10 mV
	Heated oxygen sensor 2 (Bank 2)	P0159	21H	87H	Min.	10mV/500 ms
		P0157	22H	87H	Min.	10 mV
		P0158	23H	07H	Max.	10 mV
		P0158	24H	07H	Max.	10 mV

ON BOARD DIAGNOSTIC (OBD) SYSTEM

SRT item	Self-diagnostic test item	DTC	Test value (GST display)		Test limit	Unit
			TID	CID		
HO2S HTR	A/F sensor 1 heater (Bank 1)	P0032	57H	10H	Max.	5 mV
		P0031	58H	90H	Min.	5 mV
	A/F sensor 1 heater (Bank 2)	P0052	59H	11H	Max.	5 mV
		P0051	5AH	91H	Min.	5 mV
	Heated oxygen sensor 2 heater (Bank 1)	P0038	2DH	0AH	Max.	20 mV
		P0037	2EH	8AH	Min.	20 mV
	Heated oxygen sensor 2 heater (Bank 2)	P0058	2FH	0BH	Max.	20 mV
		P0057	30H	8BH	Min.	20 mV
EGR SYSTEM	EGR function	P0400	31H	8CH	Min.	1°C
		P0400	32H	8CH	Min.	1°C
		P0400	33H	8CH	Min.	1°C
		P0400	34H	8CH	Min.	1°C
		P1402	35H	0CH	Max.	1°C

ON BOARD DIAGNOSTIC (OBD) SYSTEM

HOW TO ERASE EMISSION-RELATED DIAGNOSTIC INFORMATION

How to Erase DTC

Ⓜ With CONSULT-II

The emission related diagnostic information in the ECM can be erased by selecting "ERASE" in the "SELF-DIAG RESULTS" mode with CONSULT-II.

If DTCs are displayed for both ECM and TCM (Transmission control module), they need to be erased individually from the ECM and TCM (Transmission control module).

NOTE:

If the DTC is not for AT related items (see [EC-8, "INDEX FOR DTC"](#)), skip steps 2 through 4.

1. If the ignition switch stays ON after repair work, be sure to turn ignition switch OFF once. Wait at least 10 seconds and then turn it ON (engine stopped) again.
2. Turn CONSULT-II ON and touch "TRANSMISSION".
3. Touch "SELF-DIAG RESULTS".
4. Touch "ERASE". [The DTC in the TCM (Transmission control module) will be erased.] Then touch "BACK" twice.
5. Touch "ENGINE".
6. Touch "SELF-DIAG RESULTS".
7. Touch "ERASE". (The DTC in the ECM will be erased.)

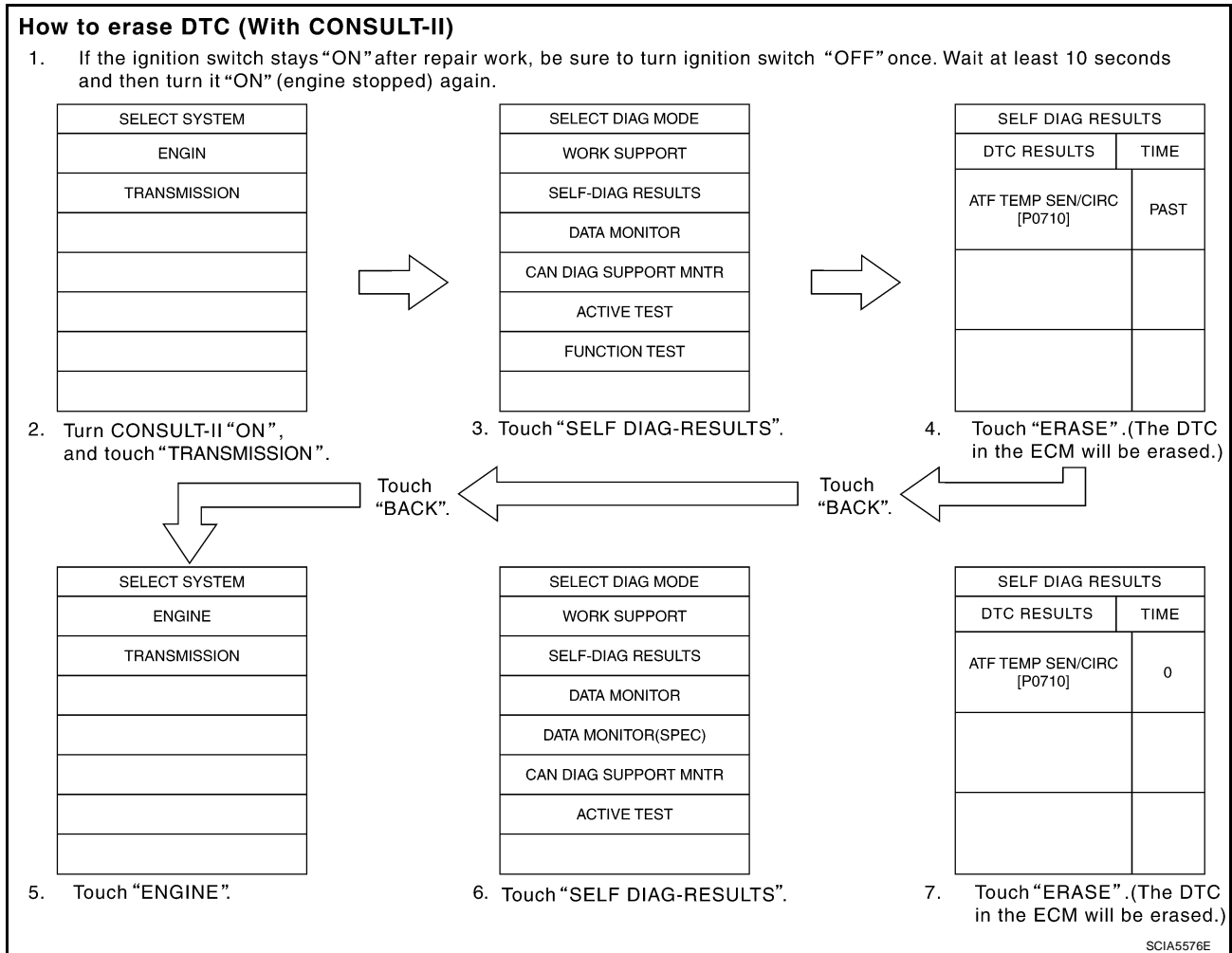

Ⓜ With GST

The emission related diagnostic information in the ECM can be erased by selecting Service \$04 with GST.

NOTE:

If the DTC is not for AT related items (see [EC-8, "INDEX FOR DTC"](#)), skip step 2.

1. If the ignition switch stays ON after repair work, be sure to turn ignition switch OFF once. Wait at least 10 seconds and then turn it ON (engine stopped) again.

ON BOARD DIAGNOSTIC (OBD) SYSTEM

2. Perform [AT-42, "How to erase DTC \(with GST\)"](#) . (The DTC in the TCM will be erased.)
3. Select Service \$04 with GST (Generic Scan Tool).



No Tools

NOTE:

If the DTC is not for AT related items (see [EC-8, "INDEX FOR DTC"](#)), skip step 2.

1. If the ignition switch stays ON after repair work, be sure to turn ignition switch OFF once. Wait at least 10 seconds and then turn it ON (engine stopped) again.
 2. Perform [AT-42, "How to erase DTC \(no tools\)"](#) . (The DTC in the TCM will be erased.)
 3. Change the diagnostic test mode from Mode II to Mode I by depressing the accelerator pedal. Refer to [EC-65, "HOW TO SWITCH DIAGNOSTIC TEST MODE"](#) .
- **If the battery is disconnected, the emission-related diagnostic information will be lost within 24 hours.**
 - **The following data are cleared when the ECM memory is erased.**
 - Diagnostic trouble codes
 - 1st trip diagnostic trouble codes
 - Freeze frame data
 - 1st trip freeze frame data
 - System readiness test (SRT) codes
 - Test values

Actual work procedures are explained using a DTC as an example. Be careful so that not only the DTC, but all of the data listed above, are cleared from the ECM memory during work procedures.

Malfunction Indicator Lamp (MIL)

UBS00P1B

DESCRIPTION

The MIL is located on the instrument panel.



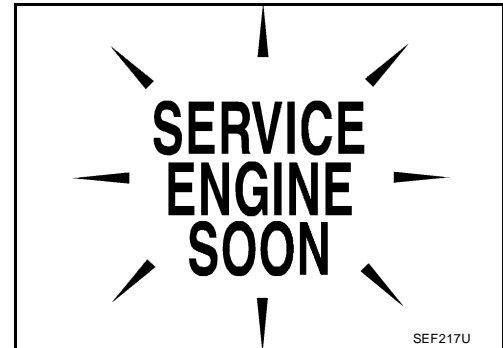

1. The MIL will light up when the ignition switch is turned ON without the engine running. This is a bulb check. If the MIL does not light up, refer to [DI-26, "WARNING LAMPS"](#) , or see [EC-719, "MIL AND DATA LINK CONNECTOR"](#) .
2. When the engine is started, the MIL should go off. If the MIL remains on, the on board diagnostic system has detected an engine system malfunction.



ON BOARD DIAGNOSTIC (OBD) SYSTEM

ON BOARD DIAGNOSTIC SYSTEM FUNCTION

The on board diagnostic system has the following three functions.

Diagnostic Test Mode	KEY and ENG. Status	Function	Explanation of Function
Mode I	Ignition switch in ON position  Engine stopped 	BULB CHECK	This function checks the MIL bulb for damage (blown, open circuit, etc.). If the MIL does not come on, check MIL circuit.
	Engine running 	MALFUNCTION WARNING	This is a usual driving condition. When a malfunction is detected twice in two consecutive driving cycles (two trip detection logic), the MIL will light up to inform the driver that a malfunction has been detected. The following malfunctions will light up or blink the MIL in the 1st trip. <ul style="list-style-type: none"> ● Misfire (Possible three way catalyst damage) ● One trip detection diagnoses
Mode II	Ignition switch in ON position  Engine stopped 	SELF-DIAGNOSTIC RESULTS	This function allows DTCs and 1st trip DTCs to be read.

When there is an open circuit on MIL circuit, the ECM cannot warn the driver by lighting up MIL when there is malfunction on engine control system.

Therefore, when electrical controlled throttle and part of ECM related diagnoses are continuously detected as NG for 5 trips, ECM warns the driver that engine control system malfunctions and MIL circuit is open by means of operating fail-safe function.

The fail-safe function also operates when above diagnoses except MIL circuit are detected, and demands the driver to repair the malfunction.

Engine operating condition in fail-safe mode	Engine speed will not rise more than 2,500 rpm due to the fuel cut
--	--

MIL Flashing Without DTC

When any SRT codes are not set, MIL may flash without DTC. For the details, refer to [EC-58, "How to Display SRT Status"](#).

HOW TO SWITCH DIAGNOSTIC TEST MODE

NOTE:

- It is better to count the time accurately with a clock.
- It is impossible to switch the diagnostic mode when an accelerator pedal position sensor circuit has a malfunction.
- Always ECM returns to Diagnostic Test Mode I after ignition switch is turned OFF.

How to Set Diagnostic Test Mode II (Self-diagnostic Results)

1. Confirm that accelerator pedal is fully released, turn ignition switch ON and wait 3 seconds.
2. Repeat the following procedure quickly five times within 5 seconds.
 - a. Fully depress the accelerator pedal.
 - b. Fully release the accelerator pedal.
3. Wait 7 seconds, fully depress the accelerator pedal and keep it for approx. 10 seconds until the MIL starts blinking.

ON BOARD DIAGNOSTIC (OBD) SYSTEM

NOTE:

Do not release the accelerator pedal for 10 seconds if MIL may start blinking on the halfway of this 10 seconds. This blinking is displaying SRT status and is continued for another 10 seconds. For the details, refer to [EC-58, "How to Display SRT Status"](#) .

4. Fully release the accelerator pedal.

NOTE:

Wait until the same DTC (or 1st trip DTC) appears to confirm all DTCs certainly. ECM has entered to Diagnostic Test Mode II (Self-diagnostic results).

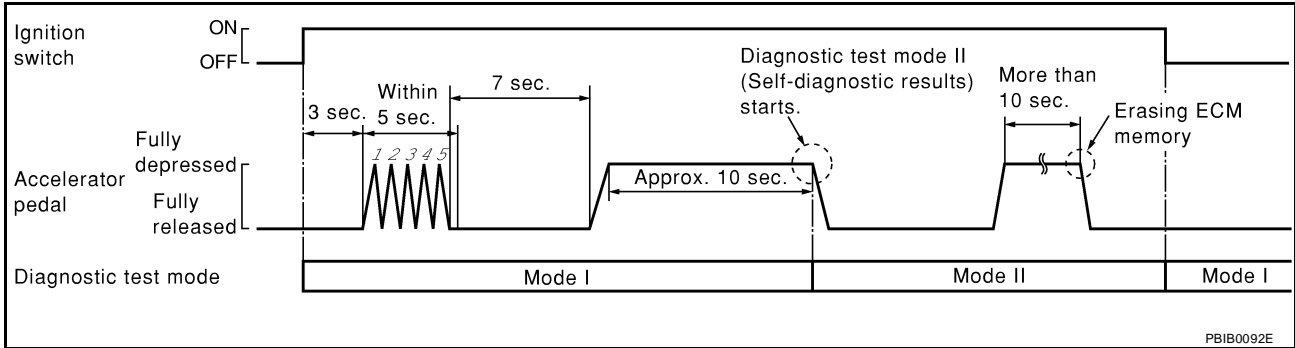

How to Erase Diagnostic Test Mode II (Self-diagnostic Results)

1. Set ECM in Diagnostic Test Mode II (Self-diagnostic results). Refer to [EC-65, "How to Set Diagnostic Test Mode II \(Self-diagnostic Results\)"](#) .
2. Fully depress the accelerator pedal and keep it for more than 10 seconds. The emission-related diagnostic information has been erased from the backup memory in the ECM.
3. Fully release the accelerator pedal, and confirm the DTC 0000 is displayed.

DIAGNOSTIC TEST MODE I — BULB CHECK

In this mode, the MIL on the instrument panel should stay ON. If it remains OFF, check the bulb. Refer to [DI-26, "WARNING LAMPS"](#) or see [EC-719, "MIL AND DATA LINK CONNECTOR"](#) .

DIAGNOSTIC TEST MODE I — MALFUNCTION WARNING

MIL	Condition
ON	When the malfunction is detected.
OFF	No malfunction.

These DTC numbers are clarified in Diagnostic Test Mode II (SELF-DIAGNOSTIC RESULTS)

ON BOARD DIAGNOSTIC (OBD) SYSTEM

DIAGNOSTIC TEST MODE II — SELF-DIAGNOSTIC RESULTS

In this mode, the DTC and 1st trip DTC are indicated by the number of blinks of the MIL as shown below. The DTC and 1st trip DTC are displayed at the same time. If the MIL does not illuminate in diagnostic test mode I (Malfunction warning), all displayed items are 1st trip DTCs. If only one code is displayed when the MIL illuminates in diagnostic test mode II (SELF-DIAGNOSTIC RESULTS), it is a DTC; if two or more codes are displayed, they may be either DTCs or 1st trip DTCs. DTC No. is same as that of 1st trip DTC. These unidentified codes can be identified by using the CONSULT-II or GST. A DTC will be used as an example for how to read a code.

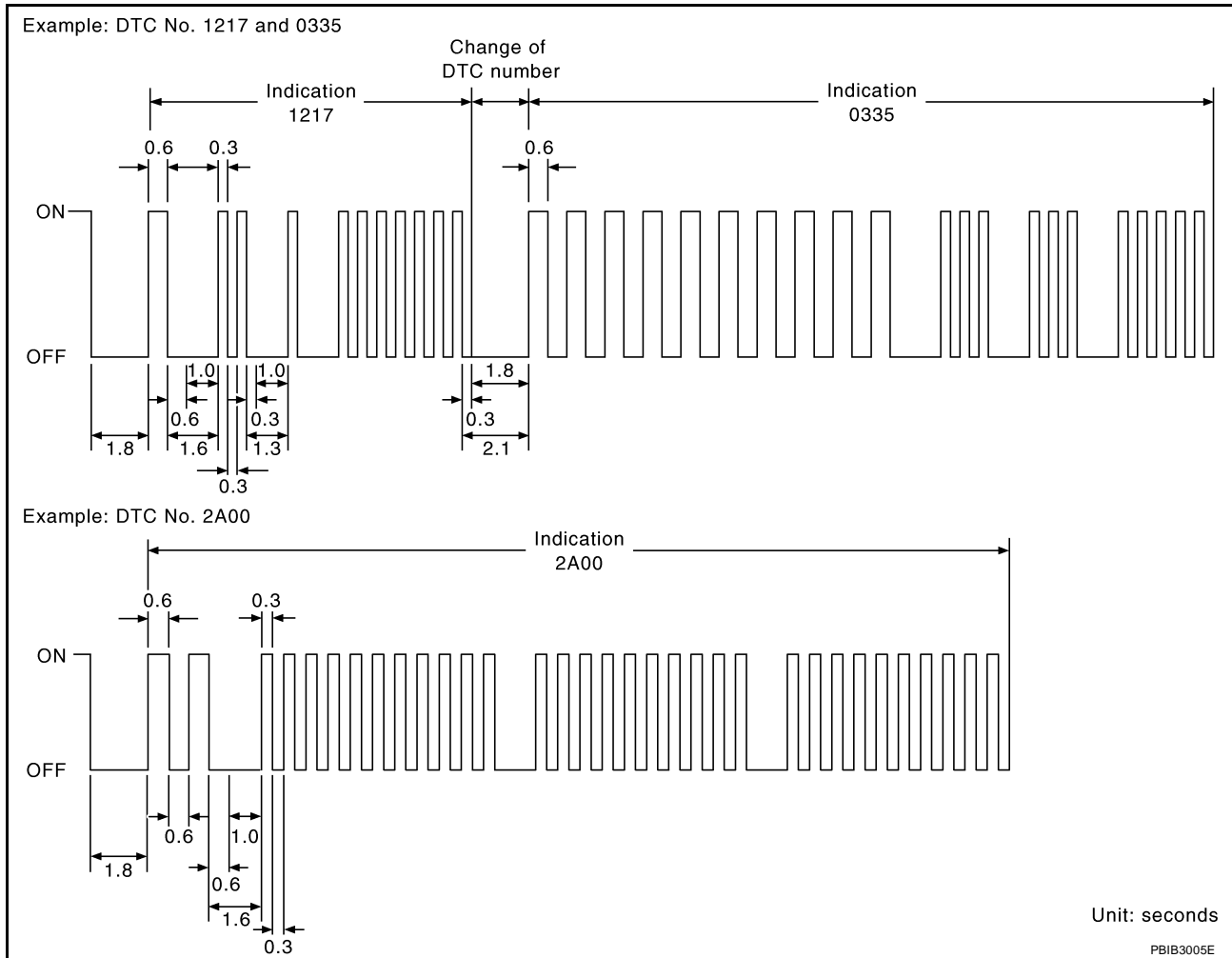

A particular trouble code can be identified by the number of four-digit numeral flashes. The “zero” is indicated by the number of ten flashes. The “A” is indicated by the number of eleven flash. The length of time the 1,000th-digit numeral flashes on and off is 1.2 seconds consisting of an ON (0.6-second) - OFF (0.6-second) cycle.

The 100th-digit numeral and lower digit numerals consist of a 0.3-second ON and 0.3-second OFF cycle. A change from one digit numeral to another occurs at an interval of 1.0-second OFF. In other words, the later numeral appears on the display 1.3 seconds after the former numeral has disappeared.

A change from one trouble code to another occurs at an interval of 1.8-second OFF.

In this way, all the detected malfunctions are classified by their DTC numbers. The DTC 0000 refers to no malfunction. (See [EC-8, "INDEX FOR DTC"](#))

How to Erase Diagnostic Test Mode II (Self-diagnostic Results)

The DTC can be erased from the back up memory in the ECM by depressing accelerator pedal. Refer to [EC-66, "How to Erase Diagnostic Test Mode II \(Self-diagnostic Results\)"](#) .

- If the battery is disconnected, the DTC will be lost from the backup memory within 24 hours.
- Be careful not to erase the stored memory before starting trouble diagnoses.

ON BOARD DIAGNOSTIC (OBD) SYSTEM

UBS00P1C

OBD System Operation Chart

RELATIONSHIP BETWEEN MIL, 1ST TRIP DTC, DTC, AND DETECTABLE ITEMS

- When a malfunction is detected for the first time, the 1st trip DTC and the 1st trip freeze frame data are stored in the ECM memory.
- When the same malfunction is detected in two consecutive trips, the DTC and the freeze frame data are stored in the ECM memory, and the MIL will come on. For details, refer to [EC-48, "Two Trip Detection Logic"](#).
- The MIL will go off after the vehicle is driven 3 times (driving pattern B) with no malfunction. The drive is counted only when the recorded driving pattern is met (as stored in the ECM). If another malfunction occurs while counting, the counter will reset.
- The DTC and the freeze frame data will be stored until the vehicle is driven 40 times (driving pattern A) without the same malfunction recurring (except for Misfire and Fuel Injection System). For Misfire and Fuel Injection System, the DTC and freeze frame data will be stored until the vehicle is driven 80 times (driving pattern C) without the same malfunction recurring. The "TIME" in "SELF-DIAGNOSTIC RESULTS" mode of CONSULT-II will count the number of times the vehicle is driven.
- The 1st trip DTC is not displayed when the self-diagnosis results in OK for the 2nd trip.

SUMMARY CHART

Items	Fuel Injection System	Misfire	Other
MIL (goes off)	3 (pattern B)	3 (pattern B)	3 (pattern B)
DTC, Freeze Frame Data (no display)	80 (pattern C)	80 (pattern C)	40 (pattern A)
1st Trip DTC (clear)	1 (pattern C), *1	1 (pattern C), *1	1 (pattern B)
1st Trip Freeze Frame Data (clear)	*1, *2	*1, *2	1 (pattern B)

For details about patterns B and C under "Fuel Injection System" and "Misfire", see [EC-70](#).

For details about patterns A and B under "Other", see [EC-72](#).

*1: Clear timing is at the moment OK is detected.

*2: Clear timing is when the same malfunction is detected in the 2nd trip.

ON BOARD DIAGNOSTIC (OBD) SYSTEM

RELATIONSHIP BETWEEN MIL, DTC, 1ST TRIP DTC AND DRIVING PATTERNS FOR "MISFIRE" <EXHAUST QUALITY DETERIORATION>, "FUEL INJECTION SYSTEM"

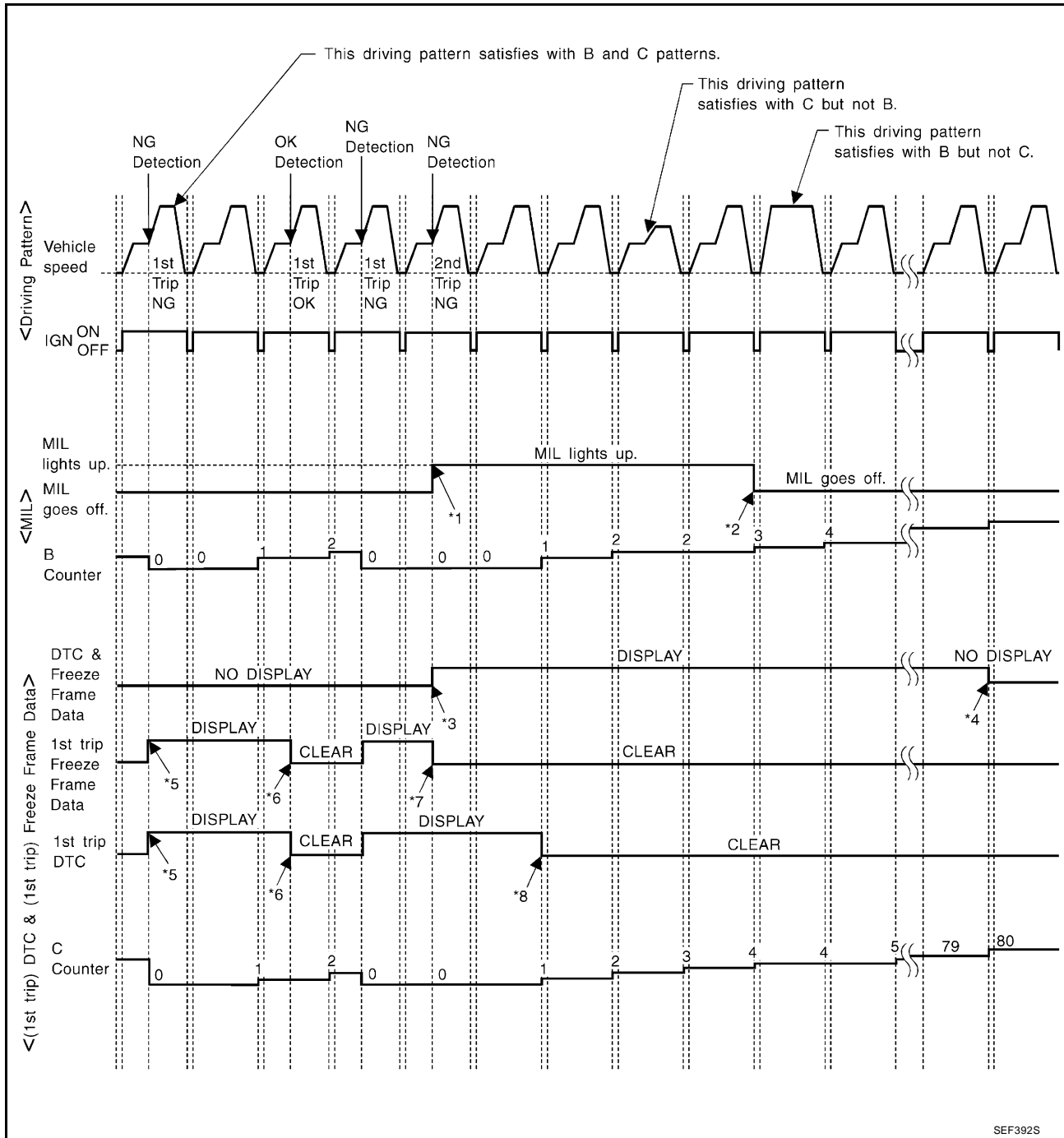

*1: When the same malfunction is detected in two consecutive trips, MIL will light up.

*2: MIL will go off after vehicle is driven 3 times (pattern B) without any malfunctions.

*3: When the same malfunction is detected in two consecutive trips, the DTC and the freeze frame data will be stored in ECM.

*4: The DTC and the freeze frame data will not be displayed any longer after vehicle is driven 80 times (pattern C) without the same malfunction. (The DTC and the freeze frame data still remain in ECM.)

*5: When a malfunction is detected for the first time, the 1st trip DTC and the 1st trip freeze frame data will be stored in ECM.

*6: The 1st trip DTC and the 1st trip freeze frame data will be cleared at the moment OK is detected.

*7: When the same malfunction is detected in the 2nd trip, the 1st trip freeze frame data will be cleared.

*8: 1st trip DTC will be cleared when vehicle is driven once (pattern C) without the same malfunction after DTC is stored in ECM.

ON BOARD DIAGNOSTIC (OBD) SYSTEM

EXPLANATION FOR DRIVING PATTERNS FOR “MISFIRE <EXHAUST QUALITY DETERIORATION>”, “FUEL INJECTION SYSTEM”

<Driving Pattern B>

Driving pattern B means the vehicle operation as follows:

All components and systems should be monitored at least once by the OBD system.

- The B counter will be cleared when the malfunction is detected once regardless of the driving pattern.
- The B counter will be counted up when driving pattern B is satisfied without any malfunction.
- The MIL will go off when the B counter reaches 3. (*2 in OBD SYSTEM OPERATION CHART)

<Driving Pattern C>

Driving pattern C means the vehicle operation as follows:

The following conditions should be satisfied at the same time:

Engine speed: (Engine speed in the freeze frame data) ± 375 rpm

Calculated load value: (Calculated load value in the freeze frame data) $\times (1 \pm 0.1)$ [%]

Engine coolant temperature (T) condition:

- When the freeze frame data shows lower than 70°C (158°F), T should be lower than 70°C (158°F).
- When the freeze frame data shows higher than or equal to 70°C (158°F), T should be higher than or equal to 70°C (158°F).

Example:

If the stored freeze frame data is as follows:

Engine speed: 850 rpm, Calculated load value: 30%, Engine coolant temperature: 80°C (176°F)

To be satisfied with driving pattern C, the vehicle should run under the following conditions:

Engine speed: 475 - 1,225 rpm, Calculated load value: 27 - 33%, Engine coolant temperature: more than 70°C (158°F)

- The C counter will be cleared when the malfunction is detected regardless of vehicle conditions above.
- The C counter will be counted up when vehicle conditions above is satisfied without the same malfunction.
- The DTC will not be displayed after C counter reaches 80.
- The 1st trip DTC will be cleared when C counter is counted once without the same malfunction after DTC is stored in ECM.

ON BOARD DIAGNOSTIC (OBD) SYSTEM

RELATIONSHIP BETWEEN MIL, DTC, 1ST TRIP DTC AND DRIVING PATTERNS EXCEPT FOR "MISFIRE <EXHAUST QUALITY DETERIORATION>", "FUEL INJECTION SYSTEM"

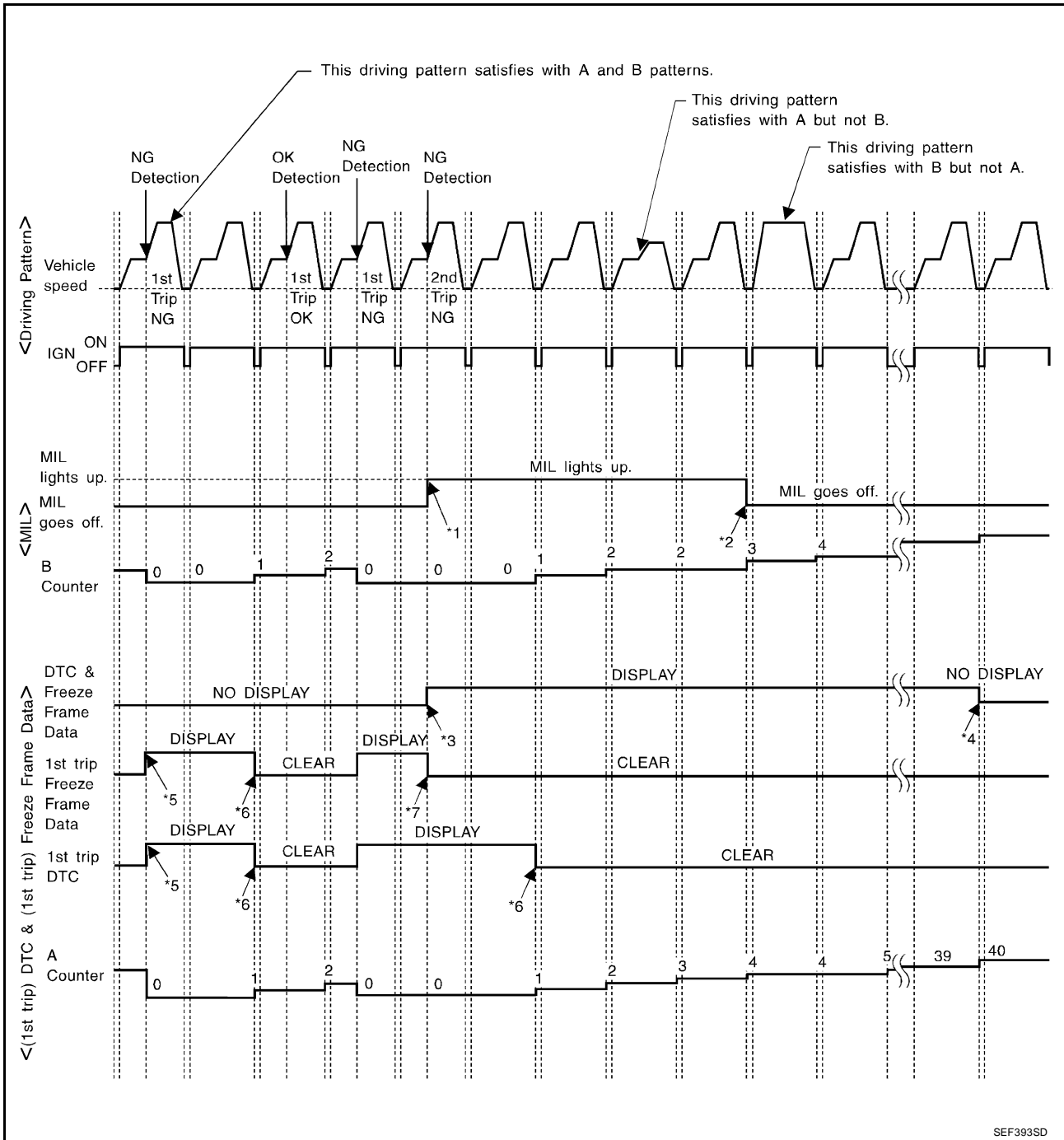

*1: When the same malfunction is detected in two consecutive trips, MIL will light up.

*2: MIL will go off after vehicle is driven 3 times (pattern B) without any malfunctions.

*3: When the same malfunction is detected in two consecutive trips, the DTC and the freeze frame data will be stored in ECM.

*4: The DTC and the freeze frame data will not be displayed any longer after vehicle is driven 40 times (pattern A) without the same malfunction. (The DTC and the freeze frame data still remain in ECM.)

*5: When a malfunction is detected for the first time, the 1st trip DTC and the 1st trip freeze frame data will be stored in ECM.

*6: 1st trip DTC will be cleared after vehicle is driven once (pattern B) without the same malfunction.

When the same malfunction is detected in the 2nd trip, the 1st trip freeze frame data will be cleared.

ON BOARD DIAGNOSTIC (OBD) SYSTEM

EXPLANATION FOR DRIVING PATTERNS EXCEPT FOR "MISFIRE <EXHAUST QUALITY DETERIORATION>", "FUEL INJECTION SYSTEM"

<Driving Pattern A>

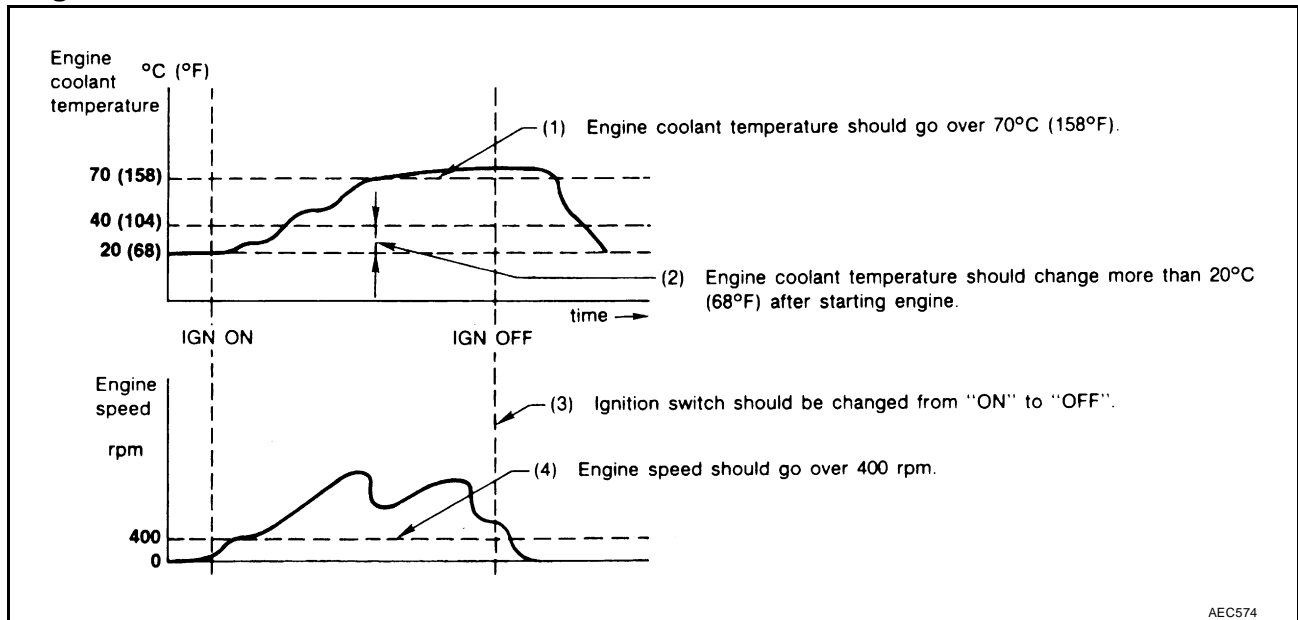

- The A counter will be cleared when the malfunction is detected regardless of (1) - (4).
- The A counter will be counted up when (1) - (4) are satisfied without the same malfunction.
- The DTC will not be displayed after the A counter reaches 40.

<Driving Pattern B>

Driving pattern B means the vehicle operation as follows:

All components and systems should be monitored at least once by the OBD system.

- The B counter will be cleared when the malfunction is detected once regardless of the driving pattern.
- The B counter will be counted up when driving pattern B is satisfied without any malfunctions.
- The MIL will go off when the B counter reaches 3 (*2 in OBD SYSTEM OPERATION CHART).

BASIC SERVICE PROCEDURE

BASIC SERVICE PROCEDURE

PFP:00018

Basic Inspection

UBS00P1D

1. INSPECTION START

1. Check service records for any recent repairs that may indicate a related malfunction, or a current need for scheduled maintenance.
2. Open engine hood and check the following:
 - Harness connectors for improper connections
 - Wiring harness for improper connections, pinches and cut
 - Vacuum hoses for splits, kinks and improper connections
 - Hoses and ducts for leaks
 - Air cleaner clogging
 - Gasket
3. Confirm that electrical or mechanical loads are not applied.
 - Headlamp switch is OFF.
 - Air conditioner switch is OFF.
 - Rear window defogger switch is OFF.
 - Steering wheel is in the straight-ahead position, etc.
4. Start engine and warm it up until engine coolant temperature indicator points the middle of gauge. Ensure engine stays below 1,000 rpm.

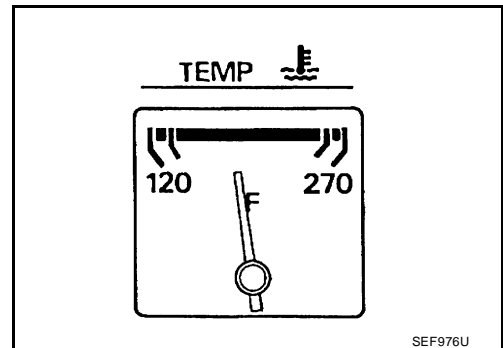
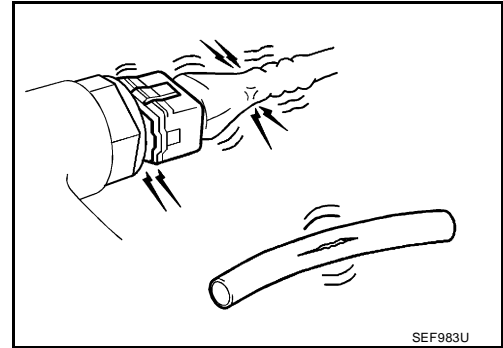

5. Run engine at about 2,000 rpm for about 2 minutes under no load.
6. Make sure that no DTC is displayed with CONSULT-II or GST.

OK or NG

- OK >> GO TO 3.
NG >> GO TO 2.

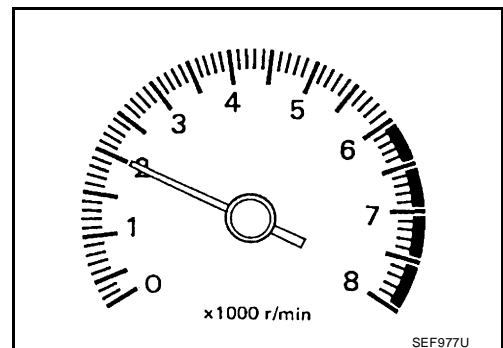

2. REPAIR OR REPLACE

Repair or replace components as necessary according to corresponding Diagnostic Procedure.

>> GO TO 3.

BASIC SERVICE PROCEDURE

3. CHECK TARGET IDLE SPEED

④ With CONSULT-II

1. Run engine at about 2,000 rpm for about 2 minutes under no load.
2. Rev engine (2,000 to 3,000 rpm) two or three times under no load, then run engine at idle speed for about 1 minute.

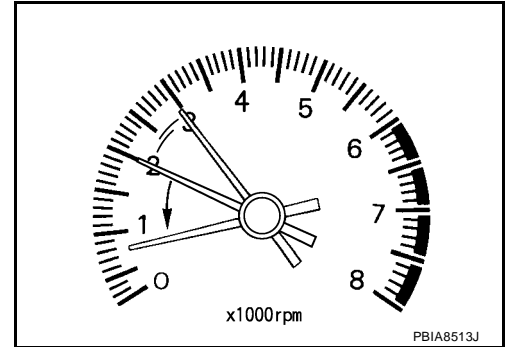

3. Read idle speed in "DATA MONITOR" mode with CONSULT-II. Refer to [EC-78, "IDLE SPEED"](#) .

675 ± 50 rpm (in P or N position)

DATA MONITOR	
MONITOR	NO DTC
ENG SPEED	XXX rpm

SEF058Y

⊗ Without CONSULT-II

1. Run engine at about 2,000 rpm for about 2 minutes under no load.
2. Rev engine (2,000 to 3,000 rpm) two or three times under no load, then run engine at idle speed for about 1 minute.
3. Check idle speed. Refer to [EC-78, "IDLE SPEED"](#) .

675 ± 50 rpm (in P or N position)

OK or NG

- OK >> GO TO 10.
NG >> GO TO 4.

4. PERFORM ACCELERATOR PEDAL RELEASED POSITION LEARNING

1. Stop engine.
2. Perform [EC-80, "Accelerator Pedal Released Position Learning"](#) .

>> GO TO 5.

5. PERFORM THROTTLE VALVE CLOSED POSITION LEARNING

Perform [EC-80, "Throttle Valve Closed Position Learning"](#) .

>> GO TO 6.

BASIC SERVICE PROCEDURE

6. PERFORM IDLE AIR VOLUME LEARNING

Refer to [EC-80, "Idle Air Volume Learning"](#) .

Is Idle Air Volume Learning carried out successfully?

Yes or No

Yes >> GO TO 7.

No >> 1. Follow the instruction of Idle Air Volume Learning.
2. GO TO 4.

7. CHECK TARGET IDLE SPEED AGAIN

With CONSULT-II

1. Start engine and warm it up to normal operating temperature.
2. Read idle speed in "DATA MONITOR" mode with CONSULT-II.
Refer to [EC-78, "IDLE SPEED"](#) .

675 ± 50 rpm (in P or N position)

Without CONSULT-II

1. Start engine and warm it up to normal operating temperature.
2. Check idle speed. Refer to [EC-78, "IDLE SPEED"](#) .

675 ± 50 rpm (in P or N position)

OK or NG

OK >> GO TO 10.

NG >> GO TO 8.

DATA MONITOR	
MONITOR	NO DTC
ENG SPEED	XXX rpm
COOLAN TEMP/S	XXX °C

SEF174Y

8. DETECT MALFUNCTIONING PART

Check the following.

- Check camshaft position sensor (PHASE) and circuit. Refer to [EC-387](#) .
- Check crankshaft position sensor (POS) and circuit. Refer to [EC-379](#) .

OK or NG

OK >> GO TO 9.

NG >> 1. Repair or replace.
2. GO TO 4.

9. CHECK ECM FUNCTION

1. Substitute another known-good ECM to check ECM function. (ECM may be the cause of an incident, but this is a rare case.)
2. Perform initialization of NVIS (NATS) system and registration of all NVIS (NATS) ignition key IDs. Refer to [BL-203, "NVIS\(NISSAN Vehicle Immobilizer System-NATS\)"](#) .

>> GO TO 4.

BASIC SERVICE PROCEDURE

10. CHECK IGNITION TIMING

1. Run engine at idle.
2. Check ignition timing with a timing light.
Refer to [EC-78, "IGNITION TIMING"](#) .

15 ± 5° BTDC (in P or N position)

OK or NG

- OK >> GO TO 19.
NG >> GO TO 11.

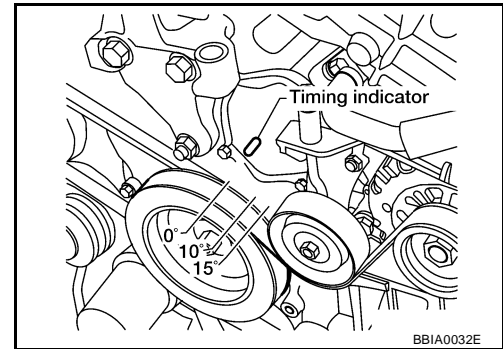

11. PERFORM ACCELERATOR PEDAL RELEASED POSITION LEARNING

1. Stop engine.
2. Perform [EC-80, "Accelerator Pedal Released Position Learning"](#) .

>> GO TO 12.

12. PERFORM THROTTLE VALVE CLOSED POSITION LEARNING

Perform [EC-80, "Throttle Valve Closed Position Learning"](#) .

>> GO TO 13.

13. PERFORM IDLE AIR VOLUME LEARNING

Refer to [EC-80, "Idle Air Volume Learning"](#) .

Is Idle Air Volume Learning carried out successfully?

Yes or No

- Yes >> GO TO 14.
No >> 1. Follow the instruction of Idle Air Volume Learning.
2. GO TO 4.

14. CHECK TARGET IDLE SPEED AGAIN

Ⓟ With CONSULT-II

1. Start engine and warm it up to normal operating temperature.
2. Read idle speed in "DATA MONITOR" mode with CONSULT-II.
Refer to [EC-78, "IDLE SPEED"](#) .

675 ± 50 rpm (in P or N position)

ⓧ Without CONSULT-II

1. Start engine and warm it up to normal operating temperature.
2. Check idle speed. Refer to [EC-78, "IDLE SPEED"](#) .

675 ± 50 rpm (in P or N position)

OK or NG

- OK >> GO TO 15.
NG >> GO TO 17.

DATA MONITOR	
MONITOR	NO DTC
ENG SPEED	XXX rpm
COOLANT TEMP/S	XXX °C

SEF174Y

BASIC SERVICE PROCEDURE

15. CHECK IGNITION TIMING AGAIN

1. Run engine at idle.
2. Check ignition timing with a timing light.
Refer to [EC-78, "IGNITION TIMING"](#).

15 ± 5° BTDC (in P or N position)

OK or NG

- OK >> GO TO 19.
NG >> GO TO 16.

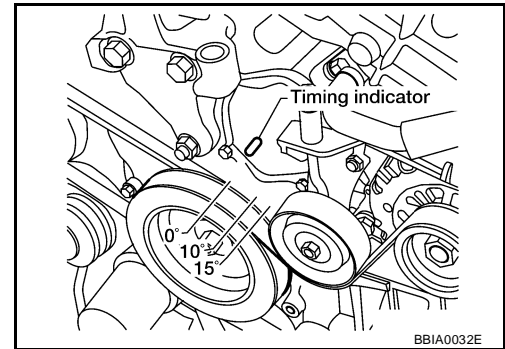

16. CHECK TIMING CHAIN INSTALLATION

Check timing chain installation. Refer to [EM-56, "TIMING CHAIN"](#).

OK or NG

- OK >> GO TO 17.
NG >> 1. Repair the timing chain installation.
2. GO TO 4.

17. DETECT MALFUNCTIONING PART

Check the following.

- Check camshaft position sensor (PHASE) and circuit. Refer to [EC-387](#).
- Check crankshaft position sensor (POS) and circuit. Refer to [EC-379](#).

OK or NG

- OK >> GO TO 18.
NG >> 1. Repair or replace.
2. GO TO 4.

18. CHECK ECM FUNCTION

1. Substitute another known-good ECM to check ECM function. (ECM may be the cause of an incident, but this is a rare case.)
2. Perform initialization of NVIS (NATS) system and registration of all NVIS (NATS) ignition key IDs. Refer to [BL-203, "NVIS\(NISSAN Vehicle Immobilizer System-NATS\)"](#).

>> GO TO 4.

19. INSPECTION END

Did you replace the ECM, referring this Basic Inspection procedure?

Yes or No

- Yes >> 1. Perform [EC-79, "VIN Registration"](#).
2. **INSPECTION END**
- No >> **INSPECTION END**

BASIC SERVICE PROCEDURE

UBS00P1E

Idle Speed and Ignition Timing Check

IDLE SPEED

With CONSULT-II

Check idle speed in "DATA MONITOR" mode with CONSULT-II.

DATA MONITOR	
MONITOR	NO DTC
ENG SPEED	XXX rpm

SEF058Y

With GST

Check idle speed with GST.

IGNITION TIMING

Any of following two methods may be used.

Method A

1. Slide the harness protector off ignition coil No.1 to clear the wires.
2. Attach timing light to the ignition coil No.1 wires as shown in the figure.

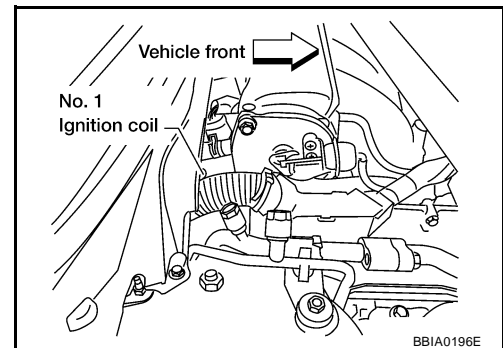

3. Check ignition timing.

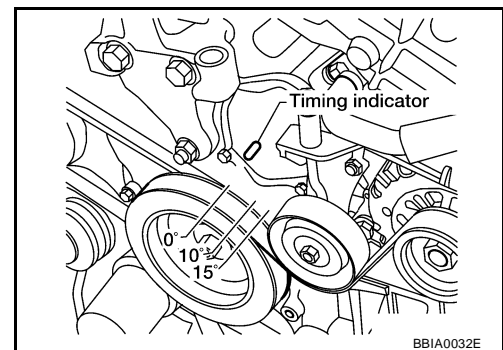

Method B

1. Remove No.1 ignition coil.

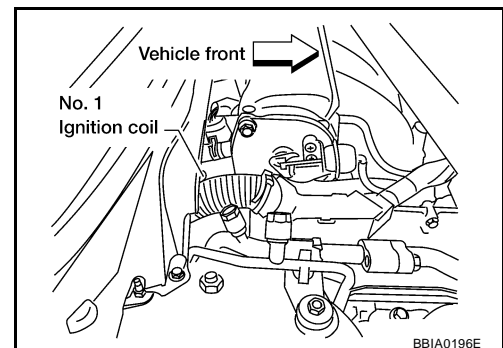

BASIC SERVICE PROCEDURE

2. Connect No.1 ignition coil and spark plug with suitable high-tension wire as shown, and attach timing light clamp to this wire.

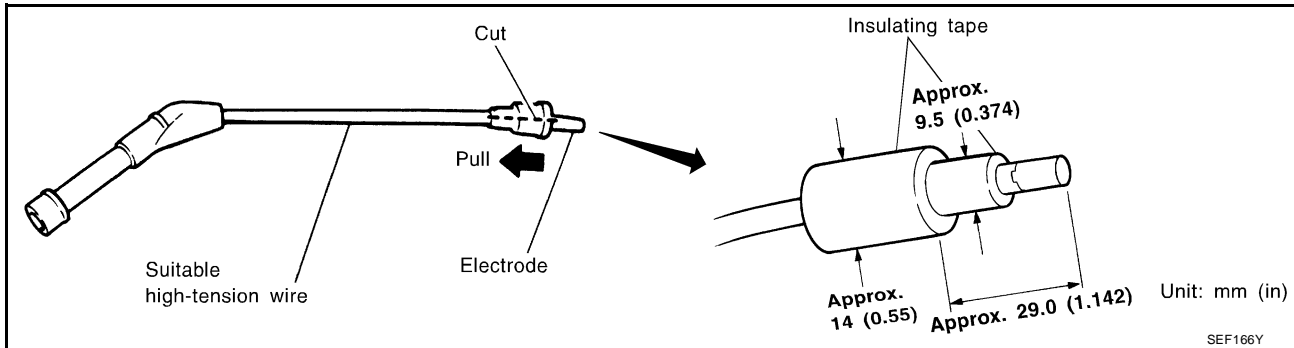
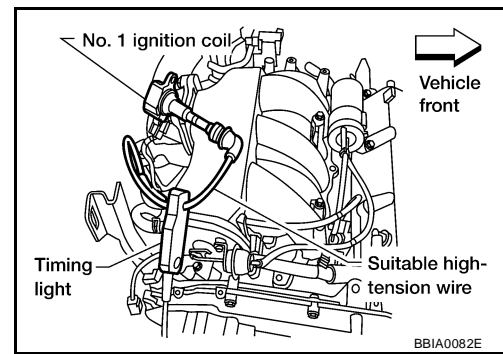

3. Check ignition timing.

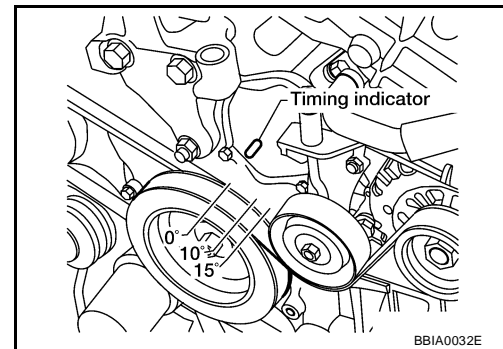

Procedure After Replacing ECM

UBS00QA8

When replacing ECM, the following procedure must be performed.

1. Perform initialization of NVIS (NATS) system and registration of all NVIS (NATS) ignition key IDs. Refer to [BL-205, "ECM Re-communicating Function"](#).
2. Perform [EC-79, "VIN Registration"](#).
3. Perform [EC-80, "Accelerator Pedal Released Position Learning"](#).
4. Perform [EC-80, "Throttle Valve Closed Position Learning"](#).
5. Perform [EC-80, "Idle Air Volume Learning"](#).

VIN Registration

UBS00P1F

DESCRIPTION

VIN Registration is an operation to registering VIN in ECM. It must be performed each time ECM is replaced.

NOTE:

Accurate VIN which is registered in ECM may be required for Inspection & Maintenance (I/M).

OPERATION PROCEDURE

Ⓟ With CONSULT-II

1. Check the VIN of the vehicle and note it. Refer to [GI-47, "IDENTIFICATION INFORMATION"](#).
2. Turn ignition switch ON and engine stopped.

BASIC SERVICE PROCEDURE

3. Select "VIN REGISTRATION" in "WORK SUPPORT" mode.
4. Follow the instruction of CONSULT-II display.

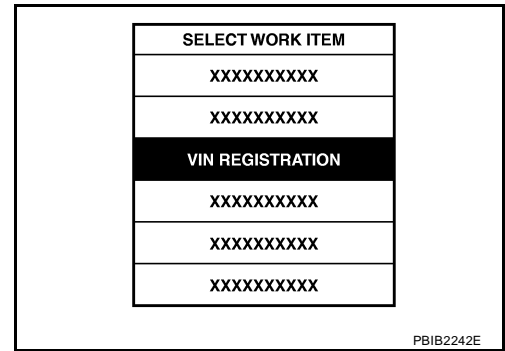

Accelerator Pedal Released Position Learning DESCRIPTION

UBS00P1G

Accelerator Pedal Released Position Learning is an operation to learn the fully released position of the accelerator pedal by monitoring the accelerator pedal position sensor output signal. It must be performed each time harness connector of accelerator pedal position sensor or ECM is disconnected.

OPERATION PROCEDURE

1. Make sure that accelerator pedal is fully released.
2. Turn ignition switch ON and wait at least 2 seconds.
3. Turn ignition switch OFF and wait at least 10 seconds.
4. Turn ignition switch ON and wait at least 2 seconds.
5. Turn ignition switch OFF and wait at least 10 seconds.

Throttle Valve Closed Position Learning DESCRIPTION

UBS00P1H

Throttle Valve Closed Position Learning is an operation to learn the fully closed position of the throttle valve by monitoring the throttle position sensor output signal. It must be performed each time harness connector of electric throttle control actuator or ECM is disconnected.

OPERATION PROCEDURE

1. Make sure that accelerator pedal is fully released.
2. Turn ignition switch ON.
3. Turn ignition switch OFF and wait at least 10 seconds.
Make sure that throttle valve moves during above 10 seconds by confirming the operating sound.

Idle Air Volume Learning DESCRIPTION

UBS00P1I

Idle Air Volume Learning is an operation to learn the idle air volume that keeps each engine within the specific range. It must be performed under any of the following conditions:

- Each time electric throttle control actuator or ECM is replaced.
- Idle speed or ignition timing is out of specification.

PREPARATION

Before performing Idle Air Volume Learning, make sure that all of the following conditions are satisfied. Learning will be cancelled if any of the following conditions are missed for even a moment.

- Battery voltage: More than 12.9V (At idle)
- Engine coolant temperature: 70 - 100°C (158 - 212°F)
- PNP switch: ON
- Electric load switch: OFF
(Air conditioner, headlamp, rear window defogger)

On vehicles equipped with daytime light systems, if the parking brake is applied before the engine is start the headlamp will not be illuminated.

- Steering wheel: Neutral (Straight-ahead position)
- Vehicle speed: Stopped
- Transmission: Warmed-up

BASIC SERVICE PROCEDURE

- With CONSULT-II: Drive vehicle until "FLUID TEMP SE" in "DATA MONITOR" mode of "A/T" system indicates less than 0.9V.
- Without CONSULT-II: Drive vehicle for 10 minutes.

OPERATION PROCEDURE

With CONSULT-II

1. Perform [EC-80, "Accelerator Pedal Released Position Learning"](#).
2. Perform [EC-80, "Throttle Valve Closed Position Learning"](#).
3. Start engine and warm it up to normal operating temperature.
4. Check that all items listed under the topic PREPARATION (previously mentioned) are in good order.
5. Select "IDLE AIR VOL LEARN" in "WORK SUPPORT" mode.

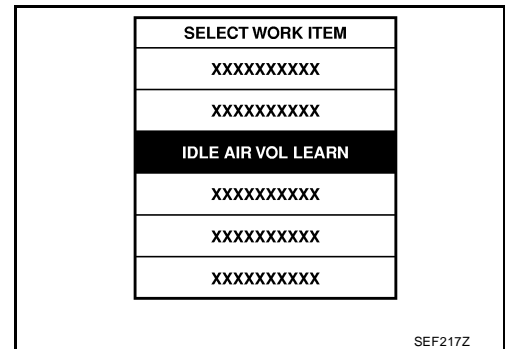

6. Touch "START" and wait 20 seconds.

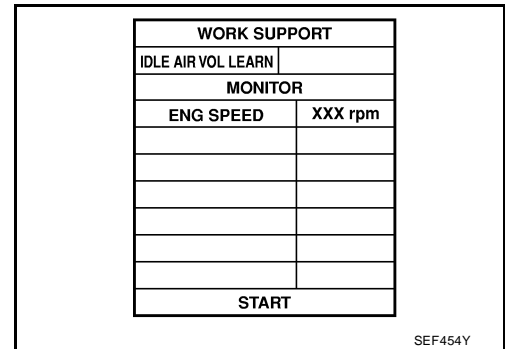

7. Make sure that "CMPLT" is displayed on CONSULT-II screen. If "CMPLT" is not displayed, Idle Air Volume Learning will not be carried out successfully. In this case, find the cause of the incident by referring to the Diagnostic Procedure below.
8. Rev up the engine two or three times and make sure that idle speed and ignition timing are within the specifications.

ITEM	SPECIFICATION
Idle speed	675 ± 50 rpm (in P or N position)
Ignition timing	15 ± 5° BTDC (in P or N position)

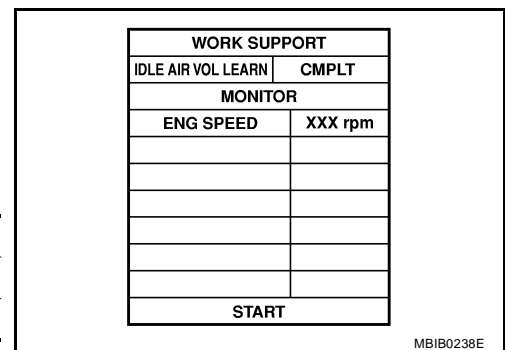

Without CONSULT-II

NOTE:

- It is better to count the time accurately with a clock.
- It is impossible to switch the diagnostic mode when an accelerator pedal position sensor circuit has a malfunction.

1. Perform [EC-80, "Accelerator Pedal Released Position Learning"](#).
2. Perform [EC-80, "Throttle Valve Closed Position Learning"](#).
3. Start engine and warm it up to normal operating temperature.
4. Check that all items listed under the topic PREPARATION (previously mentioned) are in good order.
5. Turn ignition switch OFF and wait at least 10 seconds.

BASIC SERVICE PROCEDURE

6. Confirm that accelerator pedal is fully released, turn ignition switch ON and wait 3 seconds.
7. Repeat the following procedure quickly five times within 5 seconds.
 - a. Fully depress the accelerator pedal.
 - b. Fully release the accelerator pedal.
8. Wait 7 seconds, fully depress the accelerator pedal and keep it for approx. 20 seconds until the MIL stops blinking and turned ON.
9. Fully release the accelerator pedal within 3 seconds after the MIL turned ON.
10. Start engine and let it idle.
11. Wait 20 seconds.

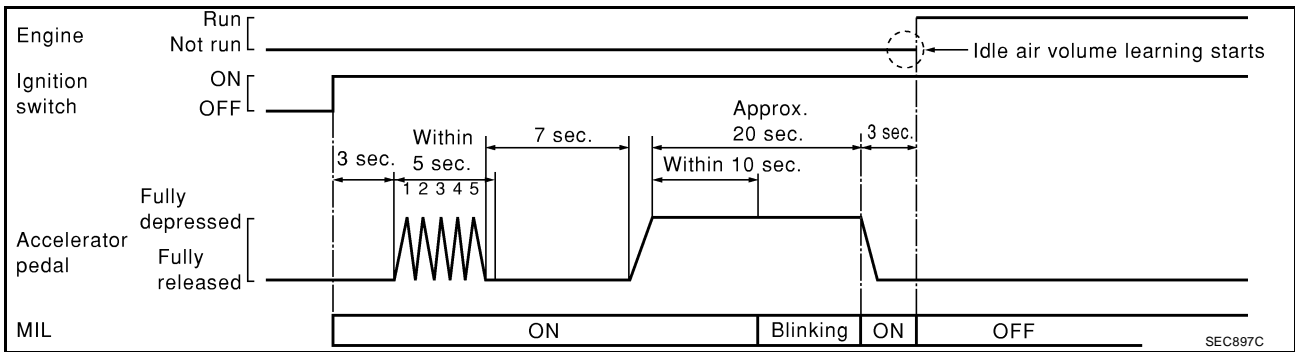

12. Rev up the engine two or three times and make sure that idle speed and ignition timing are within the specifications.

ITEM	SPECIFICATION
Idle speed	675 ± 50 rpm (in P or N position)
Ignition timing	15 ± 5° BTDC (in P or N position)

13. If idle speed and ignition timing are not within the specification, Idle Air Volume Learning will not be carried out successfully. In this case, find the cause of the incident by referring to the DIAGNOSTIC PROCEDURE below.

DIAGNOSTIC PROCEDURE

If idle air volume learning cannot be performed successfully, proceed as follows:

1. Check that throttle valve is fully closed.
2. Check PCV valve operation.
3. Check that downstream of throttle valve is free from air leakage.
4. When the above three items check out OK, engine component parts and their installation condition are questionable. Check and eliminate the cause of the incident.
It is useful to perform [EC-139, "TROUBLE DIAGNOSIS - SPECIFICATION VALUE"](#).
5. If any of the following conditions occur after the engine has started, eliminate the cause of the incident and perform Idle Air Volume Learning all over again:
 - Engine stalls.
 - Erroneous idle.

Fuel Pressure Check FUEL PRESSURE RELEASE

UBS00P1J

Ⓜ With CONSULT-II

1. Turn ignition switch ON.

BASIC SERVICE PROCEDURE

2. Perform "FUEL PRESSURE RELEASE" in "WORK SUPPORT" mode with CONSULT-II.
3. Start engine.
4. After engine stalls, crank it two or three times to release all fuel pressure.
5. Turn ignition switch OFF.

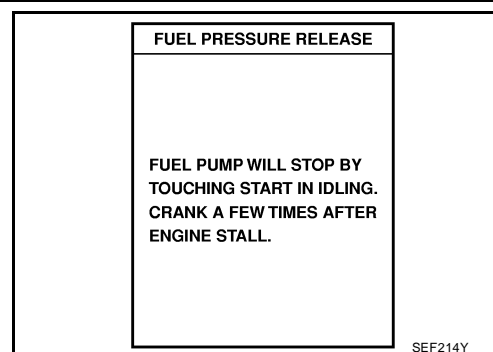

⊗ Without CONSULT-II

1. Remove fuel pump fuse located in IPDM E/R.
2. Start engine.
3. After engine stalls, crank it two or three times to release all fuel pressure.
4. Turn ignition switch OFF.
5. Reinstall fuel pump fuse after servicing fuel system.

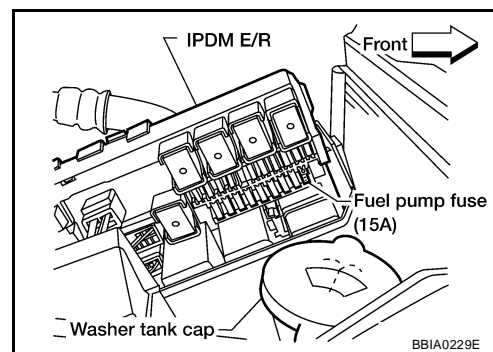

FUEL PRESSURE CHECK

CAUTION:

Before disconnecting fuel line, release fuel pressure from fuel line to eliminate danger.

NOTE:

Prepare pans or saucers under the disconnected fuel line because the fuel may spill out. The fuel pressure cannot be completely released because V42 models do not have fuel return system.

Method A

CAUTION:

- The fuel hose connection method used when taking fuel pressure check must not be used for other purposes.
 - Be careful not to scratch or put debris around connection area when servicing, so that the quick connector maintains sealability with O-rings inside.
1. Release fuel pressure to zero. Refer to [EC-82, "FUEL PRESSURE RELEASE"](#).
 2. Prepare fuel hose for fuel pressure check, and connect fuel pressure gauge.
 - Use suitable fuel hose for fuel pressure check (genuine NISSAN fuel hose without quick connector).
 - To avoid unnecessary force or tension to hose, use moderately long fuel hose for fuel pressure check.
 - Do not use the fuel hose for checking fuel pressure with damage or cracks on it.
 - Use Pressure Gauge to check fuel pressure.
 3. Remove fuel hose. Refer to [EM-24, "INTAKE MANIFOLD"](#).
 - Do not twist or kink fuel hose because it is plastic hose.
 - Do not remove fuel hose from quick connector.
 - Keep the original fuel hose to be free from intrusion of dust or foreign substances with a suitable cover.

BASIC SERVICE PROCEDURE

4. Install the fuel pressure gauge as shown in the figure.
 - Wipe off oil or dirt from hose insertion part using cloth moistened with gasoline.
 - Apply proper amount of gasoline between top of the fuel tube and No.1 spool.
 - Insert fuel hose for fuel pressure check until it touches the No.1 spool on fuel tube.
 - Use NISSAN genuine hose clamp (part number: 16439 N4710 or 16439 40U00).
 - When reconnecting fuel line, always use new clamps.
 - When reconnecting fuel hose, check the original fuel hose for damage and abnormality.
 - Use a torque driver to tighten clamps.
 - Install hose clamp to the position within 1 - 2 mm (0.04 - 0.08in).

Tightening torque: 1 - 1.5 Nm (0.1 - 0.15 kg-m, 9 - 13in-lb)

- Make sure that clamp screw does not contact adjacent parts.

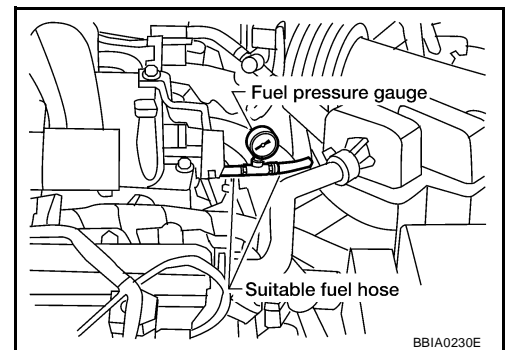
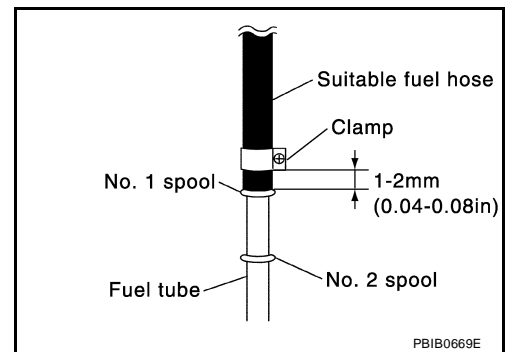

5. After connecting fuel hose for fuel pressure check, pull the hose with a force of approximately 98 N (10 kg, 22lb) to confirm fuel tube does not come off.
6. Turn ignition switch ON and check for fuel leakage.
7. Start engine and check for fuel leakage.
8. Read the indication of fuel pressure gauge.
 - Do not perform fuel pressure check with system operating. Fuel pressure gauge may indicate false readings.
 - During fuel pressure check, confirm for fuel leakage from fuel connection every 3 minutes.

At idling: Approximately 350 kPa (3.57 kg/cm² , 51 psi)

9. If result is unsatisfactory, go to next step.
10. Check the following.
 - Fuel hoses and fuel tubes for clogging
 - Fuel filter for clogging
 - Fuel pump
 - Fuel pressure regulator for cloggingIf OK, replace fuel pressure regulator.
If NG, repair or replace.

Method B

CAUTION:

- Be careful not to scratch or get the fuel hose connection area dirty when servicing, so that the quick connector o-ring maintains sealability.
 - Use Fuel Pressure Gauge Kit J-44321 and Fuel Pressure Adapter J-44321-6 to check fuel pressure.
1. Release fuel pressure to zero. Refer to [EC-82, "FUEL PRESSURE RELEASE"](#).
 2. Remove fuel hose using Quick Connector Release J-45488. Refer to [EM-40, "FUEL INJECTOR AND FUEL TUBE"](#).
 - Do not twist or kink fuel hose because it is plastic hose.
 - Do not remove fuel hose from quick connector.

BASIC SERVICE PROCEDURE

-
- Keep fuel hose connections clean.
 3. Install Fuel Pressure Adapter J-44321-6 and Fuel Pressure Gauge (from kit J-44321) as shown in figure.
 - Do not distort or bend fuel rail tube when installing fuel pressure gauge adapter.
 - When reconnecting fuel hose, check the original fuel hose for damage and abnormality.
 4. Turn ignition switch ON (reactivate fuel pump), and check for fuel leakage.
 5. Start engine and check for fuel leakage.
 6. Read the indication of fuel pressure gauge.
 - During fuel pressure check, check for fuel leakage from fuel connection every 3 minutes.

At idling: Approximately 350 kPa (3.57 kg/cm² , 51 psi)
 7. If result is unsatisfactory, go to next step.
 8. Check the following.
 - Fuel hoses and fuel tubes for clogging
 - Fuel filter for clogging
 - Fuel pump
 - Fuel pressure regulator for cloggingIf OK, replace fuel pressure regulator.
If NG, repair or replace.
 9. Before disconnecting Fuel Pressure Gauge and Fuel Pressure Adapter J-44321-6, release fuel pressure to zero. Refer to [EC-82, "FUEL PRESSURE RELEASE"](#)

A

EC

C

D

E

F

G

H

I

J

K

L

M

TROUBLE DIAGNOSIS

PFP:00004

Trouble Diagnosis Introduction INTRODUCTION

UBS00P1K

The engine has an ECM to control major systems such as fuel control, ignition control, idle air control system, etc. The ECM accepts input signals from sensors and instantly drives actuators. It is essential that both input and output signals are proper and stable. At the same time, it is important that there are no malfunctions such as vacuum leaks, fouled spark plugs, or other malfunctions with the engine.

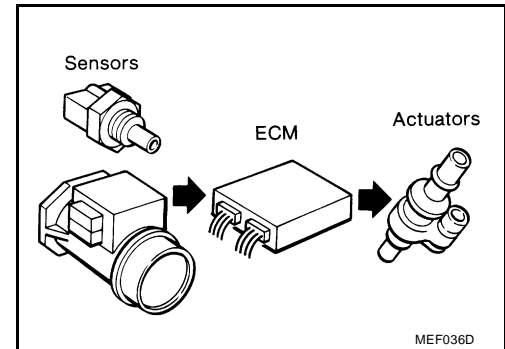

It is much more difficult to diagnose an incident that occurs intermittently rather than continuously. Most intermittent incidents are caused by poor electric connections or improper wiring. In this case, careful checking of suspected circuits may help prevent the replacement of good parts.

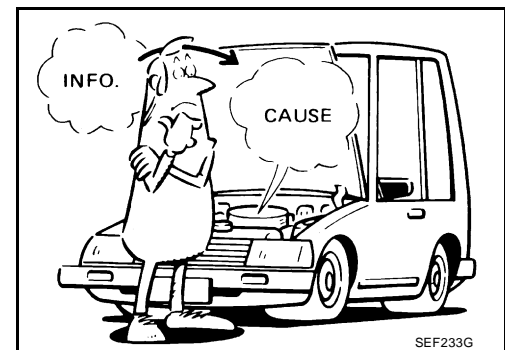

A visual check only may not find the cause of the incidents. A road test with CONSULT-II (or GST) or a circuit tester connected should be performed. Follow the Work Flow on [EC-87](#).

Before undertaking actual checks, take a few minutes to talk with a customer who approaches with a driveability complaint. The customer can supply good information about such incidents, especially intermittent ones. Find out what symptoms are present and under what conditions they occur. A Diagnostic Worksheet like the example on [EC-91](#) should be used.

Start your diagnosis by looking for conventional malfunctions first. This will help troubleshoot driveability malfunctions on an electronically controlled engine vehicle.

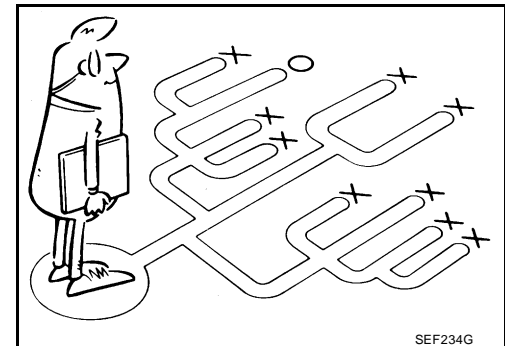

TROUBLE DIAGNOSIS

WORK FLOW Overall Sequence

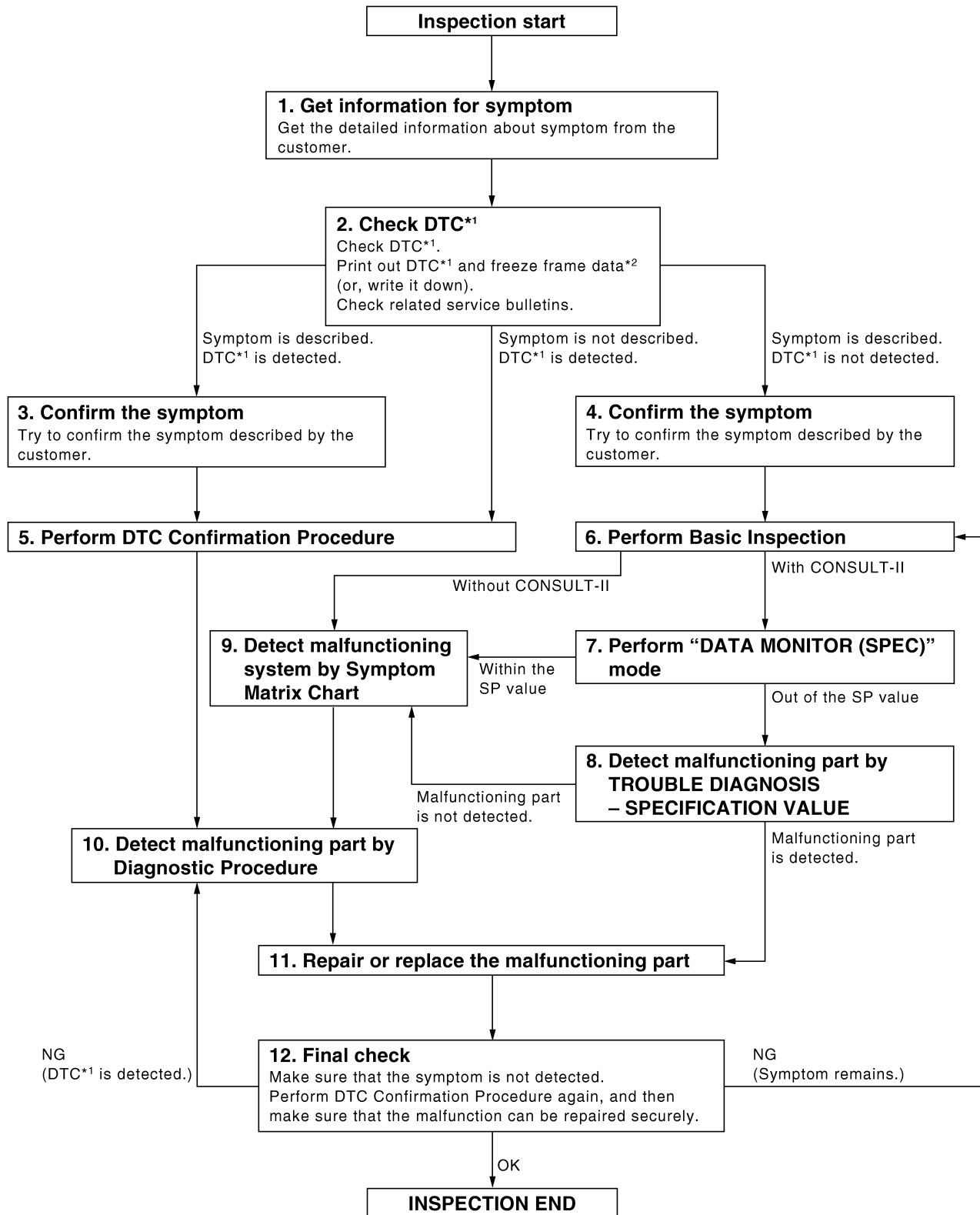

*1: Include 1st trip DTC.

*2: Include 1st trip freeze frame data.

PBIB2267E

TROUBLE DIAGNOSIS

Detailed Flow

1. GET INFORMATION FOR SYMPTOM

Get the detailed information from the customer about the symptom (the condition and the environment when the incident/malfunction occurred) using the [EC-90, "DIAGNOSTIC WORKSHEET"](#) .

>> GO TO 2.

2. CHECK DTC*¹

1. Check DTC*¹ .
2. Perform the following procedure if DTC*¹ is displayed.
 - Record DTC*¹ and freeze frame data*² . (Print them out with CONSULT-II or GST.)
 - Erase DTC*¹ . (Refer to [EC-63, "HOW TO ERASE EMISSION-RELATED DIAGNOSTIC INFORMATION"](#) .)
 - Study the relationship between the cause detected by DTC*¹ and the symptom described by the customer. (Symptom Matrix Chart is useful. Refer to [EC-95, "Symptom Matrix Chart"](#) .)
3. Check related service bulletins for information.

Is any symptom described and any DTC detected?

Symptom is described, DTC*¹ is displayed>>GO TO 3.

Symptom is described, DTC*¹ is not displayed>>GO TO 4.

Symptom is not described, DTC*¹ is displayed>>GO TO 5.

3. CONFIRM THE SYMPTOM

Try to confirm the symptom described by the customer (except MIL ON).

DIAGNOSIS WORK SHEET is useful to verify the incident.

Connect CONSULT-II to the vehicle in "DATA MONITOR (AUTO TRIG)" mode and check real time diagnosis results.

Verify relation between the symptom and the condition when the symptom is detected.

>> GO TO 5.

4. CONFIRM THE SYMPTOM

Try to confirm the symptom described by the customer.

DIAGNOSIS WORK SHEET is useful to verify the incident.

Connect CONSULT-II to the vehicle in "DATA MONITOR (AUTO TRIG)" mode and check real time diagnosis results.

Verify relation between the symptom and the condition when the symptom is detected.

>> GO TO 6.

TROUBLE DIAGNOSIS

5. PERFORM DTC CONFIRMATION PROCEDURE

Perform DTC Confirmation Procedure for the displayed DTC*¹, and then make sure that DTC*¹ is detected again.

At this time, always connect CONSULT-II to the vehicle, and check diagnostic results in real time on "DATA MONITOR (AUTO TRIG)".

If two or more DTCs*¹ are detected, refer to [EC-92, "DTC Inspection Priority Chart"](#) and determine trouble diagnosis order.

NOTE:

- Freeze frame data*² is useful if the DTC*¹ is not detected.
- Perform Overall Function Check if DTC Confirmation Procedure is not included on Service Manual. This simplified check procedure is an effective alternative though DTC*¹ cannot be detected during this check. If the result of Overall Function Check is NG, it is the same as the detection of DTC*¹ by DTC Confirmation Procedure.

Is DTC*¹ detected?

Yes >> GO TO 10.

No >> Check according to [EC-149, "TROUBLE DIAGNOSIS FOR INTERMITTENT INCIDENT"](#).

6. PERFORM BASIC INSPECTION

Perform [EC-73, "Basic Inspection"](#).

With CONSULT-II>>GO TO 7.

Without CONSULT-II>>GO TO 9.

7. PERFORM DATA MONITOR (SPEC) MODE

With CONSULT-II

Make sure that "MAS A/F SE-B1", "B/FUEL SCHDL", and "A/F ALPHA-B1", "A/F ALPHA-B2" are within the SP value using CONSULT-II "DATA MONITOR (SPEC)" mode. Refer to [EC-139, "TROUBLE DIAGNOSIS - SPECIFICATION VALUE"](#).

Are they within the SP value?

Yes >> GO TO 9.

No >> GO TO 8.

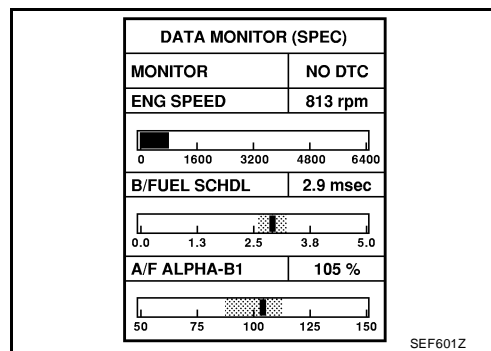

8. DETECT MALFUNCTIONING PART BY TROUBLE DIAGNOSIS - SPECIFICATION VALUE

Detect malfunctioning part according to [EC-140, "Diagnostic Procedure"](#).

Is malfunctioning part detected?

Yes >> GO TO 11.

No >> GO TO 9.

9. DETECT MALFUNCTIONING SYSTEM BY SYMPTOM MATRIX CHART

Detect malfunctioning system according to [EC-95, "Symptom Matrix Chart"](#) based on the confirmed symptom in step 4, and determine the trouble diagnosis order based on possible causes and symptom.

>> GO TO 10.

TROUBLE DIAGNOSIS

10. DETECT MALFUNCTIONING PART BY DIAGNOSTIC PROCEDURE

Inspect according to Diagnostic Procedure of the system.

NOTE:

The Diagnostic Procedure in EC section described based on open circuit inspection. A short circuit inspection is also required for the circuit check in the Diagnostic Procedure. For details, refer to Circuit Inspection in [GI-26, "How to Perform Efficient Diagnosis for an Electrical Incident"](#) .

Is malfunctioning part detected?

Yes >> GO TO 11.

No >> Monitor input data from related sensors or check voltage of related ECM terminals using CONSULT-II. Refer to [EC-134, "CONSULT-II Reference Value in Data Monitor"](#) , [EC-109, "ECM Terminals and Reference Value"](#) .

11. REPAIR OR REPLACE THE MALFUNCTIONING PART

1. Repair or replace the malfunctioning part.
2. Reconnect parts or connectors disconnected during Diagnostic Procedure again after repair and replacement.
3. Check DTC. If DTC is displayed, erase it, refer to [EC-63, "HOW TO ERASE EMISSION-RELATED DIAGNOSTIC INFORMATION"](#) .

>> GO TO 12.

12. FINAL CHECK

When DTC was detected in step 2, perform DTC Confirmation Procedure or Overall Function Check again, and then make sure that the malfunction have been repaired securely.

When symptom was described from the customer, refer to confirmed symptom in step 3 or 4, and make sure that the symptom is not detected.

OK or NG

NG (DTC*¹ is detected)>>GO TO 10.

NG (Symptom remains)>>GO TO 6.

OK >> 1. Before returning the vehicle to the customer, make sure to erase unnecessary DTC*¹ in ECM and TCM (Transmission Control Module). (Refer to [EC-63, "HOW TO ERASE EMISSION-RELATED DIAGNOSTIC INFORMATION"](#) and [AT-41, "HOW TO ERASE DTC"](#) .)

2. If the completion of SRT is needed, drive vehicle under the specific driving pattern. Refer to [EC-59, "Driving Pattern"](#) .

3. INSPECTION END

*1: Include 1st trip DTC.

*2: Include 1st trip freeze frame data.

DIAGNOSTIC WORKSHEET

Description

There are many operating conditions that lead to the malfunction of engine components. A good grasp of such conditions can make troubleshooting faster and more accurate.

In general, each customer feels differently about an incident. It is important to fully understand the symptoms or conditions for a customer complaint.

Utilize a diagnostic worksheet like the one on the next page in order to organize all the information for troubleshooting.

Some conditions may cause the MIL to come on steady or blink and DTC to be detected. Examples:

- Vehicle ran out of fuel, which caused the engine to misfire.
- Fuel filler cap was left off or incorrectly screwed on, allowing fuel to evaporate into the atmosphere.

KEY POINTS

WHAT Vehicle & engine model
WHEN Date, Frequencies
WHERE..... Road conditions
HOW Operating conditions,
Weather conditions,
Symptoms

SEF907L

TROUBLE DIAGNOSIS

UBS00P1L

DTC Inspection Priority Chart

If some DTCs are displayed at the same time, perform inspections one by one based on the following priority chart.

NOTE:

- If DTC U1000 and/or U1001 is displayed with other DTC, first perform the trouble diagnosis for DTC U1000, U1001. Refer to [EC-159, "DTC U1000, U1001 CAN COMMUNICATION LINE"](#) .
- If DTC U1010 is displayed with other DTC, first perform the trouble diagnosis for DTC U1010. Refer to [EC-162, "DTC U1010 CAN COMMUNICATION"](#) .

Priority	Detected items (DTC)
1	<ul style="list-style-type: none">● U1000 U1001 CAN communication line● U1010 CAN communication● P0101 P0102 P0103 Mass air flow sensor● P0112 P0113 P0127 Intake air temperature sensor● P0117 P0118 P0125 Engine coolant temperature sensor● P0122 P0123 P0222 P0223 P1225 P1226 P2135 Throttle position sensor● P0128 Thermostat function● P0181 P0182 P0183 Fuel tank temperature sensor● P0327 P0328 Knock sensor● P0335 Crankshaft position sensor (POS)● P0340 P0345 Camshaft position sensor (PHASE)● P0403 EGR volume control valve● P0460 P0461 P0462 P0463 Fuel level sensor● P0500 Vehicle speed sensor● P0605 ECM● P0643 Sensor power supply● P0705 P0850 Park/Neutral position (PNP) switch● P1610 - P1615 NATS● P2122 P2123 P2127 P2128 P2138 Accelerator pedal position sensor

TROUBLE DIAGNOSIS

Priority	Detected items (DTC)	
2	<ul style="list-style-type: none"> ● P0031 P0032 P0051 P0052 Air fuel ratio (A/F) sensor 1 heater ● P0037 P0038 P0057 P0058 Heated oxygen sensor 2 heater ● P0075 P0081 Intake valve timing control solenoid valve ● P0130 P0131 P0132 P0133 P0150 P0151 P0152 P0153 P2A00 P2A03 Air fuel ratio (A/F) sensor 1 ● P0137 P0138 P0139 P0157 P0158 P0159 Heated oxygen sensor 2 ● P0405 P0406 EGR temperature sensor ● P0441 EVAP control system purge flow monitoring ● P0443 P0444 P0445 EVAP canister purge volume control solenoid valve ● P0447 P0448 EVAP canister vent control valve ● P0451 P0452 P0453 EVAP control system pressure sensor ● P0550 Power steering pressure sensor ● P0603 ECM power supply ● P1217 Engine over temperature (OVERHEAT) ● P1800 VIAS control solenoid valve ● P1805 Brake switch ● P2100 P2103 Throttle control motor relay ● P2101 Electric throttle control function ● P2118 Throttle control motor 	<p>A</p> <p>EC</p> <p>C</p> <p>D</p> <p>E</p> <p>F</p> <p>G</p>
3	<ul style="list-style-type: none"> ● P0011 P0021 Intake valve timing control ● P0171 P0172 P0174 P0175 Fuel injection system function ● P0300 - P0306 Misfire ● P0400 P1402 EGR system ● P0420 P0430 Three way catalyst function ● P0442 P0456 EVAP control system (SMALL LEAK, VERY SMALL LEAK) ● P0455 EVAP control system (GROSS LEAK) ● P0506 P0507 Idle speed control system ● P0710 P0711 P0717 P0722 P0731 P0732 P0733 P0734 P0735 P0744 P0745 P0750 P0755 P0760 P0762 P0765 P0770 P0775 P0780 P0795 P0797 P0882 A/T related sensors, solenoid valves and switches ● P1148 P1168 Closed loop control ● P1211 TCS control unit ● P1212 TCS communication line ● P1421 Cold start control ● P1564 ASCD steering switch ● P1572 ASCD brake switch ● P1574 ASCD vehicle speed sensor ● P2119 Electric throttle control actuator 	<p>H</p> <p>I</p> <p>J</p> <p>K</p> <p>L</p> <p>M</p>

TROUBLE DIAGNOSIS

Fail-Safe Chart

UBS00P1M

When the DTC listed below is detected, the ECM enters fail-safe mode and the MIL lights up.

DTC No.	Detected items	Engine operating condition in fail-safe mode	
P0102 P0103	Mass air flow sensor circuit	Engine speed will not rise more than 2,400 rpm due to the fuel cut.	
P0117 P0118	Engine coolant temperature sensor circuit	Engine coolant temperature will be determined by ECM based on the time after turning ignition switch ON or START. CONSULT-II displays the engine coolant temperature decided by ECM.	
		Condition	Engine coolant temperature decided (CONSULT-II display)
		Just as ignition switch is turned ON or START	40°C (104°F)
		More than approx. 4 minutes after ignition ON or START	80°C (176°F)
		Except as shown above	40 - 80°C (104 - 176°F) (Depends on the time)
		When the fail-safe system for engine coolant temperature sensor is activated, the cooling fan operates while engine is running.	
P0122 P0123 P0222 P0223 P2135	Throttle position sensor	The ECM controls the electric throttle control actuator in regulating the throttle opening in order for the idle position to be within +10 degrees. The ECM regulates the opening speed of the throttle valve to be slower than the normal condition. So, the acceleration will be poor.	
P0643	Sensor power supply	ECM stops the electric throttle control actuator control, throttle valve is maintained at a fixed opening (approx. 5 degrees) by the return spring.	
P2100 P2103	Throttle control motor relay	ECM stops the electric throttle control actuator control, throttle valve is maintained at a fixed opening (approx. 5 degrees) by the return spring.	
P2101	Electric throttle control function	ECM stops the electric throttle control actuator control, throttle valve is maintained at a fixed opening (approx. 5 degrees) by the return spring.	
P2118	Throttle control motor	ECM stops the electric throttle control actuator control, throttle valve is maintained at a fixed opening (approx. 5 degrees) by the return spring.	
P2119	Electric throttle control actuator	(When electric throttle control actuator does not function properly due to the return spring malfunction:) ECM controls the electric throttle actuator by regulating the throttle opening around the idle position. The engine speed will not rise more than 2,000 rpm.	
		(When ECM detects the throttle valve is stuck open:) While the vehicle is driving, it slows down gradually by fuel cut. After the vehicle stops, the engine stalls. The engine can restart in N or P position, and engine speed will not exceed 1,000 rpm or more.	
		(When throttle valve opening angle in fail-safe mode is not in specified range:) ECM controls the electric throttle control actuator by regulating the throttle opening to 20 degrees or less.	
P2122 P2123 P2127 P2128 P2138	Accelerator pedal position sensor	The ECM controls the electric throttle control actuator in regulating the throttle opening in order for the idle position to be within +10 degrees. The ECM regulates the opening speed of the throttle valve to be slower than the normal condition. So, the acceleration will be poor.	

- When there is an open circuit on MIL circuit, the ECM cannot warn the driver by lighting up MIL when there is malfunction on engine control system.
Therefore, when electrical controlled throttle and part of ECM related diagnoses are continuously detected as NG for 5 trips, ECM warns the driver that engine control system malfunctions and MIL circuit is open by means of operating fail-safe function.
The fail-safe function also operates when above diagnoses except MIL circuit are detected, and demands the driver to repair the malfunction.

Engine operating condition in fail-safe mode	Engine speed will not rise more than 2,500 rpm due to the fuel cut
--	--

TROUBLE DIAGNOSIS

Symptom Matrix Chart SYSTEM — BASIC ENGINE CONTROL SYSTEM

UBS00P1N

A

EC

C

D

E

F

G

H

I

J

K

L

M

		SYMPTOM												Reference page	
		HARD/NO START/RESTART (EXCP. HA)	ENGINE STALL	HESITATION/SURGING/FLAT SPOT	SPARK KNOCK/DETONATION	LACK OF POWER/POOR ACCELERATION	HIGH IDLE/LOW IDLE	ROUGH IDLE/HUNTING	IDLING VIBRATION	SLOW/NO RETURN TO IDLE	OVERHEATS/WATER TEMPERATURE HIGH	EXCESSIVE FUEL CONSUMPTION	EXCESSIVE OIL CONSUMPTION		BATTERY DEAD (UNDER CHARGE)
Warranty symptom code		AA	AB	AC	AD	AE	AF	AG	AH	AJ	AK	AL	AM	HA	
Fuel	Fuel pump circuit	1	1	2	3	2		2	2			3		2	EC-685
	Fuel pressure regulator system	3	3	4	4	4	4	4	4	4		4			EC-83
	Fuel injector circuit	1	1	2	3	2		2	2			2			EC-678
	Evaporative emission system	3	3	4	4	4	4	4	4	4	4	4			EC-32
Air	Positive crankcase ventilation system	3	3	4	4	4	4	4	4	4		4	1		EC-45
	Incorrect idle speed adjustment						1	1	1	1		1			EC-73
	Electric throttle control actuator	1	1	2	3	3	2	2	2	2		2		2	EC-602 , EC-615
Ignition	Incorrect ignition timing adjustment	3	3	1	1	1		1	1			1			EC-73
	Ignition circuit	1	1	2	2	2		2	2			2			EC-691
EGR	EGR volume control valve circuit		2												EC-405
	EGR system	2	1	2	3	3	3	2	2	3		3			EC-397 , EC-559
Main power supply and ground circuit		2	2	3	3	3		3	3		2	3			EC-150
Mass air flow sensor circuit		1			2										EC-192 , EC-202
Engine coolant temperature sensor circuit								3			3				EC-216 , EC-230
A/F sensor 1 circuit				1	2	3	2		2	2			2		EC-168 , EC-239 , EC-250 , EC-260 , EC-270 , EC-648
Throttle position sensor circuit											2				EC-222 , EC-357 , EC-555 , EC-557 , EC-632
Accelerator pedal position sensor circuit				3	2	1									EC-529 , EC-617 , EC-624 , EC-640
Knock sensor circuit				2								3			EC-374

TROUBLE DIAGNOSIS

	SYMPTOM													Reference page
	HARD/NO START/RESTART (EXCP. HA)	ENGINE STALL	HESITATION/SURGING/FLAT SPOT	SPARK KNOCK/DETONATION	LACK OF POWER/POOR ACCELERATION	HIGH IDLE/LOW IDLE	ROUGH IDLE/HUNTING	IDLING VIBRATION	SLOW/NO RETURN TO IDLE	OVERHEATS/WATER TEMPERATURE HIGH	EXCESSIVE FUEL CONSUMPTION	EXCESSIVE OIL CONSUMPTION	BATTERY DEAD (UNDER CHARGE)	
Warranty symptom code	AA	AB	AC	AD	AE	AF	AG	AH	AJ	AK	AL	AM	HA	
Crankshaft position sensor (POS) circuit	2	2												EC-379
Camshaft position sensor (PHASE) circuit	3	2												EC-387
Vehicle speed signal circuit		2	3		3						3			EC-510
Power steering pressure sensor circuit		2					3	3						EC-516
ECM	2	2	3	3	3	3	3	3	3	3	3			EC-522 , EC-526
Intake valve timing control solenoid valve circuit		3	2		1	3	2	2	3		3			EC-185
PNP switch circuit			3		3		3	3			3			EC-535
VIAS control solenoid valve circuit					1									EC-586
Refrigerant pressure sensor circuit		2				3			3		4			EC-704
Electrical load signal circuit							3							EC-671
Air conditioner circuit	2	2	3	3	3	3	3	3	3		3		2	ATC-32 or MTC-32
ABS actuator and electric unit (control unit)			4											BRC-10 or BRC-55

1 - 6: The numbers refer to the order of inspection.
(continued on next page)

TROUBLE DIAGNOSIS

SYSTEM — ENGINE MECHANICAL & OTHER

		SYMPTOM											Reference page		
		HARD/NO START/RESTART (EXC.P. HA)	ENGINE STALL	HESITATION/SURGING/FLAT SPOT	SPARK KNOCK/DETONATION	LACK OF POWER/POOR ACCELERATION	HIGH IDLE/LOW IDLE	ROUGH IDLE/HUNTING	IDLING VIBRATION	SLOW/NO RETURN TO IDLE	OVERHEATS/WATER TEMPERATURE HIGH	EXCESSIVE FUEL CONSUMPTION		EXCESSIVE OIL CONSUMPTION	BATTERY DEAD (UNDER CHARGE)
Warranty symptom code		AA	AB	AC	AD	AE	AF	AG	AH	AJ	AK	AL	AM	HA	
Fuel	Fuel tank	5	5											FL-9	
	Fuel piping			5	5	5		5	5			5		EM-40	
	Vapor lock														—
	Valve deposit														—
	Poor fuel (Heavy weight gasoline, Low octane)	5			5	5	5		5	5			5		
Air	Air duct													EM-16	
	Air cleaner													EM-16	
	Air leakage from air duct (Mass air flow sensor — electric throttle control actuator)	5	5	5		5		5	5			5		EM-16	
	Electric throttle control actuator			5		5				5				EM-18	
	Air leakage from intake manifold/Collector/Gasket													EM-18 , EM-24	
Cranking	Battery	1	1	1		1		1	1					1	SC-4
	Generator circuit														SC-18
	Starter circuit	3										1		SC-10	
	Signal plate	6												EM-118	
	PNP switch	4												AT-91	
Engine	Cylinder head	5	5	5	5	5		5	5			5	3		EM-96
	Cylinder head gasket														4
	Cylinder block														
	Piston												4		
	Piston ring	6	6	6	6	6		6	6			6			EM-118
	Connecting rod														
	Bearing														
	Crankshaft														
Valve mechanism	Timing chain														EM-56
	Camshaft														EM-56
	Intake valve timing control	5	5	5	5	5		5	5			5			EM-56
	Intake valve														
	Exhaust valve												3		EM-96

TROUBLE DIAGNOSIS

		SYMPTOM												Reference page	
		HARD/NO START/RESTART (EXCP. HA)	ENGINE STALL	HESITATION/SURGING/FLAT SPOT	SPARK KNOCK/DETONATION	LACK OF POWER/POOR ACCELERATION	HIGH IDLE/LOW IDLE	ROUGH IDLE/HUNTING	IDLING VIBRATION	SLOW/NO RETURN TO IDLE	OVERHEATS/WATER TEMPERATURE HIGH	EXCESSIVE FUEL CONSUMPTION	EXCESSIVE OIL CONSUMPTION		BATTERY DEAD (UNDER CHARGE)
Warranty symptom code		AA	AB	AC	AD	AE	AF	AG	AH	AJ	AK	AL	AM	HA	
Exhaust	Exhaust manifold/Tube/Muffler/Gasket	5	5	5	5	5		5	5			5			EM-26 , EX-3
	Three way catalyst														
Lubrica- tion	Oil pan/Oil strainer/Oil pump/Oil filter/Oil gallery/Oil cooler	5	5	5	5	5		5	5			5			EM-30 , LU-11 , LU-12 , LU-16
	Oil level (Low)/Filthy oil														LU-8
Cooling	Radiator/Hose/Radiator filler cap														CO-15
	Thermostat									5					CO-23
	Water pump														CO-18
	Water gallery	5	5	5	5	5		5	5		4	5			CO-25
	Cooling fan														EC-544
	Coolant level (Low)/Contami-nated coolant										5				CO-9
NVIS (NISSAN Vehicle Immobilizer System — NATS)		1	1												BL-203

1 - 6: The numbers refer to the order of inspection.

TROUBLE DIAGNOSIS

Engine Control Component Parts Location

UBS00P10

A

EC

C

D

E

F

G

H

I

J

K

L

M

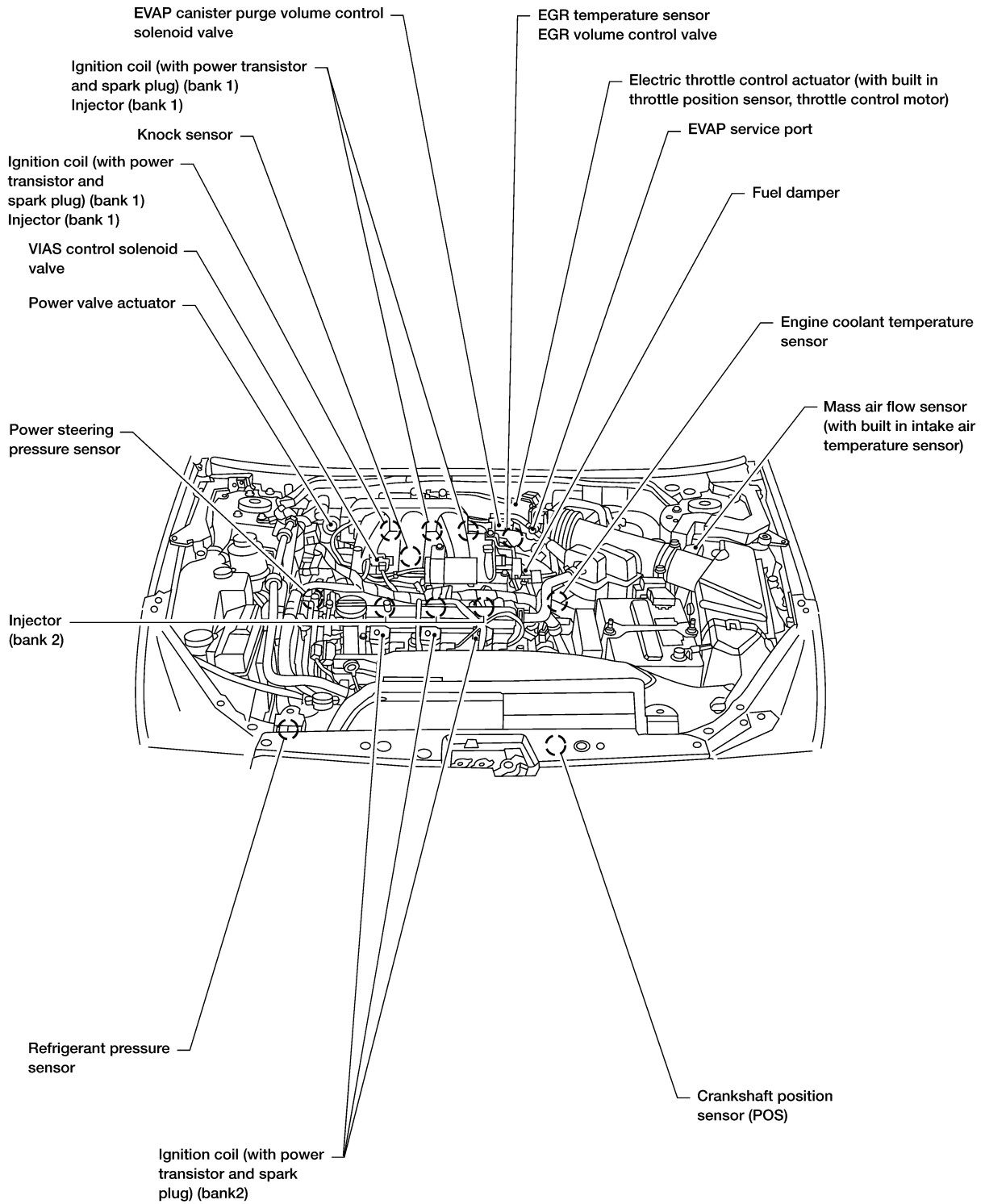

BBIA0314E

TROUBLE DIAGNOSIS

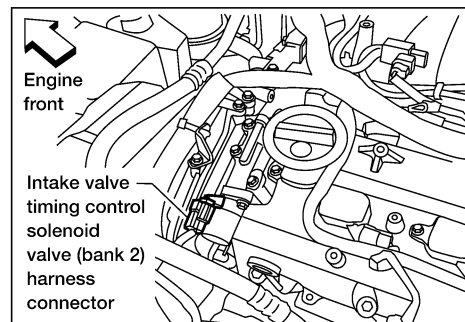
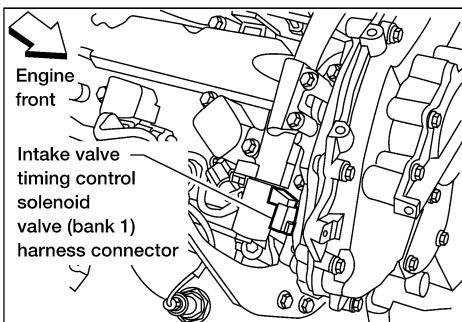
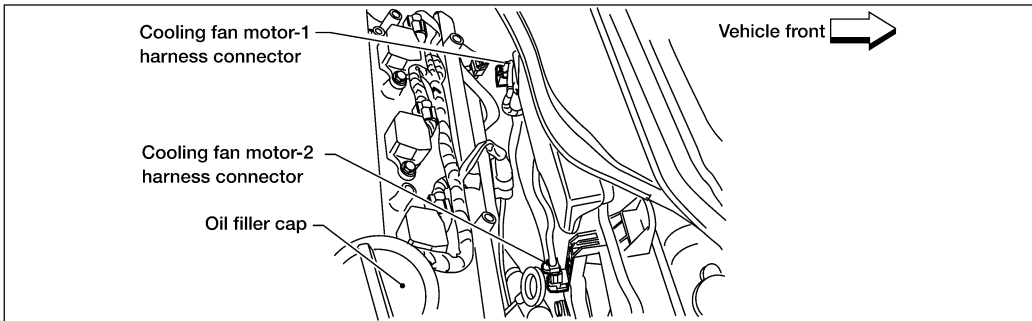
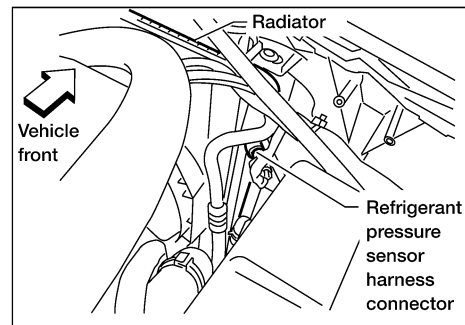
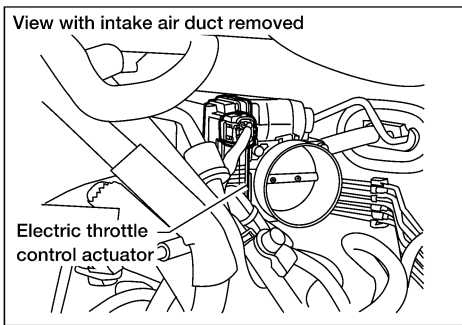
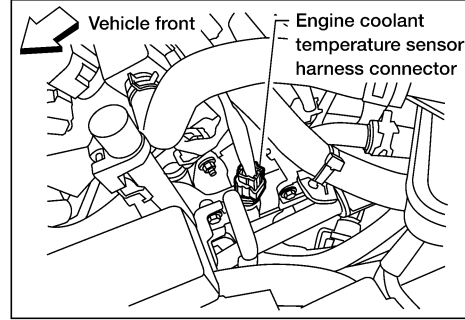
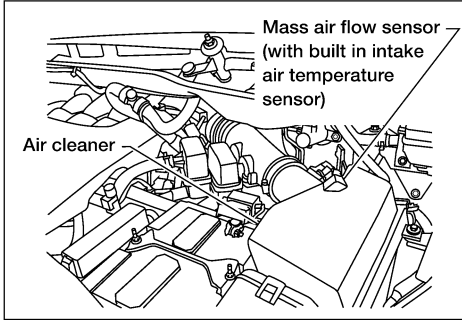

BBIA0321E

TROUBLE DIAGNOSIS

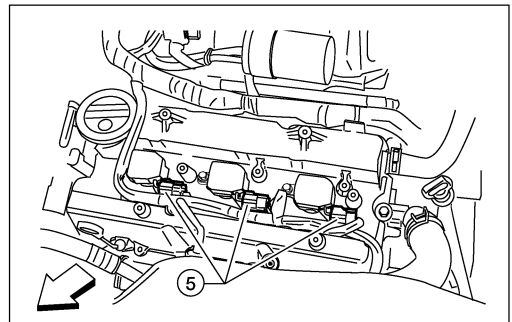
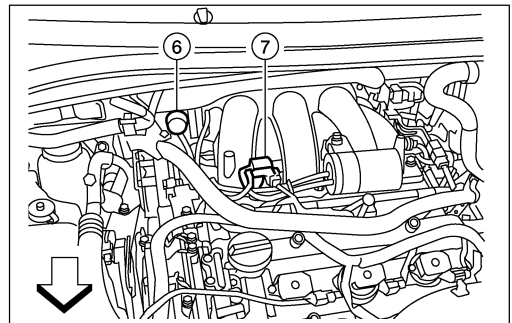
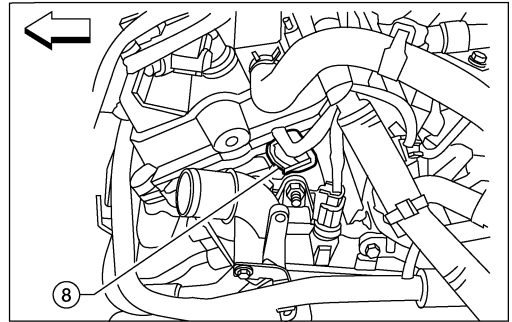
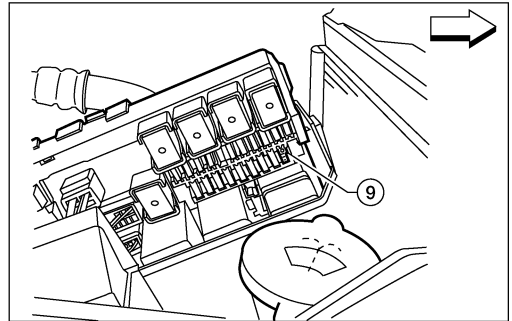
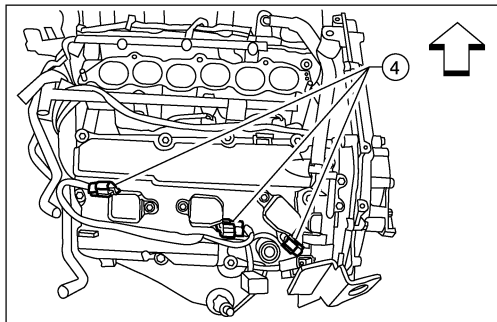
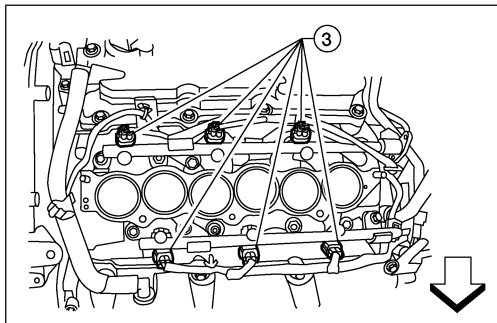
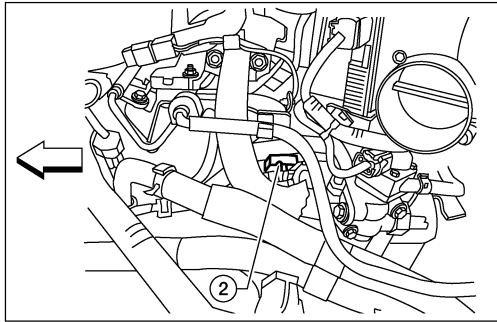
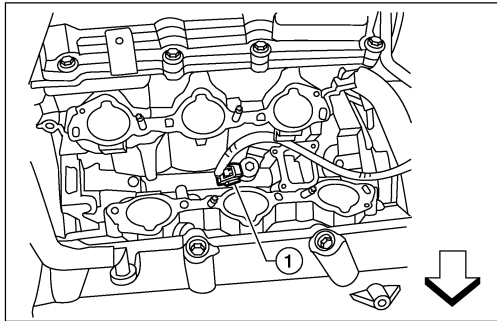

A
EC
C
D
E
F
G
H
I
J
K
L
M

← Vehicle front

- | | | |
|---|--|------------------------------------|
| 1. Knock sensor harness connector | 2. Camshaft position sensor (PHASE) (bank 1) harness connector | 3. Fuel injector harness connector |
| 4. Ignition coil harness connector (bank 1) | 5. Ignition coil harness connector (bank 2) | 6. Power valve actuator |
| 7. VIAS control solenoid valve | 8. Camshaft position sensor (PHASE) (bank 2) harness connector | 9. Fuel pump fuse (15A) |

BBIA0652E

TROUBLE DIAGNOSIS

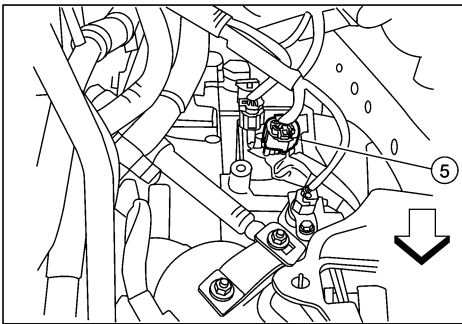
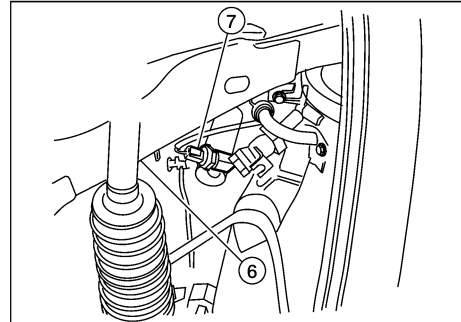
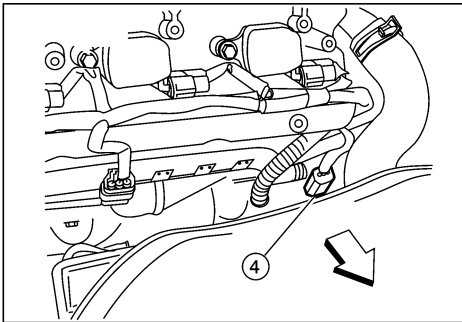
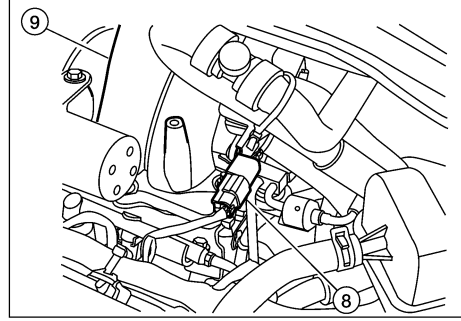
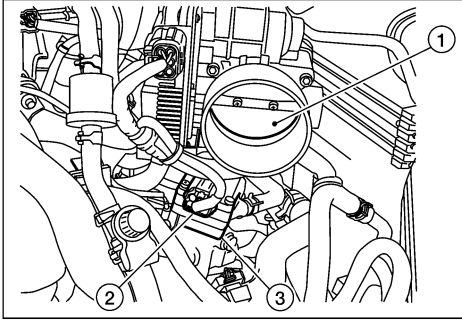

BBIA0682E

← Vehicle front

- | | | |
|---|---|--|
| 1. Throttle valve
(view with intake air duct removed) | 2. EGR volume control valve harness connector | 3. EGR volume control valve |
| 4. Electronic controlled engine mount-1 harness connector | 5. Park/neutral position switch harness connector
(view with battery tray removed) | 6. Tie rod RH
(view from under vehicle) |
| 7. Power steering pressure sensor harness connector | 8. EGR temperature sensor harness connector
(view with engine cover removed) | 9. Intake manifold collector |

TROUBLE DIAGNOSIS

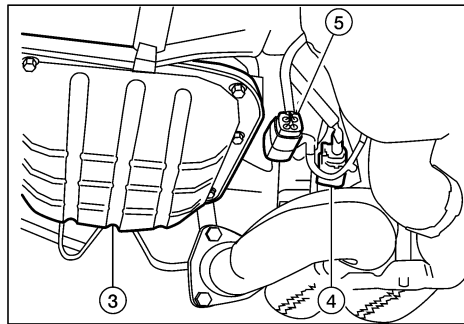
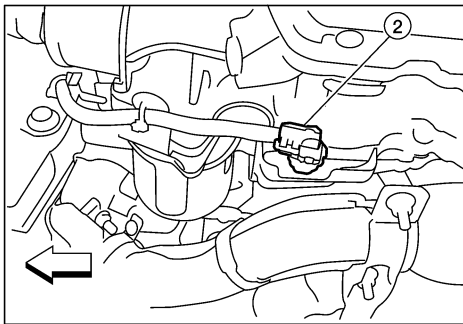
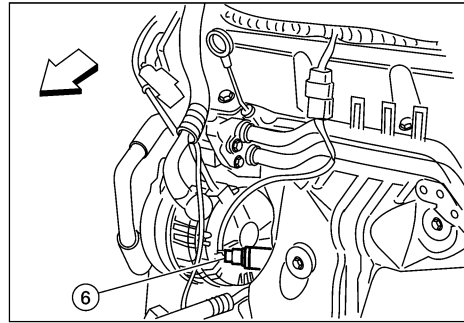
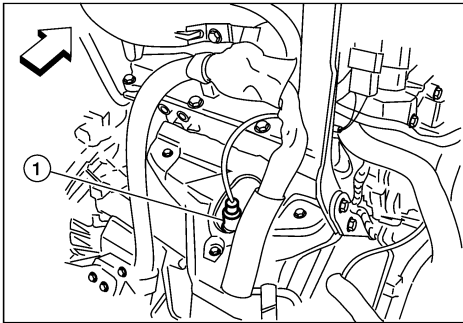
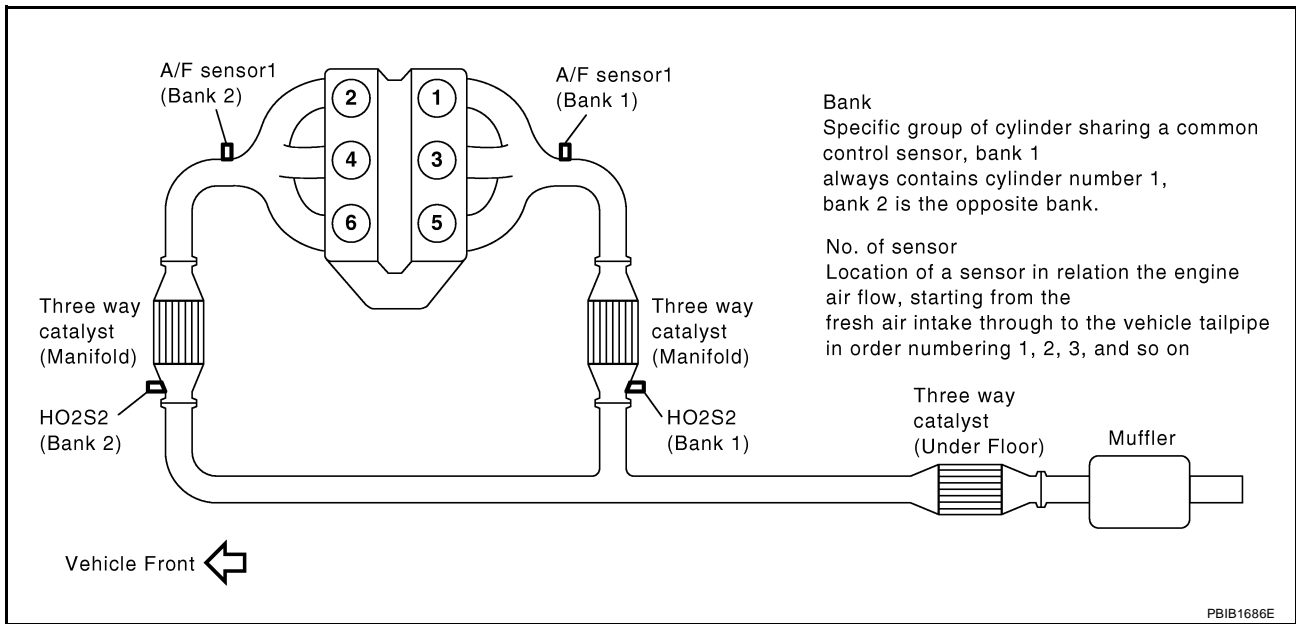

← Vehicle front

- | | | |
|--|---|--|
| 1. Air fuel ratio sensor 1 (bank 1) | 2. Crankshaft position sensor (POS) (view from under the vehicle) | 3. Oil pan (view from under the vehicle) |
| 4. Heated oxygen sensor 2 (bank 2) harness connector | 5. Heated oxygen sensor 2 (bank 1) harness connector | 6. Air fuel ratio sensor 1 (bank 2) |

BBIA0683E

TROUBLE DIAGNOSIS

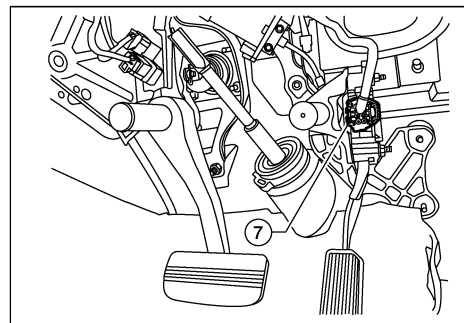
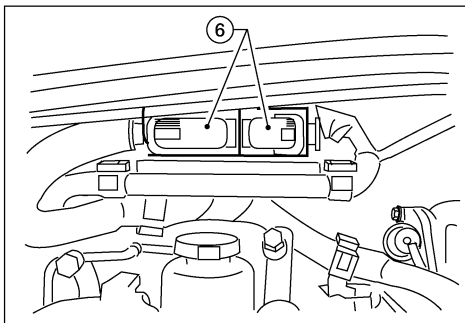
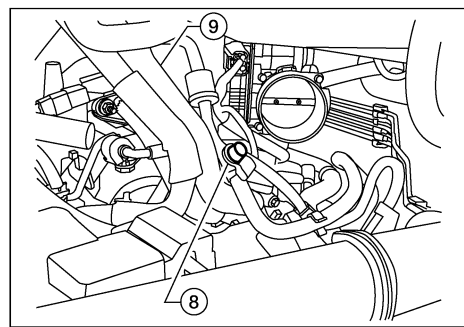
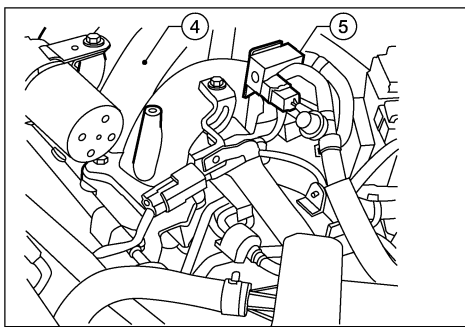
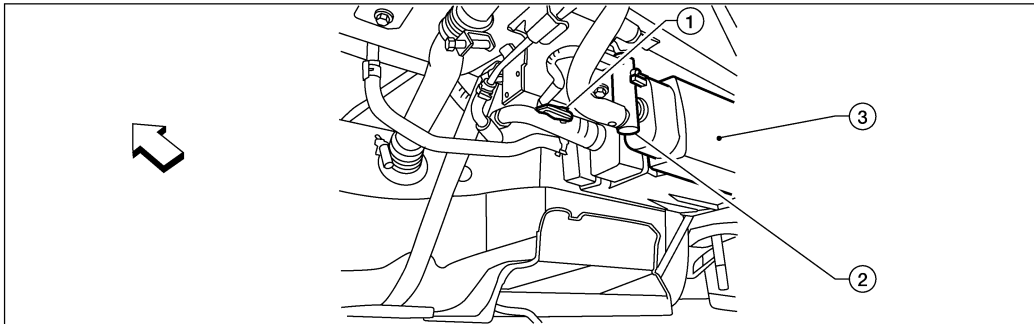

←: Vehicle front

- | | | |
|--|--|------------------------------|
| 1. EVAP control system pressure sensor | 2. EVAP canister vent control valve | 3. EVAP canister |
| 4. Intake manifold collector | 5. EVAP canister purge volume control solenoid valve | 6. ECM harness connector |
| 7. Accelerator pedal position (APP) sensor harness connector | 8. EVAP service port | 9. Intake manifold collector |

BBIA0665E

TROUBLE DIAGNOSIS

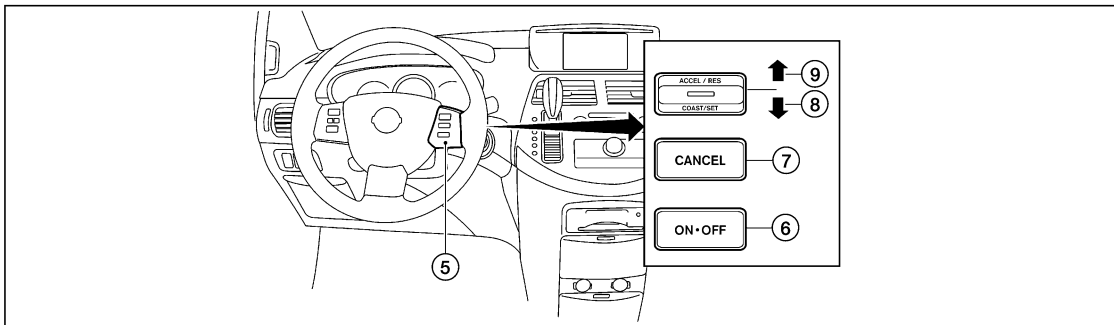
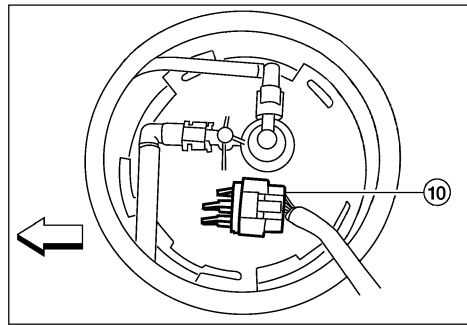
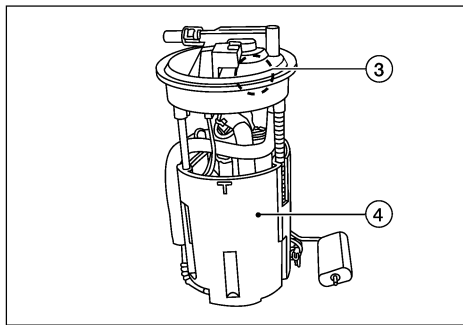
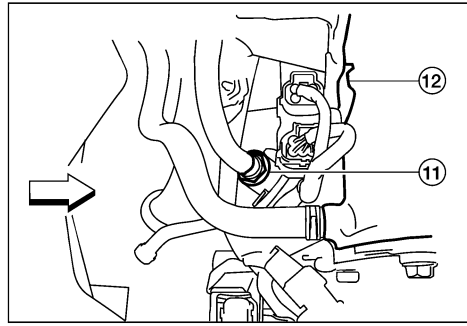
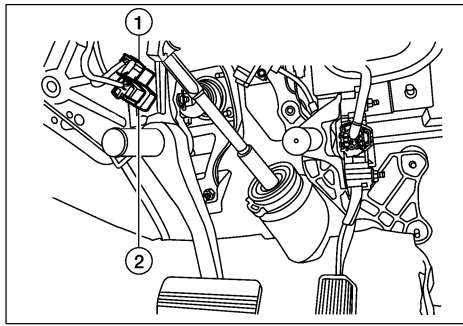

BBIA0684E

← Vehicle front

- | | | |
|--|--|-------------------------------|
| 1. ASCD brake switch | 2. Stop lamp switch | 3. Fuel pressure regulator |
| 4. Fuel pump, fuel level sensor unit and fuel filler | 5. ASCD steering switch | 6. MAIN switch |
| 7. CANCEL switch | 8. SET/COAST switch | 9. RESUME/ACCELERATE switch |
| 10. Fuel level sensor unit and fuel pump harness connector (view with fuel tank removed) | 11. PCV valve (view with cowl removed) | 12. Intake manifold collector |

TROUBLE DIAGNOSIS

Vacuum Hose Drawing

UBS00P1P

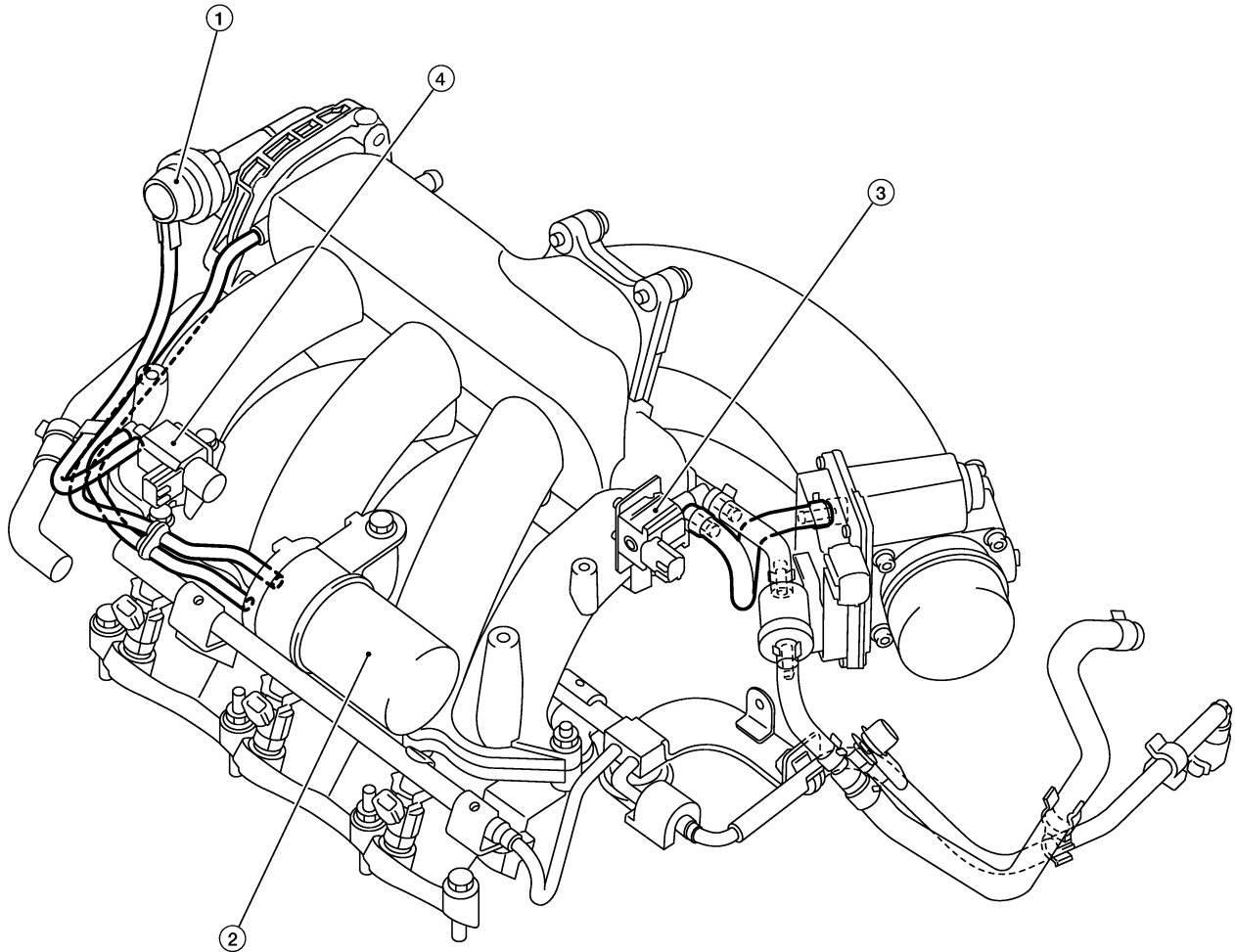

1. Power valve actuator

2. Vacuum tank

3. EVAP canister purge volume control solenoid valve

4. VIAS control solenoid valve

NOTE:

Do not use soapy water or any type of solvent while installing vacuum hose or purge hoses.

Refer to [EC-23. "System Diagram"](#) for Vacuum Control System.

BBIA0663E

TROUBLE DIAGNOSIS

Circuit Diagram

UBS00P1Q

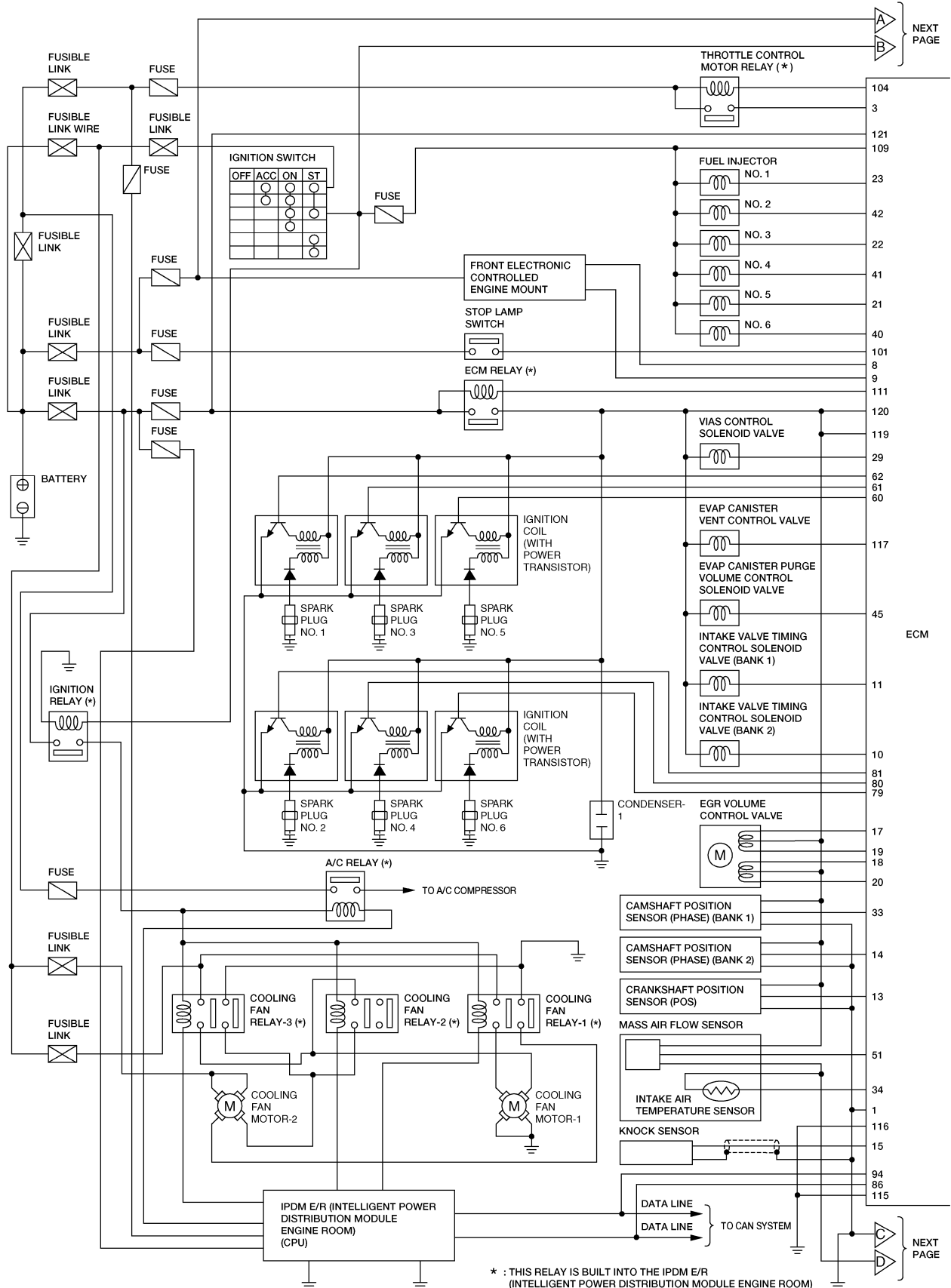

BBWA2498E

TROUBLE DIAGNOSIS

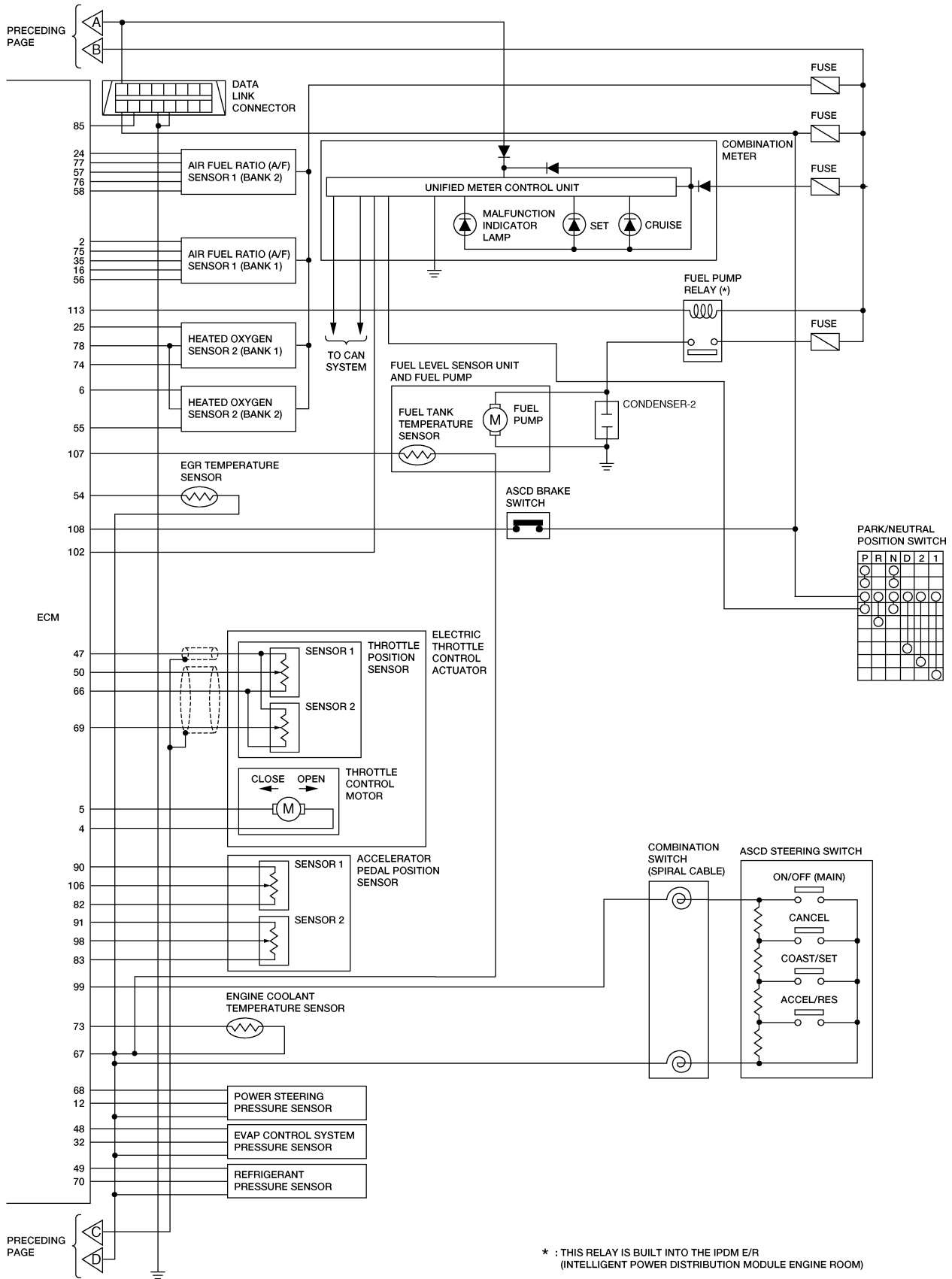

* : THIS RELAY IS BUILT INTO THE IPDM E/R (INTELLIGENT POWER DISTRIBUTION MODULE ENGINE ROOM)

BBWA2499E

TROUBLE DIAGNOSIS

ECM Harness Connector Terminal Layout

UBS00P1R

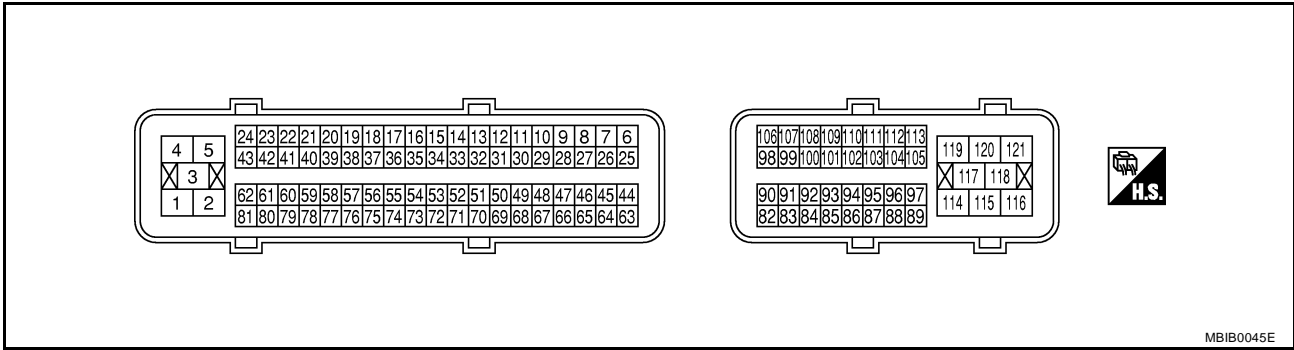

MBIB0045E

ECM Terminals and Reference Value PREPARATION

UBS00P1S

1. ECM is located in the right side of the cowl top (behind the strut tower).
2. Remove ECM harness connector.

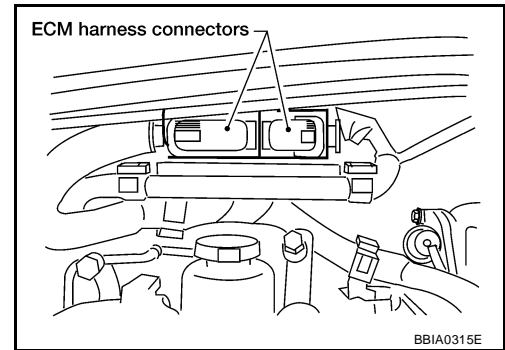

BBIA0315E

3. When disconnecting ECM harness connector, loosen it with levers as far as they will go as shown in the figure.
4. Connect a break-out box (SST) and Y-cable adapter (SST) between the ECM and ECM harness connector.
 - Use extreme care not to touch 2 pins at one time.
 - Data is for comparison and may not be exact.

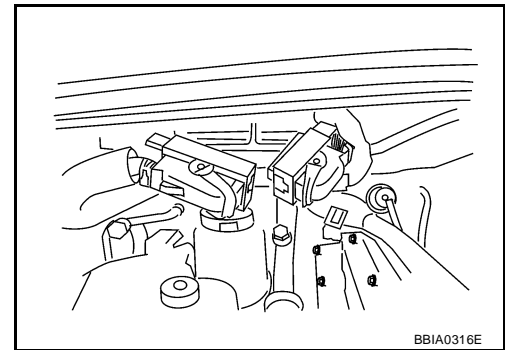

BBIA0316E

ECM INSPECTION TABLE

Specification data are reference values and are measured between each terminal and ground. Pulse signal is measured by CONSULT-II.

CAUTION:

Do not use ECM ground terminals when measuring input/output voltage. Doing so may result in damage to the ECMs transistor. Use a ground other than ECM terminals, such as the ground.

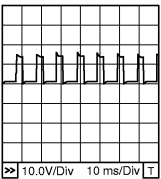
TER-MINAL NO.	WIRE COLOR	ITEM	CONDITION	DATA (DC Voltage)
1	B	ECM ground	[Engine is running] ● Idle speed	Body ground
2	R/G	A/F sensor 1 heater (Bank 1)	[Engine is running] ● Warm-up condition ● Idle speed	Approximately 5V★ 

PBIB1584E

TROUBLE DIAGNOSIS

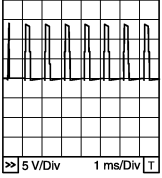
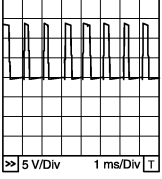
TER-MINAL NO.	WIRE COLOR	ITEM	CONDITION	DATA (DC Voltage)
3	R	Throttle control motor relay power supply	[Ignition switch: ON]	BATTERY VOLTAGE (11 - 14V)
4	O/L	Throttle control motor (Close)	[Ignition switch: ON] <ul style="list-style-type: none"> ● Engine stopped ● Shift lever: D ● Accelerator pedal: Fully released 	0 - 14V★  <small>PBIB1104E</small>
5	W/L	Throttle control motor (Open)	[Ignition switch: ON] <ul style="list-style-type: none"> ● Engine stopped ● Shift lever: D ● Accelerator pedal: Fully depressed 	0 - 14V★  <small>PBIB1105E</small>
6	GR	Heated oxygen sensor 2 heater (Bank 2)	[Engine is running] <ul style="list-style-type: none"> ● Engine speed: Below 3,600 rpm after the following conditions are met <ul style="list-style-type: none"> - Engine: After warming up - Keeping the engine speed between 3,500 and 4,000 rpm for 1 minute and at idle for 1 minute under no load. 	0 - 1.0V
			[Ignition switch: ON] <ul style="list-style-type: none"> ● Engine stopped [Engine is running] <ul style="list-style-type: none"> ● Engine speed: Above 3,600 rpm 	BATTERY VOLTAGE (11 - 14V)
8	W	Electronic controlled engine mount-1	[Engine is running] <ul style="list-style-type: none"> ● Engine speed: Above 950 rpm 	BATTERY VOLTAGE (11 - 14V)
			[Engine is running] <ul style="list-style-type: none"> ● For 2 seconds after engine speed: 950 rpm or less 	0 - 1.0V
			[Engine is running] <ul style="list-style-type: none"> ● 2 seconds after engine speed: 950 rpm or less 	2.0 - 3.0V
9	W/R	Electronic controlled engine mount-2	[Engine is running] <ul style="list-style-type: none"> ● Engine speed: Below 950 rpm 	BATTERY VOLTAGE (11 - 14V)
			[Engine is running] <ul style="list-style-type: none"> ● For 2 seconds after engine speed: 950 rpm or more 	0 - 1.0V
			[Engine is running] <ul style="list-style-type: none"> ● 2 seconds after engine speed: 950 rpm or more 	2.0 - 3.0V

TROUBLE DIAGNOSIS

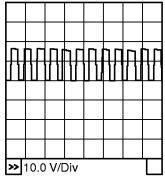
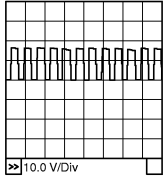
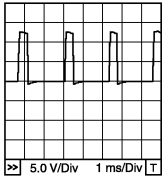
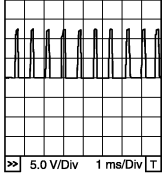
TER-MINAL NO.	WIRE COLOR	ITEM	CONDITION	DATA (DC Voltage)
10	Y/L	Intake valve timing control solenoid valve (Bank 2)	[Engine is running] <ul style="list-style-type: none"> ● Warm-up condition ● Idle speed 	BATTERY VOLTAGE (11 - 14V)
			[Engine is running] <ul style="list-style-type: none"> ● Warm-up condition ● Engine speed: 2,000 rpm 	7 - 12V★  <small>PBIB1790E</small>
11	R/L	Intake valve timing control solenoid valve (Bank 1)	[Engine is running] <ul style="list-style-type: none"> ● Warm-up condition ● Idle speed 	BATTERY VOLTAGE (11 - 14V)
			[Engine is running] <ul style="list-style-type: none"> ● Warm-up condition ● Engine speed: 2,000 rpm 	7 - 12V★  <small>PBIB1790E</small>
12	W	Power steering pressure sensor	[Engine is running] <ul style="list-style-type: none"> ● Steering wheel: Being turned 	0.5 - 4.5V
			[Engine is running] <ul style="list-style-type: none"> ● Steering wheel: Not being turned 	0.4 - 0.8V
13	W	Crankshaft position sensor (POS)	[Engine is running] <ul style="list-style-type: none"> ● Warm-up condition ● Idle speed NOTE: The pulse cycle changes depending on rpm at idle	Approximately 10V★  <small>PBIB1041E</small>
			[Engine is running] <ul style="list-style-type: none"> ● Engine speed: 2,000 rpm 	Approximately 10V★  <small>PBIB1042E</small>

A
EC
C
D
E
F
G
H
I
J
K
L
M

TROUBLE DIAGNOSIS

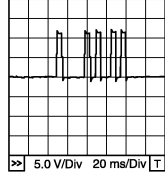
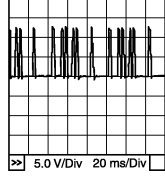
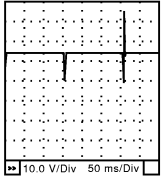
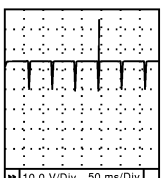
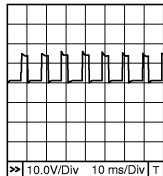
TER-MINAL NO.	WIRE COLOR	ITEM	CONDITION	DATA (DC Voltage)
14	W	Camshaft position sensor (PHASE) (Bank 2)	[Engine is running] <ul style="list-style-type: none"> ● Warm-up condition ● Idle speed NOTE: The pulse cycle changes depending on rpm at idle	1.0 - 4.0V★  <small>PBIB1039E</small>
			[Engine is running] <ul style="list-style-type: none"> ● Engine speed: 2,000 rpm 	1.0 - 4.0V★  <small>PBIB1040E</small>
15	W	Knock sensor	[Engine is running] <ul style="list-style-type: none"> ● Idle speed 	Approximately 2.5V
16	BR	A/F sensor 1 (Bank 1)	[Engine is running] <ul style="list-style-type: none"> ● Warm-up condition ● Idle speed 	Approximately 3.1V
35	O/B			Approximately 2.6V
56	V			Approximately 2.3V
75	P			Approximately 2.3V
17 18 19 20	P/B G L L/W	EGR volume control valve	[Engine is running] <ul style="list-style-type: none"> ● Idle speed 	0.1 - 14V
21 22 23	L/W R/Y R/B	Fuel injector No. 5 Fuel injector No. 3 Fuel injector No. 1	[Engine is running] <ul style="list-style-type: none"> ● Warm-up condition ● Idle speed NOTE: The pulse cycle changes depending on rpm at idle	BATTERY VOLTAGE (11 - 14V)★  <small>SEC984C</small>
			[Engine is running] <ul style="list-style-type: none"> ● Warm-up condition ● Engine speed: 2,000 rpm 	BATTERY VOLTAGE (11 - 14V)★  <small>SEC985C</small>
24	W	A/F sensor 1 heater (Bank 2)	[Engine is running] <ul style="list-style-type: none"> ● Warm-up condition ● Idle speed 	Approximately 5V★  <small>PBIB1584E</small>

TROUBLE DIAGNOSIS

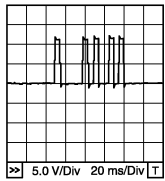
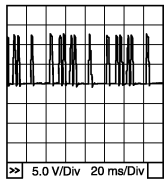
TER-MINAL NO.	WIRE COLOR	ITEM	CONDITION	DATA (DC Voltage)	
25	P	Heated oxygen sensor 2 heater (Bank 1)	[Engine is running] <ul style="list-style-type: none"> ● Engine speed: Below 3,600 rpm after the following conditions are met <ul style="list-style-type: none"> - Engine: After warming up - Keeping the engine speed between 3,500 and 4,000 rpm for 1 minute and at idle for 1 minute under no load. 	0 - 1.0V	A
			[Ignition switch: ON] <ul style="list-style-type: none"> ● Engine stopped [Engine is running] <ul style="list-style-type: none"> ● Engine speed: Above 3,600 rpm 	BATTERY VOLTAGE (11 - 14V)	EC
29	Y/G	VIAS control solenoid valve	[Engine is running] <ul style="list-style-type: none"> ● Idle speed 	BATTERY VOLTAGE (11 - 14V)	C
			[Engine is running] <ul style="list-style-type: none"> ● Engine speed: Between 1,800 and 3,600 rpm 	0 - 1.0V	D
32	BR	EVAP control system pressure sensor	[Ignition switch: ON]	Approximately 1.8 - 4.8V	E
33	Y	Camshaft position sensor (PHASE) (Bank 1)	[Engine is running] <ul style="list-style-type: none"> ● Warm-up condition ● Idle speed NOTE: The pulse cycle changes depending on rpm at idle	1.0 - 4.0V★ 	F
			[Engine is running] <ul style="list-style-type: none"> ● Engine speed: 2,000 rpm 	1.0 - 4.0V★ 	G
34	Y/G	Intake air temperature sensor	[Engine is running]	Approximately 0 - 4.8V Output voltage varies with intake air temperature.	H

TROUBLE DIAGNOSIS

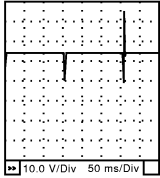
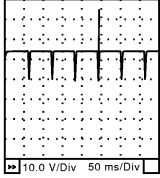
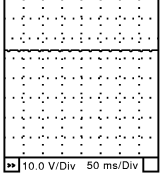
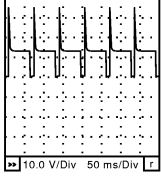
TER-MINAL NO.	WIRE COLOR	ITEM	CONDITION	DATA (DC Voltage)
40 41 42	V/W R/L R/W	Fuel injector No. 6 Fuel injector No. 4 Fuel injector No. 2	<p>[Engine is running]</p> <ul style="list-style-type: none"> ● Warm-up condition ● Idle speed <p>NOTE: The pulse cycle changes depending on rpm at idle</p>	<p>BATTERY VOLTAGE (11 - 14V)★</p>  <p style="text-align: right;">SEC984C</p>
			<p>[Engine is running]</p> <ul style="list-style-type: none"> ● Warm-up condition ● Engine speed: 2,000 rpm 	<p>BATTERY VOLTAGE (11 - 14V)★</p>  <p style="text-align: right;">SEC985C</p>
45	V/R	EVAP canister purge volume control solenoid valve	<p>[Engine is running]</p> <ul style="list-style-type: none"> ● Idle speed ● Accelerator pedal: Not depressed even slightly, after engine starting. 	<p>BATTERY VOLTAGE (11 - 14V)★</p>  <p style="text-align: right;">SEC990C</p>
			<p>[Engine is running]</p> <ul style="list-style-type: none"> ● Engine speed: About 2,000 rpm (More than 100 seconds after starting engine) 	<p>BATTERY VOLTAGE (11 - 14V)★</p>  <p style="text-align: right;">SEC991C</p>
47	R	Throttle position sensor power supply	[Ignition switch: ON]	Approximately 5V
48	G/O	EVAP control system pressure sensor power supply	[Ignition switch: ON]	Approximately 5V
49	BR/Y	Refrigerant pressure sensor power supply	[Ignition switch: ON]	Approximately 5V
50	Y	Throttle position sensor 1	<p>[Ignition switch: ON]</p> <ul style="list-style-type: none"> ● Engine stopped ● Shift lever: D ● Accelerator pedal: Fully released 	More than 0.36V
			<p>[Ignition switch: ON]</p> <ul style="list-style-type: none"> ● Engine stopped ● Shift lever: D ● Accelerator pedal: Fully depressed 	Less than 4.75V

TROUBLE DIAGNOSIS

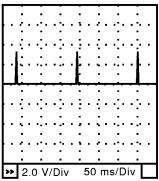
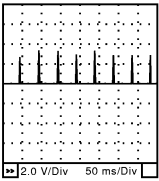
TER-MINAL NO.	WIRE COLOR	ITEM	CONDITION	DATA (DC Voltage)	
51	W/L	Mass air flow sensor	[Engine is running] ● Warm-up condition ● Idle speed	1.0 - 1.3V	A EC
			[Engine is running] ● Warm-up condition ● Engine speed: 2,500 rpm	1.6 - 2.0V	C
54	P/L	EGR temperature sensor	[Ignition switch: ON]	Less than 4.5V	D
			[Engine is running] ● Warm-up condition ● EGR system: Operating	0 - 1.5V	E
55	W	Heated oxygen sensor 2 (Bank 2)	[Engine is running] ● Revving engine from idle to 3,000 rpm quickly after the following conditions are met – Engine: After warming up – Keeping the engine speed between 3,500 and 4,000 rpm for 1 minute and at idle for 1 minute under no load	0 - Approximately 1.0V	F
57	W/R	A/F sensor 1 (Bank 2)	[Engine is running] ● Warm-up condition ● Idle speed	Approximately 2.6V	G H I
58	LG/R			Approximately 2.3V	
76	O			Approximately 3.1V	
77	LG			Approximately 2.3V	
60 61 62	P/L L/R Y/R	Ignition signal No. 5 Ignition signal No. 3 Ignition signal No. 1	[Engine is running] ● Warm-up condition ● Idle speed NOTE: The pulse cycle changes depending on rpm at idle	0 - 0.4V★  SEC986C	J
			[Engine is running] ● Warm-up condition ● Engine speed: 2,500 rpm	0.1 - 0.6V★  SEC987C	K L M
66	G	Throttle position sensor ground	[Engine is running] ● Warm-up condition ● Idle speed	Approximately 0V	
67	B	Sensor ground	[Engine is running] ● Warm-up condition ● Idle speed	Approximately 0V	
68	BR/W	PSP sensor power supply	[Ignition switch: ON]	Approximately 5V	

TROUBLE DIAGNOSIS

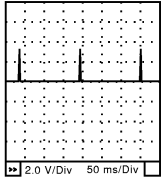
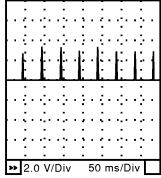
TER-MINAL NO.	WIRE COLOR	ITEM	CONDITION	DATA (DC Voltage)
69	L	Throttle position sensor 2	[Ignition switch: ON] <ul style="list-style-type: none"> ● Engine stopped ● Shift lever: D ● Accelerator pedal: Fully released 	Less than 4.75V
			[Ignition switch: ON] <ul style="list-style-type: none"> ● Engine stopped ● Shift lever: D ● Accelerator pedal: Fully depressed 	More than 0.36V
70	W	Refrigerant pressure sensor	[Engine is running] <ul style="list-style-type: none"> ● Warm-up condition ● Both A/C switch and blower fan switch: ON (Compressor operates.) 	1.0 - 4.0V
73	Y/B	Engine coolant temperature sensor	[Engine is running]	Approximately 0 - 4.8V Output voltage varies with engine coolant temperature.
74	W	Heated oxygen sensor 2 (Bank 1)	[Engine is running] <ul style="list-style-type: none"> ● Revving engine from idle to 3,000 rpm quickly after the following conditions are met <ul style="list-style-type: none"> - Engine: After warming up - Keeping the engine speed between 3,500 and 4,000 rpm for 1 minute and at idle for 1 minute under no load 	0 - Approximately 1.0V
78	B	Heated oxygen sensor 2 ground	[Engine is running] <ul style="list-style-type: none"> ● Warm-up condition ● Idle speed 	Approximately 0V
79 80 81	GR/R GR G/R	Ignition signal No. 6 Ignition signal No. 4 Ignition signal No. 2	[Engine is running] <ul style="list-style-type: none"> ● Warm-up condition ● Idle speed NOTE: The pulse cycle changes depending on rpm at idle	0 - 0.4V★  SEC986C
			[Engine is running] <ul style="list-style-type: none"> ● Warm-up condition ● Engine speed: 2,500 rpm 	0.1 - 0.6V★  SEC987C
82	B	APP sensor 1 ground	[Engine is running] <ul style="list-style-type: none"> ● Warm-up condition ● Idle speed 	Approximately 0V
83	G	APP sensor 2 ground	[Engine is running] <ul style="list-style-type: none"> ● Warm-up condition ● Idle speed 	Approximately 0V
85	SB	Data link connector	[Ignition switch: ON] <ul style="list-style-type: none"> ● CONSULT-II or GST: Disconnected 	Approximately 5V - Battery voltage (11 - 14V)

TROUBLE DIAGNOSIS

TER-MINAL NO.	WIRE COLOR	ITEM	CONDITION	DATA (DC Voltage)	
86	P	CAN communication line	[Ignition switch: ON]	Approximately 1.1 - 2.3V Output voltage varies with the communication status.	A EC
90	R/V	APP sensor 1 power supply	[Ignition switch: ON]	Approximately 5V	
91	O	APP sensor 2 power supply	[Ignition switch: ON]	Approximately 5V	C
94	L	CAN communication line	[Ignition switch: ON]	Approximately 2.5 - 3.2V Output voltage varies with the communication status.	D
98	W/B	Accelerator pedal position sensor 2	[Ignition switch: ON] ● Engine stopped ● Accelerator pedal: Fully released	0.25 - 0.5V	E
			[Ignition switch: ON] ● Engine stopped ● Accelerator pedal: Fully depressed	2.0 - 2.5V	F
99	G/Y	ASC D steering switch	[Ignition switch: ON] ● ASC D steering switch: OFF	Approximately 4V	G
			[Ignition switch: ON] ● MAIN switch: Pressed	Approximately 0V	H
			[Ignition switch: ON] ● CANCEL switch: Pressed	Approximately 1V	I
			[Ignition switch: ON] ● RESUME/ACCELERATE switch: Pressed	Approximately 3V	J
			[Ignition switch: ON] ● SET/COAST switch: Pressed	Approximately 2V	K
101	R/G	Stop lamp switch	[Ignition switch: OFF] ● Brake pedal: Fully released	Approximately 0V	L
			[Ignition switch: OFF] ● Brake pedal: Slightly depressed	BATTERY VOLTAGE (11 - 14V)	M
102	O/B	PNP switch	[Ignition switch: ON] ● Shift lever: P or N	BATTERY VOLTAGE (11 - 14V)	
			[Ignition switch: ON] ● Except the above gear position	Approximately 0V	
104	O	Throttle control motor relay	[Ignition switch: OFF]	BATTERY VOLTAGE (11 - 14V)	
			[Ignition switch: ON]	0 - 1.0V	
106	W	Accelerator pedal position sensor 1	[Ignition switch: ON] ● Engine stopped ● Accelerator pedal: Fully released	0.5 - 1.0V	
			[Ignition switch: ON] ● Engine stopped ● Accelerator pedal: Fully depressed	4.2 - 4.8V	
107	R/L	Fuel tank temperature sensor	[Engine is running]	Approximately 0 - 4.8V Output voltage varies with fuel tank temperature.	
108	G/B	ASC D brake switch	[Ignition switch: ON] ● Brake pedal: Fully released	BATTERY VOLTAGE (11 - 14V)	
			[Ignition switch: ON] ● Brake pedal: Slightly depressed	Approximately 0V	

TROUBLE DIAGNOSIS

TER-MINAL NO.	WIRE COLOR	ITEM	CONDITION	DATA (DC Voltage)
109	R	Ignition switch	[Ignition switch: OFF]	0V
			[Ignition switch: ON]	BATTERY VOLTAGE (11 - 14V)
111	W/B	ECM relay (Self shut-off)	[Engine is running] [Ignition switch: OFF] ● For a few seconds after turning ignition switch OFF	0 - 1.5V
			[Ignition switch: OFF] ● More than a few seconds after turning ignition switch OFF	BATTERY VOLTAGE (11 - 14V)
113	B/O	Fuel pump relay	[Ignition switch: ON] ● For 1 second after turning ignition switch ON [Engine is running]	0 - 1.5V
			[Ignition switch: ON] ● More than 1 second after turning ignition switch ON	BATTERY VOLTAGE (11 - 14V)
115 116	B B	ECM ground	[Engine is running] ● Idle speed	Body ground
117	LG/B	EVAP canister vent control valve	[Ignition switch: ON]	BATTERY VOLTAGE (11 - 14V)
119 120	R/G R/G	Power supply for ECM	[Ignition switch: ON]	BATTERY VOLTAGE (11 - 14V)
121	G	Power supply for ECM (Back-up)	[Ignition switch: OFF]	BATTERY VOLTAGE (11 - 14V)

★: Average voltage for pulse signal (Actual pulse signal can be confirmed by oscilloscope.)

TROUBLE DIAGNOSIS

CONSULT-II Function (ENGINE) FUNCTION

UBS00P1T

Diagnostic test mode	Function
Work support	This mode enables a technician to adjust some devices faster and more accurately by following the indications on the CONSULT-II unit.
Self-diagnostic results	Self-diagnostic results such as 1st trip DTC, DTCs and 1st trip freeze frame data or freeze frame data can be read and erased quickly.*
Data monitor	Input/Output data in the ECM can be read.
Data monitor (SPEC)	Input/Output of the specification for Basic fuel schedule, AFM, A/F feedback control value and the other data monitor items can be read.
CAN diagnostic support monitor	The results of transmit/receive diagnosis of CAN communication can be read.
Active test	Diagnostic Test Mode in which CONSULT-II drives some actuators apart from the ECMs and also shifts some parameters in a specified range.
DTC & SRT confirmation	The status of system monitoring tests and the self-diagnosis status/result can be confirmed.
Function test	This mode is used to inform customers when their vehicle condition requires periodic maintenance.
ECM part number	ECM part number can be read.

*: The following emission-related diagnostic information is cleared when the ECM memory is erased.

- Diagnostic trouble codes
- 1st trip diagnostic trouble codes
- Freeze frame data
- 1st trip freeze frame data
- System readiness test (SRT) codes
- Test values

A
EC
C
D
E
F
G
H
I
J
K
L
M

TROUBLE DIAGNOSIS

ENGINE CONTROL COMPONENT PARTS/CONTROL SYSTEMS APPLICATION

Item		DIAGNOSTIC TEST MODE							
		WORK SUP-PORT	SELF-DIAGNOSTIC RESULTS		DATA MONI-TOR	DATA MONI-TOR (SPEC)	ACTIVE TEST	DTC & SRT CONFIRMATION	
			DTC*1	FREEZE FRAME DATA*2				SRT STATUS	DTC WORK SUP-PORT
ENGINE CONTROL COMPONENT PARTS INPUT	Crankshaft position sensor (POS)		×	×	×	×			
	Camshaft position sensor (PHASE)		×	×	×	×			
	Mass air flow sensor		×		×	×			
	Engine coolant temperature sensor		×	×	×	×	×		
	A/F sensor 1		×		×	×		×	×
	Heated oxygen sensor 2		×		×	×		×	×
	Wheel sensor		×	×	×	×			
	Accelerator pedal position sensor		×		×	×			
	Throttle position sensor		×	×	×	×			
	Fuel tank temperature sensor		×		×	×	×		
	EVAP control system pressure sensor		×		×	×			
	Intake air temperature sensor		×	×	×	×			
	EGR temperature sensor		×		×	×			
	Knock sensor		×						
	Refrigerant pressure sensor				×	×			
	Closed throttle position switch (accelerator pedal position sensor signal)				×	×			
	Air conditioner switch				×	×			
	Park/neutral position (PNP) switch		×		×	×			
	Stop lamp switch		×		×	×			
	Power steering pressure sensor		×		×	×			
Battery voltage				×	×				
Load signal				×	×				
Fuel level sensor		×		×	×				
ASCD steering switch		×		×	×				
ASCD brake switch		×		×	×				

TROUBLE DIAGNOSIS

Item		DIAGNOSTIC TEST MODE							
		WORK SUP-PORT	SELF-DIAGNOSTIC RESULTS		DATA MONI-TOR	DATA MONI-TOR (SPEC)	ACTIVE TEST	DTC & SRT CONFIRMATION	
			DTC*1	FREEZE FRAME DATA*2				SRT STATUS	DTC WORK SUP-PORT
ENGINE CONTROL COMPONENT PARTS OUTPUT	Fuel injector				×	×	×		
	Power transistor (Ignition timing)				×	×	×		
	Throttle control motor relay		×		×	×			
	Throttle control motor		×						
	EVAP canister purge volume control solenoid valve		×		×	×	×		×
	Air conditioner relay				×	×			
	Fuel pump relay	×			×	×	×		
	Cooling fan relay		×		×	×	×		
	EGR volume control valve		×		×	×	×		
	A/F sensor 1 heater		×		×	×		×*3	
	Heated oxygen sensor 2 heater		×		×	×		×*3	
	EVAP canister vent control valve	×	×		×	×	×		
	Intake valve timing control solenoid valve		×		×	×	×		
	VIAS control solenoid valve		×		×	×	×		
	Electronic controlled engine mount				×	×	×		
Calculated load value			×	×	×				

X: Applicable

*1: This item includes 1st trip DTCs.

*2: This mode includes 1st trip freeze frame data or freeze frame data. The items appear on CONSULT-II screen in freeze frame data mode only if a 1st trip DTC or DTC is detected. For details, refer to [EC-53](#).

*3: Always "COMPLT" is displayed.

INSPECTION PROCEDURE

Refer to [GI-39, "CONSULT-II Data Link Connector \(DLC\) Circuit"](#).

WORK SUPPORT MODE

Work Item

WORK ITEM	CONDITION	USAGE
FUEL PRESSURE RELEASE	<ul style="list-style-type: none"> FUEL PUMP WILL STOP BY TOUCHING "START" DURING IDLING. CRANK A FEW TIMES AFTER ENGINE STALLS. 	When releasing fuel pressure from fuel line
IDLE AIR VOL LEARN	<ul style="list-style-type: none"> THE IDLE AIR VOLUME THAT KEEPS THE ENGINE WITHIN THE SPECIFIED RANGE IS MEMORIZED IN ECM. 	When learning the idle air volume
SELF-LEARNING CONT	<ul style="list-style-type: none"> THE COEFFICIENT OF SELF-LEARNING CONTROL MIXTURE RATIO RETURNS TO THE ORIGINAL COEFFICIENT. 	When clearing the coefficient of self-learning control value

TROUBLE DIAGNOSIS

WORK ITEM	CONDITION	USAGE
EVAP SYSTEM CLOSE	<p>CLOSE THE EVAP CANISTER VENT CONTROL VALVE IN ORDER TO MAKE EVAP SYSTEM CLOSE UNDER THE FOLLOWING CONDITIONS.</p> <ul style="list-style-type: none"> ● IGN SW "ON" ● ENGINE NOT RUNNING ● AMBIENT TEMPERATURE IS ABOVE 0°C (32°F). ● NO VACUUM AND NO HIGH PRESSURE IN EVAP SYSTEM ● FUEL TANK TEMP. IS MORE THAN 0°C (32°F). ● WITHIN 10 MINUTES AFTER STARTING "EVAP SYSTEM CLOSE" ● WHEN TRYING TO EXECUTE "EVAP SYSTEM CLOSE" UNDER THE CONDITION EXCEPT ABOVE, CONSULT-II WILL DISCONTINUE IT AND DISPLAY APPROPRIATE INSTRUCTION. <p>NOTE: WHEN STARTING ENGINE, CONSULT-II MAY DISPLAY "BATTERY VOLTAGE IS LOW. CHARGE BATTERY", EVEN IN USING CHARGED BATTERY.</p>	When detecting EVAP vapor leak point of EVAP system
TARGET IDLE RPM ADJ*	<ul style="list-style-type: none"> ● IDLE CONDITION 	When setting target idle speed
TARGET IGN TIM ADJ*	<ul style="list-style-type: none"> ● IDLE CONDITION 	When adjusting target ignition timing
VIN REGISTRATION	<ul style="list-style-type: none"> ● IN THIS MODE, VIN IS REGISTERED IN ECM. 	When registering VIN in ECM

*: This function is not necessary in the usual service procedure.

SELF-DIAG RESULTS MODE

Self Diagnostic Item

Regarding items of DTC and 1st trip DTC, refer to [EC-49, "EMISSION-RELATED DIAGNOSTIC INFORMATION ITEMS"](#) .)

Freeze Frame Data and 1st Trip Freeze Frame Data

Freeze frame data item*	Description
DIAG TROUBLE CODE [PXXXX]	<ul style="list-style-type: none"> ● The engine control component part/control system has a trouble code, it is displayed as PXXXX. (Refer to EC-8, "INDEX FOR DTC" .)
FUEL SYS-B1	<ul style="list-style-type: none"> ● "Fuel injection system status" at the moment a malfunction is detected is displayed.
FUEL SYS-B2	<ul style="list-style-type: none"> ● One mode in the following is displayed. Mode2: Open loop due to detected system malfunction Mode3: Open loop due to driving conditions (power enrichment, deceleration enrichment) Mode4: Closed loop - using oxygen sensor(s) as feedback for fuel control Mode5: Open loop - has not yet satisfied condition to go to closed loop
CAL/LD VALUE [%]	<ul style="list-style-type: none"> ● The calculated load value at the moment a malfunction is detected is displayed.
COOLANT TEMP [°C] or [°F]	<ul style="list-style-type: none"> ● The engine coolant temperature at the moment a malfunction is detected is displayed.
L-FUEL TRM-B1 [%]	<ul style="list-style-type: none"> ● "Long-term fuel trim" at the moment a malfunction is detected is displayed.
L-FUEL TRM-B2 [%]	<ul style="list-style-type: none"> ● The long-term fuel trim indicates much more gradual feedback compensation to the base fuel schedule than short-term fuel trim.
S-FUEL TRM-B1 [%]	<ul style="list-style-type: none"> ● "Short-term fuel trim" at the moment a malfunction is detected is displayed.
S-FUEL TRM-B2 [%]	<ul style="list-style-type: none"> ● The short-term fuel trim indicates dynamic or instantaneous feedback compensation to the base fuel schedule.
ENGINE SPEED [rpm]	<ul style="list-style-type: none"> ● The engine speed at the moment a malfunction is detected is displayed.
VEHICL SPEED [km/h] or [mph]	<ul style="list-style-type: none"> ● The vehicle speed at the moment a malfunction is detected is displayed.

TROUBLE DIAGNOSIS

Freeze frame data item*	Description
ABSOL TH-P/S [%]	● The throttle valve opening angle at the moment a malfunction is detected is displayed.
B/FUEL SCHDL [msec]	● The base fuel schedule at the moment a malfunction is detected is displayed.
INT/A TEMP SE [°C] or [°F]	● The intake air temperature at the moment a malfunction is detected is displayed.

*: The items are the same as those of 1st trip freeze frame data.

DATA MONITOR MODE

Monitored Item

×: Applicable

Monitored item [Unit]	ECM INPUT SIGNALS	MAIN SIGNALS	Description	Remarks
ENG SPEED [rpm]	×	×	● Indicates the engine speed computed from the signal of the crankshaft position sensor (POS) and camshaft position sensor (PHASE).	● Accuracy becomes poor if engine speed drops below the idle rpm. ● If the signal is interrupted while the engine is running, an abnormal value may be indicated.
MAS A/F SE-B1 [V]	×	×	● The signal voltage of the mass air flow sensor is displayed.	● When the engine is stopped, a certain value is indicated.
B/FUEL SCHDL [msec]		×	● "Base fuel schedule" indicates the fuel injection pulse width programmed into ECM, prior to any learned on board correction.	
A/F ALPHA-B1 [%]		×	● The mean value of the air-fuel ratio feedback correction factor per cycle is indicated.	● When the engine is stopped, a certain value is indicated.
A/F ALPHA-B2 [%]		×		● This data also includes the data for the air-fuel ratio learning control.
COOLAN TEMP/S [°C] or [°F]	×	×	● The engine coolant temperature (determined by the signal voltage of the engine coolant temperature sensor) is displayed.	● When the engine coolant temperature sensor is open or short-circuited, ECM enters fail-safe mode. The engine coolant temperature determined by the ECM is displayed.
A/F SEN1 (B1) [V]	×	×	● The A/F signal computed from the input signal of the A/F sensor 1 is displayed.	
A/F SEN1 (B2) [V]	×			
HO2S2 (B1) [V]	×		● The signal voltage of the heated oxygen sensor 2 is displayed.	
HO2S2 (B2) [V]	×			
HO2S2 MNTR (B1) [RICH/LEAN]	×		● Display of heated oxygen sensor 2 signal: RICH: means the amount of oxygen after three way catalyst is relatively small. LEAN: means the amount of oxygen after three way catalyst is relatively large.	● When the engine is stopped, a certain value is indicated.
HO2S2 MNTR (B2) [RICH/LEAN]	×			
VHCL SPEED SE [km/h] or [mph]	×	×	● The vehicle speed computed from the vehicle speed signal sent from combination meter is displayed.	
BATTERY VOLT [V]	×	×	● The power supply voltage of ECM is displayed.	
ACCEL SEN 1 [V]	×	×	● The accelerator pedal position sensor signal voltage is displayed.	● ACCEL SEN 2 signal is converted by ECM internally. Thus, it differs from ECM terminal voltage signal.
ACCEL SEN 2 [V]	×			

TROUBLE DIAGNOSIS

Monitored item [Unit]	ECM INPUT SIG- NALS	MAIN SIG- NALS	Description	Remarks
THRTL SEN 1 [V]	×	×	● The throttle position sensor signal voltage is displayed.	● THRTL SEN 2 signal is converted by ECM internally. Thus, it differs from ECM terminal voltage signal.
THRTL SEN 2 [V]	×			
FUEL T/TMP SE [°C] or [°F]	×		● The fuel temperature (determined by the signal voltage of the fuel tank temperature sensor) is displayed.	
INT/A TEMP SE [°C] or [°F]	×	×	● The intake air temperature (determined by the signal voltage of the intake air temperature sensor) is indicated.	
EGR TEMP SEN [V]	×	×	● The signal voltage of EGR temperature sensor is displayed.	
EVAP SYS PRES [V]	×		● The signal voltage of EVAP control system pressure sensor is displayed.	
FUEL LEVEL SE [V]	×		● The signal voltage of the fuel level sensor is displayed.	
START SIGNAL [ON/OFF]	×	×	● Indicates start signal status [ON/OFF] computed by the ECM according to the signals of engine speed and battery voltage.	● After starting the engine, [OFF] is displayed regardless of the starter signal.
CLSD THL POS [ON/OFF]	×	×	● Indicates idle position [ON/OFF] computed by ECM according to the accelerator pedal position sensor signal.	
AIR COND SIG [ON/OFF]	×	×	● Indicates [ON/OFF] condition of the air conditioner switch as determined by the air conditioner signal.	
P/N POSI SW [ON/OFF]	×	×	● Indicates [ON/OFF] condition from the park/neutral position (PNP) switch signal.	
PW/ST SIGNAL [ON/OFF]	×	×	● [ON/OFF] condition of the power steering system (determined by the signal voltage of the power steering pressure sensor signal) is indicated.	
LOAD SIGNAL [ON/OFF]	×	×	● Indicates [ON/OFF] condition from the electrical load signal. ON: Rear window defogger switch is ON and/or lighting switch is in 2nd position. OFF: Both rear window defogger switch and lighting switch are OFF.	
IGNITION SW [ON/OFF]	×		● Indicates [ON/OFF] condition from ignition switch signal.	
HEATER FAN SW [ON/OFF]	×		● Indicates [ON/OFF] condition from heater fan switch signal.	
BRAKE SW [ON/OFF]	×		● Indicates [ON/OFF] condition from the stop lamp switch signal.	
INJ PULSE-B1 [msec]		×	● Indicates the actual fuel injection pulse width compensated by ECM according to the input signals.	● When the engine is stopped, a certain computed value is indicated.
INJ PULSE-B2 [msec]				
IGN TIMING [BTDC]		×	● Indicates the ignition timing computed by ECM according to the input signals.	● When the engine is stopped, a certain value is indicated.
CAL/LD VALUE [%]			● "Calculated load value" indicates the value of the current air flow divided by peak air flow.	

TROUBLE DIAGNOSIS

Monitored item [Unit]	ECM INPUT SIG- NALS	MAIN SIG- NALS	Description	Remarks	
MASS AIRFLOW [g·m/s]			<ul style="list-style-type: none"> Indicates the mass air flow computed by ECM according to the signal voltage of the mass air flow sensor. 		EC
PURG VOL C/V [%]			<ul style="list-style-type: none"> Indicates the EVAP canister purge volume control solenoid valve control value computed by the ECM according to the input signals. The opening becomes larger as the value increases. 		C
EGR VOL CON/V [step]		×	<ul style="list-style-type: none"> Indicates the EGR volume control value computed by the ECM according to the input signals. The opening becomes larger as the value increases. 		D
INT/V TIM (B1) [°CA]			<ul style="list-style-type: none"> Indicates [°CA] of intake camshaft advanced angle. 		E
INT/V TIM (B2) [°CA]				F	
INT/V SOL (B1) [%]			<ul style="list-style-type: none"> The control value of the intake valve timing control solenoid valve (determined by ECM according to the input signals) is indicated. The advance angle becomes larger as the value increases. 		G
INT/V SOL (B2) [%]				H	
VIAS S/V [ON/OFF]			<ul style="list-style-type: none"> The control condition of the VIAS control solenoid valve (determined by ECM according to the input signals) is indicated. ON: VIAS control solenoid valve is operating. OFF: VIAS control solenoid valve is not operating. 		I
AIR COND RLY [ON/OFF]		×	<ul style="list-style-type: none"> The air conditioner relay control condition (determined by ECM according to the input signals) is indicated. 		J
ENGINE MOUNT [IDLE/TRVL]			<ul style="list-style-type: none"> The control condition of the electronic controlled engine mount (determined by ECM according to the input signals) is indicated. IDLE: Engine speed is below 950 rpm TRVL: Engine speed is above 950 rpm 		K
FUEL PUMP RLY [ON/OFF]		×	<ul style="list-style-type: none"> Indicates the fuel pump relay control condition determined by ECM according to the input signals. 		L
VENT CONT/V [ON/OFF]			<ul style="list-style-type: none"> The control condition of the EVAP canister vent control valve (determined by ECM according to the input signals) is indicated. ON: Closed OFF: Open 		M
THRTL RELAY [ON/OFF]		×	<ul style="list-style-type: none"> Indicates the throttle control motor relay control condition determined by the ECM according to the input signals. 		

TROUBLE DIAGNOSIS

Monitored item [Unit]	ECM INPUT SIG- NALS	MAIN SIG- NALS	Description	Remarks
COOLING FAN [HI/MID/LOW/OFF]			<ul style="list-style-type: none"> The control condition of the cooling fan (determined by ECM according to the input signals) is indicated. HI: High speed operation MID: Middle speed operation LOW: Low speed operation OFF: Stop 	
HO2S2 HTR (B1) [ON/OFF]			<ul style="list-style-type: none"> Indicates [ON/OFF] condition of heated oxygen sensor 2 heater determined by ECM according to the input signals. 	
HO2S2 HTR (B2) [ON/OFF]				
I/P PULLY SPD [rpm]			<ul style="list-style-type: none"> Indicates the engine speed computed from the turbine revolution sensor signal. 	
VEHICLE SPEED [km/h] or [MPH]			<ul style="list-style-type: none"> Indicates the vehicle speed computed from the revolution sensor signal. 	
IDL A/V LEARN [YET/CMPLT]			<ul style="list-style-type: none"> Display the condition of idle air volume learning YET: Idle air volume learning has not been performed yet. CMPLT: Idle air volume learning has already been performed successfully. 	
TRVL AFTER MIL [km] or [mile]			<ul style="list-style-type: none"> Distance traveled while MIL is activated. 	
A/F S1 HTR (B1) [%]			<ul style="list-style-type: none"> Indicates A/F sensor 1 heater control value computed by ECM according to the input signals. The current flow to the heater becomes larger as the value increases. 	
A/F S1 HTR (B2) [%]				
AC PRESS SEN [V]			<ul style="list-style-type: none"> The signal voltage from the refrigerant pressure sensor is displayed. 	
VHCL SPEED SE [km/h] or [mph]			<ul style="list-style-type: none"> The vehicle speed computed from the vehicle speed signal sent from TCM is displayed. 	
SET VHCL SPD [km/h] or [m.p.h.]			<ul style="list-style-type: none"> The preset vehicle speed is displayed. 	
MAIN SW [ON/OFF]			<ul style="list-style-type: none"> Indicates [ON/OFF] condition from MAIN switch signal. 	
CANCEL SW [ON/OFF]			<ul style="list-style-type: none"> Indicates [ON/OFF] condition from CANCEL switch signal. 	
RESUME/ACC SW [ON/OFF]			<ul style="list-style-type: none"> Indicates [ON/OFF] condition from RESUME/ACCELERATE switch signal. 	
SET SW [ON/OFF]			<ul style="list-style-type: none"> Indicates [ON/OFF] condition from SET/COAST switch signal. 	
BRAKE SW1 [ON/OFF]			<ul style="list-style-type: none"> Indicates [ON/OFF] condition from ASCD brake switch signal. 	
BRAKE SW2 [ON/OFF]			<ul style="list-style-type: none"> Indicates [ON/OFF] condition of stop lamp switch signal. 	
VHCL SPD CUT [NON/CUT]			<ul style="list-style-type: none"> Indicates the vehicle cruise condition. NON: Vehicle speed is maintained at the ASCD set speed. CUT: Vehicle speed increased to excessively high compared with the ASCD set speed, and ASCD operation is cut off. 	

TROUBLE DIAGNOSIS

Monitored item [Unit]	ECM INPUT SIGNALS	MAIN SIGNALS	Description	Remarks
LO SPEED CUT [NON/CUT]			<ul style="list-style-type: none"> Indicates the vehicle cruise condition. NON: Vehicle speed is maintained at the ASCD set speed. CUT: Vehicle speed decreased to excessively low compared with the ASCD set speed, and ASCD operation is cut off. 	
AT OD MONITOR [ON/OFF]			<ul style="list-style-type: none"> Indicates [ON/OFF] condition of A/T O/D according to the input signal from the TCM. 	
AT OD CANCEL [ON/OFF]			<ul style="list-style-type: none"> Indicates [ON/OFF] condition of A/T O/D cancel signal sent from the TCM. 	
CRUISE LAMP [ON/OFF]			<ul style="list-style-type: none"> Indicates [ON/OFF] condition of CRUISE lamp determined by the ECM according to the input signals. 	
SET LAMP [ON/OFF]			<ul style="list-style-type: none"> Indicates [ON/OFF] condition of SET lamp determined by the ECM according to the input signals. 	
A/F ADJ-B1			<ul style="list-style-type: none"> Indicates the correction factor stored in ECM. The factor is calculated from the difference between the target air-fuel ratio stored in ECM and the air-fuel ratio calculated from A/F sensor 1 signal. 	
A/F ADJ-B2				
Voltage [V]			<ul style="list-style-type: none"> Voltage, frequency, duty cycle or pulse width measured by the probe. 	<ul style="list-style-type: none"> Only “#” is displayed if item is unable to be measured. Figures with “#”s are temporary ones. They are the same figures as an actual piece of data which was just previously measured.
Frequency [msec], [Hz] or [%]				
DUTY-HI				
DUTY-LOW				
PLS WIDTH-HI				
PLS WIDTH-LOW				

NOTE:

Any monitored item that does not match the vehicle being diagnosed is deleted from the display automatically.

DATA MONITOR (SPEC) MODE

Monitored Item

Monitored item [Unit]	ECM INPUT SIGNALS	MAIN SIGNALS	Description	Remarks
ENG SPEED [rpm]	×	×	<ul style="list-style-type: none"> Indicates the engine speed computed from the signal of the crankshaft position sensor (POS) and camshaft position sensor (PHASE). 	
MAS A/F SE-B1 [V]	×	×	<ul style="list-style-type: none"> The signal voltage of the mass air flow sensor specification is displayed. 	<ul style="list-style-type: none"> When engine is running specification range is indicated.
B/FUEL SCHDL [msec]		×	<ul style="list-style-type: none"> “Base fuel schedule” indicates the fuel injection pulse width programmed into ECM, prior to any learned on board correction. 	<ul style="list-style-type: none"> When engine is running specification range is indicated.
A/F ALPHA-B1 [%] A/F ALPHA-B2 [%]		×	<ul style="list-style-type: none"> The mean value of the air-fuel ratio feedback correction factor per cycle is indicated. 	<ul style="list-style-type: none"> When engine is running specification range is indicated. This data also includes the data for the air-fuel ratio learning control.

TROUBLE DIAGNOSIS

NOTE:

Any monitored item that does not match the vehicle being diagnosed is deleted from the display automatically.

ACTIVE TEST MODE

Test Item

TEST ITEM	CONDITION	JUDGEMENT	CHECK ITEM (REMEDY)
FUEL INJECTION	<ul style="list-style-type: none"> ● Engine: Return to the original trouble condition ● Change the amount of fuel injection using CONSULT-II. 	If trouble symptom disappears, see CHECK ITEM.	<ul style="list-style-type: none"> ● Harness and connectors ● Fuel injector ● A/F sensor 1
IGNITION TIMING	<ul style="list-style-type: none"> ● Engine: Return to the original trouble condition ● Timing light: Set ● Retard the ignition timing using CONSULT-II. 	If trouble symptom disappears, see CHECK ITEM.	<ul style="list-style-type: none"> ● Perform Idle Air Volume Learning
POWER BALANCE	<ul style="list-style-type: none"> ● Engine: After warming up, idle the engine. ● A/C switch: OFF ● Shift lever: P or N ● Cut off each fuel injector signal one at a time using CONSULT-II. 	Engine runs rough or dies.	<ul style="list-style-type: none"> ● Harness and connectors ● Compression ● Fuel injector ● Power transistor ● Spark plug ● Ignition coil
COOLING FAN*	<ul style="list-style-type: none"> ● Ignition switch: ON ● Turn the cooling fan "HI", "MID", "LOW" and "OFF" using CONSULT-II. 	Cooling fan moves and stops.	<ul style="list-style-type: none"> ● Harness and connectors ● Cooling fan motor ● IPDM E/R
ENG COOLANT TEMP	<ul style="list-style-type: none"> ● Engine: Return to the original trouble condition ● Change the engine coolant temperature using CONSULT-II. 	If trouble symptom disappears, see CHECK ITEM.	<ul style="list-style-type: none"> ● Harness and connectors ● Engine coolant temperature sensor ● Fuel injector
FUEL PUMP RELAY	<ul style="list-style-type: none"> ● Ignition switch: ON (Engine stopped) ● Turn the fuel pump relay "ON" and "OFF" using CONSULT-II and listen to operating sound. 	Fuel pump relay makes the operating sound.	<ul style="list-style-type: none"> ● Harness and connectors ● Fuel pump relay
EGR VOL CONT/V	<ul style="list-style-type: none"> ● Ignition switch: ON (Engine stopped) ● Change the EGR volume control valve opening step using CONSULT-II. 	EGR volume control valve makes an operating sound.	<ul style="list-style-type: none"> ● Harness and connectors ● EGR volume control valve
VIAS SOL VALVE	<ul style="list-style-type: none"> ● Ignition switch: ON ● Turn solenoid valve "ON" and "OFF" using CONSULT-II and listen to operating sound. 	Solenoid valve makes the operating sound.	<ul style="list-style-type: none"> ● Harness and connectors ● Solenoid valve
ENGINE MOUNTING	<ul style="list-style-type: none"> ● Ignition switch: ON ● Turn electronic controlled engine mount "IDLE" and "TRVL" with the CONSULT-II. 	Electronic controlled engine mount makes the operating sound.	<ul style="list-style-type: none"> ● Harness and connectors ● Electronic controlled engine mount
PURG VOL CONT/V	<ul style="list-style-type: none"> ● Engine: After warming up, run engine at 1,500 rpm. ● Change the EVAP canister purge volume control solenoid valve opening percent using CONSULT-II. 	Engine speed changes according to the opening percent.	<ul style="list-style-type: none"> ● Harness and connectors ● Solenoid valve
FUEL/T TEMP SEN	<ul style="list-style-type: none"> ● Change the fuel tank temperature using CONSULT-II. 		

TROUBLE DIAGNOSIS

TEST ITEM	CONDITION	JUDGEMENT	CHECK ITEM (REMEDY)
VENT CONTROL/V	<ul style="list-style-type: none"> Ignition switch: ON (Engine stopped) Turn solenoid valve "ON" and "OFF" with the CONSULT-II and listen to operating sound. 	Solenoid valve makes an operating sound.	<ul style="list-style-type: none"> Harness and connectors Solenoid valve
V/T ASSIGN ANGLE	<ul style="list-style-type: none"> Engine: Return to the original trouble condition Change intake valve timing using CONSULT-II. 	If trouble symptom disappears, see CHECK ITEM.	<ul style="list-style-type: none"> Harness and connectors Intake valve timing control solenoid valve

*: Leaving cooling fan "OFF" with CONSULT-II while engine is running may cause the engine to overheat.

DTC & SRT CONFIRMATION MODE

SRT STATUS Mode

For details, refer to [EC-54, "SYSTEM READINESS TEST \(SRT\) CODE"](#) .

SRT WORK SUPPORT Mode

This mode enables a technician to drive a vehicle to set the SRT while monitoring the SRT status.

DTC WORK SUPPORT Mode

Test mode	Test item	Corresponding DTC No.	Reference page
EVAPORATIVE SYSTEM	PURG FLOW P0441	P0441	EC-425
	EVP SML LEAK P0442/P1442*	P0442	EC-431
		P0455	EC-487
	EVP V/S LEAK P0456/P1456*	P0456	EC-495
	PURG VOL CN/V P1444	P0443	EC-439
A/F SEN1	A/F SEN1 (B1) P1276	P0130	EC-239
	A/F SEN1 (B1) P1278/P1279	P0133	EC-270
	A/F SEN1 (B2) P1286	P0150	EC-239
	A/F SEN1 (B2) P1288/P1289	P0153	EC-270
HO2S2	HO2S2 (B1) P0139	P0139	EC-310
	HO2S2 (B1) P1146	P0138	EC-295
	HO2S2 (B1) P1147	P0137	EC-283
	HO2S2 (B2) P0159	P0159	EC-310
	HO2S2 (B2) P1166	P0158	EC-295
	HO2S2 (B2) P1167	P0157	EC-283
EGR SYSTEM	EGR SYSTEM P0400	P0400	EC-397
	EGR SYSTEM P1402	P1402	EC-559

*: DTC P1442 and P1456 does not apply to V42 models but appears in DTC Work Support Mode screens.

TROUBLE DIAGNOSIS

REAL TIME DIAGNOSIS IN DATA MONITOR MODE (RECORDING VEHICLE DATA)

Description

CONSULT-II has two kinds of triggers and they can be selected by touching "SETTING" in "DATA MONITOR" mode.

1. "AUTO TRIG" (Automatic trigger):

- The malfunction will be identified on the CONSULT-II screen in real time.

In other words, DTC/1st trip DTC and malfunction item will be displayed if the malfunction is detected by ECM.

At the moment a malfunction is detected by ECM, "MONITOR" in "DATA MONITOR" screen is changed to "Recording Data ... xx%" as shown in the figure, and the data after the malfunction detection is recorded. Then when the percentage reached 100%, "REAL-TIME DIAG" screen is displayed. If "STOP" is touched on the screen during "Recording Data ... xx%", "REAL-TIME DIAG" screen is also displayed.

The recording time after the malfunction detection and the recording speed can be changed by "TRIGGER POINT" and "Recording Speed". Refer to CONSULT-II OPERATION MANUAL.

2. "MANU TRIG" (Manual trigger):

- DTC/1st trip DTC and malfunction item will not be displayed automatically on CONSULT-II screen even though a malfunction is detected by ECM.

DATA MONITOR can be performed continuously even though a malfunction is detected.

DATA MONITOR	
Recording Data...11%	NO DTC
ENG SPEED	XXX rpm
MAS A/F SE-B1	XXX V
COOLAN TEMP/S	XXX °C
A/F SEN1 (B1)	XXX V
VHCL SPEED SE	XXX km/h

PB1B1593E

SET RECORDING CONDITION	
AUTO TRIG	
MANU TRIG	
TRIGGER POINT	
<div style="display: flex; justify-content: space-between; align-items: center;"> <div style="width: 80%; border: 1px solid black; position: relative;"> <div style="position: absolute; top: -10px; left: 0; right: 0; text-align: center; font-size: 8px;">0% 20% 40% 60% 80% 100%</div> </div> </div>	
RECORDING SPEED	
MIN	MAX
/64 /32 /16 /8 /4 /2 FULL	

SEF707X

TROUBLE DIAGNOSIS

Operation

1. "AUTO TRIG"

- While trying to detect the DTC/1st trip DTC by performing the DTC Confirmation Procedure, be sure to select to "DATA MONITOR (AUTO TRIG)" mode. You can confirm the malfunction at the moment it is detected.
- While narrowing down the possible causes, CONSULT-II should be set in "DATA MONITOR (AUTO TRIG)" mode, especially in case the incident is intermittent. When you are inspecting the circuit by gently shaking (or twisting) the suspicious connectors, components and harness in the "DTC Confirmation Procedure", the moment a malfunction is found the DTC/1st trip DTC will be displayed. (Refer to "INCIDENT SIMULATION TESTS" in [GI-26, "How to Perform Efficient Diagnosis for an Electrical Incident"](#) .)

2. "MANU TRIG"

- If the malfunction is displayed as soon as "DATA MONITOR" is selected, reset CONSULT-II to "MANU TRIG". By selecting "MANU TRIG" you can monitor and store the data. The data can be utilized for further diagnosis, such as a comparison with the value for the normal operating condition.

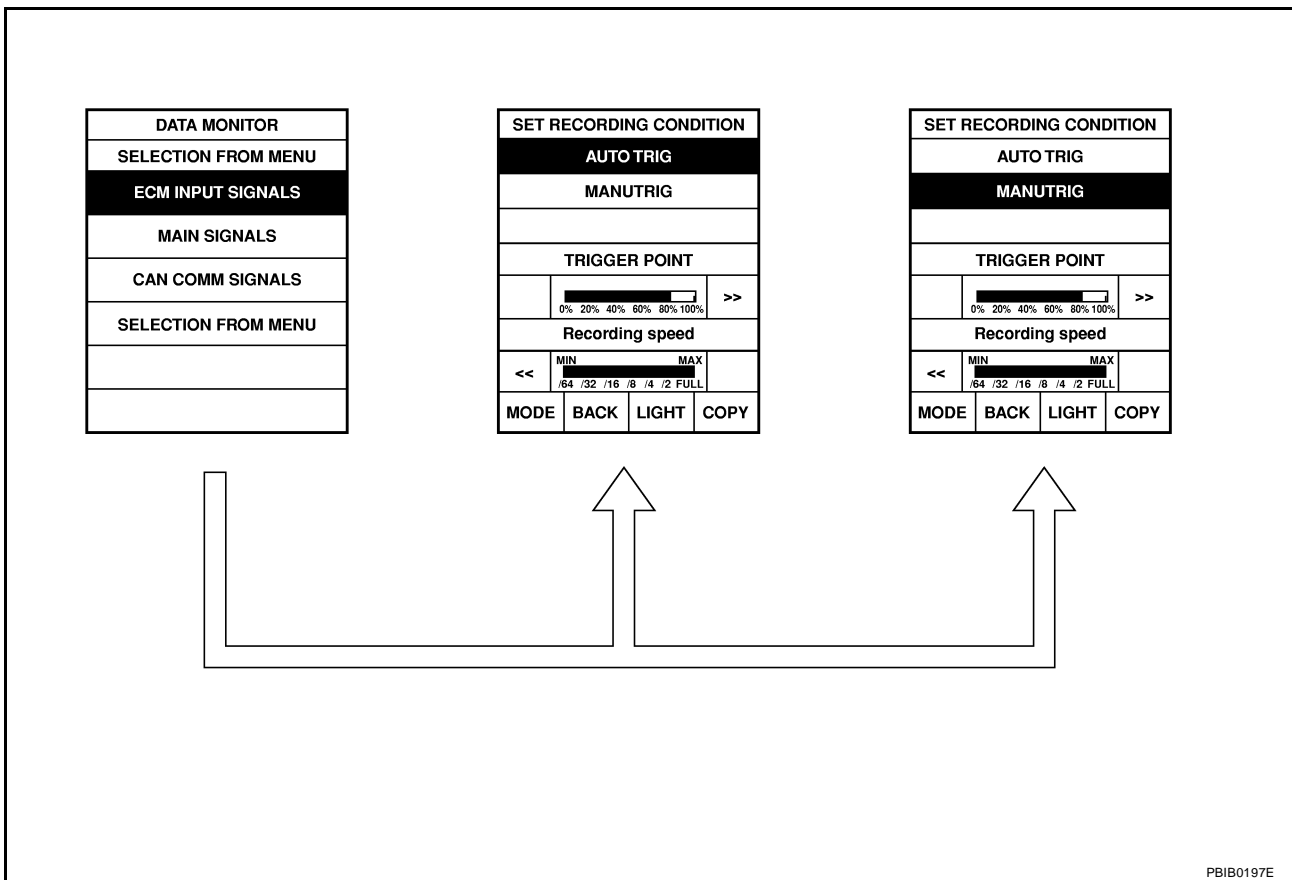

Generic Scan Tool (GST) Function DESCRIPTION

UBS00P1U

Generic Scan Tool (OBDII scan tool) complying with SAE J1978 has 8 different functions explained below. ISO9141 is used as the protocol. The name "GST" or "Generic Scan Tool" is used in this service manual.

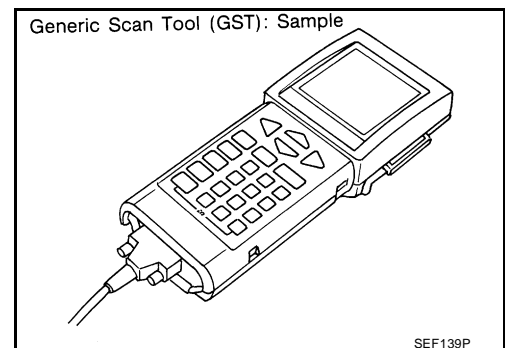

TROUBLE DIAGNOSIS

FUNCTION

Diagnostic test mode		Function
Service \$01	READINESS TESTS	This diagnostic service gains access to current emission-related data values, including analog inputs and outputs, digital inputs and outputs, and system status information.
Service \$02	(FREEZE DATA)	This diagnostic service gains access to emission-related data value which were stored by ECM during the freeze frame. For details, refer to EC-122, "Freeze Frame Data and 1st Trip Freeze Frame Data" .
Service \$03	DTCs	This diagnostic service gains access to emission-related power train trouble codes which were stored by ECM.
Service \$04	CLEAR DIAG INFO	This diagnostic service can clear all emission-related diagnostic information. This includes: <ul style="list-style-type: none"> ● Clear number of diagnostic trouble codes (Service \$01) ● Clear diagnostic trouble codes (Service \$03) ● Clear trouble code for freeze frame data (Service \$01) ● Clear freeze frame data (Service \$02) ● Reset status of system monitoring test (Service \$01) ● Clear on board monitoring test results (Service \$06 and \$07)
Service \$06	(ON BOARD TESTS)	This diagnostic service accesses the results of on board diagnostic monitoring tests of specific components/systems that are not continuously monitored.
Service \$07	(ON BOARD TESTS)	This diagnostic service enables the off board test drive to obtain test results for emission-related powertrain components/systems that are continuously monitored during normal driving conditions.
Service \$08	—	This diagnostic service can close EVAP system in ignition switch ON position (Engine stopped). When this diagnostic service is performed, EVAP canister vent control valve can be closed. In the following conditions, this diagnostic service cannot function. <ul style="list-style-type: none"> ● Low ambient temperature ● Low battery voltage ● Engine running ● Ignition switch OFF ● Low fuel temperature ● Too much pressure is applied to EVAP system
Service \$09	(CALIBRATION ID)	This diagnostic service enables the off-board test device to request specific vehicle information such as Vehicle Identification Number (VIN) and Calibration IDs.

INSPECTION PROCEDURE

1. Turn ignition switch OFF.
2. Connect GST to data link connector (2), which is located under LH dash panel near the hood opener handle.
 - Brake pedal (1)
3. Turn ignition switch ON.

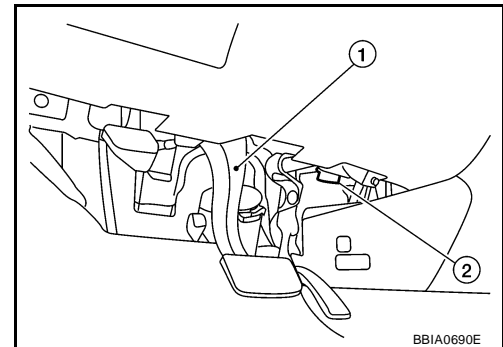

TROUBLE DIAGNOSIS

4. Enter the program according to instruction on the screen or in the operation manual.
(*: Regarding GST screens in this section, sample screens are shown.)

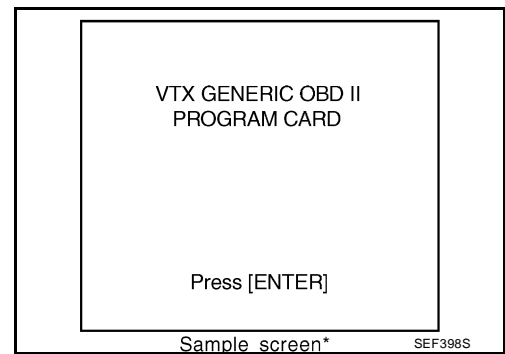

A

EC

C

5. Perform each diagnostic service according to each service procedure.
For further information, see the GST Operation Manual of the tool maker.

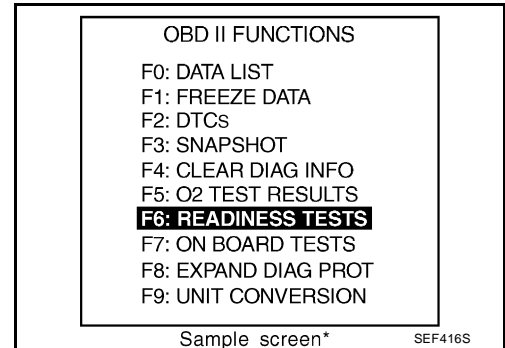

D

E

F

G

H

I

J

K

L

M

TROUBLE DIAGNOSIS

UBS00P1V

CONSULT-II Reference Value in Data Monitor

Remarks:

● Specification data are reference values.

● Specification data are output/input values which are detected or supplied by the ECM at the connector.

* Specification data may not be directly related to their components signals/values/operations.

i.e. Adjust ignition timing with a timing light before monitoring IGN TIMING, because the monitor may show the specification data in spite of the ignition timing not being adjusted to the specification data. This IGN TIMING monitors the data calculated by the ECM according to the signals input from the camshaft position sensor and other ignition timing related sensors.

MONITOR ITEM	CONDITION		SPECIFICATION
ENG SPEED	● Run engine and compare CONSULT-II value with the tachometer indication.		Almost the same speed as the tachometer indication.
MAS A/F SE-B1	● See EC-139, "TROUBLE DIAGNOSIS - SPECIFICATION VALUE" .		
B/FUEL SCHDL	● See EC-139, "TROUBLE DIAGNOSIS - SPECIFICATION VALUE" .		
A/F ALPHA-B1 A/F ALPHA-B2	● See EC-139, "TROUBLE DIAGNOSIS - SPECIFICATION VALUE" .		
COOLAN TEMP/S	● Engine: After warming up		More than 70°C (158°F)
A/F SEN1 (B1) A/F SEN1 (B2)	● Engine: After warming up	Maintaining engine speed at 2,000 rpm	Fluctuates around 1.5V
HO2S2 (B1) HO2S2 (B2)	● Revving engine from idle to 3,000 rpm quickly after the following conditions are met		0 - 0.3V ↔ Approx. 0.6 - 1.0V
HO2S2 MNTR (B1) HO2S2 MNTR (B2)	- Engine: After warming up - Keeping the engine speed between 3,500 and 4,000 rpm for 1 minute and at idle for 1 minute under no load		LEAN ↔ RICH
VHCL SPEED SE	● Turn drive wheels and compare CONSULT-II value with the speedometer indication.		Almost the same speed as the speedometer indication
BATTERY VOLT	● Ignition switch: ON (Engine stopped)		11 - 14V
ACCEL SEN 1 ACCEL SEN 2*	● Ignition switch: ON (Engine stopped)	Accelerator pedal: Fully released	0.5 - 1.0V
		Accelerator pedal: Fully depressed	4.2 - 4.8V
THRTL SEN 1 THRTL SEN 2*	● Ignition switch: ON (Engine stopped) ● Shift lever: D	Accelerator pedal: Fully released	More than 0.36V
		Accelerator pedal: Fully depressed	Less than 4.75V
EGR TEMP SEN	● Engine: After warming up		Less than 4.5V
EVAP SYS PRES	● Ignition switch: ON		Approx. 1.8 - 4.8V
START SIGNAL	● Ignition switch: ON → START → ON		OFF → ON → OFF
CLSD THL POS	● Ignition switch: ON (Engine stopped)	Accelerator pedal: Fully released	ON
		Accelerator pedal: Slightly depressed	OFF
AIR COND SIG	● Engine: After warming up, idle the engine	Air conditioner switch: OFF	OFF
		Air conditioner switch: ON (Compressor operates.)	ON
P/N POSI SW	● Ignition switch: ON	Shift lever: P or N	ON
		Shift lever: Except above	OFF
PW/ST SIGNAL	● Engine: After warming up, idle the engine	Steering wheel: Not being turned	OFF
		Steering wheel: Being turned	ON
LOAD SIGNAL	● Ignition switch: ON	Rear window defogger switch is ON and/or lighting switch is in 2nd.	ON
		Rear window defogger switch is OFF and lighting switch is OFF.	OFF
IGNITION SW	● Ignition switch: ON → OFF → ON		ON → OFF → ON
HEATER FAN SW	● Engine: After warming up, idle the engine	Heater fan: Operating	ON
		Heater fan: Not operating	OFF
BRAKE SW	● Ignition switch: ON	Brake pedal: Fully released	OFF
		Brake pedal: Slightly depressed	ON

TROUBLE DIAGNOSIS

MONITOR ITEM	CONDITION	SPECIFICATION
INJ PULSE-B1 INJ PULSE-B2	<ul style="list-style-type: none"> ● Engine: After warming up ● Shift lever: P or N 	Idle 2.0 - 3.0 msec
	<ul style="list-style-type: none"> ● Air conditioner switch: OFF ● No load 	2,000 rpm 1.9 - 2.9 msec
IGN TIMING	<ul style="list-style-type: none"> ● Engine: After warming up ● Shift lever: P or N 	Idle 13° - 18° BTDC
	<ul style="list-style-type: none"> ● Air conditioner switch: OFF ● No load 	2,000 rpm 25° - 45° BTDC
CAL/LD VALUE	<ul style="list-style-type: none"> ● Engine: After warming up ● Shift lever: P or N 	Idle 5% - 35%
	<ul style="list-style-type: none"> ● Air conditioner switch: OFF ● No load 	2,500 rpm 5% - 35%
MASS AIRFLOW	<ul style="list-style-type: none"> ● Engine: After warming up ● Shift lever: P or N 	Idle 2.0 - 6.0 g-m/s
	<ul style="list-style-type: none"> ● Air conditioner switch: OFF ● No load 	2,500 rpm 7.0 - 20.0 g-m/s
PURG VOL C/V	<ul style="list-style-type: none"> ● Engine: After warming up ● Shift lever: P or N 	Idle (Accelerator pedal is not depressed even slightly, after engine starting) 0%
	<ul style="list-style-type: none"> ● Air conditioner switch: OFF ● No load 	2,000 rpm —
EGR VOL CON/V	<ul style="list-style-type: none"> ● Engine: After warming up ● Shift lever: P or N 	Idle 0 step
	<ul style="list-style-type: none"> ● Air conditioner switch: OFF ● No load 	Revvng engine from idle up to 3,000 rpm quickly 10 - 55 step
INT/V TIM (B1) INT/V TIM (B2)	<ul style="list-style-type: none"> ● Engine: After warming up ● Shift lever: P or N 	Idle -5° - 5°CA
	<ul style="list-style-type: none"> ● Air conditioner switch: OFF ● No load 	2,000 rpm Approx. 0° - 30°CA
INT/V SOL (B1) INT/V SOL (B2)	<ul style="list-style-type: none"> ● Engine: After warming up ● Shift lever: P or N 	Idle 0% - 2%
	<ul style="list-style-type: none"> ● Air conditioner switch: OFF ● No load 	2,000 rpm Approx. 0% - 50%
VIAS S/V	<ul style="list-style-type: none"> ● Engine: After warming up 	1,800 - 3,600 rpm ON
		Except above conditions OFF
AIR COND RLY	<ul style="list-style-type: none"> ● Engine: After warming up idle the engine 	Air conditioner switch: OFF OFF
		Air conditioner switch: ON (Compressor operates) ON
ENGINE MOUNT	<ul style="list-style-type: none"> ● Engine: Running 	Engine speed: Below 950 rpm IDLE
		Engine speed: Above 950 rpm TRVL
FUEL PUMP RLY	<ul style="list-style-type: none"> ● For 1 second after turning ignition switch ON ● Engine running or cranking 	ON
	<ul style="list-style-type: none"> ● Except above conditions 	OFF
VENT CONT/V	<ul style="list-style-type: none"> ● Ignition switch: ON 	OFF
THRTL RELAY	<ul style="list-style-type: none"> ● Ignition switch: ON 	ON

A
EC

C

D

E

F

G

H

I

J

K

L

M

TROUBLE DIAGNOSIS

MONITOR ITEM	CONDITION	SPECIFICATION
COOLING FAN	● Engine: After warming up, idle the engine ● Air conditioner switch: OFF	Engine coolant temperature: 94°C (201°F) or less OFF
		Engine coolant temperature: Between 95°C (203°F) and 99°C (210°F) LOW
		Engine coolant temperature: Between 100°C (212°F) and 104°C (219°F) MID
		Engine coolant temperature: 105°C (221°F) or more HI
HO2S2 HTR (B1) HO2S2 HTR (B2)	● Engine speed: Below 3,600 rpm after the following conditions are met. – Engine: After warming up – Keeping the engine speed between 3,500 and 4,000 rpm for 1 minute and at idle for 1 minute under no load	ON
	● Engine speed: Above 3,600 rpm	OFF
I/P PULLY SPD	● Vehicle speed: More than 20 km/h (12 MPH)	Almost the same speed as the tachometer indication
VEHICLE SPEED	● Turn drive wheels and compare CONSULT-II value with the speedometer indication.	Almost the same speed as the speedometer indication
TRVL AFTER MIL	● Ignition switch: ON	Vehicle has traveled after MIL has turned ON. 0 - 65,535 km (0 - 40,723 mile)
A/F S1 HTR (B1) A/F S1 HTR (B2)	● Engine: After warming up, idle the engine	0 - 100%
AC PRESS SEN	● Engine: Idle ● Both A/C switch and blower fan switch: ON (Compressor operates)	1.0 - 4.0V
VHCL SPEED SE	● Turn drive wheels and compare speedometer indication with the CONSULT-II value.	Almost the same speed as the speedometer indication
SET VHCL SPD	● Engine: Running	ASCD: Operating. The preset vehicle speed is displayed.
MAIN SW	● Ignition switch: ON	MAIN switch: Pressed ON
		MAIN switch: Released OFF
CANCEL SW	● Ignition switch: ON	CANCEL switch: Pressed ON
		CANCEL switch: Released OFF
RESUME/ACC SW	● Ignition switch: ON	RESUME/ACCELERATE switch: Pressed ON
		RESUME/ACCELERATE switch: Released OFF
SET SW	● Ignition switch: ON	SET/COAST switch: Pressed ON
		SET/COAST switch: Released OFF
BRAKE SW1	● Ignition switch: ON	Brake pedal: Fully released ON
		Brake pedal: Slightly depressed OFF
BRAKE SW2	● Ignition switch: ON	Brake pedal: Fully released OFF
		Brake pedal: Slightly depressed ON
CRUISE LAMP	● Ignition switch: ON	MAIN switch: Pressed at the 1st time → at the 2nd time ON → OFF
SET LAMP	● MAIN switch: ON ● When vehicle speed is between 40 km/h (25 MPH) and 144 km/h (89 MPH)	ACSD: Operating ON
		ASCD: Not operating OFF

*: Accelerator pedal position sensor 2 signal and throttle position sensor 2 signal are converted by ECM internally. Thus, they differ from ECM terminals voltage signal.

TROUBLE DIAGNOSIS

UBS00P1W

Major Sensor Reference Graph in Data Monitor Mode

The following are the major sensor reference graphs in "DATA MONITOR" mode.

CLSD THL POS, ACCEL SEN 1, THRTL SEN 1

Below is the data for "CLSD THL POS", "ACCEL SEN 1" and "THRTL SEN 1" when depressing the accelerator pedal with the ignition switch ON and with shift lever in D position.

The signal of "ACCEL SEN 1" and "THRTL SEN 1" should rise gradually without any intermittent drop or rise after "CLSD THL POS" is changed from ON to OFF.

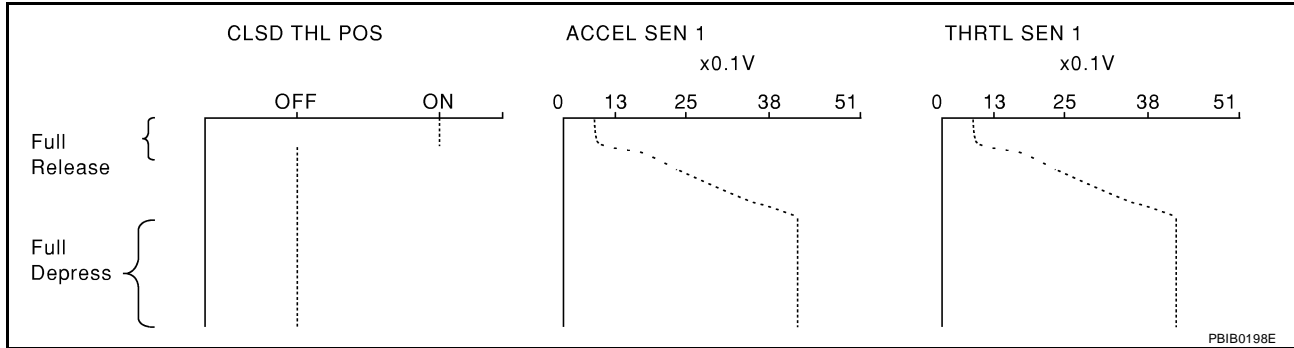

ENG SPEED, MAS A/F SE-B1, THRTL SEN 1, HO2S2 (B1), INJ PULSE-B1

Below is the data for "ENG SPEED", "MAS A/F SE-B1", "THRTL SEN 1", "HO2S2 (B1)" and "INJ PULSE-B1" when revving engine quickly up to 4,800 rpm under no load after warming up engine sufficiently.

Each value is for reference, the exact value may vary.

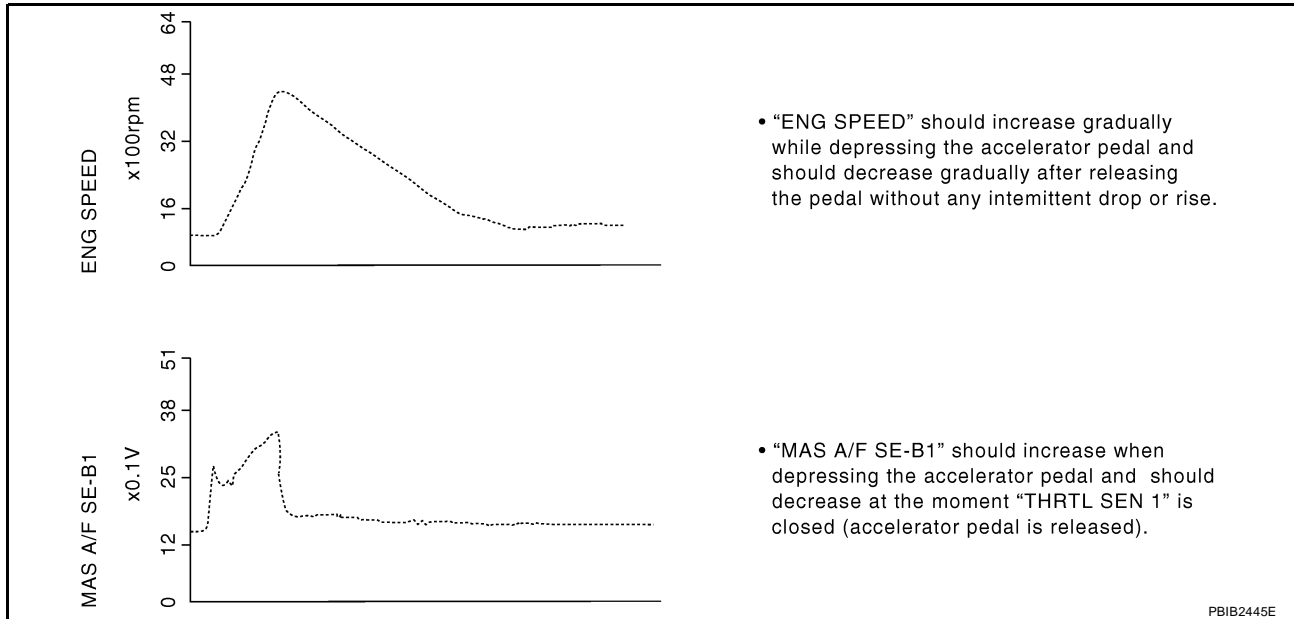

TROUBLE DIAGNOSIS

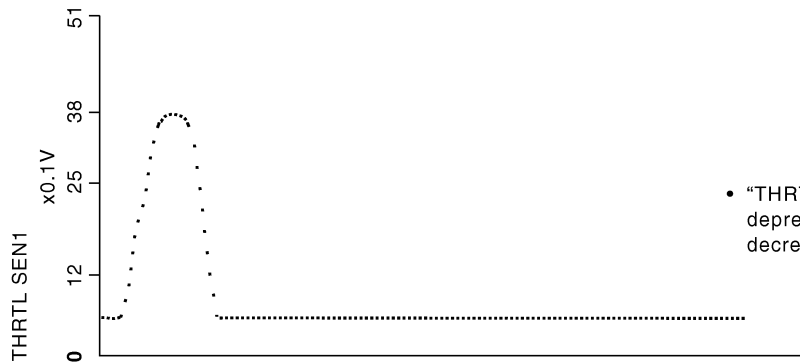

- "THRTL SEN1" should increase while depressing the accelerator pedal and should decrease while releasing it.

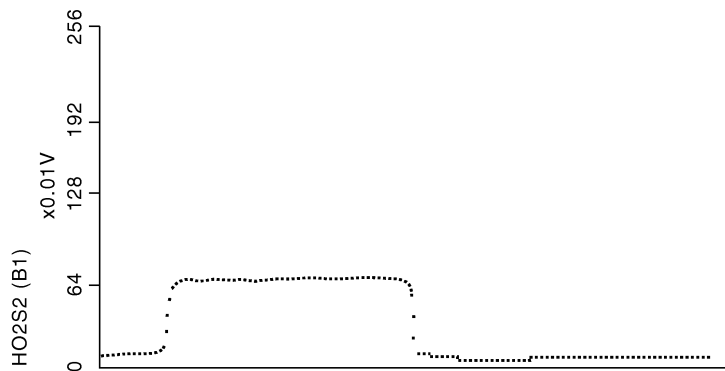

- "HO2S2 (B1)" may increase immediately after depressing the accelerator pedal and may decrease after releasing the pedal.

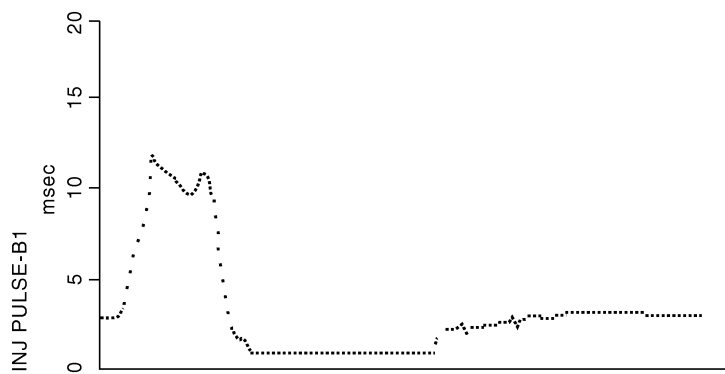

- "INJ PULSE-B1" should increase when depressing the accelerator pedal and should decrease when the pedal is released.

PBIB2099E

TROUBLE DIAGNOSIS - SPECIFICATION VALUE

TROUBLE DIAGNOSIS - SPECIFICATION VALUE

PF0:00031

Description

UBS00P1X

The specification (SP) value indicates the tolerance of the value that is displayed in "DATA MONITOR (SPEC)" mode of CONSULT-II during normal operation of the Engine Control System. When the value in "DATA MONITOR (SPEC)" mode is within the SP value, the Engine Control System is confirmed OK. When the value in "DATA MONITOR (SPEC)" mode is NOT within the SP value, the Engine Control System may have one or more malfunctions.

The SP value is used to detect malfunctions that may affect the Engine Control System, but will not light the MIL.

The SP value will be displayed for the following three items:

- B/FUEL SCHDL (The fuel injection pulse width programmed into ECM prior to any learned on board correction)
- A/F ALPHA-B1/B2 (The mean value of air-fuel ratio feedback correction factor per cycle)
- MAS A/F SE-B1 (The signal voltage of the mass air flow sensor)

Testing Condition

UBS00P1Y

- Vehicle driven distance: More than 5,000 km (3,107 miles)
- Barometric pressure: 98.3 - 104.3 kPa (1.003 - 1.064 kg/cm² , 14.25 - 15.12 psi)
- Atmospheric temperature: 20 - 30°C (68 - 86°F)
- Engine coolant temperature: 75 - 95°C (167 - 203°F)
- Transmission: Warmed-up
 - After the engine is warmed up to normal operating temperature, drive vehicle until "FLUID TEMP SE" (A/T fluid temperature sensor signal) indicates more than 60°C (140°F).
- Electrical load: Not applied
 - Rear window defogger switch, air conditioner switch, lighting switch are OFF. Steering wheel is straight ahead.
- Engine speed: Idle

Inspection Procedure

UBS00P1Z

NOTE:

Perform "DATA MONITOR (SPEC)" mode in maximum scale display.

1. Perform [EC-73, "Basic Inspection"](#) .
2. Confirm that the testing conditions indicated above are met.
3. Select "B/FUEL SCHDL", "A/F ALPHA-B1", "A/F ALPHA-B2" and "MAS A/F SE-B1" in "DATA MONITOR (SPEC)" mode with CONSULT-II.
4. Make sure that monitor items are within the SP value.
5. If NG, go to [EC-140, "Diagnostic Procedure"](#) .

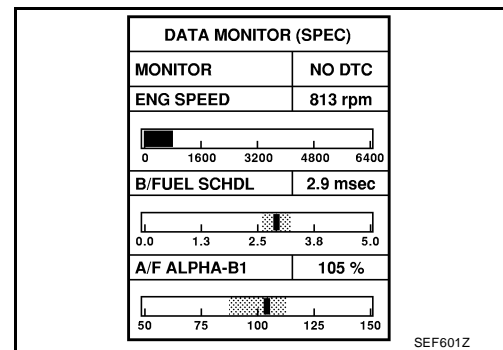

TROUBLE DIAGNOSIS - SPECIFICATION VALUE

UBS00P20

Diagnostic Procedure OVERALL SEQUENCE

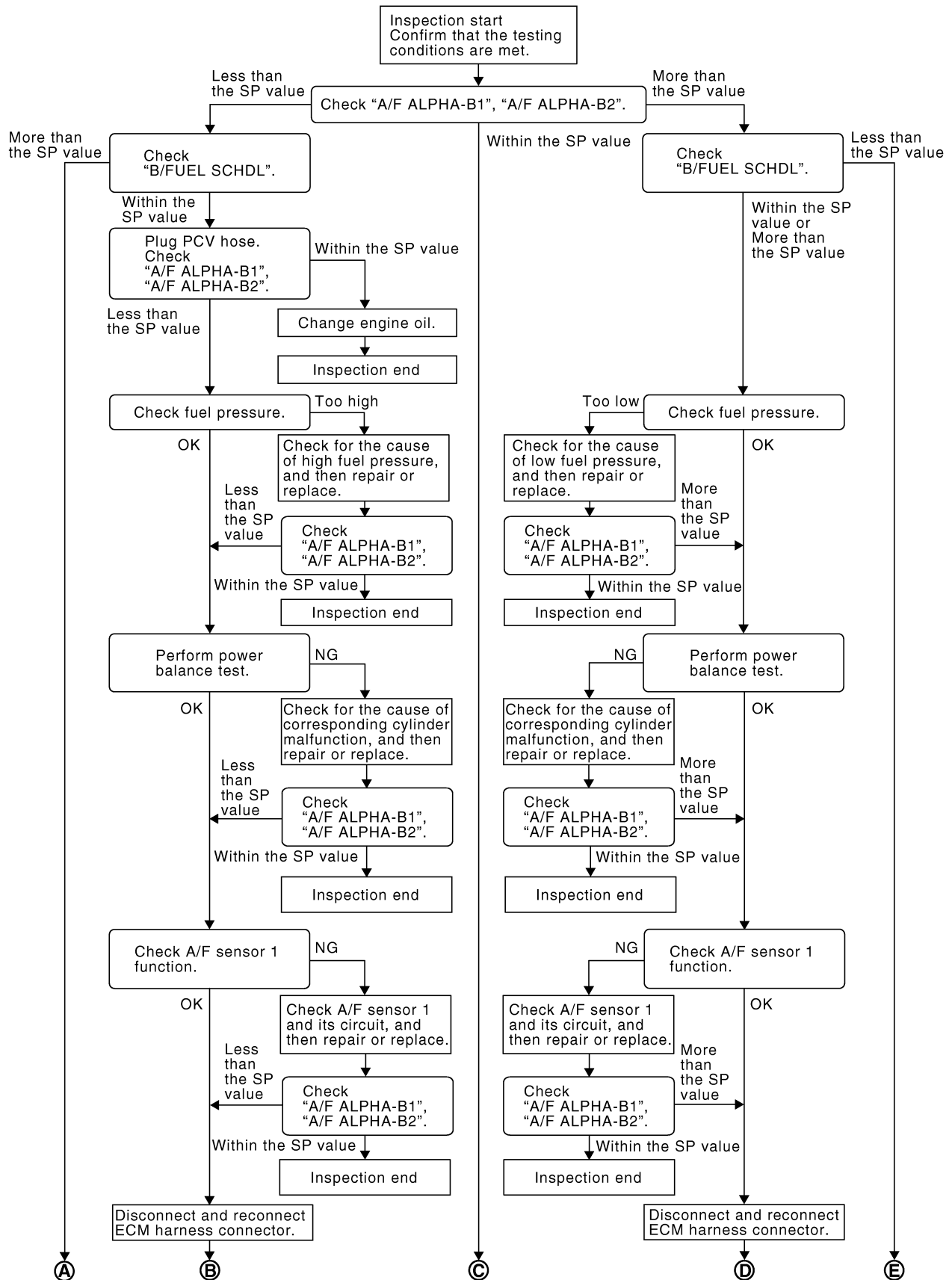

PBIB2268E

TROUBLE DIAGNOSIS - SPECIFICATION VALUE

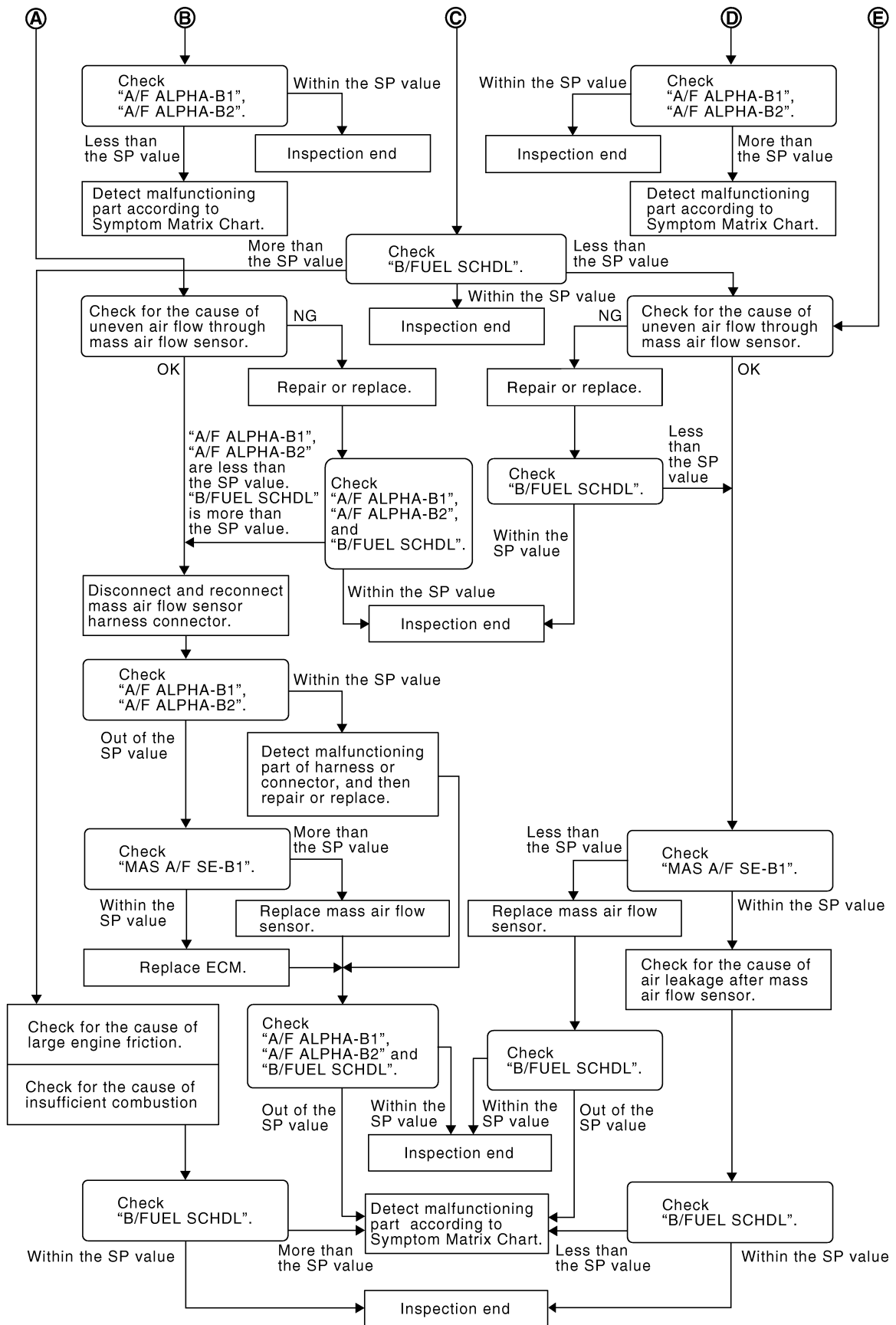

A
 EC
 C
 D
 E
 F
 G
 H
 I
 J
 K
 L
 M

PBIB3214E

TROUBLE DIAGNOSIS - SPECIFICATION VALUE

DETAILED PROCEDURE

1. CHECK "A/F ALPHA-B1", "A/F ALPHA-B2"

1. Start engine.
2. Confirm that the testing conditions are met. Refer to [EC-139, "Testing Condition"](#).
3. Select "A/F ALPHA-B1", "A/F ALPHA-B2" in "DATA MONITOR (SPEC)" mode, and make sure that the each indication is within the SP value.

NOTE:

Check "A/F ALPHA-B1", "A/F ALPHA-B2" for approximately 1 minute because they may fluctuate. It is NG if the indication is out of the SP value even a little.

OK or NG

- OK >> GO TO 17.
NG (Less than the SP value)>>GO TO 2.
NG (More than the SP value)>>GO TO 3.

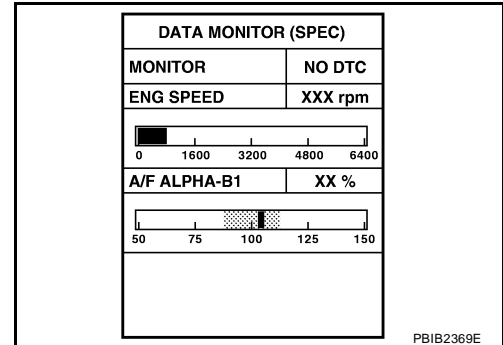

2. CHECK "B/FUEL SCHDL"

Select "B/FUEL SCHDL" in "DATA MONITOR (SPEC)" mode, and make sure that the indication is within the SP value.

OK or NG

- OK >> GO TO 4.
NG (More than the SP value)>>GO TO 19.

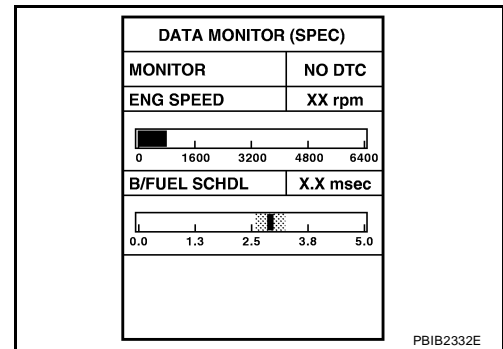

3. CHECK "B/FUEL SCHDL"

Select "B/FUEL SCHDL" in "DATA MONITOR (SPEC)" mode, and make sure that the indication is within the SP value.

OK or NG

- OK >> GO TO 6.
NG (More than the SP value)>>GO TO 6.
NG (Less than the SP value)>>GO TO 25.

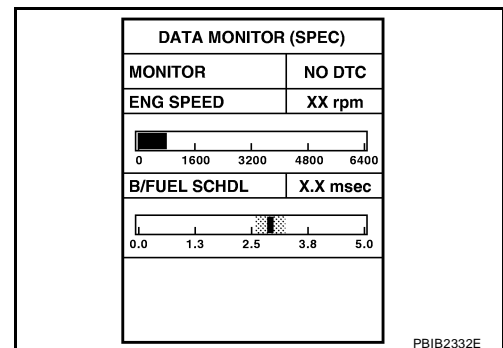

4. CHECK "A/F ALPHA-B1", "A/F ALPHA-B2"

1. Stop the engine.
2. Disconnect PCV hose, and then plug it.
3. Start engine.
4. Select "A/F ALPHA-B1", "A/F ALPHA-B2" in "DATA MONITOR (SPEC)" mode, and make sure that the each indication is within the SP value.

OK or NG

- OK >> GO TO 5.
NG >> GO TO 6.

TROUBLE DIAGNOSIS - SPECIFICATION VALUE

5. CHANGE ENGINE OIL

1. Stop the engine.
2. Change engine oil.

NOTE:

This symptom may occur when a large amount of gasoline is mixed with engine oil because of driving conditions (such as when engine oil temperature does not rise enough since a journey distance is too short during winter). The symptom will not be detected after changing engine oil or changing driving condition.

>> **INSPECTION END**

6. CHECK FUEL PRESSURE

Check fuel pressure. (Refer to [EC-82, "Fuel Pressure Check"](#) .)

OK or NG

OK >> GO TO 9.

NG (Fuel pressure is too high)>>Replace fuel pressure regulator, refer to [EC-83, "FUEL PRESSURE CHECK"](#) . GO TO 8.

NG (Fuel pressure is too low)>>GO TO 7.

7. DETECT MALFUNCTIONING PART

1. Check the following.
 - Clogged and bent fuel hose and fuel tube
 - Clogged fuel filter
 - Fuel pump and its circuit (Refer to [EC-685, "FUEL PUMP"](#) .)
2. If NG, repair or replace the malfunctioning part. (Refer to [EC-82, "Fuel Pressure Check"](#) .)
If OK, replace fuel pressure regulator.

>> GO TO 8.

8. CHECK "A/F ALPHA-B1", "A/F ALPHA-B2"

1. Start engine.
2. Select "A/F ALPHA-B1", "A/F ALPHA-B2" in "DATA MONITOR (SPEC)" mode, and make sure that the each indication is within the SP value.

OK or NG

OK >> **INSPECTION END**

NG >> GO TO 9.

9. PERFORM POWER BALANCE TEST

1. Perform "POWER BALANCE" in "ACTIVE TEST" mode.
2. Make sure that the each cylinder produces a momentary engine speed drop.

OK or NG

OK >> GO TO 12.

NG >> GO TO 10.

ACTIVE TEST	
POWER BALANCE	
MONITOR	
ENG SPEED	XXX rpm
MAS A/F SE-B1	XXX V

PBIB0133E

TROUBLE DIAGNOSIS - SPECIFICATION VALUE

10. DETECT MALFUNCTIONING PART

1. Check the following.
 - Ignition coil and its circuit (Refer to [EC-691, "IGNITION SIGNAL"](#) .)
 - Fuel injector and its circuit (Refer to [EC-678, "FUEL INJECTOR"](#) .)
 - Intake air leakage
 - Low compression pressure (Refer to [EM-96, "CHECKING COMPRESSION PRESSURE"](#) .)
2. If NG, repair or replace the malfunctioning part.
If OK, replace fuel injector. (It may be caused by leakage from fuel injector or clogging.)

>> GO TO 11.

11. CHECK "A/F ALPHA-B1", "A/F ALPHA-B2"

1. Start engine.
2. Select "A/F ALPHA-B1", "A/F ALPHA-B2" in "DATA MONITOR (SPEC)" mode, and make sure that the each indication is within the SP value.

OK or NG

OK >> **INSPECTION END**
NG >> GO TO 12.

12. CHECK A/F SENSOR 1 FUNCTION

Perform all DTC Confirmation Procedure related with A/F sensor 1.

- For DTC P0130, P0150, refer to [EC-239, "DTC Confirmation Procedure"](#) .
- For DTC P0131, P0151, refer to [EC-250, "DTC Confirmation Procedure"](#) .
- For DTC P0132, P0152, refer to [EC-260, "DTC Confirmation Procedure"](#) .
- For DTC P0133, P0153, refer to [EC-271, "DTC Confirmation Procedure"](#) .
- For DTC P2A00, P2A03, refer to [EC-649, "DTC Confirmation Procedure"](#) .

OK or NG

OK >> GO TO 15.
NG >> GO TO 13.

13. CHECK A/F SENSOR 1 CIRCUIT

Perform Diagnostic Procedure according to corresponding DTC.

>> GO TO 14.

14. CHECK "A/F ALPHA-B1", "A/F ALPHA-B2"

1. Start engine.
2. Select "A/F ALPHA-B1", "A/F ALPHA-B2" in "DATA MONITOR (SPEC)" mode, and make sure that the each indication is within the SP value.

OK or NG

OK >> **INSPECTION END**
NG >> GO TO 15.

15. DISCONNECT AND RECONNECT ECM HARNESS CONNECTOR

1. Stop the engine.
2. Disconnect ECM harness connector. Check pin terminal and connector for damage, and then reconnect it.

>> GO TO 16.

TROUBLE DIAGNOSIS - SPECIFICATION VALUE

16. CHECK "A/F ALPHA-B1", "A/F ALPHA-B2"

1. Start engine.
2. Select "A/F ALPHA-B1", "A/F ALPHA-B2" in "DATA MONITOR (SPEC)" mode, and make sure that the each indication is within the SP value.

OK or NG

OK >> **INSPECTION END**

NG >> Detect malfunctioning part according to [EC-95, "Symptom Matrix Chart"](#) .

17. CHECK "B/FUEL SCHDL"

Select "B/FUEL SCHDL" in "DATA MONITOR (SPEC)" mode, and make sure that the indication is within the SP value.

OK or NG

OK >> **INSPECTION END**

NG (More than the SP value)>>GO TO 18.

NG (Less than the SP value)>>GO TO 25.

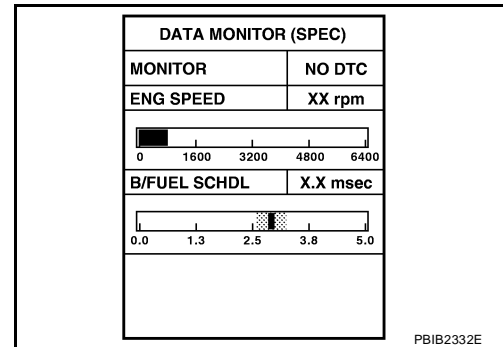

18. DETECT MALFUNCTIONING PART

1. Check for the cause of large engine friction. Refer to the following.
 - Engine oil level is too high
 - Engine oil viscosity
 - Belt tension of power steering, alternator, A/C compressor, etc. is excessive
 - Noise from engine
 - Noise from transmission, etc.
2. Check for the cause of insufficient combustion. Refer to the following.
 - EGR valve stuck
 - Valve clearance malfunction
 - Intake valve timing control function malfunction
 - Camshaft sprocket installation malfunction, etc.

>> Repair or replace malfunctioning part, and then GO TO 30.

19. CHECK INTAKE SYSTEM

Check for the cause of uneven air flow through mass air flow sensor. Refer to the following.

- Crushed air ducts
- Malfunctioning seal of air cleaner element
- Uneven dirt of air cleaner element
- Improper specification of intake air system

OK or NG

OK >> GO TO 21.

NG >> Repair or replace malfunctioning part, and then GO TO 20.

TROUBLE DIAGNOSIS - SPECIFICATION VALUE

20. CHECK "A/F ALPHA-B1", "A/F ALPHA-B2", AND "B/FUEL SCHDL"

Select "A/F ALPHA-B1", "A/F ALPHA-B2", and "B/FUEL SCHDL" in "DATA MONITOR (SPEC)" mode, and make sure that the each indication is within the SP value.

OK or NG

OK >> **INSPECTION END**

NG ("B/FUEL SCHDL" is more, "A/F ALPHA-B1", "A/F ALPHA-B2" are less than the SP value)>>GO TO 21.

21. DISCONNECT AND RECONNECT MASS AIR FLOW SENSOR HARNESS CONNECTOR

1. Stop the engine.
2. Disconnect mass air flow sensor harness connector. Check pin terminal and connector for damage and then reconnect it again.

>> GO TO 22.

22. CHECK "A/F ALPHA-B1", "A/F ALPHA-B2"

1. Start engine.
2. Select "A/F ALPHA-B1", "A/F ALPHA-B2" in "DATA MONITOR (SPEC)" mode, and make sure that the each indication is within the SP value.

OK or NG

OK >> 1. Detect malfunctioning part of mass air flow sensor circuit and repair it. Refer to [EC-202, "DTC P0102, P0103 MAF SENSOR"](#) .

2. GO TO 29.

NG >> GO TO 23.

23. CHECK "MAS A/F SE-B1"

Select "MAS A/F SE-B1" in "DATA MONITOR (SPEC)" mode, and make sure that the indication is within the SP value.

OK or NG

OK >> GO TO 24.

NG (More than the SP value)>>Replace mass air flow sensor, and then GO TO 29.

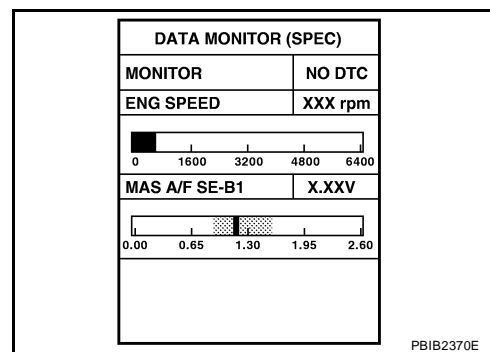

24. REPLACE ECM

1. Replace ECM.
2. Perform initialization of NVIS(NATS) system and registration of all NVIS(NATS) ignition key IDs. Refer to [BL-203, "NVIS\(NISSAN Vehicle Immobilizer System-NATS\)"](#) .
3. Perform [EC-79, "VIN Registration"](#) .
4. Perform [EC-80, "Accelerator Pedal Released Position Learning"](#) .
5. Perform [EC-80, "Throttle Valve Closed Position Learning"](#) .
6. Perform [EC-80, "Idle Air Volume Learning"](#) .

>> GO TO 29.

TROUBLE DIAGNOSIS - SPECIFICATION VALUE

25. CHECK INTAKE SYSTEM

Check for the cause of uneven air flow through mass air flow sensor. Refer to the following.

- Crushed air ducts
- Malfunctioning seal of air cleaner element
- Uneven dirt of air cleaner element
- Improper specification of intake air system

OK or NG

OK >> GO TO 27.

NG >> Repair or replace malfunctioning part, and then GO TO 26.

26. CHECK "B/FUEL SCHDL"

Select "B/FUEL SCHDL" in "DATA MONITOR (SPEC)" mode, and make sure that the indication is within the SP value.

OK or NG

OK >> **INSPECTION END**

NG (Less than the SP value)>>GO TO 27.

27. CHECK "MAS A/F SE-B1"

Select "MAS A/F SE-B1" in "DATA MONITOR (SPEC)" mode, and make sure that the indication is within the SP value.

OK or NG

OK >> GO TO 28.

NG (Less than the SP value)>>Replace mass air flow sensor, and then GO TO 30.

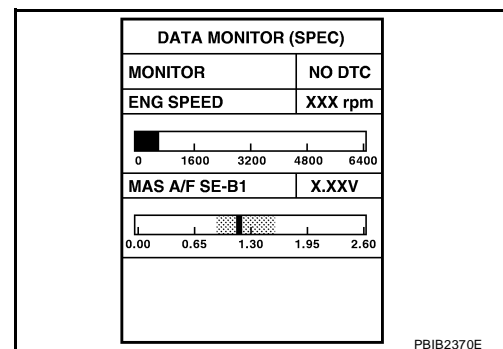

28. CHECK INTAKE SYSTEM

Check for the cause of air leak after the mass air flow sensor. Refer to the following.

- Disconnection, looseness, and cracks in air duct
- Looseness of oil filler cap
- Disconnection of oil level gauge
- Open stuck, breakage, hose disconnection, or cracks of PCV valve
- Disconnection or cracks of EVAP purge hose, open stuck of EVAP canister purge volume control solenoid valve
- Malfunctioning seal of rocker cover gasket
- Disconnection, looseness, or cracks of hoses, such as vacuum hose, connecting to intake air system parts
- Malfunctioning seal of intake air system, etc.

>> GO TO 30.

29. CHECK "A/F ALPHA-B1", "A/F ALPHA-B2", AND "B/FUEL SCHDL"

Select "A/F ALPHA-B1", "A/F ALPHA-B2", and "B/FUEL SCHDL" in "DATA MONITOR (SPEC)" mode, and make sure that the each indication is within the SP value.

OK or NG

OK >> **INSPECTION END**

NG >> Detect malfunctioning part according to [EC-95, "Symptom Matrix Chart"](#).

TROUBLE DIAGNOSIS - SPECIFICATION VALUE

30. CHECK "B/FUEL SCHDL"

Select "B/FUEL SCHDL" in "DATA MONITOR (SPEC)" mode, and then make sure that the indication is within the SP value.

OK or NG

OK >> **INSPECTION END**

NG >> Detect malfunctioning part according to [EC-95, "Symptom Matrix Chart"](#) .

TROUBLE DIAGNOSIS FOR INTERMITTENT INCIDENT

TROUBLE DIAGNOSIS FOR INTERMITTENT INCIDENT

PF0:00006

Description

UBS00P21

Intermittent incidents may occur. In many cases, the malfunction resolves itself (the part or circuit function returns to normal without intervention). It is important to realize that the symptoms described in the customer's complaint often do not recur on (1st trip) DTC visits. Realize also that the most frequent cause of intermittent incidents occurrences is poor electrical connections. Because of this, the conditions under which the incident occurred may not be clear. Therefore, circuit checks made as part of the standard diagnostic procedure may not indicate the specific malfunctioning area.

Common Intermittent Incidents Report Situations

STEP in Work Flow	Situation
2	The CONSULT-II is used. The SELF-DIAG RESULTS screen shows time data other than [0] or [1t].
3 or 4	The symptom described by the customer does not recur.
5	(1st trip) DTC does not appear during the DTC Confirmation Procedure.
10	The Diagnostic Procedure for PXXXX does not indicate the malfunctioning area.

Diagnostic Procedure

UBS00P22

1. INSPECTION START

Erase (1st trip) DTCs. Refer to [EC-63, "HOW TO ERASE EMISSION-RELATED DIAGNOSTIC INFORMATION"](#).

>> GO TO 2.

2. CHECK GROUND TERMINALS

Check ground terminals for corroding or loose connection.
Refer to [EC-158, "Ground Inspection"](#)

OK or NG

OK >> GO TO 3.

NG >> Repair or replace.

3. SEARCH FOR ELECTRICAL INCIDENT

Perform [GI-26, "How to Perform Efficient Diagnosis for an Electrical Incident"](#), "INCIDENT SIMULATION TESTS".

OK or NG

OK >> GO TO 4.

NG >> Repair or replace.

4. CHECK CONNECTOR TERMINALS

Refer to [GI-23, "How to Check Terminal"](#), "HOW TO PROBE CONNECTORS", "How to Check Enlarged Contact Spring of Terminal".

OK or NG

OK >> **INSPECTION END**

NG >> Repair or replace connector.

POWER SUPPLY AND GROUND CIRCUIT

POWER SUPPLY AND GROUND CIRCUIT

PF2:24110

Wiring Diagram

UBS00P23

EC-MAIN-01

: DETECTABLE LINE FOR DTC
 : NON-DETECTABLE LINE FOR DTC

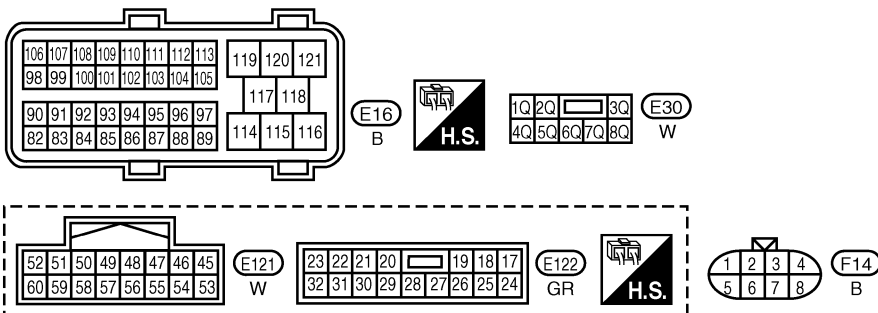
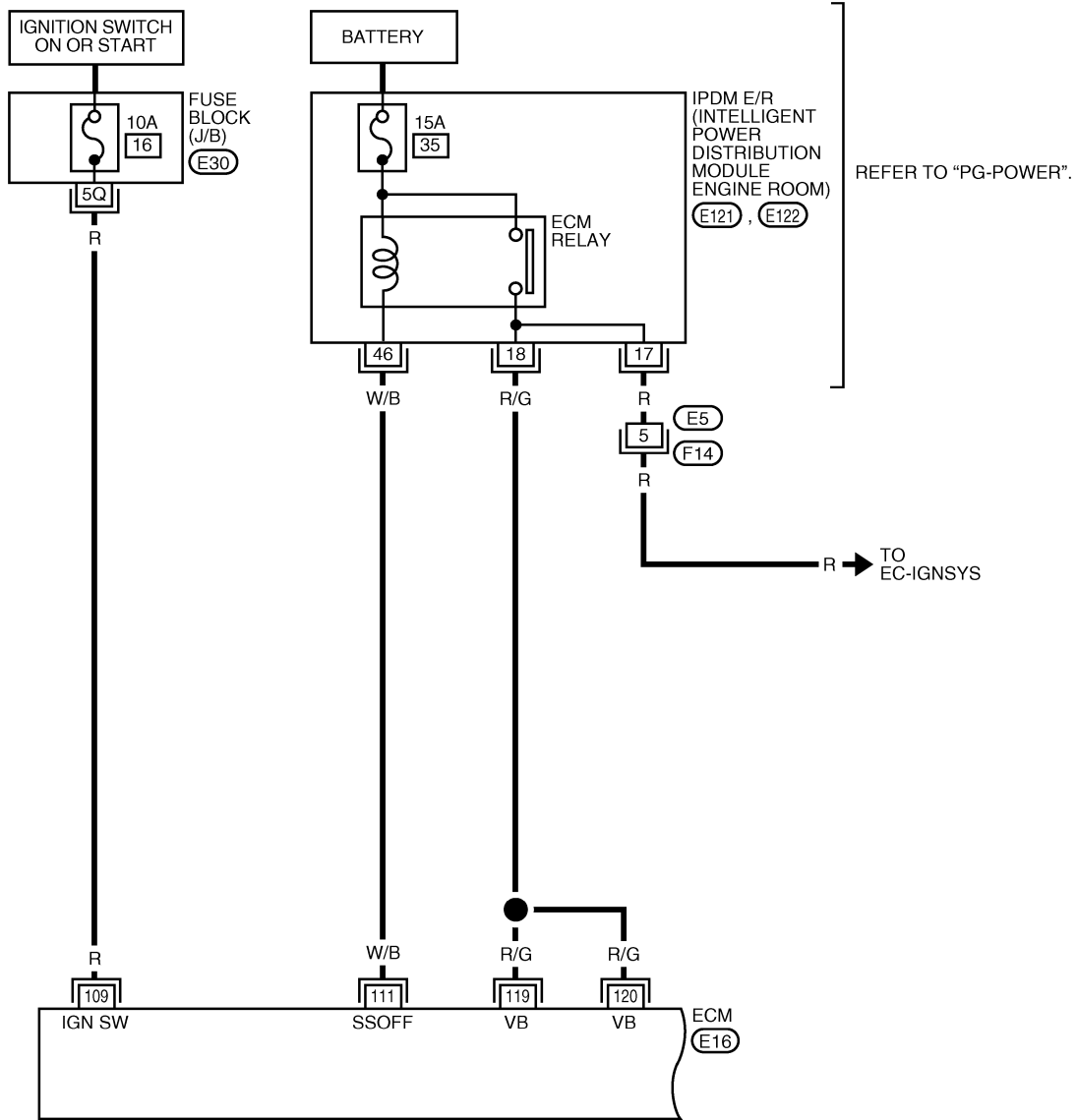

BBWA2500E

POWER SUPPLY AND GROUND CIRCUIT

Specification data are reference values and are measured between each terminal and ground.

CAUTION:

Do not use ECM ground terminals when measuring input/output voltage. Doing so may result in damage to the ECM's transistor. Use a ground other than ECM terminals, such as the ground.

TER-MINAL NO.	WIRE COLOR	ITEM	CONDITION	DATA (DC Voltage)
109	R	Ignition switch	[Ignition switch: OFF]	0V
			[Ignition switch: ON]	BATTERY VOLTAGE (11 - 14V)
111	W/B	ECM relay (Self shut-off)	[Engine is running] [Ignition switch: OFF] ● For a few seconds after turning ignition switch OFF	0 - 1.5V
			[Ignition switch: OFF] ● More than a few seconds after turning ignition switch OFF	BATTERY VOLTAGE (11 - 14V)
119 120	R/G R/G	Power supply for ECM	[Ignition switch: ON]	BATTERY VOLTAGE (11 - 14V)

A
EC
C
D
E
F
G
H
I
J
K
L
M

POWER SUPPLY AND GROUND CIRCUIT

EC-MAIN-02

: DETECTABLE LINE FOR DTC
 : NON-DETECTABLE LINE FOR DTC

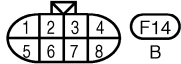
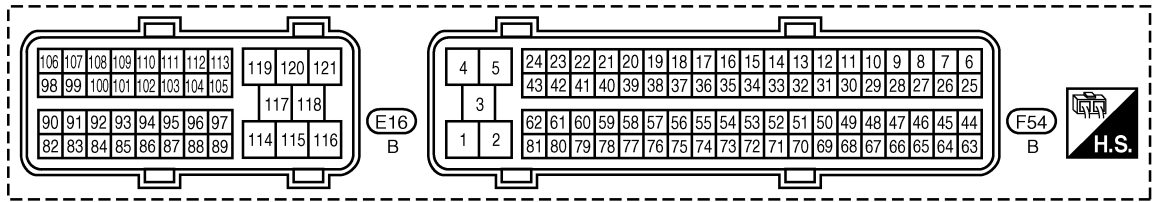
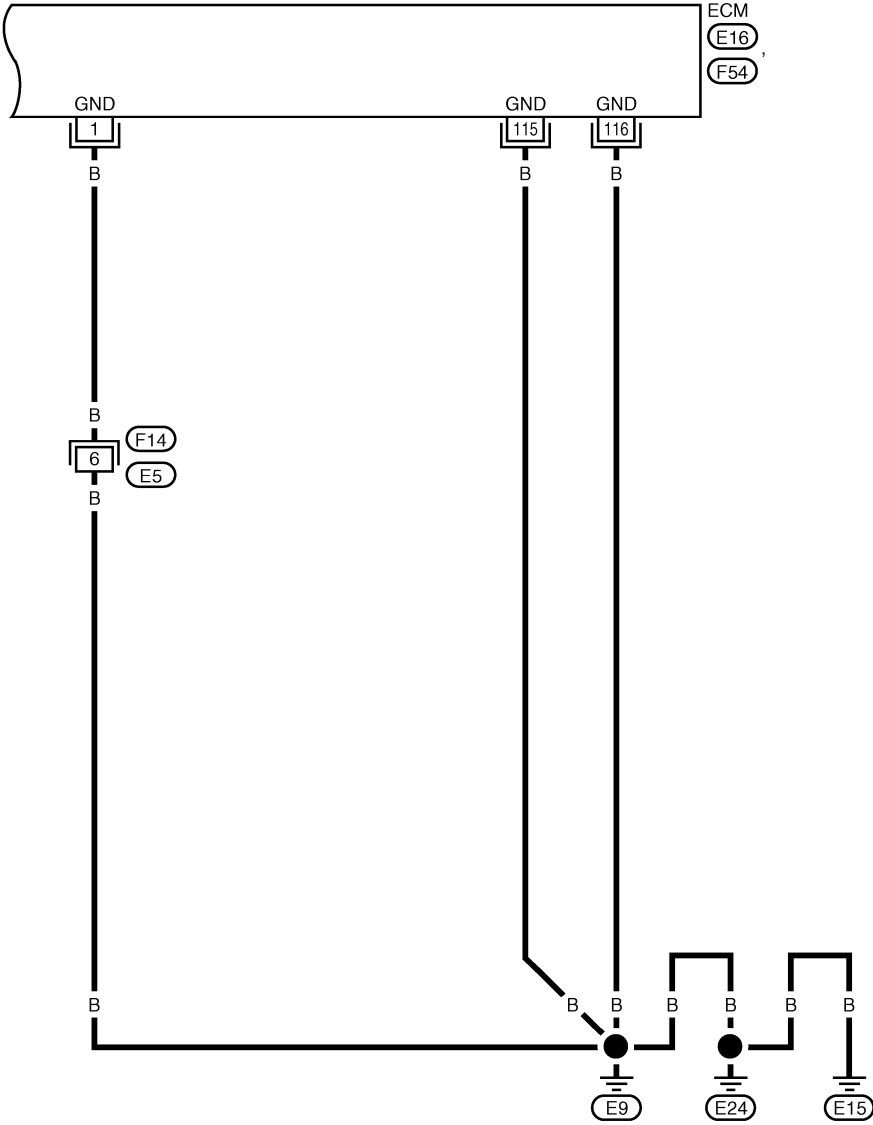

BBWA2501E

POWER SUPPLY AND GROUND CIRCUIT

Specification data are reference values and are measured between each terminal and ground.

CAUTION:

Do not use ECM ground terminals when measuring input/output voltage. Doing so may result in damage to the ECM's transistor. Use a ground other than ECM terminals, such as the ground.

TER-MINAL NO.	WIRE COLOR	ITEM	CONDITION	DATA (DC Voltage)
1	B	ECM ground	[Engine is running] ● Idle speed	Body ground
115 116	B B	ECM ground	[Engine is running] ● Idle speed	Body ground

Diagnostic Procedure

UBS00P24

1. INSPECTION START

Start engine.

Is engine running?

Yes or No

- Yes >> GO TO 8.
- No >> GO TO 2.

2. CHECK ECM POWER SUPPLY CIRCUIT-I

1. Turn ignition switch OFF and then ON.
2. Check voltage between ECM terminal 109 and ground with CONSULT-II or tester.

Voltage: Battery voltage

OK or NG

- OK >> GO TO 4.
- NG >> GO TO 3.

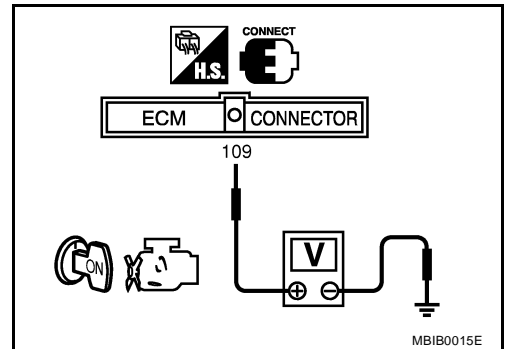

3. DETECT MALFUNCTIONING PART

Check the following.

- Fuse block (J/B) connector E30
- 10A fuse
- Harness for open or short between ECM and fuse

>> Repair harness or connectors.

POWER SUPPLY AND GROUND CIRCUIT

4. CHECK GROUND CONNECTIONS

1. Turn ignition switch OFF.
2. Loosen and retighten three ground screws on the body. Refer to [EC-158, "Ground Inspection"](#) .

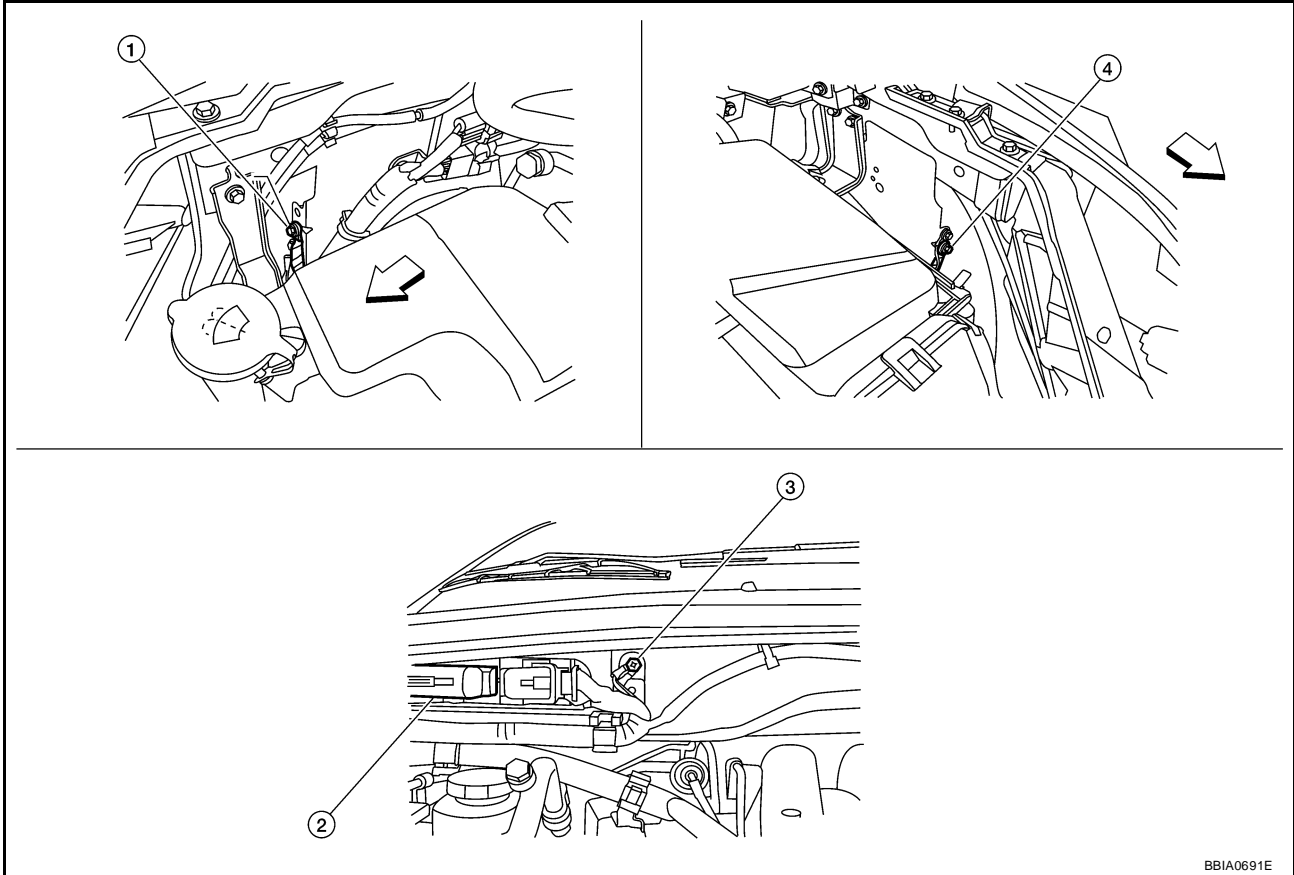

↔ Vehicle front

1. Body ground E24
4. Body ground E15

2. ECM

3. Body ground E9

OK or NG

- OK >> GO TO 5.
NG >> Repair or replace ground connections.

5. CHECK ECM GROUND CIRCUIT FOR OPEN AND SHORT-I

1. Disconnect ECM harness connector.
2. Check harness continuity between ECM terminals 1, 115, 116 and ground.
Refer to Wiring Diagram.

Continuity should exist.

3. Also check harness for short to power.

OK or NG

- OK >> GO TO 7.
NG >> GO TO 6.

POWER SUPPLY AND GROUND CIRCUIT

6. DETECT MALFUNCTIONING PART

Check the following.

- Harness connectors F14, E5
- Harness for open or short between ECM and ground

>> Repair open circuit or short to power in harness or connectors.

7. CHECK ECM POWER SUPPLY CIRCUIT-II

1. Reconnect ECM harness connector.
2. Turn ignition switch ON.
3. Check voltage between IPDM E/R terminal 17 and ground with CONSULT-II or tester.

Voltage: Battery voltage

OK or NG

- OK >> Go to [EC-691, "IGNITION SIGNAL"](#).
- NG >> GO TO 8.

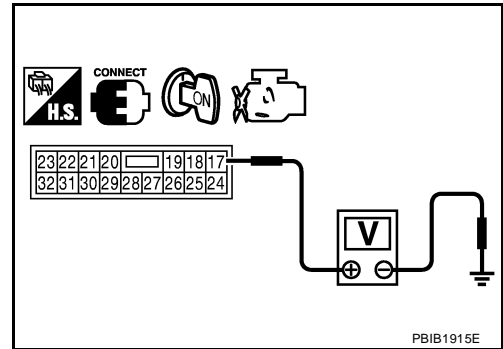

8. CHECK ECM POWER SUPPLY CIRCUIT-III

1. Turn ignition switch OFF and wait at least 10 seconds.
2. Turn ignition switch ON and then OFF.
3. Check voltage between ECM terminals 119, 120 and ground with CONSULT-II or tester.

Voltage: After turning ignition switch OFF, battery voltage will exist for a few seconds, then drop approximately 0V.

OK or NG

- OK >> GO TO 13.
- NG (Battery voltage does not exist.)>>GO TO 9.
- NG (Battery voltage exists for more than a few seconds.)>>GO TO 11.

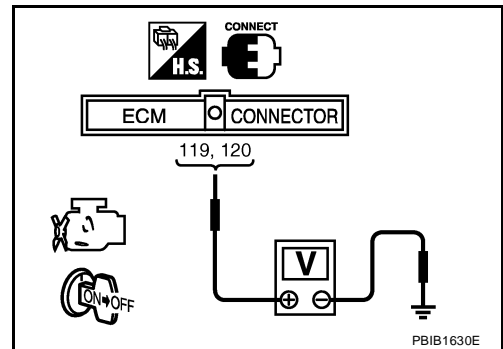

9. CHECK ECM POWER SUPPLY CIRCUIT-IV

Check voltage between ECM terminal 111 and ground with CONSULT-II or tester.

Voltage: Battery voltage

OK or NG

- OK >> GO TO 10.
- NG >> GO TO 11.

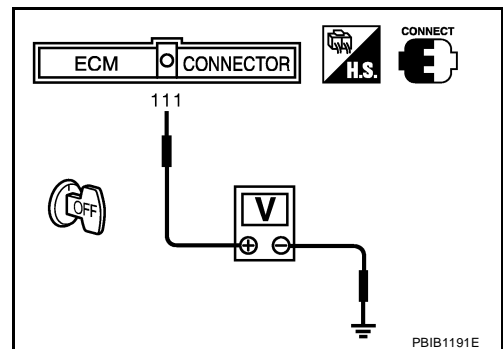

POWER SUPPLY AND GROUND CIRCUIT

10. CHECK ECM POWER SUPPLY CIRCUIT-V

1. Disconnect ECM harness connector.
2. Disconnect IPDM E/R harness connector E122.
3. Check harness continuity between ECM terminals 119, 120 and IPDM E/R terminal 18.
Refer to Wiring Diagram.

Continuity should exist.

4. Also check harness for short to ground and short to power.

OK or NG

OK >> GO TO 16.

NG >> Repair open circuit or short to ground or short to power in harness or connectors.

11. CHECK ECM POWER SUPPLY CIRCUIT-VI

1. Disconnect ECM harness connector.
2. Disconnect IPDM E/R harness connector E121.
3. Check harness continuity between ECM terminal 111 and IPDM E/R terminal 46.
Refer to Wiring Diagram.

Continuity should exist.

4. Also check harness for short to ground and short to power.

OK or NG

OK >> GO TO 12.

NG >> Repair open circuit or short to ground or short to power in harness or connectors.

12. CHECK 15A FUSE

1. Disconnect 15A fuse from IPDM E/R.
2. Check 15A fuse.

OK or NG

OK >> GO TO 16.

NG >> Replace 15A fuse.

POWER SUPPLY AND GROUND CIRCUIT

13. CHECK GROUND CONNECTIONS

1. Loosen and retighten three ground screws on the body. Refer to [EC-158, "Ground Inspection"](#) .

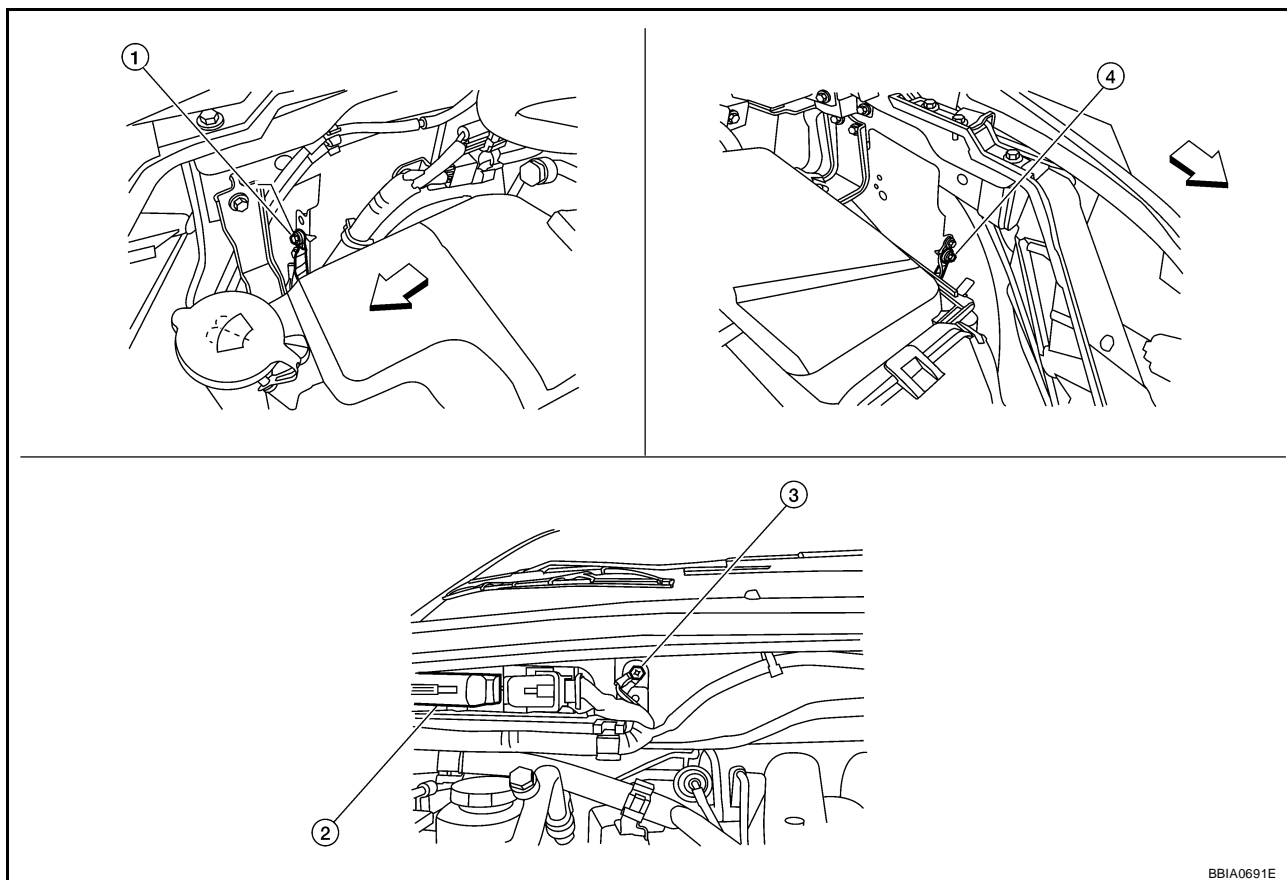

← Vehicle front

1. Body ground E24
4. Body ground E15

2. ECM

3. Body ground E9

OK or NG

OK >> GO TO 14.

NG >> Repair or replace ground connections.

14. CHECK ECM GROUND CIRCUIT FOR OPEN AND SHORT-II

1. Disconnect ECM harness connector.
2. Check harness continuity between ECM terminals 1, 115, 116 and ground. Refer to Wiring Diagram.

Continuity should exist.

3. Also check harness for short to power.

OK or NG

OK >> GO TO 16.

NG >> GO TO 15.

POWER SUPPLY AND GROUND CIRCUIT

15. DETECT MALFUNCTIONING PART

Check the following.

- Harness connectors F14, E5
- Harness for open or short between ECM and ground

>> Repair open circuit or short to power in harness or connectors.

16. CHECK INTERMITTENT INCIDENT

Refer to [EC-149, "TROUBLE DIAGNOSIS FOR INTERMITTENT INCIDENT"](#) .

OK or NG

OK >> Replace IPDM E/R. Refer to [PG-18, "IPDM E/R \(INTELLIGENT POWER DISTRIBUTION MODULE ENGINE ROOM\)"](#) .

NG >> Repair open circuit or short to power in harness or connectors.

Ground Inspection

UBS00P25

Ground connections are very important to the proper operation of electrical and electronic circuits. Ground connections are often exposed to moisture, dirt and other corrosive elements. The corrosion (rust) can become an unwanted resistance. This unwanted resistance can change the way a circuit works.

Electronically controlled circuits are very sensitive to proper grounding. A loose or corroded ground can drastically affect an electronically controlled circuit. A poor or corroded ground can easily affect the circuit. Even when the ground connection looks clean, there can be a thin film of rust on the surface.

When inspecting a ground connection follow these rules:

- Remove the ground bolt or screw.
- Inspect all mating surfaces for tarnish, dirt, rust, etc.
- Clean as required to assure good contact.
- Reinstall bolt or screw securely.
- Inspect for "add-on" accessories which may be interfering with the ground circuit.
- If several wires are crimped into one ground eyelet terminal, check for proper crimps. Make sure all of the wires are clean, securely fastened and providing a good ground path. If multiple wires are cased in one eyelet make sure no ground wires have excess wire insulation.

For detailed ground distribution information, refer to [PG-34, "Ground Distribution"](#) .

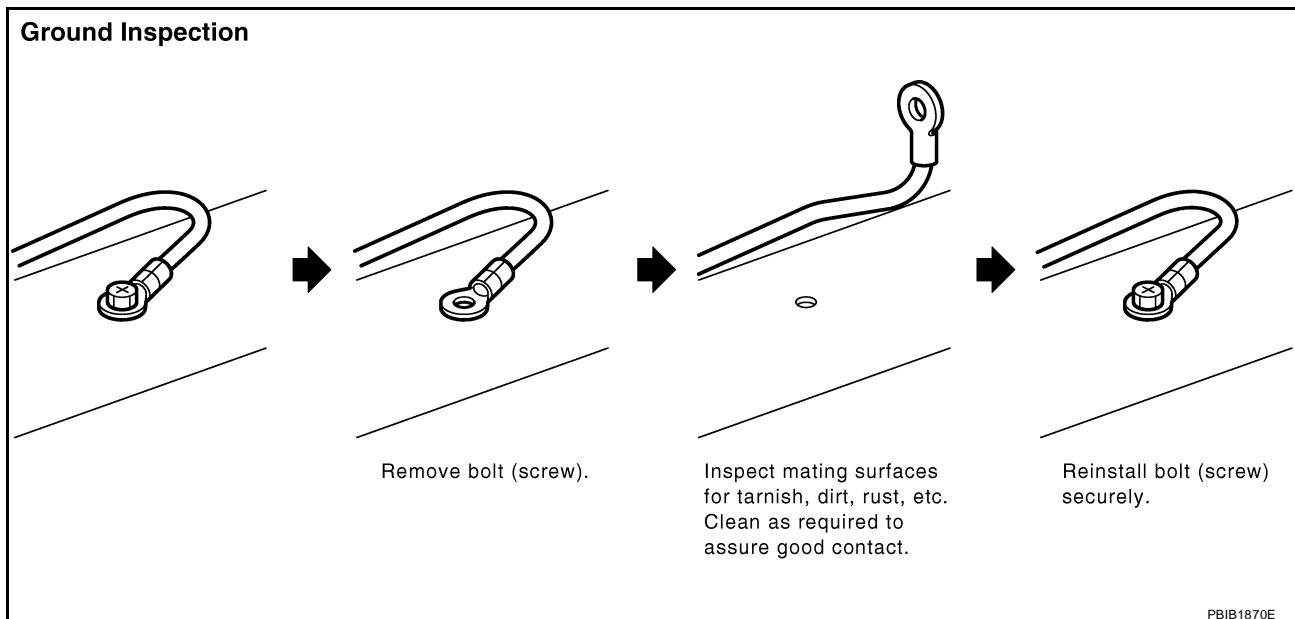

DTC U1000, U1001 CAN COMMUNICATION LINE

DTC U1000, U1001 CAN COMMUNICATION LINE

PDF:23710

Description

UBS00P26

CAN (Controller Area Network) is a serial communication line for real time application. It is an on-vehicle multiplex communication line with high data communication speed and excellent error detection ability. Many electronic control units are equipped onto a vehicle, and each control unit shares information and links with other control units during operation (not independent). In CAN communication, control units are connected with 2 communication lines (CAN H line, CAN L line) allowing a high rate of information transmission with less wiring. Each control unit transmits/receives data but selectively reads required data only.

On Board Diagnosis Logic

UBS00P27

DTC No.	Trouble diagnosis name	DTC detecting condition	Possible cause
U1000*1 1000*1	CAN communication line	<ul style="list-style-type: none">When ECM is not transmitting or receiving CAN communication signal of OBD (emission-related diagnosis) for 2 seconds or more.	<ul style="list-style-type: none">Harness or connectors (CAN communication line is open or shorted)
U1001*2 1001*2		<ul style="list-style-type: none">When ECM is not transmitting or receiving CAN communication signal other than OBD (emission-related diagnosis) for 2 seconds or more.	

*1: This self-diagnosis has the one trip detection logic.

*2: The MIL will not light up for this diagnosis.

DTC Confirmation Procedure

UBS00P28



1. Turn ignition switch ON and wait at least 3 seconds.
2. Select "DATA MONITOR" mode with CONSULT-II.
3. If 1st trip DTC is detected, go to [EC-161, "Diagnostic Procedure"](#).

DTC U1000, U1001 CAN COMMUNICATION LINE

UBS00P29

Wiring Diagram

EC-CAN-01

-  : DETECTABLE LINE FOR DTC
-  : NON-DETECTABLE LINE FOR DTC
-  : DATA LINE

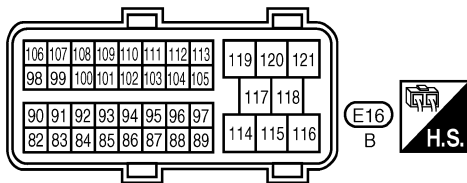
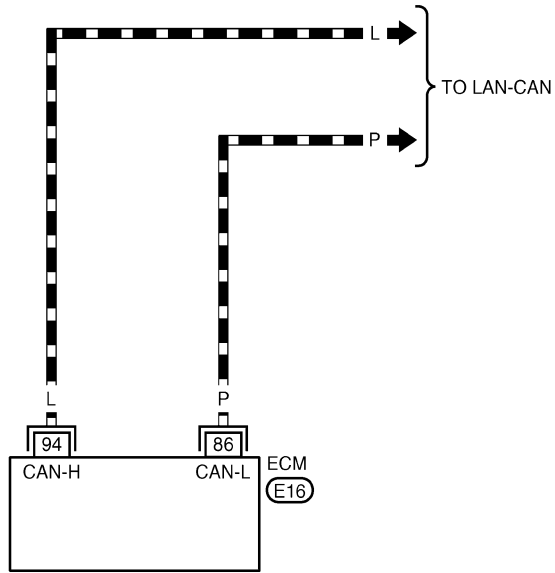

BBWA2502E

DTC U1000, U1001 CAN COMMUNICATION LINE

Diagnostic Procedure

UBS00P2A

Go to [LAN-44, "CAN Diagnostic Support Monitor"](#) .

A

EC

C

D

E

F

G

H

I

J

K

L

M

DTC U1010 CAN COMMUNICATION

DTC U1010 CAN COMMUNICATION

PFP:23710

Description

UBS00P2B

CAN (Controller Area Network) is a serial communication line for real time application. It is an on-vehicle multiplex communication line with high data communication speed and excellent error detection ability. Many electronic control units are equipped onto a vehicle, and each control unit shares information and links with other control units during operation (not independent). In CAN communication, control units are connected with 2 communication lines (CAN H line, CAN L line) allowing a high rate of information transmission with less wiring. Each control unit transmits/receives data but selectively reads required data only.

On Board Diagnosis Logic

UBS00P2C

This self-diagnosis has the one trip detection logic.

DTC No.	Trouble diagnosis name	DTC detecting condition	Possible cause
U1010 1010	CAN communication bus	When detecting error during the initial diagnosis for CAN controller of each control unit.	● ECM

DTC Confirmation Procedure

UBS00P2D

WITH CONSULT-II

1. Turn ignition switch ON.
2. Select "DATA MONITOR" mode with CONSULT-II.
3. If DTC is detected, go to [EC-163, "Diagnostic Procedure"](#) .

DATA MONITOR	
MONITOR	NO DTC
ENG SPEED	XXX rpm

SEF058Y

WITH GST

Follow the procedure "WITH CONSULT-II" above.

DTC U1010 CAN COMMUNICATION

UBS00P2E

Diagnostic Procedure

1. INSPECTION START

With CONSULT-II

1. Turn ignition switch ON.
2. Select "SELF-DIAG RESULTS" mode with CONSULT-II.
3. Touch "ERASE".
4. **Perform DTC Confirmation Procedure.**
See [EC-162, "DTC Confirmation Procedure"](#) .
5. Is the DTC U1010 displayed again?

With GST

1. Turn ignition switch ON.
2. Select Service \$04 with GST.
3. **Perform DTC Confirmation Procedure.**
See [EC-162, "DTC Confirmation Procedure"](#) .
4. Is the DTC U1010 displayed again?

Yes or No

Yes >> GO TO 2.

No >> **INSPECTION END**

2. REPLACE ECM

1. Replace ECM.
2. Perform initialization of NVIS (NATS) system and registration of all NVIS (NATS) ignition key IDs. Refer to [BL-203, "NVIS\(NISSAN Vehicle Immobilizer System-NATS\)"](#) .
3. Perform [EC-79, "VIN Registration"](#) .
4. Perform [EC-80, "Accelerator Pedal Released Position Learning"](#) .
5. Perform [EC-80, "Throttle Valve Closed Position Learning"](#) .
6. Perform [EC-80, "Idle Air Volume Learning"](#) .

>> **INSPECTION END**

A

EC

C

D

E

F

G

H

I

J

K

L

M

DTC P0011, P0021 IVT CONTROL

PFP:23796

DTC P0011, P0021 IVT CONTROL

Description SYSTEM DESCRIPTION

UBS00P2F

Sensor	Input signal to ECM	ECM function	Actuator
Crankshaft position sensor (POS)	Engine speed and piston position	Intake valve timing control	Intake valve timing control solenoid valve
Camshaft position sensor (PHASE)			
Engine coolant temperature sensor	Engine coolant temperature		
Wheel sensor	Vehicle speed*		

*: Signal is sent to the ECM through CAN communication line.

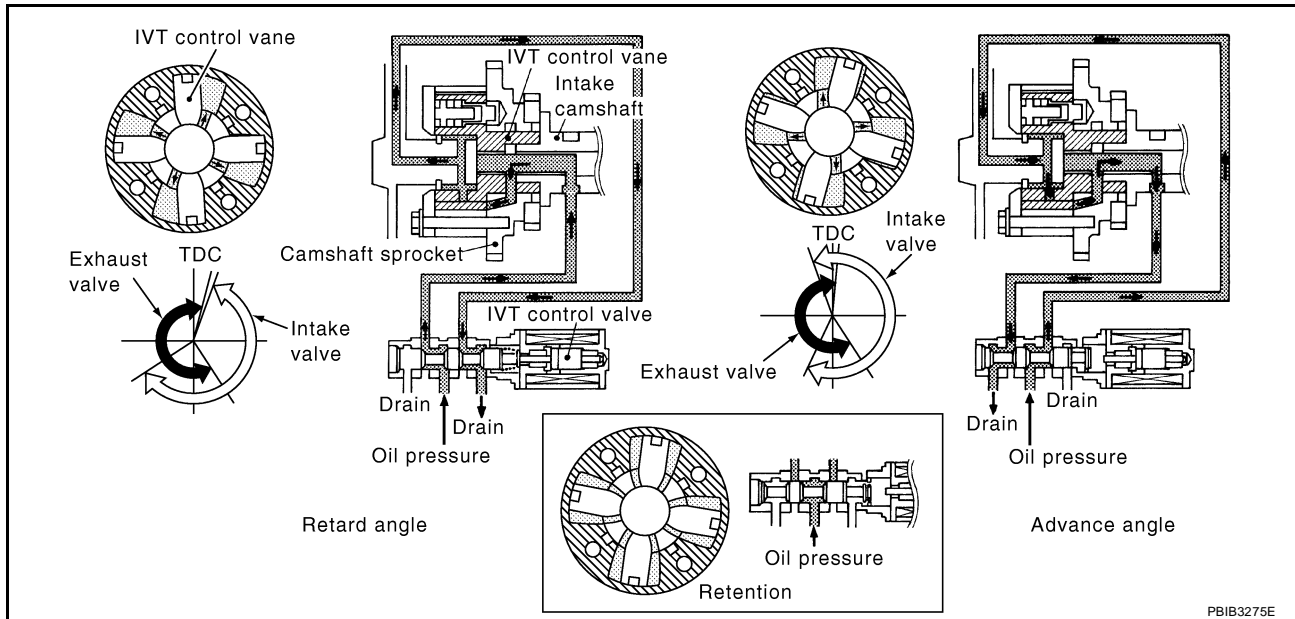

PBIB3275E

This mechanism hydraulically controls cam phases continuously with the fixed operating angle of the intake valve.

The ECM receives signals such as crankshaft position, camshaft position, engine speed, and engine coolant temperature. Then, the ECM sends ON/OFF pulse duty signals to the intake valve timing control solenoid valve depending on driving status. This makes it possible to control the shut/open timing of the intake valve to increase engine torque in low/mid speed range and output in high-speed range.

CONSULT-II Reference Value in Data Monitor Mode

UBS00P2G

Specification data are reference values.

MONITOR ITEM	CONDITION	SPECIFICATION
INT/V TIM (B1) INT/V TIM (B2)	● Engine: After warming up ● Shift lever: P or N ● Air conditioner switch: OFF ● No load	Idle -5° - 5°C
	2,000 rpm	Approx. 0° - 30°C
INT/V SOL (B1) INT/V SOL (B2)	● Engine: After warming up ● Shift lever: P or N ● Air conditioner switch: OFF ● No load	Idle 0% - 2%
	2,000 rpm	Approx. 0% - 50%

DTC P0011, P0021 IVT CONTROL

On Board Diagnosis Logic

UBS00P2H

DTC No.	Trouble diagnosis name	Detecting condition	Possible cause
P0011 0011 (Bank 1)	Intake valve timing control performance	There is a gap between angle of target and phase-control angle degree.	<ul style="list-style-type: none"> ● Crankshaft position sensor (POS) ● Camshaft position sensor (PHASE) ● Intake valve control solenoid valve ● Accumulation of debris to the signal pick-up portion of the camshaft ● Timing chain installation ● Foreign matter caught in the oil groove for intake valve timing control
P0021 0021 (Bank 2)			

A
EC
C
D

FAIL-SAFE MODE

When the malfunction is detected, the ECM enters fail-safe mode.

Detected items	Engine operating condition in fail-safe mode
Intake valve timing control	The signal is not energized to the solenoid valve and the valve control does not function.

E
F

DTC Confirmation Procedure

UBS00P2I

NOTE:

- If DTC P0011 or P0021 is displayed with DTC P0075 or P0081, first perform trouble diagnosis for DTC P0075 or P0081. Refer to [EC-185, "DTC P0075, P0081 IVT CONTROL SOLENOID VALVE"](#).
- If DTC Confirmation Procedure has been previously conducted, always turn ignition switch OFF and wait at least 10 seconds before conducting the next test.

G
H

TESTING CONDITION:

Before performing the following procedure, confirm that battery voltage is between 10V and 16V at idle.

I

WITH CONSULT-II

1. Turn ignition switch ON and select "DATA MONITOR" mode with CONSULT-II.
2. Start engine and warm it up to the normal operating temperature.
3. Maintain the following conditions for at least 6 consecutive seconds.
Hold the accelerator pedal as steady as possible.

DATA MONITOR	
MONITOR	NO DTC
ENG SPEED	XXX rpm
COOLAN TEMP/S	XXX °C
VHCL SPEED SE	XXX km/h
B/FUEL SCHDL	XXX msec

PBIB0164E

J
K
L
M

ENG SPEED	1,200 - 2,000 rpm
COOLAN TEMP/S	More than 60°C (140°F)
B/FUEL SCHDL	More than 3.4 msec
Shift lever	P or N position

4. Let engine idle for 10 seconds.
5. If 1st trip DTC is detected, go to [EC-166, "Diagnostic Procedure"](#).
If 1st trip DTC is not detected, go to next step.
6. Maintain the following conditions for at least 20 consecutive seconds.

ENG SPEED	1,700 - 3,175 rpm (A constant rotation is maintained.)
COOLAN TEMP/S	70 - 105°C (158 - 221°F)
Shift lever	1st or 2nd position
Driving location uphill	Driving vehicle uphill (Increased engine load will help maintain the driving conditions required for this test.)

7. If 1st trip DTC is detected, go to [EC-166, "Diagnostic Procedure"](#).

DTC P0011, P0021 IVT CONTROL

WITH GST

Follow the procedure "WITH CONSULT-II" above.

Diagnostic Procedure

UBS00P2J

1. CHECK OIL PRESSURE WARNING LAMP

1. Start engine.
2. Check oil pressure warning lamp and confirm it is not illuminated.

OK or NG

- OK >> GO TO 2.
KG >> Go to [LU-8, "ENGINE OIL PRESSURE CHECK"](#).

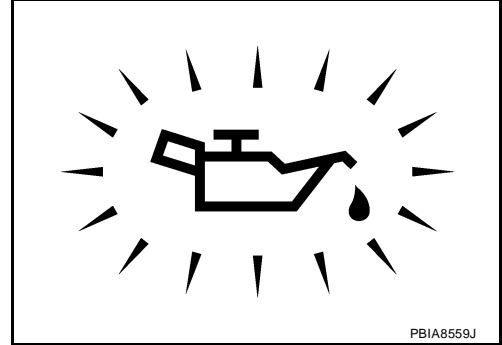

2. CHECK INTAKE VALVE TIMING CONTROL SOLENOID VALVE

Refer to [EC-167, "Component Inspection"](#).

OK or NG

- OK >> GO TO 3.
NG >> Replace intake valve timing control solenoid valve.

3. CHECK CRANKSHAFT POSITION SENSOR (POS)

Refer to [EC-386, "Component Inspection"](#).

OK or NG

- OK >> GO TO 4.
NG >> Replace crankshaft position sensor (POS).

4. CHECK CAMSHAFT POSITION SENSOR (PHASE)

Refer to [EC-396, "Component Inspection"](#).

OK or NG

- OK >> GO TO 5.
NG >> Replace camshaft position sensor (PHASE).

5. CHECK CAMSHAFT (INTAKE)

Check the following.

- Accumulation of debris to the signal plate of camshaft rear end
- Chipping signal plate of camshaft rear end

OK or NG

- OK >> GO TO 6.
NG >> Remove debris and clean the signal plate of camshaft rear end or replace camshaft.

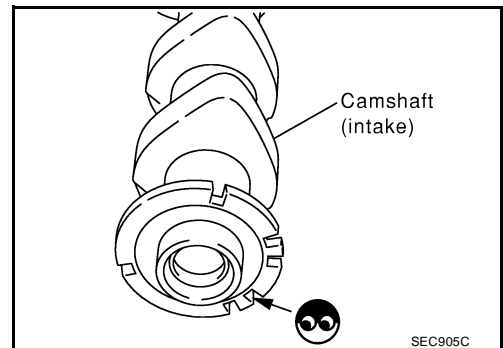

DTC P0011, P0021 IVT CONTROL

6. CHECK TIMING CHAIN INSTALLATION

Check service records for any recent repairs that may cause timing chain misaligned.
Are there any service records that may cause timing chain misaligned?

Yes or No

- Yes >> Check timing chain installation. Refer to [EM-56, "TIMING CHAIN"](#).
- No >> GO TO 7.

7. CHECK LUBRICATION CIRCUIT

Refer to [EM-87, "Inspection After Installation"](#).

OK or NG

- OK >> GO TO 8.
- NG >> Clean lubrication line.

8. CHECK INTERMITTENT INCIDENT

Refer to [EC-149, "TROUBLE DIAGNOSIS FOR INTERMITTENT INCIDENT"](#).

For Wiring Diagram, refer to [EC-381](#) for CKP sensor (POS) and [EC-389](#) for CMP sensor (PHASE).

>> INSPECTION END

Component Inspection INTAKE VALVE TIMING CONTROL SOLENOID VALVE

UBS00P2K

1. Disconnect intake valve timing control solenoid valve harness connector.
2. Check resistance between intake valve timing control solenoid valve as follows.

Terminal	Resistance
1 and 2	7.0 - 7.5Ω [at 20°C (68°F)]
1 or 2 and ground	∞Ω (Continuity should not exist.)

If NG, replace intake valve timing control solenoid valve.
If OK, go to next step.

3. Remove intake valve timing control solenoid valve.
4. Provide 12V DC between intake valve timing control solenoid valve terminals and then interrupt it. Make sure that the plunger moves as shown in the figure.

CAUTION:

Do not apply 12V DC continuously for 5 seconds or more. Doing so may result in damage to the coil in intake valve timing control solenoid valve.

If NG, replace intake valve timing control solenoid valve.

NOTE:

Always replace O-ring when intake valve timing control solenoid valve is removed.

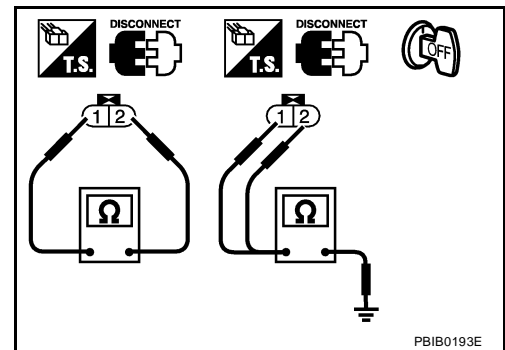

PBIB0193E

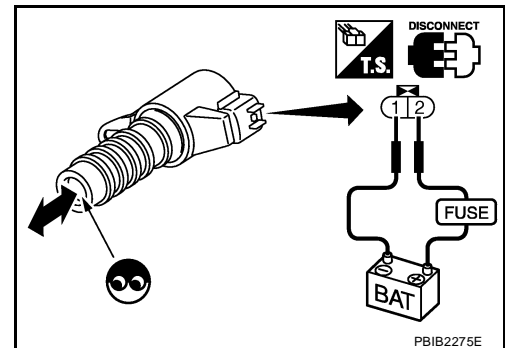

PBIB2275E

Removal and Installation INTAKE VALVE TIMING CONTROL SOLENOID VALVE

UBS00P2L

Refer to [EM-56, "TIMING CHAIN"](#).

DTC P0031, P0032, P0051, P0052 A/F SENSOR 1 HEATER

DTC P0031, P0032, P0051, P0052 A/F SENSOR 1 HEATER

PF#:22693

Description SYSTEM DESCRIPTION

UBS00P2M

Sensor	Input Signal to ECM	ECM function	Actuator
Camshaft position sensor (PHASE) Crankshaft position sensor (POS)	Engine speed	Air fuel ratio (A/F) sensor 1 heater control	Air fuel ratio (A/F) sensor 1 heater
Mass air flow sensor	Amount of intake air		

The ECM performs ON/OFF duty control of the A/F sensor 1 heater corresponding to the engine operating condition to keep the temperature of A/F sensor 1 element at the specified range.

CONSULT-II Reference Value in Data Monitor Mode

UBS00P2N

Specification data are reference values.

MONITOR ITEM	CONDITION	SPECIFICATION
A/F S1 HTR (B1) A/F S1 HTR (B2)	● Engine: After warming up, idle the engine	0 - 100%

On Board Diagnosis Logic

UBS00P2O

DTC No.	Trouble diagnosis name	DTC detecting condition	Possible cause
P0031 0031 (Bank 1) P0051 0051 (Bank 2)	Air fuel ratio (A/F) sensor 1 heater control circuit low	The current amperage in the air fuel ratio (A/F) sensor 1 heater circuit is out of the normal range. (An excessively low voltage signal is sent to ECM through the air fuel ratio (A/F) sensor 1 heater.)	<ul style="list-style-type: none"> ● Harness or connectors (The A/F sensor 1 heater circuit is open or shorted.) ● A/F sensor 1 heater
P0032 0032 (Bank 1) P0052 0052 (Bank 2)	Air fuel ratio (A/F) sensor 1 heater control circuit high	The current amperage in the air fuel ratio (A/F) sensor 1 heater circuit is out of the normal range. (An excessively high voltage signal is sent to ECM through the air fuel ratio (A/F) sensor 1 heater.)	<ul style="list-style-type: none"> ● Harness or connectors (The A/F sensor 1 heater circuit is shorted.) ● A/F sensor 1 heater

DTC Confirmation Procedure

UBS00P2P

NOTE:

If DTC Confirmation Procedure has been previously conducted, always turn ignition switch OFF and wait at least 10 seconds before conducting the next test.

TESTING CONDITION:

Before performing the following procedure, confirm that battery voltage is between 10.5V and 16V at idle.

With CONSULT-II

④ WITH CONSULT-II

1. Turn ignition switch ON and select "DATA MONITOR" mode with CONSULT-II.
2. Start engine and let it idle for at least 10 seconds.
3. If 1st trip DTC is detected, go to [EC-173, "Diagnostic Procedure"](#)

DATA MONITOR	
MONITOR	NO DTC
ENG SPEED	XXX rpm

SEF058Y

④ WITH GST

Follow the procedure "WITH CONSULT-II" above.

DTC P0031, P0032, P0051, P0052 A/F SENSOR 1 HEATER

UBS00P2Q

Wiring Diagram BANK 1

EC-AF1HB1-01

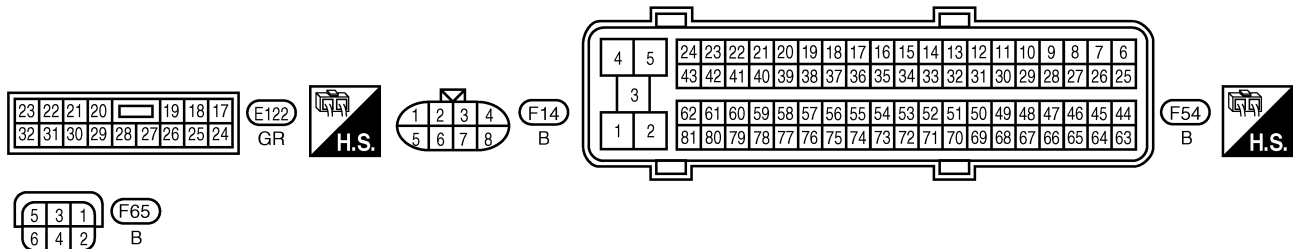
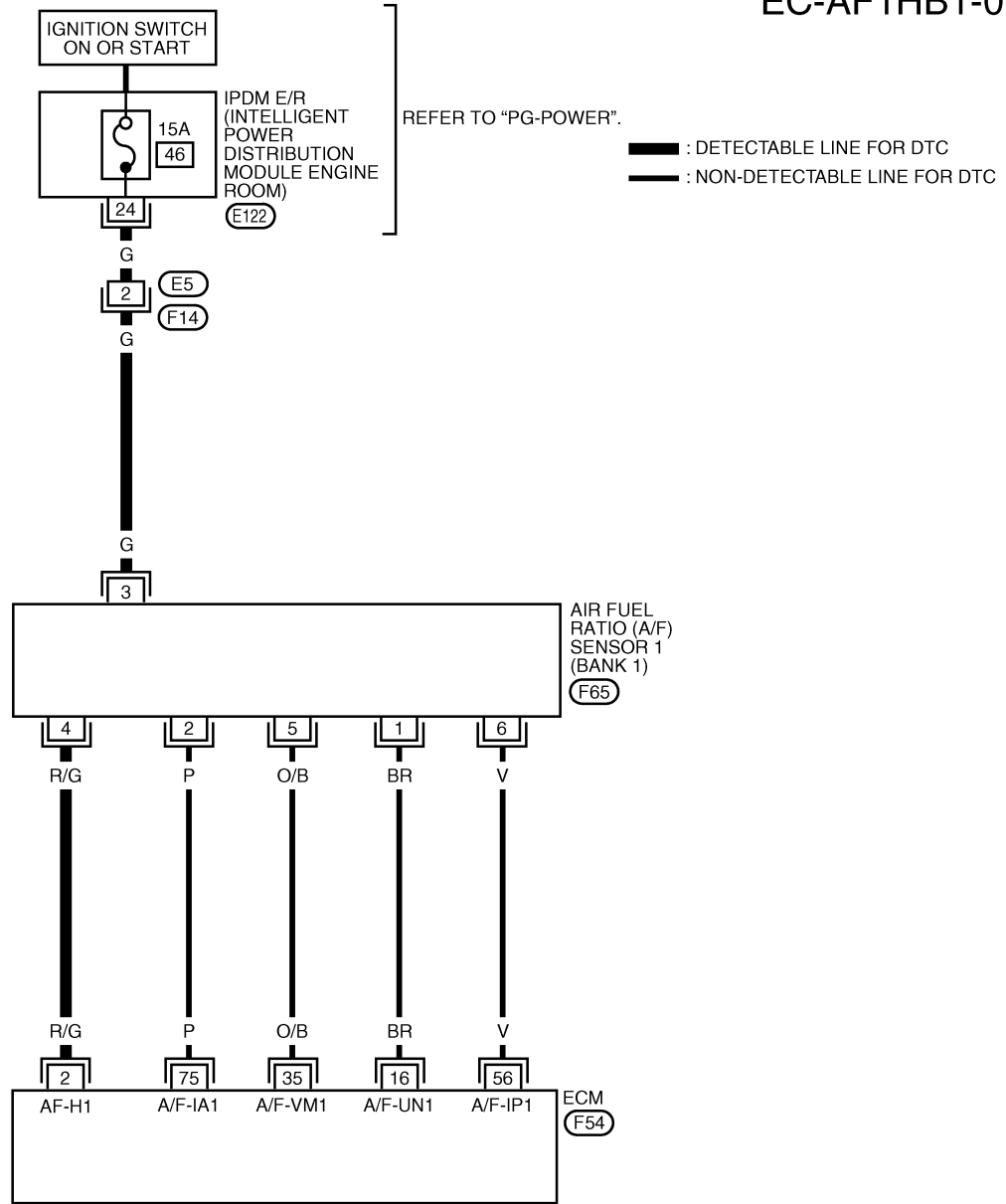

BBWA2505E

DTC P0031, P0032, P0051, P0052 A/F SENSOR 1 HEATER

Specification data are reference values and are measured between each terminal and ground.
Pulse signal is measured by CONSULT-II.

CAUTION:

Do not use ECM ground terminals when measuring input/output voltage. Doing so may result in damage to the ECM's transistor. Use a ground other than ECM terminals, such as the ground.

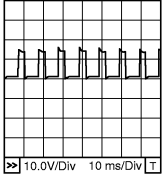
TERMI- NAL NO.	WIRE COLOR	ITEM	CONDITION	DATA (DC Voltage)
2	R/G	A/F sensor 1 heater (Bank 1)	[Engine is running] <ul style="list-style-type: none"> ● Warm-up condition ● Idle speed 	Approximately 5V★  <small>PBIB1584E</small>
16	BR	A/F sensor 1 (Bank 1)	[Engine is running] <ul style="list-style-type: none"> ● Warm-up condition ● Idle speed 	Approximately 3.1V
35	O/B			Approximately 2.6V
56	V			Approximately 2.3V
75	P			Approximately 2.3V

★: Average voltage for pulse signal (Actual pulse signal can be confirmed by oscilloscope.)

DTC P0031, P0032, P0051, P0052 A/F SENSOR 1 HEATER

BANK 2

EC-AF1HB2-01

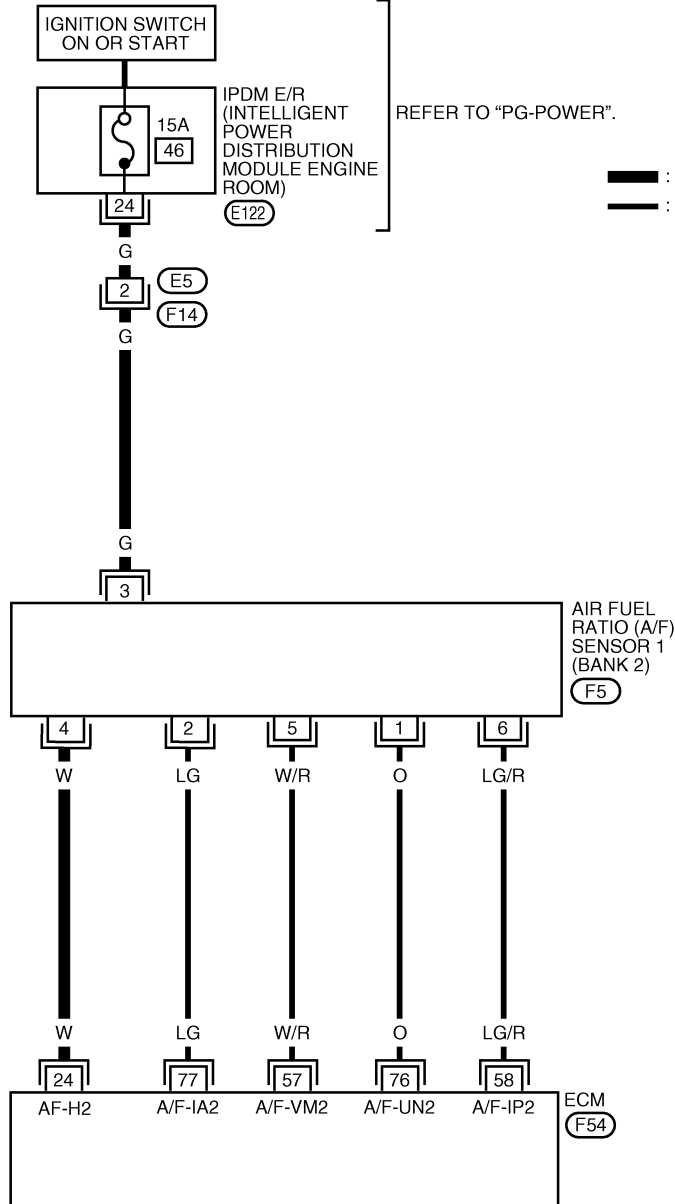

— : DETECTABLE LINE FOR DTC
 — : NON-DETECTABLE LINE FOR DTC

A
 EC
 C
 D
 E
 F
 G
 H
 I
 J
 K
 L
 M

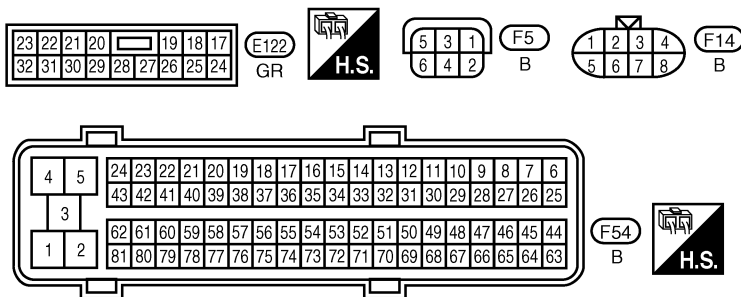

BBWA2506E

DTC P0031, P0032, P0051, P0052 A/F SENSOR 1 HEATER

Specification data are reference values and are measured between each terminal and ground.
Pulse signal is measured by CONSULT-II.

CAUTION:

Do not use ECM ground terminals when measuring input/output voltage. Doing so may result in damage to the ECM's transistor. Use a ground other than ECM terminals, such as the ground.

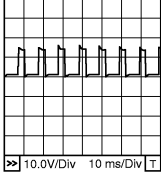
TERMI- NAL NO.	WIRE COLOR	ITEM	CONDITION	DATA (DC Voltage)
24	W	A/F sensor 1 heater (Bank 2)	[Engine is running] <ul style="list-style-type: none"> ● Warm-up condition ● Idle speed 	Approximately 5V★  <small>PBIB1584E</small>
57	W/R	A/F sensor 1 (Bank 2)	[Engine is running] <ul style="list-style-type: none"> ● Warm-up condition ● Idle speed 	Approximately 2.6V
58	LG/R			Approximately 2.3V
76	O			Approximately 3.1V
77	LG			Approximately 2.3V

★: Average voltage for pulse signal (Actual pulse signal can be confirmed by oscilloscope.)

DTC P0031, P0032, P0051, P0052 A/F SENSOR 1 HEATER

UBS00P2R

Diagnostic Procedure

1. CHECK GROUND CONNECTIONS

1. Turn ignition switch OFF.
2. Loosen and retighten three ground screws on the body. Refer to [EC-158, "Ground Inspection"](#).

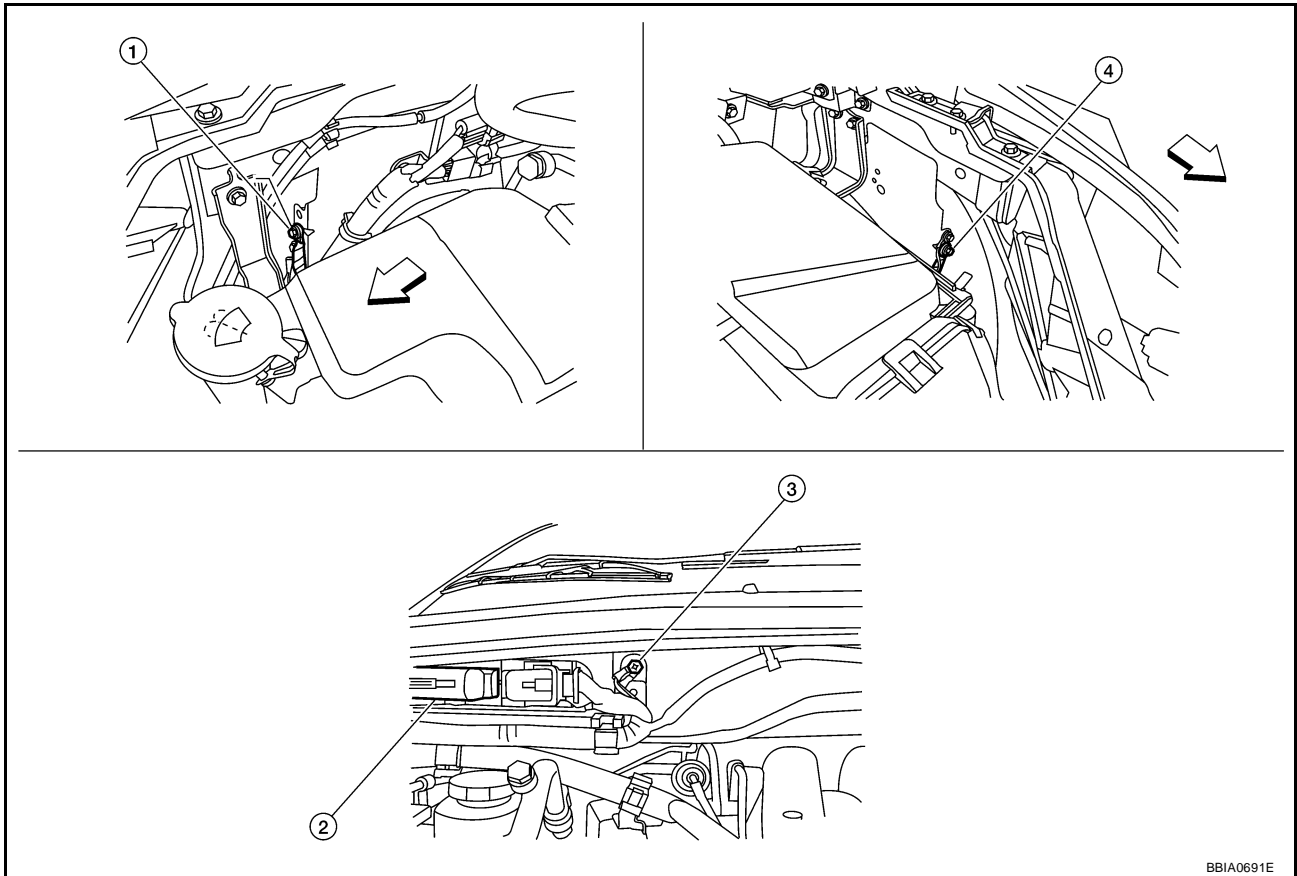

↔ Vehicle front

1. Body ground E24

2. ECM

3. Body ground E9

4. Body ground E15

OK or NG

OK >> GO TO 2.

NG >> Repair or replace ground connections.

BBIA0691E

DTC P0031, P0032, P0051, P0052 A/F SENSOR 1 HEATER

2. CHECK AIR FUEL RATIO (A/F) SENSOR 1 POWER SUPPLY CIRCUIT

1. Disconnect air fuel ratio (A/F) sensor 1 harness connector.

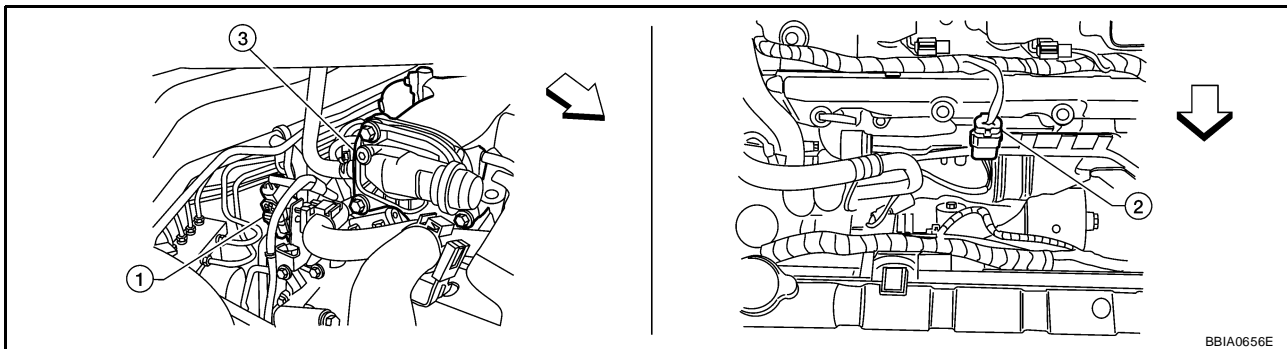

← Vehicle front

1. Air fuel ratio (A/F) sensor 1 (bank 1) harness connector
 2. Air fuel ratio (A/F) sensor 1 (bank 2) harness connector
 3. Intake manifold collector harness connector
2. Turn ignition switch ON.
 3. Check voltage between A/F sensor 1 terminal 3 and ground with CONSULT-II or tester.

Voltage: Battery voltage

OK or NG

- OK >> GO TO 4.
- NG >> GO TO 3.

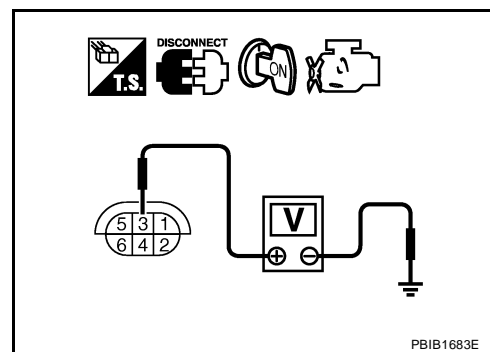

3. DETECT MALFUNCTIONING PART

Check the following.

- Harness connectors E5, F14
- IPDM E/R harness connector E122
- 15A fuse
- Harness for open or short between A/F sensor 1 and fuse

>> Repair or replace harness or connectors.

4. CHECK A/F SENSOR 1 HEATER OUTPUT SIGNAL CIRCUIT

1. Turn ignition switch OFF.
2. Disconnect ECM harness connector.
3. Check harness continuity between ECM terminal 2 (bank 1) or 24 (bank 2) and A/F sensor 1 terminal 4. Refer to Wiring Diagram.

Continuity should exist.

4. Also check harness for short to ground and short to power.

OK or NG

- OK >> GO TO 5.
- NG >> Repair open circuit or short to ground or short to power in harness or connectors.

DTC P0031, P0032, P0051, P0052 A/F SENSOR 1 HEATER

5. CHECK A/F SENSOR 1 HEATER

Refer to [EC-175, "Component Inspection"](#) .

OK or NG

- OK >> GO TO 6.
- NG >> GO TO 7.

6. CHECK INTERMITTENT INCIDENT

Perform [EC-149, "TROUBLE DIAGNOSIS FOR INTERMITTENT INCIDENT"](#) .

OK or NG

- OK >> GO TO 7.
- NG >> Repair or replace.

7. REPLACE AIR FUEL RATIO (A/F) SENSOR 1

Replace malfunctioning air fuel ratio (A/F) sensor 1.

CAUTION:

- Discard any air fuel ratio (A/F) sensor which has been dropped from a height of more than 0.5 m (19.7 in) onto a hard surface such as a concrete floor; use a new one.
- Before installing new air fuel ratio (A/F) sensor, clean exhaust system threads using Heated Oxygen Sensor Thread Cleaner tool J-43897-18 or J-43897-12 and approved anti-seize lubricant.

>> INSPECTION END

Component Inspection AIR FUEL RATIO (A/F) SENSOR 1 HEATER

UBS00P2S

Check resistance between terminals 3 and 4.

Resistance: 2.3 - 4.3Ω [at 25°C (77°F)]

Check continuity between terminals 3 and 1, 2, 5, 6, terminals 4 and 1, 2, 5, 6.

Continuity should not exist.

If NG, replace the A/F sensor 1.

CAUTION:

- Discard any A/F sensor which has been dropped from a height of more than 0.5 m (19.7 in) onto a hard surface such as a concrete floor; use a new one.
- Before installing new A/F sensor, clean exhaust system threads using Heated Oxygen Sensor Thread Cleaner tool J-43897-18 or J-43897-12 and approved anti-seize lubricant.

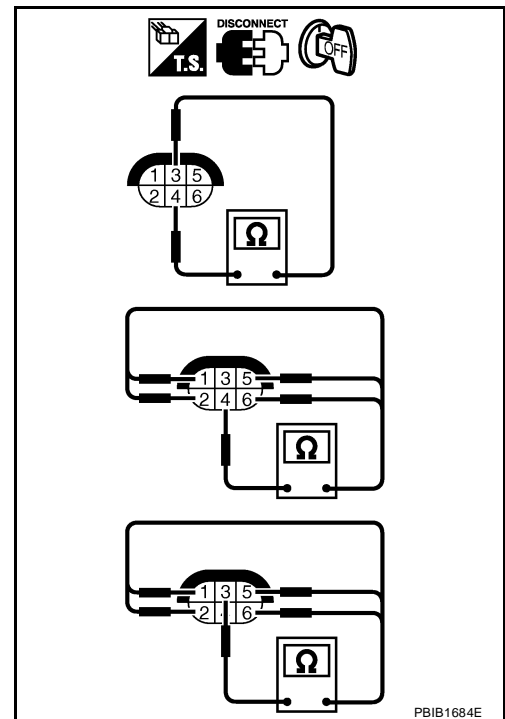

UBS00P2T

Removal and Installation AIR FUEL RATIO (A/F) SENSOR 1

Refer to [EM-26, "EXHAUST MANIFOLD AND THREE WAY CATALYST"](#) .

DTC P0037, P0038, P0057, P0058 HO2S2 HEATER

DTC P0037, P0038, P0057, P0058 HO2S2 HEATER

PF2:226A0

Description SYSTEM DESCRIPTION

UBS00P2U

Sensor	Input signal to ECM	ECM function	Actuator
Camshaft position sensor (PHASE)	Engine speed	Heated oxygen sensor 2 heater control	Heated oxygen sensor 2 heater
Crankshaft position sensor (POS)			
Engine coolant temperature sensor	Engine coolant temperature		
Mass air flow sensor	Amount of intake air		

The ECM performs ON/OFF control of the heated oxygen sensor 2 heater corresponding to the engine speed, amount of intake air and engine coolant temperature.

OPERATION

Engine speed rpm	Heated oxygen sensor 2 heater
Above 3,600	OFF
Below 3,600 rpm after the following conditions are met.	ON
<ul style="list-style-type: none"> ● Engine: After warming up ● Keeping the engine speed between 3,500 and 4,000 rpm for 1 minute and at idle for 1 minute under no load 	

CONSULT-II Reference Value in Data Monitor Mode

UBS00P2V

Specification data are reference values.

MONITOR ITEM	CONDITION	SPECIFICATION
HO2S2 HTR (B1) HO2S2 HTR (B2)	<ul style="list-style-type: none"> ● Engine speed: Above 3,600 rpm 	OFF
	<ul style="list-style-type: none"> ● Engine speed: Below 3,600 rpm after the following conditions are met – Engine: After warming up – Keeping the engine speed between 3,500 and 4,000 rpm for 1 minute and at idle for 1 minute under no load 	ON

On Board Diagnosis Logic

UBS00P2W

DTC No.	Trouble diagnosis name	DTC detecting condition	Possible cause
P0037 0037 (Bank 1)	Heated oxygen sensor 2 heater control circuit low	The current amperage in the heated oxygen sensor 2 heater circuit is out of the normal range. (An excessively low voltage signal is sent to ECM through the heated oxygen sensor 2 heater.)	<ul style="list-style-type: none"> ● Harness or connectors (The heated oxygen sensor 2 heater circuit is open or shorted.) ● Heated oxygen sensor 2 heater
P0057 0057 (Bank 2)			
P0038 0038 (Bank 1)	Heated oxygen sensor 2 heater control circuit high	The current amperage in the heated oxygen sensor 2 heater circuit is out of the normal range. (An excessively high voltage signal is sent to ECM through the heated oxygen sensor 2 heater.)	<ul style="list-style-type: none"> ● Harness or connectors (The heated oxygen sensor 2 heater circuit is shorted.) ● Heated oxygen sensor 2 heater
P0058 0058 (Bank 2)			

DTC P0037, P0038, P0057, P0058 HO2S2 HEATER

UBS00P2X

DTC Confirmation Procedure

NOTE:

If DTC Confirmation Procedure has been previously conducted, always turn ignition switch OFF and wait at least 10 seconds before conducting the next test.

TESTING CONDITION:

Before performing the following procedure, confirm that battery voltage is between 10.5V and 16V at idle.

WITH CONSULT-II

1. Turn ignition switch ON and select "DATA MONITOR" mode with CONSULT-II.
2. Start engine and warm it up to the normal operating temperature.
3. Turn ignition switch OFF and wait at least 10 seconds.
4. Start the engine and keep the engine speed between 3,500 rpm and 4,000 rpm for at least 1 minute under no load.
5. Let engine idle for 1 minute.
6. If 1st trip DTC is detected, go to [EC-182, "Diagnostic Procedure"](#)

DATA MONITOR	
MONITOR	NO DTC
ENG SPEED	XXX rpm
COOLAN TEMP/S	XXX °C

SEF174Y

WITH GST

Follow the procedure "WITH CONSULT-II" above.

A

EC

C

D

E

F

G

H

I

J

K

L

M

DTC P0037, P0038, P0057, P0058 HO2S2 HEATER

UBS00P2Y

Wiring Diagram BANK 1

EC-O2H2B1-01

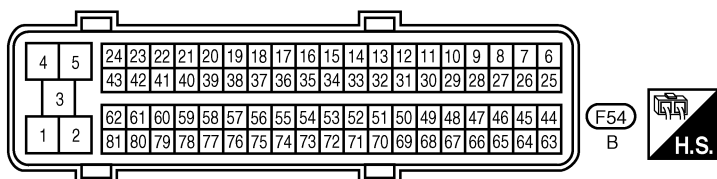
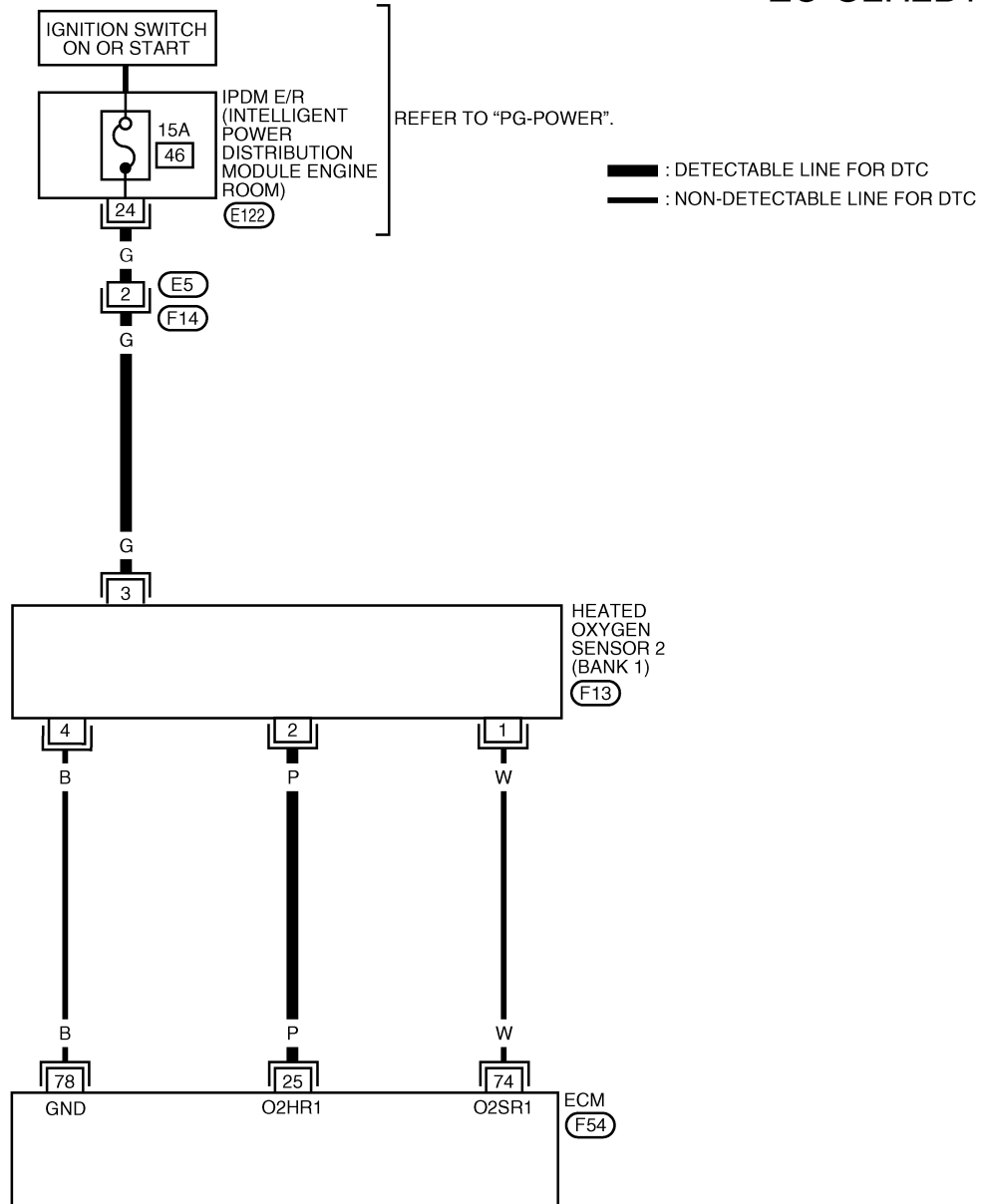

BBWA2507E

DTC P0037, P0038, P0057, P0058 HO2S2 HEATER

Specification data are reference values and are measured between each terminal and ground.

CAUTION:

Do not use ECM ground terminals when measuring input/output voltage. Doing so may result in damage to the ECM's transistor. Use a ground other than ECM terminals, such as the ground.

TER-MINAL NO.	WIRE COLOR	ITEM	CONDITION	DATA (DC Voltage)
25	P	Heated oxygen sensor 2 heater (bank 1)	[Engine is running] <ul style="list-style-type: none"> ● Engine speed: Below 3,600 rpm after the following conditions are met. <ul style="list-style-type: none"> – Engine: After warming up – Keeping the engine speed between 3,500 and 4,000 rpm for 1 minute and at idle for 1 minute under no load. 	0 - 1.0V
			[Ignition switch: ON] <ul style="list-style-type: none"> ● Engine stopped [Engine is running] <ul style="list-style-type: none"> ● Engine speed: Above 3,600 rpm. 	BATTERY VOLTAGE (11 - 14V)
74	W	Heated oxygen sensor 2 (Bank 1)	[Engine is running] <ul style="list-style-type: none"> ● Revving engine from idle to 3,000 rpm quickly after the following conditions are met <ul style="list-style-type: none"> – Engine: After warming up – Keeping the engine speed between 3,500 and 4,000 rpm for 1 minute and at idle for 1 minute under no load 	0 - Approximately 1.0V
78	B	Heated oxygen sensor 2 ground	[Engine is running] <ul style="list-style-type: none"> ● Warm-up condition ● Idle speed 	Approximately 0V

A
EC
C
D
E
F
G
H
I
J
K
L
M

DTC P0037, P0038, P0057, P0058 HO2S2 HEATER

BANK 2

EC-O2H2B2-01

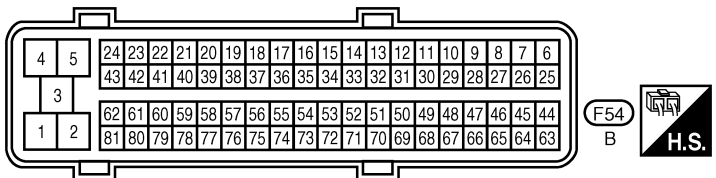
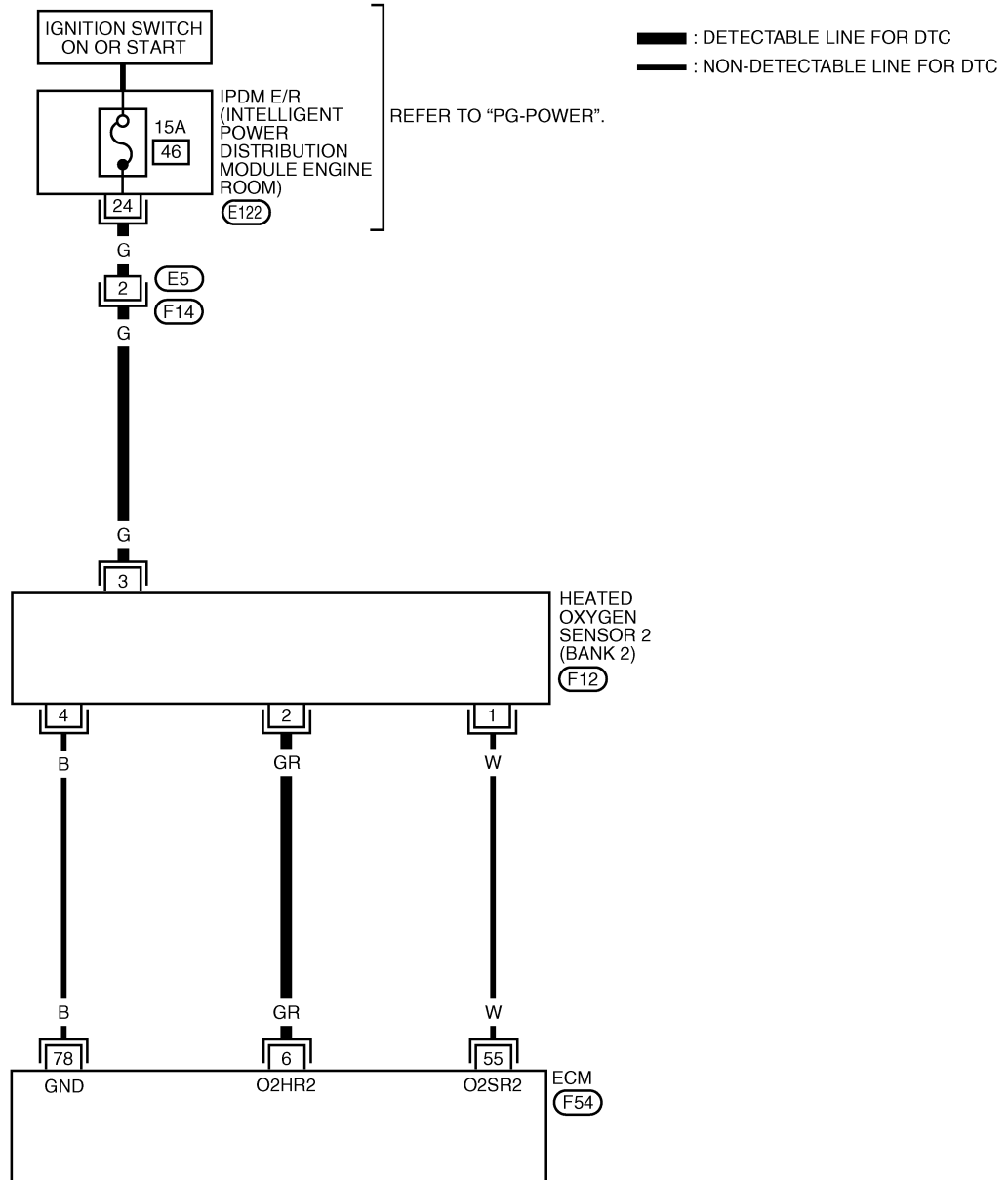

BBWA2508E

DTC P0037, P0038, P0057, P0058 HO2S2 HEATER

Specification data are reference values and are measured between each terminal and ground.

CAUTION:

Do not use ECM ground terminals when measuring input/output voltage. Doing so may result in damage to the ECM's transistor. Use a ground other than ECM terminals, such as the ground.

TER-MINAL NO.	WIRE COLOR	ITEM	CONDITION	DATA (DC Voltage)
6	GR	Heated oxygen sensor 2 heater (bank 2)	[Engine is running] <ul style="list-style-type: none"> ● Engine speed: Below 3,600 rpm after the following conditions are met. <ul style="list-style-type: none"> – Engine: After warming up – Keeping the engine speed between 3,500 and 4,000 rpm for 1 minute and at idle for 1 minute under no load. 	0 - 1.0V
			[Ignition switch: ON] <ul style="list-style-type: none"> ● Engine stopped [Engine is running] <ul style="list-style-type: none"> ● Engine speed: Above 3,600 rpm. 	BATTERY VOLTAGE (11 - 14V)
55	W	Heated oxygen sensor 2 (Bank 2)	[Engine is running] <ul style="list-style-type: none"> ● Revving engine from idle to 3,000 rpm quickly after the following conditions are met <ul style="list-style-type: none"> – Engine: After warming up – Keeping the engine speed between 3,500 and 4,000 rpm for 1 minute and at idle for 1 minute under no load 	0 - Approximately 1.0V
78	B	Heated oxygen sensor 2 ground	[Engine is running] <ul style="list-style-type: none"> ● Warm-up condition ● Idle speed 	Approximately 0V

A
EC
C
D
E
F
G
H
I
J
K
L
M

DTC P0037, P0038, P0057, P0058 HO2S2 HEATER

UBS00P2Z

Diagnostic Procedure

1. CHECK GROUND CONNECTIONS

1. Turn ignition switch OFF.
2. Loosen and retighten three ground screws on the body. Refer to [EC-158, "Ground Inspection"](#).

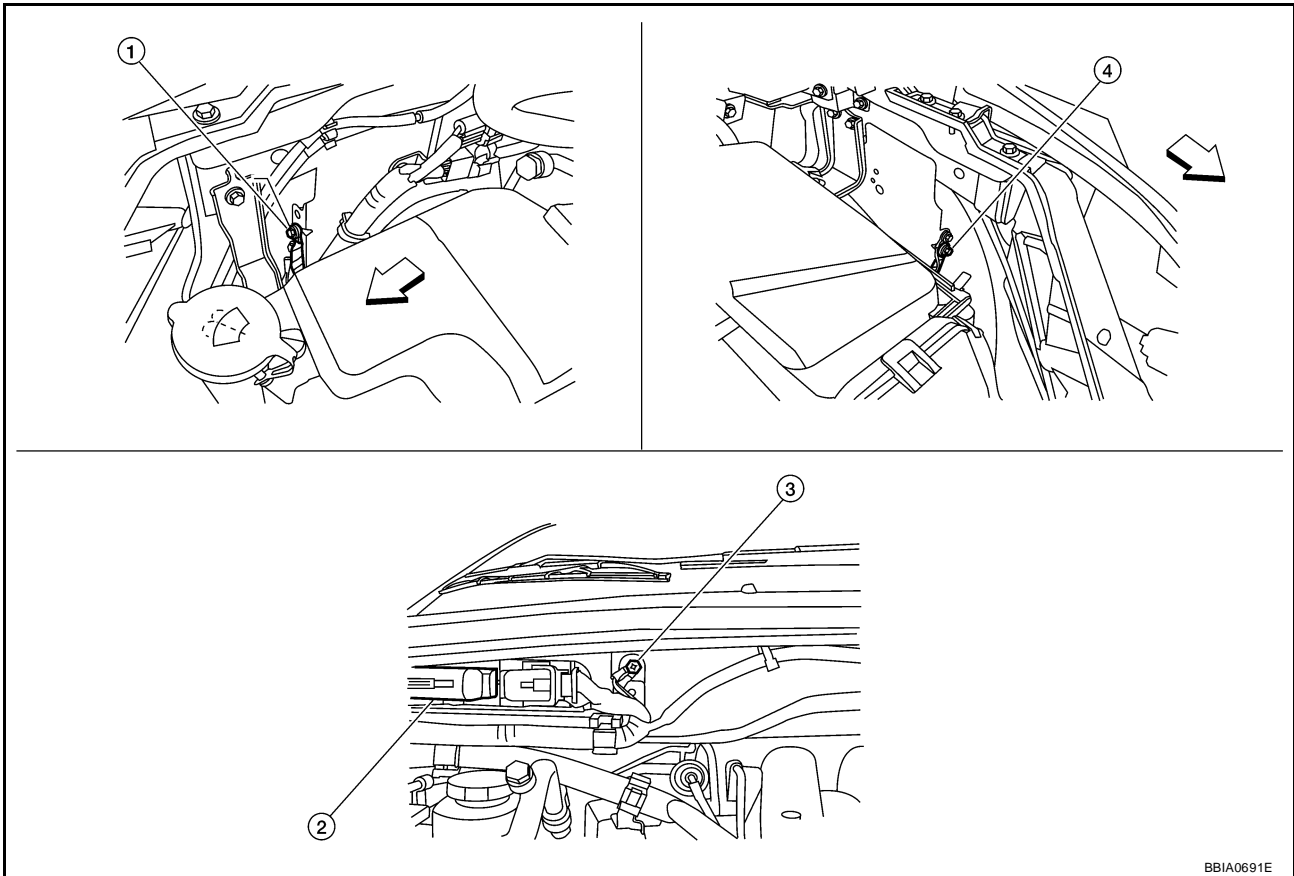

BBA0691E

← Vehicle front

1. Body ground E24

2. ECM

3. Body ground E9

4. Body ground E15

OK or NG

OK >> GO TO 2.

NG >> Repair or replace ground connections.

DTC P0037, P0038, P0057, P0058 HO2S2 HEATER

2. CHECK HO2S2 HEATER POWER SUPPLY CIRCUIT

1. Disconnect heated oxygen sensor 2 harness connector.
 - Oil pan (1)
 - Heated oxygen sensor 2 (bank 2) harness connector (2)
 - Heated oxygen sensor 2 (bank 1) harness connector (3)
2. Turn ignition switch ON.

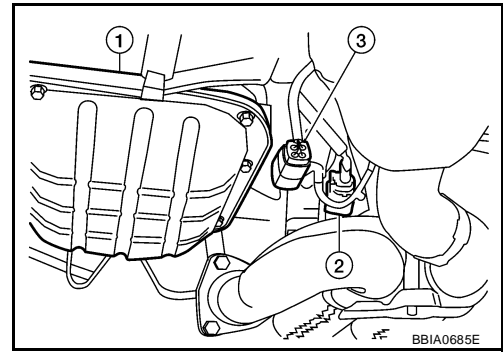

3. Check voltage between HO2S2 terminal 3 and ground with CONSULT-II or tester.

Voltage: Battery voltage

OK or NG

- OK >> GO TO 4.
- NG >> GO TO 3.

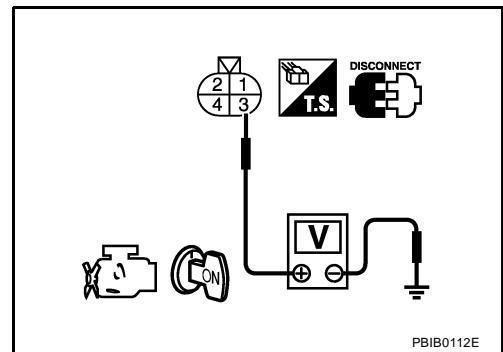

3. DETECT MALFUNCTIONING PART

Check the following.

- Harness connectors E5, F14
- IPDM E/R connector E122
- 15A fuse
- Harness for open or short between heated oxygen sensor 2 and fuse

>> Repair harness or connectors.

4. CHECK HO2S2 HEATER OUTPUT SIGNAL CIRCUIT FOR OPEN AND SHORT

1. Turn ignition switch OFF.
2. Disconnect ECM harness connector.
3. Check harness continuity between ECM terminal and HO2S2 terminal as follows. Refer to Wiring Diagram.

DTC	Terminals		Bank
	ECM	Sensor	
P0037, P0038	25	2	1
P0057, P0058	6	2	2

Continuity should exist.

4. Also check harness for short to ground and short to power.

OK or NG

- OK >> GO TO 5.
- NG >> Repair open circuit or short to ground or short to power in harness or connectors.

DTC P0037, P0038, P0057, P0058 HO2S2 HEATER

5. CHECK HEATED OXYGEN SENSOR 2 HEATER

Refer to [EC-184, "Component Inspection"](#) .

OK or NG

- OK >> GO TO 6.
- NG >> Replace malfunctioning heated oxygen sensor 2.

6. CHECK INTERMITTENT INCIDENT

Refer to [EC-149, "TROUBLE DIAGNOSIS FOR INTERMITTENT INCIDENT"](#) .

>> INSPECTION END

Component Inspection HEATED OXYGEN SENSOR 2 HEATER

UBS00P30

1. Check resistance between HO2S2 terminals as follows.

Terminal No.	Resistance
2 and 3	5.0 - 7.0 Ω [at 25°C (77°F)]
1 and 2, 3, 4	$\infty \Omega$
4 and 1, 2, 3	(Continuity should not exist)

2. If NG, replace heated oxygen sensor 2.

CAUTION:

- Discard any heated oxygen sensor which has been dropped from a height of more than 0.5 m (19.7 in) onto a hard surface such as a concrete floor; use a new one.
- Before installing new oxygen sensor, clean exhaust system threads using Oxygen Sensor Thread Cleaner tool J-43897-18 or J-43897-12 and approved anti-seize lubricant.

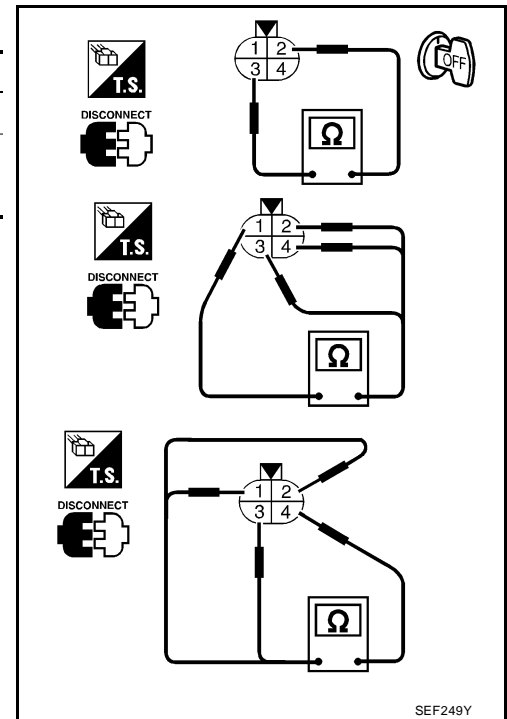

Removal and Installation HEATED OXYGEN SENSOR 2

UBS00P31

Refer to [EM-26, "EXHAUST MANIFOLD AND THREE WAY CATALYST"](#) .

DTC P0075, P0081 IVT CONTROL SOLENOID VALVE

DTC P0075, P0081 IVT CONTROL SOLENOID VALVE

PF2:23796

Component Description

UBS00P32

Intake valve timing control solenoid valve is activated by ON/OFF pulse duty (ratio) signals from the ECM.

The intake valve timing control solenoid valve changes the oil amount and direction of flow through intake valve timing control unit or stops oil flow.

The longer pulse width advances valve angle.

The shorter pulse width retards valve angle.

When ON and OFF pulse widths become equal, the solenoid valve stops oil pressure flow to fix the intake valve angle at the control position.

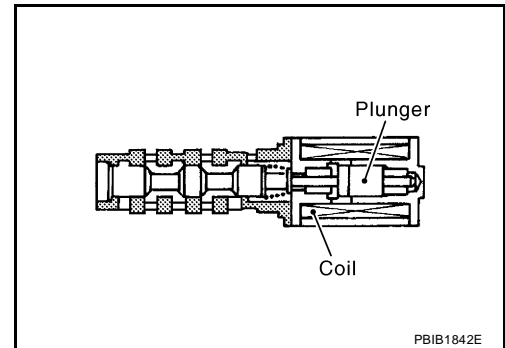

CONSULT-II Reference Value in Data Monitor Mode

UBS00P33

Specification data are reference values.

MONITOR ITEM	CONDITION	SPECIFICATION
INT/V SOL (B1) INT/V SOL (B2)	<ul style="list-style-type: none"> ● Engine: After warming up ● Shift lever: P or N 	Idle
	<ul style="list-style-type: none"> ● Air conditioner switch: OFF ● No load 	2,000 rpm
		0% - 2%
		Approx. 0% - 50%

On Board Diagnosis Logic

UBS00P34

DTC No.	Trouble diagnosis name	DTC detecting condition	Possible cause
P0075 0075 (Bank 1)	Intake valve timing control solenoid valve circuit	An improper voltage is sent to the ECM through intake valve timing control solenoid valve.	<ul style="list-style-type: none"> ● Harness or connectors (Intake valve timing control solenoid valve circuit is open or shorted.) ● Intake valve timing control solenoid valve
P0081 0081 (Bank 2)			

DTC Confirmation Procedure

UBS00P35

NOTE:

If DTC Confirmation Procedure has been previously conducted, always turn ignition switch OFF and wait at least 10 seconds before conducting the next test.

WITH CONSULT-II

1. Turn ignition switch ON.
2. Select "DATA MONITOR" mode with CONSULT-II.
3. Start engine and let it idle for 5 seconds.
4. If 1st trip DTC is detected, go to [EC-190, "Diagnostic Procedure"](#)

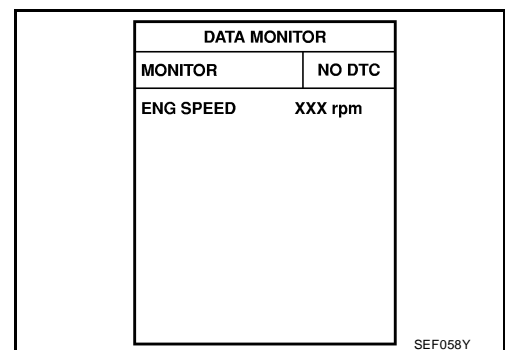

WITH GST

Following the procedure "WITH CONSULT-II" above.

DTC P0075, P0081 IVT CONTROL SOLENOID VALVE

UBS00P36

Wiring Diagram BANK 1

EC-IVCB1-01

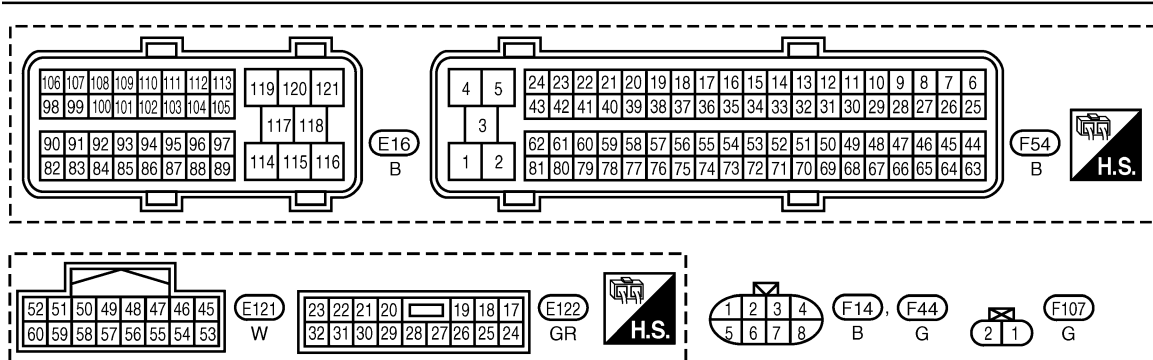
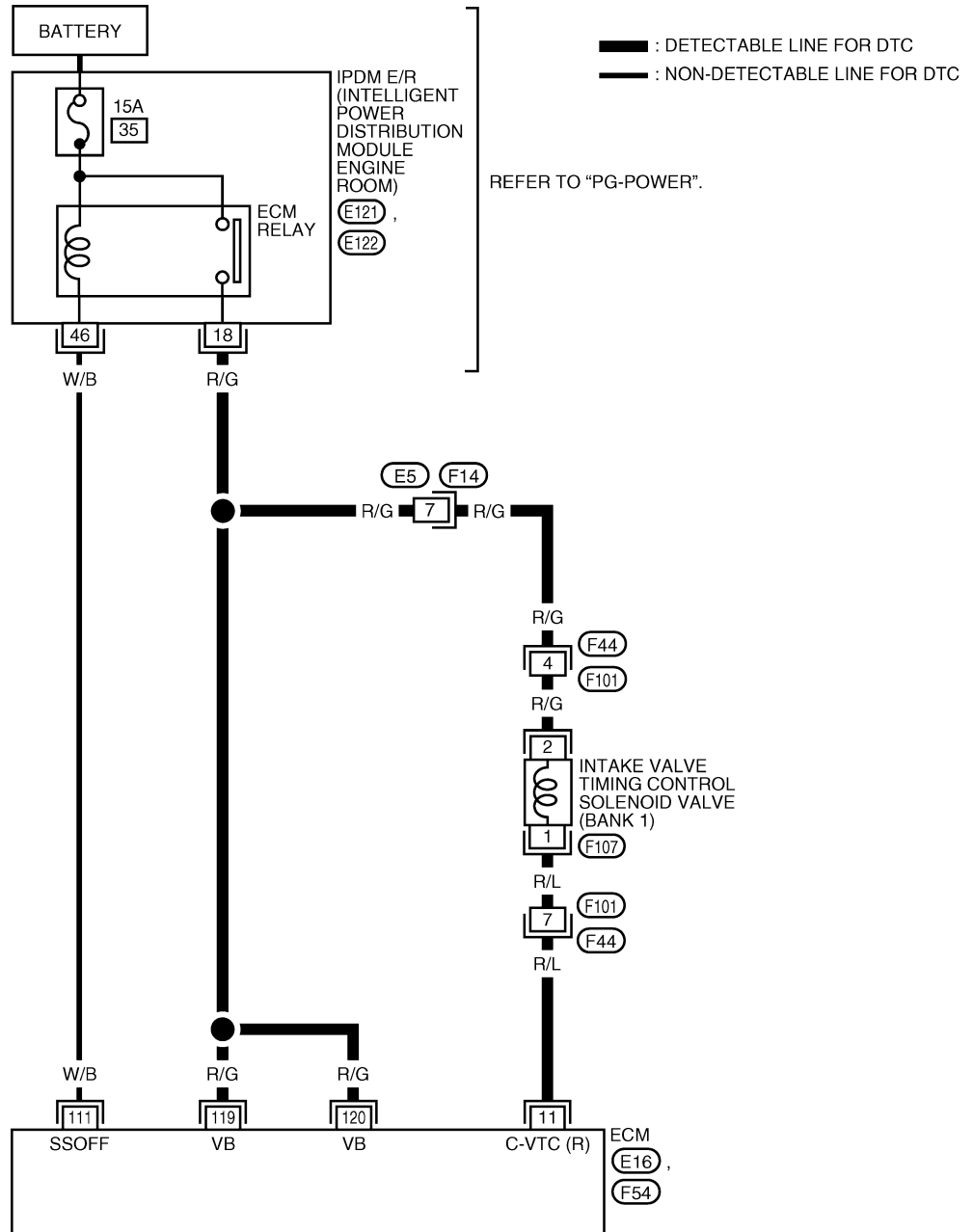

BBWA2548E

DTC P0075, P0081 IVT CONTROL SOLENOID VALVE

Specification data are reference values and are measured between each terminal and ground.
Pulse signal is measured by CONSULT-II.

CAUTION:

Do not use ECM ground terminals when measuring input/output voltage. Doing so may result in damage to the ECM's transistor. Use a ground other than ECM terminals, such as the ground.

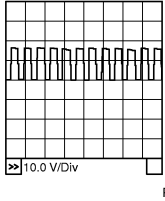
TER-MINAL NO.	WIRE COLOR	ITEM	CONDITION	DATA (DC Voltage)
11	R/L	Intake valve timing control solenoid valve (Bank 1)	[Engine is running] <ul style="list-style-type: none"> ● Warm-up condition ● Idle speed 	BATTERY VOLTAGE (11 - 14V)
			[Engine is running] <ul style="list-style-type: none"> ● Warm-up condition ● Engine speed: 2,000 rpm 	7 - 12V★ 
111	W/B	ECM relay (Self shut-off)	[Engine is running] [Ignition switch: OFF] <ul style="list-style-type: none"> ● For a few seconds after turning ignition switch OFF 	0 - 1.5V
			[Ignition switch: OFF] <ul style="list-style-type: none"> ● More than a few seconds after turning ignition switch OFF 	BATTERY VOLTAGE (11 - 14V)
119 120	R/G R/G	Power supply for ECM	[Ignition switch: ON]	BATTERY VOLTAGE (11 - 14V)

★: Average voltage for pulse signal (Actual pulse signal can be confirmed by oscilloscope.)

DTC P0075, P0081 IVT CONTROL SOLENOID VALVE

BANK 2

EC-IVCB2-01

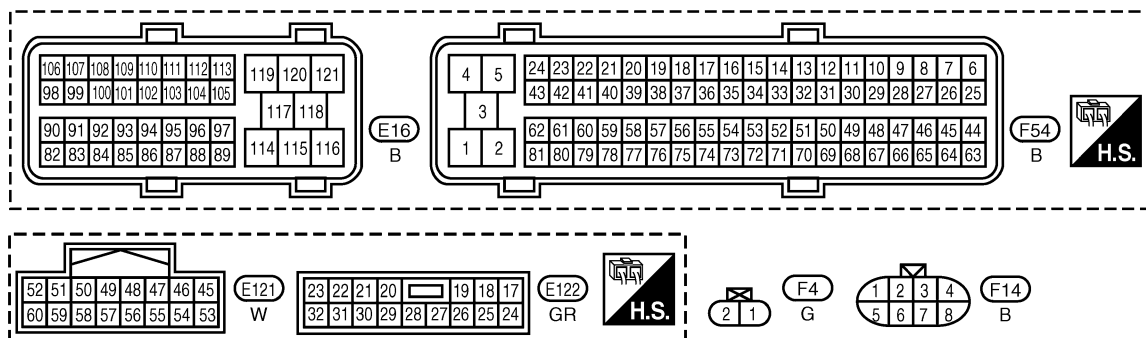
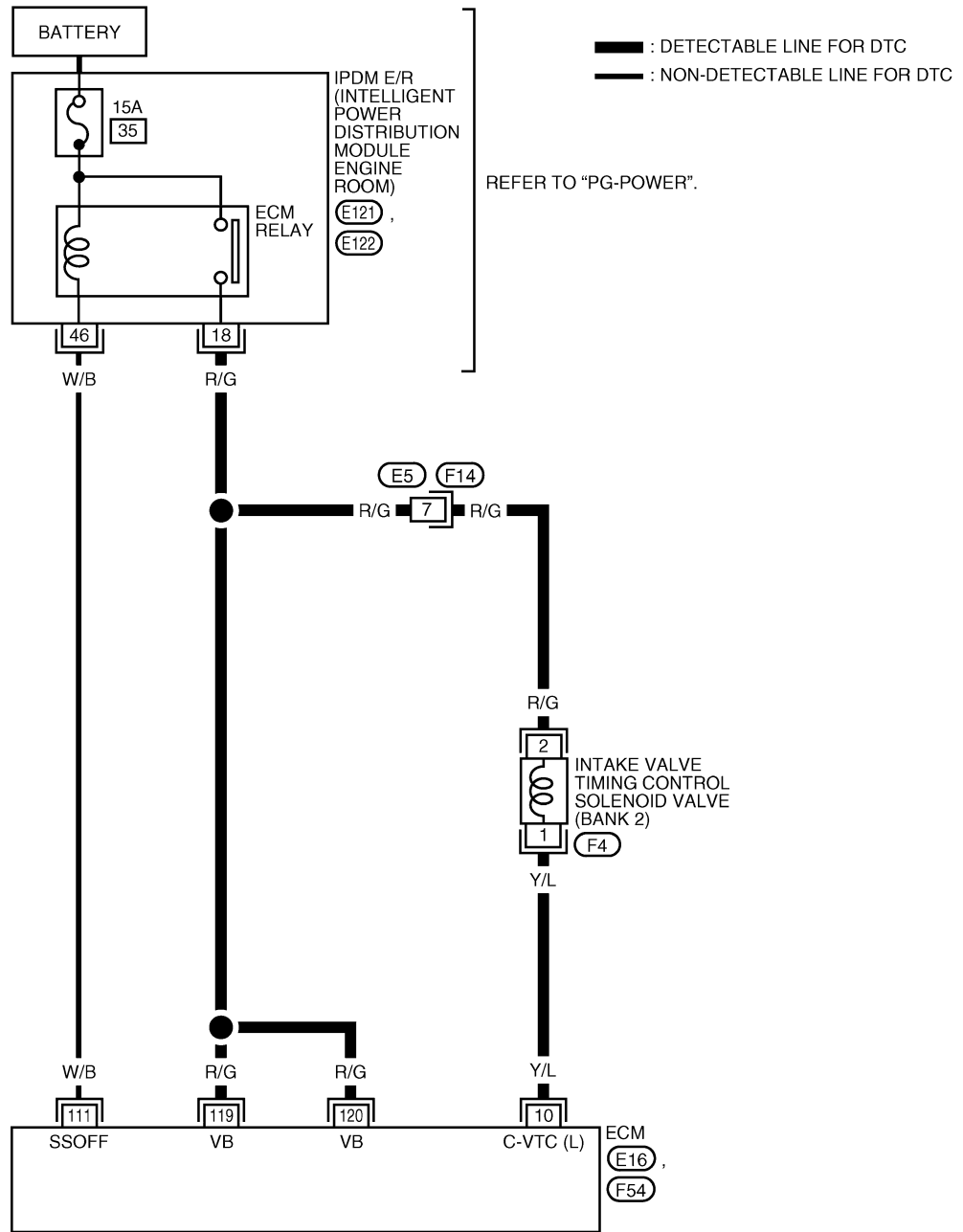

BBWA2549E

DTC P0075, P0081 IVT CONTROL SOLENOID VALVE

Specification data are reference values and are measured between each terminal and ground.
Pulse signal is measured by CONSULT-II.

CAUTION:

Do not use ECM ground terminals when measuring input/output voltage. Doing so may result in damage to the ECM's transistor. Use a ground other than ECM terminals, such as the ground.

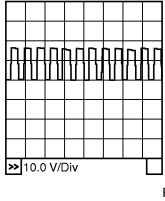
TER-MINAL NO.	WIRE COLOR	ITEM	CONDITION	DATA (DC Voltage)
10	Y/L	Intake valve timing control solenoid valve (Bank 2)	[Engine is running] <ul style="list-style-type: none"> ● Warm-up condition ● Idle speed 	BATTERY VOLTAGE (11 - 14V)
			[Engine is running] <ul style="list-style-type: none"> ● Warm-up condition ● Engine speed: 2,000 rpm 	7 - 12V★ 
111	W/B	ECM relay (Self shut-off)	[Engine is running] [Ignition switch: OFF] <ul style="list-style-type: none"> ● For a few seconds after turning ignition switch OFF 	0 - 1.5V
			[Ignition switch: OFF] <ul style="list-style-type: none"> ● More than a few seconds after turning ignition switch OFF 	BATTERY VOLTAGE (11 - 14V)
119 120	R/G R/G	Power supply for ECM	[Ignition switch: ON]	BATTERY VOLTAGE (11 - 14V)

★: Average voltage for pulse signal (Actual pulse signal can be confirmed by oscilloscope.)

DTC P0075, P0081 IVT CONTROL SOLENOID VALVE

UBS00P37

Diagnostic Procedure

1. CHECK INTAKE VALVE TIMING CONTROL SOLENOID VALVE POWER SUPPLY CIRCUIT

1. Turn ignition switch OFF.
2. Disconnect intake valve timing control solenoid valve harness connector.

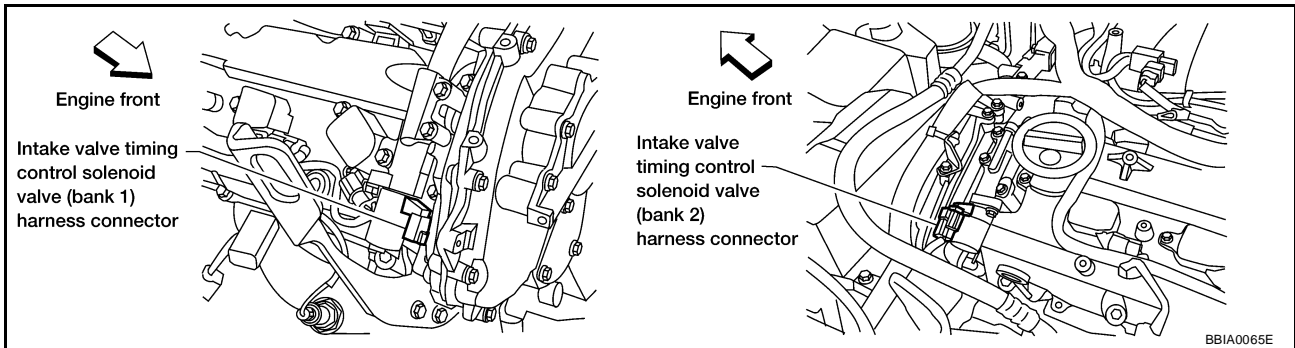

3. Turn ignition switch ON.
4. Check voltage between intake valve timing control solenoid valve terminal 2 and ground with CONSULT-II or tester.

Voltage: Battery voltage

OK or NG

- OK >> GO TO 3.
NG >> GO TO 2.

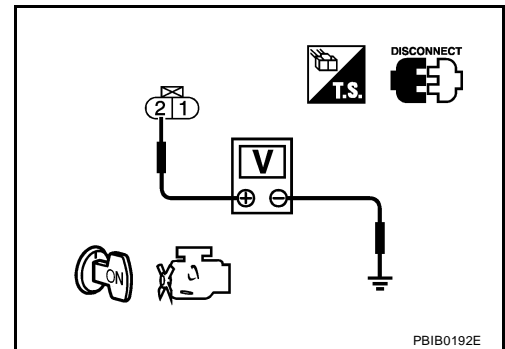

2. DETECT MALFUNCTIONING PART

Check the following.

- Harness connectors E5, F14
- Harness connectors F44, F101 (bank 1)
- Harness for open or short between intake valve timing control solenoid valve and IPDM E/R
- Harness for open or short between intake valve timing control solenoid valve and ECM

>> Repair harness or connectors.

3. CHECK INTAKE VALVE TIMING CONTROL SOLENOID VALVE OUTPUT SIGNAL CIRCUIT FOR OPEN AND SHORT

1. Turn ignition switch OFF.
2. Disconnect ECM harness connector.
3. Check harness continuity between ECM terminal 11 (bank 1) or 10 (bank 2) and intake valve timing control solenoid valve terminal 1. Refer to Wiring Diagram.

Continuity should exist.

4. Also check harness for short to ground and short to power.

OK or NG

- OK >> GO TO 5.
NG >> GO TO 4.

DTC P0075, P0081 IVT CONTROL SOLENOID VALVE

4. DETECT MALFUNCTIONING PART

Check the following.

- Harness connectors F44, F101 (bank 1)
- Harness for open and short between intake valve timing control solenoid valve and ECM

>> Repair open circuit or short to ground or short to power in harness or connectors.

5. CHECK INTAKE VALVE TIMING CONTROL SOLENOID VALVE

Refer to [EC-191, "Component Inspection"](#) .

OK or NG

- OK >> GO TO 6.
- NG >> Replace intake valve timing control solenoid valve.

6. CHECK INTERMITTENT INCIDENT

Refer to [EC-149, "TROUBLE DIAGNOSIS FOR INTERMITTENT INCIDENT"](#) .

>> INSPECTION END

Component Inspection INTAKE VALVE TIMING CONTROL SOLENOID VALVE

UBS00P38

1. Disconnect intake valve timing control solenoid valve harness connector.
2. Check resistance between intake valve timing control solenoid valve terminals as follows.

Terminals	Resistance
1 and 2	7.0 - 7.5Ω [at 20°C (68°F)]
1 or 2 and ground	∞Ω (Continuity should not exist)

If NG, replace intake valve timing control solenoid valve.
If OK, go to next step.

3. Remove intake valve timing control solenoid valve.
4. Provide 12V DC between intake valve timing control solenoid valve terminals and then interrupt it. Make sure that the plunger moves as shown in the figure.

CAUTION:

Do not apply 12V DC continuously for 5 seconds or more. Doing so may result in damage to the coil in intake valve timing control solenoid valve.

If NG, replace intake valve timing control solenoid valve.

NOTE:

Always replace O-ring when intake valve timing control solenoid valve is removed.

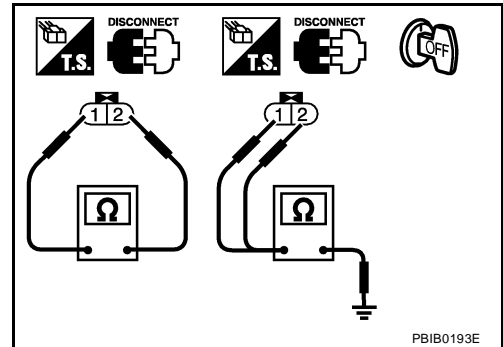

PBIB0193E

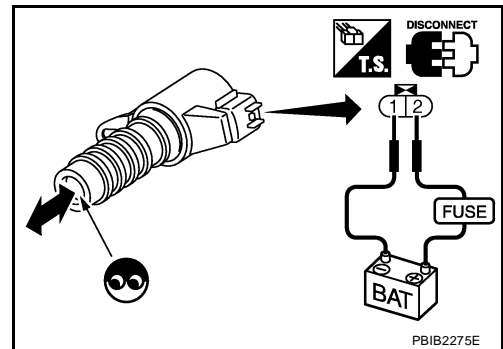

PBIB2275E

Removal and Installation INTAKE VALVE TIMING CONTROL SOLENOID VALVE

Refer to [EM-56, "TIMING CHAIN"](#) .

UBS00P39

DTC P0101 MAF SENSOR

DTC P0101 MAF SENSOR

PF2:22680

Component Description

UBS00P3A

The mass air flow sensor is placed in the stream of intake air. It measures the intake flow rate by measuring a part of the entire intake flow. The mass air flow sensor controls the temperature of the hot wire to a certain amount. The heat generated by the hot wire is reduced as the intake air flows around it. The more air, the greater the heat loss.

Therefore, the electric current supplied to hot wire is changed to maintain the temperature of the hot wire as air flow increases. The ECM detects the air flow by means of this current change.

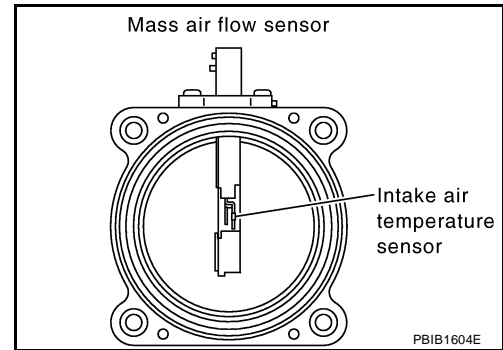

CONSULT-II Reference Value in Data Monitor Mode

UBS00P3B

Specification data are reference values.

MONITOR ITEM	CONDITION	SPECIFICATION
MAS A/F SE-B1	<ul style="list-style-type: none"> See EC-139, "TROUBLE DIAGNOSIS - SPECIFICATION VALUE". 	
CAL/LD VALUE	<ul style="list-style-type: none"> Engine: After warming up Shift lever: P or N Air conditioner switch: OFF No load 	Idle 5% - 35%
		2,500 rpm 5% - 35%
MASS AIRFLOW	<ul style="list-style-type: none"> Engine: After warming up Shift lever: P or N Air conditioner switch: OFF No load 	Idle 2.0 - 6.0 g-m/s
		2,500 rpm 7.0 - 20.0 g-m/s

On Board Diagnosis Logic

UBS00P3C

DTC No.	Trouble diagnosis name	DTC detecting condition	Possible cause
P0101 0101	Mass air flow sensor circuit range/performance	A) A high voltage from the sensor is sent to ECM under light load driving condition.	<ul style="list-style-type: none"> Harness or connectors (The sensor circuit is open or shorted.) Mass air flow sensor EVAP control system pressure sensor Intake air temperature sensor
		B) A low voltage from the sensor is sent to ECM under heavy load driving condition.	<ul style="list-style-type: none"> Harness or connectors (The sensor circuit is open or shorted.) Intake air leaks Mass air flow sensor EVAP control system pressure sensor Intake air temperature sensor

DTC P0101 MAF SENSOR

UBS00P3D

DTC Confirmation Procedure

Perform **PROCEDURE FOR MALFUNCTION A** first.

If the DTC cannot be confirmed, perform **PROCEDURE FOR MALFUNCTION B**.

NOTE:

If DTC Confirmation Procedure has been previously conducted, always turn ignition switch OFF and wait at least 10 seconds before conducting the next test.

PROCEDURE FOR MALFUNCTION A

NOTE:

If engine will not start or stops soon, wait at least 10 seconds with engine stopped (Ignition switch ON) instead of running engine at idle speed.

With CONSULT-II

1. Turn ignition switch ON.
2. Select "DATA MONITOR" mode with CONSULT-II.
3. Start engine and warm it up to normal operating temperature.
4. Run engine for at least 10 seconds at idle speed.
5. If 1st trip DTC is detected, go to [EC-196, "Diagnostic Procedure"](#)

DATA MONITOR	
MONITOR	NO DTC
ENG SPEED	XXX rpm
COOLAN TEMP/S	XXX °C

SEF174Y

With GST

Follow the procedure "With CONSULT-II" above.

PROCEDURE FOR MALFUNCTION B

CAUTION:

Always drive vehicle at a safe speed.

With CONSULT-II

1. Turn ignition switch ON.
2. Start engine and warm it up to normal operating temperature.
If engine cannot be started, go to [EC-196, "Diagnostic Procedure"](#).
3. Select "DATA MONITOR" mode with CONSULT-II.
4. Check the voltage of "MAS A/F SE-B1" with "DATA MONITOR".
5. Increases engine speed to about 4,000 rpm.
6. Monitor the linear voltage rise in response to engine speed increases.
If NG, go to [EC-196, "Diagnostic Procedure"](#).
If OK, go to following step.

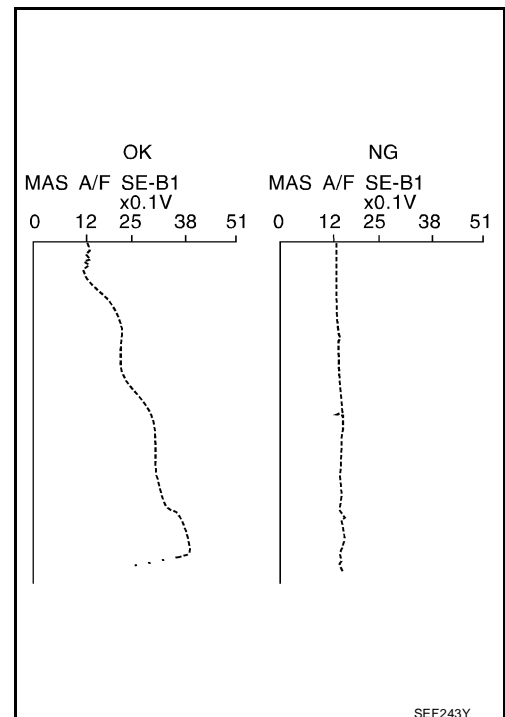

DTC P0101 MAF SENSOR

7. Maintain the following conditions for at least 10 consecutive seconds.

ENG SPEED	More than 2,000 rpm
THRTL SEN 1	More than 3V
THRTL SEN 2	More than 3V
Shift lever	Suitable position
Driving location	Driving vehicle uphill (Increased engine load) will help maintain the driving conditions required for this test.

DATA MONITOR	
MONITOR	NO DTC
ENG SPEED	XXX rpm
VHCL SPEED SE	XXX km/h
THRTL SEN 1	XXX V
THRTL SEN 2	XXX V

PBIB0199E

8. If 1st trip DTC is detected, go to [EC-196, "Diagnostic Procedure"](#)

Overall Function Check PROCEDURE FOR MALFUNCTION B

UBS00P3E

Use this procedure to check the overall function of the mass air flow sensor circuit. During this check, a 1st trip DTC might not be confirmed.

With GST

1. Start engine and warm it up to normal operating temperature.
2. Select Service \$01 with GST.
3. Check the mass air flow sensor signal with Service \$01.
4. Check for linear mass air flow sensor signal value rise in response to increases to about 4,000 rpm in engine speed.
5. If NG, go to [EC-196, "Diagnostic Procedure"](#).

CALC LOAD	20%
COOLANT TEMP	95°C
SHORT FT #1	2%
LONG FT #1	0%
SHORT FT #2	4%
LONG FT #2	0%
ENGINE SPD	2637RPM
VEHICLE SPD	0MPH
IGN ADVANCE	41.0°
INTAKE AIR	41°C
MAF	14.1gm/sec
THROTTLE POS	3%

SEF534P

DTC P0101 MAF SENSOR

UBS00P3F

Wiring Diagram

EC-MAFS-01

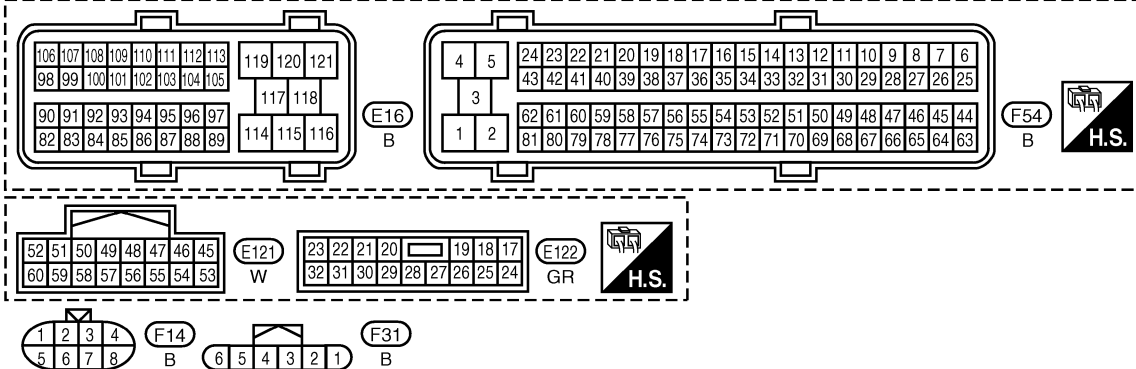
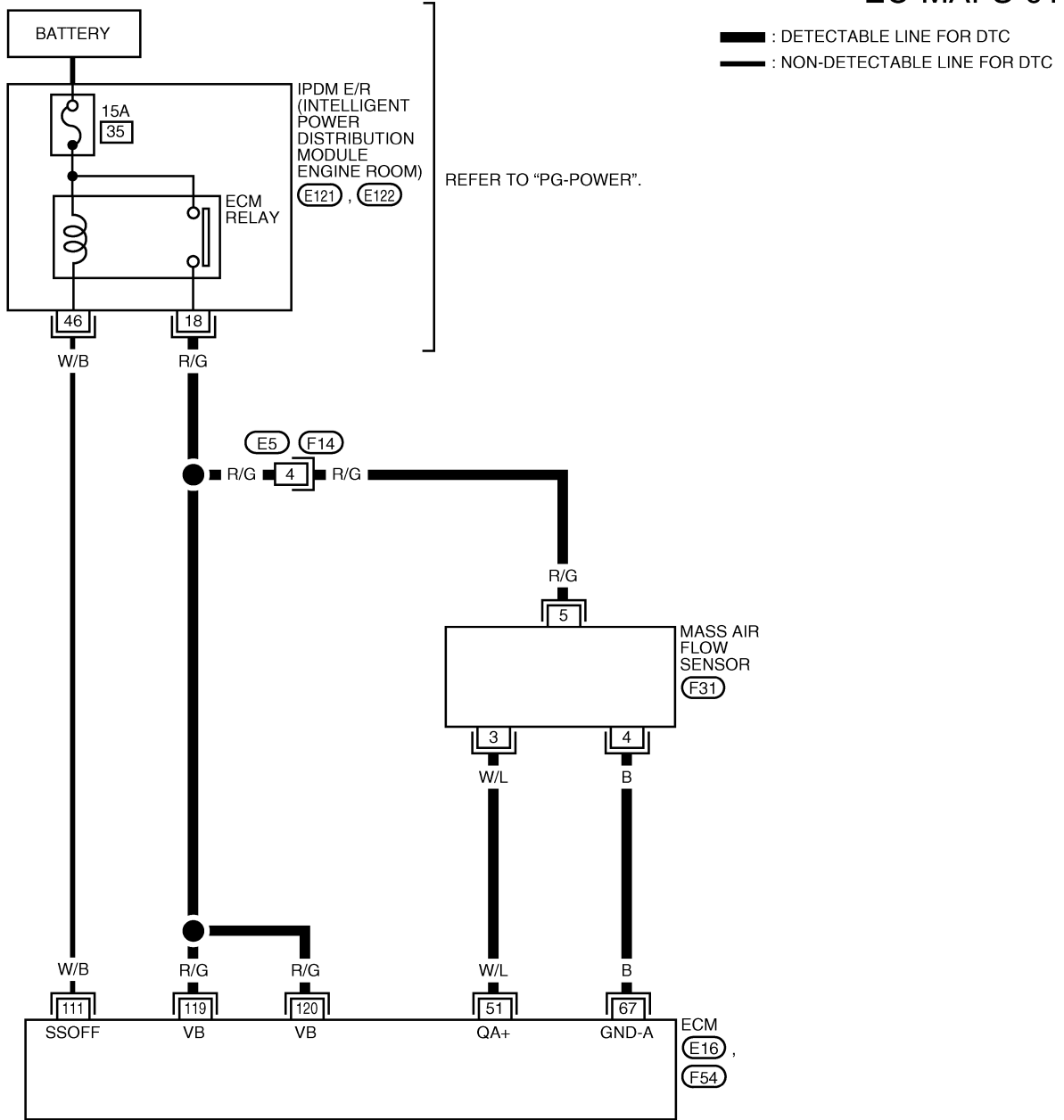

BBWA2511E

DTC P0101 MAF SENSOR

Specification data are reference values and are measured between each terminal and ground.

CAUTION:

Do not use ECM ground terminals when measuring input/output voltage. Doing so may result in damage to the ECM's transistor. Use a ground other than ECM terminals, such as the ground.

TER-MINAL NO.	WIRE COLOR	ITEM	CONDITION	DATA (DC Voltage)
51	W/L	Mass air flow sensor	[Engine is running] ● Warm-up condition ● Idle speed	1.0 - 1.3V
			[Engine is running] ● Warm-up condition ● Engine speed: 2,500 rpm	1.6 - 2.0V
67	B	Sensor ground	[Engine is running] ● Warm-up condition ● Idle speed	Approximately 0V
111	W/B	ECM relay (Self shut-off)	[Engine is running] [Ignition switch: OFF] ● For a few seconds after turning ignition switch OFF	0 - 1.5V
			[Ignition switch: OFF] ● More than a few seconds after turning ignition switch OFF	BATTERY VOLTAGE (11 - 14V)
119 120	R/G R/G	Power supply for ECM	[Ignition switch: ON]	BATTERY VOLTAGE (11 - 14V)

Diagnostic Procedure

UBS00P3G

1. INSPECTION START

Which malfunction (A or B) is duplicated?

A or B

- A >> GO TO 3.
- B >> GO TO 2.

2. CHECK INTAKE SYSTEM

Check the following for connection.

- Air duct
- Vacuum hoses
- Intake air passage between air duct and intake manifold

OK or NG

- OK >> GO TO 3.
- NG >> Reconnect the parts.

DTC P0101 MAF SENSOR

3. CHECK GROUND CONNECTIONS

1. Turn ignition switch OFF.
2. Loosen and retighten three ground screws on the body. Refer to [EC-158, "Ground Inspection"](#).

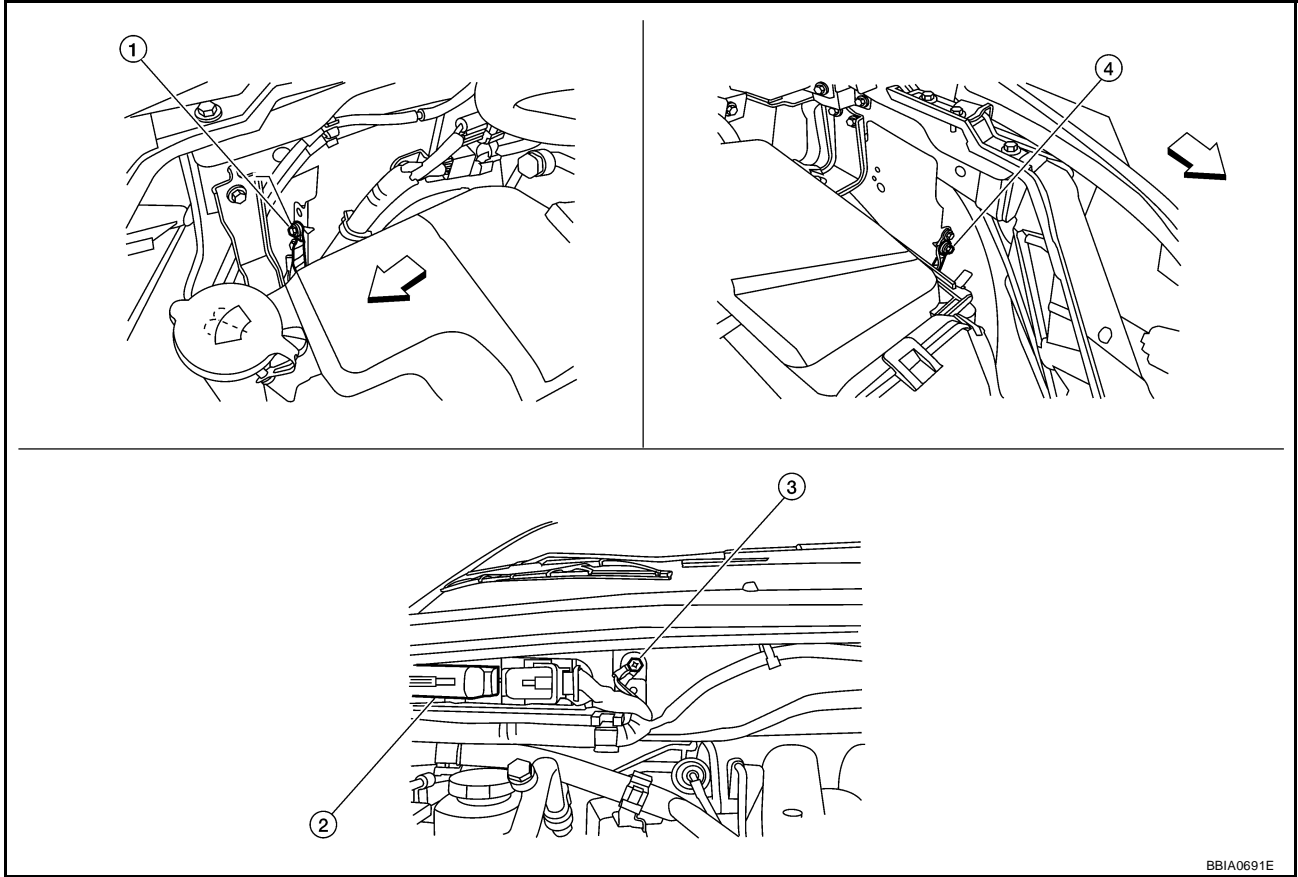

↔ Vehicle front

1. Body ground E24
4. Body ground E15

2. ECM

3. Body ground E9

OK or NG

OK >> GO TO 4.

NG >> Repair or replace ground connections.

DTC P0101 MAF SENSOR

4. CHECK MAF SENSOR POWER SUPPLY CIRCUIT

1. Disconnect mass air flow (MAF) sensor harness connector.
2. Turn ignition switch ON.

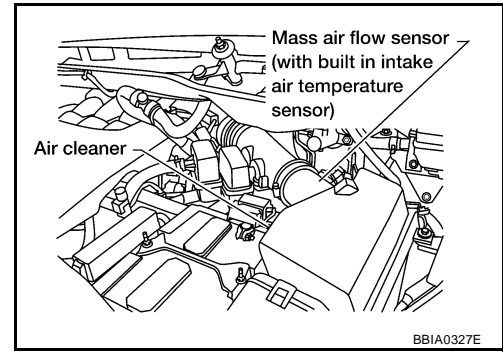

3. Check voltage between MAF sensor terminal 5 and ground with CONSULT-II or tester.

Voltage: Battery voltage

OK or NG

- OK >> GO TO 6.
NG >> GO TO 5.

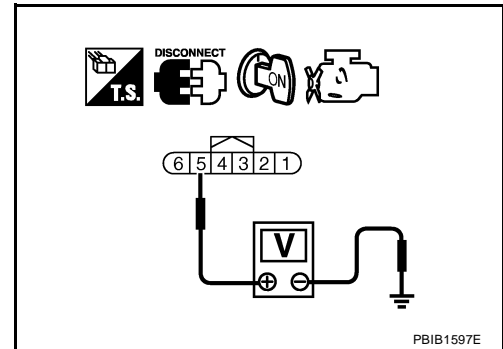

5. DETECT MALFUNCTIONING PART

Check the following.

- Harness connectors E5, F14
- Harness for open or short between mass air flow sensor and IPDM E/R
- Harness for open or short between mass air flow sensor and ECM

>> Repair harness or connectors.

6. CHECK MAF SENSOR GROUND CIRCUIT FOR OPEN AND SHORT

1. Turn ignition switch OFF.
2. Disconnect ECM harness connector.
3. Check harness continuity between MAF sensor terminal 4 and ECM terminal 67. Refer to Wiring Diagram.

Continuity should exist.

4. Also check harness for short to ground and short to power.

OK or NG

- OK >> GO TO 7.
NG >> Repair open circuit or short to ground or short to power in harness or connectors.

DTC P0101 MAF SENSOR

7. CHECK MAF SENSOR INPUT SIGNAL CIRCUIT FOR OPEN AND SHORT

1. Check harness continuity between MAF sensor terminal 3 and ECM terminal 51.
Refer to Wiring Diagram.

Continuity should exist.

2. Also check harness for short to ground and short to power.

OK or NG

OK >> GO TO 8.

NG >> Repair open circuit or short to ground or short to power in harness or connectors.

8. CHECK INTAKE AIR TEMPERATURE SENSOR

Refer to [EC-215, "Component Inspection"](#) .

OK or NG

OK >> GO TO 9.

NG >> Replace intake air temperature sensor.

9. CHECK EVAP CONTROL SYSTEM PRESSURE SENSOR

Refer to [EC-471, "Component Inspection"](#) .

OK or NG

OK >> GO TO 10.

NG >> Replace EVAP control system pressure sensor.

10. CHECK MASS AIR FLOW SENSOR

Refer to [EC-200, "Component Inspection"](#) .

OK or NG

OK >> GO TO 11.

NG >> Replace mass air flow sensor.

11. CHECK INTERMITTENT INCIDENT

Refer to [EC-149, "TROUBLE DIAGNOSIS FOR INTERMITTENT INCIDENT"](#) .

>> **INSPECTION END**

A

EC

C

D

E

F

G

H

I

J

K

L

M

DTC P0101 MAF SENSOR

UBS00P3H

Component Inspection MASS AIR FLOW SENSOR

With CONSULT-II

1. Reconnect all harness connectors disconnected.
2. Start engine and warm it up to normal operating temperature.
3. Connect CONSULT-II and select "DATA MONITOR" mode.
4. Select "MAS A/F SE-B1" and check indication under the following conditions.

Condition	MAS A/F SE-B1 (V)
Ignition switch ON (Engine stopped.)	Approx. 0.4
Idle (Engine is warmed-up to normal operating temperature.)	1.0 - 1.3
2,500 rpm (Engine is warmed-up to normal operating temperature.)	1.6 - 2.0
Idle to about 4,000 rpm	1.0 - 1.3 to Approx. 2.4*

*: Check for linear voltage rise in response to engine being increased to about 4,000 rpm.

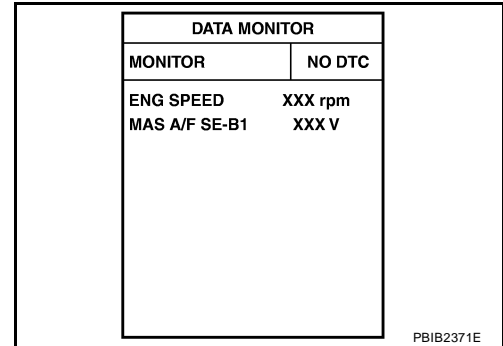

5. If the voltage is out of specification, proceed the following.
 - a. Check for the cause of uneven air flow through mass air flow sensor. Refer to following.
 - Crushed air ducts
 - Malfunctioning seal of air cleaner element
 - Uneven dirt of air cleaner element
 - Improper specification of intake air system parts
 - b. If NG, repair or replace malfunctioning part and perform step 2 to 4 again. If OK, go to next step.
6. Turn ignition switch OFF.
7. Disconnect mass air flow sensor harness connector and reconnect it again.
8. Perform step 2 to 4 again.
9. If NG, clean or replace mass air flow sensor.

Without CONSULT-II

1. Reconnect all harness connectors disconnected.
2. Start engine and warm it up to normal operating temperature.
3. Check voltage between ECM terminal 51 (Mass air flow sensor signal) and ground.

Condition	Voltage V
Ignition switch ON (Engine stopped.)	Approx. 0.4
Idle (Engine is warmed-up to normal operating temperature.)	1.0 - 1.3
2,500 rpm (Engine is warmed-up to normal operating temperature.)	1.6 - 2.0
Idle to about 4,000 rpm	1.0 - 1.3 to Approx. 2.4*

*: Check for linear voltage rise in response to engine being increased to about 4,000 rpm.

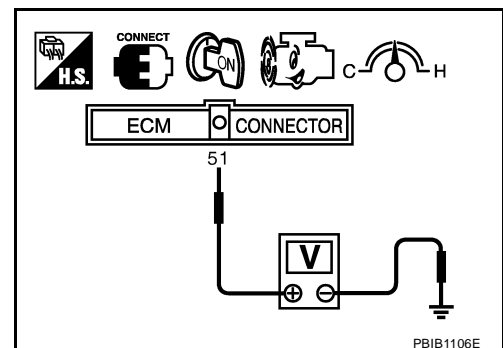

4. If the voltage is out of specification, proceed the following.
 - a. Check for the cause of uneven air flow through mass air flow sensor. Refer to following.
 - Crushed air ducts
 - Malfunctioning seal of air cleaner element
 - Uneven dirt of air cleaner element
 - Improper specification of intake air system parts

DTC P0101 MAF SENSOR

-
- b. If NG, repair or replace malfunctioning part and perform step 2 to 3 again.
If OK, go to next step.
 5. Turn ignition switch OFF.
 6. Disconnect mass air flow sensor harness connector and reconnect it again.
 7. Perform step 2 and 3 again.
 8. If NG, clean or replace mass air flow sensor.

Removal and Installation MASS AIR FLOW SENSOR

Refer to [EM-16, "AIR CLEANER AND AIR DUCT"](#) .

A

EC

UBS00P3I

C

D

E

F

G

H

I

J

K

L

M

DTC P0102, P0103 MAF SENSOR

DTC P0102, P0103 MAF SENSOR

PF2:22680

Component Description

UBS00P3J

The mass air flow sensor is placed in the stream of intake air. It measures the intake flow rate by measuring a part of the entire intake flow. The mass air flow sensor controls the temperature of the hot wire to a certain amount. The heat generated by the hot wire is reduced as the intake air flows around it. The more air, the greater the heat loss.

Therefore, the electric current supplied to hot wire is changed to maintain the temperature of the hot wire as air flow increases. The ECM detects the air flow by means of this current change.

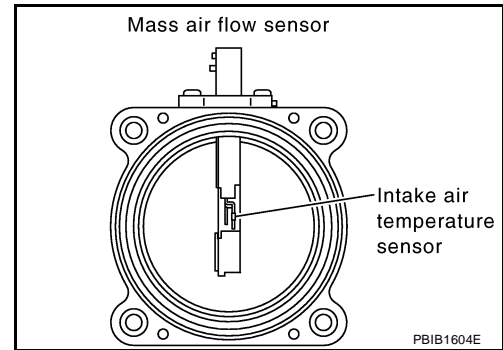

CONSULT-II Reference Value in Data Monitor Mode

UBS00P3K

Specification data are reference values.

MONITOR ITEM	CONDITION	SPECIFICATION
MAS A/F SE-B1	<ul style="list-style-type: none"> See EC-139, "TROUBLE DIAGNOSIS - SPECIFICATION VALUE". 	
CAL/LD VALUE	<ul style="list-style-type: none"> Engine: After warming up Shift lever: P or N Air conditioner switch: OFF No load 	Idle 5% - 35%
		2,500 rpm 5% - 35%
MASS AIRFLOW	<ul style="list-style-type: none"> Engine: After warming up Shift lever: P or N Air conditioner switch: OFF No load 	Idle 2.0 - 6.0 g-m/s
		2,500 rpm 7.0 - 20.0 g-m/s

On Board Diagnosis Logic

UBS00P3L

These self-diagnoses have the one trip detection logic.

DTC No.	Trouble diagnosis name	DTC detecting condition	Possible cause
P0102 0102	Mass air flow sensor circuit low input	An excessively low voltage from the sensor is sent to ECM.	<ul style="list-style-type: none"> Harness or connectors (The sensor circuit is open or shorted.) Intake air leaks Mass air flow sensor
P0103 0103	Mass air flow sensor circuit high input	An excessively high voltage from the sensor is sent to ECM.	<ul style="list-style-type: none"> Harness or connectors (The sensor circuit is open or shorted.) Mass air flow sensor

FAIL-SAFE MODE

When the malfunction is detected, the ECM enters fail-safe mode and the MIL lights up.

Detected items	Engine operating condition in fail-safe mode
Mass air flow sensor circuit	Engine speed will not rise more than 2,400 rpm due to the fuel cut.

DTC P0102, P0103 MAF SENSOR

UBS00P3M

DTC Confirmation Procedure

NOTE:

If DTC Confirmation Procedure has been previously conducted, always turn ignition switch OFF and wait at least 10 seconds before conducting the next test.

PROCEDURE FOR DTC P0102

With CONSULT-II

1. Turn ignition switch ON.
2. Select "DATA MONITOR" mode with CONSULT-II.
3. Start engine and wait at least 5 seconds.
4. If DTC is detected, go to [EC-205, "Diagnostic Procedure"](#) .

DATA MONITOR	
MONITOR	NO DTC
ENG SPEED	XXX rpm

SEF058Y

With GST

Follow the procedure "With CONSULT-II" above.

PROCEDURE FOR DTC P0103

With CONSULT-II

1. Turn ignition switch ON.
2. Select "DATA MONITOR" mode with CONSULT-II.
3. Wait at least 5 seconds.
4. If DTC is detected, go to [EC-205, "Diagnostic Procedure"](#) .
If DTC is not detected, go to next step.
5. Start engine and wait at least 5 seconds.
6. If DTC is detected, go to [EC-205, "Diagnostic Procedure"](#) .

DATA MONITOR	
MONITOR	NO DTC
ENG SPEED	XXX rpm

SEF058Y

With GST

Follow the procedure "With CONSULT-II" above.

DTC P0102, P0103 MAF SENSOR

UBS00P3N

Wiring Diagram

EC-MAFS-01

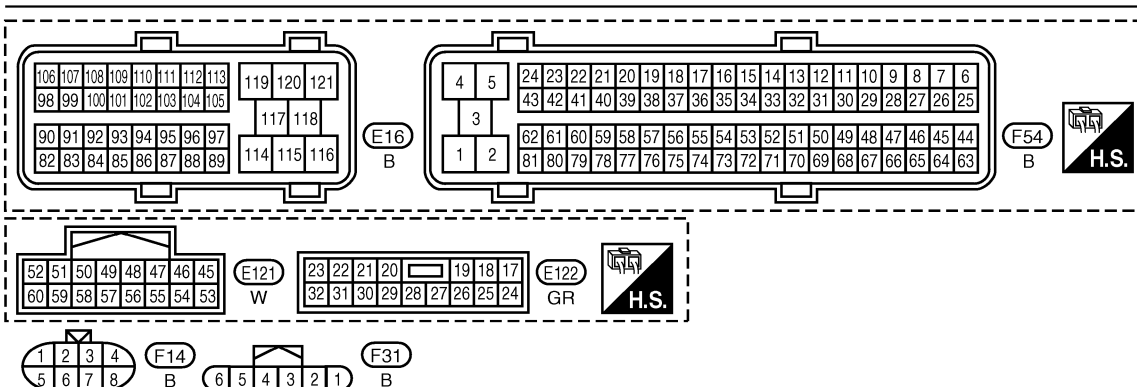
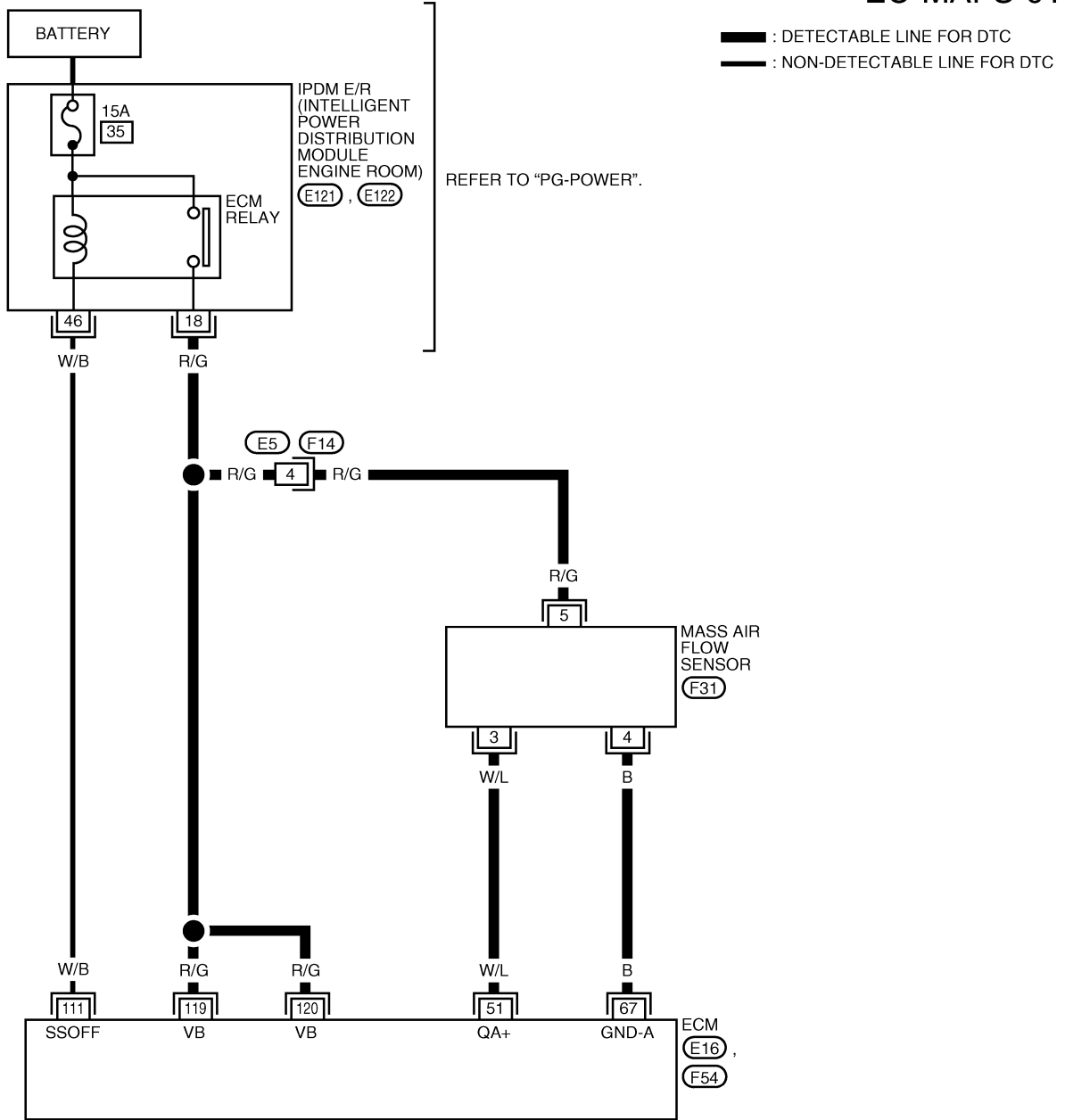

BBWA2511E

DTC P0102, P0103 MAF SENSOR

Specification data are reference values and are measured between each terminal and ground.

CAUTION:

Do not use ECM ground terminals when measuring input/output voltage. Doing so may result in damage to the ECM's transistor. Use a ground other than ECM terminals, such as the ground.

TER-MINAL NO.	WIRE COLOR	ITEM	CONDITION	DATA (DC Voltage)
51	W/L	Mass air flow sensor	[Engine is running] ● Warm-up condition ● Idle speed	1.0 - 1.3V
			[Engine is running] ● Warm-up condition ● Engine speed: 2,500 rpm	1.6 - 2.0V
67	B	Sensor ground	[Engine is running] ● Warm-up condition ● Idle speed	Approximately 0V
111	W/B	ECM relay (Self shut-off)	[Engine is running] [Ignition switch: OFF] ● For a few seconds after turning ignition switch OFF	0 - 1.5V
			[Ignition switch: OFF] ● More than a few seconds after turning ignition switch OFF	BATTERY VOLTAGE (11 - 14V)
119 120	R/G R/G	Power supply for ECM	[Ignition switch: ON]	BATTERY VOLTAGE (11 - 14V)

Diagnostic Procedure

UBS00P30

1. INSPECTION START

Which malfunction (P0102 or P0103) is duplicated?

P0102 or P0103

P0102 >> GO TO 2.

P0103 >> GO TO 3.

2. CHECK INTAKE SYSTEM

Check the following for connection.

- Air duct
- Vacuum hoses
- Intake air passage between air duct and intake manifold

OK or NG

OK >> GO TO 3.

NG >> Reconnect the parts.

DTC P0102, P0103 MAF SENSOR

3. CHECK GROUND CONNECTIONS

1. Turn ignition switch OFF.
2. Loosen and retighten three ground screws on the body. Refer to [EC-158, "Ground Inspection"](#).

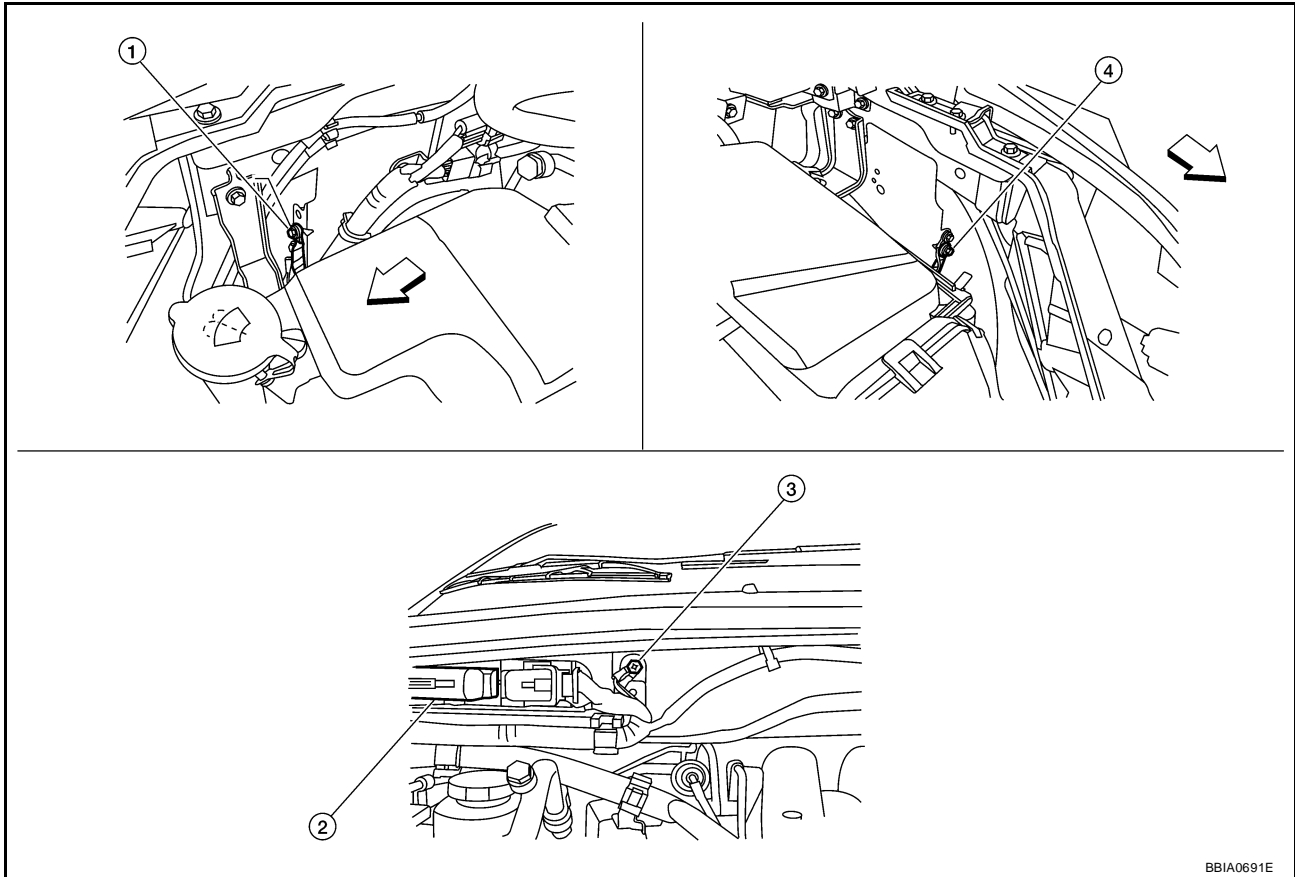

↔ Vehicle front

1. Body ground E24

2. ECM

3. Body ground E9

4. Body ground E15

OK or NG

OK >> GO TO 4.

NG >> Repair or replace ground connections.

BBIA0691E

DTC P0102, P0103 MAF SENSOR

4. CHECK MAF SENSOR POWER SUPPLY CIRCUIT

1. Disconnect mass air flow (MAF) sensor harness connector.
2. Turn ignition switch ON.

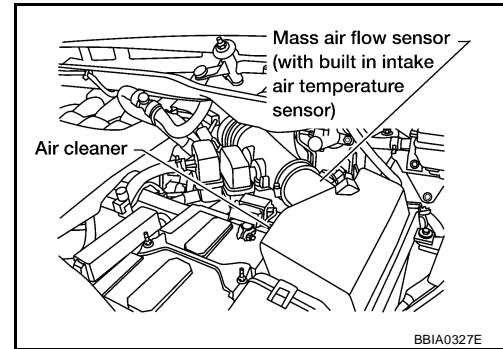

3. Check voltage between MAF sensor terminal 5 and ground with CONSULT-II or tester.

Voltage: Battery voltage

OK or NG

- OK >> GO TO 6.
- NG >> GO TO 5.

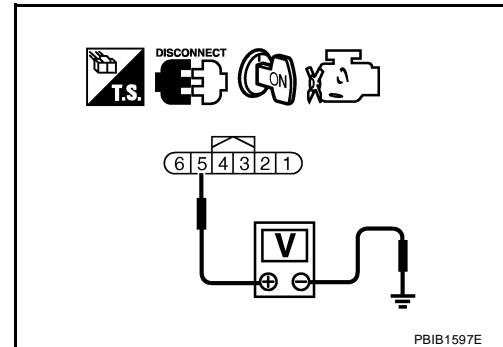

5. DETECT MALFUNCTIONING PART

Check the following.

- Harness connectors E5, F14
- Harness for open or short between mass air flow sensor and IPDM E/R
- Harness for open or short between mass air flow sensor and ECM

>> Repair harness or connectors.

6. CHECK MAF SENSOR GROUND CIRCUIT FOR OPEN AND SHORT

1. Turn ignition switch OFF.
2. Disconnect ECM harness connector.
3. Check harness continuity between MAF sensor terminal 4 and ECM terminal 67.
Refer to Wiring Diagram.

Continuity should exist.

4. Also check harness for short to ground and short to power.

OK or NG

- OK >> GO TO 7.
- NG >> Repair open circuit or short to ground or short to power in harness or connectors.

DTC P0102, P0103 MAF SENSOR

7. CHECK MAF SENSOR INPUT SIGNAL CIRCUIT FOR OPEN AND SHORT

1. Check harness continuity between MAF sensor terminal 3 and ECM terminal 51.
Refer to Wiring Diagram.

Continuity should exist.

2. Also check harness for short to ground and short to power.

OK or NG

OK >> GO TO 8.

NG >> Repair open circuit or short to ground or short to power in harness or connectors.

8. CHECK MASS AIR FLOW SENSOR

Refer to [EC-209, "Component Inspection"](#) .

OK or NG

OK >> GO TO 9.

NG >> Replace mass air flow sensor.

9. CHECK INTERMITTENT INCIDENT

Refer to [EC-149, "TROUBLE DIAGNOSIS FOR INTERMITTENT INCIDENT"](#) .

>> INSPECTION END

DTC P0102, P0103 MAF SENSOR

UBS00P3P

Component Inspection MASS AIR FLOW SENSOR

With CONSULT-II

1. Reconnect all harness connectors disconnected.
2. Start engine and warm it up to normal operating temperature.
3. Connect CONSULT-II and select "DATA MONITOR" mode.
4. Select "MAS A/F SE-B1" and check indication under the following conditions.

Condition	MAS A/F SE-B1 (V)
Ignition switch ON (Engine stopped.)	Approx. 0.4
Idle (Engine is warmed-up to normal operating temperature.)	1.0 - 1.3
2,500 rpm (Engine is warmed-up to normal operating temperature.)	1.6 - 2.0
Idle to about 4,000 rpm	1.0 - 1.3 to Approx. 2.4*

*: Check for linear voltage rise in response to engine being increased to about 4,000 rpm.

5. If the voltage is out of specification, proceed the following.
 - a. Check for the cause of uneven air flow through mass air flow sensor. Refer to following.
 - Crushed air ducts
 - Malfunctioning seal of air cleaner element
 - Uneven dirt of air cleaner element
 - Improper specification of intake air system parts
 - b. If NG, repair or replace malfunctioning part and perform step 2 to 4 again. If OK, go to next step.
6. Turn ignition switch OFF.
7. Disconnect mass air flow sensor harness connector and reconnect it again.
8. Perform step 2 to 4 again.
9. If NG, clean or replace mass air flow sensor.

Without CONSULT-II

1. Reconnect all harness connectors disconnected.
2. Start engine and warm it up to normal operating temperature.
3. Check voltage between ECM terminal 51 (Mass air flow sensor signal) and ground.

Condition	Voltage V
Ignition switch ON (Engine stopped.)	Approx. 0.4
Idle (Engine is warmed-up to normal operating temperature.)	1.0 - 1.3
2,500 rpm (Engine is warmed-up to normal operating temperature.)	1.6 - 2.0
Idle to about 4,000 rpm	1.0 - 1.3 to Approx. 2.4*

*: Check for linear voltage rise in response to engine being increased to about 4,000 rpm.

4. If the voltage is out of specification, proceed the following.
 - a. Check for the cause of uneven air flow through mass air flow sensor. Refer to following.
 - Crushed air ducts
 - Malfunctioning seal of air cleaner element
 - Uneven dirt of air cleaner element
 - Improper specification of intake air system parts

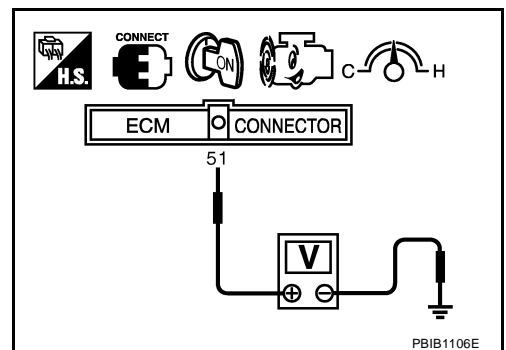
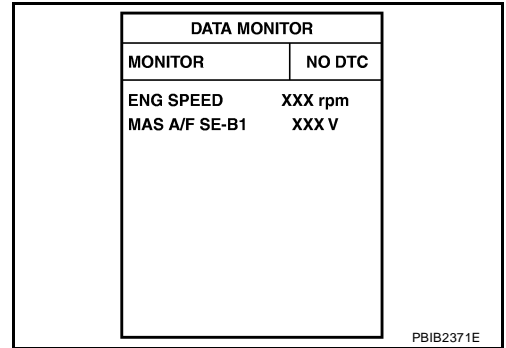

DTC P0102, P0103 MAF SENSOR

- b. If NG, repair or replace malfunctioning part and perform step 2 to 3 again.
If OK, go to next step.
5. Turn ignition switch OFF.
6. Disconnect mass air flow sensor harness connector and reconnect it again.
7. Perform step 2 and 3 again.
8. If NG, clean or replace mass air flow sensor.

Removal and Installation **MASS AIR FLOW SENSOR**

UBS00P3Q

Refer to [EM-16, "AIR CLEANER AND AIR DUCT"](#) .

DTC P0112, P0113 IAT SENSOR

PF0:22630

DTC P0112, P0113 IAT SENSOR

Component Description

UBS00P3R

The intake air temperature sensor is built-into mass air flow sensor. The sensor detects intake air temperature and transmits a signal to the ECM.

The temperature sensing unit uses a thermistor which is sensitive to the change in temperature. Electrical resistance of the thermistor decreases in response to the temperature rise.

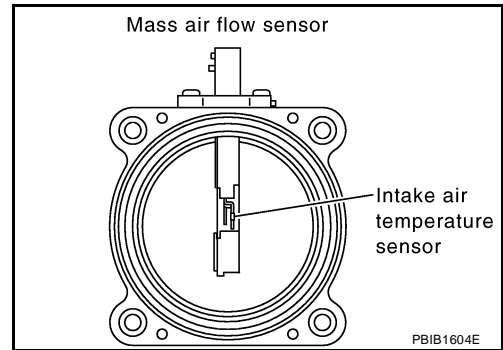

<Reference data>

Intake air temperature °C (°F)	Voltage* V	Resistance kΩ
25 (77)	3.32	1.800 - 2.200
80 (176)	1.23	0.283 - 0.359

*: This data is reference value and is measured between ECM terminal 34 (Intake air temperature sensor) and ground.

CAUTION:

Do not use ECM ground terminals when measuring input/output voltage. Doing so may result in damage to the ECM's transistor. Use a ground other than ECM terminals, such as the ground.

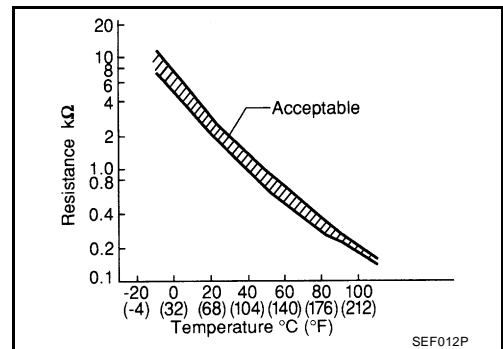

On Board Diagnosis Logic

UBS00P3S

DTC No.	Trouble diagnosis name	DTC detecting condition	Possible cause
P0112 0112	Intake air temperature sensor circuit low input	An excessively low voltage from the sensor is sent to ECM.	<ul style="list-style-type: none"> ● Harness or connectors (The sensor circuit is open or shorted.) ● Intake air temperature sensor
P0113 0113	Intake air temperature sensor circuit high input	An excessively high voltage from the sensor is sent to ECM.	

DTC Confirmation Procedure

UBS00P3T

NOTE:

If DTC Confirmation Procedure has been previously conducted, always turn ignition switch OFF and wait at least 10 seconds before conducting the next test.

WITH CONSULT-II

1. Turn ignition switch ON.
2. Select "DATA MONITOR" mode with CONSULT-II.
3. Wait at least 5 seconds.
4. If 1st trip DTC is detected, go to [EC-213, "Diagnostic Procedure"](#)

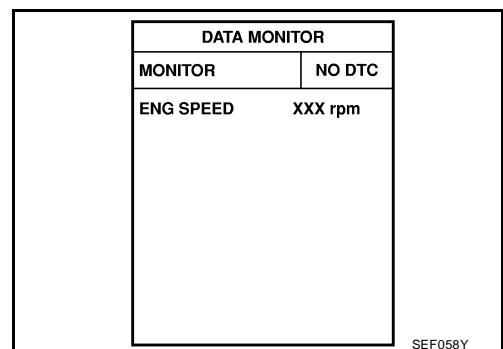

WITH GST

Follow the procedure "WITH CONSULT-II" above.

DTC P0112, P0113 IAT SENSOR

Wiring Diagram

UBS00P3U

EC-IATS-01

: DETECTABLE LINE FOR DTC
 : NON-DETECTABLE LINE FOR DTC

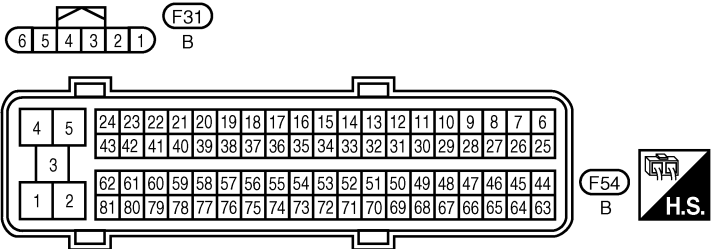
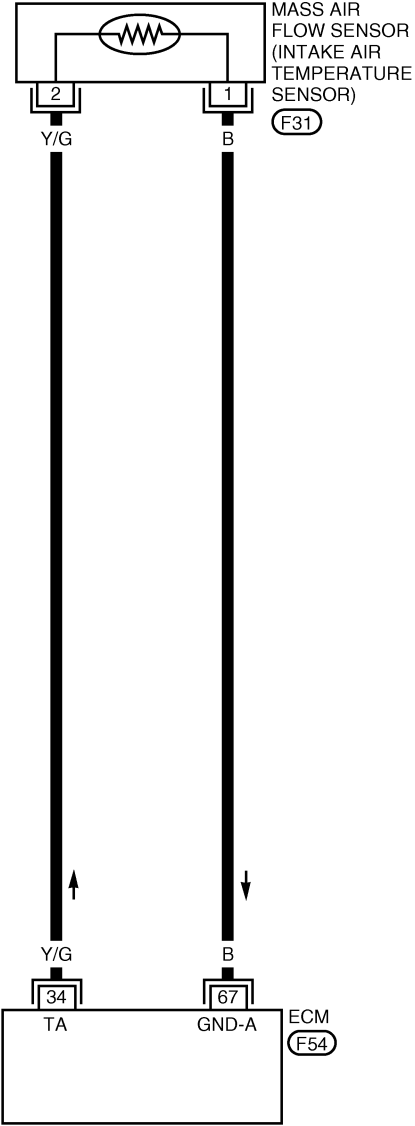

BBWA2512E

DTC P0112, P0113 IAT SENSOR

UBS00P3V

Diagnostic Procedure

1. CHECK GROUND CONNECTIONS

1. Turn ignition switch OFF.
2. Loosen and retighten three ground screws on the body. Refer to [EC-158, "Ground Inspection"](#).

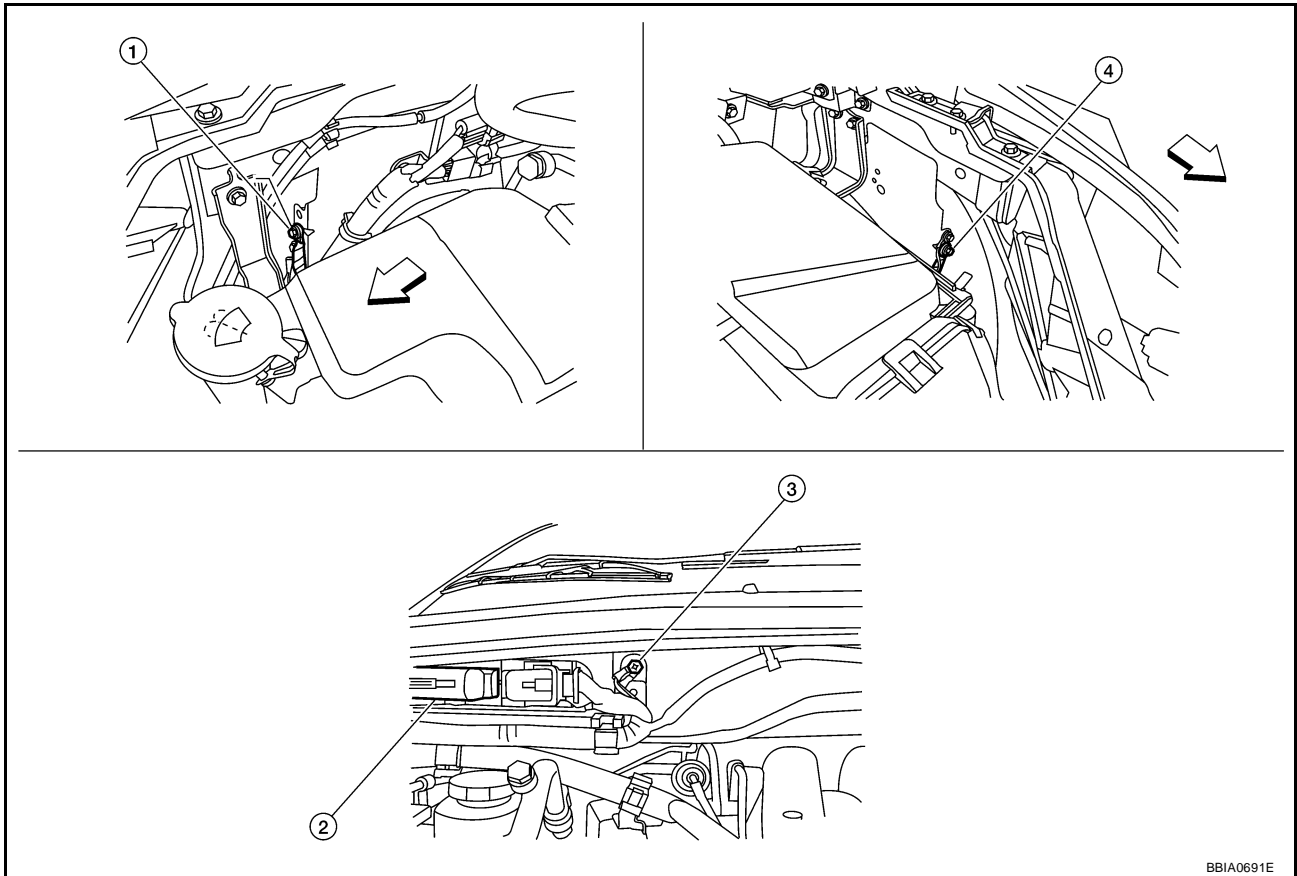

↔ Vehicle front

1. Body ground E24

2. ECM

3. Body ground E9

4. Body ground E15

OK or NG

OK >> GO TO 2.

NG >> Repair or replace ground connections.

DTC P0112, P0113 IAT SENSOR

2. CHECK INTAKE AIR TEMPERATURE SENSOR POWER SUPPLY CIRCUIT

1. Disconnect mass air flow sensor (intake air temperature sensor is built-into) harness connector.
2. Turn ignition switch ON.

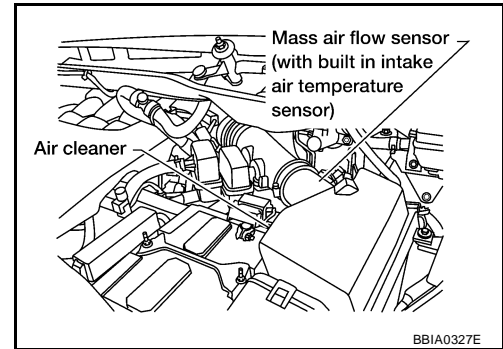

3. Check voltage between mass air flow sensor terminal 2 and ground.

Voltage: Approximately 5V

OK or NG

- OK >> GO TO 3.
NG >> Repair harness or connectors.

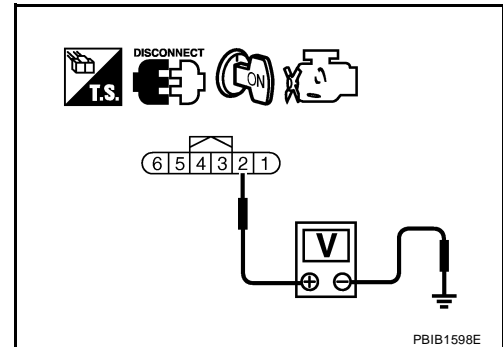

3. CHECK INTAKE AIR TEMPERATURE SENSOR GROUND CIRCUIT FOR OPEN AND SHORT

1. Turn ignition switch OFF.
2. Disconnect ECM harness connector.
3. Check harness continuity between mass air flow sensor terminal 1 and ECM terminal 67. Refer to Wiring Diagram.

Continuity should exist.

4. Also check harness for short to ground and short to power.

OK or NG

- OK >> GO TO 4.
NG >> Repair open circuit or short to ground or short to power in harness or connectors.

4. CHECK INTAKE AIR TEMPERATURE SENSOR

Refer to [EC-215, "Component Inspection"](#) .

OK or NG

- OK >> GO TO 5.
NG >> Replace mass air flow sensor (with intake air temperature sensor).

5. CHECK INTERMITTENT INCIDENT

Refer to [EC-149, "TROUBLE DIAGNOSIS FOR INTERMITTENT INCIDENT"](#) .

>> INSPECTION END

DTC P0112, P0113 IAT SENSOR

Component Inspection INTAKE AIR TEMPERATURE SENSOR

UBS00P3W

1. Check resistance between mass air flow sensor terminals 1 and 2 under the following conditions.

Intake air temperature °C (°F)	Resistance kΩ
25 (77)	1.800 - 2.200

2. If NG, replace mass air flow sensor (with intake air temperature sensor).

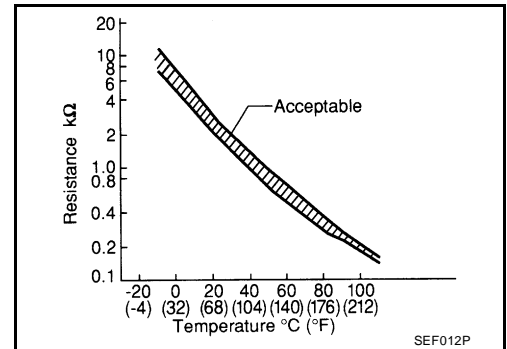
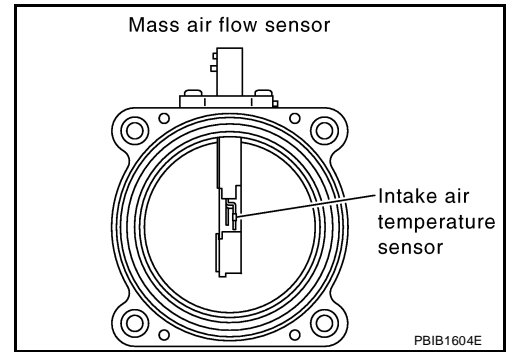

Removal and Installation MASS AIR FLOW SENSOR

UBS00P3X

Refer to [EM-16, "AIR CLEANER AND AIR DUCT"](#) .

A
EC
C
D
E
F
G
H
I
J
K
L
M

DTC P0117, P0118 ECT SENSOR

PF2:22630

DTC P0117, P0118 ECT SENSOR

Component Description

UBS00P3Y

The engine coolant temperature sensor is used to detect the engine coolant temperature. The sensor modifies a voltage signal from the ECM. The modified signal returns to the ECM as the engine coolant temperature input. The sensor uses a thermistor which is sensitive to the change in temperature. The electrical resistance of the thermistor decreases as temperature increases.

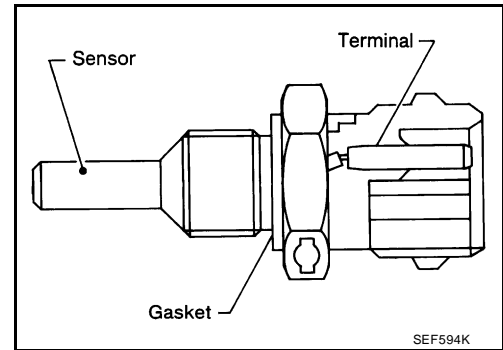

<Reference data>

Engine coolant temperature °C (°F)	Voltage* V	Resistance kΩ
-10 (14)	4.4	7.0 - 11.4
20 (68)	3.5	2.1 - 2.9
50 (122)	2.2	0.68 - 1.00
90 (194)	0.9	0.236 - 0.260

*: This data is reference value and is measured between ECM terminal 73 (Engine coolant temperature sensor) and ground.

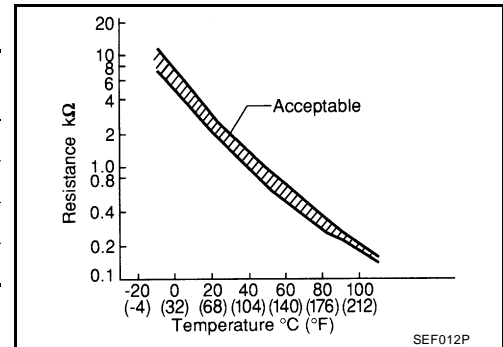

CAUTION:

Do not use ECM ground terminals when measuring input/output voltage. Doing so may result in damage to the ECM's transistor. Use a ground other than ECM terminals, such as the ground.

On Board Diagnosis Logic

UBS00P3Z

These self-diagnoses have the one trip detection logic.

DTC No.	Trouble Diagnosis Name	DTC Detecting Condition	Possible Cause
P0117 0117	Engine coolant temperature sensor circuit low input	An excessively low voltage from the sensor is sent to ECM.	<ul style="list-style-type: none"> ● Harness or connectors (The sensor circuit is open or shorted.) ● Engine coolant temperature sensor
P0118 0118	Engine coolant temperature sensor circuit high input	An excessively high voltage from the sensor is sent to ECM.	

FAIL-SAFE MODE

When the malfunction is detected, the ECM enters fail-safe mode and the MIL lights up.

Detected items	Engine operating condition in fail-safe mode	
Engine coolant temperature sensor circuit	Engine coolant temperature will be determined by ECM based on the time after turning ignition switch ON or START. CONSULT-II displays the engine coolant temperature decided by ECM.	
	Condition	Engine coolant temperature decided (CONSULT-II display)
	Just as ignition switch is turned ON or START	40°C (104°F)
	More than approx. 4 minutes after ignition ON or START	80°C (176°F)
	Except as shown above	40 - 80°C (104 - 176°F) (Depends on the time)
When the fail-safe system for engine coolant temperature sensor is activated, the cooling fan operates while engine is running.		

DTC P0117, P0118 ECT SENSOR

UBS00P40

DTC Confirmation Procedure

NOTE:

If DTC Confirmation Procedure has been previously conducted, always turn ignition switch OFF and wait at least 10 seconds before conducting the next test.

WITH CONSULT-II

1. Turn ignition switch ON.
2. Select "DATA MONITOR" mode with CONSULT-II.
3. Wait at least 5 seconds.
4. If DTC is detected, go to [EC-219, "Diagnostic Procedure"](#) .

DATA MONITOR	
MONITOR	NO DTC
ENG SPEED	XXX rpm

SEF058Y

WITH GST

Follow the procedure "WITH CONSULT-II" above.

A

EC

C

D

E

F

G

H

I

J

K

L

M

DTC P0117, P0118 ECT SENSOR

UBS00P41

Wiring Diagram

EC-ECTS-01

: DETECTABLE LINE FOR DTC
 : NON-DETECTABLE LINE FOR DTC

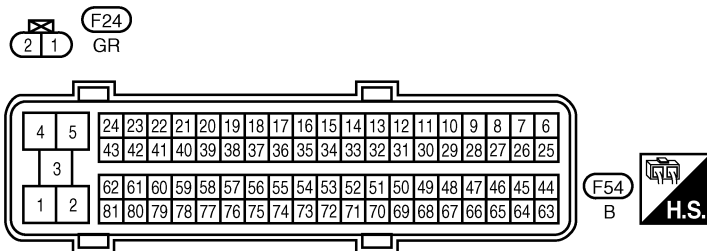
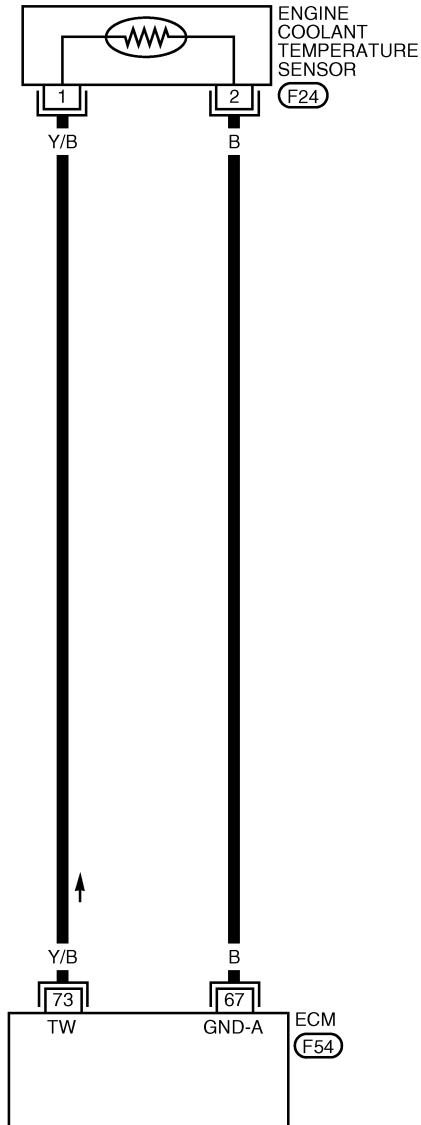

BBWA2513E

DTC P0117, P0118 ECT SENSOR

UBS00P42

Diagnostic Procedure

1. CHECK GROUND CONNECTIONS

1. Turn ignition switch OFF.
2. Loosen and retighten three ground screws on the body. Refer to [EC-158, "Ground Inspection"](#).

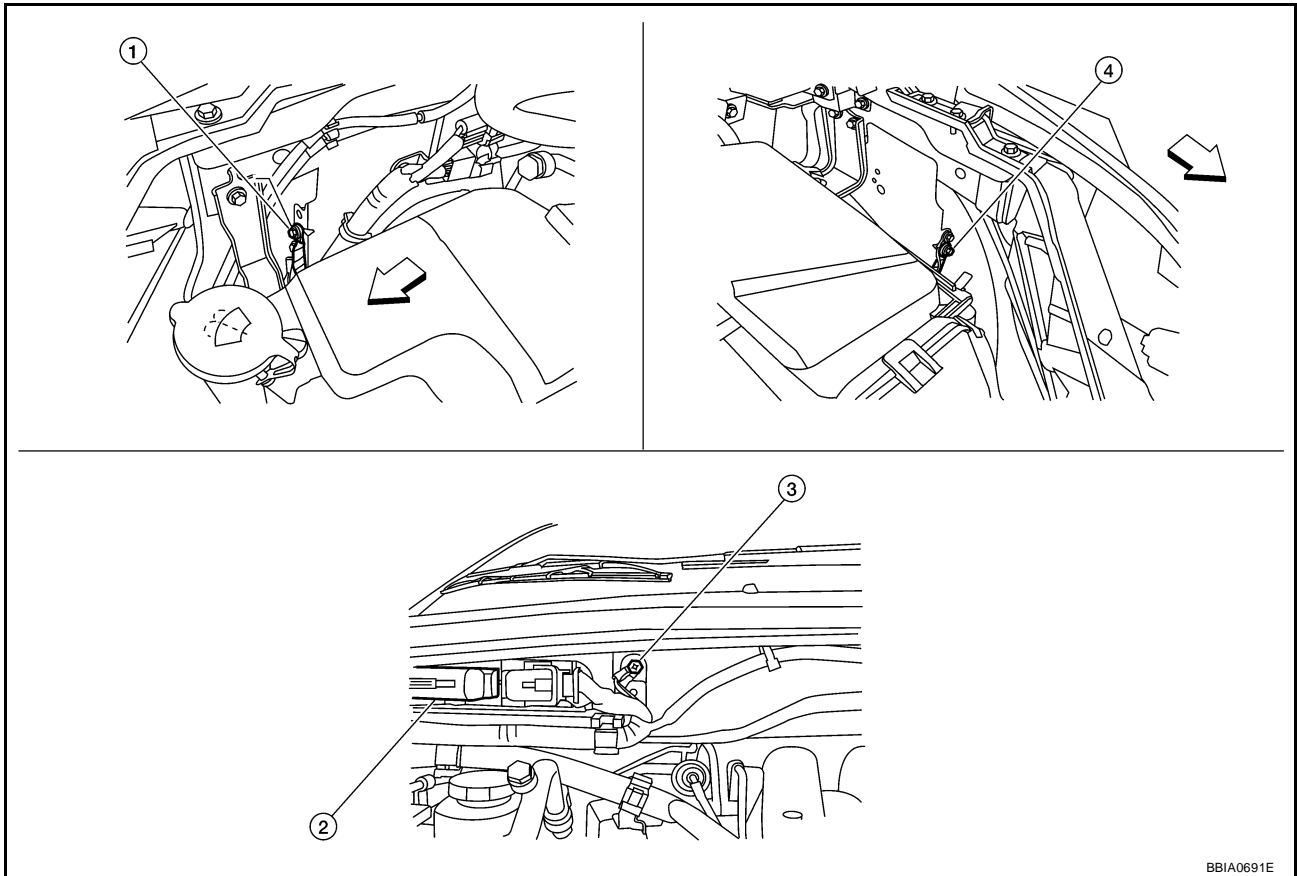

↔ Vehicle front

1. Body ground E24

2. ECM

3. Body ground E9

4. Body ground E15

OK or NG

OK >> GO TO 2.

NG >> Repair or replace ground connections.

BBIA0691E

DTC P0117, P0118 ECT SENSOR

2. CHECK ECT SENSOR POWER SUPPLY CIRCUIT

1. Disconnect engine coolant temperature (ECT) sensor harness connector.
2. Turn ignition switch ON.

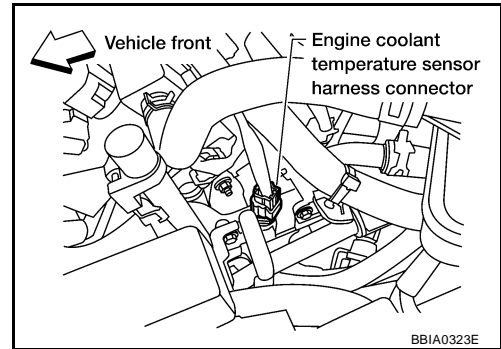

3. Check voltage between ECT sensor terminal 1 and ground with CONSULT-II or tester.

Voltage: Approximately 5V

OK or NG

OK >> GO TO 3.

NG >> Repair open circuit or short to ground or short to power in harness or connectors.

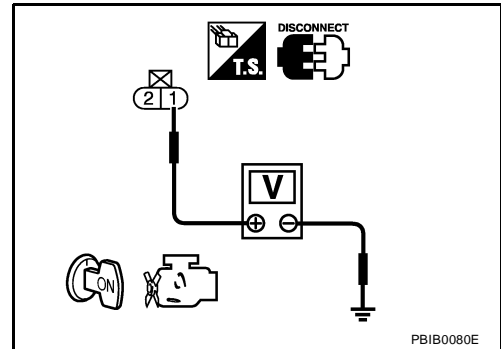

3. CHECK ECT SENSOR GROUND CIRCUIT FOR OPEN AND SHORT

1. Turn ignition switch OFF.
2. Disconnect ECM harness connector.
3. Check harness continuity between ECT sensor terminal 2 and ECM terminal 67. Refer to Wiring Diagram.

Continuity should exist.

4. Also check harness for short to ground and short to power.

OK or NG

OK >> GO TO 4.

NG >> Repair open circuit or short to ground or short to power in harness or connectors.

4. CHECK ENGINE COOLANT TEMPERATURE SENSOR

Refer to [EC-221, "Component Inspection"](#) .

OK or NG

OK >> GO TO 5.

NG >> Replace engine coolant temperature sensor.

5. CHECK INTERMITTENT INCIDENT

Refer to [EC-149, "TROUBLE DIAGNOSIS FOR INTERMITTENT INCIDENT"](#) .

>> INSPECTION END

DTC P0117, P0118 ECT SENSOR

UBS00P43

Component Inspection ENGINE COOLANT TEMPERATURE SENSOR

1. Check resistance between engine coolant temperature sensor terminals 1 and 2 as shown in the figure.

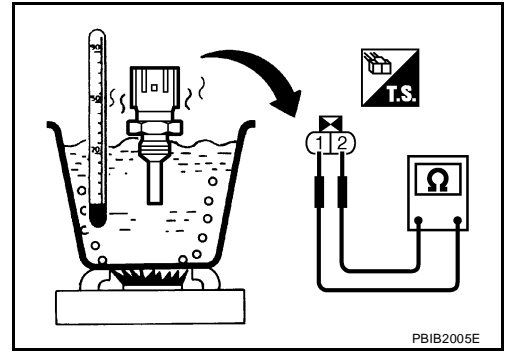

<Reference data>

Engine coolant temperature °C (°F)	Resistance kΩ
20 (68)	2.1 - 2.9
50 (122)	0.68 - 1.00
90 (194)	0.236 - 0.260

2. If NG, replace engine coolant temperature sensor.

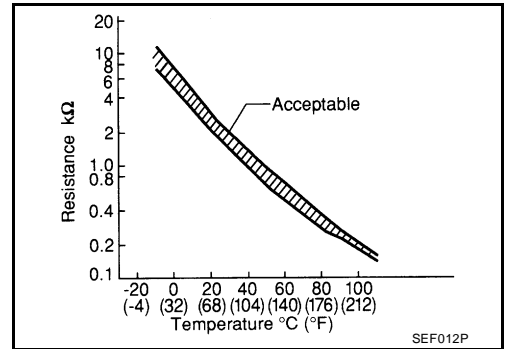

Removal and Installation ENGINE COOLANT TEMPERATURE SENSOR

Refer to [CO-23, "THERMOSTAT AND THERMOSTAT HOUSING"](#).

UBS00P44

DTC P0122, P0123 TP SENSOR

DTC P0122, P0123 TP SENSOR

PF1:16119

Component Description

UBS00P45

Electric throttle control actuator consists of throttle control motor, throttle position sensor, etc. The throttle position sensor responds to the throttle valve movement.

The throttle position sensor has the two sensors. These sensors are a kind of potentiometers which transform the throttle valve position into output voltage, and emit the voltage signal to the ECM. In addition, these sensors detect the opening and closing speed of the throttle valve and feed the voltage signals to the ECM. The ECM judges the current opening angle of the throttle valve from these signals and the ECM controls the throttle control motor to make the throttle valve opening angle properly in response to driving condition.

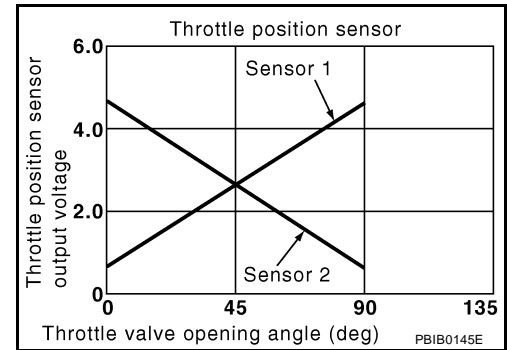

CONSULT-II Reference Value in Data Monitor Mode

UBS00P46

Specification data are reference values.

MONITOR ITEM	CONDITION	SPECIFICATION
THRTL SEN 1 THRTL SEN 2*	● Ignition switch: ON (Engine stopped)	Accelerator pedal: Fully released More than 0.36V
	● Shift lever: D	Accelerator pedal: Fully depressed Less than 4.75V

*: Throttle position sensor 2 signal is converted by ECM internally. Thus, it differs from ECM terminal voltage signal.

On Board Diagnosis Logic

UBS00P47

These self-diagnoses have the one trip detection logic.

DTC No.	Trouble diagnosis name	DTC detecting condition	Possible cause
P0122 0122	Throttle position sensor 2 circuit low input	An excessively low voltage from the TP sensor 2 is sent to ECM.	<ul style="list-style-type: none"> ● Harness or connectors (TP sensor 2 circuit is open or shorted.) (APP sensor 2 circuit is shorted.) ● Electric throttle control actuator (TP sensor 2) Accelerator pedal position sensor. (APP sensor 2)
P0123 0123	Throttle position sensor 2 circuit high input	An excessively high voltage from the TP sensor 2 is sent to ECM.	

FAIL-SAFE MODE

When the malfunction is detected, ECM enters fail-safe mode and the MIL lights up.

Engine operation condition in fail-safe mode

The ECM controls the electric throttle control actuator in regulating the throttle opening in order for the idle position to be within +10 degrees.

The ECM regulates the opening speed of the throttle valve to be slower than the normal condition.

So, the acceleration will be poor.

DTC P0122, P0123 TP SENSOR

UBS00P48

DTC Confirmation Procedure

NOTE:

If DTC Confirmation Procedure has been previously conducted, always turn ignition switch OFF and wait at least 10 seconds before conducting the next test.

TESTING CONDITION:

Before performing the following procedure, confirm that battery voltage is more than 10V at idle.

WITH CONSULT-II

1. Turn ignition switch ON.
2. Select "DATA MONITOR" mode with CONSULT-II.
3. Start engine and let it idle for 1 second.
4. If DTC is detected, go to [EC-226, "Diagnostic Procedure"](#) .

DATA MONITOR	
MONITOR	NO DTC
ENG SPEED	XXX rpm

SEF058Y

WITH GST

Follow the procedure "WITH CONSULT-II" above.

A
EC
C
D
E
F
G
H
I
J
K
L
M

DTC P0122, P0123 TP SENSOR

UBS00P49

Wiring Diagram

EC-TPS2-01

: DETECTABLE LINE FOR DTC
 : NON-DETECTABLE LINE FOR DTC

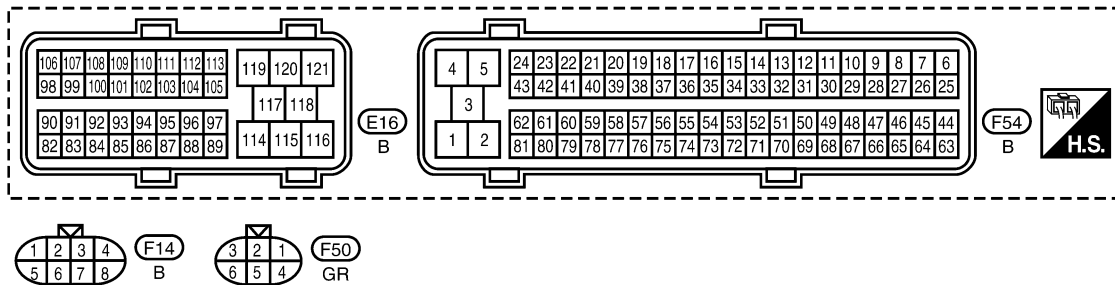
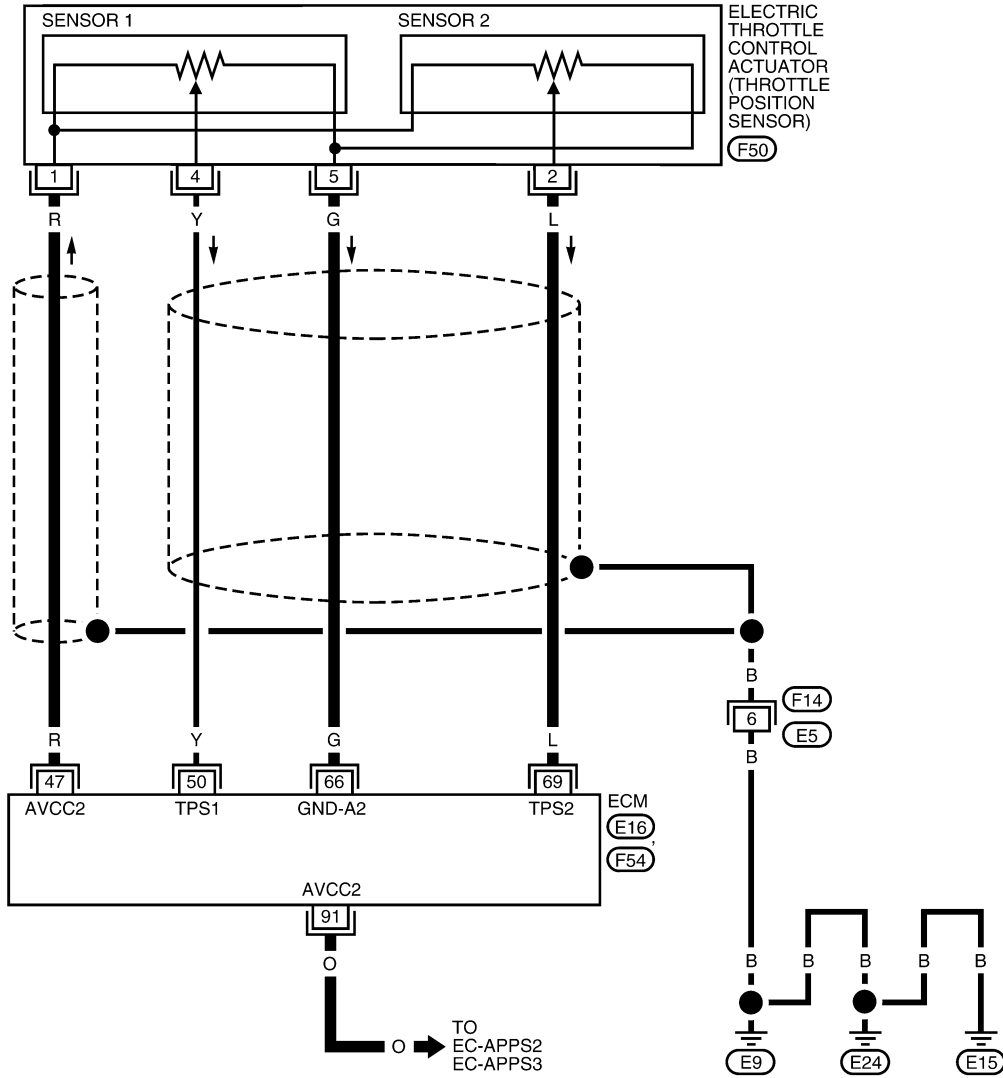

BBWA1604E

DTC P0122, P0123 TP SENSOR

Specification data are reference values and are measured between each terminal and ground.

CAUTION:

Do not use ECM ground terminals when measuring input/output voltage. Doing so may result in damage to the ECM's transistor. Use a ground other than ECM terminals, such as the ground.

TER-MINAL NO.	WIRE COLOR	ITEM	CONDITION	DATA (DC Voltage)
47	R	Throttle position sensor power supply	[Ignition switch: ON]	Approximately 5V
50	Y	Throttle position sensor 1	[Ignition switch: ON] <ul style="list-style-type: none"> ● Engine stopped ● Shift lever: D ● Accelerator pedal: Fully released 	More than 0.36V
			[Ignition switch: ON] <ul style="list-style-type: none"> ● Engine stopped ● Shift lever: D ● Accelerator pedal: Fully depressed 	Less than 4.75V
66	G	Throttle position sensor ground	[Engine is running] <ul style="list-style-type: none"> ● Warm-up condition ● Idle speed 	Approximately 0V
69	L	Throttle position sensor 2	[Ignition switch: ON] <ul style="list-style-type: none"> ● Engine stopped ● Shift lever: D ● Accelerator pedal: Fully released 	Less than 4.75V
			[Ignition switch: ON] <ul style="list-style-type: none"> ● Engine stopped ● Shift lever: D ● Accelerator pedal: Fully depressed 	More than 0.36V
91	O	APP sensor 2 power supply	[Ignition switch: ON]	Approximately 5V

A

EC

C

D

E

F

G

H

I

J

K

L

M

DTC P0122, P0123 TP SENSOR

UBS00P4A

Diagnostic Procedure

1. CHECK GROUND CONNECTIONS

1. Turn ignition switch OFF.
2. Loosen and retighten three ground screws on the body. Refer to [EC-158, "Ground Inspection"](#).

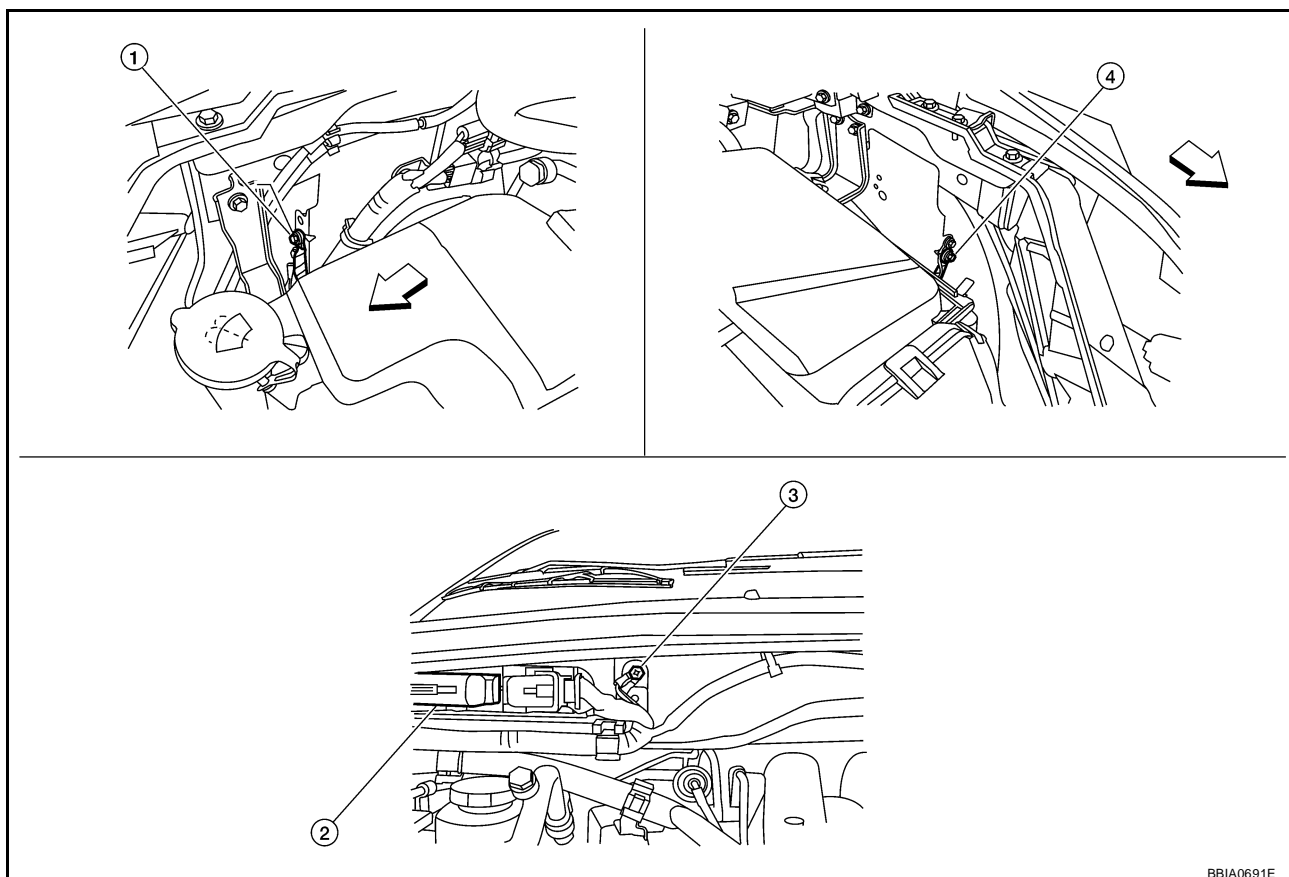

BBA0691E

← Vehicle front

1. Body ground E24

2. ECM

3. Body ground E9

4. Body ground E15

OK or NG

OK >> GO TO 2.

NG >> Repair or replace ground connections.

DTC P0122, P0123 TP SENSOR

2. CHECK THROTTLE POSITION SENSOR 2 POWER SUPPLY CIRCUIT-I

1. Disconnect electric throttle control actuator harness connector.
2. Turn ignition switch ON.

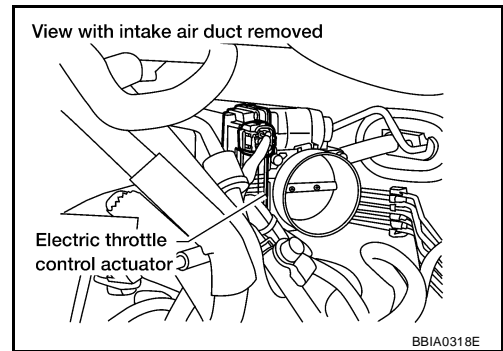

3. Check voltage between electric throttle control actuator terminal 1 and ground with CONSULT-II or tester.

Voltage: Approximately 5V

OK or NG

- OK >> GO TO 7.
NG >> GO TO 3.

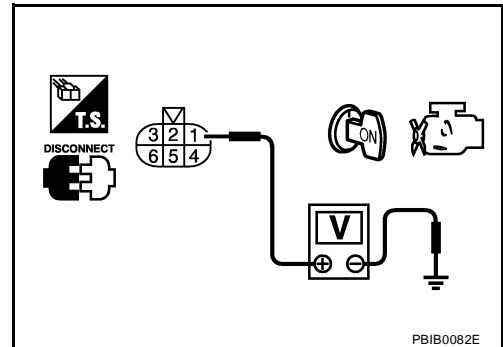

3. CHECK THROTTLE POSITION SENSOR 2 POWER SUPPLY CIRCUIT-II

1. Turn ignition switch OFF.
2. Disconnect ECM harness connector.
3. Check harness continuity between electric throttle control actuator terminal 1 and ECM terminal 47. Refer to Wiring Diagram.

Continuity should exist.

OK or NG

- OK >> GO TO 4.
NG >> Repair open circuit.

4. CHECK THROTTLE POSITION SENSOR 2 POWER SUPPLY CIRCUIT-III

Check harness for short to power and short to ground, between the following terminals.

ECM terminal	Sensor terminal	Reference Wiring Diagram
47	Electric throttle control actuator terminal 1	EC-224
91	APP sensor terminal 6	EC-626

OK or NG

- OK >> GO TO 5.
NG >> Repair short to ground or short to power in harness or connectors.

5. CHECK APP SENSOR

Refer to [EC-631, "Component Inspection"](#) .

OK or NG

- OK >> GO TO 11.
NG >> GO TO 6.

DTC P0122, P0123 TP SENSOR

6. REPLACE ACCELERATOR PEDAL ASSEMBLY

1. Replace accelerator pedal assembly.
2. Perform [EC-80, "Accelerator Pedal Released Position Learning"](#) .
3. Perform [EC-80, "Throttle Valve Closed Position Learning"](#) .
4. Perform [EC-80, "Idle Air Volume Learning"](#) .

>> INSPECTION END

7. CHECK THROTTLE POSITION SENSOR 2 GROUND CIRCUIT FOR OPEN AND SHORT

1. Turn ignition switch OFF.
2. Disconnect ECM harness connector.
3. Check harness continuity between ECM terminal 66 and electric throttle control actuator terminal 5.
Refer to Wiring Diagram.

Continuity should exist.

4. Also check harness for short to ground and short to power.

OK or NG

OK >> GO TO 8.

NG >> Repair open circuit or short to ground or short to power in harness or connectors.

8. CHECK THROTTLE POSITION SENSOR 2 INPUT SIGNAL CIRCUIT FOR OPEN AND SHORT

1. Check harness continuity between ECM terminal 69 and electric throttle control actuator terminal 2.
Refer to Wiring Diagram.

Continuity should exist.

2. Also check harness for short to ground and short to power.

OK or NG

OK >> GO TO 9.

NG >> Repair open circuit or short to ground or short to power in harness or connectors.

9. CHECK THROTTLE POSITION SENSOR

Refer to [EC-229, "Component Inspection"](#) .

OK or NG

OK >> GO TO 11.

NG >> GO TO 10.

10. REPLACE ELECTRIC THROTTLE CONTROL ACTUATOR

1. Replace the electric throttle control actuator.
2. Perform [EC-80, "Throttle Valve Closed Position Learning"](#) .
3. Perform [EC-80, "Idle Air Volume Learning"](#) .

>> INSPECTION END

11. CHECK INTERMITTENT INCIDENT

Refer to [EC-149, "TROUBLE DIAGNOSIS FOR INTERMITTENT INCIDENT"](#) .

>> INSPECTION END

DTC P0122, P0123 TP SENSOR

UBS00P4B

Component Inspection THROTTLE POSITION SENSOR

1. Reconnect all harness connectors disconnected.
2. Perform [EC-80, "Throttle Valve Closed Position Learning"](#).
3. Turn ignition switch ON.
4. Set shift lever to D position.
5. Check voltage between ECM terminals 50 (TP sensor 1 signal), 69 (TP sensor 2 signal) and ground under the following conditions.

Terminal	Accelerator pedal	Voltage
50 (Throttle position sensor 1)	Fully released	More than 0.36V
	Fully depressed	Less than 4.75V
69 (Throttle position sensor 2)	Fully released	Less than 4.75V
	Fully depressed	More than 0.36V

6. If NG, replace electric throttle control actuator and go to the next step.
7. Perform [EC-80, "Throttle Valve Closed Position Learning"](#).
8. Perform [EC-80, "Idle Air Volume Learning"](#).

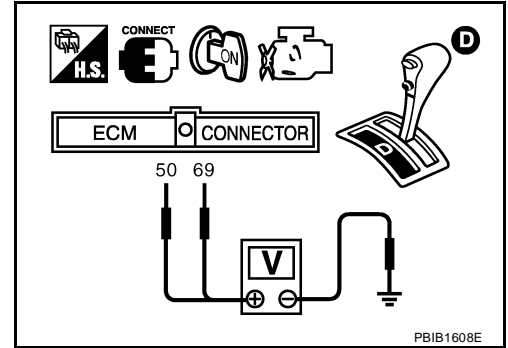

PBIB1608E

Removal and Installation ELECTRIC THROTTLE CONTROL ACTUATOR

UBS00P4C

Refer to [EM-18, "INTAKE MANIFOLD COLLECTOR"](#).

DTC P0125 ECT SENSOR

PFP:22630

DTC P0125 ECT SENSOR

Component Description

UBS00P4D

NOTE:

If DTC P0125 is displayed with P0117 or P0118, first perform the trouble diagnosis for DTC P0117 or P0118. Refer to [EC-216, "DTC P0117, P0118 ECT SENSOR"](#).

The engine coolant temperature sensor is used to detect the engine coolant temperature. The sensor modifies a voltage signal from the ECM. The modified signal returns to the ECM as the engine coolant temperature input. The sensor uses a thermistor which is sensitive to the change in temperature. The electrical resistance of the thermistor decreases as temperature increases.

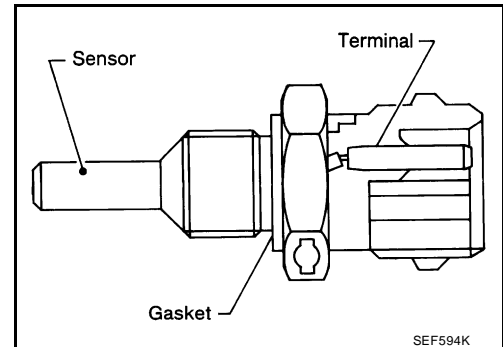

<Reference data>

Engine coolant temperature °C (°F)	Voltage* V	Resistance kΩ
-10 (14)	4.4	7.0 - 11.4
20 (68)	3.5	2.1 - 2.9
50 (122)	2.2	0.68 - 1.00
90 (194)	0.9	0.236 - 0.260

*: This data is reference value and is measured between ECM terminal 73 (Engine coolant temperature sensor) and ground.

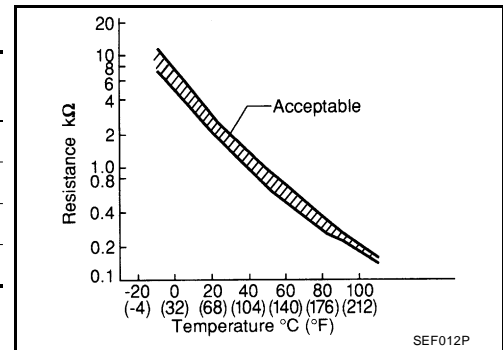

CAUTION:

Do not use ECM ground terminals when measuring input/output voltage. Doing so may result in damage to the ECM's transistor. Use a ground other than ECM terminals, such as the ground.

On Board Diagnosis Logic

UBS00P4E

DTC No.	Trouble diagnosis name	DTC detecting condition	Possible cause
P0125 0125	Insufficient engine coolant temperature for closed loop fuel control	<ul style="list-style-type: none"> ● Voltage sent to ECM from the sensor is not practical, even when some time has passed after starting the engine. ● Engine coolant temperature is insufficient for closed loop fuel control. 	<ul style="list-style-type: none"> ● Harness or connectors (High resistance in the circuit) ● Engine coolant temperature sensor ● Thermostat

DTC P0125 ECT SENSOR

UBS00P4F

DTC Confirmation Procedure

CAUTION:

Be careful not to overheat engine.

NOTE:

If DTC Confirmation Procedure has been previously conducted, always turn ignition switch OFF and wait at least 10 seconds before conducting the next test.

④ WITH CONSULT-II

1. Turn ignition switch ON.
2. Select "DATA MONITOR" mode with CONSULT-II.
3. Check that "COOLAN TEMP/S" is above 10°C (50°F).
If it is above 10°C (50°F), the test result will be OK.
If it is below 10°C (50°F), go to following step.
4. Start engine and run it for 65 minutes at idle speed.
If "COOLAN TEMP/S" increases to more than 10°C (50°F) within 65 minutes, stop engine because the test result will be OK.
5. If 1st trip DTC is detected, go to [EC-232, "Diagnostic Procedure"](#)

DATA MONITOR	
MONITOR	NO DTC
ENG SPEED	XXX rpm
COOLAN TEMP/S	XXX °C

SEF174Y

④ WITH GST

Follow the procedure "WITH CONSULT-II" above.

DTC P0125 ECT SENSOR

UBS00P4G

Diagnostic Procedure

1. CHECK GROUND CONNECTIONS

1. Turn ignition switch OFF.
2. Loosen and retighten three ground screws on the body. Refer to [EC-158, "Ground Inspection"](#).

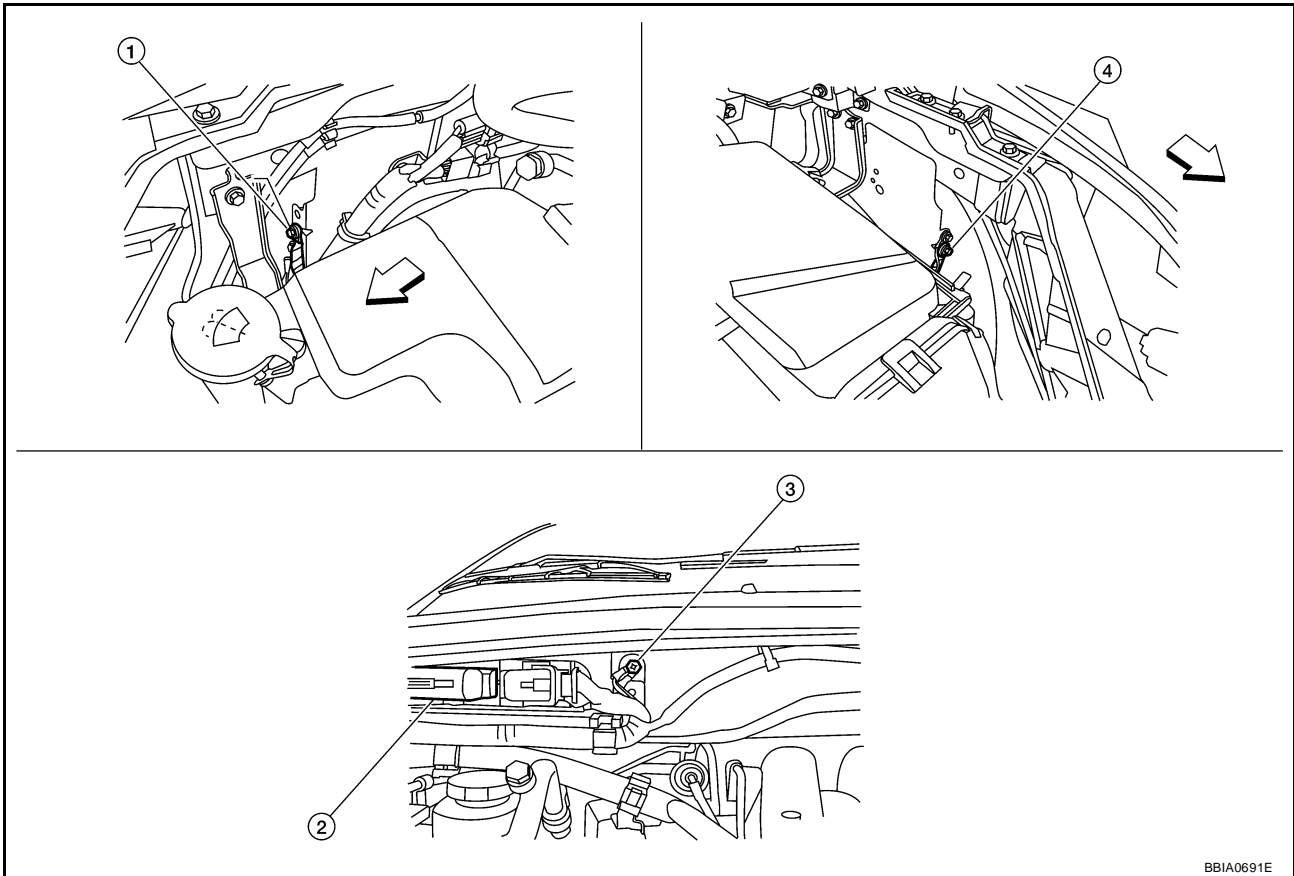

← Vehicle front

1. Body ground E24

2. ECM

3. Body ground E9

4. Body ground E15

BBA0691E

OK or NG

OK >> GO TO 2.

NG >> Repair or replace ground connections.

2. CHECK ENGINE COOLANT TEMPERATURE SENSOR

Refer to [EC-233, "Component Inspection"](#).

OK or NG

OK >> GO TO 3.

NG >> Replace engine coolant temperature sensor.

3. CHECK THERMOSTAT OPERATION

When the engine is cold [lower than 70°C (158°F)] condition, grasp lower radiator hose and confirm the engine coolant does not flow.

OK or NG

OK >> GO TO 4.

NG >> Repair or replace thermostat. Refer to [CO-23, "THERMOSTAT AND THERMOSTAT HOUSING"](#).

DTC P0125 ECT SENSOR

4. CHECK INTERMITTENT INCIDENT

Refer to [EC-149, "TROUBLE DIAGNOSIS FOR INTERMITTENT INCIDENT"](#) .
Refer to [EC-218, "Wiring Diagram"](#) .

>> INSPECTION END

Component Inspection ENGINE COOLANT TEMPERATURE SENSOR

1. Check resistance between engine coolant temperature sensor terminals 1 and 2 as shown in the figure.

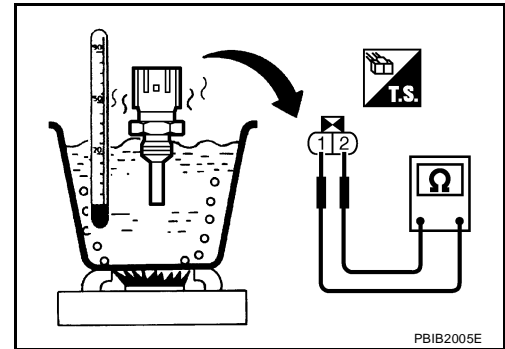

<Reference data>

Engine coolant temperature °C (°F)	Resistance kΩ
20 (68)	2.1 - 2.9
50 (122)	0.68 - 1.00
90 (194)	0.236 - 0.260

2. If NG, replace engine coolant temperature sensor.

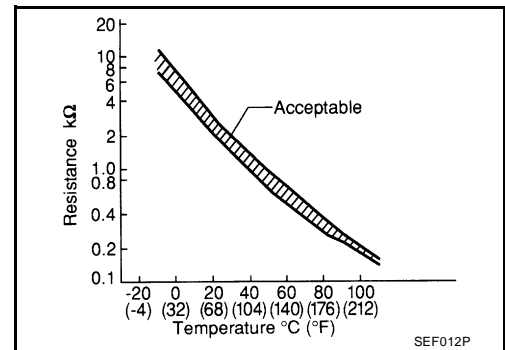

Removal and Installation ENGINE COOLANT TEMPERATURE SENSOR

Refer to [CO-23, "THERMOSTAT AND THERMOSTAT HOUSING"](#) .

DTC P0127 IAT SENSOR

PF P:22630

DTC P0127 IAT SENSOR

UBS00P4J

Component Description

The intake air temperature sensor is built into mass air flow sensor. The sensor detects intake air temperature and transmits a signal to the ECM.

The temperature sensing unit uses a thermistor which is sensitive to the change in temperature. Electrical resistance of the thermistor decreases in response to the temperature rise.

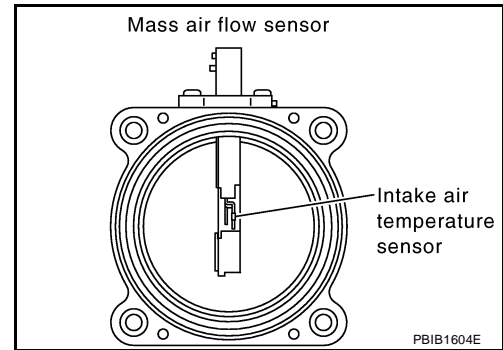

<Reference data>

Intake air temperature °C (°F)	Voltage* V	Resistance kΩ
25 (77)	3.32	1.800 - 2.200
80 (176)	1.23	0.283 - 0.359

*: This data is reference value and is measured between ECM terminal 34 (Intake air temperature sensor) and ground.

CAUTION:

Do not use ECM ground terminals when measuring input/output voltage. Doing so may result in damage to the ECM's transistor. Use a ground other than ECM terminals, such as the ground.

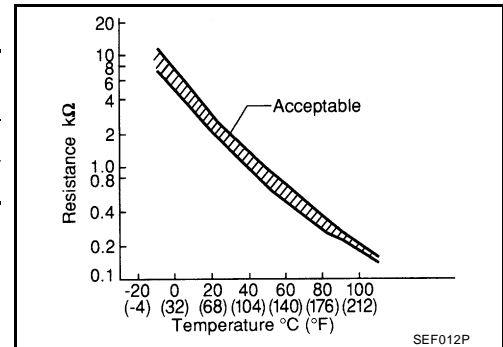

On Board Diagnosis Logic

UBS00P4K

DTC No.	Trouble diagnosis name	DTC detecting condition	Possible cause
P0127 0127	Intake air temperature too high	Rationally incorrect voltage from the sensor is sent to ECM, compared with the voltage signal from engine coolant temperature sensor.	<ul style="list-style-type: none"> ● Harness or connectors (The sensor circuit is open or shorted) ● Intake air temperature sensor

DTC Confirmation Procedure

UBS00P4L

NOTE:

If DTC Confirmation Procedure has been previously conducted, always turn ignition switch OFF and wait at least 10 seconds before conducting the next test.

CAUTION:

Always drive vehicle at a safe speed.

TESTING CONDITION:

This test may be conducted with the drive wheels lifted in the shop or by driving the vehicle. If a road test is expected to be easier, it is unnecessary to lift the vehicle.

WITH CONSULT-II

1. Wait until engine coolant temperature is less than 90°C (194°F)
 - a. Turn ignition switch ON.

DTC P0127 IAT SENSOR

- b. Select "DATA MONITOR" mode with CONSULT-II.
- c. Check the engine coolant temperature.
- d. If the engine coolant temperature is not less than 90°C (194°F), turn ignition switch OFF and cool down engine.
 - Perform the following steps before engine coolant temperature is above 90°C (194°F).
2. Turn ignition switch ON.
3. Select "DATA MONITOR" mode with CONSULT-II.
4. Start engine.
5. Hold vehicle speed at more than 70 km/h (43 MPH) for 100 consecutive seconds.
6. If 1st trip DTC is detected, go to [EC-235, "Diagnostic Procedure"](#).

DATA MONITOR	
MONITOR	NO DTC
ENG SPEED	XXX rpm
COOLAN TEMP/S	XXX °C
VHCL SPEED SE	XXX km/h
B/FUEL SCHDL	XXX msec

SEF189Y

WITH GST

Follow the procedure "WITH CONSULT-II" above.

Diagnostic Procedure

1. CHECK GROUND CONNECTIONS

1. Turn ignition switch OFF.
2. Loosen and retighten three ground screws on the body. Refer to [EC-158, "Ground Inspection"](#).

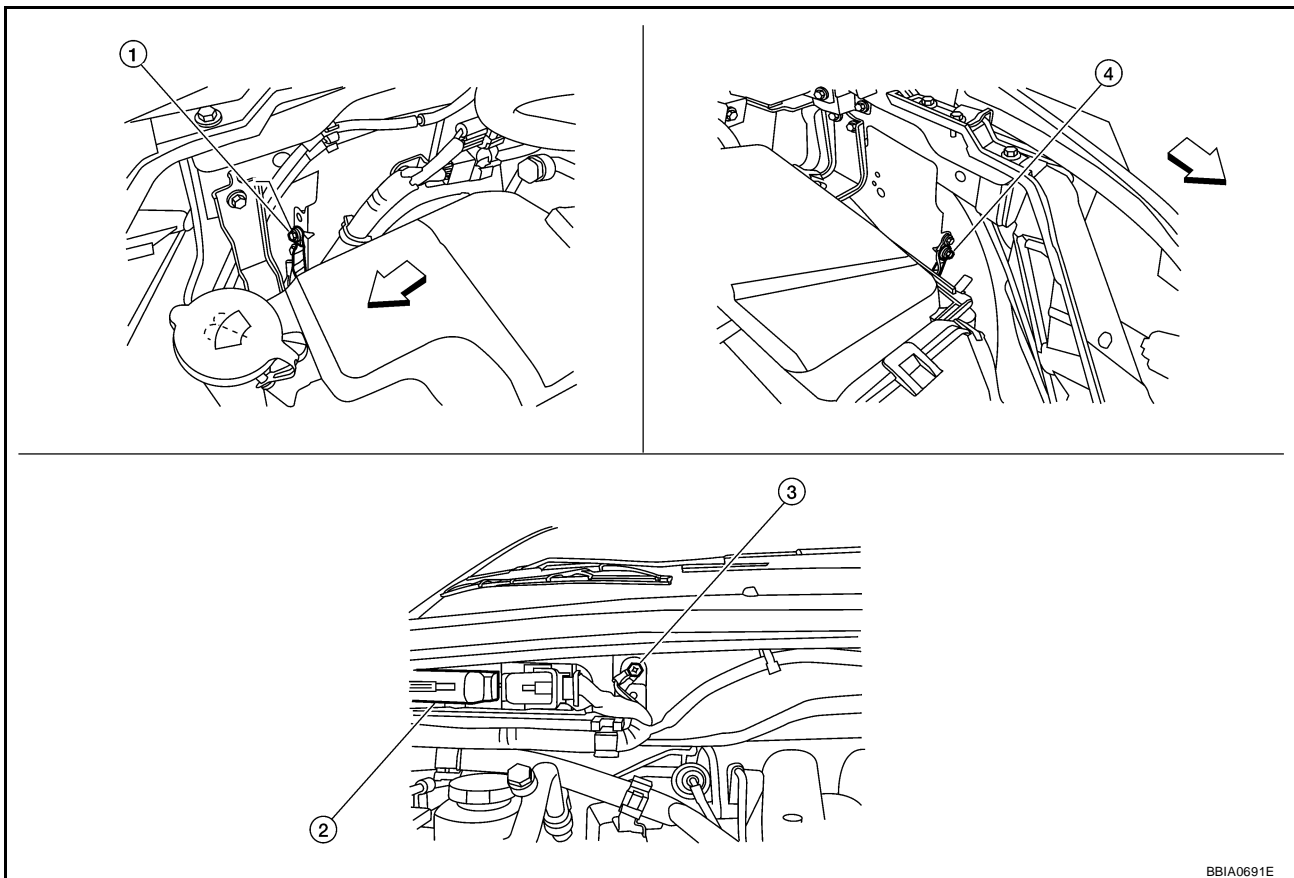

 Vehicle front

1. Body ground E24

2. ECM

3. Body ground E9

4. Body ground E15

OK or NG

OK >> GO TO 2.

NG >> Repair or replace ground connections.

DTC P0127 IAT SENSOR

2. CHECK INTAKE AIR TEMPERATURE SENSOR

Refer to [EC-236, "Component Inspection"](#) .

OK or NG

OK >> GO TO 3.

NG >> Replace mass air flow sensor (with intake air temperature sensor).

3. CHECK INTERMITTENT INCIDENT

Refer to [EC-149, "TROUBLE DIAGNOSIS FOR INTERMITTENT INCIDENT"](#) .

Refer to [EC-212, "Wiring Diagram"](#) .

>> INSPECTION END

Component Inspection INTAKE AIR TEMPERATURE SENSOR

UBS00P4N

1. Check resistance between intake air temperature sensor terminals 5 and 6 under the following conditions.

Intake air temperature °C (°F)	Resistance kΩ
25 (77)	1.800 - 2.200

2. If NG, replace mass air flow sensor (with intake air temperature sensor).

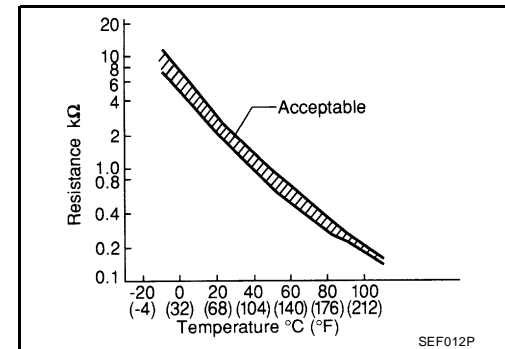
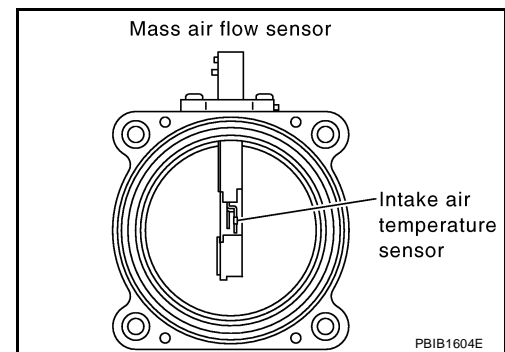

Removal and Installation MASS AIR FLOW SENSOR

UBS00P4O

Refer to [EM-16, "AIR CLEANER AND AIR DUCT"](#) .

DTC P0128 THERMOSTAT FUNCTION

DTC P0128 THERMOSTAT FUNCTION

PFP:21200

On Board Diagnosis Logic

UBS00P4P

Engine coolant temperature has not risen enough to open the thermostat even though the engine has run long enough.

This is due to a leak in the seal or the thermostat stuck open.

DTC No.	Trouble diagnosis name	DTC detecting condition	Possible cause
P0128 0128	Thermostat function	The engine coolant temperature does not reach to specified temperature even though the engine has run long enough.	<ul style="list-style-type: none">● Thermostat● Leakage from sealing portion of thermostat● Engine coolant temperature sensor

DTC Confirmation Procedure

UBS00P4Q

NOTE:

If DTC Confirmation Procedure has been previously conducted, always turn ignition switch OFF and wait at least 10 seconds before conducting the next test.

TESTING CONDITION:

- For best results, perform at ambient temperature of -10°C (14°F) or higher.
- For best results, perform at engine coolant temperature of -10°C (14°F) to 60°C (140°F).

WITH CONSULT-II

1. Replace thermostat with new one. Refer to [CO-23, "THERMOSTAT AND THERMOSTAT HOUSING"](#). Use only a genuine NISSAN thermostat as a replacement. If an incorrect thermostat is used, the MIL may come on.
2. Turn ignition switch ON.
3. Select "COOLAN TEMP/S" in "DATA MONITOR" mode with CONSULT-II.
4. Check that the "COOLAN TEMP/S" is above 60°C (140°F).
If it is below 60°C (140°F), go to following step.
If it is above 60°C (140°F), cool down the engine to less than 60°C (140°F), then retry from step 1.
5. Drive vehicle for 10 consecutive minutes under the following conditions.

VHCL SPEED SE	80 - 120 km/h (50 - 75 MPH)
---------------	-----------------------------

If 1st trip DTC is detected, go to [EC-237, "Diagnostic Procedure"](#).

WITH GST

1. Follow the procedure "WITH CONSULT-II" above.

Diagnostic Procedure

UBS00P4R

1. CHECK ENGINE COOLANT TEMPERATURE SENSOR

Refer to [EC-238, "Component Inspection"](#).

OK or NG

- OK >> **INSPECTION END**
- NG >> Replace engine coolant temperature sensor.

DTC P0128 THERMOSTAT FUNCTION

UBS00P4S

Component Inspection

ENGINE COOLANT TEMPERATURE SENSOR

1. Check resistance between engine coolant temperature sensor terminals 1 and 2.

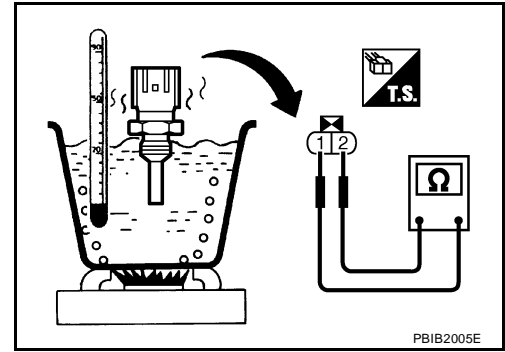

<Reference data>

Temperature °C (°F)	Resistance kΩ
20 (68)	2.1 - 2.9
50 (122)	0.68 - 1.0
90 (194)	0.236 - 0.260

2. If NG, replace engine coolant temperature sensor.

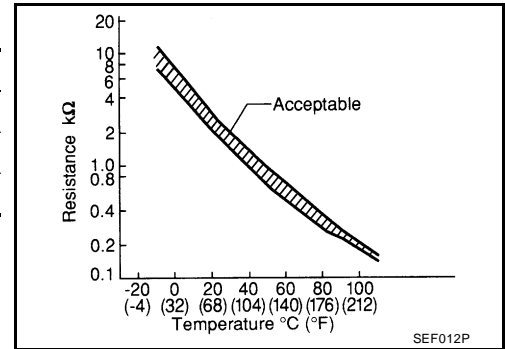

UBS00P4T

Removal and Installation

ENGINE COOLANT TEMPERATURE SENSOR

Refer to [CO-23, "THERMOSTAT AND THERMOSTAT HOUSING"](#) .

DTC P0130, P0150 A/F SENSOR 1

PFP:22693

DTC P0130, P0150 A/F SENSOR 1

UBS00P4U

Component Description

The A/F sensor is a planar dual-cell limit current sensor. The sensor element of the A/F sensor is the combination of a Nernst concentration cell (sensor cell) with an oxygen-pump cell, which transports ions. It has a heater in the element.

The sensor is capable of precise measurement $\lambda = 1$, but also in the lean and rich range. Together with its control electronics, the sensor outputs a clear, continuous signal throughout a wide λ range ($0.7 < \lambda < \text{air}$).

The exhaust gas components diffuse through the diffusion gap at the electrode of the oxygen pump and Nernst concentration cell, where they are brought to thermodynamic balance.

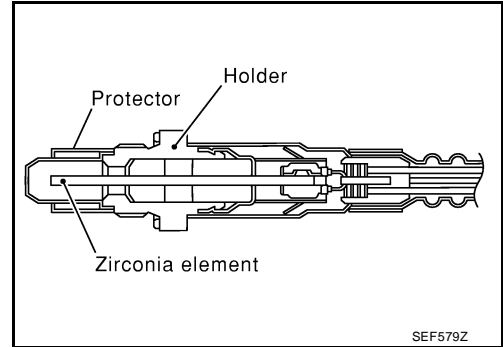

An electronic circuit controls the pump current through the oxygen-pump cell so that the composition of the exhaust gas in the diffusion gap remains constant at $\lambda = 1$. Therefore, the A/F sensor is able to indicate air/fuel ratio by this pumping of current. In addition, a heater is integrated in the sensor to ensure the required operating temperature of 700 - 800°C (1,292 - 1,472°F).

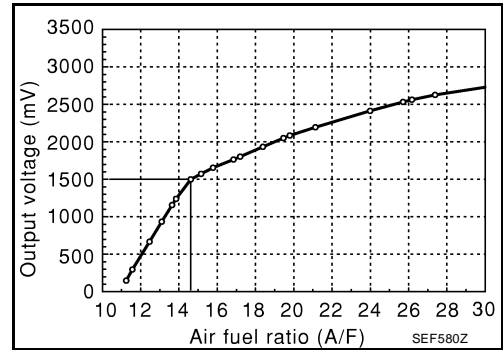

CONSULT-II Reference Value in Data Monitor Mode

UBS00P4V

Specification data are reference values.

MONITOR ITEM	CONDITION	SPECIFICATION
A/F SEN1 (B1) A/F SEN1 (B2)	● Engine: After warming up Maintaining engine speed at 2,000 rpm	Fluctuates around 1.5V

On Board Diagnosis Logic

UBS00P4W

To judge the malfunction, the diagnosis checks that the A/F signal computed by ECM from the air fuel ratio (A/F) sensor 1 signal fluctuates according to fuel feedback control.

DTC No.	Trouble diagnosis name	DTC detecting condition	Possible Cause
P0130 0130 (Bank 1)	Air fuel ratio (A/F) sensor 1 circuit	A) The A/F signal computed by ECM from the A/F sensor 1 signal is constantly in the range other than approx. 1.5V.	<ul style="list-style-type: none"> ● Harness or connectors (The A/F sensor 1 circuit is open or shorted.) ● Air fuel ratio (A/F) sensor 1
P0150 0150 (Bank 2)		B) The A/F signal computed by ECM from the A/F sensor 1 signal is constantly approx. 1.5V.	

DTC Confirmation Procedure

UBS00P4X

Perform PROCEDURE FOR MALFUNCTION A first.

If the DTC cannot be confirmed, perform PROCEDURE FOR MALFUNCTION B.

NOTE:

If DTC Confirmation Procedure has been previously conducted, always turn ignition switch OFF and wait at least 10 seconds before conducting the next test.

TESTING CONDITION:

Before performing the following procedure, confirm that battery voltage is more than 11V at idle.

PROCEDURE FOR MALFUNCTION A

Ⓟ With CONSULT-II

1. Start engine and warm it up to normal operating temperature.

DTC P0130, P0150 A/F SENSOR 1

2. Select "DATA MONITOR" mode with CONSULT-II.
3. Let engine idle for 2 minutes.
4. If 1st trip DTD is detected, go to [EC-246, "Diagnostic Procedure"](#)

DATA MONITOR	
MONITOR	NO DTC
ENG SPEED	XXX rpm
COOLAN TEMP/S	XXX °C

SEF174Y

With GST

Follow the procedure "With CONSULT-II" above.

PROCEDURE FOR MALFUNCTION B

CAUTION:

Always drive vehicle at a safe speed.

With CONSULT-II

1. Start engine and warm it up to normal operating temperature.
2. Select "A/F SEN1 (B1)" or "A/F SEN1 (B2)" in "DATA MONITOR" mode with CONSULT-II.
3. Check "A/F SEN1 (B1)" or "A/F SEN1 (B2)" indication.
If the indication is constantly approx. 1.5V and does not fluctuates, go to [EC-246, "Diagnostic Procedure"](#) .
If the indication fluctuates around 1.5V, go to next step.
4. Select "A/F SEN1 (B1) P1276" (for DTC P0130) or "A/F SEN1 (B2) P1286" (for DTC P0150) of "A/F SEN1" in "DTC WORK SUPPORT" mode with CONSULT-II.
5. Touch "START".
6. When the following conditions are met, "TESTING" will be displayed on the CONSULT-II screen.

ENG SPEED	1,100 - 3,200 rpm
VHCL SPEED SE	More than 64 km/h (40 MPH)
B/FUEL SCHDL	1.0 - 8.0 msec
Shift lever	D position with "OD" OFF

If "TESTING" is not displayed after 20 seconds, retry from step 2.

A/F SEN1 (B1) P1276	
OUT OF CONDITION	
MONITOR	
ENG SPEED	XXX rpm
B/FUEL SCHDL	XXX msec
COOLAN TEMP/S	XXX °C
VHCL SPEED SE	XXX km/h

SEF576Z

7. Release accelerator pedal fully.

NOTE:

Never apply brake during releasing the accelerator pedal.

A/F SEN1 (B1) P1276	
TESTING	
SELECT 3RD GEAR AND THEN RELEASE ACCELERATOR PEDAL OFF	
MONITOR	
ENG SPEED	XXX rpm
B/FUEL SCHDL	XXX msec
COOLAN TEMP/S	XXX °C
VHCL SPEED SE	XXX km/h

SEF577Z

DTC P0130, P0150 A/F SENSOR 1

8. Make sure that "TESTING" changes to "COMPLETED".
If "TESTING" changed to "OUT OF CONDITION", retry from step 6.
9. Make sure that "OK" is displayed after touching "SELF-DIAG RESULT".
If "NG" is displayed, go to [EC-246, "Diagnostic Procedure"](#).

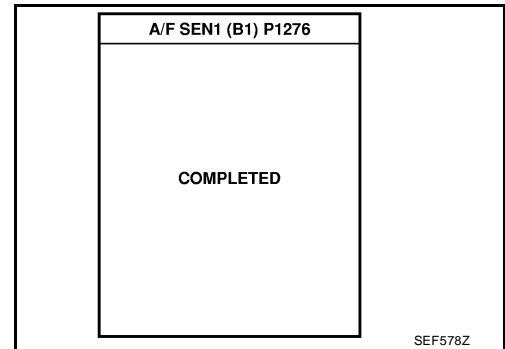

Overall Function Check

Use this procedure to check the overall function of the A/F sensor 1 circuit. During this check, a 1st trip DTC might not be confirmed.

WITH GST

1. Start engine and warm it up to normal operating temperature.
2. Drive the vehicle at a speed of 80 km/h (50 MPH) for a few minutes in the suitable gear position.
3. Set D position with "OD" OFF, then release the accelerator pedal fully until the vehicle speed decreases to 50 km/h (30 MPH).

NOTE:

Never apply brake during releasing the accelerator pedal.

4. Repeat steps 2 to 3 five times.
5. Stop the vehicle and turn ignition switch OFF.
6. Wait at least 10 seconds and restart engine.
7. Repeat steps 2 to 3 five times.
8. Stop the vehicle and connect GST to the vehicle.
9. Make sure that no DTC is displayed.
If 1st trip DTC is displayed, go to [EC-246, "Diagnostic Procedure"](#).

DTC P0130, P0150 A/F SENSOR 1

UBS00P4Z

Wiring Diagram BANK 1

EC-AF1B1-01

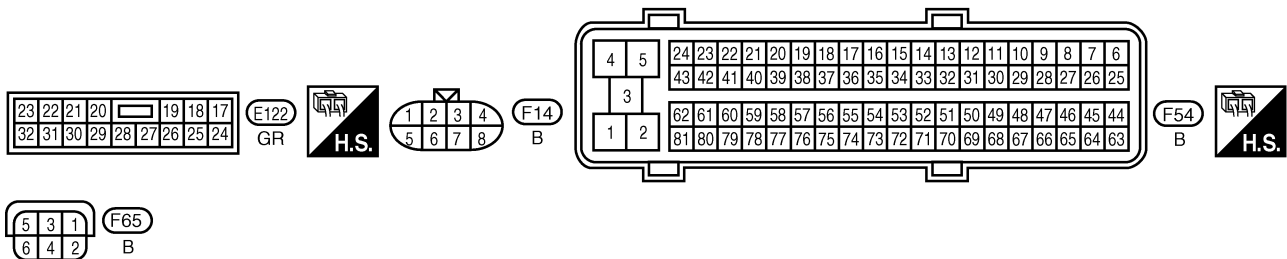
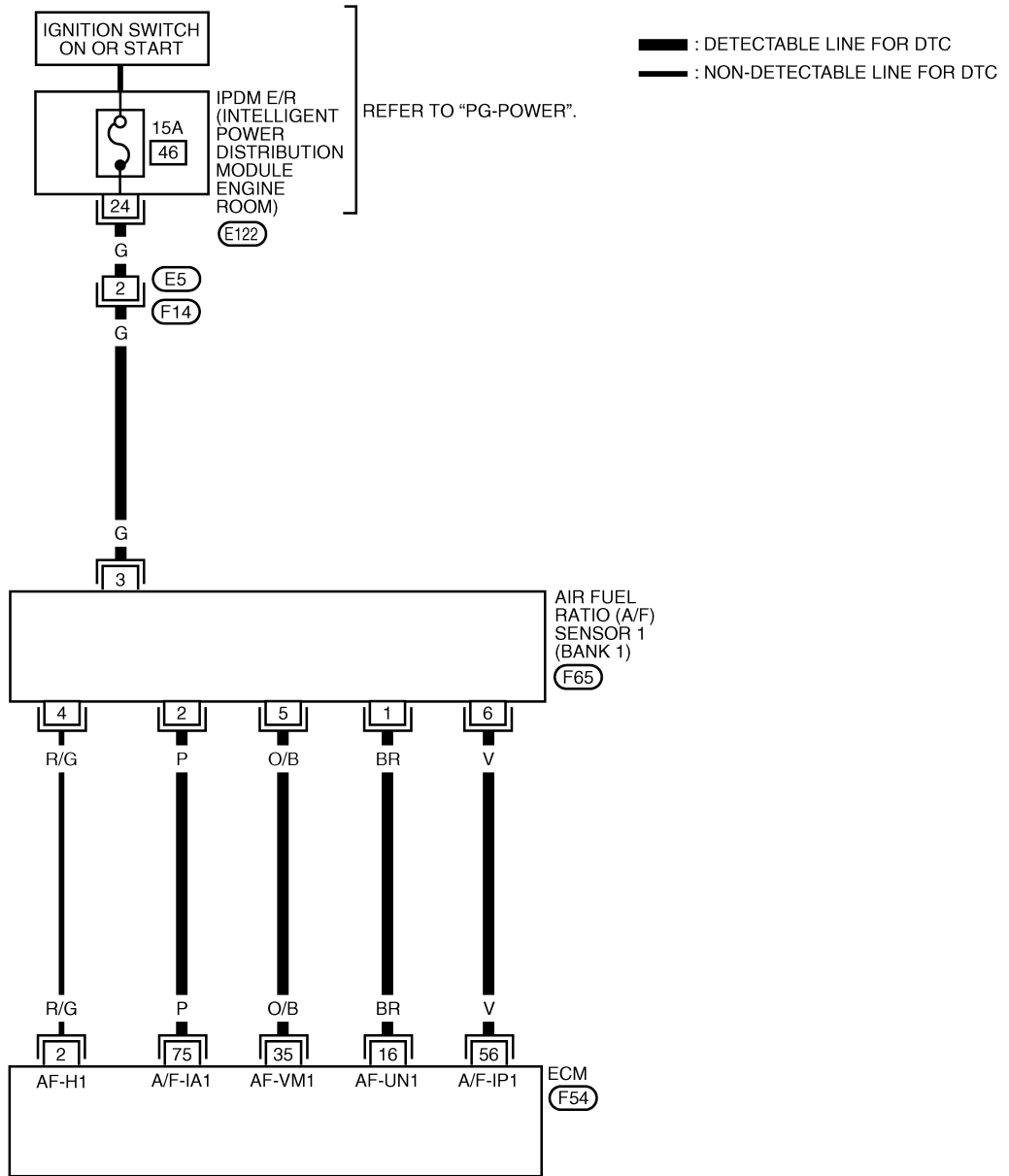

BBWA2503E

DTC P0130, P0150 A/F SENSOR 1

Specification data are reference values and are measured between each terminal and ground.
Pulse signal is measured by CONSULT-II.

CAUTION:

Do not use ECM ground terminals when measuring input/output voltage. Doing so may result in damage to the ECM's transistor. Use a ground other than ECM terminals, such as the ground.

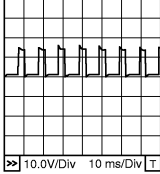
TERMI- NAL NO.	WIRE COLOR	ITEM	CONDITION	DATA (DC Voltage)
2	R/G	A/F sensor 1 heater (Bank 1)	[Engine is running] <ul style="list-style-type: none"> ● Warm-up condition ● Idle speed 	Approximately 5V★ 
16	BR	A/F sensor 1 (Bank 1)	[Engine is running] <ul style="list-style-type: none"> ● Warm-up condition ● Idle speed 	Approximately 3.1V
35	O/B			Approximately 2.6V
56	V			Approximately 2.3V
75	P			Approximately 2.3V

★: Average voltage for pulse signal (Actual pulse signal can be confirmed by oscilloscope.)

DTC P0130, P0150 A/F SENSOR 1

BANK 2

EC-AF1B2-01

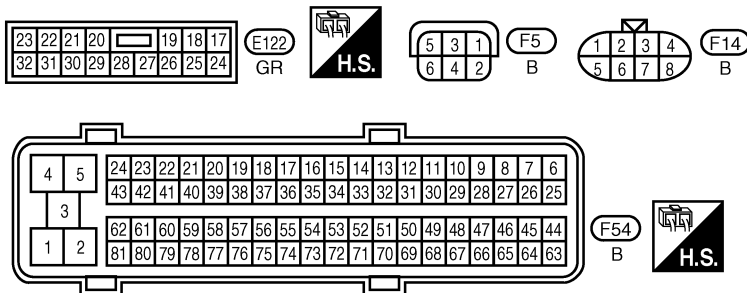
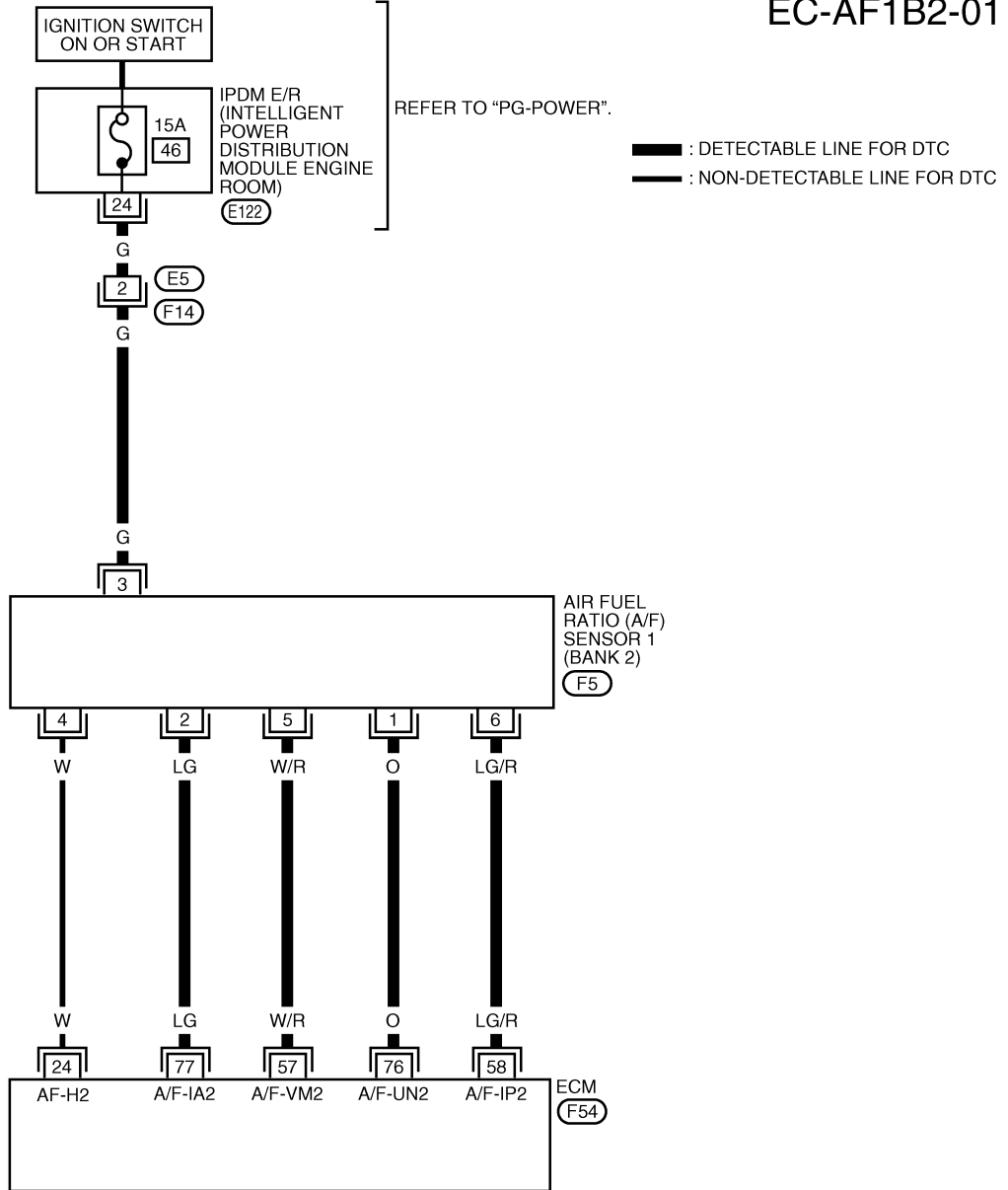

BBWA2504E

DTC P0130, P0150 A/F SENSOR 1

Specification data are reference values and are measured between each terminal and ground.
Pulse signal is measured by CONSULT-II.

CAUTION:

Do not use ECM ground terminals when measuring input/output voltage. Doing so may result in damage to the ECM's transistor. Use a ground other than ECM terminals, such as the ground.

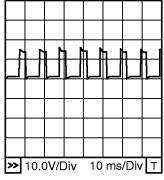
TERMI- NAL NO.	WIRE COLOR	ITEM	CONDITION	DATA (DC Voltage)
24	W	A/F sensor 1 heater (Bank 2)	[Engine is running] <ul style="list-style-type: none"> ● Warm-up condition ● Idle speed 	Approximately 5V★  <small>PBIB1584E</small>
57	W/R	A/F sensor 1 (Bank 2)	[Engine is running] <ul style="list-style-type: none"> ● Warm-up condition ● Idle speed 	Approximately 2.6V
58	LG/R			Approximately 2.3V
76	O			Approximately 3.1V
77	LG			Approximately 2.3V

★: Average voltage for pulse signal (Actual pulse signal can be confirmed by oscilloscope.)

DTC P0130, P0150 A/F SENSOR 1

UBS00P50

Diagnostic Procedure

1. CHECK GROUND CONNECTIONS

1. Turn ignition switch OFF.
2. Loosen and retighten three ground screws on the body. Refer to [EC-158, "Ground Inspection"](#).

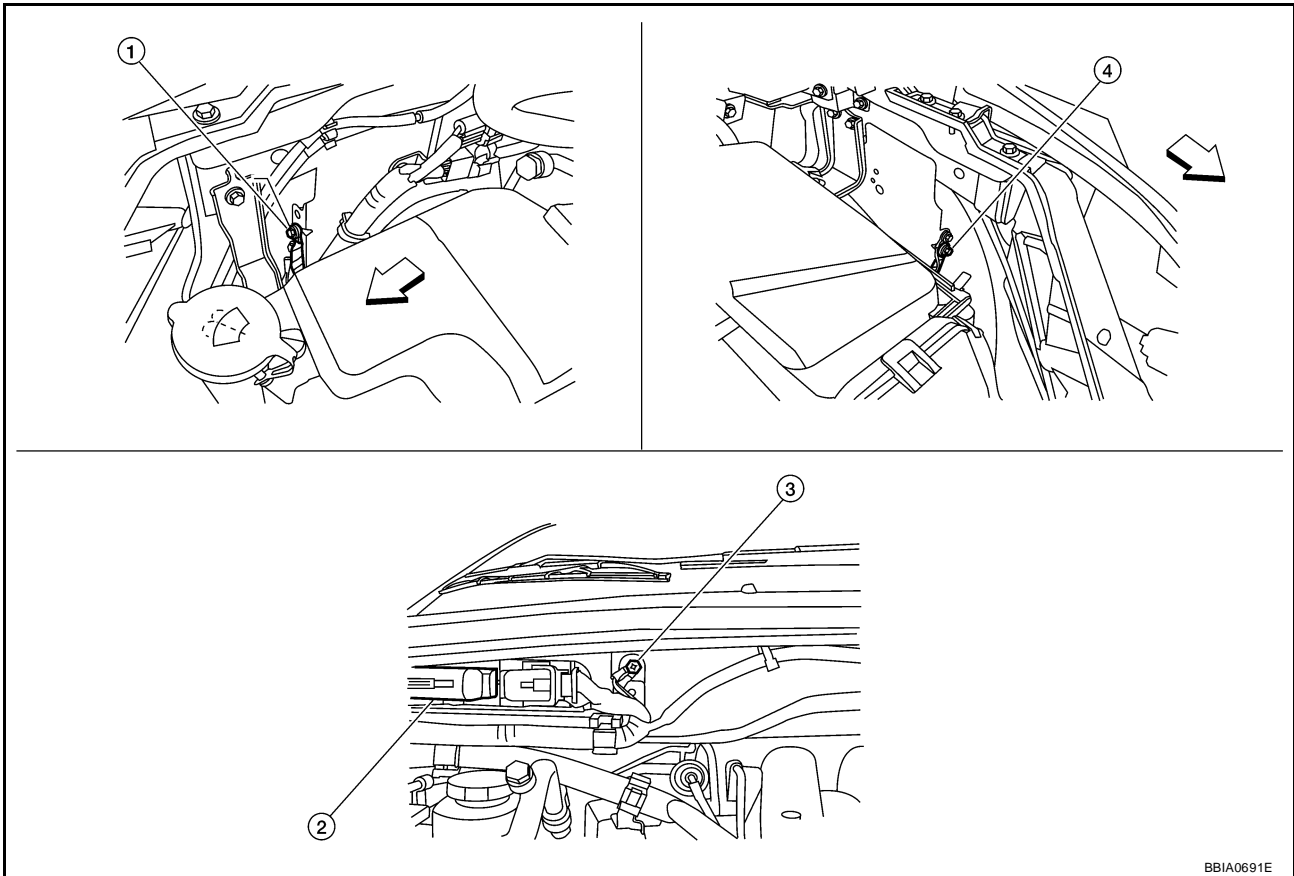

BBA0691E

← Vehicle front

1. Body ground E24

2. ECM

3. Body ground E9

4. Body ground E15

OK or NG

OK >> GO TO 2.

NG >> Repair or replace ground connections.

DTC P0130, P0150 A/F SENSOR 1

2. CHECK AIR FUEL RATIO (A/F) SENSOR 1 POWER SUPPLY CIRCUIT

1. Disconnect air fuel ratio (A/F) sensor 1 harness connector.

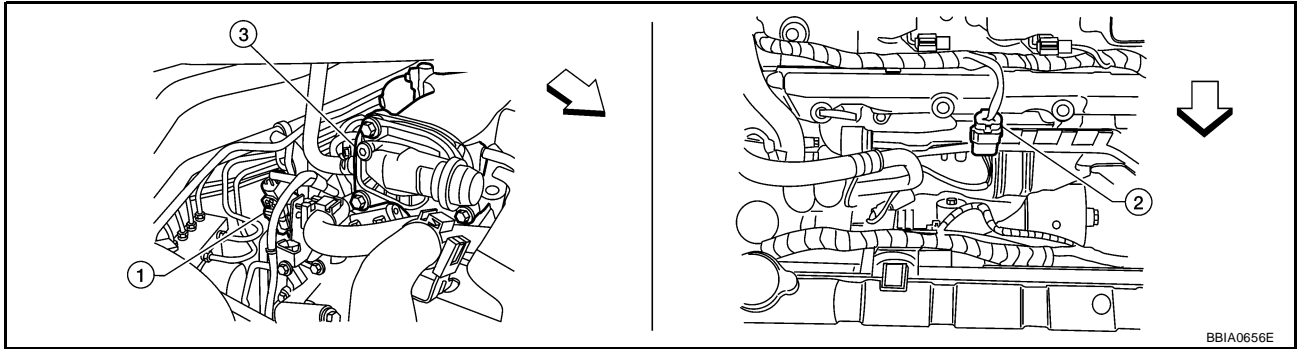

↶ Vehicle front

1. Air fuel ratio (A/F) sensor 1 (bank 1) harness connector
2. Air fuel ratio (A/F) sensor 1 (bank 2) harness connector
3. Intake manifold collector harness connector

2. Turn ignition switch ON.
3. Check voltage between A/F sensor 1 terminal 3 and ground with CONSULT-II or tester.

Voltage: Battery voltage

OK or NG

- OK >> GO TO 4.
- NG >> GO TO 3.

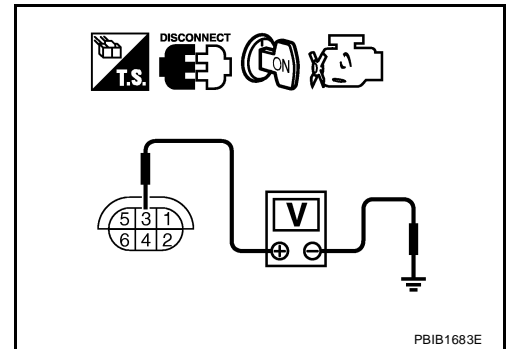

3. DETECT MALFUNCTIONING PART

Check the following.

- Harness connectors E5, F14
- IPDM E/R harness connector E122
- 15A fuse
- Harness for open or short between A/F sensor 1 and fuse

>> Repair or replace harness or connectors.

DTC P0130, P0150 A/F SENSOR 1

4. CHECK A/F SENSOR 1 INPUT SIGNAL CIRCUIT FOR OPEN AND SHORT

1. Turn ignition switch OFF.
2. Disconnect ECM harness connector.
3. Check harness continuity between the following terminals.
Refer to Wiring Diagram.

	A/F sensor 1 terminal	ECM terminal
Bank 1	1	16
	2	75
	5	35
	6	56
Bank 2	1	76
	2	77
	5	57
	6	58

Continuity should exist.

4. Check harness continuity between the following terminals and ground.
Refer to Wiring Diagram.

Bank 1		Bank 2	
A/F sensor 1 terminal	ECM terminal	A/F sensor 1 terminal	ECM terminal
1	16	1	76
2	75	2	77
5	35	5	57
6	56	6	58

Continuity should not exist.

5. Also check harness for short to power.

OK or NG

OK >> GO TO 5.

NG >> Repair open circuit or short to ground or short to power in harness or connectors.

5. CHECK INTERMITTENT INCIDENT

Perform [EC-149, "TROUBLE DIAGNOSIS FOR INTERMITTENT INCIDENT"](#) .

OK or NG

OK >> GO TO 6.

NG >> Repair or replace.

6. REPLACE AIR FUEL RATIO (A/F) SENSOR 1

Replace malfunctioning air fuel ratio (A/F) sensor 1.

CAUTION:

- Discard any air fuel ratio (A/F) sensor which has been dropped from a height of more than 0.5 m (19.7 in) onto a hard surface such as a concrete floor; use a new one.
- Before installing new air fuel ratio (A/F) sensor, clean exhaust system threads using Heated Oxygen Sensor Thread Cleaner tool J-43897-18 or J-43897-12 and approved anti-seize lubricant.

>> INSPECTION END

DTC P0130, P0150 A/F SENSOR 1

Removal and Installation AIR FUEL RATIO (A/F) SENSOR 1

UBS00P51

Refer to [EM-26, "EXHAUST MANIFOLD AND THREE WAY CATALYST"](#) .

A

EC

C

D

E

F

G

H

I

J

K

L

M

DTC P0131, P0151 A/F SENSOR 1

DTC P0131, P0151 A/F SENSOR 1

PFP:22693

Component Description

UBS00P52

The A/F sensor is a planar dual-cell limit current sensor. The sensor element of the A/F sensor is the combination of a Nernst concentration cell (sensor cell) with an oxygen-pump cell, which transports ions. It has a heater in the element.

The sensor is capable of precise measurement $\lambda = 1$, but also in the lean and rich range. Together with its control electronics, the sensor outputs a clear, continuous signal throughout a wide λ range ($0.7 < \lambda < \text{air}$).

The exhaust gas components diffuse through the diffusion gap at the electrode of the oxygen pump and Nernst concentration cell, where they are brought to thermodynamic balance.

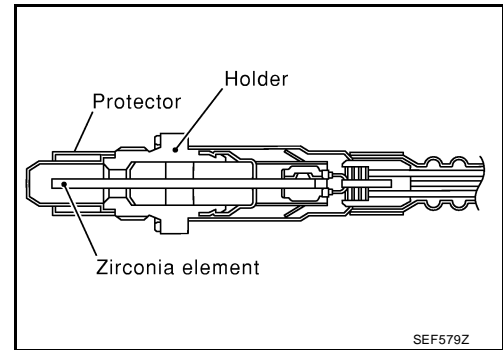

An electronic circuit controls the pump current through the oxygen-pump cell so that the composition of the exhaust gas in the diffusion gap remains constant at $\lambda = 1$. Therefore, the A/F sensor is able to indicate air/fuel ratio by this pumping of current. In addition, a heater is integrated in the sensor to ensure the required operating temperature of 700 - 800°C (1,292 - 1,472°F).

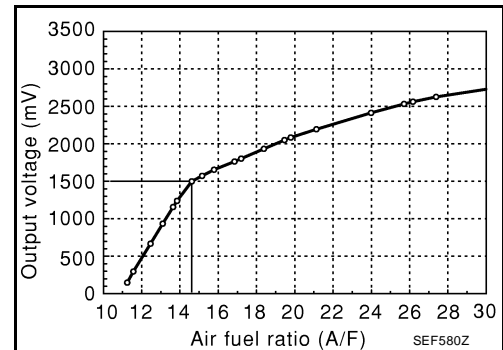

CONSULT-II Reference Value in Data Monitor Mode

UBS00P53

Specification data are reference values.

MONITOR ITEM	CONDITION	SPECIFICATION
A/F SEN1 (B1) A/F SEN1 (B2)	<ul style="list-style-type: none"> ● Engine: After warming up Maintaining engine speed at 2,000 rpm	Fluctuates around 1.5V

On Board Diagnosis Logic

UBS00P54

To judge the malfunction, the diagnosis checks that the A/F signal computed by ECM from the air fuel ratio (A/F) sensor 1 signal is not inordinately low.

DTC No.	Trouble diagnosis name	DTC detecting condition	Possible Cause
P0131 0131 (Bank 1)	Air fuel ratio (A/F) sensor 1 circuit low voltage	<ul style="list-style-type: none"> ● The A/F signal computed by ECM from the A/F sensor 1 signal is constantly approx. 0V. 	<ul style="list-style-type: none"> ● Harness or connectors (The A/F sensor 1 circuit is open or shorted.) ● Air fuel ratio (A/F) sensor 1
P0151 0151 (Bank 2)			

DTC Confirmation Procedure

UBS00P55

NOTE:

If DTC Confirmation Procedure has been previously conducted, always turn ignition switch OFF and wait at least 10 seconds before conducting the next test.

TESTING CONDITION:

Before performing the following procedure, confirm that battery voltage is more than 10.5V at idle.

④ WITH CONSULT-II

1. Start engine and warm it up to normal operating temperature.
2. Select "A/F SEN1 (B1)" or "A/F SEN1 (B2)" in "DATA MONITOR" mode with CONSULT-II.

DTC P0131, P0151 A/F SENSOR 1

3. Check "A/F SEN1 (B1)" or "A/F SEN1 (B2)" indication.
If the indication is constantly approx. 0V, go to [EC-256, "Diagnostic Procedure"](#).
If the indication is not constantly approx. 0V, go to next step.
4. Turn ignition switch OFF, wait at least 10 seconds and then restart engine.
5. Drive and accelerate vehicle to more than 40 km/h (25 MPH) within 20 seconds after restarting engine.
6. Maintain the following conditions for about 20 consecutive seconds.

DATA MONITOR	
MONITOR	NO DTC
ENG SPEED	XXX rpm
COOLANT TEMP/S	XXX °C
A/F SEN1 (B1)	XXX V

SEF581Z

ENG SPEED	1,000 - 3,200 rpm
VHCL SPEED SE	More than 40 km/h (25 MPH)
B/FUEL SCHDL	1.5 - 9.0 msec
Gear position	Suitable position

NOTE:

- Keep the accelerator pedal as steady as possible during the cruising.
 - If this procedure is not completed within 1 minute after restarting engine at step 4, return to step 4.
7. If 1st trip DTC is displayed, go to [EC-256, "Diagnostic Procedure"](#).

WITH GST

Follow the procedure "WITH CONSULT-II" above.

A
EC
C
D
E
F
G
H
I
J
K
L
M

DTC P0131, P0151 A/F SENSOR 1

UBS00P56

Wiring Diagram BANK 1

EC-AF1B1-01

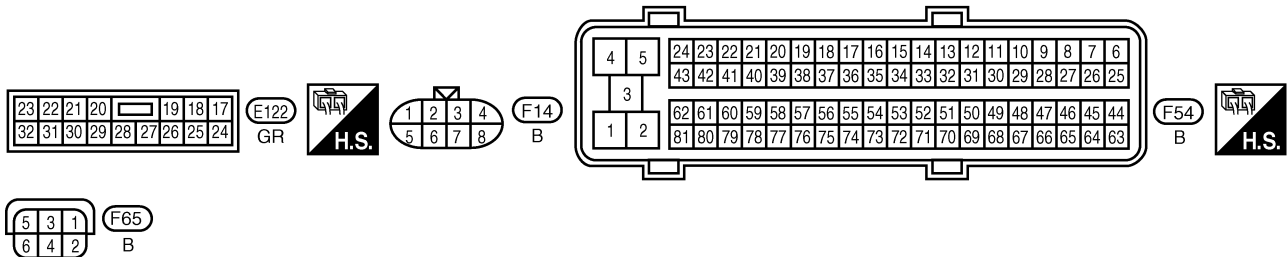
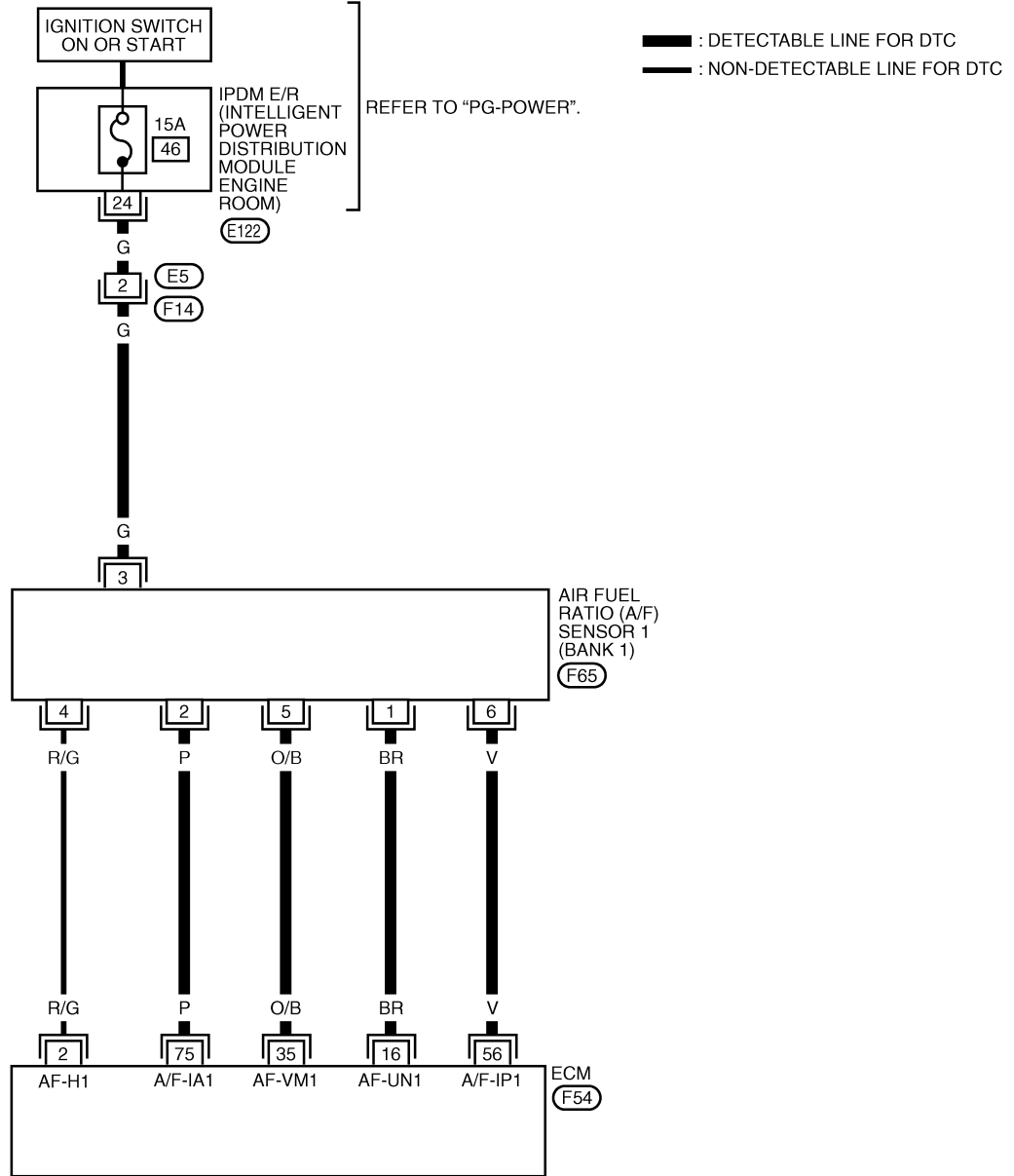

BBWA2503E

DTC P0131, P0151 A/F SENSOR 1

Specification data are reference values and are measured between each terminal and ground.
Pulse signal is measured by CONSULT-II.

CAUTION:

Do not use ECM ground terminals when measuring input/output voltage. Doing so may result in damage to the ECM's transistor. Use a ground other than ECM terminals, such as the ground.

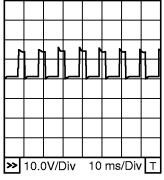
TERMI- NAL NO.	WIRE COLOR	ITEM	CONDITION	DATA (DC Voltage)
2	R/G	A/F sensor 1 heater (Bank 1)	[Engine is running] <ul style="list-style-type: none"> ● Warm-up condition ● Idle speed 	Approximately 5V★  <small>PBIB1584E</small>
16	BR	A/F sensor 1 (Bank 1)	[Engine is running] <ul style="list-style-type: none"> ● Warm-up condition ● Idle speed 	Approximately 3.1V
35	O/B			Approximately 2.6V
56	V			Approximately 2.3V
75	P			Approximately 2.3V

★: Average voltage for pulse signal (Actual pulse signal can be confirmed by oscilloscope.)

DTC P0131, P0151 A/F SENSOR 1

BANK 2

EC-AF1B2-01

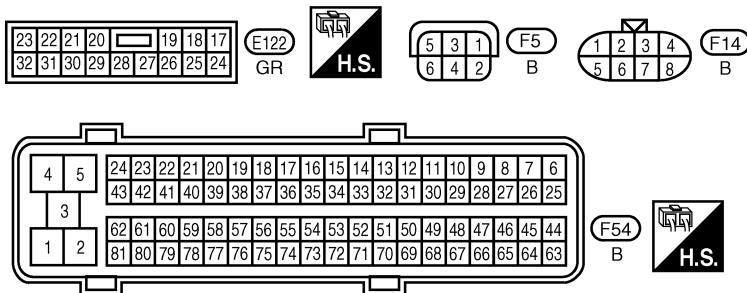
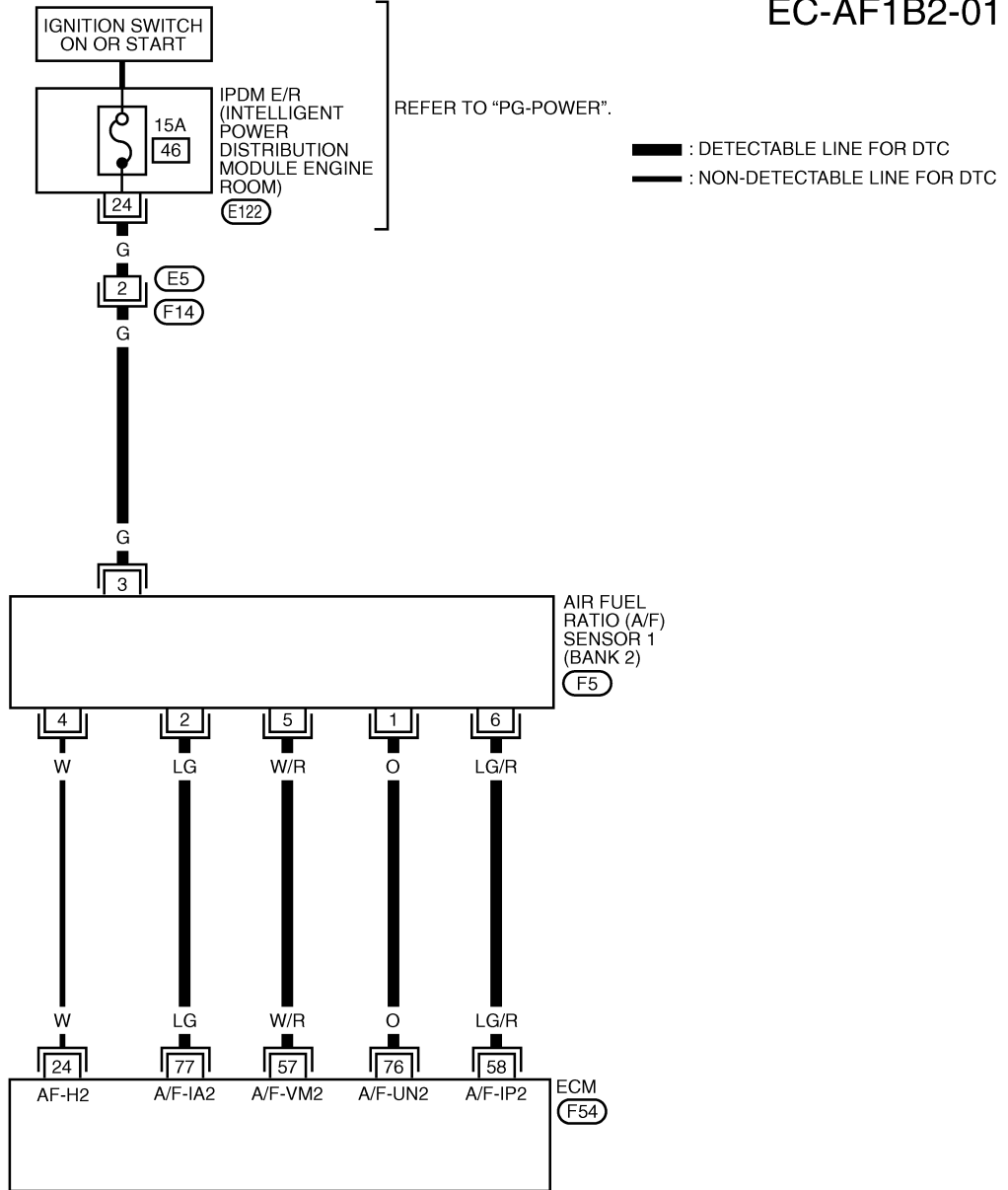

BBWA2504E

DTC P0131, P0151 A/F SENSOR 1

Specification data are reference values and are measured between each terminal and ground.
Pulse signal is measured by CONSULT-II.

CAUTION:

Do not use ECM ground terminals when measuring input/output voltage. Doing so may result in damage to the ECM's transistor. Use a ground other than ECM terminals, such as the ground.

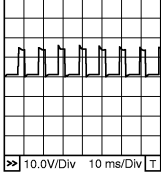
TERMI- NAL NO.	WIRE COLOR	ITEM	CONDITION	DATA (DC Voltage)
24	W	A/F sensor 1 heater (Bank 2)	[Engine is running] <ul style="list-style-type: none"> ● Warm-up condition ● Idle speed 	Approximately 5V★ 
57	W/R	A/F sensor 1 (Bank 2)	[Engine is running] <ul style="list-style-type: none"> ● Warm-up condition ● Idle speed 	Approximately 2.6V
58	LG/R			Approximately 2.3V
76	O			Approximately 3.1V
77	LG			Approximately 2.3V

★: Average voltage for pulse signal (Actual pulse signal can be confirmed by oscilloscope.)

DTC P0131, P0151 A/F SENSOR 1

UBS00P57

Diagnostic Procedure

1. CHECK GROUND CONNECTIONS

1. Turn ignition switch OFF.
2. Loosen and retighten three ground screws on the body. Refer to [EC-158, "Ground Inspection"](#).

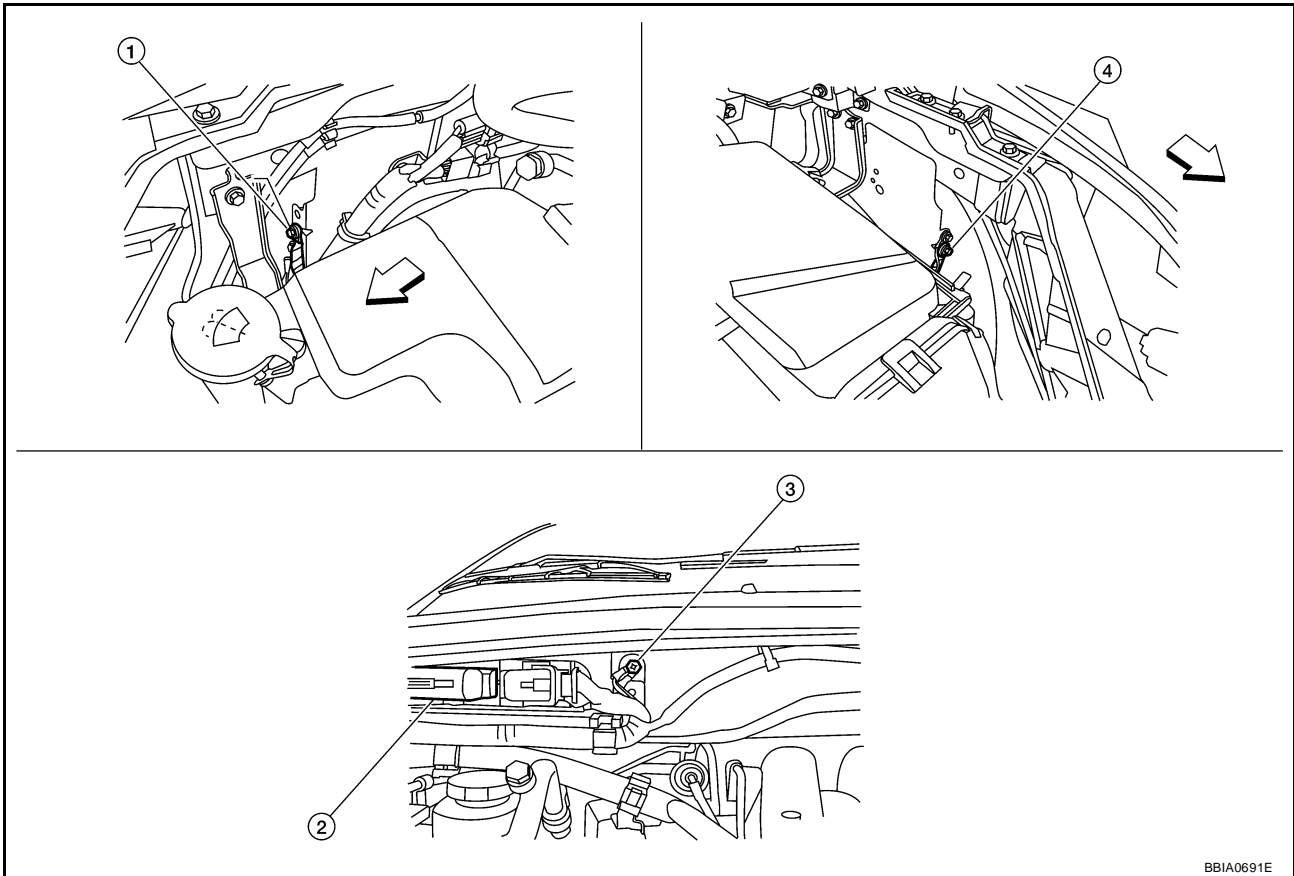

BBA0691E

← Vehicle front

1. Body ground E24

2. ECM

3. Body ground E9

4. Body ground E15

OK or NG

OK >> GO TO 2.

NG >> Repair or replace ground connections.

DTC P0131, P0151 A/F SENSOR 1

2. CHECK AIR FUEL RATIO (A/F) SENSOR 1 POWER SUPPLY CIRCUIT

1. Disconnect air fuel ratio (A/F) sensor 1 harness connector.

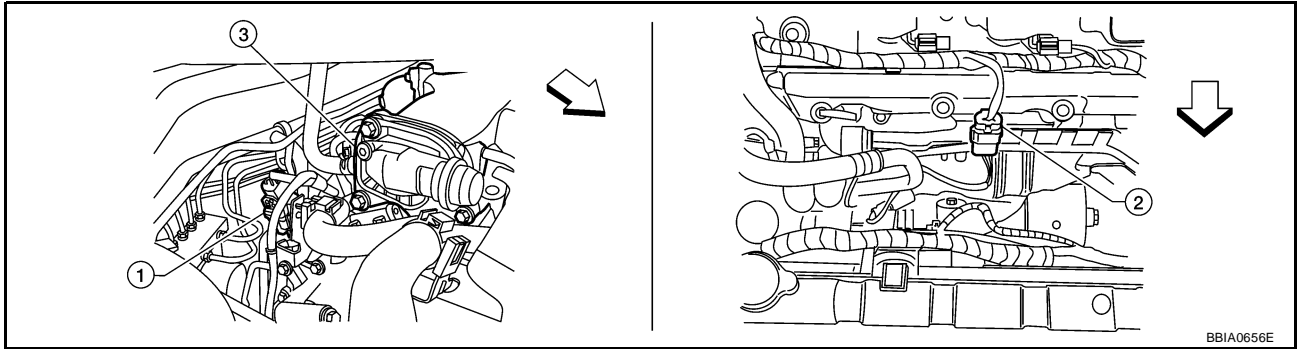

↶ Vehicle front

1. Air fuel ratio (A/F) sensor 1 (bank 1) harness connector
2. Air fuel ratio (A/F) sensor 1 (bank 2) harness connector
3. Intake manifold collector harness connector

2. Turn ignition switch ON.
3. Check voltage between A/F sensor 1 terminal 3 and ground with CONSULT-II or tester.

Voltage: Battery voltage

OK or NG

- OK >> GO TO 4.
- NG >> GO TO 3.

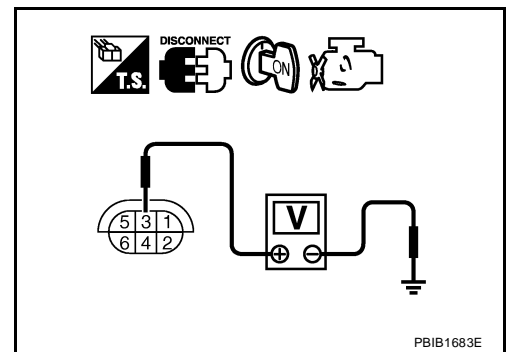

3. DETECT MALFUNCTIONING PART

Check the following.

- Harness connectors E5, F14
- IPDM E/R harness connector E122
- 15A fuse
- Harness for open or short between A/F sensor 1 and fuse

>> Repair or replace harness or connectors.

DTC P0131, P0151 A/F SENSOR 1

4. CHECK A/F SENSOR 1 INPUT SIGNAL CIRCUIT FOR OPEN AND SHORT

1. Turn ignition switch OFF.
2. Disconnect ECM harness connector.
3. Check harness continuity between the following terminals.
Refer to Wiring Diagram.

	A/F sensor 1 terminal	ECM terminal
Bank 1	1	16
	2	75
	5	35
	6	56
Bank 2	1	76
	2	77
	5	57
	6	58

Continuity should exist.

4. Check harness continuity between the following terminals and ground.
Refer to Wiring Diagram.

Bank 1		Bank 2	
A/F sensor 1 terminal	ECM terminal	A/F sensor 1 terminal	ECM terminal
1	16	1	76
2	75	2	77
5	35	5	57
6	56	6	58

Continuity should not exist.

5. Also check harness for short to power.

OK or NG

OK >> GO TO 5.

NG >> Repair open circuit or short to ground or short to power in harness or connectors.

5. CHECK INTERMITTENT INCIDENT

Perform [EC-149, "TROUBLE DIAGNOSIS FOR INTERMITTENT INCIDENT"](#) .

OK or NG

OK >> GO TO 6.

NG >> Repair or replace.

6. REPLACE AIR FUEL RATIO (A/F) SENSOR 1

Replace malfunctioning air fuel ratio (A/F) sensor 1.

CAUTION:

- Discard any air fuel ratio (A/F) sensor which has been dropped from a height of more than 0.5 m (19.7 in) onto a hard surface such as a concrete floor; use a new one.
- Before installing new air fuel ratio (A/F) sensor, clean exhaust system threads using Heated Oxygen Sensor Thread Cleaner tool J-43897-18 or J-43897-12 and approved anti-seize lubricant.

>> INSPECTION END

DTC P0131, P0151 A/F SENSOR 1

Removal and Installation AIR FUEL RATIO (A/F) SENSOR 1

UBS00P58

Refer to [EM-26, "EXHAUST MANIFOLD AND THREE WAY CATALYST"](#) .

A

EC

C

D

E

F

G

H

I

J

K

L

M

DTC P0132, P0152 A/F SENSOR 1

DTC P0132, P0152 A/F SENSOR 1

PFP:22693

Component Description

UBS00P59

The A/F sensor is a planar dual-cell limit current sensor. The sensor element of the A/F sensor is the combination of a Nernst concentration cell (sensor cell) with an oxygen-pump cell, which transports ions. It has a heater in the element.

The sensor is capable of precise measurement $\lambda = 1$, but also in the lean and rich range. Together with its control electronics, the sensor outputs a clear, continuous signal throughout a wide λ range ($0.7 < \lambda < \text{air}$).

The exhaust gas components diffuse through the diffusion gap at the electrode of the oxygen pump and Nernst concentration cell, where they are brought to thermodynamic balance.

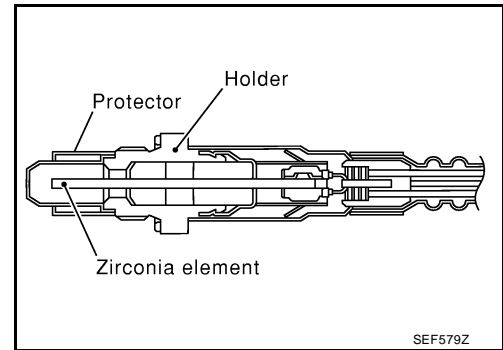

An electronic circuit controls the pump current through the oxygen-pump cell so that the composition of the exhaust gas in the diffusion gap remains constant at $\lambda = 1$. Therefore, the A/F sensor is able to indicate air/fuel ratio by this pumping of current. In addition, a heater is integrated in the sensor to ensure the required operating temperature of 700 - 800°C (1,292 - 1,472°F).

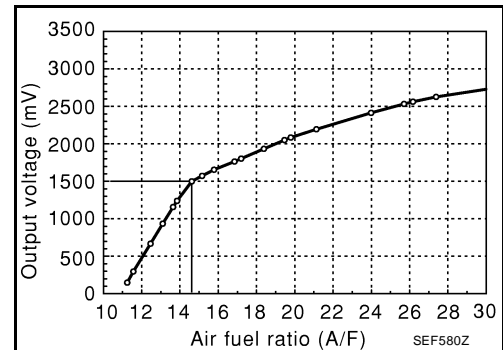

CONSULT-II Reference Value in Data Monitor Mode

UBS00P5A

Specification data are reference values.

MONITOR ITEM	CONDITION	SPECIFICATION
A/F SEN1 (B1) A/F SEN1 (B2)	<ul style="list-style-type: none"> ● Engine: After warming up Maintaining engine speed at 2,000 rpm	Fluctuates around 1.5V

On Board Diagnosis Logic

UBS00P5B

To judge the malfunction, the diagnosis checks that the A/F signal computed by ECM from the air fuel ratio (A/F) sensor 1 signal is not inordinately high.

DTC No.	Trouble diagnosis name	DTC detecting condition	Possible Cause
P0132 0132 (Bank 1) P0152 0152 (Bank 2)	Air fuel ratio (A/F) sensor 1 circuit high voltage	<ul style="list-style-type: none"> ● The A/F signal computed by ECM from the A/F sensor 1 signal is constantly approx. 5V. 	<ul style="list-style-type: none"> ● Harness or connectors (The A/F sensor 1 circuit is open or shorted.) ● Air fuel ratio (A/F) sensor 1

DTC Confirmation Procedure

UBS00P5C

NOTE:

If DTC Confirmation Procedure has been previously conducted, always turn ignition switch OFF and wait at least 10 seconds before conducting the next test.

TESTING CONDITION:

Before performing the following procedure, confirm that battery voltage is more than 10.5V at idle.

④ WITH CONSULT-II

1. Start engine and warm it up to normal operating temperature.
2. Select "A/F SEN1 (B1)" or "A/F SEN1 (B2)" in "DATA MONITOR" mode with CONSULT-II.

DTC P0132, P0152 A/F SENSOR 1

3. Check "A/F SEN1 (B1)" or "A/F SEN1 (B2)" indication.
If the indication is constantly approx. 5V, go to [EC-266, "Diagnostic Procedure"](#).
If the indication is not constantly approx. 5V, go to next step.
4. Turn ignition switch OFF, wait at least 10 seconds and then restart engine.
5. Drive and accelerate vehicle to more than 40 km/h (25 MPH) within 20 seconds after restarting engine.
6. Maintain the following conditions for about 20 consecutive seconds.

DATA MONITOR	
MONITOR	NO DTC
ENG SPEED	XXX rpm
COOLANT TEMP/S	XXX °C
A/F SEN1 (B1)	XXX V

SEF581Z

ENG SPEED	1,000 - 3,200 rpm
VHCL SPEED SE	More than 40 km/h (25 MPH)
B/FUEL SCHDL	1.5 - 9.0 msec
Gear position	Suitable position

NOTE:

- **Keep the accelerator pedal as steady as possible during the cruising.**
 - **If this procedure is not completed within 1 minute after restarting engine at step 4, return to step 4.**
7. If 1st trip DTC is displayed, go to [EC-266, "Diagnostic Procedure"](#).

WITH GST

Follow the procedure "WITH CONSULT-II" above.

A
EC
C
D
E
F
G
H
I
J
K
L
M

DTC P0132, P0152 A/F SENSOR 1

UBS00P5D

Wiring Diagram BANK 1

EC-AF1B1-01

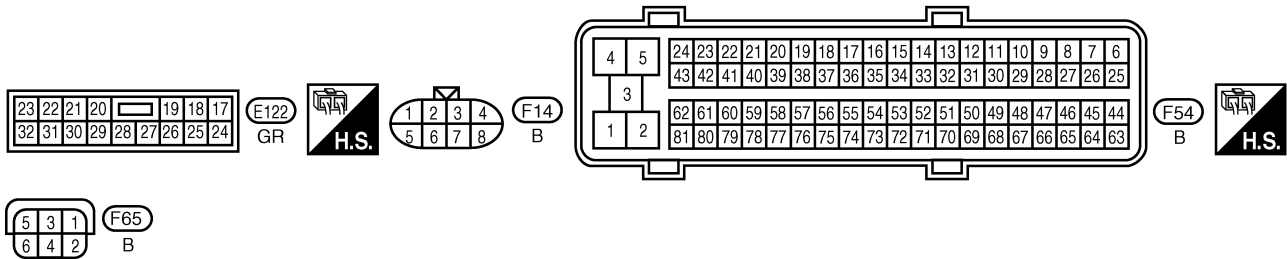
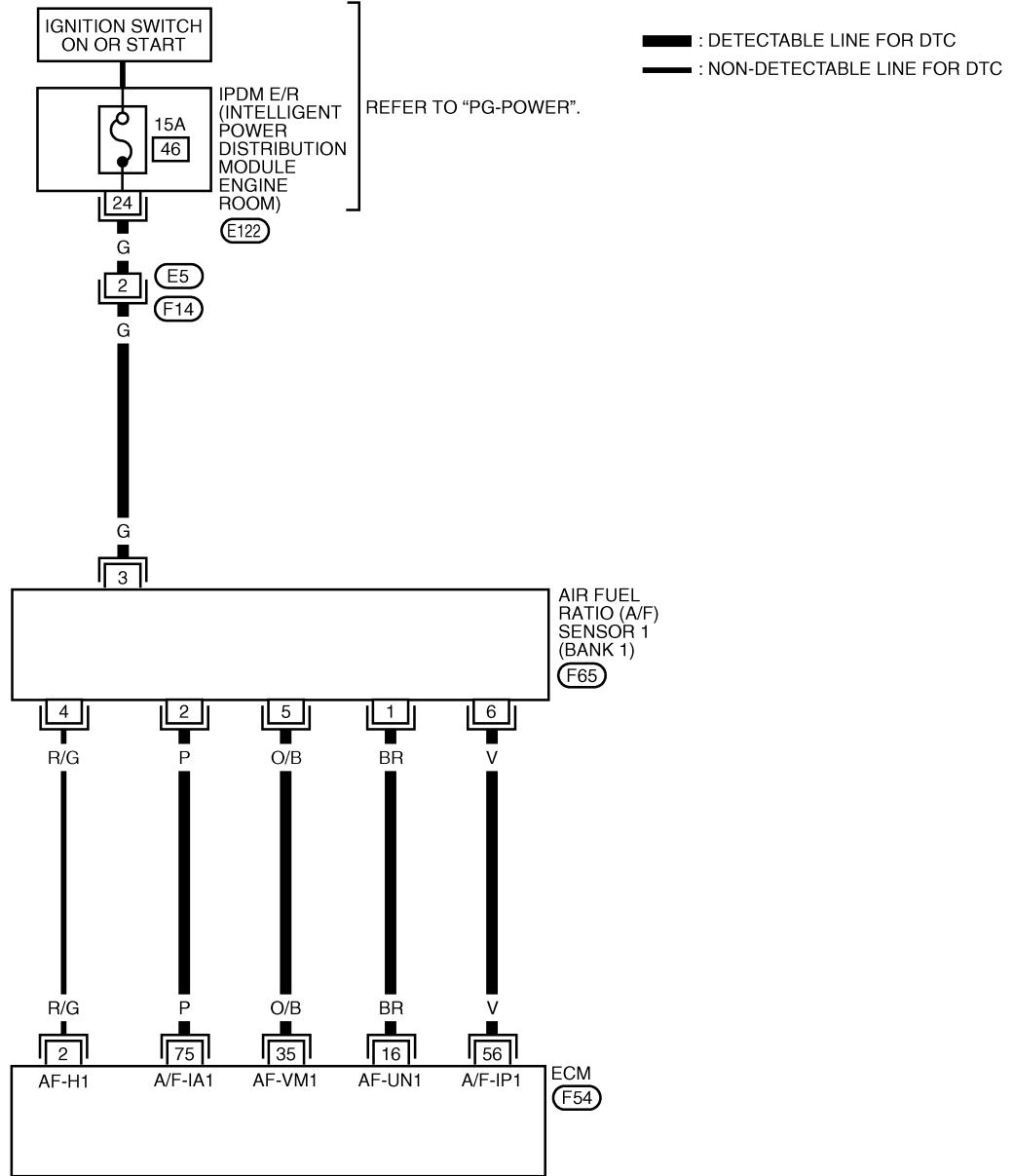

BBWA2503E

DTC P0132, P0152 A/F SENSOR 1

Specification data are reference values and are measured between each terminal and ground.
Pulse signal is measured by CONSULT-II.

CAUTION:

Do not use ECM ground terminals when measuring input/output voltage. Doing so may result in damage to the ECM's transistor. Use a ground other than ECM terminals, such as the ground.

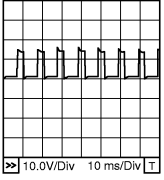
TERMI- NAL NO.	WIRE COLOR	ITEM	CONDITION	DATA (DC Voltage)
2	R/G	A/F sensor 1 heater (Bank 1)	[Engine is running] <ul style="list-style-type: none"> ● Warm-up condition ● Idle speed 	Approximately 5V★  <small>PBIB1584E</small>
16	BR	A/F sensor 1 (Bank 1)	[Engine is running] <ul style="list-style-type: none"> ● Warm-up condition ● Idle speed 	Approximately 3.1V
35	O/B			Approximately 2.6V
56	V			Approximately 2.3V
75	P			Approximately 2.3V

★: Average voltage for pulse signal (Actual pulse signal can be confirmed by oscilloscope.)

DTC P0132, P0152 A/F SENSOR 1

BANK 2

EC-AF1B2-01

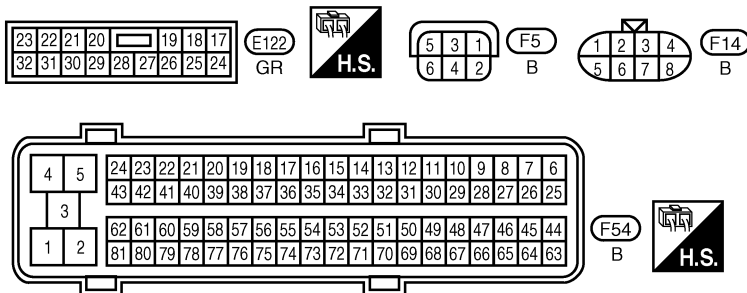
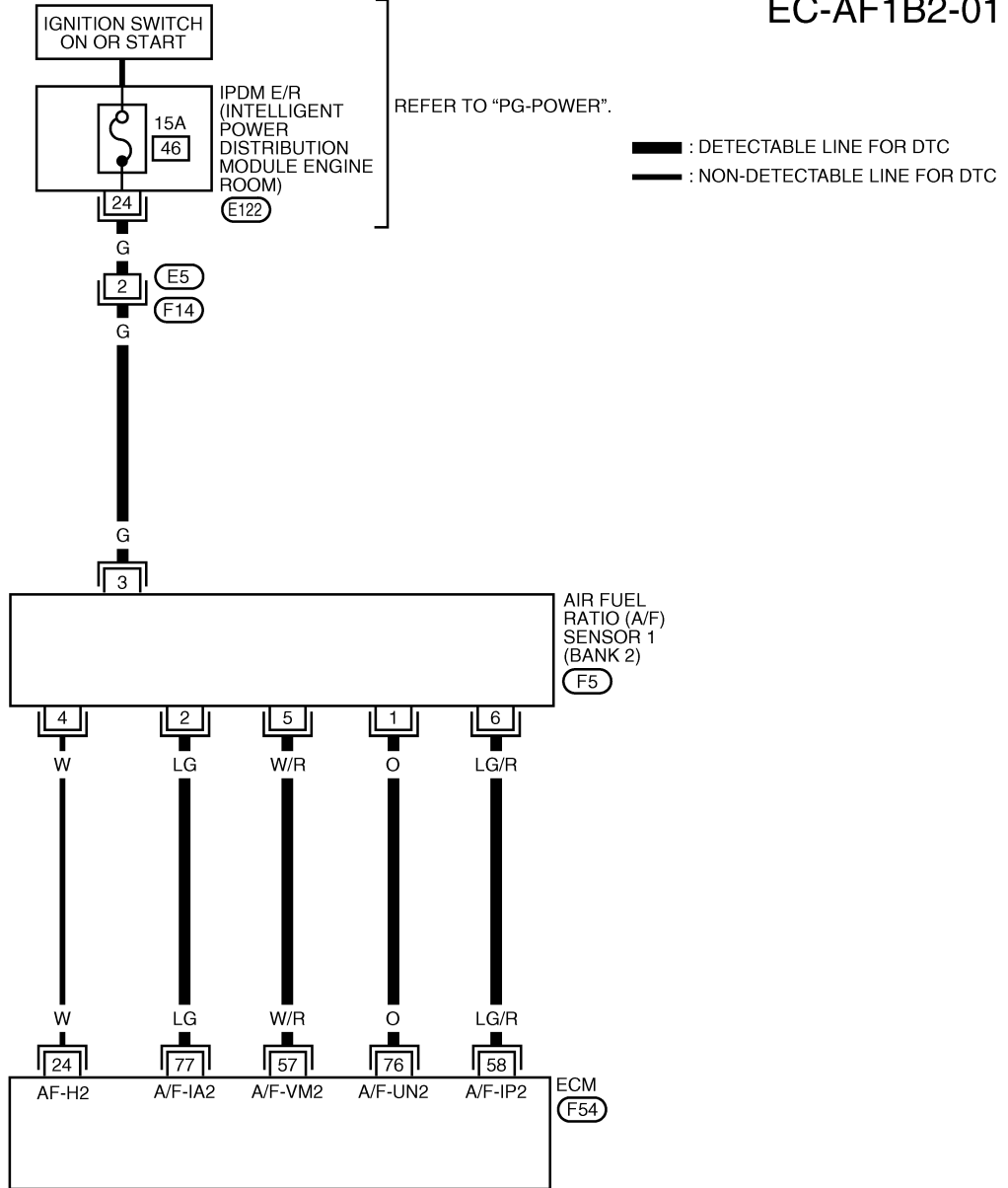

BBWA2504E

DTC P0132, P0152 A/F SENSOR 1

Specification data are reference values and are measured between each terminal and ground.
Pulse signal is measured by CONSULT-II.

CAUTION:

Do not use ECM ground terminals when measuring input/output voltage. Doing so may result in damage to the ECM's transistor. Use a ground other than ECM terminals, such as the ground.

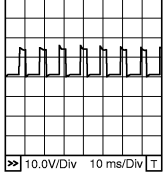
TERMI- NAL NO.	WIRE COLOR	ITEM	CONDITION	DATA (DC Voltage)
24	W	A/F sensor 1 heater (Bank 2)	[Engine is running] <ul style="list-style-type: none"> ● Warm-up condition ● Idle speed 	Approximately 5V★ 
57	W/R	A/F sensor 1 (Bank 2)	[Engine is running] <ul style="list-style-type: none"> ● Warm-up condition ● Idle speed 	Approximately 2.6V
58	LG/R			Approximately 2.3V
76	O			Approximately 3.1V
77	LG			Approximately 2.3V

★: Average voltage for pulse signal (Actual pulse signal can be confirmed by oscilloscope.)

DTC P0132, P0152 A/F SENSOR 1

UBS00P5E

Diagnostic Procedure

1. CHECK GROUND CONNECTIONS

1. Turn ignition switch OFF.
2. Loosen and retighten three ground screws on the body. Refer to [EC-158, "Ground Inspection"](#).

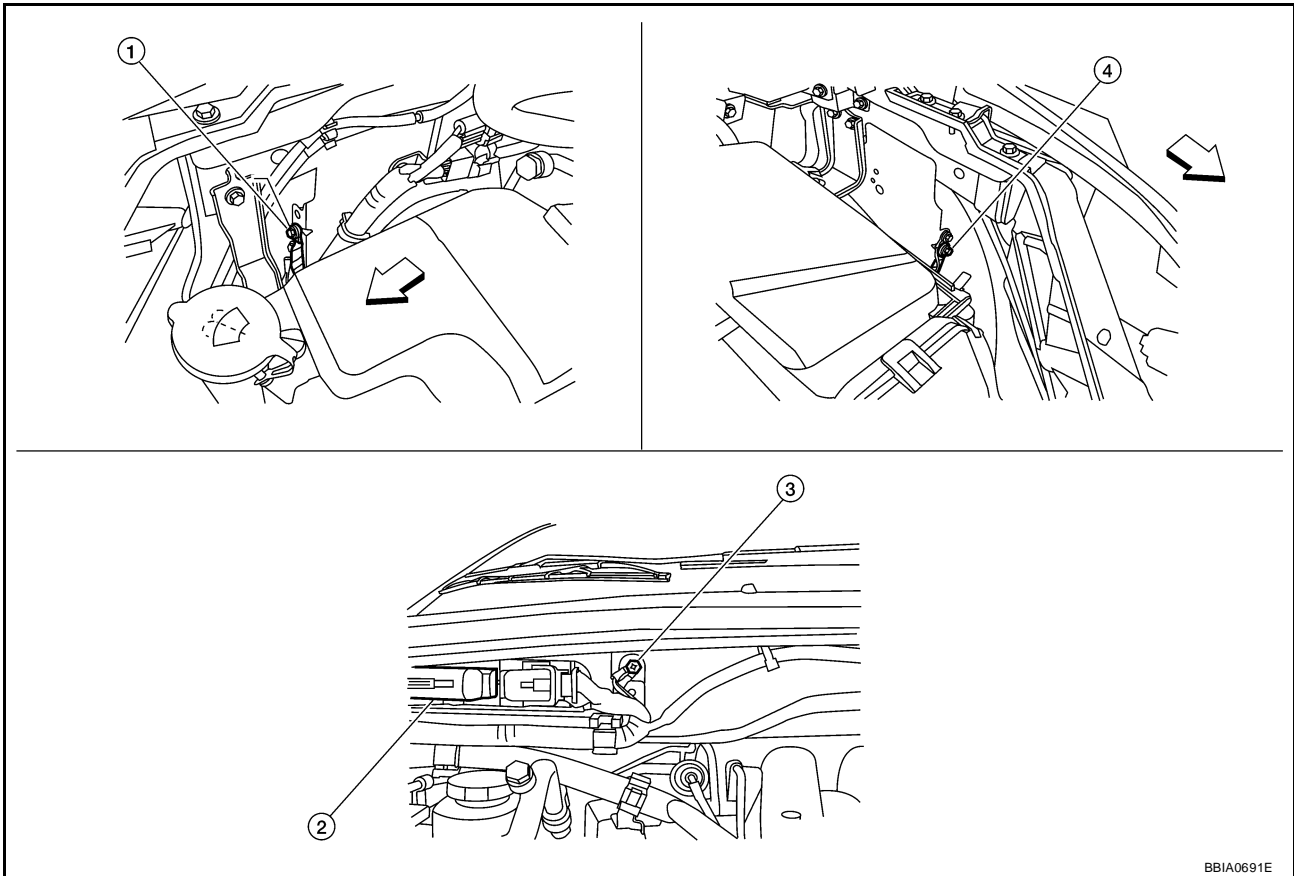

BBA0691E

← Vehicle front

1. Body ground E24

2. ECM

3. Body ground E9

4. Body ground E15

OK or NG

OK >> GO TO 2.

NG >> Repair or replace ground connections.

DTC P0132, P0152 A/F SENSOR 1

2. CHECK AIR FUEL RATIO (A/F) SENSOR 1 POWER SUPPLY CIRCUIT

1. Disconnect air fuel ratio (A/F) sensor 1 harness connector.

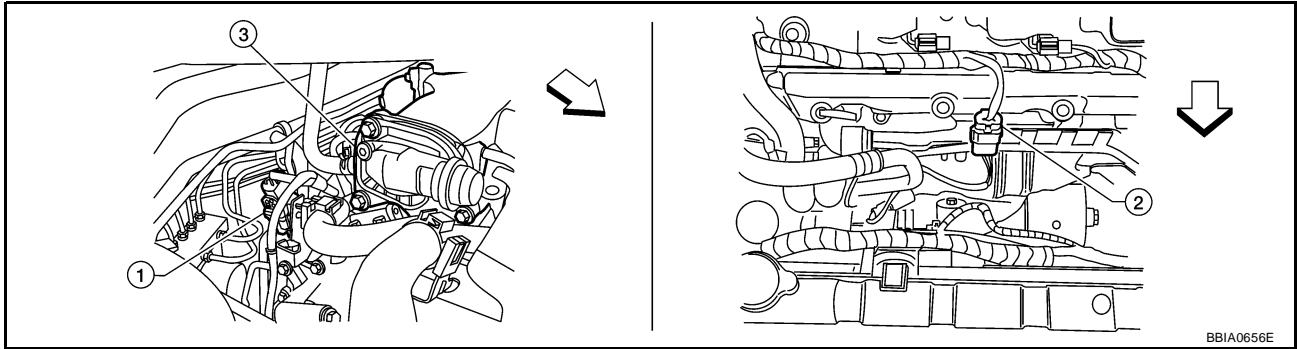

← Vehicle front

1. Air fuel ratio (A/F) sensor 1 (bank 1) harness connector
2. Air fuel ratio (A/F) sensor 1 (bank 2) harness connector
3. Intake manifold collector harness connector

2. Turn ignition switch ON.
3. Check voltage between A/F sensor 1 terminal 3 and ground with CONSULT-II or tester.

Voltage: Battery voltage

OK or NG

- OK >> GO TO 4.
- NG >> GO TO 3.

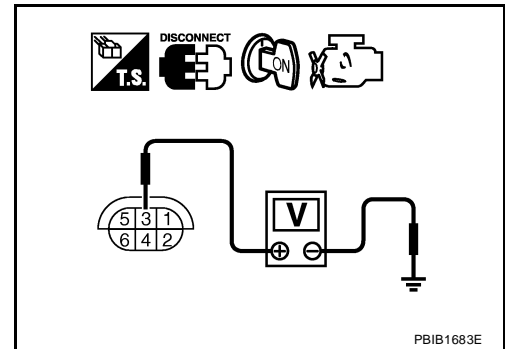

3. DETECT MALFUNCTIONING PART

Check the following.

- Harness connectors E5, F14
- IPDM E/R harness connector E122
- 15A fuse
- Harness for open or short between A/F sensor 1 and fuse

>> Repair or replace harness or connectors.

DTC P0132, P0152 A/F SENSOR 1

4. CHECK A/F SENSOR 1 INPUT SIGNAL CIRCUIT FOR OPEN AND SHORT

1. Turn ignition switch OFF.
2. Disconnect ECM harness connector.
3. Check harness continuity between the following terminals.
Refer to Wiring Diagram.

	A/F sensor 1 terminal	ECM terminal
Bank 1	1	16
	2	75
	5	35
	6	56
Bank 2	1	76
	2	77
	5	57
	6	58

Continuity should exist.

4. Check harness continuity between the following terminals and ground.
Refer to Wiring Diagram.

Bank 1		Bank 2	
A/F sensor 1 terminal	ECM terminal	A/F sensor 1 terminal	ECM terminal
1	16	1	76
2	75	2	77
5	35	5	57
6	56	6	58

Continuity should not exist.

5. Also check harness for short to power.

OK or NG

OK >> GO TO 5.

NG >> Repair open circuit or short to ground or short to power in harness or connectors.

5. CHECK INTERMITTENT INCIDENT

Perform [EC-149, "TROUBLE DIAGNOSIS FOR INTERMITTENT INCIDENT"](#) .

OK or NG

OK >> GO TO 6.

NG >> Repair or replace.

6. REPLACE AIR FUEL RATIO (A/F) SENSOR 1

Replace malfunctioning air fuel ratio (A/F) sensor 1.

CAUTION:

- Discard any air fuel ratio (A/F) sensor which has been dropped from a height of more than 0.5 m (19.7 in) onto a hard surface such as a concrete floor; use a new one.
- Before installing new air fuel ratio (A/F) sensor, clean exhaust system threads using Heated Oxygen Sensor Thread Cleaner tool J-43897-18 or J-43897-12 and approved anti-seize lubricant.

>> INSPECTION END

DTC P0132, P0152 A/F SENSOR 1

Removal and Installation AIR FUEL RATIO (A/F) SENSOR 1

UBS00P5F

Refer to [EM-26, "EXHAUST MANIFOLD AND THREE WAY CATALYST"](#) .

A

EC

C

D

E

F

G

H

I

J

K

L

M

DTC P0133, P0153 A/F SENSOR 1

DTC P0133, P0153 A/F SENSOR 1

PFP:22693

Component Description

UBS00P5G

The A/F sensor is a planar dual-cell limit current sensor. The sensor element of the A/F sensor is the combination of a Nernst concentration cell (sensor cell) with an oxygen-pump cell, which transports ions. It has a heater in the element.

The sensor is capable of precise measurement $\lambda = 1$, but also in the lean and rich range. Together with its control electronics, the sensor outputs a clear, continuous signal throughout a wide λ range ($0.7 < \lambda < \text{air}$).

The exhaust gas components diffuse through the diffusion gap at the electrode of the oxygen pump and Nernst concentration cell, where they are brought to thermodynamic balance.

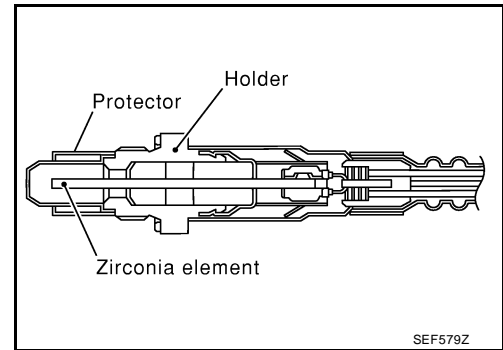

SEF579Z

An electronic circuit controls the pump current through the oxygen-pump cell so that the composition of the exhaust gas in the diffusion gap remains constant at $\lambda = 1$. Therefore, the A/F sensor is able to indicate air/fuel ratio by this pumping of current. In addition, a heater is integrated in the sensor to ensure the required operating temperature of 700 - 800°C (1,292 - 1,472°F).

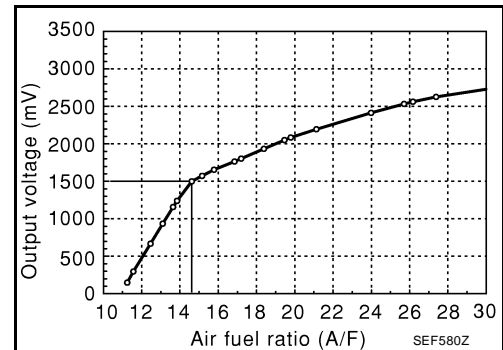

SEF580Z

CONSULT-II Reference Value in Data Monitor Mode

UBS00P5H

Specification data are reference values.

MONITOR ITEM	CONDITION	SPECIFICATION
A/F SEN1 (B1) A/F SEN1 (B2)	● Engine: After warming up Maintaining engine speed at 2,000 rpm	Fluctuates around 1.5V

On Board Diagnosis Logic

UBS00P5I

To judge the malfunction of air fuel ratio (A/F) sensor 1, this diagnosis measures response time of the A/F signal computed by ECM from the air fuel ratio (A/F) sensor 1 signal. The time is compensated by engine operating (speed and load), fuel feedback control constant, and the air fuel ratio (A/F) sensor 1 temperature index. Judgment is based on whether the compensated time (the A/F signal cycling time index) is inordinately long or not.

DTC No.	Trouble diagnosis name	DTC detecting condition	Possible Cause
P0133 0133 (Bank 1)	Air fuel ratio (A/F) sensor 1 circuit slow response	● The response of the A/F signal computed by ECM from A/F sensor 1 signal takes more than the specified time.	<ul style="list-style-type: none"> ● Harness or connectors (The A/F sensor 1 circuit is open or shorted.) ● Air fuel ratio (A/F) sensor 1 ● Air fuel ratio (A/F) sensor 1 heater ● Fuel pressure ● Fuel injector ● Intake air leaks ● Exhaust gas leaks ● PCV ● Mass air flow sensor
P0153 0153 (Bank 2)			

DTC P0133, P0153 A/F SENSOR 1

UBS00P5J

DTC Confirmation Procedure

NOTE:

If DTC Confirmation Procedure has been previously conducted, always turn ignition switch OFF and wait at least 10 seconds before conducting the next test.

TESTING CONDITION:

Before performing the following procedure, confirm that battery voltage is more than 11V at idle.

WITH CONSULT-II

1. Start engine and warm it up to normal operating temperature.
2. Turn ignition switch OFF and wait at least 10 seconds.
3. Start engine and keep the engine speed between 3,500 and 4,000 rpm for at least 1 minute under no load.
4. Let engine idle for 1 minute.
5. Select "A/F SEN1(B1) P1278/P1279" (for DTC P0133) or "A/F SEN1(B1) P1288/P1289" (for DTC P0153) of "A/F SEN1" in "DTC WORK SUPPORT" mode with CONSULT-II.

6. Touch "START".

If "COMPLETED" appears on CONSULT-II screen, go to step 10.

If "COMPLETED" does not appear on CONSULT-II screen, go to the following step.

A/F SEN1 (B1) P1278/P1279	
OUT OF CONDITION	
MONITOR	
ENG SPEED	XXX rpm
B/FUEL SCHDL	XXX msec
COOLAN TEMP/S	XXX °C
VHCL SPEED SE	XXX km/h

PBIB0756E

7. After perform the following procedure, "TESTING" will be displayed on the CONSULT-II screen.

a. Increase the engine speed up to 4,000 to 5,000 rpm and keep it for 10 seconds.

b. Fully release accelerator pedal and then let engine idle for about 10 seconds.

If "TESTING" is not displayed after 10 seconds, refer to [EC-139, "TROUBLE DIAGNOSIS - SPECIFICATION VALUE"](#) .

8. Wait for about 20 seconds at idle at under the condition that "TESTING" is displayed on the CONSULT-II screen.

A/F SEN1 (B1) P1278/P1279	
TESTING	
MONITOR	
ENG SPEED	XXX rpm
B/FUEL SCHDL	XXX msec
COOLAN TEMP/S	XXX °C
VHCL SPEED SE	XXX km/h

PBIB1925E

9. Make sure that "TESTING" changes to "COMPLETED".

If "TESTING" changed to "OUT OF CONDITION", refer to [EC-139, "TROUBLE DIAGNOSIS - SPECIFICATION VALUE"](#) .

10. Make sure that "OK" is displayed after touching "SELF-DIAG RESULT".

If "NG" is displayed, go to [EC-277, "Diagnostic Procedure"](#) .

A/F SEN1 (B1) P1278/P1279	
COMPLETED	

PBIB0758E

DTC P0133, P0153 A/F SENSOR 1



WITH GST

1. Start engine and warm it up to normal operating temperature.
2. Select Service \$01 with GST.
3. Calculate the total value of “Short term fuel trim” and “Long term fuel trim” indications.
Make sure that the total percentage should be within $\pm 15\%$.
If OK, go to the following step.
If NG, check the following.
 - Intake air leaks
 - Exhaust gas leaks
 - Incorrect fuel pressure
 - Lack of fuel
 - Fuel injectors
 - Incorrect PCV hose connection
 - PCV valve
 - Mass air flow sensor
4. Turn ignition switch OFF and wait at least 10 seconds.
5. Start engine and keep the engine speed between 3,500 and 4,000 rpm for at least 1 minute under no load.
6. Let engine idle for 1 minute.
7. Increase the engine speed up to 4,000 to 5,000 rpm and keep it for 10 seconds.
8. Fully release accelerator pedal and then let engine idle for about 1 minute.
9. Select Service \$07 with GST.
If 1st trip DTC is detected, go to [EC-277, "Diagnostic Procedure"](#) .

DTC P0133, P0153 A/F SENSOR 1

Wiring Diagram BANK 1

UBS00P5K

EC-AF1B1-01

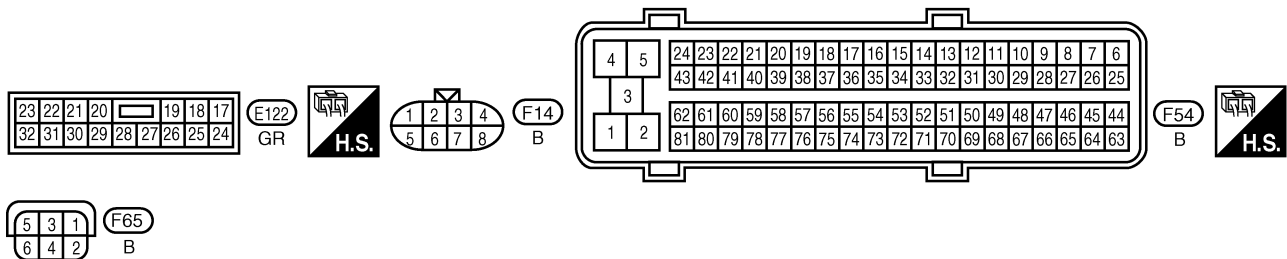
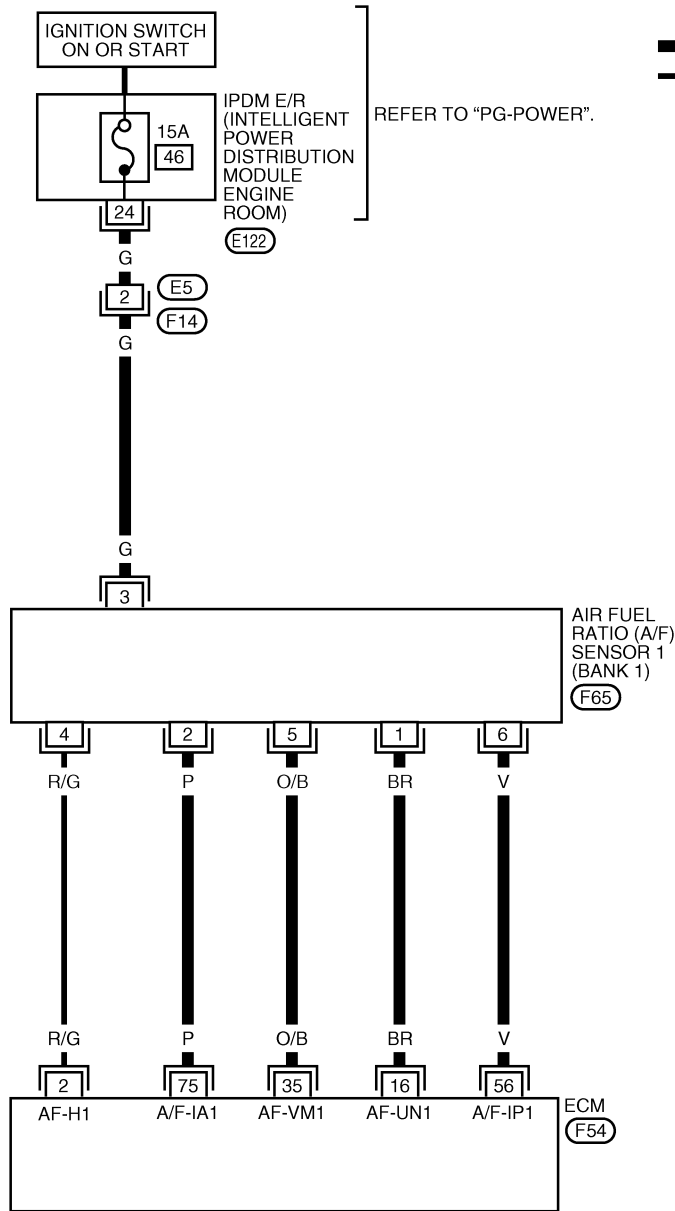

DTC P0133, P0153 A/F SENSOR 1

Specification data are reference values and are measured between each terminal and ground.
Pulse signal is measured by CONSULT-II.

CAUTION:

Do not use ECM ground terminals when measuring input/output voltage. Doing so may result in damage to the ECM's transistor. Use a ground other than ECM terminals, such as the ground.

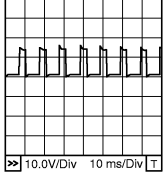
TERMI- NAL NO.	WIRE COLOR	ITEM	CONDITION	DATA (DC Voltage)
2	R/G	A/F sensor 1 heater (Bank 1)	[Engine is running] <ul style="list-style-type: none"> ● Warm-up condition ● Idle speed 	Approximately 5V★ 
16	BR	A/F sensor 1 (Bank 1)	[Engine is running] <ul style="list-style-type: none"> ● Warm-up condition ● Idle speed 	Approximately 3.1V
35	O/B			Approximately 2.6V
56	V			Approximately 2.3V
75	P			Approximately 2.3V

★: Average voltage for pulse signal (Actual pulse signal can be confirmed by oscilloscope.)

DTC P0133, P0153 A/F SENSOR 1

BANK 2

EC-AF1B2-01

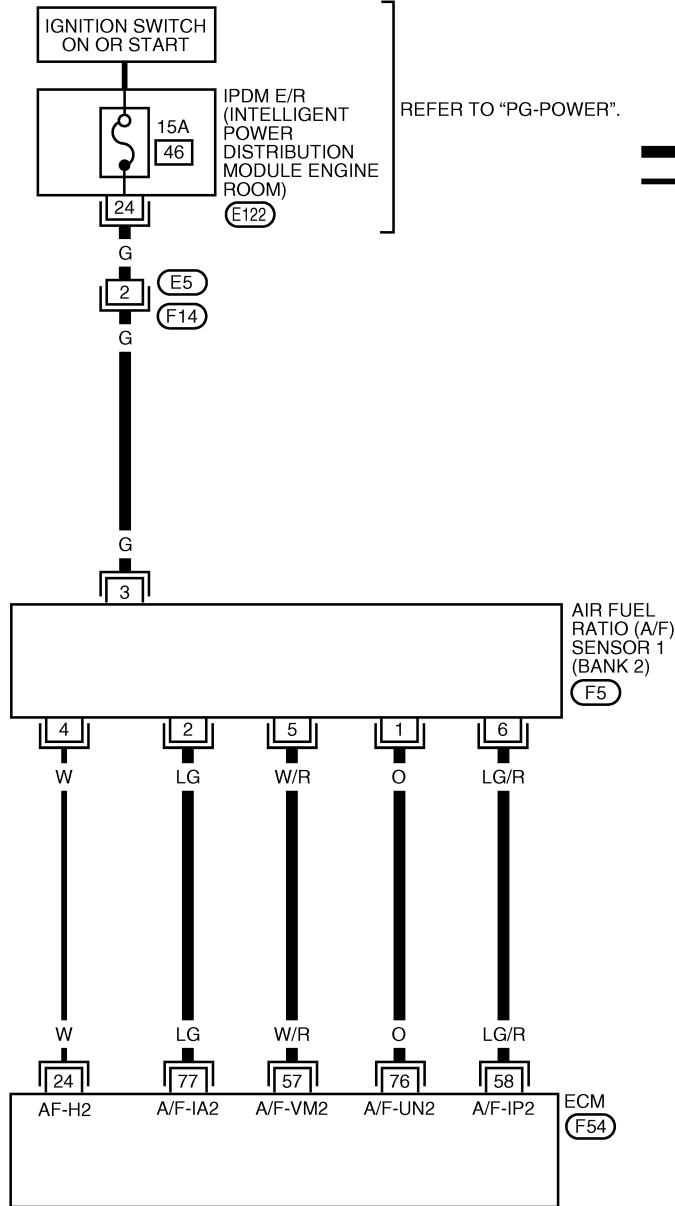

— : DETECTABLE LINE FOR DTC
 — : NON-DETECTABLE LINE FOR DTC

REFER TO "PG-POWER".

A
 EC
 C
 D
 E
 F
 G
 H
 I
 J
 K
 L
 M

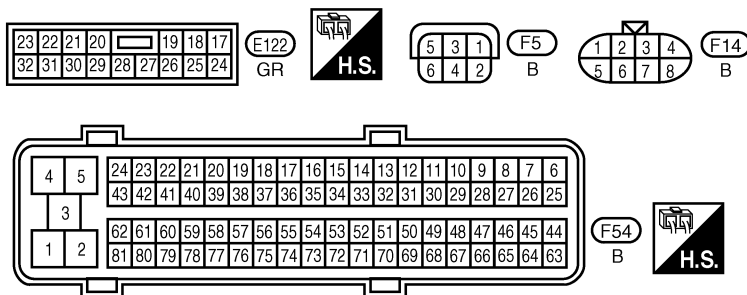

BBWA2504E

DTC P0133, P0153 A/F SENSOR 1

Specification data are reference values and are measured between each terminal and ground.
Pulse signal is measured by CONSULT-II.

CAUTION:

Do not use ECM ground terminals when measuring input/output voltage. Doing so may result in damage to the ECM's transistor. Use a ground other than ECM terminals, such as the ground.

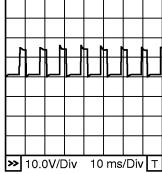
TERMI- NAL NO.	WIRE COLOR	ITEM	CONDITION	DATA (DC Voltage)
24	W	A/F sensor 1 heater (Bank 2)	[Engine is running] <ul style="list-style-type: none"> ● Warm-up condition ● Idle speed 	Approximately 5V★ 
57	W/R	A/F sensor 1 (Bank 2)	[Engine is running] <ul style="list-style-type: none"> ● Warm-up condition ● Idle speed 	Approximately 2.6V
58	LG/R			Approximately 2.3V
76	O			Approximately 3.1V
77	LG			Approximately 2.3V

★: Average voltage for pulse signal (Actual pulse signal can be confirmed by oscilloscope.)

DTC P0133, P0153 A/F SENSOR 1

UBS00P5L

Diagnostic Procedure

1. CHECK GROUND CONNECTIONS

1. Turn ignition switch OFF.
2. Loosen and retighten three ground screws on the body. Refer to [EC-158, "Ground Inspection"](#).

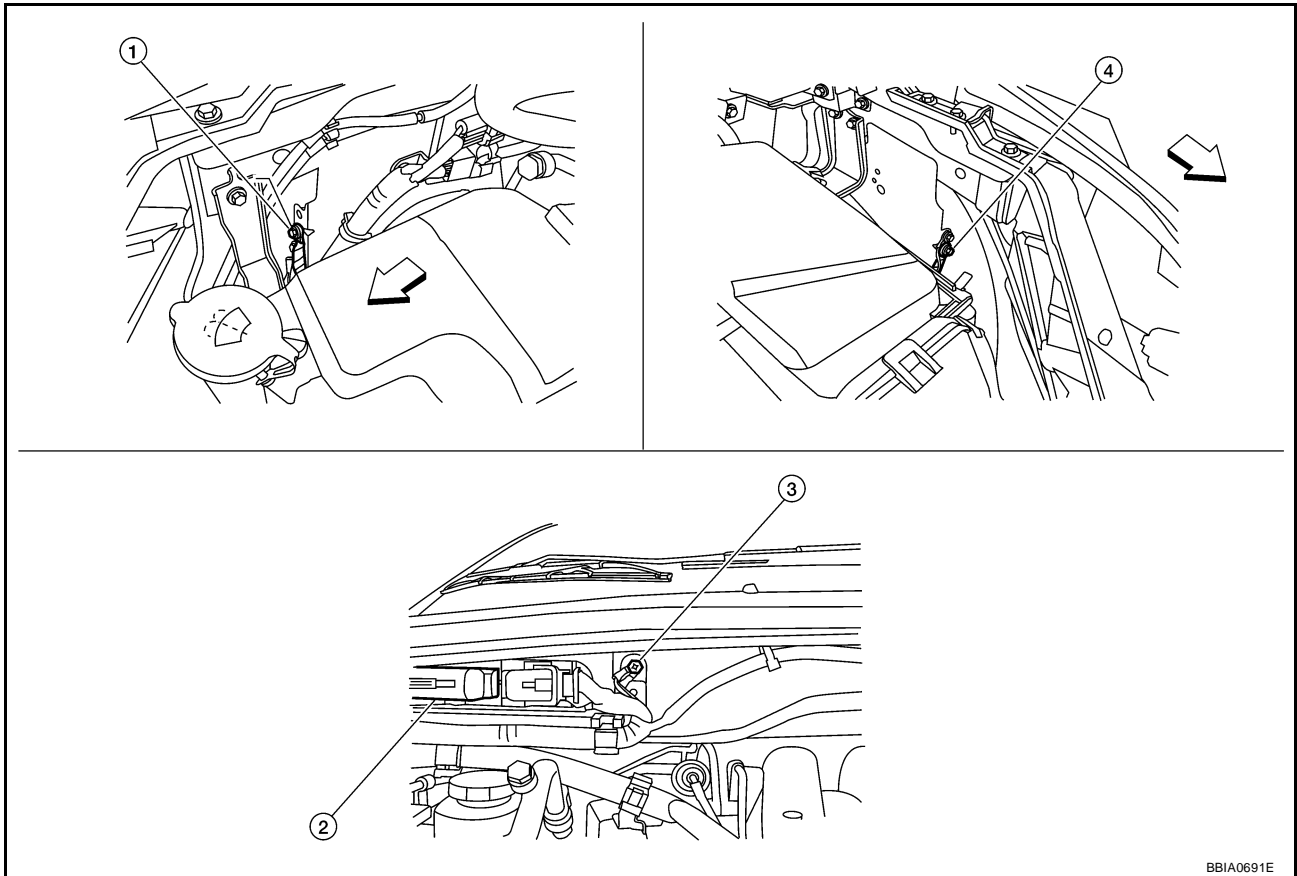

↔ Vehicle front

1. Body ground E24

2. ECM

3. Body ground E9

4. Body ground E15

OK or NG

OK >> GO TO 2.

NG >> Repair or replace ground connections.

DTC P0133, P0153 A/F SENSOR 1

2. RETIGHTEN AIR FUEL RATIO (A/F) SENSOR 1

Loosen and retighten the air fuel ratio (A/F) sensor 1.

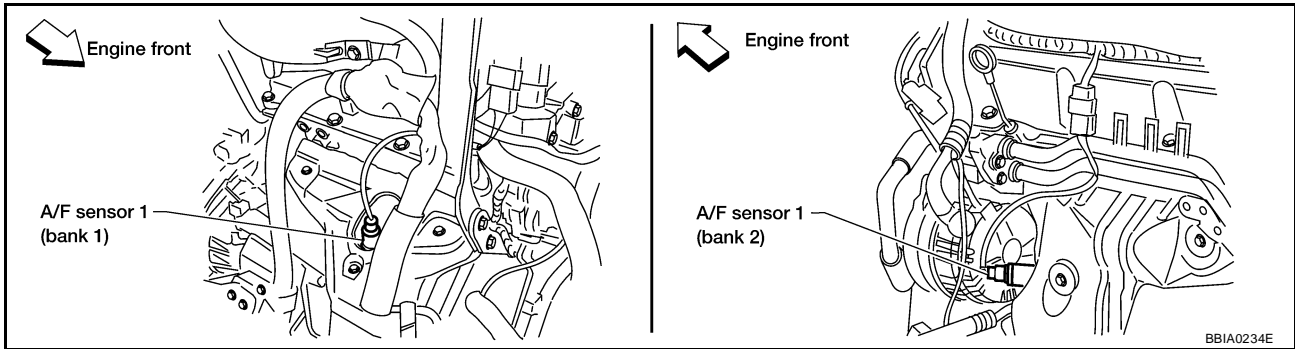

Tightening torque: 50 N-m (5.1 kg-m, 37 ft-lb)

>> GO TO 3.

3. CHECK EXHAUST GAS LEAK

1. Start engine and run it at idle.
2. Listen for an exhaust gas leak before three way catalyst (manifold).

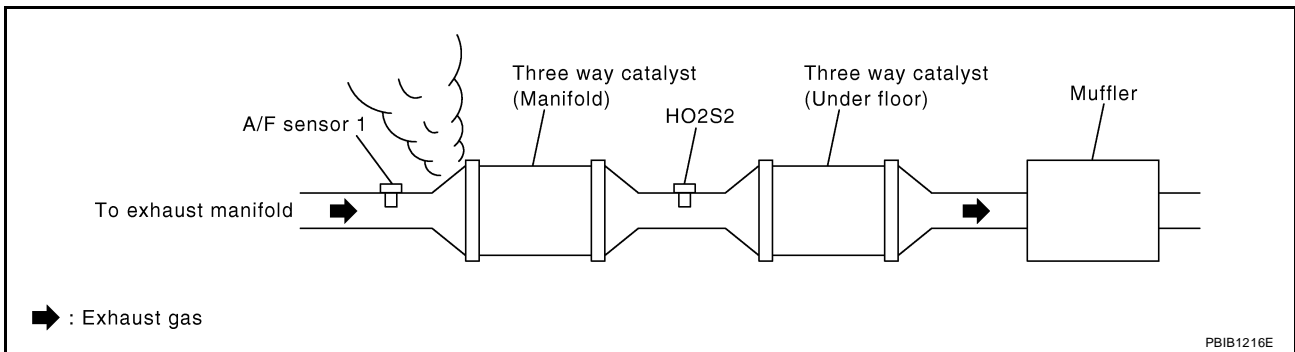

OK or NG

- OK >> GO TO 4.
- NG >> Repair or replace.

4. CHECK FOR INTAKE AIR LEAK

Listen for an intake air leak after the mass air flow sensor.

OK or NG

- OK >> GO TO 5.
- NG >> Repair or replace.

DTC P0133, P0153 A/F SENSOR 1

5. CLEAR THE SELF-LEARNING DATA

With CONSULT-II

1. Start engine and warm it up to normal operating temperature.
2. Select "SELF-LEARNING CONT" in "WORK SUPPORT" mode with CONSULT-II.
3. Clear the self-learning control coefficient by touching "CLEAR" or "START".
4. Run engine for at least 10 minutes at idle speed.
**Is the 1st trip DTC P0171, P172, P0174 or P0175 detected?
Is it difficult to start engine?**

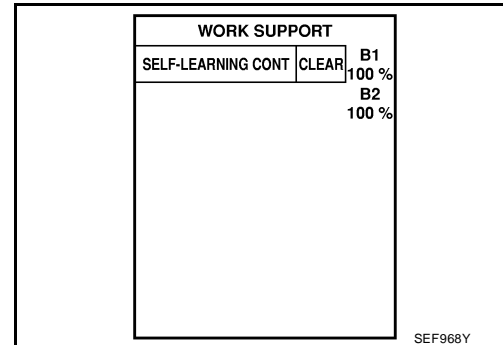

Without CONSULT-II

1. Start engine and warm it up to normal operating temperature.
2. Turn ignition switch OFF.
3. Disconnect mass air flow sensor harness connector.
4. Restart engine and let it idle for at least 5 seconds.
5. Stop engine and reconnect mass air flow sensor harness connector.
6. Make sure DTC P0102 is displayed.
7. Erase the DTC memory. Refer to [EC-63, "HOW TO ERASE EMISSION-RELATED DIAGNOSTIC INFORMATION"](#) .
8. Make sure DTC P0000 is displayed.
9. Run engine for at least 10 minutes at idle speed.
**Is the 1st trip DTC P0171, P0172, P0174 or P0175 detected?
Is it difficult to start engine?**

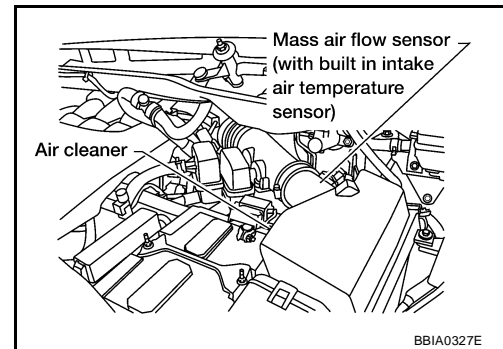

Yes or No

- Yes >> Perform trouble diagnosis for DTC P0171, P0174 or P0172, P0175. Refer to [EC-322](#) or [EC-334](#) .
- No >> GO TO 6.

DTC P0133, P0153 A/F SENSOR 1

6. CHECK AIR FUEL RATIO (A/F) SENSOR 1 POWER SUPPLY CIRCUIT

1. Turn ignition switch OFF.
2. Disconnect air fuel ratio (A/F) sensor 1 harness connector.

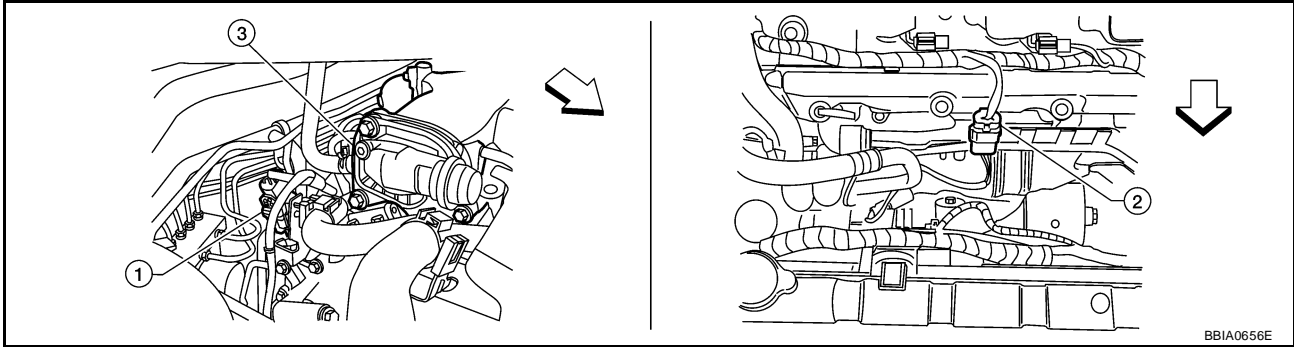

← Vehicle front

1. Air fuel ratio (A/F) sensor 1 (bank 1) harness connector
2. Air fuel ratio (A/F) sensor 1 (bank 2) harness connector
3. Intake manifold collector harness connector

3. Turn ignition switch ON.
4. Check voltage between A/F sensor 1 terminal 3 and ground with CONSULT-II or tester.

Voltage: Battery voltage

OK or NG

- OK >> GO TO 8.
NG >> GO TO 7.

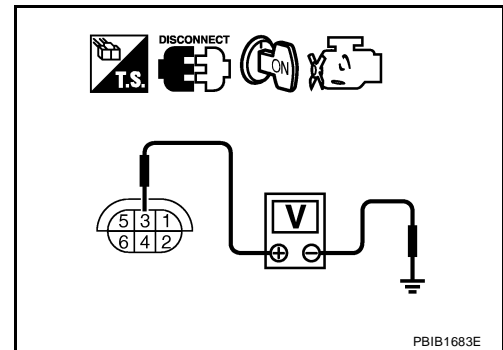

7. DETECT MALFUNCTIONING PART

Check the following.

- Harness connectors E5, F14
- IPDM E/R harness connector E122
- 15A fuse
- Harness for open or short between A/F sensor 1 and fuse

>> Repair or replace harness or connectors.

DTC P0133, P0153 A/F SENSOR 1

8. CHECK A/F SENSOR 1 INPUT SIGNAL CIRCUIT FOR OPEN AND SHORT

1. Turn ignition switch OFF.
2. Disconnect ECM harness connector.
3. Check harness continuity between the following terminals.
Refer to Wiring Diagram.

	A/F sensor 1 terminal	ECM terminal
Bank1	1	16
	2	75
	5	35
	6	56
Bank 2	1	76
	2	77
	5	57
	6	58

Continuity should exist.

4. Check harness continuity between the following terminals and ground.
Refer to Wiring Diagram.

Bank 1		Bank 2	
A/F sensor 1 terminal	ECM terminal	A/F sensor 1 terminal	ECM terminal
1	16	1	76
2	75	2	77
5	35	5	57
6	56	6	58

Continuity should not exist.

5. Also check harness for short to power.

OK or NG

OK >> GO TO 9.

NG >> Repair open circuit or short to ground or short to power in harness or connectors.

9. CHECK AIR FUEL RATIO (A/F) SENSOR 1 HEATER

Refer to [EC-175, "Component Inspection"](#) .

OK or NG

OK >> GO TO 10.

NG >> GO TO 13.

10. CHECK MASS AIR FLOW SENSOR

Refer to [EC-200, "Component Inspection"](#) .

OK or NG

OK >> GO TO 11.

NG >> Replace mass air flow sensor.

DTC P0133, P0153 A/F SENSOR 1

11. CHECK PCV VALVE

Refer to [EC-45, "POSITIVE CRANKCASE VENTILATION"](#) .

OK or NG

OK >> GO TO 12.

NG >> Repair or replace PCV valve.

12. CHECK INTERMITTENT INCIDENT

Perform [EC-149, "TROUBLE DIAGNOSIS FOR INTERMITTENT INCIDENT"](#) .

OK or NG

OK >> GO TO 13.

NG >> Repair or replace.

13. REPLACE AIR FUEL RATIO (A/F) SENSOR 1

Replace malfunctioning air fuel ratio (A/F) sensor 1.

CAUTION:

- Discard any air fuel ratio (A/F) sensor which has been dropped from a height of more than 0.5 m (19.7 in) onto a hard surface such as a concrete floor; use a new one.
- Before installing new air fuel ratio (A/F) sensor, clean exhaust system threads using Heated Oxygen Sensor Thread Cleaner tool J-43897-18 or J-43897-12 and approved anti-seize lubricant.

>> INSPECTION END

Removal and Installation AIR FUEL RATIO (A/F) SENSOR 1

UBS00P5M

Refer to [EM-26, "EXHAUST MANIFOLD AND THREE WAY CATALYST"](#) .

DTC P0137, P0157 HO2S2

DTC P0137, P0157 HO2S2

PF2:226A0

Component Description

UBS00P5N

The heated oxygen sensor 2, after three way catalyst (manifold), monitors the oxygen level in the exhaust gas on each bank.

Even if switching characteristics of the A/F sensor 1 are shifted, the air-fuel ratio is controlled to stoichiometric, by the signal from the heated oxygen sensor 2.

This sensor is made of ceramic zirconia. The zirconia generates voltage from approximately 1V in richer conditions to 0V in leaner conditions.

Under normal conditions the heated oxygen sensor 2 is not used for engine control operation.

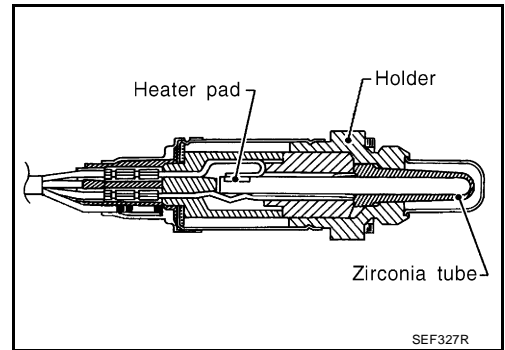

CONSULT-II Reference Value in Data Monitor Mode

UBS00P50

Specification data are reference values.

MONITOR ITEM	CONDITION	SPECIFICATION
HO2S2 (B1) HO2S2 (B2)	<ul style="list-style-type: none"> ● Revving engine from idle to 3,000 rpm quickly after the following conditions are met – Engine: After warming up 	0 - 0.3V ↔ Approx. 0.6 - 1.0V
HO2S2 MNTR (B1) HO2S2 MNTR (B2)	<ul style="list-style-type: none"> – Keeping the engine speed between 3,500 and 4,000 rpm for 1 minute and at idle for 1 minute under no load 	LEAN ↔ RICH

On Board Diagnosis Logic

UBS00P5P

The heated oxygen sensor 2 has a much longer switching time between rich and lean than the heated oxygen sensor 1. The oxygen storage capacity of the three way catalyst (manifold) causes the longer switching time. To judge the malfunctions of heated oxygen sensor 2, ECM monitors whether the maximum voltage of the sensor is sufficiently high during the various driving condition such as fuel-cut.

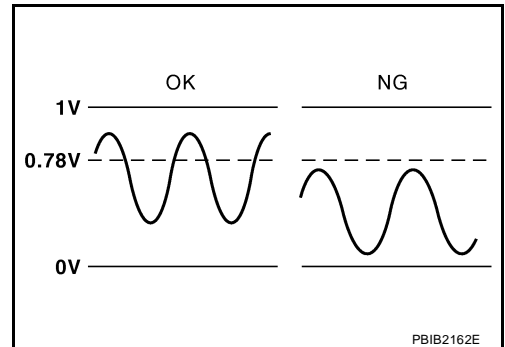

DTC No.	Trouble diagnosis name	DTC detecting condition	Possible cause
P0137 0137 (Bank 1)	Heated oxygen sensor 2 circuit low voltage	The maximum voltage from the sensor is not reached to the specified voltage.	<ul style="list-style-type: none"> ● Harness or connectors (The sensor circuit is open or shorted)
P0157 0157 (Bank 2)			<ul style="list-style-type: none"> ● Heated oxygen sensor 2 ● Fuel pressure ● Fuel injector ● Intake air leaks

DTC P0137, P0157 HO2S2

UBS00P5Q

DTC Confirmation Procedure

NOTE:

If DTC confirmation Procedure has been previously conducted, always turn ignition switch OFF and wait at least 10 seconds before conducting the next test.

Ⓜ WITH CONSULT-II

TESTING CONDITION:

For better results, perform "DTC WORK SUPPORT" at a temperature of 0 to 30 °C (32 to 86 °F).

1. Turn ignition switch ON and select "DATA MONITOR" mode with CONSULT-II.
2. Start engine and warm it up to the normal operating temperature.
3. Turn ignition switch OFF and wait at least 10 seconds.
4. Start engine and keep the engine speed between 3,500 and 4,000 rpm for at least 1 minute under no load.
5. Let engine idle for 1 minute.
6. Make sure that "COOLAN TEMP/S" indicates more than 70°C (158°F).
If not, warm up engine and go to next step when "COOLAN TEMP/S" indication reaches to 70°C (158°F).
7. Open engine hood.
8. Select "HO2S2 (B1) P1147" (for DTC P0137) or "HO2S2 (B2) P1167" (for DTC P0157) of "HO2S2" in "DTC WORK SUPPORT" mode with CONSULT-II.
9. Start engine and following the instruction of CONSULT-II.

DATA MONITOR	
MONITOR	NO DTC
ENG SPEED	XXX rpm
COOLAN TEMP/S	XXX °C

SEF174Y

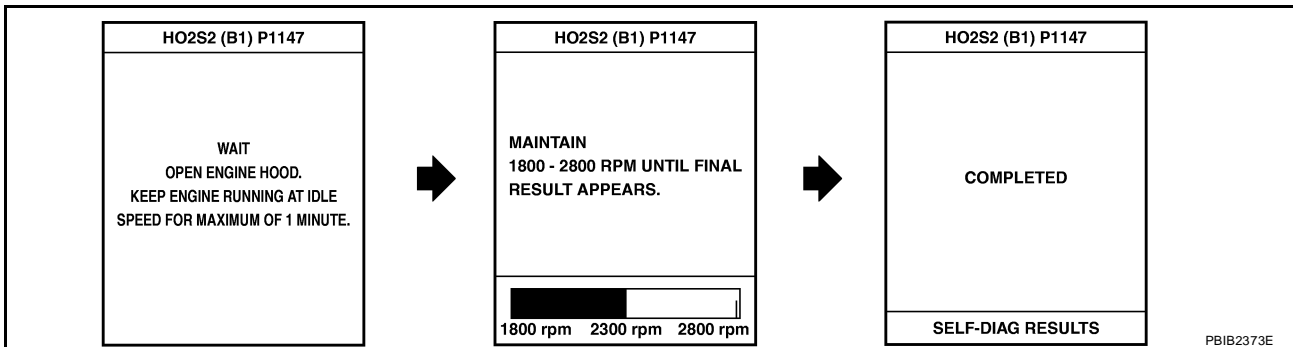

NOTE:

It will take at most 10 minutes until "COMPLETED" is displayed.

10. Make sure that "OK" is displayed after touching "SELF-DIAG RESULTS".
If "NG" is displayed, refer to [EC-290, "Diagnostic Procedure"](#).
If "CAN NOT BE DIAGNOSED" is displayed, perform the following.
 - a. Turn ignition switch OFF and leave the vehicle in a cool place (soak the vehicle).
 - b. Return to step 1.

Overall Function Check

UBS00P5R

Use this procedure to check the overall function of the heated oxygen sensor 2 circuit. During this check, a 1st trip DTC might not be confirmed.

Ⓜ WITH GST

1. Start engine and warm it up to the normal operating temperature.
2. Turn ignition switch OFF and wait at least 10 seconds.
3. Start engine and keep the engine speed between 3,500 and 4,000 rpm for at least 1 minute under no load.
4. Let engine idle for 1 minute.
5. Set voltmeter probes between ECM terminal 74 [HO2S2 (B1) signal] or 55 [HO2S2 (B2) signal] and ground.

DTC P0137, P0157 HO2S2

6. Check the voltage when revving up to 4,000 rpm under no load at least 10 times.
(Depress and release accelerator pedal as soon as possible.)
The voltage should be above 0.78V at least once during this procedure.
If the voltage can be confirmed in step 6, step 7 is not necessary.
7. Keep vehicle at idling for 10 minutes, then check the voltage.
Or check the voltage when coasting from 80 km/h (50 MPH) in D position with "OD" OFF.
The voltage should be above 0.78V at least once during this procedure.
8. If NG, go to [EC-290, "Diagnostic Procedure"](#) .

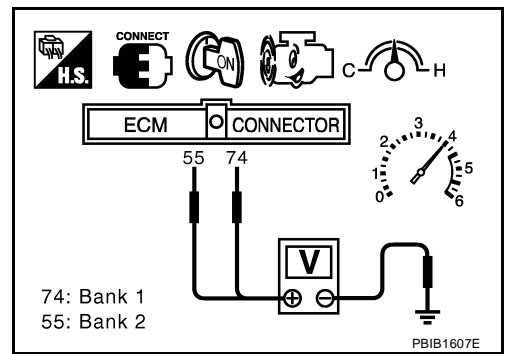

A

EC

C

D

E

F

G

H

I

J

K

L

M

DTC P0137, P0157 HO2S2

UBS00P5S

Wiring Diagram BANK 1

EC-O2S2B1-01

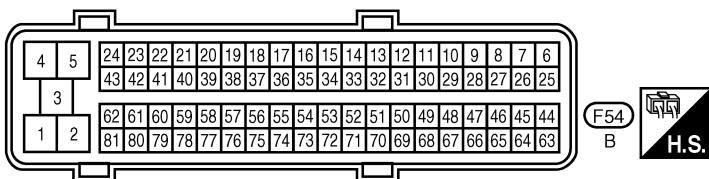
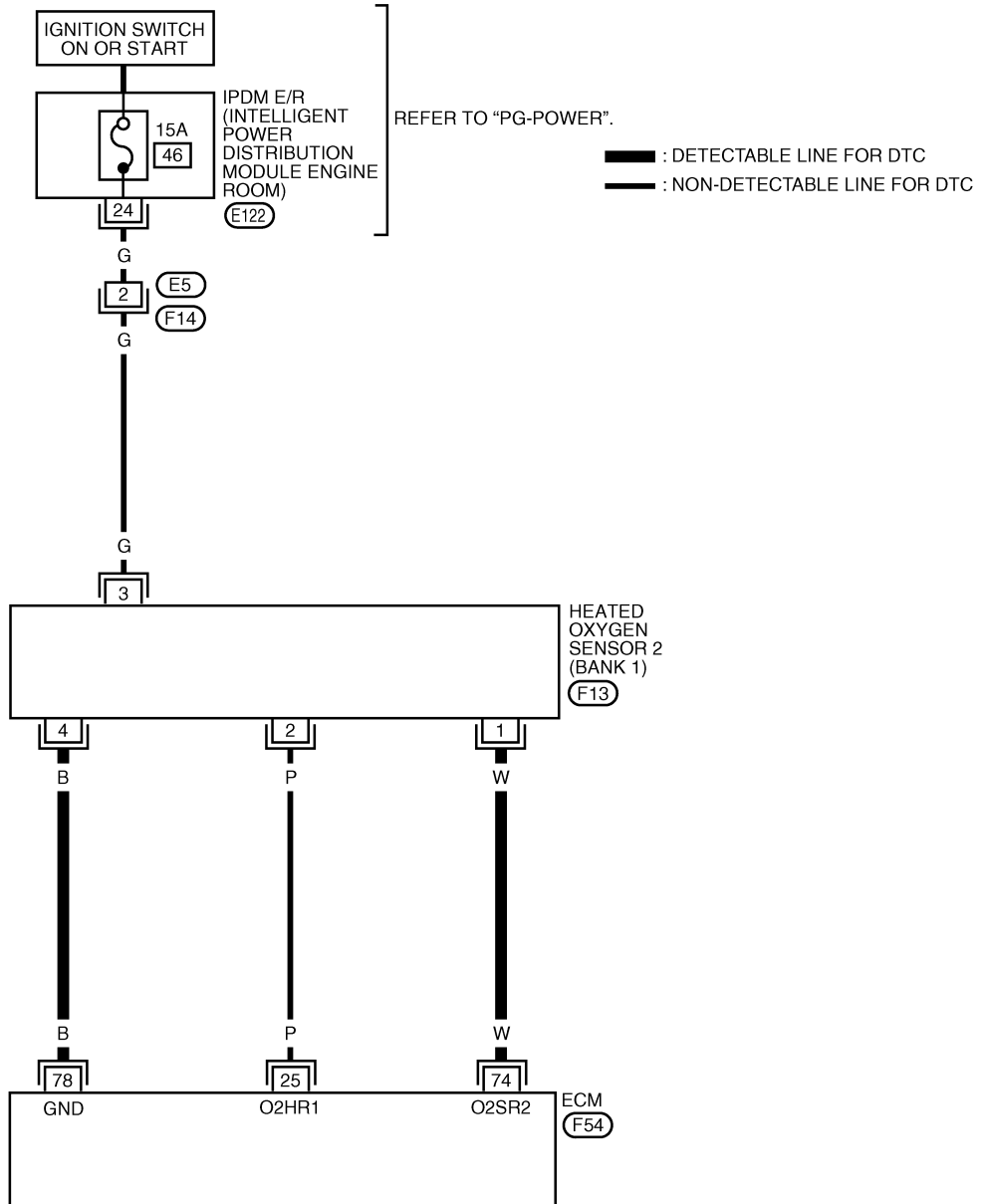

BBWA2509E

DTC P0137, P0157 HO2S2

Specification data are reference values and are measured between each terminal and ground.

CAUTION:

Do not use ECM ground terminals when measuring input/output voltage. Doing so may result in damage to the ECM's transistor. Use a ground other than ECM terminals, such as the ground.

TER-MINAL NO.	WIRE COLOR	ITEM	CONDITION	DATA (DC Voltage)
25	P	Heated oxygen sensor 2 heater (Bank 1)	[Engine is running] <ul style="list-style-type: none"> ● Engine speed: Below 3,600 rpm after the following conditions are met <ul style="list-style-type: none"> – Engine: After warming up – Keeping the engine speed between 3,500 and 4,000 rpm for 1 minute and at idle for 1 minute under no load. 	0 - 1.0V
			[Ignition switch: ON] <ul style="list-style-type: none"> ● Engine stopped [Engine is running] <ul style="list-style-type: none"> ● Engine speed: Above 3,600 rpm 	BATTERY VOLTAGE (11 - 14V)
74	W	Heated oxygen sensor 2 (Bank 1)	[Engine is running] <ul style="list-style-type: none"> ● Revving engine from idle to 3,000 rpm quickly after the following conditions are met <ul style="list-style-type: none"> – Engine: After warming up – Keeping the engine speed between 3,500 and 4,000 rpm for 1 minute and at idle for 1 minute under no load 	0 - Approximately 1.0V
78	B	Heated oxygen sensor 2 ground	[Engine is running] <ul style="list-style-type: none"> ● Warm-up condition ● Idle speed 	Approximately 0V

A
EC
C
D
E
F
G
H
I
J
K
L
M

DTC P0137, P0157 HO2S2

BANK 2

EC-O2S2B2-01

: DETECTABLE LINE FOR DTC
 : NON-DETECTABLE LINE FOR DTC

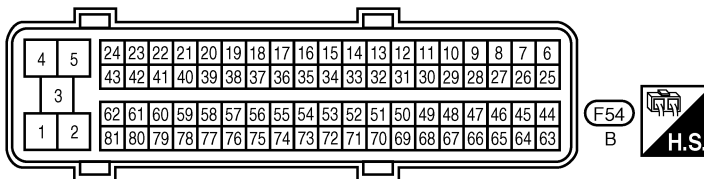
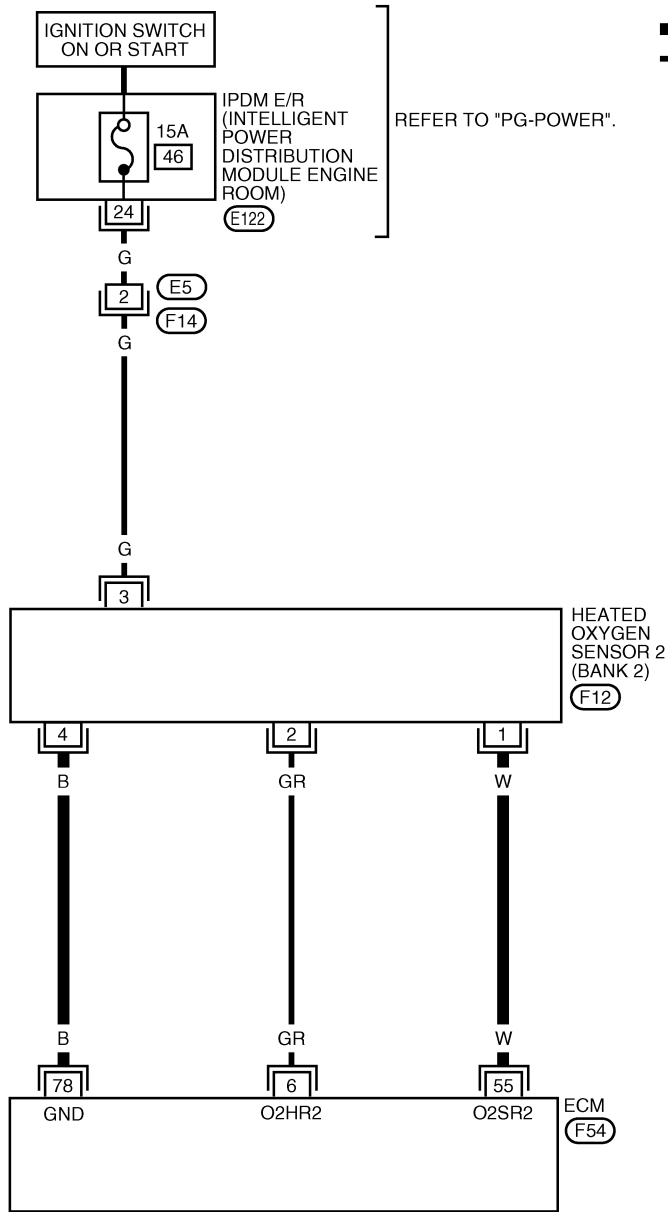

BBWA2510E

DTC P0137, P0157 HO2S2

Specification data are reference values and are measured between each terminal and ground.

CAUTION:

Do not use ECM ground terminals when measuring input/output voltage. Doing so may result in damage to the ECM's transistor. Use a ground other than ECM terminals, such as the ground.

TER-MINAL NO.	WIRE COLOR	ITEM	CONDITION	DATA (DC Voltage)
6	GR	Heated oxygen sensor 2 heater (Bank 2)	[Engine is running] <ul style="list-style-type: none"> ● Engine speed: Below 3,600 rpm after the following conditions are met <ul style="list-style-type: none"> – Engine: After warming up – Keeping the engine speed between 3,500 and 4,000 rpm for 1 minute and at idle for 1 minute under no load. 	0 - 1.0V
			[Ignition switch: ON] <ul style="list-style-type: none"> ● Engine stopped [Engine is running] <ul style="list-style-type: none"> ● Engine speed: Above 3,600 rpm 	BATTERY VOLTAGE (11 - 14V)
55	W	Heated oxygen sensor 2 (Bank 2)	[Engine is running] <ul style="list-style-type: none"> ● Revving engine from idle to 3,000 rpm quickly after the following conditions are met <ul style="list-style-type: none"> – Engine: After warming up – Keeping the engine speed between 3,500 and 4,000 rpm for 1 minute and at idle for 1 minute under no load 	0 - Approximately 1.0V
78	B	Heated oxygen sensor 2 ground	[Engine is running] <ul style="list-style-type: none"> ● Warm-up condition ● Idle speed 	Approximately 0V

A
EC
C
D
E
F
G
H
I
J
K
L
M

DTC P0137, P0157 HO2S2

UBS00P5T

Diagnostic Procedure

1. CHECK GROUND CONNECTIONS

1. Turn ignition switch OFF.
2. Loosen and retighten three ground screws on the body. Refer to [EC-158, "Ground Inspection"](#).

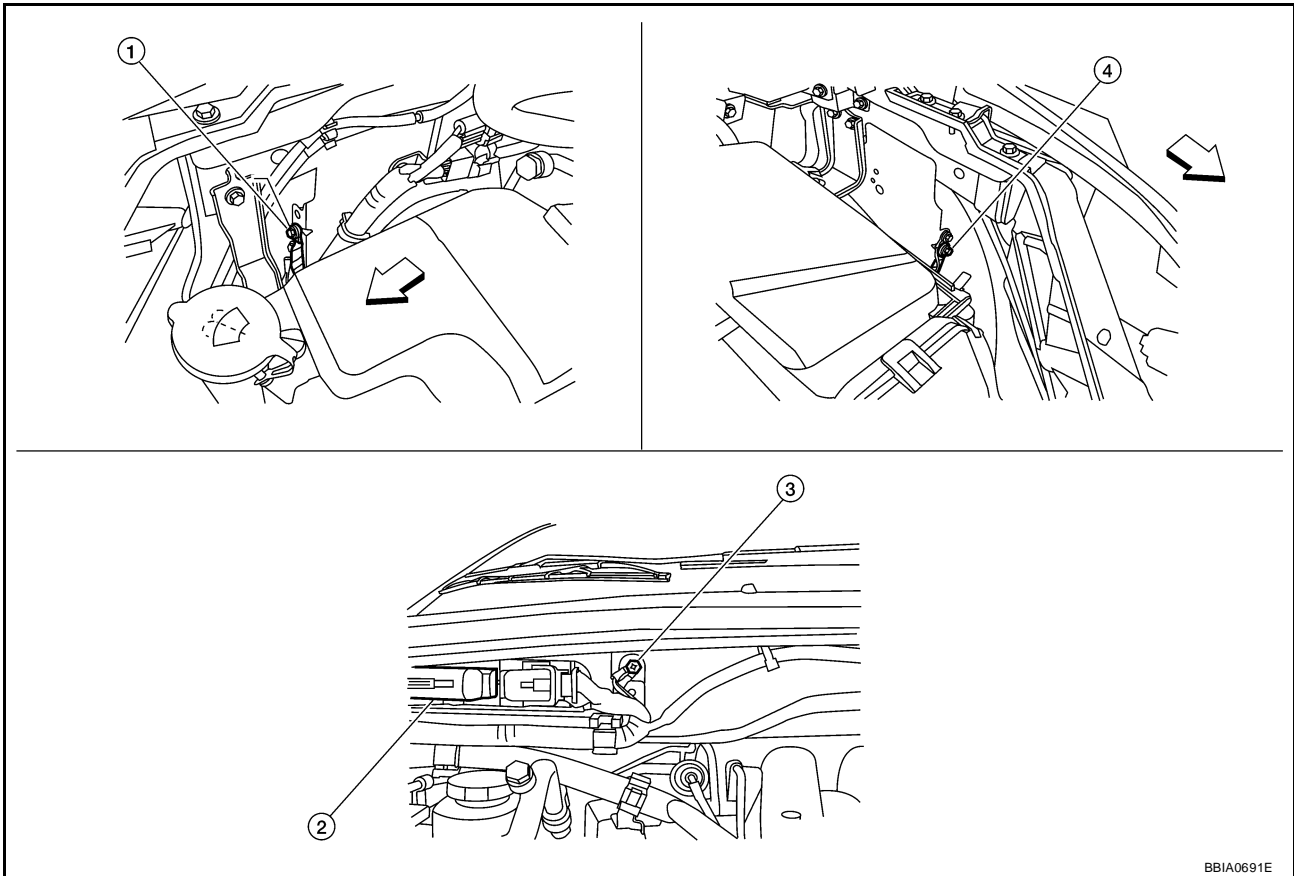

BBA0691E

← Vehicle front

1. Body ground E24

2. ECM

3. Body ground E9

4. Body ground E15

OK or NG

OK >> GO TO 2.

NG >> Repair or replace ground connections.

2. CLEAR THE SELF-LEARNING DATA

With CONSULT-II

1. Start engine and warm it up to normal operating temperature.
2. Select "SELF-LEARNING CONT" in "WORK SUPPORT" mode with CONSULT-II.
3. Clear the self-learning control coefficient by touching "CLEAR".
4. Run engine for at least 10 minutes at idle speed.
**Is the 1st trip DTC P0171 or P0174 detected?
Is it difficult to start engine?**

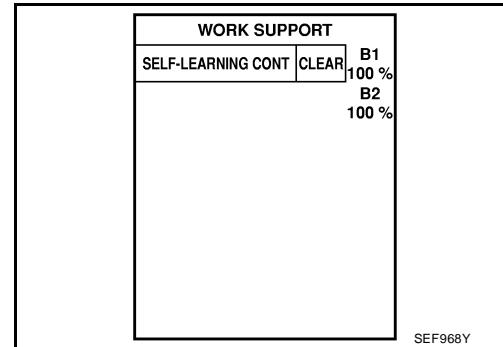

Without CONSULT-II

1. Start engine and warm it up to normal operating temperature.
2. Turn ignition switch OFF.
3. Disconnect mass air flow sensor harness connector.
4. Restart and let it idle for at least 5 seconds.
5. Stop engine and reconnect mass air flow sensor harness connector.
6. Make sure DTC P0102 is displayed.
7. Erase the DTC memory. Refer to [EC-63, "HOW TO ERASE EMISSION-RELATED DIAGNOSTIC INFORMATION"](#).
8. Make sure DTC P0000 is displayed.
9. Run engine for at least 10 minutes at idle speed.
**Is the 1st trip DTC P0171 or P0174 detected?
Is it difficult to start engine?**

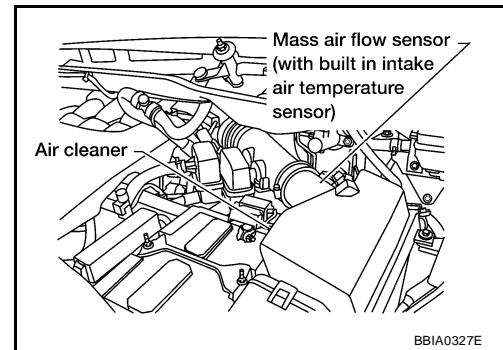

Yes or No

- Yes >> Perform trouble diagnosis for DTC P0171, P0174. Refer to [EC-322](#).
- No >> GO TO 3.

3. CHECK HO2S2 GROUND CIRCUIT FOR OPEN AND SHORT

1. Turn ignition switch OFF.
2. Disconnect ECM harness connector.
3. Disconnect heated oxygen sensor 2 harness connector.
 - Oil pan (1)
 - Heated oxygen sensor 2 (bank 2) harness connector (2)
 - Heated oxygen sensor 2 (bank 1) harness connector (3)
4. Check harness continuity between ECM terminal 78 and HO2S2 terminal 4.
Refer to Wiring Diagram.

Continuity should exist.

5. Also check harness for short to ground and short to power.

OK or NG

- OK >> GO TO 4.
- NG >> Repair open circuit or short to ground or short to power in harness or connectors.

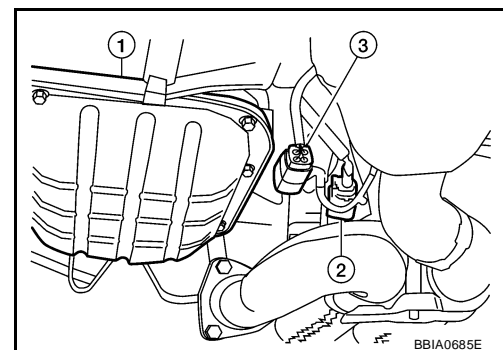

DTC P0137, P0157 HO2S2

4. CHECK HO2S2 INPUT SIGNAL CIRCUIT FOR OPEN AND SHORT

1. Check harness continuity between ECM terminal and HO2S2 terminal as follows.
Refer to Wiring Diagram.

DTC	Terminals		Bank
	ECM	Sensor	
P0137	74	1	1
P0157	55	1	2

Continuity should exist.

2. Check harness continuity between the following terminals and ground.
Refer to Wiring Diagram.

DTC	Terminals		Bank
	ECM	Sensor	
P0137	74	1	1
P0157	55	1	2

Continuity should not exist.

3. Also check harness for short to power.

OK or NG

OK >> GO TO 5.

NG >> Repair open circuit or short to ground or short to power in harness or connectors.

5. CHECK HEATED OXYGEN SENSOR 2

Refer to [EC-292, "Component Inspection"](#).

OK or NG

OK >> GO TO 6.

NG >> Replace malfunctioning heated oxygen sensor 2.

6. CHECK INTERMITTENT INCIDENT

Refer to [EC-149, "TROUBLE DIAGNOSIS FOR INTERMITTENT INCIDENT"](#).

>> **INSPECTION END**

Component Inspection HEATED OXYGEN SENSOR 2

UBS00P5U

④ **With CONSULT-II**

1. Turn ignition switch ON and select "DATA MONITOR" mode with CONSULT-II.
2. Start engine and warm it up to the normal operating temperature.
3. Turn ignition switch OFF and wait at least 10 seconds.
4. Start engine and keep the engine speed between 3,500 and 4,000 rpm for at least 1 minute under no load.
5. Let engine idle for 1 minute.

DATA MONITOR	
MONITOR	NO DTC
ENG SPEED	XXX rpm
COOLANT TEMP/S	XXX °C

SEF174Y

DTC P0137, P0157 HO2S2

6. Select "FUEL INJECTION" in "ACTIVE TEST" mode, and select "HO2S2 (B1)/(B2)" as the monitor item with CONSULT-II.

ACTIVE TEST	
FUEL INJECTION	25 %
MONITOR	
ENG SPEED	XXX rpm
HO2S2 (B1)	XXX V
HO2S2 (B2)	XXX V

PBIB1672E

7. Check "HO2S2 (B1)/(B2)" at idle speed when adjusting "FUEL INJECTION" to $\pm 25\%$.

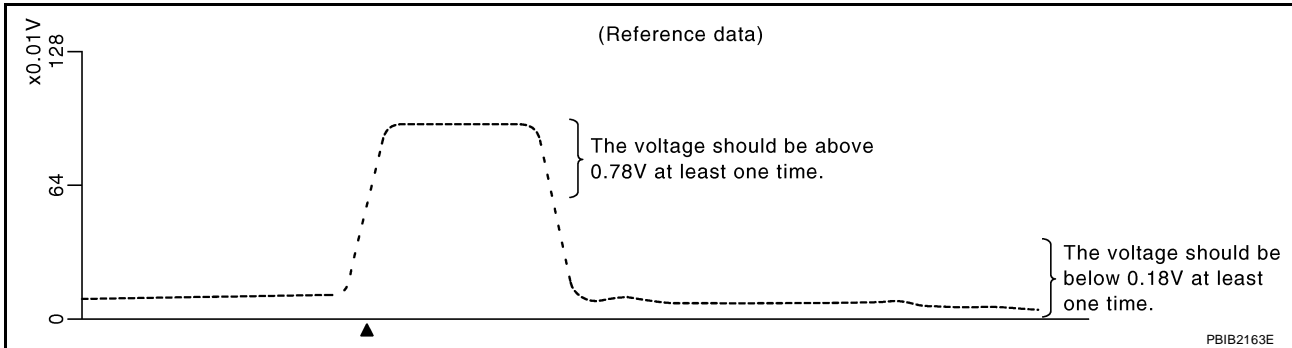

"HO2S2 (B1)/(B2)" should be above 0.78V at least once when the "FUEL INJECTION" is +25%.
 "HO2S2 (B1)/(B2)" should be below 0.18V at least once when the "FUEL INJECTION" is -25%.

CAUTION:

- Discard any heated oxygen sensor which has been dropped from a height of more than 0.5 m (19.7 in) onto a hard surface such as a concrete floor; use a new one.
- Before installing new oxygen sensor, clean exhaust system threads using Oxygen Sensor Thread Cleaner tool J-43897-18 or J-43897-12 and approved anti-seize lubricant.

⊗ Without CONSULT-II

1. Start engine and warm it up to the normal operating temperature.
2. Turn ignition switch OFF and wait at least 10 seconds.
3. Start engine and keep the engine speed between 3,500 and 4,000 rpm for at least 1 minute under no load.
4. Let engine idle for 1 minute.
5. Set voltmeter probes between ECM terminal 74 [HO2S2 (B1) signal] or 55 [HO2S2 (B2) signal] and ground.
6. Check the voltage when revving up to 4,000 rpm under no load at least 10 times.
 (Depress and release accelerator pedal as soon as possible.)
The voltage should be above 0.78V at least once during this procedure.
If the voltage is above 0.78V at step 6, step 7 is not necessary.
7. Keep vehicle at idling for 10 minutes, then check voltage.
 Or check the voltage when coasting from 80 km/h (50 MPH) in D position with "OD" OFF.
The voltage should be below 0.18V at least once during this procedure.
8. If NG, replace heated oxygen sensor 2.

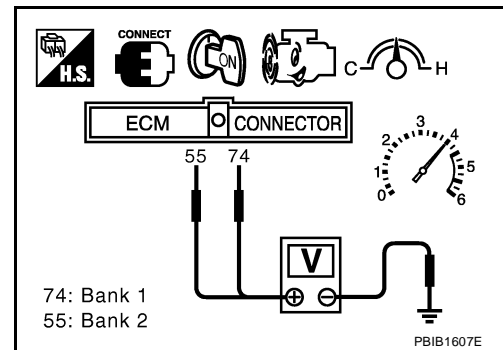

CAUTION:

- Discard any heated oxygen sensor which has been dropped from a height of more than 0.5 m (19.7 in) onto a hard surface such as a concrete floor; use a new one.
- Before installing new oxygen sensor, clean exhaust system threads using Oxygen Sensor Thread Cleaner tool J-43897-18 or J-43897-12 and approved anti-seize lubricant.

DTC P0137, P0157 HO2S2

Removal and Installation HEATED OXYGEN SENSOR 2

UBS00P5V

Refer to [EM-26, "EXHAUST MANIFOLD AND THREE WAY CATALYST"](#) .

DTC P0138, P0158 HO2S2

DTC P0138, P0158 HO2S2

PF2:226A0

Component Description

UBS00P5W

The heated oxygen sensor 2, after three way catalyst (manifold), monitors the oxygen level in the exhaust gas on each bank.

Even if switching characteristics of the air fuel ratio (A/F) sensor 1 are shifted, the air-fuel ratio is controlled to stoichiometric, by the signal from the heated oxygen sensor 2.

This sensor is made of ceramic zirconia. The zirconia generates voltage from approximately 1V in richer conditions to 0V in leaner conditions.

Under normal conditions the heated oxygen sensor 2 is not used for engine control operation.

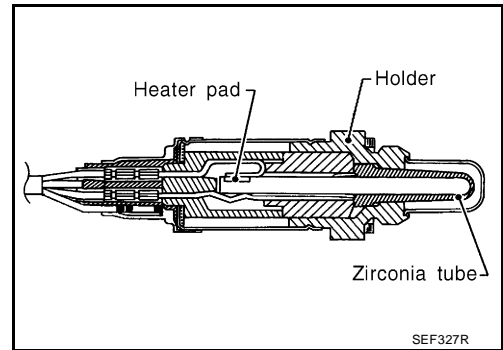

CONSULT-II Reference Value in Data Monitor Mode

UBS00P5X

Specification data are reference values.

MONITOR ITEM	CONDITION	SPECIFICATION
HO2S2 (B1) HO2S2 (B2)	<ul style="list-style-type: none"> ● Revving engine from idle to 3,000 rpm quickly after the following conditions are met - Engine: After warming up 	0 - 0.3V ↔ Approx. 0.6 - 1.0V
HO2S2 MNTR (B1) HO2S2 MNTR (B2)	<ul style="list-style-type: none"> - Keeping the engine speed between 3,500 and 4,000 rpm for 1 minute and at idle for 1 minute under no load 	LEAN ↔ RICH

On Board Diagnosis Logic

UBS00P5Y

The heated oxygen sensor 2 has a much longer switching time between rich and lean than the air fuel ratio (A/F) sensor 1. The oxygen storage capacity of the three way catalyst (manifold) causes the longer switching time.

MALFUNCTION A

To judge the malfunctions of heated oxygen sensor 2, ECM monitors whether the voltage is unusually high during the various driving condition such as fuel-cut.

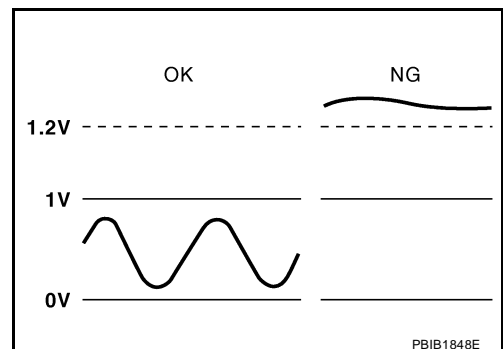

DTC P0138, P0158 HO2S2

MALFUNCTION B

To judge the malfunctions of heated oxygen sensor 2, ECM monitors whether the minimum voltage of sensor is sufficiently low during the various driving condition such as fuel-cut.

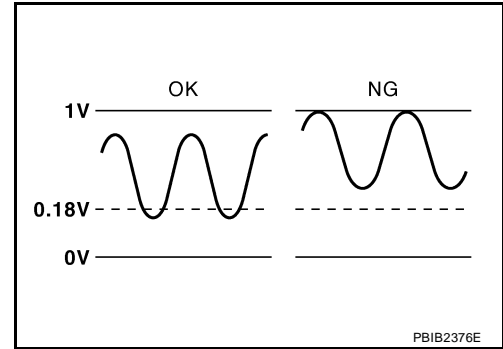

DTC No.	Trouble diagnosis name	DTC detecting condition		Possible cause
P0138 0138 (Bank 1)	Heated oxygen sensor 2 circuit high voltage	A)	An excessively high voltage from the sensor is sent to ECM.	<ul style="list-style-type: none"> ● Harness or connectors (The sensor circuit is open or shorted) ● Heated oxygen sensor 2
P0158 0158 (Bank 2)		B)	The minimum voltage from the sensor is not reached to the specified voltage.	<ul style="list-style-type: none"> ● Harness or connectors (The sensor circuit is open or shorted) ● Heated oxygen sensor 2 ● Fuel pressure ● Fuel injector

DTC Confirmation Procedure

UBS00P5Z

Perform **PROCEDURE FOR MALFUNCTION A** first.

If DTC cannot be confirmed, perform **PROCEDURE FOR MALFUNCTION B**.

NOTE:

If DTC Confirmation Procedure has been previously conducted, always turn ignition switch OFF and wait at least 10 seconds before conducting the next test.

PROCEDURE FOR MALFUNCTION A

④ With CONSULT-II

1. Turn ignition switch ON and select "DATA MONITOR" mode with CONSULT-II.
2. Start engine and warm it up to the normal operating temperature.
3. Turn ignition switch OFF and wait at least 10 seconds.
4. Start engine and keep the engine speed between 3,500 and 4,000 rpm for at least 1 minute under no load.
5. Let engine idle for 2 minutes.
6. If 1st trip DTC is detected, go to [EC-303, "PROCEDURE FOR MALFUNCTION A"](#).

DATA MONITOR	
MONITOR	NO DTC
ENG SPEED	XXX rpm
COOLANT TEMP/S	XXX °C

SEF174Y

④ With GST

Follow the procedure "With CONSULT-II" above.

DTC P0138, P0158 HO2S2

PROCEDURE FOR MALFUNCTION B

With CONSULT-II

TESTING CONDITION:

For better results, perform "DTC WORK SUPPORT" at a temperature of 0 to 30 °C (32 to 86 °F).

1. Turn ignition switch ON and select "DATA MONITOR" mode with CONSULT-II.
2. Start engine and warm it up to the normal operating temperature.
3. Turn ignition switch OFF and wait at least 10 seconds.
4. Start engine and keep the engine speed between 3,500 and 4,000 rpm for at least 1 minute under no load.
5. Let engine idle for 1 minute.
6. Make sure that "COOLAN TEMP/S" indicates more than 70°C (158°F).
If not, warm up engine and go to next step when "COOLAN TEMP/S" indication reaches to 70°C (158°F).

DATA MONITOR	
MONITOR	NO DTC
ENG SPEED	XXX rpm
COOLAN TEMP/S	XXX °C

SEF174Y

7. Open engine hood.
8. Select "HO2S2 (B1) P1146" (for DTC P0138) or "HO2S2 (B2) P1166" (for DTC P0158) of "HO2S2" in "DTC WORK SUPPORT" mode with CONSULT-II.
9. Start engine and following the instruction of CONSULT-II.

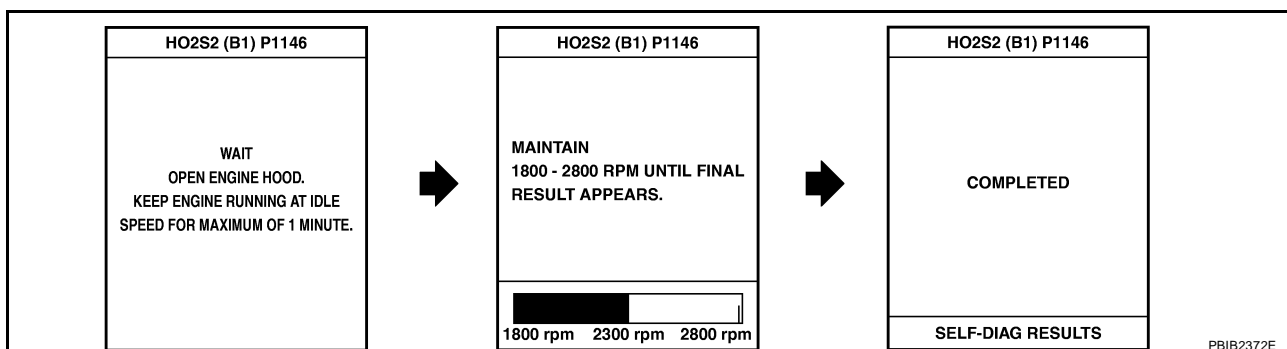

NOTE:

It will take at most 10 minutes until "COMPLETED" is displayed.

10. Make sure that "OK" is displayed after touching "SELF-DIAG RESULTS".
If "NG" is displayed, refer to [EC-305. "PROCEDURE FOR MALFUNCTION B"](#).
If "CAN NOT BE DIAGNOSED" is displayed, perform the following.
 - a. Turn ignition switch OFF and leave the vehicle in a cool place (soak the vehicle).
 - b. Return to step 1.

Overall Function Check PROCEDURE MALFUNCTION B

UBS00P60

Use this procedure to check the overall function of the heated oxygen sensor 2 circuit. During this check, a 1st trip DTC might not be confirmed.

With GST

1. Start engine and warm it up to the normal operating temperature.
2. Turn ignition switch OFF and wait at least 10 seconds.
3. Start engine and keep the engine speed between 3,500 and 4,000 rpm for at least 1 minute under no load.
4. Let engine idle for 1 minute.
5. Set voltmeter probes between ECM terminal 74 [HO2S2 (B1) signal] or 55 [HO2S2 (B2) signal] and ground.

DTC P0138, P0158 HO2S2

6. Check the voltage when revving up to 4,000 rpm under no load at least 10 times.
(Depress and release accelerator pedal as soon as possible.)
The voltage should be below 0.18V at least once during this procedure.
If the voltage can be confirmed in step 6, step 7 is not necessary.
7. Keep vehicle at idling for 10 minutes, then check the voltage.
Or check the voltage when coasting from 80 km/h (50 MPH) in D position with "OD" OFF.
The voltage should be below 0.18V at least once during this procedure.
8. If NG, go to [EC-305, "PROCEDURE FOR MALFUNCTION B"](#) .

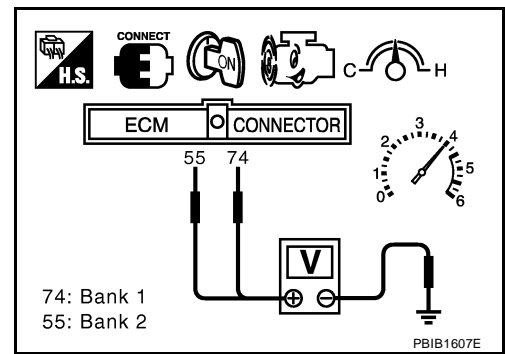

DTC P0138, P0158 HO2S2

UBS00P61

Wiring Diagram BANK 1

EC-O2S2B1-01

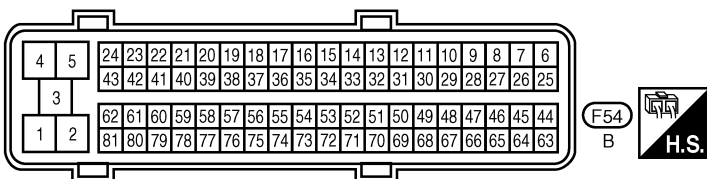
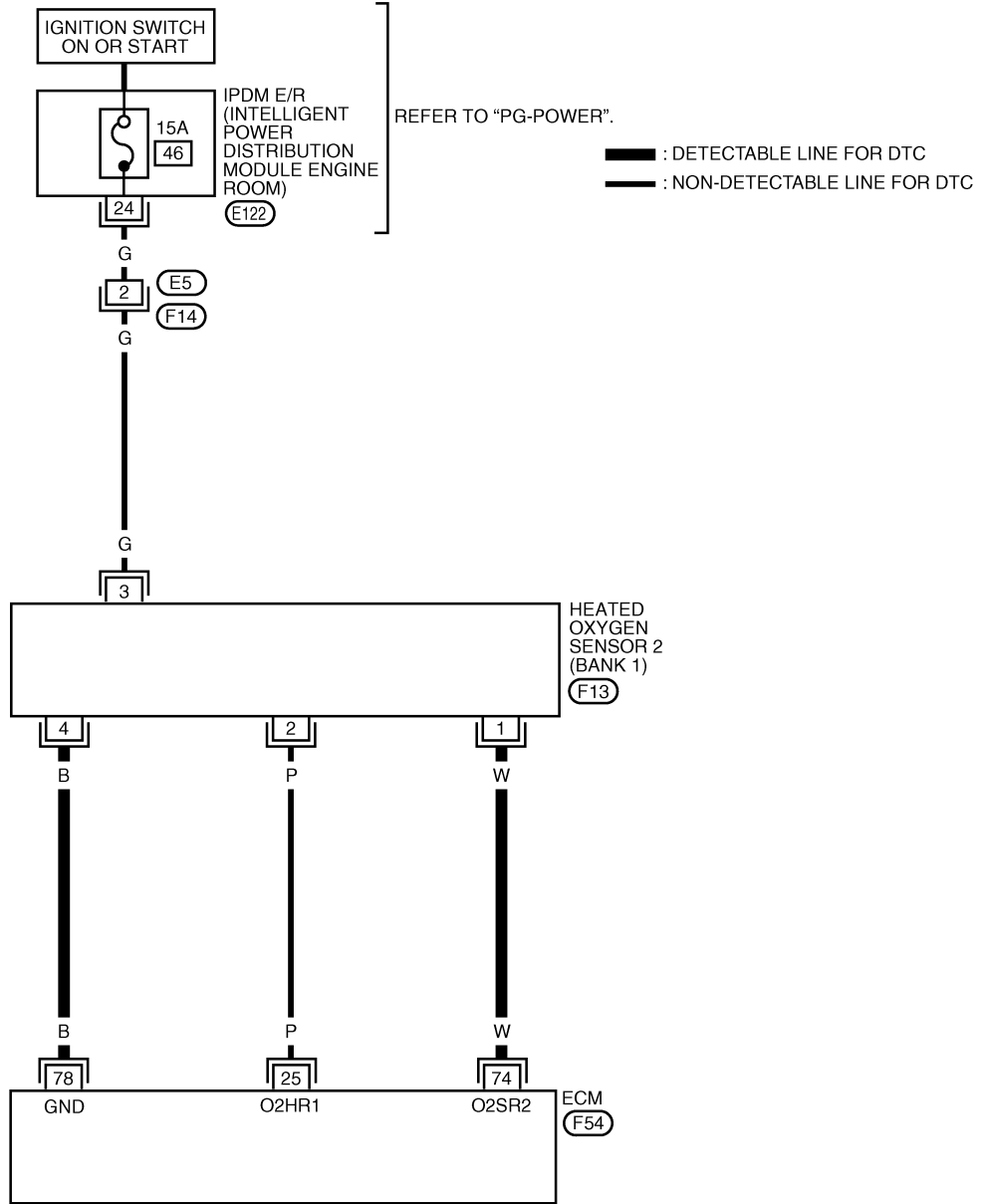

BBWA2509E

DTC P0138, P0158 HO2S2

Specification data are reference values and are measured between each terminal and ground.

CAUTION:

Do not use ECM ground terminals when measuring input/output voltage. Doing so may result in damage to the ECM's transistor. Use a ground other than ECM terminals, such as the ground.

TER-MINAL NO.	WIRE COLOR	ITEM	CONDITION	DATA (DC Voltage)
25	P	Heated oxygen sensor 2 heater (Bank 1)	[Engine is running] <ul style="list-style-type: none"> ● Engine speed: Below 3,600 rpm after the following conditions are met <ul style="list-style-type: none"> - Engine: After warming up - Keeping the engine speed between 3,500 and 4,000 rpm for 1 minute and at idle for 1 minute under no load. 	0 - 1.0V
			[Ignition switch: ON] <ul style="list-style-type: none"> ● Engine stopped [Engine is running] <ul style="list-style-type: none"> ● Engine speed: Above 3,600 rpm 	BATTERY VOLTAGE (11 - 14V)
74	W	Heated oxygen sensor 2 (Bank 1)	[Engine is running] <ul style="list-style-type: none"> ● Revving engine from idle to 3,000 rpm quickly after the following conditions are met <ul style="list-style-type: none"> - Engine: After warming up - Keeping the engine speed between 3,500 and 4,000 rpm for 1 minute and at idle for 1 minute under no load 	0 - Approximately 1.0V
78	B	Heated oxygen sensor 2 ground	[Engine is running] <ul style="list-style-type: none"> ● Warm-up condition ● Idle speed 	Approximately 0V

DTC P0138, P0158 HO2S2

BANK 2

EC-O2S2B2-01

: DETECTABLE LINE FOR DTC
 : NON-DETECTABLE LINE FOR DTC

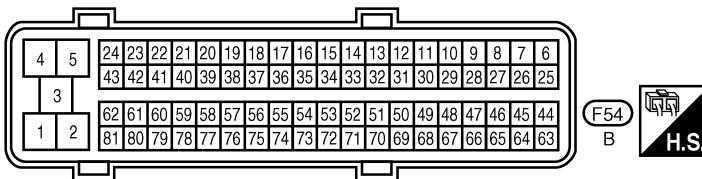
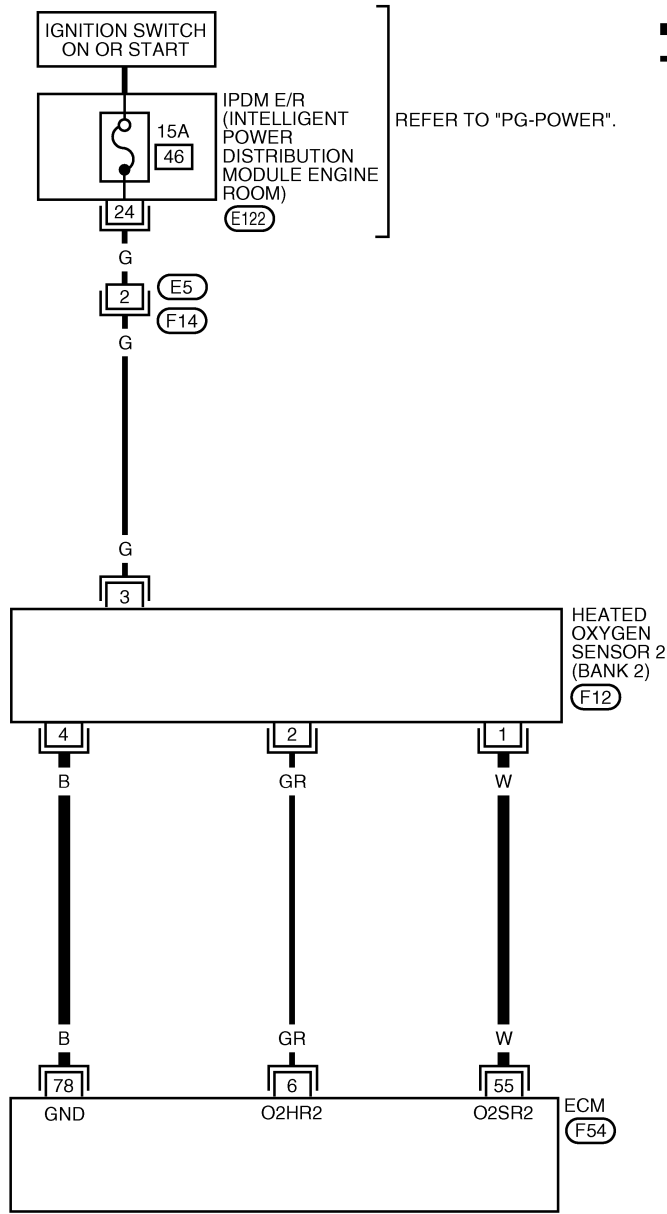

BBWA2510E

DTC P0138, P0158 HO2S2

Specification data are reference values and are measured between each terminal and ground.

CAUTION:

Do not use ECM ground terminals when measuring input/output voltage. Doing so may result in damage to the ECM's transistor. Use a ground other than ECM terminals, such as the ground.

TER-MINAL NO.	WIRE COLOR	ITEM	CONDITION	DATA (DC Voltage)
6	GR	Heated oxygen sensor 2 heater (Bank 2)	[Engine is running] <ul style="list-style-type: none"> ● Engine speed: Below 3,600 rpm after the following conditions are met <ul style="list-style-type: none"> - Engine: After warming up - Keeping the engine speed between 3,500 and 4,000 rpm for 1 minute and at idle for 1 minute under no load. 	0 - 1.0V
			[Ignition switch: ON] <ul style="list-style-type: none"> ● Engine stopped [Engine is running] <ul style="list-style-type: none"> ● Engine speed: Above 3,600 rpm 	BATTERY VOLTAGE (11 - 14V)
55	W	Heated oxygen sensor 2 (Bank 2)	[Engine is running] <ul style="list-style-type: none"> ● Revving engine from idle to 3,000 rpm quickly after the following conditions are met <ul style="list-style-type: none"> - Engine: After warming up - Keeping the engine speed between 3,500 and 4,000 rpm for 1 minute and at idle for 1 minute under no load 	0 - Approximately 1.0V
78	B	Heated oxygen sensor 2 ground	[Engine is running] <ul style="list-style-type: none"> ● Warm-up condition ● Idle speed 	Approximately 0V

Diagnostic Procedure
PROCEDURE FOR MALFUNCTION A

1. CHECK GROUND CONNECTIONS

1. Turn ignition switch OFF.
2. Loosen and retighten three ground screws on the body. Refer to [EC-158, "Ground Inspection"](#) .

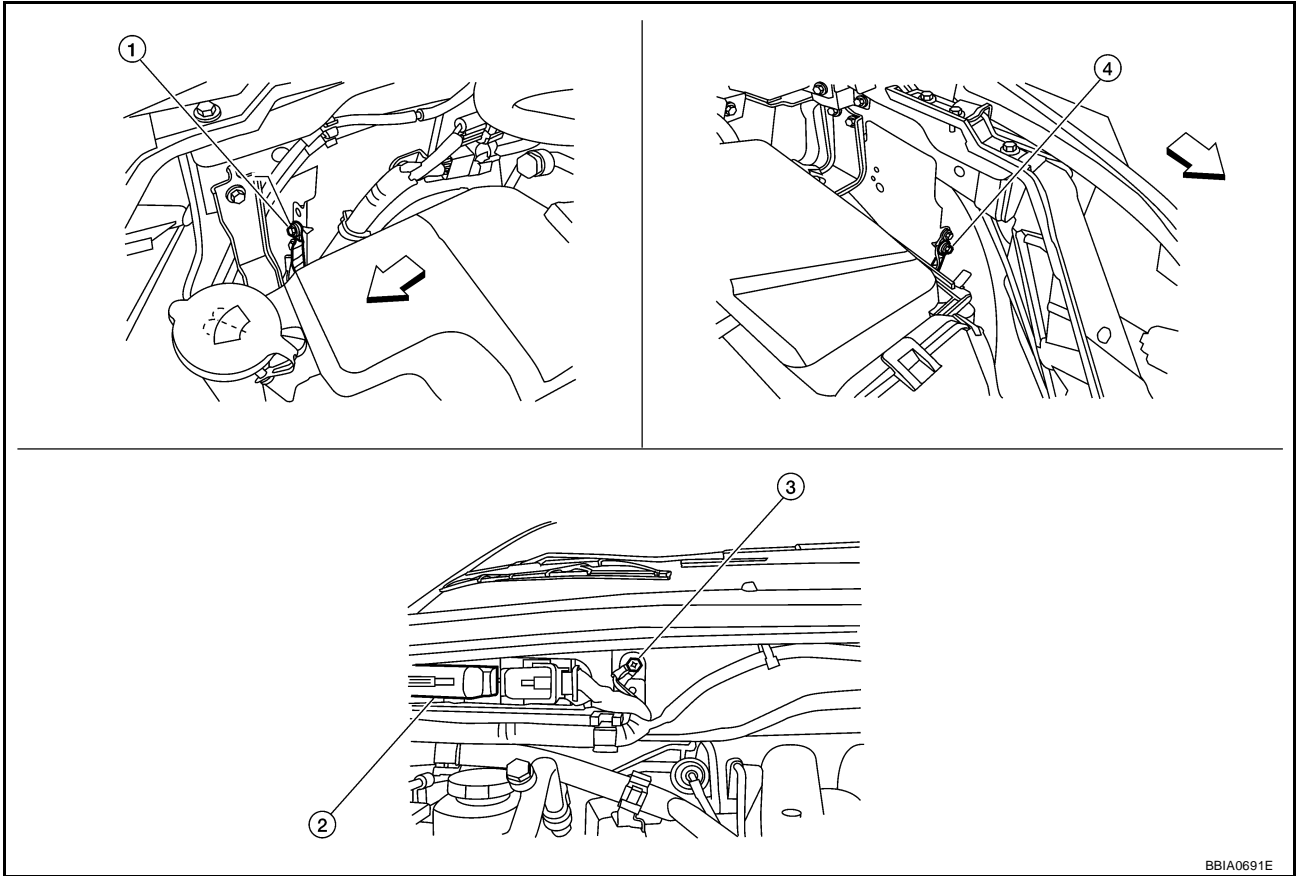

← Vehicle front

1. Body ground E24

2. ECM

3. Body ground E9

4. Body ground E15

OK or NG

OK >> GO TO 2.

NG >> Repair or replace ground connections.

BBIA0691E

DTC P0138, P0158 HO2S2

2. CHECK HO2S2 GROUND CIRCUIT FOR OPEN AND SHORT

1. Disconnect ECM harness connector.
2. Disconnect heated oxygen sensor 2 harness connector.
 - Oil pan (1)
 - Heated oxygen sensor 2 (bank 2) harness connector (2)
 - Heated oxygen sensor 2 (bank 1) harness connector (3)
3. Check harness continuity between ECM terminal 78 and HO2S2 terminal 4.
Refer to Wiring Diagram.

Continuity should exist.

4. Also check harness for short to ground and short to power.

OK or NG

OK >> GO TO 3.

NG >> Repair open circuit or short to ground or short to power in harness or connectors.

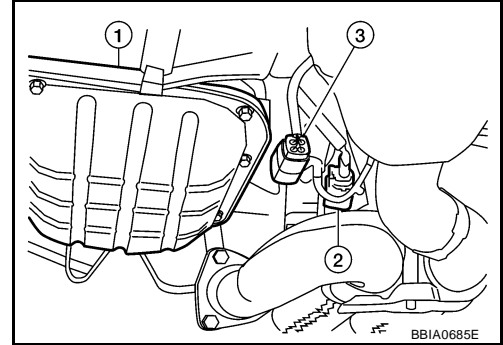

3. CHECK HO2S2 INPUT SIGNAL CIRCUIT FOR OPEN AND SHORT

1. Check harness continuity between ECM terminal and HO2S2 terminal as follows.
Refer to Wiring Diagram.

DTC	Terminals		Bank
	ECM	Sensor	
P0138	74	1	1
P0158	55	1	2

Continuity should exist.

2. Check harness continuity between the following terminals and ground.
Refer to Wiring Diagram.

DTC	Terminals		Bank
	ECM	Sensor	
P0138	74	1	1
P0158	55	1	2

Continuity should not exist.

3. Also check harness for short to power.

OK or NG

OK >> GO TO 4.

NG >> Repair open circuit or short to ground or short to power in harness or connectors.

4. CHECK HO2S2 CONNECTOR FOR WATER

Check HO2S2 connectors for water.

Water should not exist.

OK or NG

OK >> GO TO 5.

NG >> Repair or replace harness or connectors.

DTC P0138, P0158 HO2S2

5. CHECK HEATED OXYGEN SENSOR 2

Refer to [EC-307, "Component Inspection"](#) .

OK or NG

- OK >> GO TO 6.
- NG >> Replace malfunctioning heated oxygen sensor 2.

6. CHECK INTERMITTENT INCIDENT

Refer to [EC-149, "TROUBLE DIAGNOSIS FOR INTERMITTENT INCIDENT"](#) .

>> INSPECTION END

PROCEDURE FOR MALFUNCTION B

1. CHECK GROUND CONNECTIONS

1. Turn ignition switch OFF.
2. Loosen and retighten three ground screws on the body. Refer to [EC-158, "Ground Inspection"](#) .

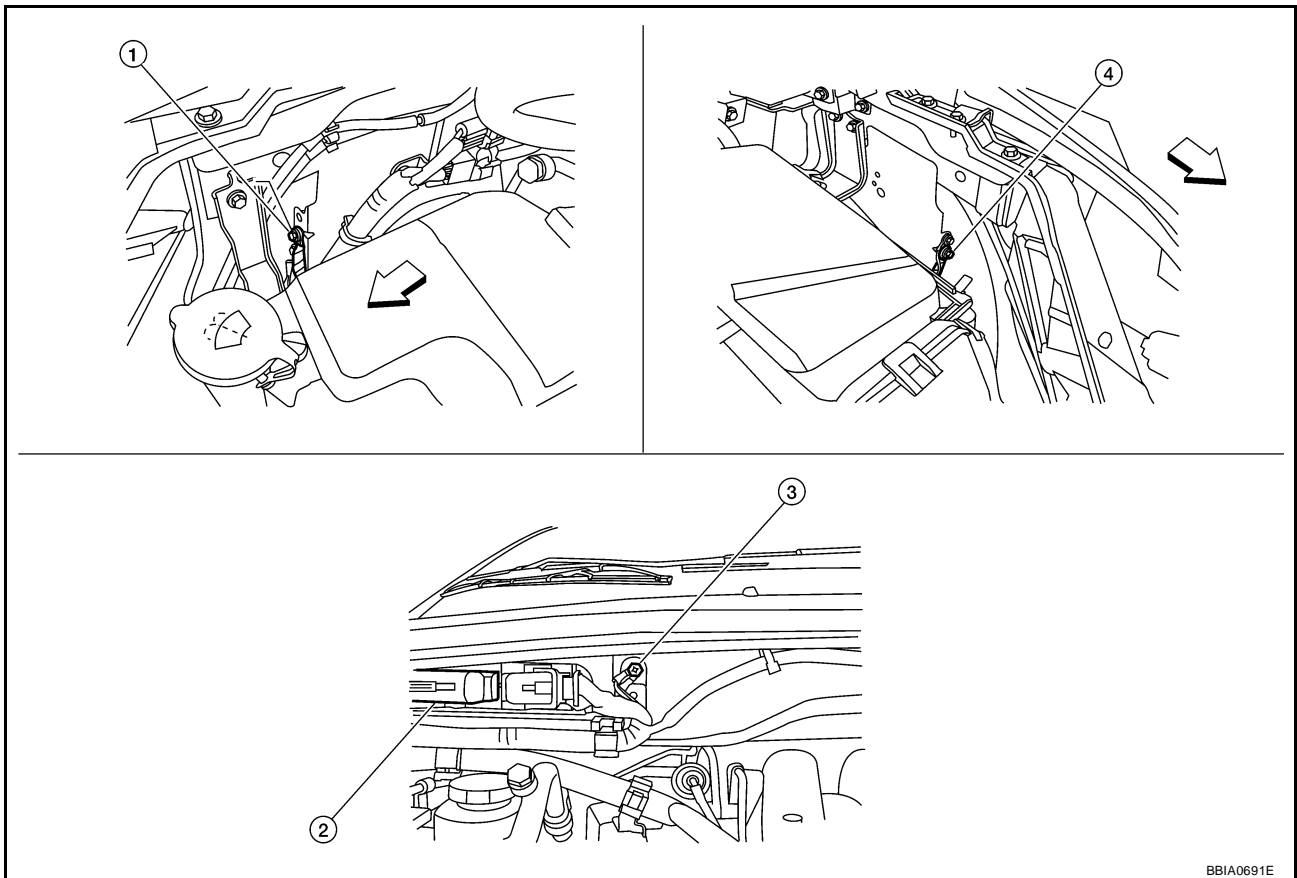

↔ Vehicle front

1. Body ground E24

2. ECM

3. Body ground E9

4. Body ground E15

OK or NG

- OK >> GO TO 2.
- NG >> Repair or replace ground connections.

2. CLEAR THE SELF-LEARNING DATA

📖 With CONSULT-II

1. Start engine and warm it up to normal operating temperature.
2. Select "SELF-LEARNING CONT" in "WORK SUPPORT" mode with CONSULT-II.
3. Clear the self-learning control coefficient by touching "CLEAR".
4. Run engine for at least 10 minutes at idle speed.
Is the 1st trip DTC P0172 or P0175 detected?
Is it difficult to start engine?

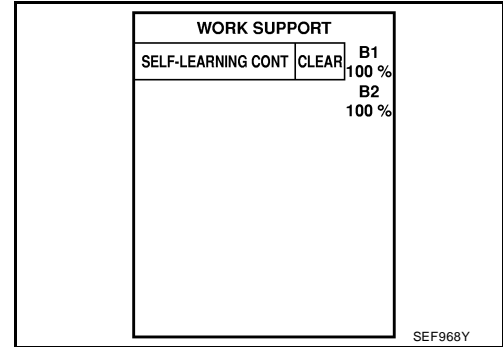

⊗ Without CONSULT-II

1. Start engine and warm it up to normal operating temperature.
2. Turn ignition switch OFF.
3. Disconnect mass air flow sensor harness connector.
4. Restart engine and let it idle for at least 5 seconds.
5. Stop engine and reconnect mass air flow sensor harness connector.
6. Make sure DTC P0102 is displayed.
7. Erase the DTC memory. Refer to [EC-63, "HOW TO ERASE EMISSION-RELATED DIAGNOSTIC INFORMATION"](#).
8. Make sure DTC P0000 is displayed.
9. Run engine for at least 10 minutes at idle speed.
Is the 1st trip DTC P0172 or P0175 detected?
Is it difficult to start engine?

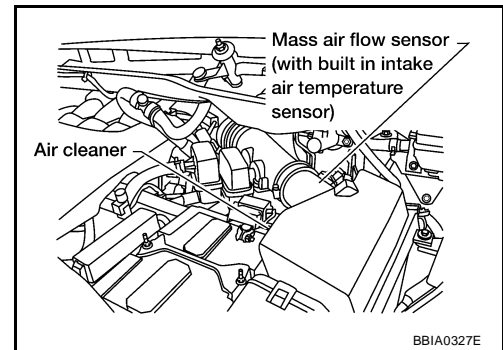

Yes or No

- Yes >> Perform trouble diagnosis for DTC P0172, P0175. Refer to [EC-334](#).
- No >> GO TO 3.

3. CHECK HO2S2 GROUND CIRCUIT FOR OPEN AND SHORT

1. Turn ignition switch OFF.
2. Disconnect ECM harness connector.
3. Disconnect heated oxygen sensor 2 harness connector.
 - Oil pan (1)
 - Heated oxygen sensor 2 (bank 2) harness connector (2)
 - Heated oxygen sensor 2 (bank 1) harness connector (3)
4. Check harness continuity between ECM terminal 78 and HO2S2 terminal 4.
 Refer to Wiring Diagram.

Continuity should exist.

5. Also check harness for short to ground and short to power.

OK or NG

- OK >> GO TO 4.
- NG >> Repair open circuit or short to ground or short to power in harness or connectors.

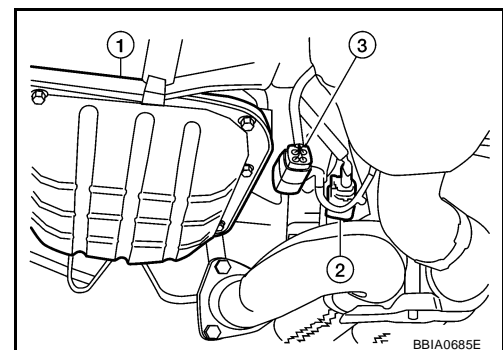

DTC P0138, P0158 HO2S2

4. CHECK HO2S2 INPUT SIGNAL CIRCUIT FOR OPEN AND SHORT

1. Check harness continuity between ECM terminal and HO2S2 terminal as follows.
Refer to Wiring Diagram.

DTC	Terminals		Bank
	ECM	Sensor	
P0138	74	1	1
P0158	55	1	2

Continuity should exist.

2. Check harness continuity between the following terminals and ground.
Refer to Wiring Diagram.

DTC	Terminals		Bank
	ECM	Sensor	
P0138	74	1	1
P0158	55	1	2

Continuity should not exist.

3. Also check harness for short to power.

OK or NG

OK >> GO TO 5.

NG >> Repair open circuit or short to ground or short to power in harness or connectors.

5. CHECK HEATED OXYGEN SENSOR 2

Refer to [EC-307, "Component Inspection"](#) .

OK or NG

OK >> GO TO 6.

NG >> Replace malfunctioning heated oxygen sensor 2.

6. CHECK INTERMITTENT INCIDENT

Refer to [EC-149, "TROUBLE DIAGNOSIS FOR INTERMITTENT INCIDENT"](#) .

>> INSPECTION END

Component Inspection HEATED OXYGEN SENSOR 2

UBS00P63

④ **With CONSULT-II**

1. Start engine and warm it up to the normal operating temperature.
2. Turn ignition switch OFF and wait at least 10 seconds.
3. Start engine and keep the engine speed between 3,500 and 4,000 rpm for at least 1 minute under no load.
4. Let engine idle for 1 minute.

DTC P0138, P0158 HO2S2

5. Select "FUEL INJECTION" in "ACTIVE TEST" mode, and select "HO2S2 (B1)/(B2)" as the monitor item with CONSULT-II.

ACTIVE TEST	
FUEL INJECTION	25 %
MONITOR	
ENG SPEED	XXX rpm
HO2S2 (B1)	XXX V
HO2S2 (B2)	XXX V

PBIB1672E

6. Check "HO2S2 (B1)/(B2)" at idle speed when adjusting "FUEL INJECTION" to $\pm 25\%$.

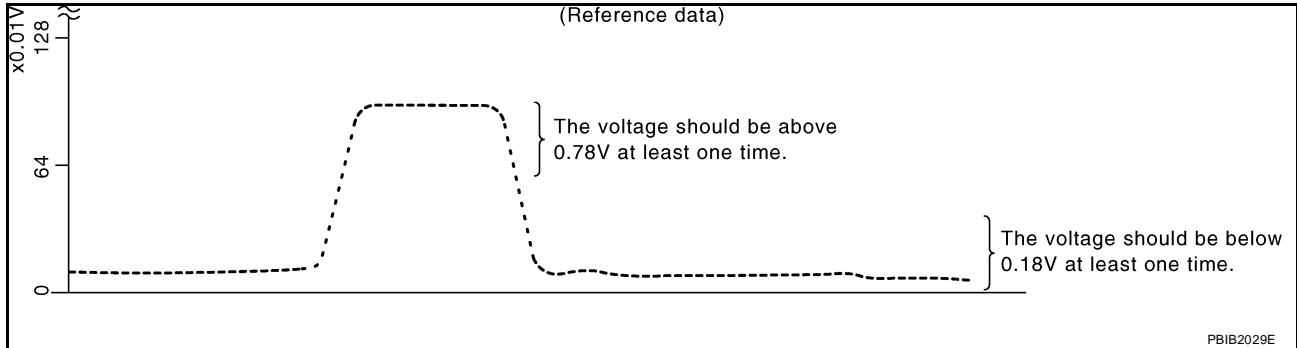

"HO2S2 (B1)/(B2)" should be above 0.78V at least once when the "FUEL INJECTION" is +25%.
 "HO2S2 (B1)/(B2)" should be below 0.18V at least once when the "FUEL INJECTION" is -25%.

7. If NG, replace heated oxygen sensor 2.

CAUTION:

- Discard any heated oxygen sensor which has been dropped from a height of more than 0.5 m (19.7 in) onto a hard surface such as a concrete floor; use a new one.
- Before installing new oxygen sensor, clean exhaust system threads using Oxygen Sensor Thread Cleaner tool J-43897-18 or J-43897-12 and approved anti-seize lubricant.

⊗ **Without CONSULT-II**

1. Start engine and warm it up to the normal operating temperature.
2. Turn ignition switch OFF and wait at least 10 seconds.
3. Start engine and keep the engine speed between 3,500 and 4,000 rpm for at least 1 minute under no load.
4. Let engine idle for 1 minute.
5. Set voltmeter probes between ECM terminal 74 [HO2S2 (B1) signal] or 55 [HO2S2 (B2) signal] and ground.
6. Check the voltage when revving up to 4,000 rpm under no load at least 10 times.
 (Depress and release accelerator pedal as soon as possible.)
The voltage should be above 0.78V at least once during this procedure.
If the voltage is above 0.78V at step 6, step 7 is not necessary.
7. Keep vehicle at idling for 10 minutes, then check voltage.
 Or check the voltage when coasting from 80 km/h (50 MPH) in D position with "OD" OFF.
The voltage should be below 0.18V at least once during this procedure.
8. If NG, replace heated oxygen sensor 2.

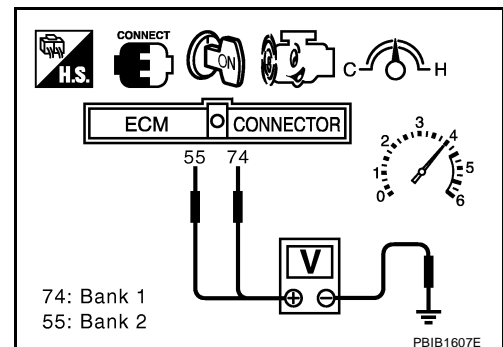

CAUTION:

- Discard any heated oxygen sensor which has been dropped from a height of more than 0.5 m (19.7 in) onto a hard surface such as a concrete floor; use a new one.

DTC P0138, P0158 HO2S2

- Before installing new oxygen sensor, clean exhaust system threads using Oxygen Sensor Thread Cleaner tool J-43897-18 or J-43897-12 and approved anti-seize lubricant.

Removal and Installation HEATED OXYGEN SENSOR 2

UBS00P64

Refer to [EM-26, "EXHAUST MANIFOLD AND THREE WAY CATALYST"](#) .

A

EC

C

D

E

F

G

H

I

J

K

L

M

DTC P0139, P0159 HO2S2

DTC P0139, P0159 HO2S2

PF0:226A0

Component Description

UBS00P65

The heated oxygen sensor 2, after three way catalyst (manifold), monitors the oxygen level in the exhaust gas on each bank.

Even if switching characteristics of the A/F sensor 1 are shifted, the air-fuel ratio is controlled to stoichiometric, by the signal from the heated oxygen sensor 2.

This sensor is made of ceramic zirconia. The zirconia generates voltage from approximately 1V in richer conditions to 0V in leaner conditions.

Under normal conditions the heated oxygen sensor 2 is not used for engine control operation.

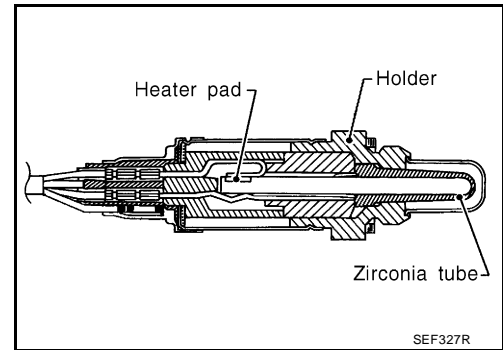

CONSULT-II Reference Value in Data Monitor Mode

UBS00P66

Specification data are reference values.

MONITOR ITEM	CONDITION	SPECIFICATION
HO2S2 (B1) HO2S2 (B2)	<ul style="list-style-type: none"> ● Revving engine from idle to 3,000 rpm quickly after the following conditions are met – Engine: After warming up 	0 - 0.3V ↔ Approx. 0.6 - 1.0V
HO2S2 MNTR (B1) HO2S2 MNTR (B2)	<ul style="list-style-type: none"> – Keeping the engine speed between 3,500 and 4,000 rpm for 1 minute and at idle for 1 minute under no load 	LEAN ↔ RICH

On Board Diagnosis Logic

UBS00P67

The heated oxygen sensor 2 has a much longer switching time between rich and lean than the A/F sensor 1. The oxygen storage capacity of the three way catalyst (manifold) causes the longer switching time. To judge the malfunctions of heated oxygen sensor 2, ECM monitors whether the switching response of the sensor's voltage is faster than specified during the various driving condition such as fuel-cut.

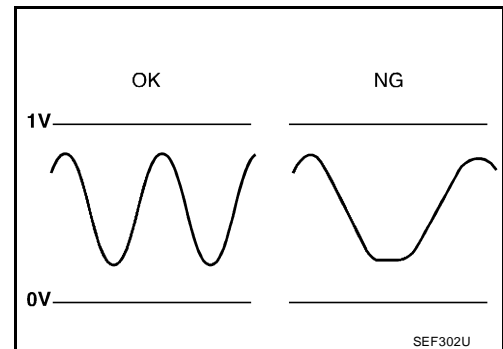

DTC No.	Trouble diagnosis name	DTC detecting condition	Possible cause
P0139 0139 (Bank 1)	Heated oxygen sensor 2 circuit slow response	It takes more time for the sensor to respond between rich and lean than the specified time.	<ul style="list-style-type: none"> ● Harness or connectors (The sensor circuit is open or shorted) ● Heated oxygen sensor 2
P0159 0159 (Bank 2)			<ul style="list-style-type: none"> ● Fuel pressure ● Fuel injector ● Intake air leaks

DTC P0139, P0159 HO2S2

UBS00P68

DTC Confirmation Procedure

NOTE:

If DTC Confirmation Procedure has been previously conducted, always turn ignition switch OFF and wait at least 10 seconds before conducting the next test.

④ WITH CONSULT-II

TESTING CONDITION:

For better results, perform "DTC WORK SUPPORT" at a temperature of 0 to 30 °C (32 to 86 °F).

1. Turn ignition switch ON and select "DATA MONITOR" mode with CONSULT-II.
2. Start engine and warm it up to the normal operating temperature.
3. Turn ignition switch OFF and wait at least 10 seconds.
4. Start engine and keep the engine speed between 3,500 and 4,000 rpm for at least 1 minute under no load.
5. Let engine idle for 1 minute.
6. Make sure that "COOLAN TEMP/S" indicates more than 70°C (158°F).
If not, warm up engine and go to next step when "COOLAN TEMP/S" indication reaches to 70°C (158°F).
7. Select "HO2S2 (B1) P0139" or "HO2S2 (B2) P0159" of "HO2S2" in "DTC WORK SUPPORT" mode with CONSULT-II.
8. Start engine and following the instruction of CONSULT-II.

DATA MONITOR	
MONITOR	NO DTC
ENG SPEED	XXX rpm
COOLAN TEMP/S	XXX °C

SEF174Y

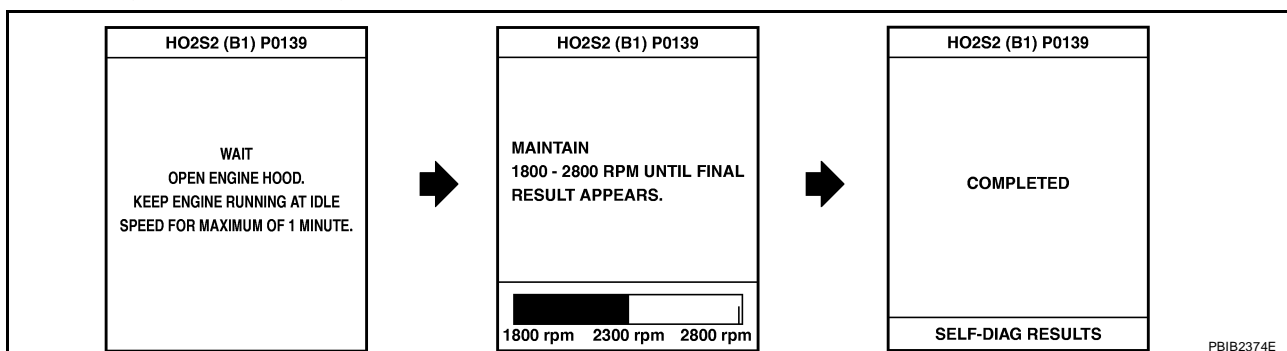

NOTE:

It will take at most 10 minutes until "COMPLETED" is displayed.

9. Make sure that "OK" is displayed after touching "SELF-DIAG RESULTS".
If "NG" is displayed, refer to [EC-317, "Diagnostic Procedure"](#).
If "CAN NOT BE DIAGNOSED" is displayed, perform the following.
 - a. Turn ignition switch OFF and leave the vehicle in a cool place (soak the vehicle).
 - b. Return to step 1.

Overall Function Check

UBS00P69

Use this procedure to check the overall function of the heated oxygen sensor 2 circuit. During this check, a 1st trip DTC might not be confirmed.

④ WITH GST

1. Start engine and warm it up to the normal operating temperature.
2. Turn ignition switch OFF and wait at least 10 seconds.
3. Start engine and keep the engine speed between 3,500 and 4,000 rpm for at least 1 minute under no load.
4. Let engine idle for 1 minute.
5. Set voltmeter probes between ECM terminal 74 [HO2S2 (B1) signal] or 55 [HO2S2 (B2) signal] and ground.

DTC P0139, P0159 HO2S2

6. Check the voltage when revving up to 4,000 rpm under no load at least 10 times.
(Depress and release accelerator pedal as soon as possible.)
A change of voltage should be more than 0.06V for 1 second during this procedure.
If the voltage can be confirmed in step 6, step 7 is not necessary.
7. Keep vehicle at idling for 10 minutes, then check the voltage.
Or check the voltage when coasting from 80 km/h (50 MPH) in D position with "OD" OFF.
A change of voltage should be more than 0.06V for 1 second during this procedure.
8. If NG, go to [EC-317, "Diagnostic Procedure"](#).

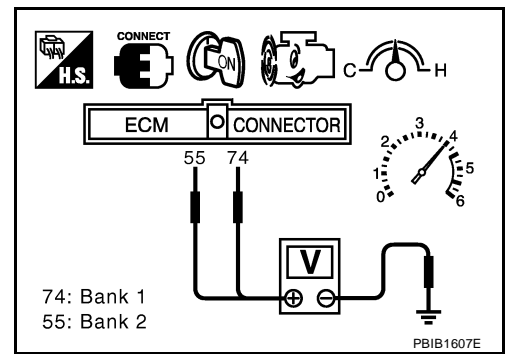

DTC P0139, P0159 HO2S2

UBS00P6A

Wiring Diagram BANK 1

EC-O2S2B1-01

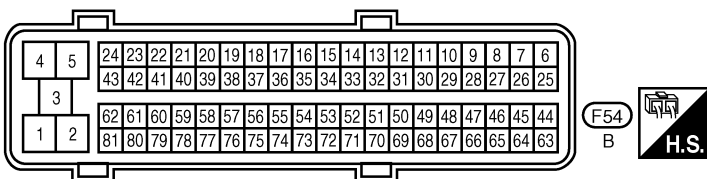
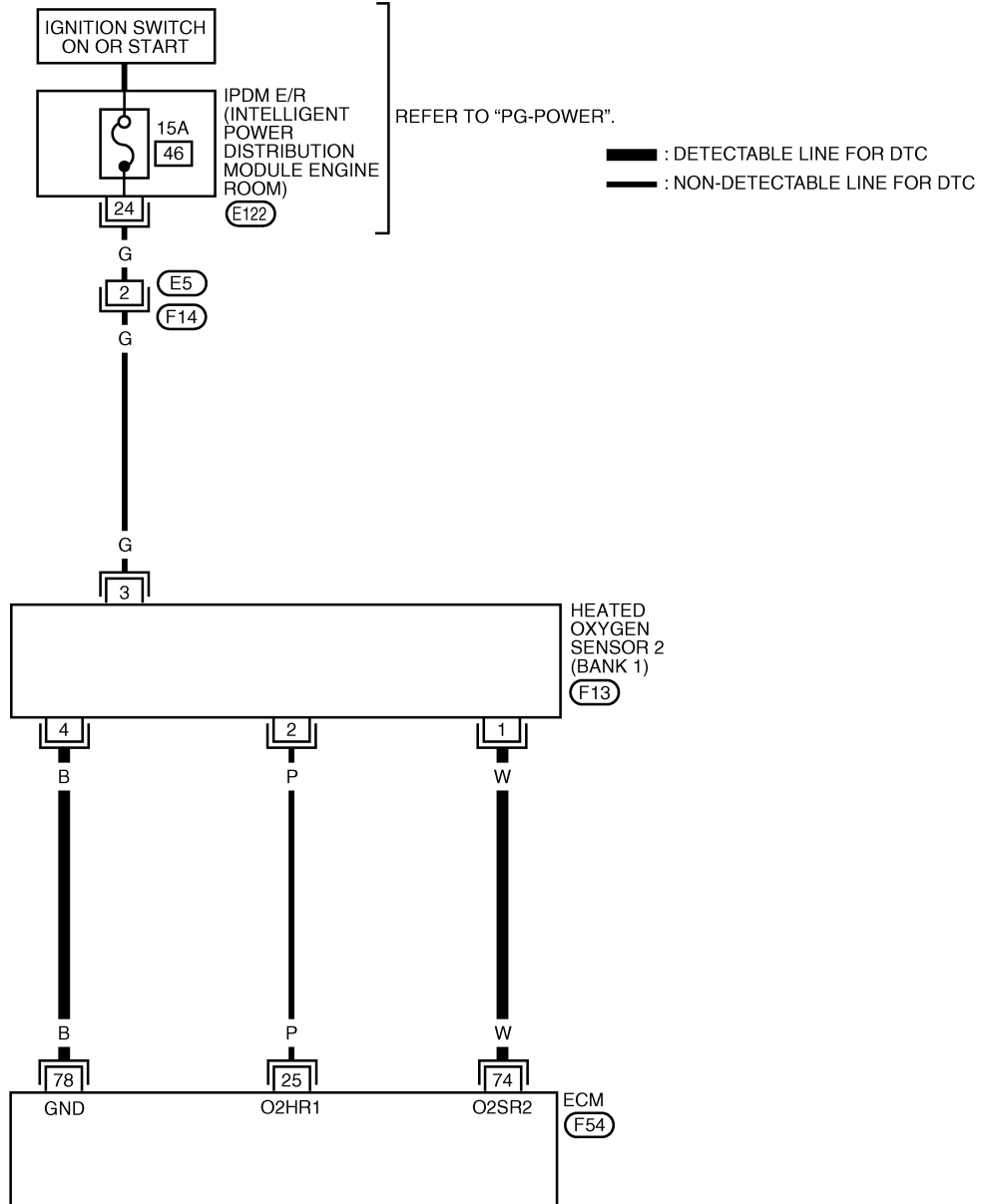

BBWA2509E

DTC P0139, P0159 HO2S2

Specification data are reference values and are measured between each terminal and ground.

CAUTION:

Do not use ECM ground terminals when measuring input/output voltage. Doing so may result in damage to the ECM's transistor. Use a ground other than ECM terminals, such as the ground.

TER-MINAL NO.	WIRE COLOR	ITEM	CONDITION	DATA (DC Voltage)
25	P	Heated oxygen sensor 2 heater (Bank 1)	[Engine is running] <ul style="list-style-type: none"> ● Engine speed: Below 3,600 rpm after the following conditions are met <ul style="list-style-type: none"> - Engine: After warming up - Keeping the engine speed between 3,500 and 4,000 rpm for 1 minute and at idle for 1 minute under no load. 	0 - 1.0V
			[Ignition switch: ON] <ul style="list-style-type: none"> ● Engine stopped [Engine is running] <ul style="list-style-type: none"> ● Engine speed: Above 3,600 rpm 	BATTERY VOLTAGE (11 - 14V)
74	W	Heated oxygen sensor 2 (Bank 1)	[Engine is running] <ul style="list-style-type: none"> ● Revving engine from idle to 3,000 rpm quickly after the following conditions are met <ul style="list-style-type: none"> - Engine: After warming up - Keeping the engine speed between 3,500 and 4,000 rpm for 1 minute and at idle for 1 minute under no load 	0 - Approximately 1.0V
78	B	Heated oxygen sensor 2 ground	[Engine is running] <ul style="list-style-type: none"> ● Warm-up condition ● Idle speed 	Approximately 0V

DTC P0139, P0159 HO2S2

BANK 2

EC-O2S2B2-01

— : DETECTABLE LINE FOR DTC
 - - - : NON-DETECTABLE LINE FOR DTC

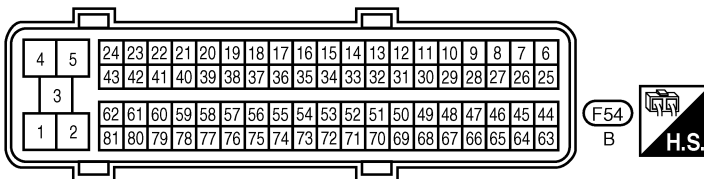
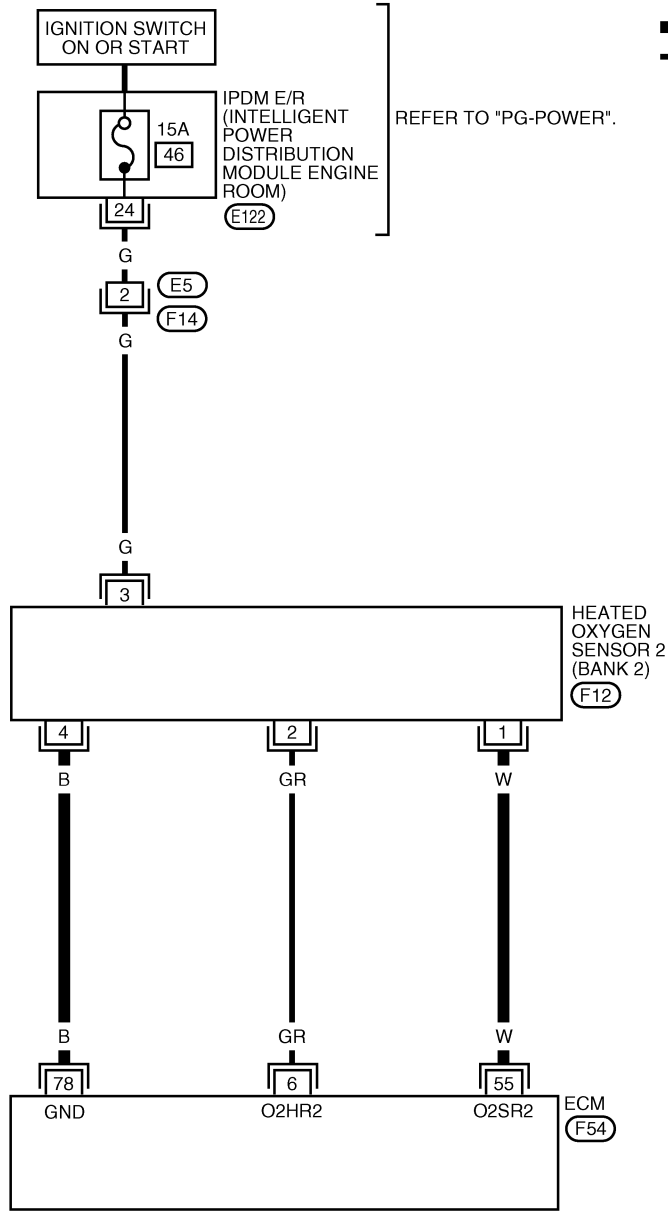

BBWA2510E

DTC P0139, P0159 HO2S2

Specification data are reference values and are measured between each terminal and ground.

CAUTION:

Do not use ECM ground terminals when measuring input/output voltage. Doing so may result in damage to the ECM's transistor. Use a ground other than ECM terminals, such as the ground.

TER-MINAL NO.	WIRE COLOR	ITEM	CONDITION	DATA (DC Voltage)
6	GR	Heated oxygen sensor 2 heater (Bank 2)	[Engine is running] <ul style="list-style-type: none"> ● Engine speed: Below 3,600 rpm after the following conditions are met <ul style="list-style-type: none"> - Engine: After warming up - Keeping the engine speed between 3,500 and 4,000 rpm for 1 minute and at idle for 1 minute under no load. 	0 - 1.0V
			[Ignition switch: ON] <ul style="list-style-type: none"> ● Engine stopped [Engine is running] <ul style="list-style-type: none"> ● Engine speed: Above 3,600 rpm 	BATTERY VOLTAGE (11 - 14V)
55	W	Heated oxygen sensor 2 (Bank 2)	[Engine is running] <ul style="list-style-type: none"> ● Revving engine from idle to 3,000 rpm quickly after the following conditions are met <ul style="list-style-type: none"> - Engine: After warming up - Keeping the engine speed between 3,500 and 4,000 rpm for 1 minute and at idle for 1 minute under no load 	0 - Approximately 1.0V
78	B	Heated oxygen sensor 2 ground	[Engine is running] <ul style="list-style-type: none"> ● Warm-up condition ● Idle speed 	Approximately 0V

Diagnostic Procedure

1. CHECK GROUND CONNECTIONS

1. Turn ignition switch OFF.
2. Loosen and retighten three ground screws on the body. Refer to [EC-158, "Ground Inspection"](#).

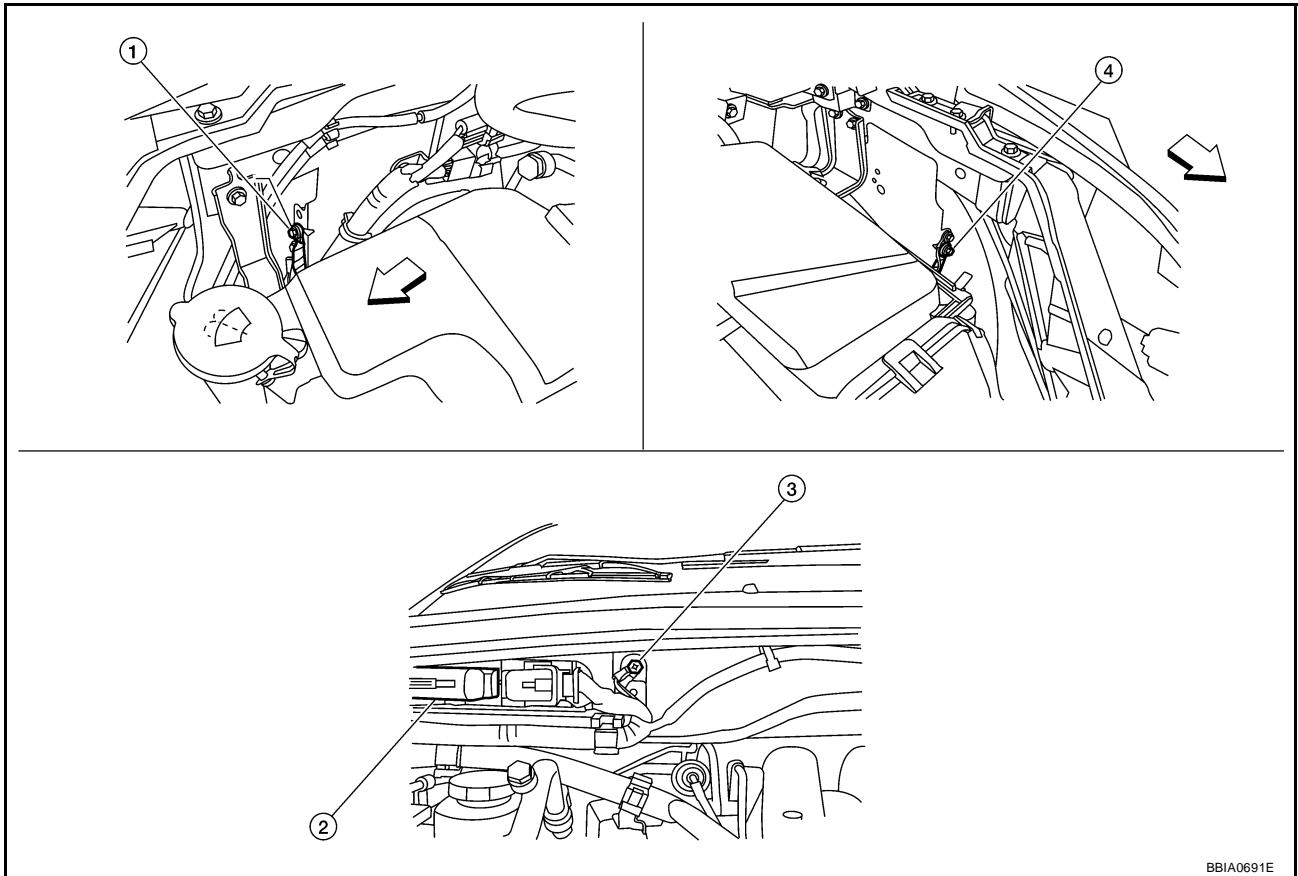

↔ Vehicle front

1. Body ground E24
4. Body ground E15

2. ECM

3. Body ground E9

OK or NG

- OK >> GO TO 2.
 NG >> Repair or replace ground connections.

BBIA0691E

A
 EC
 C
 D
 E
 F
 G
 H
 I
 J
 K
 L
 M

2. CLEAR THE SELF-LEARNING DATA

With CONSULT-II

1. Start engine and warm it up to normal operating temperature.
2. Select "SELF-LEARNING CONT" in "WORK SUPPORT" mode with CONSULT-II.
3. Clear the self-learning control coefficient by touching "CLEAR".
4. Run engine for at least 10 minutes at idle speed.
Is the 1st trip DTC P0171, P0172, P0174 or P0175 detected?
Is it difficult to start engine?

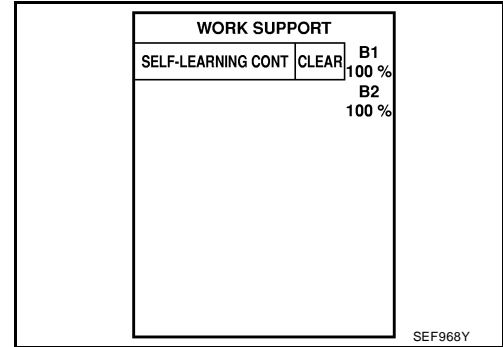

Without CONSULT-II

1. Start engine and warm it up to normal operating temperature.
2. Turn ignition switch OFF.
3. Disconnect mass air flow sensor harness connector.
4. Restart engine and let it idle for at least 5 seconds.
5. Stop engine and reconnect mass air flow sensor harness connector.
6. Make sure DTC P0102 is displayed.
7. Erase the DTC memory. Refer to [EC-63, "HOW TO ERASE EMISSION-RELATED DIAGNOSTIC INFORMATION"](#) .
8. Make sure DTC P0000 is displayed.
9. Run engine for at least 10 minutes at idle speed.
Is the 1st trip DTC P0171, P0172, P0174 or P0175 detected?
Is it difficult to start engine?

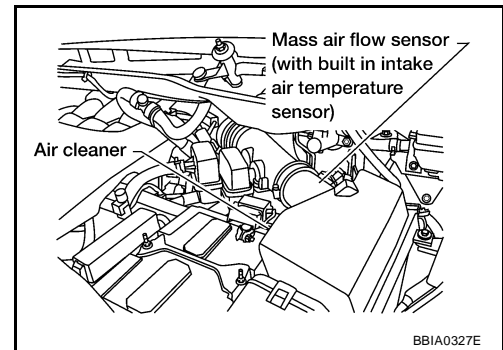

Yes or No

- Yes >> Perform trouble diagnosis for DTC P0171, P0174 or P0172, P0175. Refer to [EC-322, "DTC P0171, P0174 FUEL INJECTION SYSTEM FUNCTION"](#) or [EC-334, "DTC P0172, P0175 FUEL INJECTION SYSTEM FUNCTION"](#) .
- No >> GO TO 3.

3. CHECK HO2S2 GROUND CIRCUIT FOR OPEN AND SHORT

1. Turn ignition switch OFF.
2. Disconnect ECM harness connector.
3. Disconnect heated oxygen sensor 2 harness connector.
 - Oil pan (1)
 - Heated oxygen sensor 2 (bank 2) harness connector (2)
 - Heated oxygen sensor 2 (bank 1) harness connector (3)
4. Check harness continuity between ECM terminal 78 and HO2S2 terminal 4.
 Refer to Wiring Diagram.

Continuity should exist.

5. Also check harness for short to ground and short to power.

OK or NG

- OK >> GO TO 4.
- NG >> Repair open circuit or short to ground or short to power in harness or connectors.

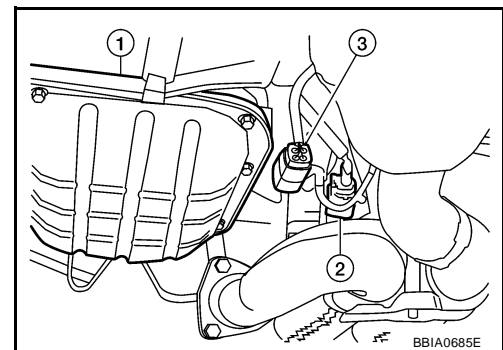

DTC P0139, P0159 HO2S2

4. CHECK HO2S2 INPUT SIGNAL CIRCUIT FOR OPEN AND SHORT

1. Check harness continuity between ECM terminal and HO2S2 terminal as follows.
Refer to Wiring Diagram.

DTC	Terminals		Bank
	ECM	Sensor	
P0139	74	1	1
P0159	55	1	2

Continuity should exist.

2. Check harness continuity between the following terminals and ground.
Refer to Wiring Diagram.

DTC	Terminals		Bank
	ECM	Sensor	
P0139	74	1	1
P0159	55	1	2

Continuity should not exist.

3. Also check harness for short to power.

OK or NG

OK >> GO TO 5.

NG >> Repair open circuit or short to ground or short to power in harness or connectors.

5. CHECK HEATED OXYGEN SENSOR 2

Refer to [EC-319, "Component Inspection"](#) .

OK or NG

OK >> GO TO 6.

NG >> Replace malfunctioning heated oxygen sensor 2.

6. CHECK INTERMITTENT INCIDENT

Refer to [EC-149, "TROUBLE DIAGNOSIS FOR INTERMITTENT INCIDENT"](#) .

>> INSPECTION END

Component Inspection HEATED OXYGEN SENSOR 2

UBS00P6C

④ With CONSULT-II

- Turn ignition switch ON and select "DATA MONITOR" mode with CONSULT-II.
- Start engine and warm it up to the normal operating temperature.
- Turn ignition switch OFF and wait at least 10 seconds.
- Start engine and keep the engine speed between 3,500 and 4,000 rpm for at least 1 minute under no load.
- Let engine idle for 1 minute.

DATA MONITOR	
MONITOR	NO DTC
ENG SPEED	XXX rpm
COOLAN TEMP/S	XXX °C

SEF174Y

DTC P0139, P0159 HO2S2

6. Select "FUEL INJECTION" in "ACTIVE TEST" mode, and select "HO2S2 (B1)/(B2)" as the monitor item with CONSULT-II.

ACTIVE TEST	
FUEL INJECTION	25 %
MONITOR	
ENG SPEED	XXX rpm
HO2S2 (B1)	XXX V
HO2S2 (B2)	XXX V

PBIB1672E

7. Check "HO2S2 (B1)/(B2)" at idle speed when adjusting "FUEL INJECTION" to $\pm 25\%$.

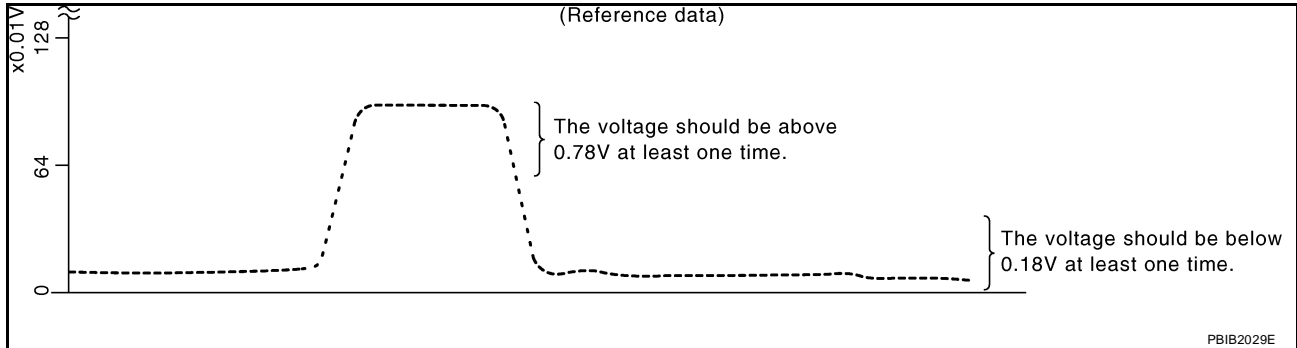

"HO2S2 (B1)/(B2)" should be above 0.78V at least once when the "FUEL INJECTION" is +25%.
 "HO2S2 (B1)/(B2)" should be below 0.18V at least once when the "FUEL INJECTION" is -25%.

CAUTION:

- Discard any heated oxygen sensor which has been dropped from a height of more than 0.5 m (19.7 in) onto a hard surface such as a concrete floor; use a new one.
- Before installing new oxygen sensor, clean exhaust system threads using Oxygen Sensor Thread Cleaner tool J-43897-18 or J-43897-12 and approved anti-seize lubricant.

⊗ Without CONSULT-II

1. Start engine and warm it up to the normal operating temperature.
2. Turn ignition switch OFF and wait at least 10 seconds.
3. Start engine and keep the engine speed between 3,500 and 4,000 rpm for at least 1 minute under no load.
4. Let engine idle for 1 minute.
5. Set voltmeter probes between ECM terminal 74 [HO2S2 (B1) signal] or 55 [HO2S2 (B2) signal] and ground.
6. Check the voltage when revving up to 4,000 rpm under no load at least 10 times.
 (Depress and release accelerator pedal as soon as possible.)
The voltage should be above 0.78V at least once during this procedure.
If the voltage is above 0.78V at step 6, step 7 is not necessary.
7. Keep vehicle at idling for 10 minutes, then check voltage.
 Or check the voltage when coasting from 80 km/h (50 MPH) in D position with "OD" OFF.
The voltage should be below 0.18V at least once during this procedure.
8. If NG, replace heated oxygen sensor 2.

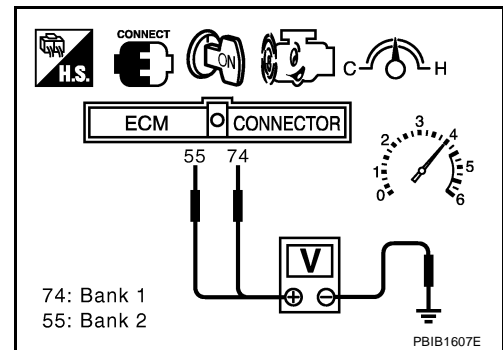

CAUTION:

- Discard any heated oxygen sensor which has been dropped from a height of more than 0.5 m (19.7 in) onto a hard surface such as a concrete floor; use a new one.
- Before installing new oxygen sensor, clean exhaust system threads using Oxygen Sensor Thread Cleaner tool J-43897-18 or J-43897-12 and approved anti-seize lubricant.

Removal and Installation
HEATED OXYGEN SENSOR 2

UBS00P6D

Refer to [EM-26, "EXHAUST MANIFOLD AND THREE WAY CATALYST"](#) .

A

EC

C

D

E

F

G

H

I

J

K

L

M

DTC P0171, P0174 FUEL INJECTION SYSTEM FUNCTION

DTC P0171, P0174 FUEL INJECTION SYSTEM FUNCTION

PF1:16600

On Board Diagnosis Logic

UBS00P6E

With the Air/Fuel Mixture Ratio Self-Learning Control, the actual mixture ratio can be brought closely to the theoretical mixture ratio based on the mixture ratio feedback signal from the A/F sensors 1. The ECM calculates the necessary compensation to correct the offset between the actual and the theoretical ratios. In case the amount of the compensation value is extremely large (The actual mixture ratio is too lean.), the ECM judges the condition as the fuel injection system malfunction and lights up the MIL (2 trip detection logic).

Sensor	Input signal to ECM	ECM function	Actuator
A/F sensors 1	Density of oxygen in exhaust gas (Mixture ratio feedback signal)	Fuel injection control	Fuel injector

DTC No.	Trouble diagnosis name	DTC detecting condition	Possible cause
P0171 0171 (Bank 1)	Fuel injection system too lean	<ul style="list-style-type: none"> Fuel injection system does not operate properly. The amount of mixture ratio compensation is too large. (The mixture ratio is too lean.) 	<ul style="list-style-type: none"> Intake air leaks A/F sensor 1 Fuel injector Exhaust gas leaks Incorrect fuel pressure Lack of fuel Mass air flow sensor Incorrect PCV hose connection
P0174 0174 (Bank 2)			

DTC Confirmation Procedure

UBS00P6F

NOTE:

If DTC Confirmation Procedure has been previously conducted, always turn ignition switch OFF and wait at least 10 seconds before conducting the next test.

④ WITH CONSULT-II

- Start engine and warm it up to normal operating temperature.
- Turn ignition switch OFF and wait at least 10 seconds.
- Turn ignition switch ON and select "SELF-LEARNING CONT" in "WORK SUPPORT" mode with CONSULT-II.
- Clear the self-learning control coefficient by touching "CLEAR".
- Select "DATA MONITOR" mode with CONSULT-II.
- Start engine again and let it idle for at least 10 minutes. The 1st trip DTC P0171 or P0174 should be detected at this stage, if a malfunction exists. If so, go to [EC-328, "Diagnostic Procedure"](#).

NOTE:

If 1st trip DTC is not detected during above procedure, performing the following procedure is advised.

- Turn ignition switch OFF and wait at least 10 seconds.
- Start engine and drive the vehicle under the similar conditions to (1st trip) Freeze Frame Data for 10 minutes. Refer to the table below. **Hold the accelerator pedal as steady as possible.**

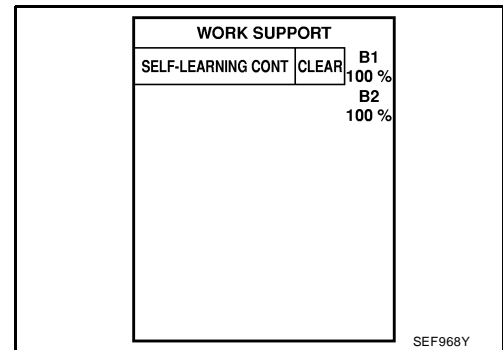

The similar conditions to (1st trip) Freeze Frame Data means the vehicle operation that the following conditions should be satisfied at the same time.

Engine speed	Engine speed in the freeze frame data \pm 400 rpm
Vehicle speed	Vehicle speed in the freeze frame data \pm 10 km/h (6 MPH)
Engine coolant temperature (T) condition	When the freeze frame data shows lower than 70 °C (158 °F), T should be lower than 70 °C (158 °F).
	When the freeze frame data shows higher than or equal to 70 °C (158 °F), T should be higher than or equal to 70 °C (158 °F).

DTC P0171, P0174 FUEL INJECTION SYSTEM FUNCTION

7. If it is difficult to start engine at step 6, the fuel injection system has a malfunction, too.
8. Crank engine while depressing accelerator pedal. If engine starts, go to [EC-328, "Diagnostic Procedure"](#). If engine does not start, check exhaust and intake air leak visually.

WITH GST

1. Start engine and warm it up to normal operating temperature.
2. Turn ignition switch OFF and wait at least 10 seconds.
3. Disconnect mass air flow sensor harness connector.
4. Restart engine and let it idle for at least 5 seconds.
5. Stop engine and reconnect mass air flow sensor harness connector.
6. Select Service \$03 with GST. Make sure DTC P0102 is detected.
7. Select Service \$04 with GST and erase the DTC P0102.
8. Start engine again and let it idle for at least 10 minutes.
9. Select Service \$07 with GST. The 1st trip DTC P0171 or P0174 should be detected at this stage, if a malfunction exists. If so, go to [EC-328, "Diagnostic Procedure"](#).

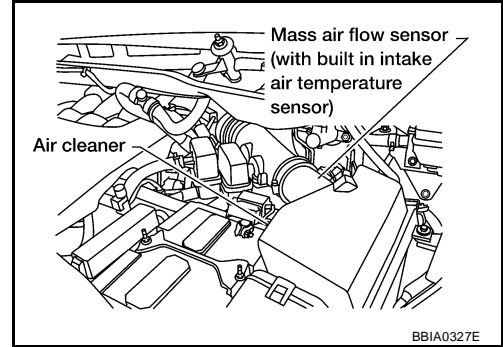

NOTE:

If 1st trip DTC is not detected during above procedure, performing the following procedure is advised.

- a. Turn ignition switch OFF and wait at least 10 seconds.
- b. Start engine and drive the vehicle under the similar conditions to (1st trip) Freeze Frame Data for 10 minutes. Refer to the table below.

Hold the accelerator pedal as steady as possible.

The similar conditions to (1st trip) Freeze Frame Data means the vehicle operation that the following conditions should be satisfied at the same time.

Engine speed	Engine speed in the freeze frame data \pm 400 rpm
Vehicle speed	Vehicle speed in the freeze frame data \pm 10 km/h (6 MPH)
Engine coolant temperature (T) condition	When the freeze frame data shows lower than 70 °C (158 °F), T should be lower than 70 °C (158 °F).
	When the freeze frame data shows higher than or equal to 70 °C (158 °F), T should be higher than or equal to 70 °C (158 °F).

10. If it is difficult to start engine at step 8, the fuel injection system has a malfunction.
11. Crank engine while depressing accelerator pedal. If engine starts, go to [EC-328, "Diagnostic Procedure"](#). If engine does not start, check exhaust and intake air leak visually.

DTC P0171, P0174 FUEL INJECTION SYSTEM FUNCTION

UBS00P6G

Wiring Diagram BANK 1

EC-FUELB1-01

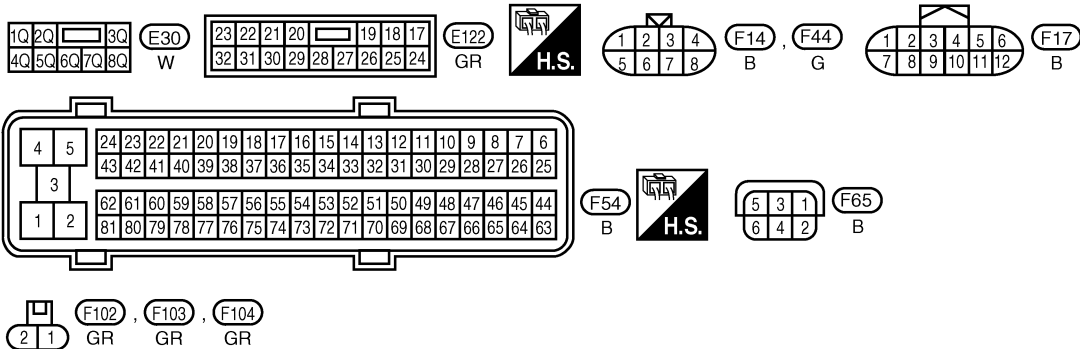
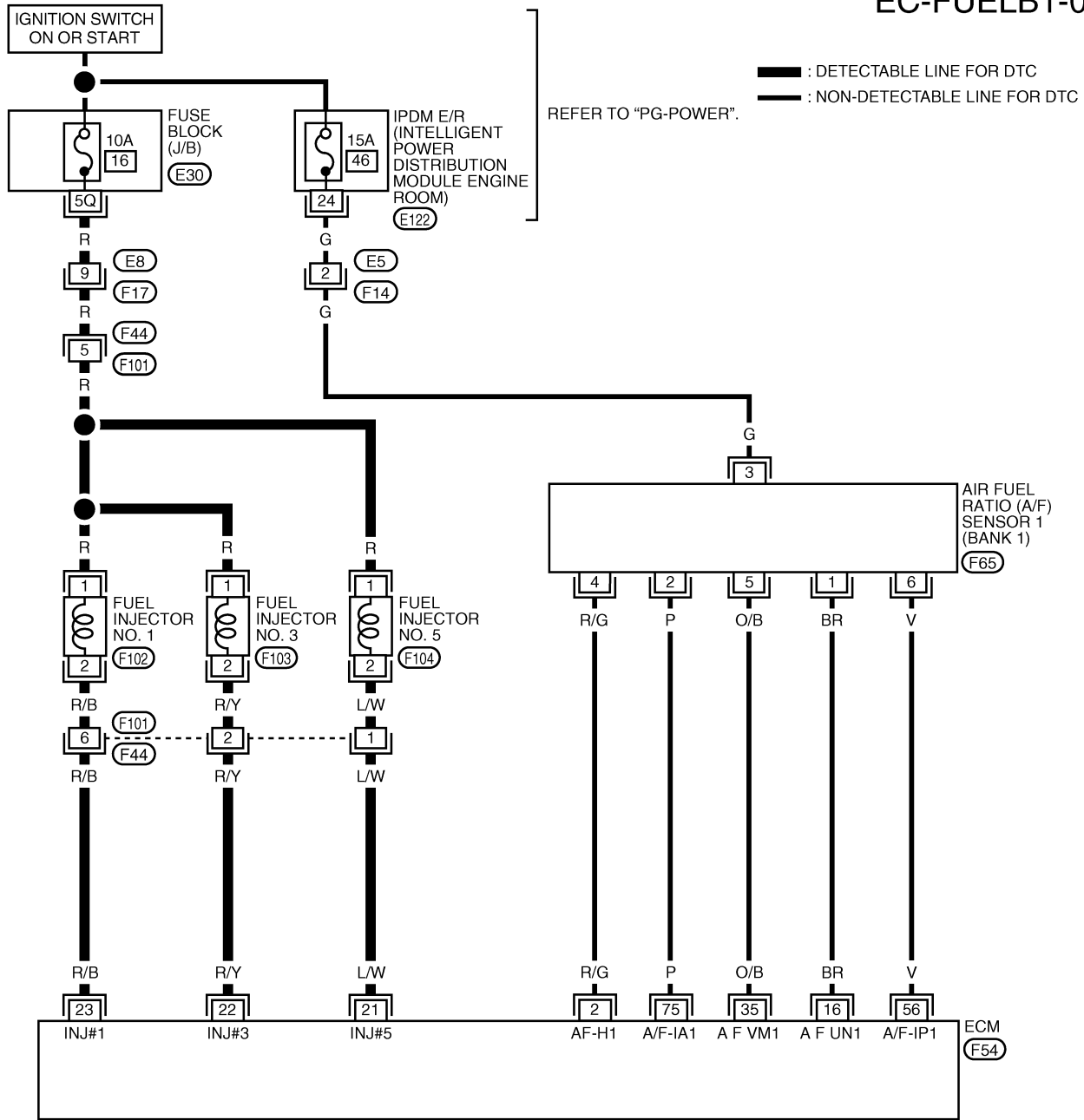

BBWA2514E

DTC P0171, P0174 FUEL INJECTION SYSTEM FUNCTION

Specification data are reference values and are measured between each terminal and ground.
Pulse signal is measured by CONSULT-II.

CAUTION:

Do not use ECM ground terminals when measuring input/output voltage. Doing so may result in damage to the ECM's transistor. Use a ground other than ECM terminals, such as the ground.

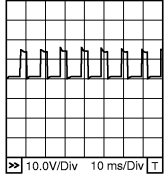
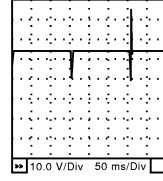
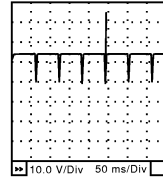
TERMI- NAL NO.	WIRE COLOR	ITEM	CONDITION	DATA (DC Voltage)
2	R/G	A/F sensor 1 heater (Bank 1)	<p>[Engine is running]</p> <ul style="list-style-type: none"> ● Warm-up condition ● Idle speed 	<p>Approximately 5V★</p>  <p style="text-align: right; font-size: small;">PBIB1584E</p>
16	BR	A/F sensor 1 (Bank 1)	<p>[Engine is running]</p> <ul style="list-style-type: none"> ● Warm-up condition ● Idle speed 	Approximately 3.1V
35	O/B			Approximately 2.6V
56	V			Approximately 2.3V
75	P			Approximately 2.3V
21 22 23	L/W R/Y R/B	Fuel injector No. 5 Fuel injector No. 3 Fuel injector No. 1	<p>[Engine is running]</p> <ul style="list-style-type: none"> ● Warm-up condition ● Idle speed <p>NOTE: The pulse cycle changes depending on rpm at idle</p>	<p>BATTERY VOLTAGE (11 - 14V)★</p>  <p style="text-align: right; font-size: small;">SEC984C</p>
			<p>[Engine is running]</p> <ul style="list-style-type: none"> ● Warm-up condition ● Engine speed: 2,000 rpm 	<p>BATTERY VOLTAGE (11 - 14V)★</p>  <p style="text-align: right; font-size: small;">SEC986C</p>

★: Average voltage for pulse signal (Actual pulse signal can be confirmed by oscilloscope.)

DTC P0171, P0174 FUEL INJECTION SYSTEM FUNCTION

BANK 2

EC-FUELB2-01

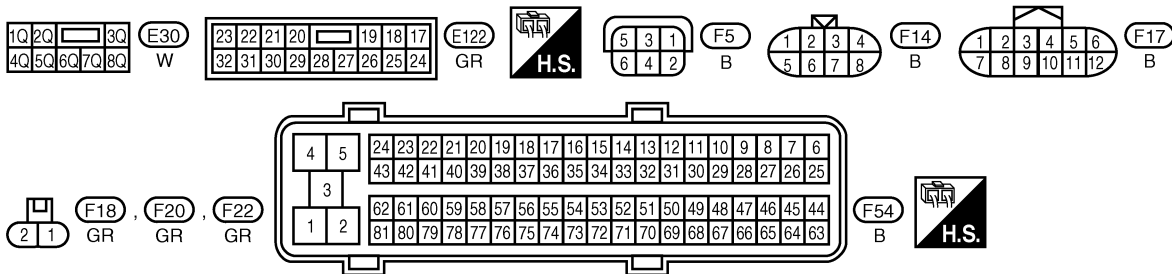
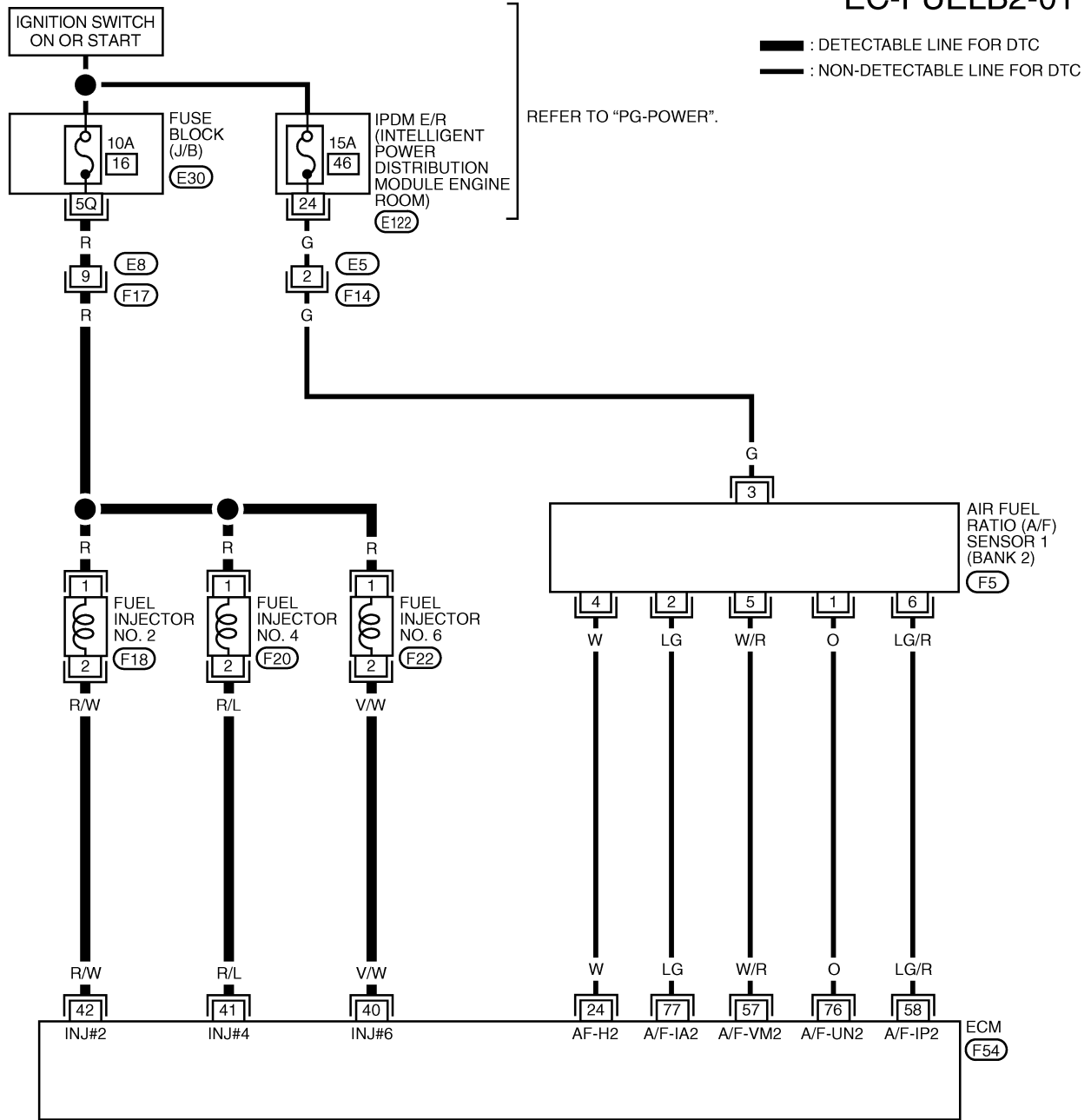

BBWA2515E

DTC P0171, P0174 FUEL INJECTION SYSTEM FUNCTION

Specification data are reference values and are measured between each terminal and ground.
Pulse signal is measured by CONSULT-II.

CAUTION:

Do not use ECM ground terminals when measuring input/output voltage. Doing so may result in damage to the ECM's transistor. Use a ground other than ECM terminals, such as the ground.

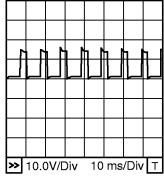
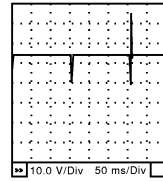
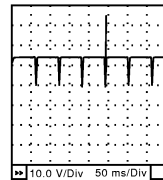
TERMI- NAL NO.	WIRE COLOR	ITEM	CONDITION	DATA (DC Voltage)
24	W	A/F sensor 1 heater (Bank 2)	<p>[Engine is running]</p> <ul style="list-style-type: none"> ● Warm-up condition ● Idle speed 	<p>Approximately 5V★</p>  <p style="text-align: right; font-size: small;">PBIB1584E</p>
40 41 42	V/W R/L R/W	Fuel injector No. 6 Fuel injector No. 4 Fuel injector No. 2	<p>[Engine is running]</p> <ul style="list-style-type: none"> ● Warm-up condition ● Idle speed <p>NOTE: The pulse cycle changes depending on rpm at idle</p>	<p>BATTERY VOLTAGE (11 - 14V)★</p>  <p style="text-align: right; font-size: small;">SEC984C</p>
			<p>[Engine is running]</p> <ul style="list-style-type: none"> ● Warm-up condition ● Engine speed: 2,000 rpm 	<p>BATTERY VOLTAGE (11 - 14V)★</p>  <p style="text-align: right; font-size: small;">SEC985C</p>
57 58 76 77	W/R LG/R O LG	A/F sensor 1 (Bank 2)	<p>[Engine is running]</p> <ul style="list-style-type: none"> ● Warm-up condition ● Idle speed 	<p>Approximately 2.6V</p> <hr/> <p>Approximately 2.3V</p> <hr/> <p>Approximately 3.1V</p> <hr/> <p>Approximately 2.3V</p>

★: Average voltage for pulse signal (Actual pulse signal can be confirmed by oscilloscope.)

DTC P0171, P0174 FUEL INJECTION SYSTEM FUNCTION

Diagnostic Procedure

UBS00P6H

1. CHECK EXHAUST GAS LEAK

1. Start engine and run it at idle.
2. Listen for an exhaust gas leak before three way catalyst (manifold).

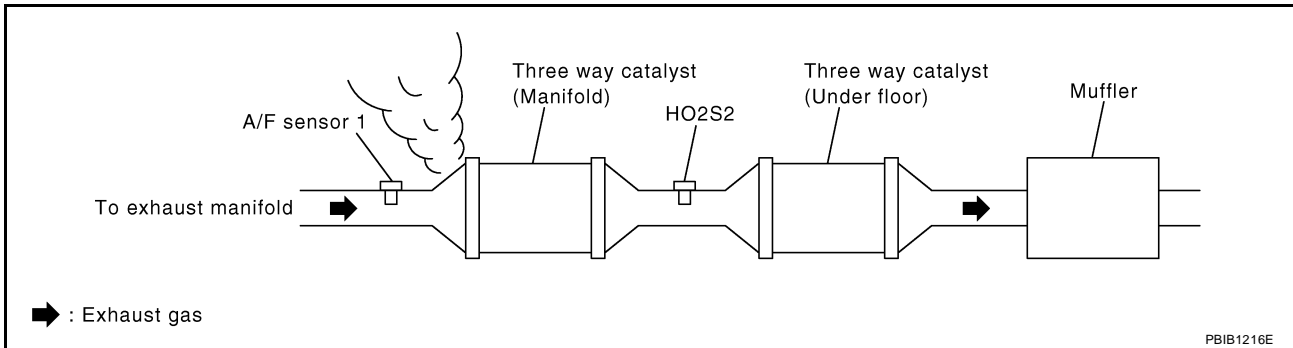

OK or NG

- OK >> GO TO 2.
- NG >> Repair or replace.

2. CHECK FOR INTAKE AIR LEAK

1. Listen for an intake air leak after the mass air flow sensor.
2. Check PCV hose connection.

OK or NG

- OK >> GO TO 3.
- NG >> Repair or replace.

DTC P0171, P0174 FUEL INJECTION SYSTEM FUNCTION

3. CHECK A/F SENSOR 1 INPUT SIGNAL CIRCUIT

1. Turn ignition switch OFF.
2. Disconnect corresponding A/F sensor 1 harness connector.

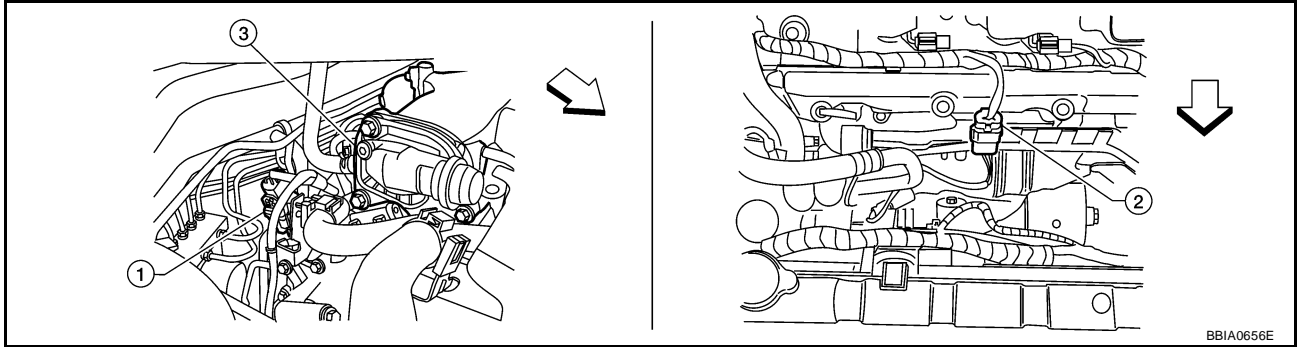

↙ Vehicle front

1. Air fuel ratio (A/F) sensor 1 (bank 1) harness connector
2. Air fuel ratio (A/F) sensor 1 (bank 2) harness connector
3. Intake manifold collector harness connector

3. Disconnect ECM harness connector.
4. Check harness continuity between the following terminals.
Refer to Wiring Diagram.

	A/F sensor 1 terminal	ECM terminal
Bank 1	1	16
	2	75
	5	35
	6	56
Bank 2	1	76
	2	77
	5	57
	6	58

Continuity should exist.

5. Check harness continuity between the following terminals and ground.
Refer to Wiring Diagram.

Bank 1		Bank 2	
A/F sensor 1 terminal	ECM terminal	A/F sensor 1 terminal	ECM terminal
1	16	1	76
2	75	2	77
5	35	5	57
6	56	6	58

Continuity should not exist.

6. Also check harness for short to power.

OK or NG

OK >> GO TO 4.

NG >> Repair open circuit or short to ground or short to power in harness or connectors.

DTC P0171, P0174 FUEL INJECTION SYSTEM FUNCTION

4. CHECK FUEL PRESSURE

1. Release fuel pressure to zero. Refer to [EC-82, "FUEL PRESSURE RELEASE"](#) .
2. Install fuel pressure gauge and check fuel pressure. Refer to [EC-83, "FUEL PRESSURE CHECK"](#) .

At idling: Approximately 350 kPa (3.57 kg/cm² , 51 psi)

OK or NG

- OK (With CONSULT-II)>>GO TO 6.
- OK (Without CONSULT-II)>>GO TO 7.
- NG >> GO TO 5.

5. DETECT MALFUNCTIONING PART

Check the following.

- Fuel pump and circuit (Refer to [EC-685, "FUEL PUMP"](#) .)
- Fuel pressure regulator (Refer to [EC-83, "FUEL PRESSURE CHECK"](#) .)
- Fuel lines
- Fuel filter for clogging

>> Repair or replace.

6. CHECK MASS AIR FLOW SENSOR

 **With CONSULT-II**

1. Install all removed parts.
2. Check "MASS AIR FLOW" in "DATA MONITOR" mode with CONSULT-II.

2.0 - 6.0 g-m/sec: at idling
7.0 - 20.0 g-m/sec: at 2,500 rpm

OK or NG

- OK >> GO TO 8.
- NG >> Check connectors for rusted terminals or loose connections in the mass air flow sensor circuit or ground. Refer to [EC-192, "DTC P0101 MAF SENSOR"](#) .

7. CHECK MASS AIR FLOW SENSOR

 **With GST**

1. Install all removed parts.
2. Check mass air flow sensor signal in Service \$01 with GST.

2.0 - 6.0 g-m/sec: at idling
7.0 - 20.0 g-m/sec: at 2,500 rpm

OK or NG

- OK (P0171)>>GO TO 9.
- OK (P0174)>>GO TO 11.
- NG >> Check connectors for rusted terminals or loose connections in the mass air flow sensor circuit or ground. Refer to [EC-192, "DTC P0101 MAF SENSOR"](#) .

DTC P0171, P0174 FUEL INJECTION SYSTEM FUNCTION

8. CHECK FUNCTION OF FUEL INJECTOR

With CONSULT-II

1. Start engine.
2. Perform "POWER BALANCE" in "ACTIVE TEST" mode with CONSULT-II.
3. Make sure that each circuit produces a momentary engine speed drop.

ACTIVE TEST	
POWER BALANCE	
MONITOR	
ENG SPEED	XXX rpm
MAS A/F SE-B1	XXX V

PBIB0133E

OK or NG

OK >> GO TO 12.

NG >> Perform trouble diagnosis for FUEL INJECTOR, refer to [EC-678, "FUEL INJECTOR"](#).

A

EC

C

D

E

F

G

H

I

J

K

L

M

DTC P0171, P0174 FUEL INJECTION SYSTEM FUNCTION

9. CHECK FUNCTION OF FUEL INJECTOR-I

⊗ Without CONSULT-II

1. Stop engine.
2. Disconnect harness connector F44 (2), F101 (3)
3. Turn ignition switch ON.
 - ↖: Vehicle front
 - Intake manifold collector (1)

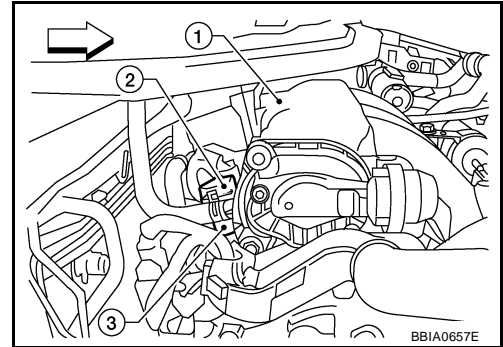

4. Check voltage between harness connector F44 terminal 5 and ground with CONSULT-II or tester.

Voltage: Battery voltage

5. Turn ignition switch OFF.
6. Disconnect ECM harness connector.
7. Check harness continuity between harness connector F44 terminal and ECM terminal as follows. Refer to Wiring Diagram.

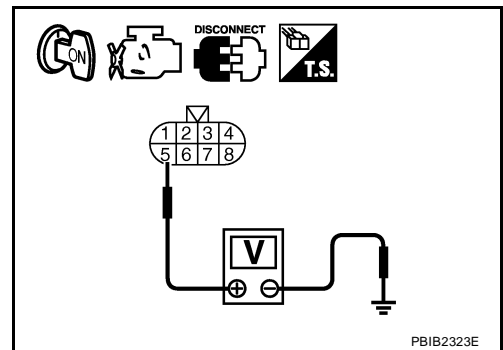

Cylinder	Harness connector F44 terminal	ECM terminal
1	6	23
3	2	22
5	1	21

Continuity should exist.

8. Also check harness for short to ground and short to power.

OK or NG

OK >> GO TO 10.

NG >> Perform trouble diagnosis for FUEL INJECTOR, refer to [EC-678. "FUEL INJECTOR"](#) .

10. CHECK FUNCTION OF FUEL INJECTOR-II

Provide battery voltage between harness connector F101 as follows and then interrupt it. Listen to each fuel injector operating sound.

Cylinder	Harness connector F101 terminal	
	(+)	(-)
1	5	6
3	5	2
5	5	1

Operating sound should exist.

OK or NG

OK >> GO TO 12.

NG >> Perform trouble diagnosis for FUEL INJECTOR, refer to [EC-678. "FUEL INJECTOR"](#) .

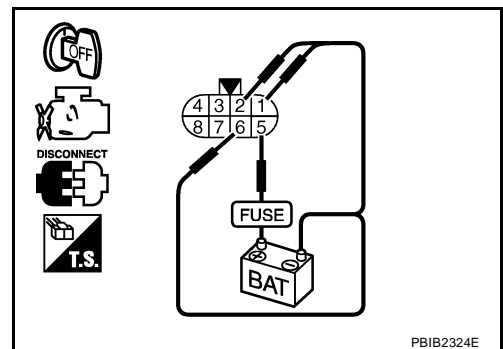

DTC P0171, P0174 FUEL INJECTION SYSTEM FUNCTION

11. CHECK FUNCTION OF FUEL INJECTOR

1. Start engine.
2. Listen to fuel injectors No.2, No.4, No.6 operating sound.

Clicking noise should exist.

OK or NG

OK >> GO TO 12.

NG >> Perform trouble diagnosis for FUEL INJECTOR, refer to [EC-678, "FUEL INJECTOR"](#) .

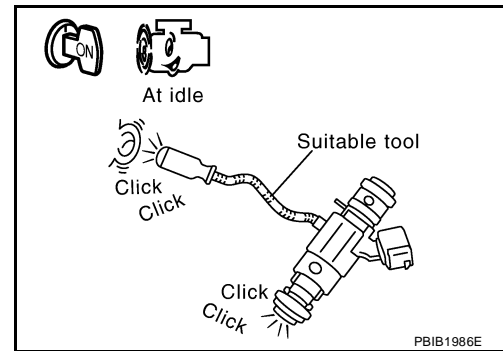

12. CHECK FUEL INJECTOR

1. Confirm that the engine is cooled down and there are no fire hazards near the vehicle.
2. Turn ignition switch OFF.
3. Reconnect all harness connectors disconnected.
4. Disconnect all fuel injector harness connectors.
5. Remove fuel tube assembly. Refer to [EM-40, "FUEL INJECTOR AND FUEL TUBE"](#) .
Keep fuel hose and all fuel injectors connected to fuel tube.
6. For DTC P0171, reconnect fuel injector harness connectors on bank 1.
For DTC P0174, reconnect fuel injector harness connectors on bank 2.
7. Disconnect all ignition coil harness connectors.
8. Prepare pans or saucers under each fuel injector.
9. Crank engine for about 3 seconds.
For DTC P0171, make sure that fuel sprays out from fuel injectors on bank 1.
For DTC P0174, make sure that fuel sprays out from fuel injectors on bank 2.

Fuel should be sprayed evenly for each fuel injector.

OK or NG

OK >> GO TO 13.

NG >> Replace fuel injectors from which fuel does not spray out. Always replace O-ring with new ones.

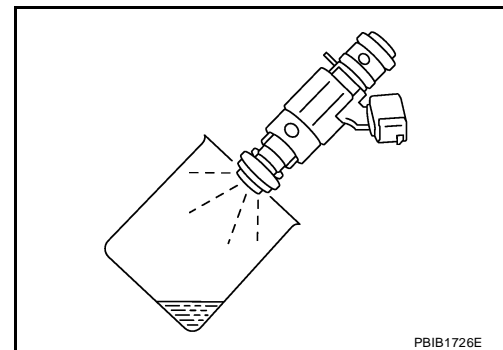

13. CHECK INTERMITTENT INCIDENT

Refer to [EC-149, "TROUBLE DIAGNOSIS FOR INTERMITTENT INCIDENT"](#) .

>> INSPECTION END

DTC P0172, P0175 FUEL INJECTION SYSTEM FUNCTION

DTC P0172, P0175 FUEL INJECTION SYSTEM FUNCTION

PF1:16600

On Board Diagnosis Logic

UBS00P6I

With the Air/Fuel Mixture Ratio Self-Learning Control, the actual mixture ratio can be brought closely to the theoretical mixture ratio based on the mixture ratio feedback signal from the A/F sensors 1. The ECM calculates the necessary compensation to correct the offset between the actual and the theoretical ratios.

In case the amount of the compensation value is extremely large (The actual mixture ratio is too rich.), the ECM judges the condition as the fuel injection system malfunction and lights up the MIL (2 trip detection logic).

Sensor	Input signal to ECM	ECM function	Actuator
A/F sensors 1	Density of oxygen in exhaust gas (Mixture ratio feedback signal)	Fuel injection control	Fuel injector

DTC No.	Trouble diagnosis name	DTC detecting condition	Possible cause
P0172 0172 (Bank 1)	Fuel injection system too rich	<ul style="list-style-type: none"> Fuel injection system does not operate properly. The amount of mixture ratio compensation is too large. (The mixture ratio is too rich.) 	<ul style="list-style-type: none"> A/F sensor 1 Fuel injector Exhaust gas leaks Incorrect fuel pressure Mass air flow sensor
P0175 0175 (Bank 2)			

DTC Confirmation Procedure

UBS00P6J

NOTE:

If DTC Confirmation Procedure has been previously conducted, always turn ignition switch OFF and wait at least 10 seconds before conducting the next test.

④ WITH CONSULT-II

- Start engine and warm it up to normal operating temperature.
- Turn ignition switch OFF and wait at least 10 seconds.
- Turn ignition switch ON and select "SELF-LEARNING CONT" in "WORK SUPPORT" mode with CONSULT-II.
- Clear the self-learning control coefficient by touching "CLEAR".
- Select "DATA MONITOR" mode with CONSULT-II.
- Start engine again and let it idle for at least 10 minutes. The 1st trip DTC P0172, P0175 should be detected at this stage, if a malfunction exists. If so, go to [EC-340, "Diagnostic Procedure"](#).

NOTE:

If 1st trip DTC is not detected during above procedure, performing the following procedure is advised.

- Turn ignition switch OFF and wait at least 10 seconds.
- Start engine and drive the vehicle under the similar conditions to (1st trip) Freeze Frame Data for 10 minutes. Refer to the table below.
Hold the accelerator pedal as steady as possible.

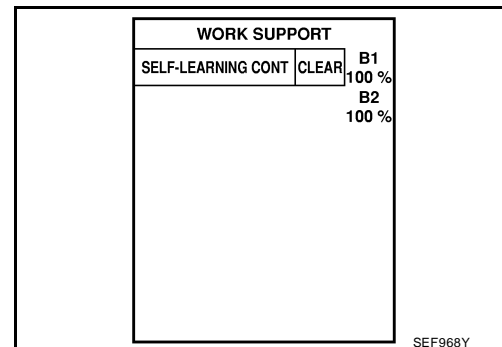

The similar conditions to (1st trip) Freeze Frame Data means the vehicle operation that the following conditions should be satisfied at the same time.

Engine speed	Engine speed in the freeze frame data \pm 400 rpm
Vehicle speed	Vehicle speed in the freeze frame data \pm 10 km/h (6 MPH)
Engine coolant temperature (T) condition	When the freeze frame data shows lower than 70 °C (158 °F), T should be lower than 70 °C (158 °F).
	When the freeze frame data shows higher than or equal to 70 °C (158 °F), T should be higher than or equal to 70 °C (158 °F).

- If it is difficult to start engine at step 6, the fuel injection system has a malfunction, too.
- Crank engine while depressing accelerator pedal.

DTC P0172, P0175 FUEL INJECTION SYSTEM FUNCTION

If engine starts, go to [EC-340, "Diagnostic Procedure"](#) . If engine does not start, remove spark plugs and check for fouling, etc.

WITH GST

1. Start engine and warm it up to normal operating temperature.
2. Turn ignition switch OFF and wait at least 10 seconds.
3. Disconnect mass air flow sensor harness connector. Then restart and run engine for at least 5 seconds at idle speed.
4. Stop engine and reconnect mass air flow sensor harness connector.
5. Select Service \$03 with GST. Make sure DTC P0102 is detected.
6. Select Service \$04 with GST and erase the DTC P0102.
7. Start engine again and let it idle for at least 10 minutes.
8. Select Service \$07 with GST. The 1st trip DTC P0172 or P0175 should be detected at this stage, if a malfunction exists. If so, go to [EC-340, "Diagnostic Procedure"](#) .

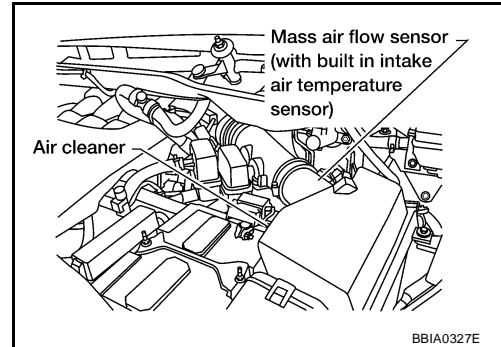

NOTE:

If 1st trip DTC is not detected during above procedure, performing the following procedure is advised.

- a. Turn ignition switch OFF and wait at least 10 seconds.
- b. Start engine and drive the vehicle under the similar conditions to (1st trip) Freeze Frame Data for 10 minutes. Refer to the table below.

Hold the accelerator pedal as steady as possible.

The similar conditions to (1st trip) Freeze Frame Data means the vehicle operation that the following conditions should be satisfied at the same time.

Engine speed	Engine speed in the freeze frame data \pm 400 rpm
Vehicle speed	Vehicle speed in the freeze frame data \pm 10 km/h (6 MPH)
Engine coolant temperature (T) condition	When the freeze frame data shows lower than 70 °C (158 °F), T should be lower than 70 °C (158 °F).
	When the freeze frame data shows higher than or equal to 70 °C (158 °F), T should be higher than or equal to 70 °C (158 °F).

9. If it is difficult to start engine at step 7, the fuel injection system has a malfunction.
10. Crank engine while depressing accelerator pedal.
If engine starts, go to [EC-340, "Diagnostic Procedure"](#) . If engine does not start, remove spark plugs and check for fouling, etc.

DTC P0172, P0175 FUEL INJECTION SYSTEM FUNCTION

UBS00P6K

Wiring Diagram BANK 1

EC-FUELB1-01

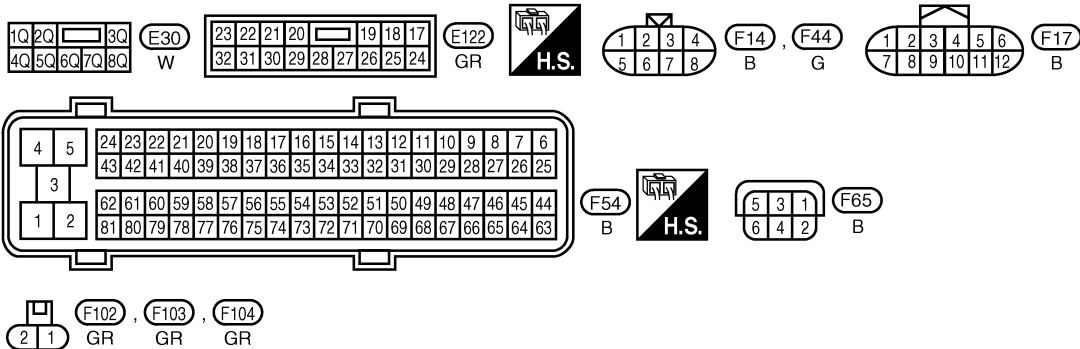
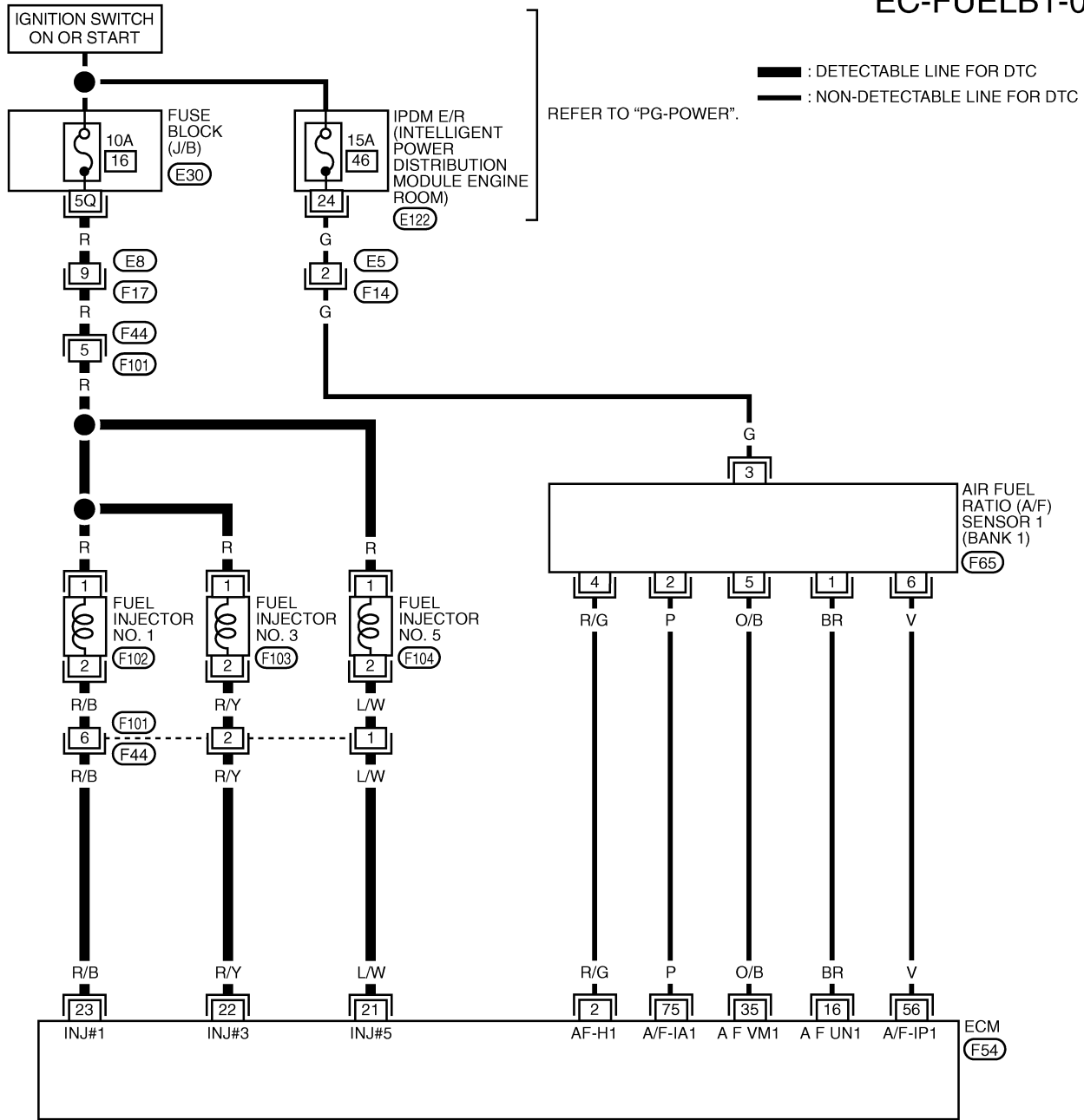

BBWA2514E

DTC P0172, P0175 FUEL INJECTION SYSTEM FUNCTION

Specification data are reference values and are measured between each terminal and ground.
Pulse signal is measured by CONSULT-II.

CAUTION:

Do not use ECM ground terminals when measuring input/output voltage. Doing so may result in damage to the ECM's transistor. Use a ground other than ECM terminals, such as the ground.

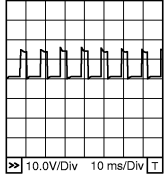
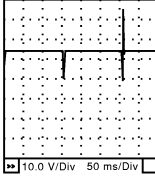
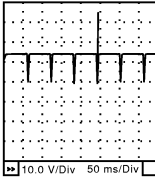
TERMI- NAL NO.	WIRE COLOR	ITEM	CONDITION	DATA (DC Voltage)
2	R/G	A/F sensor 1 heater (Bank 1)	[Engine is running] <ul style="list-style-type: none"> ● Warm-up condition ● Idle speed 	Approximately 5V★  <small>PBIB1584E</small>
16	BR	A/F sensor 1 (Bank 1)	[Engine is running] <ul style="list-style-type: none"> ● Warm-up condition ● Idle speed 	Approximately 3.1V
35	O/B			Approximately 2.6V
56	V			Approximately 2.3V
75	P			Approximately 2.3V
21 22 23	L/W R/Y R/B	Fuel injector No. 5 Fuel injector No. 3 Fuel injector No. 1	[Engine is running] <ul style="list-style-type: none"> ● Warm-up condition ● Idle speed NOTE: The pulse cycle changes depending on rpm at idle	BATTERY VOLTAGE (11 - 14V)★  <small>SEC984C</small>
			[Engine is running] <ul style="list-style-type: none"> ● Warm-up condition ● Engine speed: 2,000 rpm 	BATTERY VOLTAGE (11 - 14V)★  <small>SEC986C</small>

★: Average voltage for pulse signal (Actual pulse signal can be confirmed by oscilloscope.)

DTC P0172, P0175 FUEL INJECTION SYSTEM FUNCTION

BANK 2

EC-FUELB2-01

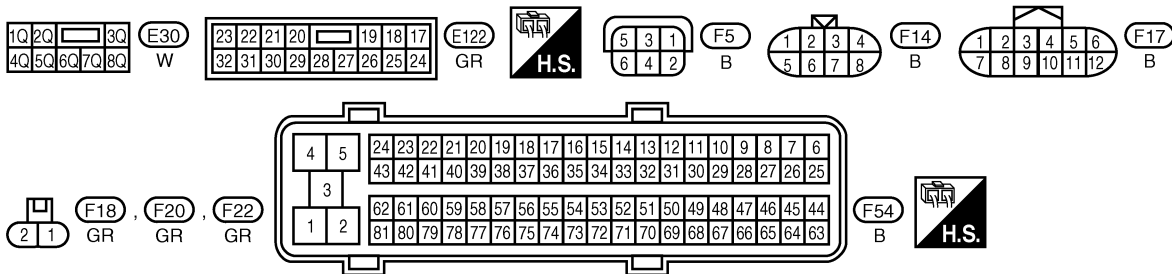
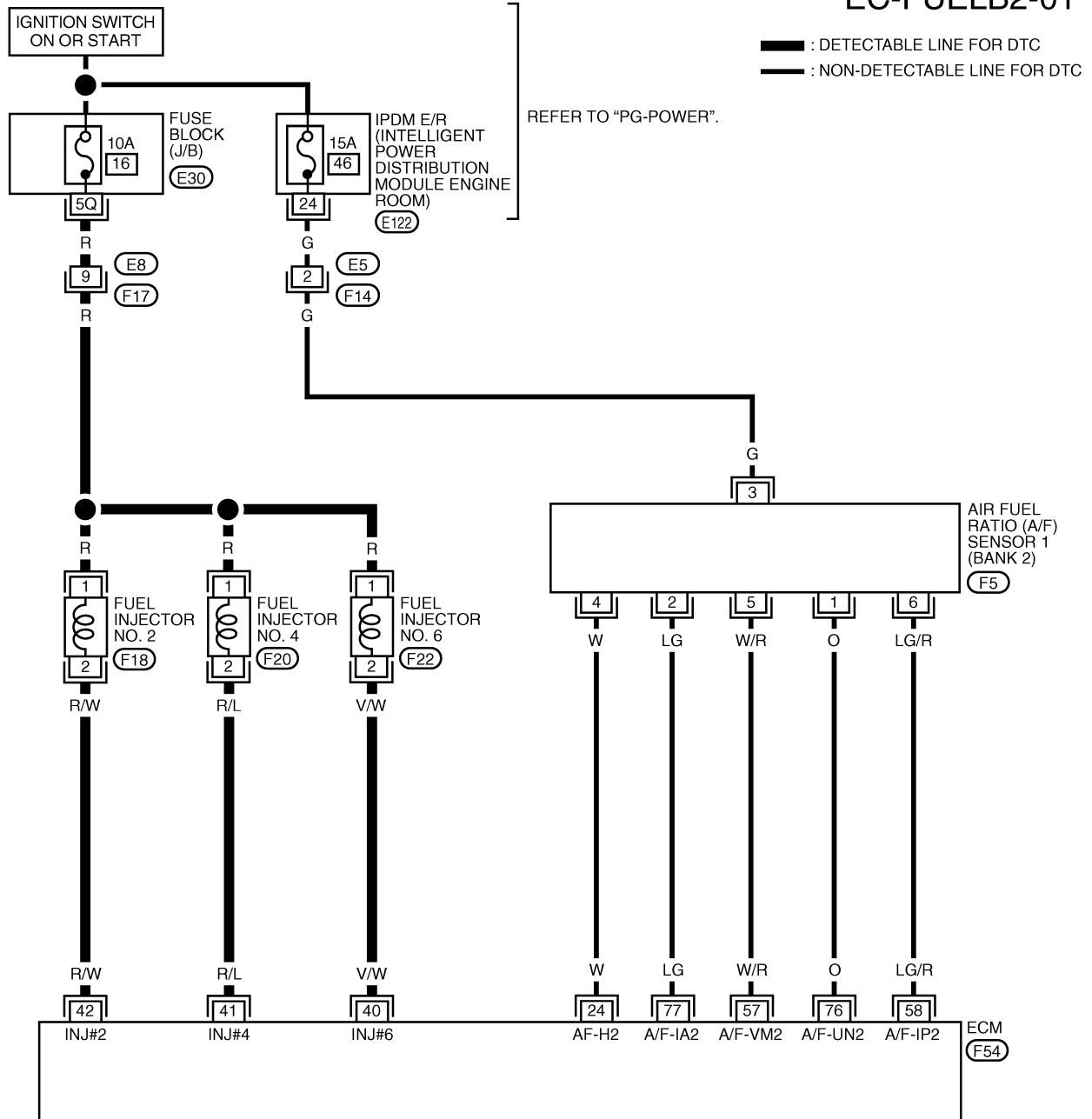

BBWA2515E

DTC P0172, P0175 FUEL INJECTION SYSTEM FUNCTION

Specification data are reference values and are measured between each terminal and ground.
Pulse signal is measured by CONSULT-II.

CAUTION:

Do not use ECM ground terminals when measuring input/output voltage. Doing so may result in damage to the ECM's transistor. Use a ground other than ECM terminals, such as the ground.

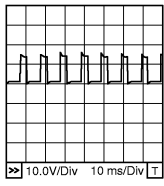
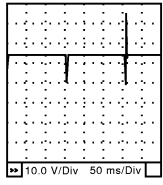
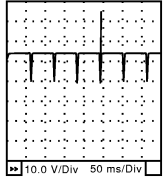
TERMI- NAL NO.	WIRE COLOR	ITEM	CONDITION	DATA (DC Voltage)
24	W	A/F sensor 1 heater (Bank 2)	<p>[Engine is running]</p> <ul style="list-style-type: none"> ● Warm-up condition ● Idle speed 	<p>Approximately 5V★</p>  <p style="text-align: right;">PBIB1584E</p>
40 41 42	V/W R/L R/W	Fuel injector No. 6 Fuel injector No. 4 Fuel injector No. 2	<p>[Engine is running]</p> <ul style="list-style-type: none"> ● Warm-up condition ● Idle speed <p>NOTE: The pulse cycle changes depending on rpm at idle</p>	<p>BATTERY VOLTAGE (11 - 14V)★</p>  <p style="text-align: right;">SEC984C</p>
			<p>[Engine is running]</p> <ul style="list-style-type: none"> ● Warm-up condition ● Engine speed: 2,000 rpm 	<p>BATTERY VOLTAGE (11 - 14V)★</p>  <p style="text-align: right;">SEC985C</p>
57 58 76 77	W/R LG/R O LG	A/F sensor 1 (Bank 2)	<p>[Engine is running]</p> <ul style="list-style-type: none"> ● Warm-up condition ● Idle speed 	<p>Approximately 2.6V</p> <hr/> <p>Approximately 2.3V</p> <hr/> <p>Approximately 3.1V</p> <hr/> <p>Approximately 2.3V</p>

★: Average voltage for pulse signal (Actual pulse signal can be confirmed by oscilloscope.)

DTC P0172, P0175 FUEL INJECTION SYSTEM FUNCTION

UBS00P6L

Diagnostic Procedure

1. CHECK EXHAUST GAS LEAK

1. Start engine and run it at idle.
2. Listen for an exhaust gas leak before three way catalyst (manifold).

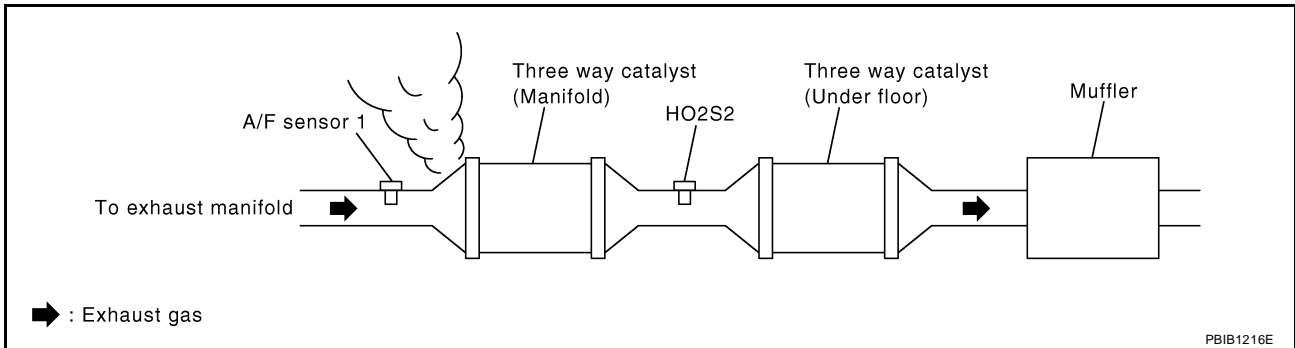

OK or NG

- OK >> GO TO 2.
- NG >> Repair or replace.

2. CHECK FOR INTAKE AIR LEAK

Listen for an intake air leak after the mass air flow sensor.

OK or NG

- OK >> GO TO 3.
- NG >> Repair or replace.

DTC P0172, P0175 FUEL INJECTION SYSTEM FUNCTION

3. CHECK A/F SENSOR 1 INPUT SIGNAL CIRCUIT

1. Turn ignition switch OFF.
2. Disconnect corresponding A/F sensor 1 harness connector.

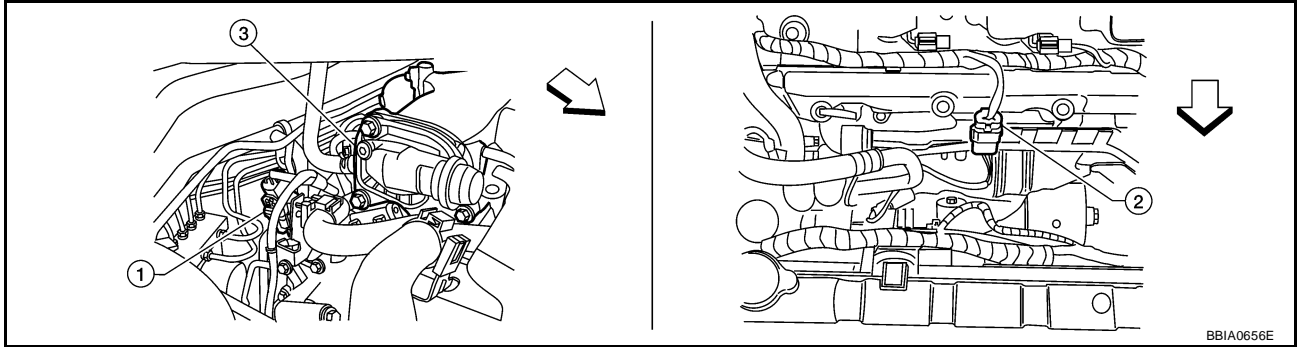

↙ Vehicle front

1. Air fuel ratio (A/F) sensor 1 (bank 1) harness connector
2. Air fuel ratio (A/F) sensor 1 (bank 2) harness connector
3. Intake manifold collector harness connector

3. Disconnect ECM harness connector.
4. Check harness continuity between the following terminals.
Refer to Wiring Diagram.

	A/F sensor 1 terminal	ECM terminal
Bank 1	1	16
	2	75
	5	35
	6	56
Bank 2	1	76
	2	77
	5	57
	6	58

Continuity should exist.

5. Check harness continuity between the following terminals and ground.
Refer to Wiring Diagram.

Bank 1		Bank 2	
A/F sensor 1 terminal	ECM terminal	A/F sensor 1 terminal	ECM terminal
1	16	1	76
2	75	2	77
5	35	5	57
6	56	6	58

Continuity should not exist.

6. Also check harness for short to power.

OK or NG

OK >> GO TO 4.

NG >> Repair open circuit or short to ground or short to power in harness or connectors.

DTC P0172, P0175 FUEL INJECTION SYSTEM FUNCTION

4. CHECK FUEL PRESSURE

1. Release fuel pressure to zero. Refer to [EC-82, "FUEL PRESSURE RELEASE"](#) .
2. Install fuel pressure gauge and check fuel pressure. Refer to [EC-83, "FUEL PRESSURE CHECK"](#) .

**At idling: Approximately 350 kPa (3.57 kg/cm² ,
51 psi)**

OK or NG

- OK (With CONSULT-II)>>GO TO 6.
OK (Without CONSULT-II)>>GO TO 7.
NG >> GO TO 5.

5. DETECT MALFUNCTIONING PART

Check the following.

- Fuel pump and circuit (Refer to, [EC-685, "FUEL PUMP"](#) .)
- Fuel pressure regulator (Refer to [EC-83, "FUEL PRESSURE CHECK"](#) .)

>> Repair or replace.

6. CHECK MASS AIR FLOW SENSOR

With CONSULT-II

1. Install all removed parts.
2. Check "MASS AIR FLOW" in "DATA MONITOR" mode with CONSULT-II.

2.0 - 6.0 g-m/sec: at idling
7.0 - 20.0 g-m/sec: at 2,500 rpm

OK or NG

- OK >> GO TO 8.
NG >> Check connectors for rusted terminals or loose connections in the mass air flow sensor circuit or ground. Refer to [EC-192, "DTC P0101 MAF SENSOR"](#) .

7. CHECK MASS AIR FLOW SENSOR

With GST

1. Install all removed parts.
2. Check mass air flow sensor signal in Service \$01 with GST.

2.0 - 6.0 g-m/sec: at idling
7.0 - 20.0 g-m/sec: at 2,500 rpm

OK or NG

- OK (P0172)>>GO TO 9.
OK (P0175)>>GO TO 11.
NG >> Check connectors for rusted terminals or loose connections in the mass air flow sensor circuit or ground. Refer to [EC-192, "DTC P0101 MAF SENSOR"](#) .

DTC P0172, P0175 FUEL INJECTION SYSTEM FUNCTION

8. CHECK FUNCTION OF FUEL INJECTOR

With CONSULT-II

1. Start engine.
2. Perform "POWER BALANCE" in "ACTIVE TEST" mode with CONSULT-II.
3. Make sure that each circuit produces a momentary engine speed drop.

ACTIVE TEST	
POWER BALANCE	
MONITOR	
ENG SPEED	XXX rpm
MAS A/F SE-B1	XXX V

PBIB0133E

OK or NG

OK >> GO TO 12.

NG >> Perform trouble diagnosis for FUEL INJECTOR, refer to [EC-678, "FUEL INJECTOR"](#).

A

EC

C

D

E

F

G

H

I

J

K

L

M

DTC P0172, P0175 FUEL INJECTION SYSTEM FUNCTION

9. CHECK FUNCTION OF FUEL INJECTOR-I

⊗ Without CONSULT-II

1. Stop engine.
2. Disconnect harness connector F44 (2), F101 (3)
3. Turn ignition switch ON.
 - ↶: Vehicle front
 - Intake manifold collector (1)

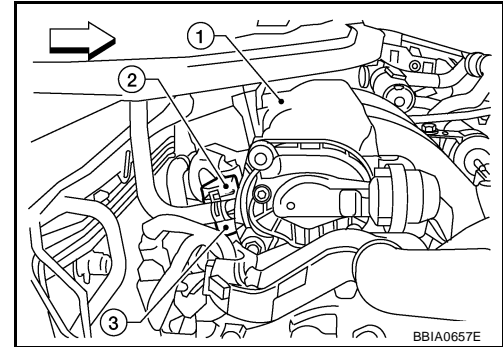

4. Check voltage between harness connector F44 terminal 5 and ground with CONSULT-II or tester.

Voltage: Battery voltage

5. Turn ignition switch OFF.
6. Disconnect ECM harness connector.
7. Check harness continuity between harness connector F44 terminal and ECM terminal as follows. Refer to Wiring Diagram.

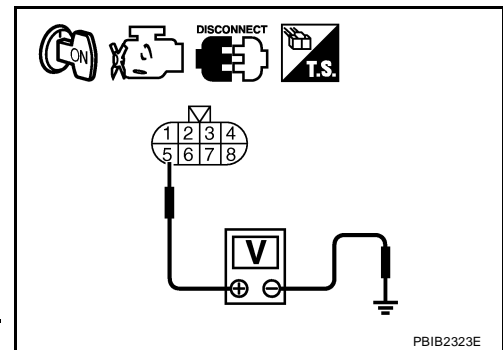

Cylinder	Harness connector F44 terminal	ECM terminal
1	6	23
3	2	22
5	1	21

Continuity should exist.

8. Also check harness for short to ground and short to power.

OK or NG

OK >> GO TO 10.

NG >> Perform trouble diagnosis for FUEL INJECTOR, refer to [EC-678. "FUEL INJECTOR"](#).

10. CHECK FUNCTION OF FUEL INJECTOR-II

Provide battery voltage between harness connector F101 as follows and then interrupt it. Listen to each fuel injector operating sound.

Cylinder	Harness connector F101 terminal	
	(+)	(-)
1	5	6
3	5	2
5	5	1

Operating sound should exist.

OK or NG

OK >> GO TO 12.

NG >> Perform trouble diagnosis for FUEL INJECTOR, refer to [EC-678. "FUEL INJECTOR"](#).

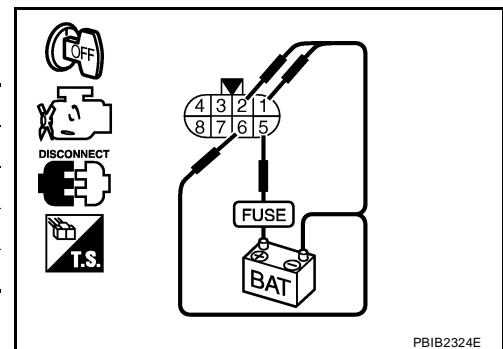

DTC P0172, P0175 FUEL INJECTION SYSTEM FUNCTION

11. CHECK FUNCTION OF FUEL INJECTOR

1. Start engine.
2. Listen to fuel injectors No.2, No.4, No.6 operating sound.

Clicking noise should exist.

OK or NG

OK >> GO TO 12.

NG >> Perform trouble diagnosis for FUEL INJECTOR, refer to [EC-678, "FUEL INJECTOR"](#) .

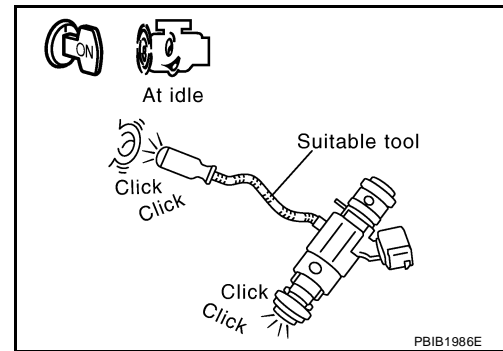

12. CHECK FUEL INJECTOR

1. Remove fuel injector assembly. Refer to [EM-40, "FUEL INJECTOR AND FUEL TUBE"](#) . Keep fuel hose and all fuel injectors connected to fuel tube.
2. Confirm that the engine is cooled down and there are no fire hazards near the vehicle.
3. Reconnect all harness connectors disconnected
4. Disconnect all fuel injector harness connectors.
5. Disconnect all ignition coil harness connectors.
6. Prepare pans or saucers under each fuel injectors.
7. Crank engine for about 3 seconds.
Make sure fuel does not drip from fuel injector.

OK or NG

OK (Does not drip.)>>GO TO 13.

NG (Drips.)>>Replace the fuel injectors from which fuel is dripping. Always replace O-ring with new one.

13. CHECK INTERMITTENT INCIDENT

Refer to [EC-149, "TROUBLE DIAGNOSIS FOR INTERMITTENT INCIDENT"](#) .

>> **INSPECTION END**

DTC P0181 FTT SENSOR

PFP:22630

DTC P0181 FTT SENSOR

Component Description

The fuel tank temperature sensor is used to detect the fuel temperature inside the fuel tank. The sensor modifies a voltage signal from the ECM. The modified signal returns to the ECM as the fuel temperature input. The sensor uses a thermistor which is sensitive to the change in temperature. The electrical resistance of the thermistor decreases as temperature increases.

UBS00P6M

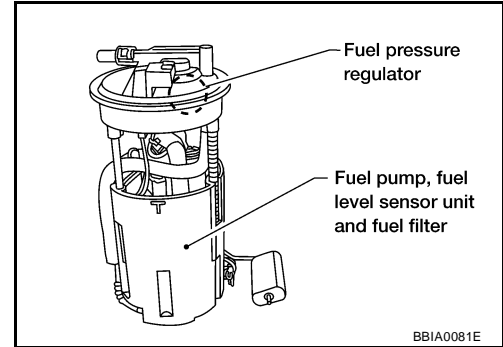

BBIA0081E

<Reference data>

Fluid temperature °C (°F)	Voltage* V	Resistance kΩ
20 (68)	3.5	2.3 - 2.7
50 (122)	2.2	0.79 - 0.90

*: This data is reference value and is measured between ECM terminal 107 (Fuel tank temperature sensor) and ground.

CAUTION:

Do not use ECM ground terminals when measuring input/output voltage. Doing so may result in damage to the ECM's transistor. Use a ground other than ECM terminals, such as the ground.

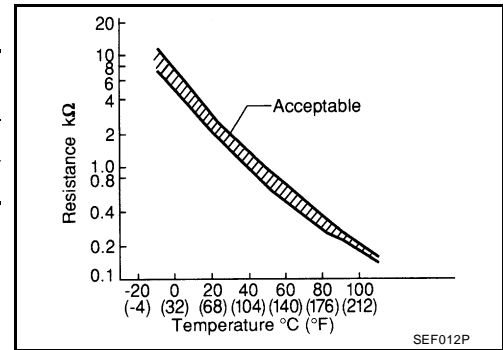

SEF012P

On Board Diagnosis Logic

UBS00P6N

DTC No.	Trouble diagnosis name	DTC detecting condition	Possible cause
P0181 0181	Fuel tank temperature sensor circuit range/performance	Rationally incorrect voltage from the sensor is sent to ECM, compared with the voltage signals from engine coolant temperature sensor and intake air temperature sensor.	<ul style="list-style-type: none"> ● Harness or connectors (The sensor circuit is open or shorted) ● Fuel tank temperature sensor

DTC Confirmation Procedure

UBS00P6O

NOTE:

If DTC Confirmation Procedure has been previously conducted, always turn ignition switch OFF and wait at least 10 seconds before conducting the next test.

WITH CONSULT-II

1. Turn ignition switch ON.
2. Select "DATA MONITOR" mode with CONSULT-II.
3. Wait at least 10 seconds.
If the result is NG, go to [EC-349, "Diagnostic Procedure"](#).
If the result is OK, go to following step.
4. Check "COOLAN TEMP/S" value.
If "COOLAN TEMP/S" is less than 60°C (140°F), the result will be OK.
If "COOLAN TEMP/S" is above 60°C (140°F), go to the following step.
5. Cool engine down until "COOLAN TEMP/S" is less than 60°C (140°F).
6. Wait at least 10 seconds.
7. If 1st trip DTC is detected, go to [EC-349, "Diagnostic Procedure"](#).

DATA MONITOR	
MONITOR	NO DTC
ENG SPEED	XXX rpm
COOLAN TEMP/S	XXX °C

SEF174Y

DTC P0181 FTT SENSOR

 **WITH GST**

Follow the procedure "WITH CONSULT-II" above.

A

EC

C

D

E

F

G

H

I

J

K

L

M

DTC P0181 FTT SENSOR

Wiring Diagram

UBS00P6P

EC-FTTS-01

: DETECTABLE LINE FOR DTC
 : NON-DETECTABLE LINE FOR DTC

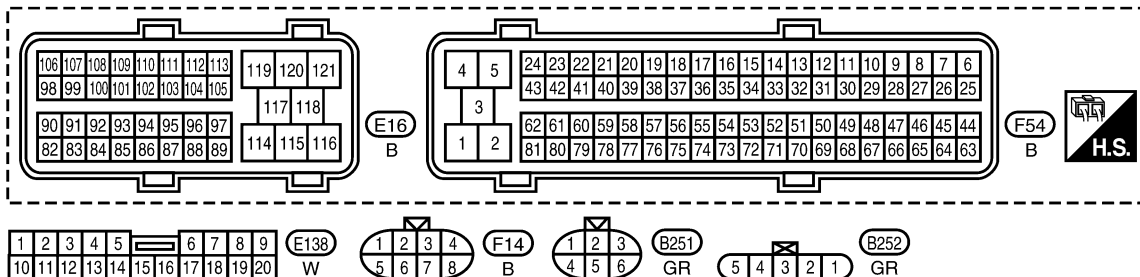
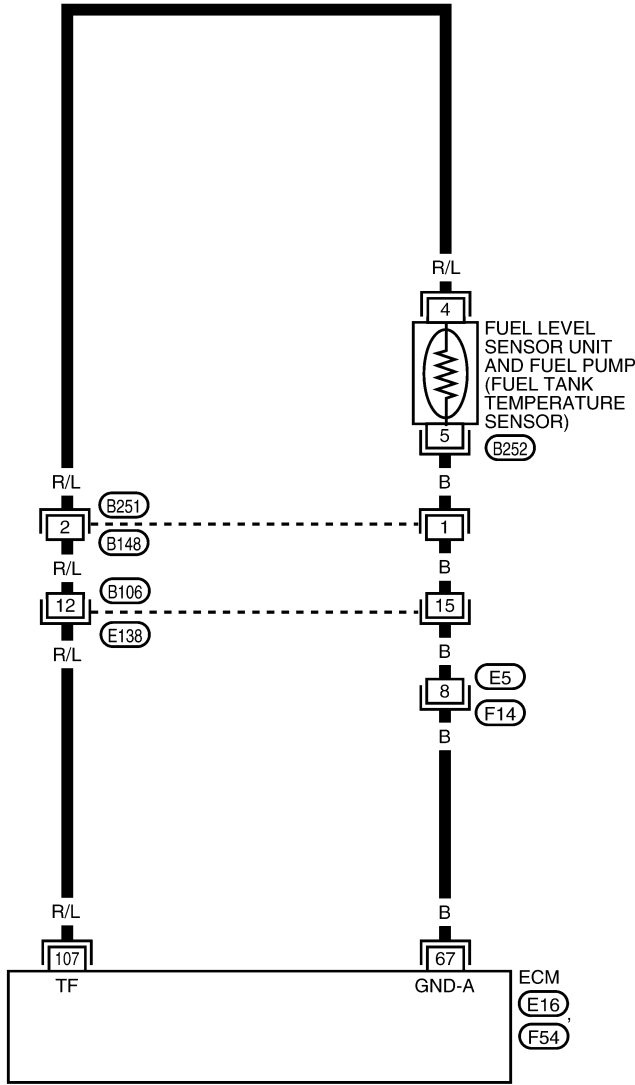

BBWA2516E

DTC P0181 FTT SENSOR

UBS00P6Q

Diagnostic Procedure

1. CHECK GROUND CONNECTIONS

1. Turn ignition switch OFF.
2. Loosen and retighten three ground screws on the body. Refer to [EC-158, "Ground Inspection"](#).

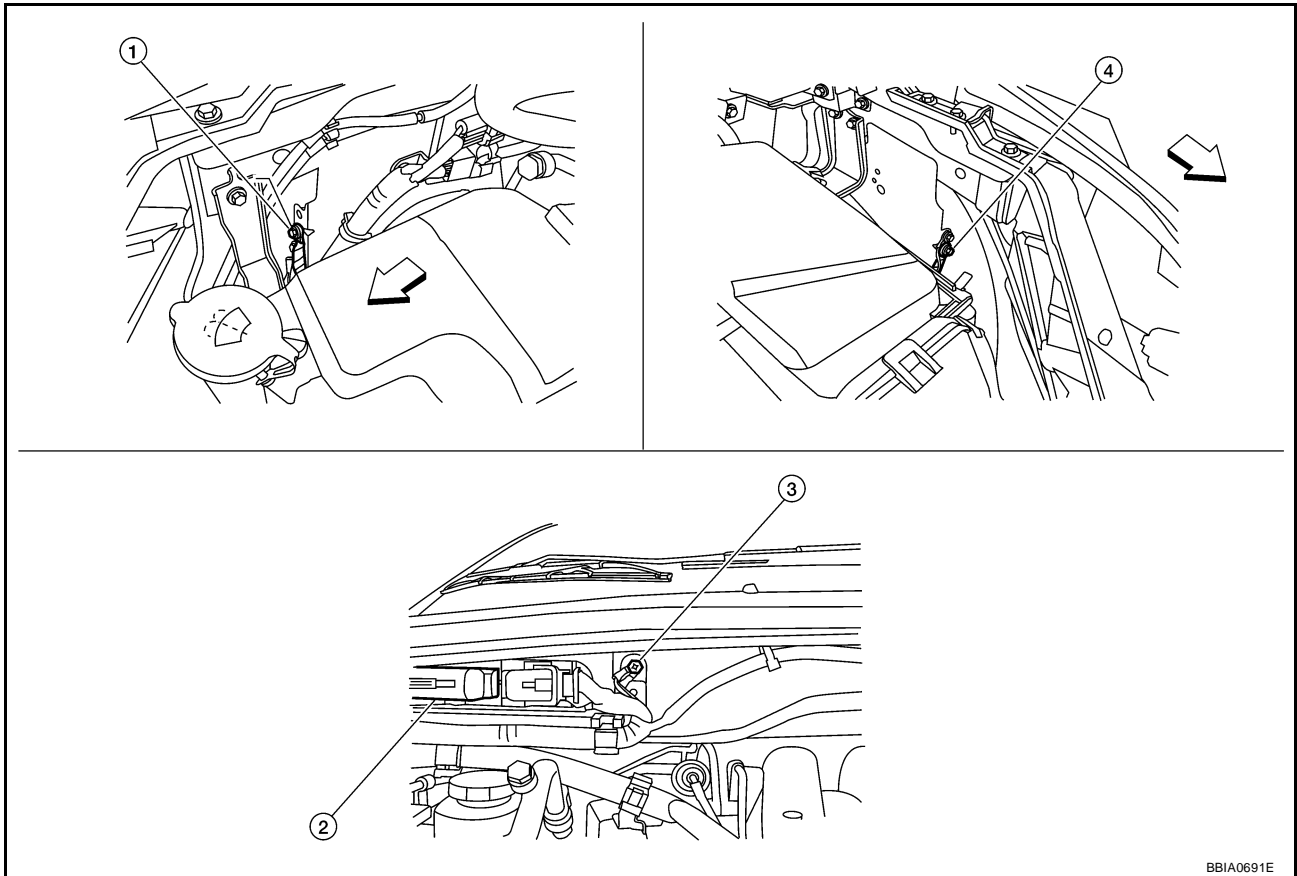

↔ Vehicle front

1. Body ground E24

2. ECM

3. Body ground E9

4. Body ground E15

OK or NG

OK >> GO TO 2.

NG >> Repair or replace ground connections.

DTC P0181 FTT SENSOR

2. CHECK FUEL TANK TEMPERATURE SENSOR POWER SUPPLY CIRCUIT

1. Disconnect “fuel level sensor unit and fuel pump” harness connector (1).
 - ⇐: Vehicle front
2. Turn ignition switch ON.

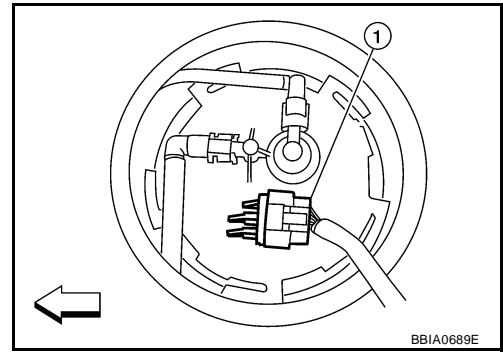

3. Check voltage between “fuel level sensor unit and fuel pump” terminal 4 and ground with CONSULT-II or tester.

Voltage: Approximately 5V

OK or NG

- OK >> GO TO 4.
- NG >> GO TO 3.

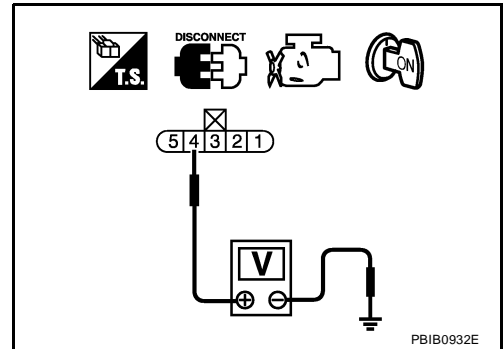

3. DETECT MALFUNCTIONING PART

Check the following.

- Harness connectors B106, E138
- Harness connectors B148, B251
- Harness for open or short between ECM and “fuel level sensor unit and fuel pump”

>> Repair harness or connector.

4. CHECK FUEL TANK TEMPERATURE SENSOR GROUND CIRCUIT FOR OPEN AND SHORT

1. Turn ignition switch OFF.
2. Disconnect ECM harness connector.
3. Check harness continuity between “fuel level sensor unit and fuel pump” terminal 5 and ECM terminal 67. Refer to Wiring Diagram.

Continuity should exist.

4. Also check harness for short to ground and short to power.

OK or NG

- OK >> GO TO 6.
- NG >> GO TO 5.

DTC P0181 FTT SENSOR

5. DETECT MALFUNCTIONING PART

Check the following.

- Harness connectors E5, F14
- Harness connectors B106, E138
- Harness connectors B148, B251
- Harness for open or short between “fuel level sensor unit and fuel pump” and ECM

>> Repair open circuit or short to ground or short to power in harness or connector.

6. CHECK FUEL TANK TEMPERATURE SENSOR

Refer to [EC-351, "Component Inspection"](#) .

OK or NG

OK >> GO TO 7.

NG >> Replace “fuel level sensor unit and fuel pump”.

7. CHECK INTERMITTENT INCIDENT

Refer to [EC-149, "TROUBLE DIAGNOSIS FOR INTERMITTENT INCIDENT"](#) .

>> INSPECTION END

Component Inspection FUEL TANK TEMPERATURE SENSOR

UBS00P6R

1. Remove “fuel level sensor unit and fuel pump”.
2. Check resistance between “fuel level sensor unit and fuel pump” terminals 4 and 5 by heating with hot water or heat gun as shown in the figure.

Temperature °C (°F)	Resistance kΩ
20 (68)	2.3 - 2.7
50 (122)	0.79 - 0.90

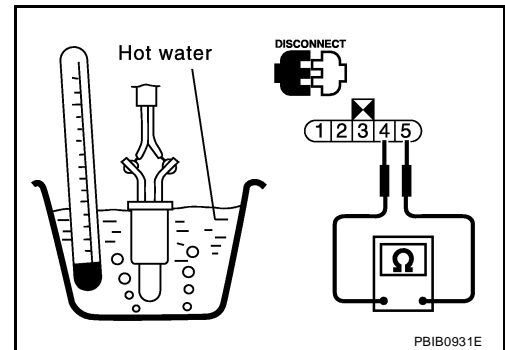

UBS00P6S

Removal and Installation FUEL TANK TEMPERATURE SENSOR

Refer to [FL-5, "FUEL LEVEL SENSOR UNIT, FUEL FILTER AND FUEL PUMP ASSEMBLY"](#) .

DTC P0182, P0183 FTT SENSOR

PF2:22630

DTC P0182, P0183 FTT SENSOR

Component Description

UBS00P6T

The fuel tank temperature sensor is used to detect the fuel temperature inside the fuel tank. The sensor modifies a voltage signal from the ECM. The modified signal returns to the ECM as the fuel temperature input. The sensor uses a thermistor which is sensitive to the change in temperature. The electrical resistance of the thermistor decreases as temperature increases.

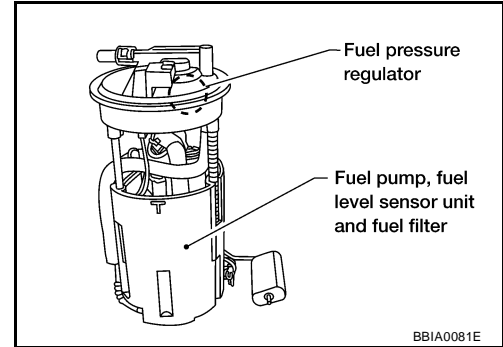

B8IA0081E

<Reference data>

Fluid temperature °C (°F)	Voltage* V	Resistance kΩ
20 (68)	3.5	2.3 - 2.7
50 (122)	2.2	0.79 - 0.90

*: This data is reference value and is measured between ECM terminal 107 (Fuel tank temperature sensor) and ground.

CAUTION:

Do not use ECM ground terminals when measuring input/output voltage. Doing so may result in damage to the ECM's transistor. Use a ground other than ECM terminals, such as the ground.

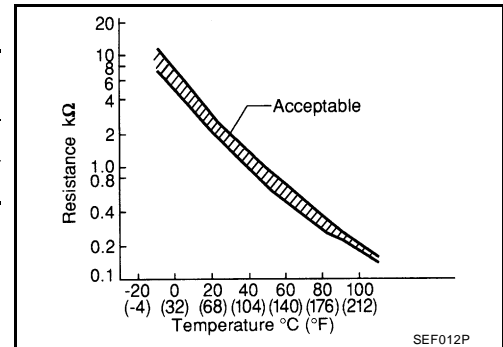

SEF012P

On Board Diagnosis Logic

UBS00P6U

DTC No.	Trouble diagnosis name	DTC detecting condition	Possible cause
P0182 0182	Fuel tank temperature sensor circuit low input	An excessively low voltage from the sensor is sent to ECM.	<ul style="list-style-type: none"> ● Harness or connectors (The sensor circuit is open or shorted.) ● Fuel tank temperature sensor
P0183 0183	Fuel tank temperature sensor circuit high input	An excessively high voltage from the sensor is sent to ECM.	

DTC Confirmation Procedure

UBS00P6V

NOTE:

If DTC Confirmation Procedure has been previously conducted, always turn ignition switch OFF and wait at least 10 seconds before conducting the next test.

WITH CONSULT-II

1. Turn ignition switch ON.
2. Select "DATA MONITOR" mode with CONSULT-II.
3. Wait at least 5 seconds.
4. If 1st trip DTC is detected, go to [EC-354, "Diagnostic Procedure"](#)

The screenshot shows a 'DATA MONITOR' screen with two columns: 'MONITOR' and 'NO DTC'. The 'MONITOR' column displays 'ENG SPEED' and 'COOLANT TEMP/S'. The 'NO DTC' column displays 'XXX rpm' and 'XXX °C'.

SEF174Y

WITH GST

Follow the procedure "WITH CONSULT-II" above.

DTC P0182, P0183 FTT SENSOR

Wiring Diagram

UBS00P6W

EC-FTTS-01

: DETECTABLE LINE FOR DTC
 : NON-DETECTABLE LINE FOR DTC

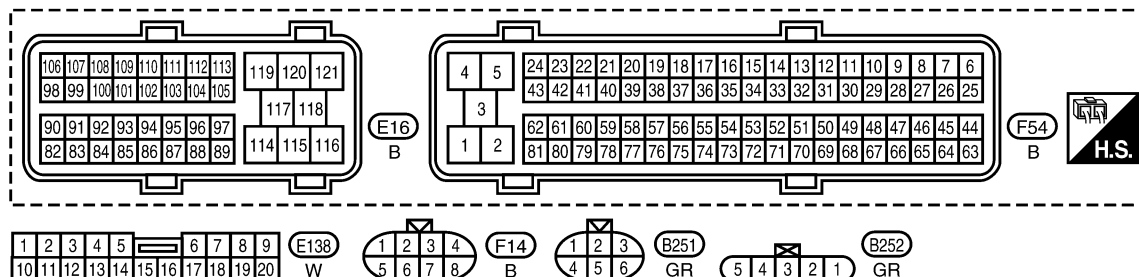
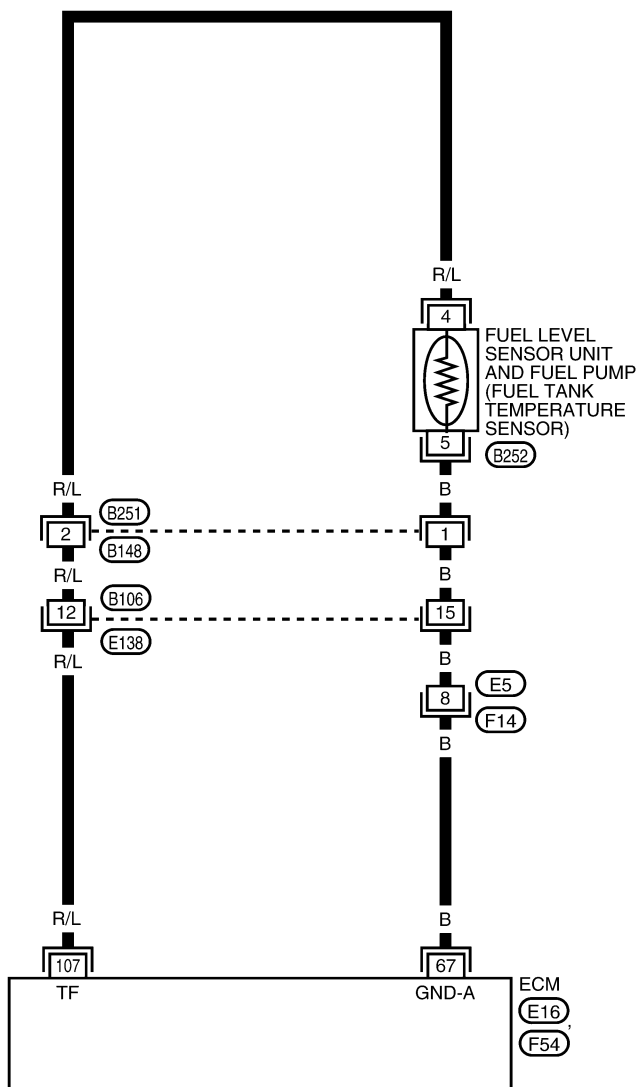

BBWA2516E

DTC P0182, P0183 FTT SENSOR

UBS00P6X

Diagnostic Procedure

1. CHECK GROUND CONNECTIONS

1. Turn ignition switch OFF.
2. Loosen and retighten three ground screws on the body. Refer to [EC-158, "Ground Inspection"](#).

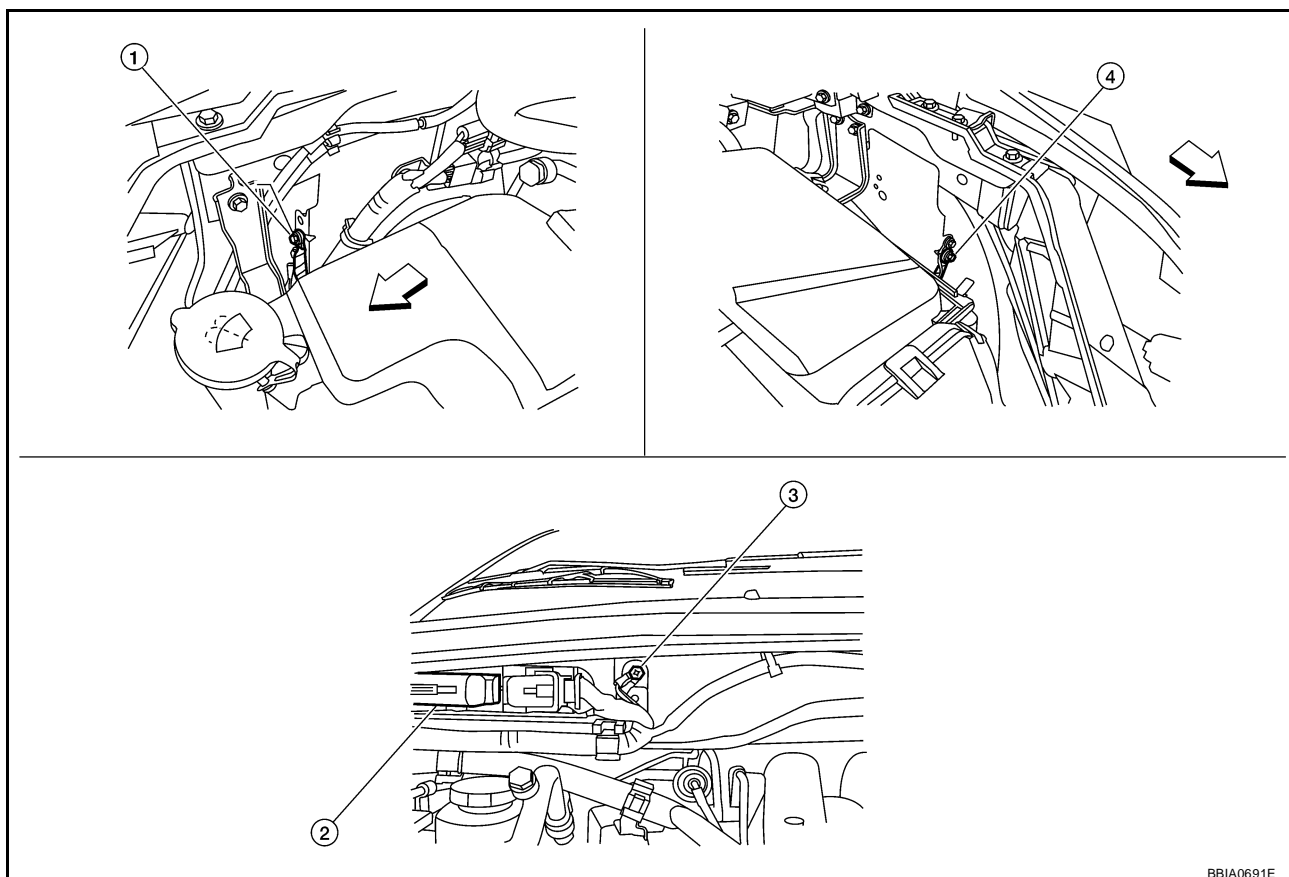

BBIA0691E

← Vehicle front

1. Body ground E24

2. ECM

3. Body ground E9

4. Body ground E15

OK or NG

OK >> GO TO 2.

NG >> Repair or replace ground connections.

DTC P0182, P0183 FTT SENSOR

2. CHECK FUEL TANK TEMPERATURE SENSOR POWER SUPPLY CIRCUIT

1. Disconnect “fuel level sensor unit and fuel pump” harness connector (1).
 - ⇐: Vehicle front
2. Turn ignition switch ON.

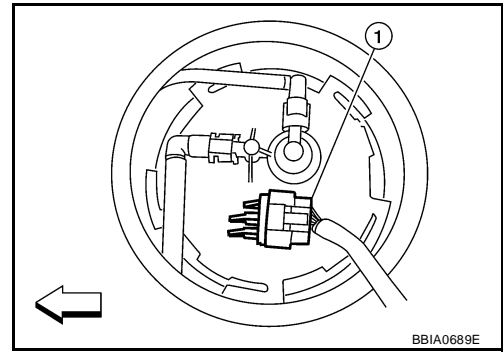

3. Check voltage between “fuel level sensor unit and fuel pump” terminal 4 and ground with CONSULT-II or tester.

Voltage: Approximately 5V

OK or NG

- OK >> GO TO 4.
- NG >> GO TO 3.

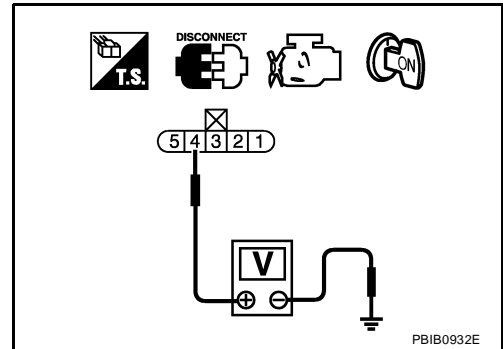

3. DETECT MALFUNCTIONING PART

Check the following.

- Harness connectors B106, E138
- Harness connectors B148, B251
- Harness for open or short between ECM and “fuel level sensor unit and fuel pump”

>> Repair harness or connector.

4. CHECK FUEL TANK TEMPERATURE SENSOR GROUND CIRCUIT FOR OPEN AND SHORT

1. Turn ignition switch OFF.
2. Disconnect ECM harness connector.
3. Check harness continuity between “fuel level sensor unit and fuel pump” terminal 5 and ECM terminal 67. Refer to Wiring Diagram.

Continuity should exist.

4. Also check harness for short to ground and short to power.

OK or NG

- OK >> GO TO 6.
- NG >> GO TO 5.

DTC P0182, P0183 FTT SENSOR

5. DETECT MALFUNCTIONING PART

Check the following.

- Harness connectors E5, F14
- Harness connectors B106, E138
- Harness connectors B148, B251
- Harness for open or short between “fuel level sensor unit and fuel pump” and ECM

>> Repair open circuit or short to ground or short to power in harness or connector.

6. CHECK FUEL TANK TEMPERATURE SENSOR

Refer to [EC-356, "Component Inspection"](#) .

OK or NG

OK >> GO TO 7.

NG >> Replace “fuel level sensor unit and fuel pump”.

7. CHECK INTERMITTENT INCIDENT

Refer to [EC-149, "TROUBLE DIAGNOSIS FOR INTERMITTENT INCIDENT"](#) .

>> INSPECTION END

Component Inspection FUEL TANK TEMPERATURE SENSOR

UBS00P6Y

1. Remove “fuel level sensor unit and fuel pump”.
2. Check resistance between “fuel level sensor unit and fuel pump” terminals 4 and 5 by heating with hot water or heat gun as shown in the figure.

Temperature °C (°F)	Resistance kΩ
20 (68)	2.3 - 2.7
50 (122)	0.79 - 0.90

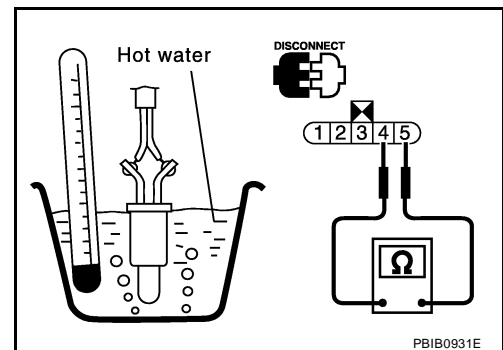

UBS00P6Z

Removal and Installation FUEL TANK TEMPERATURE SENSOR

Refer to [FL-5, "FUEL LEVEL SENSOR UNIT, FUEL FILTER AND FUEL PUMP ASSEMBLY"](#) .

DTC P0222, P0223 TP SENSOR

DTC P0222, P0223 TP SENSOR

PF1:16119

Component Description

UBS00P70

Electric throttle control actuator consists of throttle control motor, throttle position sensor, etc. The throttle position sensor responds to the throttle valve movement.

The throttle position sensor has the two sensors. These sensors are a kind of potentiometers which transform the throttle valve position into output voltage, and emit the voltage signal to the ECM. In addition, these sensors detect the opening and closing speed of the throttle valve and feed the voltage signals to the ECM. The ECM judges the current opening angle of the throttle valve from these signals and the ECM controls the throttle control motor to make the throttle valve opening angle properly in response to driving condition.

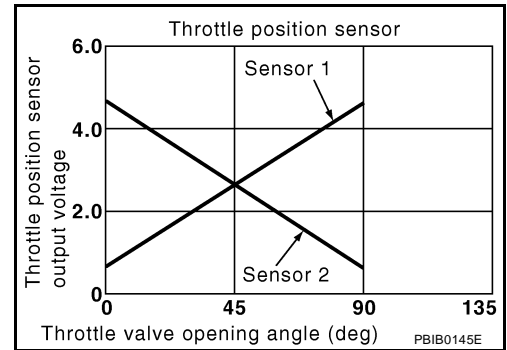

CONSULT-II Reference Value in Data Monitor Mode

UBS00P71

Specification data are reference values.

MONITOR ITEM	CONDITION	SPECIFICATION
THRTL SEN 1 THRTL SEN 2*	● Ignition switch: ON (Engine stopped)	Accelerator pedal: Fully released More than 0.36V
	● Shift lever: D	Accelerator pedal: Fully depressed Less than 4.75V

*: Throttle position sensor 2 signal is converted by ECM internally. Thus, it differs from ECM terminal voltage signal.

On Board Diagnosis Logic

UBS00P72

These self-diagnoses have the one trip detection logic.

DTC No.	Trouble diagnosis name	DTC detecting condition	Possible cause
P0222 0222	Throttle position sensor 1 circuit low input	An excessively low voltage from the TP sensor 1 is sent to ECM.	<ul style="list-style-type: none"> ● Harness or connectors (TP sensor 1 circuit is open or shorted.) (APP sensor 2 circuit is shorted.) ● Electric throttle control actuator (TP sensor 1) ● Accelerator pedal position sensor (APP sensor 2)
P0223 0223	Throttle position sensor 1 circuit high input	An excessively high voltage from the TP sensor 1 is sent to ECM.	

FAIL-SAFE MODE

When the malfunction is detected, ECM enters fail-safe mode and the MIL lights up.

Engine operation condition in fail-safe mode

The ECM controls the electric throttle control actuator in regulating the throttle opening in order for the idle position to be within +10 degrees.

The ECM regulates the opening speed of the throttle valve to be slower than the normal condition.

So, the acceleration will be poor.

DTC P0222, P0223 TP SENSOR

UBS00P73

DTC Confirmation Procedure

NOTE:

If DTC Confirmation Procedure has been previously conducted, always turn ignition switch OFF and wait at least 10 seconds before conducting the next test.

TESTING CONDITION:

Before performing the following procedure, confirm that battery voltage is more than 10V at idle.

WITH CONSULT-II

1. Turn ignition switch ON.
2. Select DATA MONITOR mode with CONSULT-II.
3. Start engine and let it idle for 1 second.
4. If DTC is detected, go to [EC-361, "Diagnostic Procedure"](#) .

DATA MONITOR	
MONITOR	NO DTC
ENG SPEED	XXX rpm

SEF058Y

WITH GST

Follow the procedure "WITH CONSULT-II" above.

DTC P0222, P0223 TP SENSOR

Wiring Diagram

UBS00P74

EC-TPS1-01

: DETECTABLE LINE FOR DTC
 : NON-DETECTABLE LINE FOR DTC

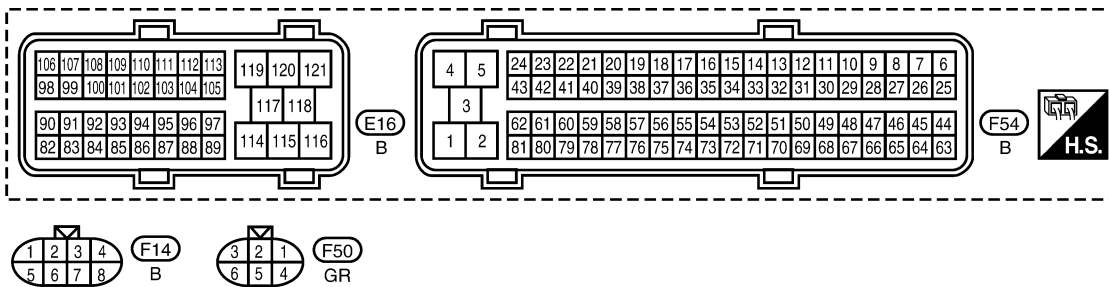
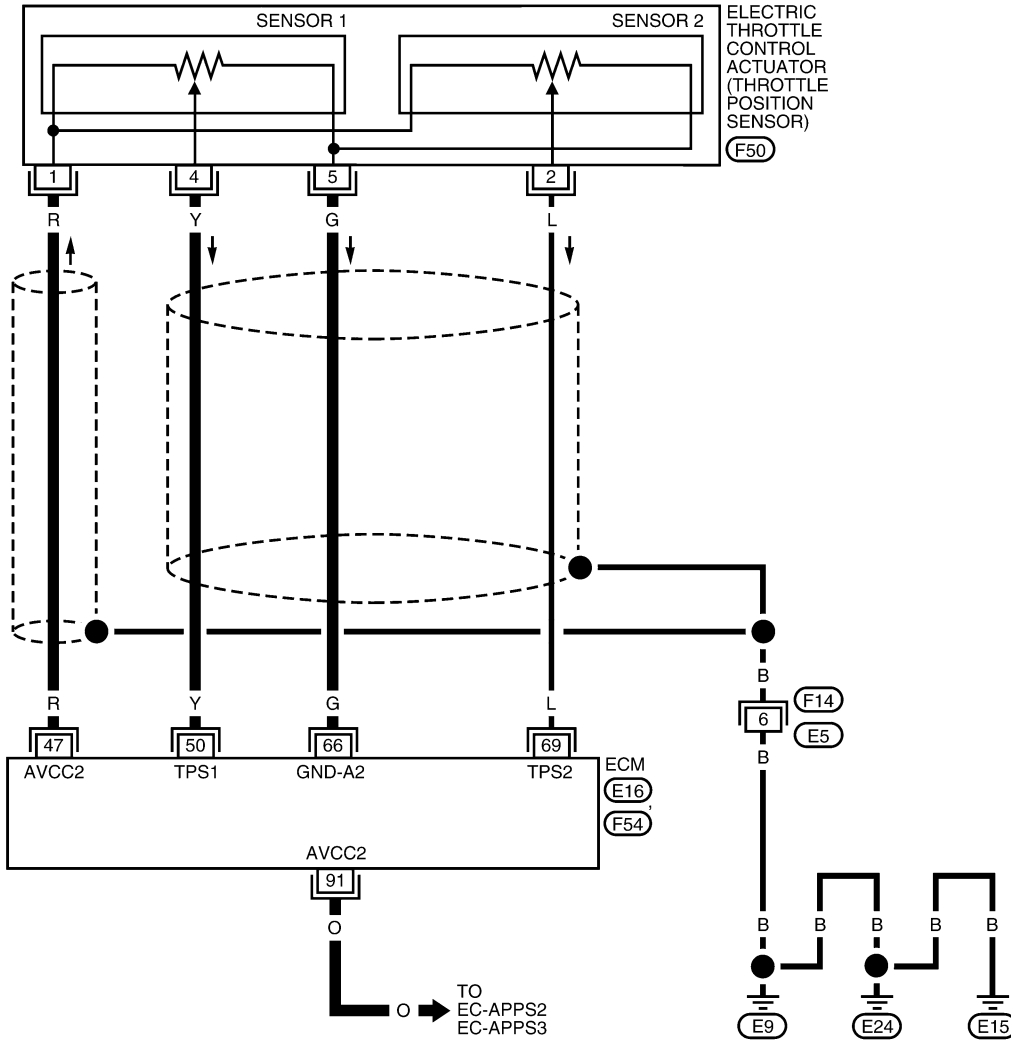

BBWA1610E

DTC P0222, P0223 TP SENSOR

Specification data are reference values and are measured between each terminal and ground.

CAUTION:

Do not use ECM ground terminals when measuring input/output voltage. Doing so may result in damage to the ECM's transistor. Use a ground other than ECM terminals, such as the ground.

TER-MINAL NO.	WIRE COLOR	ITEM	CONDITION	DATA (DC Voltage)
47	R	Throttle position sensor power supply	[Ignition switch: ON]	Approximately 5V
50	Y	Throttle position sensor 1	[Ignition switch: ON] <ul style="list-style-type: none"> ● Engine stopped ● Shift lever: D ● Accelerator pedal: Fully released 	More than 0.36V
			[Ignition switch: ON] <ul style="list-style-type: none"> ● Engine stopped ● Shift lever: D ● Accelerator pedal: Fully depressed 	Less than 4.75V
66	G	Throttle position sensor ground	[Engine is running] <ul style="list-style-type: none"> ● Warm-up condition ● Idle speed 	Approximately 0V
69	L	Throttle position sensor 2	[Ignition switch: ON] <ul style="list-style-type: none"> ● Engine stopped ● Shift lever: D ● Accelerator pedal: Fully released 	Less than 4.75V
			[Ignition switch: ON] <ul style="list-style-type: none"> ● Engine stopped ● Shift lever: D ● Accelerator pedal: Fully depressed 	More than 0.36V
91	O	APP sensor 2 power supply	[Ignition switch: ON]	Approximately 5V

DTC P0222, P0223 TP SENSOR

UBS00P75

Diagnostic Procedure

1. CHECK GROUND CONNECTIONS

1. Turn ignition switch OFF.
2. Loosen and retighten three ground screws on the body. Refer to [EC-158, "Ground Inspection"](#).

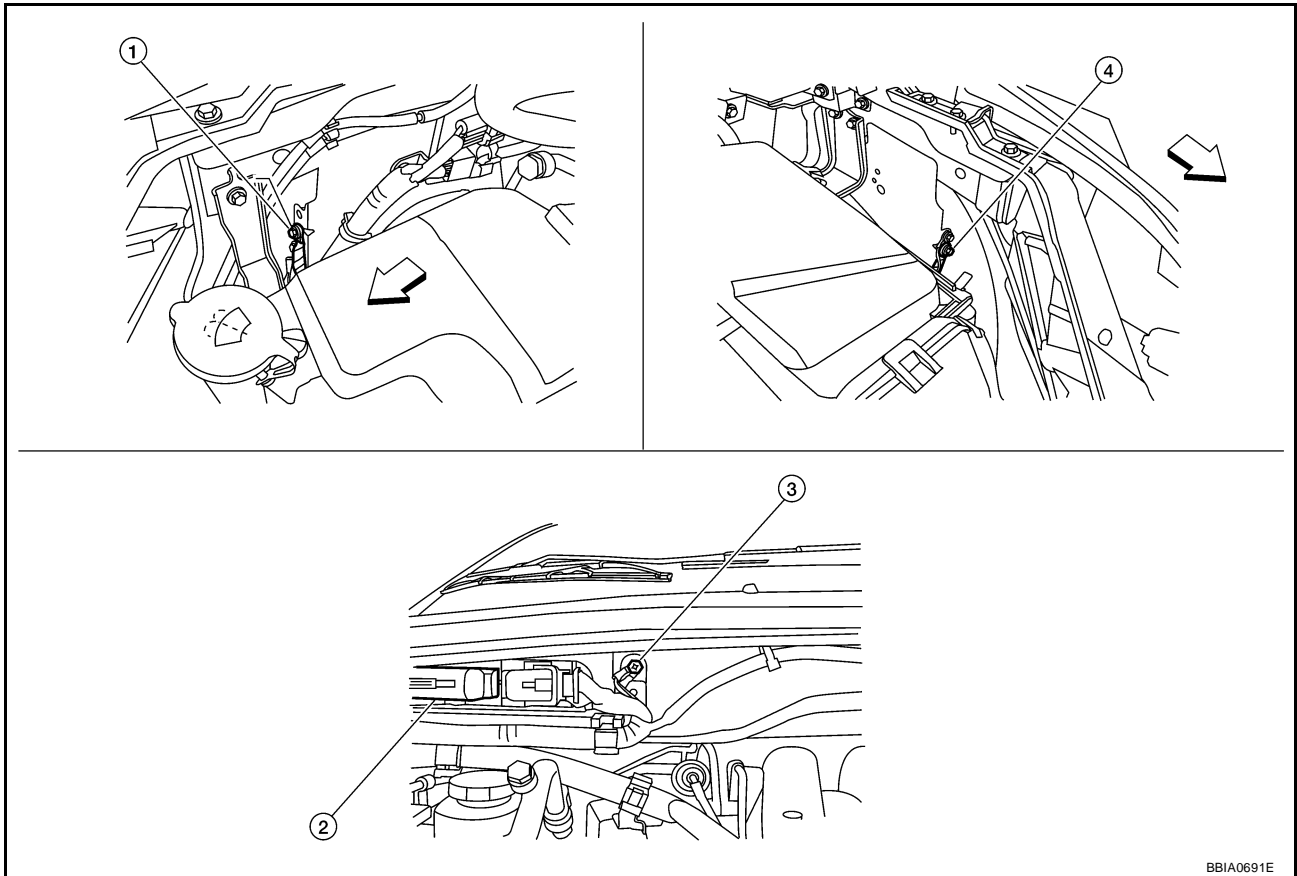

↔ Vehicle front

1. Body ground E24

2. ECM

3. Body ground E9

4. Body ground E15

OK or NG

OK >> GO TO 2.

NG >> Repair or replace ground connections.

DTC P0222, P0223 TP SENSOR

2. CHECK THROTTLE POSITION SENSOR 1 POWER SUPPLY CIRCUIT-I

1. Disconnect electric throttle control actuator harness connector.
2. Turn ignition switch ON.

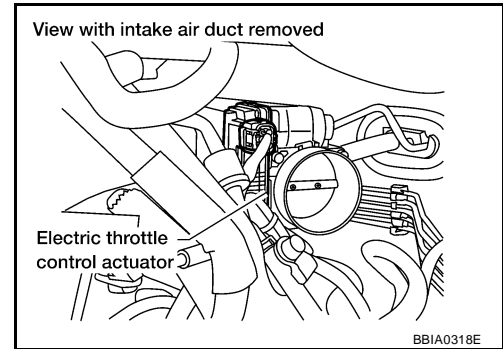

3. Check voltage between electric throttle control actuator terminal 1 and ground with CONSULT-II or tester.

Voltage: Approximately 5V

OK or NG

- OK >> GO TO 7.
NG >> GO TO 3.

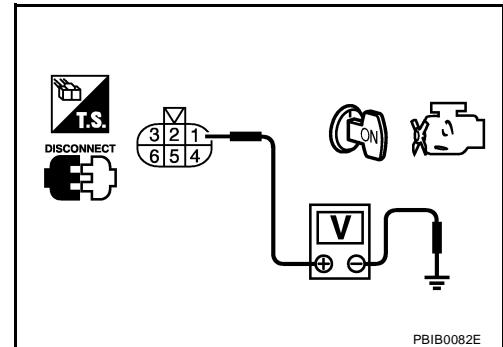

3. CHECK THROTTLE POSITION SENSOR 1 POWER SUPPLY CIRCUIT-II

1. Turn ignition switch OFF.
2. Disconnect ECM harness connector.
3. Check harness continuity between electric throttle control actuator terminal 1 and ECM terminal 47. Refer to Wiring Diagram.

Continuity should exist.

OK or NG

- OK >> GO TO 4.
NG >> Repair open circuit.

4. CHECK THROTTLE POSITION SENSOR 1 POWER SUPPLY CIRCUIT-III

Check harness for short to power and short to ground, between the following terminals.

ECM terminal	Sensor terminal	Reference Wiring Diagram
47	Electric throttle control actuator terminal 1	EC-359
91	APP sensor terminal 6	EC-626

OK or NG

- OK >> GO TO 5.
NG >> Repair short to ground or short to power in harness or connectors.

5. CHECK APP SENSOR

Refer to [EC-631, "Component Inspection"](#).

OK or NG

- OK >> GO TO 11.
NG >> GO TO 6.

DTC P0222, P0223 TP SENSOR

6. REPLACE ACCELERATOR PEDAL ASSEMBLY

1. Replace accelerator pedal assembly.
2. Perform [EC-80, "Accelerator Pedal Released Position Learning"](#) .
3. Perform [EC-80, "Throttle Valve Closed Position Learning"](#) .
4. Perform [EC-80, "Idle Air Volume Learning"](#) .

>> INSPECTION END

7. CHECK THROTTLE POSITION SENSOR 1 GROUND CIRCUIT FOR OPEN AND SHORT

1. Turn ignition switch OFF.
2. Disconnect ECM harness connector.
3. Check harness continuity between ECM terminal 66 and electric throttle control actuator terminal 5. Refer to Wiring Diagram.

Continuity should exist.

4. Also check harness for short to ground and short to power.

OK or NG

OK >> GO TO 8.

NG >> Repair open circuit or short to ground or short to power in harness or connectors.

8. CHECK THROTTLE POSITION SENSOR 1 INPUT SIGNAL CIRCUIT FOR OPEN AND SHORT

1. Check harness continuity between ECM terminal 50 and electric throttle control actuator terminal 4. Refer to Wiring Diagram.

Continuity should exist.

2. Also check harness for short to ground and short to power.

OK or NG

OK >> GO TO 9.

NG >> Repair open circuit or short to ground or short to power in harness or connectors.

9. CHECK THROTTLE POSITION SENSOR

Refer to [EC-364, "Component Inspection"](#) .

OK or NG

OK >> GO TO 11.

NG >> GO TO 10.

10. REPLACE ELECTRIC THROTTLE CONTROL ACTUATOR

1. Replace the electric throttle control actuator.
2. Perform [EC-80, "Throttle Valve Closed Position Learning"](#) .
3. Perform [EC-80, "Idle Air Volume Learning"](#) .

>> INSPECTION END

11. CHECK INTERMITTENT INCIDENT

Refer to [EC-149, "TROUBLE DIAGNOSIS FOR INTERMITTENT INCIDENT"](#) .

>> INSPECTION END

DTC P0222, P0223 TP SENSOR

UBS00P76

Component Inspection THROTTLE POSITION SENSOR

1. Reconnect all harness connectors disconnected.
2. Perform [EC-80, "Throttle Valve Closed Position Learning"](#) .
3. Turn ignition switch ON.
4. Set shift lever to D position.
5. Check voltage between ECM terminals 50 (TP sensor 1 signal), 69 (TP sensor 2 signal) and ground under the following conditions.

Terminal	Accelerator pedal	Voltage
50 (Throttle position sensor 1)	Fully released	More than 0.36V
	Fully depressed	Less than 4.75V
69 (Throttle position sensor 2)	Fully released	Less than 4.75V
	Fully depressed	More than 0.36V

6. If NG, replace electric throttle control actuator and go to the next step.
7. Perform [EC-80, "Throttle Valve Closed Position Learning"](#) .
8. Perform [EC-80, "Idle Air Volume Learning"](#) .

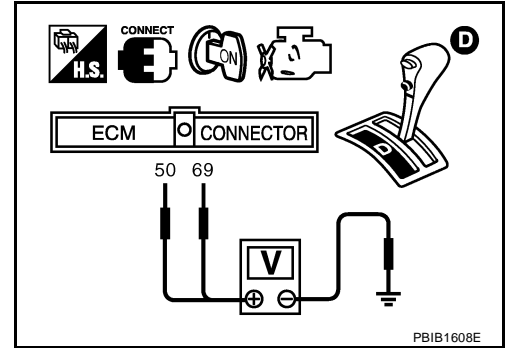

PBIB1608E

Removal and Installation ELECTRIC THROTTLE CONTROL ACTUATOR

UBS00P77

Refer to [EM-18, "INTAKE MANIFOLD COLLECTOR"](#) .

DTC P0300 - P0306 MULTIPLE CYLINDER MISFIRE, NO. 1 - 6 CYLINDER MISFIRE

DTC P0300 - P0306 MULTIPLE CYLINDER MISFIRE, NO. 1 - 6 CYLINDER MISFIRE

PF0:0000

On Board Diagnosis Logic

UBS00P78

When a misfire occurs, engine speed will fluctuate. If the engine speed fluctuates enough to cause the crankshaft position (CKP) sensor (POS) signal to vary, ECM can determine that a misfire is occurring.

Sensor	Input Signal to ECM	ECM function
Crankshaft position sensor (POS)	Engine speed	On board diagnosis of misfire

The misfire detection logic consists of the following two conditions.

- One Trip Detection Logic (Three Way Catalyst Damage)**
 On the first trip that a misfire condition occurs that can damage the three way catalyst (TWC) due to overheating, the MIL will blink.
 When a misfire condition occurs, the ECM monitors the CKP sensor signal every 200 engine revolutions for a change.
 When the misfire condition decreases to a level that will not damage the TWC, the MIL will turn off.
 If another misfire condition occurs that can damage the TWC on a second trip, the MIL will blink.
 When the misfire condition decreases to a level that will not damage the TWC, the MIL will remain on.
 If another misfire condition occurs that can damage the TWC, the MIL will begin to blink again.
- Two Trip Detection Logic (Exhaust quality deterioration)**
 For misfire conditions that will not damage the TWC (but will affect vehicle emissions), the MIL will only light when the misfire is detected on a second trip. During this condition, the ECM monitors the CKP sensor signal every 1,000 engine revolutions.
 A misfire malfunction can be detected on any one cylinder or on multiple cylinders.

DTC No.	Trouble diagnosis name	DTC detecting condition	Possible cause
P0300 0300	Multiple cylinder misfire detected	Multiple cylinder misfire.	<ul style="list-style-type: none"> ● Improper spark plug ● Insufficient compression ● Incorrect fuel pressure ● The fuel injector circuit is open or shorted ● Fuel injector ● Intake air leak ● The ignition signal circuit is open or shorted ● Lack of fuel ● Signal plate ● Air fuel ratio (A/F) sensor 1 ● Incorrect PCV hose connection
P0301 0301	No.1 cylinder misfire detected	No. 1 cylinder misfires.	
P0302 0302	No. 2 cylinder misfire detected	No. 2 cylinder misfires.	
P0303 0303	No. 3 cylinder misfire detected	No. 3 cylinder misfires.	
P0304 0304	No. 4 cylinder misfire detected	No. 4 cylinder misfires.	
P0305 0305	No. 5 cylinder misfire detected	No. 5 cylinder misfires.	
P0306 0306	No. 6 cylinder misfire detected	No. 6 cylinder misfires.	

DTC Confirmation Procedure

UBS00P79

CAUTION:

Always drive vehicle in safe manner according to traffic conditions and obey all traffic laws when driving.

NOTE:

If DTC Confirmation Procedure has been previously conducted, always turn ignition switch OFF and wait at least 10 seconds before conducting the next test.

DTC P0300 - P0306 MULTIPLE CYLINDER MISFIRE, NO. 1 - 6 CYLINDER MISFIRE

⑧ WITH CONSULT-II

1. Turn ignition switch ON, and select "DATA MONITOR" mode with CONSULT-II.
2. Start engine and warm it up to normal operating temperature.
3. Turn ignition switch OFF and wait at least 10 seconds.
4. Restart engine and let it idle for about 15 minutes.
5. If 1st trip DTC is detected, go to [EC-366, "Diagnostic Procedure"](#).

DATA MONITOR	
MONITOR	NO DTC
ENG SPEED	XXX rpm
COOLAN TEMP/S	XXX °C
VHCL SPEED SE	XXX km/h
B/FUEL SCHDL	XXX msec

PBIB0164E

NOTE:

If 1st trip DTC is not detected during above procedure, performing the following procedure is advised.

- a. Turn ignition switch OFF and wait at least 10 seconds.
- b. Start engine and drive the vehicle under the similar conditions to (1st trip) Freeze Frame Data for a certain time. Refer to the table below.

Hold the accelerator pedal as steady as possible.

The similar conditions to (1st trip) Freeze Frame Data means the vehicle operation that the following conditions should be satisfied at the same time.

Engine speed	Engine speed in the freeze frame data ± 400 rpm
Vehicle speed	Vehicle speed in the freeze frame data ± 10 km/h (6 MPH)
Engine coolant temperature (T) condition	When the freeze frame data shows lower than 70 °C (158 °F), T should be lower than 70 °C (158 °F).
	When the freeze frame data shows higher than or equal to 70 °C (158 °F), T should be higher than or equal to 70 °C (158 °F).

The time to driving varies according to the engine speed in the freeze frame data.

Engine speed	Time
Around 1,000 rpm	Approximately 10 minutes
Around 2,000 rpm	Approximately 5 minutes
More than 3,000 rpm	Approximately 3.5 minutes

⑧ WITH GST

Follow the procedure "WITH CONSULT-II" above.

Diagnostic Procedure

UBS00P7A

1. CHECK FOR INTAKE AIR LEAK AND PCV HOSE

1. Start engine and run it at idle speed.
2. Listen for the sound of the intake air leak.
3. Check PCV hose connection.

OK or NG

- OK >> GO TO 2.
 NG >> Discover air leak location and repair.

2. CHECK FOR EXHAUST SYSTEM CLOGGING

Stop engine and visually check exhaust tube, three way catalyst and muffler for dents.

OK or NG

- OK (With CONSULT-II) >> GO TO 3.
 OK (Without CONSULT-II) >> GO TO 4.
 NG >> Repair or replace it.

DTC P0300 - P0306 MULTIPLE CYLINDER MISFIRE, NO. 1 - 6 CYLINDER MISFIRE

3. PERFORM POWER BALANCE TEST

With CONSULT-II

1. Perform "POWER BALANCE" in "ACTIVE TEST" mode.
2. Is there any cylinder which does not produce a momentary engine speed drop?

ACTIVE TEST	
POWER BALANCE	
MONITOR	
ENG SPEED	XXX rpm
MAS A/F SE-B1	XXX V

PBIB0133E

Yes or No

- Yes >> GO TO 4.
 No >> GO TO 11.

4. CHECK FUNCTION OF FUEL INJECTOR-I

1. Stop engine.
2. Disconnect harness connector F44 (2), F101 (3).
3. Turn ignition switch ON.
 - ⇐: Vehicle front
 - Intake manifold collector (1)

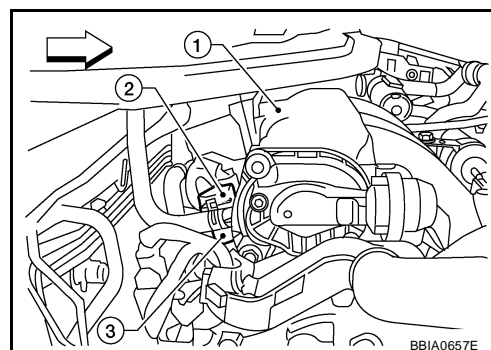

4. Check voltage between harness connector F44 terminal 5 and ground with CONSULT-II or tester.

Voltage: Battery voltage

5. Turn ignition switch OFF.
6. Disconnect ECM harness connector.
7. Check harness continuity between harness connector F44 terminal and ECM terminal as follows. Refer to Wiring Diagram.

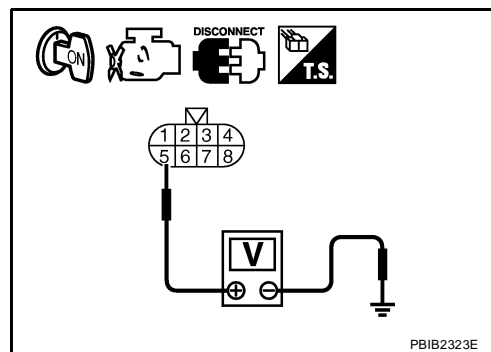

Cylinder	Harness connector F44 terminal	ECM terminal
1	6	23
3	2	22
5	1	21

Continuity should exist.

8. Also check harness for short to ground and short to power.

OK or NG

- OK >> GO TO 5.
 NG >> Perform trouble diagnosis for FUEL INJECTOR, refer to [EC-678. "FUEL INJECTOR"](#).

DTC P0300 - P0306 MULTIPLE CYLINDER MISFIRE, NO. 1 - 6 CYLINDER MISFIRE

5. CHECK FUNCTION OF FUEL INJECTOR-II

Provide battery voltage between harness connector F101 as follows and then interrupt it. Listen to each fuel injector operating sound.

Cylinder	Harness connector F101 terminal	
	(+)	(-)
1	5	6
3	5	2
5	5	1

Operating sound should exist.

OK or NG

OK >> GO TO 6.

NG >> Perform trouble diagnosis for FUEL INJECTOR, refer to [EC-678, "FUEL INJECTOR"](#).

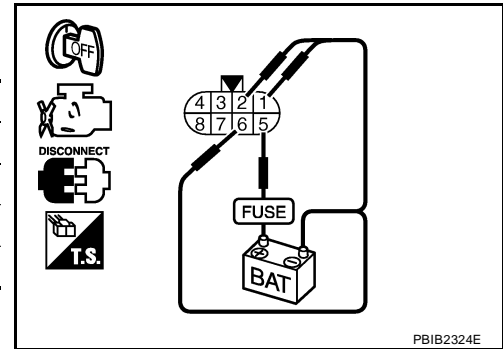

6. CHECK FUNCTION OF FUEL INJECTOR-III

1. Reconnect all harness connector disconnected.
2. Start engine.
3. Listen to fuel injectors No. 2, No. 4, No.6 operating sound.

Clicking noise should exist.

OK or NG

OK >> GO TO 7.

NG >> Perform trouble diagnosis for FUEL INJECTOR, refer to [EC-678, "FUEL INJECTOR"](#).

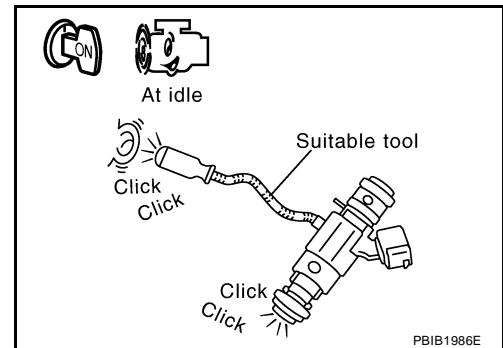

DTC P0300 - P0306 MULTIPLE CYLINDER MISFIRE, NO. 1 - 6 CYLINDER MISFIRE

7. CHECK FUNCTION OF IGNITION COIL-I

CAUTION:

Do the following procedure in the place where ventilation is good without the combustible.

1. Turn ignition switch OFF.
2. Remove fuel pump fuse in IPDM E/R to release fuel pressure.

NOTE:

Do not use CONSULT-II to release fuel pressure, or fuel pressure applies again during the following procedure.

3. Start engine.
4. After engine stalls, crank it two or three times to release all fuel pressure.
5. Turn ignition switch OFF.
6. Remove all ignition coil harness connectors to avoid the electrical discharge from the ignition coils.
7. Remove ignition coil and spark plug of the cylinder to be checked.
8. Crank engine for 5 seconds or more to remove combustion gas in the cylinder.
9. Connect spark plug and harness connector to ignition coil.
10. Fix ignition coil using a rope etc. with gap of 13 - 17 mm between the edge of the spark plug and grounded metal portion as shown in the figure.
11. Crank engine for about 3 seconds, and check whether spark is generated between the spark plug and the grounded metal portion.

Spark should be generated.

CAUTION:

- Do not approach to the spark plug and the ignition coil within 50cm. Be careful not to get an electrical shock while checking, because the electrical discharge voltage becomes 20kV or more.

- It might cause to damage the ignition coil if the gap of more than 17 mm is taken.

NOTE:

When the gap is less than 13 mm, the spark might be generated even if the coil is malfunctioning.

OK or NG

- OK >> GO TO 11.
NG >> GO TO 8.

8. CHECK FUNCTION OF IGNITION COIL-II

1. Turn ignition switch OFF.
2. Disconnect spark plug and connect a known-good spark plug.
3. Crank engine for about 3 seconds, and recheck whether spark is generated between the spark plug and the grounded metal portion.

Spark should be generated.

OK or NG

- OK >> GO TO 9.
NG >> Check ignition coil, power transistor and their circuits. Refer to [EC-691, "IGNITION SIGNAL"](#).

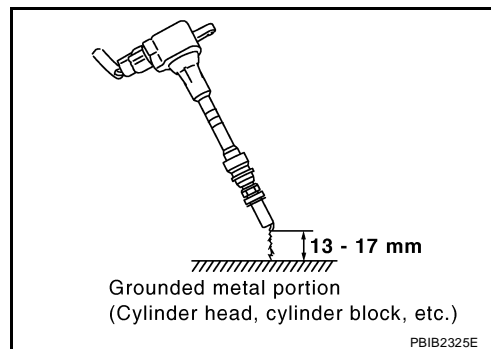
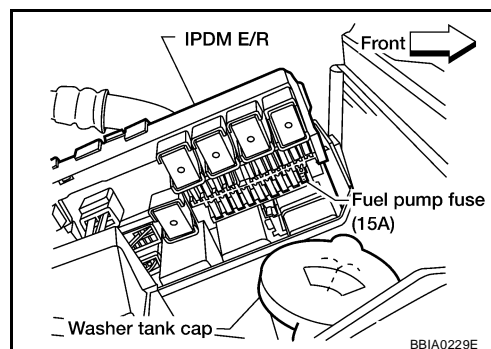

DTC P0300 - P0306 MULTIPLE CYLINDER MISFIRE, NO. 1 - 6 CYLINDER MISFIRE

9. CHECK SPARK PLUG

Check the initial spark plug for fouling, etc.

OK or NG

- OK >> Replace spark plug(s) with standard type one(s). For spark plug type, refer to [MA-20, "Changing Spark Plugs \(Platinum - Tipped Type\)"](#) .
- NG >> 1. Repair or clean spark plug.
2. GO TO 10.

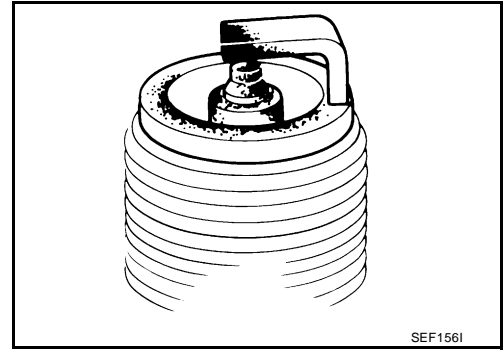

10. CHECK FUNCTION OF IGNITION COIL-III

1. Reconnect the initial spark plugs.
2. Crank engine for about three seconds, and recheck whether spark is generated between the spark plug and the grounded portion.

Spark should be generated.

OK or NG

- OK >> **INSPECTION END**
- NG >> Replace spark plug(s) with standard type one(s). For spark plug type, refer to [MA-20, "Changing Spark Plugs \(Platinum - Tipped Type\)"](#) .

11. CHECK COMPRESSION PRESSURE

Check compression pressure. Refer to [EM-96, "CHECKING COMPRESSION PRESSURE"](#) .

OK or NG

- OK >> GO TO 12.
- NG >> Check pistons, piston rings, valves, valve seats and cylinder head gaskets.

12. CHECK FUEL PRESSURE

1. Install all removed parts.
2. Release fuel pressure to zero. Refer to [EC-82, "FUEL PRESSURE RELEASE"](#) .
3. Install fuel pressure gauge and check fuel pressure. Refer to [EC-83, "FUEL PRESSURE CHECK"](#) .

At idling: Approximately 350 kPa (3.57 kg/cm² , 51 psi)

OK or NG

- OK >> GO TO 14.
- NG >> GO TO 13.

13. DETECT MALFUNCTIONING PART

Check the following.

- Fuel pump and circuit (Refer to [EC-685, "FUEL PUMP"](#) .)
- Fuel pressure regulator (Refer to [EC-83, "FUEL PRESSURE CHECK"](#) .)
- Fuel lines
- Fuel filter for clogging

>> Repair or replace.

DTC P0300 - P0306 MULTIPLE CYLINDER MISFIRE, NO. 1 - 6 CYLINDER MISFIRE

14. CHECK IGNITION TIMING

Check the following items. Refer to [EC-73, "Basic Inspection"](#) .

Items	Specifications
Target idle speed	675 ± 50 rpm (in P or N position)
Ignition timing	15 ± 5° BTDC (in P or N position)

OK or NG

OK >> GO TO 15.

NG >> Follow the [EC-73, "Basic Inspection"](#) .

A
EC
C
D
E
F
G
H
I
J
K
L
M

DTC P0300 - P0306 MULTIPLE CYLINDER MISFIRE, NO. 1 - 6 CYLINDER MISFIRE

15. CHECK A/F SENSOR 1 INPUT SIGNAL

1. Turn ignition switch OFF.
2. Disconnect A/F sensor 1 harness connector.

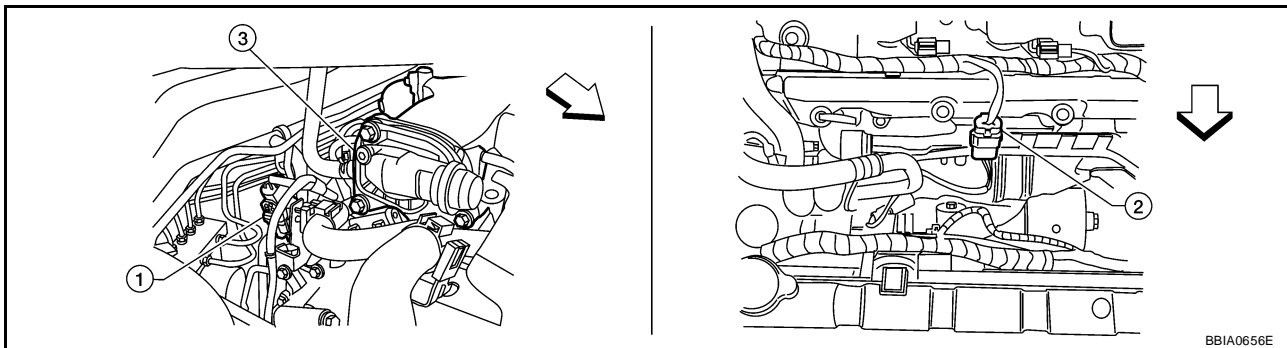

↶: Vehicle front

1. Air fuel ratio (A/F) sensor 1 (bank 1) harness connector
2. Air fuel ratio (A/F) sensor 1 (bank 2) harness connector
3. Intake manifold collector harness connector

3. Disconnect ECM harness connector.
4. Check harness continuity between the following terminals. Refer to Wiring Diagram.

	A/F sensor 1 terminal	ECM terminal
Bank 1	1	16
	2	75
	5	35
	6	56
Bank 2	1	76
	2	77
	5	57
	6	58

Continuity should exist.

5. Check harness continuity between the following terminals and ground. Refer to Wiring Diagram.

Bank 1		Bank 2	
A/F sensor 1 terminal	ECM terminal	A/F sensor 1 terminal	ECM terminal
1	16	1	76
2	75	2	77
5	35	5	57
6	56	6	58

Continuity should not exist.

6. Also check harness for short to power.

OK or NG

OK >> GO TO 16.

NG >> Repair open circuit or short to ground or short to power in harness or connectors.

DTC P0300 - P0306 MULTIPLE CYLINDER MISFIRE, NO. 1 - 6 CYLINDER MISFIRE

16. CHECK A/F SENSOR 1 HEATER

Refer to [EC-175, "Component Inspection"](#) .

OK or NG

OK >> GO TO 17.

NG >> Replace (malfunctioning) A/F sensor 1.

17. CHECK MASS AIR FLOW SENSOR

 **With CONSULT-II**

Check mass air flow sensor signal in "DATA MONITOR" mode with CONSULT-II.

2.0 - 6.0 g-m/sec: at idling

7.0 - 20.0 g-m/sec: at 2,500 rpm

 **With GST**

Check mass air flow sensor signal in Service \$01 with GST.

2.0 - 6.0 g-m/sec: at idling

7.0 - 20.0 g-m/sec: at 2,500 rpm

OK or NG

OK >> GO TO 18.

NG >> Check connectors for rusted terminals or loose connections in the mass air flow sensor circuit or ground. Refer to [EC-192, "DTC P0101 MAF SENSOR"](#) .

18. CHECK SYMPTOM MATRIX CHART

Check items on the rough idle symptom in [EC-95, "Symptom Matrix Chart"](#) .

OK or NG

OK >> GO TO 19.

NG >> Repair or replace.

19. ERASE THE 1ST TRIP DTC

Some tests may cause a 1st trip DTC to be set.

Erase the 1st trip DTC from the ECM memory after performing the tests. Refer to [EC-63, "HOW TO ERASE EMISSION-RELATED DIAGNOSTIC INFORMATION"](#) .

>> GO TO 20.

20. CHECK INTERMITTENT INCIDENT

Refer to [EC-149, "TROUBLE DIAGNOSIS FOR INTERMITTENT INCIDENT"](#) .

>> **INSPECTION END**

DTC P0327, P0328 KS

PF2:22060

DTC P0327, P0328 KS

Component Description

UBS00P7B

The knock sensor is attached to the cylinder block. It senses engine knocking using a piezoelectric element. A knocking vibration from the cylinder block is sensed as vibrational pressure. This pressure is converted into a voltage signal and sent to the ECM.

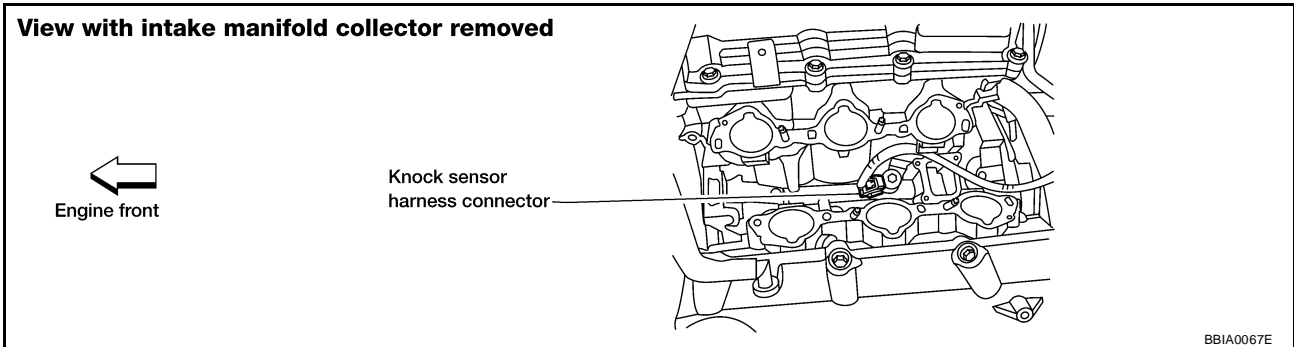

On Board Diagnosis Logic

UBS00P7C

The MIL will not light up for these diagnoses.

DTC No.	Trouble diagnosis name	DTC detected condition	Possible cause
P0327 0327	Knock sensor circuit low input	An excessively low voltage from the sensor is sent to ECM.	<ul style="list-style-type: none"> ● Harness or connectors (The sensor circuit is open or shorted.) ● Knock sensor
P0328 0328	Knock sensor circuit high input	An excessively high voltage from the sensor is sent to ECM.	

DTC Confirmation Procedure

UBS00P7D

NOTE:

If DTC Confirmation Procedure has been previously conducted, always turn ignition switch OFF and wait at least 10 seconds before conducting the next test.

TESTING CONDITION:

Before performing the following procedure, confirm that battery voltage is more than 10V at idle.

WITH CONSULT-II

1. Turn ignition switch ON and select "DATA MONITOR" mode with CONSULT-II.
2. Start engine and run it for at least 5 seconds at idle speed.
3. If 1st trip DTC is detected, go to [EC-376, "Diagnostic Procedure"](#)

WITH GST

Follow the procedure "WITH CONSULT-II" above.

DTC P0327, P0328 KS

Wiring Diagram

UBS00P7E

EC-KS-01

A

EC

C

D

E

F

G

H

I

J

K

L

M

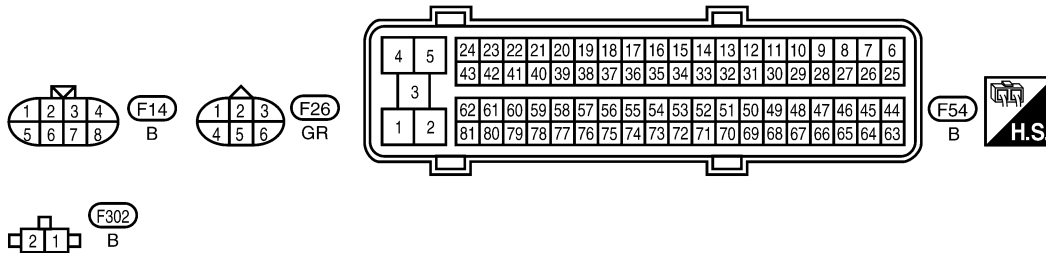
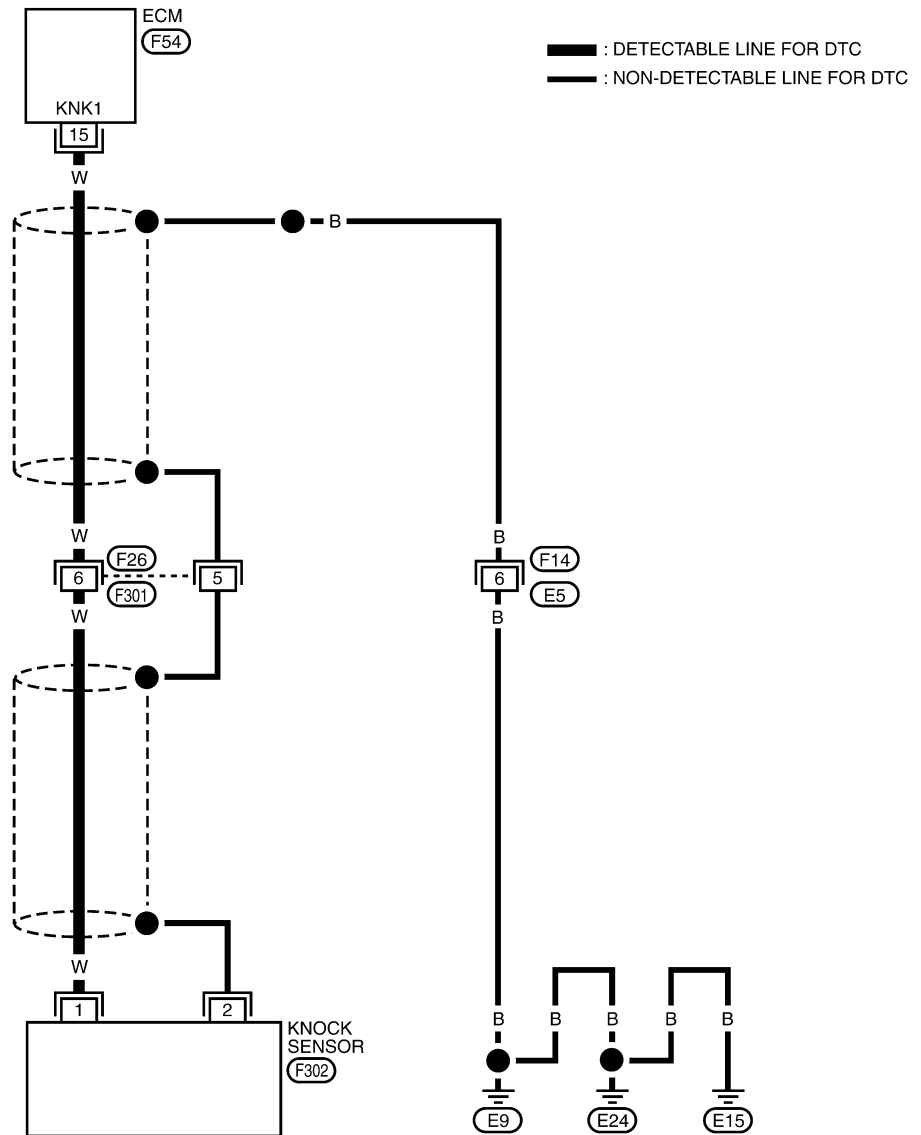

BBWA1611E

DTC P0327, P0328 KS

Specification data are reference values and are measured between each terminal and ground.

CAUTION:

Do not use ECM ground terminals when measuring input/output voltage. Doing so may result in damage to the ECM's transistor. Use a ground other than ECM terminals, such as the ground.

TER-MINAL NO.	WIRE COLOR	ITEM	CONDITION	DATA (DC Voltage)
15	W	Knock sensor	[Engine is running] ● Idle speed	Approximately 2.5V

Diagnostic Procedure

UBS00P7F

1. CHECK KNOCK SENSOR INPUT SIGNAL CIRCUIT FOR OPEN AND SHORT-I

1. Turn ignition switch OFF.
2. Disconnect ECM harness connector.
3. Check resistance between ECM terminal 15 and ground. Refer to Wiring Diagram.

NOTE:

It is necessary to use an ohmmeter which can measure more than 10 M Ω .

Resistance: Approximately 532 - 588 k Ω [at 20°C (68°F)]

4. Also check harness for short to ground and short to power.

OK or NG

- OK >> GO TO 5.
NG >> GO TO 2.

2. CHECK KNOCK SENSOR INPUT SIGNAL CIRCUIT FOR OPEN AND SHORT-II

1. Disconnect knock sensor harness connector.

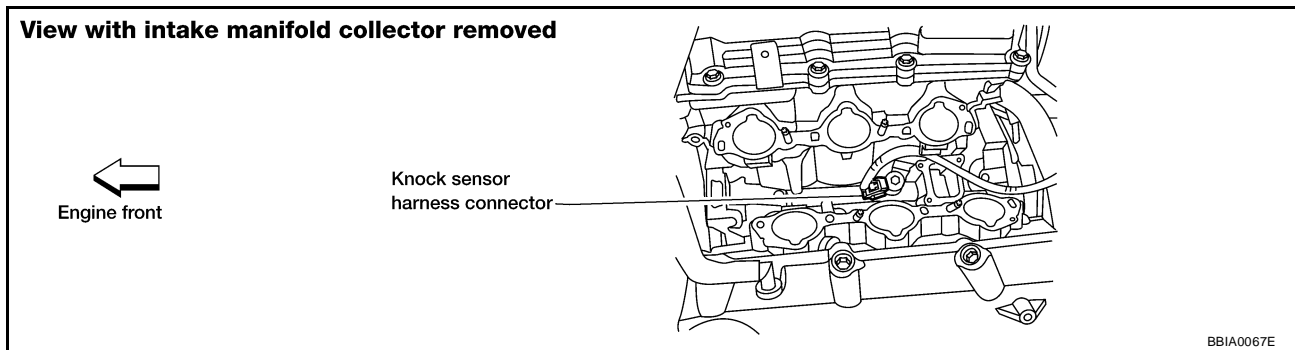

2. Check harness continuity between ECM terminal 15 and knock sensor terminal 1. Refer to Wiring Diagram.

Continuity should exist.

3. Also check harness for short to ground and short to power.

OK or NG

- OK >> GO TO 4.
NG >> GO TO 3.

3. DETECT MALFUNCTIONING PART

Check the following.

- Harness connectors F26, F301
- Harness for open or short between ECM and knock sensor

>> Repair open circuit or short to ground or short to power in harness or connectors.

DTC P0327, P0328 KS

4. CHECK KNOCK SENSOR

Refer to [EC-378, "Component Inspection"](#) .

OK or NG

- OK >> GO TO 5.
- NG >> Replace knock sensor.

5. CHECK GROUND CONNECTIONS

1. Loosen and retighten three ground screws on the body. Refer to [EC-158, "Ground Inspection"](#) .

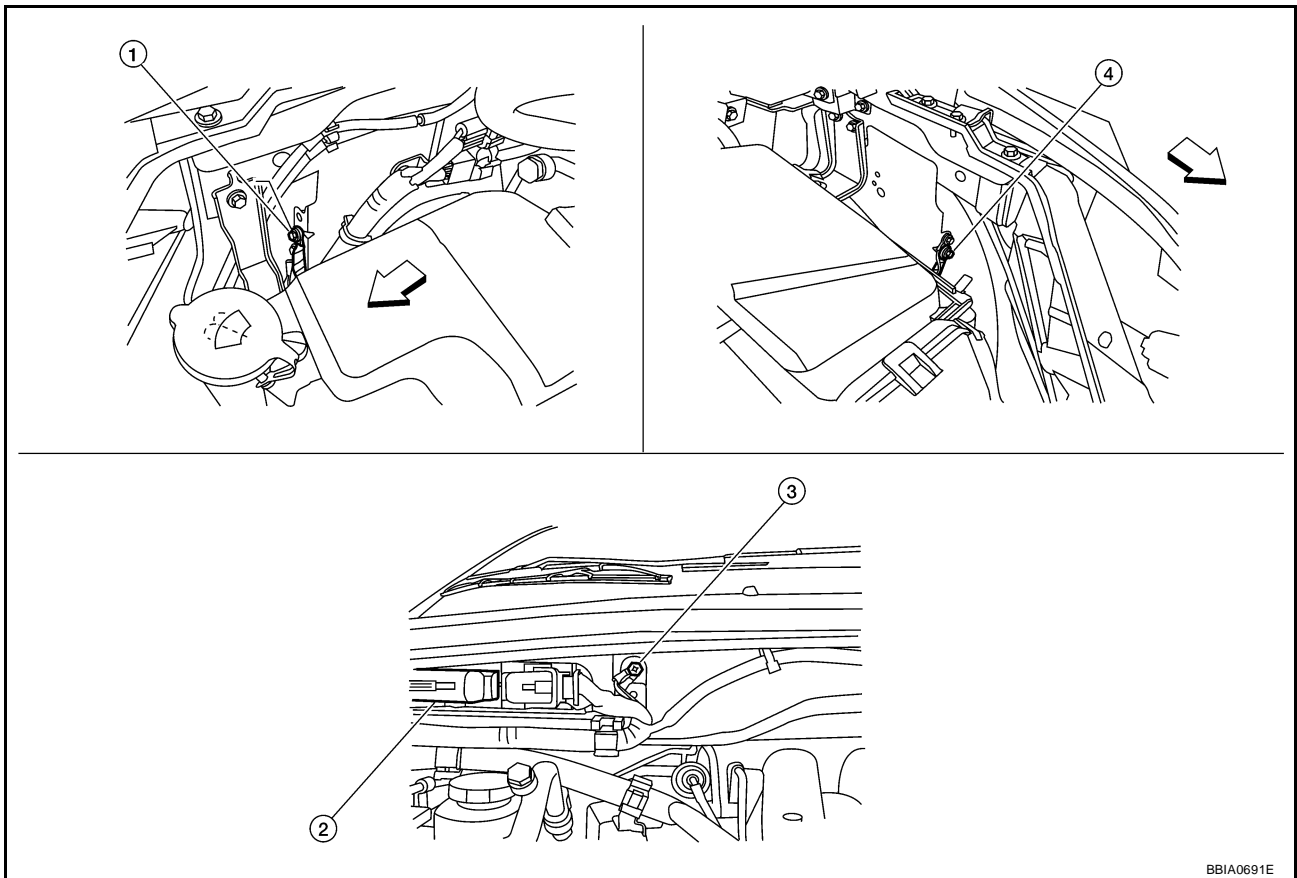

↔ Vehicle front

- 1. Body ground E24
- 2. ECM
- 3. Body ground E9
- 4. Body ground E15

OK or NG

- OK >> GO TO 6.
- NG >> Repair or replace ground connections.

6. CHECK KNOCK SENSOR SHIELD CIRCUIT FOR OPEN AND SHORT

1. Disconnect knock sensor harness connector.
2. Check harness continuity between knock sensor terminal 2 and ground. Refer to Wiring Diagram.

Continuity should exist.

3. Also check harness for short to power.

OK or NG

- OK >> GO TO 8.
- NG >> GO TO 7.

DTC P0327, P0328 KS

7. DETECT MALFUNCTIONING PART

Check the following.

- Harness connectors F26, F301
- Harness connectors E5, F14
- Harness for open or short between knock sensor and ground

>> Repair open circuit or short to power in harness or connectors.

8. CHECK INTERMITTENT INCIDENT

Refer to [EC-149, "TROUBLE DIAGNOSIS FOR INTERMITTENT INCIDENT"](#) .

>> INSPECTION END

Component Inspection KNOCK SENSOR

UBS00P7G

Check resistance between knock sensor terminal 1 and ground.

NOTE:

It is necessary to use an ohmmeter which can measure more than 10 M Ω .

Resistance: Approximately 532 - 588 k Ω [at 20°C (68°F)]

CAUTION:

Do not use any knock sensors that have been dropped or physically damaged. Use only new ones.

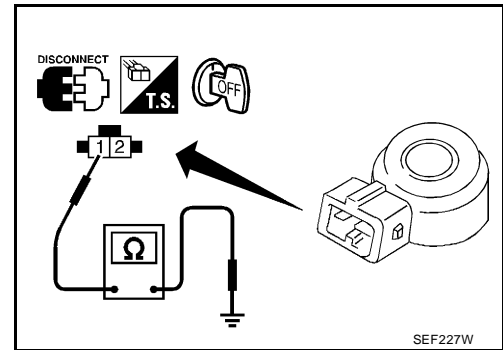

SEF227W

Removal and Installation KNOCK SENSOR

UBS00P7H

Refer to [EM-118, "CYLINDER BLOCK"](#) .

DTC P0335 CKP SENSOR (POS)

PF:23731

DTC P0335 CKP SENSOR (POS)

Component Description

UBS00P7I

The crankshaft position sensor (POS) is located on the oil pan facing the gear teeth (cogs) of the signal plate. It detects the fluctuation of the engine revolution.

The sensor consists of a permanent magnet and Hall IC.

When the engine is running, the high and low parts of the teeth cause the gap with the sensor to change.

The changing gap causes the magnetic field near the sensor to change.

Due to the changing magnetic field, the voltage from the sensor changes.

The ECM receives the voltage signal and detects the fluctuation of the engine revolution.

ECM receives the signals as shown in the figure.

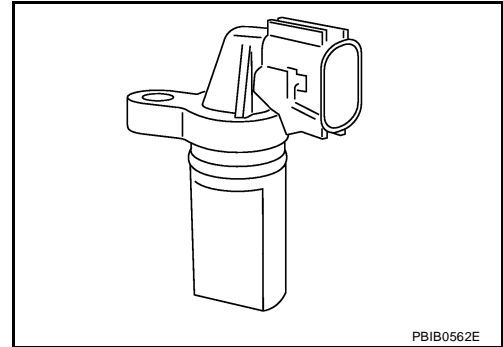

PBIB0562E

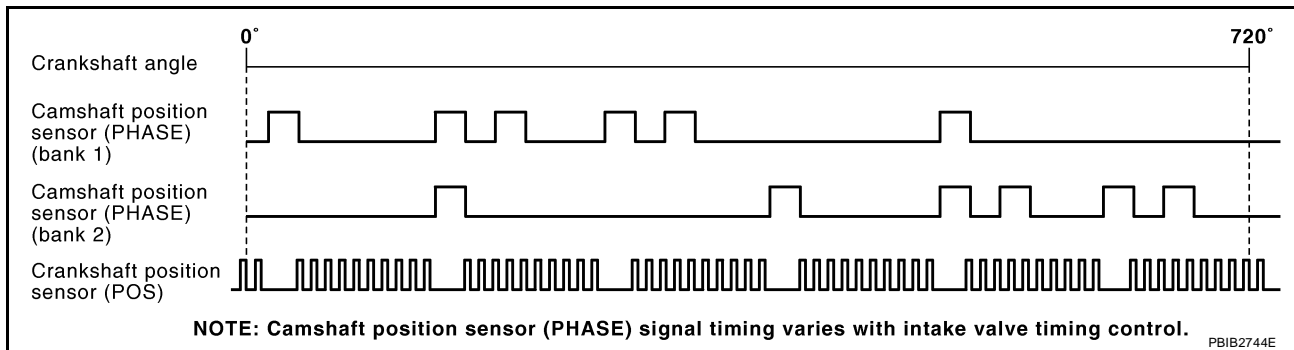

PBIB2744E

CONSULT-II Reference Value in Data Monitor Mode

UBS00P7J

Specification data are reference values.

MONITOR ITEM	CONDITION	SPECIFICATION
ENG SPEED	● Run engine and compare CONSULT-II value with the tachometer indication.	Almost the same speed as the tachometer indication

On Board Diagnosis Logic

UBS00P7K

DTC No.	Trouble diagnosis name	DTC detecting condition	Possible cause
P0335 0335	Crankshaft position sensor (POS) circuit	<ul style="list-style-type: none"> ● The crankshaft position sensor (POS) signal is not detected by the ECM during the first few seconds of engine cranking. ● The proper pulse signal from the crankshaft position sensor (POS) is not sent to ECM while the engine is running. ● The crankshaft position sensor (POS) signal is not in the normal pattern during engine running. 	<ul style="list-style-type: none"> ● Harness or connectors (The sensor circuit is open or shorted) ● Crankshaft position sensor (POS) ● Signal plate

DTC P0335 CKP SENSOR (POS)

UBS00P7L

DTC Confirmation Procedure

NOTE:

If DTC Confirmation Procedure has been previously conducted, always turn ignition switch OFF and wait at least 10 seconds before conducting the next test.

TESTING CONDITION:

Before performing the following procedure, confirm that battery voltage is more than 10.5V with ignition switch ON.

WITH CONSULT-II

1. Turn ignition switch ON and select "DATA MONITOR" mode with CONSULT-II.
2. Crank engine for at least 2 seconds and run it for at least 5 seconds at idle speed.
3. If 1st trip DTC is detected, go to [EC-383, "Diagnostic Procedure"](#)

DATA MONITOR	
MONITOR	NO DTC
ENG SPEED	XXX rpm

SEF058Y

WITH GST

Follow the procedure "WITH CONSULT-II" above.

DTC P0335 CKP SENSOR (POS)

UBS00P7M

EC-POS-01

Wiring Diagram

A
EC
C
D
E
F
G
H
I
J
K
L
M

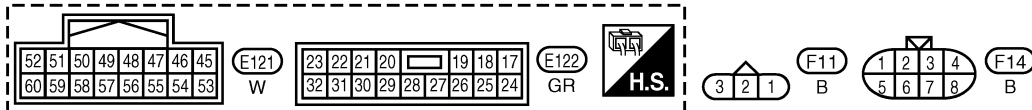
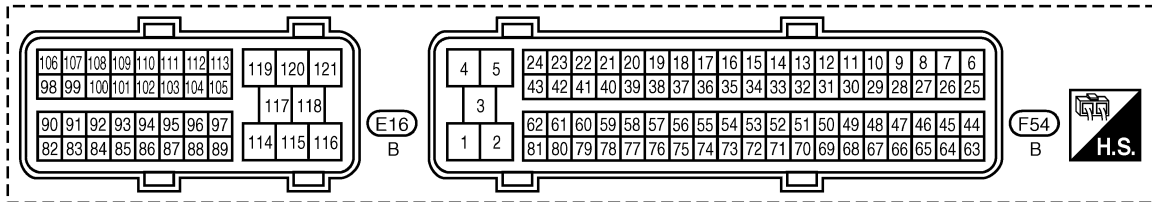
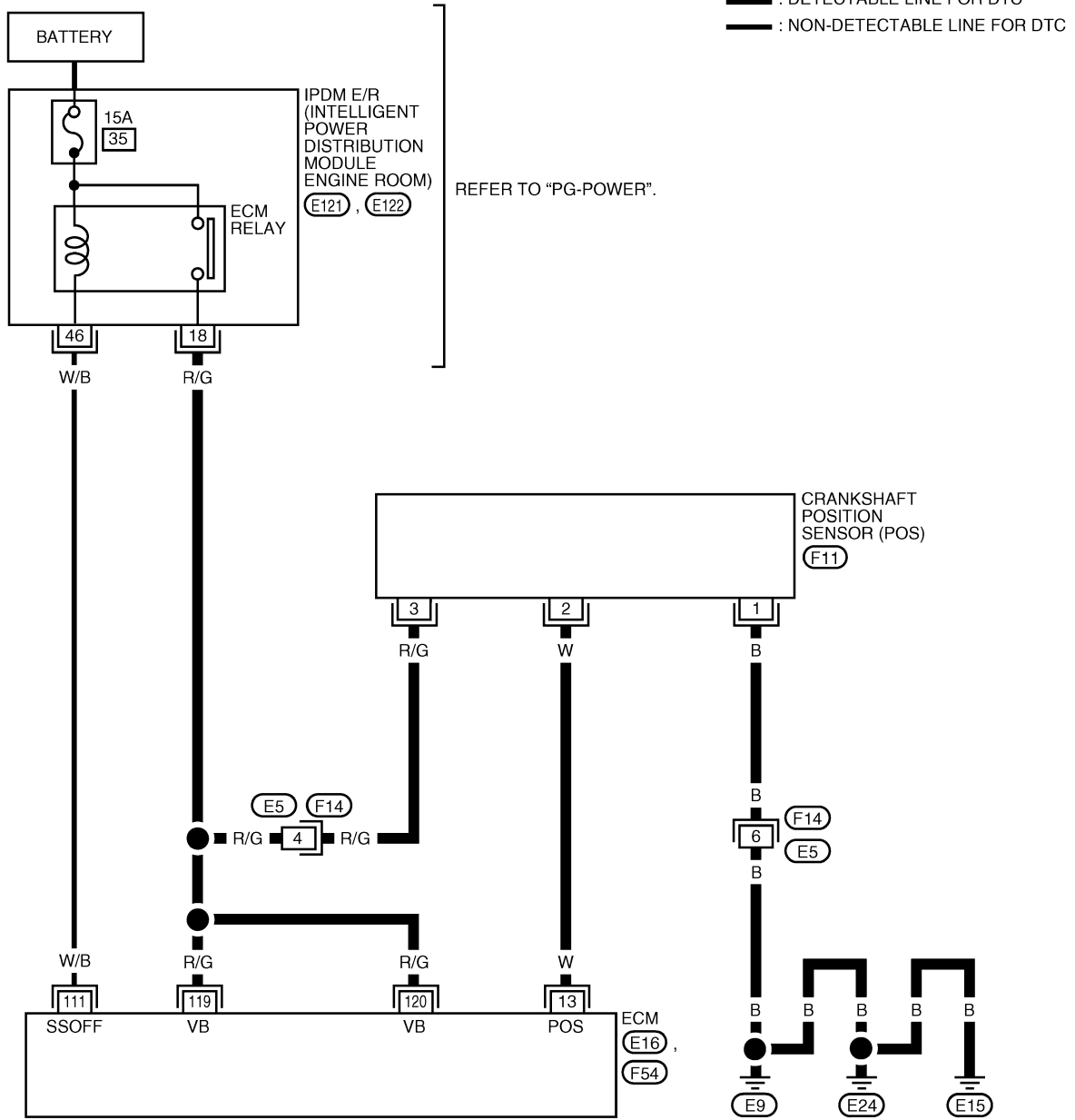

BBWA2518E

DTC P0335 CKP SENSOR (POS)

Specification data are reference values and are measured between each terminal and ground.
Pulse signal is measured by CONSULT-II.

CAUTION:

Do not use ECM ground terminals when measuring input/output voltage. Doing so may result in damage to the ECM's transistor. Use a ground other than ECM terminals, such as the ground.

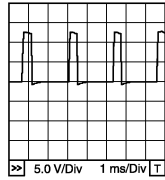
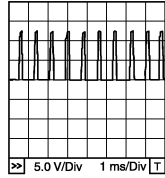
TER-MINAL NO.	WIRE COLOR	ITEM	CONDITION	DATA (DC Voltage)
13	W	Crankshaft position sensor (POS)	[Engine is running] <ul style="list-style-type: none"> ● Warm-up condition ● Idle speed NOTE: The pulse cycle changes depending on rpm at idle	Approximately 10V★  <small>PBIB1041E</small>
			[Engine is running] <ul style="list-style-type: none"> ● Engine speed: 2,000 rpm 	Approximately 10V★  <small>PBIB1042E</small>
111	W/B	ECM relay (Self shut-off)	[Engine is running] [Ignition switch: OFF] <ul style="list-style-type: none"> ● For a few seconds after turning ignition switch OFF 	0 - 1.5V
			[Ignition switch: OFF] <ul style="list-style-type: none"> ● More than a few seconds after turning ignition switch OFF 	BATTERY VOLTAGE (11 - 14V)
119 120	R/G R/G	Power supply for ECM	[Ignition switch: ON]	BATTERY VOLTAGE (11 - 14V)

★: Average voltage for pulse signal (Actual pulse signal can be confirmed by oscilloscope.)

DTC P0335 CKP SENSOR (POS)

UBS00P7N

Diagnostic Procedure

1. CHECK GROUND CONNECTIONS

1. Turn ignition switch OFF.
2. Loosen and retighten three ground screws on the body. Refer to [EC-158, "Ground Inspection"](#).

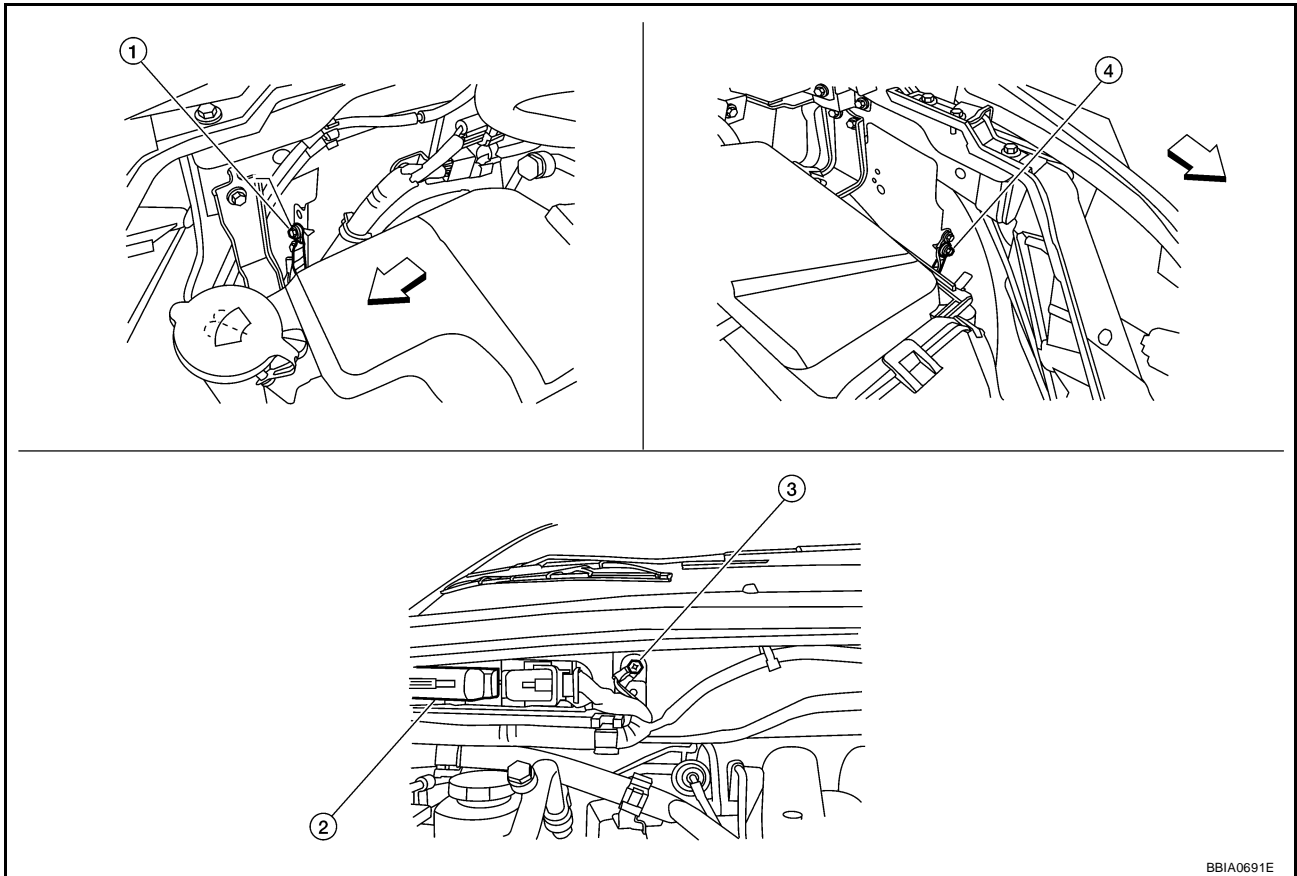

↔ Vehicle front

1. Body ground E24

2. ECM

3. Body ground E9

4. Body ground E15

OK or NG

OK >> GO TO 2.

NG >> Repair or replace ground connections.

DTC P0335 CKP SENSOR (POS)

2. CHECK CRANKSHAFT POSITION (CKP) SENSOR (POS) POWER SUPPLY CIRCUIT

1. Disconnect crankshaft position (CKP) sensor (POS) harness connector.

- ⇐: Vehicle front
- Crankshaft position sensor (POS) (1)
(View from under the vehicle)

2. Turn ignition switch ON.

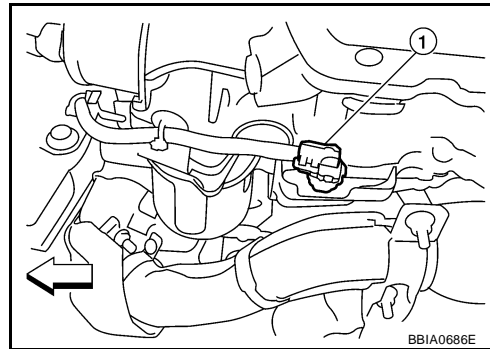

3. Check voltage between CKP sensor (POS) terminal 3 and ground with CONSULT-II or tester.

Voltage: Battery voltage

OK or NG

- OK >> GO TO 4.
- NG >> GO TO 3.

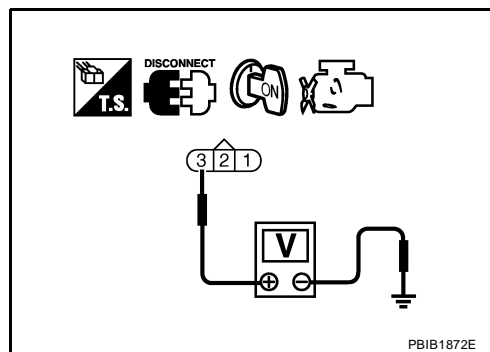

3. DETECT MALFUNCTIONING PART

Check the following.

- Harness connectors E5, F14
- Harness for open or short between crankshaft position sensor (POS) and ECM
- Harness for open or short between crankshaft position sensor (POS) and IPDM E/R

>> Repair open circuit or short to ground or short to power in harness or connectors.

4. CHECK CKP SENSOR (POS) GROUND CIRCUIT FOR OPEN AND SHORT

1. Turn ignition switch OFF.
2. Check harness continuity between CKP sensor (POS) terminal 1 and ground.
Refer to Wiring Diagram.

Continuity should exist.

3. Also check harness for short to power.

OK or NG

- OK >> GO TO 6.
- NG >> GO TO 5.

5. DETECT MALFUNCTIONING PART

Check the following.

- Harness connectors E5, F14
- Harness for open or short between crankshaft position sensor (POS) and ground

>> Repair open circuit or short to power in harness or connectors.

DTC P0335 CKP SENSOR (POS)

6. CHECK CKP SENSOR (POS) INPUT SIGNAL CIRCUIT FOR OPEN AND SHORT

1. Disconnect ECM harness connector.
2. Check harness continuity between ECM terminal 13 and CKP sensor (POS) terminal 2.
Refer to Wiring Diagram.

Continuity should exist.

3. Also check harness for short to ground and short to power.

OK or NG

OK >> GO TO 7.

NG >> Repair open circuit or short to ground or short to power in harness or connectors.

7. CHECK CRANKSHAFT POSITION SENSOR (POS)

Refer to [EC-386, "Component Inspection"](#) .

OK or NG

OK >> GO TO 8.

NG >> Replace crankshaft position sensor (POS).

8. CHECK GEAR TOOTH

Visually check for chipping signal plate gear tooth.

OK or NG

OK >> GO TO 9.

NG >> Replace the signal plate.

9. CHECK INTERMITTENT INCIDENT

Refer to [EC-149, "TROUBLE DIAGNOSIS FOR INTERMITTENT INCIDENT"](#) .

>> INSPECTION END

A

EC

C

D

E

F

G

H

I

J

K

L

M

DTC P0335 CKP SENSOR (POS)

UBS00P7O

Component Inspection CRANKSHAFT POSITION SENSOR (POS)

1. Loosen the fixing bolt of the sensor.
2. Disconnect crankshaft position sensor (POS) harness connector.
3. Remove the sensor.
4. Visually check the sensor for chipping.

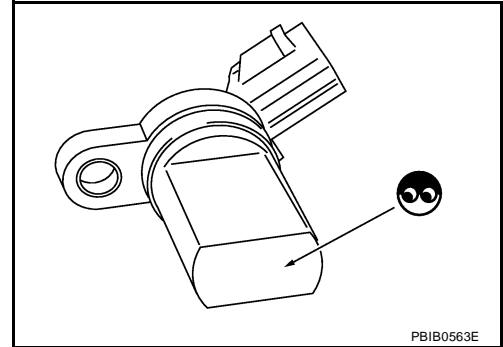

5. Check resistance as shown in the figure.

Terminal No. (Polarity)	Resistance Ω [at 25°C (77°F)]
1 (+) - 2 (-)	Except 0 or ∞
1 (+) - 3 (-)	
2 (+) - 3 (-)	

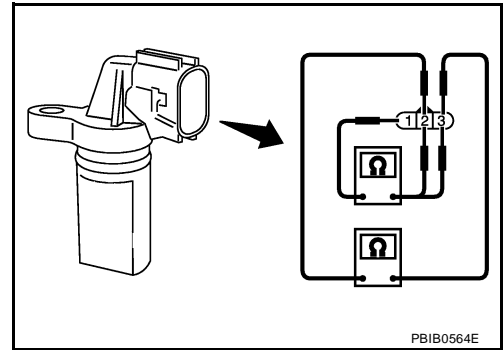

Removal and Installation CRANKSHAFT POSITION SENSOR (POS)

UBS00P7P

Refer to [EM-30, "OIL PAN AND OIL STRAINER"](#) .

DTC P0340, P0345 CMP SENSOR (PHASE)

PFP:23731

UBS00P7Q

DTC P0340, P0345 CMP SENSOR (PHASE)

Component Description

The camshaft position sensor (PHASE) senses the retraction of camshaft (INT) to identify a particular cylinder. The camshaft position sensor (PHASE) senses the piston position.

When the crankshaft position sensor (POS) system becomes inoperative, the camshaft position sensor (PHASE) provides various controls of engine parts instead, utilizing timing of cylinder identification signals.

The sensor consists of a permanent magnet and Hall IC.

When engine is running, the high and low parts of the teeth cause the gap with the sensor to change.

The changing gap causes the magnetic field near the sensor to change.

Due to the changing magnetic field, the voltage from the sensor changes. ECM receives the signals as shown in the figure.

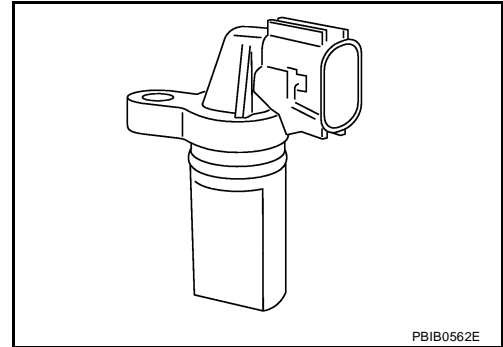

PBIB0562E

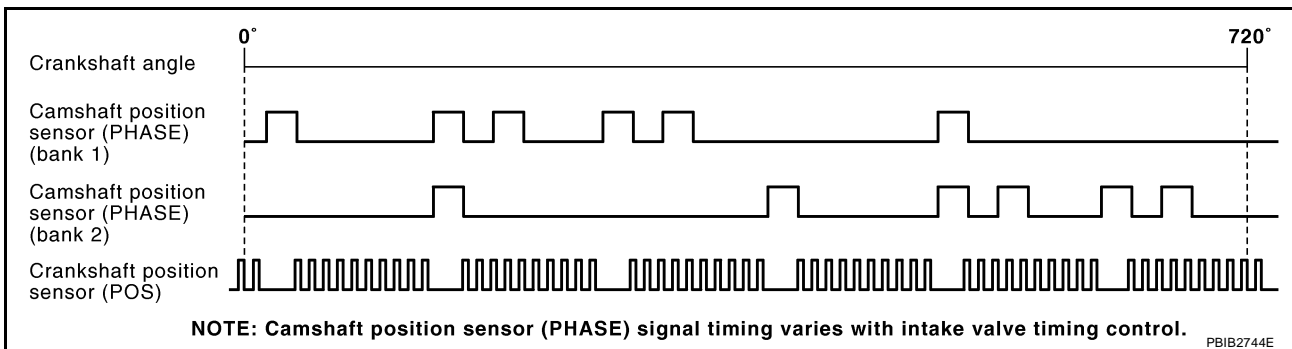

On Board Diagnosis Logic

UBS00P7R

DTC No.	Trouble diagnosis name	DTC detecting condition	Possible cause
P0340 0340 (Bank 1)	Camshaft position sensor (PHASE) circuit	<ul style="list-style-type: none"> The cylinder No. signal is not sent to ECM for the first few seconds during engine cranking. The cylinder No. signal is not sent to ECM during engine running. The cylinder No. signal is not in the normal pattern during engine running. 	<ul style="list-style-type: none"> Harness or connectors (The sensor circuit is open or shorted) Camshaft position sensor (PHASE) Camshaft (Intake) Starter motor (Refer to SC-10, "STARTING SYSTEM" .) Starting system circuit (Refer to SC-10, "STARTING SYSTEM" .) Dead (Weak) battery
P0345 0345 (Bank 2)			

DTC Confirmation Procedure

UBS00P7S

NOTE:

If DTC Confirmation Procedure has been previously conducted, always turn ignition switch OFF and wait at least 10 seconds before conducting the next test.

TESTING CONDITION:

Before performing the following procedure, confirm that battery voltage is more than 10.5V with ignition switch ON.

WITH CONSULT-II

1. Turn ignition switch ON.

DTC P0340, P0345 CMP SENSOR (PHASE)

2. Select "DATA MONITOR" mode with CONSULT-II.
3. Crank engine for at least 2 seconds and run it for at least 5 seconds at idle speed.
4. If 1st trip DTC is detected, go to [EC-392, "Diagnostic Procedure"](#).
If 1st trip DTC is not detected, go to next step.
5. Maintaining engine speed at more than 800 rpm for at least 5 seconds.
6. If 1st trip DTC is detected, go to [EC-392, "Diagnostic Procedure"](#).

DATA MONITOR	
MONITOR	NO DTC
ENG SPEED	XXX rpm

SEF058Y



WITH GST

Follow the procedure "WITH CONSULT-II" above.

DTC P0340, P0345 CMP SENSOR (PHASE)

UBS00P7T

Wiring Diagram BANK 1

EC-PHSB1-01

— : DETECTABLE LINE FOR DTC
— : NON-DETECTABLE LINE FOR DTC

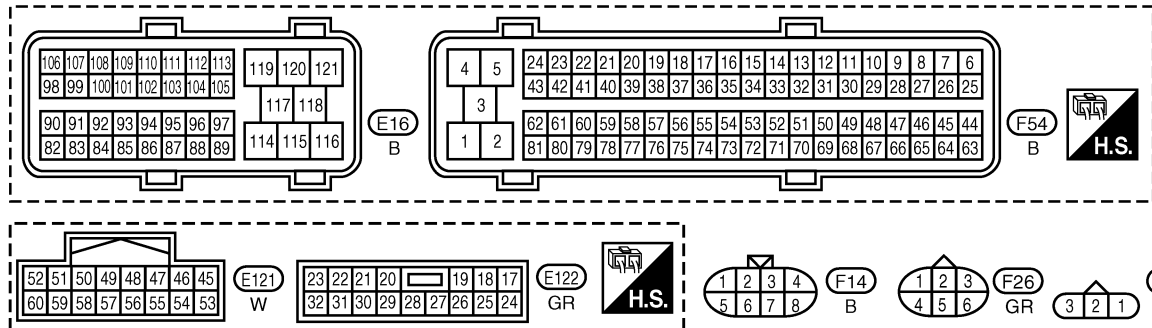
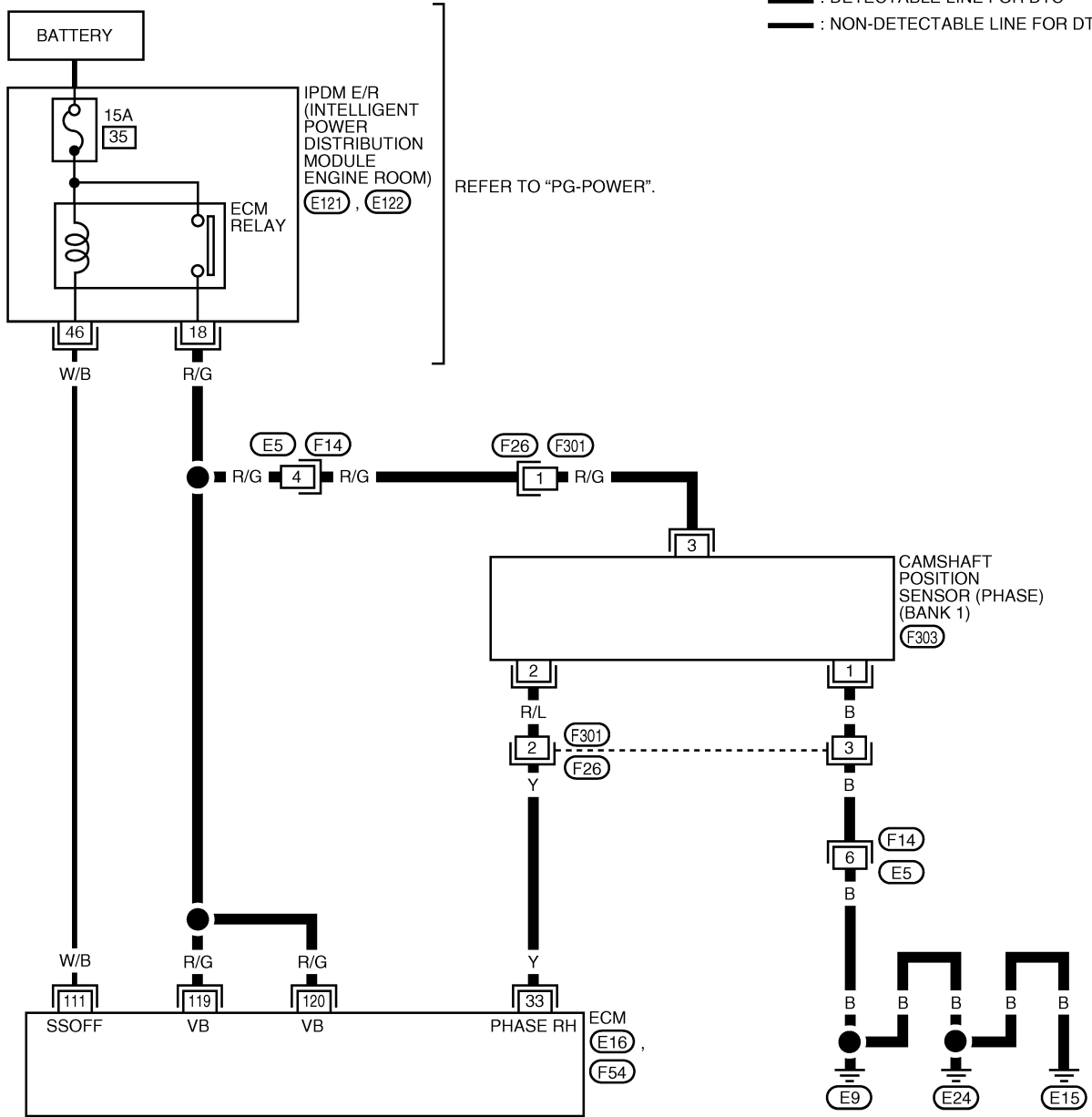

BBWA2519E

DTC P0340, P0345 CMP SENSOR (PHASE)

Specification data are reference values and are measured between each terminal and ground.
Pulse signal is measured by CONSULT-II.

CAUTION:

Do not use ECM ground terminals when measuring input/output voltage. Doing so may result in damage to the ECM's transistor. Use a ground other than ECM terminals, such as the ground.

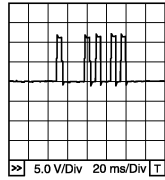
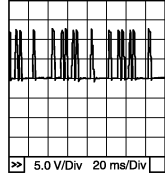
TER-MINAL NO.	WIRE COLOR	ITEM	CONDITION	DATA (DC Voltage)
33	Y	Camshaft position sensor (PHASE) (Bank 1)	[Engine is running] <ul style="list-style-type: none"> ● Warm-up condition ● Idle speed NOTE: The pulse cycle changes depending on rpm at idle	1.0 - 4.0V★  <small>PBIB1039E</small>
			[Engine is running] <ul style="list-style-type: none"> ● Engine speed: 2,000 rpm 	1.0 - 4.0V★  <small>PBIB1040E</small>
111	W/B	ECM relay (Self shut-off)	[Engine is running] [Ignition switch: OFF] <ul style="list-style-type: none"> ● For a few seconds after turning ignition switch OFF 	0 - 1.5V
			[Ignition switch: OFF] <ul style="list-style-type: none"> ● More than a few seconds after turning ignition switch OFF 	BATTERY VOLTAGE (11 - 14V)
119 120	R/G R/G	Power supply for ECM	[Ignition switch: ON]	BATTERY VOLTAGE (11 - 14V)

★: Average voltage for pulse signal (Actual pulse signal can be confirmed by oscilloscope.)

DTC P0340, P0345 CMP SENSOR (PHASE)

BANK 2

EC-PHSB2-01

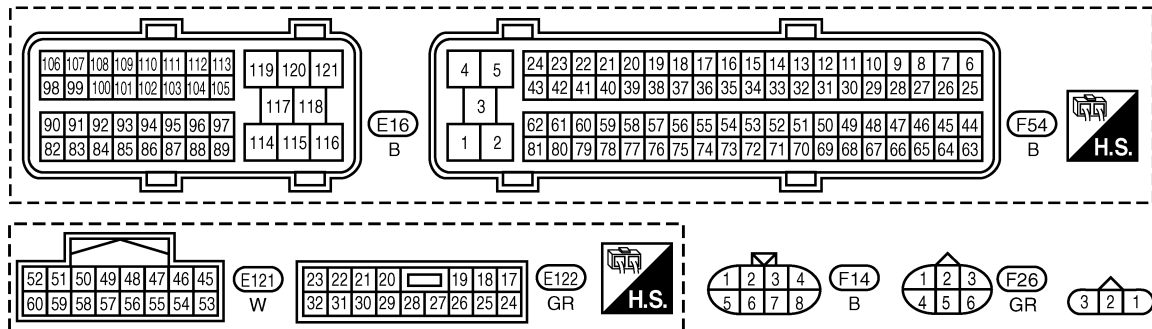
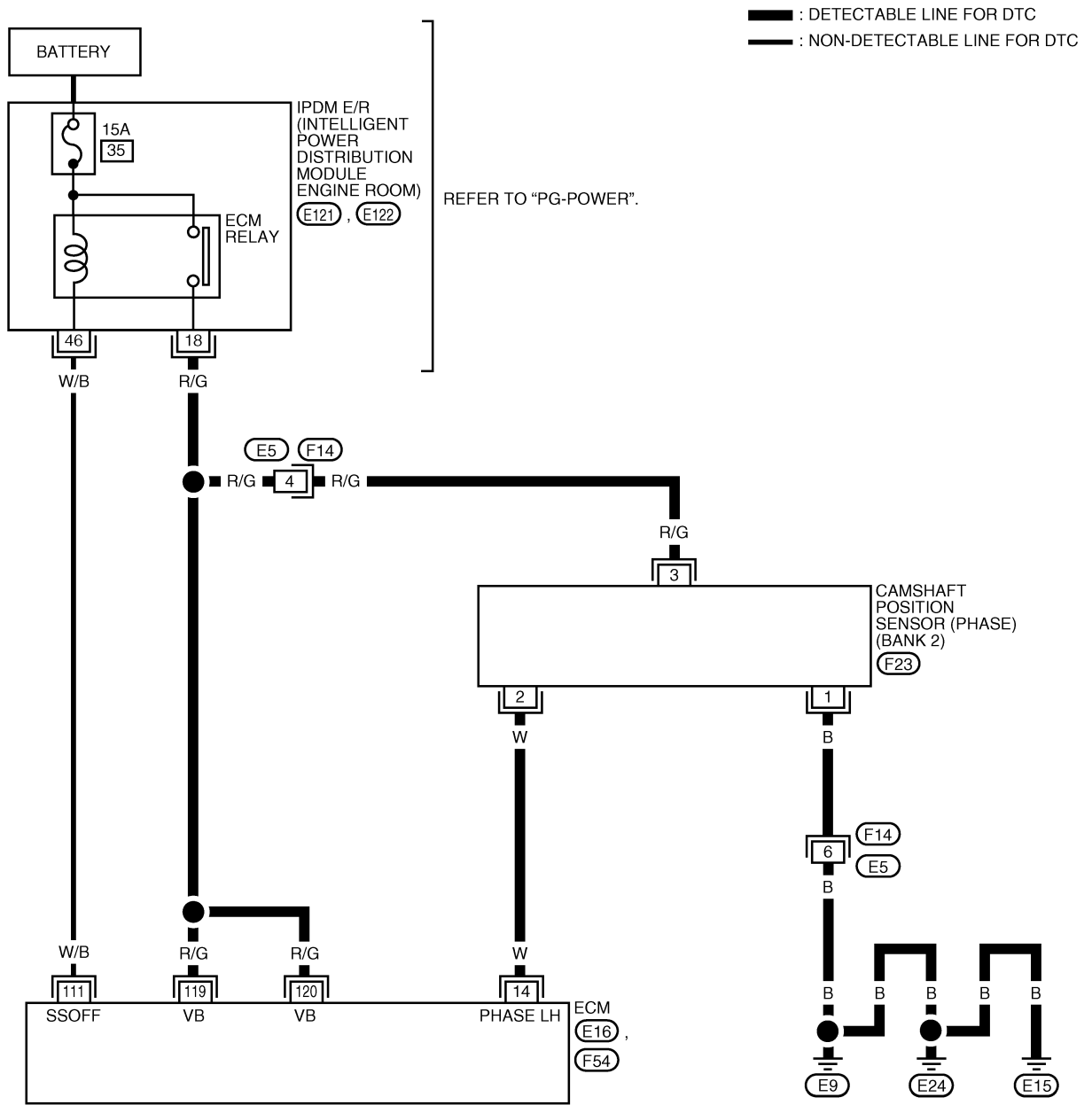

BBWA2520E

DTC P0340, P0345 CMP SENSOR (PHASE)

Specification data are reference values and are measured between each terminal and ground.
Pulse signal is measured by CONSULT-II.

CAUTION:

Do not use ECM ground terminals when measuring input/output voltage. Doing so may result in damage to the ECM's transistor. Use a ground other than ECM terminals, such as the ground.

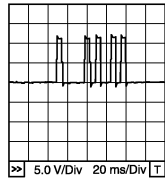
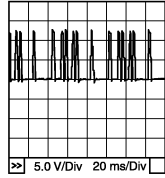
TER-MINAL NO.	WIRE COLOR	ITEM	CONDITION	DATA (DC Voltage)
14	W	Camshaft position sensor (PHASE) (Bank 2)	[Engine is running] <ul style="list-style-type: none"> ● Warm-up condition ● Idle speed NOTE: The pulse cycle changes depending on rpm at idle	1.0 - 4.0V★  <small>5.0 V/Div 20 ms/Div</small> PBIB1039E
			[Engine is running] <ul style="list-style-type: none"> ● Engine speed: 2,000 rpm 	1.0 - 4.0V★  <small>5.0 V/Div 20 ms/Div</small> PBIB1040E
111	W/B	ECM relay (Self shut-off)	[Engine is running] [Ignition switch: OFF] <ul style="list-style-type: none"> ● For a few seconds after turning ignition switch OFF 	0 - 1.5V
			[Ignition switch: OFF] <ul style="list-style-type: none"> ● More than a few seconds after turning ignition switch OFF 	BATTERY VOLTAGE (11 - 14V)
119 120	R/G R/G	Power supply for ECM	[Ignition switch: ON]	BATTERY VOLTAGE (11 - 14V)

★: Average voltage for pulse signal (Actual pulse signal can be confirmed by oscilloscope.)

Diagnostic Procedure

UBS00P7U

1. CHECK STARTING SYSTEM

Turn ignition switch to START position.

Does the engine turn over?

Does the starter motor operate?

Yes or No

Yes >> GO TO 2.

No >> Check starting system. (Refer to [SC-10, "STARTING SYSTEM"](#) .)

DTC P0340, P0345 CMP SENSOR (PHASE)

2. CHECK GROUND CONNECTIONS

1. Turn ignition switch OFF.
2. Loosen and retighten three ground screws on the body. Refer to [EC-158, "Ground Inspection"](#).

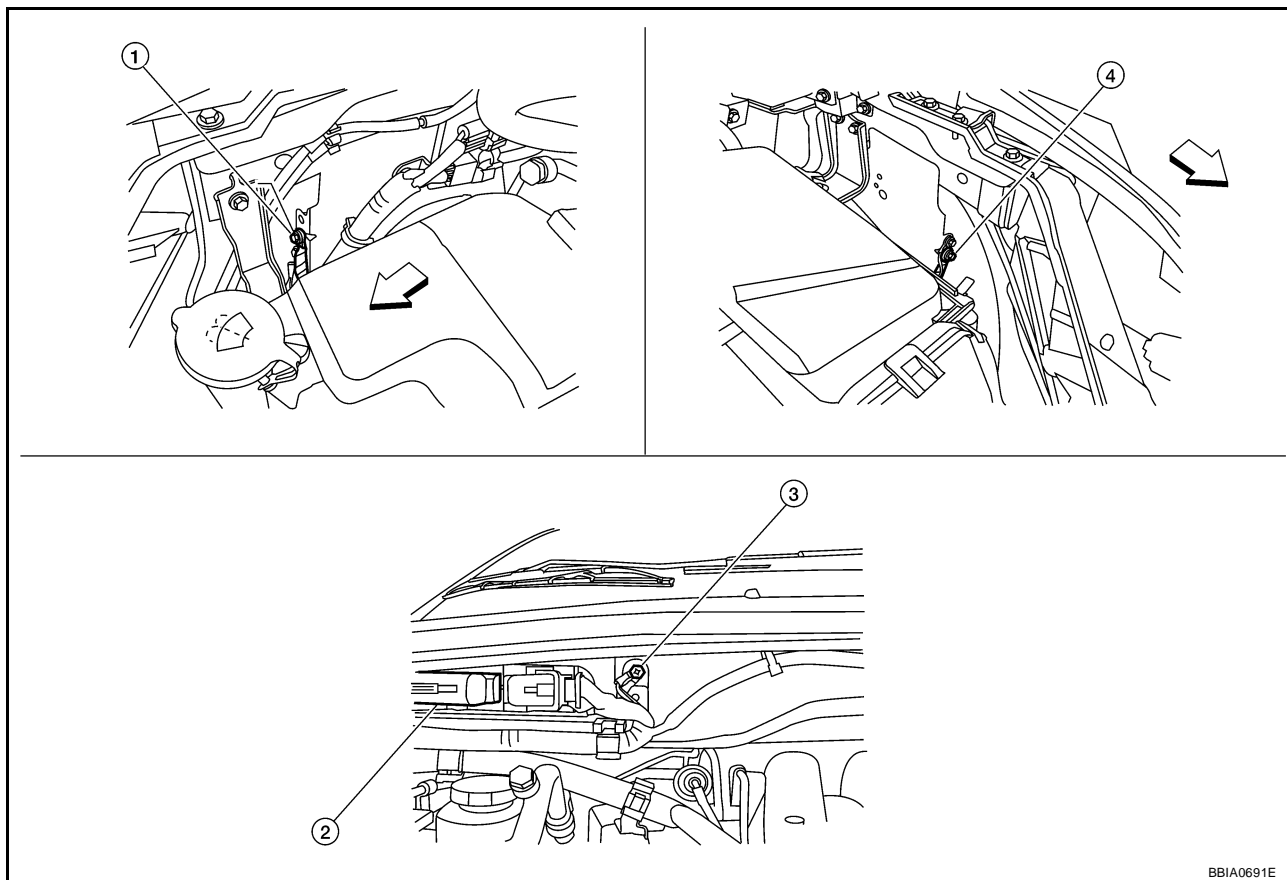

↔ Vehicle front

1. Body ground E24
4. Body ground E15

2. ECM

3. Body ground E9

OK or NG

OK >> GO TO 3.

NG >> Repair or replace ground connections.

A

EC

C

D

E

F

G

H

I

J

K

L

M

DTC P0340, P0345 CMP SENSOR (PHASE)

3. CHECK CAMSHAFT POSITION (CMP) SENSOR (PHASE) POWER SUPPLY CIRCUIT

1. Disconnect camshaft position (CMP) sensor (PHASE) harness connector.

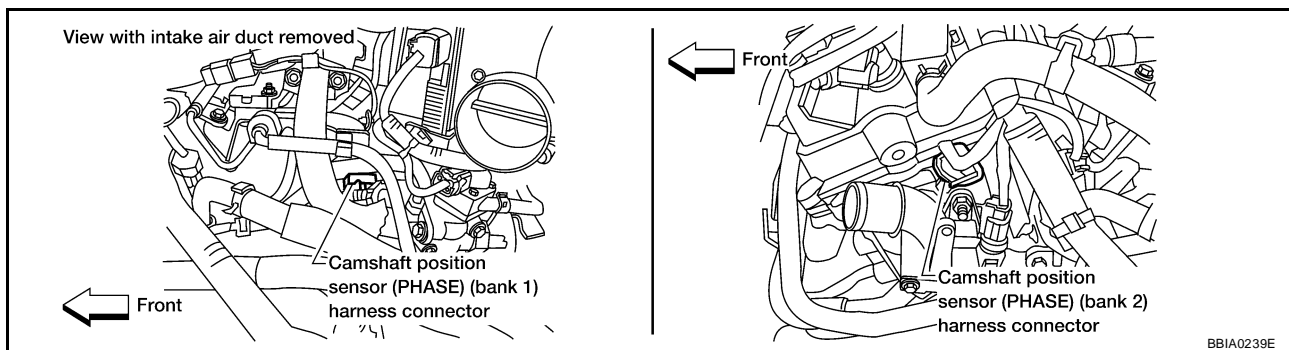

2. Turn ignition switch ON.
3. Check voltage between CMP sensor (PHASE) terminal 3 and ground with CONSULT-II or tester.

Voltage: Battery voltage

OK or NG

- OK >> GO TO 5.
- NG >> GO TO 4.

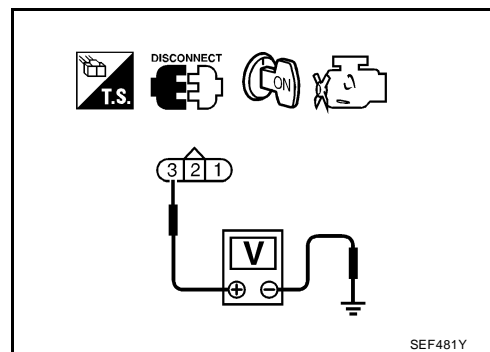

4. DETECT MALFUNCTIONING PART

Check the following.

- Harness connectors E5, F14
- Harness connectors F26, F301 (bank 1)
- Harness for open or short between camshaft position sensor (PHASE) and ECM
- Harness for open or short between camshaft position sensor (PHASE) and IPDM E/R

>> Repair open circuit or short to ground or short to power in harness or connectors.

5. CHECK CMP SENSOR (PHASE) GROUND CIRCUIT FOR OPEN AND SHORT

1. Turn ignition switch OFF.
2. Check harness continuity between CMP sensor (PHASE) terminal 1 and ground. Refer to Wiring Diagram.

Continuity should exist.

3. Also check harness for short to power.

OK or NG

- OK >> GO TO 7.
- NG >> GO TO 6.

DTC P0340, P0345 CMP SENSOR (PHASE)

6. DETECT MALFUNCTIONING PART

Check the following.

- Harness connectors E5, F14
- Harness connectors F26, F301 (bank 1)
- Harness for open or short between CMP sensor (PHASE) and ground

>> Repair open circuit or short to power in harness or connectors.

7. CHECK CMP SENSOR (PHASE) INPUT SIGNAL CIRCUIT FOR OPEN AND SHORT

1. Disconnect ECM harness connector.
2. Check harness continuity between ECM terminal 33 (bank 1) or 14 (bank2) and CMP sensor (PHASE) terminal 2.
Refer to Wiring Diagram.

Continuity should exist.

3. Also check harness for short to ground and short to power.

OK or NG

- OK >> GO TO 9.
- NG >> GO TO 8.

8. DETECT MALFUNCTIONING PART

Check the following.

- Harness connectors F26, F301 (bank 1)
- Harness for open or short between camshaft position sensor (PHASE) and ECM

>> Repair open circuit or short to ground or short to power in harness or connectors.

9. CHECK CAMSHAFT POSITION SENSOR (PHASE)

Refer to [EC-396, "Component Inspection"](#) .

OK or NG

- OK >> GO TO 10.
- NG >> Replace camshaft position sensor (PHASE).

10. CHECK CAMSHAFT (INT)

Check the following.

- Accumulation of debris to the signal plate of camshaft rear end
- Chipping signal plate of camshaft rear end

OK or NG

- OK >> GO TO 11.
- NG >> Remove debris and clean the signal plate of camshaft rear end or replace camshaft.

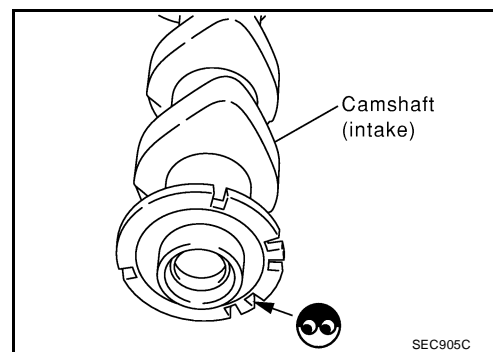

11. CHECK INTERMITTENT INCIDENT

Refer to [EC-149, "TROUBLE DIAGNOSIS FOR INTERMITTENT INCIDENT"](#) .

>> **INSPECTION END**

DTC P0340, P0345 CMP SENSOR (PHASE)

UBS00P7V

Component Inspection CAMSHAFT POSITION SENSOR (PHASE)

1. Loosen the fixing bolt of the sensor.
2. Disconnect camshaft position sensor (PHASE) harness connector.
3. Remove the sensor.
4. Visually check the sensor for chipping.

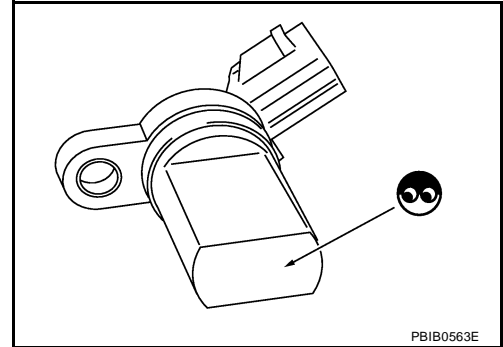

5. Check resistance as shown in the figure.

Terminal No. (Polarity)	Resistance Ω [at 25°C (77°F)]
1 (+) - 2 (-)	Except 0 or ∞
1 (+) - 3 (-)	
2 (+) - 3 (-)	

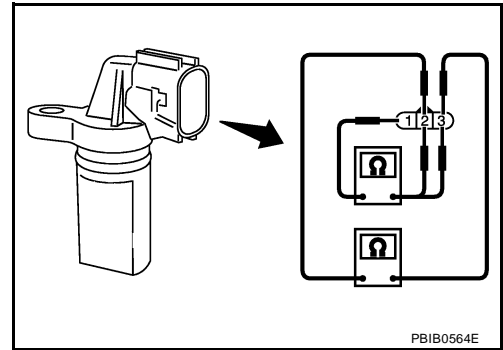

Removal and Installation CAMSHAFT POSITION SENSOR (PHASE)

UBS00P7W

Refer to [EM-78, "CAMSHAFT"](#) .

DTC P0400 EGR FUNCTION

PFP:14710

UBS00P7X

DTC P0400 EGR FUNCTION

Description SYSTEM DESCRIPTION

Sensor	Input Signal to ECM	ECM function	Actuator
Camshaft position sensor (PHASE)	Engine speed*2 Piston position	EGR volume control	EGR volume control valve
Crankshaft position sensor (POS)			
Mass air flow sensor	Amount of intake air		
Engine coolant temperature sensor	Engine coolant temperature		
Throttle position sensor	Throttle position		
Accelerator pedal position sensor	Accelerator pedal position		
Park/neutral position (PNP) switch	Gear position		
Battery	Battery voltage*2		
Air conditioner switch	Air conditioner operation *1		
Power steering pressure sensor	Power steering operation		
Electrical load	Electrical load signal *1		
Wheel sensor	Vehicle speed *1		
TCM	Gear position, shifting signal *1		

*1: This signal is sent to the ECM through CAN communication line.

*2: ECM determines the start signal status by the signals of engine speed and battery voltage.

This system controls flow rate of EGR led from exhaust manifold to intake manifold. The opening of the EGR by-pass passage in the EGR volume control valve changes to control the flow rate. A built-in step motor moves the valve in steps corresponding to the ECM output pulses. The opening of the valve varies for optimum engine control. The optimum value stored in the ECM is determined by considering various engine conditions. The EGR volume control valve remains closed under the following conditions.

- Engine stopped
- Engine starting
- Engine idling
- Low engine coolant temperature
- Excessively high engine coolant temperature
- High engine speed
- Wide open throttle
- Low battery voltage

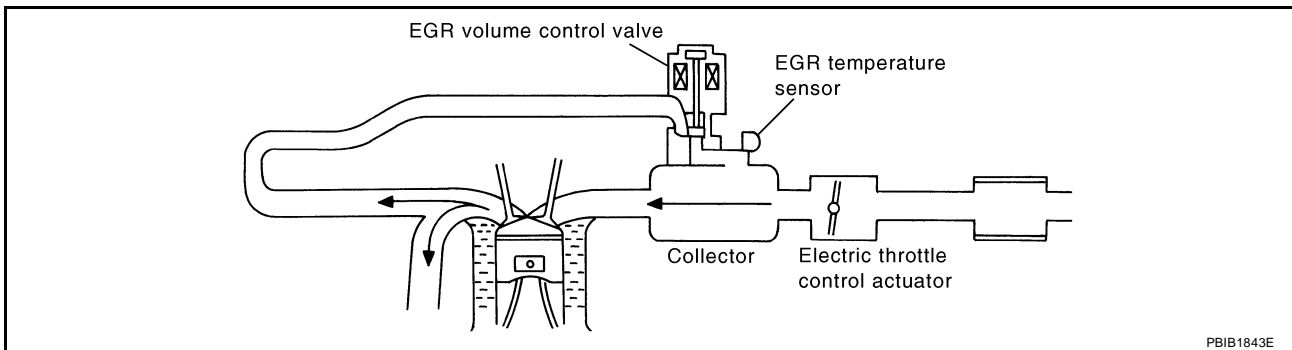

DTC P0400 EGR FUNCTION

COMPONENT DESCRIPTION

EGR Volume Control Valve

The EGR volume control valve uses a step motor to control the flow rate of EGR from exhaust manifold. This motor has four winding phases. It operates according to the output pulse signal of the ECM. Two windings are turned ON and OFF in sequence. Each time an ON pulse is issued, the valve opens or closes, changing the flow rate. When no change in the flow rate is needed, the ECM does not issue the pulse signal. A certain voltage signal is issued so that the valve remains at that particular opening.

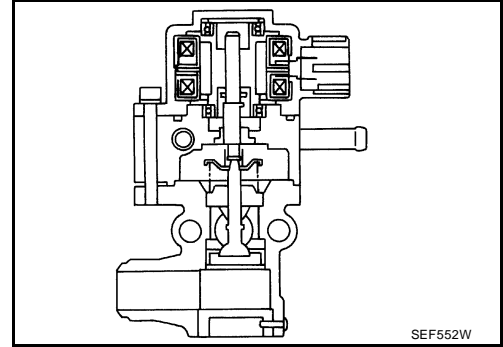

EGR Temperature Sensor

The EGR temperature sensor detects temperature changes in the EGR passageway. When the EGR volume control valve opens, hot exhaust gases flow, and the temperature in the passageway changes. The EGR temperature sensor is a thermistor that modifies a voltage signal sent from the ECM. This modified signal then returns to the ECM as an input signal. As the temperature increases, EGR temperature sensor resistance decreases. This sensor is not directly used to control the engine system. It is used only for the on board diagnosis.

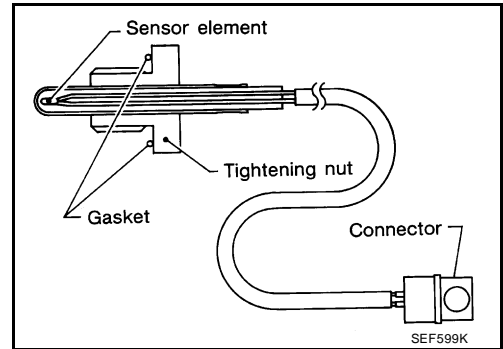

<Reference data>

EGR temperature °C (°F)	Voltage* V	Resistance MΩ
0 (32)	4.59	0.73 - 0.88
50 (122)	2.32	0.074 - 0.082
100 (212)	0.62	0.011 - 0.014

*: This data is reference value and is measured between ECM terminal 54 (EGR temperature sensor) and ground.

CAUTION:

Do not use ECM ground terminals when measuring input/output voltage. Doing so may damage the ECM's transistor. Use a ground other than ECM terminals, such as the ground.

When EGR system is operating.

Voltage: 0 - 1.5V

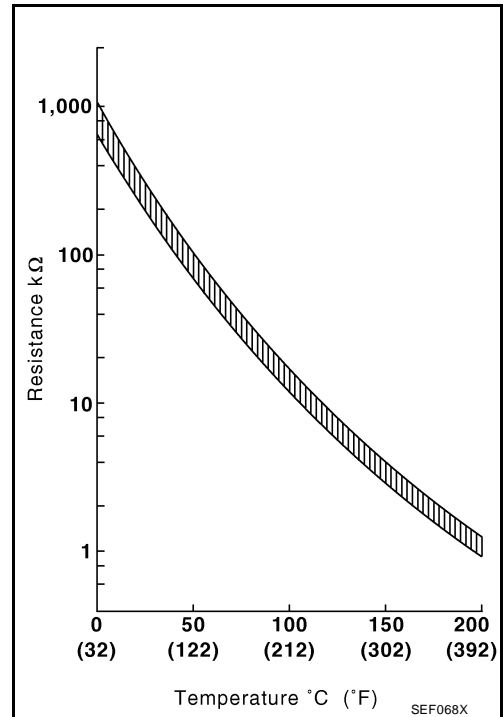

DTC P0400 EGR FUNCTION

CONSULT-II Reference Value in Data Monitor Mode

UBS00P7Y

Specification data are reference values.

MONITOR ITEM	CONDITION		SPECIFICATION
EGR TEMP SEN	● Engine: After warming up		Less than 4.5V
EGR VOL CON/V	● Engine: After warming up	Idle	0 step
	● Air conditioner switch: OFF ● Shift lever: P or N ● No load	Revving engine up to 3,000 rpm quickly	10 - 55 step

On Board Diagnosis Logic

UBS00P7Z

If the absence of EGR flow is detected by EGR temperature sensor under the condition that calls for EGR, a low-flow malfunction is diagnosed.

DTC No.	Trouble diagnosis name	DTC detecting condition	Possible cause
P0400 0400	EGR function (Close)	No EGR flow is detected under the condition that calls for EGR.	<ul style="list-style-type: none"> ● Harness or connectors (The EGR volume control valve circuit is open or shorted.) ● EGR volume control valve stuck closed ● Dead (Weak) battery ● EGR passage clogged ● EGR temperature sensor and circuit ● Exhaust gas leaks

DTC Confirmation Procedure

UBS00P80

CAUTION:

Always drive vehicle at a safe speed.

NOTE:

- If DTC Confirmation Procedure has been previously conducted, always turn ignition switch OFF and wait at least 5 seconds before conducting the next test.
- P0400 will not be displayed at "SELF-DIAG RESULTS" mode with CONSULT-II even though DTC work support test result is NG.

TESTING CONDITION:

- Before performing the following procedure, confirm battery voltage is more than 10V at idle, then stop engine immediately.
- For best results, perform the test at a temperature of 5°C (41°F) or higher.

Ⓟ WITH CONSULT-II

1. Turn ignition switch OFF, wait at least 10 seconds and then turn ON.

2. Check "COOLAN TEMP/S" in "DATA MONITOR" mode with CONSULT-II.
Confirm "COOLAN TEMP/S" value is within the range listed below.

COOLAN TEMP/S: Less than 40°C (104°F)

If the value is out of range, park the vehicle in a cool place and allow the engine temperature to stabilize. Do not attempt to lower the engine coolant temperature with a fan or means other than ambient air. Doing so may produce an inaccurate diagnostic result.

3. Start engine and let it idle monitoring "COOLAN TEMP/S" value. When the "COOLAN TEMP/S" value reaches 70°C (158°F), immediately go to the next step.

4. Select "EGR SYSTEM P0400" of "EGR SYSTEM" in "DTC WORK SUPPORT" mode with CONSULT-II.

5. Touch "START".

6. Accelerate vehicle to a speed of 40 km/h (25 MPH) once and then stop vehicle with engine running.
If "COMPLETED" appears on CONSULT-II screen, go to step 8.

DATA MONITOR	
MONITOR	NO DTC
COOLAN TEMP/S	XXX °C

SEF013Y

DTC P0400 EGR FUNCTION

If "COMPLETED" does not appear on CONSULT-II screen, go to the following step.

7. When the following conditions are met, "TESTING" will be displayed on the CONSULT-II screen. Maintain the conditions until "TESTING" changes to "COMPLETED". (It will take approximately 30 seconds or more.)

ENG SPEED	1,200 - 2,800 rpm
VHCL SPEED SE	More than 10 km/h (6 MPH)
B/FUEL SCHDL	4 - 9 msec
Shift lever	Suitable position

EGR SYSTEM P0400	
OUT OF CONDITION	
MONITOR	
ENG SPEED	XXX rpm
B/FUEL SCHDL	XXX msec
COOLAN TEMP/S	XXX °C
VHCL SPEED SE	XXX km/h

SEF845Y

If "TESTING" is not displayed after 5 minutes, retry from step 2.

8. Make sure that "OK" is displayed after touching "SELF-DIAG RESULTS". If "NG" is displayed, refer to [EC-402, "Diagnostic Procedure"](#).

WITH GST

1. Turn ignition switch OFF, wait at least 10 seconds and then turn ON.
2. Check engine coolant temperature in Service \$01 with GST.
Engine coolant temperature: Less than 40°C (104°F)
If the value is out of range, park the vehicle in a cool place and allow the engine temperature to stabilize. Do not attempt to lower the coolant temperature with a fan or means other than ambient air. Doing so may produce an inaccurate diagnostic result.
3. Start engine and let it idle monitoring the engine coolant temperature value. When the engine coolant temperature reaches 70°C (158°F), immediately go to the next step.
4. Maintain the following conditions for at least 1 minute.
Engine speed: 1,200 - 2,800 rpm
Vehicle speed: More than 10 km/h (6 MPH)
Shift lever: Suitable position
5. Stop vehicle.
6. Turn ignition switch OFF, wait at least 10 seconds and then turn ON.
7. Select Service \$07 with GST.
8. If 1st trip DTC is detected, go to [EC-402, "Diagnostic Procedure"](#).

DTC P0400 EGR FUNCTION

UBS00P81

Wiring Diagram

EC-EGRC1-01

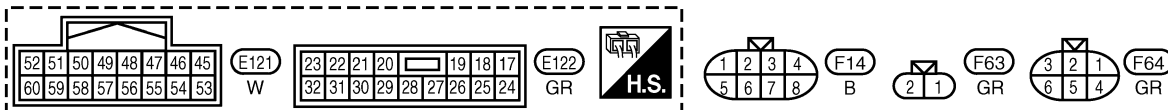
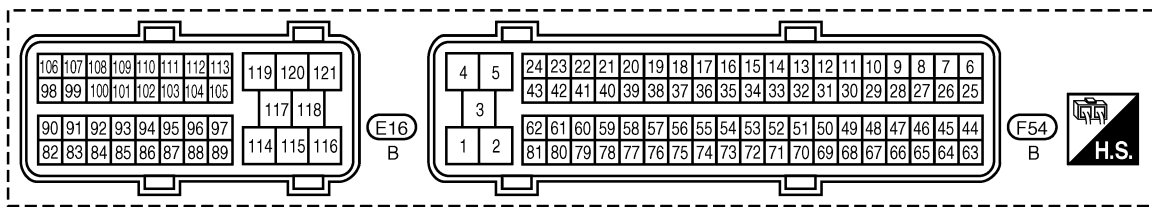
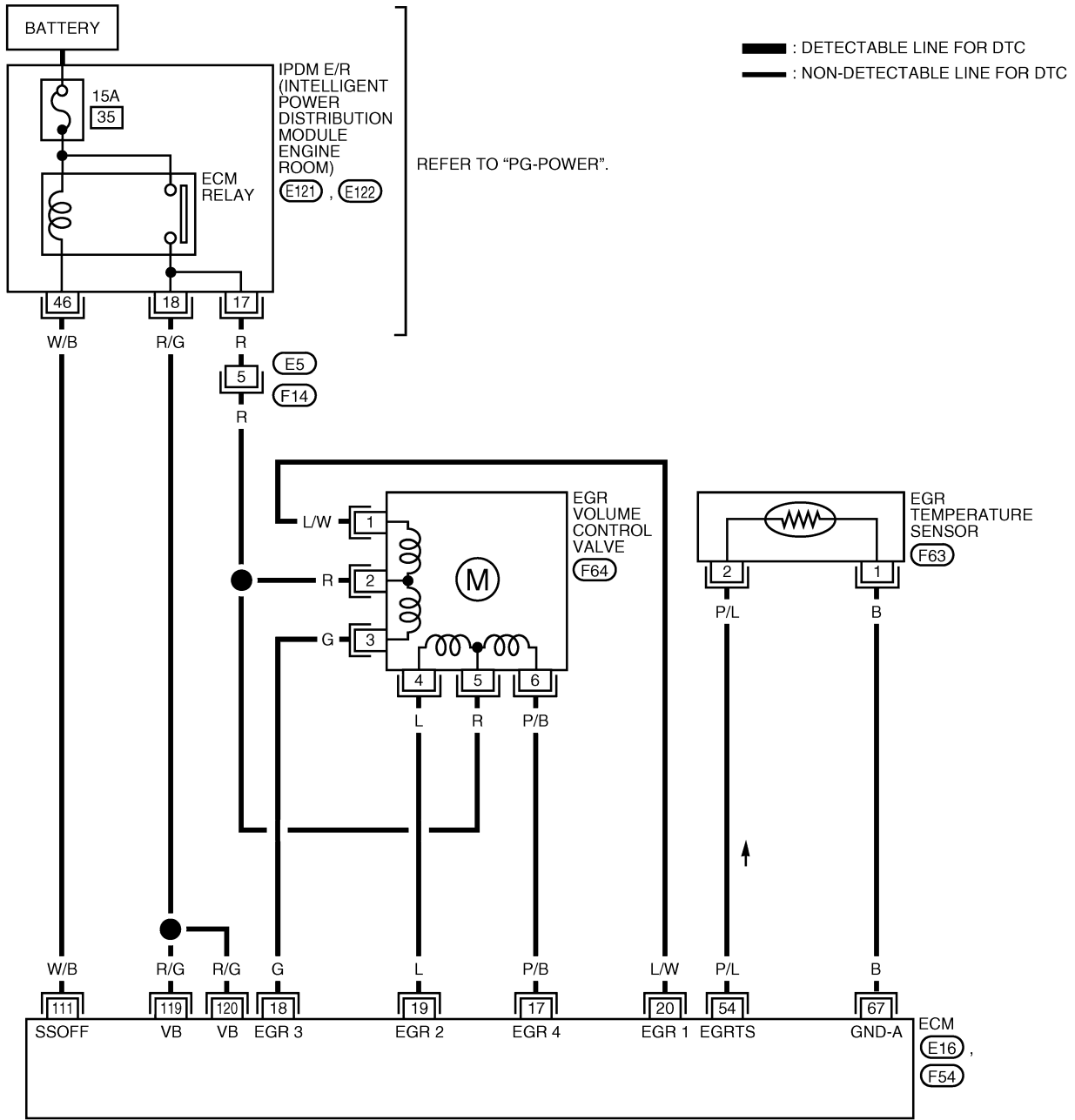

BBWA2547E

DTC P0400 EGR FUNCTION

Specification data are reference values and are measured between each terminal and ground.

CAUTION:

Do not use ECM ground terminals when measuring input/output voltage. Doing so may result in damage to the ECM's transistor. Use a ground other than ECM terminals, such as the ground.

TER-MINAL NO.	WIRE COLOR	ITEM	CONDITION	DATA (DC Voltage)
17 18 19 20	P/B G L L/W	EGR volume control valve	[Engine is running] ● Idle speed	0.1 - 14V
54	P/L	EGR temperature sensor	[Ignition switch: ON]	Less than 4.5V
			[Engine is running] ● Warm-up condition ● EGR system: Operating	0 - 1.5V
67	B	Sensor ground	[Engine is running] ● Warm-up condition ● Idle speed	Approximately 0V
111	W/B	ECM relay (Self shut-off)	[Engine is running] [Ignition switch: OFF] ● For a few seconds after turning ignition switch OFF	0 - 1.5V
			[Ignition switch: OFF] ● More than a few seconds after turning ignition switch OFF	BATTERY VOLTAGE (11 - 14V)
119 120	R/G R/G	Power supply for ECM	[Ignition switch: ON]	BATTERY VOLTAGE (11 - 14V)

Diagnostic Procedure

UBS00P82

1. CHECK EXHAUST SYSTEM

1. Start engine.
2. Check exhaust pipes and muffler for leaks.

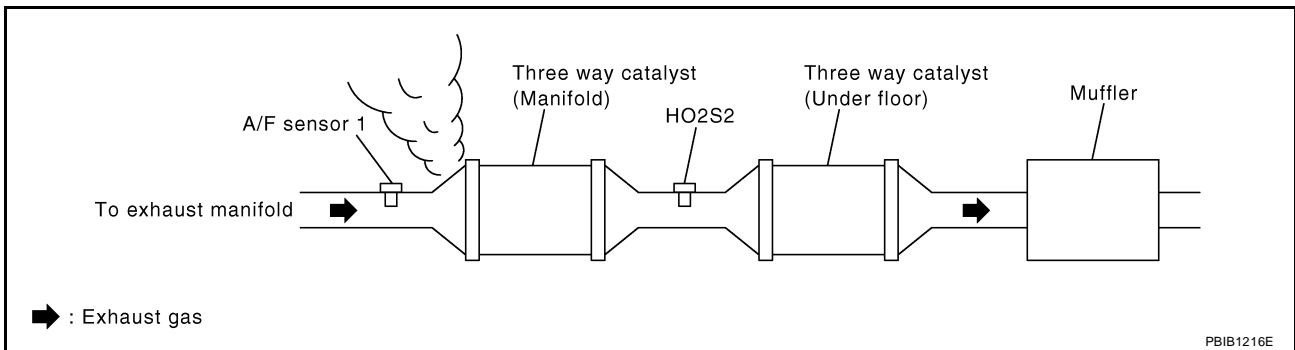

OK or NG

- OK >> GO TO 2.
- NG >> Repair or replace exhaust system.

DTC P0400 EGR FUNCTION

2. CHECK EGR VOLUME CONTROL VALVE POWER SUPPLY CIRCUIT

1. Turn ignition switch OFF.
2. Disconnect EGR volume control valve harness connector.
3. Turn ignition switch ON.

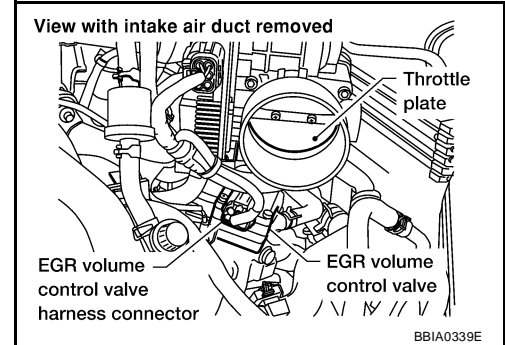

4. Check voltage between EGR volume control valve terminals 2, 5 and ground with CONSULT-II or tester.

Voltage: Battery voltage

OK or NG

- OK >> GO TO 4.
- NG >> GO TO 3.

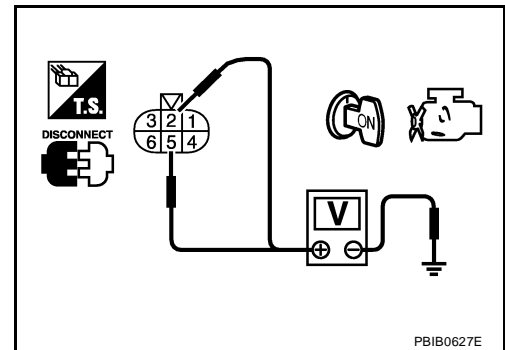

3. DETECT MALFUNCTIONING PART

Check the following.

- Harness connectors E5, F14
- Harness for open or short between EGR volume control valve and IPDM E/R

>> Repair harness or connectors.

4. CHECK EGR VOLUME CONTROL VALVE OUTPUT SIGNAL CIRCUIT FOR OPEN AND SHORT

1. Turn ignition switch OFF.
2. Disconnect ECM harness connector.
3. Check harness continuity between ECM terminals and EGR volume control valve terminals as follows. Refer to Wiring Diagram.

ECM terminal	EGR volume control valve
17	6
18	3
19	4
20	1

Continuity should exist.

4. Also check harness for short to ground and short to power.

OK or NG

- OK >> GO TO 5.
- NG >> Repair open circuit or short to ground or short to power in harness or connectors.

DTC P0400 EGR FUNCTION

5. CHECK EGR PASSAGE

Check EGR passage for clogging and cracks.

OK or NG

OK >> GO TO 6.

NG >> Repair or replace EGR passage.

6. CHECK EGR VOLUME CONTROL VALVE

Refer to [EC-409, "Component Inspection"](#).

OK or NG

OK >> GO TO 7.

NG >> Replace EGR volume control valve.

7. CHECK EGR TEMPERATURE SENSOR AND CIRCUIT

Perform DTC Confirmation Procedure for DTC P0405, P0406. Refer to [EC-413, "DTC Confirmation Procedure"](#).

OK or NG

OK >> GO TO 8.

NG >> Repair or replace malfunctioning part.

8. CHECK INTERMITTENT INCIDENT

Refer to [EC-149, "TROUBLE DIAGNOSIS FOR INTERMITTENT INCIDENT"](#).

>> **INSPECTION END**

DTC P0403 EGR VOLUME CONTROL VALVE

PDF:14710

UBS00P83

DTC P0403 EGR VOLUME CONTROL VALVE

Description SYSTEM DESCRIPTION

Sensor	Input Signal to ECM	ECM function	Actuator
Camshaft position sensor (PHASE)	Engine speed*2 Piston position	EGR volume control	EGR volume control valve
Crankshaft position sensor (POS)			
Mass air flow sensor	Amount of intake air		
Engine coolant temperature sensor	Engine coolant temperature		
Throttle position sensor	Throttle position		
Accelerator pedal position sensor	Accelerator pedal position		
Park/neutral position (PNP) switch	Gear position		
Battery	Battery voltage*2		
Air conditioner switch	Air conditioner operation *1		
Power steering pressure sensor	Power steering operation		
Electrical load	Electrical load signal *1		
Wheel sensor	Vehicle speed *1		
TCM	Gear position, shifting signal *1		

*1: This signal is sent to the ECM through CAN communication line.

*2: ECM determines the start signal status by the signals of engine speed and battery voltage.

This system controls flow rate of EGR led from exhaust manifold to intake manifold. The opening of the EGR by-pass passage in the EGR volume control valve changes to control the flow rate. A built-in step motor moves the valve in steps corresponding to the ECM output pulses. The opening of the valve varies for optimum engine control. The optimum value stored in the ECM is determined by considering various engine conditions. The EGR volume control valve remains close under the following conditions.

- Engine stopped
- Engine starting
- Engine idling
- Low engine coolant temperature
- Excessively high engine coolant temperature
- High engine speed
- Wide open throttle
- Low battery voltage

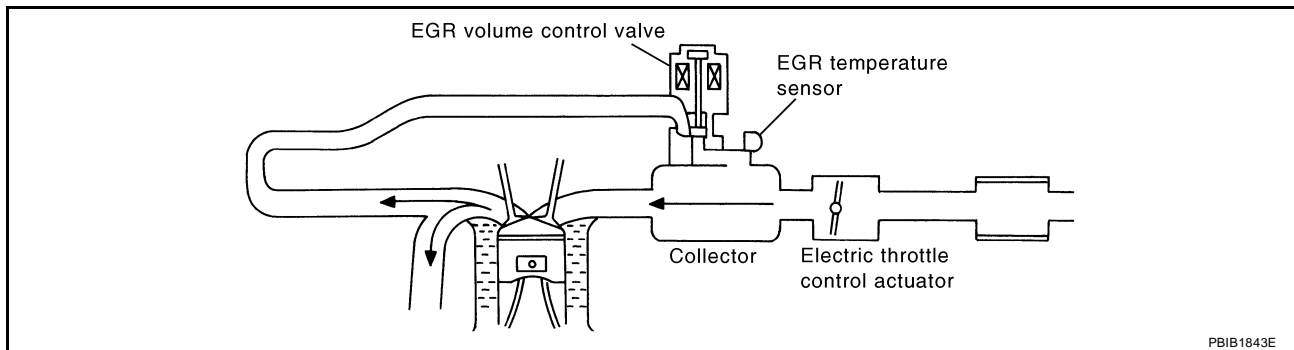

PBIB1843E

DTC P0403 EGR VOLUME CONTROL VALVE

COMPONENT DESCRIPTION

EGR Volume Control Valve

The EGR volume control valve uses a step motor to control the flow rate of EGR from exhaust manifold. This motor has four winding phases. It operates according to the output pulse signal of the ECM. Two windings are turned ON and OFF in sequence. Each time an ON pulse is issued, the valve opens or closes, changing the flow rate. When no change in the flow rate is needed, the ECM does not issue the pulse signal. A certain voltage signal is issued so that the valve remains at that particular opening.

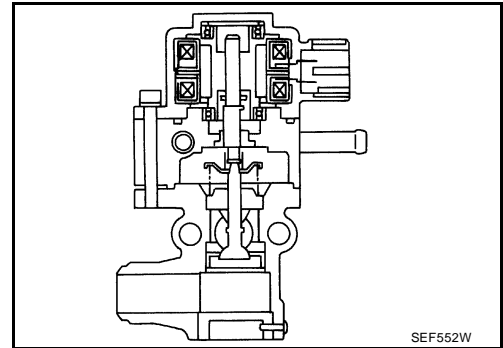

SEF552W

CONSULT-II Reference Value in Data Monitor Mode

UBS00P84

Specification data are reference values.

MONITOR ITEM	CONDITION	SPECIFICATION
EGR VOL CON/V	<ul style="list-style-type: none"> ● Engine: After warming up ● Air conditioner switch: OFF ● Shift lever: P or N ● No load 	Idle
	Revsing engine up to 3,000 rpm quickly	10 - 55 step

On Board Diagnosis Logic

UBS00P85

This self-diagnosis has the one trip detection logic.

DTC No.	Trouble diagnosis name	DTC detecting condition	Possible cause
P0403 0403	EGR volume control valve circuit	An improper voltage signal is sent to ECM through the valve	<ul style="list-style-type: none"> ● Harness or connectors (The EGR volume control valve circuit is open or shorted.) ● EGR volume control valve

DTC Confirmation Procedure

UBS00P86

NOTE:

If DTC Confirmation Procedure has been previously conducted, always turn ignition switch OFF and wait at least 10 seconds before conducting the next test.

TESTING CONDITION:

Before performing the following procedure, confirm that battery voltage is more than 10V at idle.

WITH CONSULT-II

1. Turn ignition switch ON and select "DATA MONITOR" mode with CONSULT-II.
2. Start engine and warm it up to normal operating temperature.
3. Rev engine from idle to 2,000 rpm for 10 times.
4. If DTC is detected, go to [EC-408, "Diagnostic Procedure"](#).

DATA MONITOR	
MONITOR	NO DTC
ENG SPEED	XXX rpm
COOLAN TEMP/S	XXX °C

SEF174Y

WITH GST

Follow the procedure "WITH CONSULT-II" above.

DTC P0403 EGR VOLUME CONTROL VALVE

UBS00P87

Wiring Diagram

EC-EGVC/V-01

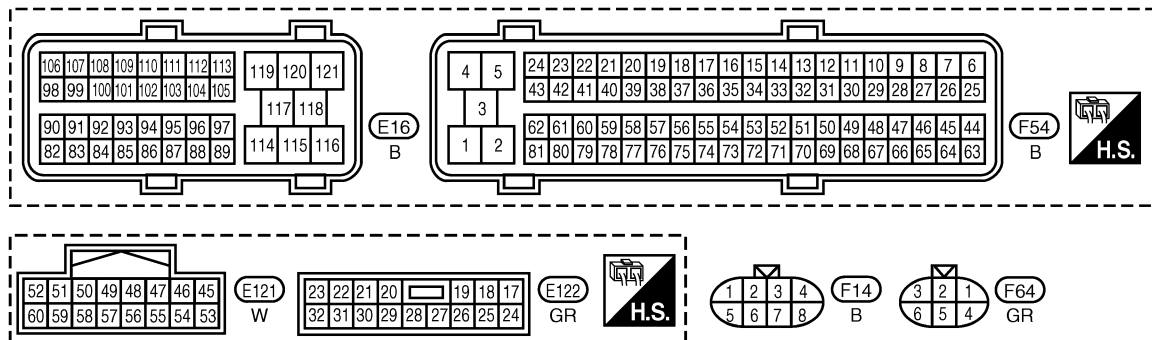
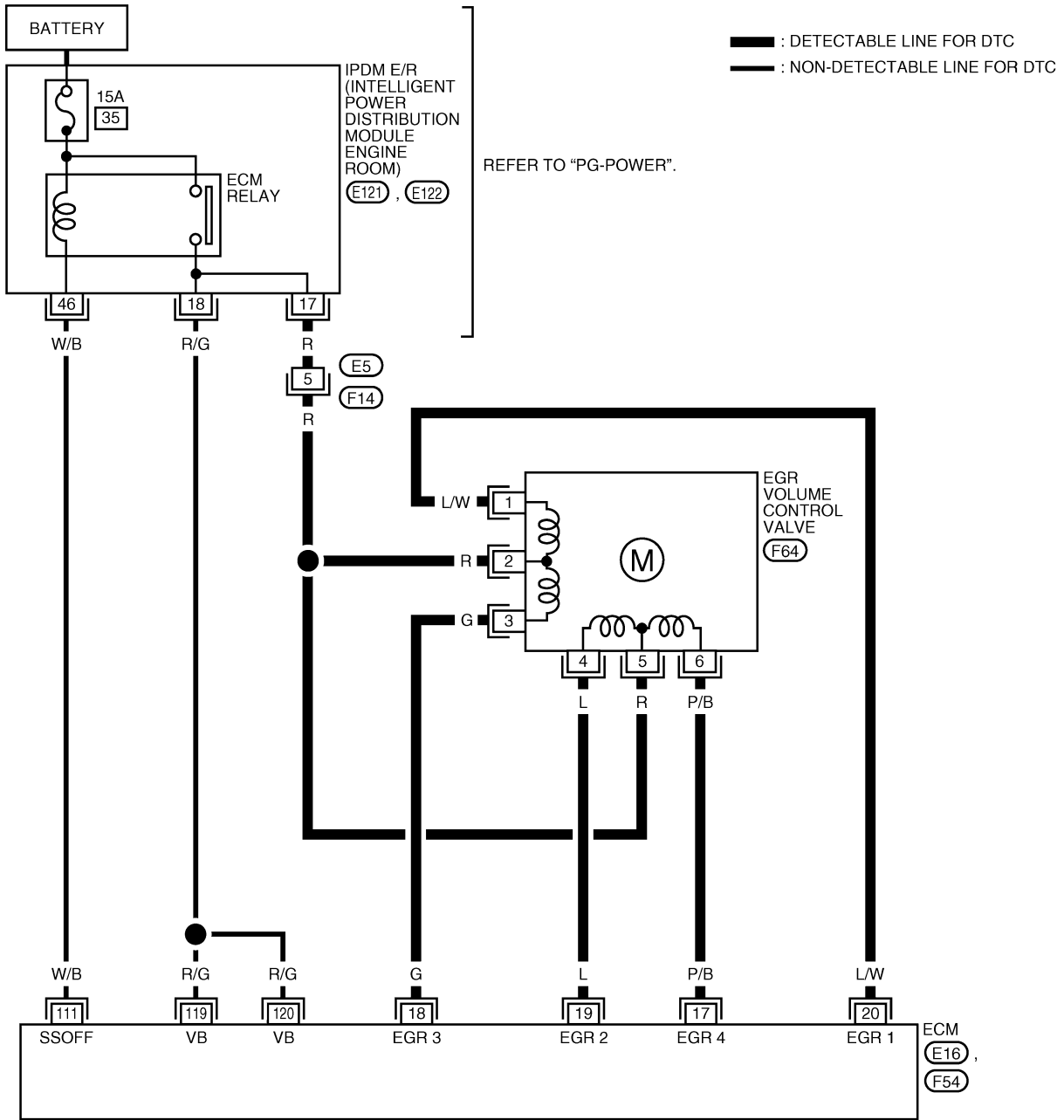

BBWA2546E

DTC P0403 EGR VOLUME CONTROL VALVE

Specification data are reference values and are measured between each terminal and ground.

CAUTION:

Do not use ECM ground terminals when measuring input/output voltage. Doing so may result in damage to the ECM's transistor. Use a ground other than ECM terminals, such as the ground.

TER-MINAL NO.	WIRE COLOR	ITEM	CONDITION	DATA (DC Voltage)
17 18 19 20	P/B G L L/W	EGR volume control valve	[Engine is running] ● Idle speed	0.1 - 14V
111	W/B	ECM relay (Self shut-off)	[Engine is running] [Ignition switch: OFF] ● For a few seconds after turning ignition switch OFF	0 - 1.5V
			[Ignition switch: OFF] ● More than a few seconds passed after turning ignition switch OFF	BATTERY VOLTAGE (11 - 14V)
119 120	R/G R/G	Power supply for ECM	[Ignition switch: ON]	BATTERY VOLTAGE (11 - 14V)

Diagnostic Procedure

UBS00P88

1. CHECK EGR VOLUME CONTROL VALVE POWER SUPPLY CIRCUIT

1. Turn ignition switch OFF.
2. Disconnect EGR volume control valve harness connector.
3. Turn ignition switch ON.

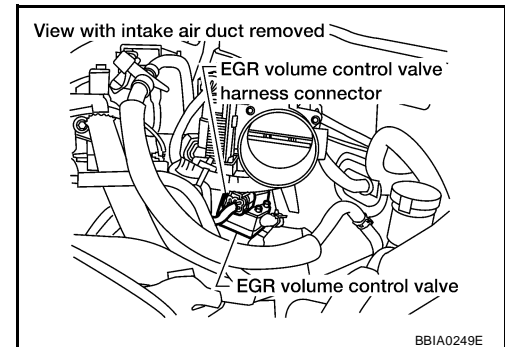

4. Check voltage between EGR volume control valve terminals 2, 5 and ground with CONSULT-II or tester.

Voltage: Battery voltage

OK or NG

- OK >> GO TO 3.
- NG >> GO TO 2.

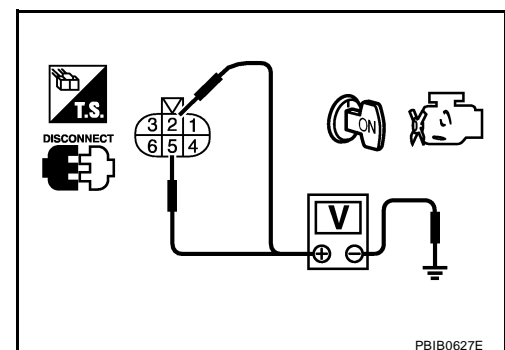

2. DETECT MALFUNCTIONING PART

Check the following.

- Harness connectors E5, F14
- Harness for open or short between EGR volume control valve and IPDM E/R

>> Repair harness or connectors.

DTC P0403 EGR VOLUME CONTROL VALVE

3. CHECK EGR VOLUME CONTROL VALVE OUTPUT SIGNAL CIRCUIT FOR OPEN AND SHORT

1. Turn ignition switch OFF.
2. Disconnect ECM harness connector.
3. Check harness continuity between ECM terminals and EGR volume control valve terminals as follows. Refer to Wiring Diagram.

ECM terminal	EGR volume control valve
17	6
18	3
19	4
20	1

Continuity should exist.

4. Also check harness for short to ground and short to power.

OK or NG

OK >> GO TO 4.

NG >> Repair open circuit or short to ground or short to power in harness or connectors.

4. CHECK EGR VOLUME CONTROL VALVE

Refer to [EC-409, "Component Inspection"](#) .

OK or NG

OK >> GO TO 5.

NG >> Replace EGR volume control valve.

5. CHECK INTERMITTENT INCIDENT

Refer to [EC-149, "TROUBLE DIAGNOSIS FOR INTERMITTENT INCIDENT"](#) .

>> INSPECTION END

Component Inspection EGR VOLUME CONTROL VALVE

UBS00P89

 With CONSULT-II

1. Turn ignition switch OFF.
2. Disconnect EGR volume control valve harness connector.

DTC P0403 EGR VOLUME CONTROL VALVE

3. Check resistance between EGR volume control valve terminal 2 and terminals 1, 3, terminal 5 and terminals 4, 6.

Resistance: 20 - 24 Ω [at 20°C (68F°)]

If NG, replace EGR volume control valve.
If OK, go to next step.

4. Remove EGR volume control valve.
5. Reconnect ECM harness connector and EGR volume control valve harness connector.
6. Turn ignition switch ON.

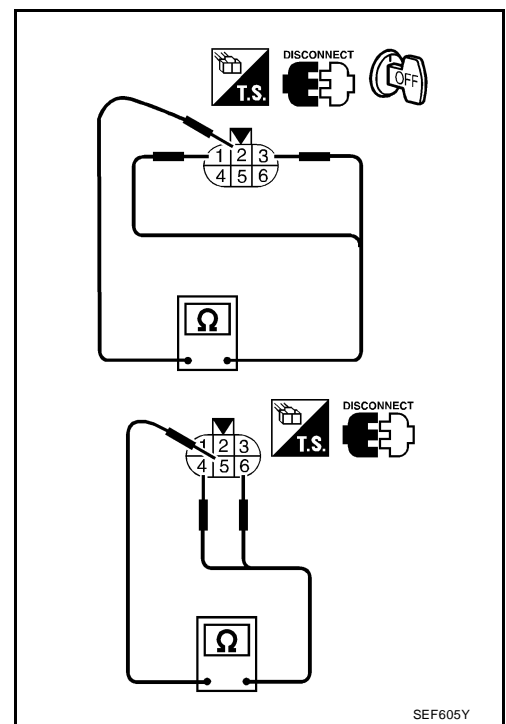

7. Perform “EGR VOL CONT/V” in “ACTIVE TEST” mode with CONSULT-II.

ACTIVE TEST	
EGR VOL CONT/V	20 step
MONITOR	
ENG SPEED	XXX rpm
EGR TEMP SEN	XXX V

SEF015Y

8. Check that EGR volume control valve shaft moves smoothly forward and backward according to the valve opening steps.
If NG, replace EGR volume control valve.

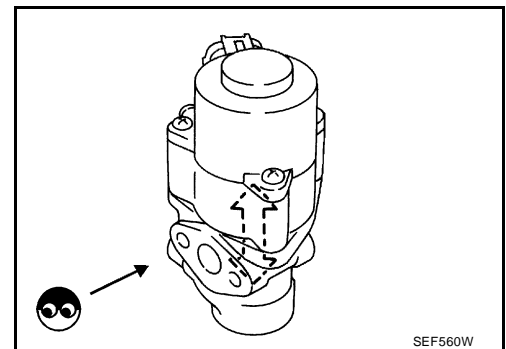

⊗ Without CONSULT-II

1. Turn ignition switch OFF.
2. Disconnect EGR volume control valve harness connector.

DTC P0403 EGR VOLUME CONTROL VALVE

3. Check resistance between EGR volume control valve terminal 2 and terminals 1, 3, terminal 5 and terminals 4, 6.

Resistance: 20 - 24 Ω [at 20°C (68F°)]

If NG, replace EGR volume control valve.
If OK, go to next step.

4. Remove EGR volume control valve.
5. Reconnect ECM harness connector and EGR volume control valve harness connector.
6. Turn ignition switch ON and OFF.

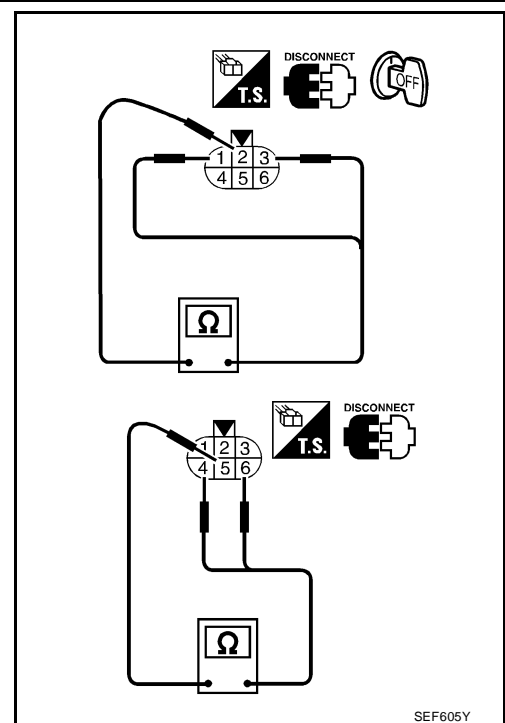

7. Check that EGR volume control valve shaft moves smoothly forward and backward according to the ignition switch position.

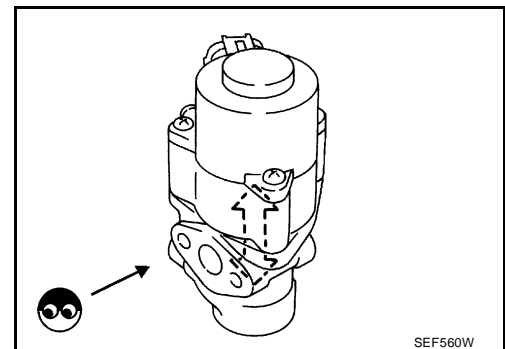

Removal and Installation EGR VOLUME CONTROL VALVE

Refer to [EM-22, "EGR VOLUME CONTROL VALVE"](#) .

DTC P0405, P0406 EGRT SENSOR

PF0:14710

DTC P0405, P0406 EGRT SENSOR

UBS00P8B

Component Description

The EGR temperature sensor detects temperature changes in the EGR passageway. When the EGR volume control valve opens, hot exhaust gases flow, and the temperature in the passageway changes. The EGR temperature sensor is a thermistor that modifies a voltage signal sent from the ECM. This modified signal then returns to the ECM as an input signal. As the temperature increases, EGR temperature sensor resistance decreases.

This sensor is not directly used to control the engine system. It is used only for the on board diagnosis.

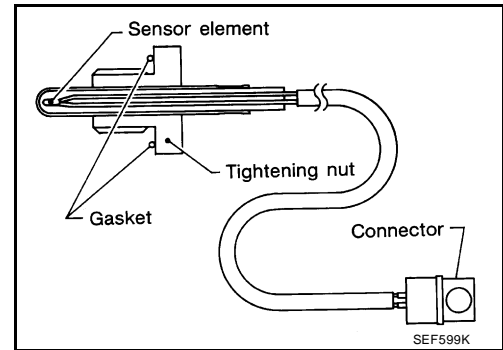

<Reference data>

EGR temperature °C (°F)	Voltage* V	Resistance MΩ
0 (32)	4.59	0.73 - 0.88
50 (122)	2.32	0.074 - 0.082
100 (212)	0.62	0.011 - 0.014

*: This data is reference value and is measured between ECM terminal 54 (EGR temperature sensor) and ground.

CAUTION:

Do not use ECM ground terminals when measuring input/output voltage. Doing so may damage the ECM's transistor. Use a ground other than ECM terminals, such as the ground.

When EGR system is operating.

Voltage: 0 - 1.5V

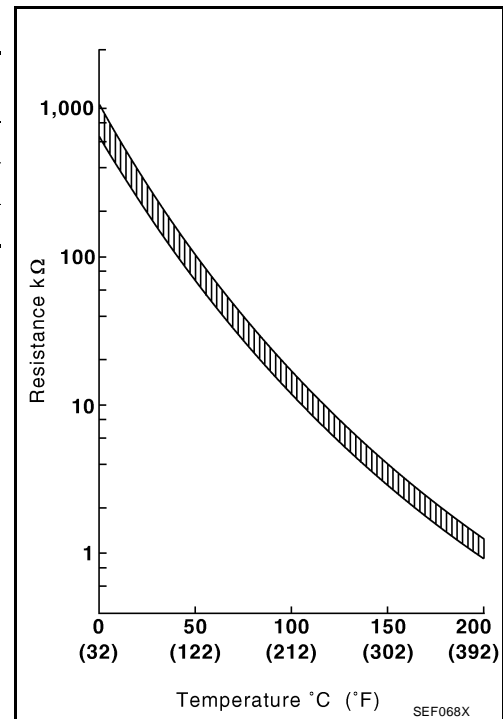

On Board Diagnosis Logic

UBS00P8C

DTC No.	Trouble Diagnosis Name	DTC Detecting Condition	Possible Cause
P0405 0405	EGR temperature sensor circuit low input	An excessively low voltage from the EGR temperature sensor is sent to ECM even when engine coolant temperature is low.	<ul style="list-style-type: none"> ● Harness or connectors (The EGR temperature sensor circuit is shorted.) ● EGR temperature sensor ● Malfunction of EGR function
P0406 0406	EGR temperature sensor circuit high input	An excessively high voltage from the EGR temperature sensor is sent to ECM even when engine coolant temperature is high.	<ul style="list-style-type: none"> ● Harness or connectors (The EGR temperature sensor circuit is open.) ● EGR temperature sensor ● Malfunction of EGR function

DTC P0405, P0406 EGRT SENSOR

UBS00P8D

DTC Confirmation Procedure

NOTE:

If DTC Confirmation Procedure has been previously conducted, always turn ignition switch OFF and wait at least 10 seconds before conducting the next test.

PROCEDURE FOR DTC P0405

With CONSULT-II

1. Turn ignition switch ON.
2. Select "DATA MONITOR" mode with CONSULT-II.
3. Verify that "COOLAN TEMP/S" indicates less than 50°C (122°F).
If the engine coolant temperature is above the range, cool the engine down.
4. Start engine and let it idle for at least 8 seconds.
5. If 1st trip DTC is detected, go to [EC-416, "Diagnostic Procedure"](#)

DATA MONITOR	
MONITOR	NO DTC
ENG SPEED	XXX rpm
COOLAN TEMP/S	XXX °C

SEF174Y

With GST

Follow the procedure "With CONSULT-II" above.

PROCEDURE FOR DTC P0406

CAUTION:

Always drive vehicle at a safe speed.

TESTING CONDITION:

Always perform the test at a temperature above -10°C (14°F).

With CONSULT-II

1. Start engine and warm it up to normal operating temperature.
2. Select "EGR VOL CONT/V" in "ACTIVE TEST" mode with CONSULT-II.
3. Hold engine speed at 1,500 rpm.
4. Touch "Qu" and set the EGR volume control valve opening to 50 step and check "EGR TEMP SEN" indication.
"EGR TEMP SEN" indication should decrease to less than 1.0V.
If the check result is NG, go to [EC-416, "Diagnostic Procedure"](#).
If the check result is OK, go to the following step.
5. Turn ignition switch OFF and wait at least 10 seconds.
6. Turn ignition switch ON and select "DATA MONITOR" mode with CONSULT-II.
7. Start engine and maintain the following conditions for at least 5 consecutive seconds.

ENG SPEED	1,200 - 2,800 rpm
VHCL SPEED SE	10 km/h (6 MPH) or more
B/FUEL SCHDL	4 - 9 msec
Shift lever	Suitable position

8. If 1st trip DTC is detected, go to [EC-416, "Diagnostic Procedure"](#)

ACTIVE TEST	
EGR VOL CONT/V	20 step
MONITOR	
ENG SPEED	XXX rpm
EGR TEMP SEN	XXX V

SEF015Y

DATA MONITOR	
MONITOR	NO DTC
ENG SPEED	XXX rpm
COOLAN TEMP/S	XXX °C
VHCL SPEED SE	XXX km/h
B/FUEL SCHDL	XXX msec

PBIB0164E

DTC P0405, P0406 EGRT SENSOR



With GST

1. Start engine and warm it up to normal operating temperature.
2. Turn ignition switch OFF, wait at least 10 seconds and then turn ON.
3. Select Service \$01 with GST and maintain the following conditions for at least 5 consecutive seconds.

Engine speed	1,200 - 2,800 rpm
Vehicle speed	10 km/h (6 MPH) or more
Shift lever	Suitable position

4. Select Service \$07 with GST.
5. If 1st trip DTC is detected, go to [EC-416, "Diagnostic Procedure"](#).

DTC P0405, P0406 EGRT SENSOR

Wiring Diagram

UBS00P8E

EC-EGR/TS-01

: DETECTABLE LINE FOR DTC
 : NON-DETECTABLE LINE FOR DTC

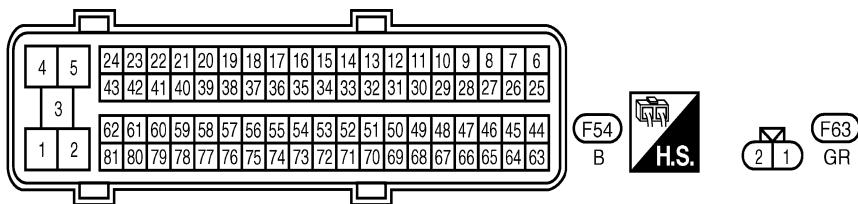
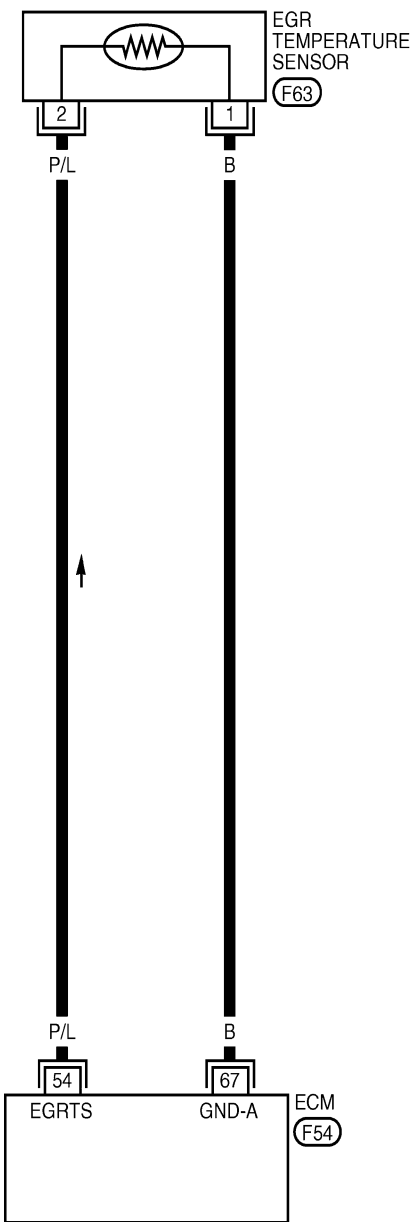

BBWA2545E

DTC P0405, P0406 EGRT SENSOR

UBS00P8F

Diagnostic Procedure

1. CHECK GROUND CONNECTIONS

1. Turn ignition switch OFF.
2. Loosen and retighten three ground screws on the body. Refer to [EC-158, "Ground Inspection"](#).

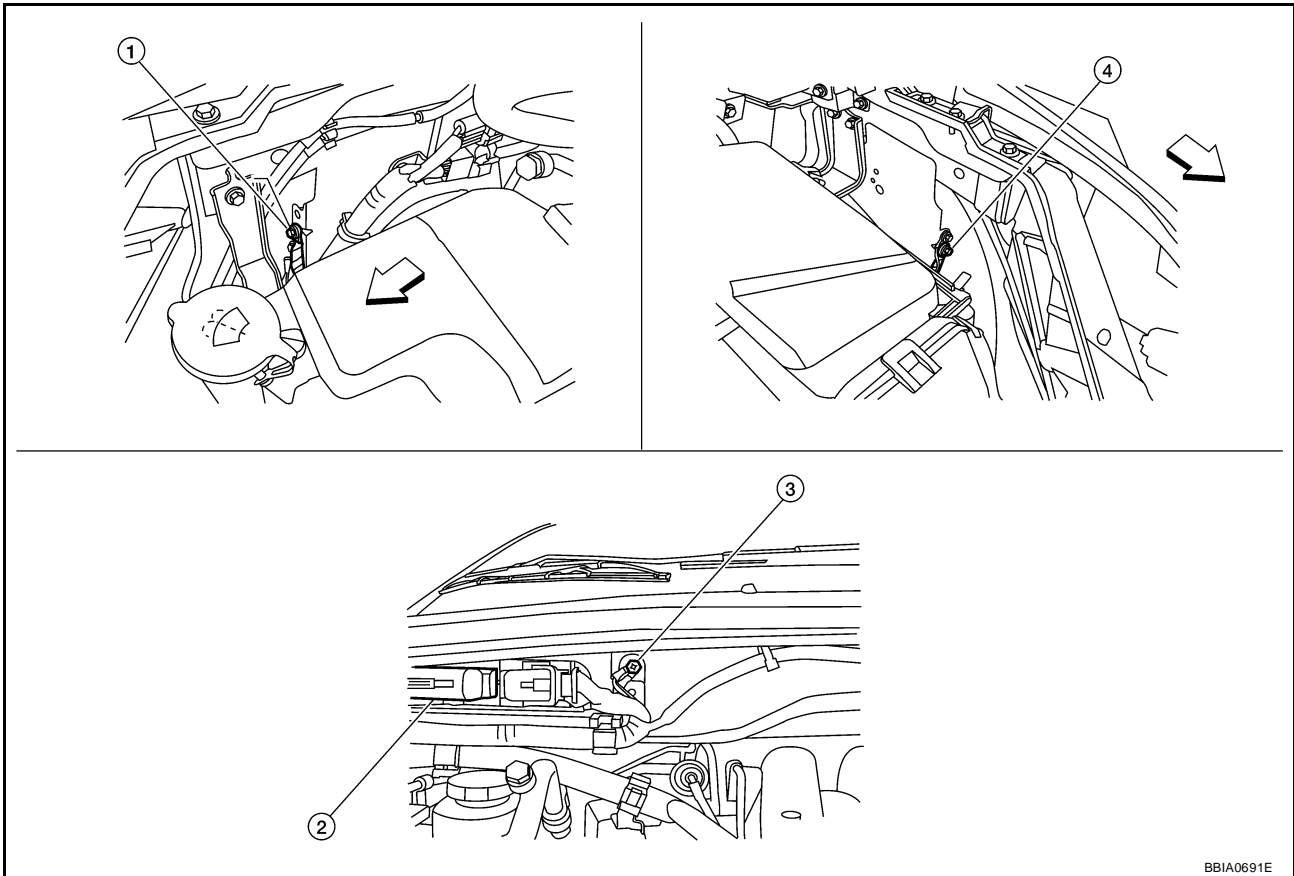

BBA0691E

← Vehicle front

1. Body ground E24

2. ECM

3. Body ground E9

4. Body ground E15

OK or NG

OK >> GO TO 2.

NG >> Repair or replace ground connections.

DTC P0405, P0406 EGRT SENSOR

2. CHECK EGR TEMPERATURE SENSOR POWER SUPPLY CIRCUIT

1. Disconnect EGR temperature sensor harness connector.
2. Turn ignition switch ON.

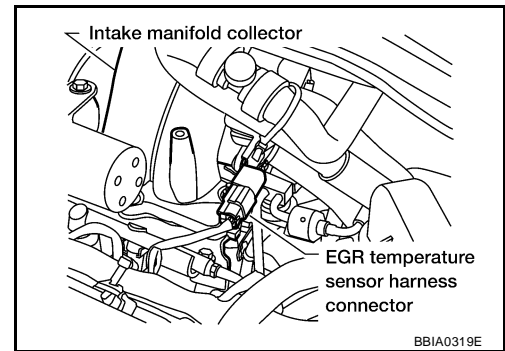

3. Check voltage between EGR temperature sensor terminal 2 and ground with CONSULT-II or tester.

Voltage: Approximately 5V

OK or NG

- OK >> GO TO 3.
NG >> Repair or replace harness or connectors.

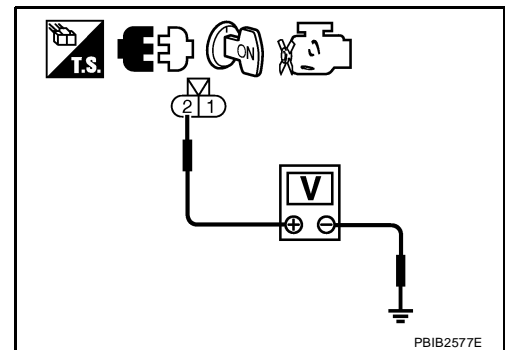

3. CHECK EGR TEMPERATURE SENSOR GROUND CIRCUIT FOR OPEN AND SHORT

1. Turn ignition switch OFF.
2. Disconnect ECM harness connector.
3. Check harness continuity between EGR temperature sensor terminal 1 and ECM terminal 67. Refer to Wiring Diagram.

Continuity should exist.

4. Also check harness for short to ground and short to power.

OK or NG

- OK >> GO TO 4.
NG >> Repair open circuit or short to ground or short to power in harness or connector.

4. CHECK EGR TEMPERATURE SENSOR

Refer to [EC-418, "Component Inspection"](#) .

OK or NG

- OK >> GO TO 5.
NG >> Replace EGR temperature sensor.

5. CHECK EGR VOLUME CONTROL VALVE

Refer to [EC-409, "Component Inspection"](#) .

OK or NG

- OK >> GO TO 6.
NG >> Replace EGR volume control valve.

DTC P0405, P0406 EGRT SENSOR

6. CHECK INTERMITTENT INCIDENT

Refer to [EC-149, "TROUBLE DIAGNOSIS FOR INTERMITTENT INCIDENT"](#) .

>> INSPECTION END

Component Inspection EGR TEMPERATURE SENSOR

UBS00P8G

1. Turn ignition switch OFF.
2. Disconnect EGR temperature sensor harness connector.
3. Check resistance between EGR temperature sensor terminals 1 and 2 as shown in the figure.

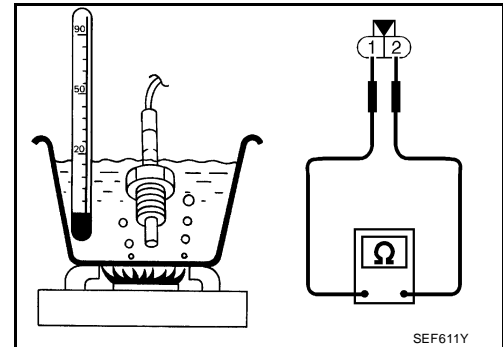

< Reference data >

EGR temperature °C (°F)	Resistance MΩ
0 (32)	0.73 - 0.88
50 (122)	0.074 - 0.082
100 (212)	0.011 - 0.014

4. If NG, replace EGR temperature sensor.

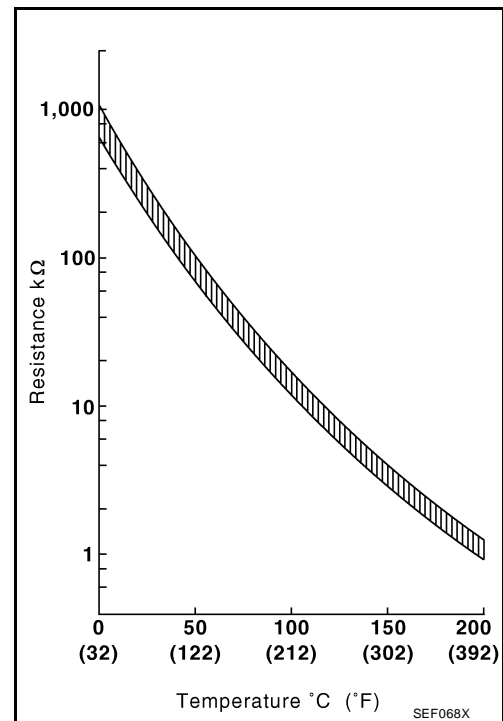

Removal and Installation EGR TEMPERATURE SENSOR

UBS00P8H

Refer to [EM-22, "EGR VOLUME CONTROL VALVE"](#) .

DTC P0420, P0430 THREE WAY CATALYST FUNCTION

DTC P0420, P0430 THREE WAY CATALYST FUNCTION

PDF:20905

On Board Diagnosis Logic

UBS00P8I

The ECM monitors the switching frequency ratio of air fuel ratio (A/F) sensor 1 and heated oxygen sensor 2.

A three way catalyst (manifold) with high oxygen storage capacity will indicate a low switching frequency of heated oxygen sensor 2. As oxygen storage capacity decreases, the heated oxygen sensor 2 switching frequency will increase.

When the frequency ratio of air fuel ratio (A/F) sensor 1 and heated oxygen sensor 2 approaches a specified limit value, the three way catalyst (manifold) malfunction is diagnosed.

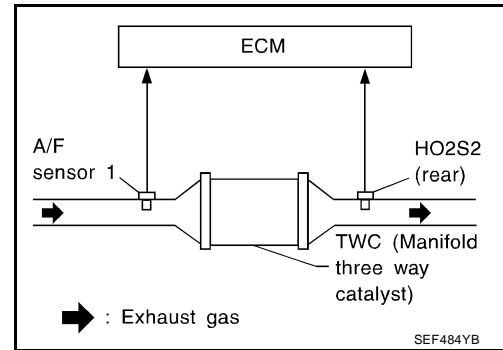

DTC No.	Trouble diagnosis name	DTC detecting condition	Possible cause
P0420 0420 (Bank 1)	Catalyst system efficiency below threshold	<ul style="list-style-type: none"> Three way catalyst (manifold) does not operate properly. Three way catalyst (manifold) does not have enough oxygen storage capacity. 	<ul style="list-style-type: none"> Three way catalyst (manifold) Exhaust tube Intake air leaks Fuel injector Fuel injector leaks Spark plug Improper ignition timing
P0430 0430 (Bank 2)			

DTC Confirmation Procedure

UBS00P8J

NOTE:

If DTC Confirmation Procedure has been previously conducted, always turn ignition switch OFF and wait at least 10 seconds before conducting the next test.

WITH CONSULT-II

TESTING CONDITION:

Do not hold engine speed for more than the specified minutes below.

- Turn ignition switch ON and select "DATA MONITOR" mode with CONSULT-II.
- Start engine and warm it up to the normal operating temperature.
- Turn ignition switch OFF and wait at least 10 seconds.
- Start engine and keep the engine speed between 3,500 and 4,000 rpm for at least 1 minute under no load.
- Let engine idle for 1 minute.
- Make sure that "COOLAN TEMP/S" indicates more than 70°C (158°F).
If not, warm up engine and go to next step when "COOLAN TEMP/S" indication reaches to 70°C (158°F).
- Open engine hood.

DATA MONITOR	
MONITOR	NO DTC
ENG SPEED	XXX rpm
COOLAN TEMP/S	XXX °C
VHCL SPEED SE	XXX km/h
B/FUEL SCHDL	XXX msec

SEF189Y

DTC P0420, P0430 THREE WAY CATALYST FUNCTION

8. Select "DTC & SRT CONFIRMATION" then "SRT WORK SUPPORT" mode with CONSULT-II.
9. Rev engine up to 2,000 to 3,000 rpm and hold it for 3 consecutive minutes then release the accelerator pedal completely. If "INCMP" of "CATALYST" changed to "CMPLT", go to step 12.
10. Wait 5 seconds at idle.

SRT WORK SUPPORT	
CATALYST	INCMP
EVAP SYSTEM	INCMP
HO2S HTR	CMPLT
HO2S	INCMP
EGR SYSTEM	INCMP
MONITOR	
ENG SPEED	XXX rpm
MAS A/F SE-B1	XXX V
B/FUEL SCHDL	XXX msec
A/F ALPHA-B1	XXX V
COOLAN TEMP/S	XX °C
A/F SEN1 (B1)	XXX V

SEF533Z

11. Rev engine up to 2,000 to 3,000 rpm and maintain it until "INCMP" of "CATALYST" changes to "CMPLT" (It will take approximately 5 minutes). If not "CMPLT", stop engine and cool it down to less than 70°C (158°F) and then retest from step 1.

SRT WORK SUPPORT	
CATALYST	CMPLT
EVAP SYSTEM	INCMP
HO2S HTR	CMPLT
HO2S	INCMP
EGR SYSTEM	INCMP
MONITOR	
ENG SPEED	XXX rpm
MAS A/F SE-B1	XXX V
B/FUEL SCHDL	XXX msec
A/F ALPHA-B1	XXX V
COOLAN TEMP/S	XX °C
A/F SEN1 (B1)	XXX V

SEF534Z

12. Select "SELF-DIAG RESULTS" mode with CONSULT-II.
13. Confirm that the 1st trip DTC is not detected. If 1st trip DTC is detected, go to [EC-421, "Diagnostic Procedure"](#)

SELF DIAG RESULTS	
DTC RESULTS	TIME
NO DTC IS DETECTED. FURTHER TESTING MAY BE REQUIRED.	

SEF535Z

Overall Function Check

UBS00P8K

Use this procedure to check the overall function of the three way catalyst (manifold). During this check, a 1st trip DTC might not be confirmed.

WITH GST

1. Start engine and warm it up to the normal operating temperature.
2. Turn ignition switch OFF and wait at least 10 seconds.
3. Start engine and keep the engine speed between 3,500 and 4,000 rpm for at least 1 minute under no load.
4. Let engine idle for 1 minute.
5. Open engine hood.
6. Set voltmeter probe between ECM terminals 74 [HO2S2 (bank 1) signal], 55 [HO2S2 (bank 2) signal] and ground.
7. Keep engine speed at 2,500 rpm constant under no load.
8. Make sure that the voltage does not vary for more than 5 seconds.

If the voltage fluctuation cycle takes less than 5 seconds, go to [EC-421, "Diagnostic Procedure"](#).

- 1 cycle: 0.6 - 1.0 → 0 - 0.3 → 0.6 - 1.0

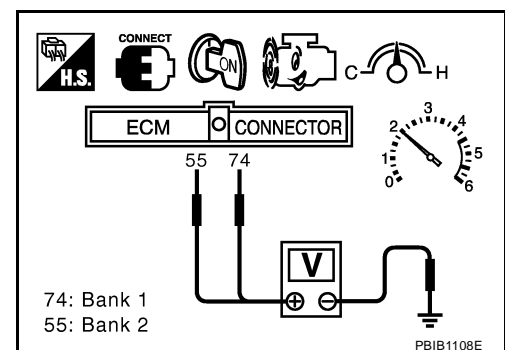

DTC P0420, P0430 THREE WAY CATALYST FUNCTION

UBS00P8L

Diagnostic Procedure

1. CHECK EXHAUST SYSTEM

Visually check exhaust tubes and muffler for dent.

OK or NG

OK >> GO TO 2.

NG >> Repair or replace.

2. CHECK EXHAUST GAS LEAK

1. Start engine and run it at idle.
2. Listen for an exhaust gas leak before the three way catalyst (manifold).

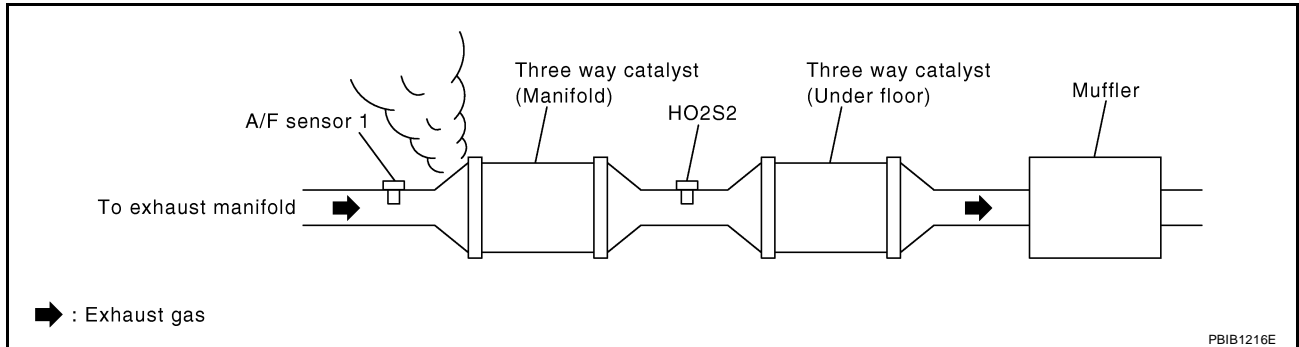

OK or NG

OK >> GO TO 3.

NG >> Repair or replace.

3. CHECK INTAKE AIR LEAK

Listen for an intake air leak after the mass air flow sensor.

OK or NG

OK >> GO TO 4.

NG >> Repair or replace.

4. CHECK IGNITION TIMING

Check the following items. Refer to [EC-73, "Basic Inspection"](#) .

Items	Specifications
Target idle speed	675 ± 50 rpm (in P or N position)
Ignition timing	15 ± 5° BTDC (in P or N position)

OK or NG

OK >> GO TO 5.

NG >> Follow the [EC-73, "Basic Inspection"](#) .

DTC P0420, P0430 THREE WAY CATALYST FUNCTION

5. CHECK FUEL INJECTORS

1. Stop engine and then turn ignition switch ON.
2. Check voltage between ECM terminals 21, 22, 23, 40, 41, 42 and ground with CONSULT-II or tester.
Refer to Wiring Diagram for FUEL INJECTOR, [EC-679](#).

Voltage: Battery voltage

OK or NG

- OK >> GO TO 6.
- NG >> Perform [EC-680, "Diagnostic Procedure"](#).

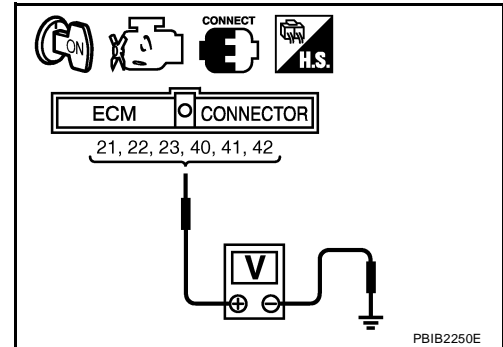

6. CHECK FUNCTION OF IGNITION COIL-I

CAUTION:

Do the following procedure in the place where ventilation is good without the combustible.

1. Turn ignition switch OFF.
2. Remove fuel pump fuse in IPDM E/R to release fuel pressure.
NOTE:
Do not use CONSULT-II to release fuel pressure, or fuel pressure applies again during the following procedure.
3. Start engine.
4. After engine stalls, crank it two or three times to release all fuel pressure.
5. Turn ignition switch OFF.
6. Remove all ignition coil harness connectors to avoid the electrical discharge from the ignition coils.
7. Remove ignition coil and spark plug of the cylinder to be checked.
8. Crank engine for 5 seconds or more to remove combustion gas in the cylinder.
9. Connect spark plug and harness connector to ignition coil.
10. Fix ignition coil using a rope etc. with gap of 13 - 17 mm between the edge of the spark plug and grounded metal portion as shown in the figure.
11. Crank engine for about 3 seconds, and check whether spark is generated between the spark plug and the grounded metal portion.

Spark should be generated.

CAUTION:

- Do not approach to the spark plug and the ignition coil within 50cm. Be careful not to get an electrical shock while checking, because the electrical discharge voltage becomes 20kV or more.
- It might cause to damage the ignition coil if the gap of more than 17 mm is taken.

NOTE:

When the gap is less than 13 mm, the spark might be generated even if the coil is malfunctioning.

OK or NG

- OK >> GO TO 10.
- NG >> GO TO 7.

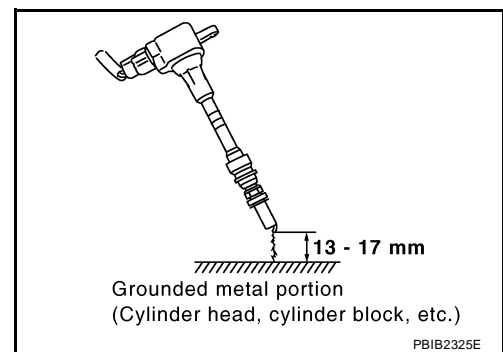
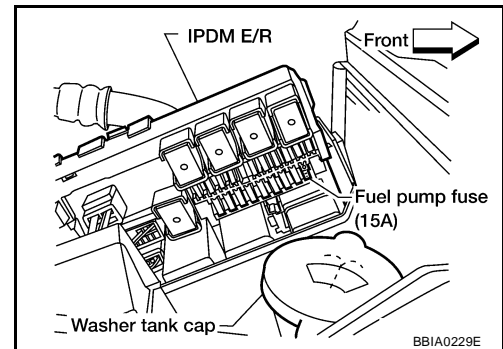

DTC P0420, P0430 THREE WAY CATALYST FUNCTION

7. CHECK FUNCTION OF IGNITION COIL-II

1. Turn ignition switch OFF.
2. Disconnect spark plug and connect a known-good spark plug.
3. Crank engine for about 3 seconds, and recheck whether spark is generated between the spark plug and the grounded metal portion.

Spark should be generated.

OK or NG

OK >> GO TO 8.

NG >> Check ignition coil, power transistor and their circuits. Refer to [EC-678, "FUEL INJECTOR"](#) .

8. CHECK SPARK PLUG

Check the initial spark plug for fouling, etc.

OK or NG

OK >> Replace spark plug(s) with standard type one(s). For spark plug type, refer to [MA-20, "Changing Spark Plugs \(Platinum - Tipped Type\)"](#) .

NG >> 1. Repair or clean spark plug.
2. GO TO 9.

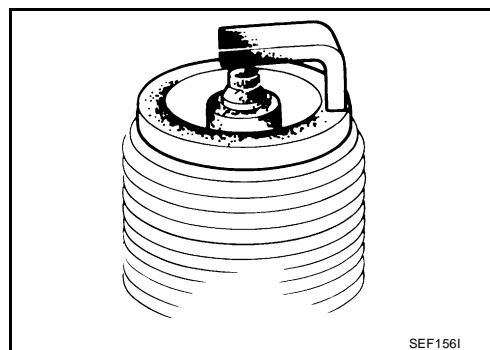

9. CHECK FUNCTION OF IGNITION COIL-III

1. Reconnect the initial spark plugs.
2. Crank engine for about 3 seconds, and recheck whether spark is generated between the spark plug and the grounded portion.

Spark should be generated.

OK or NG

OK >> **INSPECTION END**

NG >> Replace spark plug(s) with standard type one(s). For spark plug type, refer to [MA-20, "Changing Spark Plugs \(Platinum - Tipped Type\)"](#) .

10. CHECK FUEL INJECTOR

1. Turn ignition switch OFF.
2. Remove fuel injector assembly.
Refer to [EM-40, "FUEL INJECTOR AND FUEL TUBE"](#) .
Keep fuel hose and all fuel injectors connected to fuel tube.
3. Reconnect all fuel injector harness connectors.
4. Disconnect all ignition coil harness connectors.
5. Turn ignition switch ON.
Make sure fuel does not drip from fuel injector.

OK or NG

OK (Does not drip.)>>GO TO 11.

NG (Drips.)>>Replace the fuel injector(s) from which fuel is dripping.

DTC P0420, P0430 THREE WAY CATALYST FUNCTION

11. CHECK INTERMITTENT INCIDENT

Refer to [EC-149, "TROUBLE DIAGNOSIS FOR INTERMITTENT INCIDENT"](#) .

Trouble is fixed.>>**INSPECTION END**

Trouble is not fixed.>>Replace three way catalyst (manifold).

DTC P0441 EVAP CONTROL SYSTEM

DTC P0441 EVAP CONTROL SYSTEM

PF14950

System Description

UBS00P8M

NOTE:

If DTC P0441 is displayed with other DTC such as P2122, P2123, P2127, P2128 or P2138, first perform trouble diagnosis for other DTC.

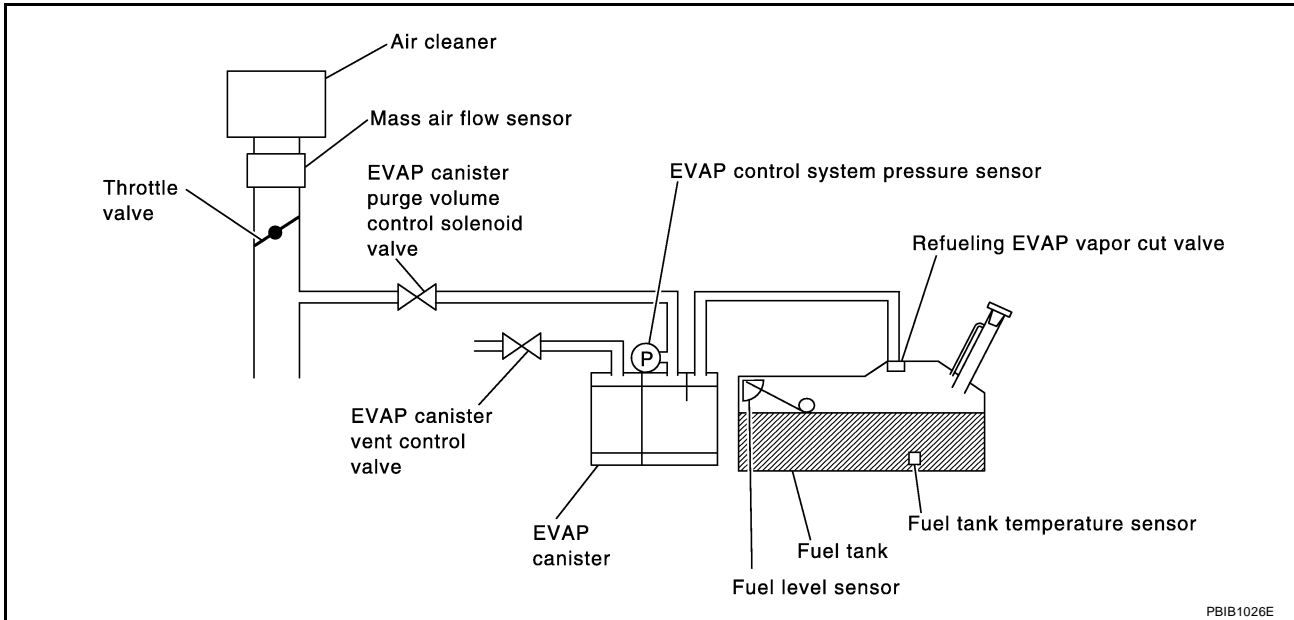

In this evaporative emission (EVAP) control system, purge flow occurs during non-closed throttle conditions. Purge volume is related to air intake volume. Under normal purge conditions (non-closed throttle), the EVAP canister purge volume control solenoid valve is open to admit purge flow. Purge flow exposes the EVAP control system pressure sensor to intake manifold vacuum.

On Board Diagnosis Logic

UBS00P8N

Under normal conditions (non-closed throttle), sensor output voltage indicates if pressure drop and purge flow are adequate. If not, a malfunction is determined.

DTC No.	Trouble diagnosis name	DTC detecting condition	Possible cause
P0441 0441	EVAP control system incorrect purge flow	EVAP control system does not operate properly, EVAP control system has a leak between intake manifold and EVAP control system pressure sensor.	<ul style="list-style-type: none"> ● EVAP canister purge volume control solenoid valve stuck closed ● EVAP control system pressure sensor and the circuit ● Loose, disconnected or improper connection of rubber tube ● Blocked rubber tube ● Cracked EVAP canister ● EVAP canister purge volume control solenoid valve circuit ● Accelerator pedal position sensor ● Blocked purge port ● EVAP canister vent control valve

DTC P0441 EVAP CONTROL SYSTEM

UBS00P80

DTC Confirmation Procedure

CAUTION:

Always drive vehicle at a safe speed.

NOTE:

If DTC Confirmation Procedure has been previously conducted, always turn ignition switch OFF and wait at least 10 seconds before conducting the next test.

TESTING CONDITION:

Always perform test at a temperature of 5°C (41°F) or more.

④ WITH CONSULT-II

1. Start engine and warm it up to normal operating temperature.
2. Turn ignition switch OFF and wait at least 10 seconds.
3. Start engine and let it idle for at least 70 seconds.
4. Select "PURG FLOW P0441" of "EVAPORATIVE SYSTEM" in "DTC CONFIRMATION" mode with CONSULT-II.
5. Touch "START".
If "COMPLETED" is displayed, go to step 7.
6. When the following conditions are met, "TESTING" will be displayed on the CONSULT-II screen. Maintain the conditions continuously until "TESTING" changes to "COMPLETED". (It will take at least 35 seconds.)

Shift lever	Suitable position
VHCL SPEED SE	32 - 120 km/h (20 - 75 MPH)
ENG SPEED	500 - 3,000 rpm
B/FUEL SCHDL	1.3 - 9.0 msec
COOLAN TEMP/S	70 - 100°C (158 - 212°F)

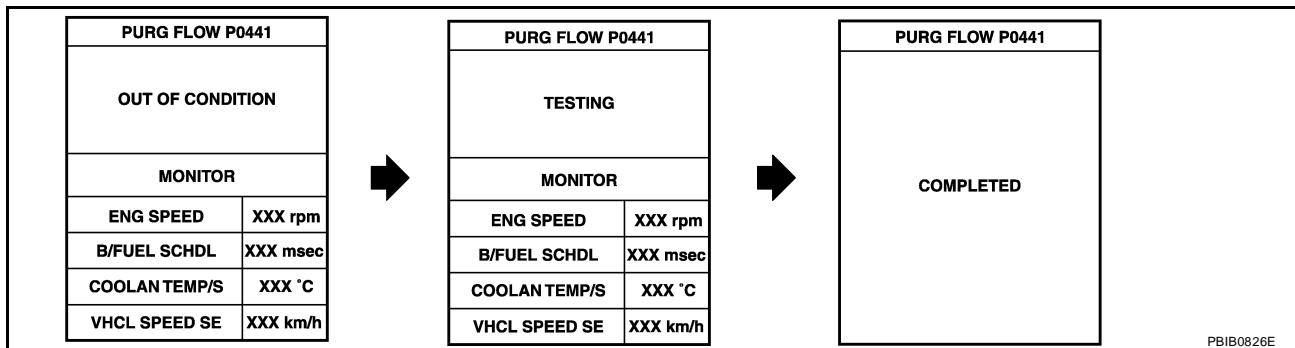

If "TESTING" is not changed for a long time, retry from step 2.

7. Make sure that "OK" is displayed after touching "SELF-DIAG RESULTS". If "NG" is displayed, refer to [EC-427, "Diagnostic Procedure"](#).

Overall Function Check

UBS00P8P

Use this procedure to check the overall monitoring function of the EVAP control system purge flow monitoring. During this check, a 1st trip DTC might not be confirmed.

④ WITH GST

1. Lift up drive wheels.
2. Start engine (TCS switch or VDC switch OFF) and warm it up to normal operating temperature.
3. Turn ignition switch OFF, wait at least 10 seconds.
4. Start engine and wait at least 70 seconds.

DTC P0441 EVAP CONTROL SYSTEM

5. Set voltmeter probes to ECM terminals 32 (EVAP control system pressure sensor signal) and ground.
6. Check EVAP control system pressure sensor value at idle speed and note it.
7. Establish and maintain the following conditions for at least 1 minute.

Air conditioner switch	ON
Headlamp switch	ON
Rear window defogger switch	ON
Engine speed	Approx. 3,000 rpm
Gear position	Any position other than P, N or R

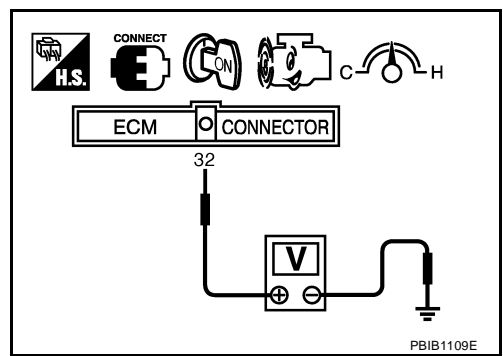

8. Verify that EVAP control system pressure sensor value stays 0.1V less than the value at idle speed (measured at step 6) for at least 1 second.
9. If NG, go to [EC-427, "Diagnostic Procedure"](#) .

Diagnostic Procedure

UBS00P8Q

1. CHECK EVAP CANISTER

1. Turn ignition switch OFF.
2. Check EVAP canister for cracks.

OK or NG

- OK (With CONSULT-II)>>GO TO 2.
- OK (Without CONSULT-II)>>GO TO 3.
- NG >> Replace EVAP canister.

2. CHECK PURGE FLOW

With CONSULT-II

1. Disconnect vacuum hose connected to EVAP canister purge volume control solenoid valve at EVAP service port and install vacuum gauge. For the location of EVAP service port, refer to [EC-33, "EVAPORATIVE EMISSION LINE DRAWING"](#) .
2. Start engine and let it idle.
3. Select "PURG VOL CONT/V" in "ACTIVE TEST" mode with CONSULT-II.
4. Rev engine up to 2,000 rpm.
5. Touch "Qd" and "Qu" on CONSULT-II screen to adjust "PURG VOL CONT/V" opening and check vacuum existence.

PURG VOL CONT/V	Vacuum
100%	Should exist
0%	Should not exist

OK or NG

- OK >> GO TO 7.
- NG >> GO TO 4.

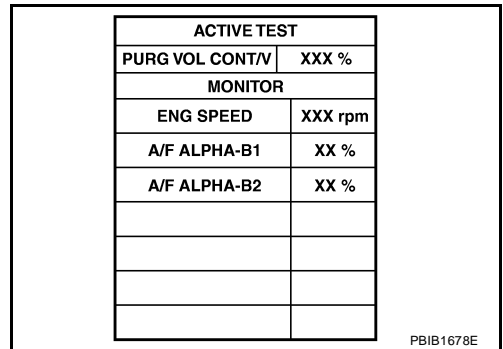

DTC P0441 EVAP CONTROL SYSTEM

3. CHECK PURGE FLOW

⊗ Without CONSULT-II

1. Start engine and warm it up to normal operating temperature.
2. Stop engine.
3. Disconnect vacuum hose connected to EVAP canister purge volume control solenoid valve at EVAP service port and install vacuum gauge. For the location of EVAP service port, refer to [EC-33, "EVAPORATIVE EMISSION LINE DRAWING"](#).
4. Start engine and let it idle.
Do not depress accelerator pedal even slightly.
5. Check vacuum gauge indication before 60 seconds passed after engine starting engine.

Vacuum should not exist.

6. Revving engine up to 2,000 rpm after 100 seconds passed after starting engine.

Vacuum should exist.

OK or NG

- OK >> GO TO 7.
NG >> GO TO 4.

4. CHECK EVAP PURGE LINE

1. Turn ignition switch OFF.
2. Check EVAP purge line for improper connection or disconnection.
Refer to [EC-33, "EVAPORATIVE EMISSION LINE DRAWING"](#).

OK or NG

- OK >> GO TO 5.
NG >> Repair it.

5. CHECK EVAP PURGE HOSE AND PURGE PORT

1. Disconnect purge hoses connected to EVAP service port **A** and EVAP canister purge volume control solenoid valve **B**.
2. Blow air into each hose and EVAP purge port **C**.

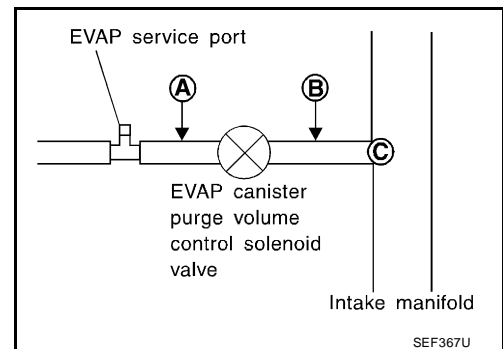

3. Check that air flows freely.

OK or NG

- OK (With CONSULT-II) >> GO TO 6.
OK (Without CONSULT-II) >> GO TO 7.
NG >> Repair or clean hoses and/or purge port.

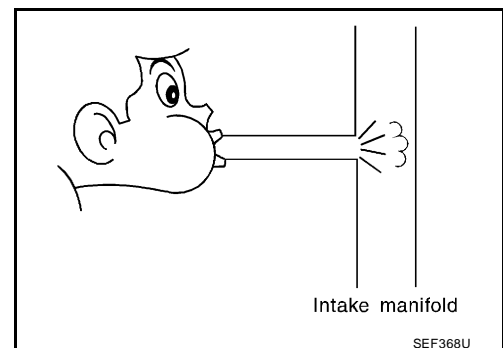

DTC P0441 EVAP CONTROL SYSTEM

6. CHECK EVAP CANISTER PURGE VOLUME CONTROL SOLENOID VALVE

With CONSULT-II

1. Start engine.
2. Perform "PURG VOL CONT/V" in "ACTIVE TEST" mode with CONSULT-II. Check that engine speed varies according to the valve opening.

OK or NG

- OK >> GO TO 8.
NG >> GO TO 7.

ACTIVE TEST	
PURG VOL CONT/V	XXX %
MONITOR	
ENG SPEED	XXX rpm
A/F ALPHA-B1	XX %
A/F ALPHA-B2	XX %

PBIB1678E

7. CHECK EVAP CANISTER PURGE VOLUME CONTROL SOLENOID VALVE

Refer to [EC-452, "Component Inspection"](#) .

OK or NG

- OK >> GO TO 8.
NG >> Replace EVAP canister purge volume control solenoid valve.

8. CHECK EVAP CONTROL SYSTEM PRESSURE SENSOR CONNECTOR

1. Disconnect EVAP control system pressure sensor harness connector.
2. Check connectors for water.

Water should not exist.

OK or NG

- OK >> GO TO 9.
NG >> Replace EVAP control system pressure sensor.

9. CHECK EVAP CONTROL SYSTEM PRESSURE SENSOR FUNCTION

Refer to DTC Confirmation Procedure for DTC P0452 [EC-473](#) , P0453 [EC-480](#) .

OK or NG

- OK >> GO TO 10.
NG >> Replace EVAP control system pressure sensor.

10. CHECK RUBBER TUBE FOR CLOGGING

1. Disconnect rubber tube connected to EVAP canister vent control valve.
2. Check the rubber tube for clogging.

OK or NG

- OK >> GO TO 11.
NG >> Clean the rubber tube using an air blower.

11. CHECK EVAP CANISTER VENT CONTROL VALVE

Refer to [EC-459, "Component Inspection"](#) .

OK or NG

- OK >> GO TO 12.
NG >> Replace EVAP canister vent control valve.

DTC P0441 EVAP CONTROL SYSTEM

12. CHECK EVAP PURGE LINE

Inspect EVAP purge line (pipe and rubber tube). Check for evidence of leaks.
Refer to [EC-33, "EVAPORATIVE EMISSION LINE DRAWING"](#) .

OK or NG

OK >> GO TO 13.
NG >> Replace it.

13. CLEAN EVAP PURGE LINE

Clean EVAP purge line (pipe and rubber tube) using air blower.

>> GO TO 14.

14. CHECK INTERMITTENT INCIDENT

Refer to [EC-149, "TROUBLE DIAGNOSIS FOR INTERMITTENT INCIDENT"](#) .

>> **INSPECTION END**

DTC P0442 EVAP CONTROL SYSTEM

DTC P0442 EVAP CONTROL SYSTEM

PF1:14950

On Board Diagnosis Logic

UBS00P8R

This diagnosis detects leaks in the EVAP purge line using engine intake manifold vacuum. If pressure does not increase, the ECM will check for leaks in the line between the fuel tank and EVAP canister purge volume control solenoid valve, under the following "Vacuum test" conditions. The EVAP canister vent control valve is closed to shut the EVAP purge line off. The EVAP canister purge volume control solenoid valve will then be opened to depressurize the EVAP purge line using intake manifold vacuum. After this occurs, the EVAP canister purge volume control solenoid valve will be closed.

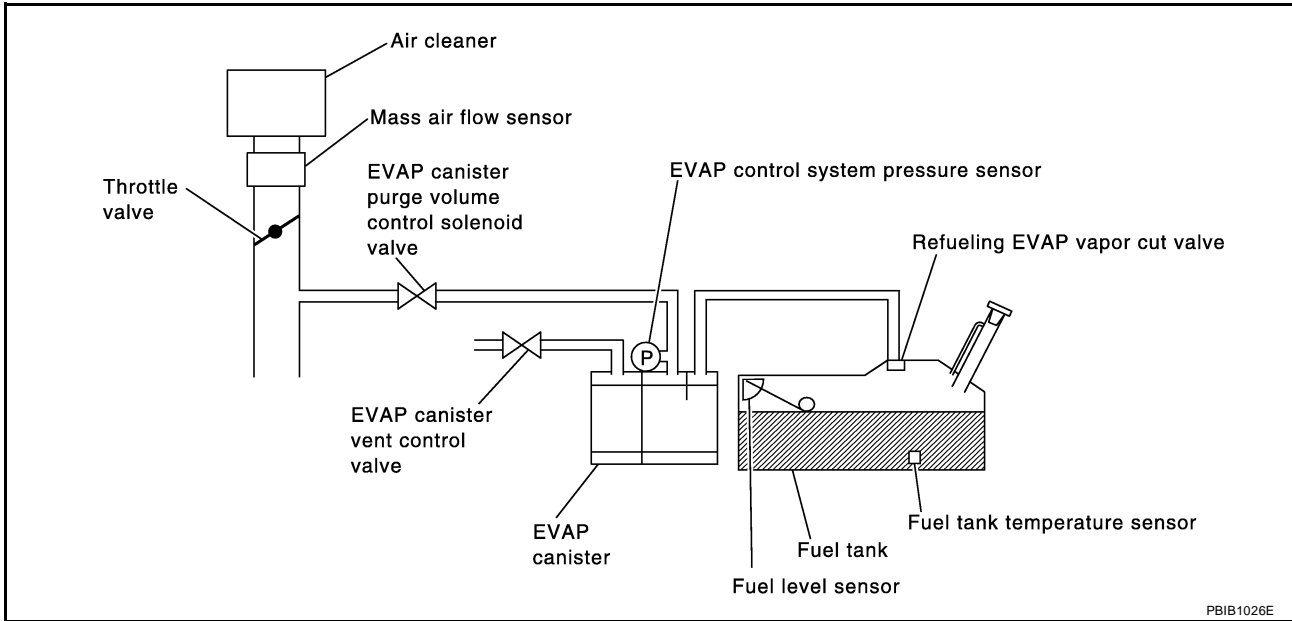

DTC No.	Trouble diagnosis name	DTC detecting condition	Possible cause
P0442 0442	EVAP control system small leak detected (negative pressure)	EVAP control system has a leak, EVAP control system does not operate properly.	<ul style="list-style-type: none"> ● Incorrect fuel tank vacuum relief valve ● Incorrect fuel filler cap used ● Fuel filler cap remains open or fails to close. ● Foreign matter caught in fuel filler cap. ● Leak is in line between intake manifold and EVAP canister purge volume control solenoid valve. ● Foreign matter caught in EVAP canister vent control valve. ● EVAP canister or fuel tank leaks ● EVAP purge line (pipe and rubber tube) leaks ● EVAP purge line rubber tube bent ● Loose or disconnected rubber tube ● EVAP canister vent control valve and the circuit ● EVAP canister purge volume control solenoid valve and the circuit ● Fuel tank temperature sensor ● O-ring of EVAP canister vent control valve is missing or damaged ● EVAP canister is saturated with water ● EVAP control system pressure sensor ● Fuel level sensor and the circuit ● Refueling EVAP vapor cut valve ● ORVR system leaks

DTC P0442 EVAP CONTROL SYSTEM

CAUTION:

- Use only a genuine NISSAN fuel filler cap as a replacement. If an incorrect fuel filler cap is used, the MIL may come on.
- If the fuel filler cap is not tightened properly, the MIL may come on.
- Use only a genuine NISSAN rubber tube as a replacement.

DTC Confirmation Procedure

UBS00P8S

NOTE:

- If DTC Confirmation Procedure has been previously conducted, always turn ignition switch OFF and wait at least 10 seconds before conducting the next test.

TESTING CONDITION:

- Perform “DTC WORK SUPPORT” when the fuel level is between 1/4 and 3/4 full, and vehicle is placed on flat level surface.
- Always perform test at a temperature of 0 to 30°C (32 to 86°F).

WITH CONSULT-II

1. Turn ignition switch ON.
2. Turn ignition switch OFF and wait at least 10 seconds.
3. Turn ignition switch ON and select “DATA MONITOR” mode with CONSULT-II.
4. Make sure that the following conditions are met.
COOLANT TEMP/S: 0 - 70°C (32 - 158°F)
INT/A TEMP SE: 0 - 30°C (32 - 86°F)
5. Select “EVAP SML LEAK P0442/P1442” of “EVAPORATIVE SYSTEM” in “DTC WORK SUPPORT” mode with CONSULT-II.
Follow the instruction displayed.

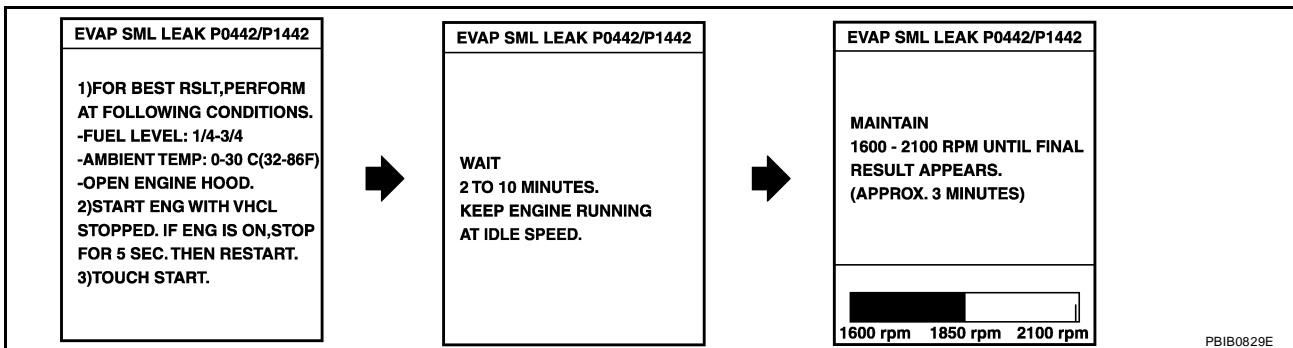

NOTE:

If the engine speed cannot be maintained within the range displayed on the CONSULT-II screen, go to [EC-73, "Basic Inspection"](#).

6. Make sure that “OK” is displayed.
If “NG” is displayed, refer to [EC-433, "Diagnostic Procedure"](#).

NOTE:

Make sure that EVAP hoses are connected to EVAP canister purge volume control solenoid valve properly.

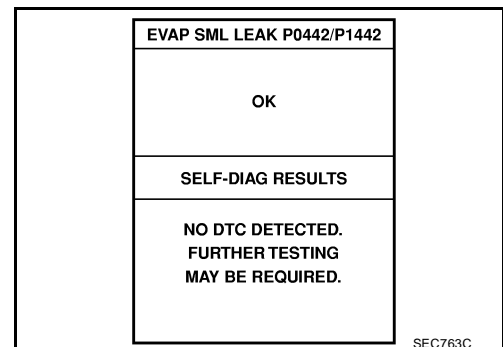

DTC P0442 EVAP CONTROL SYSTEM

WITH GST

NOTE:

Be sure to read the explanation of Driving Pattern on [EC-59, "Driving Pattern"](#) before driving vehicle.

1. Start engine.
2. Drive vehicle according to Driving Pattern, [EC-59, "Driving Pattern"](#) .
3. Stop vehicle.
4. Turn ignition switch OFF, wait at least 10 seconds and then turn ON.
5. Select Service \$07 with GST.
 - If P0442 is displayed on the screen, go to [EC-433, "Diagnostic Procedure"](#) .
 - If P0441 is displayed on the screen, go to Diagnostic Procedure for DTC P0441, [EC-427](#) .

Diagnostic Procedure

UBS00P8T

1. CHECK FUEL FILLER CAP DESIGN

1. Turn ignition switch OFF.
2. Check for genuine NISSAN fuel filler cap design.

OK or NG

- OK >> GO TO 2.
NG >> Replace with genuine NISSAN fuel filler cap.

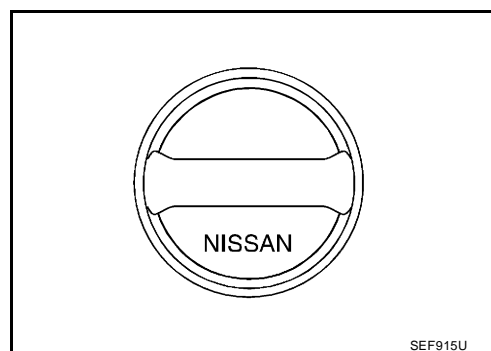

2. CHECK FUEL FILLER CAP INSTALLATION

Check that the cap is tightened properly by rotating the cap clockwise.

OK or NG

- OK >> GO TO 3.
NG >> 1. Open fuel filler cap, then clean cap and fuel filler neck threads using air blower.
2. Retighten until ratcheting sound is heard.

3. CHECK FUEL FILLER CAP FUNCTION

Check for air releasing sound while opening the fuel filler cap.

OK or NG

- OK >> GO TO 5.
NG >> GO TO 4.

4. CHECK FUEL TANK VACUUM RELIEF VALVE

Refer to [EC-35, "FUEL TANK VACUUM RELIEF VALVE \(BUILT INTO FUEL FILLER CAP\)"](#) .

OK or NG

- OK >> GO TO 5.
NG >> Replace fuel filler cap with a genuine one.

DTC P0442 EVAP CONTROL SYSTEM

5. INSTALL THE PRESSURE PUMP

To locate the EVAP leak, install EVAP service port adapter and pressure pump to EVAP service port securely.

NOTE:

Improper installation of the EVAP service port adapter to the EVAP service port may cause leaking.

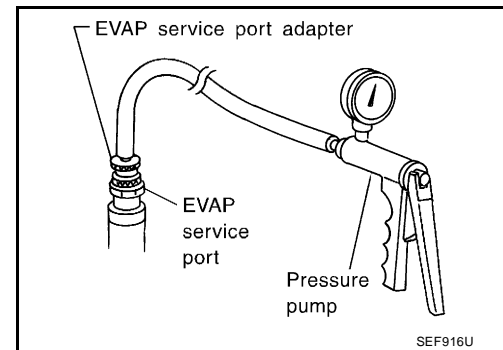
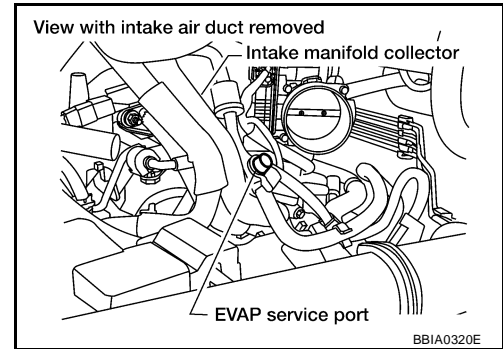

With CONSULT-II>>GO TO 6.
Without CONSULT-II>>GO TO 7.

6. CHECK FOR EVAP LEAK

With CONSULT-II

1. Turn ignition switch ON.
2. Select "EVAP SYSTEM CLOSE" of "WORK SUPPORT" mode with CONSULT-II.
3. Touch "START" and apply pressure into the EVAP line until the pressure indicator reaches the middle of the bar graph.

CAUTION:

- Never use compressed air or a high pressure pump.
- Do not exceed 4.12 kPa (0.042 kg/cm² , 0.6 psi) of pressure in the system.

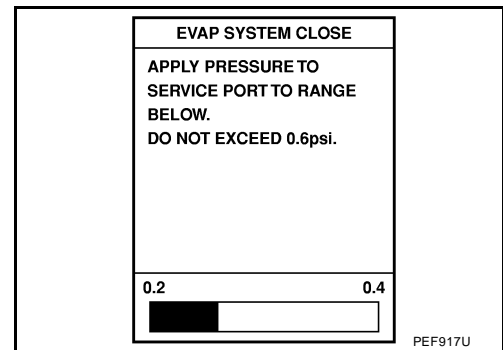

4. Using EVAP leak detector, locate the EVAP leak. For the leak detector, refer to the instruction manual for more details.
Refer to [EC-33, "EVAPORATIVE EMISSION LINE DRAWING"](#) .

OK or NG

- OK >> GO TO 8.
NG >> Repair or replace.

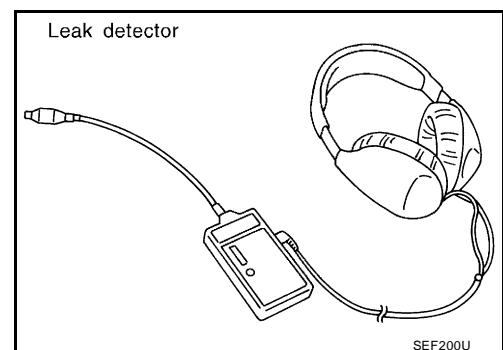

DTC P0442 EVAP CONTROL SYSTEM

7. CHECK FOR EVAP LEAK

⊗ Without CONSULT-II

1. Turn ignition switch OFF.
2. Apply 12 volts DC to EVAP canister vent control valve. The valve will close. (Continue to apply 12 volts until the end of test.)

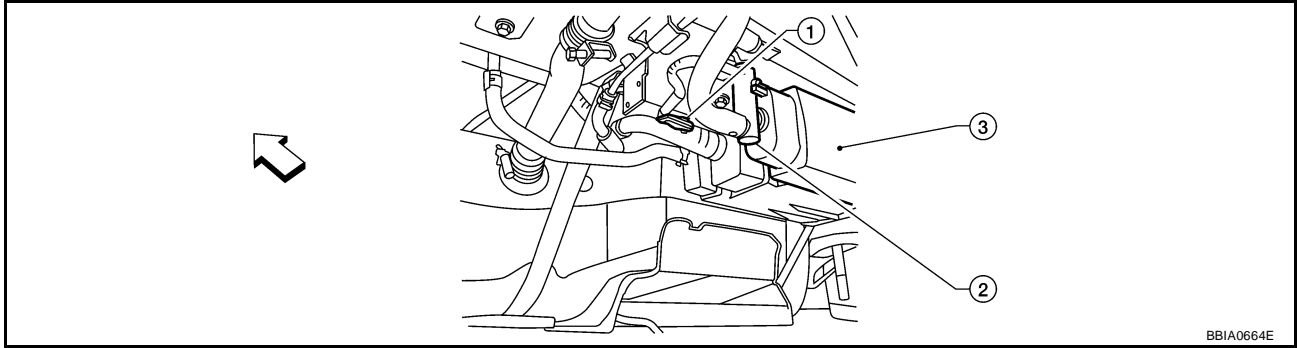

← Vehicle front

1. EVAP control system pressure sensor 2. EVAP canister vent control valve 3. EVAP canister
3. Pressurize the EVAP line using pressure pump with 1.3 to 2.7 kPa (10 to 20 mmHg, 0.39 to 0.79 inHg), then remove pump and EVAP service port adapter.

CAUTION:

- Never use compressed air or a high pressure pump.
 - Do not exceed 4.12 kPa (0.042 kg/cm², 0.6 psi) of pressure in the system.
4. Using EVAP leak detector, locate the EVAP leak. For the leak detector, refer to the instruction manual for more details. Refer to [EC-33, "EVAPORATIVE EMISSION LINE DRAWING"](#).

OK or NG

- OK >> GO TO 8.
NG >> Repair or replace.

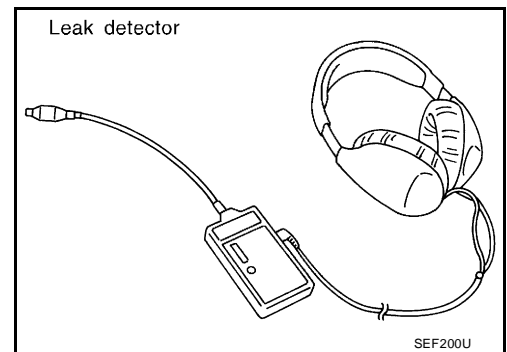

8. CHECK EVAP CANISTER VENT CONTROL VALVE

Check the following.

- EVAP canister vent control valve is installed properly. Refer to [EC-36, "Removal and Installation"](#).
- EVAP canister vent control valve. Refer to [EC-459, "Component Inspection"](#).

OK or NG

- OK >> GO TO 9.
NG >> Repair or replace EVAP canister vent control valve and O-ring.

DTC P0442 EVAP CONTROL SYSTEM

9. CHECK IF EVAP CANISTER SATURATED WITH WATER

1. Remove EVAP canister with EVAP canister vent control valve and EVAP control system pressure sensor attached.
2. Does water drain from the EVAP canister?

Yes or No

Yes >> GO TO 10.

No (With CONSULT-II)>>GO TO 12.

No (Without CONSULT-II)>>GO TO 13.

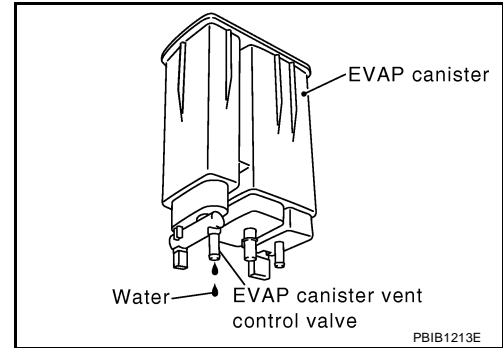

10. CHECK EVAP CANISTER

Weigh the EVAP canister with the EVAP canister vent control valve and EVAP control system pressure sensor attached.

The weight should be less than 2.1 kg (4.6 lb).

OK or NG

OK (With CONSULT-II)>>GO TO 12.

OK (Without CONSULT-II)>>GO TO 13.

NG >> GO TO 11.

11. DETECT MALFUNCTIONING PART

Check the following.

- EVAP canister for damage
- EVAP hose between EVAP canister and vehicle frame for clogging or poor connection

>> Repair hose or replace EVAP canister.

12. CHECK EVAP CANISTER PURGE VOLUME CONTROL SOLENOID VALVE OPERATION

Ⓟ With CONSULT-II

1. Disconnect vacuum hose to EVAP canister purge volume control solenoid valve at EVAP service port.
2. Start engine.
3. Perform "PURG VOL CONT/V" in "ACTIVE TEST" mode.
4. Touch "Qu" on CONSULT-II screen to increase "PURG VOL CONT/V" opening to 100%.
5. Check vacuum hose for vacuum when revving engine up to 2,000 rpm.

OK or NG

OK >> GO TO 15.

NG >> GO TO 14.

The screenshot shows a digital display with a table of test parameters. The table has two columns and several rows. The first row is the title 'ACTIVE TEST'. The second row shows 'PURG VOL CONT/V' and 'XXX %'. The third row is the title 'MONITOR'. The fourth row shows 'ENG SPEED' and 'XXX rpm'. The fifth row shows 'A/F ALPHA-B1' and 'XX %'. The sixth row shows 'A/F ALPHA-B2' and 'XX %'. There are three empty rows below. The screenshot is enclosed in a rectangular box with the reference code 'PBIB1678E' in the bottom right corner.

ACTIVE TEST	
PURG VOL CONT/V	XXX %
MONITOR	
ENG SPEED	XXX rpm
A/F ALPHA-B1	XX %
A/F ALPHA-B2	XX %

DTC P0442 EVAP CONTROL SYSTEM

13. CHECK EVAP CANISTER PURGE VOLUME CONTROL SOLENOID VALVE OPERATION

Without CONSULT-II

1. Start engine and warm it up to normal operating temperature.
2. Stop engine.
3. Disconnect vacuum hose to EVAP canister purge volume control solenoid valve at EVAP service port.
4. Start engine and let it idle for at least 80 seconds.
5. Check vacuum hose for vacuum when revving engine up to 2,000 rpm.

Vacuum should exist.

OK or NG

- OK >> GO TO 16.
NG >> GO TO 14.

14. CHECK VACUUM HOSE

Check vacuum hoses for clogging or disconnection. Refer to [EC-106, "Vacuum Hose Drawing"](#).

OK or NG

- OK >> GO TO 15.
NG >> Repair or reconnect the hose.

15. CHECK EVAP CANISTER PURGE VOLUME CONTROL SOLENOID VALVE

Refer to [EC-452, "Component Inspection"](#).

OK or NG

- OK >> GO TO 16.
NG >> Replace EVAP canister purge volume control solenoid valve.

16. CHECK FUEL TANK TEMPERATURE SENSOR

Refer to [EC-351, "Component Inspection"](#).

OK or NG

- OK >> GO TO 17.
NG >> Replace fuel level sensor unit.

17. CHECK EVAP CONTROL SYSTEM PRESSURE SENSOR

Refer to [EC-478, "Component Inspection"](#).

OK or NG

- OK >> GO TO 18.
NG >> Replace EVAP control system pressure sensor.

18. CHECK EVAP PURGE LINE

Check EVAP purge line (pipe, rubber tube, fuel tank and EVAP canister) for cracks or improper connection. Refer to [EC-33, "EVAPORATIVE EMISSION LINE DRAWING"](#).

OK or NG

- OK >> GO TO 19.
NG >> Repair or reconnect the hose.

19. CLEAN EVAP PURGE LINE

Clean EVAP purge line (pipe and rubber tube) using air blower.

>> GO TO 20.

DTC P0442 EVAP CONTROL SYSTEM

20. CHECK EVAP/ORVR LINE

Check EVAP/ORVR line between EVAP canister and fuel tank for clogging, kink, looseness and improper connection. For location, refer to [EC-39, "ON BOARD REFUELING VAPOR RECOVERY \(ORVR\)"](#) .

OK or NG

- OK >> GO TO 21.
- NG >> Repair or replace hoses and tubes.

21. CHECK RECIRCULATION LINE

Check recirculation line between filler neck tube and fuel tank for clogging, kink, cracks, looseness and improper connection.

OK or NG

- OK >> GO TO 22.
- NG >> Repair or replace hose, tube or filler neck tube.

22. CHECK REFUELING EVAP VAPOR CUT VALVE

Refer to [EC-43, "Component Inspection"](#) .

OK or NG

- OK >> GO TO 23.
- NG >> Replace refueling EVAP vapor cut valve with fuel tank.

23. CHECK FUEL LEVEL SENSOR

Refer to [FL-5, "FUEL LEVEL SENSOR UNIT, FUEL FILTER AND FUEL PUMP ASSEMBLY"](#) .

OK or NG

- OK >> GO TO 24.
- NG >> Replace fuel level sensor unit.

24. CHECK INTERMITTENT INCIDENT

Refer to [EC-149, "TROUBLE DIAGNOSIS FOR INTERMITTENT INCIDENT"](#) .

>> INSPECTION END

DTC P0443 EVAP CANISTER PURGE VOLUME CONTROL SOLENOID VALVE

DTC P0443 EVAP CANISTER PURGE VOLUME CONTROL SOLENOID VALVE

PFP:14920

UBS00P8U

Description SYSTEM DESCRIPTION

Sensor	Input Signal to ECM	ECM function	Actuator
Crankshaft position sensor (POS) Camshaft position sensor (PHASE)	Engine speed*1	EVAP canister purge flow control	EVAP canister purge vol- ume control solenoid valve
Mass air flow sensor	Amount of intake air		
Engine coolant temperature sensor	Engine coolant temperature		
Battery	Battery voltage*1		
Throttle position sensor	Throttle position		
Accelerator pedal position sensor	Accelerator pedal position		
Air fuel ratio (A/F) sensors 1	Density of oxygen in exhaust gas (Mixture ratio feedback signal)		
Fuel tank temperature sensor	Fuel temperature in fuel tank		
Wheel sensor	Vehicle speed*2		

*1: ECM determines the start signal status by the signals of engine speed and battery voltage.

*2: This signal is sent to the ECM through CAN communication line.

This system controls flow rate of fuel vapor from the EVAP canister. The opening of the vapor by-pass passage in the EVAP canister purge volume control solenoid valve changes to control the flow rate. The EVAP canister purge volume control solenoid valve repeats ON/OFF operation according to the signal sent from the ECM. The opening of the valve varies for optimum engine control. The optimum value stored in the ECM is determined by considering various engine conditions. When the engine is operating, the flow rate of fuel vapor from the EVAP canister is regulated as the air flow changes.

COMPONENT DESCRIPTION

The EVAP canister purge volume control solenoid valve uses a ON/OFF duty to control the flow rate of fuel vapor from the EVAP canister. The EVAP canister purge volume control solenoid valve is moved by ON/OFF pulses from the ECM. The longer the ON pulse, the greater the amount of fuel vapor that will flow through the valve.

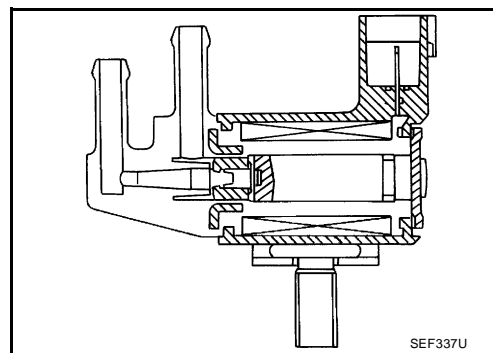

CONSULT-II Reference Value in Data Monitor Mode

UBS00P8V

Specification data are reference values.

MONITOR ITEM	CONDITION		SPECIFICATION
PURG VOL C/V	<ul style="list-style-type: none"> ● Engine: After warming up ● Shift lever: P or N ● Air conditioner switch: OFF ● No load 	Idle (Accelerator pedal is not depressed even slightly, after engine starting)	0%
		2,000 rpm	—

DTC P0443 EVAP CANISTER PURGE VOLUME CONTROL SOLENOID VALVE

On Board Diagnosis Logic

UBS00P8W

DTC No.	Trouble diagnosis name	DTC detecting condition	Possible cause
P0443 0443	EVAP canister purge volume control solenoid valve	The canister purge flow is detected during the specified driving conditions, even when EVAP canister purge volume control solenoid valve is completely closed.	<ul style="list-style-type: none"> ● EVAP control system pressure sensor ● EVAP canister purge volume control solenoid valve (The valve is stuck open.) ● EVAP canister vent control valve ● EVAP canister ● Hoses (Hoses are connected incorrectly or clogged.)

DTC Confirmation Procedure

UBS00P8X

NOTE:

If DTC Confirmation Procedure has been previously conducted, always turn ignition switch OFF and wait at least 10 seconds before conducting the next test.

TESTING CONDITION:

Always perform test at a temperature of 5°C (41°F) or more.

WITH CONSULT-II

1. Start engine and warm it up to normal operating temperature.
2. Turn ignition switch OFF and wait at least 10 seconds.
3. Turn ignition switch ON.
4. Select "PURG VOL CN/V P1444" of "EVAPORATIVE SYSTEM" in "DTC WORK SUPPORT" mode with CONSULT-II.
5. Touch "START".

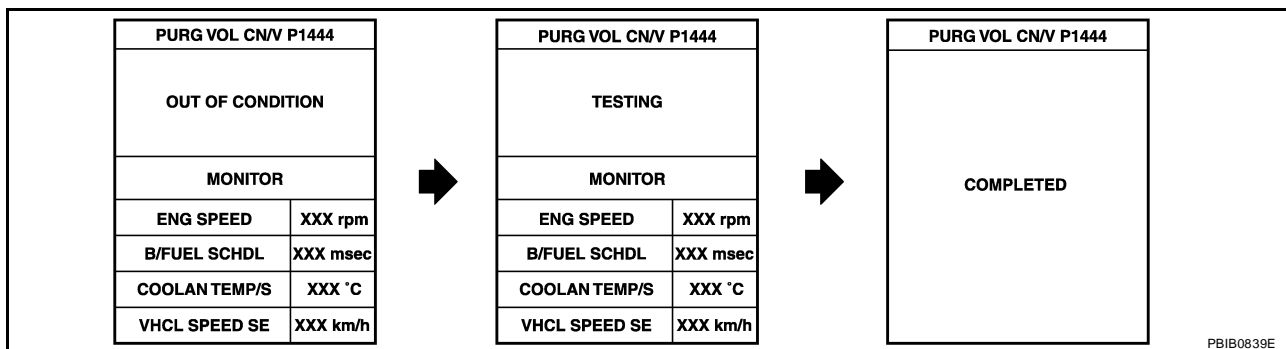

6. Start engine and let it idle until "TESTING" on CONSULT-II changes to "COMPLETED". (It will take approximately 10 seconds.)
If "TESTING" is not displayed after 5 minutes, retry from step 2.
7. Make sure that "OK" is displayed after touching "SELF-DIAG RESULTS". If "NG" is displayed, refer to [EC-443, "Diagnostic Procedure"](#).

WITH GST

1. Start engine and warm it up to normal operating temperature.
2. Turn ignition switch OFF and wait at least 10 seconds.
3. Start engine and let it idle for at least 20 seconds.
4. Select Service \$07 with GST.
5. If 1st trip DTC is detected, go to [EC-443, "Diagnostic Procedure"](#).

DTC P0443 EVAP CANISTER PURGE VOLUME CONTROL SOLENOID VALVE

Wiring Diagram

UBS00P8Y

EC-PGC/V-01

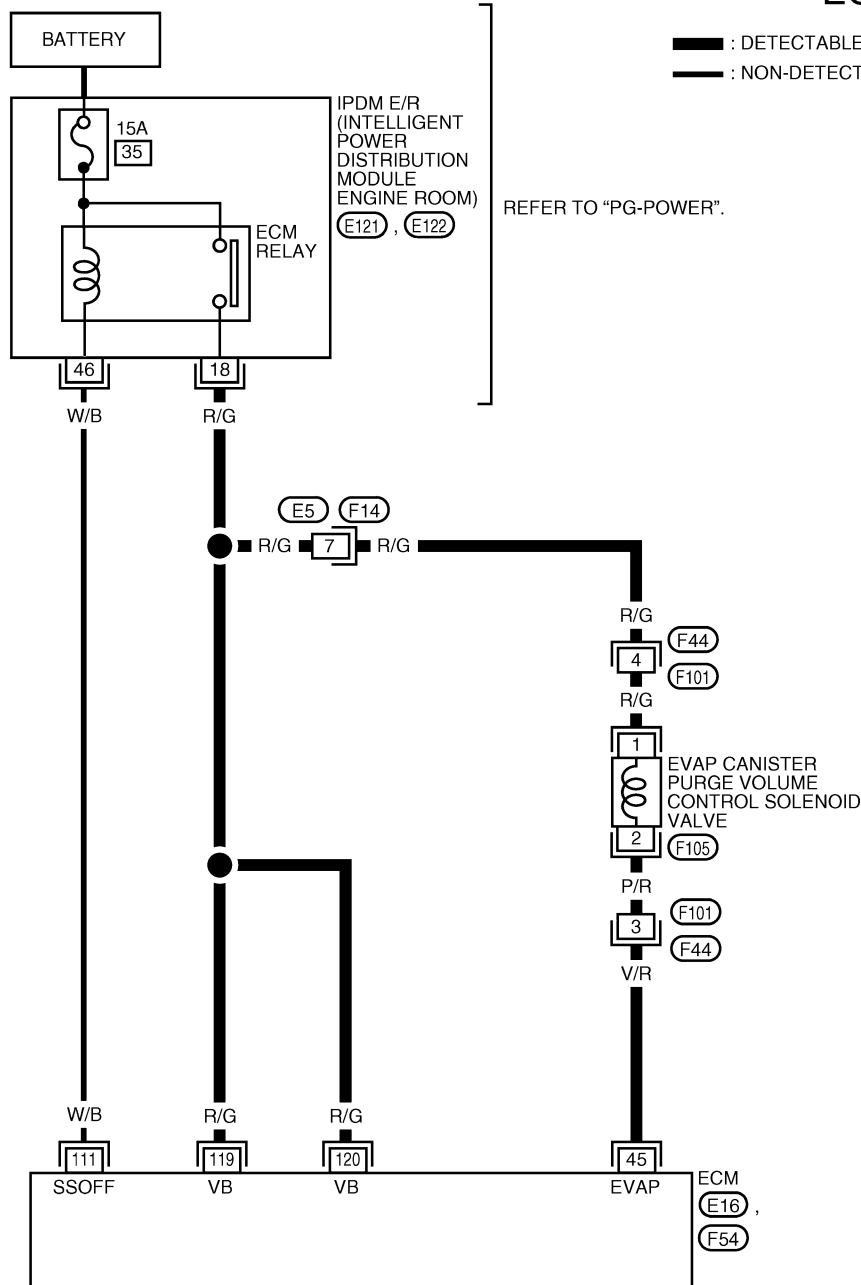

A
 EC
 C
 D
 E
 F
 G
 H
 I
 J
 K
 L
 M

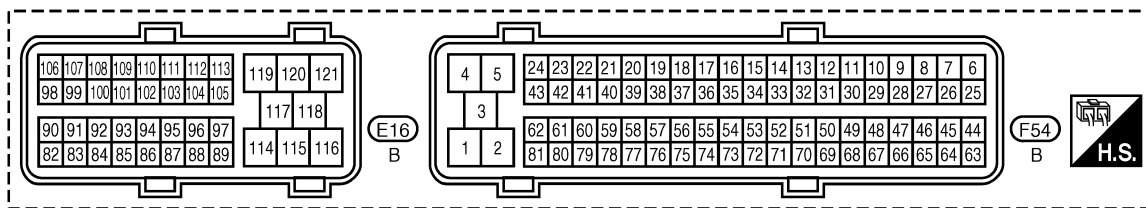

BBWA2517E

DTC P0443 EVAP CANISTER PURGE VOLUME CONTROL SOLENOID VALVE

Specification data are reference values and are measured between each terminal and ground.
Pulse signal is measured by CONSULT-II.

CAUTION:

Do not use ECM ground terminals when measuring input/output voltage. Doing so may result in damage to the ECM's transistor. Use a ground other than ECM terminals, such as the ground.

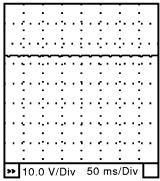
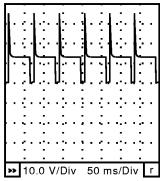
TER-MINAL NO.	WIRE COLOR	ITEM	CONDITION	DATA (DC Voltage)
45	V/R	EVAP canister purge volume control solenoid valve	<p>[Engine is running]</p> <ul style="list-style-type: none"> ● Idle speed ● Accelerator pedal: Not depressed even slightly, after engine starting 	<p>BATTERY VOLTAGE (11 - 14V)★</p>  <p>SEC990C</p>
			<p>[Engine is running]</p> <ul style="list-style-type: none"> ● Engine speed: About 2,000 rpm (More than 100 seconds after starting engine) 	<p>BATTERY VOLTAGE (11 - 14V)★</p>  <p>SEC991C</p>
111	W/B	ECM relay (Self shut-off)	<p>[Engine is running] [Ignition switch: OFF]</p> <ul style="list-style-type: none"> ● For a few seconds after turning ignition switch OFF 	0 - 1.5V
			<p>[Ignition switch: OFF]</p> <ul style="list-style-type: none"> ● More than a few seconds after turning ignition switch OFF 	BATTERY VOLTAGE (11 - 14V)
119 120	R/G R/G	Power supply for ECM	[Ignition switch: ON]	BATTERY VOLTAGE (11 - 14V)

★: Average voltage for pulse signal (Actual pulse signal can be confirmed by oscilloscope.)

DTC P0443 EVAP CANISTER PURGE VOLUME CONTROL SOLENOID VALVE

UBS00P8Z

Diagnostic Procedure

1. CHECK EVAP CANISTER PURGE VOLUME CONTROL SOLENOID VALVE POWER SUPPLY CIRCUIT

1. Turn ignition switch OFF.
2. Disconnect EVAP canister purge volume control solenoid valve harness connector.
3. Turn ignition switch ON.

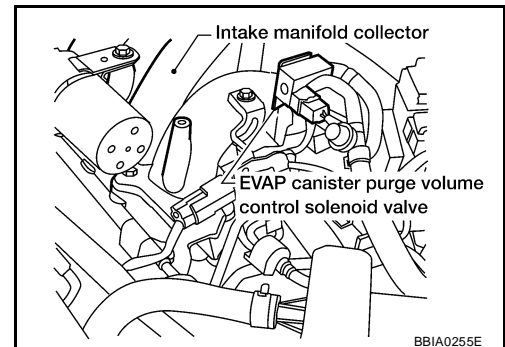

4. Check voltage between EVAP canister purge volume control solenoid valve terminal 1 and ground with CONSULT-II or tester.

Voltage: Battery voltage

OK or NG

- OK >> GO TO 3.
- NG >> GO TO 2.

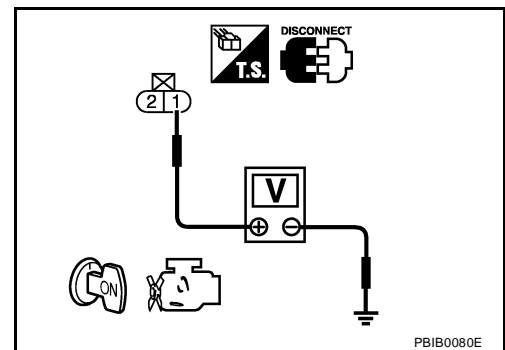

2. DETECT MALFUNCTIONING PART

Check the following.

- Harness connectors E5, F14
- Harness connectors F44, F101
- Harness for open or short between EVAP canister purge volume control solenoid valve and IPDM E/R
- Harness for open or short between EVAP canister purge volume control solenoid valve and ECM

>> Repair harness or connectors.

3. CHECK EVAP CANISTER PURGE VOLUME CONTROL SOLENOID VALVE OUTPUT SIGNAL CIRCUIT FOR OPEN AND SHORT

1. Turn ignition switch OFF.
2. Disconnect ECM harness connector.
3. Check harness continuity between ECM terminal 45 and EVAP canister purge volume control solenoid valve terminal 2. Refer to Wiring Diagram.

Continuity should exist.

4. Also check harness for short to ground and short to power.

OK or NG

- OK >> GO TO 5.
- NG >> GO TO 4.

DTC P0443 EVAP CANISTER PURGE VOLUME CONTROL SOLENOID VALVE

4. DETECT MALFUNCTIONING PART

Check the following.

- Harness connectors F44, F101
- Harness for open or short between EVAP canister purge volume control solenoid valve and ECM

>> Repair open circuit or short to ground or short to power in harness or connectors.

5. CHECK EVAP CONTROL SYSTEM PRESSURE SENSOR CONNECTOR

1. Disconnect EVAP control system pressure sensor harness connector.

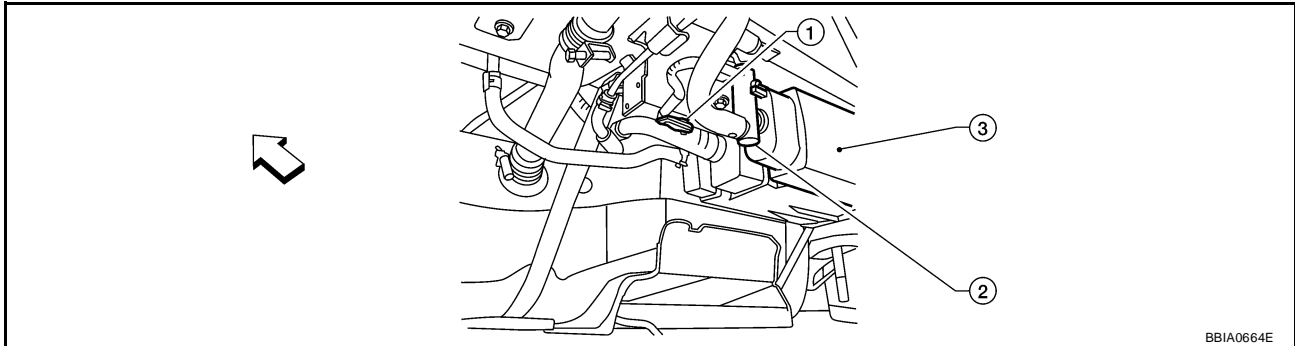

← Vehicle front

1. EVAP control system pressure sensor 2. EVAP canister vent control valve 3. EVAP canister

2. Check connectors for water.

Water should not exist.

OK or NG

- OK >> GO TO 6.
- NG >> Replace EVAP control system pressure sensor.

6. CHECK EVAP CONTROL SYSTEM PRESSURE SENSOR

Refer to [EC-478, "Component Inspection"](#) .

OK or NG

- OK (With CONSULT-II)>>GO TO 7.
- OK (Without CONSULT-II)>>GO TO 8.
- NG >> Replace EVAP control system pressure sensor.

DTC P0443 EVAP CANISTER PURGE VOLUME CONTROL SOLENOID VALVE

7. CHECK EVAP CANISTER PURGE VOLUME CONTROL SOLENOID VALVE

With CONSULT-II

1. Turn ignition switch OFF.
2. Reconnect all harness connectors disconnected.
3. Start engine.
4. Perform "PURG VOL CONT/V" in "ACTIVE TEST" mode with CONSULT-II. Check that engine speed varies according to the valve opening.

OK or NG

- OK >> GO TO 9.
NG >> GO TO 8.

ACTIVE TEST	
PURG VOL CONT/V	XXX %
MONITOR	
ENG SPEED	XXX rpm
A/F ALPHA-B1	XX %
A/F ALPHA-B2	XX %

PBIB1678E

8. CHECK EVAP CANISTER PURGE VOLUME CONTROL SOLENOID VALVE

Refer to [EC-446, "Component Inspection"](#) .

OK or NG

- OK >> GO TO 9.
NG >> Replace EVAP canister purge volume control solenoid valve.

9. CHECK RUBBER TUBE FOR CLOGGING

1. Disconnect rubber tube connected to EVAP canister vent control valve.
2. Check the rubber tube for clogging.

OK or NG

- OK >> GO TO 10.
NG >> Clean the rubber tube using an air blower.

10. CHECK EVAP CANISTER VENT CONTROL VALVE

Refer to [EC-459, "Component Inspection"](#) .

OK or NG

- OK >> GO TO 11.
NG >> Replace EVAP canister vent control valve.

11. CHECK IF EVAP CANISTER SATURATED WITH WATER

1. Remove EVAP canister with EVAP canister vent control valve and EVAP control system pressure sensor attached.
2. Does water drain from the EVAP canister?.

Yes or No

- Yes >> GO TO 12.
No >> GO TO 14.

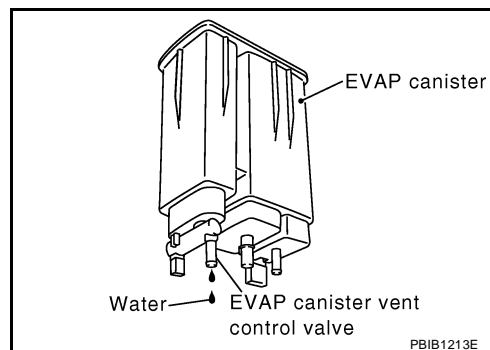

DTC P0443 EVAP CANISTER PURGE VOLUME CONTROL SOLENOID VALVE

12. CHECK EVAP CANISTER

Weigh the EVAP canister with the EVAP canister vent control valve and EVAP control system pressure sensor attached.

The weight should be less than 2.1 kg (4.6 lb).

OK or NG

- OK >> GO TO 14.
- NG >> GO TO 13.

13. DETECT MALFUNCTIONING PART

Check the following.

- EVAP canister for damage
- EVAP hose between EVAP canister and vehicle frame for clogging or poor connection

>> Repair hose or replace EVAP canister.

14. CHECK INTERMITTENT INCIDENT

Refer to [EC-149, "TROUBLE DIAGNOSIS FOR INTERMITTENT INCIDENT"](#) .

>> INSPECTION END

Component Inspection EVAP CANISTER PURGE VOLUME CONTROL SOLENOID VALVE

UBS00P90

Ⓟ With CONSULT-II

Check air passage continuity of EVAP canister purge volume control solenoid valve using "PURG VOL CONT/V" in "ACTIVE TEST" mode with CONSULT-II under the following conditions.

Condition (PURG VOL CONT/V value)	Air passage continuity between A and B
100%	Yes
0%	No

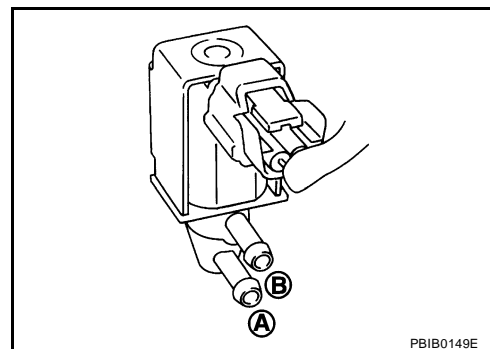

ⓧ Without CONSULT-II

Check air passage continuity of EVAP canister purge volume control solenoid valve under the following conditions.

Condition	Air passage continuity between A and B
12V direct current supply between terminals 1 and 2	Yes
No supply	No

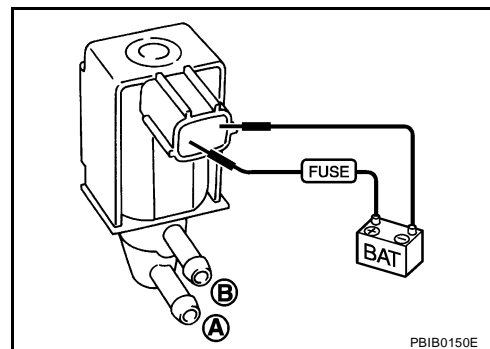

Removal and Installation EVAP CANISTER PURGE VOLUME CONTROL SOLENOID VALVE

UBS00P91

Refer to [EM-18, "INTAKE MANIFOLD COLLECTOR"](#) .

DTC P0444, P0445 EVAP CANISTER PURGE VOLUME CONTROL SOLENOID VALVE

DTC P0444, P0445 EVAP CANISTER PURGE VOLUME CONTROL SOLENOID VALVE

PF1:14920

Description SYSTEM DESCRIPTION

UBS00P92

Sensor	Input Signal to ECM	ECM function	Actuator
Crankshaft position sensor (POS) Camshaft position sensor (PHASE)	Engine speed*1	EVAP canister purge flow control	EVAP canister purge volume control solenoid valve
Mass air flow sensor	Amount of intake air		
Engine coolant temperature sensor	Engine coolant temperature		
Battery	Battery voltage*1		
Throttle position sensor	Throttle position		
Accelerator pedal position sensor	Accelerator pedal position		
Air fuel ratio (A/F) sensors 1	Density of oxygen in exhaust gas (Mixture ratio feedback signal)		
Fuel tank temperature sensor	Fuel temperature in fuel tank		
Wheel sensor	Vehicle speed*2		

*1: ECM determines the start signal status by the signals of engine speed and battery voltage.

*2: This signal is sent to the ECM through CAN communication line.

This system controls flow rate of fuel vapor from the EVAP canister. The opening of the vapor by-pass passage in the EVAP canister purge volume control solenoid valve changes to control the flow rate. The EVAP canister purge volume control solenoid valve repeats ON/OFF operation according to the signal sent from the ECM. The opening of the valve varies for optimum engine control. The optimum value stored in the ECM is determined by considering various engine conditions. When the engine is operating, the flow rate of fuel vapor from the EVAP canister is regulated as the air flow changes.

COMPONENT DESCRIPTION

The EVAP canister purge volume control solenoid valve uses a ON/OFF duty to control the flow rate of fuel vapor from the EVAP canister. The EVAP canister purge volume control solenoid valve is moved by ON/OFF pulses from the ECM. The longer the ON pulse, the greater the amount of fuel vapor that will flow through the valve.

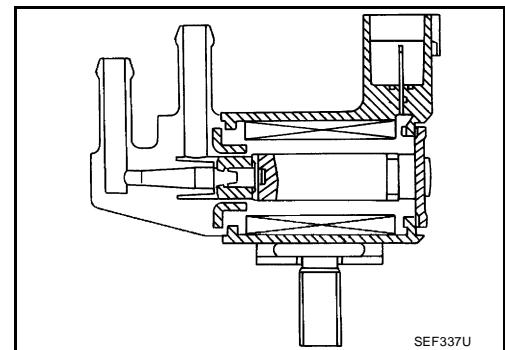

CONSULT-II Reference Value in Data Monitor Mode

UBS00P93

Specification data are reference values.

MONITOR ITEM	CONDITION	SPECIFICATION
PURG VOL C/V	<ul style="list-style-type: none"> ● Engine: After warming up ● Shift lever: P or N ● Air conditioner switch: OFF ● No load 	Idle (Accelerator pedal is not depressed even slightly, after engine starting)
		2,000 rpm
		0%
		—

DTC P0444, P0445 EVAP CANISTER PURGE VOLUME CONTROL SOLENOID VALVE

On Board Diagnosis Logic

UBS00P94

DTC No.	Trouble diagnosis name	DTC detecting condition	Possible cause
P0444 0444	EVAP canister purge volume control solenoid valve circuit open	An excessively low voltage signal is sent to ECM through the valve	<ul style="list-style-type: none"> ● Harness or connectors (The solenoid valve circuit is open or shorted.) ● EVAP canister purge volume control solenoid valve
P0445 0445	EVAP canister purge volume control solenoid valve circuit shorted	An excessively high voltage signal is sent to ECM through the valve	<ul style="list-style-type: none"> ● Harness or connectors (The solenoid valve circuit is shorted.) ● EVAP canister purge volume control solenoid valve

DTC Confirmation Procedure

UBS00P95

NOTE:

If DTC Confirmation Procedure has been previously conducted, always turn ignition switch OFF and wait at least 10 seconds before conducting the next test.

TESTING CONDITION:

Before performing the following procedure, confirm battery voltage is more than 11V at idle.

WITH CONSULT-II

1. Turn ignition switch ON.
2. Select "DATA MONITOR" mode with CONSULT-II.
3. Start engine and let it idle for at least 13 seconds.
4. If 1st trip DTC is detected, go to [EC-451, "Diagnostic Procedure"](#)

DATA MONITOR	
MONITOR	NO DTC
ENG SPEED	XXX rpm

SEF058Y

WITH GST

Follow the procedure "WITH CONSULT-II" above.

DTC P0444, P0445 EVAP CANISTER PURGE VOLUME CONTROL SOLENOID VALVE

UBS00P96

Wiring Diagram

EC-PGC/V-01

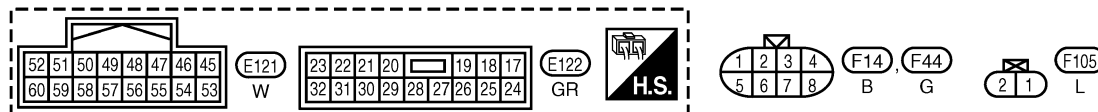
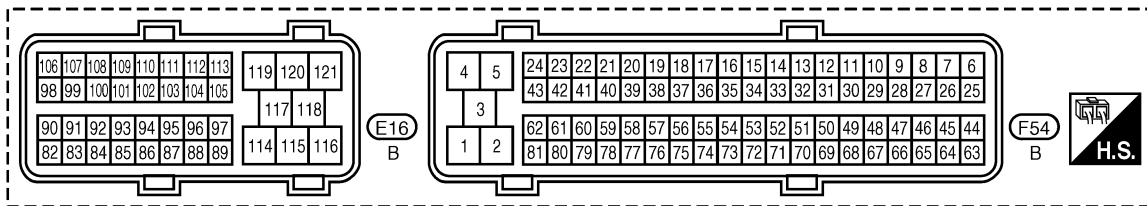
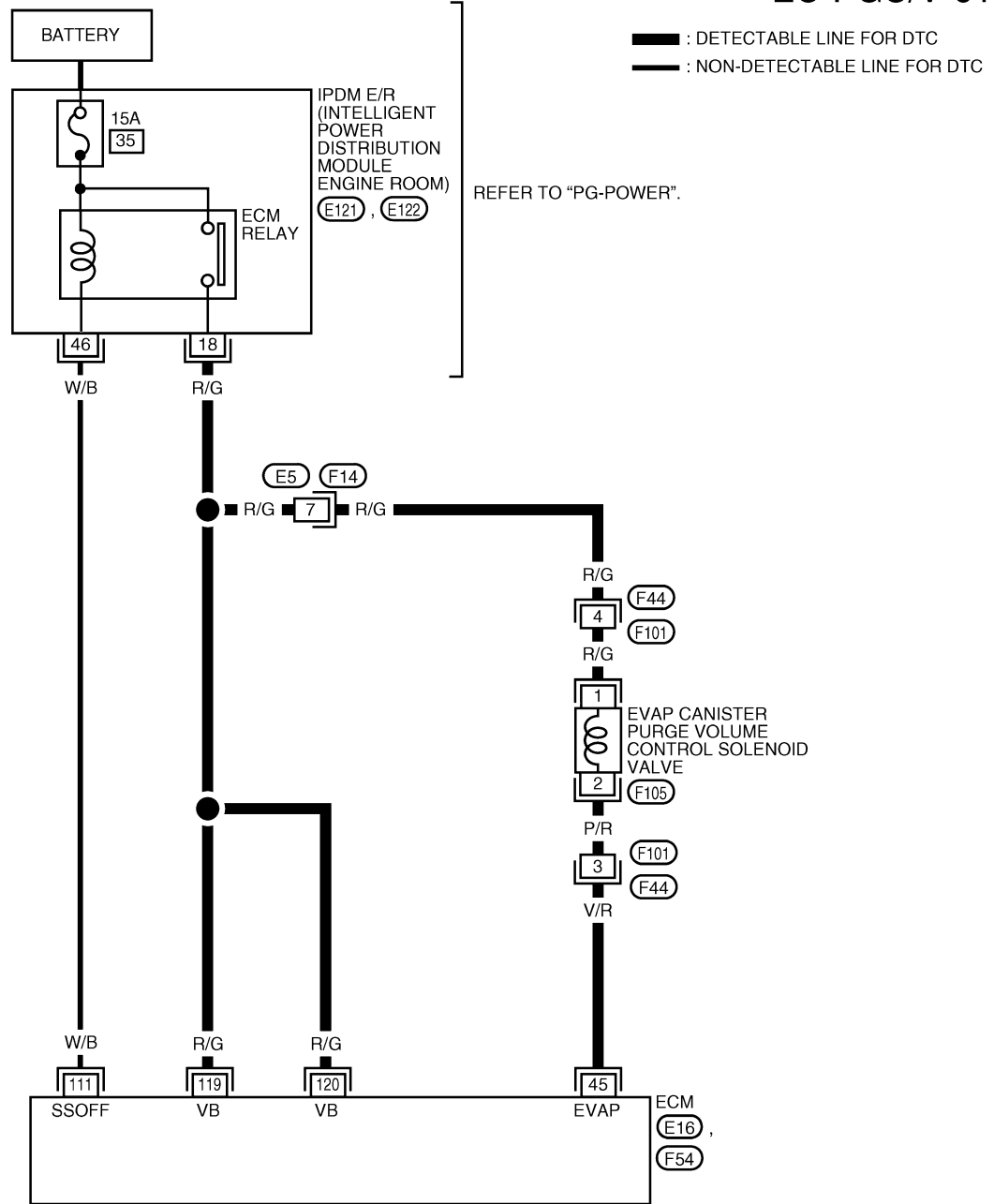

BBWA2517E

DTC P0444, P0445 EVAP CANISTER PURGE VOLUME CONTROL SOLENOID VALVE

Specification data are reference values and are measured between each terminal and ground.
Pulse signal is measured by CONSULT-II.

CAUTION:

Do not use ECM ground terminals when measuring input/output voltage. Doing so may result in damage to the ECM's transistor. Use a ground other than ECM terminals, such as the ground.

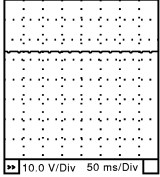
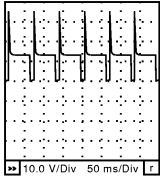
TER-MINAL NO.	WIRE COLOR	ITEM	CONDITION	DATA (DC Voltage)
45	V/R	EVAP canister purge volume control solenoid valve	[Engine is running] <ul style="list-style-type: none"> ● Idle speed ● Accelerator pedal: Not depressed even slightly, after engine starting 	BATTERY VOLTAGE (11 - 14V)★  <small>10.0 V/Div 50 ms/Div</small> SEC990C
			[Engine is running] <ul style="list-style-type: none"> ● Engine speed: About 2,000 rpm (More than 100 seconds after starting engine) 	BATTERY VOLTAGE (11 - 14V)★  <small>10.0 V/Div 50 ms/Div</small> SEC991C
111	W/B	ECM relay (Self shut-off)	[Engine is running] [Ignition switch: OFF] <ul style="list-style-type: none"> ● For a few seconds after turning ignition switch OFF 	0 - 1.5V
			[Ignition switch: OFF] <ul style="list-style-type: none"> ● More than a few seconds after turning ignition switch OFF 	BATTERY VOLTAGE (11 - 14V)
119 120	R/G R/G	Power supply for ECM	[Ignition switch: ON]	BATTERY VOLTAGE (11 - 14V)

★: Average voltage for pulse signal (Actual pulse signal can be confirmed by oscilloscope.)

DTC P0444, P0445 EVAP CANISTER PURGE VOLUME CONTROL SOLENOID VALVE

UBS00P97

Diagnostic Procedure

1. CHECK EVAP CANISTER PURGE VOLUME CONTROL SOLENOID VALVE POWER SUPPLY CIRCUIT

1. Turn ignition switch OFF.
2. Disconnect EVAP canister purge volume control solenoid valve harness connector.
3. Turn ignition switch ON.

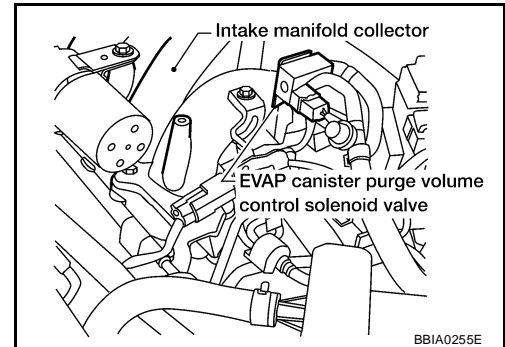

4. Check voltage between EVAP canister purge volume control solenoid valve terminal 1 and ground with CONSULT-II or tester.

Voltage: Battery voltage

OK or NG

- OK >> GO TO 3.
- NG >> GO TO 2.

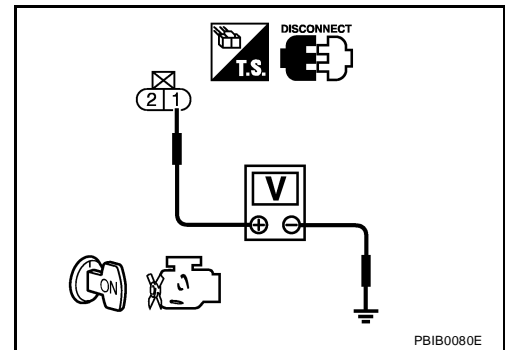

2. DETECT MALFUNCTIONING PART

Check the following.

- Harness connectors E5, F14
- Harness connectors F44, F101
- Harness for open or short between EVAP canister purge volume control solenoid valve and IPDM E/R
- Harness for open or short between EVAP canister purge volume control solenoid valve and ECM

>> Repair harness or connectors.

3. CHECK EVAP CANISTER PURGE VOLUME CONTROL SOLENOID VALVE OUTPUT SIGNAL CIRCUIT FOR OPEN AND SHORT

1. Turn ignition switch OFF.
2. Disconnect ECM harness connector.
3. Check harness continuity between ECM terminal 45 and EVAP canister purge volume control solenoid valve terminal 2. Refer to Wiring Diagram.

Continuity should exist.

4. Also check harness for short to ground and short to power.

OK or NG

- OK (With CONSULT-II)>>GO TO 5.
- OK (Without CONSULT-II)>>GO TO 6.
- NG >> GO TO 4.

DTC P0444, P0445 EVAP CANISTER PURGE VOLUME CONTROL SOLENOID VALVE

4. DETECT MALFUNCTIONING PART

Check the following.

- Harness connectors F44, F101
- Harness for open or short between EVAP canister purge volume control solenoid valve and ECM

>> Repair open circuit or short to ground or short to power in harness or connectors.

5. CHECK EVAP CANISTER PURGE VOLUME CONTROL SOLENOID VALVE OPERATION

Ⓟ With CONSULT-II

1. Reconnect all harness connectors disconnected.
2. Start engine.
3. Perform "PURG VOL CONT/V" in "ACTIVE TEST" mode with CONSULT-II. Check that engine speed varies according to the valve opening.

OK or NG

- OK >> GO TO 7.
 NG >> GO TO 6.

ACTIVE TEST	
PURG VOL CONT/V	XXX %
MONITOR	
ENG SPEED	XXX rpm
A/F ALPHA-B1	XX %
A/F ALPHA-B2	XX %

PBIB1678E

6. CHECK EVAP CANISTER PURGE VOLUME CONTROL SOLENOID VALVE

Refer to [EC-452, "Component Inspection"](#) .

OK or NG

- OK >> GO TO 7.
 NG >> Replace EVAP canister purge volume control solenoid valve.

7. CHECK INTERMITTENT INCIDENT

Refer to [EC-149, "TROUBLE DIAGNOSIS FOR INTERMITTENT INCIDENT"](#) .

>> INSPECTION END

Component Inspection EVAP CANISTER PURGE VOLUME CONTROL SOLENOID VALVE

UBS00P98

Ⓟ With CONSULT-II

Check air passage continuity of EVAP canister purge volume control solenoid valve using "PURG VOL CONT/V" in "ACTIVE TEST" mode with CONSULT-II under the following conditions.

Condition (PURG VOL CONT/V value)	Air passage continuity between A and B
100%	Yes
0%	No

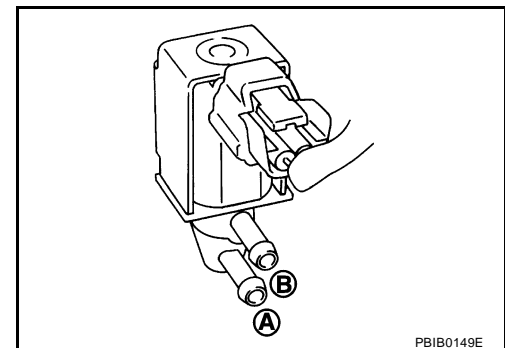

DTC P0444, P0445 EVAP CANISTER PURGE VOLUME CONTROL SOLENOID VALVE

⊗ Without CONSULT-II

Check air passage continuity of EVAP canister purge volume control solenoid valve under the following conditions.

Condition	Air passage continuity between A and B
12V direct current supply between terminals 1 and 2	Yes
No supply	No

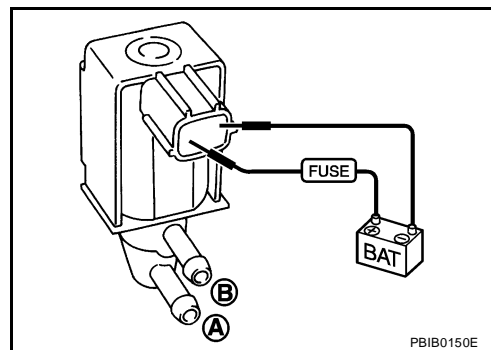

Removal and Installation

EVAP CANISTER PURGE VOLUME CONTROL SOLENOID VALVE

Refer to [EM-18, "INTAKE MANIFOLD COLLECTOR"](#)

UBS00P99

DTC P0447 EVAP CANISTER VENT CONTROL VALVE

DTC P0447 EVAP CANISTER VENT CONTROL VALVE

PF1:14935

Component Description

UBS00P9A

The EVAP canister vent control valve is located on the EVAP canister and is used to seal the canister vent.

This solenoid valve responds to signals from the ECM. When the ECM sends an ON signal, the coil in the solenoid valve is energized. A plunger will then move to seal the canister vent. The ability to seal the vent is necessary for the on board diagnosis of other evaporative emission control system components.

This solenoid valve is used only for diagnosis, and usually remains opened.

When the vent is closed, under normal purge conditions, the evaporative emission control system is depressurized and allows EVAP Control System diagnosis.

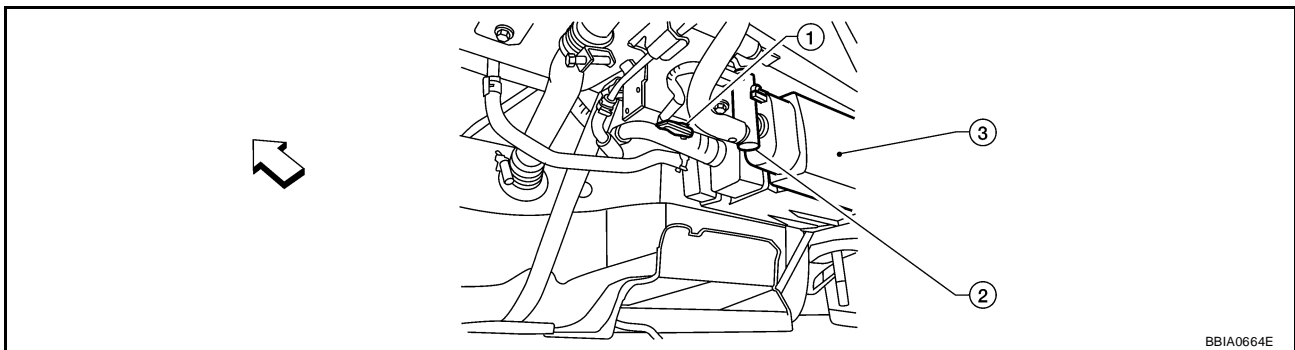
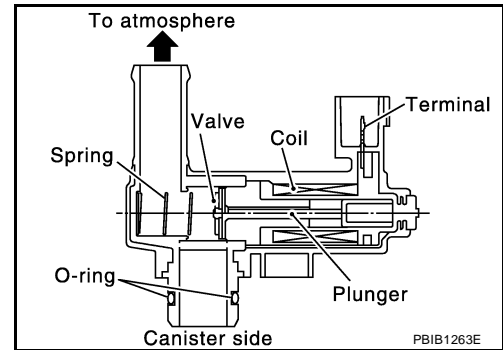

↔ Vehicle front

1. EVAP control system pressure sensor 2. EVAP canister vent control valve 3. EVAP canister

CONSULT-II Reference Value in Data Monitor Mode

UBS00P9B

Specification data are reference values.

MONITOR ITEM	CONDITION	SPECIFICATION
VENT CONT/V	● Ignition switch: ON	OFF

On Board Diagnosis Logic

UBS00P9C

DTC No.	Trouble diagnosis name	DTC detecting condition	Possible cause
P0447 0447	EVAP canister vent control valve circuit open	An improper voltage signal is sent to ECM through EVAP canister vent control valve.	<ul style="list-style-type: none"> ● Harness or connectors (The valve circuit is open or shorted.) ● EVAP canister vent control valve

DTC P0447 EVAP CANISTER VENT CONTROL VALVE

UBS00P9D

DTC Confirmation Procedure

NOTE:

If DTC Confirmation Procedure has been previously conducted, always turn ignition switch OFF and wait at least 10 seconds before conducting the next test.

TESTING CONDITION:

Before performing the following procedure, confirm battery voltage is more than 11V at idle.

WITH CONSULT-II

1. Turn ignition switch ON.
2. Select "DATA MONITOR" mode with CONSULT-II.
3. Start engine and wait at least 8 seconds.
4. If 1st trip DTC is detected, go to [EC-457, "Diagnostic Procedure"](#)

DATA MONITOR	
MONITOR	NO DTC
ENG SPEED	XXX rpm

SEF058Y

WITH GST

Follow the procedure "WITH CONSULT-II" above.

DTC P0447 EVAP CANISTER VENT CONTROL VALVE

Specification data are reference values and are measured between each terminal and ground.

CAUTION:

Do not use ECM ground terminals when measuring input/output voltage. Doing so may result in damage to the ECM's transistor. Use a ground other than ECM terminals, such as the ground.

TERMINAL NO.	WIRE COLOR	ITEM	CONDITION	DATA (DC Voltage)
111	W/B	ECM relay (Self shut-off)	[Engine is running] [Ignition switch: OFF] ● For a few seconds after turning ignition switch OFF	0 - 1.5V
			[Ignition switch: OFF] ● More than a few seconds after turning ignition switch OFF	BATTERY VOLTAGE (11 - 14V)
117	LG/B	EVAP canister vent control valve	[Ignition switch: ON]	BATTERY VOLTAGE (11 - 14V)
119 120	R/G R/G	Power supply for ECM	[Ignition switch: ON]	BATTERY VOLTAGE (11 - 14V)

Diagnostic Procedure

UBS00P9F

1. INSPECTION START

Do you have CONSULT-II?

Yes or No

- Yes >> GO TO 2.
- No >> GO TO 3.

2. CHECK EVAP CANISTER VENT CONTROL VALVE CIRCUIT

Ⓜ With CONSULT-II

1. Turn ignition switch OFF and then turn ON.
2. Select "VENT CONTROL/V" in "ACTIVE TEST" mode with CONSULT-II.
3. Touch "ON/OFF" on CONSULT-II screen.
4. Check for operating sound of the valve.

Clicking noise should be heard.

OK or NG

- OK >> GO TO 7.
- NG >> GO TO 3.

ACTIVE TEST	
VENT CONTROL/V	OFF
MONITOR	
ENG SPEED	XXX rpm
A/F ALPHA-B1	XXX %
A/F ALPHA-B2	XXX %

PBIB1679E

DTC P0447 EVAP CANISTER VENT CONTROL VALVE

3. CHECK EVAP CANISTER VENT CONTROL VALVE POWER SUPPLY CIRCUIT

1. Turn ignition switch OFF.
2. Disconnect EVAP canister vent control valve harness connector.

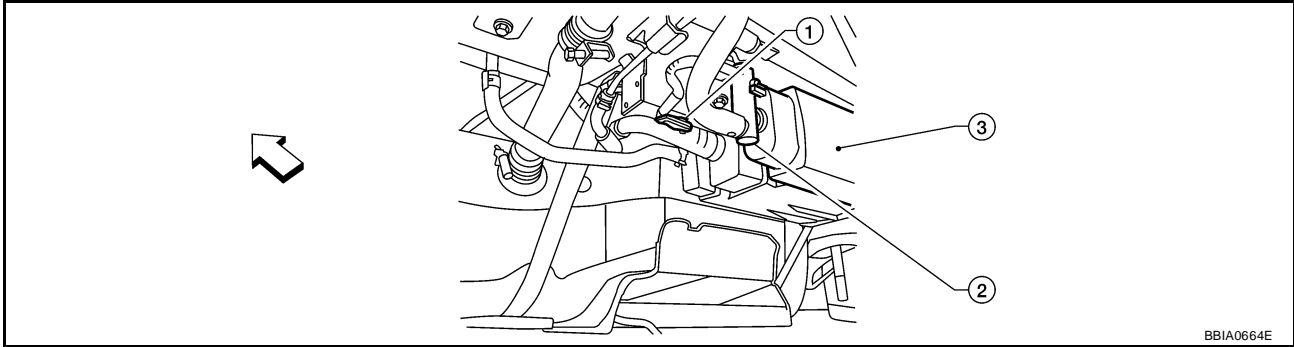

←: Vehicle front

1. EVAP control system pressure sensor
2. EVAP canister vent control valve
3. EVAP canister

3. Turn ignition switch ON.
4. Check voltage between EVAP canister vent control valve terminal 1 and ground with CONSULT-II or tester.

Voltage: Battery voltage

OK or NG

- OK >> GO TO 5.
- NG >> GO TO 4.

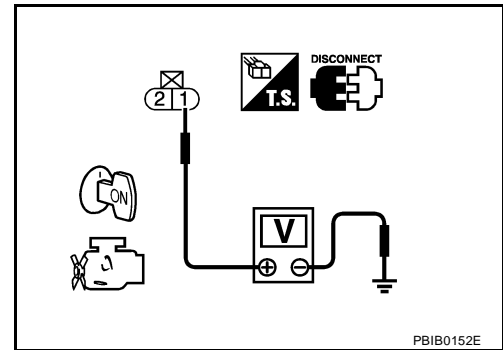

4. DETECT MALFUNCTIONING PART

Check the following.

- Harness connectors B107, E139
- Harness for open or short between EVAP canister vent control valve and IPDM E/R

>> Repair harness or connectors.

5. CHECK EVAP CANISTER VENT CONTROL VALVE OUTPUT SIGNAL CIRCUIT FOR OPEN AND SHORT

1. Turn ignition switch OFF.
2. Disconnect ECM harness connector.
3. Check harness continuity between ECM terminal 117 and EVAP canister vent control valve terminal 2. Refer to Wiring Diagram.

Continuity should exist.

4. Also check harness for short to ground and short to power.

OK or NG

- OK >> GO TO 7.
- NG >> GO TO 6.

DTC P0447 EVAP CANISTER VENT CONTROL VALVE

6. DETECT MALFUNCTIONING PART

Check the following.

- Harness connectors B107, E139
- Harness for open or short between EVAP canister vent control valve and ECM

>> Repair open circuit or short to ground or short to power in harness or connectors.

7. CHECK RUBBER TUBE FOR CLOGGING

1. Disconnect rubber tube connected to EVAP canister vent control valve.
2. Check the rubber tube for clogging.

OK or NG

OK >> GO TO 8.

NG >> Clean the rubber tube using an air blower.

8. CHECK EVAP CANISTER VENT CONTROL VALVE

Refer to [EC-459, "Component Inspection"](#) .

OK or NG

OK >> GO TO 9.

NG >> Replace EVAP canister vent control valve.

9. CHECK INTERMITTENT INCIDENT

Refer to [EC-149, "TROUBLE DIAGNOSIS FOR INTERMITTENT INCIDENT"](#) .

>> INSPECTION END

Component Inspection EVAP CANISTER VENT CONTROL VALVE

UBS00P9G

 With CONSULT-II

1. Remove EVAP canister vent control valve from EVAP canister.
2. Check portion **B** of EVAP canister vent control valve for being rusted.
If NG, replace EVAP canister vent control valve.
If OK, go to next step.
3. Reconnect all harness connectors disconnected.
4. Turn ignition switch ON.

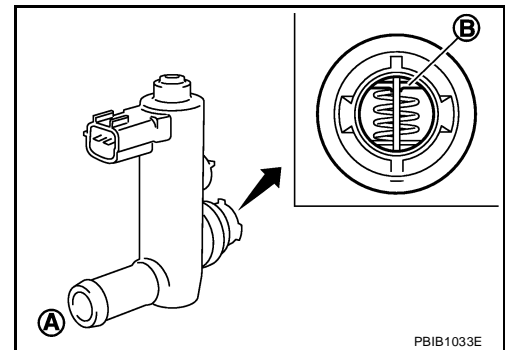

5. Perform "VENT CONTROL/V" in "ACTIVE TEST" mode.
6. Check air passage continuity and operation delay time.
Make sure new O-ring is installed properly.

Condition VENT CONTROL/V	Air passage continuity between A and B
ON	No
OFF	Yes

Operation takes less than 1 second.

If NG, replace EVAP canister vent control valve.

If OK, go to next step.

ACTIVE TEST	
VENT CONTROL/V	OFF
MONITOR	
ENG SPEED	XXX rpm
A/F ALPHA-B1	XXX %
A/F ALPHA-B2	XXX %

PBIB1679E

DTC P0447 EVAP CANISTER VENT CONTROL VALVE

7. Clean the air passage (Portion **A** to **B**) of EVAP canister vent control valve using an air blower.
8. Perform step 6 again.

⊗ **Without CONSULT-II**

1. Remove EVAP canister vent control valve from EVAP canister.
2. Check portion **B** of EVAP canister vent control valve for being rusted.

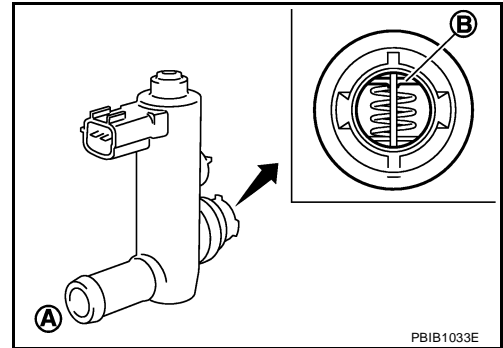

3. Check air passage continuity and operation delay time under the following conditions.

Make sure new O-ring is installed properly.

Condition	Air passage continuity between A and B
12V direct current supply between terminals 1 and 2	No
OFF	Yes

Operation takes less than 1 second.

If NG, replace EVAP canister vent control valve.
If OK, go to next step.

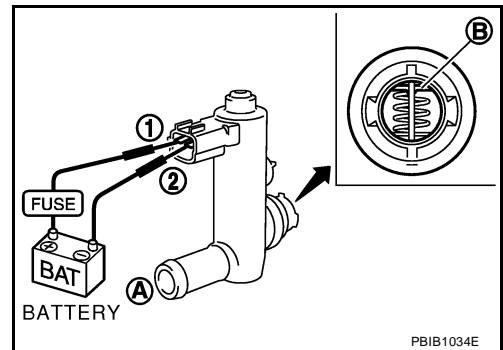

4. Clean the air passage (Portion **A** to **B**) of EVAP canister vent control valve using an air blower.
5. Perform step 3 again.

DTC P0448 EVAP CANISTER VENT CONTROL VALVE

DTC P0448 EVAP CANISTER VENT CONTROL VALVE

PF16935

Component Description

UBS00P9H

The EVAP canister vent control valve is located on the EVAP canister and is used to seal the canister vent.

This solenoid valve responds to signals from the ECM. When the ECM sends an ON signal, the coil in the solenoid valve is energized. A plunger will then move to seal the canister vent. The ability to seal the vent is necessary for the on board diagnosis of other evaporative emission control system components.

This solenoid valve is used only for diagnosis, and usually remains opened.

When the vent is closed, under normal purge conditions, the evaporative emission control system is depressurized and allows EVAP Control System diagnosis.

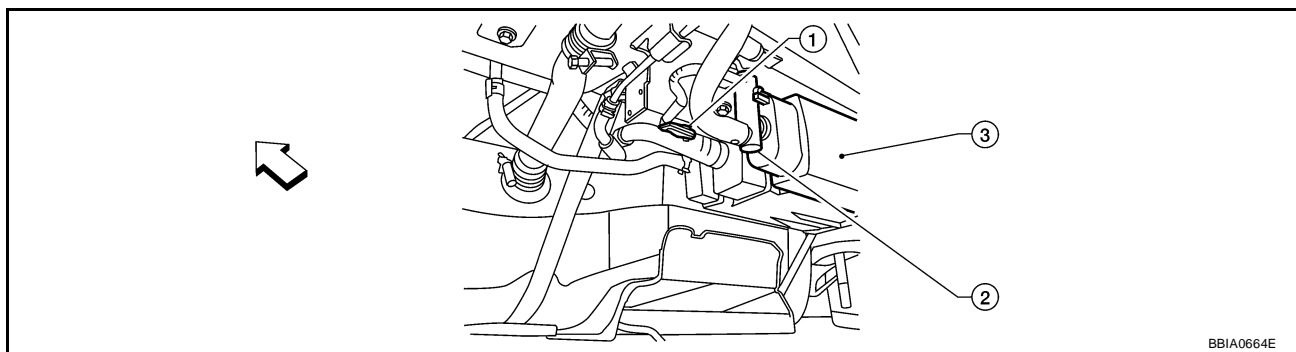
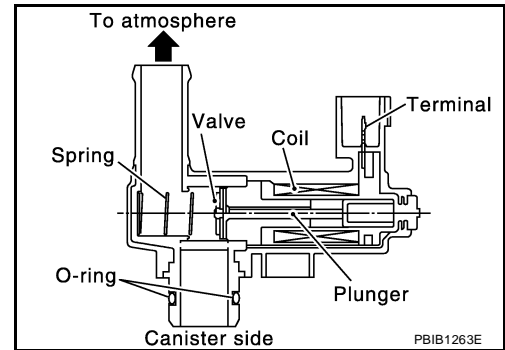

← Vehicle front

1. EVAP control system pressure sensor 2. EVAP canister vent control valve 3. EVAP canister

CONSULT-II Reference Value in Data Monitor Mode

UBS00P9I

Specification data are reference values.

MONITOR ITEM	CONDITION	SPECIFICATION
VENT CONT/V	● Ignition switch: ON	OFF

On Board Diagnosis Logic

UBS00P9J

DTC No.	Trouble diagnosis name	DTC detecting condition	Possible cause
P0448 0448	EVAP canister vent control valve close	EVAP canister vent control valve remains closed under specified driving conditions.	<ul style="list-style-type: none"> ● EVAP canister vent control valve ● EVAP control system pressure sensor and the circuit ● Blocked rubber tube to EVAP canister vent control valve ● EVAP canister is saturated with water

DTC P0448 EVAP CANISTER VENT CONTROL VALVE

UBS00P9K

DTC Confirmation Procedure

NOTE:

If DTC Confirmation Procedure has been previously conducted, always turn ignition switch OFF and wait at least 10 seconds before conducting the next test.

④ WITH CONSULT-II

1. Turn ignition switch ON and wait at least 5 seconds.
2. Turn ignition switch OFF and wait at least 10 seconds.
3. Turn ignition switch ON and select "DATA MONITOR" mode with CONSULT-II.
4. Start engine and let it idle for at least 1 minute.
5. Repeat next procedures three times.
 - a. Increase the engine speed up to 3,000 to 3,500 rpm and keep it for 2 minutes and 50 seconds to 3 minutes.
Never exceed 3 minutes.
 - b. Fully released accelerator pedal and keep engine idle for about 5 seconds.
6. If 1st trip DTC is detected, go to [EC-464, "Diagnostic Procedure"](#)

DATA MONITOR	
MONITOR	NO DTC
ENG SPEED	XXX rpm

SEF058Y

If 1st trip DTC is not detected, go to the next step.

7. Repeat next procedure 20 times.
 - a. Quickly increase the engine speed up to 4,000 to 4,500 rpm or more and keep it for 25 to 30 seconds.
 - b. Fully released accelerator pedal and keep engine idle for at least 35 seconds.

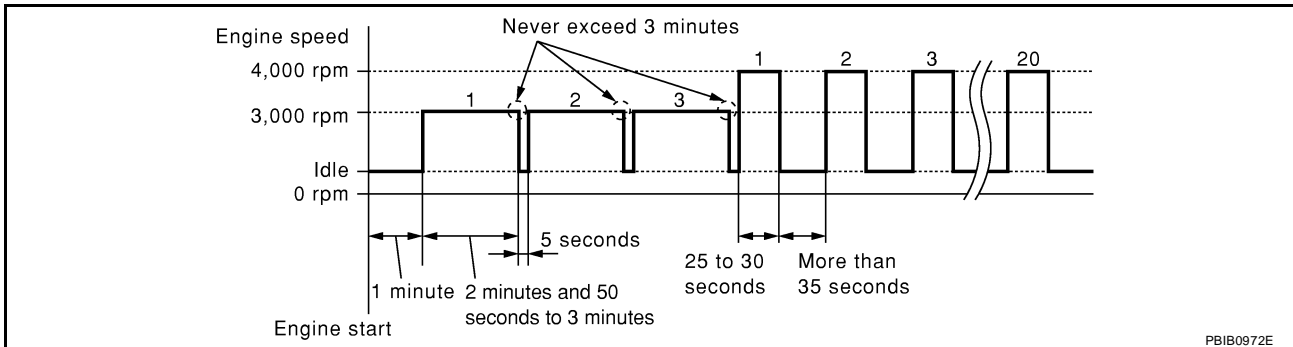

8. If 1st trip DTC is detected, go to [EC-464, "Diagnostic Procedure"](#).

④ WITH GST

Follow the procedure "WITH CONSULT-II" above.

DTC P0448 EVAP CANISTER VENT CONTROL VALVE

UBS00P9L

Wiring Diagram

EC-VENT/V-01

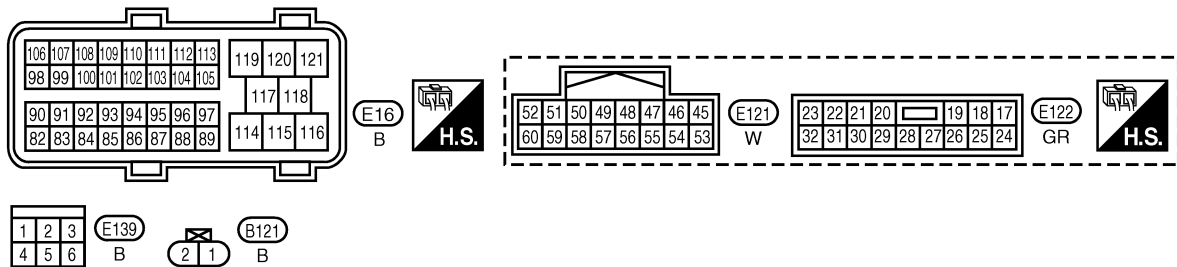
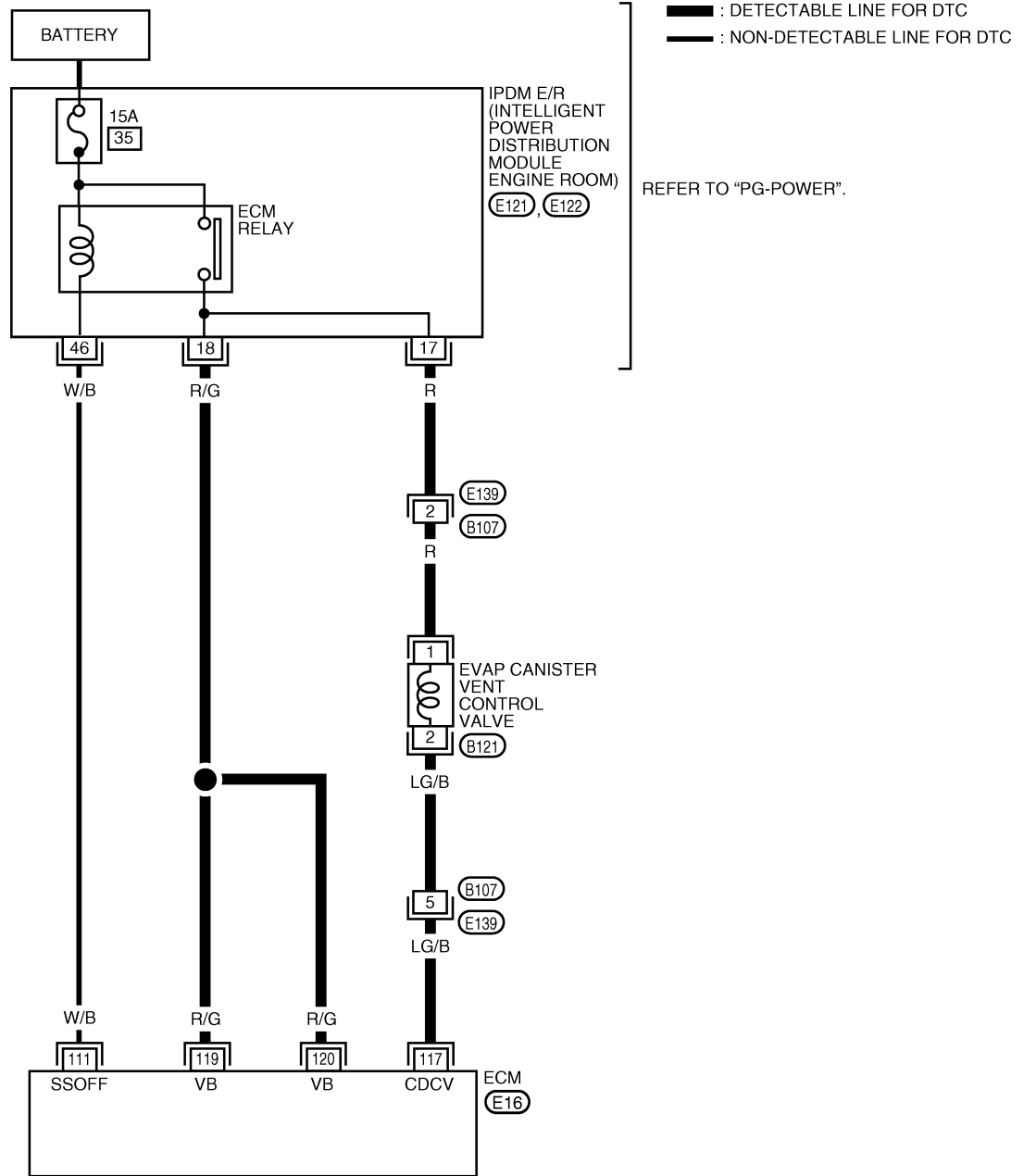

BBWA2521E

DTC P0448 EVAP CANISTER VENT CONTROL VALVE

Specification data are reference values and are measured between each terminal and ground.

CAUTION:

Do not use ECM ground terminals when measuring input/output voltage. Doing so may result in damage to the ECM's transistor. Use a ground other than ECM terminals, such as the ground.

TER-MINAL NO.	WIRE COLOR	ITEM	CONDITION	DATA (DC Voltage)
111	W/B	ECM relay (Self shut-off)	[Engine is running] [Ignition switch: OFF] ● For a few seconds after turning ignition switch OFF	0 - 1.5V
			[Ignition switch: OFF] ● More than a few seconds after turning ignition switch OFF	BATTERY VOLTAGE (11 - 14V)
117	LG/B	EVAP canister vent control valve	[Ignition switch: ON]	BATTERY VOLTAGE (11 - 14V)
119 120	R/G R/G	Power supply for ECM	[Ignition switch: ON]	BATTERY VOLTAGE (11 - 14V)

Diagnostic Procedure

UBS00P9M

1. CHECK RUBBER TUBE

1. Turn ignition switch OFF.
2. Disconnect rubber tube connected to EVAP canister vent control valve.

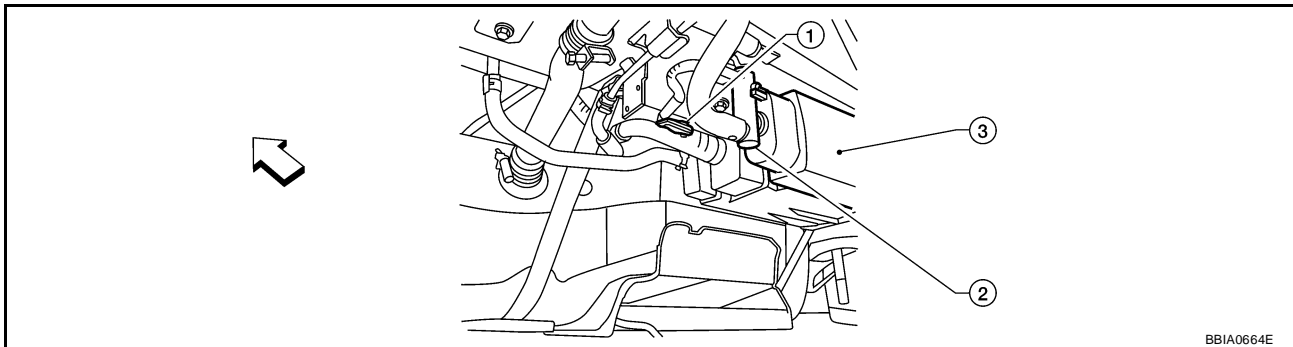

← Vehicle front

1. EVAP control system pressure sensor
2. EVAP canister vent control valve
3. EVAP canister

3. Check the rubber tube for clogging.

OK or NG

- OK >> GO TO 2.
- NG >> Clean rubber tube using an air blower.

2. CHECK EVAP CANISTER VENT CONTROL VALVE

Refer to [EC-466, "Component Inspection"](#).

OK or NG

- OK >> GO TO 3.
- NG >> Replace EVAP canister vent control valve.

DTC P0448 EVAP CANISTER VENT CONTROL VALVE

3. CHECK IF EVAP CANISTER SATURATED WITH WATER

1. Remove EVAP canister with EVAP canister vent control valve and EVAP control system pressure sensor attached.
2. Does water drain from the EVAP canister?.

Yes or No

- Yes >> GO TO 4.
- No >> GO TO 6.

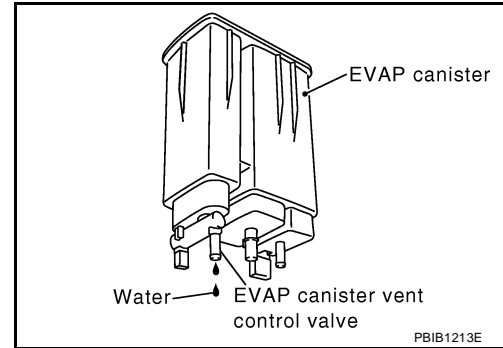

4. CHECK EVAP CANISTER

Weigh the EVAP canister with the EVAP canister vent control valve and EVAP control system pressure sensor attached.

The weight should be less than 2.1 kg (4.6 lb).

OK or NG

- OK >> GO TO 6.
- NG >> GO TO 5.

5. DETECT MALFUNCTIONING PART

Check the following.

- EVAP canister for damage
- EVAP hose between EVAP canister and vehicle frame for clogging or poor connection

>> Repair hose or replace EVAP canister.

6. CHECK EVAP CONTROL SYSTEM PRESSURE SENSOR CONNECTOR

1. Disconnect EVAP control system pressure sensor harness connector.
2. Check connectors for water.

Water should not exist.

OK or NG

- OK >> GO TO 7.
- NG >> Replace EVAP control system pressure sensor.

7. CHECK EVAP CONTROL SYSTEM PRESSURE SENSOR

Refer to [EC-478, "Component Inspection"](#) .

OK or NG

- OK >> GO TO 8.
- NG >> Replace EVAP control system pressure sensor.

8. CHECK INTERMITTENT INCIDENT

Refer to [EC-149, "TROUBLE DIAGNOSIS FOR INTERMITTENT INCIDENT"](#) .

>> **INSPECTION END**

DTC P0448 EVAP CANISTER VENT CONTROL VALVE

UBS00P9N

Component Inspection EVAP CANISTER VENT CONTROL VALVE

With CONSULT-II

1. Remove EVAP canister vent control valve from EVAP canister.
2. Check portion **B** of EVAP canister vent control valve for being rusted.
If NG, replace EVAP canister vent control valve.
If OK, go to next step.
3. Reconnect harness connectors disconnected.
4. Turn ignition switch ON.

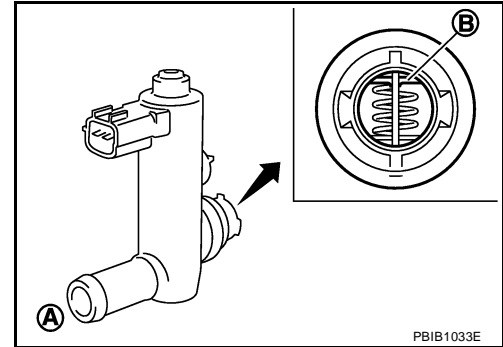

5. Perform "VENT CONTROL/V" in "ACTIVE TEST" mode.
6. Check air passage continuity and operation delay time.
Make sure new O-ring is installed properly.

Condition VENT CONTROL/V	Air passage continuity between A and B
ON	No
OFF	Yes

Operation takes less than 1 second.

If NG, replace EVAP canister vent control valve.
If OK, go to next step.

ACTIVE TEST	
VENT CONTROL/V	OFF
MONITOR	
ENG SPEED	XXX rpm
A/F ALPHA-B1	XXX %
A/F ALPHA-B2	XXX %

PBIB1679E

7. Clean the air passage (Portion **A** to **B**) of EVAP canister vent control valve using an air blower.
8. Perform step 6 again.

Without CONSULT-II

1. Remove EVAP canister vent control valve from EVAP canister.
2. Check portion **B** of EVAP canister vent control valve for being rusted.

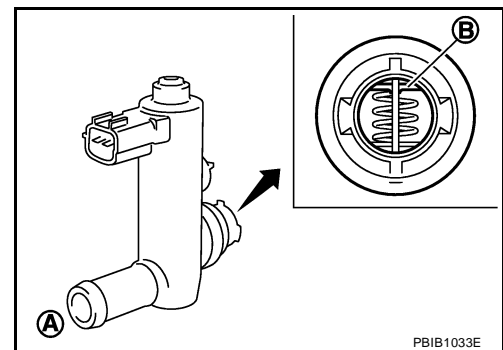

3. Check air passage continuity and operation delay time under the following conditions.
Make sure new O-ring is installed properly.

Condition	Air passage continuity between A and B
12V direct current supply between terminals 1 and 2	No
OFF	Yes

Operation takes less than 1 second.

If NG, replace EVAP canister vent control valve.
If OK, go to next step.

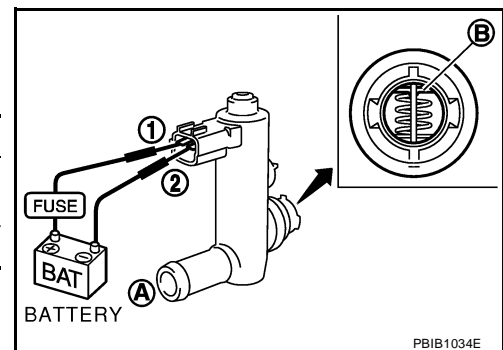

4. Clean the air passage (Portion **A** to **B**) of EVAP canister vent control valve using an air blower.

DTC P0448 EVAP CANISTER VENT CONTROL VALVE

5. Perform step 3 again.

A

EC

C

D

E

F

G

H

I

J

K

L

M

DTC P0451 EVAP CONTROL SYSTEM PRESSURE SENSOR

DTC P0451 EVAP CONTROL SYSTEM PRESSURE SENSOR

PF0:22365

Component Description

UBS00P90

The EVAP control system pressure sensor detects pressure in the purge line. The sensor output voltage to the ECM increases as pressure increases.

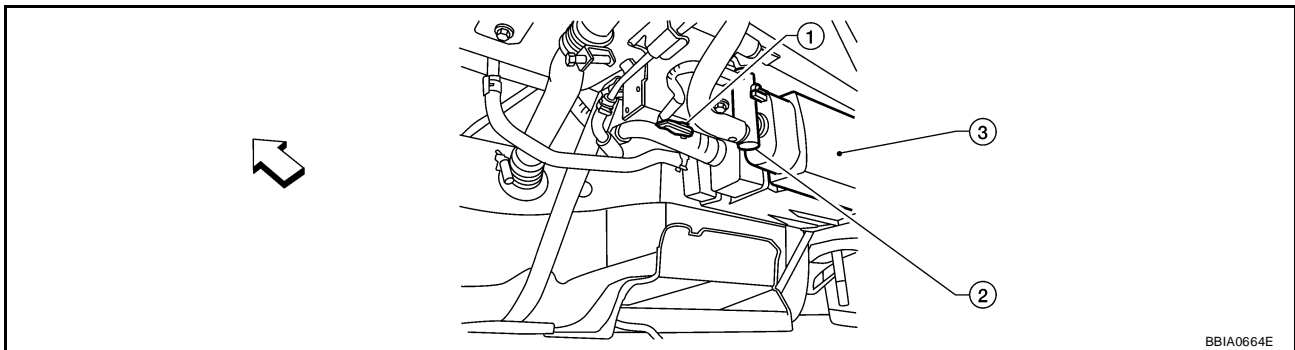
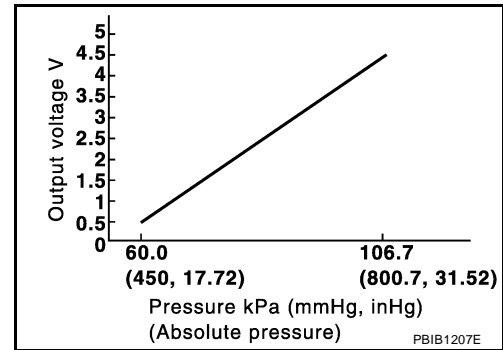

BBA0664E

← Vehicle front

1. EVAP control system pressure sensor 2. EVAP canister vent control valve 3. EVAP canister

CONSULT-II Reference Value in Data Monitor Mode

UBS00P9P

Specification data are reference values.

MONITOR ITEM	CONDITION	SPECIFICATION
EVAP SYS PRES	● Ignition switch: ON	Approx. 1.8 - 4.8V

On Board Diagnosis Logic

UBS00P9Q

NOTE:

If DTC P0451 is displayed with DTC P0643, first perform the trouble diagnosis for DTC P0643. Refer to [EC-529, "DTC P0643 SENSOR POWER SUPPLY"](#).

DTC No.	Trouble diagnosis name	DTC detecting condition	Possible cause
P0451 0451	EVAP control system pressure sensor performance	ECM detects a sloshing signal from the EVAP control system pressure sensor	<ul style="list-style-type: none"> ● Harness or connectors ● EVAP control system pressure sensor

DTC P0451 EVAP CONTROL SYSTEM PRESSURE SENSOR

UBS00P9R

DTC Confirmation Procedure

NOTE:

If DTC Confirmation Procedure has been previously conducted, always turn ignition switch OFF and wait at least 10 seconds before conducting the next test.

④ WITH CONSULT-II

1. Turn ignition switch OFF and wait at least 10 seconds.
2. Turn ignition switch ON and select "DATA MONITOR" mode with CONSULT-II.
3. Start engine and wait at least 40 seconds.

NOTE:

Do not depress accelerator pedal even slightly.

If 1st trip DTC is detected, go to [EC-470, "Diagnostic Procedure"](#)

DATA MONITOR	
MONITOR	NO DTC
ENG SPEED	XXX rpm
COOLAN TEMP/S	XXX °C
FUEL T/TMP SE	XXX °C

SEF194Y

④ WITH GST

Follow the procedure "WITH CONSULT-II" above.

A

EC

C

D

E

F

G

H

I

J

K

L

M

DTC P0451 EVAP CONTROL SYSTEM PRESSURE SENSOR

UBS00P9S

Diagnostic Procedure

1. CHECK GROUND CONNECTIONS

1. Turn ignition switch OFF.
2. Loosen and retighten three ground screws on the body. Refer to [EC-158, "Ground Inspection"](#).

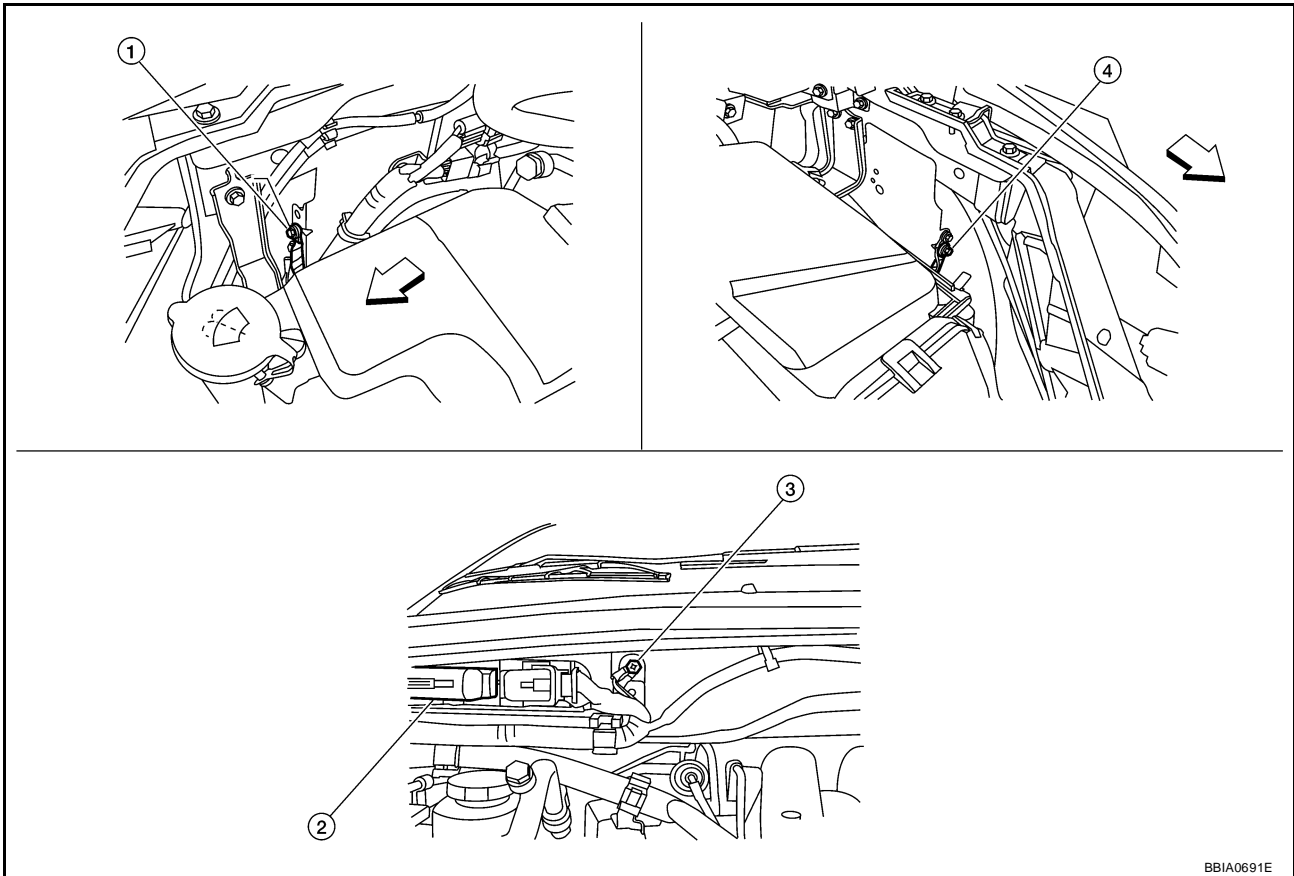

BBI A0691E

← Vehicle front

1. Body ground E24

2. ECM

3. Body ground E9

4. Body ground E15

OK or NG

OK >> GO TO 2.

NG >> Repair or replace ground connections.

DTC P0451 EVAP CONTROL SYSTEM PRESSURE SENSOR

2. CHECK EVPA CONTROL SYSTEM PRESSURE SENSOR CONNECTOR FOR WATER

1. Disconnect EVAP control system pressure sensor harness connector.

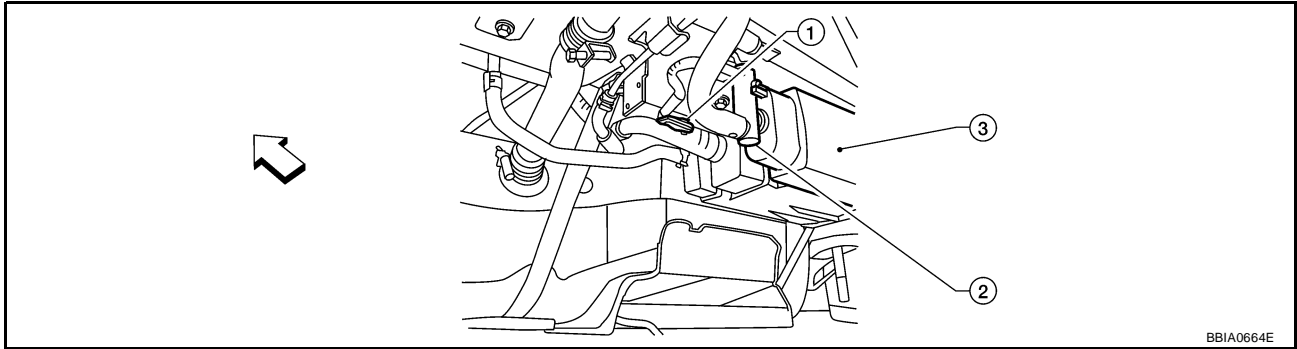

↔ Vehicle front

1. EVAP control system pressure sensor
2. EVAP canister vent control valve
3. EVAP canister

2. Check sensor harness connector for water.

Water should not exist.

OK or NG

- OK >> GO TO 3.
- NG >> Repair or replace harness connector.

3. CHECK EVAP CONTROL SYSTEM PRESSURE SENSOR

Refer to [EC-471, "Component Inspection"](#) .

OK or NG

- OK >> GO TO 4.
- NG >> Replace EVAP control system pressure sensor.

4. CHECK INTERMITTENT INCIDENT

Refer to [EC-149, "TROUBLE DIAGNOSIS FOR INTERMITTENT INCIDENT"](#) .

For Wiring Diagram, refer to [EC-474](#) .

>> INSPECTION END

Component Inspection EVAP CONTROL SYSTEM PRESSURE SENSOR

UBS00P9T

1. Remove EVAP control system pressure sensor with its harness connector connected from EVAP canister.
Always replace O-ring with a new one.
2. Install a vacuum pump to EVAP control system pressure sensor.
3. Turn ignition switch ON and check output voltage between ECM terminal 32 and ground under the following conditions.

Applied vacuum kPa (mmHg, inHg)	Voltage V
Not applied	1.8 - 4.8
-26.7 (-200, -7.87)	2.1 to 2.5V lower than above value

CAUTION:

- Always calibrate the vacuum pump gauge when using it.
- Do not apply below -93.3 kPa (-700 mmHg, -27.56 inHg) or pressure over 101.3 kPa (760 mmHg, 29.92 inHg).

4. If NG, replace EVAP control system pressure sensor.

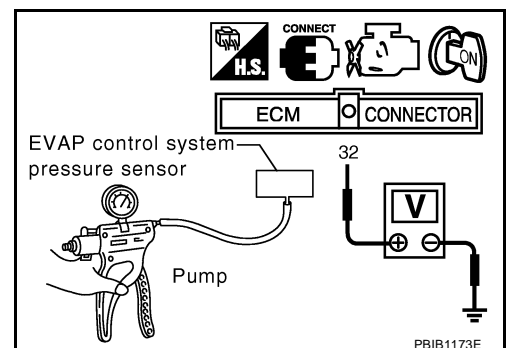

PBIB1173E

DTC P0452 EVAP CONTROL SYSTEM PRESSURE SENSOR

DTC P0452 EVAP CONTROL SYSTEM PRESSURE SENSOR

PF2:25085

Component Description

UBS00P9U

The EVAP control system pressure sensor detects pressure in the purge line. The sensor output voltage to the ECM increases as pressure increases.

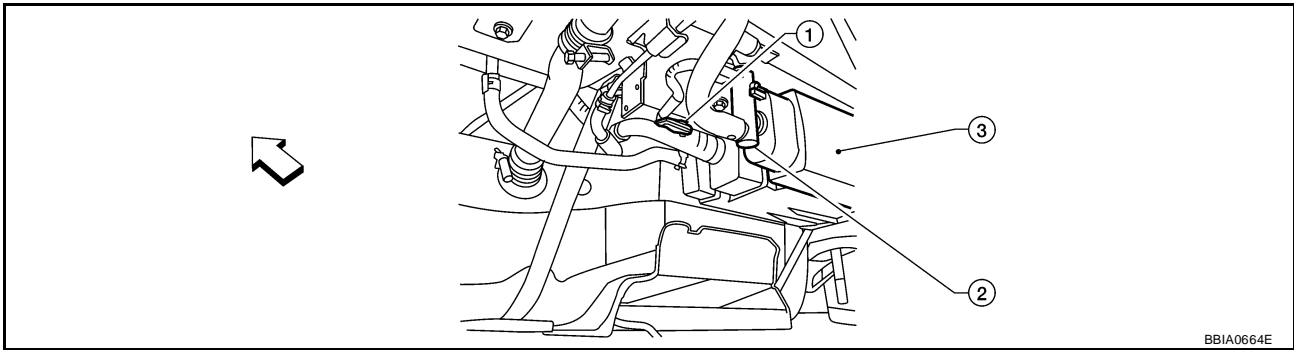
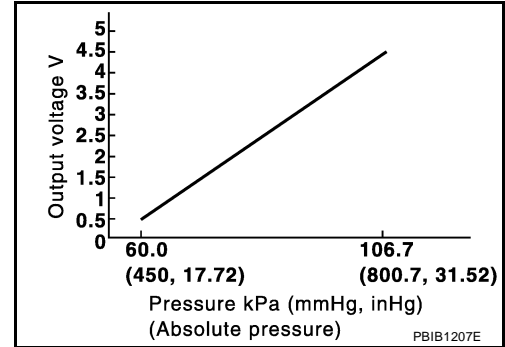

BBA0664E

← Vehicle front

1. EVAP control system pressure sensor 2. EVAP canister vent control valve 3. EVAP canister

CONSULT-II Reference Value in Data Monitor Mode

UBS00P9V

Specification data are reference values.

MONITOR ITEM	CONDITION	SPECIFICATION
EVAP SYS PRES	● Ignition switch: ON	Approx. 1.8 - 4.8V

On Board Diagnosis Logic

UBS00P9W

NOTE:

If DTC P0452 is displayed with DTC P0643, first perform the trouble diagnosis for DTC P0643. Refer to [EC-529, "DTC P0643 SENSOR POWER SUPPLY"](#).

DTC No.	Trouble diagnosis name	DTC detecting condition	Possible cause
P0452 0452	EVAP control system pressure sensor low input	An excessively low voltage from the sensor is sent to ECM.	<ul style="list-style-type: none"> ● Harness or connectors (The sensor circuit is open or shorted.) ● EVAP control system pressure sensor

DTC P0452 EVAP CONTROL SYSTEM PRESSURE SENSOR

UBS00P9X

DTC Confirmation Procedure

NOTE:

If DTC Confirmation Procedure has been previously conducted, always turn ignition switch OFF and wait at least 10 seconds before conducting the next test.

TESTING CONDITION:

Always perform test at a temperature of 5°C (41°F) or more.

WITH CONSULT-II

1. Start engine and warm it up to normal operating temperature.
2. Turn ignition switch OFF and wait at least 10 seconds.
3. Turn ignition switch ON.
4. Select "DATA MONITOR" mode with CONSULT-II.
5. Make sure that "FUEL T/TMP SE" is more than 0°C (32°F).
6. Start engine and wait at least 20 seconds.
If 1st trip DTC is detected, go to [EC-475, "Diagnostic Procedure"](#)

DATA MONITOR	
MONITOR	NO DTC
ENG SPEED	XXX rpm
COOLAN TEMP/S	XXX °C
FUEL T/TMP SE	XXX °C

SEF194Y

WITH GST

1. Start engine and warm it up to normal operating temperature.
2. Check that voltage between ECM terminal 107 (Fuel tank temperature sensor signal) and ground is less than 4.2V.
3. Turn ignition switch OFF and wait at least 10 seconds.
4. Start engine and wait at least 20 seconds.
5. Select Service \$07 with GST.
If 1st trip DTC is detected, go to [EC-475, "Diagnostic Procedure"](#)

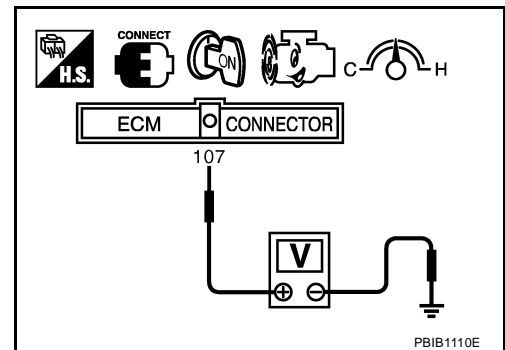

DTC P0452 EVAP CONTROL SYSTEM PRESSURE SENSOR

Wiring Diagram

UBS00P9Y

EC-PRE/SE-01

: DETECTABLE LINE FOR DTC
 : NON-DETECTABLE LINE FOR DTC

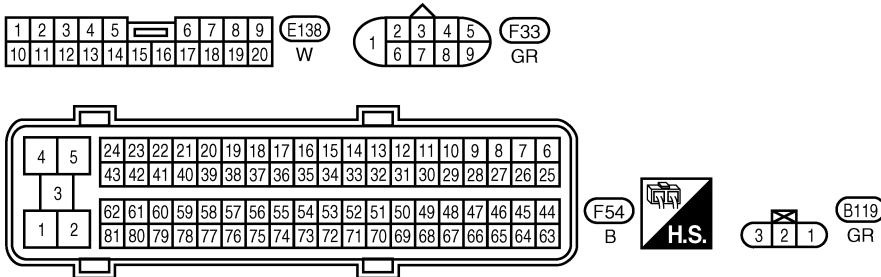
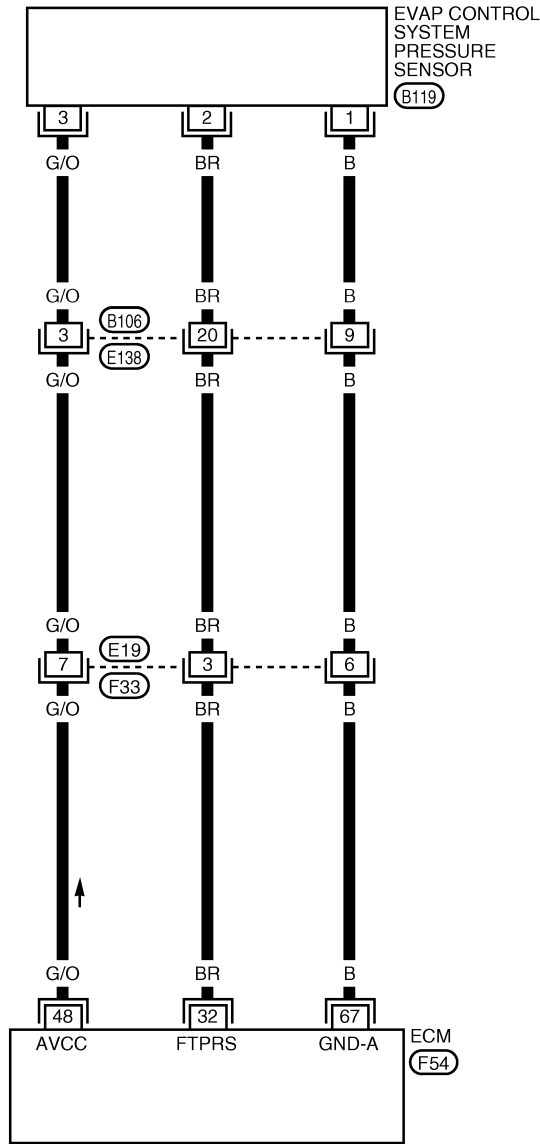

BBWA2522E

DTC P0452 EVAP CONTROL SYSTEM PRESSURE SENSOR

Specification data are reference values and are measured between each terminal and ground.

CAUTION:

Do not use ECM ground terminals when measuring input/output voltage. Doing so may result in damage to the ECM's transistor. Use a ground other than ECM terminals, such as the ground.

TERMINAL NO.	WIRE COLOR	ITEM	CONDITION	DATA (DC Voltage)
32	BR	EVAP control system pressure sensor	[Ignition switch: ON]	Approximately 1.8 - 4.8V
48	G/O	EVAP control system pressure sensor power supply	[Ignition switch: ON]	Approximately 5V
67	B	Sensor ground	[Engine is running] ● Warm-up condition ● Idle speed	Approximately 0V

Diagnostic Procedure

UBS00P9Z

1. CHECK GROUND CONNECTIONS

1. Turn ignition switch OFF.
2. Loosen and retighten three ground screws on the body. Refer to [EC-158, "Ground Inspection"](#).

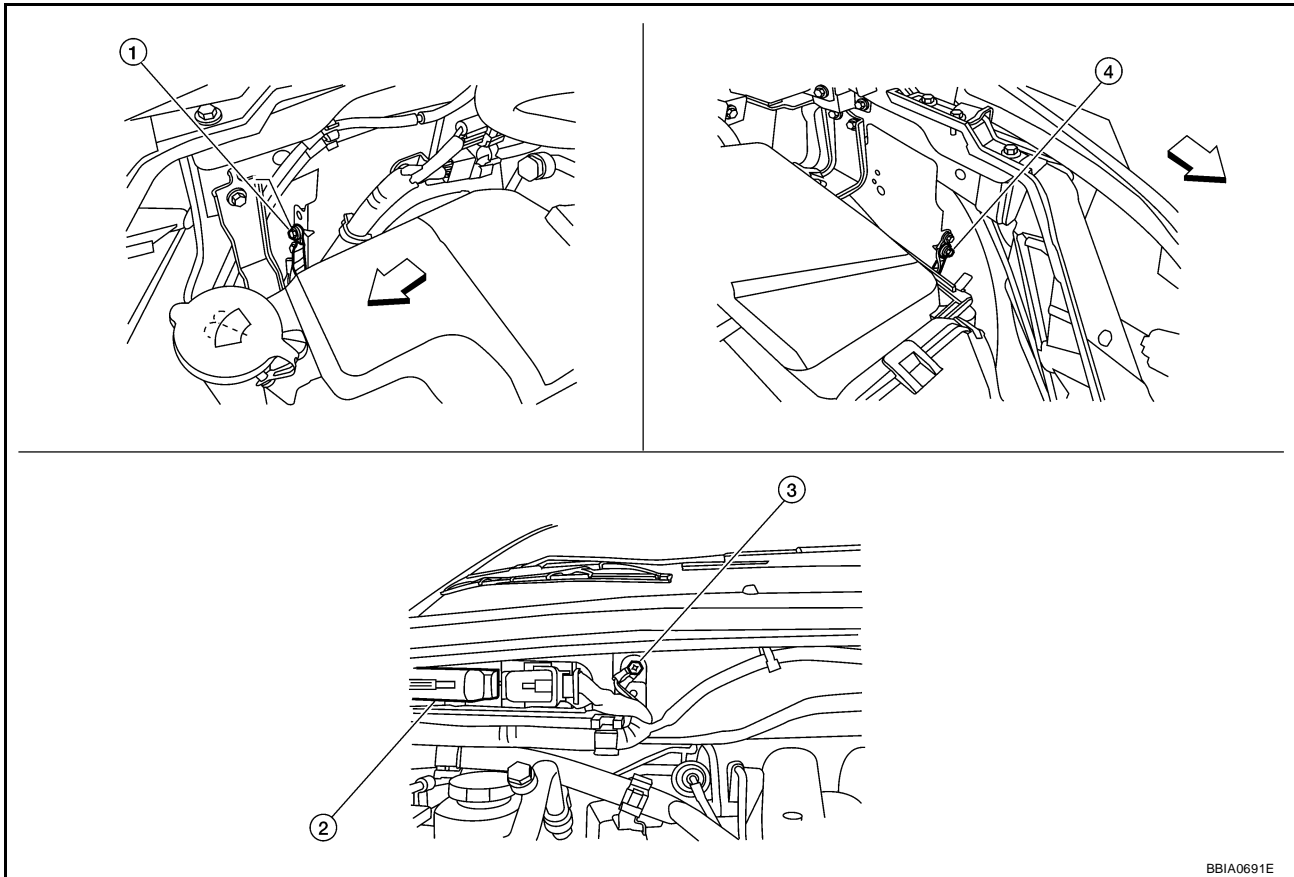

← Vehicle front

1. Body ground E24

2. ECM

3. Body ground E9

4. Body ground E15

OK or NG

OK >> GO TO 2.

NG >> Repair or replace ground connections.

DTC P0452 EVAP CONTROL SYSTEM PRESSURE SENSOR

2. CHECK CONNECTOR

1. Disconnect EVAP control system pressure sensor harness connector.

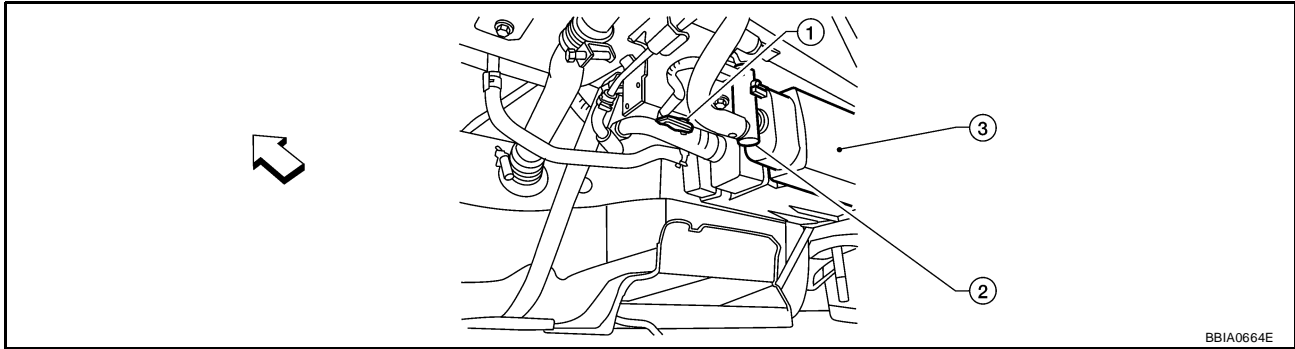

← Vehicle front

1. EVAP control system pressure sensor 2. EVAP canister vent control valve 3. EVAP canister

2. Check sensor harness connector for water.

Water should not exist.

OK or NG

- OK >> GO TO 3.
NG >> Repair or replace harness connector.

3. CHECK EVAP CONTROL SYSTEM PRESSURE SENSOR POWER SUPPLY CIRCUIT

1. Turn ignition switch ON.
2. Check voltage between EVAP control system pressure sensor terminal 3 and ground with CONSULT-II or tester.

Voltage: Approximately 5V

OK or NG

- OK >> GO TO 5.
NG >> GO TO 4.

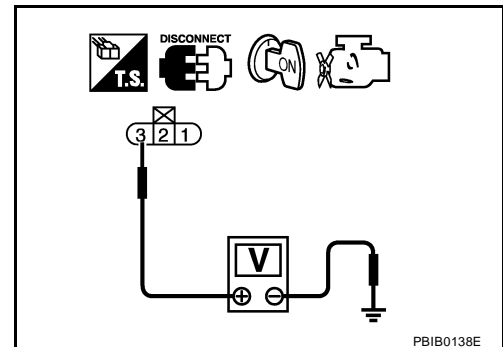

4. DETECT MALFUNCTIONING PART

Check the following.

- Harness connectors E19, F33
- Harness connectors B106, E138
- Harness for open or short between EVAP control system pressure sensor and ECM

>> Repair open circuit or short to ground or short to power in harness or connectors.

DTC P0452 EVAP CONTROL SYSTEM PRESSURE SENSOR

5. CHECK EVAP CONTROL SYSTEM PRESSURE SENSOR GROUND CIRCUIT FOR OPEN AND SHORT

1. Turn ignition switch OFF.
2. Disconnect ECM harness connector.
3. Check harness continuity between EVAP control system pressure sensor terminal 1 and ECM terminal 67. Refer to Wiring Diagram.

Continuity should exist.

4. Also check harness for short to ground and short to power.

OK or NG

- OK >> GO TO 7.
- NG >> GO TO 6.

6. DETECT MALFUNCTIONING PART

Check the following.

- Harness connectors E19, F33
- Harness connectors B106, E138
- Harness for open or short between EVAP control system pressure sensor and ECM

>> Repair open circuit or short to ground or short to power in harness or connectors.

7. CHECK EVAP CONTROL SYSTEM PRESSURE SENSOR INPUT SIGNAL CIRCUIT FOR OPEN AND SHORT

1. Check harness continuity between ECM terminal 32 and EVAP control system pressure sensor terminal 2. Refer to Wiring Diagram.

Continuity should exist.

2. Also check harness for short to ground and short to power.

OK or NG

- OK >> GO TO 9.
- NG >> GO TO 8.

8. DETECT MALFUNCTIONING PART

Check the following.

- Harness connectors E19, F33
- Harness connectors B106, E138
- Harness for open or short between EVAP control system pressure sensor and ECM

>> Repair open circuit or short to ground or short to power in harness or connectors.

9. CHECK EVAP CONTROL SYSTEM PRESSURE SENSOR

Refer to [EC-478, "Component Inspection"](#) .

OK or NG

- OK >> GO TO 10.
- NG >> Replace EVAP control system pressure sensor.

10. CHECK INTERMITTENT INCIDENT

Refer to [EC-149, "TROUBLE DIAGNOSIS FOR INTERMITTENT INCIDENT"](#) .

>> **INSPECTION END**

DTC P0452 EVAP CONTROL SYSTEM PRESSURE SENSOR

UBS00PA0

Component Inspection

EVAP CONTROL SYSTEM PRESSURE SENSOR

1. Remove EVAP control system pressure sensor with its harness connector connected from EVAP canister.
Always replace O-ring with a new one.
2. Install a vacuum pump to EVAP control system pressure sensor.
3. Turn ignition switch ON and check output voltage between ECM terminal 32 and ground under the following conditions.

Applied vacuum kPa (mmHg, inHg)	Voltage V
Not applied	1.8 - 4.8
-26.7 (-200, -7.87)	2.1 to 2.5V lower than above value

CAUTION:

- Always calibrate the vacuum pump gauge when using it.
 - Do not apply below -93.3 kPa (-700 mmHg, -27.56 inHg) or pressure over 101.3 kPa (760 mmHg, 29.92 inHg).
4. If NG, replace EVAP control system pressure sensor.

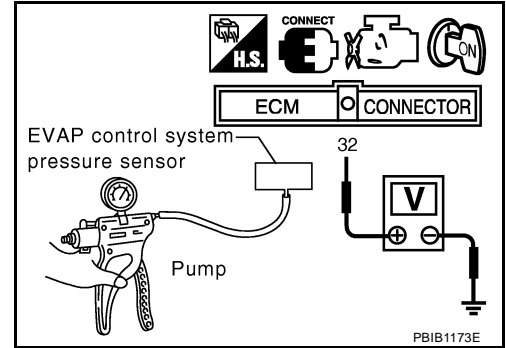

DTC P0453 EVAP CONTROL SYSTEM PRESSURE SENSOR

DTC P0453 EVAP CONTROL SYSTEM PRESSURE SENSOR

PDF:25085

Component Description

UBS00PA1

The EVAP control system pressure sensor detects pressure in the purge line. The sensor output voltage to the ECM increases as pressure increases.

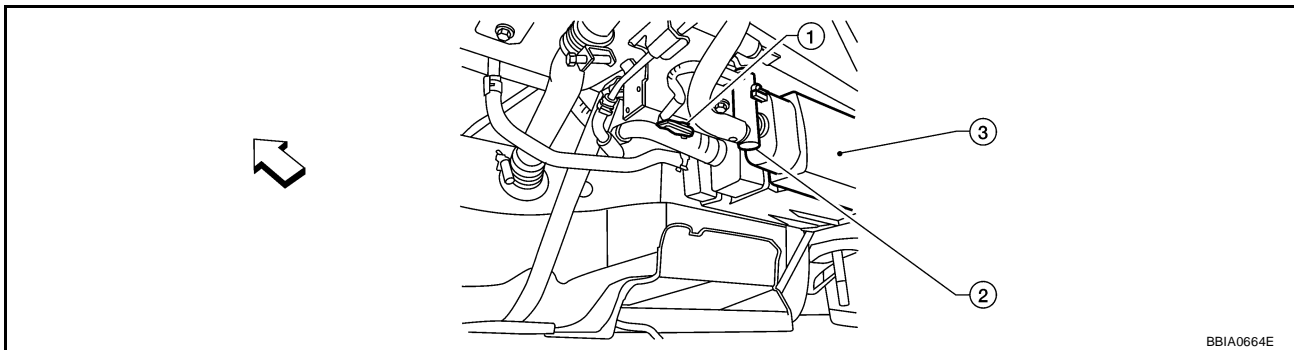
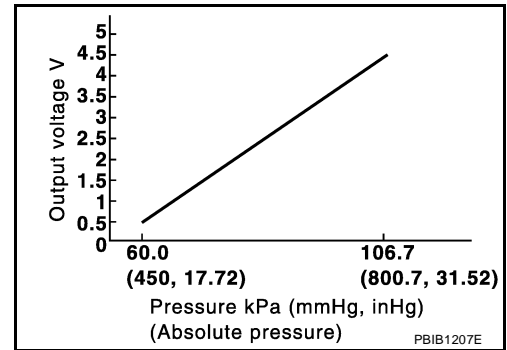

↔ Vehicle front

1. EVAP control system pressure sensor
2. EVAP canister vent control valve
3. EVAP canister

CONSULT-II Reference Value in Data Monitor Mode

UBS00PA2

Specification data are reference values.

MONITOR ITEM	CONDITION	SPECIFICATION
EVAP SYS PRES	● Ignition switch: ON	Approx. 1.8 - 4.8V

On Board Diagnosis Logic

UBS00PA3

NOTE:

If DTC P0453 is displayed with DTC P0643, first perform the trouble diagnosis for DTC P0643. Refer to [EC-529. "DTC P0643 SENSOR POWER SUPPLY"](#).

DTC No.	Trouble diagnosis name	DTC detecting condition	Possible cause
P0453 0453	EVAP control system pressure sensor high input	An excessively high voltage from the sensor is sent to ECM.	<ul style="list-style-type: none"> ● Harness or connectors (The sensor circuit is open or shorted.) ● EVAP control system pressure sensor ● EVAP canister vent control valve ● EVAP canister ● Rubber hose from EVAP canister vent control valve to vehicle frame

DTC P0453 EVAP CONTROL SYSTEM PRESSURE SENSOR

UBS00PA4

DTC Confirmation Procedure

NOTE:

If DTC Confirmation Procedure has been previously conducted, always turn ignition switch OFF and wait at least 10 seconds before conducting the next test.

TESTING CONDITION:

Always perform test at a temperature of 5°C (41°F) or more.

WITH CONSULT-II

1. Start engine and warm it up to normal operating temperature.
2. Turn ignition switch OFF and wait at least 10 seconds.
3. Turn ignition switch ON.
4. Select "DATA MONITOR" mode with CONSULT-II.
5. Make sure that "FUEL T/TMP SE" is more than 0°C (32°F).
6. Start engine and wait at least 10 seconds.
7. If 1st trip DTC is detected, go to [EC-482, "Diagnostic Procedure"](#)

DATA MONITOR	
MONITOR	NO DTC
ENG SPEED	XXX rpm
COOLAN TEMP/S	XXX °C
FUEL T/TMP SE	XXX °C

SEF194Y

WITH GST

1. Start engine and warm it up to normal operating temperature.
2. Check that voltage between ECM terminal 107 (Fuel tank temperature sensor signal) and ground is less than 4.2V.
3. Turn ignition switch OFF and wait at least 10 seconds.
4. Start engine wait at least 10 seconds.
5. Select Service \$07 with GST.
If 1st trip DTC is detected, go to [EC-482, "Diagnostic Procedure"](#)

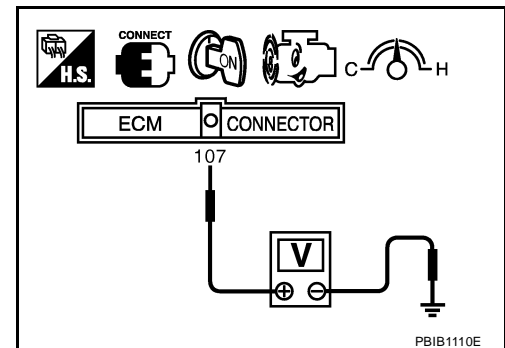

DTC P0453 EVAP CONTROL SYSTEM PRESSURE SENSOR

Wiring Diagram

UBS00PA5

EC-PRE/SE-01

: DETECTABLE LINE FOR DTC
 : NON-DETECTABLE LINE FOR DTC

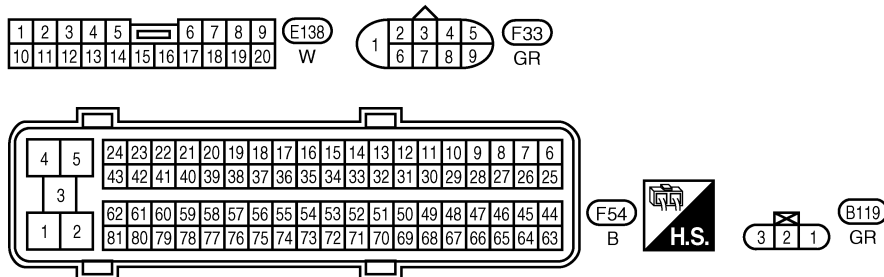
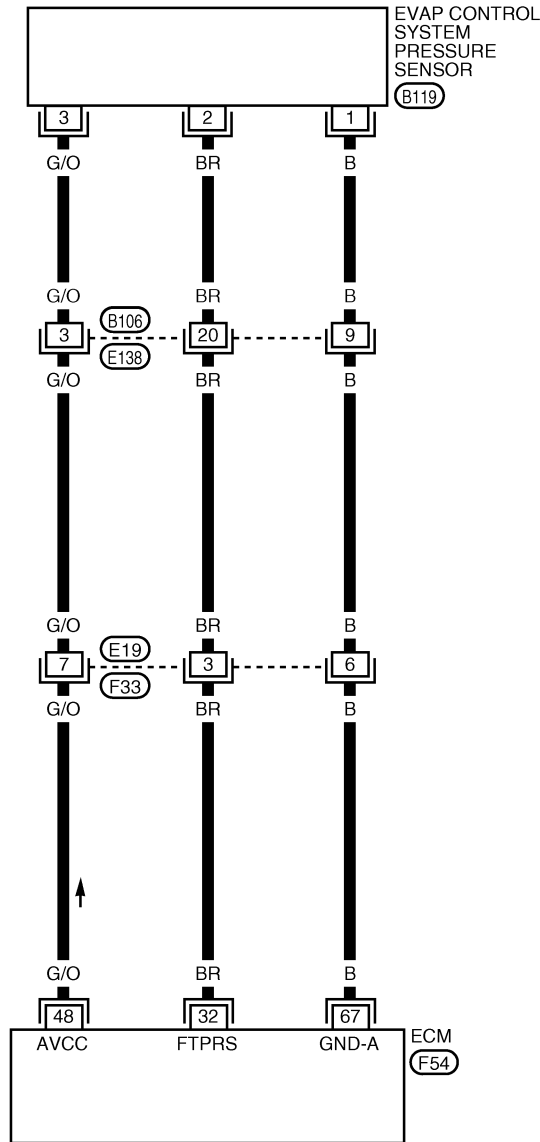

BBWA2522E

DTC P0453 EVAP CONTROL SYSTEM PRESSURE SENSOR

Specification data are reference values and are measured between each terminal and ground.

CAUTION:

Do not use ECM ground terminals when measuring input/output voltage. Doing so may result in damage to the ECM's transistor. Use a ground other than ECM terminals, such as the ground.

TER-MINAL NO.	WIRE COLOR	ITEM	CONDITION	DATA (DC Voltage)
32	BR	EVAP control system pressure sensor	[Ignition switch: ON]	Approximately 1.8 - 4.8V
48	G/O	EVAP control system pressure sensor power supply	[Ignition switch: ON]	Approximately 5V
67	B	Sensor ground	[Engine is running] ● Warm-up condition ● Idle speed	Approximately 0V

Diagnostic Procedure

UBS00PA6

1. CHECK GROUND CONNECTIONS

1. Turn ignition switch OFF.
2. Loosen and retighten three ground screws on the body. Refer to [EC-158, "Ground Inspection"](#).

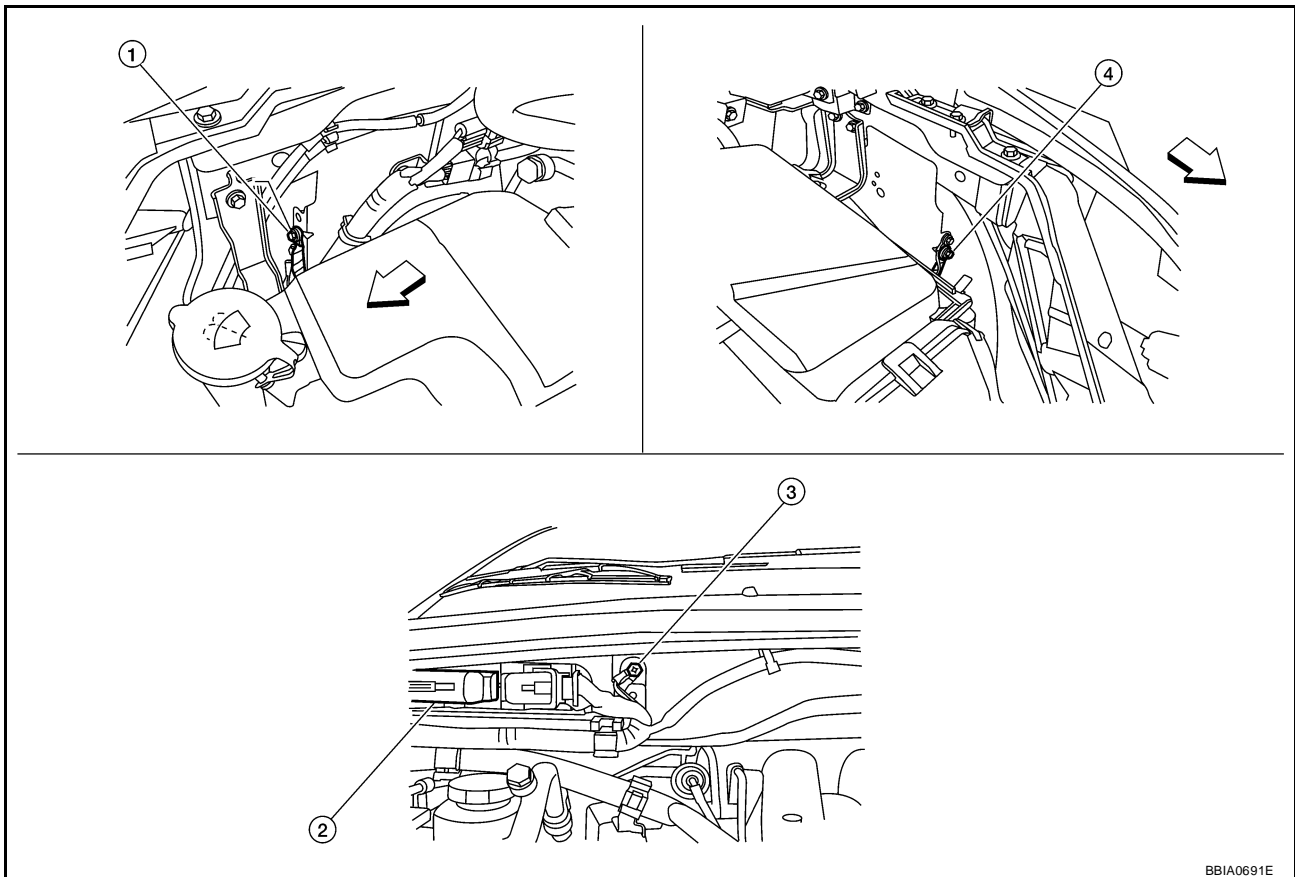

BBI A0691E

↔ Vehicle front

1. Body ground E24

2. ECM

3. Body ground E9

4. Body ground E15

OK or NG

OK >> GO TO 2.

NG >> Repair or replace ground connections.

DTC P0453 EVAP CONTROL SYSTEM PRESSURE SENSOR

2. CHECK CONNECTOR

1. Disconnect EVAP control system pressure sensor harness connector.

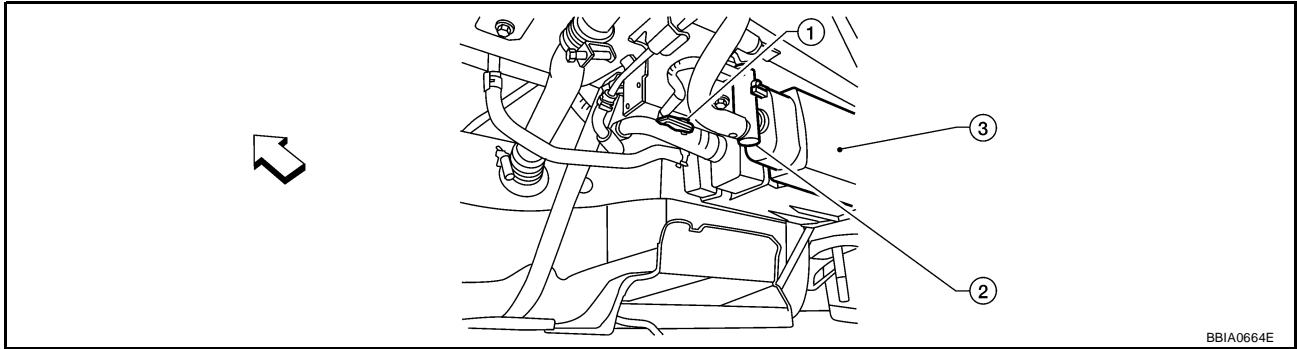

↔ Vehicle front

1. EVAP control system pressure sensor 2. EVAP canister vent control valve 3. EVAP canister

2. Check sensor harness connector for water.

Water should not exist.

OK or NG

- OK >> GO TO 3.
- NG >> Repair or replace harness connector.

3. CHECK EVAP CONTROL SYSTEM PRESSURE SENSOR POWER SUPPLY CIRCUIT

1. Turn ignition switch ON.
2. Check voltage between EVAP control system pressure sensor terminal 3 and ground with CONSULT-II or tester.

Voltage: Approximately 5V

OK or NG

- OK >> GO TO 5.
- NG >> GO TO 4.

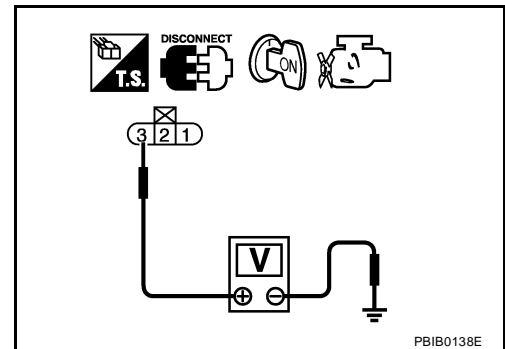

4. DETECT MALFUNCTIONING PART

Check the following.

- Harness connectors B106, E138
- Harness connectors E19, F33
- Harness for open or short between EVAP control system pressure sensor and ECM

>> Repair open circuit or short to ground or short to power in harness or connectors.

DTC P0453 EVAP CONTROL SYSTEM PRESSURE SENSOR

5. CHECK EVAP CONTROL SYSTEM PRESSURE SENSOR GROUND CIRCUIT FOR OPEN AND SHORT

1. Turn ignition switch OFF.
2. Disconnect ECM harness connector.
3. Check harness continuity between EVAP control system pressure sensor terminal 1 and ECM terminal 67. Refer to Wiring Diagram.

Continuity should exist.

4. Also check harness for short to ground and short to power.

OK or NG

- OK >> GO TO 7.
NG >> GO TO 6.

6. DETECT MALFUNCTIONING PART

Check the following.

- Harness connectors E19, F33
- Harness connectors B106, E138
- Harness for open or short between EVAP control system pressure sensor and ECM

>> Repair open circuit or short to ground or short to power in harness or connectors.

7. CHECK EVAP CONTROL SYSTEM PRESSURE SENSOR INPUT SIGNAL CIRCUIT FOR OPEN AND SHORT

1. Check harness continuity between ECM terminal 32 and EVAP control system pressure sensor terminal 2. Refer to Wiring Diagram.

Continuity should exist.

2. Also check harness for short to ground and short to power.

OK or NG

- OK >> GO TO 9.
NG >> GO TO 8.

8. DETECT MALFUNCTIONING PART

Check the following.

- Harness connectors E19, F33
- Harness connectors B106, E138
- Harness for open or short between EVAP control system pressure sensor and ECM

>> Repair open circuit or short to ground or short to power in harness or connectors.

9. CHECK RUBBER TUBE

1. Disconnect rubber tube connected to EVAP canister vent control valve.
2. Check the rubber tube for clogging, vent and kinked.

OK or NG

- OK >> GO TO 10.
NG >> Clean the rubber tube using an air blower, repair or replace rubber tube.

DTC P0453 EVAP CONTROL SYSTEM PRESSURE SENSOR

10. CHECK EVAP CANISTER VENT CONTROL VALVE

Refer to [EC-459, "Component Inspection"](#) .

OK or NG

- OK >> GO TO 11.
- NG >> Replace EVAP canister vent control valve.

11. CHECK EVAP CONTROL SYSTEM PRESSURE SENSOR

Refer to [EC-486, "Component Inspection"](#) .

OK or NG

- OK >> GO TO 12.
- NG >> Replace EVAP control system pressure sensor.

12. CHECK IF EVAP CANISTER SATURATED WITH WATER

1. Remove EVAP canister with EVAP canister vent control valve and EVAP control system pressure sensor attached.
2. Does water drain from the EVAP canister?.

Yes or No

- Yes >> GO TO 13.
- No >> GO TO 15.

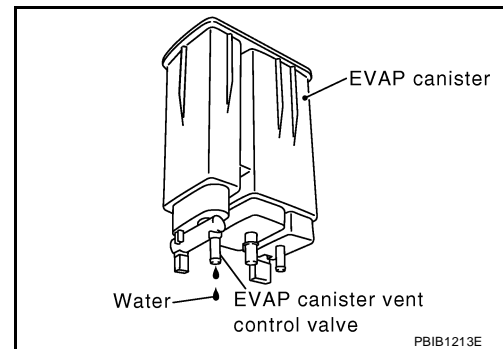

13. CHECK EVAP CANISTER

Weigh the EVAP canister with the EVAP canister vent control valve and EVAP control system pressure sensor attached.

The weight should be less than 2.1 kg (4.6 lb).

OK or NG

- OK >> GO TO 15.
- NG >> GO TO 14.

14. DETECT MALFUNCTIONING PART

Check the following.

- EVAP canister for damage
- EVAP hose between EVAP canister and vehicle frame for clogging or poor connection

>> Repair hose or replace EVAP canister.

15. CHECK INTERMITTENT INCIDENT

Refer to [EC-149, "TROUBLE DIAGNOSIS FOR INTERMITTENT INCIDENT"](#) .

>> INSPECTION END

DTC P0453 EVAP CONTROL SYSTEM PRESSURE SENSOR

UBS00PA7

Component Inspection

EVAP CONTROL SYSTEM PRESSURE SENSOR

1. Remove EVAP control system pressure sensor with its harness connector connected from EVAP canister.
Always replace O-ring, replace it with a new one.
2. Install a vacuum pump to EVAP control system pressure sensor.
3. Turn ignition switch ON and check output voltage between ECM terminal 32 and ground under the following conditions.

Applied vacuum kPa (mmHg, inHg)	Voltage V
Not applied	1.8 - 4.8
-26.7 (-200, -7.87)	2.1 to 2.5V lower than above value

CAUTION:

- Always calibrate the vacuum pump gauge when using it.
 - Do not apply below -93.3 kPa (-700 mmHg, -27.56 inHg) or pressure over 101.3 kPa (760 mmHg, 29.92 inHg).
4. If NG, replace EVAP control system pressure sensor.

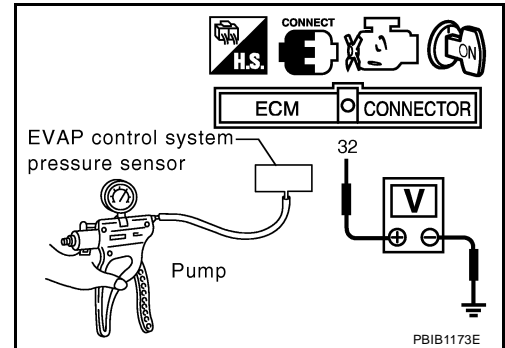

DTC P0455 EVAP CONTROL SYSTEM

DTC P0455 EVAP CONTROL SYSTEM

PF:14950

On Board Diagnosis Logic

UBS00PA8

This diagnosis detects a very large leak (fuel filler cap fell off etc.) in EVAP system between the fuel tank and EVAP canister purge volume control solenoid valve.

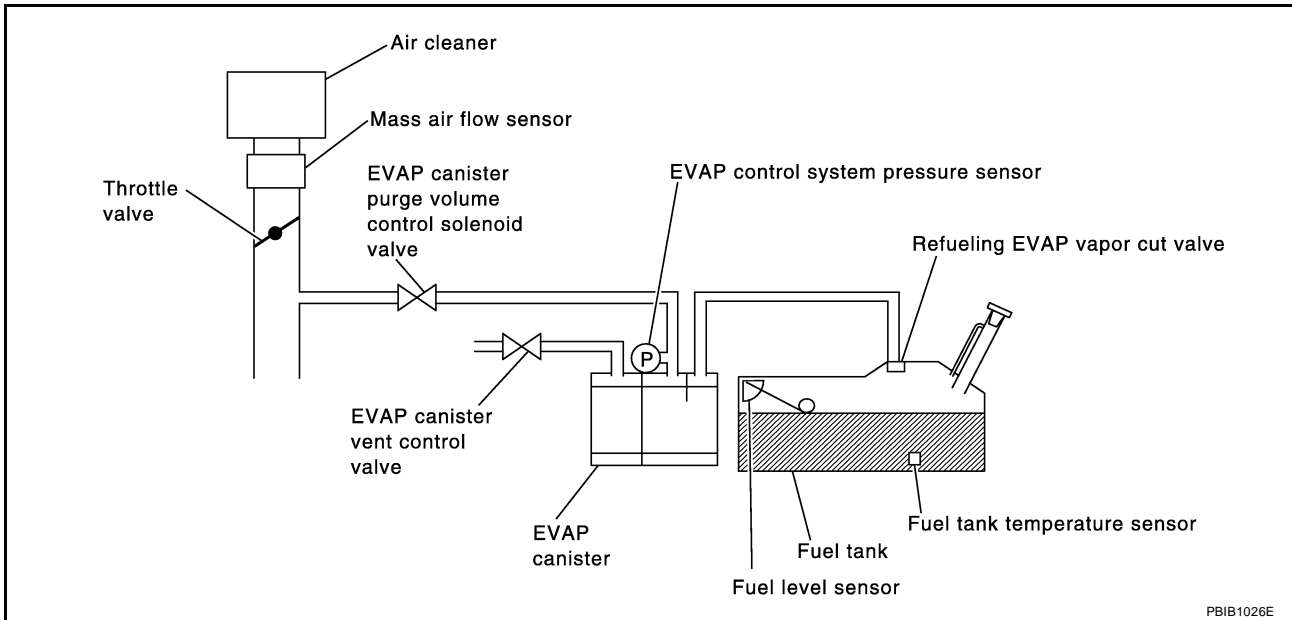

DTC No.	Trouble diagnosis name	DTC detecting condition	Possible cause
P0455 0455	EVAP control system gross leak detected	EVAP control system has a very large leak such as fuel filler cap fell off, EVAP control system does not operate properly.	<ul style="list-style-type: none"> ● Fuel filler cap remains open or fails to close. ● Incorrect fuel tank vacuum relief valve ● Incorrect fuel filler cap used ● Foreign matter caught in fuel filler cap. ● Leak is in line between intake manifold and EVAP canister purge volume control solenoid valve. ● Foreign matter caught in EVAP canister vent control valve. ● EVAP canister or fuel tank leaks ● EVAP purge line (pipe and rubber tube) leaks ● EVAP purge line rubber tube bent. ● Loose or disconnected rubber tube ● EVAP canister vent control valve and the circuit ● EVAP canister purge volume control solenoid valve and the circuit ● Fuel tank temperature sensor ● O-ring of EVAP canister vent control valve is missing or damaged. ● EVAP control system pressure sensor ● Refueling EVAP vapor cut valve ● ORVR system leaks

CAUTION:

- Use only a genuine NISSAN fuel filler cap as a replacement. If an incorrect fuel filler cap is used, the MIL may come on.
- If the fuel filler cap is not tightened properly, the MIL may come on.
- Use only a genuine NISSAN rubber tube as a replacement.

DTC P0455 EVAP CONTROL SYSTEM

UBS00PA9

DTC Confirmation Procedure

CAUTION:

Never remove fuel filler cap during the DTC Confirmation Procedure.

NOTE:

- Make sure that EVAP hoses are connected to EVAP canister purge volume control solenoid valve properly.
- If DTC Confirmation Procedure has been previously conducted, always turn ignition switch OFF and wait at least 10 seconds before conducting the next test.

TESTING CONDITION:

- Perform “DTC WORK SUPPORT” when the fuel level is between 1/4 and 3/4 full, and vehicle is placed on flat level surface.
- Open engine hood before conducting the following procedures.

WITH CONSULT-II

1. Tighten fuel filler cap securely until ratcheting sound is heard.
2. Turn ignition switch ON.
3. Turn ignition switch OFF and wait at least 10 seconds.
4. Turn ignition switch ON and select “DATA MONITOR” mode with CONSULT-II.
5. Make sure that the following conditions are met.
COOLAN TEMP/S: 0 - 70°C (32 - 158°F)
INT/A TEMP SE: 0 - 60°C (32 - 140°F)
6. Select “EVAP SML LEAK P0442/P1442” of “EVAPORATIVE SYSTEM” in “DTC WORK SUPPORT” mode with CONSULT-II.
Follow the instruction displayed.

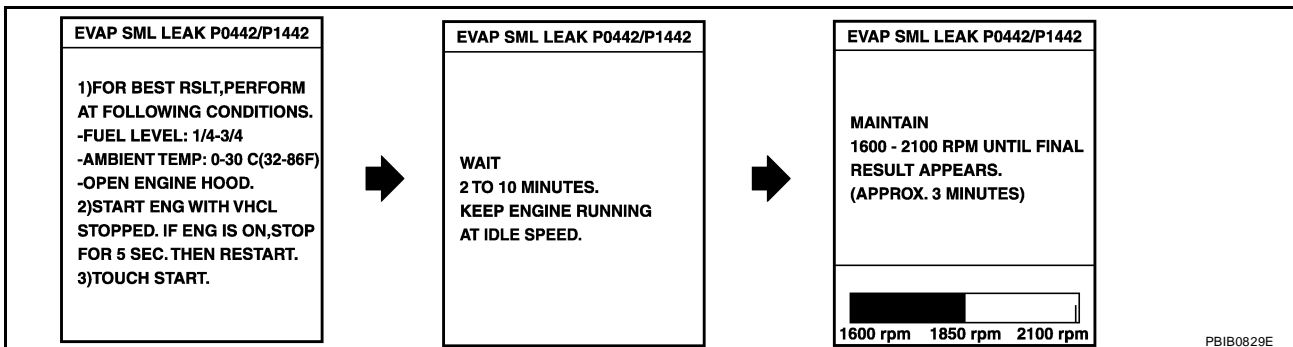

NOTE:

If the engine speed cannot be maintained within the range displayed on the CONSULT-II screen, go to [EC-73, "Basic Inspection"](#).

7. Make sure that “OK” is displayed.
If “NG” is displayed, select “SELF-DIAG RESULTS” mode and make sure that “EVAP GROSS LEAK [P0455]” is displayed. If it is displayed, refer to [EC-489, "Diagnostic Procedure"](#).
If P0442 is displayed, perform Diagnostic Procedure for DTC P0442, [EC-433, "Diagnostic Procedure"](#).

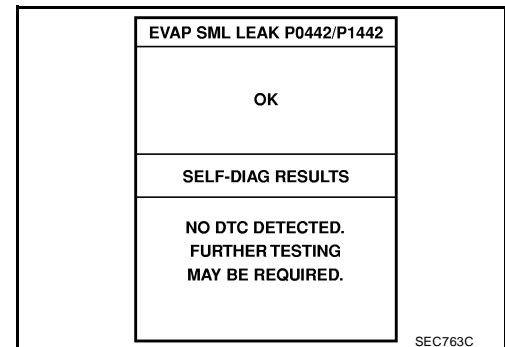

DTC P0455 EVAP CONTROL SYSTEM

WITH GST

NOTE:

Be sure to read the explanation of Driving Pattern on [EC-59, "Driving Pattern"](#) before driving vehicle.

1. Start engine.
2. Drive vehicle according to Driving Pattern, [EC-59, "Driving Pattern"](#) .
3. Stop vehicle.
4. Turn ignition switch OFF, wait at least 10 seconds and then turn ON.
5. Select Service \$07 with GST.
 - If P0441 is displayed on the screen, go to [EC-427, "Diagnostic Procedure"](#) .
 - If P0442 is displayed on the screen, go to [EC-433, "Diagnostic Procedure"](#) .
 - If P0455 is displayed on the screen, go to [EC-489, "Diagnostic Procedure"](#) .

Diagnostic Procedure

UBS00PAA

1. CHECK FUEL FILLER CAP DESIGN

1. Turn ignition switch OFF.
2. Check for genuine NISSAN fuel filler cap design.

OK or NG

- OK >> GO TO 2.
NG >> Replace with genuine NISSAN fuel filler cap.

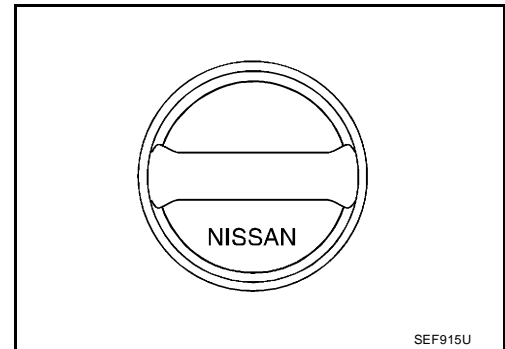

2. CHECK FUEL FILLER CAP INSTALLATION

Check that the cap is tightened properly by rotating the cap clockwise.

OK or NG

- OK >> GO TO 3.
NG >> 1. Open fuel filler cap, then clean cap and fuel filler neck threads using air blower.
2. Retighten until ratcheting sound is heard.

3. CHECK FUEL FILLER CAP FUNCTION

Check for air releasing sound while opening the fuel filler cap.

OK or NG

- OK >> GO TO 5.
NG >> GO TO 4.

4. CHECK FUEL TANK VACUUM RELIEF VALVE

Refer to [EC-35, "FUEL TANK VACUUM RELIEF VALVE \(BUILT INTO FUEL FILLER CAP\)"](#) .

OK or NG

- OK >> GO TO 5.
NG >> Replace fuel filler cap with a genuine one.

DTC P0455 EVAP CONTROL SYSTEM

5. CHECK EVAP PURGE LINE

Check EVAP purge line (pipe, rubber tube, fuel tank and EVAP canister) for cracks, improper connection or disconnection.

Refer to [EC-33, "EVAPORATIVE EMISSION LINE DRAWING"](#) .

OK or NG

OK >> GO TO 6.

NG >> Repair or reconnect the hose.

6. CLEAN EVAP PURGE LINE

Clean EVAP purge line (pipe and rubber tube) using air blower.

>> GO TO 7.

7. CHECK EVAP CANISTER VENT CONTROL VALVE

Check the following.

- EVAP canister vent control valve is installed properly.
Refer to [EC-36, "Removal and Installation"](#) .
- EVAP canister vent control valve.
Refer to [EC-459, "Component Inspection"](#) .

OK or NG

OK >> GO TO 8.

NG >> Repair or replace EVAP canister vent control valve and O-ring.

8. INSTALL THE PRESSURE PUMP

To locate the EVAP leak, install EVAP service port adapter and pressure pump to EVAP service port securely.

NOTE:

Improper installation of the EVAP service port adapter to the EVAP service port may cause leaking.

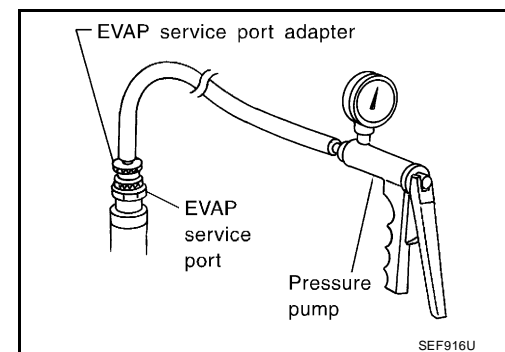
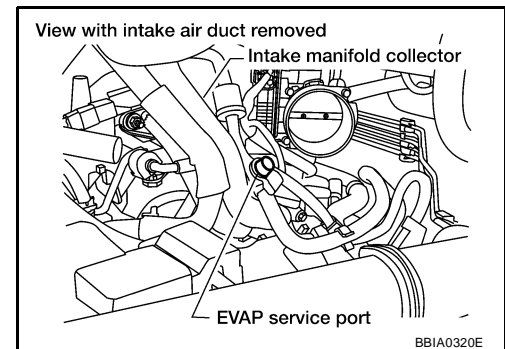

With CONSULT-II >>GO TO 9.

Without CONSULT-II>>GO TO 10.

DTC P0455 EVAP CONTROL SYSTEM

9. CHECK FOR EVAP LEAK

With CONSULT-II

1. Turn ignition switch ON.
2. Select "EVAP SYSTEM CLOSE" of "WORK SUPPORT" mode with CONSULT-II.
3. Touch "START" and apply pressure into the EVAP line until the pressure indicator reaches the middle of the bar graph.

CAUTION:

- Never use compressed air or a high pressure pump.
- Do not exceed 4.12 kPa (0.042 kg/cm² , 0.6 psi) of pressure in the system.

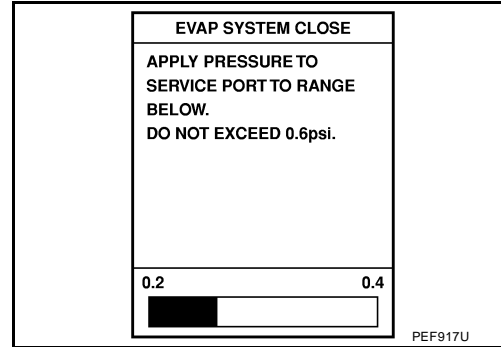

4. Using EVAP leak detector, locate the EVAP leak. For the leak detector, refer to the instruction manual for more details. Refer to [EC-33, "EVAPORATIVE EMISSION LINE DRAWING"](#) .

OK or NG

- OK >> GO TO 11.
NG >> Repair or replace.

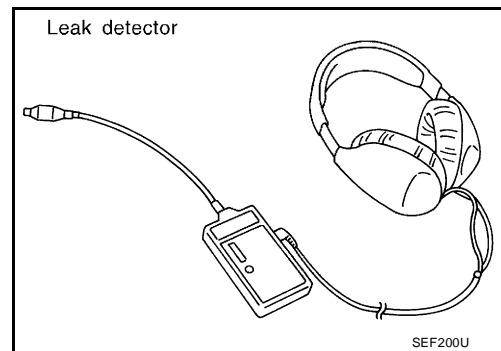

A
EC
C
D
E
F
G
H
I
J
K
L
M

DTC P0455 EVAP CONTROL SYSTEM

10. CHECK FOR EVAP LEAK

⊗ Without CONSULT-II

1. Turn ignition switch OFF.
2. Apply 12 volts DC to EVAP canister vent control valve. The valve will close. (Continue to apply 12 volts until the end of test.)

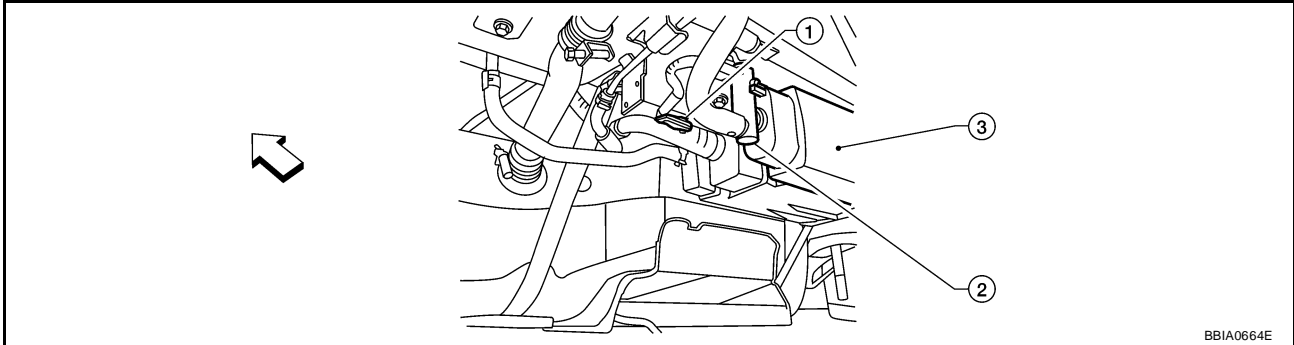

← Vehicle front

1. EVAP control system pressure sensor 2. EVAP canister vent control valve 3. EVAP canister

3. Pressurize the EVAP line using pressure pump with 1.3 to 2.7 kPa (10 to 20 mmHg, 0.39 to 0.79 inHg), then remove pump and EVAP service port adapter.

CAUTION:

- Never use compressed air or a high pressure pump.
- Do not exceed 4.12 kPa (0.042 kg/cm², 0.6 psi) of pressure in the system.

4. Using EVAP leak detector, locate the EVAP leak. For the leak detector, refer to the instruction manual for more details. Refer to [EC-33, "EVAPORATIVE EMISSION LINE DRAWING"](#).

OK or NG

- OK >> GO TO 12.
NG >> Repair or replace.

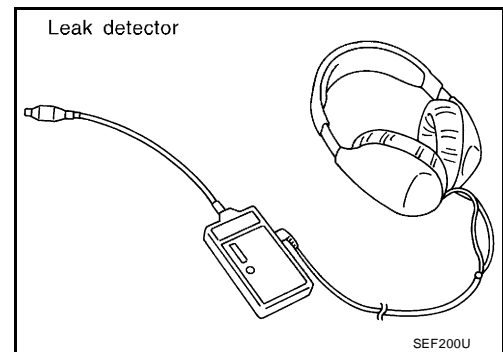

11. CHECK EVAP CANISTER PURGE VOLUME CONTROL SOLENOID VALVE OPERATION

Ⓟ With CONSULT-II

1. Disconnect vacuum hose to EVAP canister purge volume control solenoid valve at EVAP service port.
2. Start engine.
3. Perform "PURG VOL CONT/V" in "ACTIVE TEST" mode.
4. Touch "Qu" on CONSULT-II screen to increase "PURG VOL CONT/V" opening to 100%.
5. Check vacuum hose for vacuum when revving engine up to 2,000 rpm.

OK or NG

- OK >> GO TO 14.
NG >> GO TO 13.

ACTIVE TEST	
PURG VOL CONT/V	XXX %
MONITOR	
ENG SPEED	XXX rpm
A/F ALPHA-B1	XX %
A/F ALPHA-B2	XX %

PBIB1678E

DTC P0455 EVAP CONTROL SYSTEM

12. CHECK EVAP CANISTER PURGE VOLUME CONTROL SOLENOID VALVE OPERATION

⊗ Without CONSULT-II

1. Start engine and warm it up to normal operating temperature.
2. Stop engine.
3. Disconnect vacuum hose to EVAP canister purge volume control solenoid valve at EVAP service port.
4. Start engine and let it idle for at least 80 seconds.
5. Check vacuum hose for vacuum when revving engine up to 2,000 rpm.

Vacuum should exist.

OK or NG

- OK >> GO TO 15.
- NG >> GO TO 13.

13. CHECK VACUUM HOSE

Check vacuum hoses for clogging or disconnection. Refer to [EC-106, "Vacuum Hose Drawing"](#).

OK or NG

- OK (With CONSULT-II)>>GO TO 14.
- OK (Without CONSULT-II)>>GO TO 15.
- NG >> Repair or reconnect the hose.

14. CHECK EVAP CANISTER PURGE VOLUME CONTROL SOLENOID VALVE

Ⓜ With CONSULT-II

1. Start engine.
2. Perform "PURG VOL CONT/V" in "ACTIVE TEST" mode with CONSULT-II. Check that engine speed varies according to the valve opening.

OK or NG

- OK >> GO TO 16.
- NG >> GO TO 15.

ACTIVE TEST	
PURG VOL CONT/V	XXX %
MONITOR	
ENG SPEED	XXX rpm
A/F ALPHA-B1	XX %
A/F ALPHA-B2	XX %

PBIB1678E

15. CHECK EVAP CANISTER PURGE VOLUME CONTROL SOLENOID VALVE

Refer to [EC-452, "Component Inspection"](#).

OK or NG

- OK >> GO TO 16.
- NG >> Replace EVAP canister purge volume control solenoid valve.

16. CHECK FUEL TANK TEMPERATURE SENSOR

Refer to [EC-351, "Component Inspection"](#).

OK or NG

- OK >> GO TO 17.
- NG >> Replace fuel level sensor unit.

DTC P0455 EVAP CONTROL SYSTEM

17. CHECK EVAP CONTROL SYSTEM PRESSURE SENSOR

Refer to [EC-478, "Component Inspection"](#) .

OK or NG

OK >> GO TO 18.

NG >> Replace EVAP control system pressure sensor.

18. CHECK EVAP/ORVR LINE

Check EVAP/ORVR line between EVAP canister and fuel tank for clogging, kink, looseness and improper connection. For location, refer to [EC-39, "ON BOARD REFUELING VAPOR RECOVERY \(ORVR\)"](#) .

OK or NG

OK >> GO TO 19.

NG >> Repair or replace hoses and tubes.

19. CHECK RECIRCULATION LINE

Check recirculation line between filler neck tube and fuel tank for clogging, kink, cracks, looseness and improper connection.

OK or NG

OK >> GO TO 20.

NG >> Repair or replace hose, tube or filler neck tube.

20. CHECK REFUELING EVAP VAPOR CUT VALVE

Refer to [EC-43, "Component Inspection"](#) .

OK or NG

OK >> GO TO 21.

NG >> Replace refueling EVAP vapor cut valve with fuel tank.

21. CHECK INTERMITTENT INCIDENT

Refer to [EC-149, "TROUBLE DIAGNOSIS FOR INTERMITTENT INCIDENT"](#) .

>> **INSPECTION END**

DTC P0456 EVAP CONTROL SYSTEM

DTC P0456 EVAP CONTROL SYSTEM

PF1:14950

On Board Diagnosis Logic

UBS00PAB

This diagnosis detects very small leaks in the EVAP line between fuel tank and EVAP canister purge volume control solenoid valve, using the intake manifold vacuum in the same way as conventional EVAP small leak diagnosis.

If ECM judges a leak which corresponds to a very small leak, the very small leak P0456 will be detected.

If ECM judges a leak equivalent to a small leak, EVAP small leak P0442 will be detected.

If ECM judges there are no leaks, the diagnosis will be OK.

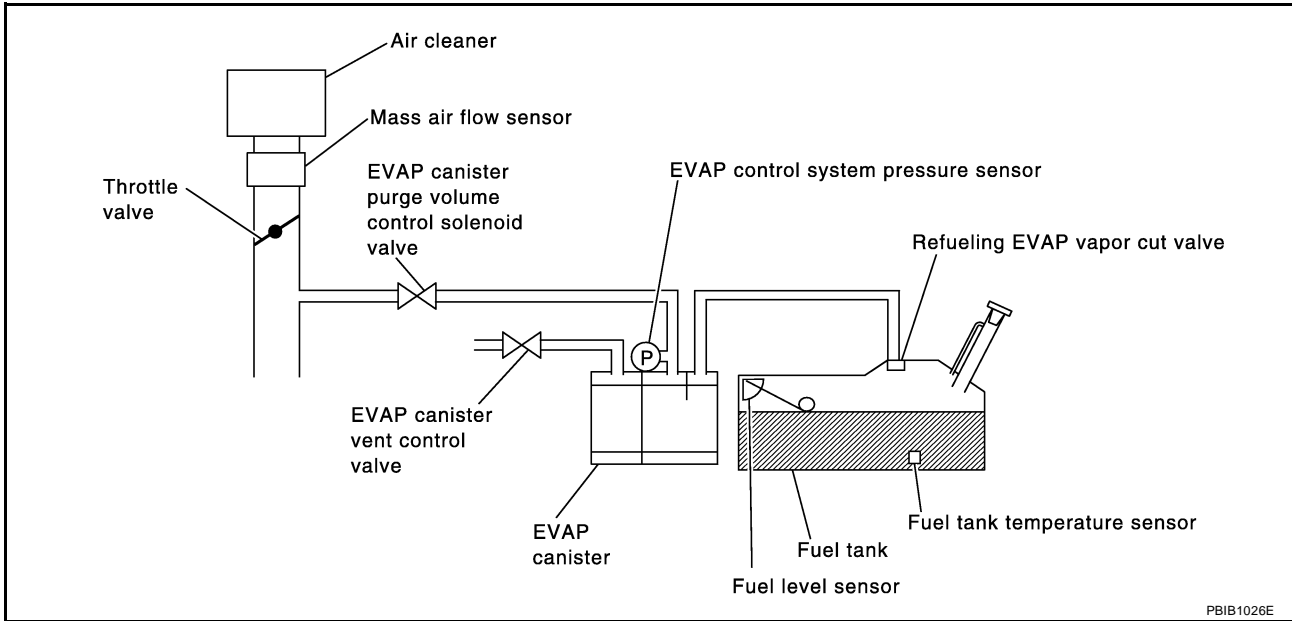

DTC No.	Trouble diagnosis name	DTC detecting condition	Possible cause
P0456 0456	Evaporative emission control system very small leak (negative pressure check)	<ul style="list-style-type: none"> ● EVAP system has a very small leak. ● EVAP system does not operate properly. 	<ul style="list-style-type: none"> ● Incorrect fuel tank vacuum relief valve ● Incorrect fuel filler cap used ● Fuel filler cap remains open or fails to close. ● Foreign matter caught in fuel filler cap. ● Leak is in line between intake manifold and EVAP canister purge volume control solenoid valve. ● Foreign matter caught in EVAP canister vent control valve. ● EVAP canister or fuel tank leaks ● EVAP purge line (pipe and rubber tube) leaks ● EVAP purge line rubber tube bent ● Loose or disconnected rubber tube ● EVAP canister vent control valve and the circuit ● EVAP canister purge volume control solenoid valve and the circuit ● Fuel tank temperature sensor ● O-ring of EVAP canister vent control valve is missing or damaged ● EVAP canister is saturated with water ● EVAP control system pressure sensor ● Refueling EVAP vapor cut valve ● ORVR system leaks ● Fuel level sensor and the circuit ● Foreign matter caught in EVAP canister purge volume control solenoid valve

DTC P0456 EVAP CONTROL SYSTEM

CAUTION:

- Use only a genuine NISSAN fuel filler cap as a replacement. If an incorrect fuel filler cap is used, the MIL may come on.
- If the fuel filler cap is not tightened properly, the MIL may come on.
- Use only a genuine NISSAN rubber tube as a replacement.

DTC Confirmation Procedure

UBS00PAC

NOTE:

- If DTC P0456 is displayed with P0442, first perform trouble diagnosis for DTC P0456.
- After repair, make sure that the hoses and clips are installed properly.
- If DTC Confirmation Procedure has been previously conducted, always turn ignition switch OFF and wait at least 10 seconds before conducting the next test.

TESTING CONDITION:

- Open engine hood before conducting following procedure.
- If any of following conditions are met just before the DTC confirmation procedure, leave the vehicle for more than 1 hour.
 - Fuel filler cap is removed.
 - Refilled or drained the fuel.
 - EVAP component parts is/are removed.
- Before performing the following procedure, confirm that battery voltage is more than 11V at idle.

WITH CONSULT-II

1. Turn ignition switch ON and select "DATA MONITOR" mode with CONSULT-II.
2. Make sure the following conditions are met.
FUEL LEVEL SE: 0.25 - 1.4V
COOLAN TEMP/S: 0 - 32°C (32 - 90°F)
FUEL T/TMP SE: 0 - 35°C (32 - 95°F)
INT/A TEMP SE: More than 0°C (32°F)
If NG, turn ignition switch OFF and leave the vehicle in a cool place (soak the vehicle) or refilling/draining fuel until the output voltage condition of the "FUEL LEVEL SE" meets within the range above and leave the vehicle for more than 1 hour. Then start from step 1).
3. Turn ignition switch OFF and wait at least 10 seconds.
4. Turn ignition switch ON.
5. Select "EVAP V/S LEAK P0456/P1456" of "EVAPORATIVE SYSTEM" in "DTC WORK SUPPORT" mode with CONSULT-II.
Follow the instruction displayed.

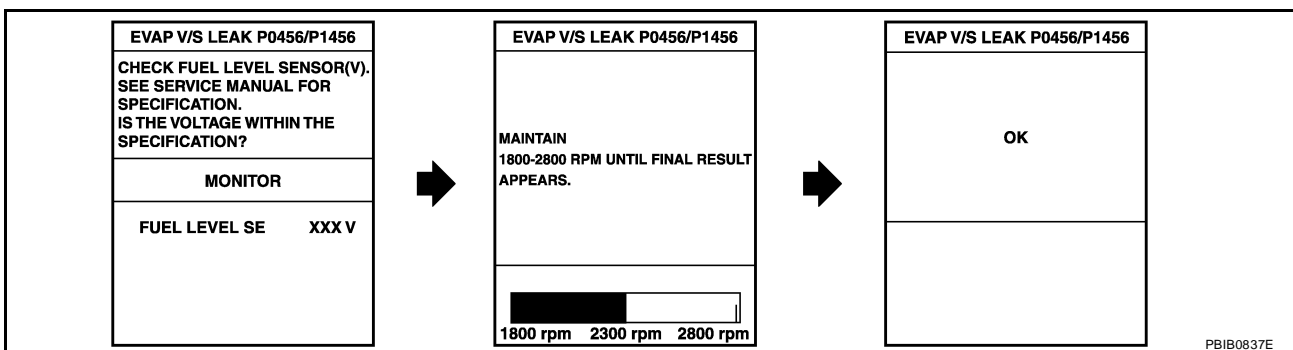

6. Make sure that "OK" is displayed.
If "NG" is displayed, refer to [EC-498, "Diagnostic Procedure"](#).

NOTE:

- If the engine speed cannot be maintained within the range displayed on CONSULT-II screen, go to [EC-73, "Basic Inspection"](#).
- Make sure that EVAP hoses are connected to EVAP canister purge volume control solenoid valve properly.

DTC P0456 EVAP CONTROL SYSTEM

UBS00PAD

Overall Function Check

WITH GST

Use this procedure to check the overall function of the EVAP very small leak function. During this check, a 1st trip DTC might not be confirmed.

CAUTION:

- Never use compressed air, doing so may damage the EVAP system.
- Do not start engine.
- Do not exceeded 4.12 kPa (0.042 kg/cm² , 0.6 psi).

1. Attach the EVAP service port adapter securely to the EVAP service port.

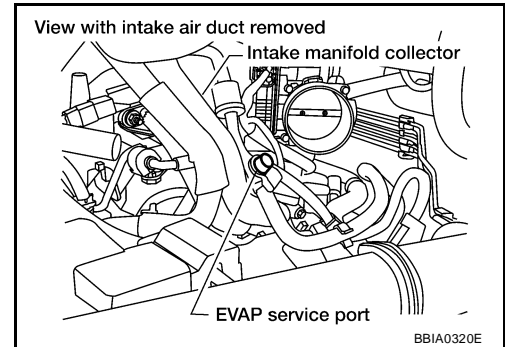

2. Set the pressure pump and a hose.
3. Also set a vacuum gauge via 3-way connector and a hose.
4. Turn ignition switch ON.
5. Connect GST and select Service \$08.
6. Using Service \$08 control the EVAP canister vent control valve (close).
7. Apply pressure and make sure the following conditions are satisfied.

Pressure to be applied: 2.7 kPa (20 mmHg, 0.79 inHg)

Time to be waited after the pressure drawn in to the EVAP system and the pressure to be dropped: 60 seconds and the pressure should not be dropped more than 0.4 kPa (3 mmHg, 0.12 inHg).

If NG, go to [EC-498, "Diagnostic Procedure"](#) .

If OK, go to next step.

8. Disconnect GST.
9. Start engine and warm it up to normal operating temperature.
10. Turn ignition switch OFF and wait at least 10 seconds.
11. Restart engine and let it idle for 90 seconds.
12. Keep engine speed at 2,000 rpm for 30 seconds.
13. Turn ignition switch OFF.

NOTE:

For more information, refer to GST instruction manual.

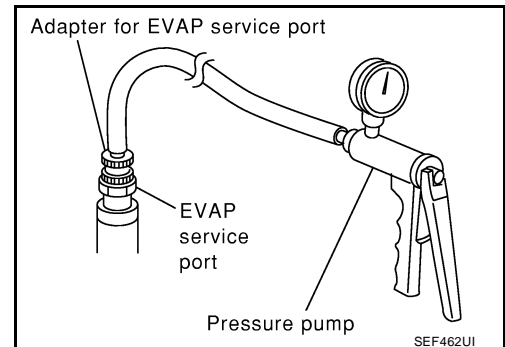

DTC P0456 EVAP CONTROL SYSTEM

UBS00PAE

Diagnostic Procedure

1. CHECK FUEL FILLER CAP DESIGN

1. Turn ignition switch OFF.
2. Check for genuine NISSAN fuel filler cap design.

OK or NG

- OK >> GO TO 2.
NG >> Replace with genuine NISSAN fuel filler cap.

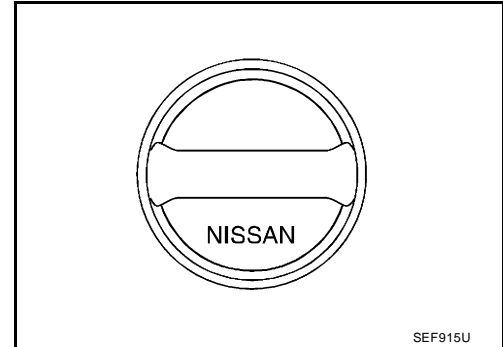

2. CHECK FUEL FILLER CAP INSTALLATION

Check that the cap is tightened properly by rotating the cap clockwise.

OK or NG

- OK >> GO TO 3.
NG >> 1. Open fuel filler cap, then clean cap and fuel filler neck threads using air blower.
2. Retighten until ratcheting sound is heard.

3. CHECK FUEL FILLER CAP FUNCTION

Check for air releasing sound while opening the fuel filler cap.

OK or NG

- OK >> GO TO 5.
NG >> GO TO 4.

4. CHECK FUEL TANK VACUUM RELIEF VALVE

Refer to [EC-35, "FUEL TANK VACUUM RELIEF VALVE \(BUILT INTO FUEL FILLER CAP\)"](#) .

OK or NG

- OK >> GO TO 5.
NG >> Replace fuel filler cap with a genuine one.

DTC P0456 EVAP CONTROL SYSTEM

5. INSTALL THE PRESSURE PUMP

To locate the EVAP leak, install EVAP service port adapter and pressure pump to EVAP service port securely.

NOTE:

Improper installation of the EVAP service port adapter to the EVAP service port may cause leaking.

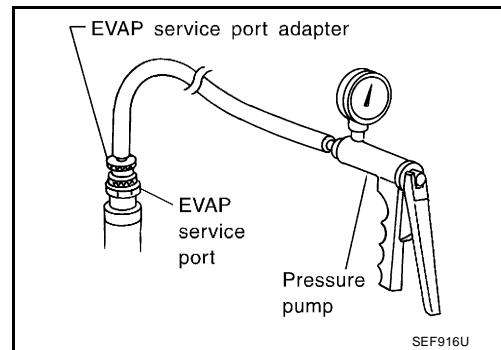
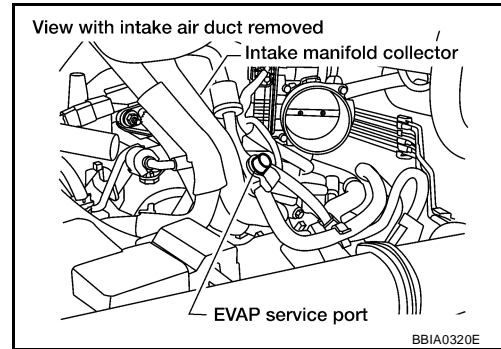

With CONSULT-II>>GO TO 6.
Without CONSULT-II>>GO TO 7.

6. CHECK FOR EVAP LEAK

With CONSULT-II

1. Turn ignition switch ON.
2. Select "EVAP SYSTEM CLOSE" of "WORK SUPPORT" mode with CONSULT-II.
3. Touch "START" and apply pressure into the EVAP line until the pressure indicator reaches the middle of the bar graph.

CAUTION:

- Never use compressed air or a high pressure pump.
- Do not exceed 4.12 kPa (0.042 kg/cm² , 0.6 psi) of pressure in the system.

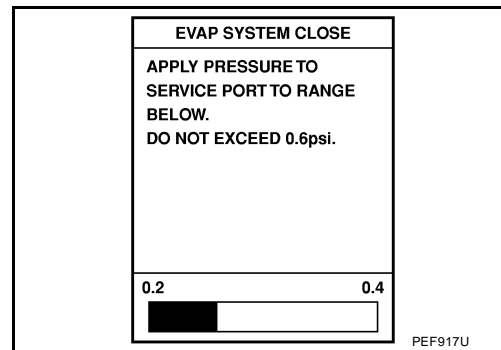

4. Using EVAP leak detector, locate the EVAP leak. For the leak detector, refer to the instruction manual for more details.
Refer to [EC-33, "EVAPORATIVE EMISSION LINE DRAWING"](#) .

OK or NG

- OK >> GO TO 8.
NG >> Repair or replace.

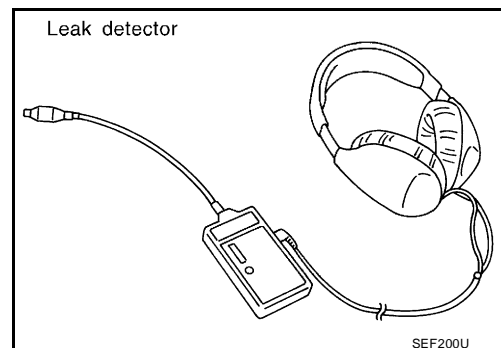

DTC P0456 EVAP CONTROL SYSTEM

7. CHECK FOR EVAP LEAK

⊗ Without CONSULT-II

1. Turn ignition switch OFF.
2. Apply 12 volts DC to EVAP canister vent control valve. The valve will close. (Continue to apply 12 volts until the end of test.)

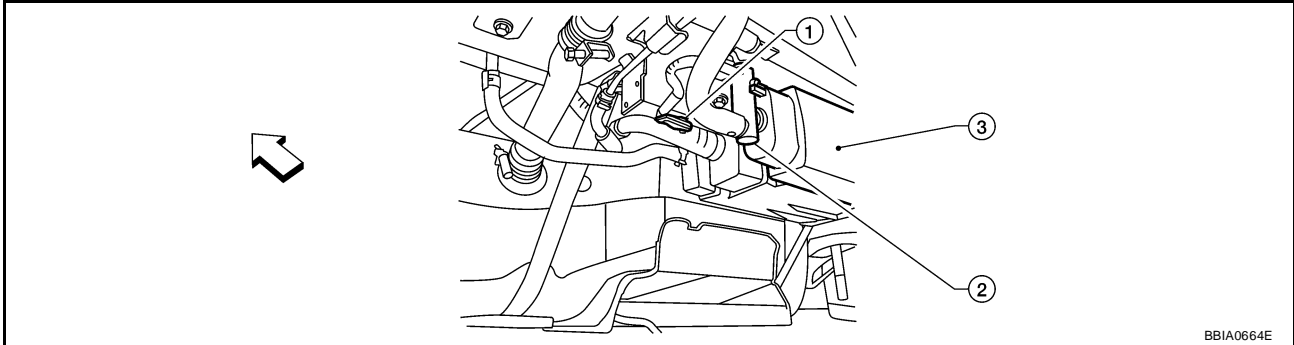

↔ Vehicle front

1. EVAP control system pressure sensor 2. EVAP canister vent control valve 3. EVAP canister

3. Pressurize the EVAP line using pressure pump with 1.3 to 2.7 kPa (10 to 20 mmHg, 0.39 to 0.79 inHg), then remove pump and EVAP service port adapter.

CAUTION:

- Never use compressed air or a high pressure pump.
- Do not exceed 4.12 kPa (0.042 kg/cm², 0.6 psi) of pressure in the system.

4. Using EVAP leak detector, locate the EVAP leak. For the leak detector, refer to the instruction manual for more details. Refer to [EC-33, "EVAPORATIVE EMISSION LINE DRAWING"](#).

OK or NG

- OK >> GO TO 8.
NG >> Repair or replace.

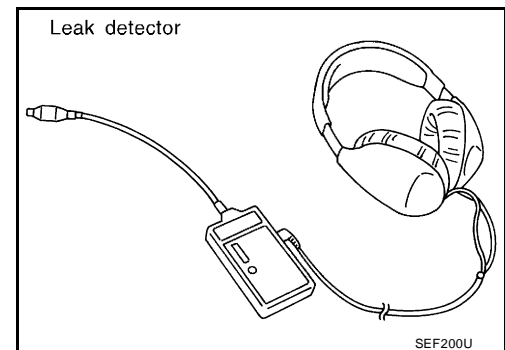

8. CHECK EVAP CANISTER VENT CONTROL VALVE

Check the following.

- EVAP canister vent control valve is installed properly. Refer to [EC-36, "Removal and Installation"](#).
- EVAP canister vent control valve. Refer to [EC-459, "Component Inspection"](#).

OK or NG

- OK >> GO TO 9.
NG >> Repair or replace EVAP canister vent control valve and O-ring.

DTC P0456 EVAP CONTROL SYSTEM

9. CHECK IF EVAP CANISTER SATURATED WITH WATER

1. Remove EVAP canister with EVAP canister vent control valve and EVAP control system pressure sensor attached.
2. Does water drain from the EVAP canister?

Yes or No

Yes >> GO TO 10.

No (With CONSULT-II)>>GO TO 12.

No (Without CONSULT-II)>>GO TO 13.

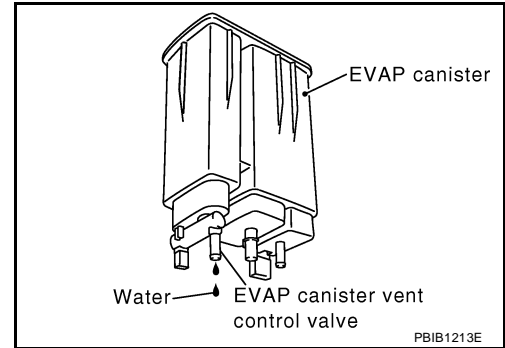

10. CHECK EVAP CANISTER

Weigh the EVAP canister with the EVAP canister vent control valve and EVAP control system pressure sensor attached.

The weight should be less than 2.1 kg (4.6 lb).

OK or NG

OK (With CONSULT-II)>>GO TO 12.

OK (Without CONSULT-II)>>GO TO 13.

NG >> GO TO 11.

11. DETECT MALFUNCTIONING PART

Check the following.

- EVAP canister for damage
- EVAP hose between EVAP canister and vehicle frame for clogging or poor connection

>> Repair hose or replace EVAP canister.

12. CHECK EVAP CANISTER PURGE VOLUME CONTROL SOLENOID VALVE OPERATION

Ⓜ With CONSULT-II

1. Disconnect vacuum hose to EVAP canister purge volume control solenoid valve at EVAP service port.
2. Start engine.
3. Perform "PURG VOL CONT/V" in "ACTIVE TEST" mode.
4. Touch "Qu" on CONSULT-II screen to increase "PURG VOL CONT/V" opening to 100%.
5. Check vacuum hose for vacuum when revving engine up to 2,000 rpm.

OK or NG

OK >> GO TO 15.

NG >> GO TO 14.

ACTIVE TEST	
PURG VOL CONT/V	XXX %
MONITOR	
ENG SPEED	XXX rpm
A/F ALPHA-B1	XX %
A/F ALPHA-B2	XX %

PBIB1678E

DTC P0456 EVAP CONTROL SYSTEM

13. CHECK EVAP CANISTER PURGE VOLUME CONTROL SOLENOID VALVE OPERATION

⊗ **Without CONSULT-II**

1. Start engine and warm it up to normal operating temperature.
2. Stop engine.
3. Disconnect vacuum hose to EVAP canister purge volume control solenoid valve at EVAP service port.
4. Start engine and let it idle for at least 80 seconds.
5. Check vacuum hose for vacuum when revving engine up to 2,000 rpm.

Vacuum should exist.

OK or NG

- OK >> GO TO 16.
NG >> GO TO 14.

14. CHECK VACUUM HOSE

Check vacuum hoses for clogging or disconnection. Refer to [EC-106, "Vacuum Hose Drawing"](#) .

OK or NG

- OK >> GO TO 15.
NG >> Repair or reconnect the hose.

15. CHECK EVAP CANISTER PURGE VOLUME CONTROL SOLENOID VALVE

Refer to [EC-452, "Component Inspection"](#) .

OK or NG

- OK >> GO TO 16.
NG >> Replace EVAP canister purge volume control solenoid valve.

16. CHECK FUEL TANK TEMPERATURE SENSOR

Refer to [EC-351, "Component Inspection"](#) .

OK or NG

- OK >> GO TO 17.
NG >> Replace fuel level sensor unit.

17. CHECK EVAP CONTROL SYSTEM PRESSURE SENSOR

Refer to [EC-478, "Component Inspection"](#) .

OK or NG

- OK >> GO TO 18.
NG >> Replace EVAP control system pressure sensor.

18. CHECK EVAP PURGE LINE

Check EVAP purge line (pipe, rubber tube, fuel tank and EVAP canister) for cracks or improper connection. Refer to [EC-33, "EVAPORATIVE EMISSION LINE DRAWING"](#) .

OK or NG

- OK >> GO TO 19.
NG >> Repair or reconnect the hose.

19. CLEAN EVAP PURGE LINE

Clean EVAP purge line (pipe and rubber tube) using air blower.

>> GO TO 20.

DTC P0456 EVAP CONTROL SYSTEM

20. CHECK EVAP/ORVR LINE

Check EVAP/ORVR line between EVAP canister and fuel tank for clogging, kink, looseness and improper connection. For location, refer to [EC-39, "ON BOARD REFUELING VAPOR RECOVERY \(ORVR\)"](#) .

OK or NG

OK >> GO TO 21.

NG >> Repair or replace hoses and tubes.

21. CHECK RECIRCULATION LINE

Check recirculation line between filler neck tube and fuel tank for clogging, kink, cracks, looseness and improper connection.

OK or NG

OK >> GO TO 22.

NG >> Repair or replace hose, tube or filler neck tube.

22. CHECK REFUELING EVAP VAPOR CUT VALVE

Refer to [EC-43, "Component Inspection"](#) .

OK or NG

OK >> GO TO 23.

NG >> Replace refueling EVAP vapor cut valve with fuel tank.

23. CHECK FUEL LEVEL SENSOR

Refer to [DI-22, "Fuel Level Sensor Unit Inspection"](#) .

OK or NG

OK >> GO TO 24.

NG >> Replace fuel level sensor unit.

24. CHECK INTERMITTENT INCIDENT

Refer to [EC-149, "TROUBLE DIAGNOSIS FOR INTERMITTENT INCIDENT"](#) .

>> INSPECTION END

A

EC

C

D

E

F

G

H

I

J

K

L

M

DTC P0460 FUEL LEVEL SENSOR

PF2:25060

DTC P0460 FUEL LEVEL SENSOR

UBS00PAF

Component Description

The fuel level sensor is mounted in the fuel level sensor unit. The sensor detects a fuel level in the fuel tank and transmits a signal to the combination meter. The combination meter sends the fuel level sensor signal to the ECM through CAN communication line. It consists of two parts, one is mechanical float and the other is variable resistor. Fuel level sensor output voltage changes depending on the movement of the fuel mechanical float.

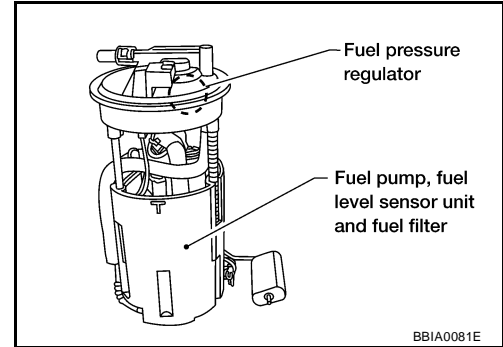

UBS00PAG

On Board Diagnosis Logic

NOTE:

- If DTC P0460 is displayed with DTC U1000 or U1001, first perform the trouble diagnosis for DTC U1000, U1001. Refer to [EC-159, "DTC U1000, U1001 CAN COMMUNICATION LINE"](#).
- If DTC P0460 is displayed with DTC U1010, first perform the trouble diagnosis for DTC U1010. Refer to [EC-162, "DTC U1010 CAN COMMUNICATION"](#).

When the vehicle is parked, naturally the fuel level in the fuel tank is stable. It means that output signal of the fuel level sensor does not change. If ECM senses sloshing signal from the sensor, fuel level sensor malfunction is detected.

DTC No.	Trouble diagnosis name	DTC detecting condition	Possible cause
P0460 0460	Fuel level sensor circuit noise	Even though the vehicle is parked, a signal being varied is sent from the fuel level sensor to ECM.	<ul style="list-style-type: none"> ● Harness or connectors (The CAN communication line is open or shorted) ● Harness or connectors (The sensor circuit is open or shorted) ● Combination meter ● Fuel level sensor

DTC Confirmation Procedure

UBS00PAH

NOTE:

If DTC Confirmation Procedure has been previously conducted, always turn ignition switch OFF and wait at least 10 seconds before conducting the next test.

④ WITH CONSULT-II

1. Turn ignition switch ON.
2. Select "DATA MONITOR" mode with CONSULT-II.
3. Start engine and wait maximum of 2 consecutive minutes.
4. If 1st trip DTC is detected, go to [EC-505, "Diagnostic Procedure"](#)

DATA MONITOR	
MONITOR	NO DTC
FUEL T/TMP SE	XXX °C
FUEL LEVEL SE	XXX V

SEP195Y

④ WITH GST

Follow the procedure "WITH CONSULT-II" above.

DTC P0460 FUEL LEVEL SENSOR

Diagnostic Procedure

UBS00PAI

1. CHECK FUEL GAUGE OPERATION

Refer to [DI-14, "Self-Diagnosis Mode of Combination Meter"](#) .

OK or NG

OK >> GO TO 2.

NG >> Follow the instruction of [DI-14, "Self-Diagnosis Mode of Combination Meter"](#) .

2. CHECK FUEL LEVEL SENSOR AND CIRCUIT

Refer to [DI-22, "Fuel Level Sensor Unit Inspection"](#) .

OK or NG

OK >> GO TO 3.

NG >> Repair or replace malfunctioning parts.

3. CHECK INTERMITTENT INCIDENT

Refer to [EC-149, "TROUBLE DIAGNOSIS FOR INTERMITTENT INCIDENT"](#) .

>> INSPECTION END

Removal and Installation FUEL LEVEL SENSOR

UBS00PAJ

Refer to [FL-5, "FUEL LEVEL SENSOR UNIT, FUEL FILTER AND FUEL PUMP ASSEMBLY"](#) .

A

EC

C

D

E

F

G

H

I

J

K

L

M

DTC P0461 FUEL LEVEL SENSOR

DTC P0461 FUEL LEVEL SENSOR

PF2:25060

Component Description

UBS00PAK

The fuel level sensor is mounted in the fuel level sensor unit. The sensor detects a fuel level in the fuel tank and transmits a signal to the combination meter. The combination meter sends the fuel level sensor signal to the ECM through CAN communication line. It consists of two parts, one is mechanical float and the other is variable resistor. Fuel level sensor output voltage changes depending on the movement of the fuel mechanical float.

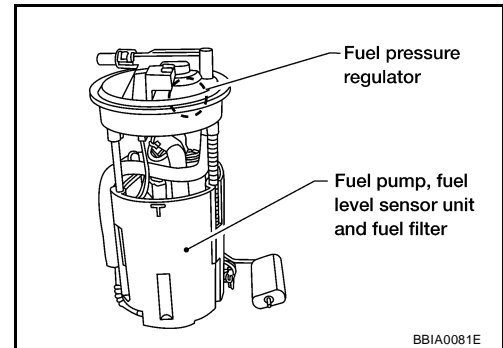

B8IA0081E

On Board Diagnosis Logic

UBS00PAL

NOTE:

- If DTC P0461 is displayed with DTC U1000 or U1001, first perform the trouble diagnosis for DTC U1000, U1001. Refer to [EC-159, "DTC U1000, U1001 CAN COMMUNICATION LINE"](#).
- If DTC P0461 is displayed with DTC U1010, first perform the trouble diagnosis for DTC U1010. Refer to [EC-162, "DTC U1010 CAN COMMUNICATION"](#).

Driving long distances naturally affect fuel gauge level.

This diagnosis detects the fuel gauge malfunction of the gauge not moving even after a long distance has been driven.

DTC No.	Trouble diagnosis name	DTC detecting condition	Possible cause
P0461 0461	Fuel level sensor circuit range/performance	The output signal of the fuel level sensor does not change within the specified range even though the vehicle has been driven a long distance.	<ul style="list-style-type: none"> ● Harness or connectors (The CAN communication line is open or shorted) ● Harness or connectors (The sensor circuit is open or shorted) ● Combination meter ● Fuel level sensor

Overall Function Check

UBS00PAM

Use this procedure to check the overall function of the fuel level sensor function. During this check, a 1st trip DTC might not be confirmed.

WARNING:

When performing following procedure, be sure to observe the handling of the fuel. Refer to [FL-9, "FUEL TANK"](#).

TESTING CONDITION:

Before starting overall function check, preparation of draining fuel and refilling fuel is required.

ⓐ WITH CONSULT-II

NOTE:

Start from step 10, if it is possible to confirm that the fuel cannot be drained by 30 ℓ (7-7/8 US gal, 6-5/8 Imp gal) in advance.

1. Prepare a fuel container and a spare hose.
2. Release fuel pressure from fuel line, refer to [EC-82, "FUEL PRESSURE RELEASE"](#).
3. Remove the fuel feed hose on the fuel level sensor unit.
4. Connect a spare fuel hose where the fuel feed hose was removed.
5. Turn ignition switch OFF and wait at least 10 seconds then turn ON.
6. Select "FUEL LEVEL SE" in "DATA MONITOR" mode with CONSULT-II.

DTC P0461 FUEL LEVEL SENSOR

7. Check "FUEL LEVEL SE" output voltage and note it.
8. Select "FUEL PUMP" in "ACTIVE TEST" mode with CONSULT-II.
9. Touch "ON" and drain fuel approximately 30 ℓ (7-7/8 US gal, 6-5/8 Imp gal) and stop it.
10. Check "FUEL LEVEL SE" output voltage and note it.
11. Fill fuel into the fuel tank for 30 ℓ (7-7/8 US gal, 6-5/8 Imp gal).
12. Check "FUEL LEVEL SE" output voltage and note it.
13. Confirm whether the voltage changes more than 0.03V during step 7 to 10 and 10 to 12.
If NG, go to [EC-507, "Diagnostic Procedure"](#) .

DATA MONITOR	
MONITOR	NO DTC
FUEL T/TMP SE	XXX °C
FUEL LEVEL SE	XXX V

SEF195Y

WITH GST

NOTE:

Start from step 8, if it is possible to confirm that the fuel cannot be drained by 30 ℓ (7-7/8 US gal, 6-5/8 Imp gal) in advance.

1. Prepare a fuel container and a spare hose.
2. Release fuel pressure from fuel line. Refer to [EC-82, "FUEL PRESSURE RELEASE"](#) .
3. Remove the fuel feed hose on the fuel level sensor unit.
4. Connect a spare fuel hose where the fuel feed hose was removed.
5. Turn ignition switch ON.
6. Drain fuel by 30 ℓ (7-7/8 US gal, 6-5/8 Imp gal) from the fuel tank using proper equipment.
7. Confirm that the fuel gauge indication varies.
8. Fill fuel into the fuel tank for 30 ℓ (7-7/8 US gal, 6-5/8 Imp gal).
9. Confirm that the fuel gauge indication varies.
10. If NG, go to [EC-507, "Diagnostic Procedure"](#) .

Diagnostic Procedure

1. CHECK FUEL GAUGE OPERATION

Refer to [DI-14, "Self-Diagnosis Mode of Combination Meter"](#) .

OK or NG

OK >> GO TO 2.

NG >> Follow the instruction of [DI-14, "Self-Diagnosis Mode of Combination Meter"](#) .

2. CHECK FUEL LEVEL SENSOR AND CIRCUIT

Refer to [DI-22, "Fuel Level Sensor Unit Inspection"](#) .

OK or NG

OK >> GO TO 3.

NG >> Repair or replace malfunctioning parts.

3. CHECK INTERMITTENT INCIDENT

Refer to [EC-149, "TROUBLE DIAGNOSIS FOR INTERMITTENT INCIDENT"](#) .

>> INSPECTION END

Removal and Installation FUEL LEVEL SENSOR

Refer to [FL-5, "FUEL LEVEL SENSOR UNIT, FUEL FILTER AND FUEL PUMP ASSEMBLY"](#) .

DTC P0462, P0463 FUEL LEVEL SENSOR

PF2:25060

DTC P0462, P0463 FUEL LEVEL SENSOR

Component Description

UBS00PAP

The fuel level sensor is mounted in the fuel level sensor unit. The sensor detects a fuel level in the fuel tank and transmits a signal to the combination meter. The combination meter sends the fuel level sensor signal to the ECM through CAN communication line. It consists of two parts, one is mechanical float and the other is variable resistor. Fuel level sensor output voltage changes depending on the movement of the fuel mechanical float.

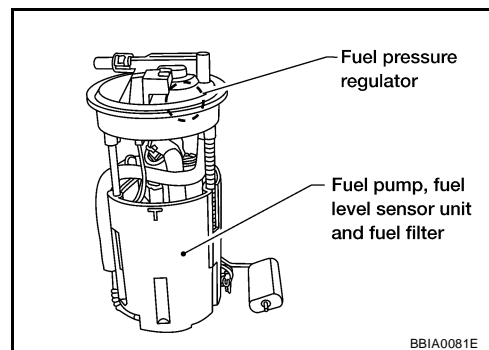

UBS00PAQ

On Board Diagnosis Logic

NOTE:

- If DTC P0462 or P0463 is displayed with DTC U1000 or U1001, first perform the trouble diagnosis for DTC U1000, U1001. Refer to [EC-159, "DTC U1000, U1001 CAN COMMUNICATION LINE"](#).
- If DTC P0462 is displayed with DTC U1010, first perform the trouble diagnosis for DTC U1010. Refer to [EC-162, "DTC U1010 CAN COMMUNICATION"](#).

This diagnosis indicates the former, to detect open or short circuit malfunction.

DTC No.	Trouble diagnosis name	DTC detecting condition	Possible cause
P0462 0462	Fuel level sensor circuit low input	An excessively low voltage is sent from the sensor is sent to ECM.	<ul style="list-style-type: none"> ● Harness or connectors (The CAN communication line is open or shorted) ● Harness or connectors (The sensor circuit is open or shorted) ● Combination meter ● Fuel level sensor
P0463 0463	Fuel level sensor circuit high input	An excessively high voltage is sent from the sensor is sent to ECM.	

DTC Confirmation Procedure

UBS00PAR

NOTE:

If DTC Confirmation Procedure has been previously conducted, always turn ignition switch OFF and wait at least 10 seconds before conducting the next test.

TESTING CONDITION:

Before performing the following procedure, confirm that battery voltage is more than 11V at ignition switch ON.

④ WITH CONSULT-II

1. Turn ignition switch ON.
2. Select "DATA MONITOR" mode with CONSULT-II.
3. Wait at least 5 seconds.
4. If 1st trip DTC is detected, go to [EC-509, "Diagnostic Procedure"](#)

DATA MONITOR	
MONITOR	NO DTC
FUEL T/TMP SE	XXX °C
FUEL LEVEL SE	XXX V

SEF195Y

④ WITH GST

Follow the procedure "WITH CONSULT-II" above.

DTC P0462, P0463 FUEL LEVEL SENSOR

Diagnostic Procedure

UBS00PAS

1. CHECK FUEL GAUGE OPERATION

Refer to [DI-14, "Self-Diagnosis Mode of Combination Meter"](#) .

OK or NG

OK >> GO TO 2.

NG >> Follow the instruction of [DI-14, "Self-Diagnosis Mode of Combination Meter"](#) .

2. CHECK FUEL LEVEL SENSOR AND CIRCUIT

Refer to [DI-22, "Fuel Level Sensor Unit Inspection"](#) .

OK or NG

OK >> GO TO 3.

NG >> Repair or replace malfunctioning parts.

3. CHECK INTERMITTENT INCIDENT

Refer to [EC-149, "TROUBLE DIAGNOSIS FOR INTERMITTENT INCIDENT"](#) .

>> INSPECTION END

Removal and Installation FUEL LEVEL SENSOR

UBS00PAT

Refer to [FL-5, "FUEL LEVEL SENSOR UNIT, FUEL FILTER AND FUEL PUMP ASSEMBLY"](#) .

A

EC

C

D

E

F

G

H

I

J

K

L

M

DTC P0500 VSS

PF:32702

DTC P0500 VSS

Description

UBS00PAU

NOTE:

- If DTC P0500 is displayed with DTC U1000 or U1001, first perform the trouble diagnosis for DTC U1000, U1001. Refer to [EC-159, "DTC U1000, U1001 CAN COMMUNICATION LINE"](#).
- If DTC P0500 is displayed with DTC U1010, first perform the trouble diagnosis for DTC U1010. Refer to [EC-162, "DTC U1010 CAN COMMUNICATION"](#).

The vehicle speed signal is sent to the combination meter from the "ABS actuator and electric unit (control unit)" by CAN communication line. The combination meter then sends the signal to the ECM by CAN communication line.

On Board Diagnosis Logic

UBS00PAV

DTC No.	Trouble diagnosis name	DTC detecting condition	Possible cause
P0500 0500	Vehicle speed sensor	The almost 0 km/h (0 MPH) signal from vehicle speed sensor is sent to ECM even when vehicle is being driven.	<ul style="list-style-type: none"> ● Harness or connectors (The CAN communication line is open or shorted) ● Harness or connectors (The vehicle speed signal circuit is open or shorted) ● Wheel sensor ● Combination meter ● ABS actuator and electric unit (control unit)

DTC Confirmation Procedure

UBS00PAW

CAUTION:

Always drive vehicle at a safe speed.

NOTE:

If DTC Confirmation Procedure has been previously conducted, always turn ignition switch OFF and wait at least 10 seconds before conducting the next test.

TESTING CONDITION:

Steps 1 and 2 may be conducted with the drive wheels lifted in the shop or by driving the vehicle. If a road test is expected to be easier, it is unnecessary to lift the vehicle.

WITH CONSULT-II

1. Start engine (TCS switch or VDC switch OFF).
2. Read "VHCL SPEED SE" in "DATA MONITOR" mode with CONSULT-II. The vehicle speed on CONSULT-II should exceed 10 km/h (6 MPH) when rotating wheels with suitable gear position.
If NG, go to [EC-511, "Diagnostic Procedure"](#).
If OK, go to following step.
3. Select "DATA MONITOR" mode with CONSULT-II.
4. Warm engine up to normal operating temperature.
5. Maintain the following conditions for at least 60 consecutive seconds.

ENG SPEED	1,600 - 6,000 rpm
COOLAN TEMP/S	More than 70°C (158°F)
B/FUEL SCHDL	4.4 - 31.8 msec
Shift lever	Except P or N position
PW/ST SIGNAL	OFF

6. If 1st trip DTC is detected, go to [EC-511, "Diagnostic Procedure"](#)

DATA MONITOR	
MONITOR	NO DTC
ENG SPEED	XXX rpm
COOLAN TEMP/S	XXX °C
B/FUEL SCHDL	XXX msec
PW/ST SIGNAL	OFF
VHCL SPEED SE	XXX km/h

SEF196Y

DTC P0500 VSS

Overall Function Check

UBS00PAX

Use this procedure to check the overall function of the vehicle speed sensor circuit. During this check, a 1st trip DTC might not be confirmed.

WITH GST

1. Lift up drive wheels.
2. Start engine.
3. Read vehicle speed sensor signal in Service \$01 with GST.
The vehicle speed sensor on GST should be able to exceed 10 km/h (6 MPH) when rotating wheels with suitable gear position.
4. If NG, go to [EC-511, "Diagnostic Procedure"](#) .

Diagnostic Procedure

UBS00PAY

1. CHECK DTC WITH "ABS ACTUATOR AND ELECTRIC UNIT (CONTROL UNIT)"

Refer to [BRC-55, "TROUBLE DIAGNOSIS"](#) (models with VDC) or [BRC-10, "TROUBLE DIAGNOSIS"](#) (models without VDC).

OK or NG

- OK >> GO TO 2.
- NG >> Repair or replace.

2. COMBINATION METER

Check combination meter function.
Refer to [DI-5, "COMBINATION METERS"](#) .

>> INSPECTION END

DTC P0506 ISC SYSTEM

DTC P0506 ISC SYSTEM

PF:23781

Description

UBS00PAZ

NOTE:

If DTC P0506 is displayed with other DTC, first perform the trouble diagnosis for the other DTC.

The ECM controls the engine idle speed to a specified level through the fine adjustment of the air, which is let into the intake manifold, by operating the electric throttle control actuator. The operating of the throttle valve is varied to allow for optimum control of the engine idling speed. The ECM calculates the actual engine speed from signals of crankshaft position sensor (POS) and camshaft position sensor (PHASE).

The ECM controls the electric throttle control actuator so that the engine speed coincides with the target value memorized in the ECM. The target engine speed is the lowest speed at which the engine can operate steadily. The optimum value stored in the ECM is determined by taking into consideration various engine conditions, such as during warming up, deceleration, and engine load (air conditioner, power steering and cooling fan operation, etc.).

On Board Diagnosis Logic

UBS00PB0

DTC No.	Trouble diagnosis name	DTC detecting condition	Possible cause
P0506 0506	Idle speed control system RPM lower than expected	The idle speed is less than the target idle speed by 100 rpm or more.	<ul style="list-style-type: none">● Electric throttle control actuator● Intake air leak

DTC Confirmation Procedure

UBS00PB1

NOTE:

- If DTC Confirmation Procedure has been previously conducted, always turn ignition switch OFF and wait at least 10 seconds before conducting the next test.
- If the target idle speed is out of the specified value, perform Idle Air Volume Learning, [EC-80](#), before conducting DTC Confirmation Procedure. For the target idle speed, refer to the Service Data and Specifications (SDS), [EC-721](#).

TESTING CONDITION:

- Before performing the following procedure, confirm that battery voltage is more than 11V at idle.
- Always perform the test at a temperature above -10°C (14°F).

④ WITH CONSULT-II

1. Open engine hood.
2. Start engine and warm it up to normal operating temperature.
3. Turn ignition switch OFF and wait at least 10 seconds.
4. Turn ignition switch ON again and select "DATA MONITOR" mode with CONSULT-II.
5. Start engine and run it for at least 1 minute at idle speed.
6. If 1st trip DTC is detected, go to [EC-513, "Diagnostic Procedure"](#).

DATA MONITOR	
MONITOR	NO DTC
ENG SPEED	XXX rpm
COOLANT TEMP/S	XXX °C

SEF174Y

④ WITH GST

Follow the procedure "WITH CONSULT-II" above.

DTC P0506 ISC SYSTEM

Diagnostic Procedure

UBS00PB2

1. CHECK INTAKE AIR LEAK

1. Start engine and let it idle.
2. Listen for an intake air leak after the mass air flow sensor.

OK or NG

- OK >> GO TO 2.
- NG >> Discover air leak location and repair.

2. REPLACE ECM

1. Stop engine.
2. Replace ECM.
3. Perform initialization of NVIS (NATS) system and registration of all NVIS (NATS) ignition key IDs. Refer to [BL-203, "NVIS\(NISSAN Vehicle Immobilizer System-NATS\)"](#) .
4. Perform [EC-79, "VIN Registration"](#) .
5. Perform [EC-80, "Accelerator Pedal Released Position Learning"](#) .
6. Perform [EC-80, "Throttle Valve Closed Position Learning"](#) .
7. Perform [EC-80, "Idle Air Volume Learning"](#) .

>> INSPECTION END

A

EC

C

D

E

F

G

H

I

J

K

L

M

DTC P0507 ISC SYSTEM

PFP:23781

Description

UBS00PB3

NOTE:

If DTC P0507 is displayed with other DTC, first perform the trouble diagnosis for the other DTC.

The ECM controls the engine idle speed to a specified level through the fine adjustment of the air, which is let into the intake manifold, by operating the electric throttle control actuator. The operating of the throttle valve is varied to allow for optimum control of the engine idling speed. The ECM calculates the actual engine speed from signals of crankshaft position sensor (POS) and camshaft position sensor (PHASE).

The ECM controls the electric throttle control actuator so that the engine speed coincides with the target value memorized in the ECM. The target engine speed is the lowest speed at which the engine can operate steadily. The optimum value stored in the ECM is determined by taking into consideration various engine conditions, such as during warming up, deceleration, and engine load (air conditioner, power steering and cooling fan operation, etc.).

On Board Diagnosis Logic

UBS00PB4

DTC No.	Trouble diagnosis name	DTC detecting condition	Possible cause
P0507 0507	Idle speed control system RPM higher than expected	The idle speed is more than the target idle speed by 200 rpm or more.	<ul style="list-style-type: none"> ● Electric throttle control actuator ● Intake air leak ● PCV system

DTC Confirmation Procedure

UBS00PB5

NOTE:

- If DTC Confirmation Procedure has been previously conducted, always turn ignition switch OFF and wait at least 10 seconds before conducting the next test.
- **If the target idle speed is out of the specified value, perform Idle Air Volume Learning, [EC-80](#) , before conducting DTC Confirmation Procedure. For the target idle speed, refer to the “Service Data and Specifications (SDS)”, [EC-721](#) .**

TESTING CONDITION:

- Before performing the following procedure, confirm that battery voltage is more than 11V at idle.
- Always perform the test at a temperature above -10°C (14°F).

Ⓜ WITH CONSULT-II

1. Open engine hood.
2. Start engine and warm it up to normal operating temperature.
3. Turn ignition switch OFF and wait at least 10 seconds.
4. Turn ignition switch ON again and select “DATA MONITOR” mode with CONSULT-II.
5. Start engine and run it for at least 1 minute at idle speed.
6. If 1st trip DTC is detected, go to [EC-515, "Diagnostic Procedure"](#)

DATA MONITOR	
MONITOR	NO DTC
ENG SPEED	XXX rpm
COOLAN TEMP/S	XXX °C

SEF174Y

Ⓜ WITH GST

Follow the procedure “WITH CONSULT-II” above.

DTC P0507 ISC SYSTEM

UBS00PB6

Diagnostic Procedure

1. CHECK PCV HOSE CONNECTION

Confirm that PCV hose is connected correctly.

OK or NG

OK >> GO TO 2.

NG >> Repair or replace.

2. CHECK INTAKE AIR LEAK

1. Start engine and let it idle.
2. Listen for an intake air leak after the mass air flow sensor.

OK or NG

OK >> GO TO 3.

NG >> Discover air leak location and repair.

3. REPLACE ECM

1. Stop engine.
2. Replace ECM.
3. Perform initialization of NVIS (NATS) system and registration of all NVIS (NATS) ignition key IDs. Refer to [BL-203, "NVIS\(NISSAN Vehicle Immobilizer System-NATS\)"](#).
4. Perform [EC-79, "VIN Registration"](#).
5. Perform [EC-80, "Accelerator Pedal Released Position Learning"](#).
6. Perform [EC-80, "Throttle Valve Closed Position Learning"](#).
7. Perform [EC-80, "Idle Air Volume Learning"](#).

>> **INSPECTION END**

DTC P0550 PSP SENSOR

PF:49763

DTC P0550 PSP SENSOR

Component Description

UBS00PB7

Power steering pressure (PSP) sensor is installed to the power steering high-pressure tube and detects a power steering load. This sensor is a potentiometer which transforms the power steering load into output voltage, and emits the voltage signal to the ECM. The ECM controls the electric throttle control actuator and adjusts the throttle valve opening angle to increase the engine speed and adjusts the idle speed for the increased load.

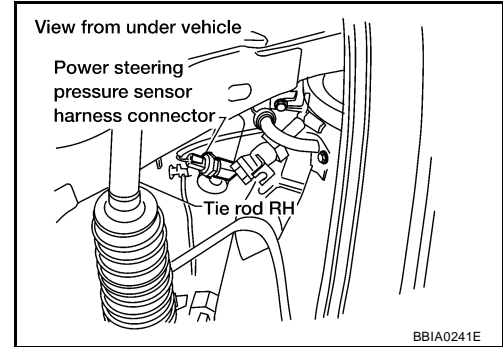

CONSULT-II Reference Value in Data Monitor Mode

UBS00PB8

Specification data are reference values.

MONITOR ITEM	CONDITION		SPECIFICATION
PW/ST SIGNAL	<ul style="list-style-type: none"> Engine: After warming up, idle the engine 	Steering wheel: Not being turned.	OFF
		Steering wheel: Being turned.	ON

On Board Diagnosis Logic

UBS00PB9

The MIL will not light up for this diagnosis.

NOTE:

If DTC P0550 is displayed with DTC P0643, first perform the trouble diagnosis for DTC P0643. Refer to [EC-529, "DTC P0643 SENSOR POWER SUPPLY"](#).

DTC No.	Trouble diagnosis name	DTC detecting condition	Possible cause
P0550 0550	Power steering pressure sensor circuit	An excessively low or high voltage from the sensor is sent to ECM.	<ul style="list-style-type: none"> Harness or connectors (The sensor circuit is open or shorted) Power steering pressure sensor

DTC Confirmation Procedure

UBS00PBA

NOTE:

If DTC Confirmation Procedure has been previously conducted, always turn ignition switch OFF and wait at least 10 seconds before conducting the next test.

WITH CONSULT-II

1. Turn ignition switch ON.
2. Select "DATA MONITOR" mode with CONSULT-II.
3. Start engine and let it idle for at least 5 seconds.
4. If 1st trip DTC is detected, go to [EC-519, "Diagnostic Procedure"](#)

DATA MONITOR	
MONITOR	NO DTC
ENG SPEED	XXX rpm

SEF058Y

WITH GST

Follow the procedure "WITH CONSULT-II" above.

DTC P0550 PSP SENSOR

Wiring Diagram

UBS00PBB

EC-PS/SEN-01

: DETECTABLE LINE FOR DTC
 : NON-DETECTABLE LINE FOR DTC

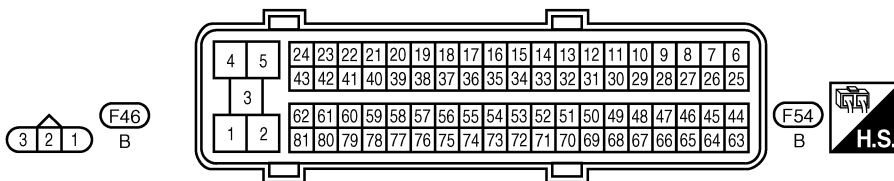
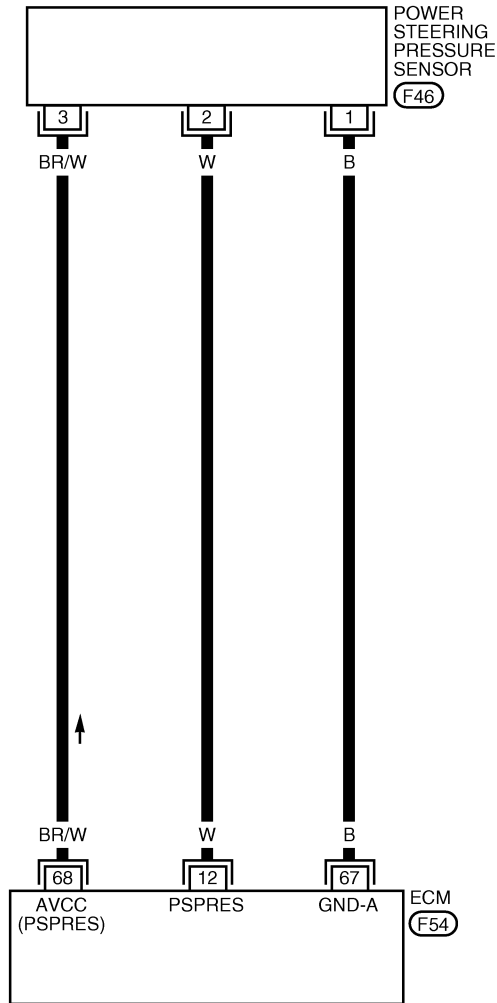

BBWA2523E

DTC P0550 PSP SENSOR

Specification data are reference values and are measured between each terminal and ground.

CAUTION:

Do not use ECM ground terminals when measuring input/output voltage. Doing so may result in damage to the ECM's transistor. Use a ground other than ECM terminals, such as the ground.

TER-MINAL NO.	WIRE COLOR	ITEM	CONDITION	DATA (DC Voltage)
12	W	Power steering pressure sensor	[Engine is running] ● Steering wheel: Being turned	0.5 - 4.5V
			[Engine is running] ● Steering wheel: Not being turned	0.4 - 0.8V
67	B	Sensor ground	[Engine is running] ● Warm-up condition ● Idle speed	Approximately 0V
68	BR/W	Power steering pressure sensor power supply	[Ignition switch ON]	Approximately 5V

DTC P0550 PSP SENSOR

UBS00PBC

Diagnostic Procedure

1. CHECK GROUND CONNECTIONS

1. Turn ignition switch OFF.
2. Loosen and retighten three ground screws on the body. Refer to [EC-158, "Ground Inspection"](#).

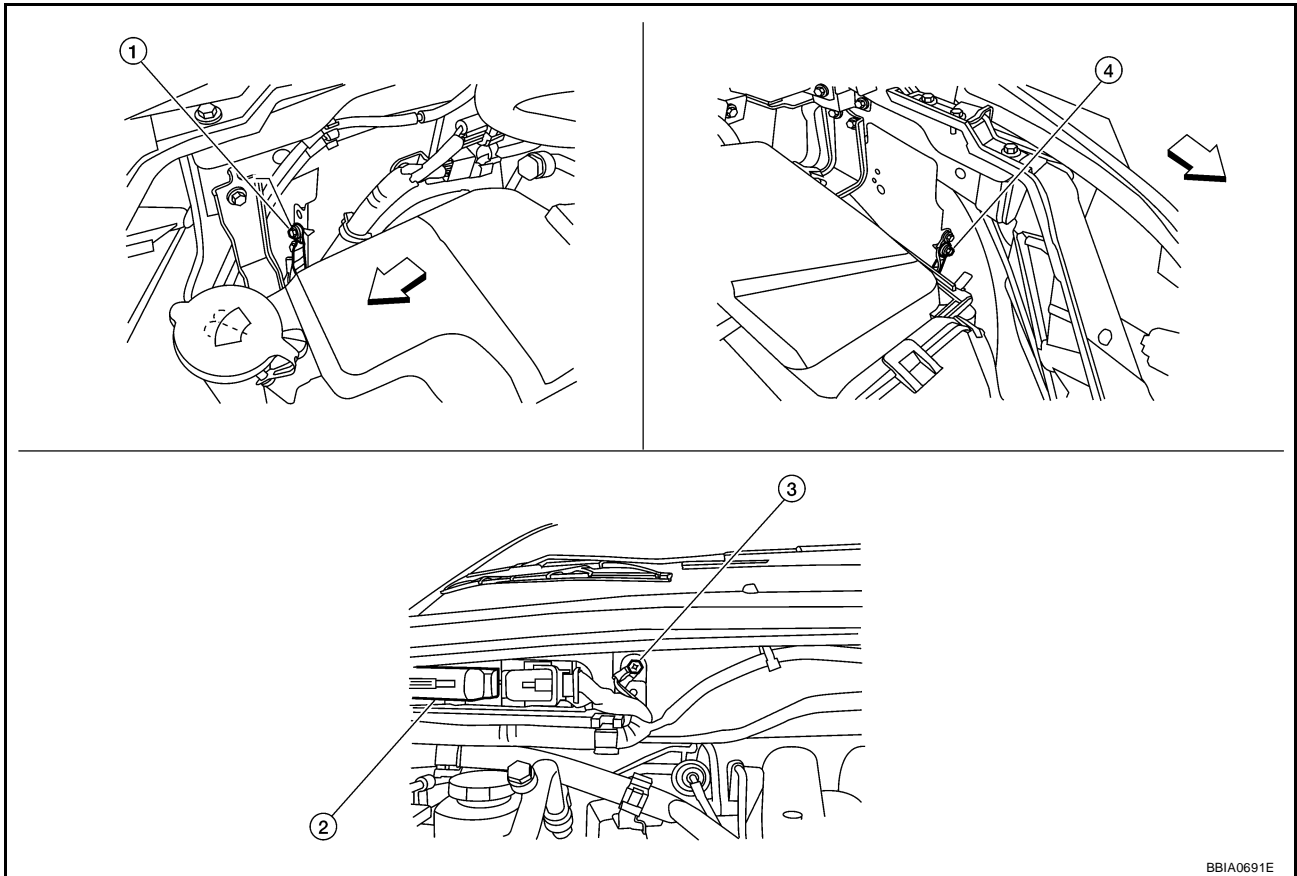

↔ Vehicle front

1. Body ground E24

2. ECM

3. Body ground E9

4. Body ground E15

OK or NG

OK >> GO TO 2.

NG >> Repair or replace ground connections.

DTC P0550 PSP SENSOR

2. CHECK PSP SENSOR POWER SUPPLY CIRCUIT

1. Disconnect power steering pressure (PSP) sensor harness connector.
2. Turn ignition switch ON.

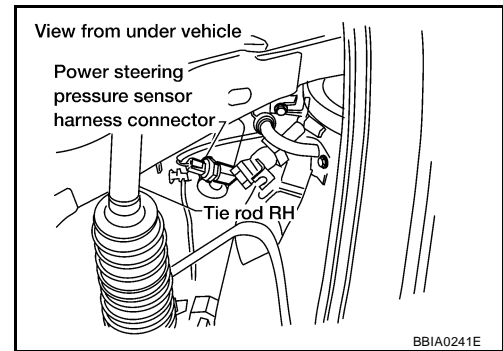

3. Check voltage between PSP sensor terminal 3 and ground with CONSULT-II or tester.

Voltage: Approximately 5V

OK or NG

- OK >> GO TO 3.
NG >> Repair open circuit or short to ground or short to power in harness or connectors.

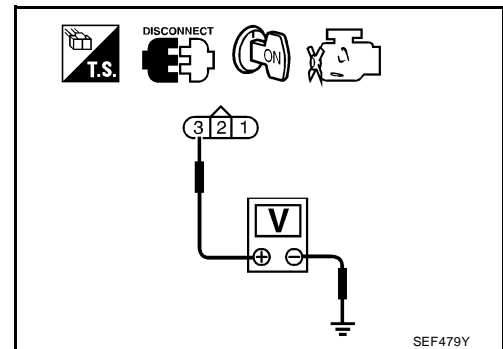

3. CHECK PSP SENSOR GROUND CIRCUIT FOR OPEN AND SHORT

1. Turn ignition switch OFF.
2. Disconnect ECM harness connector.
3. Check harness continuity between PSP sensor terminal 1 and ECM terminal 67. Refer to Wiring Diagram.

Continuity should exist.

4. Also check harness for short to ground and short to power.

OK or NG

- OK >> GO TO 4.
NG >> Repair open circuit or short to ground or short to power in harness or connectors.

4. CHECK PSP SENSOR INPUT SIGNAL CIRCUIT FOR OPEN AND SHORT

1. Check harness continuity between ECM terminal 12 and PSP sensor terminal 2. Refer to Wiring Diagram.

Continuity should exist.

2. Also check harness for short to ground and short to power.

OK or NG

- OK >> GO TO 5.
NG >> Repair open circuit or short to ground or short to power in harness or connectors.

5. CHECK PSP SENSOR

Refer to [EC-521, "Component Inspection"](#).

OK or NG

- OK >> GO TO 6.
NG >> Replace PSP sensor.

DTC P0550 PSP SENSOR

6. CHECK INTERMITTENT INCIDENT

Refer to [EC-149, "TROUBLE DIAGNOSIS FOR INTERMITTENT INCIDENT"](#) .

>> INSPECTION END

Component Inspection POWER STEERING PRESSURE SENSOR

UBS00PBD

1. Reconnect all harness connectors disconnected.
2. Start engine and let it idle.
3. Check voltage between ECM terminal 12 and ground under the following conditions.

Condition	Voltage
Steering wheel: Being turned	0.5 - 4.5V
Steering wheel: Not being turned	0.4 - 0.8V

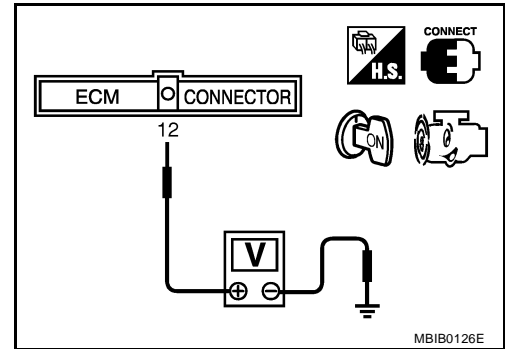

UBS00QAH

Removal and Installation POWER STEERING PRESSURE SENSOR

Refer to [PS-24, "HYDRAULIC LINE"](#) .

DTC P0603 ECM POWER SUPPLY

DTC P0603 ECM POWER SUPPLY

PF2:23710

Component Description

UBS00PBE

Battery voltage is supplied to the ECM even when the ignition switch is turned OFF for the ECM memory function of the DTC memory, the air-fuel ratio feedback compensation value memory, the idle air volume learning value memory, etc.

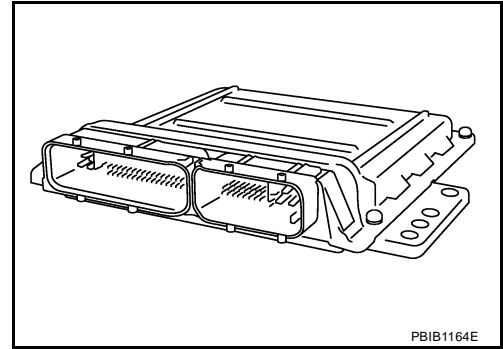

On Board Diagnosis Logic

UBS00PBF

DTC No.	Trouble diagnosis name	DTC detecting condition	Possible cause
P0603 0603	ECM power supply circuit	ECM back-up RAM system does not function properly.	<ul style="list-style-type: none"> ● Harness or connectors [ECM power supply (back-up) circuit is open or shorted.] ● ECM

DTC Confirmation Procedure

UBS00PBG

NOTE:

If DTC Confirmation Procedure has been previously conducted, always turn ignition switch OFF and wait at least 10 seconds before conducting the next test.

WITH CONSULT-II

1. Turn ignition switch ON and select "DATA MONITOR" mode with CONSULT-II.
2. Start engine and let it idle for 1 second.
3. Turn ignition switch OFF and wait at least 10 seconds.
4. Turn ignition switch ON and wait at least 1 second.
5. Repeat step 2 to 4 for 4 times.
6. If 1st trip DTC is detected, go to [EC-524, "Diagnostic Procedure"](#)

DATA MONITOR	
MONITOR	NO DTC
ENG SPEED	XXX rpm

SEF058Y

WITH GST

Follow the procedure "WITH CONSULT-II" above.

DTC P0603 ECM POWER SUPPLY

Wiring Diagram

UBS00PBH

EC-ECM/PW-01

: DETECTABLE LINE FOR DTC
 : NON-DETECTABLE LINE FOR DTC

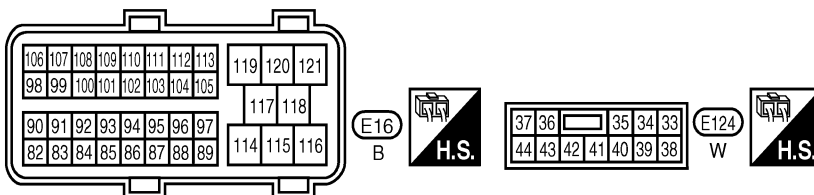
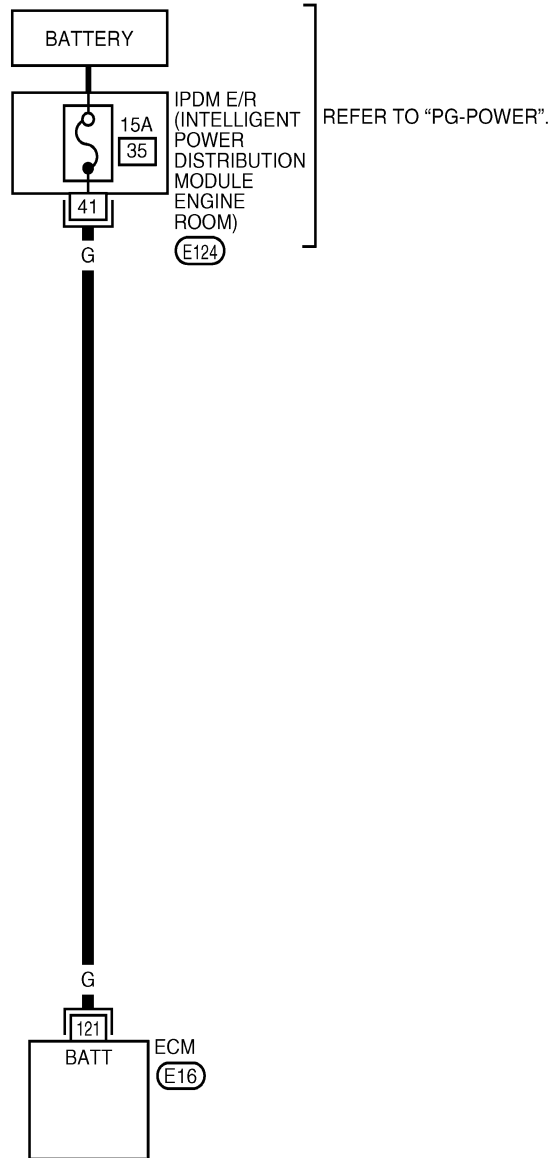

BBWA2524E

DTC P0603 ECM POWER SUPPLY

Specification data are reference values and are measured between each terminal and ground.

CAUTION:

Do not use ECM ground terminals when measuring input/output voltage. Doing so may result in damage to the ECM's transistor. Use a ground other than ECM terminals, such as the ground.

TER-MINAL NO.	WIRE COLOR	ITEM	CONDITION	DATA (DC Voltage)
121	G	Power supply for ECM (Back-up)	[Ignition switch: OFF]	BATTERY VOLTAGE (11 - 14V)

Diagnostic Procedure

UBS00PBI

1. CHECK ECM POWER SUPPLY

1. Turn ignition switch OFF.
2. Disconnect ECM harness connector.
3. Check voltage between ECM terminal 121 and ground with CONSULT-II or tester.

Voltage: Battery voltage

OK or NG

- OK >> GO TO 3.
- NG >> GO TO 2.

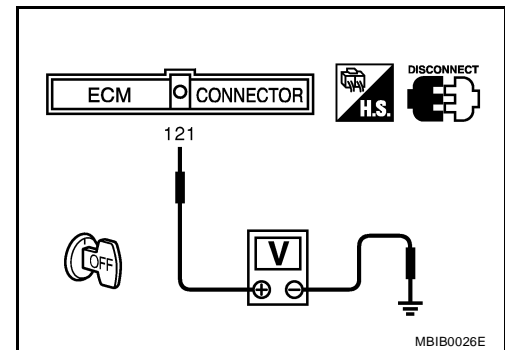

2. DETECT MALFUNCTIONING PART

Check the following.

- IPDM E/R harness connector E124
- 15A fuse
- Harness for open or short between ECM and battery

>> Repair or replace harness or connectors.

3. CHECK INTERMITTENT INCIDENT

Refer to [EC-149, "TROUBLE DIAGNOSIS FOR INTERMITTENT INCIDENT"](#) .

OK or NG

- OK >> GO TO 4.
- NG >> Repair or replace harness or connectors.

DTC P0603 ECM POWER SUPPLY

4. PERFORM DTC CONFIRMATION PROCEDURE

With CONSULT-II

1. Turn ignition switch ON.
2. Select "SELF DIAG RESULTS" mode with CONSULT-II.
3. Touch "ERASE".
4. **Perform DTC Confirmation Procedure.**
See [EC-522, "DTC Confirmation Procedure"](#) .
5. Is the 1st trip DTC P0603 displayed again?

With GST

1. Turn ignition switch ON.
2. Select Service \$04 with GST.
3. **Perform DTC Confirmation Procedure.**
See [EC-522, "DTC Confirmation Procedure"](#) .
4. Is the 1st trip DTC P0603 displayed again?

Yes or No

Yes >> GO TO 5.

No >> **INSPECTION END**

5. REPLACE ECM

1. Replace ECM.
2. Perform initialization of NVIS (NATS) system and registration of all NVIS (NATS) ignition key IDs. Refer to [BL-203, "NVIS\(NISSAN Vehicle Immobilizer System-NATS\)"](#) .
3. Perform [EC-79, "VIN Registration"](#) .
4. Perform [EC-80, "Accelerator Pedal Released Position Learning"](#) .
5. Perform [EC-80, "Throttle Valve Closed Position Learning"](#) .
6. Perform [EC-80, "Idle Air Volume Learning"](#) .

>> **INSPECTION END**

A

EC

C

D

E

F

G

H

I

J

K

L

M

DTC P0605 ECM

PF2:23710

DTC P0605 ECM

Component Description

UBS00PBJ

The ECM consists of a microcomputer and connectors for signal input and output and for power supply. The ECM controls the engine.

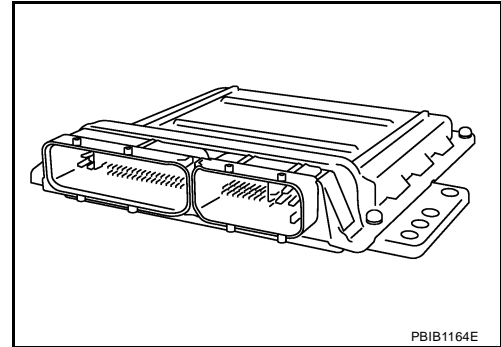

UBS00PBK

On Board Diagnosis Logic

This self-diagnosis has one or two trip detection logic.

DTC No.	Trouble diagnosis name	DTC detecting condition		Possible cause
P0605 0605	Engine control module	A)	ECM calculation function is malfunctioning.	● ECM
		B)	ECM EEP-ROM system is malfunctioning.	
		C)	ECM self shut-off function is malfunctioning.	

FAIL-SAFE MODE

ECM enters fail-safe mode when the malfunction A is detected.

Detected items	Engine operation condition in fail-safe mode
Malfunction A	<ul style="list-style-type: none"> ● ECM stops the electric throttle control actuator control, throttle valve is maintained at a fixed opening (approx. 5 degrees) by the return spring. ● ECM deactivates ASCD operation.

DTC Confirmation Procedure

UBS00PBL

Perform **PROCEDURE FOR MALFUNCTION A** first. If the 1st trip DTC cannot be confirmed, perform **PROCEDURE FOR MALFUNCTION B**. If there is no malfunction on **PROCEDURE FOR MALFUNCTION B**, perform **PROCEDURE FOR MALFUNCTION C**.

NOTE:

If DTC Confirmation Procedure has been previously conducted, always turn ignition switch OFF and wait at least 10 seconds before conducting the next test.

PROCEDURE FOR MALFUNCTION A

Ⓜ With CONSULT-II

1. Turn ignition switch ON.
2. Select "DATA MONITOR" mode with CONSULT-II.
3. If 1st trip DTC is detected, go to [EC-527, "Diagnostic Procedure"](#)

DATA MONITOR	
MONITOR	NO DTC
ENG SPEED	XXX rpm

SEP058Y

Ⓜ With GST

Follow the procedure "With CONSULT-II" above.

DTC P0605 ECM

PROCEDURE FOR MALFUNCTION B

With CONSULT-II

1. Turn ignition switch ON and wait at least 1 second.
2. Select "DATA MONITOR" mode with CONSULT-II.
3. Turn ignition switch OFF, wait at least 10 seconds and then turn ON.
4. If 1st trip DTC is detected, go to [EC-527, "Diagnostic Procedure"](#)

DATA MONITOR	
MONITOR	NO DTC
ENG SPEED	XXX rpm

SEF058Y

With GST

Follow the procedure "With CONSULT-II" above.

PROCEDURE FOR MALFUNCTION C

With CONSULT-II

1. Turn ignition switch ON and wait at least 1 second.
2. Select "DATA MONITOR" mode with CONSULT-II.
3. Turn ignition switch OFF, wait at least 10 seconds and then turn ON.
4. Repeat step 3 for 32 times
5. If 1st trip DTC is detected, go to [EC-527, "Diagnostic Procedure"](#)

DATA MONITOR	
MONITOR	NO DTC
ENG SPEED	XXX rpm

SEF058Y

With GST

Follow the procedure "With CONSULT-II" above.

Diagnostic Procedure

1. INSPECTION START

With CONSULT-II

1. Turn ignition switch ON.
2. Select "SELF DIAG RESULTS" mode with CONSULT-II.
3. Touch "ERASE".
4. **Perform DTC Confirmation Procedure.**
See [EC-526, "DTC Confirmation Procedure"](#) .
5. Is the 1st trip DTC P0605 displayed again?

With GST

1. Turn ignition switch ON.
2. Select Service \$04 with GST.
3. **Perform DTC Confirmation Procedure.**
See [EC-526, "DTC Confirmation Procedure"](#) .
4. Is the 1st trip DTC P0605 displayed again?

Yes or No

Yes >> GO TO 2.

No >> **INSPECTION END**

DTC P0605 ECM

2. REPLACE ECM

1. Replace ECM.
2. Perform initialization of NVIS (NATS) system and registration of all NVIS (NATS) ignition key IDs. Refer to [BL-203, "NVIS\(NISSAN Vehicle Immobilizer System-NATS\)"](#) .
3. Perform [EC-79, "VIN Registration"](#) .
4. Perform [EC-80, "Accelerator Pedal Released Position Learning"](#) .
5. Perform [EC-80, "Throttle Valve Closed Position Learning"](#) .
6. Perform [EC-80, "Idle Air Volume Learning"](#) .

>> INSPECTION END

DTC P0643 SENSOR POWER SUPPLY

DTC P0643 SENSOR POWER SUPPLY

PFP:18919

On Board Diagnosis Logic

UBS00PBN

This self-diagnosis has the one trip detection logic.

DTC No.	Trouble diagnosis name	DTC detecting condition	Possible cause
P0643 0643	Sensor power supply circuit short	ECM detects a voltage of power source for sensor is excessively low or high.	<ul style="list-style-type: none"> ● Harness or connectors (APP sensor 1 circuit is shorted.) (PSP sensor circuit is shorted.) (EVAP control system pressure sensor is shorted.) (Refrigerant pressure sensor circuit is shorted.) ● Accelerator pedal position sensor (APP sensor 1) ● Power steering pressure sensor ● EVAP control system pressure sensor ● Refrigerant pressure sensor

FAIL-SAFE MODE

When the malfunction is detected, ECM enters fail-safe mode and the MIL lights up.

Engine operation condition in fail-safe mode

ECM stops the electric throttle control actuator control, throttle valve is maintained at a fixed opening (approx. 5 degrees) by the return spring.

DTC Confirmation Procedure

UBS00PBO

NOTE:

If DTC Confirmation Procedure has been previously conducted, always turn ignition switch OFF and wait at least 10 seconds before conducting the next test.

TESTING CONDITION:

Before performing the following procedure, confirm that battery voltage is more than 10V at idle.

WITH CONSULT-II

1. Turn ignition switch ON.
2. Select "DATA MONITOR" mode with CONSULT-II.
3. Start engine and let it idle for 1 second.
4. If DTC is detected, go to [EC-532, "Diagnostic Procedure"](#) .

DATA MONITOR	
MONITOR	NO DTC
ENG SPEED	XXX rpm

SEF058Y

WITH GST

Follow the procedure "WITH CONSULT-II" above.

DTC P0643 SENSOR POWER SUPPLY

UBS00BPB

Wiring Diagram

EC-SEN/PW-01

: DETECTABLE LINE FOR DTC
 : NON-DETECTABLE LINE FOR DTC

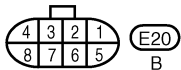
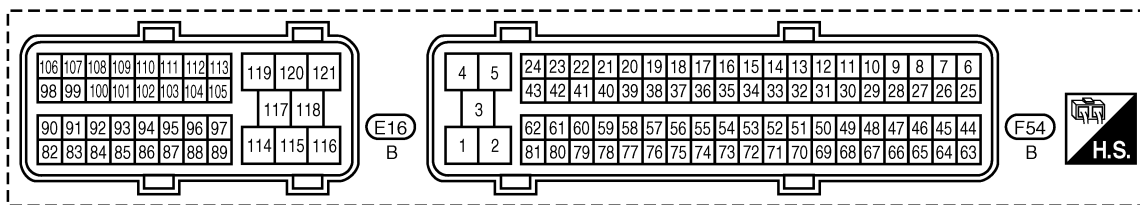
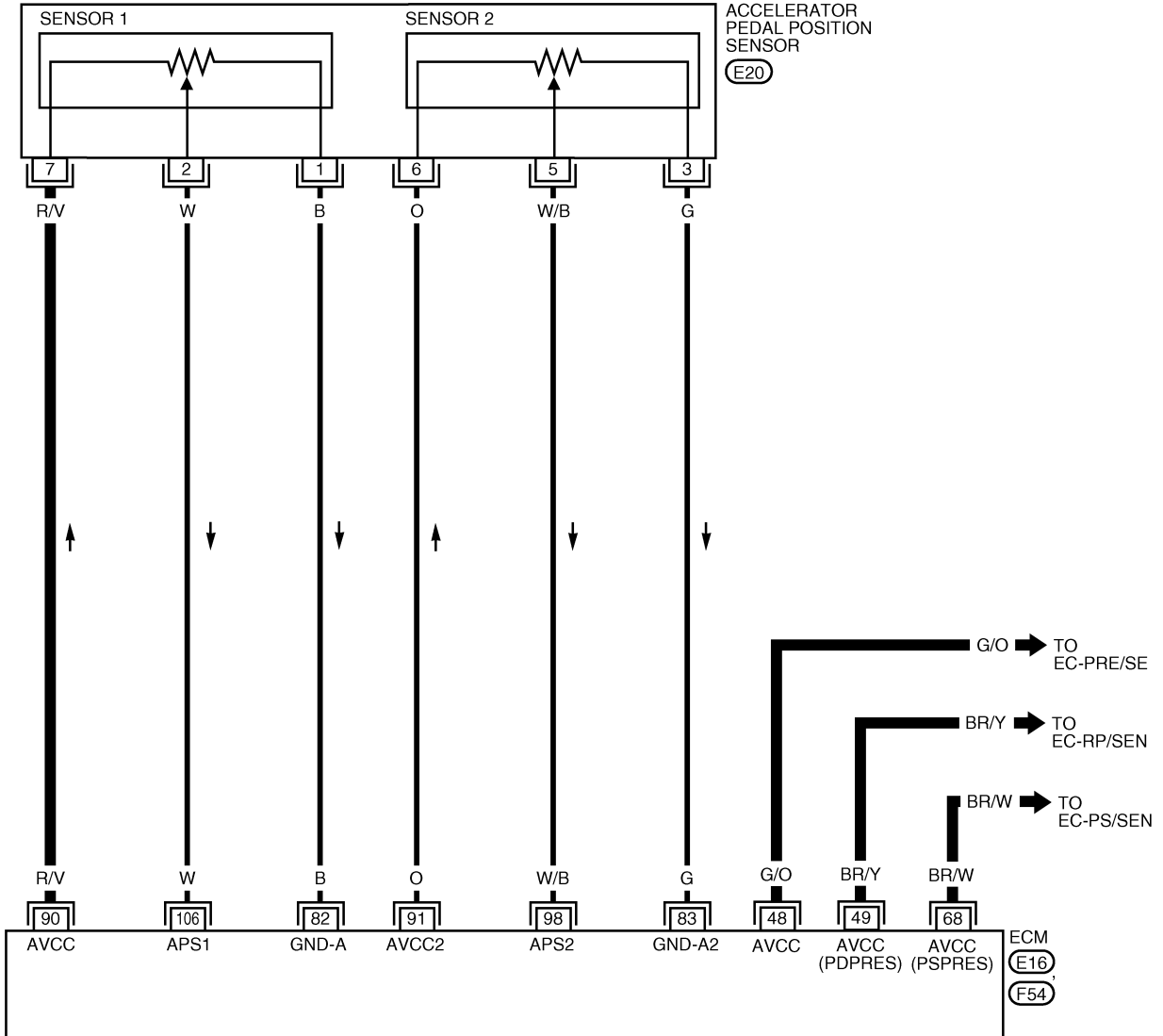

BBWA2008E

DTC P0643 SENSOR POWER SUPPLY

Specification data are reference values and are measured between each terminal and ground.

CAUTION:

Do not use ECM ground terminals when measuring input/output voltage. Doing so may result in damage to the ECM's transistor. Use a ground other than ECM terminals, such as the ground.

TER-MINAL NO.	WIRE COLOR	ITEM	CONDITION	DATA (DC Voltage)
48	G/O	EVAP control system pressure sensor power supply	[Ignition switch: ON]	Approximately 5V
49	BR/Y	Refrigerant pressure sensor power supply	[Ignition switch: ON]	Approximately 5V
68	BR/W	PSP sensor power supply	[Ignition switch: ON]	Approximately 5V
82	B	APP sensor 1 ground	[Engine is running] ● Warm-up condition ● Idle speed	Approximately 0V
83	G	APP sensor 2 ground	[Engine is running] ● Warm-up condition ● Idle speed	Approximately 0V
90	R/V	APP sensor 1 power supply	[Ignition switch: ON]	Approximately 5V
91	O	APP sensor 2 power supply	[Ignition switch: ON]	Approximately 5V
98	W/B	Accelerator pedal position sensor 2	[Ignition switch: ON] ● Engine stopped ● Accelerator pedal: Fully released	0.25 - 0.5V
			[Ignition switch: ON] ● Engine stopped ● Accelerator pedal: Fully depressed	2.0 - 2.5V
106	W	Accelerator pedal position sensor 1	[Ignition switch: ON] ● Engine stopped ● Accelerator pedal: Fully released	0.5 - 1.0V
			[Ignition switch: ON] ● Engine stopped ● Accelerator pedal: Fully depressed	4.2 - 4.8V

A

EC

C

D

E

F

G

H

I

J

K

L

M

DTC P0643 SENSOR POWER SUPPLY

UBS00PBG

Diagnostic Procedure

1. CHECK GROUND CONNECTIONS

1. Turn ignition switch OFF.
2. Loosen and retighten three ground screws on the body. Refer to [EC-158, "Ground Inspection"](#).

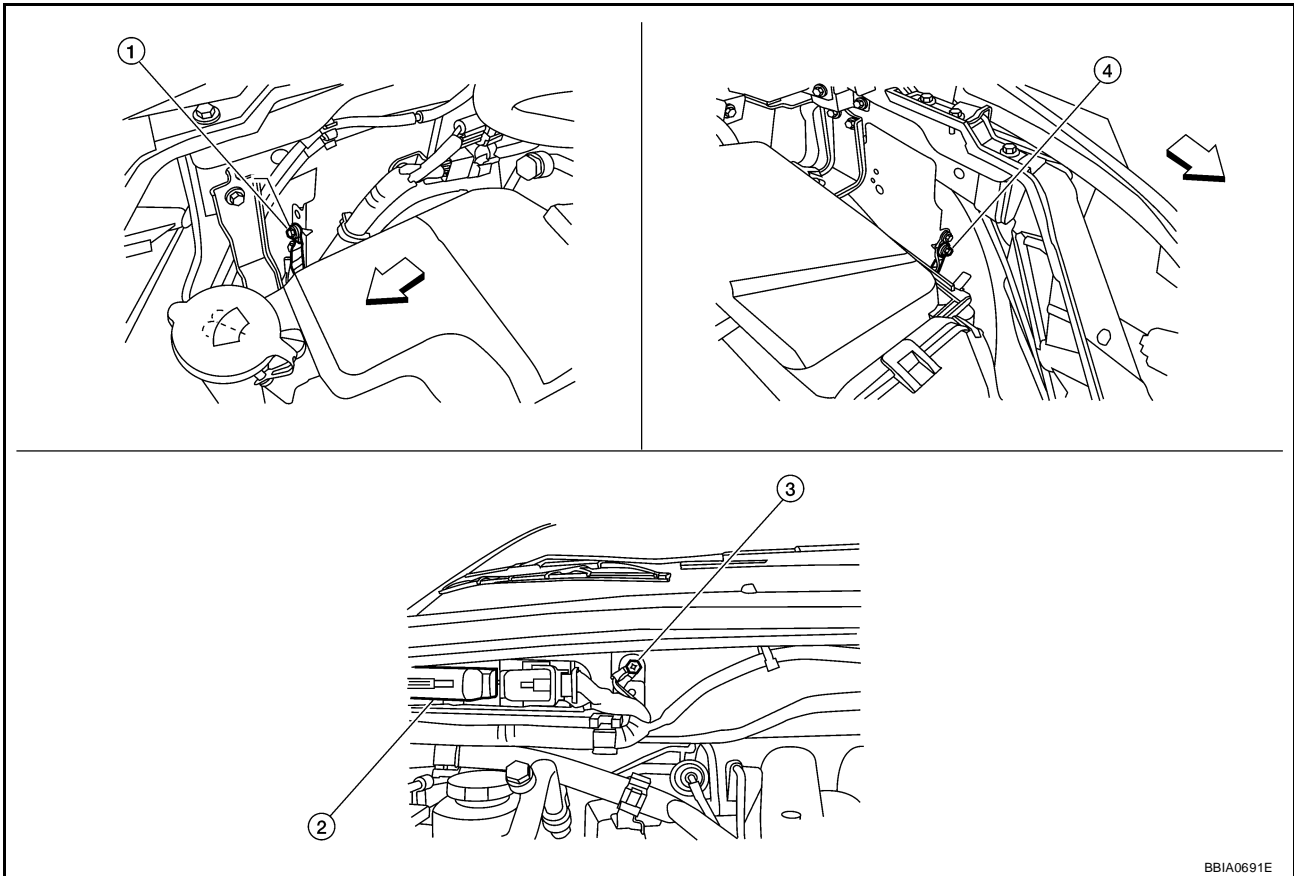

BBIA0691E

← Vehicle front

1. Body ground E24

2. ECM

3. Body ground E9

4. Body ground E15

OK or NG

OK >> GO TO 2.

NG >> Repair or replace ground connections.

DTC P0643 SENSOR POWER SUPPLY

2. CHECK ACCELERATOR PEDAL POSITION SENSOR 1 POWER SUPPLY CIRCUIT-I

1. Disconnect accelerator pedal position (APP) sensor harness connector.
2. Turn ignition switch ON.

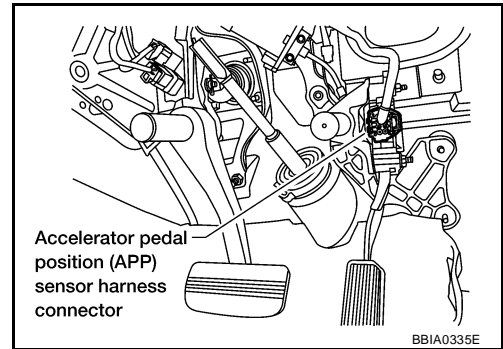

3. Check voltage between APP sensor terminal 7 and ground with CONSULT-II or tester.

Voltage: Approximately 5V

OK or NG

- OK >> GO TO 6.
 NG >> GO TO 3.

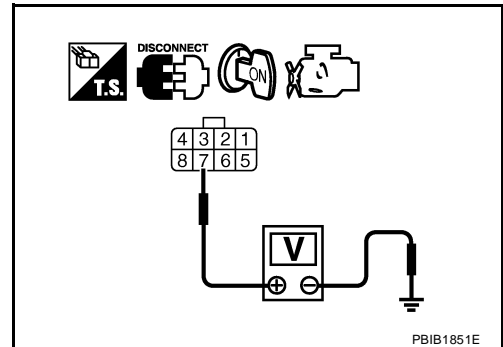

3. CHECK ACCELERATOR PEDAL POSITION SENSOR 1 POWER SUPPLY CIRCUIT-II

1. Turn ignition switch OFF.
2. Disconnect ECM harness connector.
3. Check harness continuity between APP sensor terminal 7 and ECM terminal 90. Refer to Wiring Diagram.

Continuity should exist.

OK or NG

- OK >> GO TO 4.
 NG >> Repair open circuit.

4. CHECK SENSOR POWER SUPPLY CIRCUITS

Check harness for short to power and short to ground, between the following terminals.

ECM terminal	Sensor terminal	Reference Wiring Diagram
90	APP sensor terminal 7	EC-530
48	EVAP control system pressure sensor terminal 3	EC-474
49	Refrigerant pressure sensor terminal 1	EC-705
68	PSP sensor terminal 3	EC-517

OK or NG

- OK >> GO TO 5.
 NG >> Repair short to ground or short to power in harness or connectors.

DTC P0643 SENSOR POWER SUPPLY

5. CHECK COMPONENTS

Check the following.

- EVAP control system pressure sensor (Refer to [EC-478, "Component Inspection"](#) .)
- Refrigerant pressure sensor (Refer to [MTC-32, "TROUBLE DIAGNOSIS"](#)).
- Power steering pressure sensor (Refer to [EC-521, "Component Inspection"](#) .)

OK or NG

- OK >> GO TO 8.
- NG >> Replace malfunctioning component.

6. CHECK APP SENSOR

Refer to [EC-623, "Component Inspection"](#) .

OK or NG

- OK >> GO TO 8.
- NG >> GO TO 7.

7. REPLACE ACCELERATOR PEDAL ASSEMBLY

1. Replace accelerator pedal assembly.
2. Perform [EC-80, "Accelerator Pedal Released Position Learning"](#) .
3. Perform [EC-80, "Throttle Valve Closed Position Learning"](#) .
4. Perform [EC-80, "Idle Air Volume Learning"](#) .

>> INSPECTION END

8. CHECK INTERMITTENT INCIDENT

Refer to [EC-149, "TROUBLE DIAGNOSIS FOR INTERMITTENT INCIDENT"](#) .

>> INSPECTION END

DTC P0850 PNP SWITCH

PFP:23006

DTC P0850 PNP SWITCH

Component Description

UBS00PBR

When the shift position is P or N, park/neutral position (PNP) switch is turned ON. ECM detects the position because the continuity of the line (the ON signal) exists. The park/neutral position (PNP) switch assembly also indicates a transmission range switch to detect shift lever position.

CONSULT-II Reference Value in Data Monitor Mode

UBS00PBS

Specification data are reference values.

MONITOR ITEM	CONDITION		SPECIFICATION
P/N POSI SW	● Ignition switch: ON	Shift lever: P or N	ON
		Shift lever: Except above	OFF

On Board Diagnosis Logic

UBS00PBT

DTC No.	Trouble diagnosis name	DTC detecting condition	Possible cause
P0850 0850	Park/neutral position switch	The signal of the park/neutral position (PNP) switch is not changed in the process of engine starting and driving.	<ul style="list-style-type: none"> ● Harness or connectors [The park/neutral position (PNP) switch circuit is open or shorted.] ● Park/neutral position (PNP) switch

DTC Confirmation Procedure

UBS00PBU

CAUTION:

Always drive vehicle at a safe speed.

NOTE:

If DTC Confirmation Procedure has been previously conducted, always turn ignition switch OFF and wait at least 10 seconds before conducting the next test.

WITH CONSULT-II

1. Turn ignition switch ON.
2. Select "P/N POSI SW" in "DATA MONITOR" mode with CONSULT-II. Then check the "P/N POSI SW" signal under the following conditions.

Position (Selector lever)	Known-good signal
P or N position	ON
Except above position	OFF

If NG, go to [EC-538, "Diagnostic Procedure"](#) .

If OK, go to following step.

3. Select "DATA MONITOR" mode with CONSULT-II.
4. Start engine and warm it up to normal operating temperature.
5. Maintain the following conditions for at least 60 consecutive seconds.

ENG SPEED	1,200 - 6,375 rpm
COOLAN TEMP/S	More than 70°C (158°F)
B/FUEL SCHDL	2.0 - 31.8 msec
VHCL SPEED SE	More than 64 km/h (40 MPH)
Shift lever	Suitable position

6. If 1st trip DTC is detected, go to [EC-538, "Diagnostic Procedure"](#)

DATA MONITOR	
MONITOR	NO DTC
P/N POSI SW	ON

SEF212Y

DATA MONITOR	
MONITOR	NO DTC
ENG SPEED	XXX rpm
COOLAN TEMP/S	XXX °C
VHCL SPEED SE	XXX km/h
P/N POSI SW	OFF
B/FUEL SCHDL	XXX msec

SEF213Y

DTC P0850 PNP SWITCH

UBS00PBV

Overall Function Check

Use this procedure to check the overall function of the park/neutral position (PNP) switch circuit. During this check, a 1st trip DTC might not be confirmed.

WITH GST

1. Turn ignition switch ON.
2. Check voltage between ECM terminal 102 (PNP switch signal) and ground under the following conditions.

Condition (Gear position)	Voltage V (Known-good data)
P or N position	Approx. 0
Except above position	BATTERY VOLTAGE (11 - 14V)

3. If NG, go to [EC-538, "Diagnostic Procedure"](#).

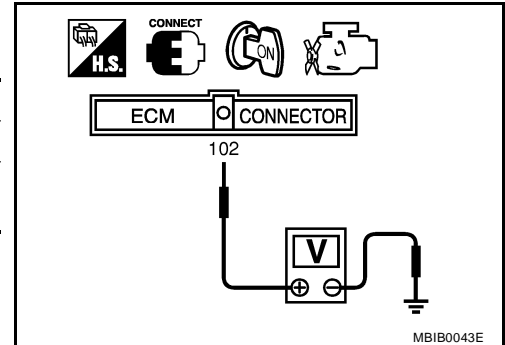

DTC P0850 PNP SWITCH

Wiring Diagram

UBS00PBW

EC-PNP/SW-01

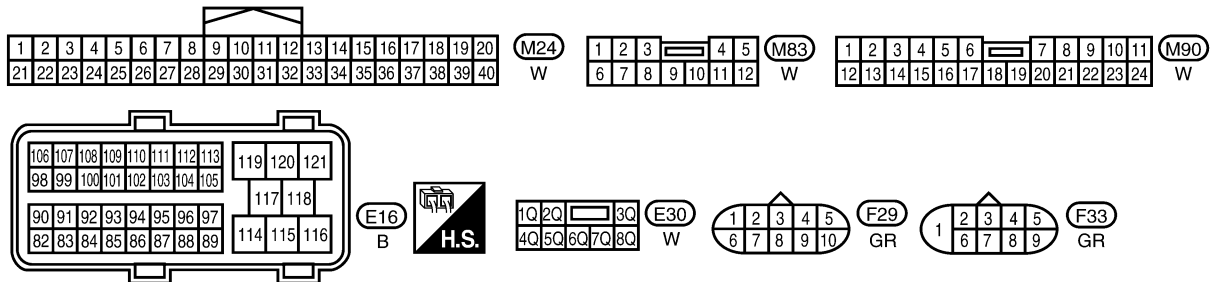
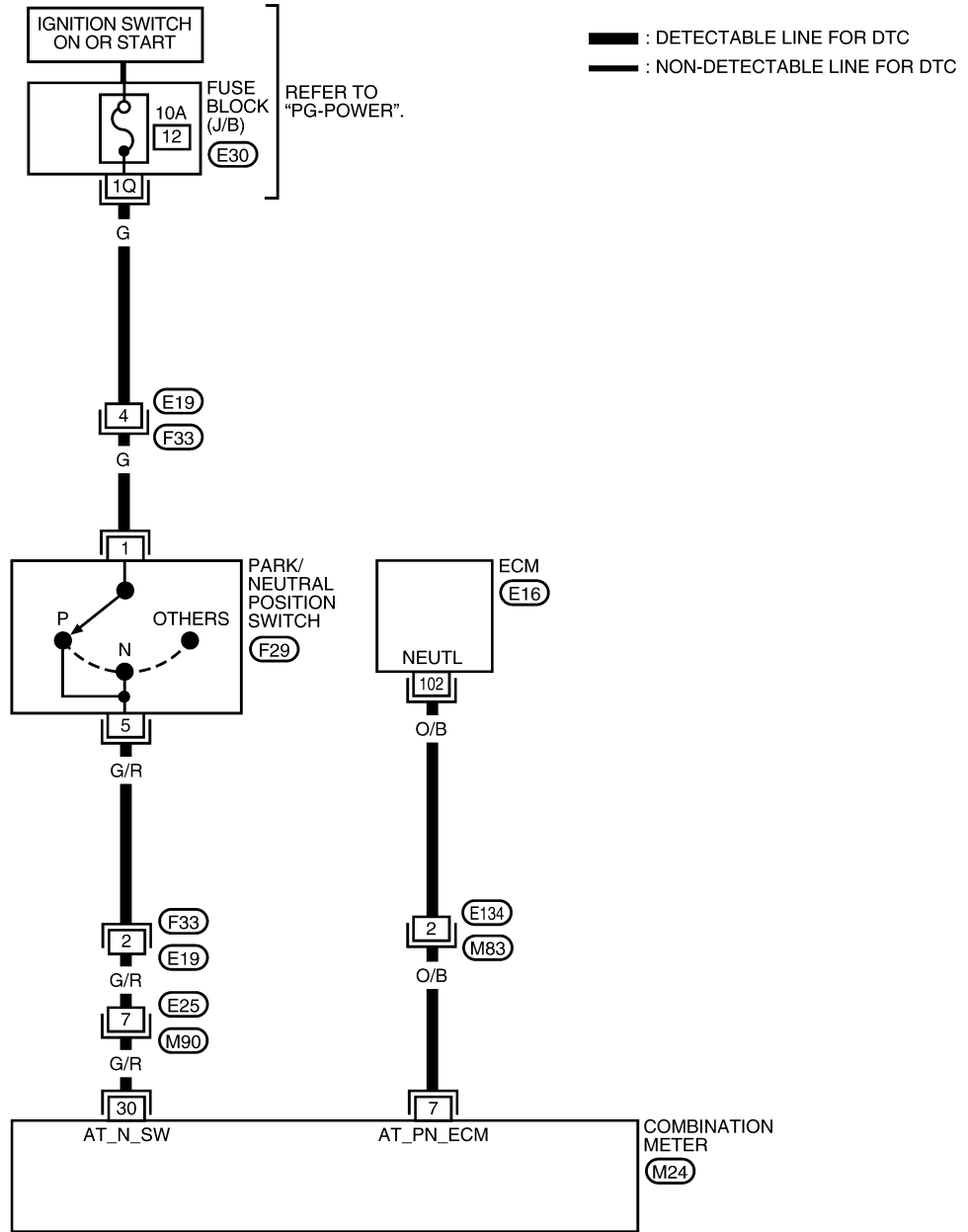

BBWA2532E

DTC P0850 PNP SWITCH

Specification data are reference values and are measured between each terminal and ground.

CAUTION:

Do not use ECM ground terminals when measuring input/output voltage. Doing so may result in damage to the ECM's transistor. Use a ground other than ECM terminals, such as the ground.

TER-MINAL NO.	WIRE COLOR	ITEM	CONDITION	DATA (DC Voltage)
102	O/B	PNP switch	[Ignition switch: ON] ● Shift lever: P or N	BATTERY VOLTAGE (11 - 14V)
			[Ignition switch: ON] ● Except above position	Approximately 0V

Diagnostic Procedure

UBS00PBX

1. CHECK STARTING SYSTEM

Turn ignition switch OFF, then turn it to START.

Does starter motor operate?

Yes or No

Yes >> GO TO 2.

No >> Refer to [SC-10, "STARTING SYSTEM"](#) .

2. CHECK PNP SWITCH INPUT SIGNAL CIRCUIT FOR OPEN AND SHORT-I

- Turn ignition switch OFF, wait at least 10 seconds and then turn ON.
- Check voltage between combination meter terminal 30 and ground with CONSULT-II or tester under the following conditions.

Condition (Shift position)	Voltage
P or N position	BATTERY VOLTAGE (11 - 14V)
Except above position	Approximately 0 V

OK or NG

OK >> GO TO 9.

NG >> GO TO 3.

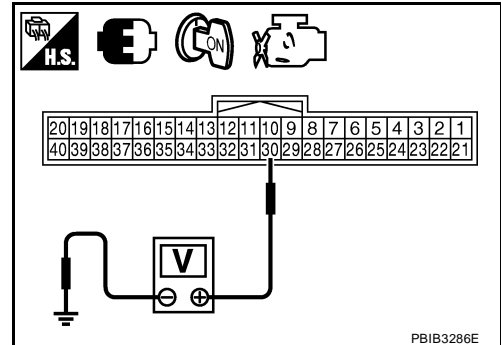

DTC P0850 PNP SWITCH

3. CHECK PNP SWITCH POWER SUPPLY CIRCUIT

1. Turn ignition switch OFF.
2. Disconnect PNP switch harness connector (1).
 - ⇐: Vehicle front
3. Turn ignition switch ON.

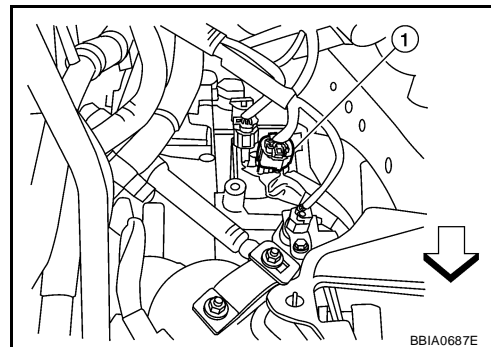

4. Check voltage between PNP switch terminal 1 and ground with CONSULT-II or tester.
Refer to Wiring Diagram.

Voltage: Battery voltage

OK or NG

- OK >> GO TO 5.
- NG >> GO TO 4.

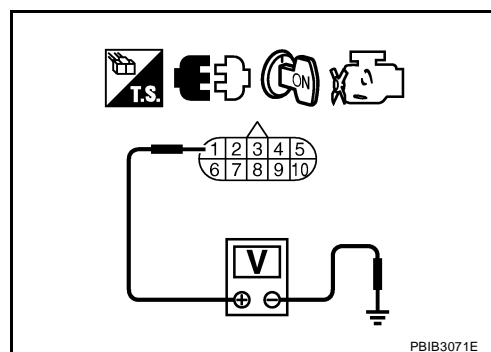

4. DETECT MALFUNCTIONING PART

Check the following.

- Harness connectors E19, F33
- Fuse block (J/B) connector E30
- 10A fuse
- Harness for open or short between PNP switch and fuse

>> Repair open circuit or short to ground or short to power in harness or connectors.

5. CHECK PNP SWITCH INPUT SIGNAL CIRCUIT FOR OPEN AND SHORT-I

1. Check harness continuity between PNP switch terminal 5 and combination meter terminal 30.
Refer to Wiring Diagram.

Continuity should exist.

2. Also check harness for short to ground and short to power.

OK or NG

- OK >> GO TO 7.
- NG >> GO TO 6.

DTC P0850 PNP SWITCH

6. DETECT MALFUNCTIONING PART

Check the following.

- Harness connectors F33, E19
- Harness connectors E25, M90
- Harness for open or short between PNP switch and combination meter

>> Repair open circuit or short to ground or short to power in harness or connectors.

7. CHECK PNP SWITCH

Refer to [AT-91, "DTC P0705 PARK/NEUTRAL POSITION SWITCH"](#) .

OK or NG

OK >> GO TO 8.

NG >> Replace PNP switch.

8. CHECK INTERMITTENT INCIDENT

Refer to [EC-149, "TROUBLE DIAGNOSIS FOR INTERMITTENT INCIDENT"](#) .

>> **INSPECTION END**

9. CHECK PNP SWITCH INPUT SIGNAL CIRCUIT FOR OPEN AND SHORT-II

1. Turn ignition switch OFF.
2. Disconnect ECM harness connector.
3. Check harness continuity between ECM terminal 102 and combination meter terminal 7.
Refer to Wiring Diagram.

Continuity should exist.

4. Also check harness for short to ground and short to power.

OK or NG

OK >> GO TO 11.

NG >> GO TO 10.

10. DETECT MALFUNCTIONING PART

Check the following.

- Harness connectors E134, M83
- Harness for open or short between ECM and combination meter

>> Repair open circuit or short to ground or short to power in harness or connectors.

11. CHECK COMBINATION METER

Refer to [DI-5, "COMBINATION METERS"](#) .

OK or NG

OK >> GO TO 12.

NG >> Replace combination meter

12. CHECK INTERMITTENT INCIDENT

Refer to [EC-149, "TROUBLE DIAGNOSIS FOR INTERMITTENT INCIDENT"](#) .

>> **INSPECTION END**

DTC P1148, P1168 CLOSED LOOP CONTROL

DTC P1148, P1168 CLOSED LOOP CONTROL

PDF:22690

On Board Diagnosis Logic

UBS00PBY

These self-diagnoses have the one trip detection logic.

DTC No.	Trouble diagnosis name	DTC detecting condition	Possible cause
P1148 1148 (Bank 1)	Closed loop control function	The closed loop control function for bank 1 does not operate even when vehicle is driving in the specified condition.	<ul style="list-style-type: none"> ● Harness or connectors [The air fuel ratio (A/F) sensor 1 circuit is open or shorted.]
P1168 1168 (Bank 2)		The closed loop control function for bank 2 does not operate even when vehicle is driving in the specified condition.	<ul style="list-style-type: none"> ● Air fuel ratio (A/F) sensor 1 ● Air fuel ratio (A/F) sensor 1 heater

NOTE:

DTC P1148 or P1168 is displayed with another DTC for air fuel ratio (A/F) sensor 1.
Perform the trouble diagnosis for the corresponding DTC.

A
EC
C
D
E
F
G
H
I
J
K
L
M

DTC P1211 TCS CONTROL UNIT

DTC P1211 TCS CONTROL UNIT

PF:47850

Description

UBS00PBZ

The malfunction information related to TCS is transferred through the CAN communication line from “ABS actuator and electric unit (control unit)” to ECM.

Be sure to erase the malfunction information such as DTC not only for “ABS actuator and electric unit (control unit)” but also for ECM after TCS related repair.

On Board Diagnosis Logic

UBS00PC0

**Freeze frame data is not stored in the ECM for this self-diagnosis.
The MIL will not light up for this self-diagnosis.**

DTC No.	Trouble diagnosis name	DTC detecting condition	Possible cause
P1211 1211	TCS control unit	ECM receives a malfunction information from “ABS actuator and electric unit (control unit)”.	<ul style="list-style-type: none">● ABS actuator and electric unit (control unit)● TCS related parts

DTC Confirmation Procedure

UBS00PC1

TESTING CONDITION:

Before performing the following procedure, confirm that battery voltage is more than 10.5V at idle.

④ WITH CONSULT-II

1. Turn ignition switch ON.
2. Select “DATA MONITOR” mode with CONSULT-II.
3. Start engine and let it idle for at least 60 seconds.
4. If 1st trip DTC is detected, go to [EC-542, "Diagnostic Procedure"](#)

DATA MONITOR	
MONITOR	NO DTC
ENG SPEED	XXX rpm

SEF058Y

④ WITH GST

Follow the procedure “WITH CONSULT-II” above.

Diagnostic Procedure

UBS00PC2

Go to [BRC-10, "TROUBLE DIAGNOSIS"](#) or [BRC-55, "TROUBLE DIAGNOSIS"](#) .

DTC P1212 TCS COMMUNICATION LINE

DTC P1212 TCS COMMUNICATION LINE

PF:47850

Description

UBS00PC3

NOTE:

- If DTC P1212 is displayed with DTC U1000 or U1001, first perform the trouble diagnosis for DTC U1000, U1001. Refer to [EC-159, "DTC U1000, U1001 CAN COMMUNICATION LINE"](#).
- If DTC P1212 is displayed with DTC U1010, first perform the trouble diagnosis for DTC U1010. Refer to [EC-162, "DTC U1010 CAN COMMUNICATION"](#).

This CAN communication line is used to control the smooth engine operation during the TCS operation. Pulse signals are exchanged between ECM and "ABS actuator and electric unit (control unit)".

Be sure to erase the malfunction information such as DTC not only for "ABS actuator and electric unit (control unit)" but also for ECM after TCS related repair.

On Board Diagnosis Logic

UBS00PC4

The MIL will not light up for this self-diagnosis.

Freeze frame data is not stored in the ECM for this self-diagnosis.

DTC No.	Trouble diagnosis name	DTC detecting condition	Possible cause
P1212 1212	TCS communication line	ECM can not receive the information from "ABS actuator and electric unit (control unit)" continuously.	<ul style="list-style-type: none"> ● Harness or connectors (The CAN communication line is open or shorted.) ● ABS actuator and electric unit (control unit). ● Dead (Weak) battery

DTC Confirmation Procedure

UBS00PC5

TESTING CONDITION:

Before performing the following procedure, confirm that battery voltage is more than 10.5V at idle.

④ WITH CONSULT-II

1. Turn ignition switch ON.
2. Select "DATA MONITOR" mode with CONSULT-II.
3. Start engine and let it idle for at least 10 seconds.
4. If 1st trip DTC is detected, go to [EC-543, "Diagnostic Procedure"](#)

DATA MONITOR	
MONITOR	NO DTC
ENG SPEED	XXX rpm

SEF058Y

④ WITH GST

Follow the procedure "WITH CONSULT-II" above.

Diagnostic Procedure

UBS00PC6

Go to [BRC-10, "TROUBLE DIAGNOSIS"](#) or [BRC-55, "TROUBLE DIAGNOSIS"](#).

DTC P1217 ENGINE OVER TEMPERATURE

PF0:0000

UBS00PC7

DTC P1217 ENGINE OVER TEMPERATURE

Description SYSTEM DESCRIPTION

NOTE:

- If DTC P1217 is displayed with DTC U1000 or U1001, first perform the trouble diagnosis for DTC U1000, U1001. Refer to [EC-159, "DTC U1000, U1001 CAN COMMUNICATION LINE"](#).
- If DTC P1217 is displayed with DTC U1010, first perform the trouble diagnosis for DTC U1010. Refer to [EC-162, "DTC U1010 CAN COMMUNICATION"](#).

Cooling Fan Control

Sensor	Input Signal to ECM	ECM function	Actuator
Crankshaft position sensor (POS) Camshaft position sensor (PHASE)	Engine speed*1	Cooling fan control	IPDM E/R (Cooling fan relay)
Battery	Battery voltage*1		
Wheel sensor	Vehicle speed*2		
Engine coolant temperature sensor	Engine coolant temperature		
Air conditioner switch	Air conditioner ON signal*2		
Refrigerant pressure sensor	Refrigerant pressure		

*1: The ECM determines the start signal status by the signals of engine speed and battery voltage.

*2: This signal is sent to ECM through CAN communication line.

The ECM controls the cooling fan corresponding to the vehicle speed, engine coolant temperature, refrigerant pressure, and air conditioner ON signal. The control system has 4-step control [HIGH/MIDDLE/LOW/OFF].

Cooling Fan Operation

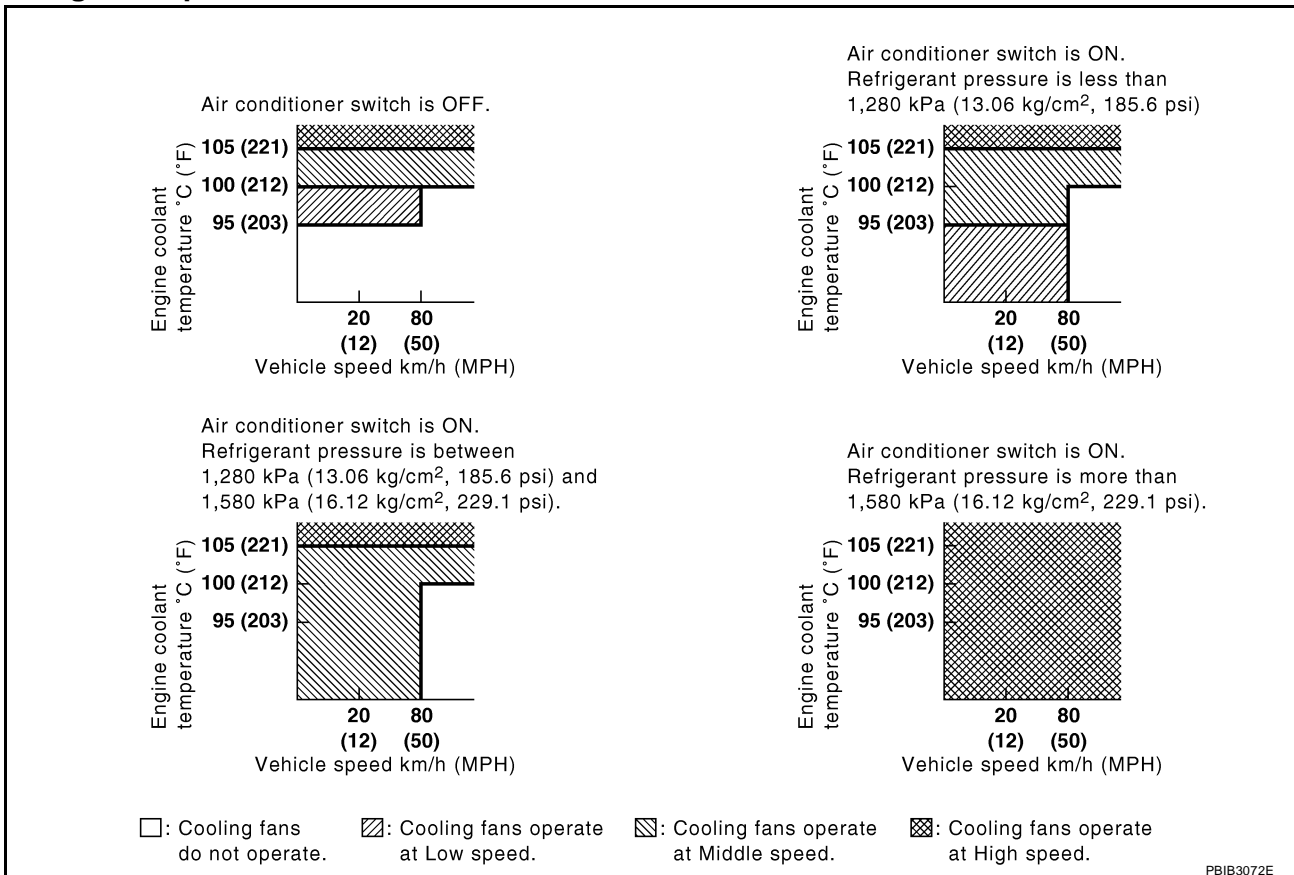

DTC P1217 ENGINE OVER TEMPERATURE

Cooling Fan Relay Operation

The ECM controls cooling fan relays in the IPDM E/R through CAN communication line.

Cooling fan speed	Cooling fan relay		
	1	2	3
Stop (OFF)	OFF	OFF	OFF
Low (LOW)	OFF	ON	OFF
Middle (MID)	ON	OFF	OFF
High (HI)	ON	OFF	ON

COMPONENT DESCRIPTION

Cooling Fan Motor

The cooling fan operates at each speed when the current flows in the cooling fan motor as follows.

Cooling fan speed	Cooling fan motor terminals	
	(+)	(-)
Middle (MID)	1	3 and 4
	2	3 and 4
	1 and 2	3
	1 and 2	4
High (HI)	1 and 2	3 and 4

The cooling fan operates at low (LOW) speed when cooling fan motors-1 and -2 are circuited in series under middle speed condition.

CONSULT-II Reference Value in Data Monitor Mode

UBS00PC8

Specification data are reference values.

MONITOR ITEM	CONDITION	SPECIFICATION	
AIR COND SIG	● Engine: After warming up, idle the engine	Air conditioner switch: OFF	OFF
		Air conditioner switch: ON (Compressor operates.)	ON
COOLING FAN	● Engine: After warming up, idle the engine ● Air conditioner switch: OFF	Engine coolant temperature: 94°C (201°F) or less	OFF
		Engine coolant temperature: Between 95°C (203°F) and 99°C (210°F)	LOW
		Engine coolant temperature: Between 100°C (212°F) and 104°C (219°F)	MID
		Engine coolant temperature: 105°C (221°F) or more	HI

DTC P1217 ENGINE OVER TEMPERATURE

UBS00PC9

On Board Diagnosis Logic

If the cooling fan or another component in the cooling system malfunctions, engine coolant temperature will rise.

When the engine coolant temperature reaches an abnormally high temperature condition, a malfunction is indicated.

This self-diagnosis has the one trip detection logic.

DTC No.	Trouble diagnosis name	DTC detecting condition	Possible cause
P1217 1217	Engine over temperature (Overheat)	<ul style="list-style-type: none">● Cooling fan does not operate properly (Overheat).● Cooling fan system does not operate properly (Overheat).● Engine coolant was not added to the system using the proper filling method.● Engine coolant is not within the specified range.	<ul style="list-style-type: none">● Harness or connectors (The cooling fan circuit is open or shorted.)● IPDM E/R (Cooling fan relay)● Cooling fan● Radiator hose● Radiator● Radiator cap● Water pump● Thermostat <p>For more information, refer to EC-553, "Main 12 Causes of Overheating" .</p>

CAUTION:

When a malfunction is indicated, be sure to replace the coolant. Refer to [CO-10, "Changing Engine Coolant"](#) . Also, replace the engine oil. Refer to [LU-9, "Changing Engine Oil"](#) .

1. Fill radiator with coolant up to specified level with a filling speed of 2 liters per minute. Be sure to use coolant with the proper mixture ratio. Refer to [MA-10, "ANTI-FREEZE COOLANT MIXTURE RATIO"](#) .
2. After refilling coolant, run engine to ensure that no water-flow noise is emitted.

DTC P1217 ENGINE OVER TEMPERATURE

UBS00PCA

Overall Function Check

Use this procedure to check the overall function of the cooling fan. During this check, a DTC might not be confirmed.

WARNING:

Never remove the radiator cap when the engine is hot. Serious burns could be caused by high pressure fluid escaping from the radiator.

Wrap a thick cloth around cap. Carefully remove the cap by turning it a quarter turn to allow built-up pressure to escape. Then turn the cap all the way off.

WITH CONSULT-II

1. Check the coolant level in the reservoir tank and radiator.
Allow engine to cool before checking coolant level.
If the coolant level in the reservoir tank and/or radiator is below the proper range, skip the following steps and go to [EC-550, "Diagnostic Procedure"](#).
2. Confirm whether customer filled the coolant or not. If customer filled the coolant, skip the following steps and go to [EC-550, "Diagnostic Procedure"](#).
3. Turn ignition switch ON.
4. Perform "COOLING FAN" in "ACTIVE TEST" mode with CONSULT-II.
5. If the results are NG, go to [EC-550, "Diagnostic Procedure"](#).

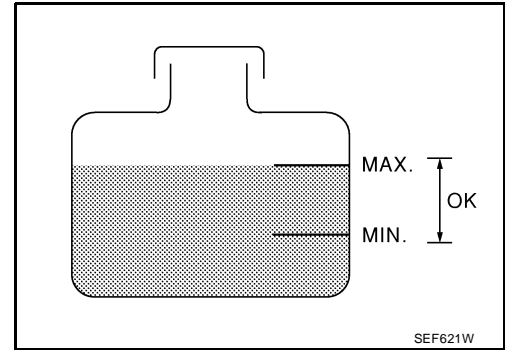

ACTIVE TEST	
COOLING FAN	OFF
MONITOR	
COOLANT TEMP/S	XXX °C

SEF646X

WITH GST

1. Check the coolant level in the reservoir tank and radiator.
Allow engine to cool before checking coolant level.
If the coolant level in the reservoir tank and/or radiator is below the proper range, skip the following steps and go to [EC-550, "Diagnostic Procedure"](#).
2. Confirm whether customer filled the coolant or not. If customer filled the coolant, skip the following steps and go to [EC-550, "Diagnostic Procedure"](#).
3. Perform IPDM E/R auto active test and check cooling fan motors operation, refer to [PG-23, "Auto Active Test"](#).
4. If NG, go to [EC-550, "Diagnostic Procedure"](#).

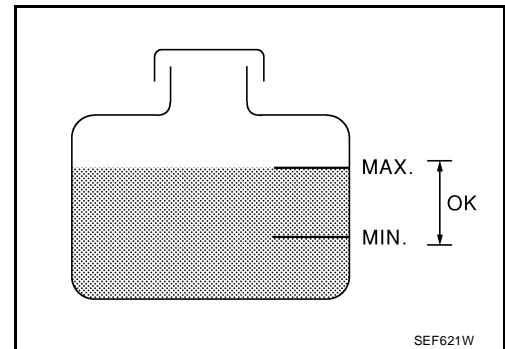



DTC P1217 ENGINE OVER TEMPERATURE

Wiring Diagram

UBS00PCB

EC-COOL/F-01

-  : DETECTABLE LINE FOR DTC
-  : NON-DETECTABLE LINE FOR DTC
-  : DATA LINE

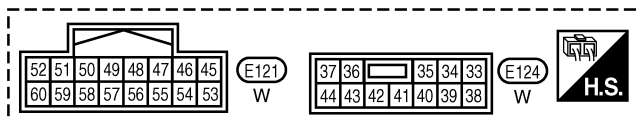
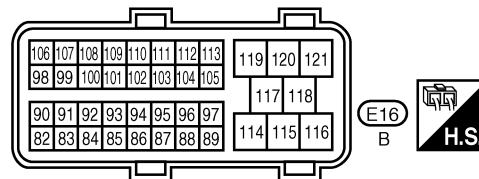
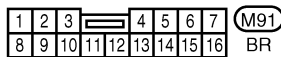
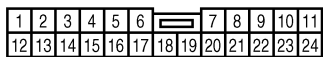
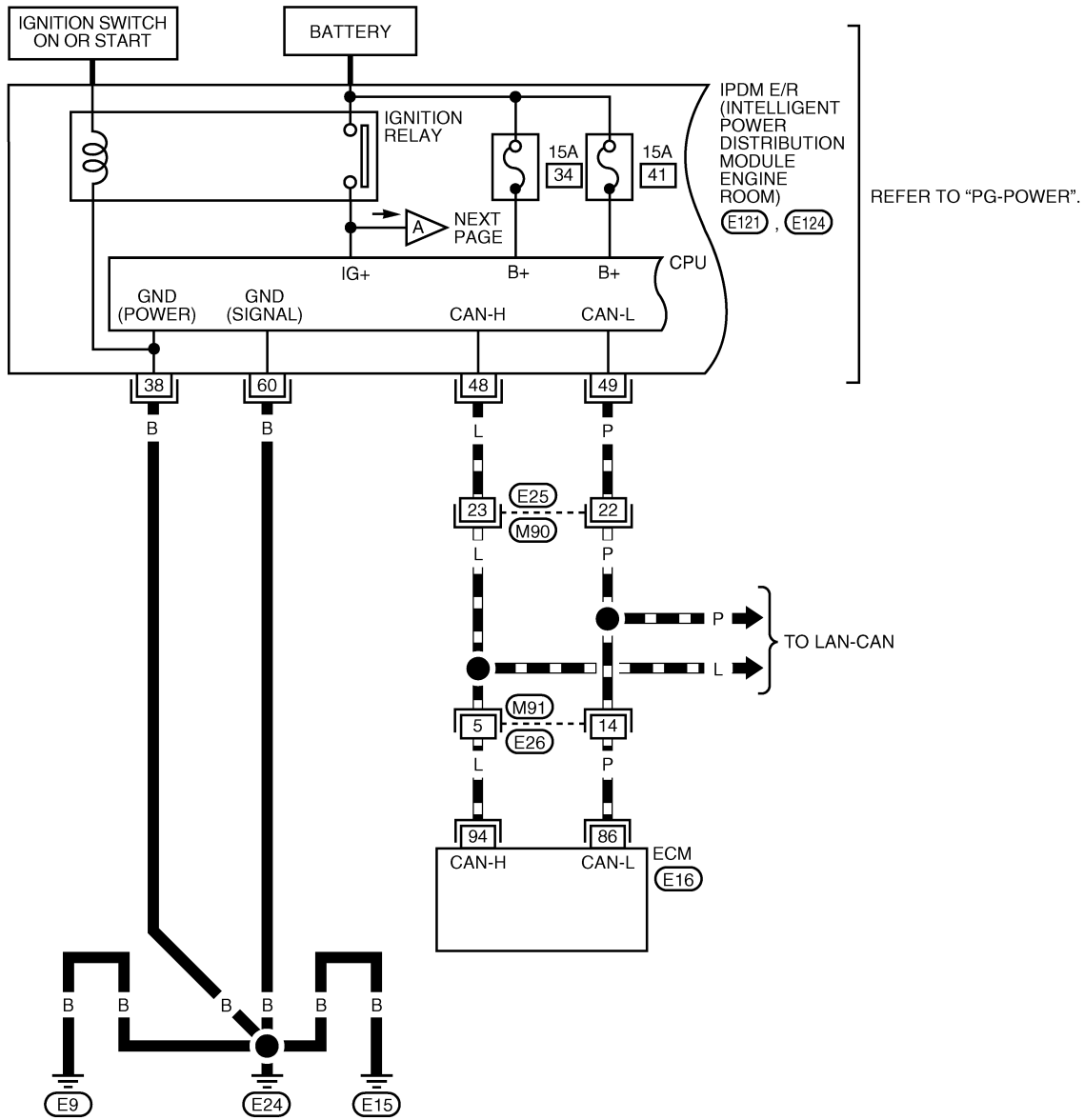

BBWA2528E

DTC P1217 ENGINE OVER TEMPERATURE

EC-COOL/F-02

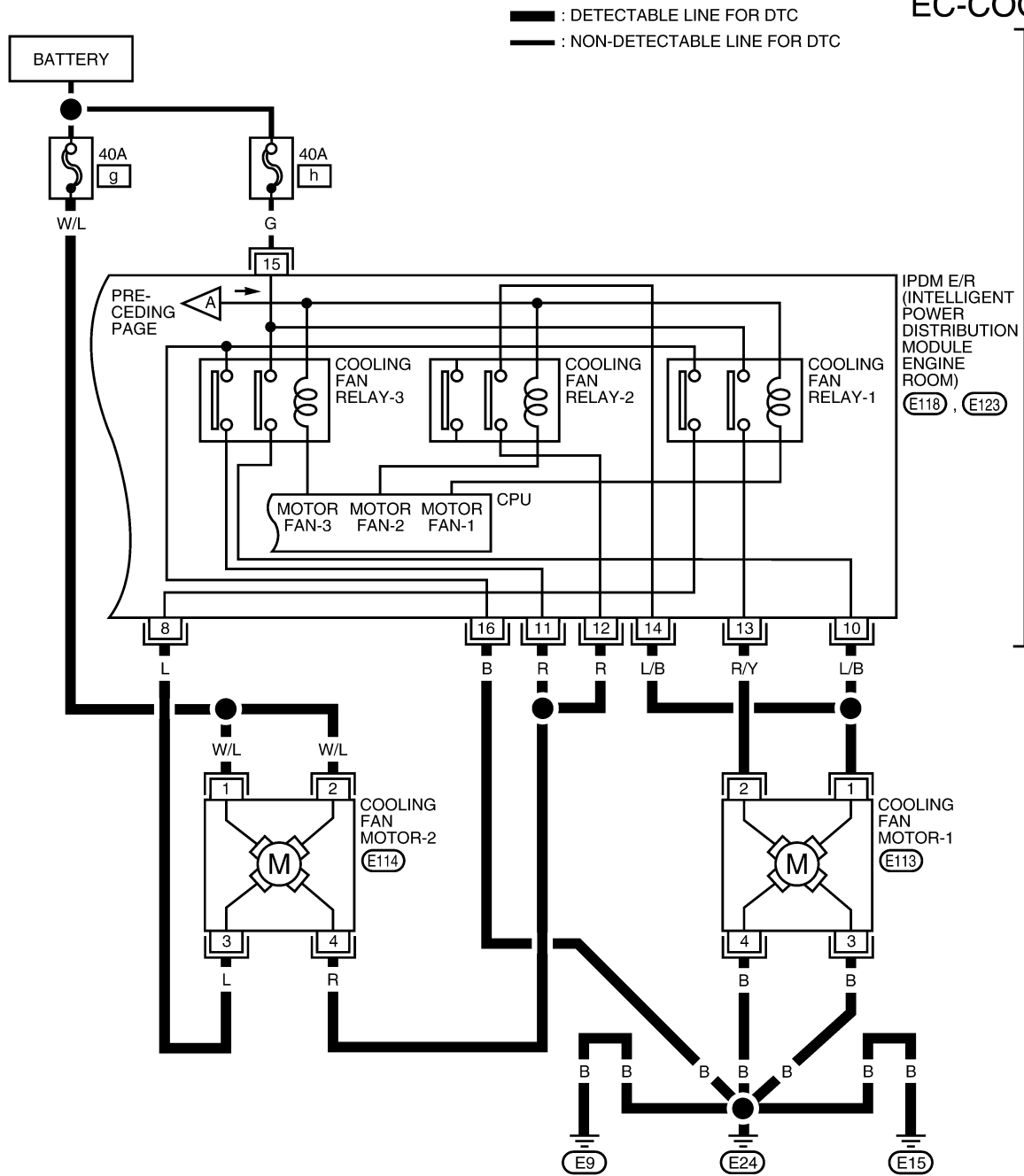

REFER TO "PG-POWER".

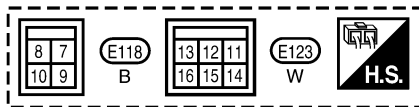
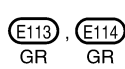

A
EC
C
D
E
F
G
H
I
J
K
L
M

DTC P1217 ENGINE OVER TEMPERATURE

UBS00PCC

Diagnostic Procedure

1. INSPECTION START

Do you have CONSULT-II?

Yes or No

- Yes >> GO TO 2.
- No >> GO TO 3.

2. CHECK COOLING FAN OPERATION

With CONSULT-II

1. Start engine and let it idle.
2. Select "COOLING FAN" in "ACTIVE TEST" mode with CONSULT-II.
3. Make sure that cooling fans-1 and -2 operate at each speed (LOW/MID/HI).

OK or NG

- OK >> GO TO 4.
- NG >> Check cooling fan control circuit. (Go to [EC-551](#), "[COOLING FAN CONTROL CIRCUIT](#)".)

ACTIVE TEST	
COOLING FAN	LOW
MONITOR	
COOLAN TEMP/S	XXX °C

SEF784Z

3. CHECK COOLING FAN OPERATION

Without CONSULT-II

1. Perform IPDM E/R auto active test and check cooling fan motors operation, refer to [PG-23](#), "[Auto Active Test](#)".
2. Make sure that cooling fans-1 and -2 operate at each speed (Low/Middle/High).

OK or NG

- OK >> GO TO 4.
- NG >> Check cooling fan control circuit. (Go to [EC-551](#), "[COOLING FAN CONTROL CIRCUIT](#)".)

4. CHECK COOLING SYSTEM FOR LEAK

[CO-9, "CHECKING COOLING SYSTEM FOR LEAKS"](#)

OK or NG

- OK >> GO TO 5.
- NG >> Check the following for leak. Refer to [CO-9, "CHECKING COOLING SYSTEM FOR LEAKS"](#).
 - Hose
 - Radiator
 - Water pump

5. CHECK RADIATOR CAP

[CO-9, "CHECKING RADIATOR CAP"](#)

OK or NG

- OK >> GO TO 6.
- NG >> Replace radiator cap.

DTC P1217 ENGINE OVER TEMPERATURE

6. CHECK COMPONENT PARTS

Check the following.

Thermostat. Refer to [CO-23, "THERMOSTAT AND THERMOSTAT HOUSING"](#).

Engine coolant temperature sensor. Refer to [EC-233, "Component Inspection"](#).

OK or NG

OK >> GO TO 7.

NG >> Replace engine coolant temperature sensor.

7. CHECK MAIN 12 CAUSES

If the cause cannot be isolated, go to [EC-553, "Main 12 Causes of Overheating"](#).

>> INSPECTION END

COOLING FAN CONTROL CIRCUIT

1. CHECK IPDM E/R POWER SUPPLY CIRCUIT

1. Turn ignition switch OFF.
2. Disconnect IPDM E/R harness connector E123.
3. Check voltage between IPDM E/R terminal 15 and ground with CONSULT-II or tester.

Voltage: Battery voltage

OK or NG

OK >> GO TO 3.

NG >> GO TO 2.

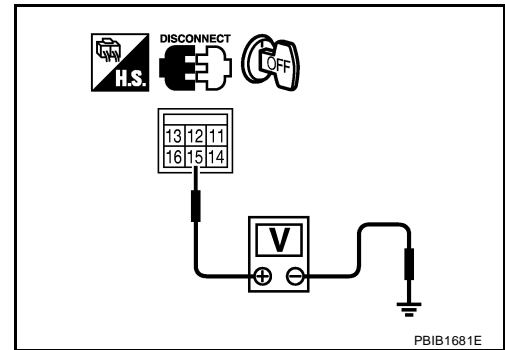

2. DETECT MALFUNCTIONING PART

Check the following.

- 40A fusible link
- Harness for open or short between IPDM E/R and battery

>> Repair open circuit or short to ground or short to power in harness or connectors.

3. CHECK IPDM E/R GROUND CIRCUIT FOR OPEN AND SHORT

1. Disconnect IPDM E/R harness connector E121, E123 and E124.
2. Check harness continuity between IPDM E/R terminal 16, 38, 60 and ground. Refer to Wiring Diagram.

Continuity should exist.

3. Also check harness for short to power.

OK or NG

OK >> GO TO 4.

NG >> Repair open circuit or short to power in harness or connectors.

DTC P1217 ENGINE OVER TEMPERATURE

4. CHECK COOLING FAN MOTOR-2 CIRCUIT FOR OPEN AND SHORT-I

1. Disconnect cooling fan motor-2 harness connector.

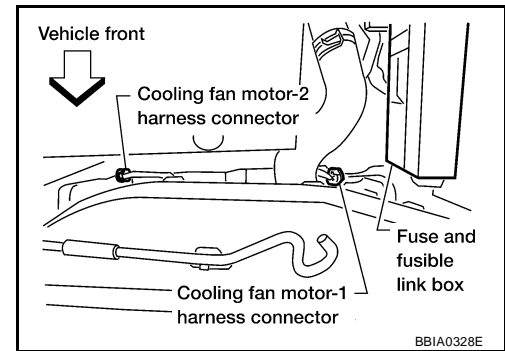

2. Check voltage between cooling fan motor-2 terminals 1, 2 and ground with CONSULT-II or tester.

Voltage: Battery voltage

OK or NG

- OK >> GO TO 6.
- NG >> GO TO 5.

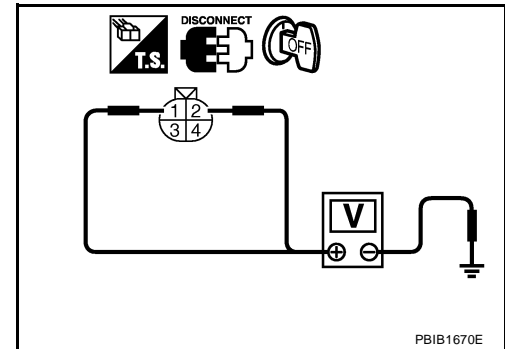

5. DETECT MALFUNCTIONING PART

Check the following.

- 40A fusible link
- Harness for open or short between cooling fan motor-2 and battery

>> Repair open circuit or short to ground or short to power in harness or connectors.

6. CHECK COOLING FAN MOTOR-2 CIRCUIT FOR OPEN AND SHORT-II

1. Disconnect IPDM E/R harness connector E118.
2. Check harness continuity between the following terminals.
Cooling fan motor-2 terminal 3 and IPDM E/R terminal 8,
Cooling fan motor-2 terminal 4 and IPDM E/R terminals 11, 12.
Refer to Wiring Diagram.

Continuity should exist.

3. Also check harness for short to ground and short to power.

OK or NG

- OK >> GO TO 7.
- NG >> Repair open circuit or short to ground or short to power in harness or connectors.

DTC P1217 ENGINE OVER TEMPERATURE

7. CHECK COOLING FAN MOTOR-1 CIRCUIT FOR OPEN AND SHORT-I

1. Disconnect cooling fan motor-1 harness connector.
2. Check harness continuity between cooling fan motor-1 terminals 3, 4 and ground.
Refer to Wiring diagram.

Continuity should exist.

3. Also check harness for short to power.

OK or NG

OK >> GO TO 8.

NG >> Repair open circuit or short to power in harness or connectors.

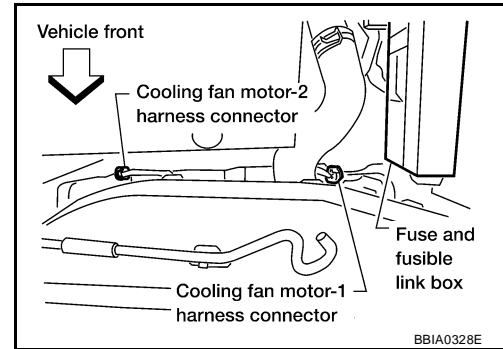

8. CHECK COOLING FAN MOTOR-1 CIRCUIT FOR OPEN AND SHORT-II

1. Check harness continuity between the following terminals.
Cooling fan motor-1 terminal 1 and IPDM E/R terminal 10, 14,
Cooling fan motor-1 terminal 2 and IPDM E/R terminal 13.
Refer to Wiring Diagram.

Continuity should exist.

2. Also check harness for short to ground and short to power.

OK or NG

OK >> GO TO 9.

NG >> Repair open circuit or short to ground or short to power in harness or connectors.

9. CHECK COOLING FAN MOTORS

Refer to [EC-554, "Component Inspection"](#) .

OK or NG

OK >> GO TO 10.

NG >> Replace cooling fan motors.

10. CHECK INTERMITTENT INCIDENT

Perform [EC-149, "TROUBLE DIAGNOSIS FOR INTERMITTENT INCIDENT"](#) .

OK or NG

OK >> Replace IPDM E/R. Refer to [PG-18, "IPDM E/R \(INTELLIGENT POWER DISTRIBUTION MODULE ENGINE ROOM\)"](#) .

NG >> Repair or replace harness or connector.

Main 12 Causes of Overheating

UBS00PCD

Engine	Step	Inspection item	Equipment	Standard	Reference page
OFF	1	<ul style="list-style-type: none"> ● Blocked radiator ● Blocked condenser ● Blocked radiator grille ● Blocked bumper 	<ul style="list-style-type: none"> ● Visual 	No blocking	—
	2	<ul style="list-style-type: none"> ● Coolant mixture 	<ul style="list-style-type: none"> ● Coolant tester 	50 - 50% coolant mixture	MA-10
	3	<ul style="list-style-type: none"> ● Coolant level 	<ul style="list-style-type: none"> ● Visual 	Coolant up to MAX level in reservoir tank and radiator filler neck	CO-9
	4	<ul style="list-style-type: none"> ● Radiator cap 	<ul style="list-style-type: none"> ● Pressure tester 	59 - 98 kPa (0.6 - 1.0 kg/cm ² , 9 - 14 psi) (Limit)	CO-15
ON*2	5	<ul style="list-style-type: none"> ● Coolant leaks 	<ul style="list-style-type: none"> ● Visual 	No leaks	CO-9

DTC P1217 ENGINE OVER TEMPERATURE

Engine	Step	Inspection item	Equipment	Standard	Reference page
ON*2	6	● Thermostat	● Touch the upper and lower radiator hoses	Both hoses should be hot	CO-23
ON*1	7	● Cooling fan	● CONSULT-II	Operating	See trouble diagnosis for DTC P1217 (EC-544).
OFF	8	● Combustion gas leak	● Color checker chemical tester 4 Gas analyzer	Negative	—
ON*3	9	● Coolant temperature gauge	● Visual	Gauge less than 3/4 when driving	—
		● Coolant overflow to reservoir tank	● Visual	No overflow during driving and idling	CO-9
OFF*4	10	● Coolant return from reservoir tank to radiator	● Visual	Should be initial level in reservoir tank	CO-9
OFF	11	● Cylinder head	● Straight gauge feeler gauge	0.1 mm (0.004 in) Maximum distortion (warping)	EM-96
	12	● Cylinder block and pistons	● Visual	No scuffing on cylinder walls or piston	EM-118

*1: Turn the ignition switch ON.

*2: Engine running at 3,000 rpm for 10 minutes.

*3: Drive at 90 km/h (55 MPH) for 30 minutes and then let idle for 10 minutes.

*4: After 60 minutes of cool down time.

For more information, refer to [CO-6, "OVERHEATING CAUSE ANALYSIS"](#).

Component Inspection COOLING FAN MOTORS-1 AND -2

UBS00PCE

1. Disconnect cooling fan motor harness connectors.
2. Supply cooling fan motor terminals with battery voltage and check operation.

Cooling fan speed	Cooling fan motor terminals	
	(+)	(-)
Middle (MID)	1	3 and 4
	2	3 and 4
	1 and 2	3
	1 and 2	4
High (HI)	1 and 2	3 and 4

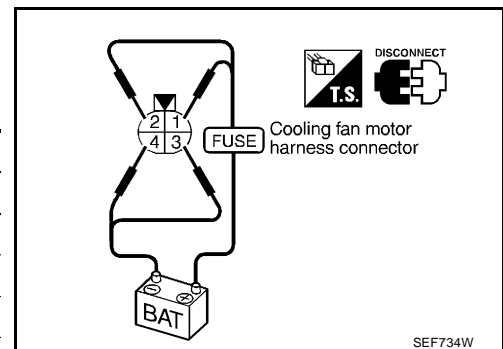

Cooling fan motor should operate.

If NG, replace cooling fan motor.

DTC P1225 TP SENSOR

PF16119

DTC P1225 TP SENSOR

Component Description

UBS00PCF

Electric throttle control actuator consists of throttle control motor, throttle position sensor, etc. The throttle position sensor responds to the throttle valve movement.

The throttle position sensor has the two sensors. These sensors are a kind of potentiometers which transform the throttle valve position into output voltage, and emit the voltage signal to the ECM. In addition, these sensors detect the opening and closing speed of the throttle valve and feed the voltage signals to the ECM. The ECM judges the current opening angle of the throttle valve from these signals and the ECM controls the throttle control motor to make the throttle valve opening angle properly in response to driving condition.

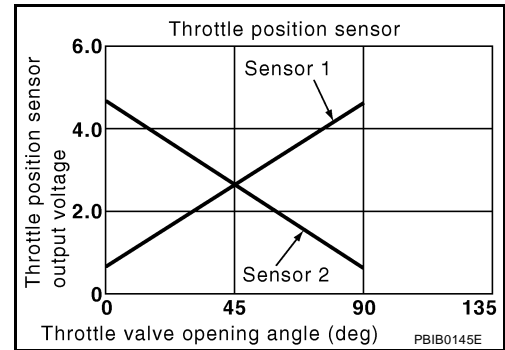

On Board Diagnosis Logic

UBS00PCG

The MIL will not light up for this diagnosis.

DTC No.	Trouble diagnosis name	DTC detecting condition	Possible cause
P1225 1225	Closed throttle position learning performance	Closed throttle position learning value is excessively low.	<ul style="list-style-type: none"> Electric throttle control actuator (TP sensor 1 and 2)

DTC Confirmation Procedure

UBS00PCH

NOTE:

If DTC Confirmation Procedure has been previously conducted, always turn ignition switch OFF and wait at least 10 seconds before conducting the next test.

TESTING CONDITION:

Before performing the following procedure, confirm that battery voltage is more than 10V at idle.

WITH CONSULT-II

- Turn ignition switch ON.
- Select "DATA MONITOR" mode with CONSULT-II.
- Turn ignition switch OFF and wait at least 10 seconds.
- Turn ignition switch ON.
- If 1st trip DTC is detected, go to [EC-556, "Diagnostic Procedure"](#)

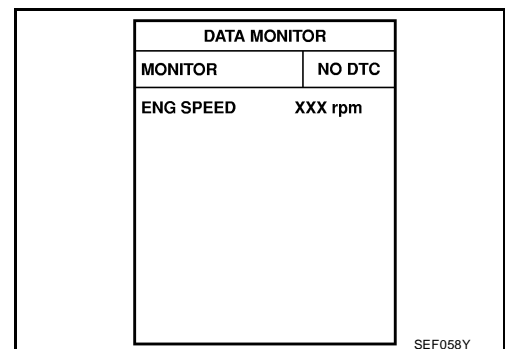

WITH GST

Follow the procedure "WITH CONSULT-II" above.

DTC P1225 TP SENSOR

UBS00PCI

Diagnostic Procedure

1. CHECK ELECTRIC THROTTLE CONTROL ACTUATOR VISUALLY

1. Turn ignition switch OFF.
2. Remove the intake air duct.
3. Check if foreign matter is caught between the throttle valve and the housing.

OK or NG

- OK >> GO TO 2.
NG >> Remove the foreign matter and clean the electric throttle control actuator inside.

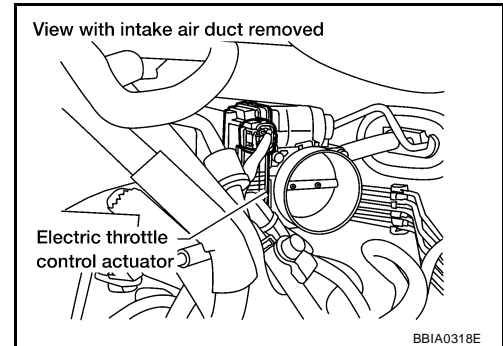

2. REPLACE ELECTRIC THROTTLE CONTROL ACTUATOR

1. Replace the electric throttle control actuator.
2. Perform [EC-80, "Throttle Valve Closed Position Learning"](#) .
3. Perform [EC-80, "Idle Air Volume Learning"](#) .

>> INSPECTION END

Removal and Installation ELECTRIC THROTTLE CONTROL ACTUATOR

UBS00PCJ

Refer to [EM-18, "INTAKE MANIFOLD COLLECTOR"](#) .

DTC P1226 TP SENSOR

PF16119

DTC P1226 TP SENSOR

Component Description

UBS00PCK

Electric throttle control actuator consists of throttle control motor, throttle position sensor, etc. The throttle position sensor responds to the throttle valve movement.

The throttle position sensor has the two sensors. These sensors are a kind of potentiometers which transform the throttle valve position into output voltage, and emit the voltage signal to the ECM. In addition, these sensors detect the opening and closing speed of the throttle valve and feed the voltage signals to the ECM. The ECM judges the current opening angle of the throttle valve from these signals and the ECM controls the throttle control motor to make the throttle valve opening angle properly in response to driving condition.

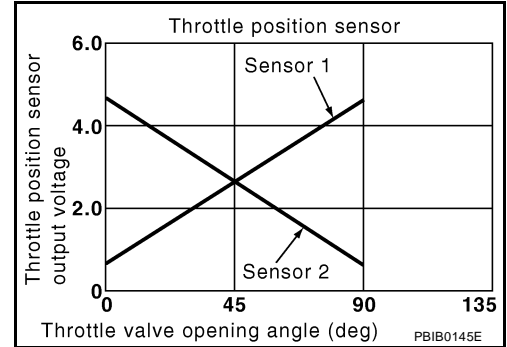

On Board Diagnosis Logic

UBS00PCL

The MIL will not light up for this diagnosis.

DTC No.	Trouble diagnosis name	DTC detecting condition	Possible cause
P1226 1226	Closed throttle position learning performance	Closed throttle position learning is not performed successfully, repeatedly.	● Electric throttle control actuator (TP sensor 1 and 2)

DTC Confirmation Procedure

UBS00PCM

NOTE:

If DTC Confirmation Procedure has been previously conducted, always turn ignition switch OFF and wait at least 10 seconds before conducting the next test.

TESTING CONDITION:

Before performing the following procedure, confirm that battery voltage is more than 10V at idle.

WITH CONSULT-II

1. Turn ignition switch ON.
2. Select "DATA MONITOR" mode with CONSULT-II.
3. Turn ignition switch OFF and wait at least 10 seconds.
4. Turn ignition switch ON.
5. Repeat step 3 to 4 for 32 times.
6. If 1st trip DTC is detected, go to [EC-558, "Diagnostic Procedure"](#)

DATA MONITOR	
MONITOR	NO DTC
ENG SPEED	XXX rpm

SEF058Y

WITH GST

Follow the procedure "WITH CONSULT-II" above.

DTC P1226 TP SENSOR

UBS00PCN

Diagnostic Procedure

1. CHECK ELECTRIC THROTTLE CONTROL ACTUATOR VISUALLY

1. Turn ignition switch OFF.
2. Remove the intake air duct.
3. Check if foreign matter is caught between the throttle valve and the housing.

OK or NG

- OK >> GO TO 2.
NG >> Remove the foreign matter and clean the electric throttle control actuator inside.

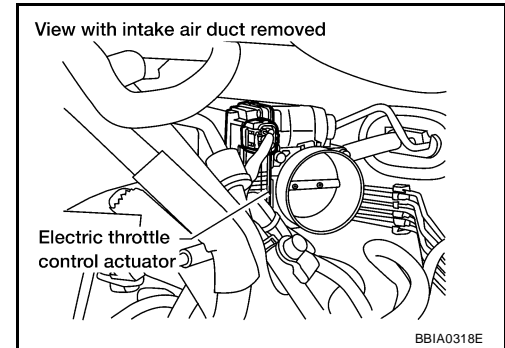

2. REPLACE ELECTRIC THROTTLE CONTROL ACTUATOR

1. Replace the electric throttle control actuator.
2. Perform [EC-80, "Throttle Valve Closed Position Learning"](#) .
3. Perform [EC-80, "Idle Air Volume Learning"](#) .

>> INSPECTION END

Removal and Installation ELECTRIC THROTTLE CONTROL ACTUATOR

UBS00PCO

Refer to [EM-18, "INTAKE MANIFOLD COLLECTOR"](#) .

DTC P1402 EGR FUNCTION

PFP:14710

UBS00PCP

DTC P1402 EGR FUNCTION

Description SYSTEM DESCRIPTION

Sensor	Input Signal to ECM	ECM function	Actuator
Camshaft position sensor (PHASE)	Engine speed*2 Piston position	EGR volume control	EGR volume control valve
Crankshaft position sensor (POS)			
Mass air flow sensor	Amount of intake air		
Engine coolant temperature sensor	Engine coolant temperature		
Throttle position sensor	Throttle position		
Accelerator pedal position sensor	Accelerator pedal position		
Park/neutral position (PNP) switch	Gear position		
Battery	Battery voltage*2		
Air conditioner switch	Air conditioner operation *1		
Power steering pressure sensor	Power steering operation		
Electrical load	Electrical load signal *1		
Wheel sensor	Vehicle speed *1		
TCM	Gear position, shifting signal *1		

*1: This signal is sent to the ECM through CAN communication line.

*2: ECM determines the start signal status by the signals of engine speed and battery voltage.

This system controls flow rate of EGR led from exhaust manifold to intake manifold. The opening of the EGR by-pass passage in the EGR volume control valve changes to control the flow rate. A built-in step motor moves the valve in steps corresponding to the ECM output pulses. The opening of the valve varies for optimum engine control. The optimum value stored in the ECM is determined by considering various engine conditions. The EGR volume control valve remains closed under the following conditions.

- Engine stopped
- Engine starting
- Engine idling
- Low engine coolant temperature
- Excessively high engine coolant temperature
- High engine speed
- Wide open throttle
- Low battery voltage

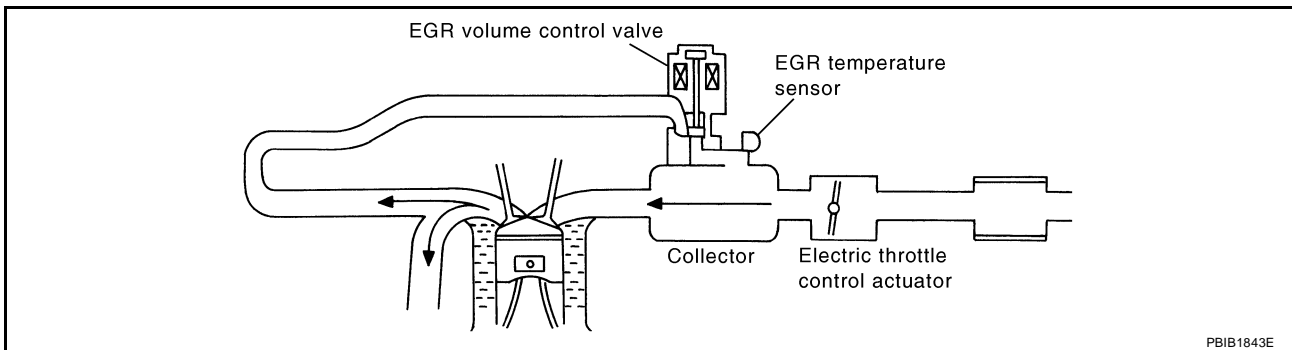

DTC P1402 EGR FUNCTION

COMPONENT DESCRIPTION

EGR Volume Control Valve

The EGR volume control valve uses a step motor to control the flow rate of EGR from exhaust manifold. This motor has four winding phases. It operates according to the output pulse signal of the ECM. Two windings are turned ON and OFF in sequence. Each time an ON pulse is issued, the valve opens or closes, changing the flow rate. When no change in the flow rate is needed, the ECM does not issue the pulse signal. A certain voltage signal is issued so that the valve remains at that particular opening.

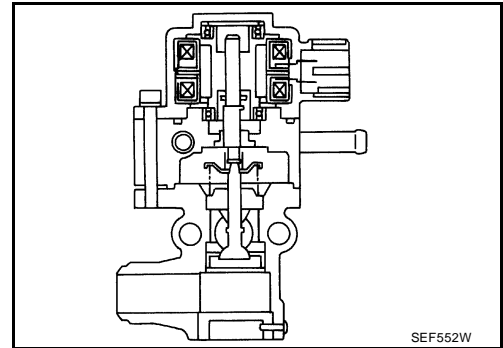

EGR Temperature Sensor

The EGR temperature sensor detects temperature changes in the EGR passageway. When the EGR volume control valve opens, hot exhaust gases flow, and the temperature in the passageway changes. The EGR temperature sensor is a thermistor that modifies a voltage signal sent from the ECM. This modified signal then returns to the ECM as an input signal. As the temperature increases, EGR temperature sensor resistance decreases.

This sensor is not directly used to control the engine system. It is used only for the on board diagnosis.

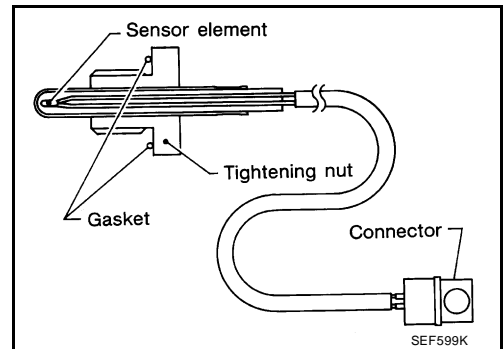

<Reference data>

EGR temperature °C (°F)	Voltage* V	Resistance MΩ
0 (32)	4.59	0.73 - 0.88
50 (122)	2.32	0.074 - 0.082
100 (212)	0.62	0.011 - 0.014

*: This data is reference value and is measured between ECM terminal 54 (EGR temperature sensor) and ground.

CAUTION:

Do not use ECM ground terminals when measuring input/output voltage. Doing so may damage the ECM's transistor. Use a ground other than ECM terminals, such as the ground.

When EGR system is operating.

Voltage: 0 - 1.5V

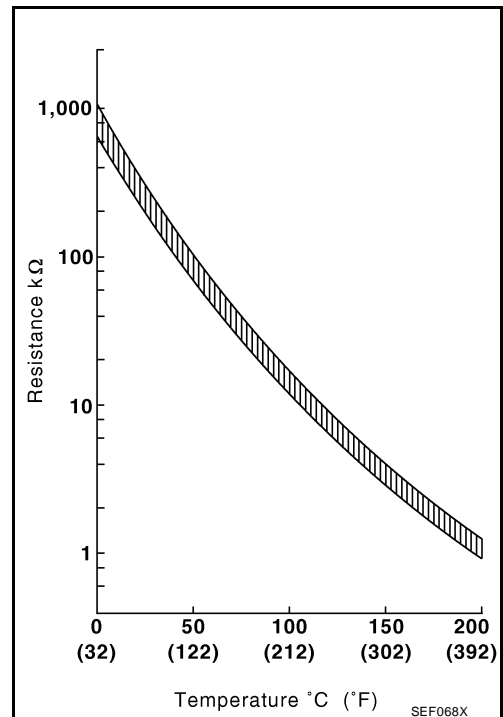

DTC P1402 EGR FUNCTION

CONSULT-II Reference Value in Data Monitor Mode

UBS00PCQ

Specification data are reference values.

MONITOR ITEM	CONDITION		SPECIFICATION
EGR TEMP SEN	● Engine: After warming up		Less than 4.5V
EGR VOL CON/V	● Engine: After warming up ● Air conditioner switch: OFF ● Shift lever: P or N ● No load	Idle	0 step
		Revsing engine up to 3,000 rpm quickly	10 - 55 step

On Board Diagnosis Logic

UBS00PCR

If the EGR temperature sensor detects EGR flow under the condition that does not call for EGR, a high-flow malfunction is diagnosed.

DTC No.	Trouble diagnosis name	DTC detecting condition	Possible cause
P1402 1402	EGR function (Open)	EGR flow is detected under the condition that does not call for EGR.	<ul style="list-style-type: none"> ● Harness or connectors (The EGR volume control valve circuit is open or shorted.) ● EGR volume control valve leaking or stuck open ● EGR temperature sensor

DTC Confirmation Procedure

UBS00PCS

NOTE:

- Diagnosis for this DTC will occur when engine coolant temperature is below 50 to 60°C (122 to 140°F). Therefore, it will be better to turn ignition switch ON (start engine) at the engine coolant temperature below 30°C (86°F) when starting DTC confirmation procedure.
- If DTC Confirmation Procedure has been previously conducted, always turn ignition switch OFF and wait at least 10 seconds before conducting the next test.

TESTING CONDITION:

- Always perform the test at a temperature above -10°C (14°F).
- Engine coolant temperature and EGR temperature must be verified in "DATA MONITOR" mode with CONSULT-II before starting DTC WORK SUPPORT test. If it is out of range below, the test cannot be conducted.

COOLAN TEMP/S : -10 to 50°C (14 to 122°F)*

EGR TEMP SEN : Less than 4.8V

If the values are out of the ranges indicated above, park the vehicle in a cool place and allow the engine temperature to stabilize. Do not attempt to reduce the engine coolant temperature or EGR temperature with a fan or means other than ambient air. Doing so may produce an inaccurate diagnostic result.

*: Although CONSULT-II screen displays "-10 to 40°C (14 to 104°F)" as a range of engine coolant temperature, ignore it.

DATA MONITOR	
MONITOR	NO DTC
COOLAN TEMP/S	XXX °C
EGR TEMP SEN	XXX V

SEF202Y

WITH CONSULT-II

1. Turn ignition switch OFF, and wait at least 10 seconds, and then turn ON.
2. Select "EGR SYSTEM P1402" of "EGR SYSTEM" in "DTC WORK SUPPORT" mode with CONSULT-II.
3. Touch "START".

DTC P1402 EGR FUNCTION

4. Start engine and let it idle until "TESTING" on CONSULT-II screen is turned to "COMPLETED". (It will take 80 seconds or more.)

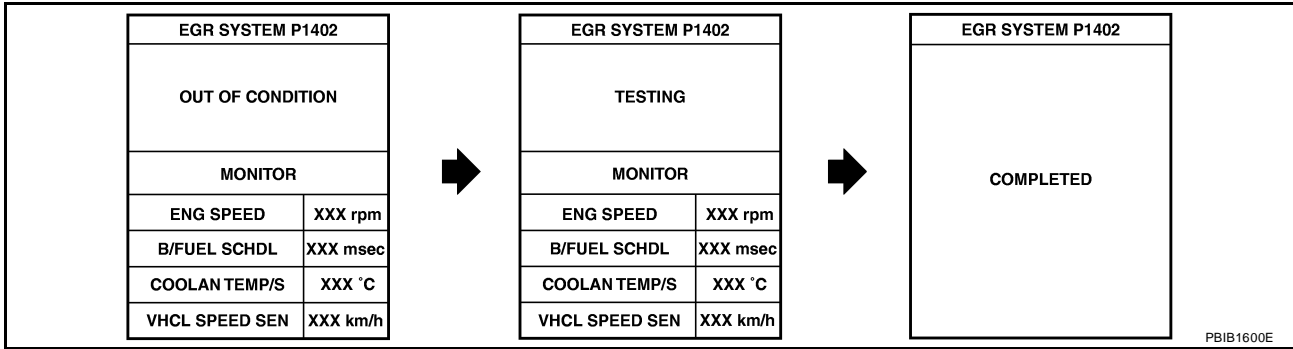

If "TESTING" is not displayed after 5 minutes, turn ignition OFF and cool the engine coolant temperature to the range of -10 to 50°C (14 to 122°F). Retry from step 1.

5. Make sure that "OK" is displayed after touching "SELF-DIAG RESULTS". If "NG" is displayed, refer to [EC-564, "Diagnostic Procedure"](#).

WITH GST

1. Turn ignition switch ON and select Service \$01 with GST.
2. Check that engine coolant temperature is within the range of -10 to 50°C (14 to 122°F).
3. Check that voltage between ECM terminal 54 (EGR temperature sensor signal) and ground is less than 4.8V.
4. Start engine and let it idle for at least 80 seconds.
5. Stop engine.
6. Turn ignition switch OFF, wait at least 10 seconds and then turn ON.
7. Select Service \$07 with GST.
8. If 1st trip DTC is detected, go to [EC-564, "Diagnostic Procedure"](#).

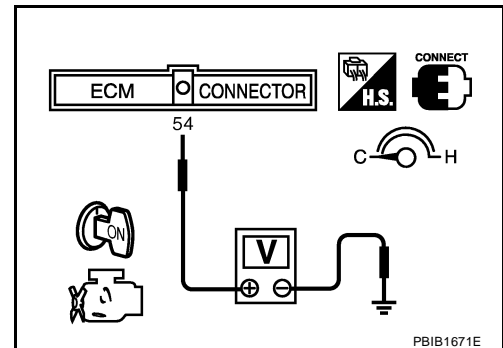

DTC P1402 EGR FUNCTION

Wiring Diagram

UBS00PCT

EC-EGRC1-01

A
EC
C
D
E
F
G
H
I
J
K
L
M

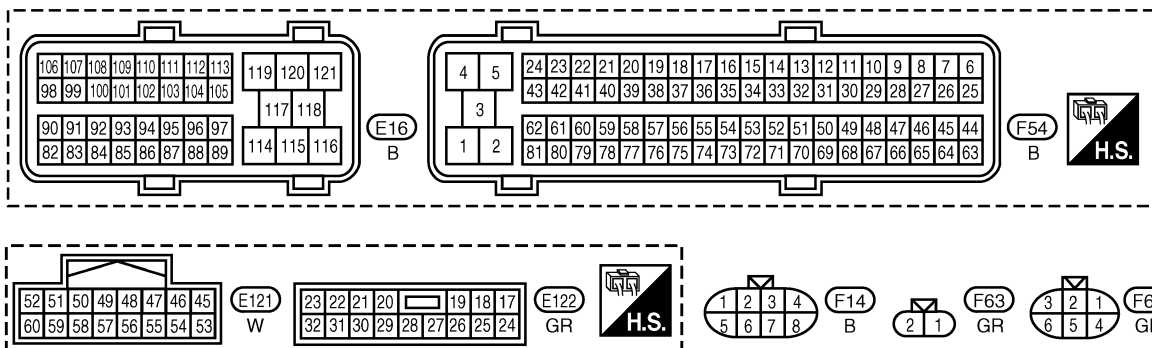
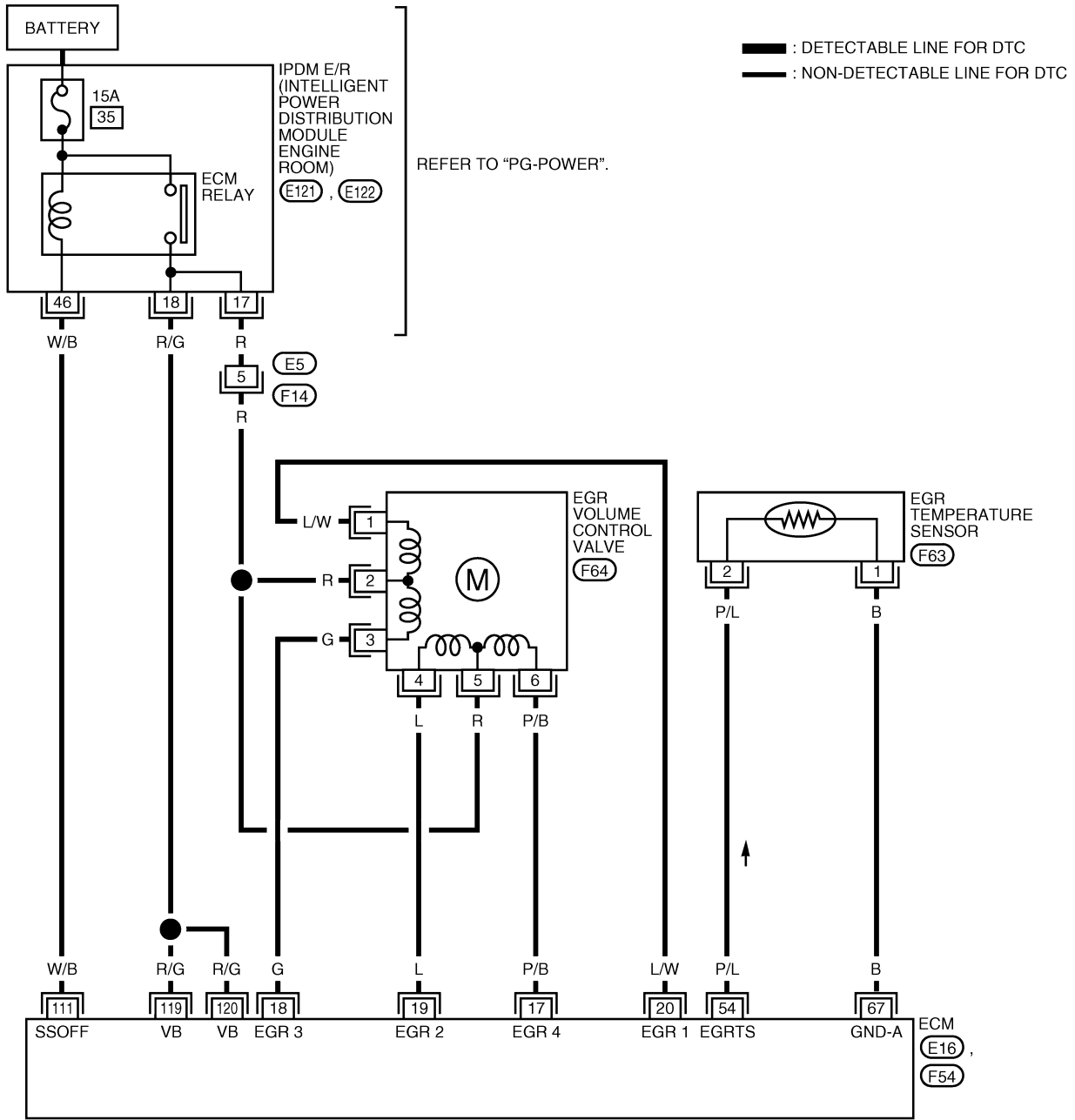

BBWA2547E

DTC P1402 EGR FUNCTION

Specification data are reference values and are measured between each terminal and ground.

CAUTION:

Do not use ECM ground terminals when measuring input/output voltage. Doing so may result in damage to the ECM's transistor. Use a ground other than ECM terminals, such as the ground.

TER-MINAL NO.	WIRE COLOR	ITEM	CONDITION	DATA (DC Voltage)
17 18 19 20	P/B G L L/W	EGR volume control valve	[Engine is running] ● Idle speed	0.1 - 14V
54	P/L	EGR temperature sensor	[Ignition switch: ON]	Less than 4.5V
			[Engine is running] ● Warm-up condition ● EGR system: Operating	0 - 1.5V
67	B	Sensor ground	[Engine is running] ● Warm-up condition ● Idle speed	Approximately 0V
111	W/B	ECM relay (Self shut-off)	[Engine is running] [Ignition switch: OFF] ● For a few seconds after turning ignition switch OFF	0 - 1.5V
			[Ignition switch: OFF] ● More than a few seconds after turning ignition switch OFF	BATTERY VOLTAGE (11 - 14V)
119 120	R/G R/G	Power supply for ECM	[Ignition switch: ON]	BATTERY VOLTAGE (11 - 14V)

★: Average voltage for pulse signal (Actual pulse signal can be confirmed by oscilloscope.)

Diagnostic Procedure

UBS00PCU

1. CHECK EGR VOLUME CONTROL VALVE POWER SUPPLY CIRCUIT

1. Turn ignition switch OFF.
2. Disconnect EGR volume control valve harness connector.
3. Turn ignition switch ON.

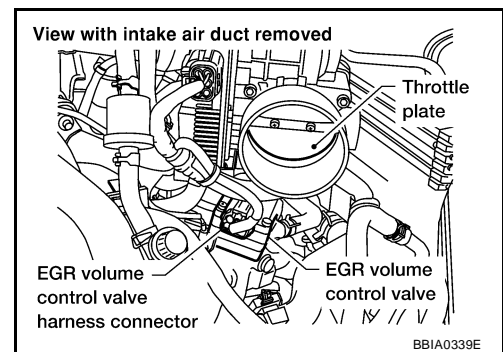

4. Check voltage between EGR volume control valve terminals 2, 5 and ground with CONSULT-II or tester.

Voltage: Battery voltage

OK or NG

- OK >> GO TO 3.
NG >> GO TO 2.

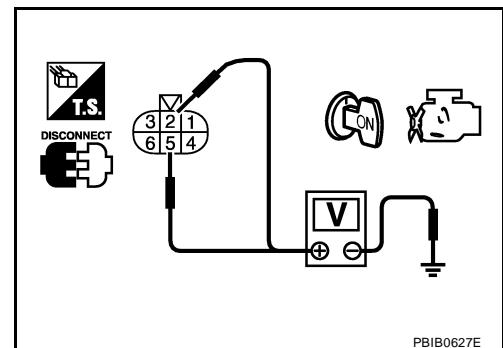

DTC P1402 EGR FUNCTION

2. DETECT MALFUNCTIONING PART

Check the following.

- Harness connectors E5, F14
- Harness for open or short between EGR volume control valve and IPDM E/R
- Harness for open or short between EGR volume control valve and ECM

>> Repair harness or connectors.

3. CHECK EGR VOLUME CONTROL VALVE OUTPUT SIGNAL CIRCUIT FOR OPEN AND SHORT

1. Turn ignition switch OFF.
2. Disconnect ECM harness connector.
3. Check harness continuity between ECM terminals and EGR volume control valve terminals as follows. Refer to Wiring Diagram.

ECM terminal	EGR volume control valve
17	6
18	3
19	4
20	1

Continuity should exist.

4. Also check harness for short to ground and short to power.

OK or NG

OK >> GO TO 4.

NG >> Repair open circuit or short to ground or short to power in harness or connectors.

4. CHECK EGR VOLUME CONTROL VALVE

Refer to [EC-409, "Component Inspection"](#) .

OK or NG

OK >> GO TO 5.

NG >> Replace EGR volume control valve.

5. CHECK EGR TEMPERATURE SENSOR

Refer to [EC-418, "Component Inspection"](#) .

OK or NG

OK >> GO TO 6.

NG >> Replace EGR temperature sensor.

6. CHECK INTERMITTENT INCIDENT

Refer to [EC-149, "TROUBLE DIAGNOSIS FOR INTERMITTENT INCIDENT"](#) .

>> **INSPECTION END**

DTC P1421 COLD START CONTROL

DTC P1421 COLD START CONTROL

PF2:23710

Description

UBS00QAI

ECM controls ignition timing and engine idle speed when engine is started with prewarming up condition. This control promotes the activation of three way catalyst by heating the catalyst and reduces emissions.

On Board Diagnosis Logic

UBS00QAJ

DTC No.	Trouble diagnosis name	DTC detecting condition	Possible cause
P1421 1421	Cold start emission reduction strategy monitoring	ECM does not control ignition timing and engine idle speed properly when engine is started with prewarming up condition.	<ul style="list-style-type: none">● Lack of intake air volume● Fuel injection system● ECM

DTC Confirmation Procedure

UBS00QAK

NOTE:

- If DTC Confirmation Procedure has been previously conducted, always turn ignition switch OFF and wait at least 10 seconds before conducting the next test.
- If DTC P1421 is displayed with other DTC, first perform the trouble diagnosis for other DTC.

TESTING CONDITION:

Before performing the following procedure, confirm that battery voltage is more than 11V at idle.

WITH CONSULT-II

1. Turn ignition switch OFF and wait at least 10 seconds.
2. Turn ignition switch ON.
3. Select "DATA MONITOR" mode with CONSULT-II.
4. Check that the "COOLAN TEMP/S" indication is between 4°C (39°F) and 36°C (97°F).
If "COOLAN TEMP/S" indication is within the specified value, go to the following step.
If "COOLANT TEMP/S" indication is out of the specified value, cool engine down or warm engine up and go to step 1.
5. Start engine and let it idle for 5 minutes.
6. If 1st trip DTC is detected, go to [EC-566, "Diagnostic Procedure"](#)

DATA MONITOR	
MONITOR	NO DTC
ENG SPEED	XXX rpm
COOLAN TEMP/S	XXX °C

SEF174Y

WITH GST

Follow the procedure "WITH CONSULT-II" above.

Diagnostic Procedure

UBS00QAL

1. PERFORM IDLE AIR VOLUME LEARNING

Perform [EC-80, "Idle Air Volume Learning"](#) .

Is Idle Air Volume Learning carried out successfully?

Yes or No

- Yes >> GO TO 2.
No >> Follow the instruction of Idle Air Volume Learning.

2. CHECK INTAKE SYSTEM

Check for the cause of intake air volume lacking. Refer to the following.

- Crushed intake air passage
- Intake air passage clogging

OK or NG

- OK >> GO TO 3.
NG >> Repair or replace malfunctioning part

DTC P1421 COLD START CONTROL

3. CHECK FUEL INJECTION SYSTEM FUNCTION

Perform [EC-322, "DTC Confirmation Procedure"](#) in DTC P0171, P0174 FUEL INJECTION SYSTEM FUNCTION.

OK or NG

- OK >> GO TO 4.
- NG >> Go to [EC-328, "Diagnostic Procedure"](#) .

4. PERFORM DTC CONFIRMATION PROCEDURE

With CONSULT-II

1. Turn ignition switch ON.
2. Select "SELF DIAG RESULTS" mode with CONSULT-II.
3. Touch "ERASE".
4. **Perform DTC Confirmation Procedure.**
See [EC-566, "DTC Confirmation Procedure"](#) .
5. Is the 1st trip DTC P1421 displayed again?

With GST

1. Turn ignition switch ON.
2. Select Service \$04 with GST.
3. **Perform DTC Confirmation Procedure.**
See [EC-566, "DTC Confirmation Procedure"](#) .
4. Is the 1st trip DTC P1421 displayed again?

Yes or No

- Yes >> GO TO 5.
- No >> **INSPECTION END**

5. REPLACE ECM

1. Replace ECM.
2. Perform initialization of NVIS (NATS) system and registration of all NVIS (NATS) ignition key IDs.
Refer to [BL-205, "ECM Re-communicating Function"](#) .
3. Perform [EC-79, "VIN Registration"](#) .
4. Perform [EC-80, "Accelerator Pedal Released Position Learning"](#) .
5. Perform [EC-80, "Throttle Valve Closed Position Learning"](#) .
6. Perform [EC-80, "Idle Air Volume Learning"](#) .

>> **INSPECTION END**

DTC P1564 ASCD STEERING SWITCH

PFP:25551

DTC P1564 ASCD STEERING SWITCH

Component Description

UBS00PCV

ASCD steering switch has variant values of electrical resistance for each button. ECM reads voltage variation of switch, and determines which button is operated.

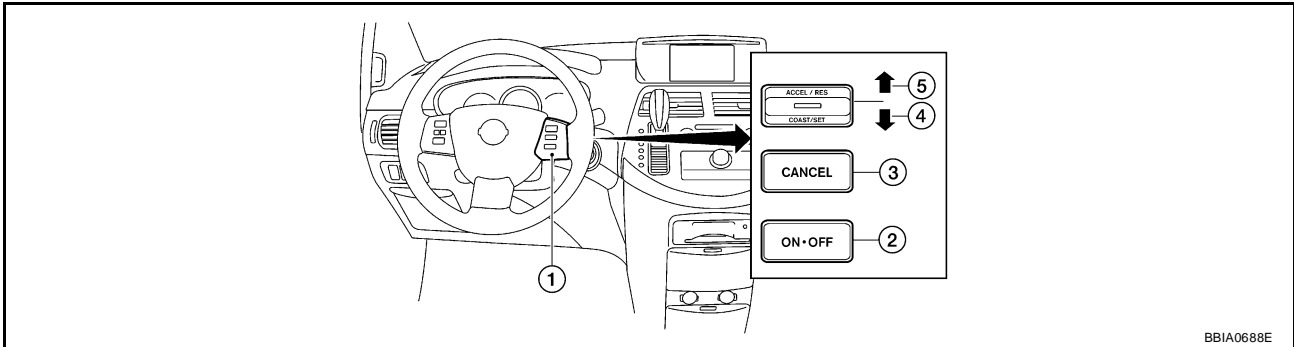

BBIA0688E

1. ASCD steering switch
2. MAIN switch
3. CANCEL switch
4. SET/COAST switch
5. RESUME/ACCELERATE switch

Refer to [EC-29, "AUTOMATIC SPEED CONTROL DEVICE \(ASCD\)"](#) for the ASCD function.

CONSULT-II Reference Value in Data Monitor Mode

UBS00PCW

Specification data are reference values.

MONITOR ITEM	CONDITION		SPECIFICATION
MAIN SW	● Ignition switch: ON	MAIN switch: Pressed	ON
		MAIN switch: Released	OFF
CANCEL SW	● Ignition switch: ON	CANCEL switch: Pressed	ON
		CANCEL switch: Released	OFF
RESUME/ACC SW	● Ignition switch: ON	RESUME/ACCELERATE switch: Pressed	ON
		RESUME/ACCELERATE switch: Released	OFF
SET SW	● Ignition switch: ON	SET/COAST switch: Pressed	ON
		SET/COAST switch: Released	OFF

On Board Diagnosis Logic

UBS00PCX

This self-diagnosis has the one trip detection logic.

The MIL will not light up for this diagnosis.

NOTE:

If DTC P1564 is displayed with DTC P0605, first perform the trouble diagnosis for DTC P0605. Refer to [EC-526, "DTC P0605 ECM"](#).

DTC No.	Trouble Diagnosis Name	DTC Detecting Condition	Possible Cause
P1564 1564	ASCD steering switch	<ul style="list-style-type: none"> ● An excessively high voltage signal from the ASCD steering switch is sent to ECM. ● ECM detects that input signal from the ASCD steering switch is out of the specified range. ● ECM detects that the ASCD steering switch is stuck ON. 	<ul style="list-style-type: none"> ● Harness or connectors (The switch circuit is open or shorted.) ● ASCD steering switch ● ECM

DTC P1564 ASCD STEERING SWITCH

UBS00PCY

DTC Confirmation Procedure

NOTE:

If DTC Confirmation Procedure has been previously conducted, always turn ignition switch OFF and wait at least 10 seconds before conducting the next test.

④ WITH CONSULT-II

1. Turn ignition switch ON.
2. Select "DATA MONITOR" mode with CONSULT-II.
3. Wait at least 10 seconds.
4. Press MAIN switch for at least 10 seconds, then release it and wait at least 10 seconds.
5. Press CANCEL switch for at least 10 seconds, then release it and wait at least 10 seconds.
6. Press RESUME/ACCELERATE switch for at least 10 seconds, then release it and wait at least 10 seconds.
7. Press SET/COAST switch for at least 10 seconds, then release it and wait at least 10 seconds.
8. If DTC is detected, go to [EC-572, "Diagnostic Procedure"](#) .

DATA MONITOR	
MONITOR	NO DTC
ENG SPEED	XXX rpm

SEF058Y

④ WITH GST

Follow the procedure "WITH CONSULT-II" above.

DTC P1564 ASCD STEERING SWITCH

UBS00PCZ

Wiring Diagram

EC-ASC/SW-01

— : DETECTABLE LINE FOR DTC
 — : NON-DETECTABLE LINE FOR DTC

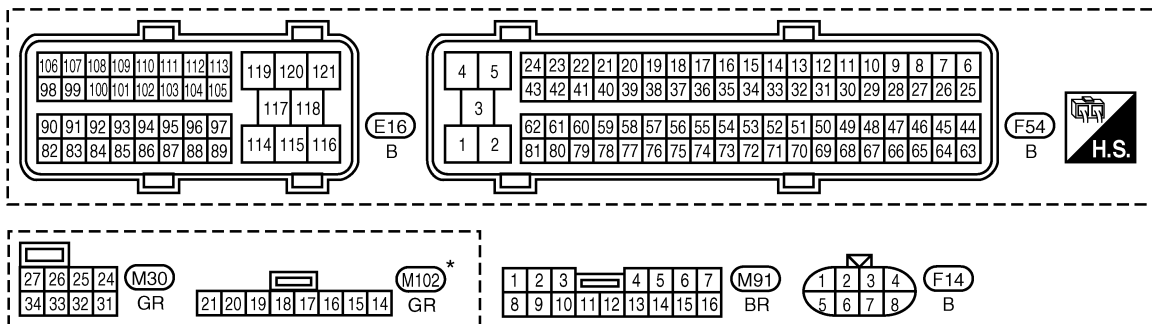
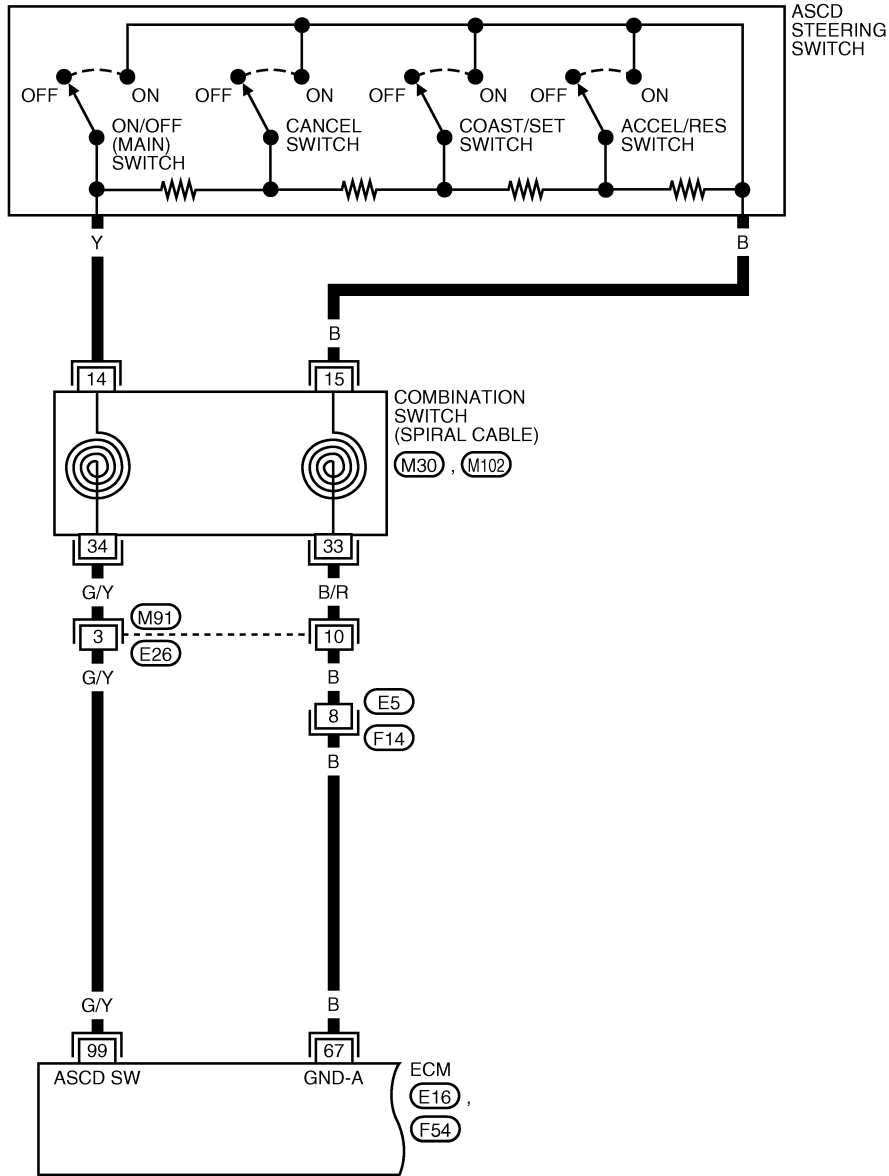

* : THIS CONNECTOR IS NOT SHOWN IN "HARNESS LAYOUT" OF PG SECTION.

BBWA2530E

DTC P1564 ASCD STEERING SWITCH

Specification data are reference values and are measured between each terminal and ground.

CAUTION:

Do not use ECM ground terminals when measuring input/output voltage. Doing so may result in damage to the ECM's transistor. Use a ground other than ECM terminals, such as the ground.

TER-MINAL NO.	WIRE COLOR	ITEM	CONDITION	DATA (DC Voltage)
67	B	Sensor ground	[Engine is running] <ul style="list-style-type: none"> ● Warm-up condition ● Idle speed 	Approximately 0V
99	G/Y	ASCD steering switch	[Ignition switch: ON] <ul style="list-style-type: none"> ● ASCD steering switch: OFF 	Approximately 4V
			[Ignition switch: ON] <ul style="list-style-type: none"> ● MAIN switch: Pressed 	Approximately 0V
			[Ignition switch: ON] <ul style="list-style-type: none"> ● CANCEL switch: Pressed 	Approximately 1V
			[Ignition switch: ON] <ul style="list-style-type: none"> ● RESUME/ACCELERATE switch: Pressed 	Approximately 3V
			[Ignition switch: ON] <ul style="list-style-type: none"> ● SET/COAST switch: Pressed 	Approximately 2V

A
EC
C
D
E
F
G
H
I
J
K
L
M

DTC P1564 ASCD STEERING SWITCH

UBS00PDO

Diagnostic Procedure

1. CHECK GROUND CONNECTIONS

1. Turn ignition switch OFF.
2. Loosen and retighten three ground screws on the body. Refer to [EC-158, "Ground Inspection"](#).

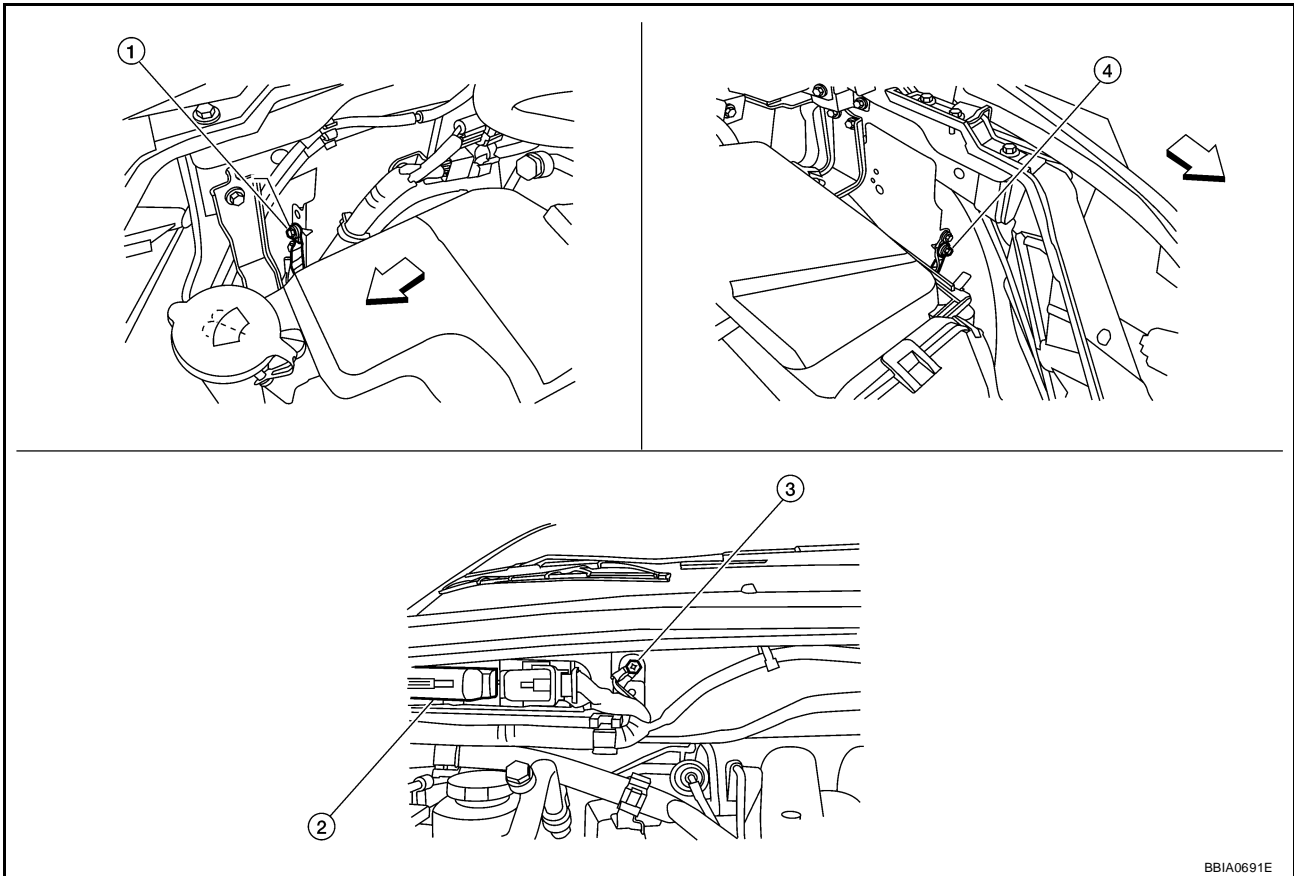

BBA0691E

← Vehicle front

1. Body ground E24

2. ECM

3. Body ground E9

4. Body ground E15

OK or NG

OK >> GO TO 2.

NG >> Repair or replace ground connections.

DTC P1564 ASCD STEERING SWITCH

2. CHECK ASCD STEERING SWITCH CIRCUIT

With CONSULT-II

- Turn ignition switch ON.
- Select "MAIN SW", "CANCEL SW", "RESUME/ACC SW" and "SET/COAST SW" in "DATA MONITOR" mode with CONSULT-II.
- Check each item indication under the following conditions.

Switch	Monitor item	Condition	Indication
MAIN switch	MAIN SW	Pressed	ON
		Released	OFF
CANCEL switch	CANCEL SW	Pressed	ON
		Released	OFF
RESUME/ACCELERATE switch	RESUME/ACC SW	Pressed	ON
		Released	OFF
SET/COAST switch	SET SW	Pressed	ON
		Released	OFF

DATA MONITOR	
MONITOR	NO DTC
MAIN SW	OFF
CANCEL SW	OFF
RESUME/ACC SW	OFF
SET SW	OFF

SEC006D

Without CONSULT-II

- Turn ignition switch ON.
- Check voltage between ECM terminal 99 and ground with pressing each button.

Switch	Condition	Voltage [V]
MAIN switch	Pressed	Approx. 0
	Released	Approx. 4
CANCEL switch	Pressed	Approx. 1
	Released	Approx. 4
RESUME/ACCELERATE switch	Pressed	Approx. 3
	Released	Approx. 4
SET/COAST switch	Pressed	Approx. 2
	Released	Approx. 4

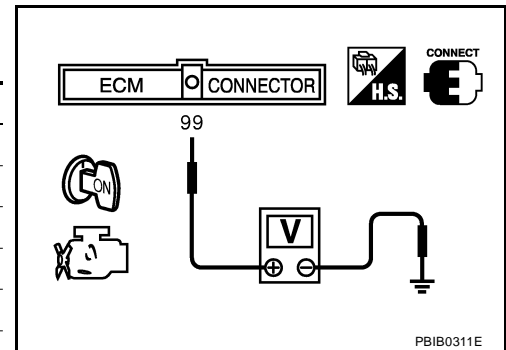

OK or NG

- OK >> GO TO 8.
- NG >> GO TO 3.

3. CHECK ASCD STEERING SWITCH GROUND CIRCUIT FOR OPEN AND SHORT

- Turn ignition switch OFF.
- Disconnect combination switch harness connector M102.
- Disconnect ECM harness connector.
- Check harness continuity between combination switch terminal 15 and ECM terminal 67. Refer to Wiring Diagram.

Continuity should exist.

- Also check harness for short to ground and short to power.

OK or NG

- OK >> GO TO 5.
- NG >> GO TO 4.

DTC P1564 ASCD STEERING SWITCH

4. DETECT MALFUNCTIONING PART

Check the following.

- Harness connectors E5, F14
- Harness connectors E26, M91
- Combination switch (spiral cable)
- Harness for open and short between ECM and combination switch

>> Repair open circuit or short to ground or short to power in harness or connectors.

5. CHECK ASCD STEERING SWITCH INPUT SIGNAL CIRCUIT FOR OPEN AND SHORT

1. Check harness continuity between ECM terminal 99 and combination switch terminal 14.
Refer to Wiring Diagram.

Continuity should exist.

2. Also check harness for short to ground and short to power.

OK or NG

- OK >> GO TO 7.
- NG >> GO TO 6.

6. DETECT MALFUNCTIONING PART

Check the following.

- Harness connectors E26, M91
- Combination switch (spiral cable)
- Harness for open and short between ECM and combination switch

>> Repair open circuit or short to ground or short to power in harness or connectors.

7. CHECK ASCD STEERING SWITCH

Refer to [EC-575, "Component Inspection"](#) .

OK or NG

- OK >> GO TO 8.
- NG >> Replace ASCD steering switch.

8. CHECK INTERMITTENT INCIDENT

Refer to [EC-149, "TROUBLE DIAGNOSIS FOR INTERMITTENT INCIDENT"](#) .

>> **INSPECTION END**

DTC P1564 ASCD STEERING SWITCH

UBS00PD1

Component Inspection ASCD STEERING SWITCH

1. Disconnect combination switch (spiral cable).
2. Check continuity between combination switch (spiral cable) terminals 14 and 15 with pushing each switch.

Switch	Condition	Resistance [Ω]
MAIN switch	Pressed	Approx. 0
	Released	Approx. 4,000
CANCEL switch	Pressed	Approx. 250
	Released	Approx. 4,000
RESUME/ACCELERATE switch	Pressed	Approx. 1,480
	Released	Approx. 4,000
SET/COAST switch	Pressed	Approx. 660
	Released	Approx. 4,000

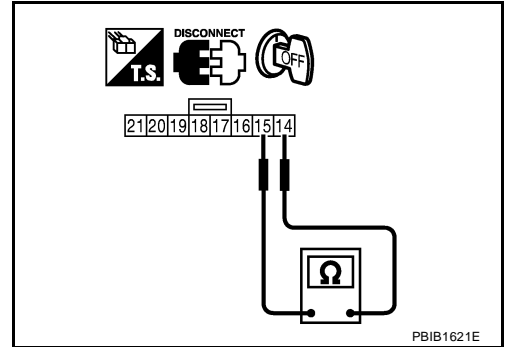

A
EC
C
D
E
F
G
H
I
J
K
L
M

DTC P1572 ASCD BRAKE SWITCH

DTC P1572 ASCD BRAKE SWITCH

PFP:25320

Component Description

UBS00PD2

When the brake pedal is depressed, ASCD brake switch is turned OFF and stop lamp switch is turned ON. ECM detects the state of the brake pedal by this input of two kinds (ON/OFF signal).

Refer to [EC-29, "AUTOMATIC SPEED CONTROL DEVICE \(ASCD\)"](#) for the ASCD function.

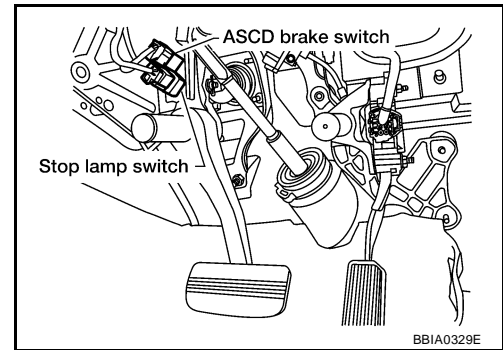

CONSULT-II Reference Value in Data Monitor Mode

UBS00PD3

Specification data are reference values.

MONITOR ITEM	CONDITION	SPECIFICATION
BRAKE SW1 (ASCD brake switch)	● Ignition switch: ON Brake pedal: Fully released	ON
	Brake pedal: Slightly depressed	OFF
BRAKE SW2 (Stop lamp switch)	● Ignition switch: ON Brake pedal: Fully released	OFF
	Brake pedal: Slightly depressed	ON

On Board Diagnosis Logic

UBS00PD4

This self-diagnosis has the one trip detection logic.

The MIL will not light up for this diagnosis.

NOTE:

- If DTC P1572 is displayed with DTC P0605, first perform the trouble diagnosis for DTC P0605. Refer to [EC-526, "DTC P0605 ECM"](#).
- This self-diagnosis has the one trip detection logic. When malfunction A is detected, DTC is not stored in ECM memory. And in that case, 1st trip DTC and 1st trip freeze frame data are displayed. 1st trip DTC is erased when ignition switch OFF. And even when malfunction A is detected in two consecutive trips, DTC is not stored in ECM memory.

DTC No.	Trouble Diagnosis Name	DTC Detecting Condition	Possible Cause
P1572 1572	ASCD brake switch	A) When the vehicle speed is above 30 km/h (19 MPH), ON signals from the stop lamp switch and the ASCD brake switch are sent to the ECM at the same time.	<ul style="list-style-type: none"> ● Harness or connectors (The stop lamp switch circuit is shorted.) ● Harness or connectors (The ASCD brake switch circuit is shorted.)
		B) ASCD brake switch signal is not sent to ECM for extremely long time while the vehicle is driving	<ul style="list-style-type: none"> ● Stop lamp switch ● ASCD brake switch ● Incorrect stop lamp switch installation ● Incorrect ASCD brake switch installation ● ECM

DTC P1572 ASCD BRAKE SWITCH

UBS00PD5

DTC Confirmation Procedure

CAUTION:

Always drive vehicle at a safe speed.

NOTE:

- If DTC Confirmation Procedure has been previously conducted, always turn ignition switch OFF and wait at least 10 seconds before conducting the next test.
- Procedure for malfunction B is not described here. It takes extremely long time to complete procedure for malfunction B. By performing procedure for malfunction A, the incident that causes malfunction B can be detected.

WITH CONSULT-II

TESTING CONDITION:

Steps 4 and 5 may be conducted with the drive wheels lifted in the shop or by driving the vehicle. If a road test is expected to be easier, it is unnecessary to lift the vehicle.

1. Start engine (TCS switch or VDC switch OFF).
2. Select "DATA MONITOR" mode with CONSULT-II.
3. Press MAIN switch and make sure that CRUISE indicator lights up.
4. Drive the vehicle for at least 5 consecutive seconds under the following condition.

VHCL SPEED SE	More than 30 km/h (19 MPH)
Shift lever	Suitable position

If 1st trip DTC is detected, go to [EC-579, "Diagnostic Procedure"](#)

If 1st trip DTC is not detected, go to the following step.

5. Drive the vehicle for at least 5 consecutive seconds under the following condition.

VHCL SPEED SE	More than 30 km/h (19 MPH)
Shift lever	Suitable position
Driving location	Depress the brake pedal for more than 5 seconds so as not to come off from the above-mentioned vehicle speed.

6. If 1st trip DTC is detected, go to [EC-579, "Diagnostic Procedure"](#).

WITH GST

Follow the procedure "WITH CONSULT-II" above.

DATA MONITOR	
MONITOR	NO DTC
ENG SPEED	XXX rpm
VHCL SPEED SE	XXX km/h
CRUISE LAMP	ON
BRAKE SW 1	ON
BRAKE SW 2	OFF

PBIB2386E

DTC P1572 ASCD BRAKE SWITCH

UBS00PD6

Wiring Diagram

EC-ASC/BS-01

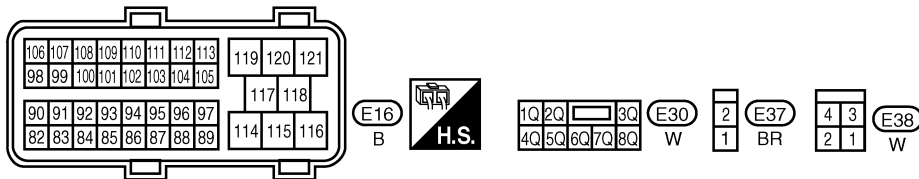
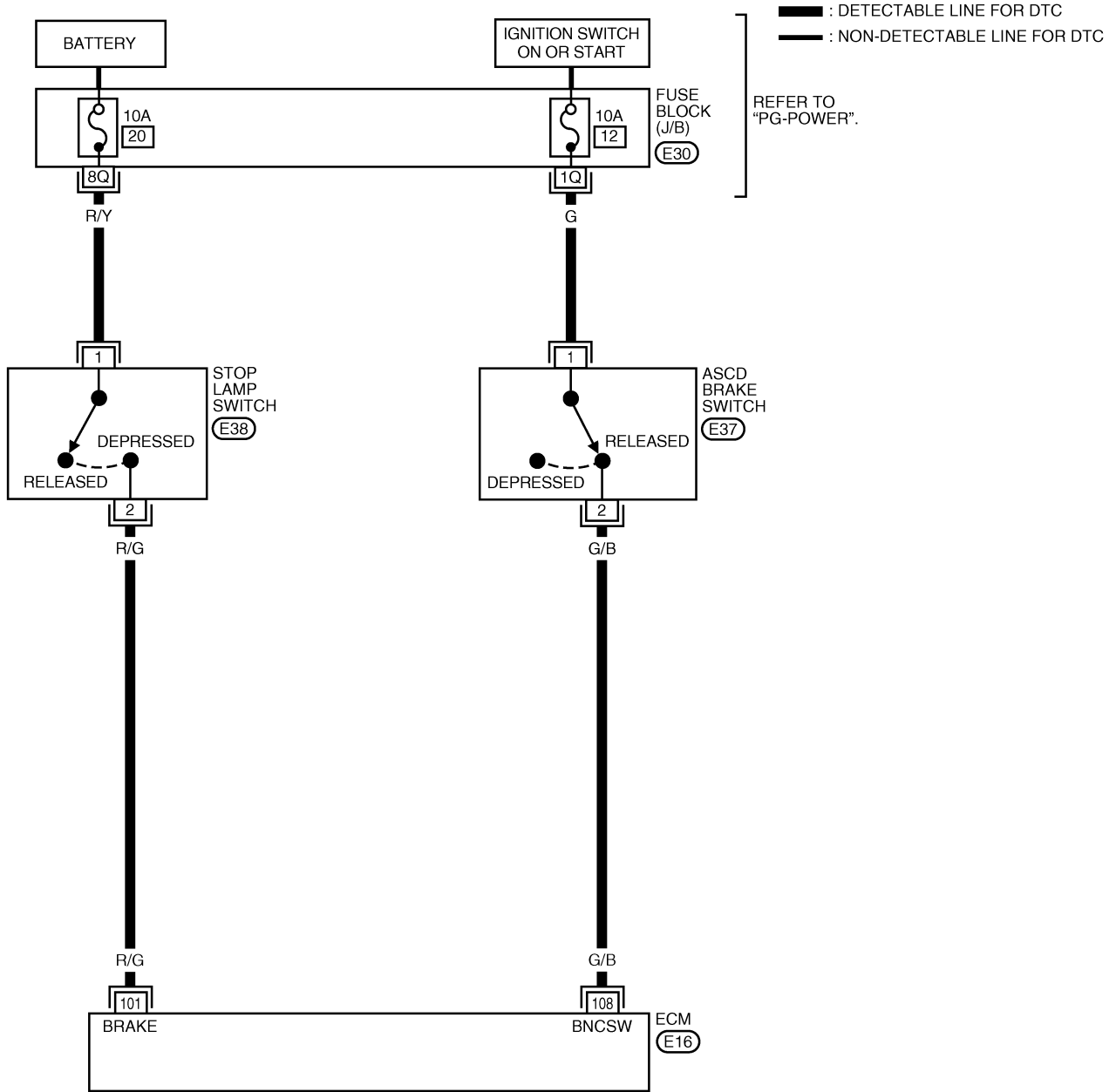

BBWA2531E

DTC P1572 ASCD BRAKE SWITCH

Specification data are reference values and are measured between each terminal and ground.

CAUTION:

Do not use ECM ground terminals when measuring input/output voltage. Doing so may result in damage to the ECM's transistor. Use a ground other than ECM terminals, such as the ground.

TER-MINAL NO.	WIRE COLOR	ITEM	CONDITION	DATA (DC Voltage)
101	R/G	Stop lamp switch	[Ignition switch: OFF] ● Brake pedal: Fully released	Approximately 0V
			[Ignition switch: OFF] ● Brake pedal: Slightly depressed	BATTERY VOLTAGE (11 - 14V)
108	G/B	ASCD brake switch	[Ignition switch: ON] ● Brake pedal: Fully released	BATTERY VOLTAGE (11 - 14V)
			[Ignition switch: ON] ● Brake pedal: Slightly depressed	Approximately 0V

Diagnostic Procedure

UBS00PD7

1. CHECK OVERALL FUNCTION-I

With CONSULT-II

- Turn ignition switch ON.
- Select "BRAKE SW1" in "DATA MONITOR" mode with CONSULT-II.
- Check "BRAKE SW1" indication under the following conditions.

CONDITION	INDICATION
Brake pedal: Slightly depressed	OFF
Brake pedal: Fully released	ON

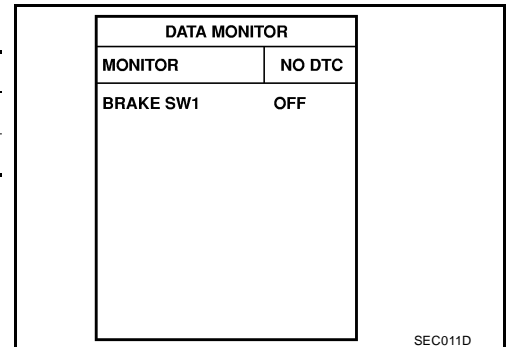

Without CONSULT-II

- Turn ignition switch ON.
- Check voltage between ECM terminal 108 and ground under the following conditions.

CONDITION	VOLTAGE
Brake pedal: Slightly depressed	Approximately 0V
Brake pedal: Fully released	Battery voltage

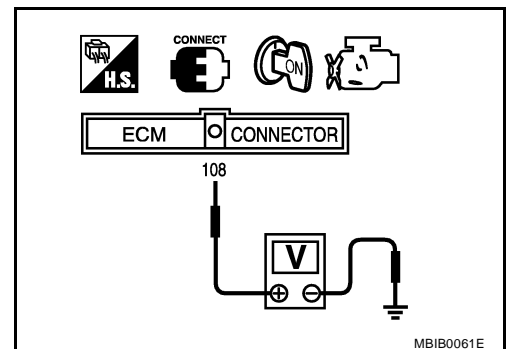

OK or NG

- OK >> GO TO 2.
- NG >> GO TO 3.

DTC P1572 ASCD BRAKE SWITCH

2. CHECK OVERALL FUNCTION-II

With CONSULT-II

Check "BRAKE SW2" indication in "DATA MONITOR" mode.

CONDITION	INDICATION
Brake pedal: Fully released	OFF
Brake pedal: Slightly depressed	ON

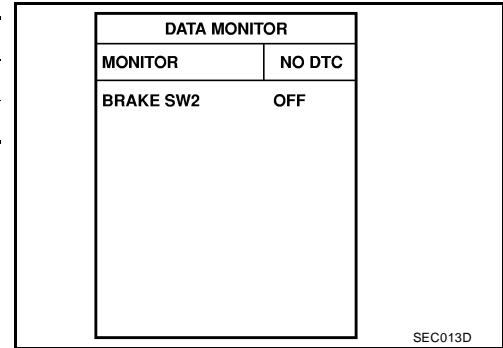

Without CONSULT-II

Check voltage between ECM terminal 101 and ground under the following conditions.

CONDITION	VOLTAGE
Brake pedal: Fully released	Approximately 0V
Brake pedal: Slightly depressed	Battery voltage

OK or NG

- OK >> GO TO 11.
- NG >> GO TO 7.

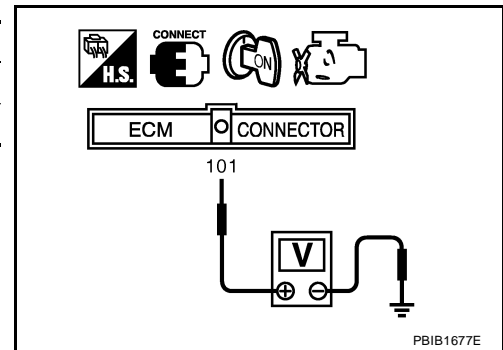

3. CHECK ASCD BRAKE SWITCH POWER SUPPLY CIRCUIT

1. Turn ignition switch OFF.
2. Disconnect ASCD brake switch harness connector.
3. Turn ignition switch ON.

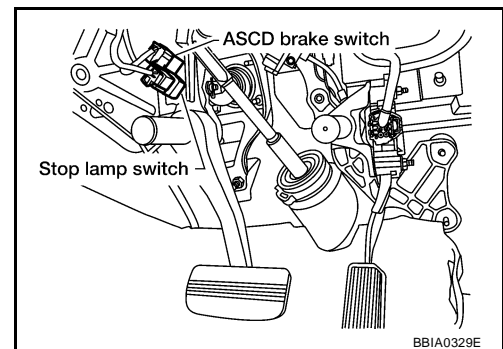

4. Check voltage between ASCD brake switch terminal 1 and ground with CONSULT-II or tester.

Voltage: Battery voltage

OK or NG

- OK >> GO TO 5.
- NG >> GO TO 4.

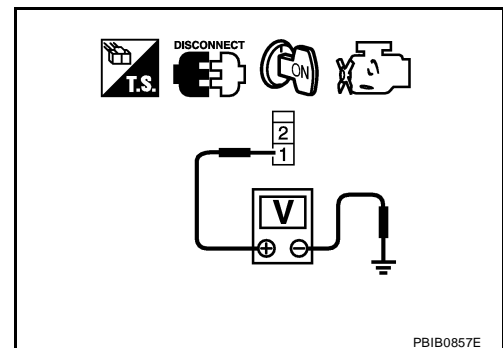

DTC P1572 ASCD BRAKE SWITCH

4. DETECT MALFUNCTIONING PART

Check the following.

- Fuse block (J/B) connector E30
- 10A fuse
- Harness for open or short between ASCD brake switch and fuse

>> Repair open circuit or short to ground or short to power in harness or connectors.

5. CHECK ASCD BRAKE SWITCH INPUT SIGNAL CIRCUIT FOR OPEN AND SHORT

1. Turn ignition switch OFF.
2. Disconnect ECM harness connector.
3. Check harness continuity between ECM terminal 108 and ASCD brake switch terminal 2. Refer to Wiring Diagram.

Continuity should exist.

4. Also check harness for short to ground and short to power.

OK or NG

OK >> GO TO 6.

NG >> Repair open circuit or short to ground or short to power in harness or connectors.

6. CHECK ASCD BRAKE SWITCH

Refer to [EC-582, "Component Inspection"](#)

OK or NG

OK >> GO TO 11.

NG >> Replace ASCD brake switch.

7. CHECK STOP LAMP SWITCH POWER SUPPLY CIRCUIT

1. Turn ignition switch OFF.
2. Disconnect stop lamp switch harness connector.

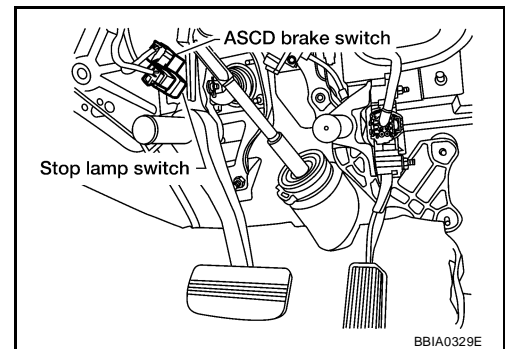

3. Check voltage between stop lamp switch terminal 1 and ground with CONSULT -II or tester.

Voltage: Battery voltage

OK or NG

OK >> GO TO 9.

NG >> GO TO 8.

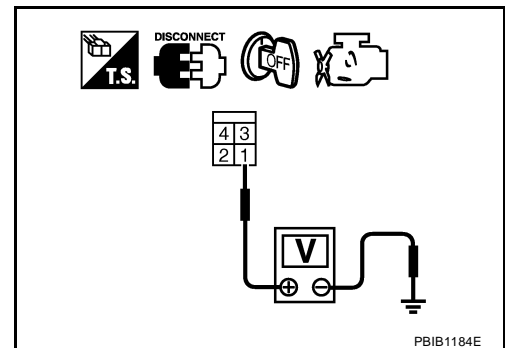

DTC P1572 ASCD BRAKE SWITCH

8. DETECT MALFUNCTIONING PART

Check the following.

- Fuse block (J/B) connector E30
- 10A fuse
- Harness for open or short between stop lamp switch and battery

>> Repair open circuit or short to ground or short to power in harness or connectors.

9. CHECK STOP LAMP SWITCH INPUT SIGNAL CIRCUIT FOR OPEN AND SHORT

1. Disconnect ECM harness connector.
2. Check harness continuity between ECM terminal 101 and stop lamp switch terminal 2. Refer to Wiring Diagram.

Continuity should exist.

3. Also check harness for short to ground and short to power.

OK or NG

OK >> GO TO 10.

NG >> Repair open circuit or short to ground or short to power in harness or connectors.

10. CHECK STOP LAMP SWITCH

Refer to [EC-582, "Component Inspection"](#)

OK or NG

OK >> GO TO 11.

NG >> Replace stop lamp switch.

11. CHECK INTERMITTENT INCIDENT

Refer to [EC-149, "TROUBLE DIAGNOSIS FOR INTERMITTENT INCIDENT"](#) .

>> **INSPECTION END**

Component Inspection ASC D BRAKE SWITCH

UBS00PD8

1. Turn ignition switch OFF.
2. Disconnect ASCD brake switch harness connector.
3. Check harness continuity between ASCD brake switch terminals 1 and 2 under the following conditions.

Condition	Continuity
Brake pedal: Fully released	Should exist
Brake pedal: Slightly depressed	Should not exist

If NG, adjust ASCD brake switch installation, refer to [BR-6, "BRAKE PEDAL"](#) , and perform step 3 again.

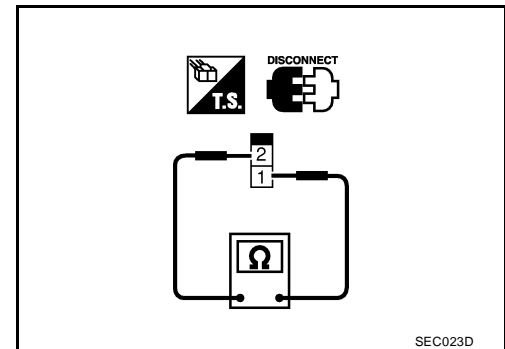

DTC P1572 ASCD BRAKE SWITCH

STOP LAMP SWITCH

1. Turn ignition switch OFF.
2. Disconnect stop lamp switch harness connector.
3. Check harness continuity between stop lamp switch terminals 1 and 2 under the following conditions.

Condition	Continuity
Brake pedal: Fully released	Should not exist
Brake pedal: Slightly depressed	Should exist

If NG, adjust stop lamp switch installation, refer to [BR-6](#), "[BRAKE PEDAL](#)", and perform step 3 again.

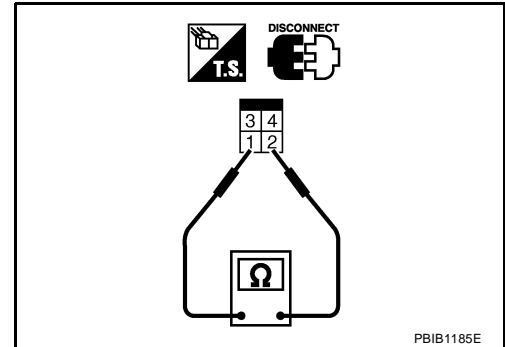

A

EC

C

D

E

F

G

H

I

J

K

L

M

DTC P1574 ASCD VEHICLE SPEED SENSOR

DTC P1574 ASCD VEHICLE SPEED SENSOR

PF3:31036

Component Description

UBS00PD9

The ECM receives two vehicle speed sensor signals via CAN communication line. One is sent from combination meter and the other is from TCM (Transmission control module). The ECM uses these signals for ASCD control. Refer to [EC-29, "AUTOMATIC SPEED CONTROL DEVICE \(ASCD\)"](#) for ASCD functions.

On Board Diagnosis Logic

UBS00PDA

This self-diagnosis has the one trip detection logic.
The MIL will not light up for this diagnosis.

NOTE:

- If DTC P1574 is displayed with DTC U1000 or U1001, first perform the trouble diagnosis for DTC U1000, U1001. Refer to [EC-159, "DTC U1000, U1001 CAN COMMUNICATION LINE"](#).
- If DTC P1574 is displayed with DTC U1010, first perform the trouble diagnosis for DTC U1010. Refer to [EC-162, "DTC U1010 CAN COMMUNICATION"](#).
- If DTC P1574 is displayed with DTC P0500, first perform the trouble diagnosis for DTC P0500. Refer to [EC-510, "DTC P0500 VSS"](#).
- If DTC P1574 is displayed with DTC P0605, first perform the trouble diagnosis for DTC P0605. Refer to [EC-526, "DTC P0605 ECM"](#).

DTC No.	Trouble Diagnosis Name	DTC Detecting Condition	Possible Cause
P1574 1574	ASCD vehicle speed sensor	ECM detects a difference between two vehicle speed signals is out of the specified range.	<ul style="list-style-type: none"> ● Harness or connectors (The CAN communication line is open or shorted.) ● ABS actuator and electric unit (control unit) ● Wheel sensor ● TCM ● ECM

DTC Confirmation Procedure

UBS00PDB

CAUTION:

Always drive vehicle at a safe speed.

NOTE:

If DTC Confirmation Procedure has been previously conducted, always turn ignition switch OFF and wait at least 10 seconds before conducting the next test.

TESTING CONDITION:

Step 3 may be conducted with the drive wheels lifted in the shop or by driving the vehicle. If a road test is expected to be easier, it is unnecessary to lift the vehicle.

WITH CONSULT-II

1. Start engine (TCS switch or VDC switch OFF).
2. Select "DATA MONITOR" mode with CONSULT-II.
3. Drive the vehicle at more than 40 km/h (25 MPH).
4. If DTC is detected, go to [EC-585, "Diagnostic Procedure"](#).

DATA MONITOR	
MONITOR	NO DTC
ENG SPEED	XXX rpm

SEF058Y

WITH GST

Follow the procedure "WITH CONSULT-II" above.

DTC P1574 ASCD VEHICLE SPEED SENSOR

Diagnostic Procedure

UBS00PDC

1. CHECK DTC WITH TCM

Check DTC with TCM. Refer to [AT-40, "OBD-II Diagnostic Trouble Code \(DTC\)"](#) .

OK or NG

OK >> GO TO 2.

NG >> Perform trouble shooting relevant to DTC indicated.

2. CHECK DTC WITH "ABS ACTUATOR AND ELECTRIC UNIT (CONTROL UNIT)"

Refer to [BRC-10, "TROUBLE DIAGNOSIS"](#) or [BRC-55, "TROUBLE DIAGNOSIS"](#) .

OK or NG

OK >> **INSPECTION END**

NG >> Repair or replace.

A

EC

C

D

E

F

G

H

I

J

K

L

M

DTC P1800 VIAS CONTROL SOLENOID VALVE

PFP:14955

DTC P1800 VIAS CONTROL SOLENOID VALVE

Component Description

UBS00PDD

The VIAS control solenoid valve (2) cuts the intake manifold vacuum signal for power valve control. It responds to ON/OFF signals from the ECM. When the solenoid is off, the vacuum signal from the intake manifold is cut. When the ECM sends an ON signal the coil pulls the plunger downward and feeds the vacuum signal to the power valve actuator (1).

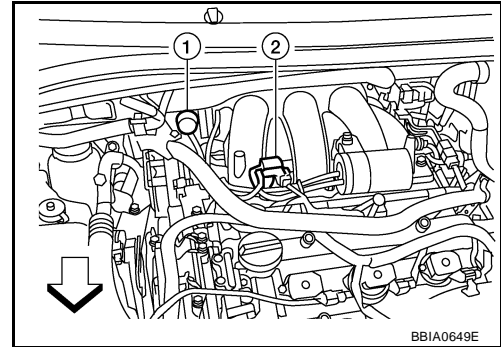

- ↵: Vehicle front

CONSULT-II Reference Value in Data Monitor Mode

UBS00PDE

Specification data are reference values.

MONITOR ITEM	CONDITION	SPECIFICATION
VIAS S/V	• Engine: After warming up	1,800 - 3,600 rpm
		Except above conditions
		ON
		OFF

On Board Diagnosis Logic

UBS00PDF

The MIL will not light up for this self-diagnosis.

DTC No.	Trouble diagnosis name	DTC detecting condition	Possible cause
P1800 1800	VIAS control solenoid valve circuit	An excessively low or high voltage signal is sent to ECM through the valve	<ul style="list-style-type: none"> • Harness or connectors (The solenoid valve circuit is open or shorted.) • VIAS control solenoid valve

DTC Confirmation Procedure

UBS00PDG

NOTE:

If DTC Confirmation Procedure has been previously conducted, always turn ignition switch OFF and wait at least 10 seconds before conducting the next test.

TESTING CONDITION:

Before performing the following procedure, confirm that battery voltage is between 11V at idle.

④ WITH CONSULT-II

1. Turn ignition switch ON.
2. Select "DATA MONITOR" mode with CONSULT-II.
3. Start engine and let it idle for at least 5 seconds.
4. If 1st trip DTC is detected, go to [EC-588, "Diagnostic Procedure"](#)

DATA MONITOR	
MONITOR	NO DTC
ENG SPEED	XXX rpm

SEF058Y

④ WITH GST

Follow the procedure "WITH CONSULT-II" above.

DTC P1800 VIAS CONTROL SOLENOID VALVE

Wiring Diagram

UBS00PDH

EC-VIAS/V-01

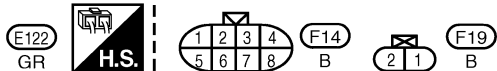
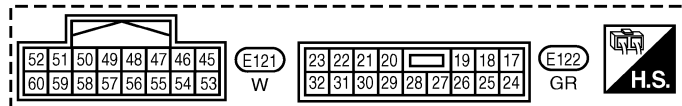
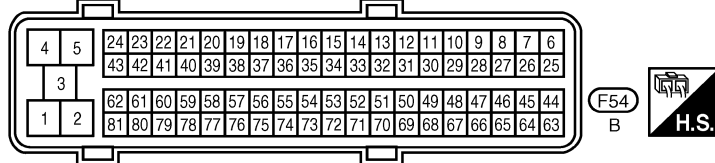
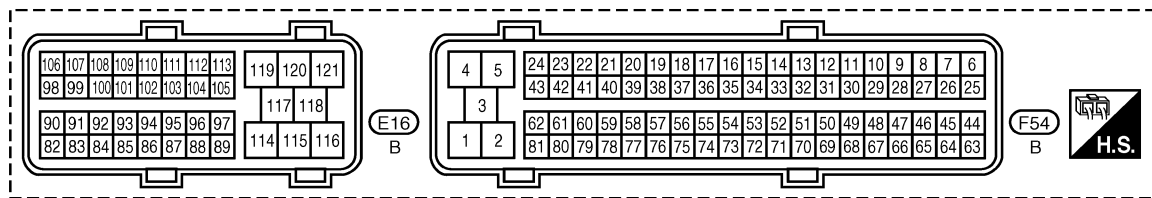
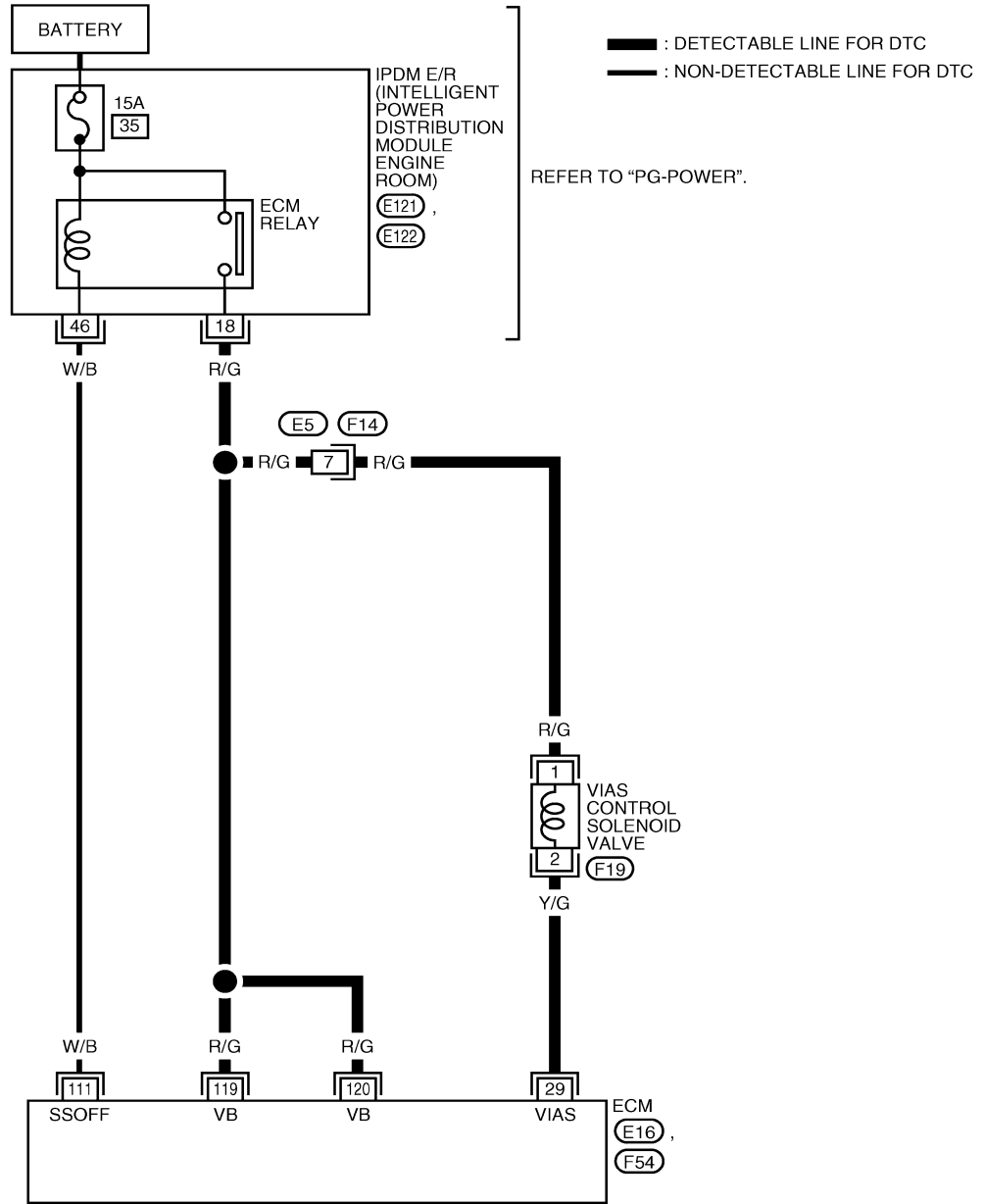

BBWA2533E

DTC P1800 VIAS CONTROL SOLENOID VALVE

Specification data are reference values and are measured between each terminal and ground.

CAUTION:

Do not use ECM ground terminals when measuring input/output voltage. Doing so may result in damage to the ECM's transistor. Use a ground other than ECM terminals, such as the ground.

TER-MINAL NO.	WIRE COLOR	ITEM	CONDITION	DATA (DC Voltage)
29	Y/G	VIAS control solenoid valve	[Engine is running] ● Idle speed	BATTERY VOLTAGE (11 - 14V)
			[Engine is running] ● Engine speed: Between 1,800 and 3,600 rpm.	0 - 1.0V
111	W/B	ECM relay (Self shut-off)	[Engine is running] [Ignition switch: OFF] ● For a few seconds after turning ignition switch OFF	0 - 1.5V
			[Ignition switch: OFF] ● More than a few seconds after turning ignition switch OFF	BATTERY VOLTAGE (11 - 14V)
119 120	R/G R/G	Power supply for ECM	[Ignition switch: ON]	BATTERY VOLTAGE (11 - 14V)

Diagnostic Procedure

UBS00PDI

1. CHECK VIAS CONTROL SOLENOID VALVE POWER SUPPLY CIRCUIT

1. Turn ignition switch OFF.
 2. Disconnect VIAS control solenoid valve harness connector (2).
 3. Turn ignition switch ON.
- ↖: Vehicle front
 - Power valve actuator (1)

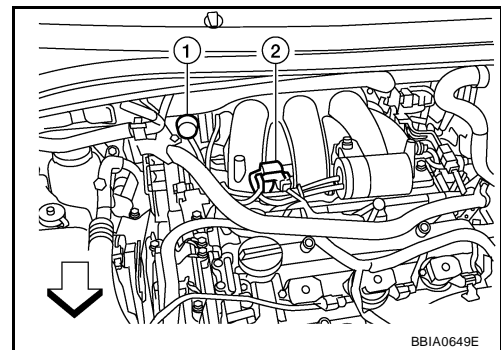

BBIA0649E

4. Check voltage between VIAS control solenoid valve terminal 1 and ground with CONSULT-II or tester.

Voltage: Battery voltage

OK or NG

- OK >> GO TO 3.
- NG >> GO TO 2.

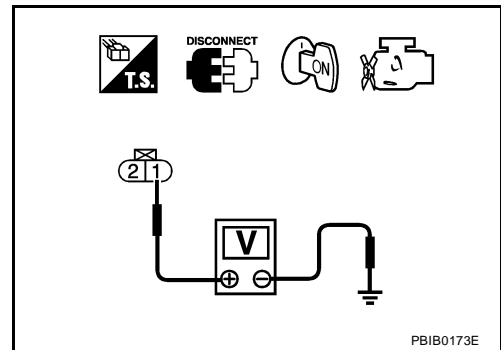

PBIB0173E

DTC P1800 VIAS CONTROL SOLENOID VALVE

2. DETECT MALFUNCTIONING PART

Check the following.

- Harness connectors E5, F14
- Harness for open or short between VIAS control solenoid valve and IPDM E/R
- Harness for open or short between VIAS control solenoid valve and ECM

>> Repair harness or connectors.

3. CHECK VIAS CONTROL SOLENOID VALVE OUTPUT SIGNAL CIRCUIT FOR OPEN AND SHORT

1. Turn ignition switch OFF.
2. Disconnect ECM harness connector.
3. Check harness continuity between ECM terminal 29 and VIAS control solenoid valve terminal 2. Refer to Wiring Diagram.

Continuity should exist.

4. Also check harness for short to ground and short to power.

OK or NG

OK >> GO TO 4.

NG >> Repair open circuit or short to ground or short to power in harness or connectors.

4. CHECK VIAS CONTROL SOLENOID VALVE

Refer to [EC-589, "Component Inspection"](#) .

OK or NG

OK >> GO TO 5.

NG >> Replace VIAS control solenoid valve.

5. CHECK INTERMITTENT INCIDENT

Refer to [EC-149, "TROUBLE DIAGNOSIS FOR INTERMITTENT INCIDENT"](#) .

>> INSPECTION END

Component Inspection VIAS CONTROL SOLENOID VALVE

UBS00PDJ

With CONSULT-II

1. Reconnect all harness connectors disconnected.
2. Turn ignition switch ON.
3. Perform "VIAS SOL VALVE" in "ACTIVE TEST" mode.
4. Check air passage continuity and operation delay time under the following conditions.

Condition VIAS SOL VALVE	Air passage continuity between A and B	Air passage continuity between A and C
ON	Yes	No
OFF	No	Yes

Operation takes less than 1 second.

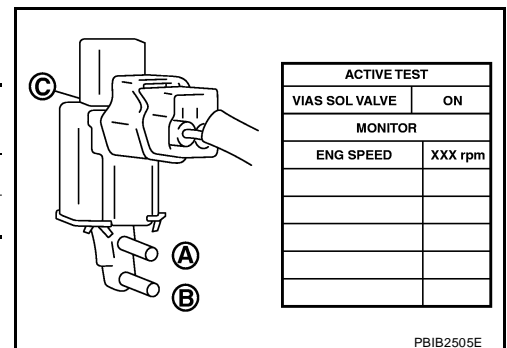

DTC P1800 VIAS CONTROL SOLENOID VALVE

⊗ Without CONSULT-II

Check air passage continuity and operation delay time under the following conditions.

Condition	Air passage continuity between A and B	Air passage continuity between A and C
12V direct current supply between terminals 1 and 2	Yes	No
No supply	No	Yes

Operation takes less than 1 second.

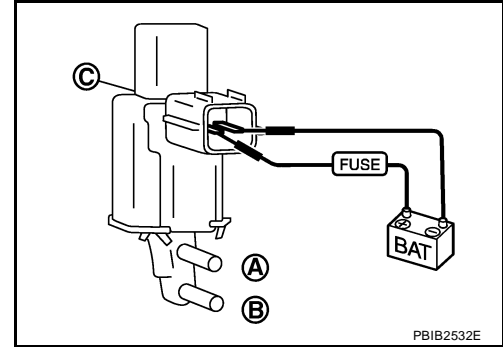

UBS00PDK

Removal and Installation VIAS CONTROL SOLENOID VALVE

Refer to [EM-24, "INTAKE MANIFOLD"](#) .

DTC P1805 BRAKE SWITCH

DTC P1805 BRAKE SWITCH

PF:25320

Description

UBS00PDL

Brake switch signal is applied to the ECM through the stop lamp switch when the brake pedal is depressed. This signal is used mainly to decrease the engine speed when the vehicle is driving.

CONSULT-II Reference Value in Data Monitor Mode

UBS00PDM

Specification data are reference values.

MONITOR ITEM	CONDITION		SPECIFICATION
BRAKE SW	● Ignition switch: ON	Brake pedal: Fully released	OFF
		Brake pedal: Slightly depressed	ON

On Board Diagnosis Logic

UBS00PDN

The MIL will not light up for this diagnosis.

DTC No.	Trouble diagnosis name	DTC detecting condition	Possible cause
P1805 1805	Brake switch	A brake switch signal is not sent to ECM for extremely long time while the vehicle is driving.	<ul style="list-style-type: none"> ● Harness or connectors (Stop lamp switch circuit is open or shorted.) ● Stop lamp switch

FAIL-SAFE MODE

When the malfunction is detected, the ECM enters fail-safe mode.

Engine operating condition in fail-safe mode	
ECM controls the electric throttle control actuator by regulating the throttle opening to a small range. Therefore, acceleration will be poor.	
Vehicle condition	Driving condition
When engine is idling	Normal
When accelerating	Poor acceleration

DTC Confirmation Procedure

UBS00PDO

WITH CONSULT-II

1. Turn ignition switch ON.
2. Fully depress the brake pedal for at least 5 seconds.
3. Erase the DTC with CONSULT-II.
4. Select "DATA MONITOR" mode with CONSULT-II.
5. If 1st trip DTC is detected, go to [EC-593, "Diagnostic Procedure"](#)

DATA MONITOR	
MONITOR	NO DTC
ENG SPEED	XXX rpm

SEF058Y

WITH GST

Follow the procedure "WITH CONSULT-II" above.

DTC P1805 BRAKE SWITCH

Wiring Diagram

UBS00PDP

EC-BRK/SW-01

: DETECTABLE LINE FOR DTC
 : NON-DETECTABLE LINE FOR DTC

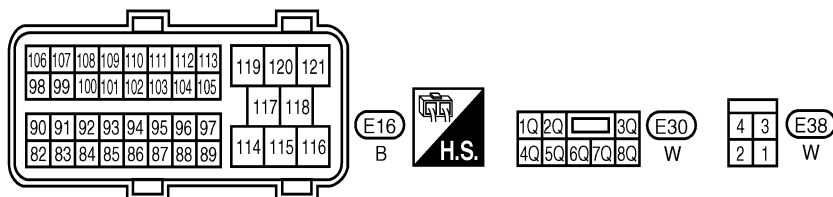
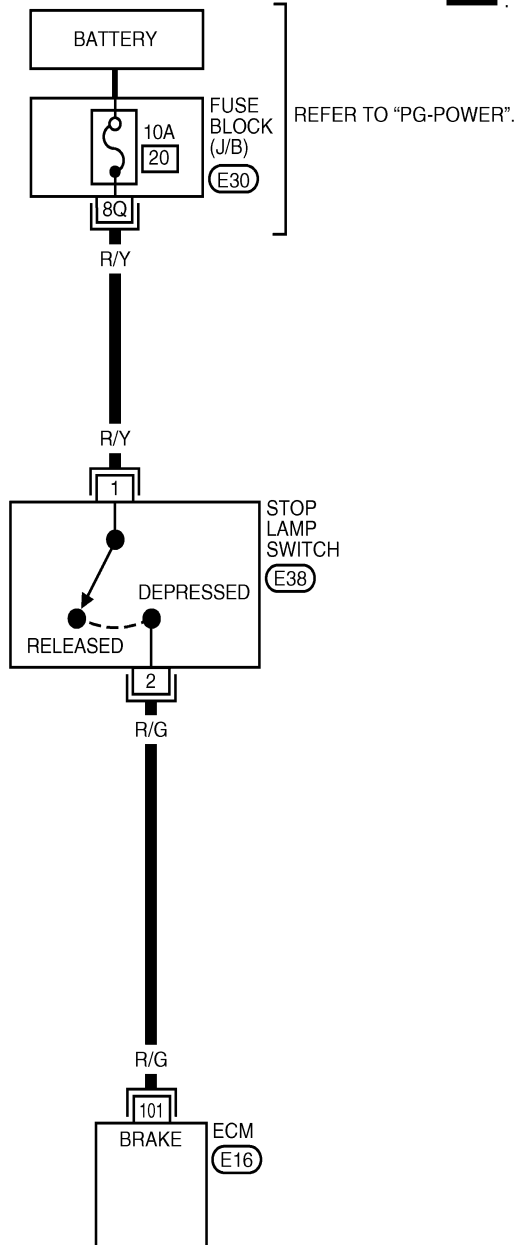

BBWA2534E

DTC P1805 BRAKE SWITCH

Specification data are reference values and are measured between each terminal and ground.

CAUTION:

Do not use ECM ground terminals when measuring input/output voltage. Doing so may result in damage to the ECM's transistor. Use a ground other than ECM terminals, such as the ground.

TER-MINAL NO.	WIRE COLOR	ITEM	CONDITION	DATA (DC Voltage)
101	R/G	Stop lamp switch	[Ignition switch: OFF] ● Brake pedal: Fully released	Approximately 0V
			[Ignition switch: OFF] ● Brake pedal: Slightly depressed	BATTERY VOLTAGE (11 - 14V)

Diagnostic Procedure

UBS00PDQ

1. CHECK STOP LAMP SWITCH CIRCUIT

1. Turn ignition switch OFF.
2. Check the stop lamp when depressing and releasing the brake pedal.

Brake pedal	Stop lamp
Fully released	Not illuminated
Slightly depressed	Illuminated

OK or NG

- OK >> GO TO 4.
- NG >> GO TO 2.

2. CHECK STOP LAMP SWITCH POWER SUPPLY CIRCUIT

1. Disconnect stop lamp switch harness connector.

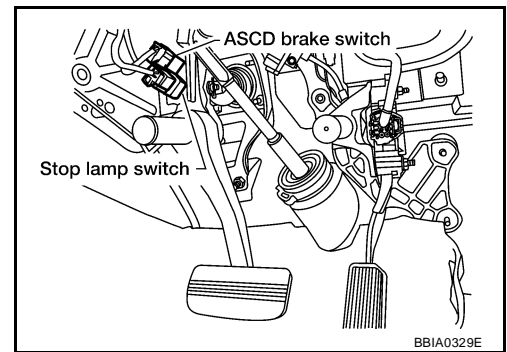

2. Check voltage between stop lamp switch terminal 1 and ground with CONSULT-II or tester.

Voltage: Battery voltage

OK or NG

- OK >> GO TO 4.
- NG >> GO TO 3.

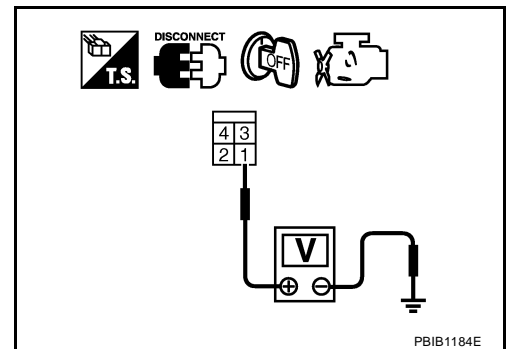

DTC P1805 BRAKE SWITCH

3. DETECT MALFUNCTIONING PART

Check the following.

- 10A fuse
- Fuse block (J/B) connector E30
- Harness for open and short between stop lamp switch and battery

>> Repair open circuit or short to ground or short to power in harness or connectors.

4. CHECK STOP LAMP SWITCH INPUT SIGNAL CIRCUIT FOR OPEN AND SHORT

1. Disconnect ECM harness connector.
2. Check harness continuity between ECM terminal 101 and stop lamp switch terminal 2.
Refer to Wiring Diagram.

Continuity should exist.

3. Also check harness for short to ground and short to power.

OK or NG

OK >> GO TO 5.

NG >> Repair open circuit or short to ground or short to power in harness or connectors.

5. CHECK STOP LAMP SWITCH

Refer to [EC-595, "Component Inspection"](#) .

OK or NG

OK >> GO TO 6.

NG >> Replace stop lamp switch.

6. CHECK INTERMITTENT INCIDENT

Refer to [EC-149, "TROUBLE DIAGNOSIS FOR INTERMITTENT INCIDENT"](#) .

>> **INSPECTION END**

DTC P1805 BRAKE SWITCH

UBS00PDR

Component Inspection STOP LAMP SWITCH

1. Disconnect stop lamp switch harness connector.

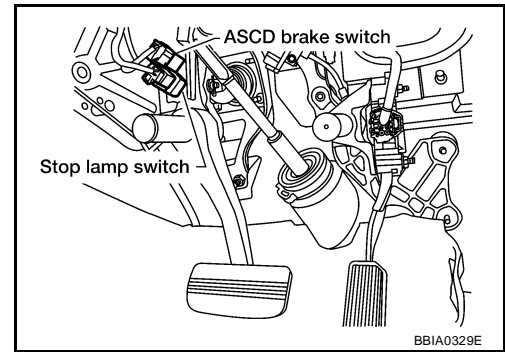

2. Check continuity between stop lamp switch terminals 1 and 2 under the following conditions.

Conditions	Continuity
Brake pedal: Fully released	Should not exist
Brake pedal: Slightly depressed	Should exist

3. If NG, adjust stop lamp switch installation, refer to [BR-6](#), "[BRAKE PEDAL](#)", and perform step 2 again.

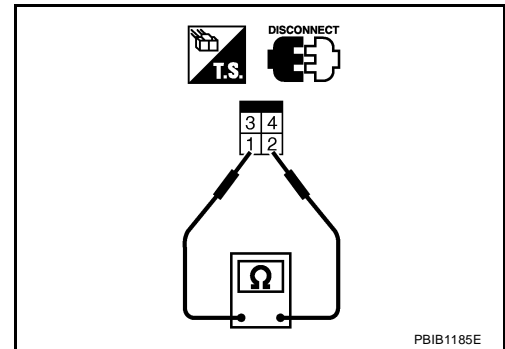

A
EC
C
D
E
F
G
H
I
J
K
L
M

DTC P2100, P2103 THROTTLE CONTROL MOTOR RELAY

DTC P2100, P2103 THROTTLE CONTROL MOTOR RELAY

PF16119

Component Description

UBS00PDS

Power supply for the throttle control motor is provided to the ECM via throttle control motor relay. The throttle control motor relay is ON/OFF controlled by the ECM. When the ignition switch is turned ON, the ECM sends an ON signal to throttle control motor relay and battery voltage is provided to the ECM. When the ignition switch is turned OFF, the ECM sends an OFF signal to throttle control motor relay and battery voltage is not provided to the ECM.

CONSULT-II Reference Value in Data Monitor Mode

UBS00PDU

Specification data are reference values.

MONITOR ITEM	CONDITION	SPECIFICATION
THRTL RELAY	● Ignition switch: ON	ON

On Board Diagnosis Logic

UBS00PDU

These self-diagnoses have the one trip detection logic.

DTC No.	Trouble diagnosis name	DTC detecting condition	Possible cause
P2100 2100	Throttle control motor relay circuit open	ECM detects a voltage of power source for throttle control motor is excessively low.	<ul style="list-style-type: none"> ● Harness or connectors (Throttle control motor relay circuit is open) ● Throttle control motor relay
P2103 2103	Throttle control motor relay circuit short	ECM detects the throttle control motor relay is stuck ON.	<ul style="list-style-type: none"> ● Harness or connectors (Throttle control motor relay circuit is shorted) ● Throttle control motor relay

FAIL-SAFE MODE

When the malfunction is detected, ECM enters fail-safe mode and the MIL lights up.

Engine operating condition in fail-safe mode

ECM stops the electric throttle control actuator control, throttle valve is maintained at a fixed opening (approx. 5 degrees) by the return spring.

DTC Confirmation Procedure

UBS00PDV

NOTE:

If DTC Confirmation Procedure has been previously conducted, always turn ignition switch OFF and wait at least 10 seconds before conducting the next test.

PROCEDURE FOR DTC P2100

④ With CONSULT-II

1. Turn ignition switch ON and wait at least 2 seconds.
2. Select "DATA MONITOR" mode with CONSULT-II.
3. Start engine and let it idle for 5 seconds.
4. If DTC is detected, go to [EC-599, "Diagnostic Procedure"](#).

DATA MONITOR	
MONITOR	NO DTC
ENG SPEED	XXX rpm

SEF058Y

④ With GST

Follow the procedure "With CONSULT-II" above.

DTC P2100, P2103 THROTTLE CONTROL MOTOR RELAY

PROCEDURE FOR DTC P2103

TESTING CONDITION:

Before performing the following procedure, confirm that battery voltage is more than 8V.

With CONSULT-II

1. Turn ignition switch ON and wait at least 1 second.
2. Select "DATA MONITOR" mode with CONSULT-II.
3. If DTC is detected, go to [EC-599, "Diagnostic Procedure"](#) .

DATA MONITOR	
MONITOR	NO DTC
ENG SPEED	XXX rpm

SEF058Y

With GST

Follow the procedure "With CONSULT-II" above.

A

EC

C

D

E

F

G

H

I

J

K

L

M

DTC P2100, P2103 THROTTLE CONTROL MOTOR RELAY

Wiring Diagram

UBS00PDW

EC-ETC2-01

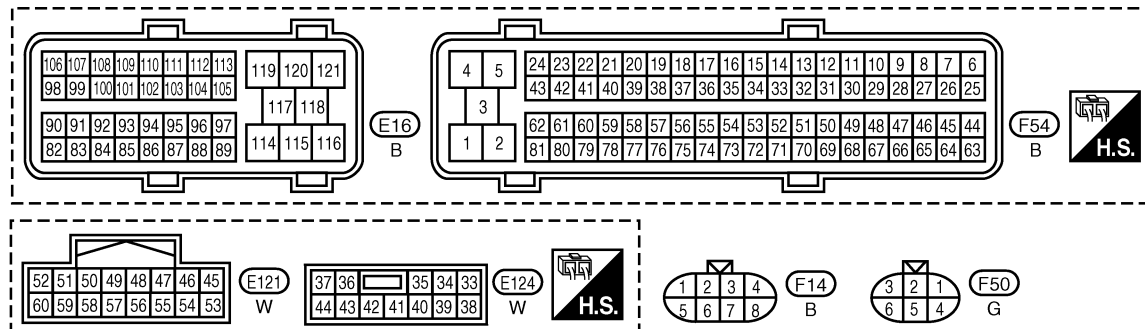
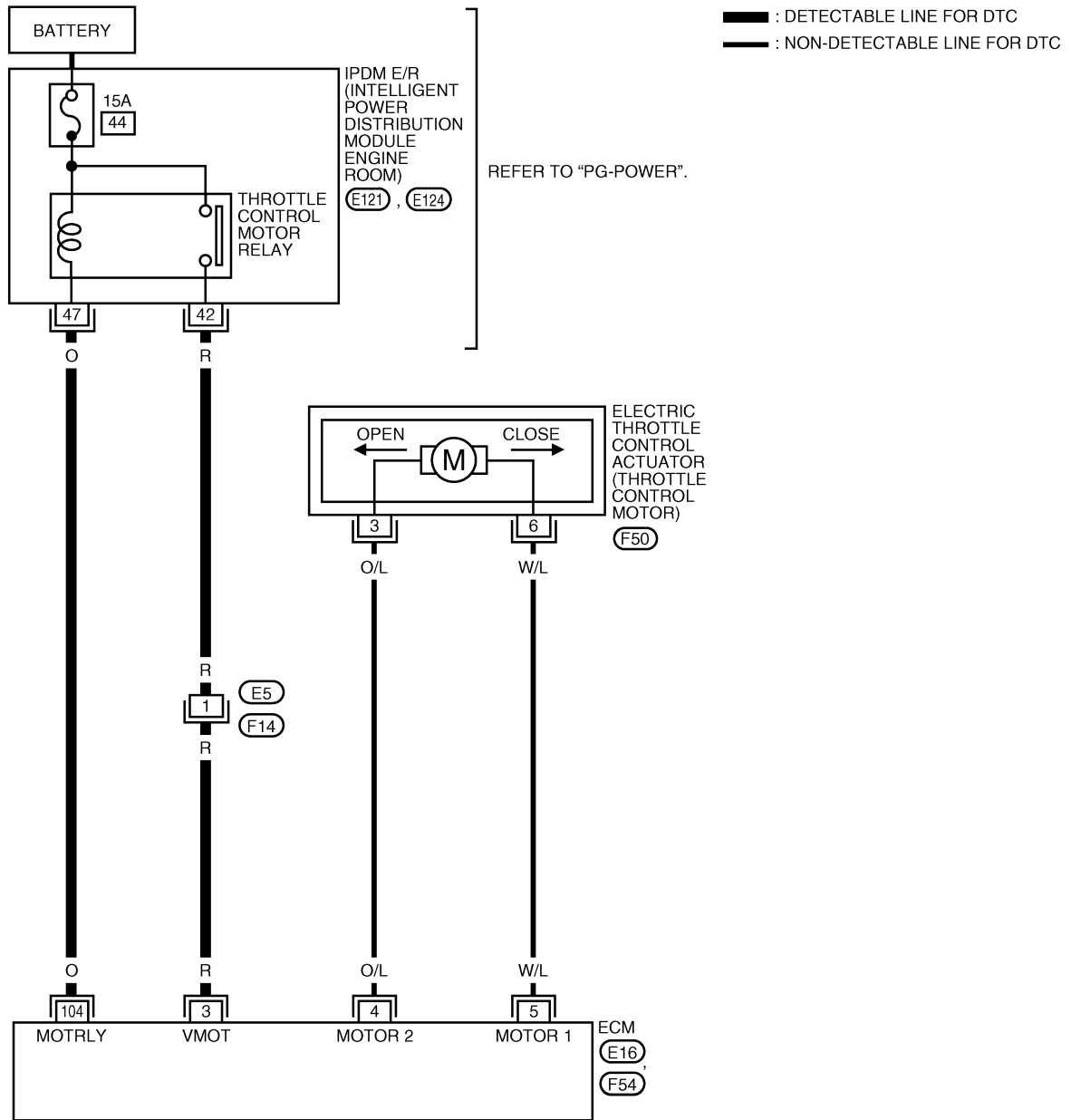

BBWA2526E

DTC P2100, P2103 THROTTLE CONTROL MOTOR RELAY

Specification data are reference values and are measured between each terminal and ground. Pulse signal is measured by CONSULT-II.

CAUTION:

Do not use ECM ground terminals when measuring input/output voltage. Doing so may result in damage to the ECM's transistor. Use a ground other than ECM terminals, such as the ground.

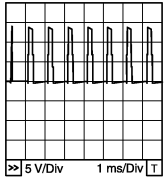
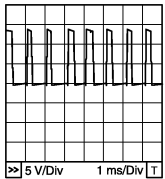
TER-MINAL NO.	WIRE COLOR	ITEM	CONDITION	DATA (DC Voltage)
3	R	Throttle control motor relay power supply	[Ignition switch: ON]	BATTERY VOLTAGE (11 - 14V)
4	O/L	Throttle control motor (Close)	[Ignition switch: ON] ● Engine stopped ● Shift lever: D ● Accelerator pedal: Fully released	0 - 14V★  PBIB1104E
5	W/L	Throttle control motor (Open)	[Ignition switch: ON] ● Engine stopped ● Shift lever: D ● Accelerator pedal: Fully depressed	0 - 14V★  PBIB1105E
104	O	Throttle control motor relay	[Ignition switch: OFF]	BATTERY VOLTAGE (11 - 14V)
			[Ignition switch: ON]	0 - 1.0V

★: Average voltage for pulse signal (Actual pulse signal can be confirmed by oscilloscope.)

Diagnostic Procedure

UBS00PDX

1. CHECK THROTTLE CONTROL MOTOR RELAY POWER SUPPLY CIRCUIT-I

- Turn ignition switch OFF.
- Check voltage between ECM terminal 104 and ground with CONSULT-II or tester.

Voltage: Battery voltage

OK or NG

- OK >> GO TO 4.
NG >> GO TO 2.

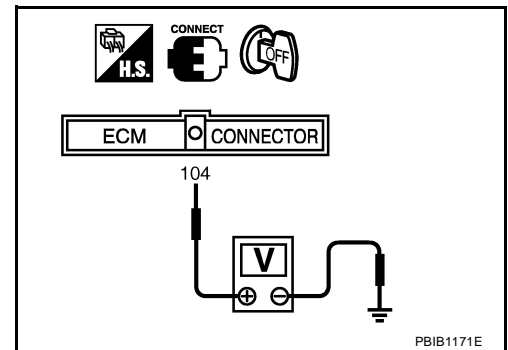

DTC P2100, P2103 THROTTLE CONTROL MOTOR RELAY

2. CHECK THROTTLE CONTROL MOTOR RELAY POWER SUPPLY CIRCUIT-II

1. Disconnect ECM harness connector.
2. Disconnect IPDM E/R harness connector E121.
3. Check continuity between ECM terminal 104 and IPDM E/R terminal 47.
Refer to Wiring Diagram.

Continuity should exist.

4. Also check harness for short to ground and short to power.

OK or NG

OK >> GO TO 3.

NG >> Repair open circuit or short to ground or short to power in harness or connectors.

3. CHECK FUSE

1. Disconnect 15A fuse.
2. Check 15A fuse for blown.

OK or NG

OK >> GO TO 7.

NG >> Replace 15A fuse.

4. CHECK THROTTLE CONTROL MOTOR RELAY INPUT SIGNAL CIRCUIT-I

Check voltage between ECM terminal 3 and ground under the following conditions with CONSULT-II or tester.

Ignition switch	Voltage
OFF	Approximately 0V
ON	Battery voltage (11 - 14V)

OK or NG

OK >> GO TO 7.

NG >> GO TO 5.

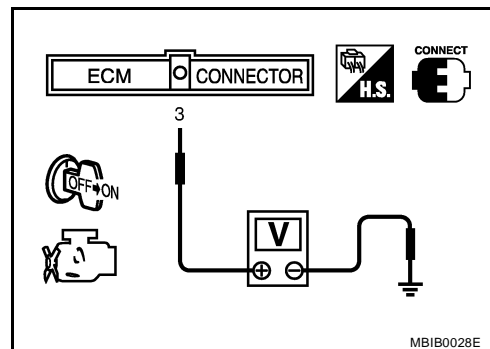

5. CHECK THROTTLE CONTROL MOTOR RELAY INPUT SIGNAL CIRCUIT-II

1. Turn ignition switch OFF.
2. Disconnect ECM harness connector.
3. Disconnect IPDM E/R harness connector E124.
4. Check continuity between ECM terminal 3 and IPDM E/R terminal 42.
Refer to Wiring Diagram.

Continuity should exist.

5. Also check harness for short to ground and short to power.

OK or NG

OK >> GO TO 7.

NG >> GO TO 6.

6. DETECT MALFUNCTIONING PART

Check the following.

- Harness connectors E5, F14
- Harness for open or short between ECM and IPDM E/R

>> Repair open circuit or short to ground or short to power in harness or connectors.

DTC P2100, P2103 THROTTLE CONTROL MOTOR RELAY

7. CHECK INTERMITTENT INCIDENT

Refer to [EC-149, "TROUBLE DIAGNOSIS FOR INTERMITTENT INCIDENT"](#) .

OK or NG

- OK >> Replace IPDM E/R. Refer to [PG-18, "IPDM E/R \(INTELLIGENT POWER DISTRIBUTION MODULE ENGINE ROOM\)"](#) .
- NG >> Repair or replace harness or connectors.

A

EC

C

D

E

F

G

H

I

J

K

L

M

DTC P2101 ELECTRIC THROTTLE CONTROL FUNCTION

DTC P2101 ELECTRIC THROTTLE CONTROL FUNCTION

PF16119

Description

UBS00PDY

NOTE:

If DTC P2101 is displayed with DTC P2100 or P2119, first perform the trouble diagnosis for DTC P2100 or P2119. Refer to [EC-596, "DTC P2100, P2103 THROTTLE CONTROL MOTOR RELAY"](#) or [EC-615, "DTC P2119 ELECTRIC THROTTLE CONTROL ACTUATOR"](#).

Electric throttle control actuator consists of throttle control motor, throttle position sensor, etc.

The throttle control motor is operated by the ECM and it opens and closes the throttle valve.

The current opening angle of the throttle valve is detected by the throttle position sensor and it provides feedback to the ECM to control the throttle control motor to make the throttle valve opening angle properly in response to driving condition.

On Board Diagnosis Logic

UBS00PDZ

This self-diagnosis has the one trip detection logic.

DTC No.	Trouble diagnosis name	DTC detecting condition	Possible cause
P2101 2101	Electric throttle control performance	Electric throttle control function does not operate properly.	<ul style="list-style-type: none">● Harness or connectors (Throttle control motor circuit is open or shorted)● Electric throttle control actuator

FAIL-SAFE MODE

When the malfunction is detected, ECM enters fail-safe mode and the MIL lights up.

Engine operating condition in fail-safe mode

ECM stops the electric throttle control actuator control, throttle valve is maintained at a fixed opening (approx. 5 degrees) by the return spring.

DTC Confirmation Procedure

UBS00PE0

TESTING CONDITION:

- Before performing the following procedure, confirm that battery voltage is more than 11V at idle.

NOTE:

If DTC Confirmation Procedure has been previously conducted, always turn ignition switch OFF and wait at least 10 seconds before conducting the next test.

WITH CONSULT-II

1. Turn ignition switch ON and wait at least 2 seconds.
2. Select "DATA MONITOR" mode with CONSULT-II.
3. Start engine and let it idle for 5 seconds.
4. If DTC is detected, go to [EC-605, "Diagnostic Procedure"](#).

DATA MONITOR	
MONITOR	NO DTC
ENG SPEED	XXX rpm

SEF058Y

WITH GST

Follow the procedure "WITH CONSULT-II" above.

DTC P2101 ELECTRIC THROTTLE CONTROL FUNCTION

Wiring Diagram

UBS00PE1

EC-ETC1-01

A
EC
C
D
E
F
G
H
I
J
K
L
M

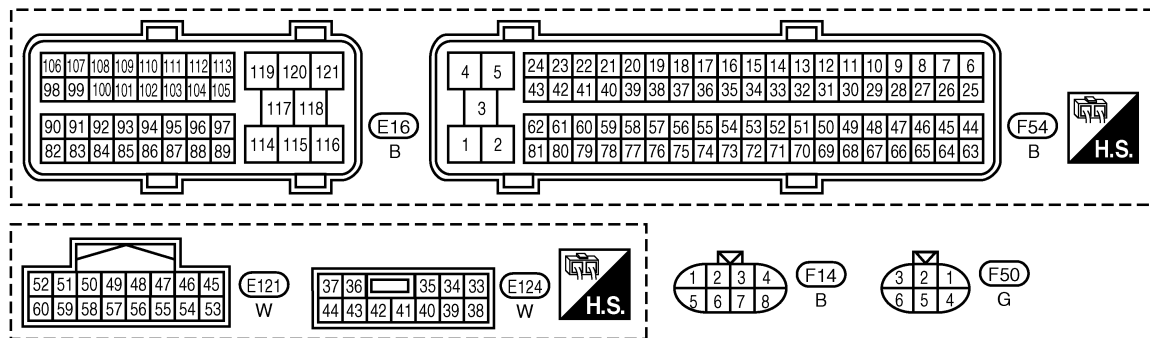
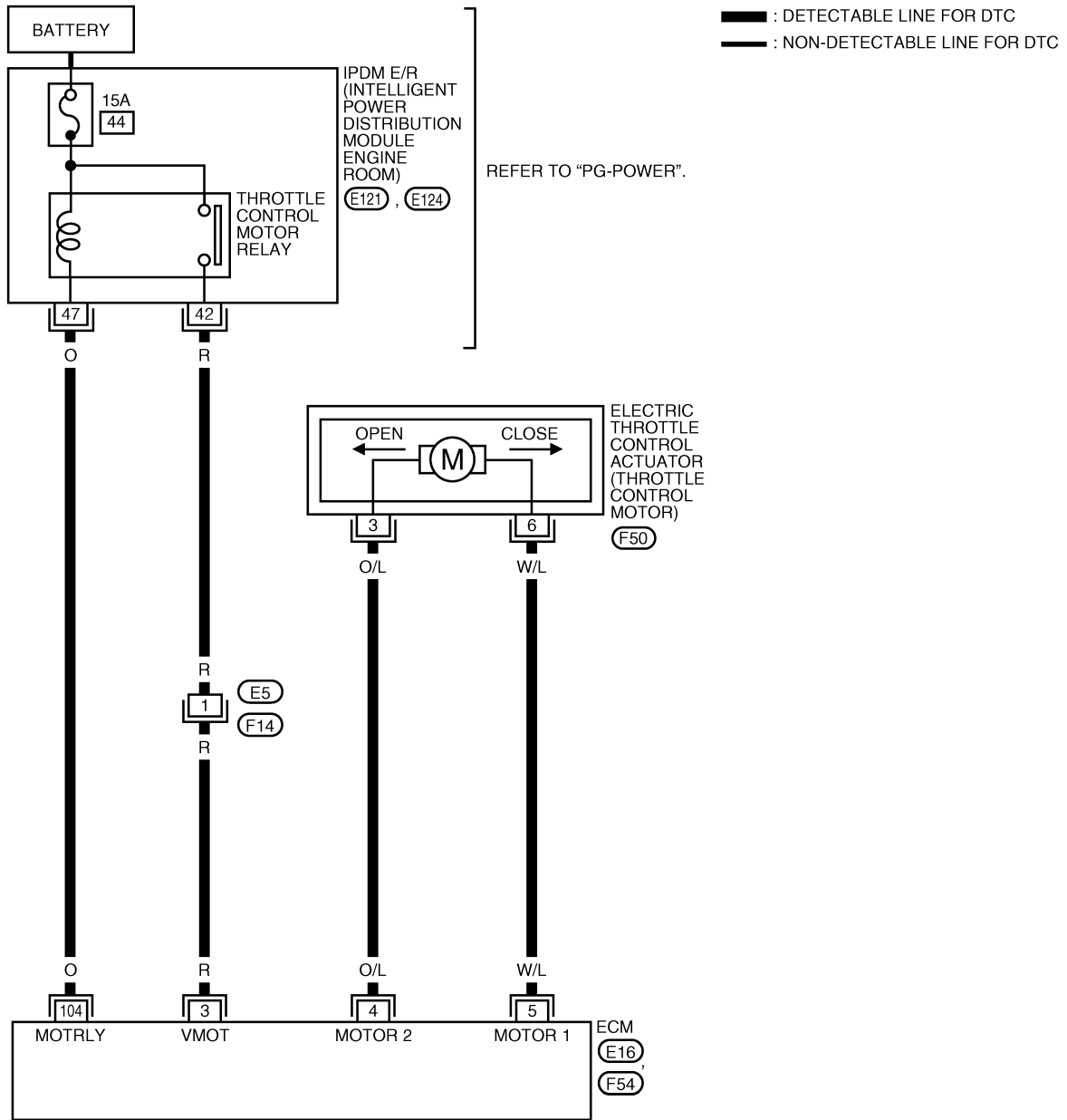

BBWA2525E

DTC P2101 ELECTRIC THROTTLE CONTROL FUNCTION

Specification data are reference values and are measured between each terminal and ground.
Pulse signal is measured by CONSULT-II.

CAUTION:

Do not use ECM ground terminals when measuring input/output voltage. Doing so may result in damage to the ECM's transistor. Use a ground other than ECM terminals, such as the ground.

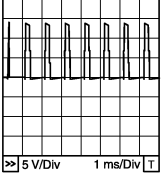
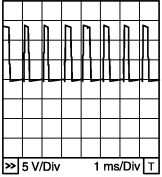
TER-MINAL NO.	WIRE COLOR	ITEM	CONDITION	DATA (DC Voltage)
3	R	Throttle control motor relay power supply	[Ignition switch: ON]	BATTERY VOLTAGE (11 - 14V)
4	O/L	Throttle control motor (Close)	[Ignition switch: ON] <ul style="list-style-type: none"> ● Engine stopped ● Shift lever: D ● Accelerator pedal: Fully released 	0 - 14V★ 
5	W/L	Throttle control motor (Open)	[Ignition switch: ON] <ul style="list-style-type: none"> ● Engine stopped ● Shift lever: D ● Accelerator pedal: Fully depressed 	0 - 14V★ 
104	O	Throttle control motor relay	[Ignition switch: OFF]	BATTERY VOLTAGE (11 - 14V)
			[Ignition switch: ON]	0 - 1.0V

★: Average voltage for pulse signal (Actual pulse signal can be confirmed by oscilloscope.)

DTC P2101 ELECTRIC THROTTLE CONTROL FUNCTION

UBS00PE2

Diagnostic Procedure

1. CHECK GROUND CONNECTIONS

1. Turn ignition switch OFF.
2. Loosen and retighten three ground screws on the body. Refer to [EC-158, "Ground Inspection"](#).

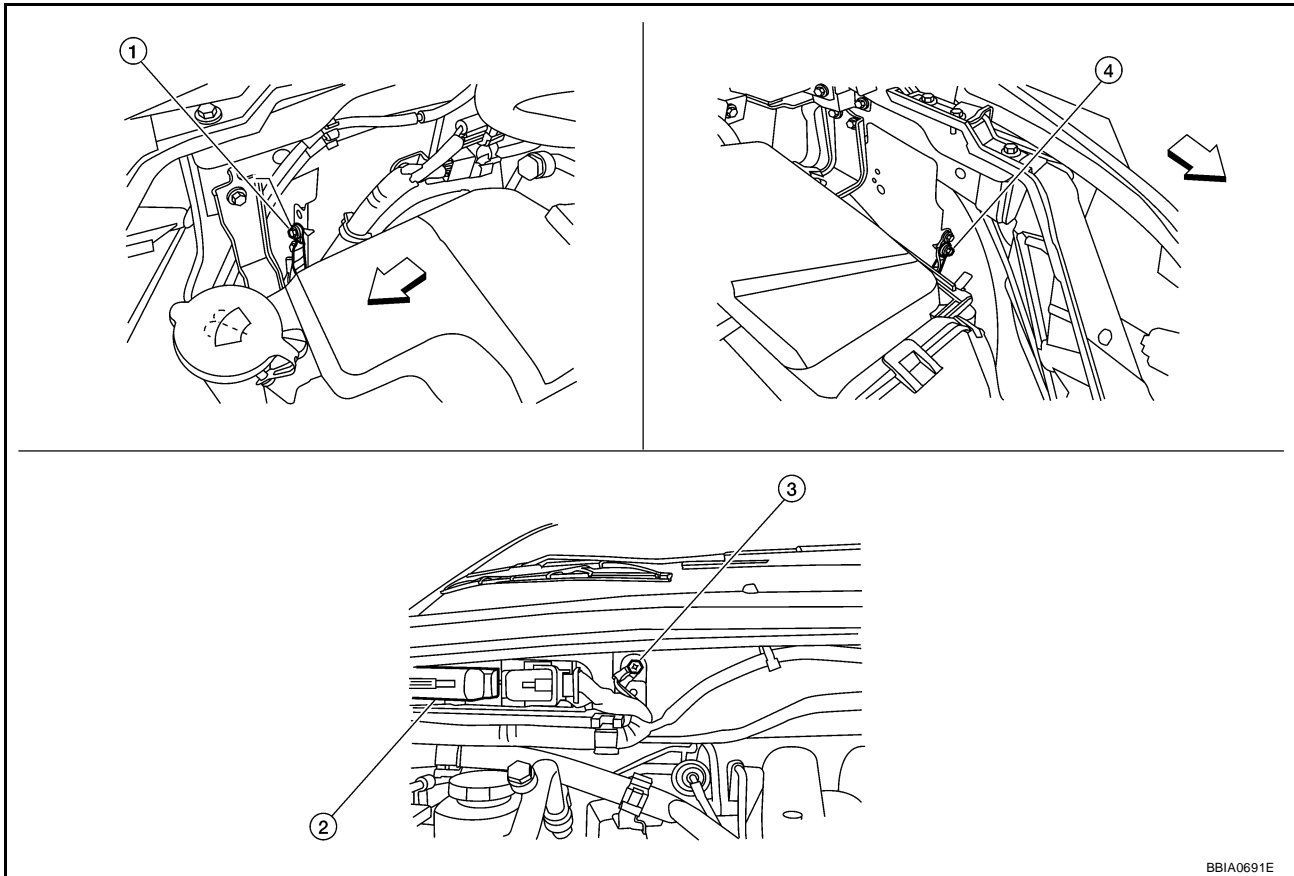

← Vehicle front

1. Body ground E24

2. ECM

3. Body ground E9

4. Body ground E15

OK or NG

OK >> GO TO 2.

NG >> Repair or replace ground connections.

2. CHECK THROTTLE CONTROL MOTOR RELAY INPUT SIGNAL CIRCUIT-I

Check voltage between ECM terminal 3 and ground under the following conditions with CONSULT-II or tester.

Ignition switch	Voltage
OFF	Approximately 0V
ON	Battery voltage (11 - 14V)

OK or NG

OK >> GO TO 9.

NG >> GO TO 3.

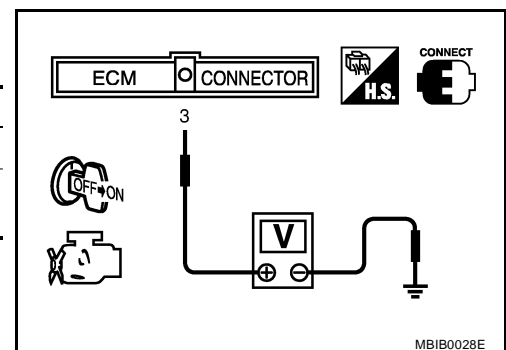

MBIB0028E

DTC P2101 ELECTRIC THROTTLE CONTROL FUNCTION

3. CHECK THROTTLE CONTROL MOTOR RELAY POWER SUPPLY CIRCUIT-I

1. Turn ignition switch OFF.
2. Check voltage between ECM terminal 104 and ground with CONSULT-II or tester.

Voltage: Battery voltage

OK or NG

- OK >> GO TO 6.
NG >> GO TO 4.

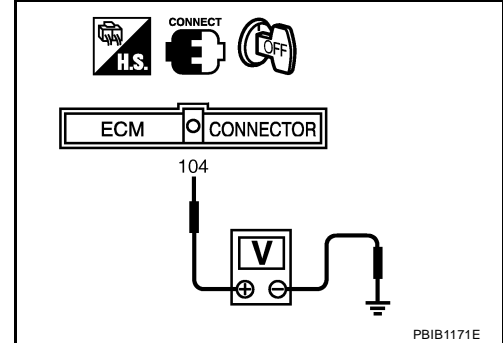

4. CHECK THROTTLE CONTROL MOTOR RELAY POWER SUPPLY CIRCUIT-II

1. Disconnect ECM harness connector.
2. Disconnect IPDM E/R harness connector E121.
3. Check continuity between ECM terminal 104 and IPDM E/R terminal 47.
Refer to Wiring Diagram.

Continuity should exist.

4. Also check harness for short to ground and short to power.

OK or NG

- OK >> GO TO 5.
NG >> Repair open circuit or short to ground or short to power in harness or connectors.

5. CHECK FUSE

1. Disconnect 15A fuse.
2. Check 15A fuse for blown.

OK or NG

- OK >> GO TO 8.
NG >> Replace 15A fuse.

6. CHECK THROTTLE CONTROL MOTOR RELAY INPUT SIGNAL CIRCUIT-II

1. Disconnect ECM harness connector.
2. Disconnect IPDM E/R harness connector E124.
3. Check continuity between ECM terminal 3 and IPDM E/R terminal 42.
Refer to Wiring Diagram.

Continuity should exist.

4. Also check harness for short to ground and short to power.

OK or NG

- OK >> GO TO 8.
NG >> GO TO 7.

7. DETECT MALFUNCTIONING PART

Check the following.

- Harness connectors E5, F14
- Harness for open or short between ECM and IPDM E/R

>> Repair open circuit or short to ground or short to power in harness or connectors.

DTC P2101 ELECTRIC THROTTLE CONTROL FUNCTION

8. CHECK INTERMITTENT INCIDENT

Refer to [EC-149, "TROUBLE DIAGNOSIS FOR INTERMITTENT INCIDENT"](#) .

OK or NG

- OK >> Replace IPDM E/R. Refer to [PG-18, "IPDM E/R \(INTELLIGENT POWER DISTRIBUTION MODULE ENGINE ROOM\)"](#) .
- NG >> Repair or replace harness or connectors.

9. CHECK THROTTLE CONTROL MOTOR OUTPUT SIGNAL CIRCUIT FOR OPEN OR SHORT

1. Turn ignition switch OFF.
2. Disconnect electric throttle control actuator harness connector.
3. Disconnect ECM harness connector.
4. Check harness continuity between the following terminals.
Refer to Wiring Diagram.

Electric throttle control actuator terminal	ECM terminal	Continuity
3	5	Should not exist
	4	Should exist
6	5	Should exist
	4	Should not exist

5. Also check harness for short to ground and short to power.

OK or NG

- OK >> GO TO 10.
- NG >> Repair or replace.

10. CHECK ELECTRIC THROTTLE CONTROL ACTUATOR VISUALLY

1. Remove the intake air duct.
2. Check if foreign matter is caught between the throttle valve and the housing.

OK or NG

- OK >> GO TO 11.
- NG >> Remove the foreign matter and clean the electric throttle control actuator inside.

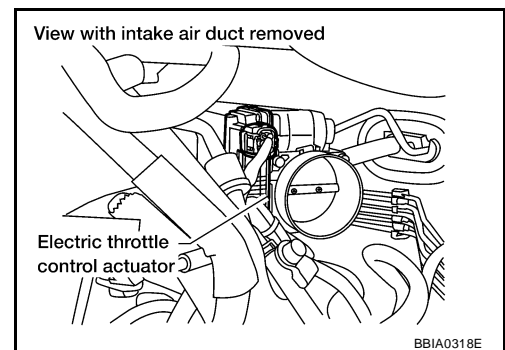
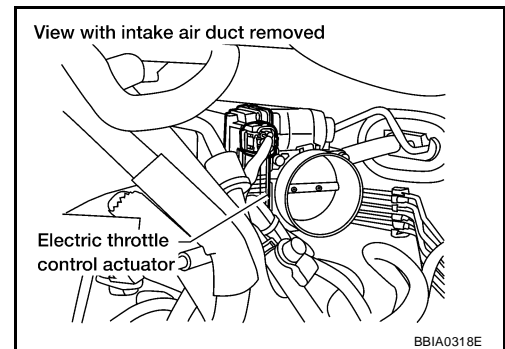

11. CHECK THROTTLE CONTROL MOTOR

Refer to [EC-608, "Component Inspection"](#) .

OK or NG

- OK >> GO TO 12.
- NG >> GO TO 13.

12. CHECK INTERMITTENT INCIDENT

Refer to [EC-149, "TROUBLE DIAGNOSIS FOR INTERMITTENT INCIDENT"](#) .

OK or NG

- OK >> GO TO 13.
- NG >> Repair or replace harness or connectors.

DTC P2101 ELECTRIC THROTTLE CONTROL FUNCTION

13. REPLACE ELECTRIC THROTTLE CONTROL ACTUATOR

1. Replace the electric throttle control actuator.
2. Perform [EC-80, "Throttle Valve Closed Position Learning"](#) .
3. Perform [EC-80, "Idle Air Volume Learning"](#) .

>> INSPECTION END

Component Inspection THROTTLE CONTROL MOTOR

UBS00PE3

1. Disconnect electric throttle control actuator harness connector.
2. Check resistance between terminals 3 and 6.

Resistance: Approximately 1 - 15 Ω [at 25 °C (77°F)]

3. If NG, replace electric throttle control actuator and go to next step.
4. Perform [EC-80, "Throttle Valve Closed Position Learning"](#) .
5. Perform [EC-80, "Idle Air Volume Learning"](#) .

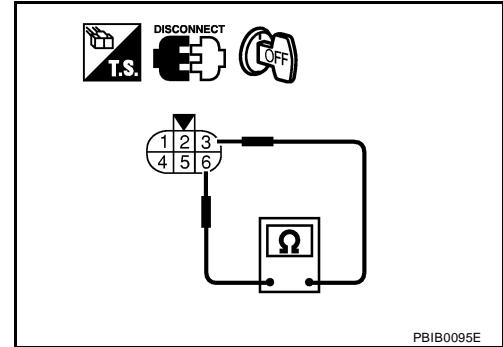

Removal and Installation ELECTRIC THROTTLE CONTROL ACTUATOR

UBS00PE4

Refer to [EM-24, "INTAKE MANIFOLD"](#) .

DTC P2118 THROTTLE CONTROL MOTOR

DTC P2118 THROTTLE CONTROL MOTOR

PFP:16119

Component Description

UBS00PE5

The throttle control motor is operated by the ECM and it opens and closes the throttle valve. The current opening angle of the throttle valve is detected by the throttle position sensor and it provides feedback to the ECM to control the throttle control motor to make the throttle valve opening angle properly in response to driving condition.

On Board Diagnosis Logic

UBS00PE6

This self-diagnosis has the one trip detection logic.

DTC No.	Trouble diagnosis name	DTC detecting condition	Possible cause
P2118 2118	Throttle control motor circuit short	ECM detects short in both circuits between ECM and throttle control motor.	<ul style="list-style-type: none">● Harness or connectors (Throttle control motor circuit is shorted.)● Electric throttle control actuator (Throttle control motor)

FAIL-SAFE MODE

When the malfunction is detected, the ECM enters fail-safe mode and the MIL lights up.

Engine operating condition in fail-safe mode

ECM stops the electric throttle control actuator control, throttle valve is maintained at a fixed opening (approx. 5 degrees) by the return spring.

DTC Confirmation Procedure

UBS00PE7

NOTE:

If DTC Confirmation Procedure has been previously conducted, always turn ignition switch OFF and wait at least 10 seconds before conducting the next test.

WITH CONSULT-II

1. Turn ignition switch ON and wait at least 2 seconds.
2. Select "DATA MONITOR" mode with CONSULT-II.
3. Start engine and let it idle for 5 seconds.
4. If DTC is detected, go to [EC-612, "Diagnostic Procedure"](#).

DATA MONITOR	
MONITOR	NO DTC
ENG SPEED	XXX rpm

SEF058Y

WITH GST

Follow the procedure "WITH CONSULT-II" above.

DTC P2118 THROTTLE CONTROL MOTOR

UBS00PE8

Wiring Diagram

EC-ETC3-01

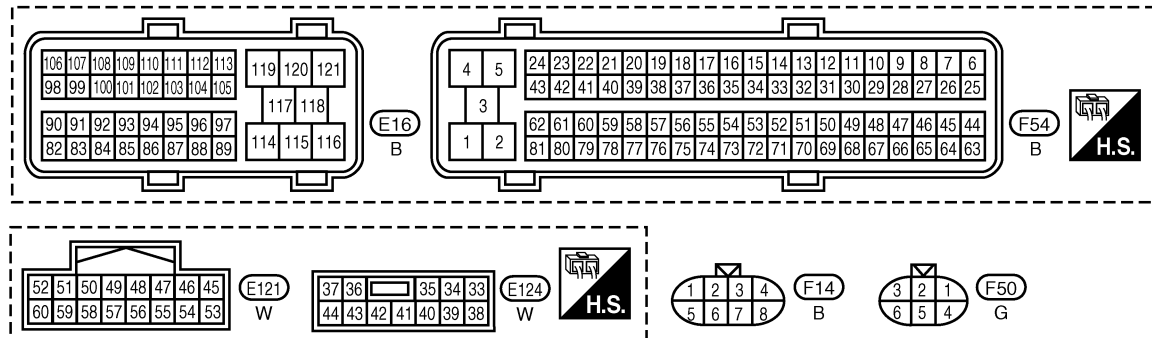
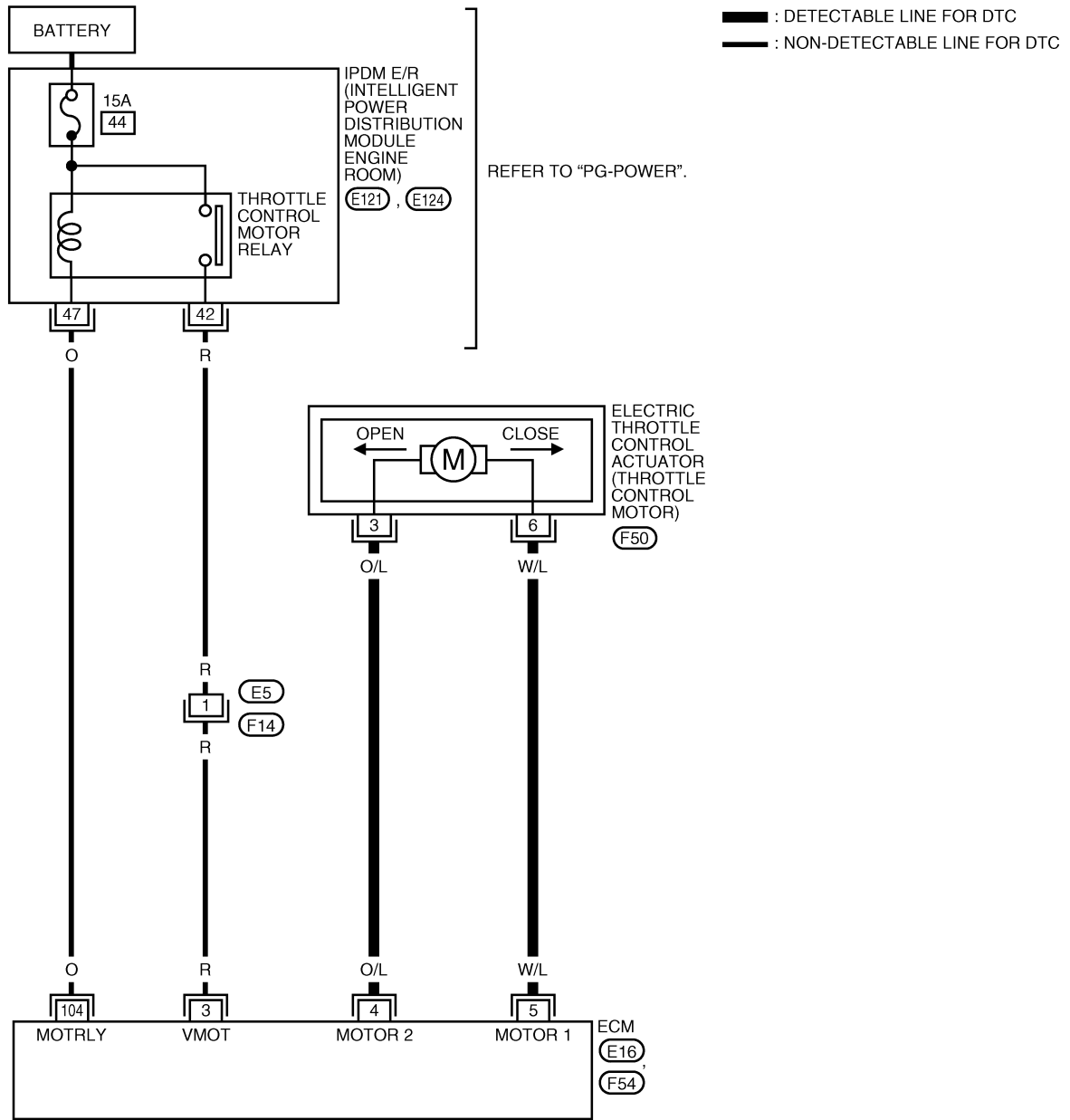

BBWA2527E

DTC P2118 THROTTLE CONTROL MOTOR

Specification data are reference values and are measured between each terminal and ground. Pulse signal is measured by CONSULT-II.

CAUTION:

Do not use ECM ground terminals when measuring input/output voltage. Doing so may result in damage to the ECM's transistor. Use a ground other than ECM terminals, such as the ground.

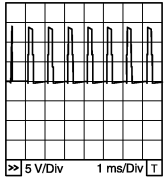
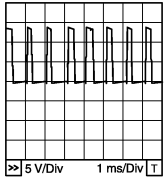
TER-MINAL NO.	WIRE COLOR	ITEM	CONDITION	DATA (DC Voltage)
3	R	Throttle control motor relay power supply	[Ignition switch: ON]	BATTERY VOLTAGE (11 - 14V)
4	O/L	Throttle control motor (Close)	[Ignition switch: ON] <ul style="list-style-type: none"> ● Engine stopped ● Shift lever: D ● Accelerator pedal: Fully released 	0 - 14V★ 
5	W/L	Throttle control motor (Open)	[Ignition switch: ON] <ul style="list-style-type: none"> ● Engine stopped ● Shift lever: D ● Accelerator pedal: Fully depressed 	0 - 14V★ 
104	O	Throttle control motor relay	[Ignition switch: OFF]	BATTERY VOLTAGE (11 - 14V)
			[Ignition switch: ON]	0 - 1.0V

★: Average voltage for pulse signal (Actual pulse signal can be confirmed by oscilloscope.)

DTC P2118 THROTTLE CONTROL MOTOR

UBS00PE9

Diagnostic Procedure

1. CHECK GROUND CONNECTIONS

1. Turn ignition switch OFF.
2. Loosen and retighten three ground screws on the body. Refer to [EC-158, "Ground Inspection"](#).

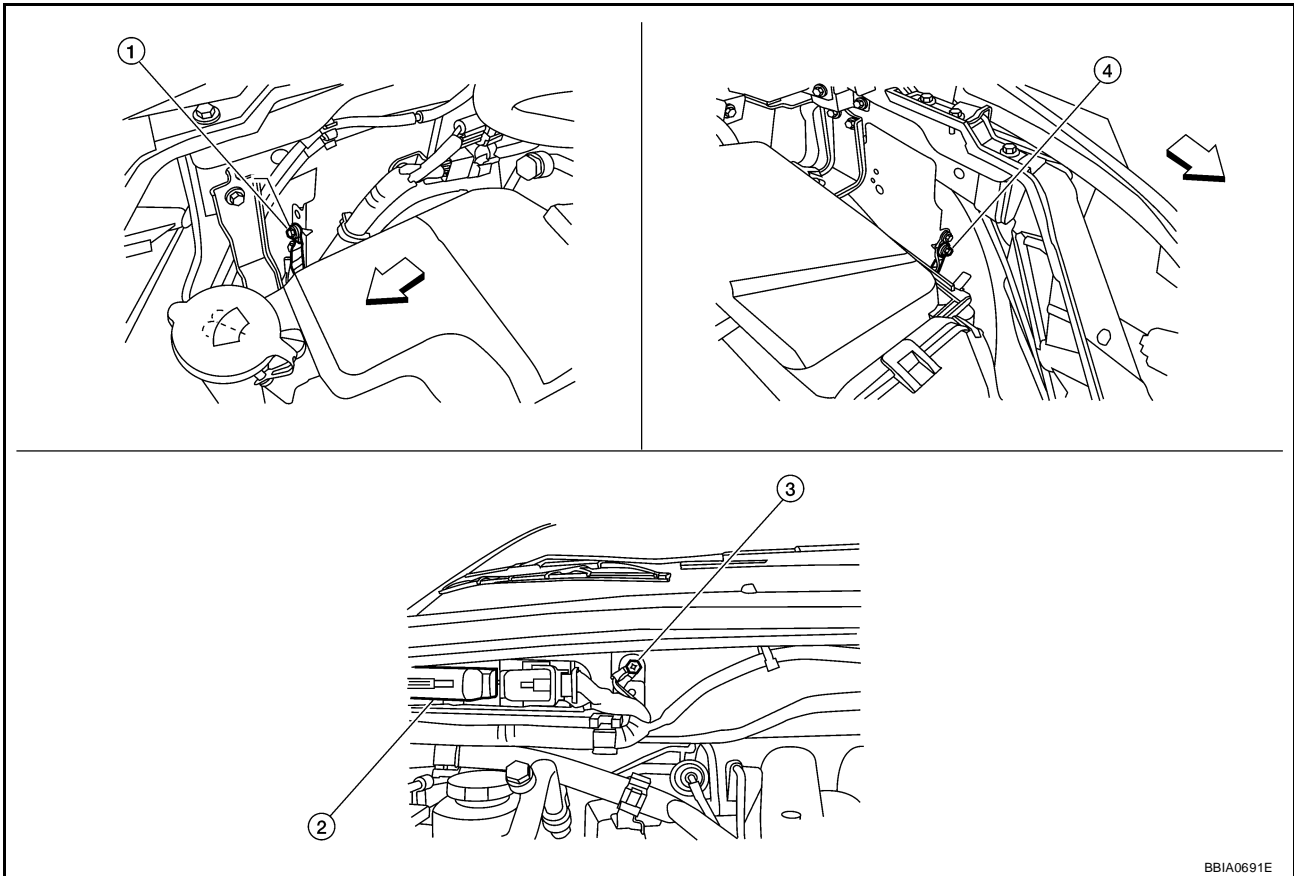

BBA0691E

← Vehicle front

1. Body ground E24

2. ECM

3. Body ground E9

4. Body ground E15

OK or NG

OK >> GO TO 2.

NG >> Repair or replace ground connections.

DTC P2118 THROTTLE CONTROL MOTOR

2. CHECK THROTTLE CONTROL MOTOR OUTPUT SIGNAL CIRCUIT FOR OPEN OR SHORT

1. Disconnect electric throttle control actuator harness connector.
2. Disconnect ECM harness connector.
3. Check harness continuity between the following terminals.
Refer to Wiring Diagram.

Electric throttle control actuator terminal	ECM terminal	Continuity
3	5	Should not exist
	4	Should exist
6	5	Should exist
	4	Should not exist

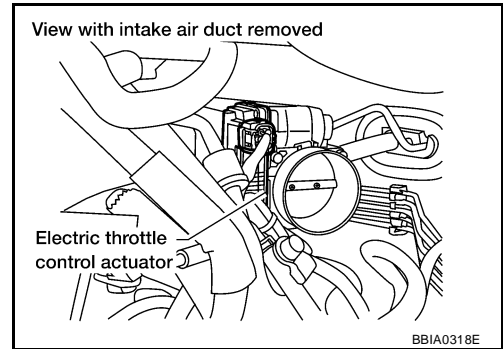

4. Also check harness for short to ground and short to power.

OK or NG

- OK >> GO TO 3.
- NG >> Repair or replace.

3. CHECK THROTTLE CONTROL MOTOR

Refer to [EC-613, "Component Inspection"](#) .

OK or NG

- OK >> GO TO 4.
- NG >> GO TO 5.

4. CHECK INTERMITTENT INCIDENT

Refer to [EC-149, "TROUBLE DIAGNOSIS FOR INTERMITTENT INCIDENT"](#) .

OK or NG

- OK >> GO TO 5.
- NG >> Repair or replace harness or connectors.

5. REPLACE ELECTRIC THROTTLE CONTROL ACTUATOR

1. Replace the electric throttle control actuator.
2. Perform [EC-80, "Throttle Valve Closed Position Learning"](#) .
3. Perform [EC-80, "Idle Air Volume Learning"](#) .

>> INSPECTION END

Component Inspection THROTTLE CONTROL MOTOR

UBS00PEA

1. Disconnect electric throttle control actuator harness connector.
2. Check resistance between terminals 3 and 6.

Resistance: Approximately 1 - 15 Ω [at 25 °C (77°F)]

3. If NG, replace electric throttle control actuator and go to next step.
4. Perform [EC-80, "Throttle Valve Closed Position Learning"](#) .
5. Perform [EC-80, "Idle Air Volume Learning"](#) .

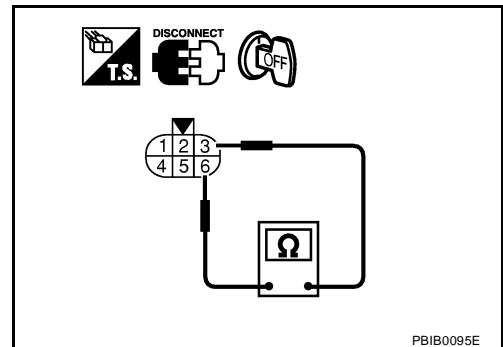

DTC P2118 THROTTLE CONTROL MOTOR

Removal and Installation ELECTRIC THROTTLE CONTROL ACTUATOR

UBS00PEB

Refer to [EM-18, "INTAKE MANIFOLD COLLECTOR"](#) .

DTC P2119 ELECTRIC THROTTLE CONTROL ACTUATOR

DTC P2119 ELECTRIC THROTTLE CONTROL ACTUATOR

PF16119

Component Description

UBS00PEC

Electric throttle control actuator consists of throttle control motor, throttle position sensor, etc. The throttle control motor is operated by the ECM and it opens and closes the throttle valve. The throttle position sensor detects the throttle valve position, and the opening and closing speed of the throttle valve and feeds the voltage signals to the ECM. The ECM judges the current opening angle of the throttle valve from these signals and the ECM controls the throttle control motor to make the throttle valve opening angle properly in response to driving condition.

On Board Diagnosis Logic

UBS00PED

This self-diagnosis has the one trip detection logic.

DTC No.	Trouble diagnosis name	DTC detecting condition		Possible cause
P2119 2119	Electric throttle control actuator	A)	Electric throttle control actuator does not function properly due to the return spring malfunction.	● Electric throttle control actuator
		B)	Throttle valve opening angle in fail-safe mode is not in specified range.	
		C)	ECM detect the throttle valve is stuck open.	

FAIL-SAFE MODE

When the malfunction is detected, the ECM enters fail-safe mode and the MIL lights up.

Detected items	Engine operating condition in fail-safe mode
Malfunction A	The ECM controls the electric throttle actuator by regulating the throttle opening around the idle position. The engine speed will not rise more than 2,000 rpm.
Malfunction B	ECM controls the electric throttle control actuator by regulating the throttle opening to 20 degrees or less.
Malfunction C	While the vehicle is driving, it slows down gradually by fuel cut. After the vehicle stops, the engine stalls. The engine can restart in N or P position, and engine speed will not exceed 1,000 rpm or more.

DTC Confirmation Procedure

UBS00PEE

NOTE:

- Perform **PROCEDURE FOR MALFUNCTION A AND B** first. If the 1st trip DTC cannot be confirmed, perform **PROCEDURE FOR MALFUNCTION C**.
- If DTC Confirmation Procedure has been previously conducted, always turn ignition switch OFF and wait at least 10 seconds before conducting the next test.

PROCEDURE FOR MALFUNCTION A AND B

With CONSULT-II

1. Turn ignition switch ON and wait at least 1 second.
2. Select "DATA MONITOR" mode with CONSULT-II.
3. Set shift lever to D position and wait at least 3 seconds.
4. Set shift lever to N or P position.
5. Turn ignition switch OFF and wait at least 10 second.
6. Turn ignition switch ON and wait at least 1 second.
7. Set shift lever to D position and wait at least 3 seconds.
8. Set shift lever to N or P position.
9. Turn ignition switch OFF, wait at least 10 seconds, and then turn ON.
10. If DTC is detected, go to [EC-616. "Diagnostic Procedure"](#).

DATA MONITOR	
MONITOR	NO DTC
ENG SPEED	XXX rpm

SEF058Y

With GST

Follow the procedure "With CONSULT-II" above.

DTC P2119 ELECTRIC THROTTLE CONTROL ACTUATOR

PROCEDURE FOR MALFUNCTION C

With CONSULT-II

1. Turn ignition switch ON and wait at least 1 second.
2. Select "DATA MONITOR" mode with CONSULT-II.
3. Set shift lever to D position and wait at least 3 seconds.
4. Set shift lever to P or N position.
5. Start engine and let it idle for 3 seconds.
6. If DTC is detected, go to [EC-616, "Diagnostic Procedure"](#) .

DATA MONITOR	
MONITOR	NO DTC
ENG SPEED	XXX rpm

SEF058Y

With GST

Follow the procedure "With CONSULT-II" above.

Diagnostic Procedure

UBS00PEF

1. CHECK ELECTRIC THROTTLE CONTROL ACTUATOR VISUALLY

1. Remove the intake air duct.
2. Check if a foreign matter is caught between the throttle valve and the housing.

OK or NG

- OK >> GO TO 2.
NG >> Remove the foreign matter and clean the electric throttle control actuator inside.

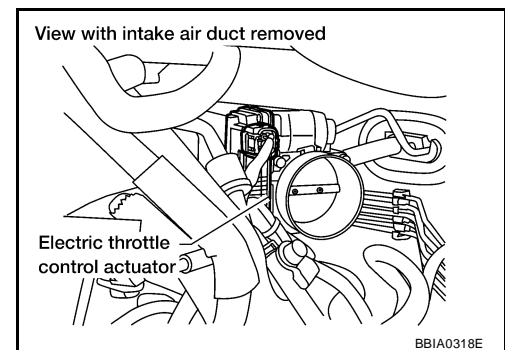

2. REPLACE ELECTRIC THROTTLE CONTROL ACTUATOR

1. Replace the electric throttle control actuator.
2. Perform [EC-80, "Throttle Valve Closed Position Learning"](#) .
3. Perform [EC-80, "Idle Air Volume Learning"](#) .

>> INSPECTION END

DTC P2122, P2123 APP SENSOR

PFP:18002

DTC P2122, P2123 APP SENSOR

Component Description

UBS00PEG

The accelerator pedal position sensor is installed on the upper end of the accelerator pedal assembly. The sensor detects the accelerator position and sends a signal to the ECM.

Accelerator pedal position sensor has two sensors. These sensors are a kind of potentiometers which transform the accelerator pedal position into output voltage, and emit the voltage signal to the ECM. In addition, these sensors detect the opening and closing speed of the accelerator pedal and feed the voltage signals to the ECM. The ECM judges the current opening angle of the accelerator pedal from these signals and controls the throttle control motor based on these signals.

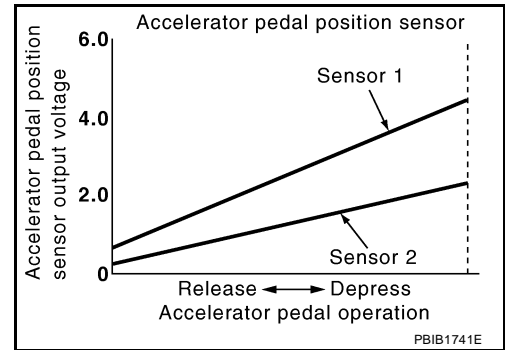

Idle position of the accelerator pedal is determined by the ECM receiving the signal from the accelerator pedal position sensor. The ECM uses this signal for the engine operation such as fuel cut.

CONSULT-II Reference Value in Data Monitor Mode

UBS00PEH

Specification data are reference values.

MONITOR ITEM	CONDITION		SPECIFICATION
ACCEL SEN 1 ACCEL SEN 2*	● Ignition switch: ON (Engine stopped)	Accelerator pedal: Fully released	0.5 - 1.0V
		Accelerator pedal: Fully depressed	4.2 - 4.8V
CLSD THL POS	● Ignition switch: ON (Engine stopped)	Accelerator pedal: Fully released	ON
		Accelerator pedal: Slightly depressed	OFF

*: Accelerator pedal position sensor 2 signal is converted by ECM internally. Thus, it differ from ECM terminal voltage.

On Board Diagnosis Logic

UBS00PEI

These self-diagnoses have the one trip detection logic.

NOTE:

If DTC P2122 or P2123 is displayed with DTC P0643, first perform the trouble diagnosis for DTC P0643. Refer to [EC-529, "DTC P0643 SENSOR POWER SUPPLY"](#).

DTC No.	Trouble diagnosis name	DTC detecting condition	Possible cause
P2122 2122	Accelerator pedal position sensor 1 circuit low input	An excessively low voltage from the APP sensor 1 is sent to ECM.	● Harness or connectors (The APP sensor 1 circuit is open or shorted.) ● Accelerator pedal position sensor (APP sensor 1)
P2123 2123	Accelerator pedal position sensor 1 circuit high input	An excessively high voltage from the APP sensor 1 is sent to ECM.	

FAIL-SAFE MODE

When the malfunction is detected, ECM enters fail-safe mode and the MIL lights up.

Engine operating condition in fail-safe mode

The ECM controls the electric throttle control actuator in regulating the throttle opening in order for the idle position to be within +10 degrees.

The ECM regulates the opening speed of the throttle valve to be slower than the normal condition.

So, the acceleration will be poor.

DTC P2122, P2123 APP SENSOR

UBS00PEJ

DTC Confirmation Procedure

NOTE:

If DTC Confirmation Procedure has been previously conducted, always turn ignition switch OFF and wait at least 10 seconds before conducting the next test.

TESTING CONDITION:

Before performing the following procedure, confirm that battery voltage is more than 10V at idle.

④ WITH CONSULT-II

1. Turn ignition switch ON.
2. Select "DATA MONITOR" mode with CONSULT-II.
3. Start engine and let it idle for 1 second.
4. If DTC is detected, go to [EC-621, "Diagnostic Procedure"](#) .

DATA MONITOR	
MONITOR	NO DTC
ENG SPEED	XXX rpm

SEF058Y

④ WITH GST

Follow the procedure "WITH CONSULT-II" above.

DTC P2122, P2123 APP SENSOR

Wiring Diagram

UBS00PEK

EC-APPS1-01

: DETECTABLE LINE FOR DTC
 : NON-DETECTABLE LINE FOR DTC

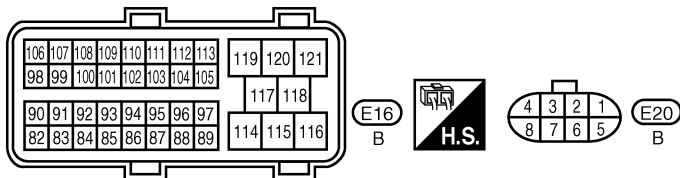
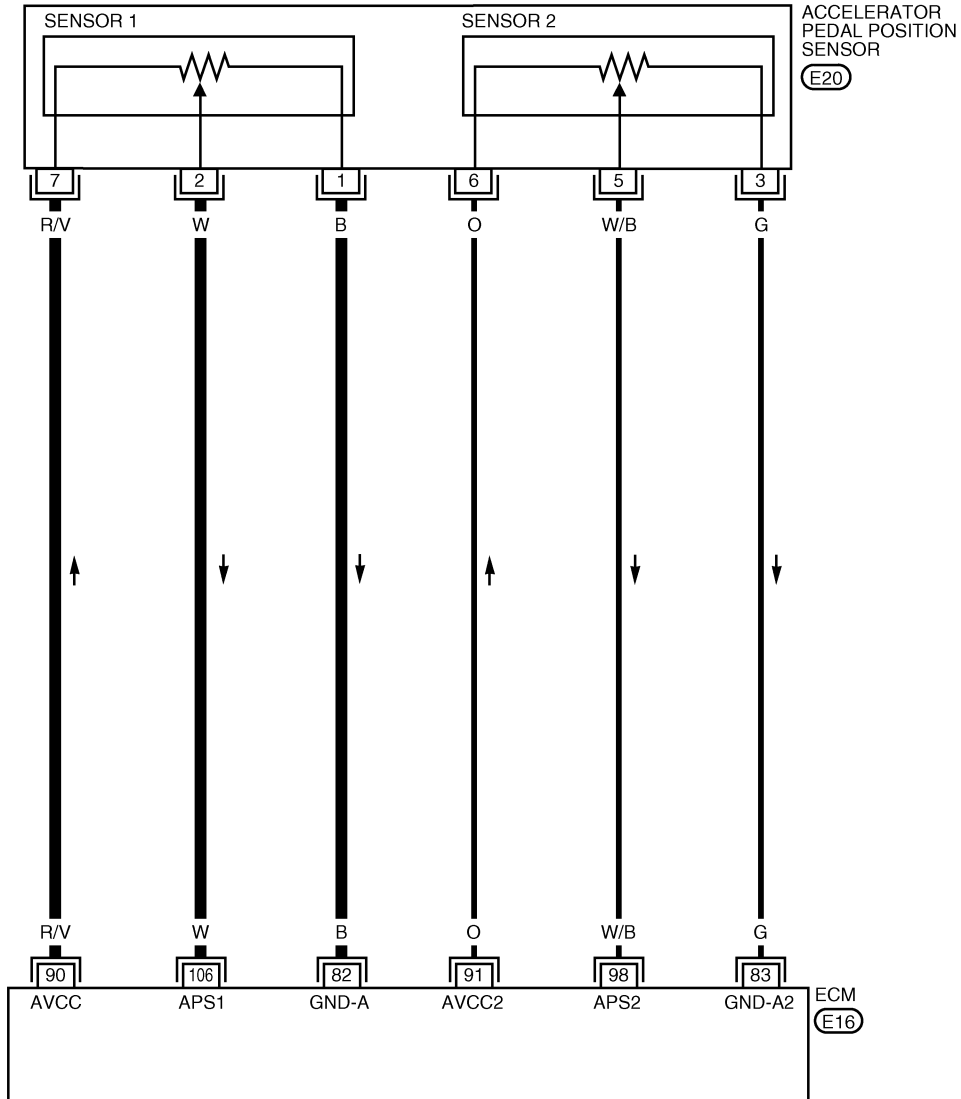

BBWA2026E

DTC P2122, P2123 APP SENSOR

Specification data are reference values and are measured between each terminal and ground.

CAUTION:

Do not use ECM ground terminals when measuring input/output voltage. Doing so may result in damage to the ECM's transistor. Use a ground other than ECM terminals, such as the ground.

TER-MINAL NO.	WIRE COLOR	ITEM	CONDITION	DATA (DC Voltage)
82	B	APP sensor 1 ground	[Engine is running] <ul style="list-style-type: none"> ● Warm-up condition ● Idle speed 	Approximately 0V
83	G	APP sensor 2 ground	[Engine is running] <ul style="list-style-type: none"> ● Warm-up condition ● Idle speed 	Approximately 0V
90	R/V	APP sensor 1 power supply	[Ignition switch: ON]	Approximately 5V
91	O	APP sensor 2 power supply	[Ignition switch: ON]	Approximately 5V
98	W/B	Accelerator pedal position sensor 2	[Ignition switch: ON] <ul style="list-style-type: none"> ● Engine stopped ● Accelerator pedal: Fully released 	0.25 - 0.5V
			[Ignition switch: ON] <ul style="list-style-type: none"> ● Engine stopped ● Accelerator pedal: Fully depressed 	2.0 - 2.5V
106	W	Accelerator pedal position sensor 1	[Ignition switch: ON] <ul style="list-style-type: none"> ● Engine stopped ● Accelerator pedal: Fully released 	0.5 - 1.0V
			[Ignition switch: ON] <ul style="list-style-type: none"> ● Engine stopped ● Accelerator pedal: Fully depressed 	4.2 - 4.8V

DTC P2122, P2123 APP SENSOR

UBS00PEL

Diagnostic Procedure

1. CHECK GROUND CONNECTIONS

1. Turn ignition switch OFF.
2. Loosen and retighten three ground screws on the body. Refer to [EC-158, "Ground Inspection"](#).

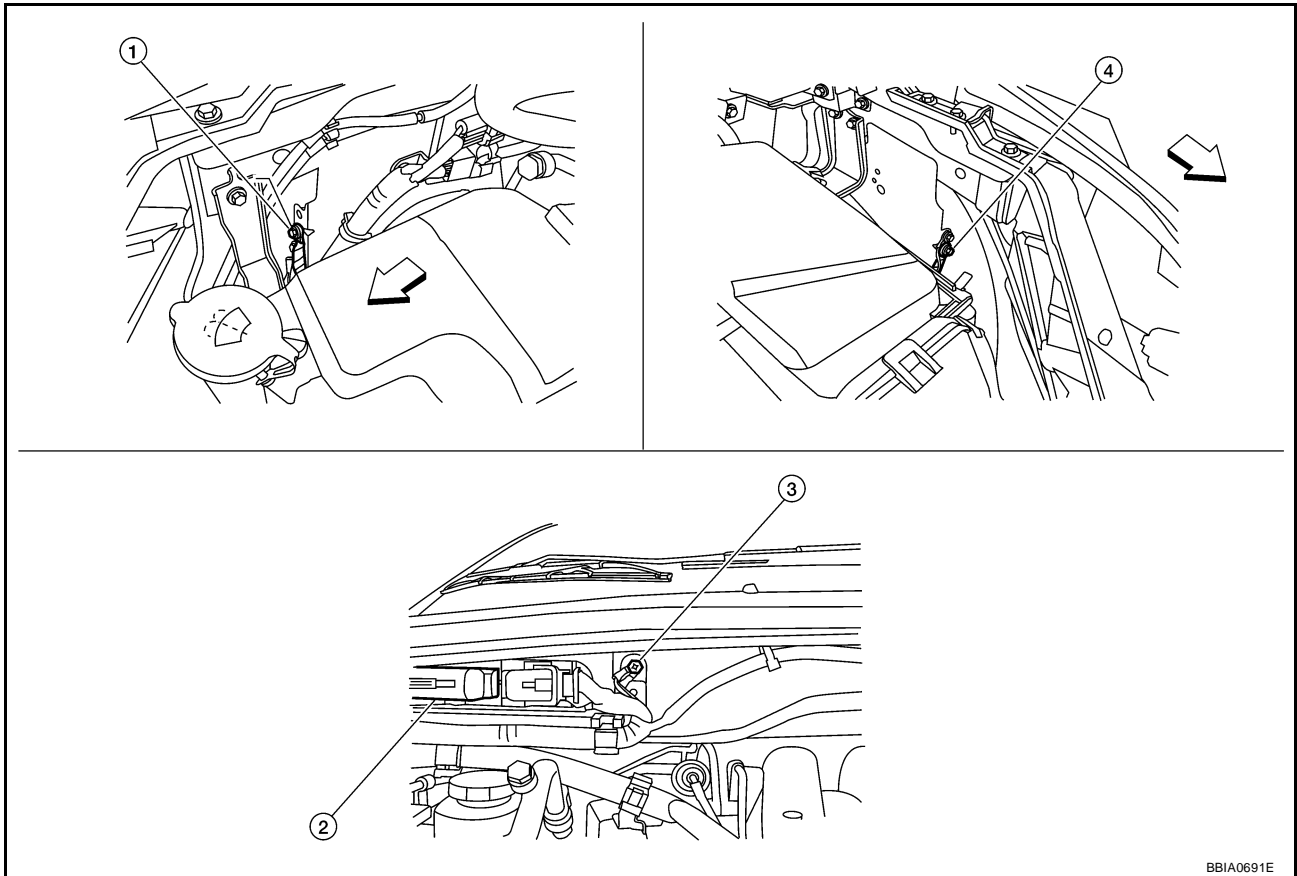

↔ Vehicle front

1. Body ground E24

2. ECM

3. Body ground E9

4. Body ground E15

OK or NG

OK >> GO TO 2.

NG >> Repair or replace ground connections.

DTC P2122, P2123 APP SENSOR

2. CHECK APP SENSOR 1 POWER SUPPLY CIRCUIT

1. Disconnect accelerator pedal position (APP) sensor harness connector.
2. Turn ignition switch ON.

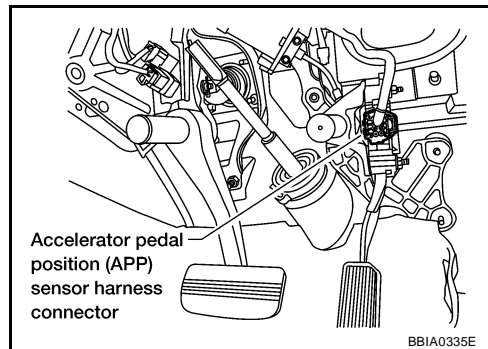

3. Check voltage between APP sensor terminal 7 and ground with CONSULT-II or tester.

Voltage: Approximately 5V

OK or NG

OK >> GO TO 3.

NG >> Repair open circuit or short to ground or short to power in harness or connectors.

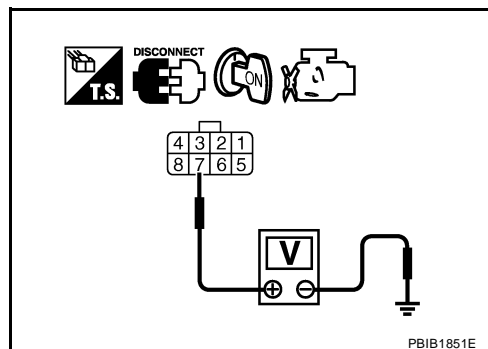

3. CHECK APP SENSOR 1 GROUND CIRCUIT FOR OPEN AND SHORT

1. Turn ignition switch OFF.
2. Disconnect ECM harness connector.
3. Check harness continuity between ECM terminal 82 and APP sensor terminal 1. Refer to Wiring Diagram.

Continuity should exist.

4. Also check harness for short to ground and short to power.

OK or NG

OK >> GO TO 4.

NG >> Repair open circuit or short to ground or short to power in harness or connectors.

4. CHECK APP SENSOR INPUT SIGNAL CIRCUIT FOR OPEN AND SHORT

1. Check harness continuity between ECM terminal 106 and APP sensor terminal 2. Refer to Wiring Diagram.

Continuity should exist.

2. Also check harness for short to ground and short to power.

OK or NG

OK >> GO TO 5.

NG >> Repair open circuit or short to ground or short to power in harness or connectors.

5. CHECK APP SENSOR

Refer to [EC-623, "Component Inspection"](#).

OK or NG

OK >> GO TO 7.

NG >> GO TO 6.

DTC P2122, P2123 APP SENSOR

6. REPLACE ACCELERATOR PEDAL ASSEMBLY

1. Replace accelerator pedal assembly.
2. Perform [EC-80, "Accelerator Pedal Released Position Learning"](#) .
3. Perform [EC-80, "Throttle Valve Closed Position Learning"](#) .
4. Perform [EC-80, "Idle Air Volume Learning"](#) .

>> INSPECTION END

7. CHECK INTERMITTENT INCIDENT

Refer to [EC-149, "TROUBLE DIAGNOSIS FOR INTERMITTENT INCIDENT"](#) .

>> INSPECTION END

Component Inspection ACCELERATOR PEDAL POSITION SENSOR

UBS00PEM

1. Reconnect all harness connectors disconnected.
2. Turn ignition switch ON.
3. Check voltage between ECM terminals 106 (APP sensor 1 signal), 98 (APP sensor 2 signal) and ground under the following conditions.

Terminal	Accelerator pedal	Voltage
106 (Accelerator pedal position sensor 1)	Fully released	0.5 - 1.0V
	Fully depressed	4.2 - 4.8V
98 (Accelerator pedal position sensor 2)	Fully released	0.25 - 0.5V
	Fully depressed	0.2 - 2.5V

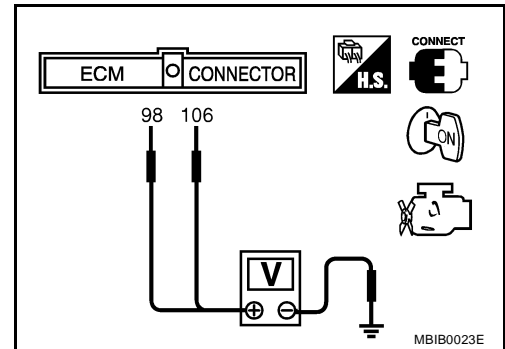

4. If NG, replace accelerator pedal assembly and go to next step.
5. Perform [EC-80, "Accelerator Pedal Released Position Learning"](#) .
6. Perform [EC-80, "Throttle Valve Closed Position Learning"](#) .
7. Perform [EC-80, "Idle Air Volume Learning"](#) .

Removal and Installation ACCELERATOR PEDAL

UBS00PEN

Refer to [ACC-3, "ACCELERATOR CONTROL SYSTEM"](#) .

DTC P2127, P2128 APP SENSOR

DTC P2127, P2128 APP SENSOR

PF:18002

Component Description

UBS00PEO

The accelerator pedal position sensor is installed on the upper end of the accelerator pedal assembly. The sensor detects the accelerator position and sends a signal to the ECM.

Accelerator pedal position sensor has two sensors. These sensors are a kind of potentiometers which transform the accelerator pedal position into output voltage, and emit the voltage signal to the ECM. In addition, these sensors detect the opening and closing speed of the accelerator pedal and feed the voltage signals to the ECM. The ECM judges the current opening angle of the accelerator pedal from these signals and controls the throttle control motor based on these signals.

Idle position of the accelerator pedal is determined by the ECM receiving the signal from the accelerator pedal position sensor. The ECM uses this signal for the engine operation such as fuel cut.

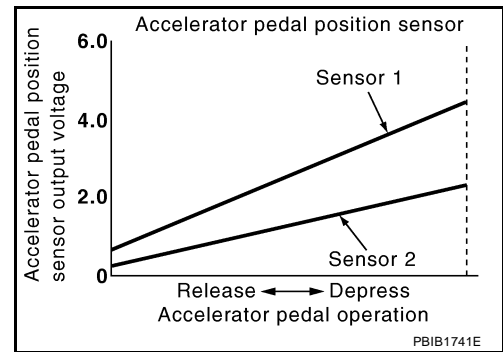

CONSULT-II Reference Value in Data Monitor Mode

UBS00PEP

Specification data are reference values.

MONITOR ITEM	CONDITION		SPECIFICATION
ACCEL SEN 1 ACCEL SEN 2*	● Ignition switch: ON (Engine stopped)	Accelerator pedal: Fully released	0.5 - 1.0V
		Accelerator pedal: Fully depressed	4.2 - 4.8V
CLSD THL POS	● Ignition switch: ON (Engine stopped)	Accelerator pedal: Fully released	ON
		Accelerator pedal: Slightly depressed	OFF

*: Accelerator pedal position sensor 2 signal is converted by ECM internally. Thus, it differ from ECM terminal voltage.

On Board Diagnosis Logic

UBS00PEO

These self-diagnoses have the one trip detection logic.

DTC No.	Trouble diagnosis name	DTC detecting condition	Possible cause
P2127 2127	Accelerator pedal position sensor 2 circuit low input	An excessively low voltage from the APP sensor 2 is sent to ECM.	<ul style="list-style-type: none"> ● Harness or connectors (APP sensor 2 circuit is open or shorted.) (TP sensor circuit is shorted.) ● Accelerator pedal position sensor (APP sensor 2) ● Electric throttle control actuator (TP sensor 1 and 2)
P2128 2128	Accelerator pedal position sensor 2 circuit high input	An excessively high voltage from the APP sensor 2 is sent to ECM.	

FAIL-SAFE MODE

When the malfunction is detected, ECM enters fail-safe mode and the MIL lights up.

Engine operating condition in fail-safe mode

The ECM controls the electric throttle control actuator in regulating the throttle opening in order for the idle position to be within +10 degrees.

The ECM regulates the opening speed of the throttle valve to be slower than the normal condition.

So, the acceleration will be poor.

DTC P2127, P2128 APP SENSOR

UBS00PER

DTC Confirmation Procedure

NOTE:

If DTC Confirmation Procedure has been previously conducted, always turn ignition switch OFF and wait at least 10 seconds before conducting the next test.

TESTING CONDITION:

Before performing the following procedure, confirm that battery voltage is more than 10V at idle.

WITH CONSULT-II

1. Turn ignition switch ON.
2. Select "DATA MONITOR" mode with CONSULT-II.
3. Start engine and let it idle for 1 second.
4. If DTC is detected, go to [EC-628, "Diagnostic Procedure"](#) .

DATA MONITOR	
MONITOR	NO DTC
ENG SPEED	XXX rpm

SEF058Y

WITH GST

Follow the procedure "WITH CONSULT-II" above.

A

EC

C

D

E

F

G

H

I

J

K

L

M

DTC P2127, P2128 APP SENSOR

UBS00PES

Wiring Diagram

EC-APPS2-01

: DETECTABLE LINE FOR DTC
 : NON-DETECTABLE LINE FOR DTC

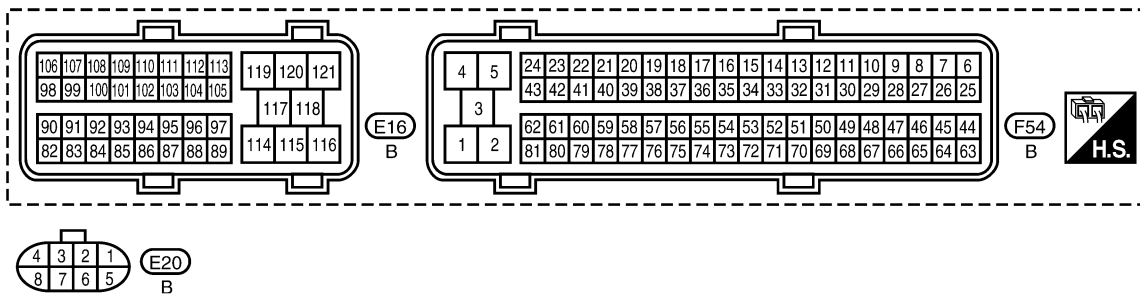
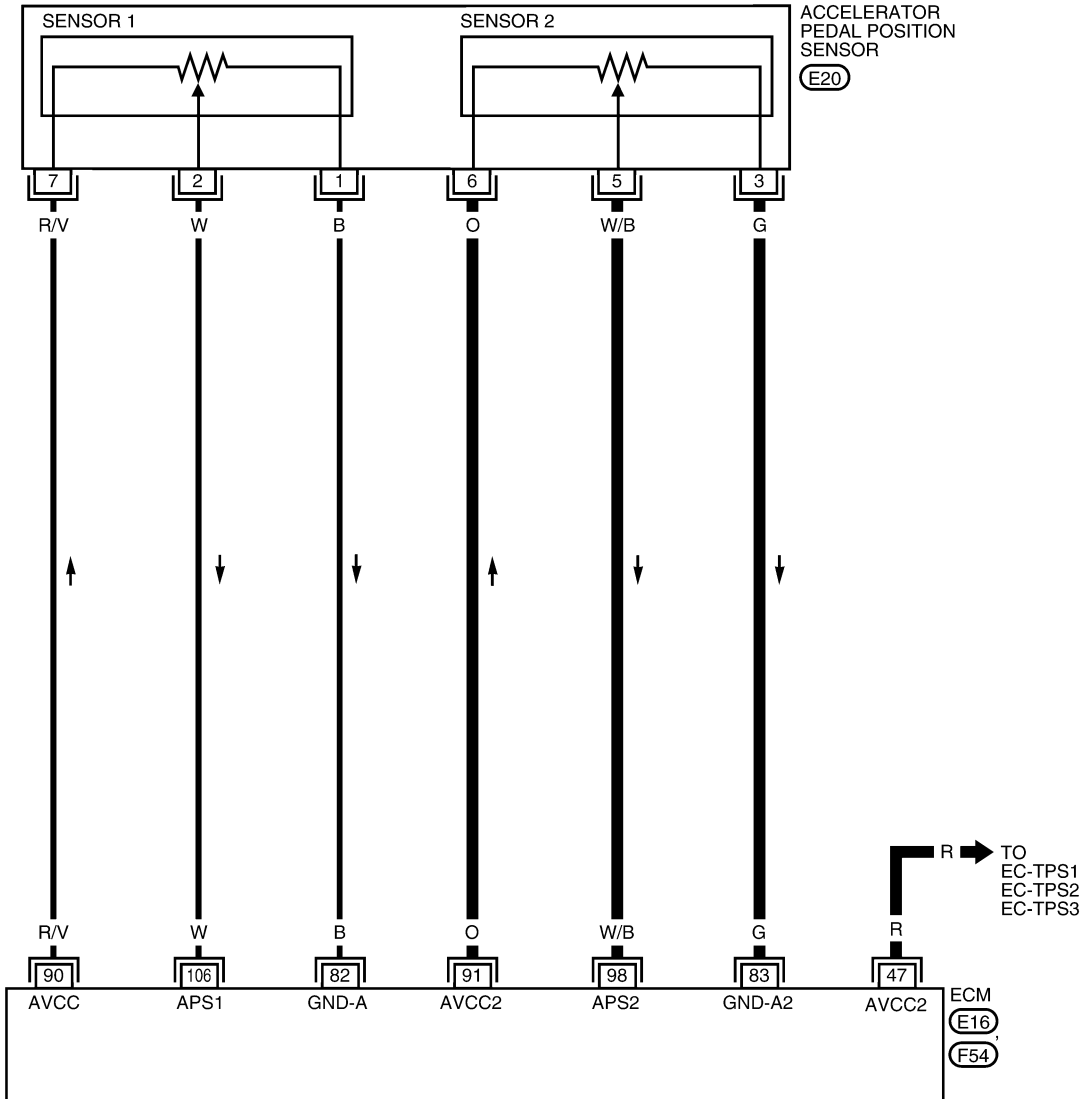

BBWA1639E

DTC P2127, P2128 APP SENSOR

Specification data are reference values and are measured between each terminal and ground.

CAUTION:

Do not use ECM ground terminals when measuring input/output voltage. Doing so may result in damage to the ECM's transistor. Use a ground other than ECM terminals, such as the ground.

TER-MINAL NO.	WIRE COLOR	ITEM	CONDITION	DATA (DC Voltage)
47	R	Throttle position sensor power supply	[Ignition switch: ON]	Approximately 5V
82	B	APP sensor 1 ground	[Engine is running] ● Warm-up condition ● Idle speed	Approximately 0V
83	G	APP sensor 2 ground	[Engine is running] ● Warm-up condition ● Idle speed	Approximately 0V
90	R/V	APP sensor 1 power supply	[Ignition switch: ON]	Approximately 5V
91	O	APP sensor 2 power supply	[Ignition switch: ON]	Approximately 5V
98	W/B	Accelerator pedal position sensor 2	[Ignition switch: ON] ● Engine stopped ● Accelerator pedal: Fully released	0.25 - 0.5V
			[Ignition switch: ON] ● Engine stopped ● Accelerator pedal: Fully depressed	0.2 - 2.5V
106	W	Accelerator pedal position sensor 1	[Ignition switch: ON] ● Engine stopped ● Accelerator pedal: Fully released	0.5 - 1.0V
			[Ignition switch: ON] ● Engine stopped ● Accelerator pedal: Fully depressed	4.2 - 4.8V

A
EC
C
D
E
F
G
H
I
J
K
L
M

DTC P2127, P2128 APP SENSOR

UBS00PET

Diagnostic Procedure

1. CHECK GROUND CONNECTIONS

1. Turn ignition switch OFF.
2. Loosen and retighten three ground screws on the body. Refer to [EC-158, "Ground Inspection"](#).

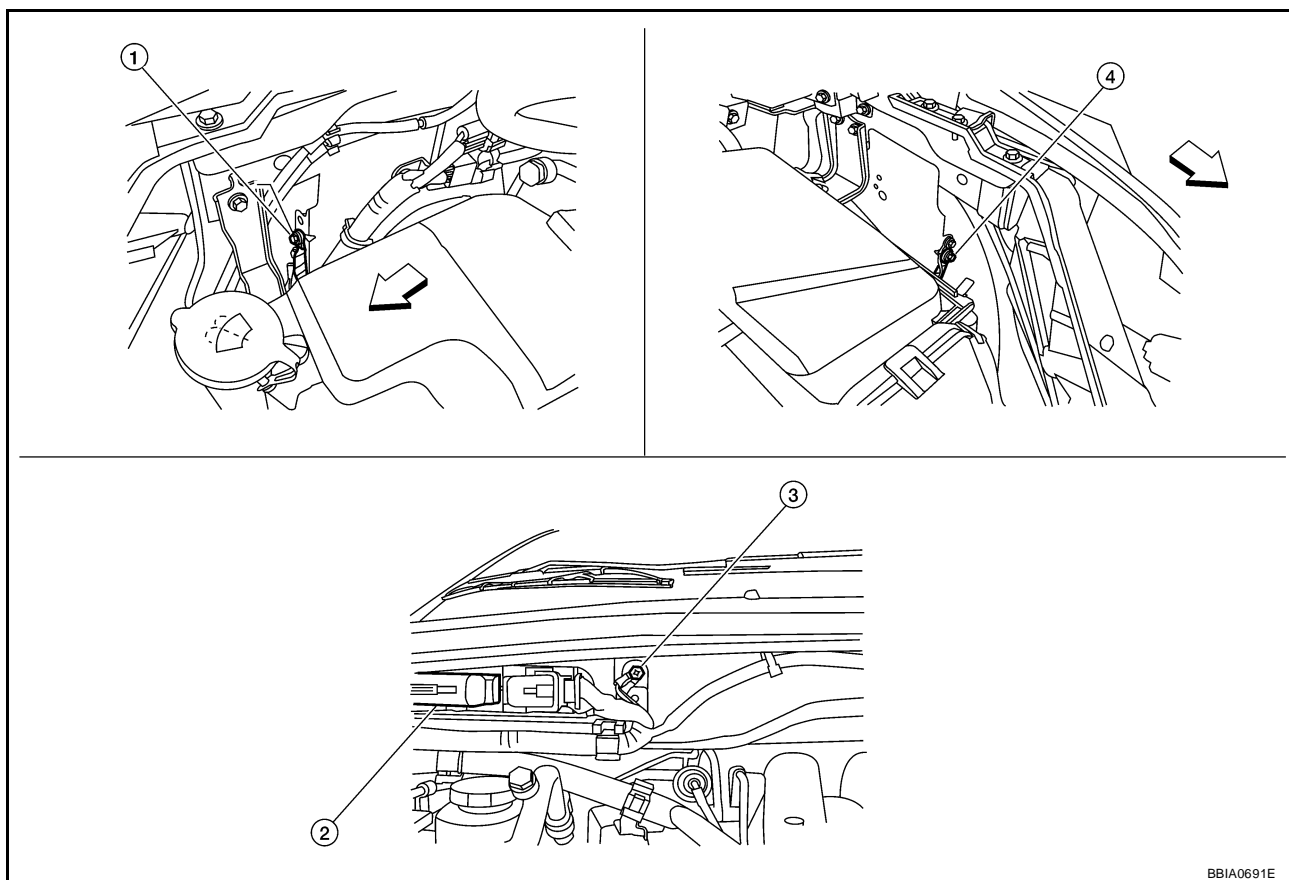

BBA0691E

← Vehicle front

1. Body ground E24

2. ECM

3. Body ground E9

4. Body ground E15

OK or NG

OK >> GO TO 2.

NG >> Repair or replace ground connections.

DTC P2127, P2128 APP SENSOR

2. CHECK APP SENSOR 2 POWER SUPPLY CIRCUIT-I

1. Disconnect accelerator pedal position (APP) sensor harness connector.
2. Turn ignition switch ON.

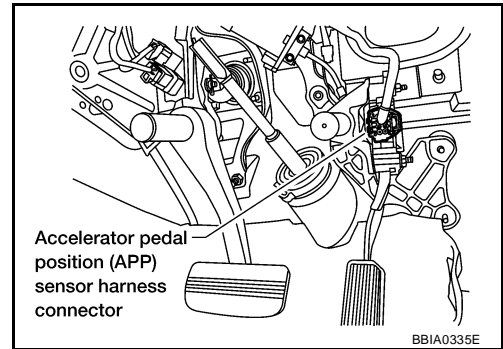

3. Check voltage between APP sensor terminal 6 and ground with CONSULT-II or tester.

Voltage: Approximately 5V

OK or NG

- OK >> GO TO 7.
 NG >> GO TO 3.

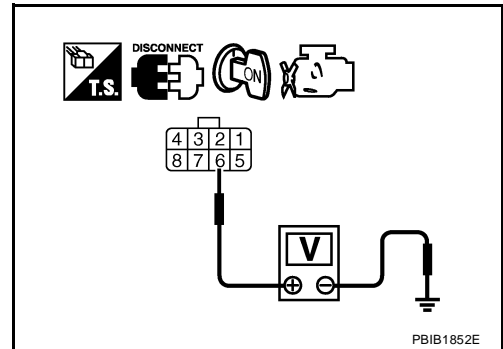

3. CHECK APP SENSOR 2 POWER SUPPLY CIRCUIT-II

1. Turn ignition switch OFF.
2. Disconnect ECM harness connector.
3. Check harness continuity between APP sensor terminal 6 and ECM terminal 91. Refer to wiring diagram.

Continuity should exist.

OK or NG

- OK >> GO TO 4.
 NG >> Repair open circuit.

4. CHECK APP SENSOR 2 POWER SUPPLY CIRCUIT-III

Check harness for short to power and short to ground, between the following terminals.

ECM terminal	Sensor terminal	Reference Wiring Diagram
91	APP sensor terminal 6	EC-626
47	Electric throttle control actuator terminal 1	EC-634

OK or NG

- OK >> GO TO 5.
 NG >> Repair short to ground or short to power in harness or connectors.

5. CHECK THROTTLE POSITION SENSOR

Refer to [EC-639, "Component Inspection"](#) .

OK or NG

- OK >> GO TO 11.
 NG >> GO TO 6.

DTC P2127, P2128 APP SENSOR

6. REPLACE ELECTRIC THROTTLE CONTROL ACTUATOR

1. Replace electric throttle control actuator.
2. Perform [EC-80, "Throttle Valve Closed Position Learning"](#) .
3. Perform [EC-80, "Idle Air Volume Learning"](#) .

>> INSPECTION END

7. CHECK APP SENSOR 2 GROUND CIRCUIT FOR OPEN AND SHORT

1. Turn ignition switch OFF.
2. Disconnect ECM harness connector.
3. Check harness continuity between ECM terminal 83 and APP sensor terminal 3.
Refer to Wiring Diagram.

Continuity should exist.

4. Also check harness for short to ground and short to power.

OK or NG

OK >> GO TO 8.

NG >> Repair open circuit or short to ground or short to power in harness or connectors.

8. CHECK APP SENSOR 2 INPUT SIGNAL CIRCUIT FOR OPEN AND SHORT

1. Check harness continuity between ECM terminal 98 and APP sensor terminal 5.
Refer to Wiring Diagram.

Continuity should exist.

2. Also check harness for short to ground and short to power.

OK or NG

OK >> GO TO 9.

NG >> Repair open circuit or short to ground or short to power in harness or connectors.

9. CHECK APP SENSOR

Refer to [EC-631, "Component Inspection"](#) .

OK or NG

OK >> GO TO 11.

NG >> GO TO 10.

10. REPLACE ACCELERATOR PEDAL ASSEMBLY

1. Replace accelerator pedal assembly.
2. Perform [EC-80, "Accelerator Pedal Released Position Learning"](#) .
3. Perform [EC-80, "Throttle Valve Closed Position Learning"](#) .
4. Perform [EC-80, "Idle Air Volume Learning"](#) .

>> INSPECTION END

11. CHECK INTERMITTENT INCIDENT

Refer to [EC-149, "TROUBLE DIAGNOSIS FOR INTERMITTENT INCIDENT"](#) .

>> INSPECTION END

DTC P2127, P2128 APP SENSOR

UBS00PEU

Component Inspection

ACCELERATOR PEDAL POSITION SENSOR

1. Reconnect all harness connectors disconnected.
2. Turn ignition switch ON.
3. Check voltage between ECM terminals 106 (APP sensor 1 signal), 98 (APP sensor 2 signal) and ground under the following conditions.

Terminal	Accelerator pedal	Voltage
106 (Accelerator pedal position sensor 1)	Fully released	0.5 - 1.0V
	Fully depressed	4.2 - 4.8V
98 (Accelerator pedal position sensor 2)	Fully released	0.25 - 0.5V
	Fully depressed	0.2 - 2.5V

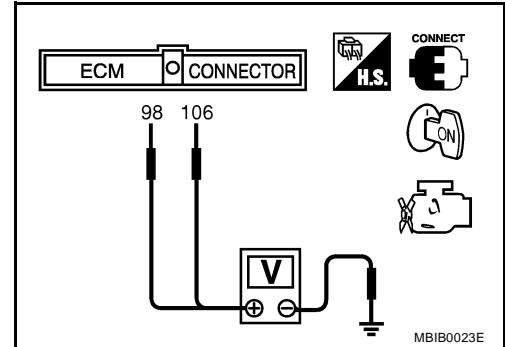

4. If NG, replace accelerator pedal assembly and go to next step.
5. Perform [EC-80, "Accelerator Pedal Released Position Learning"](#).
6. Perform [EC-80, "Throttle Valve Closed Position Learning"](#).
7. Perform [EC-80, "Idle Air Volume Learning"](#).

Removal and Installation

ACCELERATOR PEDAL

Refer to [ACC-3, "ACCELERATOR CONTROL SYSTEM"](#).

UBS00PEV

DTC P2135 TP SENSOR

PF1:16119

DTC P2135 TP SENSOR

Component Description

UBS00PEW

Electric throttle control actuator consists of throttle control motor, throttle position sensor, etc. The throttle position sensor responds to the throttle valve movement.

The throttle position sensor has the two sensors. These sensors are a kind of potentiometers which transform the throttle valve position into output voltage, and emit the voltage signal to the ECM. In addition, these sensors detect the opening and closing speed of the throttle valve and feed the voltage signals to the ECM. The ECM judges the current opening angle of the throttle valve from these signals and the ECM controls the throttle control motor to make the throttle valve opening angle properly in response to driving condition.

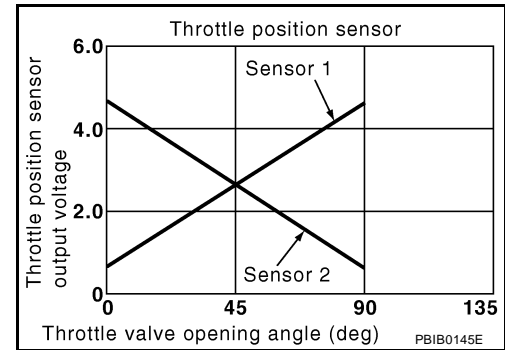

CONSULT-II Reference Value in Data Monitor Mode

UBS00PEX

Specification data are reference values.

MONITOR ITEM	CONDITION		SPECIFICATION
THRTL SEN 1 THRTL SEN 2*	<ul style="list-style-type: none"> Ignition switch: ON (Engine stopped) Shift lever: D 	Accelerator pedal: Fully released	More than 0.36V
		Accelerator pedal: Fully depressed	Less than 4.75V

*: Throttle position sensor 2 signal is converted by ECM internally. Thus, it differs from ECM terminal voltage signal.

On Board Diagnosis Logic

UBS00PEY

This self-diagnosis has the one trip detection logic.

DTC No.	Trouble diagnosis name	DTC detecting condition	Possible cause
P2135 2135	Throttle position sensor circuit range/performance	Rationally incorrect voltage is sent to ECM compared with the signals from TP sensor 1 and TP sensor 2.	<ul style="list-style-type: none"> Harness or connector (TP sensor 1 and 2 circuit is open or shorted.) (APP sensor 2 circuit is shorted.) Electric throttle control actuator (TP sensor 1 and 2) Accelerator pedal position sensor (APP sensor 2)

FAIL-SAFE MODE

When the malfunction is detected, the ECM enters fail-safe mode and the MIL lights up.

Engine operation condition in fail-safe mode

The ECM controls the electric throttle control actuator in regulating the throttle opening in order for the idle position to be within +10 degrees.

The ECM regulates the opening speed of the throttle valve to be slower than the normal condition.

So, the acceleration will be poor.

DTC P2135 TP SENSOR

UBS00PEZ

DTC Confirmation Procedure

NOTE:

If DTC Confirmation Procedure has been previously conducted, always turn ignition switch OFF and wait at least 10 seconds before conducting the next test.

TESTING CONDITION:

Before performing the following procedure, confirm that battery voltage is more than 10V at idle.

WITH CONSULT-II

1. Turn ignition switch ON.
2. Select "DATA MONITOR" mode with CONSULT-II.
3. Start engine and let it idle for 1 second.
4. If DTC is detected, go to [EC-636, "Diagnostic Procedure"](#) .

DATA MONITOR	
MONITOR	NO DTC
ENG SPEED	XXX rpm

SEF058Y

WITH GST

Follow the procedure "WITH CONSULT-II" above.

A
EC
C
D
E
F
G
H
I
J
K
L
M

DTC P2135 TP SENSOR

UBS00PF0

Wiring Diagram

EC-TPS3-01

: DETECTABLE LINE FOR DTC
 : NON-DETECTABLE LINE FOR DTC

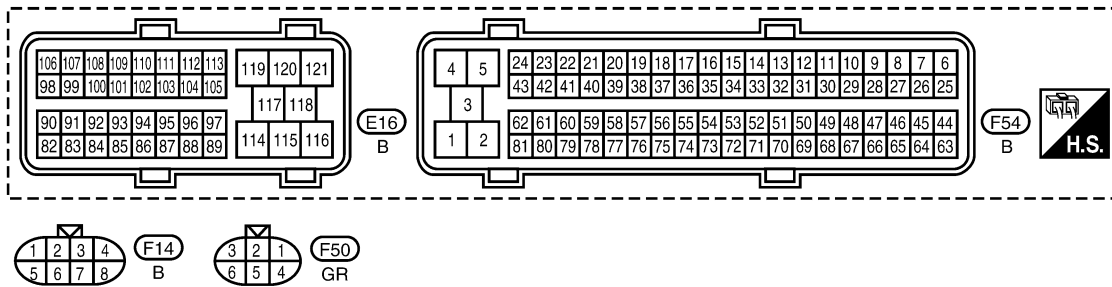
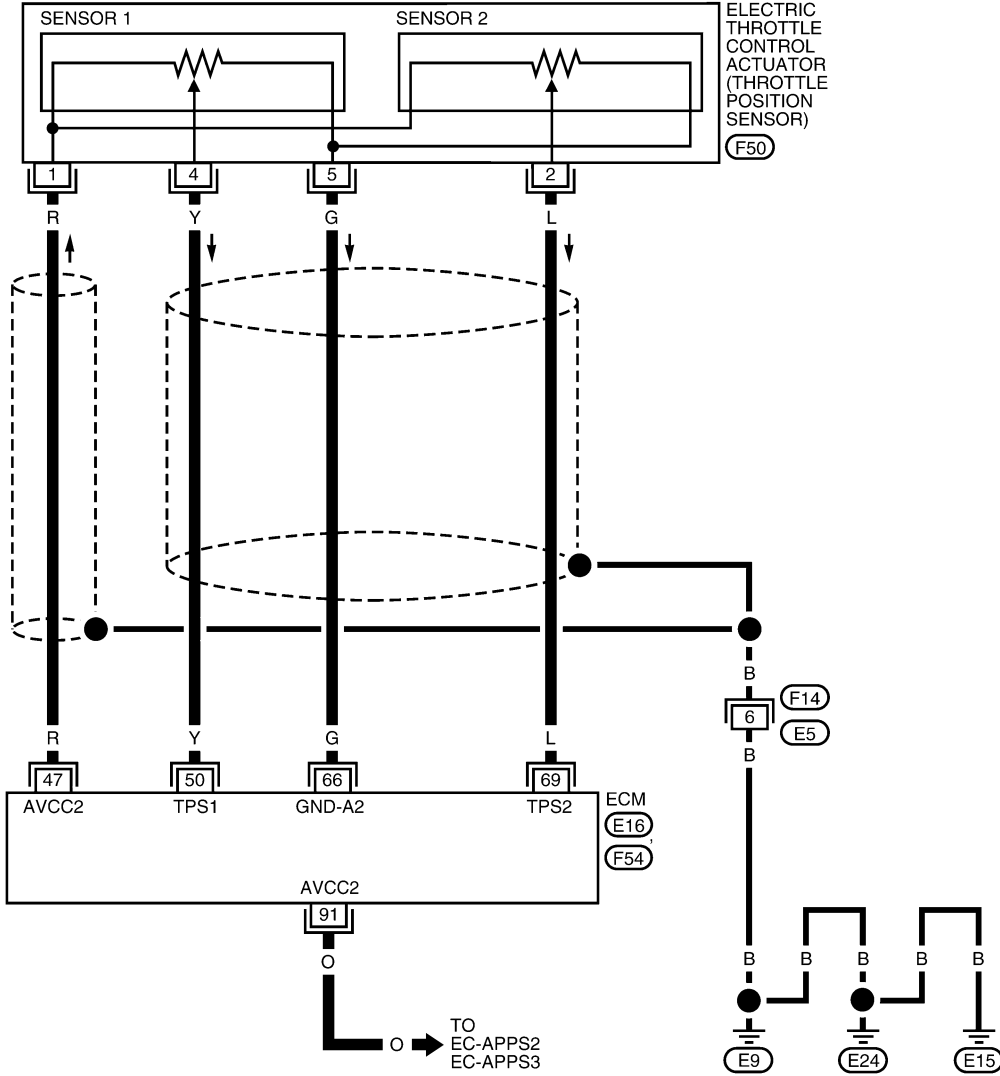

BBWA1640E

DTC P2135 TP SENSOR

Specification data are reference values and are measured between each terminal and ground.

CAUTION:

Do not use ECM ground terminals when measuring input/output voltage. Doing so may result in damage to the ECM's transistor. Use a ground other than ECM terminals, such as the ground.

TER-MINAL NO.	WIRE COLOR	ITEM	CONDITION	DATA (DC Voltage)
47	R	Throttle position sensor power supply	[Ignition switch: ON]	Approximately 5V
50	Y	Throttle position sensor 1	[Ignition switch: ON] <ul style="list-style-type: none"> ● Engine stopped ● Shift lever: D ● Accelerator pedal: Fully released 	More than 0.36V
			[Ignition switch: ON] <ul style="list-style-type: none"> ● Engine stopped ● Shift lever: D ● Accelerator pedal: Fully depressed 	Less than 4.75V
66	G	Throttle position sensor ground	[Engine is running] <ul style="list-style-type: none"> ● Warm-up condition ● Idle speed 	Approximately 0V
69	L	Throttle position sensor 2	[Ignition switch: ON] <ul style="list-style-type: none"> ● Engine stopped ● Shift lever: D ● Accelerator pedal: Fully released 	Less than 4.75V
			[Ignition switch: ON] <ul style="list-style-type: none"> ● Engine stopped ● Shift lever: D ● Accelerator pedal: Fully depressed 	More than 0.36V
91	O	APP sensor 2 power supply	[Ignition switch: ON]	Approximately 5V

A
EC
C
D
E
F
G
H
I
J
K
L
M

DTC P2135 TP SENSOR

UBS00PF1

Diagnostic Procedure

1. CHECK GROUND CONNECTIONS

1. Turn ignition switch OFF.
2. Loosen and retighten three ground screws on the body. Refer to [EC-158, "Ground Inspection"](#).

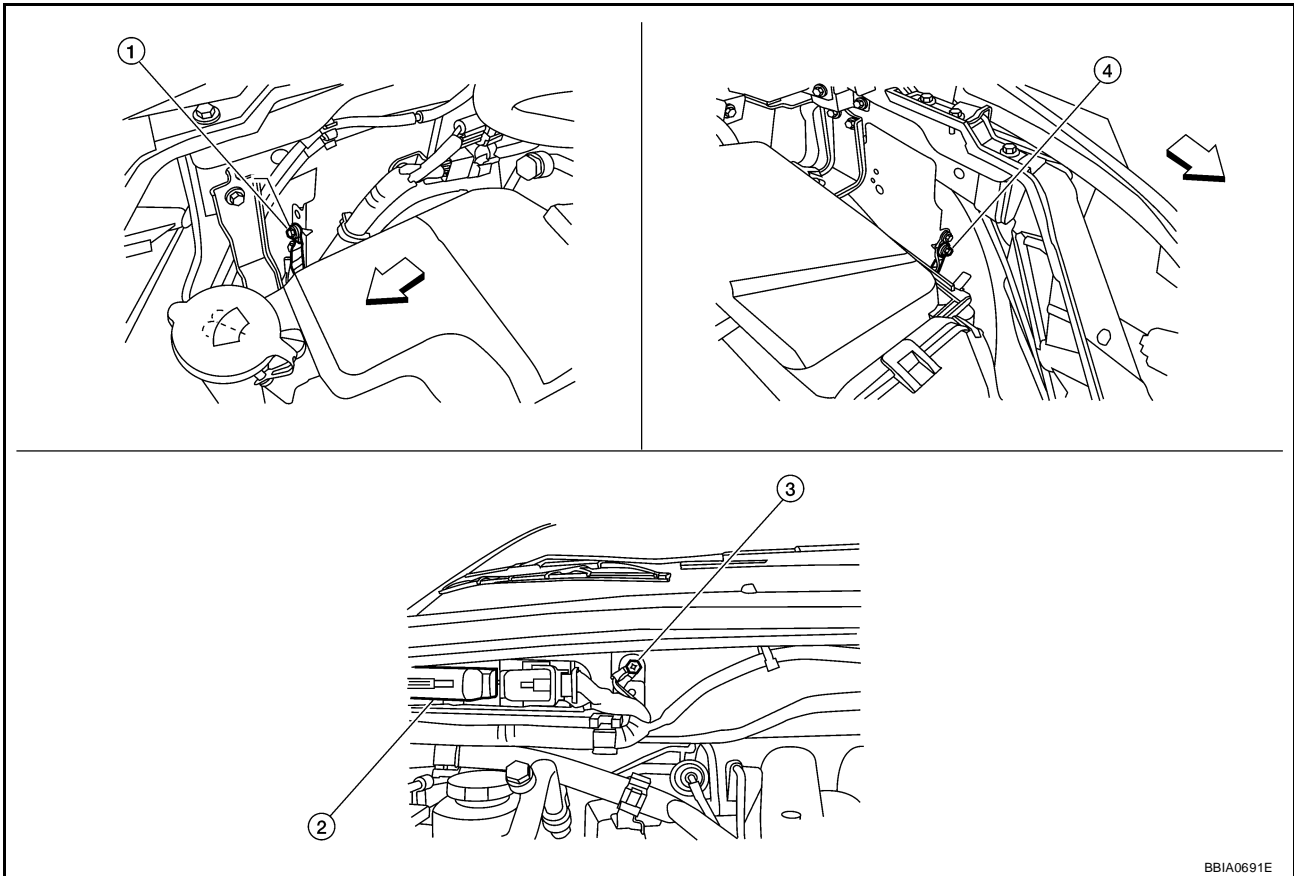

B8IA0691E

← Vehicle front

1. Body ground E24

2. ECM

3. Body ground E9

4. Body ground E15

OK or NG

OK >> GO TO 2.

NG >> Repair or replace ground connections.

DTC P2135 TP SENSOR

2. CHECK THROTTLE POSITION SENSOR POWER SUPPLY CIRCUIT-I

1. Disconnect electric throttle control actuator harness connector.
2. Turn ignition switch ON.

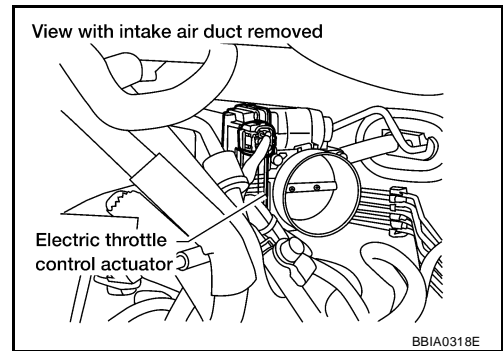

3. Check voltage between electric throttle control actuator terminal 1 and ground with CONSULT-II or tester.

Voltage: Approximately 5V

OK or NG

- OK >> GO TO 7.
NG >> GO TO 3.

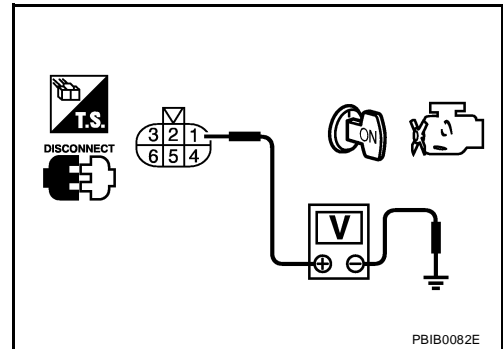

3. CHECK THROTTLE POSITION SENSOR POWER SUPPLY CIRCUIT-II

1. Turn ignition switch OFF.
2. Disconnect ECM harness connector.
3. Check harness continuity between electric throttle control actuator terminal 1 and ECM terminal 47. Refer to Wiring Diagram.

Continuity should exist.

OK or NG

- OK >> GO TO 4.
NG >> Repair open circuit.

4. CHECK THROTTLE POSITION SENSOR POWER SUPPLY CIRCUIT-III

Check harness for short to power and short to ground, between the following terminals.

ECM terminal	Sensor terminal	Reference Wiring Diagram
47	Electric throttle control actuator terminal 1	EC-634
91	APP sensor terminal 6	EC-642

OK or NG

- OK >> GO TO 5.
NG >> Repair short to ground or short to power in harness or connectors.

5. CHECK APP SENSOR

Refer to [EC-647, "Component Inspection"](#) .

OK or NG

- OK >> GO TO 11.
NG >> GO TO 6.

DTC P2135 TP SENSOR

6. REPLACE ACCELERATOR PEDAL ASSEMBLY

1. Replace accelerator pedal assembly.
2. Perform [EC-80, "Accelerator Pedal Released Position Learning"](#) .
3. Perform [EC-80, "Throttle Valve Closed Position Learning"](#) .
4. Perform [EC-80, "Idle Air Volume Learning"](#) .

>> INSPECTION END

7. CHECK THROTTLE POSITION SENSOR GROUND CIRCUIT FOR OPEN AND SHORT

1. Turn ignition switch OFF.
2. Disconnect ECM harness connector.
3. Check harness continuity between ECM terminal 66 and electric throttle control actuator terminal 5.
Refer to Wiring Diagram.

Continuity should exist.

4. Also check harness for short to ground and short to power.

OK or NG

OK >> GO TO 8.

NG >> Repair open circuit or short to ground or short to power in harness or connectors.

8. CHECK THROTTLE POSITION SENSOR INPUT SIGNAL CIRCUIT FOR OPEN AND SHORT

1. Check harness continuity between ECM terminal 50 and electric throttle control actuator terminal 4, ECM terminal 69 and electric throttle control actuator terminal 2.
Refer to Wiring Diagram.

Continuity should exist.

2. Also check harness for short to ground and short to power.

OK or NG

OK >> GO TO 9.

NG >> Repair open circuit or short to ground or short to power in harness or connectors.

9. CHECK THROTTLE POSITION SENSOR

Refer to [EC-639, "Component Inspection"](#) .

OK or NG

OK >> GO TO 11.

NG >> GO TO 10.

10. REPLACE ELECTRIC THROTTLE CONTROL ACTUATOR

1. Replace the electric throttle control actuator.
2. Perform [EC-80, "Throttle Valve Closed Position Learning"](#) .
3. Perform [EC-80, "Idle Air Volume Learning"](#) .

>> INSPECTION END

11. CHECK INTERMITTENT INCIDENT

Refer to [EC-149, "TROUBLE DIAGNOSIS FOR INTERMITTENT INCIDENT"](#) .

>> INSPECTION END

DTC P2135 TP SENSOR

UBS00PF2

Component Inspection THROTTLE POSITION SENSOR

1. Reconnect all harness connectors disconnected.
2. Perform [EC-80, "Throttle Valve Closed Position Learning"](#) .
3. Turn ignition switch ON.
4. Set shift lever to D position.
5. Check voltage between ECM terminals 50 (TP sensor 1 signal), 69 (TP sensor 2 signal) and ground under the following conditions.

Terminal	Accelerator pedal	Voltage
50 (Throttle position sensor 1)	Fully released	More than 0.36V
	Fully depressed	Less than 4.75V
69 (Throttle position sensor 2)	Fully released	Less than 4.75V
	Fully depressed	More than 0.36V

6. If NG, replace electric throttle control actuator and go to the next step.
7. Perform [EC-80, "Throttle Valve Closed Position Learning"](#) .
8. Perform [EC-80, "Idle Air Volume Learning"](#) .

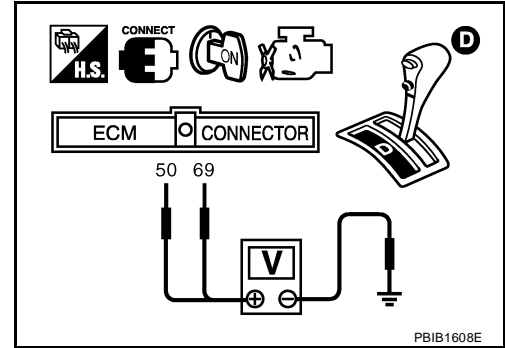

Removal and Installation ELECTRIC THROTTLE CONTROL ACTUATOR

UBS00PF3

Refer to [EM-18, "INTAKE MANIFOLD COLLECTOR"](#) .

DTC P2138 APP SENSOR

DTC P2138 APP SENSOR

PF1:18002

Component Description

UBS00PF4

The accelerator pedal position sensor is installed on the upper end of the accelerator pedal assembly. The sensor detects the accelerator position and sends a signal to the ECM.

Accelerator pedal position sensor has two sensors. These sensors are a kind of potentiometers which transform the accelerator pedal position into output voltage, and emit the voltage signal to the ECM. In addition, these sensors detect the opening and closing speed of the accelerator pedal and feed the voltage signals to the ECM. The ECM judges the current opening angle of the accelerator pedal from these signals and controls the throttle control motor based on these signals.

Idle position of the accelerator pedal is determined by the ECM receiving the signal from the accelerator pedal position sensor. The ECM uses this signal for the engine operation such as fuel cut.

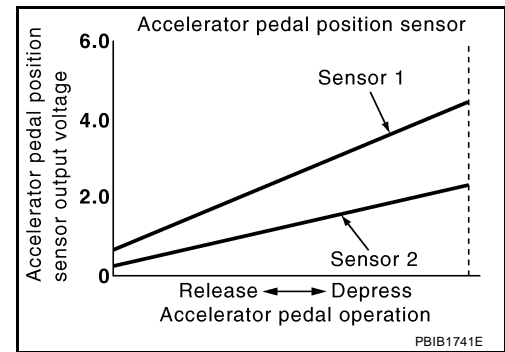

CONSULT-II Reference Value in Data Monitor Mode

UBS00PF5

Specification data are reference values.

MONITOR ITEM	CONDITION		SPECIFICATION
ACCEL SEN 1 ACCEL SEN 2*	● Ignition switch: ON (Engine stopped)	Accelerator pedal: Fully released	0.5 - 1.0V
		Accelerator pedal: Fully depressed	4.2 - 4.8V
CLSD THL POS	● Ignition switch: ON (Engine stopped)	Accelerator pedal: Fully released	ON
		Accelerator pedal: Slightly depressed	OFF

*: Accelerator pedal position sensor 2 signal is converted by ECM internally. Thus, it differs from ECM terminal voltage.

On Board Diagnosis Logic

UBS00PF6

This self-diagnosis has the one trip detection logic.

NOTE:

If DTC P2138 is displayed with DTC P0643, first perform the trouble diagnosis for DTC P0643. Refer to [EC-529, "DTC P0643 SENSOR POWER SUPPLY"](#).

DTC No.	Trouble diagnosis name	DTC detecting condition	Possible cause
P2138 2138	Accelerator pedal position sensor circuit range/performance	Rationally incorrect voltage is sent to ECM compared with the signals from APP sensor 1 and APP sensor 2.	<ul style="list-style-type: none"> ● Harness or connector (APP sensor 1 and 2 circuit is open or shorted.) (TP sensor circuit is shorted.) ● Accelerator pedal position sensor (APP sensor 1 and 2) ● Electric throttle control actuator (TP sensor 1 and 2)

FAIL-SAFE MODE

When the malfunction is detected, ECM enters fail-safe mode and the MIL lights up.

Engine operating condition in fail-safe mode

The ECM controls the electric throttle control actuator in regulating the throttle opening in order for the idle position to be within +10 degrees.

The ECM regulates the opening speed of the throttle valve to be slower than the normal condition.

So, the acceleration will be poor.

DTC P2138 APP SENSOR

UBS00PF7

DTC Confirmation Procedure

NOTE:

If DTC Confirmation Procedure has been previously conducted, always turn ignition switch OFF and wait at least 10 seconds before conducting the next test.

TESTING CONDITION:

Before performing the following procedure, confirm that battery voltage is more than 10V at idle.

WITH CONSULT-II

1. Turn ignition switch ON.
2. Select "DATA MONITOR" mode with CONSULT-II.
3. Start engine and let it idle for 1 second.
4. If DTC is detected, go to [EC-644, "Diagnostic Procedure"](#) .

DATA MONITOR	
MONITOR	NO DTC
ENG SPEED	XXX rpm

SEF058Y

WITH GST

Follow the procedure "WITH CONSULT-II" above.

A
EC
C
D
E
F
G
H
I
J
K
L
M

DTC P2138 APP SENSOR

UBS00PF8

Wiring Diagram

EC-APPS3-01

: DETECTABLE LINE FOR DTC
 : NON-DETECTABLE LINE FOR DTC

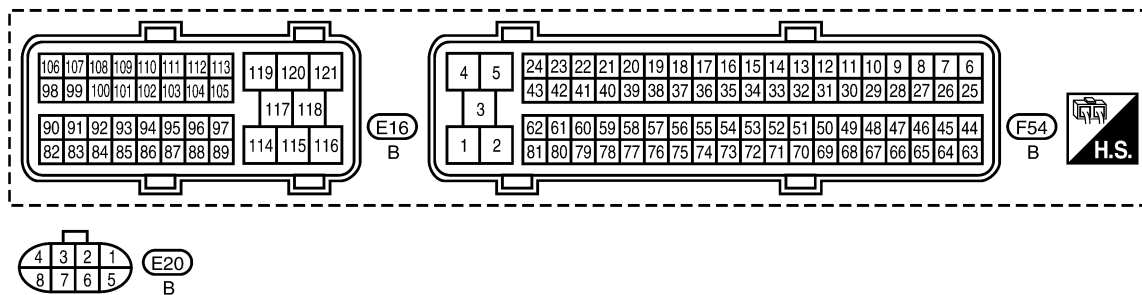
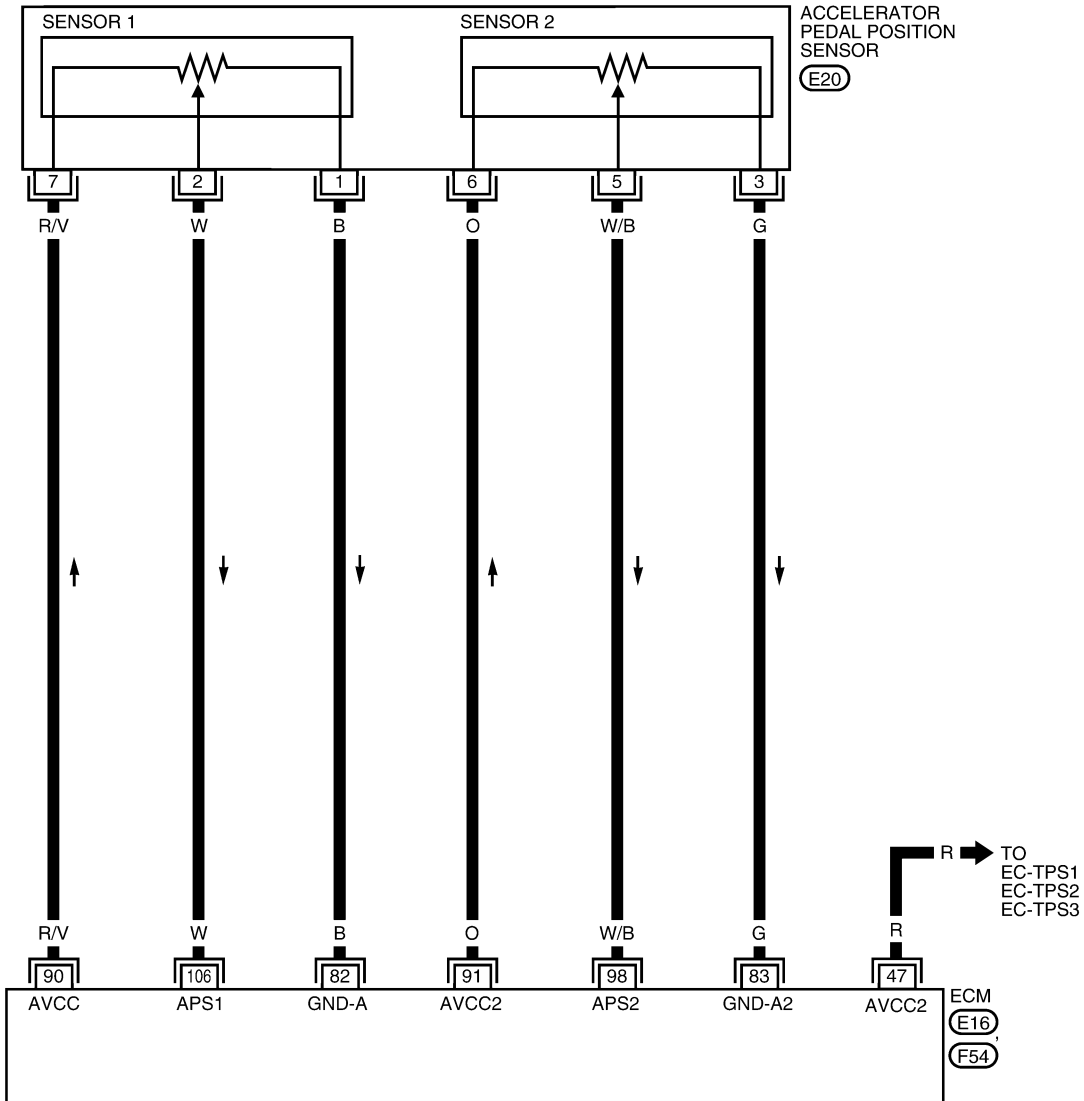

BBWA1641E

DTC P2138 APP SENSOR

Specification data are reference values and are measured between each terminal and ground.

CAUTION:

Do not use ECM ground terminals when measuring input/output voltage. Doing so may result in damage to the ECM's transistor. Use a ground other than ECM terminals, such as the ground.

TER-MINAL NO.	WIRE COLOR	ITEM	CONDITION	DATA (DC Voltage)
47	R	Throttle position sensor power supply	[Ignition switch: ON]	Approximately 5V
82	B	APP sensor 1 ground	[Engine is running] ● Warm-up condition ● Idle speed	Approximately 0V
83	G	APP sensor 2 ground	[Engine is running] ● Warm-up condition ● Idle speed	Approximately 0V
90	R/V	APP sensor 1 power supply	[Ignition switch: ON]	Approximately 5V
91	O	APP sensor 2 power supply	[Ignition switch: ON]	Approximately 5V
98	W/B	Accelerator pedal position sensor 2	[Ignition switch: ON] ● Engine stopped ● Accelerator pedal: Fully released	0.25 - 0.5V
			[Ignition switch: ON] ● Engine stopped ● Accelerator pedal: Fully depressed	0.2 - 2.5V
106	W	Accelerator pedal position sensor 1	[Ignition switch: ON] ● Engine stopped ● Accelerator pedal: Fully released	0.5 - 1.0V
			[Ignition switch: ON] ● Engine stopped ● Accelerator pedal: Fully depressed	4.2 - 4.8V

A

EC

C

D

E

F

G

H

I

J

K

L

M

DTC P2138 APP SENSOR

UBS00PF9

Diagnostic Procedure

1. CHECK GROUND CONNECTIONS

1. Turn ignition switch OFF.
2. Loosen and retighten three ground screws on the body. Refer to [EC-158, "Ground Inspection"](#).

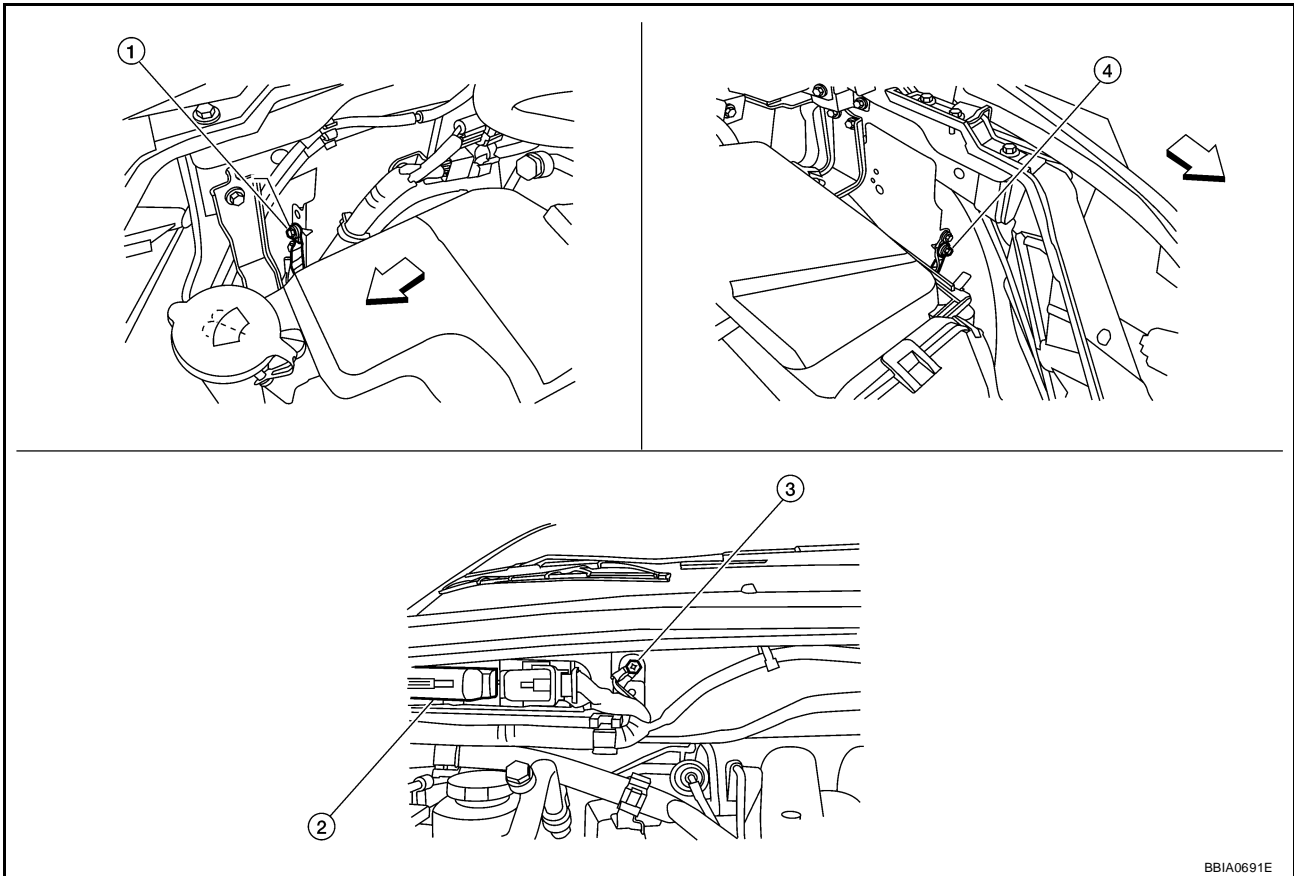

BBA0691E

← Vehicle front

1. Body ground E24

2. ECM

3. Body ground E9

4. Body ground E15

OK or NG

OK >> GO TO 2.

NG >> Repair or replace ground connections.

DTC P2138 APP SENSOR

2. CHECK APP SENSOR 1 POWER SUPPLY CIRCUIT

1. Disconnect accelerator pedal position (APP) sensor harness connector.
2. Turn ignition switch ON.

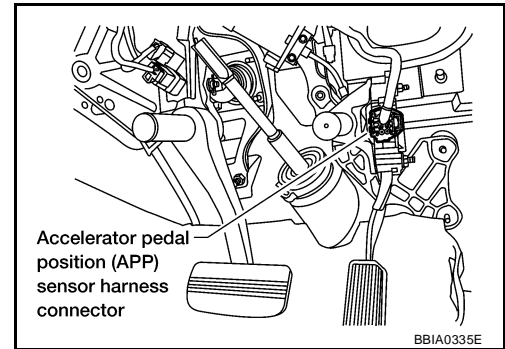

3. Check voltage between APP sensor terminals 7 and ground with CONSULT-II or tester.

Voltage: Approximately 5V

OK or NG

OK >> GO TO 3.

NG >> Repair open circuit or short to ground or short to power in harness or connectors.

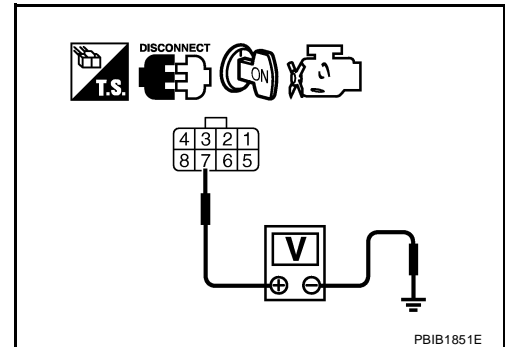

3. CHECK APP SENSOR 2 POWER SUPPLY CIRCUIT-I

Check voltage between APP sensor terminal 6 and ground with CONSULT-II or tester.

Voltage: Approximately 5V

OK or NG

OK >> GO TO 8.

NG >> GO TO 4.

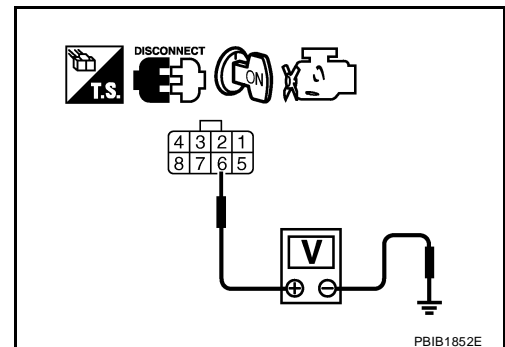

4. CHECK APP SENSOR 2 POWER SUPPLY CIRCUIT-II

1. Turn ignition switch OFF.
2. Disconnect ECM harness connector.
3. Check harness continuity between APP sensor terminal 6 and ECM terminal 91. Refer to wiring diagram.

Continuity should exist.

OK or NG

OK >> GO TO 5.

NG >> Repair open circuit.

DTC P2138 APP SENSOR

5. CHECK APP SENSOR 2 POWER SUPPLY CIRCUIT-III

Check harness for short to power and short to ground, between the following terminals.

ECM terminal	Sensor terminal	Reference Wiring Diagram
91	APP sensor terminal 6	EC-642
47	Electric throttle control actuator terminal 1	EC-634

OK or NG

- OK >> GO TO 6.
- NG >> Repair short to ground or short to power in harness or connectors.

6. CHECK THROTTLE POSITION SENSOR

Refer to [EC-639, "Component Inspection"](#) .

OK or NG

- OK >> GO TO 12.
- NG >> GO TO 7.

7. REPLACE ELECTRIC THROTTLE CONTROL ACTUATOR

1. Replace electric throttle control actuator.
2. Perform [EC-80, "Throttle Valve Closed Position Learning"](#) .
3. Perform [EC-80, "Idle Air Volume Learning"](#) .

>> **INSPECTION END**

8. CHECK APP SENSOR GROUND CIRCUIT FOR OPEN AND SHORT

1. Turn ignition switch OFF.
2. Disconnect ECM harness connector.
3. Check harness continuity between APP sensor terminals 1 and ECM terminal 82, APP sensor terminal 3 and ECM terminal 83.
Refer to Wiring Diagram.

Continuity should exist.

4. Also check harness for short to ground and short to power.

OK or NG

- OK >> GO TO 9.
- NG >> Repair open circuit or short to ground or short to power in harness or connectors.

9. CHECK APP SENSOR INPUT SIGNAL CIRCUIT FOR OPEN AND SHORT

1. Check harness continuity between ECM terminal 106 and APP sensor terminal 2, ECM terminal 98 and APP sensor terminal 5.
Refer to Wiring Diagram.

Continuity should exist.

2. Also check harness for short to ground and short to power.

OK or NG

- OK >> GO TO 10.
- NG >> Repair open circuit or short to ground or short to power in harness or connectors.

DTC P2138 APP SENSOR

10. CHECK APP SENSOR

Refer to [EC-647, "Component Inspection"](#) .

OK or NG

- OK >> GO TO 12.
- NG >> GO TO 11.

11. REPLACE ACCELERATOR PEDAL ASSEMBLY

1. Replace accelerator pedal assembly.
2. Perform [EC-80, "Accelerator Pedal Released Position Learning"](#) .
3. Perform [EC-80, "Throttle Valve Closed Position Learning"](#) .
4. Perform [EC-80, "Idle Air Volume Learning"](#) .

>> INSPECTION END

12. CHECK INTERMITTENT INCIDENT

Refer to [EC-149, "TROUBLE DIAGNOSIS FOR INTERMITTENT INCIDENT"](#) .

>> INSPECTION END

Component Inspection ACCELERATOR PEDAL POSITION SENSOR

UBS00PFA

1. Reconnect all harness connectors disconnected.
2. Turn ignition switch ON.
3. Check voltage between ECM terminals 106 (APP sensor 1 signal), 98 (APP sensor 2 signal) and ground under the following conditions.

Terminal	Accelerator pedal	Voltage
106 (Accelerator pedal position sensor 1)	Fully released	0.5 - 1.0V
	Fully depressed	4.2 - 4.8V
98 (Accelerator pedal position sensor 2)	Fully released	0.25 - 0.5V
	Fully depressed	0.2 - 2.5V

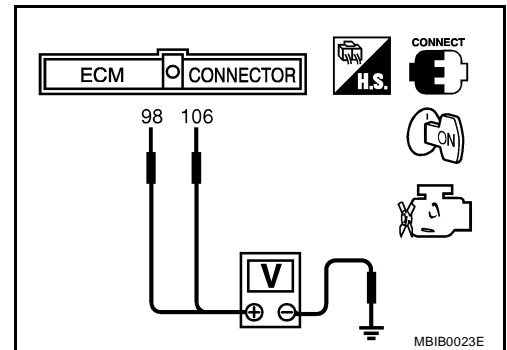

4. If NG, replace accelerator pedal assembly and go to next step.
5. Perform [EC-80, "Accelerator Pedal Released Position Learning"](#) .
6. Perform [EC-80, "Throttle Valve Closed Position Learning"](#) .
7. Perform [EC-80, "Idle Air Volume Learning"](#) .

Removal and Installation ACCELERATOR PEDAL

UBS00PFB

Refer to [ACC-3, "ACCELERATOR CONTROL SYSTEM"](#) .

DTC P2A00, P2A03 A/F SENSOR 1

PF2:22693

DTC P2A00, P2A03 A/F SENSOR 1

Component Description

UBS00PFC

The A/F sensor is a planar dual-cell limit current sensor. The sensor element of the A/F sensor is the combination of a Nernst concentration cell (sensor cell) with an oxygen-pump cell, which transports ions. It has a heater in the element.

The sensor is capable of precise measurement $\lambda = 1$, but also in the lean and rich range. Together with its control electronics, the sensor outputs a clear, continuous signal throughout a wide λ range ($0.7 < \lambda < \text{air}$).

The exhaust gas components diffuse through the diffusion gap at the electrode of the oxygen pump and Nernst concentration cell, where they are brought to thermodynamic balance.

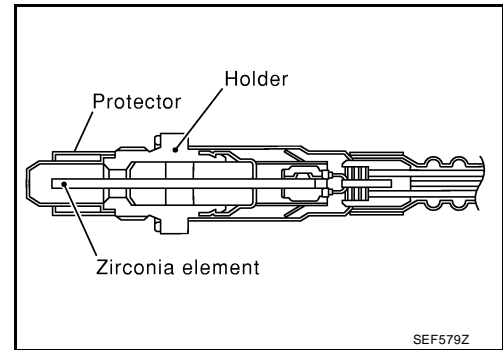

An electronic circuit controls the pump current through the oxygen-pump cell so that the composition of the exhaust gas in the diffusion gap remains constant at $\lambda = 1$. Therefore, the A/F sensor is able to indicate air/fuel ratio by this pumping of current. In addition, a heater is integrated in the sensor to ensure the required operating temperature of 700 - 800°C (1,292 - 1,472°F).

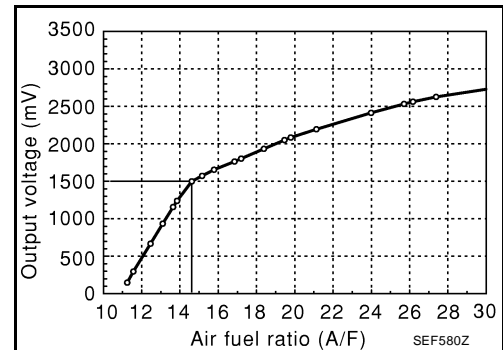

CONSULT-II Reference Value in Data Monitor Mode

UBS00PFE

Specification data are reference values.

MONITOR ITEM	CONDITION	SPECIFICATION
A/F SEN1 (B1) A/F SEN1 (B2)	<ul style="list-style-type: none"> Engine: After warming up Maintaining engine speed at 2,000 rpm	Fluctuates around 1.5V

On Board Diagnosis Logic

UBS00PFE

To judge the malfunction, the A/F signal computed by ECM from the air fuel ratio (A/F) sensor 1 signal is monitored not to be shifted to LEAN side or RICH side.

DTC No.	Trouble diagnosis name	DTC detecting condition	Possible Cause
P2A00 2A00 (Bank 1)	Air fuel ratio (A/F) sensor 1 circuit range/performance	<ul style="list-style-type: none"> The output voltage computed by ECM from the A/F sensor 1 signal is shifted to the lean side for a specified period. 	<ul style="list-style-type: none"> Air fuel ratio (A/F) sensor 1 Air fuel ratio (A/F) sensor 1 heater Fuel pressure Fuel injector Intake air leaks
P2A03 2A03 (Bank 2)		<ul style="list-style-type: none"> The A/F signal computed by ECM from the A/F sensor 1 signal is shifted to the rich side for a specified period. 	

DTC P2A00, P2A03 A/F SENSOR 1

UBS00PFF

DTC Confirmation Procedure

NOTE:

If DTC Confirmation Procedure has been previously conducted, always turn ignition switch OFF and wait at least 10 seconds before conducting the next test.

TESTING CONDITION:

Before performing the following procedure, confirm that battery voltage is more than 11V at idle.

① WITH CONSULT-II

1. Start engine and warm it up to normal operating temperature.
2. Turn ignition switch OFF and wait at least 10 seconds.
3. Turn ignition switch ON and select "SELF-LEARNING CONT" in "WORK SUPPORT" mode with CONSULT-II.
4. Clear the self-learning coefficient by touching "CLEAR".
5. Turn ignition switch OFF and wait at least 10 seconds.
6. Start engine and keep the engine speed between 3,500 and 4,000 rpm for 1 minute under no load.
7. Let engine idle for 1 minute.
8. Keep engine speed between 2,500 and 3,000 rpm for 20 minutes.
9. If 1st trip DTC is detected, go to [EC-654, "Diagnostic Procedure"](#)

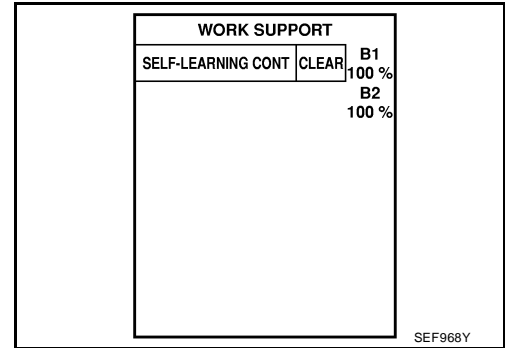

② WITH GST

1. Start engine and warm it up to normal operating temperature.
2. Turn ignition switch OFF and wait at least 10 seconds.
3. Disconnect mass air flow sensor harness connector.
4. Start engine and let it idle for at least 5 seconds.
5. Stop engine and reconnect mass air flow sensor harness connector.
6. Select Service \$03 with GST and make sure that DTC P0102 is detected.
7. Select Service \$04 with GST and erase the DTC P0102.
8. Start engine and keep the engine speed between 3,500 and 4,000 rpm for 1 minute under no load.
9. Let engine idle for 1 minute.
10. Keep engine speed between 2,500 and 3,000 rpm for 20 minutes.
11. Select Service \$07 with GST.
If 1st trip DTC is detected, go to [EC-654, "Diagnostic Procedure"](#).

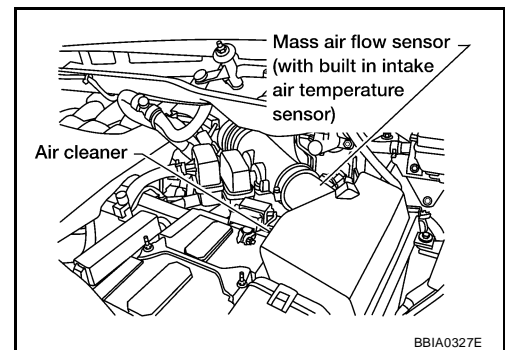

DTC P2A00, P2A03 A/F SENSOR 1

UBS00PFG

Wiring Diagram BANK 1

EC-AF1B1-01

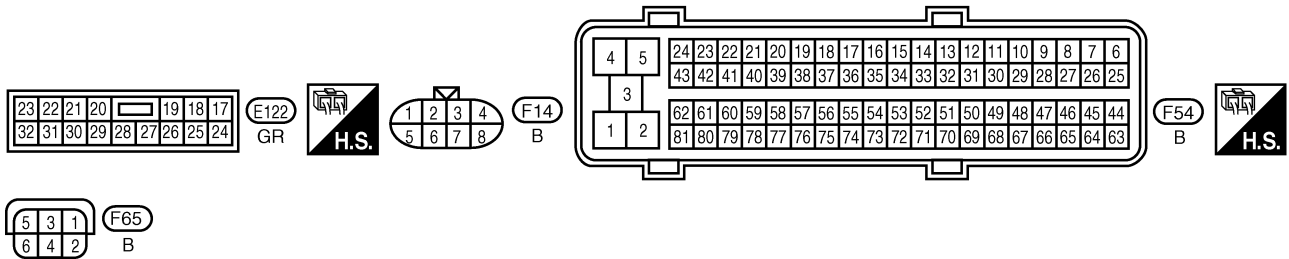
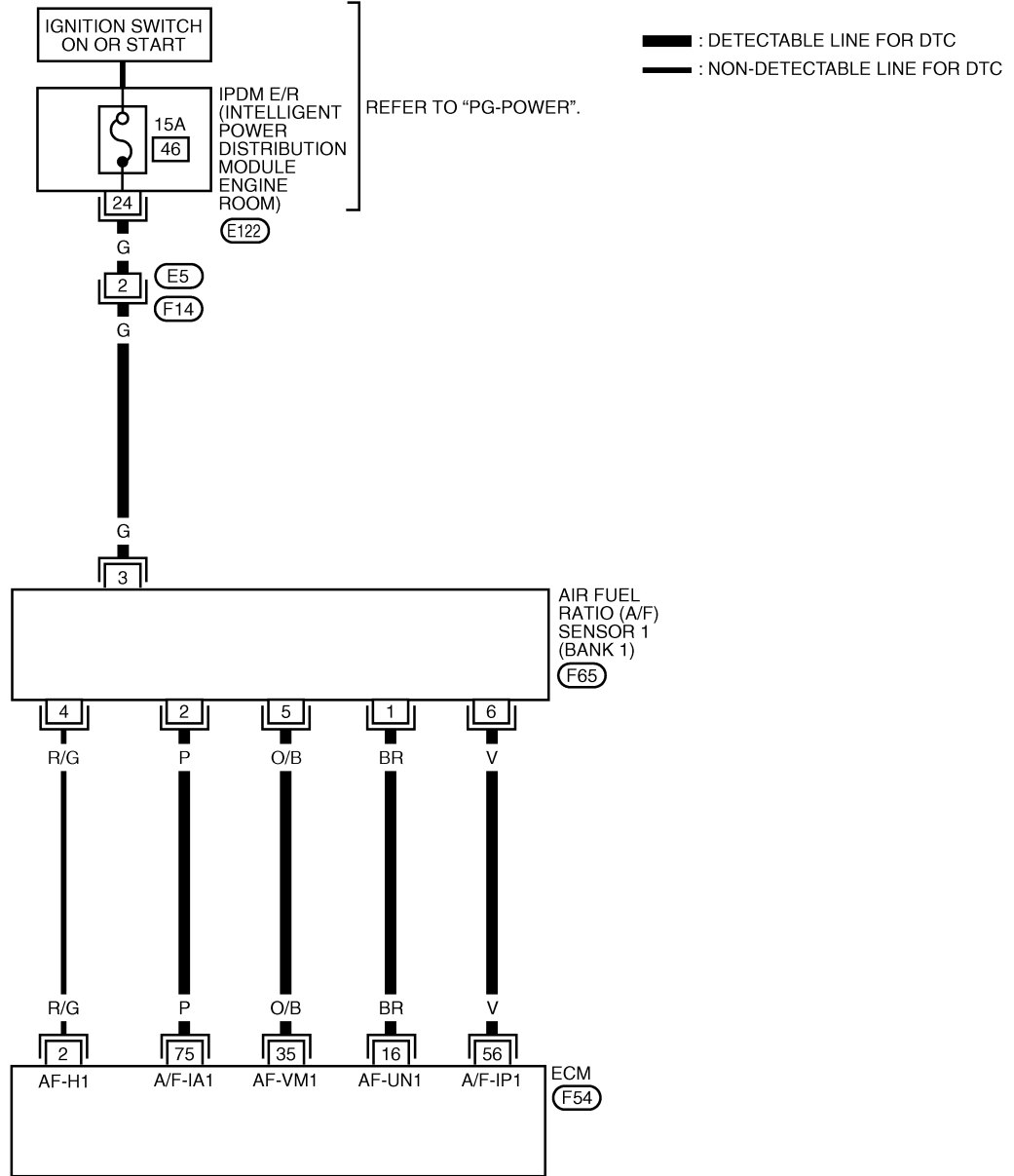

BBWA2503E

DTC P2A00, P2A03 A/F SENSOR 1

Specification data are reference values and are measured between each terminal and ground.
Pulse signal is measured by CONSULT-II.

CAUTION:

Do not use ECM ground terminals when measuring input/output voltage. Doing so may result in damage to the ECM's transistor. Use a ground other than ECM terminals, such as the ground.

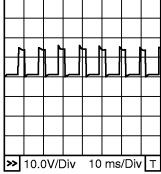
TERMI- NAL NO.	WIRE COLOR	ITEM	CONDITION	DATA (DC Voltage)
2	R/G	A/F sensor 1 heater (Bank 1)	[Engine is running] <ul style="list-style-type: none"> ● Warm-up condition ● Idle speed 	Approximately 5V★ 
16	BR	A/F sensor 1 (Bank 1)	[Engine is running] <ul style="list-style-type: none"> ● Warm-up condition ● Idle speed 	Approximately 3.1V
35	O/B			Approximately 2.6V
56	V			Approximately 2.3V
75	P			Approximately 2.3V

★: Average voltage for pulse signal (Actual pulse signal can be confirmed by oscilloscope.)

DTC P2A00, P2A03 A/F SENSOR 1

BANK 2

EC-AF1B2-01

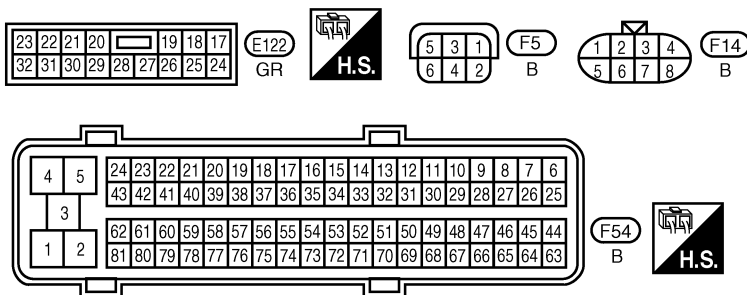
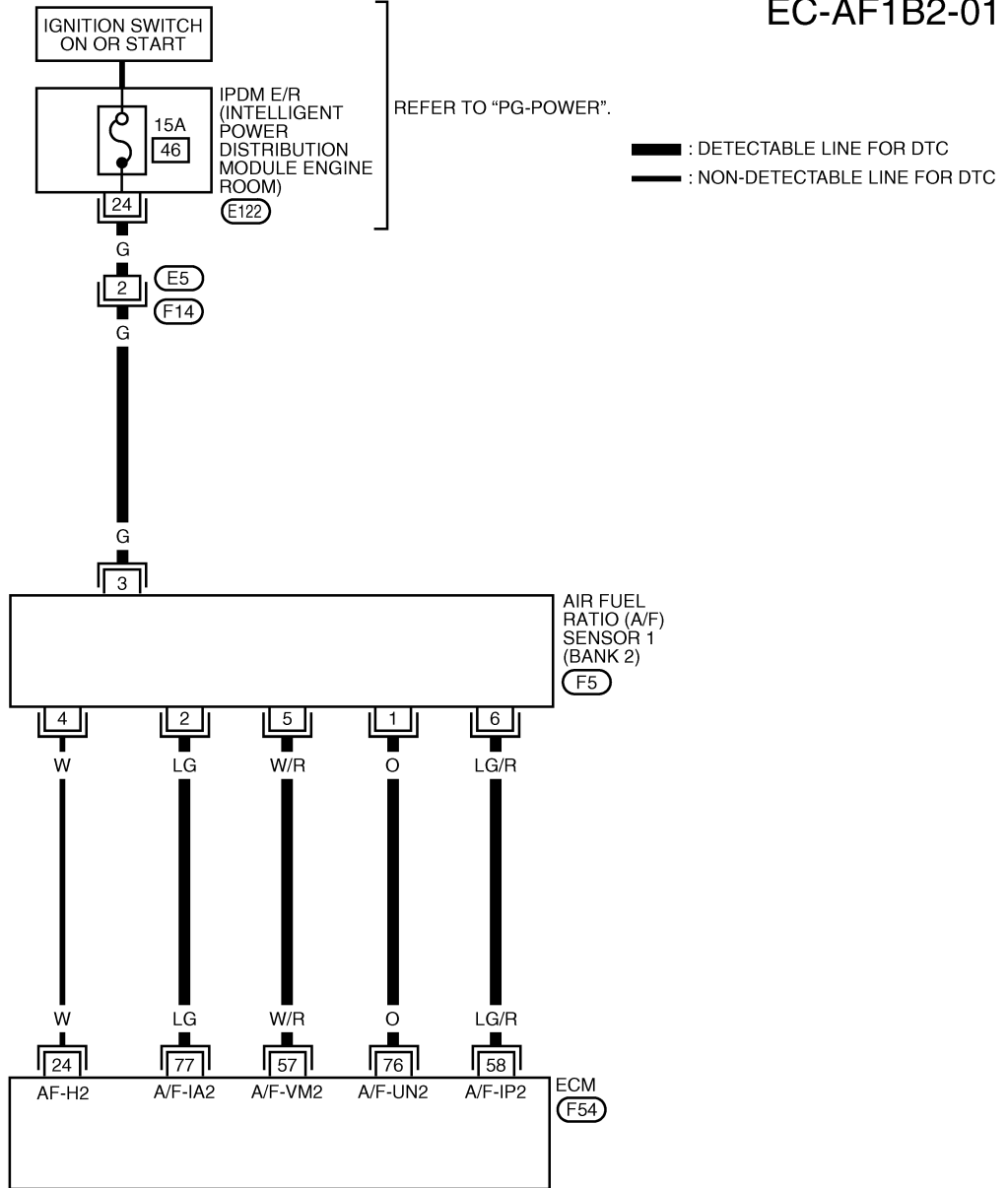

BBWA2504E

DTC P2A00, P2A03 A/F SENSOR 1

Specification data are reference values and are measured between each terminal and ground.
Pulse signal is measured by CONSULT-II.

CAUTION:

Do not use ECM ground terminals when measuring input/output voltage. Doing so may result in damage to the ECM's transistor. Use a ground other than ECM terminals, such as the ground.

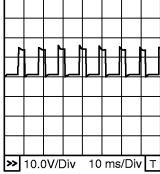
TERMI- NAL NO.	WIRE COLOR	ITEM	CONDITION	DATA (DC Voltage)
24	W	A/F sensor 1 heater (Bank 2)	[Engine is running] <ul style="list-style-type: none"> ● Warm-up condition ● Idle speed 	Approximately 5V★ 
57	W/R	A/F sensor 1 (Bank 2)	[Engine is running] <ul style="list-style-type: none"> ● Warm-up condition ● Idle speed 	Approximately 2.6V
58	LG/R			Approximately 2.3V
76	O			Approximately 3.1V
77	LG			Approximately 2.3V

★: Average voltage for pulse signal (Actual pulse signal can be confirmed by oscilloscope.)

DTC P2A00, P2A03 A/F SENSOR 1

UBS00PFH

Diagnostic Procedure

1. CHECK GROUND CONNECTIONS

1. Turn ignition switch OFF.
2. Loosen and retighten three ground screws on the body. Refer to [EC-158, "Ground Inspection"](#).

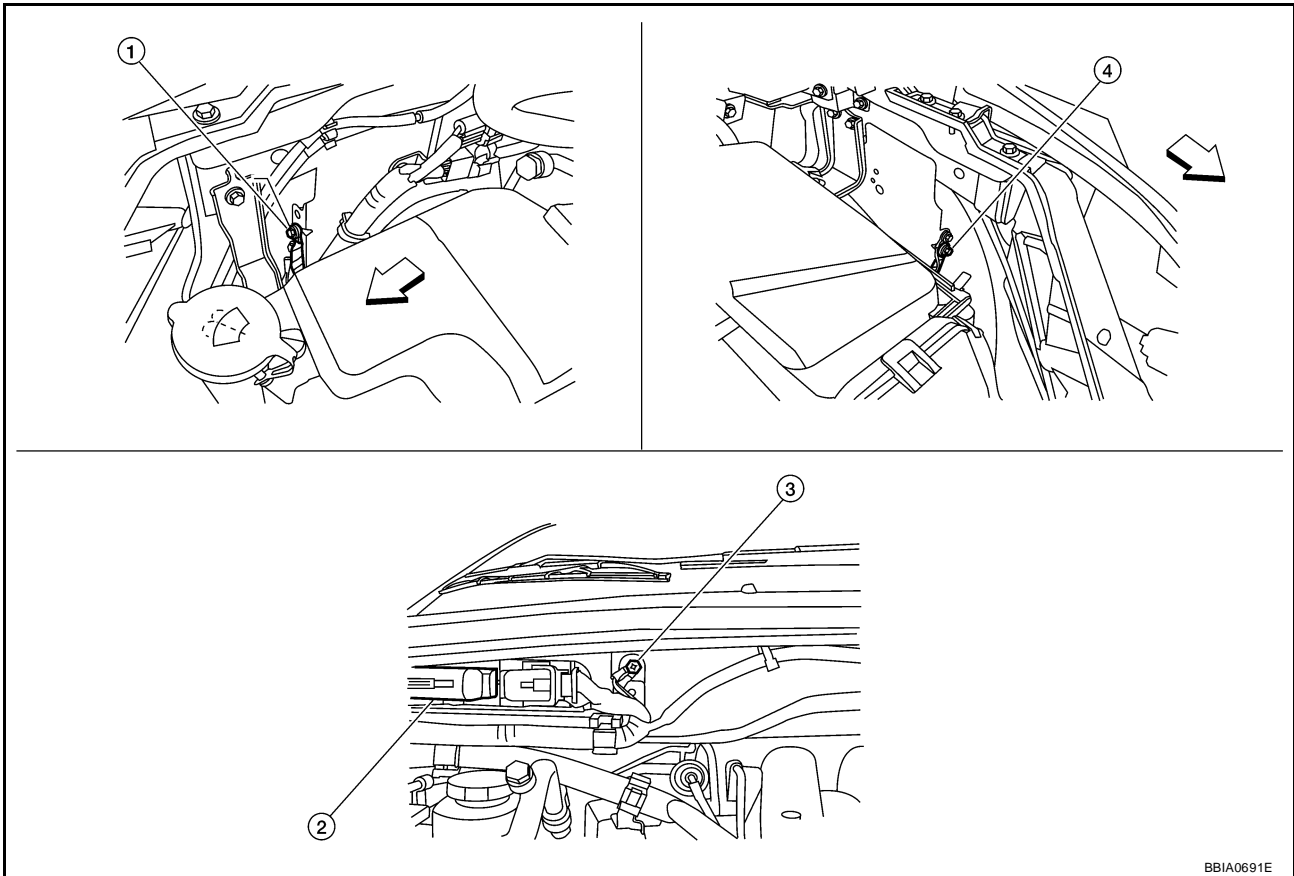

B8IA0691E

← Vehicle front

1. Body ground E24

2. ECM

3. Body ground E9

4. Body ground E15

OK or NG

OK >> GO TO 2.

NG >> Repair or replace ground connections.

DTC P2A00, P2A03 A/F SENSOR 1

2. RETIGHTEN AIR FUEL RATIO (A/F) SENSOR 1

Loosen and retighten the air fuel ratio (A/F) sensor 1.

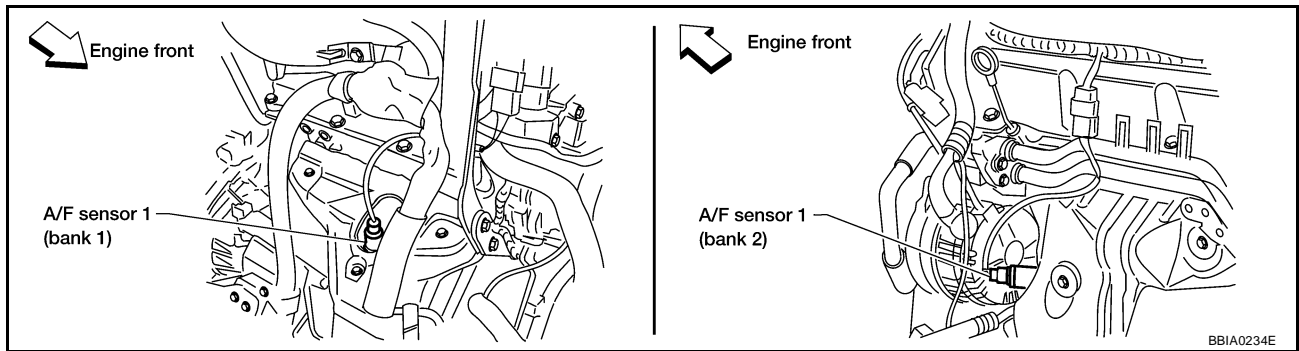

Tightening torque: 50 N-m (5.1 kg-m, 37 ft-lb)

>> GO TO 3.

3. CHECK FOR INTAKE AIR LEAK

1. Start engine and run it at idle.
2. Listen for an intake air leak after the mass air flow sensor.

OK or NG

- OK >> GO TO 4.
- NG >> Repair or replace.

A

EC

C

D

E

F

G

H

I

J

K

L

M

DTC P2A00, P2A03 A/F SENSOR 1

4. CLEAR THE SELF-LEARNING DATA.

④ With CONSULT-II

1. Start engine and warm it up to normal operating temperature.
2. Select "SELF-LEARNING CONT" in "WORK SUPPORT" mode with CONSULT-II.
3. Clear the self-learning control coefficient by touching "CLEAR".
4. Run engine for at least 10 minutes at idle speed.

Is the 1st trip DTC P0171, P0172, P0174 and P0175 detected?

Is it difficult to start engine?

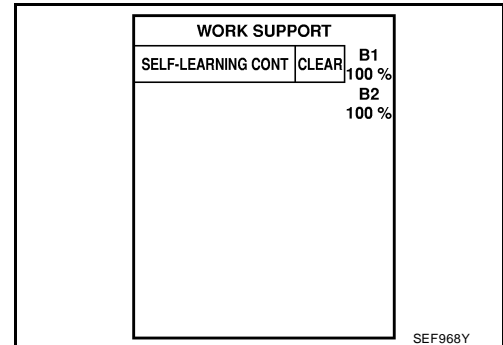

⊗ Without CONSULT-II

1. Start engine and warm it up to normal operating temperature.
2. Turn ignition switch OFF.
3. Disconnect mass air flow sensor harness connector.
4. Restart engine and let it idle for at least 5 seconds.
5. Stop engine and reconnect mass air flow sensor harness connector.
6. Make sure DTC P0102 is displayed.
7. Erase the DTC memory. Refer to [EC-63, "HOW TO ERASE EMISSION-RELATED DIAGNOSTIC INFORMATION"](#).
8. Make sure DTC P0000 is displayed.
9. Run engine for at least 10 minutes at idle speed.

Is the 1st trip DTC P0171, P0172, P0174 and P0175 detected?

Is it difficult to start engine?

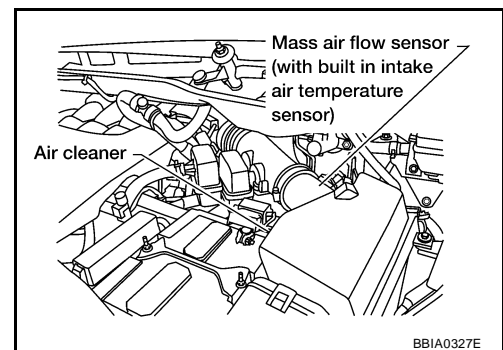

Yes or No

- Yes >> Perform trouble diagnosis for DTC P0171, P0174 or P0172, P0175. Refer to [EC-322, "DTC P0171, P0174 FUEL INJECTION SYSTEM FUNCTION"](#) or [EC-334, "DTC P0172, P0175 FUEL INJECTION SYSTEM FUNCTION"](#).
- No >> GO TO 5.

DTC P2A00, P2A03 A/F SENSOR 1

5. CHECK HARNESS CONNECTOR

1. Turn ignition switch OFF.
2. Disconnect A/F sensor 1 harness connector.

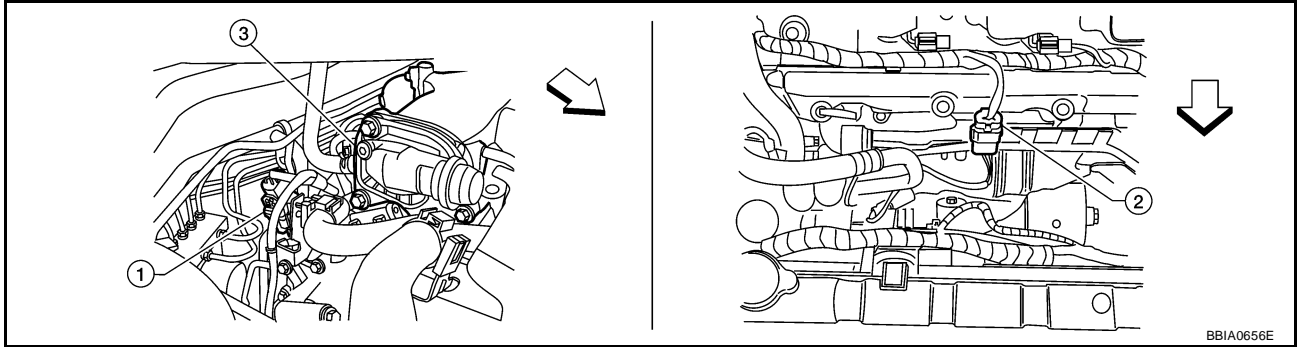

↶ Vehicle front

1. Air fuel ratio (A/F) sensor 1 (bank 1) harness connector
2. Air fuel ratio (A/F) sensor 1 (bank 2) harness connector
3. Intake manifold collector harness connector

3. Check harness connector for water.

Water should not exist.

OK or NG

- OK >> GO TO 6.
- NG >> Repair or replace harness connector.

6. CHECK AIR FUEL RATIO (A/F) SENSOR 1 POWER SUPPLY CIRCUIT

1. Turn ignition switch ON.
2. Check voltage between A/F sensor 1 terminal 3 and ground with CONSULT-II or tester.

Voltage: Battery voltage

OK or NG

- OK >> GO TO 8.
- NG >> GO TO 7.

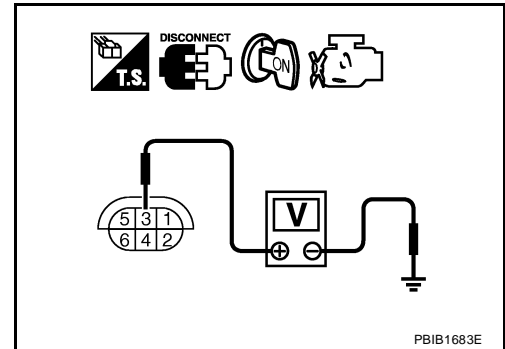

7. DETECT MALFUNCTIONING PART

Check the following.

- Harness connectors E5, F14
- IPDM E/R harness connector E122
- 15A fuse
- Harness for open or short between A/F sensor 1 and fuse

>> Repair or replace harness or connectors.

DTC P2A00, P2A03 A/F SENSOR 1

8. CHECK A/F SENSOR 1 INPUT SIGNAL CIRCUIT FOR OPEN AND SHORT

1. Turn ignition switch OFF.
2. Disconnect ECM harness connector.
3. Check harness continuity between the following terminals.
Refer to Wiring Diagram.

	A/F sensor 1 terminal	ECM terminal
Bank 1	1	16
	2	75
	5	35
	6	56
Bank 2	1	76
	2	77
	5	57
	6	58

Continuity should exist.

4. Check harness continuity between the following terminals and ground.
Refer to Wiring Diagram.

Bank 1		Bank 2	
A/F sensor 1 terminal	ECM terminal	A/F sensor 1 terminal	ECM terminal
1	16	1	76
2	75	2	77
5	35	5	57
6	56	6	58

Continuity should not exist.

5. Also check harness for short to power.

OK or NG

OK >> GO TO 9.

NG >> Repair open circuit or short to ground or short to power in harness or connectors.

9. CHECK A/F SENSOR 1 HEATER

Refer to [EC-175, "Component Inspection"](#) .

OK or NG

OK >> GO TO 10.

NG >> GO TO 11.

10. CHECK INTERMITTENT INCIDENT

Perform [EC-149, "TROUBLE DIAGNOSIS FOR INTERMITTENT INCIDENT"](#) .

OK or NG

OK >> GO TO 11.

NG >> Repair or replace.

DTC P2A00, P2A03 A/F SENSOR 1

11. REPLACE AIR FUEL RATIO (A/F) SENSOR 1

Replace malfunctioning air fuel ratio (A/F) sensor 1.

CAUTION:

- Discard any air fuel ratio (A/F) sensor which has been dropped from a height of more than 0.5 m (19.7 in) onto a hard surface such as a concrete floor; use a new one.
- Before installing new air fuel ratio (A/F) sensor, clean exhaust system threads using Heated Oxygen Sensor Thread Cleaner tool J-43897-18 or J-43897-12 and approved anti-seize lubricant.

>> GO TO 12.

12. CONFIRM A/F ADJUSTMENT DATA

1. Turn ignition switch ON.
2. Select "A/F ADJ-B1" and "A/F ADJ-B2" in "DATA MONITOR" mode with CONSULT-II.
3. Make sure that "0.000" is displayed on CONSULT-II screen.

OK or NG

OK >> **INSPECTION END**
NG >> GO TO 13.

DATA MONITOR	
MONITORING	NO DTC
A/F ADJ-B1	0.000
A/F ADJ-B2	0.000

PBIB3202E

DTC P2A00, P2A03 A/F SENSOR 1

13. CLEAR A/F ADJUSTMENT DATA

With CONSULT-II

1. Start engine and warm it up to normal operating temperature.
2. Select "SELF-LEARNING CONT" in "WORK SUPPORT" mode with CONSULT-II.
3. Clear the self-learning control coefficient by touching "CLEAR".

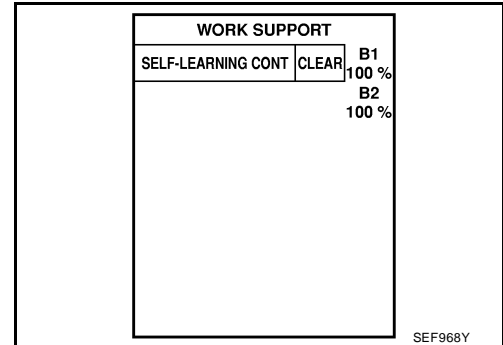

Without CONSULT-II

1. Start engine and warm it up to normal operating temperature.
2. Turn ignition switch OFF.
3. Disconnect mass air flow sensor harness connector.
4. Restart engine and let it idle for at least 5 seconds.
5. Stop engine and reconnect mass air flow sensor harness connector.
6. Make sure DTC P0102 is displayed.
7. Erase the DTC memory. Refer to [EC-63, "HOW TO ERASE EMISSION-RELATED DIAGNOSTIC INFORMATION"](#).
8. Make sure DTC P0000 is displayed.

>> GO TO 14.

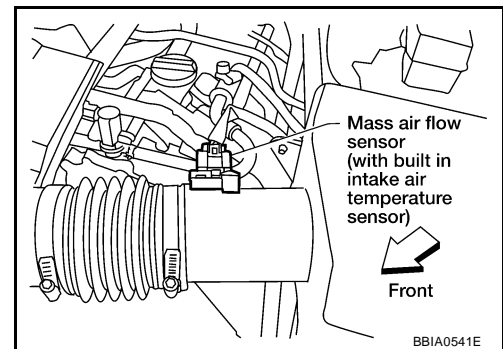

14. CONFIRM A/F ADJUSTMENT DATA

1. Turn ignition switch OFF and then ON.
2. Select "A/F ADJ-B1" and "A/F ADJ-B2" in "DATA MONITOR" mode with CONSULT-II.
3. Make sure that "0.000" is displayed on CONSULT-II screen.

>> INSPECTION END

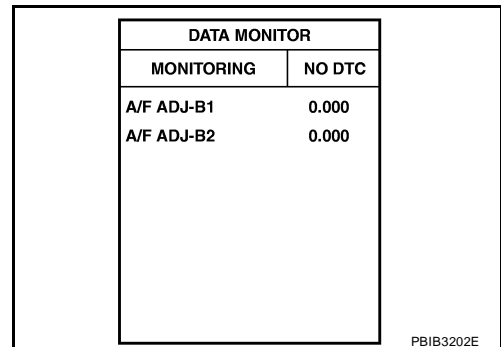

DATA MONITOR	
MONITORING	NO DTC
A/F ADJ-B1	0.000
A/F ADJ-B2	0.000

PBIB3202E

Removal and Installation AIR FUEL RATIO (A/F) SENSOR 1

Refer to [EM-26, "EXHAUST MANIFOLD AND THREE WAY CATALYST"](#).

UBS00PFI

ASCD BRAKE SWITCH

PFP:25320

ASCD BRAKE SWITCH

Component Description

When the brake pedal is depressed, ASCD brake switch is turned OFF and stop lamp switch is turned ON. ECM detects the state of the brake pedal by this input of two kinds (ON/OFF signal).

Refer to [EC-29, "AUTOMATIC SPEED CONTROL DEVICE \(ASCD\)"](#) for the ASCD function.

UBS00PFJ

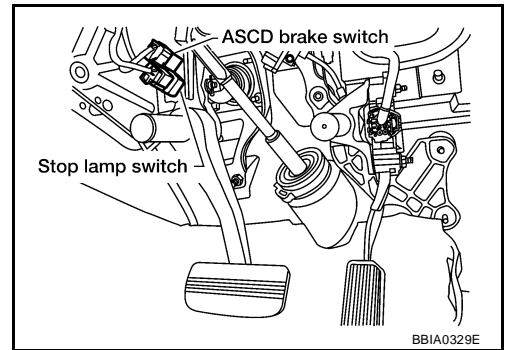

CONSULT-II Reference Value in Data Monitor Mode

UBS00PFK

Specification data are reference values.

MONITOR ITEM	CONDITION		SPECIFICATION
BRAKE SW1 (ASCD brake switch)	● Ignition switch: ON	Brake pedal: Fully released	ON
		Brake pedal: Slightly depressed	OFF
BRAKE SW2 (Stop lamp switch)	● Ignition switch: ON	Brake pedal: Fully released	OFF
		Brake pedal: Slightly depressed	ON

ASCD BRAKE SWITCH

UBS00PFL

Wiring Diagram

EC-ASCBOF-01

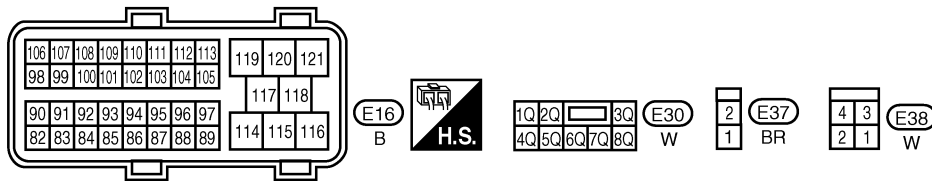
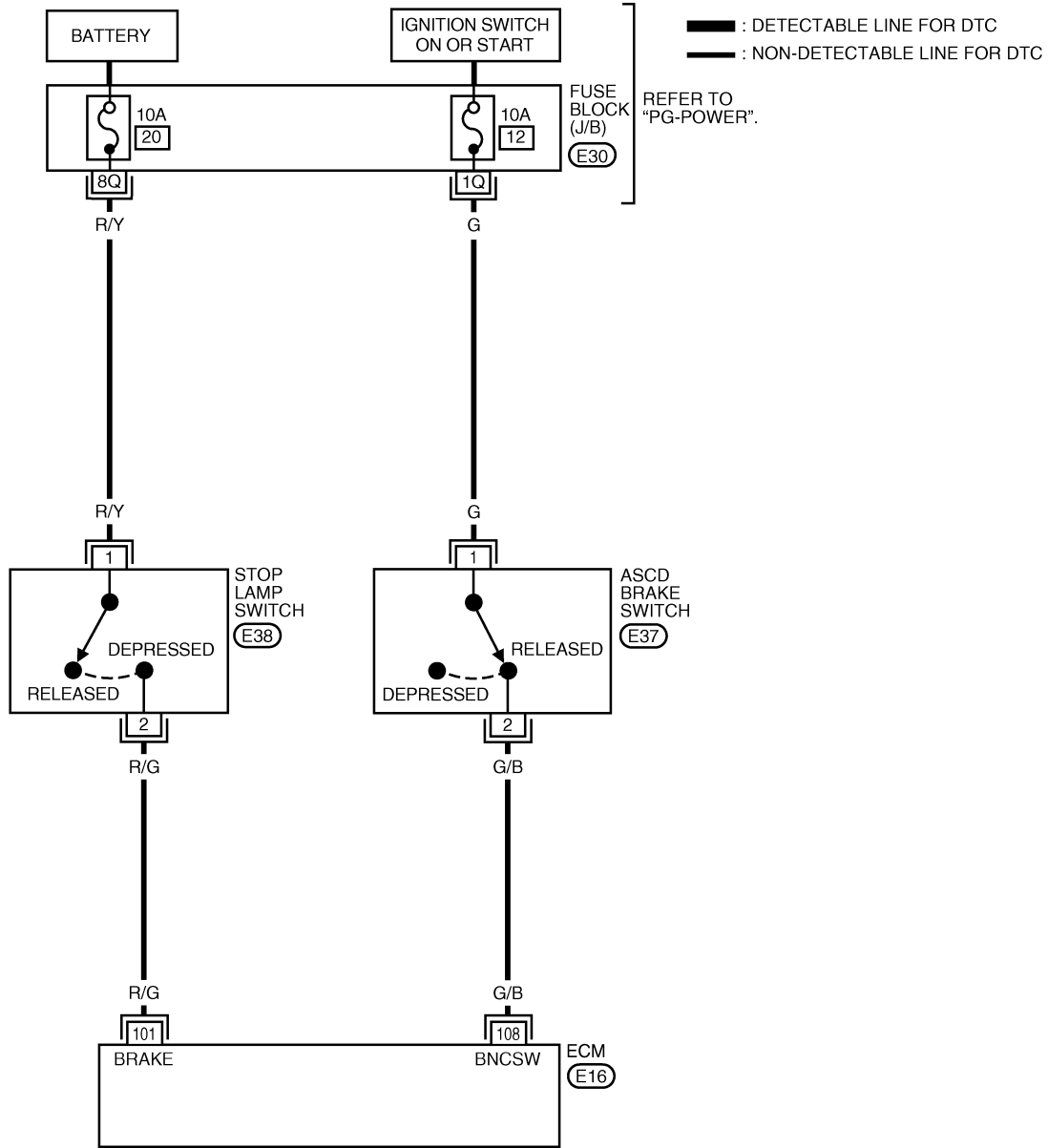

BBWA2542E

ASCD BRAKE SWITCH

Specification data are reference values and are measured between each terminal and ground.

CAUTION:

Do not use ECM ground terminals when measuring input/output voltage. Doing so may result in damage to the ECM's transistor. Use a ground other than ECM terminals, such as the ground.

TER-MINAL NO.	WIRE COLOR	ITEM	CONDITION	DATA (DC Voltage)
101	R/G	Stop lamp switch	[Ignition switch: OFF] ● Brake pedal: Fully released	Approximately 0V
			[Ignition switch: OFF] ● Brake pedal: Slightly depressed	BATTERY VOLTAGE (11 - 14V)
108	G/B	ASCD brake switch	[Ignition switch: ON] ● Brake pedal: Fully released	BATTERY VOLTAGE (11 - 14V)
			[Ignition switch: ON] ● Brake pedal: Slightly depressed	Approximately 0V

Diagnostic Procedure

UBS00PFM

1. CHECK OVERALL FUNCTION-I

With CONSULT-II

- Turn ignition switch ON.
- Select "BRAKE SW1" in "DATA MONITOR" mode with CONSULT-II.
- Check "BRAKE SW1" indication under the following conditions.

CONDITION	INDICATION
Brake pedal: Slightly depressed	OFF
Brake pedal: Fully released	ON

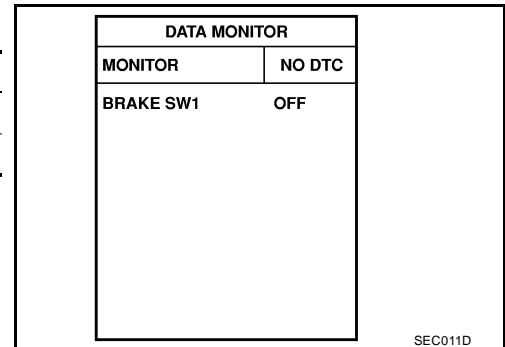

Without CONSULT-II

- Turn ignition switch ON.
- Check voltage between ECM terminal 108 and ground under the following conditions.

CONDITION	VOLTAGE
Brake pedal: Slightly depressed	Approximately 0V
Brake pedal: Fully released	Battery voltage

OK or NG

- OK >> GO TO 2.
NG >> GO TO 3.

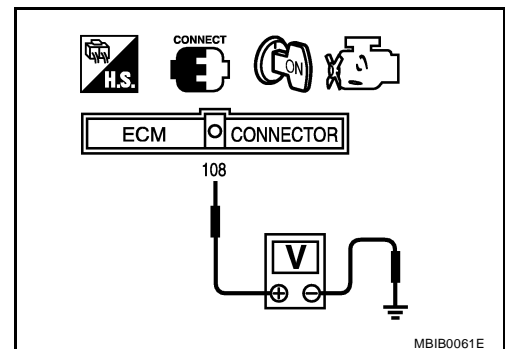

ASCD BRAKE SWITCH

2. CHECK OVERALL FUNCTION-II

With CONSULT-II

Check "BRAKE SW2" indication in "DATA MONITOR" mode.

CONDITION	INDICATION
Brake pedal: Fully released	OFF
Brake pedal: Slightly depressed	ON

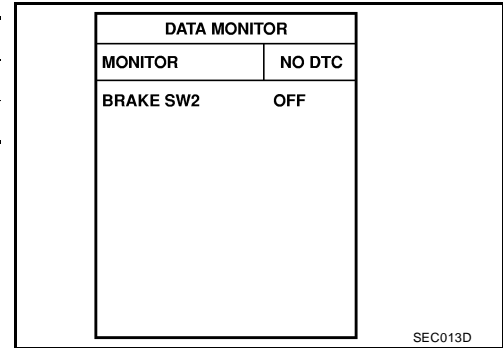

Without CONSULT-II

Check voltage between ECM terminal 101 and ground under the following conditions.

CONDITION	VOLTAGE
Brake pedal: Fully released	Approximately 0V
Brake pedal: Slightly depressed	Battery voltage

OK or NG

- OK >> **INSPECTION END**
- NG >> GO TO 7.

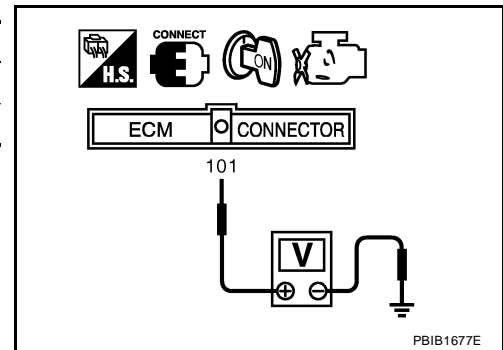

3. CHECK ASCD BRAKE SWITCH POWER SUPPLY CIRCUIT

1. Turn ignition switch OFF.
2. Disconnect ASCD brake switch harness connector.
3. Turn ignition switch ON.

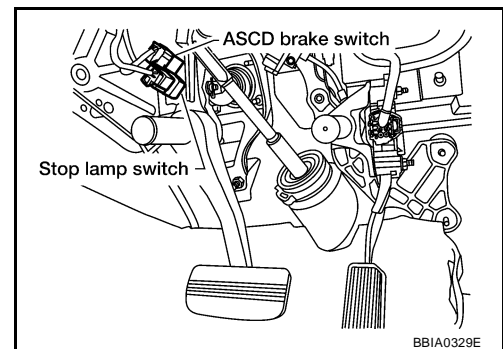

4. Check voltage between ASCD brake switch terminal 1 and ground with CONSULT-II or tester.

Voltage: Battery voltage

OK or NG

- OK >> GO TO 5.
- NG >> GO TO 4.

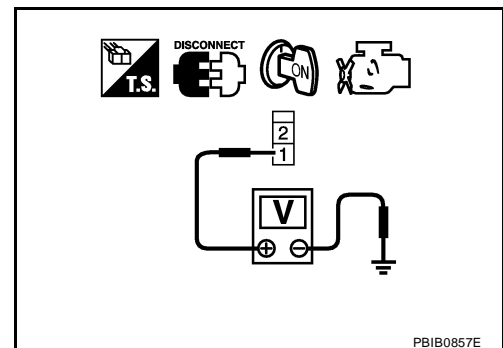

ASCD BRAKE SWITCH

4. DETECT MALFUNCTIONING PART

Check the following.

- Fuse block (J/B) connector E30
- 10A fuse
- Harness for open or short between ASCD brake switch and fuse

>> Repair open circuit or short to ground or short to power in harness or connectors.

5. CHECK ASCD BRAKE SWITCH INPUT SIGNAL CIRCUIT FOR OPEN AND SHORT

1. Turn ignition switch OFF.
2. Disconnect ECM harness connector.
3. Check harness continuity between ECM terminal 108 and ASCD brake switch terminal 2. Refer to Wiring Diagram.

Continuity should exist.

4. Also check harness for short to ground and short to power.

OK or NG

OK >> GO TO 6.

NG >> Repair open circuit or short to ground or short to power in harness or connectors.

6. CHECK ASCD BRAKE SWITCH

Refer to [EC-667, "Component Inspection"](#).

OK or NG

OK >> GO TO 11.

NG >> Replace ASCD brake switch.

7. CHECK STOP LAMP SWITCH POWER SUPPLY CIRCUIT

1. Turn ignition switch OFF.
2. Disconnect stop lamp switch harness connector.

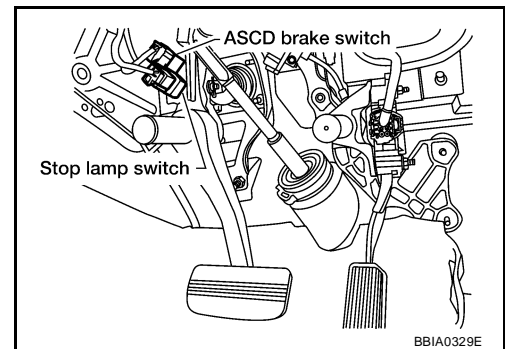

3. Check voltage between stop lamp switch terminal 1 and ground with CONSULT-II or tester.

Voltage: Battery voltage

OK or NG

OK >> GO TO 9.

NG >> GO TO 8.

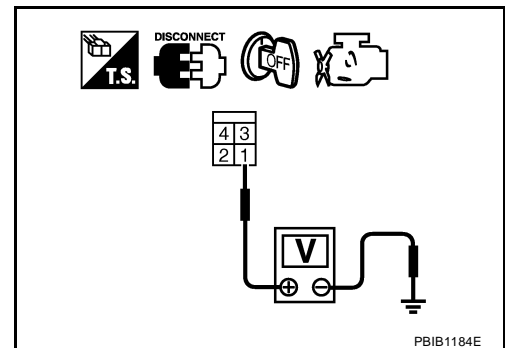

ASCD BRAKE SWITCH

8. DETECT MALFUNCTIONING PART

Check the following.

- Fuse block (J/B) connector E30
- 10A fuse
- Harness for open or short between stop lamp switch and battery

>> Repair open circuit or short to ground or short to power in harness or connectors.

9. CHECK STOP LAMP SWITCH INPUT SIGNAL CIRCUIT FOR OPEN AND SHORT

1. Disconnect ECM harness connector.
2. Check harness continuity between ECM terminal 101 and stop lamp switch terminal 2.
Refer to Wiring Diagram.

Continuity should exist.

3. Also check harness for short to ground and short to power.

OK or NG

OK >> GO TO 10.

NG >> Repair open circuit or short to ground or short to power in harness or connectors.

10. CHECK STOP LAMP SWITCH

Refer to [EC-667, "Component Inspection"](#) .

OK or NG

OK >> GO TO 11.

NG >> Replace stop lamp switch.

11. CHECK INTERMITTENT INCIDENT

Refer to [EC-149, "TROUBLE DIAGNOSIS FOR INTERMITTENT INCIDENT"](#) .

>> **INSPECTION END**

ASCD BRAKE SWITCH

UBS00PFN

Component Inspection ASCD BRAKE SWITCH

1. Turn ignition switch OFF.
2. Disconnect ASCD brake switch harness connector.
3. Check harness continuity between ASCD brake switch terminals 1 and 2 under the following conditions.

Condition	Continuity
Brake pedal: Fully released	Should exist
Brake pedal: Slightly depressed	Should not exist

If NG, adjust ASCD brake switch installation, refer to [BR-6](#), "[BRAKE PEDAL](#)", and perform step 3 again.

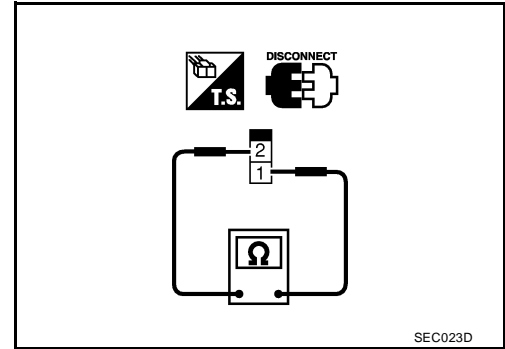

STOP LAMP SWITCH

1. Turn ignition switch OFF.
2. Disconnect stop lamp switch harness connector.
3. Check harness continuity between stop lamp switch terminals 1 and 2 under the following conditions.

Condition	Continuity
Brake pedal: Fully released	Should not exist
Brake pedal: Slightly depressed	Should exist

If NG, adjust stop lamp switch installation, refer to [BR-6](#), "[BRAKE PEDAL](#)", and perform step 3 again.

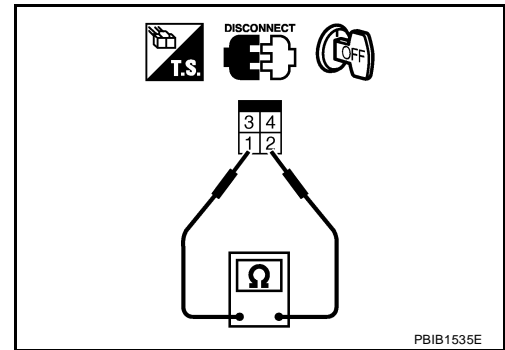

A
EC
C
D
E
F
G
H
I
J
K
L
M

ASC D INDICATOR

PF P:24814

ASC D INDICATOR

Component Description

UBS00PFO

ASC D indicator lamp illuminates to indicate ASC D operation status. Lamp has two indicators, CRUISE and SET, and is integrated in combination meter.

CRUISE indicator illuminates when MAIN switch on ASC D steering switch is turned ON to indicate that ASC D system is ready for operation.

SET indicator illuminates when following conditions are met.

- CRUISE indicator is illuminated.
- SET/COAST switch on ASC D steering switch is turned ON while vehicle speed is within the range of ASC D setting.

SET indicator remains lit during ASC D control.

Refer to [EC-29, "AUTOMATIC SPEED CONTROL DEVICE \(ASC D\)"](#) for the ASC D function.

CONSULT-II Reference Value in Data Monitor Mode

UBS00PFP

Specification data are reference value.

MONITOR ITEM	CONDITION		SPECIFICATION
CRUISE LAMP	● Ignition switch: ON	MAIN switch: Pressed at the 1st time → at the 2nd time	ON → OFF
SET LAMP	● MAIN switch: ON ● When vehicle speed is between 40 km/h (25 MPH) and 144 km/h (89 MPH)	ASC D: Operating	ON
		ASC D: Not operating	OFF

ASC D INDICATOR

UBS00PFQ

Wiring Diagram

EC-ASCIND-01

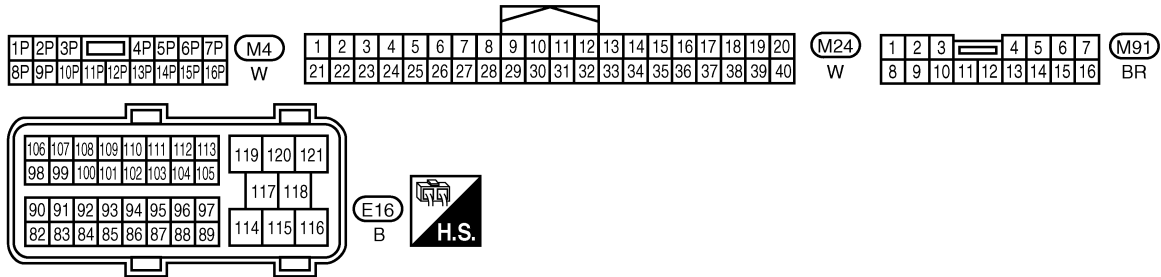
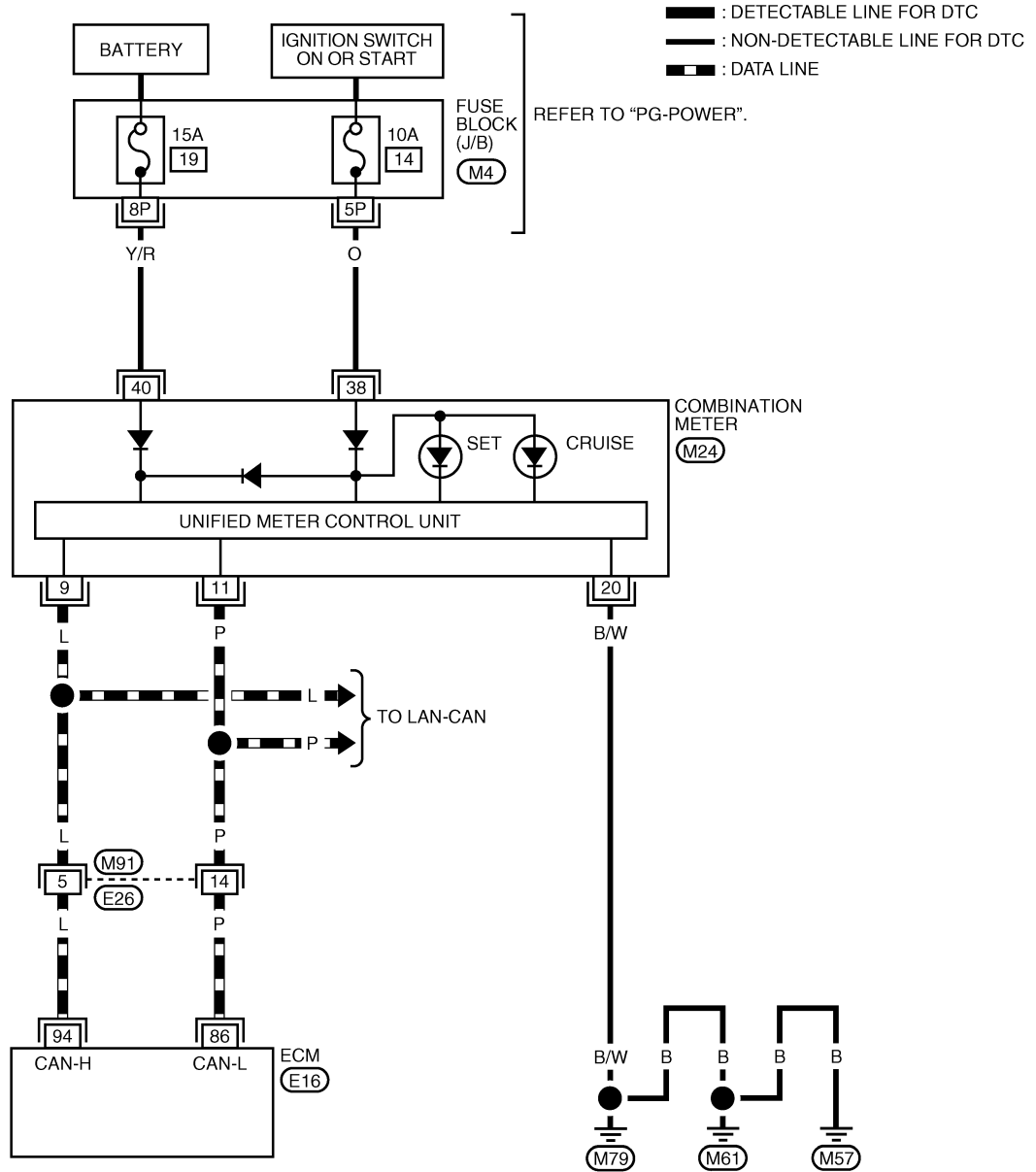

BBWA2543E

ASCD INDICATOR

UBS00PFR

Diagnostic Procedure

1. CHECK OVERALL FUNCTION

Check ASCD indicator under the following conditions.

ASCD INDICATOR	CONDITION		SPECIFICATION
CRUISE LAMP	● Ignition switch: ON	MAIN switch: Pressed at the 1st time → at the 2nd time	ON → OFF
SET LAMP	● MAIN switch: ON ● When vehicle speed is between 40 km/h (25 MPH) and 144 km/h (89 MPH)	ASCD: Operating	ON
		ASCD: Not operating	OFF

OK or NG

OK >> **INSPECTION END**

NG >> GO TO 2.

2. CHECK DTC

Check that DTC U1000 or U1001 is not displayed.

OK or NG

OK >> GO TO 3.

NG >> Perform trouble diagnoses for DTC U1000, U1001. Refer to [EC-159, "DTC U1000, U1001 CAN COMMUNICATION LINE"](#) .

3. CHECK COMBINATION METER OPERATION

Does combination meter operate normally?

Yes or No

Yes >> GO TO 4.

No >> Check combination meter circuit. Refer to [DI-5, "COMBINATION METERS"](#) .

4. CHECK INTERMITTENT INCIDENT

Refer to [EC-149, "TROUBLE DIAGNOSIS FOR INTERMITTENT INCIDENT"](#) .

>> **INSPECTION END**

ELECTRICAL LOAD SIGNAL

ELECTRICAL LOAD SIGNAL

PF:25350

Description

UBS00PFS

The electrical load signal (Headlamp switch signal, rear window defogger switch signal, etc.) is transferred through the CAN communication line from BCM to ECM via IPDM E/R.

A

EC

CONSULT-II Reference Value in Data Monitor Mode

UBS00PFT

Specification data are reference values.

C

MONITOR ITEM	CONDITION		SPECIFICATION
LOAD SIGNAL	● Ignition switch: ON	Rear window defogger switch is ON and/or lighting switch is in 2nd.	ON
		Rear window defogger switch is OFF and lighting switch is OFF.	OFF
HEATER FAN SW	● Ignition switch: ON	Heater fan: Operating	ON
		Heater fan: Not operating	OFF

D

E

Diagnostic Procedure

UBS00PFU

1. CHECK LOAD SIGNAL CIRCUIT OVERALL FUNCTION-I

F

- Turn ignition switch ON.
- Connect CONSULT-II and select "DATA MONITOR" mode.
- Select "LOAD SIGNAL" and check indication under the following conditions.

G

Condition	Indication
Rear window defogger switch: ON	ON
Rear window defogger switch: OFF	OFF

DATA MONITOR	
MONITORING	NO DTC
LOAD SIGNAL	ON

PBIB0103E

H

I

J

OK or NG

- OK >> GO TO 2.
NG >> GO TO 4.

K

2. CHECK LOAD SIGNAL CIRCUIT OVERALL FUNCTION-II

L

Check "LOAD SIGNAL" indication under the following conditions.

Condition	Indication
Lighting switch: ON at 2nd position	ON
Lighting switch: OFF	OFF

DATA MONITOR	
MONITORING	NO DTC
LOAD SIGNAL	ON

PBIB0103E

M

OK or NG

- OK >> GO TO 3.
NG >> GO TO 5.

ELECTRICAL LOAD SIGNAL

3. CHECK HEATER FAN SIGNAL CIRCUIT OVERALL FUNCTION

Check "HEATER FAN SW" in "DATA MONITOR" mode with CONSULT-II under the following conditions.

Condition	LOAD SIGNAL
Heater fan control switch: ON	ON
Heater fan control switch: OFF	OFF

OK or NG

OK >> **INSPECTION END.**
NG >> GO TO 6.

DATA MONITOR	
MONITORING	NO DTC
HEATER FAN SW	ON

PBIB1995E

4. CHECK REAR WINDOW DEFOGGER SYSTEM

Refer to [GW-87, "REAR WINDOW DEFOGGER"](#) .

>> **INSPECTION END**

5. CHECK HEADLAMP SYSTEM

Refer to [LT-5, "HEADLAMP \(FOR USA\)"](#) or [LT-28, "HEADLAMP \(FOR CANADA\) - DAYTIME LIGHT SYSTEM -"](#) .

>> **INSPECTION END**

6. CHECK HEATER FAN CONTROL SYSTEM

Refer to [ATC-32, "TROUBLE DIAGNOSIS"](#) or [MTC-32, "TROUBLE DIAGNOSIS"](#) .

>> **INSPECTION END**

ELECTRONIC CONTROLLED ENGINE MOUNT

ELECTRONIC CONTROLLED ENGINE MOUNT

PFV:11270

System Description

UBS00PFV

Sensor	Input Signal to ECM	ECM function	Actuator
Crankshaft position sensor (POS) Camshaft position sensor (PHASE)	Engine speed	Engine mount control	Electronic controlled engine mount
Wheel sensor	Vehicle speed*		

*: This signal is sent to the ECM through CAN communication line.

The ECM controls the engine mount operation corresponding to the engine speed and the vehicle speed. The control system has 2-step control [Soft/Hard]

Vehicle condition	Engine mount control
Engine speed: Below 950 rpm	Soft
Engine speed: Above 950 rpm	Hard

CONSULT-II Reference Value in Data Monitor Mode

UBS00PFV

Specification data are reference values.

MONITOR ITEM	CONDITION		SPECIFICATION
ENGINE MOUNT	● Engine: Running	Engine speed: Below 950 rpm	IDLE
		Engine speed: Above 950 rpm	TRVL

ELECTRONIC CONTROLLED ENGINE MOUNT

Wiring Diagram

UBS00PFX

EC-EMNT-01

: DETECTABLE LINE FOR DTC
 : NON-DETECTABLE LINE FOR DTC

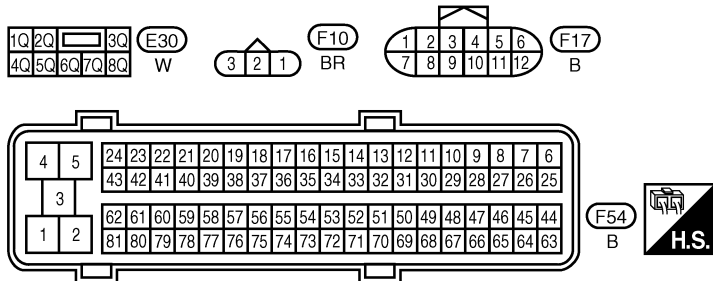
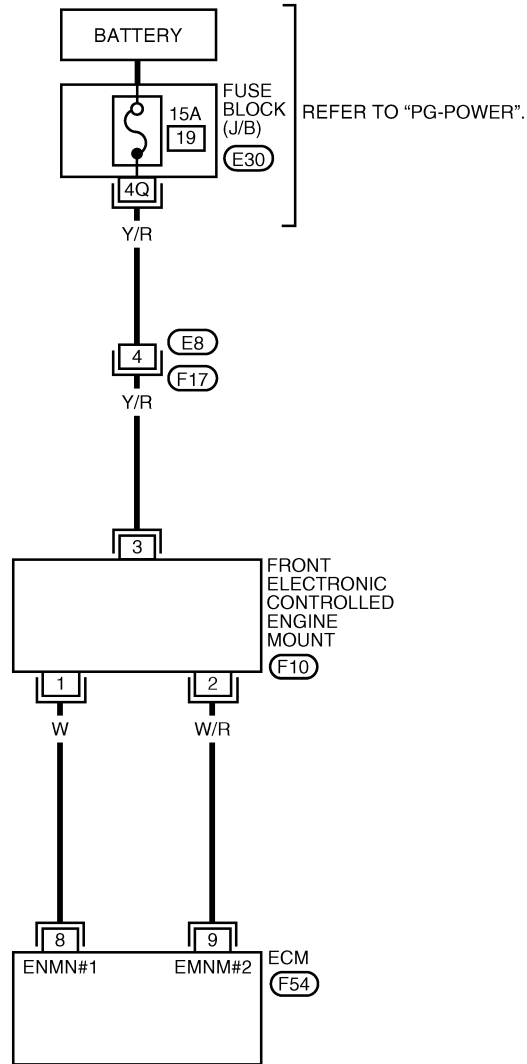

BBWA2007E

ELECTRONIC CONTROLLED ENGINE MOUNT

Specification data are reference values and are measured between each terminal and ground.

CAUTION:

Do not use ECM ground terminals when measuring input/output voltage. Doing so may result in damage to the ECM's transistor. Use a ground other than ECM terminals, such as the ground.

TER-MINAL NO.	WIRE COLOR	ITEM	CONDITION	DATA (DC Voltage)
8	W	Electronic controlled engine mount-1	[Engine is running] ● Engine speed: Above 950 rpm	BATTERY VOLTAGE (11 - 14V)
			[Engine is running] ● For 2 seconds after engine speed: 950 rpm or less	0 - 1.0V
			[Engine is running] ● 2 seconds after engine speed: 950 rpm or less	2.0 - 3.0V
9	W/R	Electronic controlled engine mount-2	[Engine is running] ● Engine speed: Below 950 rpm	BATTERY VOLTAGE (11 - 14V)
			[Engine is running] ● For 2 seconds after engine speed: 950 rpm or more	0 - 1.0V
			[Engine is running] ● 2 seconds after engine speed: 950 rpm or more	2.0 - 3.0V

Diagnostic Procedure

UBS00PFY

1. CHECK OVERALL FUNCTION

Ⓜ With CONSULT-II

1. Start engine and warm it up to normal operating temperature.
2. Select "ENGINE MOUNTING" in "ACTIVE TEST" mode with CONSULT-II and touch "ON/OFF" on the CONSULT-II screen.
3. Check that the motor operating sound is heard from front electronic controlled engine mount for about 0.5 seconds according to the switching condition of "ENGINE MOUNTING".

ACTIVE TEST	
ENGINE MOUNTING	IDLE
MONITOR	
ENG SPEED	XXX rpm
COOLANT TEMP/S	XXX °C

SEC237C

ⓧ Without CONSULT-II

1. Make sure that gear position is P or N.
2. Start engine and let it idle.
3. Change the engine speed from idle to more than 1,000 rpm and then return to idle (with vehicle stopped).
4. Check that the motor operating sound is heard from front electronic controlled engine mount for about 0.5 seconds when changing engine speed.
It is better to hear the operating sound around the left side front wheel house.

OK or NG

- OK >> **INSPECTION END**
- NG >> **GO TO 2.**

ELECTRONIC CONTROLLED ENGINE MOUNT

2. CHECK ELECTRONIC CONTROLLED ENGINE MOUNT POWER SUPPLY CIRCUIT

1. Turn ignition switch OFF.
2. Disconnect electronic controlled engine mount harness connector.

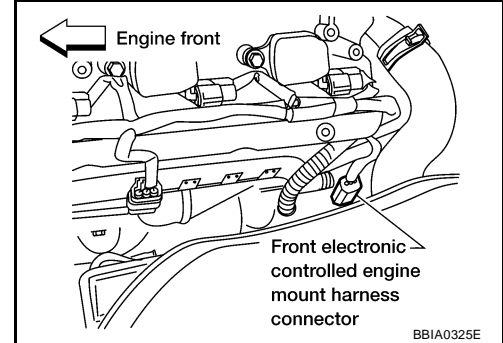

3. Check voltage between electronic controlled engine mount terminal 3 and ground with CONSULT-II or tester.

Voltage: Battery voltage

OK or NG

- OK >> GO TO 4.
- NG >> GO TO 3.

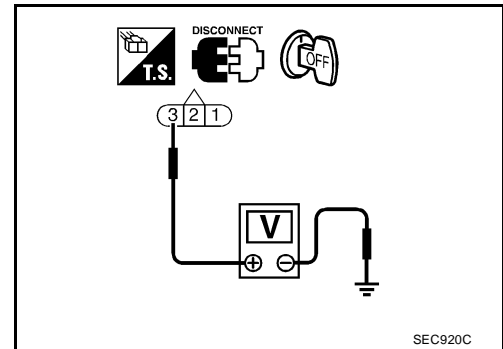

3. DETECT MALFUNCTIONING PART

Check the following.

- Harness connectors E8, F17
- Fuse block (J/B) connector E30
- 15A fuse
- Harness for open and short between electronic controlled engine mount and battery

>> Repair harness or connectors.

4. CHECK ELECTRONIC CONTROLLED ENGINE MOUNT OUTPUT SIGNAL CIRCUIT FOR OPEN AND SHORT

1. Turn ignition switch OFF.
2. Disconnect ECM harness connector.
3. Check harness continuity between ECM terminals and electronic engine mount terminals as follows. Refer to Wiring Diagram.

ECM terminal	Electronic controlled engine mount terminal
8	1
9	2

Continuity should exist.

4. Also check harness for short to ground and short to power.

OK or NG

- OK >> GO TO 5.
- NG >> Repair open circuit or short to ground or short to power in harness or connectors.

ELECTRONIC CONTROLLED ENGINE MOUNT

5. CHECK ELECTRONIC CONTROLLED ENGINE MOUNT

Visually check electronic controlled engine mount.

OK or NG

OK >> GO TO 6.

NG >> Replace electronic controlled engine mount.

6. CHECK INTERMITTENT INCIDENT

Refer to [EC-149, "TROUBLE DIAGNOSIS FOR INTERMITTENT INCIDENT"](#) .

>> **INSPECTION END**

A

EC

C

D

E

F

G

H

I

J

K

L

M

FUEL INJECTOR

PF16600

FUEL INJECTOR

Component Description

UBS00PFZ

The fuel injector is a small, precise solenoid valve. When the ECM supplies a ground to the fuel injector circuit, the coil in the fuel injector is energized. The energized coil pulls the ball valve back and allows fuel to flow through the fuel injector into the intake manifold. The amount of fuel injected depends upon the injection pulse duration. Pulse duration is the length of time the fuel injector remains open. The ECM controls the injection pulse duration based on engine fuel needs.

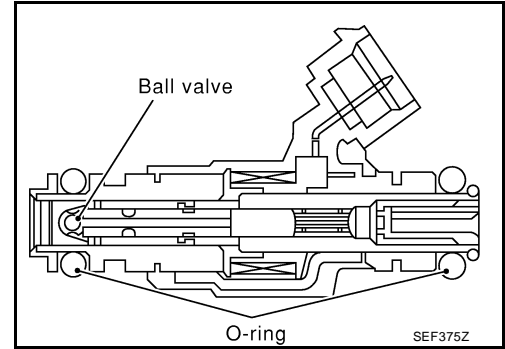

CONSULT-II Reference Value in Data Monitor Mode

UBS00PG0

Specification data are reference values.

MONITOR ITEM	CONDITION	SPECIFICATION
B/FUEL SCHDL	● EC-139, "TROUBLE DIAGNOSIS - SPECIFICATION VALUE" .	
INJ PULSE-B1 INJ PULSE-B2	● Engine: After warming up ● Shift lever: P or N	Idle 2.0 - 3.0 msec
	● Air conditioner switch: OFF ● No load	2,000 rpm 1.9 - 2.9 msec

FUEL INJECTOR

Wiring Diagram

UBS00PG1

EC-INJECT-01

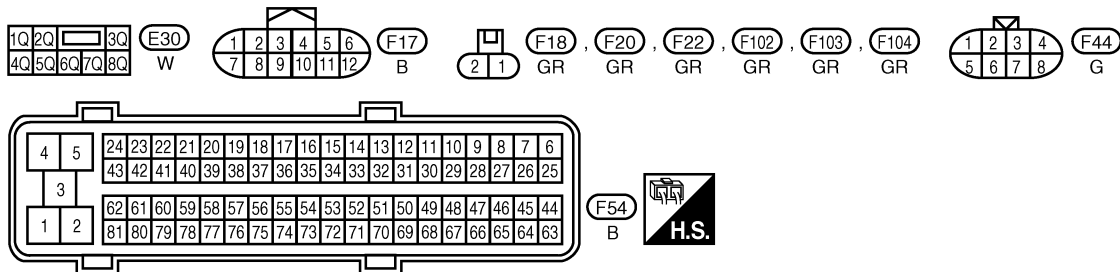
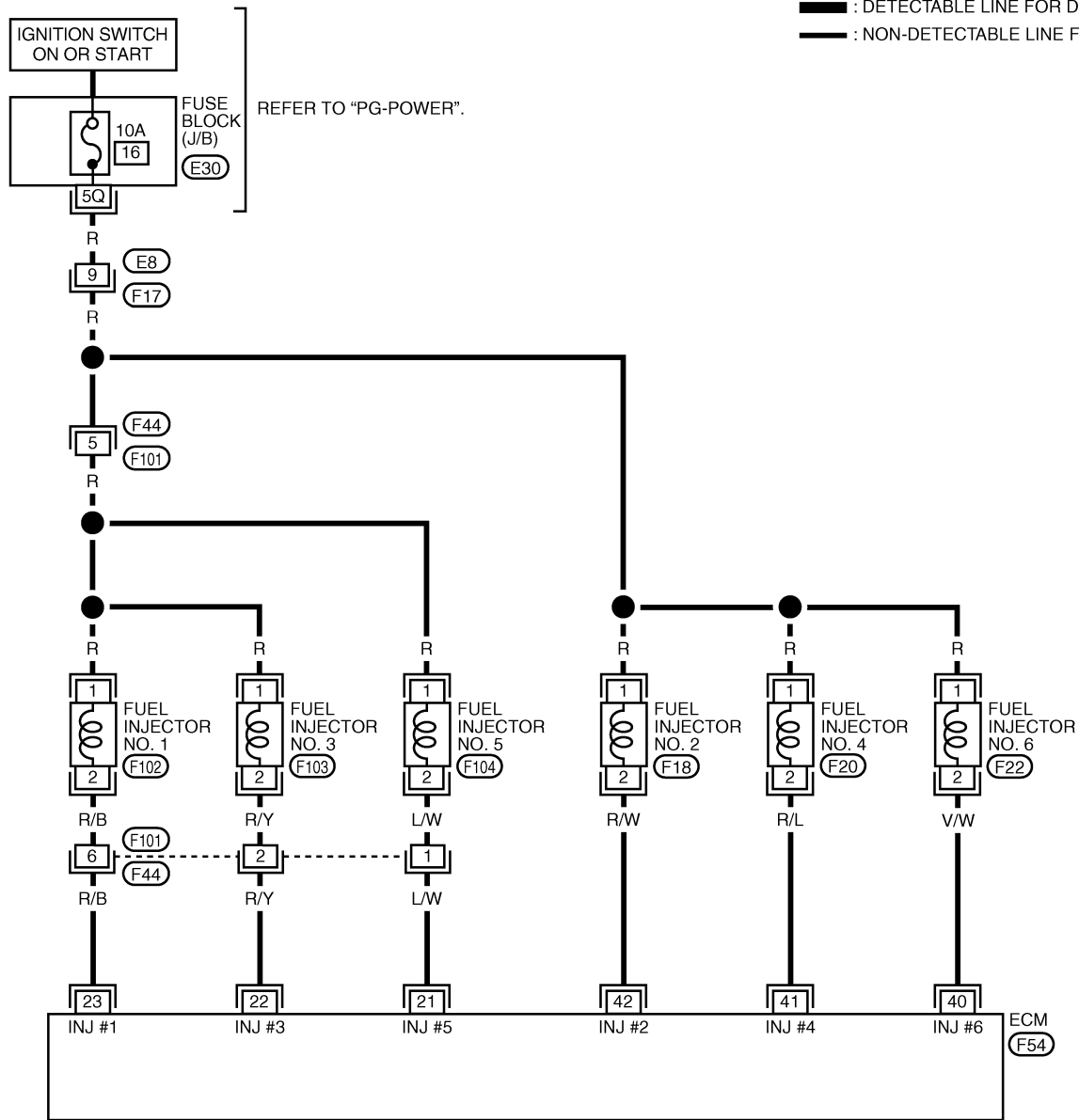

BBWA2539E

FUEL INJECTOR

Specification data are reference values and are measured between each terminal and ground.
Pulse signal is measured by CONSULT-II.

CAUTION:

Do not use ECM ground terminals when measuring input/output voltage. Doing so may result in damage to the ECM's transistor. Use a ground other than ECM terminals, such as the ground.

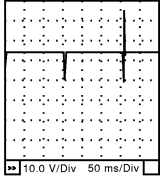
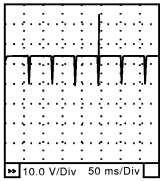
TER-MINAL NO.	WIRE COLOR	ITEM	CONDITION	DATA (DC Voltage)	
21	L/W	Fuel injector No. 5	<p>[Engine is running]</p> <ul style="list-style-type: none"> ● Warm-up condition ● Idle speed <p>NOTE: The pulse cycle changes depending on rpm at idle</p>	<p>BATTERY VOLTAGE (11 - 14V) ★</p>  <p>SEC984C</p>	
22	R/Y	Fuel injector No. 3		<p>[Engine is running]</p> <ul style="list-style-type: none"> ● Warm-up condition ● Engine speed: 2,000 rpm. 	<p>BATTERY VOLTAGE (11 - 14V) ★</p>  <p>SEC985C</p>
23	R/B	Fuel injector No. 1			
40	V/W	Fuel injector No. 6			
41	R/L	Fuel injector No. 4			
42	R/W	Fuel injector No. 2			

★: Average voltage for pulse signal (Actual pulse signal can be confirmed by oscilloscope.)

Diagnostic Procedure

UBS00PG2

1. INSPECTION START

Turn ignition switch to START.

Is any cylinder ignited?

Yes or No

- Yes (With CONSULT-II)>>GO TO 2.
- Yes (Without CONSULT-II)>>GO TO 3.
- No >> GO TO 7.

2. CHECK OVERALL FUNCTION

Ⓜ **With CONSULT-II**

- Start engine.
- Perform "POWER BALANCE" in "ACTIVE TEST" mode with CONSULT-II.
- Make sure that each circuit produces a momentary engine speed drop.

ACTIVE TEST	
POWER BALANCE	
MONITOR	
ENG SPEED	XXX rpm
MAS A/F SE-B1	XXX V

PBIB0133E

OK or NG

- OK >> **INSPECTION END**
- NG >> GO TO 7.

FUEL INJECTOR

3. CHECK FUNCTION OF FUEL INJECTOR-I

⊗ Without CONSULT-II

1. Stop engine.
 2. Disconnect harness connector F44 (2), F101 (3).
 3. Turn ignition switch ON.
- ⇐: Vehicle front
 - Intake manifold collector (1)

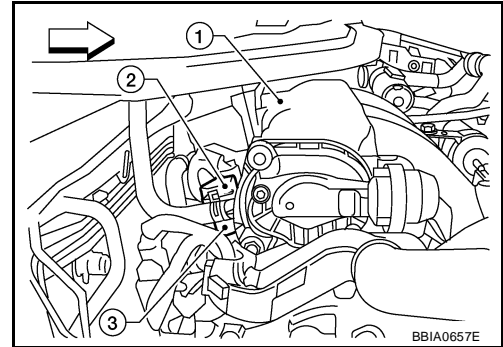

4. Check voltage between harness connector F44 terminal 5 and ground with CONSULT-II or tester.

Voltage: Battery voltage

5. Turn ignition switch OFF.
6. Disconnect ECM harness connector.
7. Check harness continuity between harness connector F44 terminal and ECM terminal as follows. Refer to Wiring Diagram.

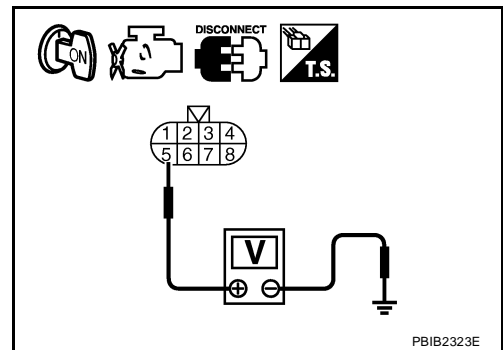

Cylinder	Harness connector F44 terminal	ECM terminal
1	6	23
3	2	22
5	1	21

Continuity should exist.

8. Also check harness for short to ground and short to power.

OK or NG

- OK >> GO TO 5.
- NG >> GO TO 4.

4. DETECT MALFUNCTIONING PART

Check the following.

- Harness connectors E8, F17
- Fuse block (J/B) connector E30
- 10A fuse
- Harness for open or short between harness connector F44 and fuse
- Harness for open or short between harness connector F44 and ECM

>> Repair open circuit or short to ground or short to power in harness or connectors.

FUEL INJECTOR

5. CHECK FUNCTION OF FUEL INJECTOR-II

Provide battery voltage between harness connector F101 as follows and then interrupt it. Listen to each fuel injector operating sound.

Cylinder	Harness connector F101 terminal	
	(+)	(-)
1	5	6
3	5	2
5	5	1

Operating sound should exist.

OK or NG

OK >> GO TO 6.

NG >> GO TO 7.

6. CHECK FUNCTION OF FUEL INJECTOR-III

1. Reconnect all harness connector disconnected.
2. Start engine.
3. Listen to fuel injectors No. 2, No. 4, No.6 operating sound.

Clicking noise should exist.

OK or NG

OK >> **INSPECTION END**

NG >> GO TO 7.

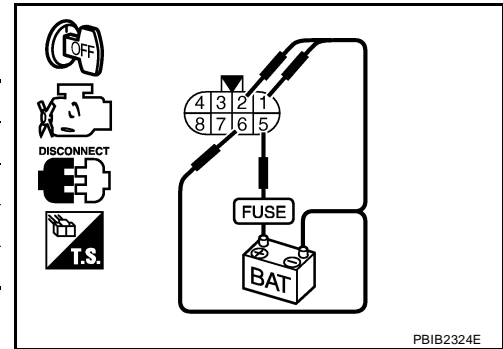

PBIB2324E

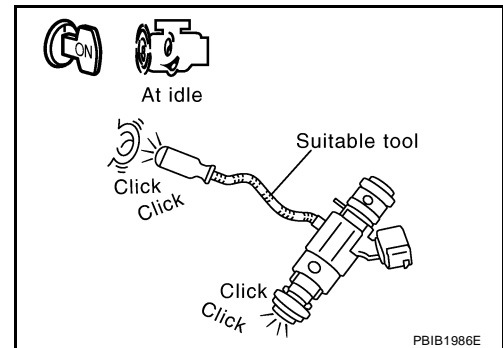

PBIB1986E

FUEL INJECTOR

7. CHECK FULE INJECTOR POWER SUPPLY CIRCUIT

1. Turn ignition switch OFF.
2. Disconnect fuel injector harness connector.

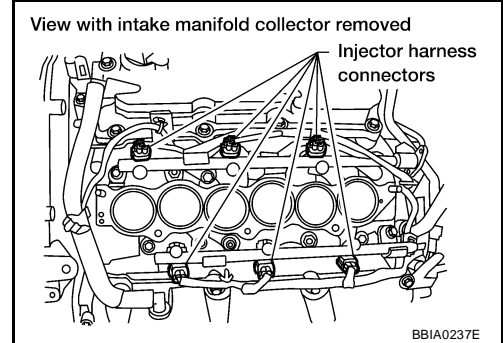

3. Turn ignition switch ON.
4. Check voltage between fuel injector terminal 1 and ground with CONSULT-II or tester.

Voltage: Battery voltage

OK or NG

- OK >> GO TO 9.
- NG >> GO TO 8.

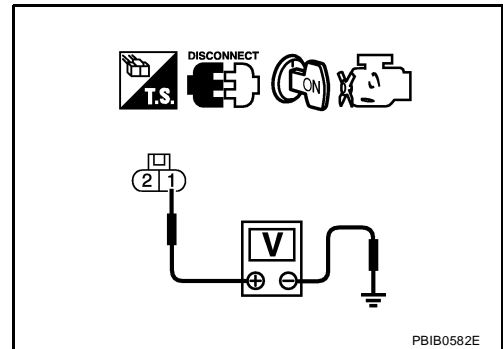

8. DETECT MALFUNCTIONING PART

Check the following.

- Harness connectors E8, F17
- Harness connectors F44, F101
- Fuse block (J/B) connector E30
- 10A fuse
- Harness for open or short between fuel injector and fuse

>> Repair harness or connectors.

9. CHECK FUEL INJECTOR OUTPUT SIGNAL CIRCUIT FOR OPEN AND SHORT

1. Turn ignition switch OFF.
2. Disconnect ECM harness connector.
3. Check harness continuity between fuel injector terminal 2 and ECM terminals 21, 22, 23, 40, 41, 42. Refer to Wiring Diagram.

Continuity should exist.

4. Also check harness for short to ground and short to power.

OK or NG

- OK >> GO TO 11.
- NG >> GO TO 10.

FUEL INJECTOR

10. DETECT MALFUNCTIONING PART

Check the following.

- Harness connectors F101, F44
- Harness for open or short between fuel injector and ECM

>> Repair open circuit or short to ground or short to power in harness or connectors.

11. CHECK FUEL INJECTOR

Refer to [EC-684, "Component Inspection"](#) .

OK or NG

OK >> GO TO 12.

NG >> Replace fuel injector.

12. CHECK INTERMITTENT INCIDENT

Refer to [EC-149, "TROUBLE DIAGNOSIS FOR INTERMITTENT INCIDENT"](#) .

>> INSPECTION END

Component Inspection FUEL INJECTOR

UBS00PG3

1. Disconnect fuel injector harness connector.
2. Check resistance between terminals as shown in the figure.

Resistance: 11.1 - 14.5Ω [at 10 - 60°C (50 - 140°F)]

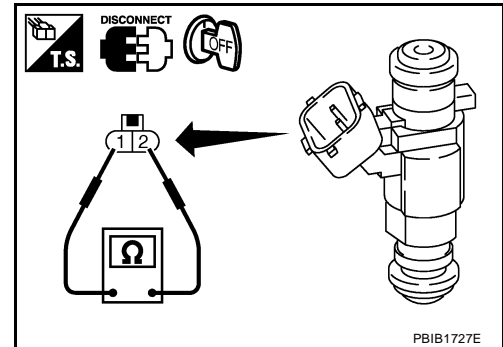

UBS00PG4

Removal and Installation FUEL INJECTOR

Refer to [EM-40, "FUEL INJECTOR AND FUEL TUBE"](#) .

FUEL PUMP

FUEL PUMP

PF1:17042

Description SYSTEM DESCRIPTION

UBS00PG5

Sensor	Input Signal to ECM	ECM Function	Actuator
Crankshaft position sensor (POS) Camshaft position sensor (PHASE)	Engine speed*	Fuel pump control	Fuel pump relay
Battery	Battery voltage*		

*: ECM determines the start signal status by the signals of engine speed and battery voltage.

The ECM activates the fuel pump for 1 second after the ignition switch is turned ON to improve engine startability. If the ECM receives a engine speed signal from the camshaft position sensor (PHASE), it knows that the engine is rotating, and causes the pump to operate. If the engine speed signal is not received when the ignition switch is ON, the engine stalls. The ECM stops pump operation and prevents battery discharging, thereby improving safety. The ECM does not directly drive the fuel pump. It controls the ON/OFF fuel pump relay, which in turn controls the fuel pump.

Condition	Fuel pump operation
Ignition switch is turned to ON.	Operates for 1 second.
Engine running and cranking	Operates.
When engine is stopped	Stops in 1.5 seconds.
Except as shown above	Stops.

COMPONENT DESCRIPTION

A turbine type design fuel pump is used in the fuel tank.

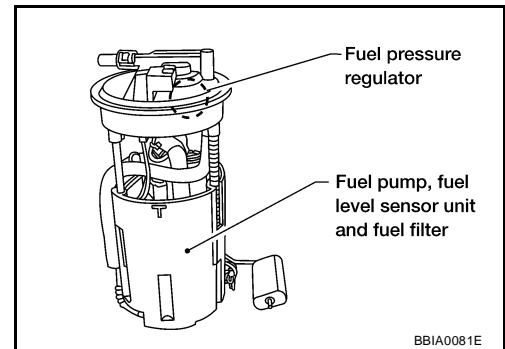

CONSULT-II Reference Value in Data Monitor Mode

UBS00PG6

Specification data are reference values.

MONITOR ITEM	CONDITION	SPECIFICATION
FUEL PUMP RLY	<ul style="list-style-type: none"> For 1 second after turning ignition switch ON Engine running or cranking 	ON
	<ul style="list-style-type: none"> Except above conditions 	OFF

FUEL PUMP

Wiring Diagram

UBS00PG7

EC-F/PUMP-01

: DETECTABLE LINE FOR DTC
 : NON-DETECTABLE LINE FOR DTC

REFER TO "PG-POWER".

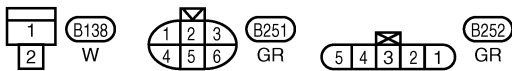
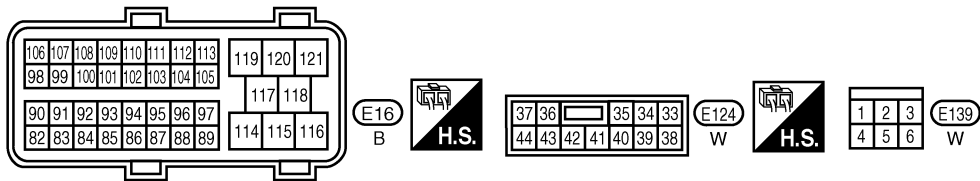
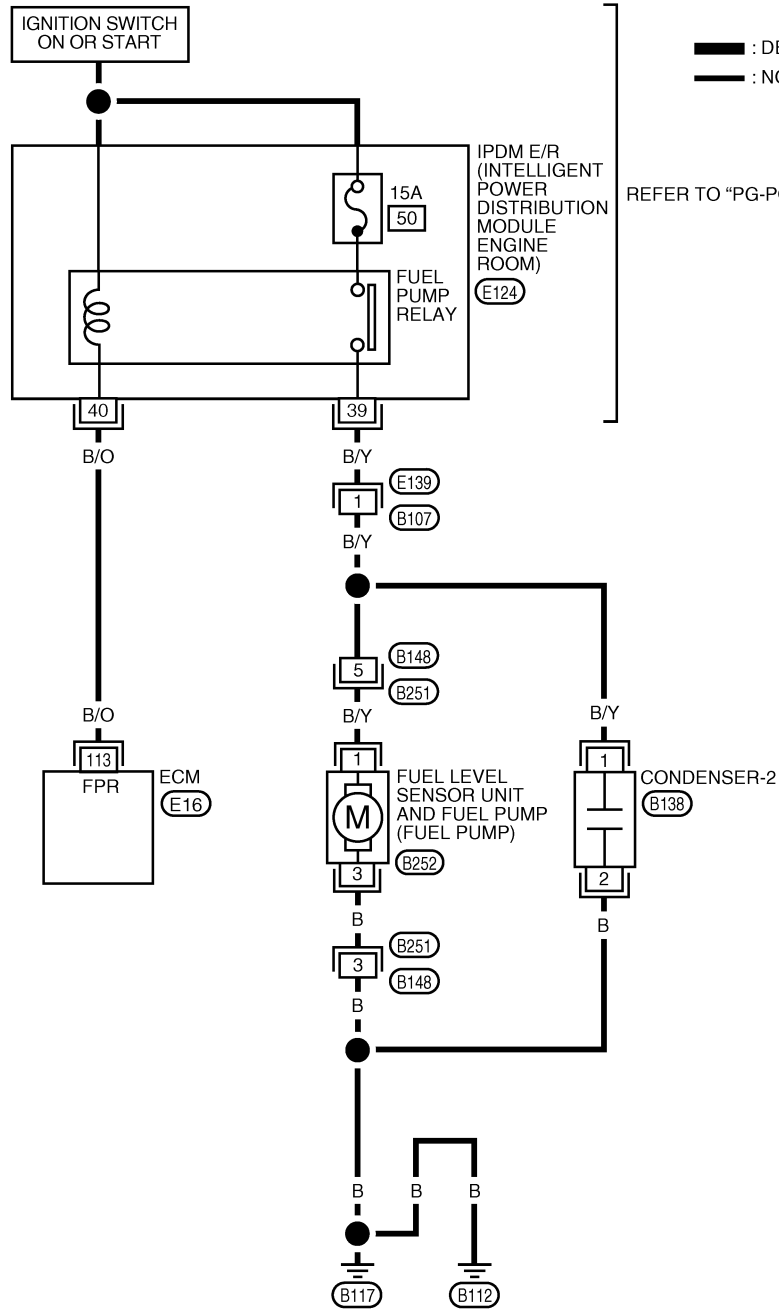

BBWA2540E

FUEL PUMP

Specification data are reference values and are measured between each terminal and ground.

CAUTION:

Do not use ECM ground terminals when measuring input/output voltage. Doing so may result in damage to the ECM's transistor. Use a ground other than ECM terminals, such as the ground.

TER-MINAL NO.	WIRE COLOR	ITEM	CONDITION	DATA (DC Voltage)
113	B/O	Fuel pump relay	[Ignition switch: ON] ● For 1 second after turning ignition switch ON	0 - 1.5V
			[Engine is running] [Ignition switch: ON] ● More than 1 second after turning ignition switch ON	BATTERY VOLTAGE (11 - 14V)

Diagnostic Procedure

UBS00PG8

1. CHECK OVERALL FUNCTION

1. Turn ignition switch ON.
2. Pinch fuel feed hose with two fingers.

Fuel pressure pulsation should be felt on the fuel feed hose for 1 second after ignition switch is turned ON.

OK or NG

- OK >> **INSPECTION END**
 NG >> GO TO 2.

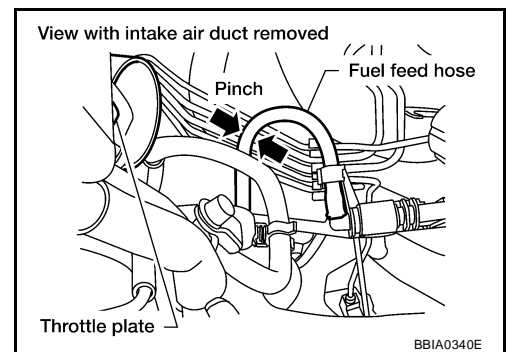

2. CHECK FUEL PUMP POWER SUPPLY CIRCUIT-I

1. Turn ignition switch OFF.
2. Disconnect ECM harness connector.
3. Turn ignition switch ON.
4. Check voltage between ECM terminal 113 and ground with CONSULT-II or tester.

Voltage: Battery voltage

OK or NG

- OK >> GO TO 4.
 NG >> GO TO 3.

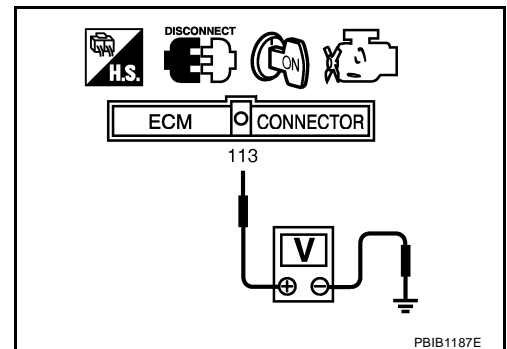

FUEL PUMP

3. CHECK FUEL PUMP POWER SUPPLY CIRCUIT-I

1. Turn ignition switch OFF.
2. Disconnect IPDM E/R harness connector E124.
3. Check harness continuity between IPDM E/R terminal 40 and ECM terminal 113.
Refer to Wiring Diagram.

Continuity should exist.

4. Also check harness for short to ground and short to power.

OK or NG

OK >> GO TO 13.

NG >> Repair open circuit or short to power or short to ground in harness or connectors.

4. CHECK CONDENSER-2 POWER SUPPLY CIRCUIT-I

1. Turn ignition switch OFF.
2. Reconnect all harness connectors disconnected.
3. Disconnect condenser-2 harness connector.
4. Turn ignition switch ON.
5. Check voltage between condenser-2 terminal 1 and ground with CONSULT-II or tester.

Voltage: Battery voltage should exist for 1 second after ignition switch is turned ON.

OK or NG

OK >> GO TO 8.

NG >> GO TO 5.

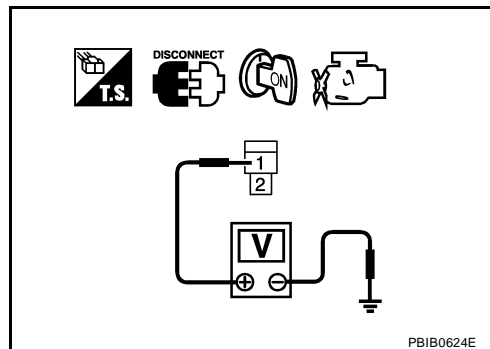

5. CHECK 15A FUSE

1. Turn ignition switch OFF.
2. Disconnect 15A fuse.
3. Check 15A fuse.

OK or NG

OK >> GO TO 6.

NG >> Replace fuse.

6. CHECK CONDENSER-2 POWER SUPPLY CIRCUIT-II

1. Disconnect IPDM E/R harness connector E124.
2. Check harness continuity between IPDM E/R terminal 39 and condenser-2 terminal 1.
Refer to Wiring Diagram.

Continuity should exist.

3. Also check harness for short to ground and short to power.

OK or NG

OK >> GO TO 13.

NG >> GO TO 7.

FUEL PUMP

7. DETECT MALFUNCTIONING PART

Check the following.

- Harness connectors B107, E139
- Harness for open or short between IPDM E/R and condenser-2

>> Repair harness or connectors.

8. CHECK CONDENSER-2 GROUND CIRCUIT FOR OPEN AND SHORT

1. Check harness continuity between condenser-2 terminal 2 and ground.
Refer to Wiring Diagram.

Continuity should exist.

2. Also check harness for short to power.

OK or NG

OK >> GO TO 9.

NG >> Repair open circuit or short to power in harness or connectors.

9. CHECK CONDENSER-2

Refer to [EC-690, "Component Inspection"](#).

OK or NG

OK >> GO TO 10.

NG >> Replace condenser-2.

10. CHECK FUEL PUMP POWER SUPPLY AND GROUND CIRCUIT FOR OPEN AND SHORT

1. Turn ignition switch OFF.
2. Disconnect "fuel level sensor unit and fuel pump" harness connector.
3. Disconnect harness connectors E139, B107
4. Check harness continuity between "fuel level sensor unit and fuel pump" terminal 1 and harness connector B107 terminal 1, "fuel level sensor unit and fuel pump" terminal 3 and ground.
Refer to Wiring Diagram.

Continuity should exist.

5. Also check harness for short to ground and short to power.

OK or NG

OK >> GO TO 12.

NG >> GO TO 11.

11. DETECT MALFUNCTIONING PART

Check the following.

- Harness connector B107
- Harness connectors B148, E251
- Harness for open or short between harness connector B107 and "fuel level sensor unit and fuel pump"
- Harness for open or short between "fuel level sensor unit and fuel pump" and ground

>> Repair harness or connectors.

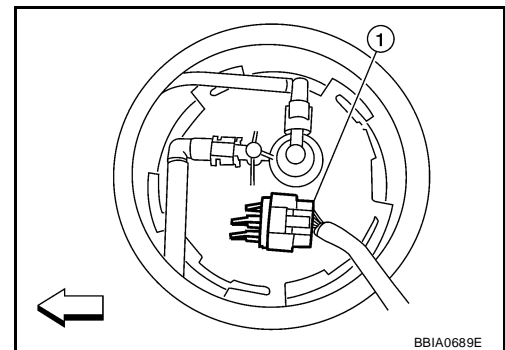

FUEL PUMP

12. CHECK FUEL PUPMP

Refer to [EC-690, "Component Inspection"](#) .

OK or NG

- OK >> GO TO 13.
- NG >> Replace "fuel level sensor unit and fuel pump".

13. CHECK INTERMITTENT INCIDENT

Refer to [EC-149, "TROUBLE DIAGNOSIS FOR INTERMITTENT INCIDENT"](#) .

OK or NG

- OK >> Replace IPDM E/R. Refer to [PG-18, "IPDM E/R \(INTELLIGENT POWER DISTRIBUTION MODULE ENGINE ROOM\)"](#) .
- NG >> Repair or replace harness or connectors.

Component Inspection FUEL PUMP

UBS00PG9

1. Disconnect "fuel level sensor unit and fuel pump" harness connector.
2. Check resistance between "fuel level sensor unit and fuel pump" terminals 1 and 3.

Resistance: Approximately 0.2 - 5.0Ω [at 25°C (77°F)]

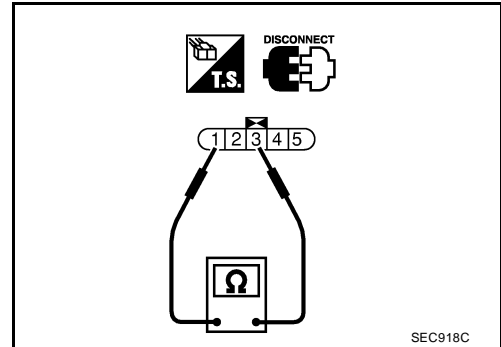

CONDENSER-2

1. Turn ignition switch OFF.
2. Disconnect condenser-2 harness connector.
3. Check resistance between condenser-2 terminals as 1 and 2.

Resistance: Above 1 MΩ [at 25°C (77°F)]

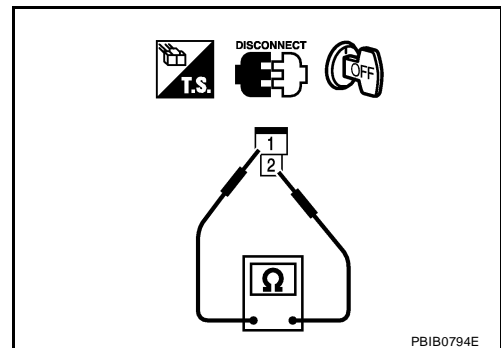

Removal and Installation FUEL PUMP

UBS00PGA

Refer to [FL-5, "FUEL LEVEL SENSOR UNIT, FUEL FILTER AND FUEL PUMP ASSEMBLY"](#) .

IGNITION SIGNAL

IGNITION SIGNAL

PF2:22448

Component Description

IGNITION COIL & POWER TRANSISTOR

UBS00PGB

The ignition signal from the ECM is sent to and amplified by the power transistor. The power transistor turns ON and OFF the ignition coil primary circuit. This ON/OFF operation induces the proper high voltage in the coil secondary circuit.

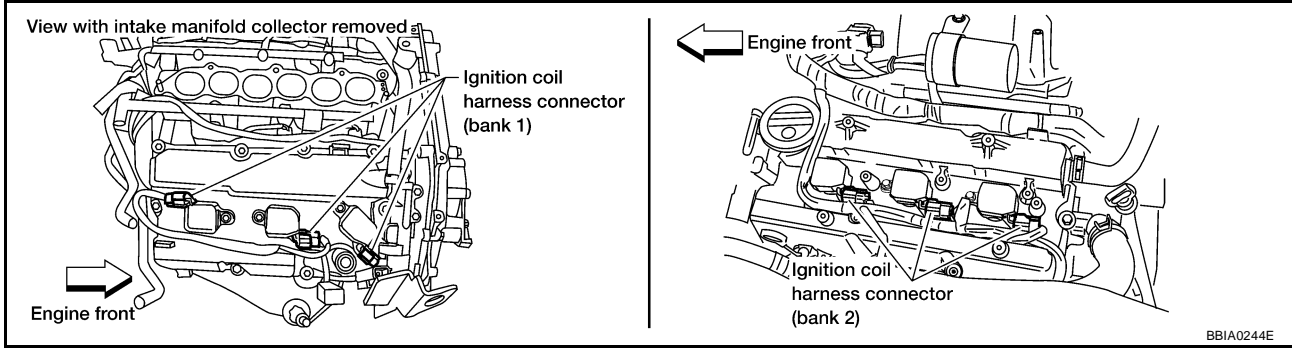

A

EC

C

D

E

F

G

H

I

J

K

L

M

IGNITION SIGNAL

Wiring Diagram

UBS00PGC

EC-IGNSYS-01

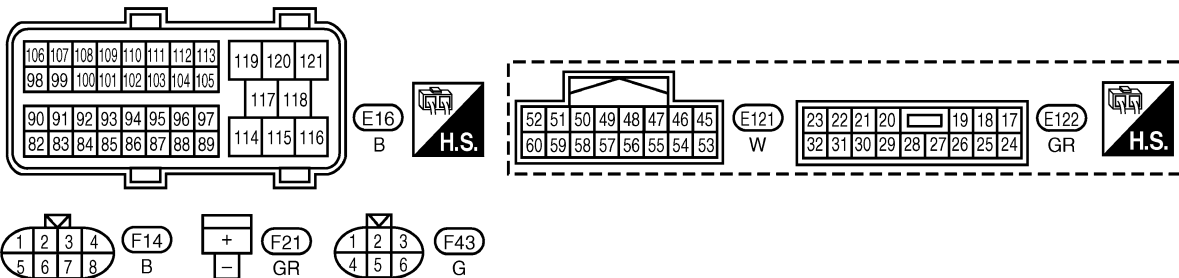
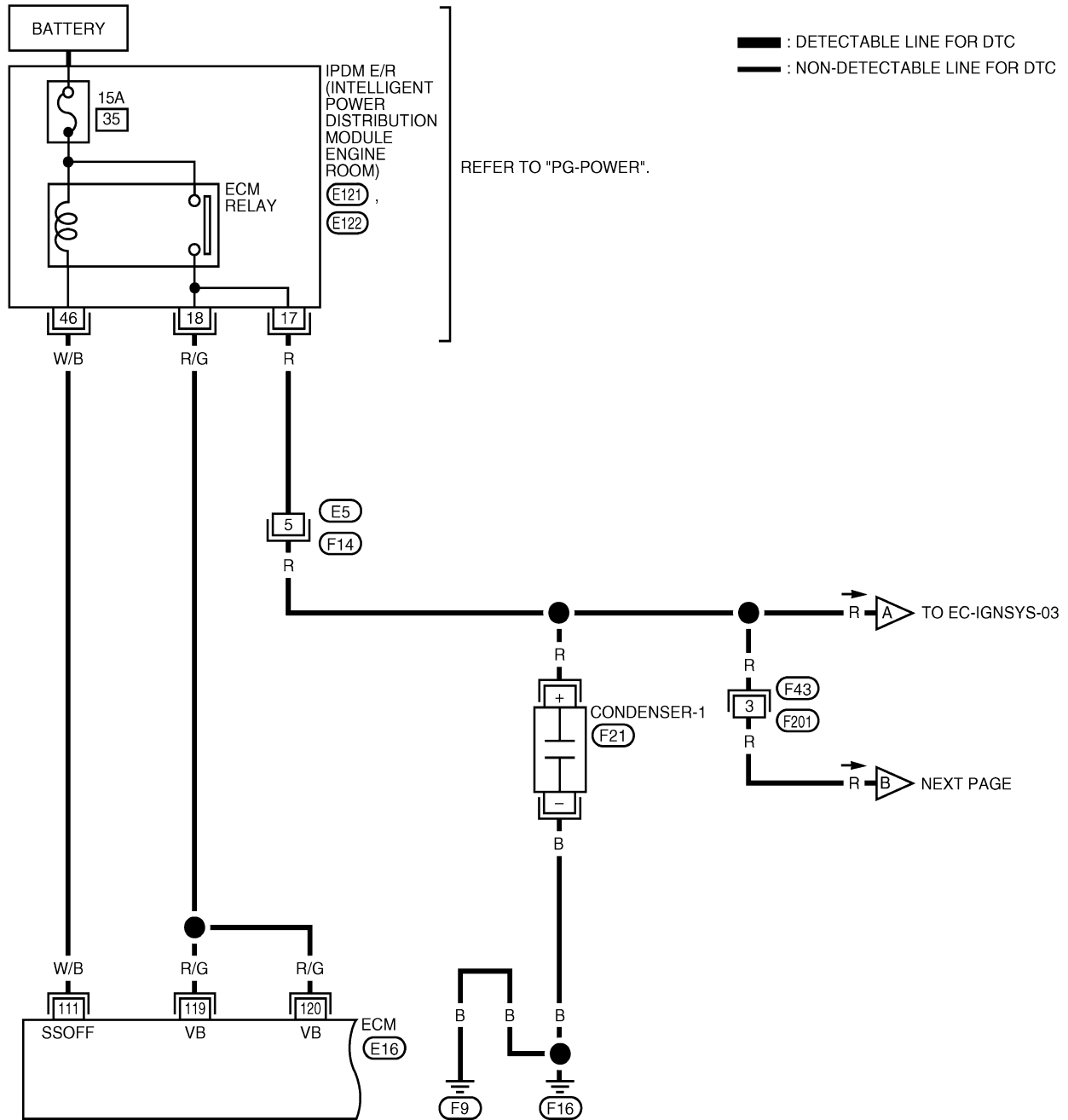

BBWA2535E

IGNITION SIGNAL

Specification data are reference values and are measured between each terminal and ground.

CAUTION:

Do not use ECM ground terminals when measuring input/output voltage. Doing so may result in damage to the ECM's transistor. Use a ground other than ECM terminals, such as the ground.

TER-MINAL NO.	WIRE COLOR	ITEM	CONDITION	DATA (DC Voltage)
111	W/B	ECM relay (Self shut-off)	[Engine is running] [Ignition switch: OFF] ● For a few seconds after turning ignition switch OFF	0 - 1.5V
			[Ignition switch: OFF] ● More than a few seconds after turning ignition switch OFF	BATTERY VOLTAGE (11 - 14V)
119 120	R/G R/G	Power supply for ECM	[Ignition switch: ON]	BATTERY VOLTAGE (11 - 14V)

A
EC
C
D
E
F
G
H
I
J
K
L
M

IGNITION SIGNAL

EC-IGNSYS-02

— : DETECTABLE LINE FOR DTC
 - - - : NON-DETECTABLE LINE FOR DTC

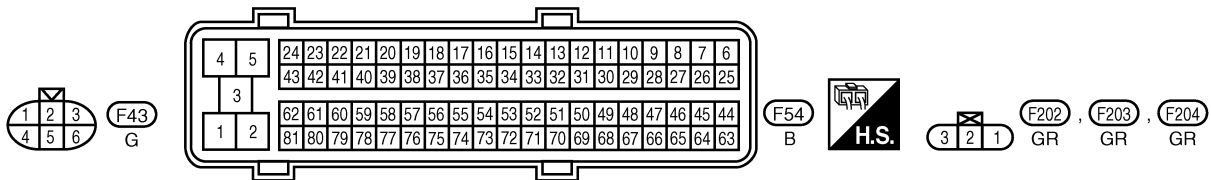
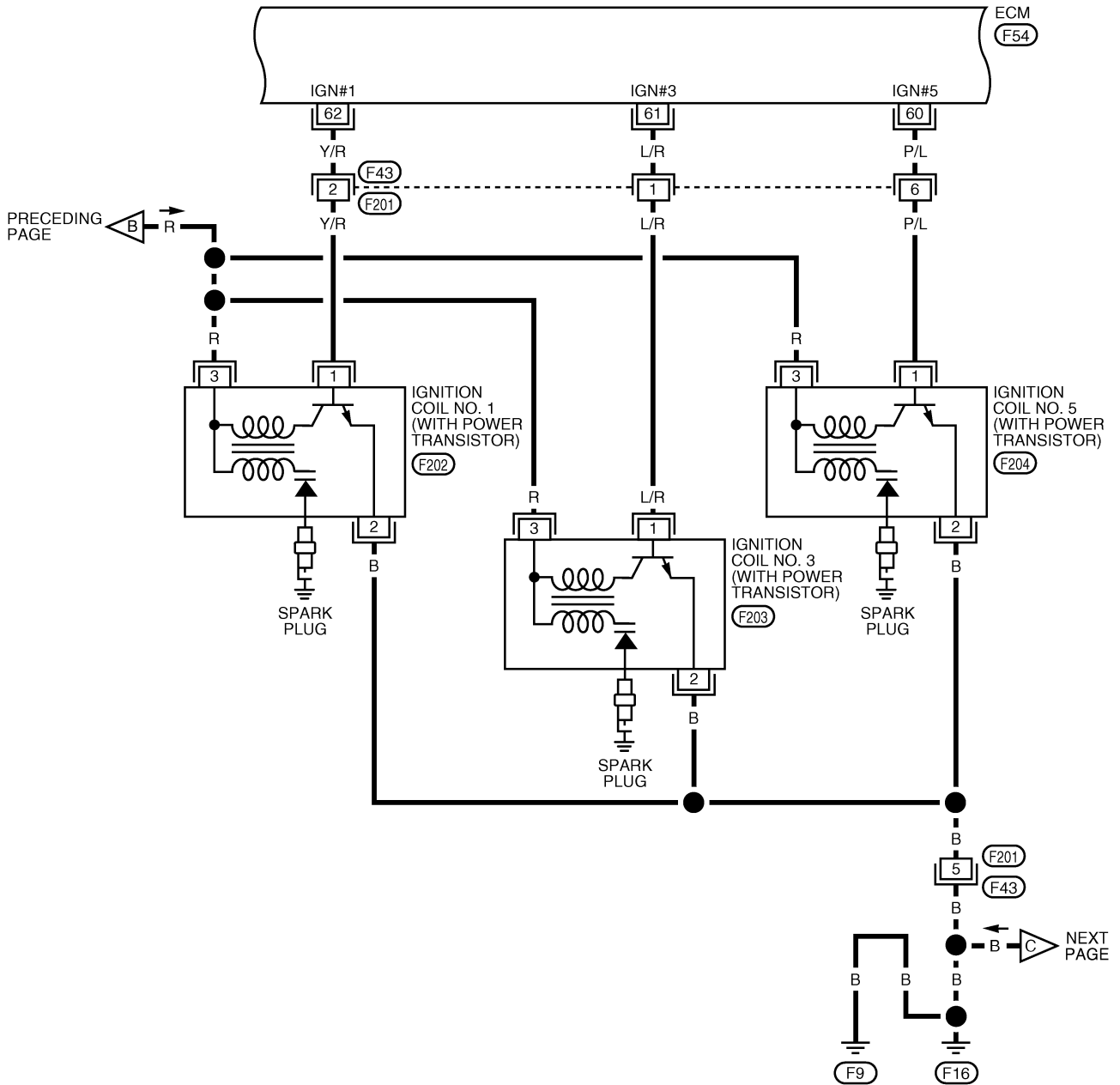

BBWA2536E

IGNITION SIGNAL

Specification data are reference values and are measured between each terminal and ground.
Pulse signal is measured by CONSULT-II.

CAUTION:

Do not use ECM ground terminals when measuring input/output voltage. Doing so may result in damage to the ECM's transistor. Use a ground other than ECM terminals, such as the ground.

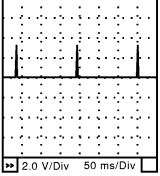
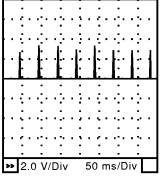
TER-MINAL NO.	WIRE COLOR	ITEM	CONDITION	DATA (DC Voltage)
60 61 62	P/L L/R Y/R	Ignition signal No. 5 Ignition signal No. 3 Ignition signal No. 1	<p>[Engine is running]</p> <ul style="list-style-type: none"> ● Warm-up condition ● Idle speed <p>NOTE: The pulse cycle changes depending on rpm at idle</p>	<p>0 - 0.4V★</p> 
			<p>[Engine is running]</p> <ul style="list-style-type: none"> ● Warm-up condition ● Engine speed: 2,500 rpm 	<p>0.1 - 0.6V★</p> 

★: Average voltage for pulse signal (Actual pulse signal can be confirmed by oscilloscope.)

IGNITION SIGNAL

EC-IGNSYS-03

: DETECTABLE LINE FOR DTC
 : NON-DETECTABLE LINE FOR DTC

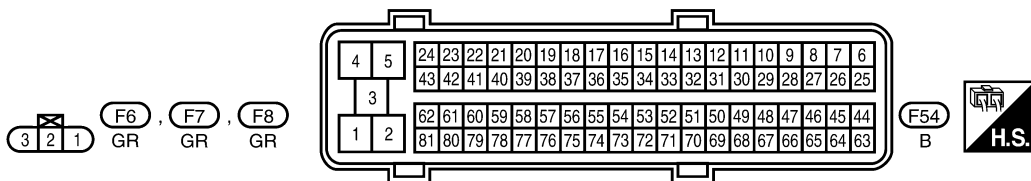
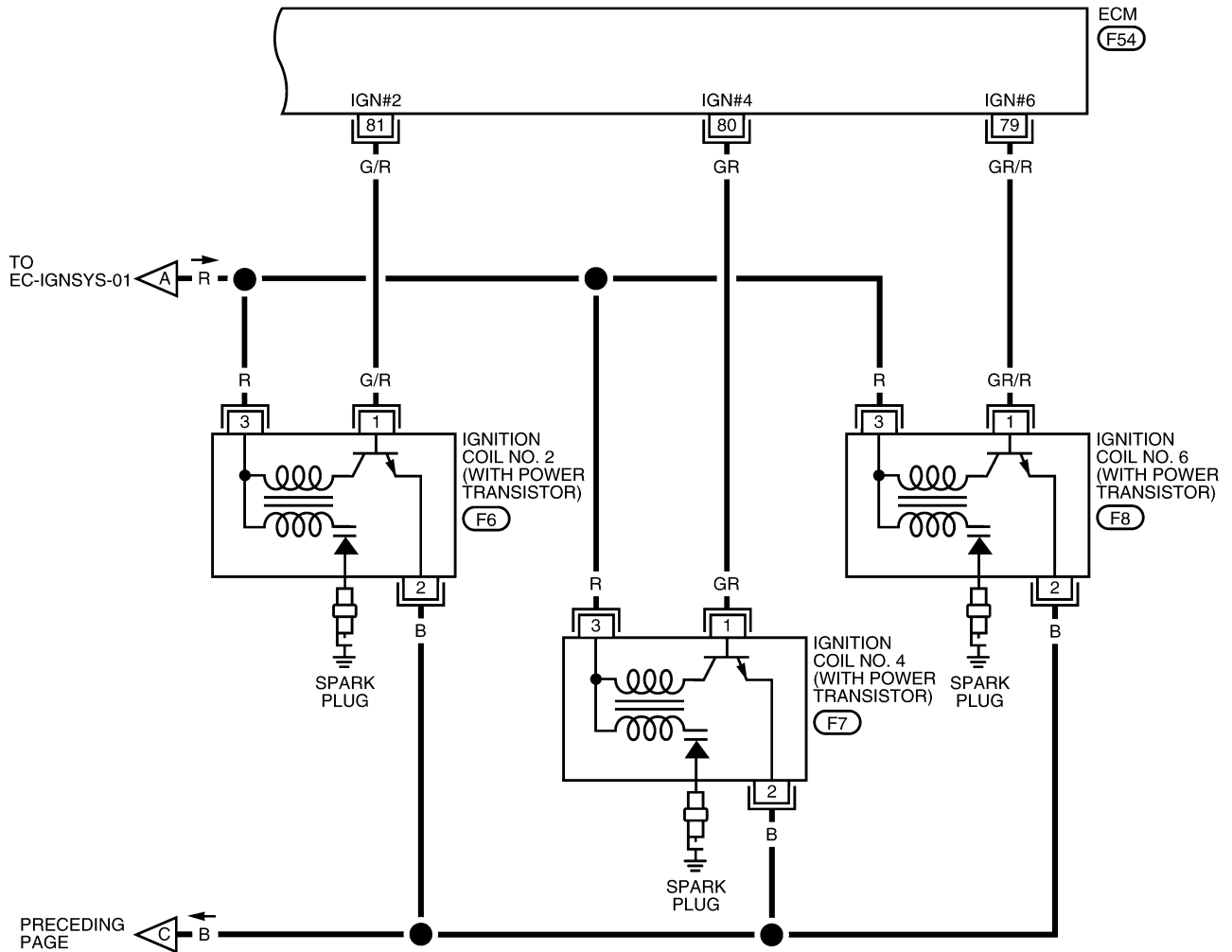

BBWA2537E

IGNITION SIGNAL

Specification data are reference values and are measured between each terminal and ground. Pulse signal is measured by CONSULT-II.

CAUTION:

Do not use ECM ground terminals when measuring input/output voltage. Doing so may result in damage to the ECM's transistor. Use a ground other than ECM terminals, such as the ground.

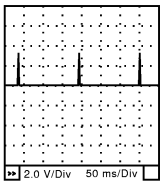
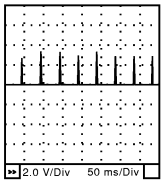
TER-MINAL NO.	WIRE COLOR	ITEM	CONDITION	DATA (DC Voltage)
79 80 81	GR/R GR G/R	Ignition signal No. 6 Ignition signal No. 4 Ignition signal No. 2	<p>[Engine is running]</p> <ul style="list-style-type: none"> ● Warm-up condition ● Idle speed <p>NOTE: The pulse cycle changes depending on rpm at idle</p>	<p>0 - 0.4V★</p> 
			<p>[Engine is running]</p> <ul style="list-style-type: none"> ● Warm-up condition ● Engine speed: 2,500 rpm 	<p>0.1 - 0.6V★</p> 

★: Average voltage for pulse signal (Actual pulse signal can be confirmed by oscilloscope.)

Diagnostic Procedure

1. CHECK ENGINE START

Turn ignition switch OFF, and restart engine.

Is engine running?

Yes or No

- Yes (With CONSULT-II)>>GO TO 2.
- Yes (Without CONSULT-II)>>GO TO 3.
- No >> GO TO 4.

2. CHECK OVERALL FUNCTION

With CONSULT-II

1. Perform "POWER BALANCE" in "ACTIVE TEST" mode with CONSULT-II.
2. Make sure that each circuit produces a momentary engine speed drop.

OK or NG

- OK >> **INSPECTION END**
- NG >> GO TO 10.

ACTIVE TEST	
POWER BALANCE	
MONITOR	
ENG SPEED	XXX rpm
MAS A/F SE-B1	XXX V

PBIB0133E

IGNITION SIGNAL

3. CHECK OVERALL FUNCTION

⊗ Without CONSULT-II

1. Let engine idle.
2. Read the voltage signal between ECM terminals 60, 61, 62, 79, 80, 81 and ground with an oscilloscope.
3. Verify that the oscilloscope screen shows the signal wave as shown below.

NOTE:

The pulse cycle changes depending on rpm at idle.

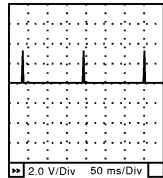

SEC986C

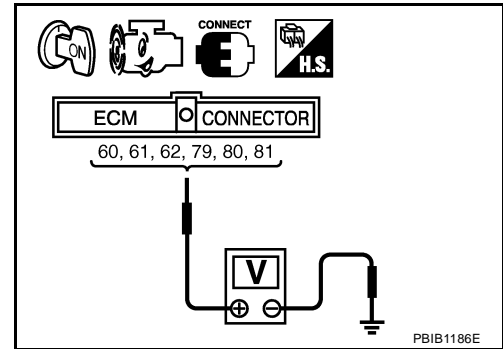

OK or NG

- OK >> **INSPECTION END**
NG >> GO TO 10.

4. CHECK IGNITION COIL POWER SUPPLY CIRCUIT-I

1. Turn ignition switch OFF, wait at least 10 seconds and then turn ON.
2. Check voltage between ECM terminals 119, 120 and ground with CONSULT-II or tester.

Voltage: Battery voltage

OK or NG

- OK >> GO TO 5.
NG >> Go to [EC-150, "POWER SUPPLY AND GROUND CIRCUIT"](#).

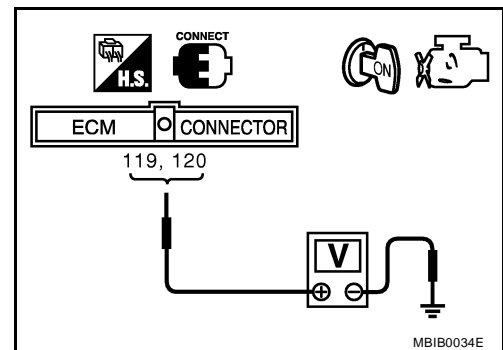

IGNITION SIGNAL

5. CHECK IGNITION COIL POWER SUPPLY CIRCUIT-II

1. Turn ignition switch OFF.
2. Disconnect condenser-1 harness connector.
3. Turn ignition switch ON.

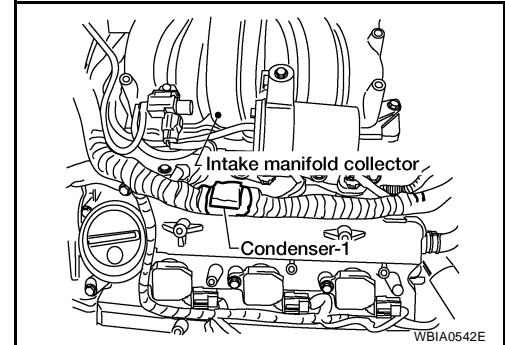

4. Check voltage between condenser-1 terminal + and ground with CONSULT-II or tester.

Voltage: Battery voltage

OK or NG

- OK >> GO TO 8.
- NG >> GO TO 6.

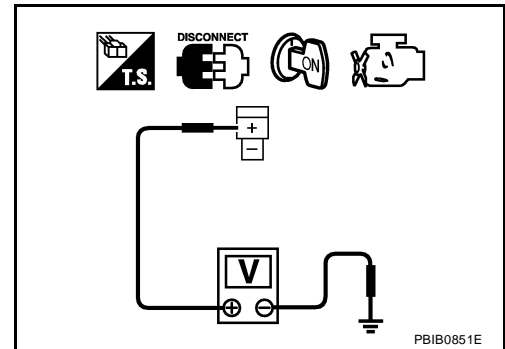

6. CHECK IGNITION COIL POWER SUPPLY CIRCUIT-III

1. Turn ignition switch OFF.
2. Disconnect IPDM E/R harness connector E122.
3. Check harness continuity between IPDM E/R terminal 17 and condenser-1 terminal +. Refer to Wiring Diagram.

Continuity should exist.

4. Also check harness for short to ground and short to power.

OK or NG

- OK >> Go to [EC-150, "POWER SUPPLY AND GROUND CIRCUIT"](#) .
- NG >> GO TO 7.

7. DETECT MALFUNCTIONING PART

Check the following.

- Harness connectors E5, F14
- Harness for open or short between IPDM E/R and condenser-1

>> Repair open circuit or short to ground or short to power in harness or connectors.

IGNITION SIGNAL

8. CHECK CONDENSER-1 GROUND CIRCUIT FOR OPEN AND SHORT

1. Turn ignition switch OFF.
2. Check harness continuity between condenser-1 terminal – and ground.
Refer to Wiring Diagram.

Continuity should exist.

3. Also check harness for short to power.

OK or NG

OK >> GO TO 9.

NG >> Repair open circuit or short to power in harness or connectors.

9. CHECK CONDENSER-1

Refer to [EC-702, "Component Inspection"](#) .

OK or NG

OK >> GO TO 10.

NG >> Replace condenser-1.

10. CHECK IGNITION COIL POWER SUPPLY CIRCUIT-V

1. Turn ignition switch OFF.
2. Reconnect all harness connectors disconnected.
3. Disconnect ignition coil harness connector.

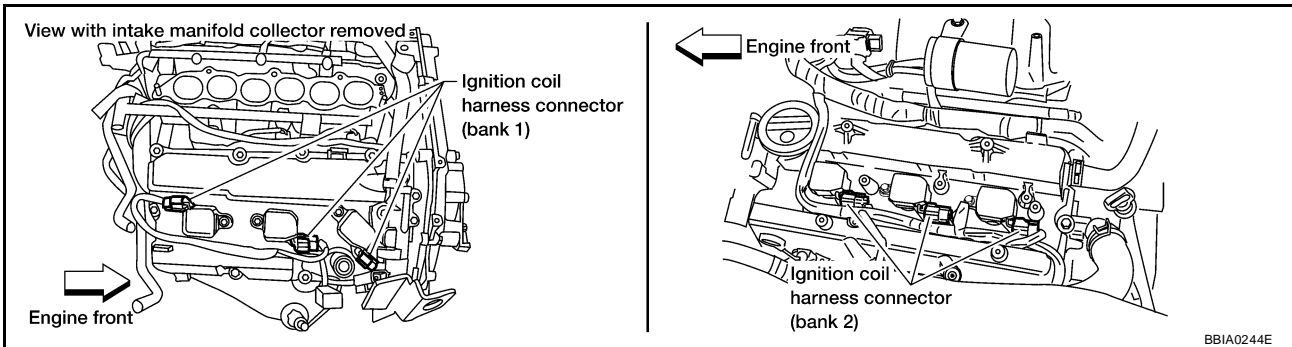

4. Turn ignition switch ON.
5. Check voltage between ignition coil terminal 3 and ground with CONSULT-II or tester.

Voltage: Battery voltage

OK or NG

OK >> GO TO 12.

NG >> GO TO 11.

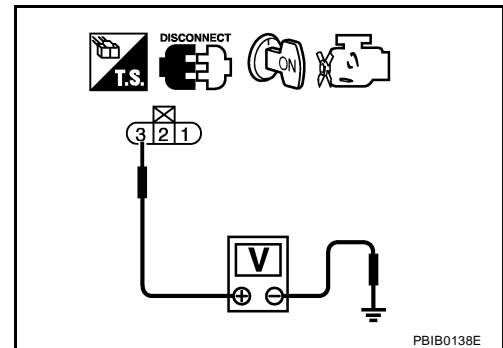

11. DETECT MALFUNCTIONING PART

Check the following.

- Harness connectors F43, F201
- Harness for open or short between ignition coil and harness connector F14

>> Repair or replace harness or connectors.

IGNITION SIGNAL

12. CHECK IGNITION COIL GROUND CIRCUIT FOR OPEN AND SHORT

1. Turn ignition switch OFF.
2. Check harness continuity between ignition coil terminal 2 and ground.
Refer to Wiring Diagram.

Continuity should exist.

3. Also check harness for short to power.

OK or NG

- OK >> GO TO 14.
- NG >> GO TO 13.

13. DETECT MALFUNCTIONING PART

Check the following.

- Harness connectors F201, F43
- Harness for open or short between ignition coil and ground

>> Repair open circuit or short to power in harness or connectors.

14. CHECK IGNITION COIL OUTPUT SIGNAL CIRCUIT FOR OPEN AND SHORT

1. Disconnect ECM harness connector.
2. Check harness continuity between ECM terminals 60, 61, 62, 79, 80, 81 and ignition coil terminal 1.
Refer to Wiring Diagram.

Continuity should exist.

3. Also check harness for short to ground and short to power.

OK or NG

- OK >> GO TO 16.
- NG >> GO TO 15.

15. DETECT MALFUNCTIONING PART

Check the following.

- Harness connectors F43, F201
- Harness for open or short between ignition coil and ECM

>> Repair open circuit or short to ground or short to power in harness or connectors.

16. CHECK IGNITION COIL WITH POWER TRANSISTOR

Refer to [EC-702, "Component Inspection"](#) .

OK or NG

- OK >> GO TO 17.
- NG >> Replace malfunctioning ignition coil with power transistor.

17. CHECK INTERMITTENT INCIDENT

Refer to [EC-149, "TROUBLE DIAGNOSIS FOR INTERMITTENT INCIDENT"](#) .

>> **INSPECTION END**

IGNITION SIGNAL

UBS00PGE

Component Inspection IGNITION COIL WITH POWER TRANSISTOR

CAUTION:

Do the following procedure in the place where ventilation is good without the combustible.

1. Turn ignition switch OFF.
2. Disconnect ignition coil harness connector.
3. Check resistance between ignition coil terminals as follows.

Terminal No. (Polarity)	Resistance Ω [at 25°C (77°F)]
1 and 2	Except 0 or ∞
1 and 3	Except 0
2 and 3	

4. If NG, Replace ignition coil with power transistor.
If OK, go to next step.
5. Turn ignition switch OFF.
6. Reconnect all harness connectors disconnected.
7. Remove fuel pump fuse in IPDM E/R to release fuel pressure.

NOTE:

Do not use CONSULT-II to release fuel pressure, or fuel pressure applies again during the following procedure.

8. Start engine.
9. After engine stalls, crank it two or three times to release all fuel pressure.
10. Turn ignition switch OFF.
11. Remove ignition coil harness connectors to avoid the electrical discharge from the ignition coils.
12. Remove ignition coil and spark plug of the cylinder to be checked.
13. Crank engine for 5 seconds or more to remove combustion gas in the cylinder.
14. Connect spark plug and harness connector to ignition coil.
15. Fix ignition coil using a rope etc. with gap of 13 - 17 mm between the edge of the spark plug and grounded metal portion as shown in the figure.
16. Crank engine for about 3 seconds, and check whether spark is generated between the spark plug and the grounded part.

Spark should be generated.

CAUTION:

- Do not approach to the spark plug and the ignition coil within 50cm. Be careful not to get an electrical shock while checking, because the electrical discharge voltage becomes 20kV or more.

- It might cause to damage the ignition coil if the gap of more than 17 mm is taken.

NOTE:

When the gap is less than 13 mm, the spark might be generated even if the coil is malfunctioning.

17. If NG, Replace ignition coil with power transistor.

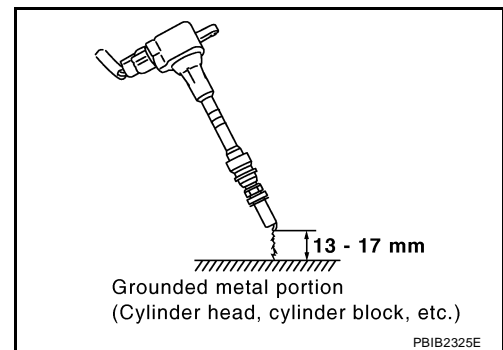
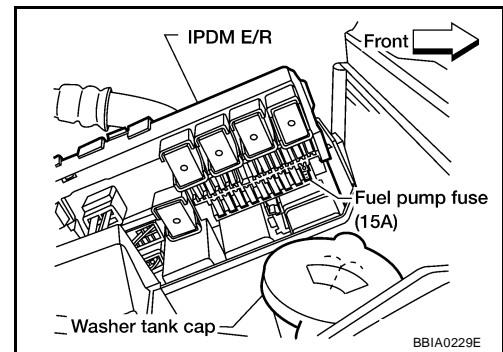
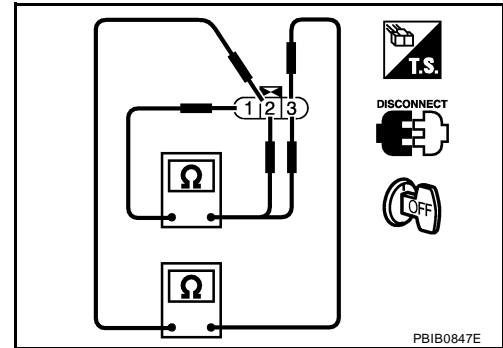

IGNITION SIGNAL

CONDENSER-1

1. Turn ignition switch OFF.
2. Disconnect condenser-1 harness connector.
3. Check resistance between condenser-1 terminals + and -.

Resistance: Above 1 M Ω [at 25°C (77°F)]

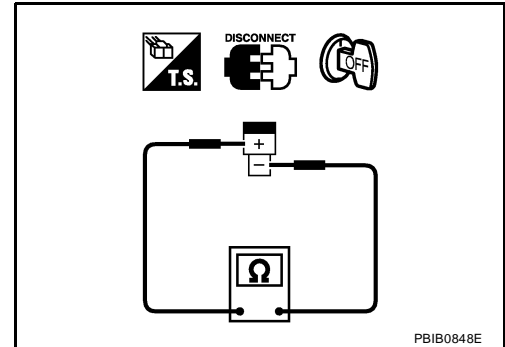

UBS00PGF

Removal and Installation IGNITION COIL WITH POWER TRANSISTOR

Refer to [EM-36, "IGNITION COIL"](#) .

A

EC

C

D

E

F

G

H

I

J

K

L

M

REFRIGERANT PRESSURE SENSOR

PF9:92136

REFRIGERANT PRESSURE SENSOR

Component Description

UBS00PGG

The refrigerant pressure sensor is installed in the RH side of the condenser of the air conditioner system. The sensor uses an electrostatic volume pressure transducer to convert refrigerant pressure to voltage. The voltage signal is sent to ECM, and ECM controls cooling fan system.

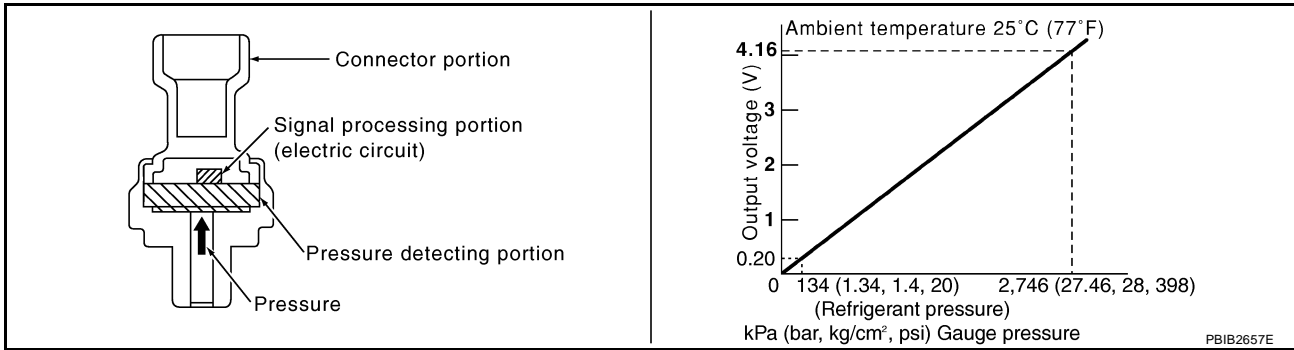
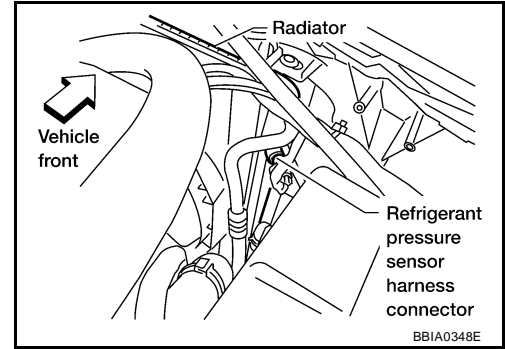

REFRIGERANT PRESSURE SENSOR

Wiring Diagram

UBS00PGH

EC-RP/SEN-01

: DETECTABLE LINE FOR DTC
 : NON-DETECTABLE LINE FOR DTC

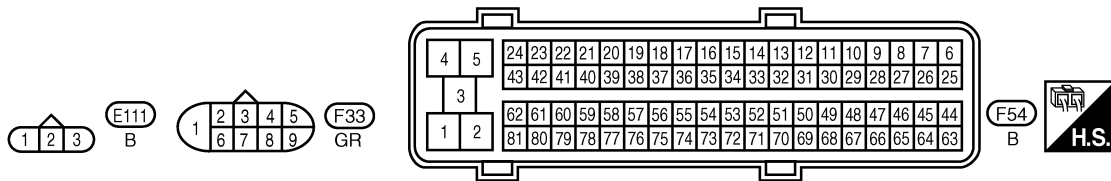
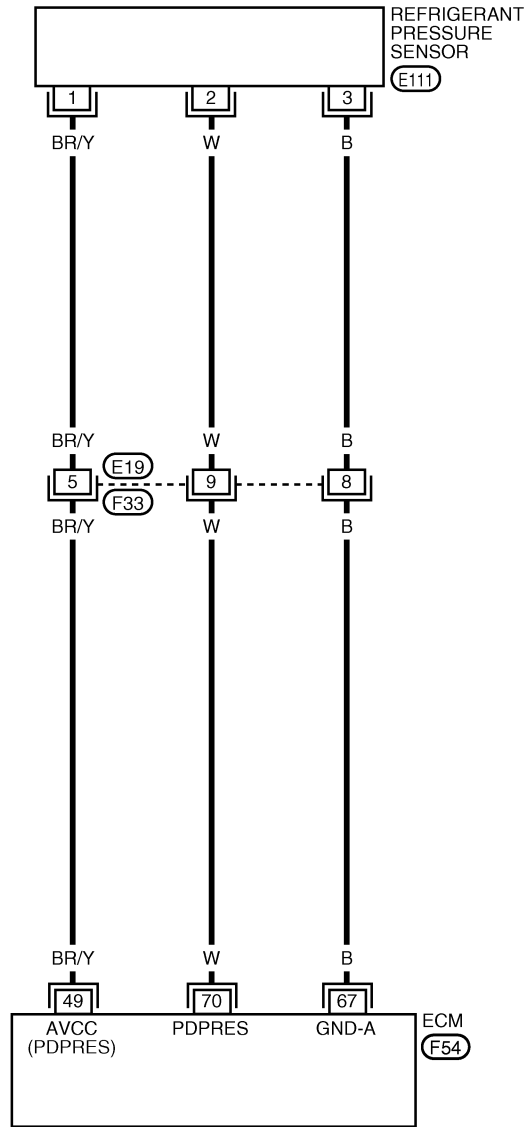

BBWA2541E

REFRIGERANT PRESSURE SENSOR

Specification data are reference values and are measured between each terminal and ground.

CAUTION:

Do not use ECM ground terminals when measuring input/output voltage. Doing so may result in damage to the ECM's transistor. Use a ground other than ECM terminals, such as the ground.

TER-MINAL NO.	WIRE COLOR	ITEM	CONDITION	DATA (DC Voltage)
49	BR/Y	Refrigerant pressure sensor power supply	[Ignition switch: ON]	Approximately 5V
67	B	Sensor ground	[Engine is running] ● Warm-up condition ● Idle speed	Approximately 0V
70	W	Refrigerant pressure sensor	[Engine is running] ● Warm-up condition ● Both A/C switch and blower fan switch: ON (Compressor operates.)	1.0 - 4.0V

Diagnostic Procedure

UBS00PGI

1. CHECK REFRIGERANT PRESSURE SENSOR OVERALL FUNCTION

1. Start engine and warm it up to normal operating temperature.
2. Turn A/C switch and blower fan switch ON.
3. Check voltage between ECM terminal 70 and ground with CONSULT-II or tester.

Voltage: 1.0 - 4.0V

OK or NG

- OK >> **INSPECTION END**
- NG >> GO TO 2.

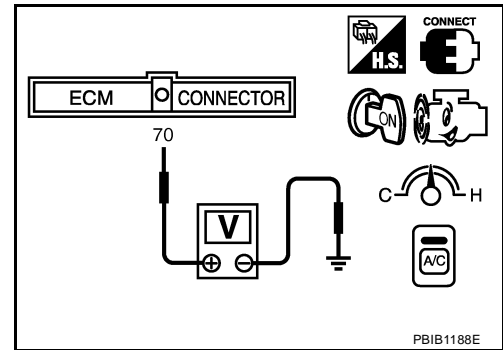

PBIB1188E

REFRIGERANT PRESSURE SENSOR

2. CHECK GROUND CONNECTIONS

1. Stop engine.
2. Turn A/C switch and blower fan switch OFF
3. Loosen and retighten three ground screws on the body. Refer to [EC-158, "Ground Inspection"](#) .

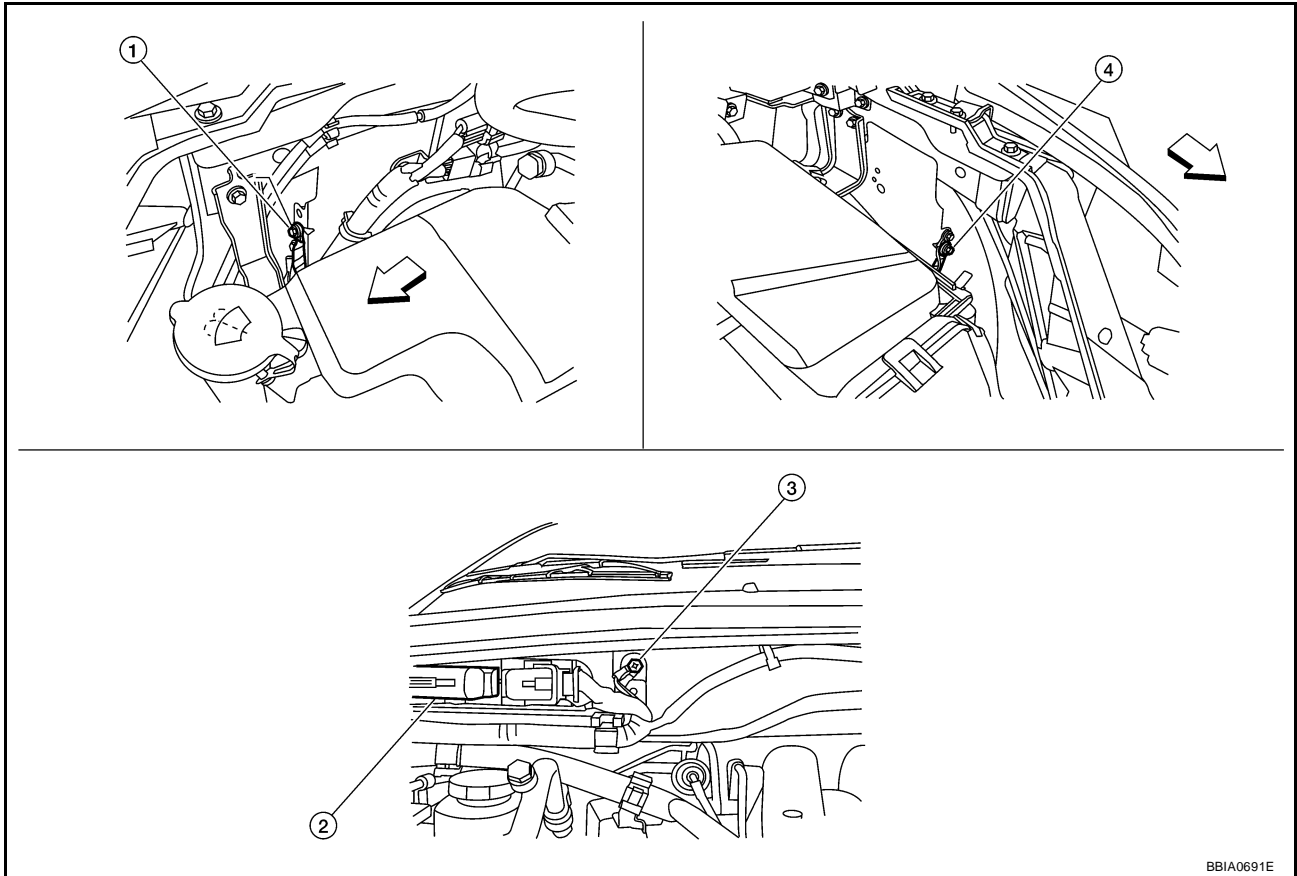

← Vehicle front

1. Body ground E24

2. ECM

3. Body ground E9

4. Body ground E15

OK or NG

OK >> GO TO 3.

NG >> Repair or replace ground connections.

REFRIGERANT PRESSURE SENSOR

3. CHECK REFRIGERANT PRESSURE SENSOR POWER SUPPLY CIRCUIT

1. Disconnect refrigerant pressure sensor harness connector.
2. Turn ignition switch ON.

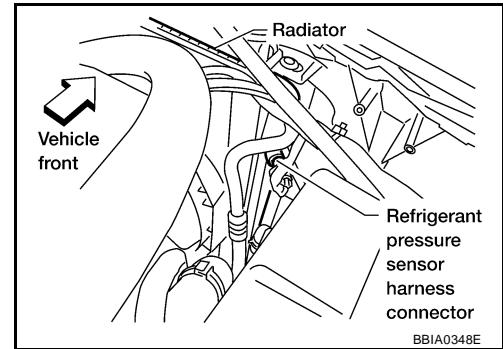

3. Check voltage between refrigerant pressure sensor terminal 1 and ground with CONSULT-II or tester.

Voltage: Approximately 5V

OK or NG

- OK >> GO TO 5.
- NG >> GO TO 4.

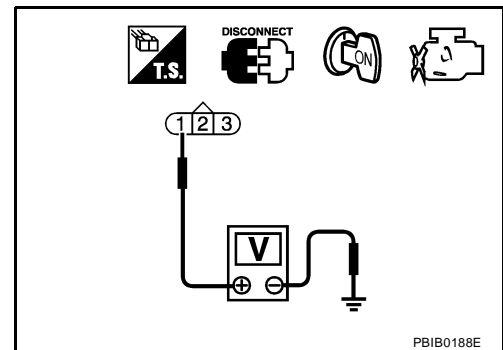

4. DETECT MALFUNCTIONING PART

Check the following.

- Harness connectors E19, F33
- Harness for open or short between ECM and refrigerant pressure sensor

>> Repair harness or connectors.

5. CHECK REFRIGERANT PRESSURE SENSOR GROUND CIRCUIT FOR OPEN AND SHORT

1. Turn ignition switch OFF.
2. Disconnect ECM harness connector.
3. Check harness continuity between refrigerant pressure sensor terminal 3 and ECM terminal 67. Refer to Wiring Diagram.

Continuity should exist.

4. Also check harness for short to ground and short to power.

OK or NG

- OK >> GO TO 7.
- NG >> GO TO 6.

6. DETECT MALFUNCTIONING PART

Check the following.

- Harness connectors E19, F33
- Harness for open or short between ECM and refrigerant pressure sensor

>> Repair open circuit or short to ground or short to power in harness or connectors.

REFRIGERANT PRESSURE SENSOR

7. CHECK REFRIGERANT PRESSURE SENSOR INPUT SIGNAL CIRCUIT FOR OPEN AND SHORT

1. Check harness continuity between ECM terminal 70 and refrigerant pressure sensor terminal 2.
Refer to Wiring Diagram.

Continuity should exist.

2. Also check harness for short to ground and short to power.

OK or NG

- OK >> GO TO 9.
NG >> GO TO 8.

8. DETECT MALFUNCTIONING PART

Check the following.

- Harness connectors E19, F33
- Harness for open or short between ECM and refrigerant pressure sensor

>> Repair open circuit or short to ground or short to power in harness or connectors.

9. CHECK INTERMITTENT INCIDENT

Refer to [EC-149, "TROUBLE DIAGNOSIS FOR INTERMITTENT INCIDENT"](#) .

OK or NG

- OK >> Replace refrigerant pressure sensor.
NG >> Repair or replace.

Removal and Installation REFRIGERANT PRESSURE SENSOR

UBS00PGJ

Refer to [ATC-206, "Removal and Installation for Refrigerant Pressure Sensor"](#) or [MTC-184, "Removal and Installation for Refrigerant Pressure Sensor"](#) .

VIAS

Description SYSTEM DESCRIPTION

UBS00PGK

Sensor	Input Signal to ECM	ECM function	Actuator
Crankshaft position sensor (POS) Camshaft position sensor (PHASE)	Engine speed*	VIAS control	VIAS control solenoid valve
Mass air flow sensor	Amount of intake air		
Engine coolant temperature sensor	Engine coolant temperature		
Throttle position sensor	Throttle position		
Accelerator pedal position sensor	Accelerator pedal position		
Battery	Battery voltage*		

*: ECM determines the start signal status by the signals of engine speed and battery voltage.

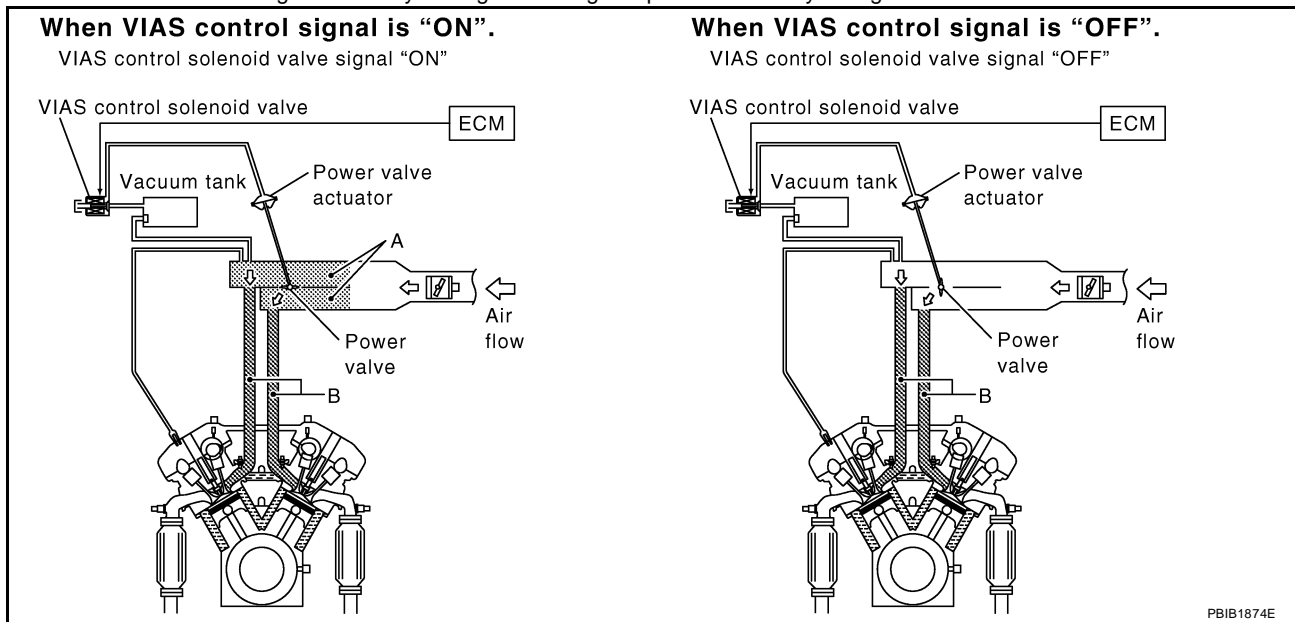

When the engine is running at low or medium speed, the power valve is fully closed. Under this condition, the effective suction port length is equivalent to the total length of the intake manifold collector's suction port including the intake valve. This long suction port provides increased air intake which results in improved suction efficiency and higher torque generation.

The surge tank and one-way valve are provided. When engine is running at high speed, the ECM sends the signal to the VIAS control solenoid valve. This signal introduces the intake manifold vacuum into the power valve actuator and therefore opens the power valve to two suction passages together in the collector.

Under this condition, the effective port length is equivalent to the length of the suction port provided independently for each cylinder. This shortened port length results in enhanced engine output with reduced suction resistance under high speeds.

COMPONENT DESCRIPTION

Power Valve

The power valve is installed in intake manifold collector and used to control the suction passage of the variable induction air control system. It is set in the fully closed or fully opened position by the power valve actuator (1) operated by the vacuum stored in the surge tank. The vacuum in the surge tank is controlled by the VIAS control solenoid valve (2).

- ⇐: Vehicle front

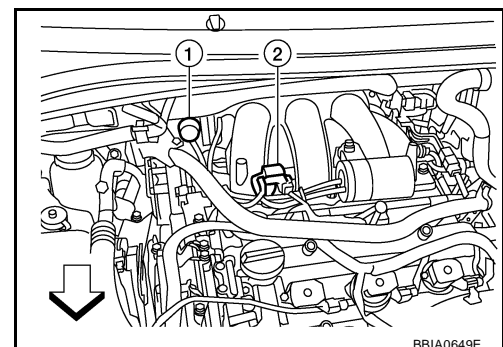

VIAS

VIAS Control Solenoid Valve

The VIAS control solenoid valve (2) cuts the intake manifold vacuum signal for power valve control. It responds to ON/OFF signals from the ECM. When the solenoid is off, the vacuum signal from the intake manifold is cut. When the ECM sends an ON signal the coil pulls the plunger downward and feeds the vacuum signal to the power valve actuator (1).

- ↵: Vehicle front

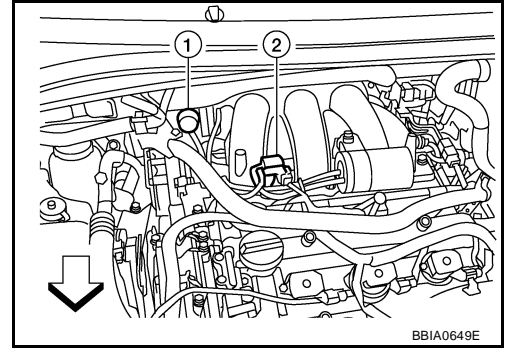

CONSULT-II Reference Value in Data Monitor Mode

UBS00PGL

Specification data are reference values.

MONITOR ITEM	CONDITION	SPECIFICATION	
VIAS S/V	● Engine: After warming up	1,800 - 3,600 rpm	ON
		Except above conditions	OFF

VIAS

Wiring Diagram

UBS00PGM

EC-VIAS-01

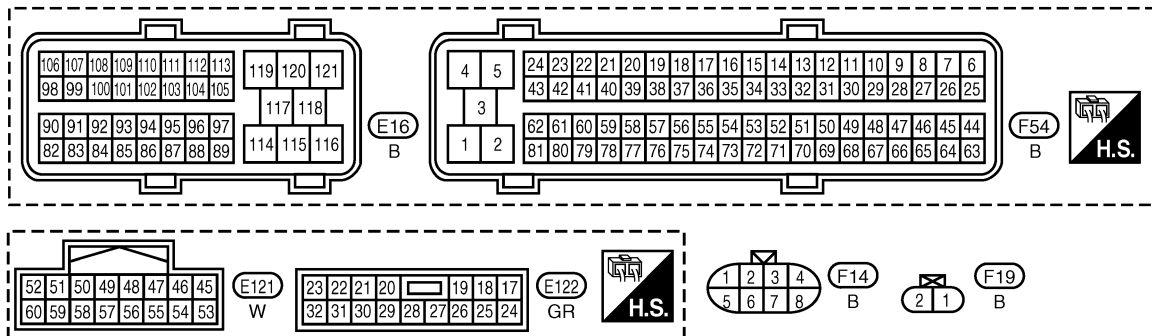
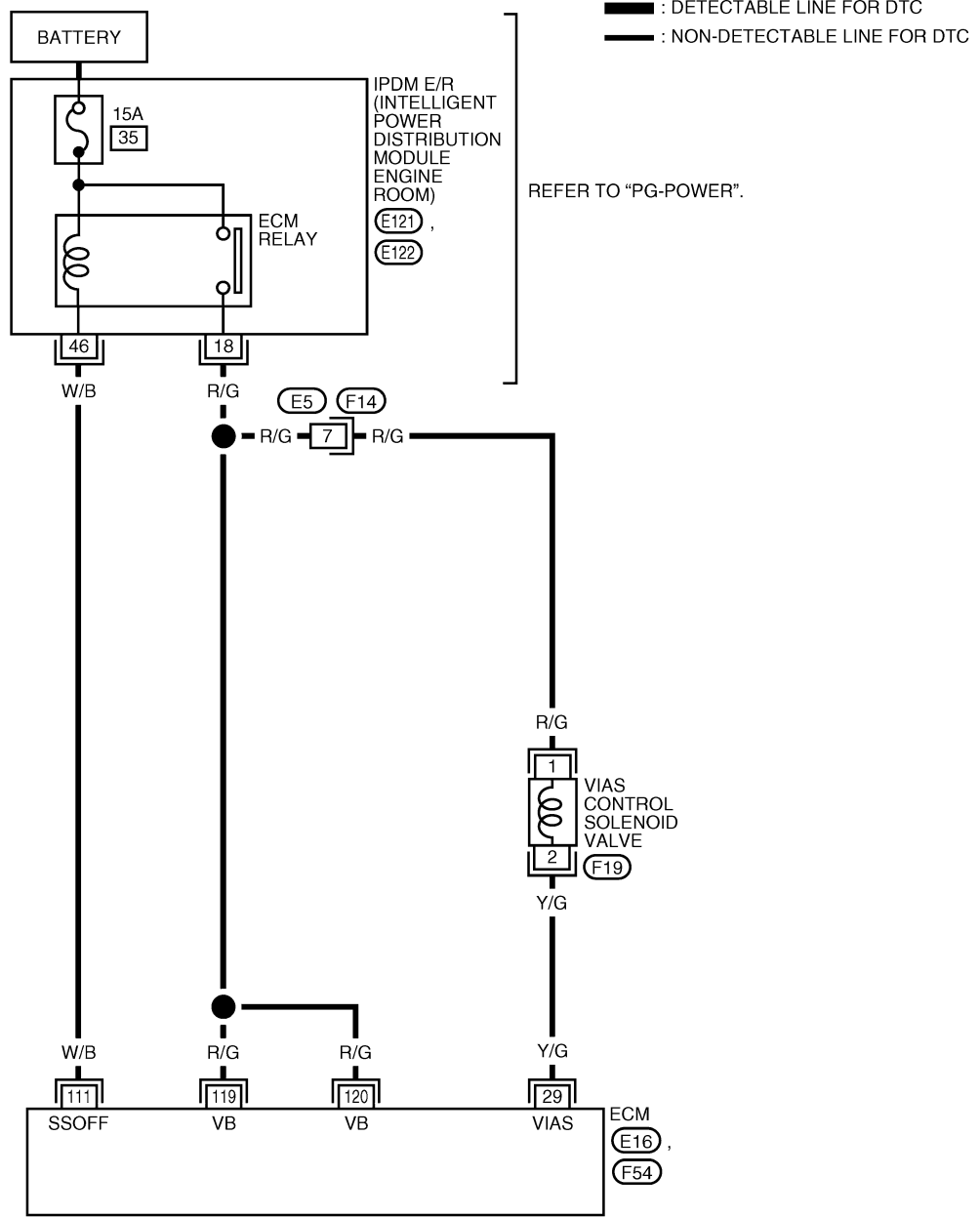

BBWA2538E

VIAS

Specification data are reference values and are measured between each terminal and ground.

CAUTION:

Do not use ECM ground terminals when measuring input/output voltage. Doing so may result in damage to the ECM's transistor. Use a ground other than ECM terminals, such as the ground.

TER-MINAL NO.	WIRE COLOR	ITEM	CONDITION	DATA (DC Voltage)
29	Y/G	VIAS control solenoid valve	[Engine is running] ● Idle speed	BATTERY VOLTAGE (11 - 14V)
			[Engine is running] ● Engine speed: Between 1,800 and 3,600 rpm	0 - 1.0V
111	W/B	ECM relay (Self shut-off)	[Engine is running] [Ignition switch: OFF] ● For a few seconds after turning ignition switch OFF	0 - 1.5V
			[Ignition switch: OFF] ● More than a few seconds passed after turning ignition switch OFF	BATTERY VOLTAGE (11 - 14V)
119 120	R/G R/G	Power supply for ECM	[Ignition switch: ON]	BATTERY VOLTAGE (11 - 14V)

A
EC
C
D
E
F
G
H
I
J
K
L
M

VIAS

UBS00PGN

Diagnostic Procedure

1. CHECK OVERALL FUNCTION

With CONSULT-II

1. Start engine and warm it up to normal operating temperature.
2. Perform "VIAS SOL VALVE" in "ACTIVE TEST" mode with CONSULT-II.
3. Turn VIAS control solenoid valve ON and OFF, and make sure that power valve actuator rod moves as shown in the figure.

NOTE:

Use an inspection mirror (A) to confirm the operation of power valve actuator rod.

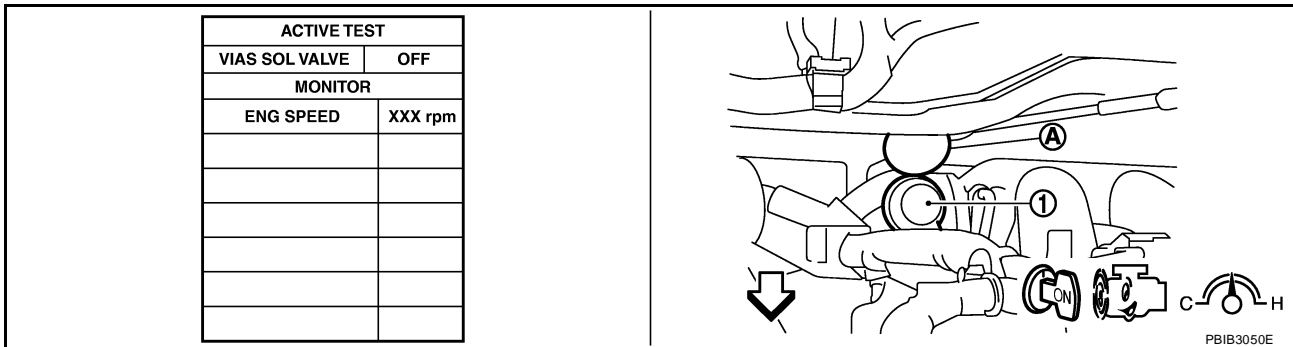

↔ Vehicle front

1. Power valve actuator

Without CONSULT-II

1. Start engine and warm it up to normal operating temperature.
2. Rev engine up to between 1,800 and 3,600 rpm and make sure that power valve actuator rod moves as shown in the figure.

NOTE:

Use an inspection mirror (A) to confirm the operation of power valve actuator rod.

- ↔ Vehicle front
- Power valve actuator (1)

OK or NG

OK >> **INSPECTION END**

NG (With CONSULT-II) >>GO TO 2.

NG (Without CONSULT-II) >>GO TO 3.

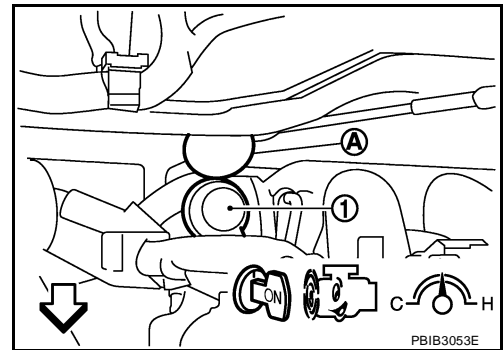

VIAS

2. CHECK VACUUM EXISTENCE

With CONSULT-II

1. Stop engine and disconnect vacuum hose connected to power valve actuator.
2. Install the vacuum gauge as shown in the figure.
3. Start engine and let it idle.
4. Perform "VIAS SOL VALVE" in "ACTIVE TEST" mode with CONSULT-II.
5. Turn VIAS control solenoid valve ON and OFF, and check vacuum existence under the following conditions.



← Vehicle front

1. Power valve actuator
2. Vacuum gauge
3. VIAS control solenoid valve

VIAS SOL VALVE	Vacuum
ON	Should exist
OFF	Should not exist

OK or NG

- OK >> Repair or replace power valve actuator.
- NG >> GO TO 4.

VIAS

3. CHECK VACUUM EXISTENCE

⊗ Without CONSULT-II

1. Stop engine and disconnect vacuum hose connected to power valve actuator.
2. Install the vacuum gauge as shown in the figure.
3. Disconnect VIAS control solenoid valve harness connector.
4. Start engine and let it idle.
5. Apply 12V of direct current between VIAS control solenoid valve terminals 1 and 2.



← Vehicle front

1. Power valve actuator
2. Vacuum gauge
3. VIAS control solenoid valve

6. Check vacuum existence under the following conditions.

Condition	Vacuum
12V direct current supply	Should exist
No supply	Should not exist

OK or NG

- OK >> Repair or replace power valve actuator.
 NG >> GO TO 4.

4. CHECK VACUUM HOSE

1. Stop engine.
2. Check hoses and tubes between intake manifold and power valve actuator for crack, clogging, improper connection or disconnection. Refer to [EC-106, "Vacuum Hose Drawing"](#).

OK or NG

- OK >> GO TO 5.
 NG >> Repair hoses or tubes.

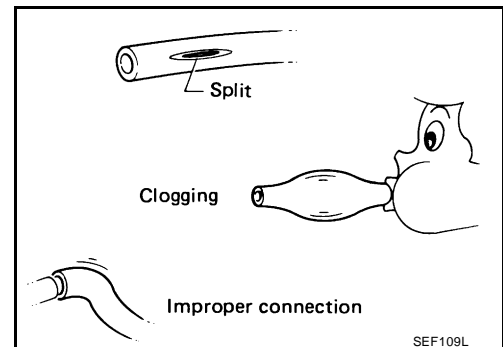

5. CHECK VACUUM TANK

Refer to [EC-718, "Component Inspection"](#).

OK or NG

- OK >> GO TO 6.
 NG >> Replace vacuum tank.

VIAS

6. CHECK VIAS CONTROL SOLENOID VALVE POWER SUPPLY CIRCUIT

1. Turn ignition switch OFF.
2. Disconnect VIAS control solenoid valve (2) harness connector.
3. Turn ignition switch ON.
 - ⇐: Vehicle front
 - Power valve actuator (1)

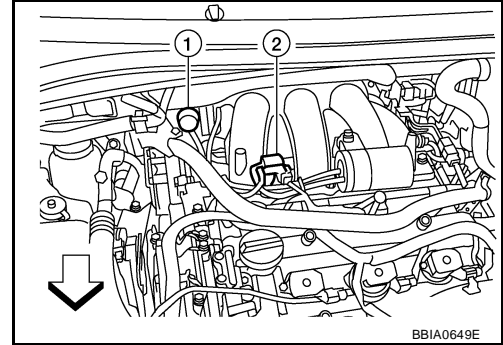

4. Check voltage between VIAS control solenoid valve terminal 1 and ground with CONSULT-II or tester.

Voltage: Battery voltage

OK or NG

- OK >> GO TO 8.
- NG >> GO TO 7.

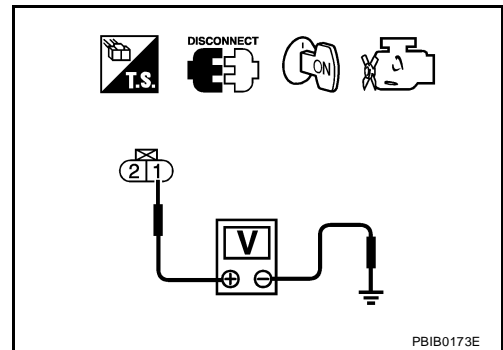

7. DETECT MALFUNCTIONING PART

Check the following.

- Harness connectors E5, F14
- Harness for open or short between VIAS control solenoid valve and IPDM E/R
- Harness for open or short between VIAS control solenoid valve and ECM

>> Repair harness or connectors.

8. CHECK VIAS CONTROL SOLENOID VALVE OUTPUT SIGNAL CIRCUIT FOR OPEN AND SHORT

1. Turn ignition switch OFF.
2. Disconnect ECM harness connector.
3. Check harness continuity between ECM terminal 29 and VIAS control solenoid valve terminal 2. Refer to Wiring Diagram.

Continuity should exist.

4. Also check harness for short to ground and short to power.

OK or NG

- OK >> GO TO 9.
- NG >> Repair open circuit or short to ground or short to power in harness or connectors.

9. CHECK VIAS CONTROL SOLENOID VALVE

Refer to [EC-718, "Component Inspection"](#) .

OK or NG

- OK >> GO TO 10.
- NG >> Replace VIAS control solenoid valve.

10. CHECK INTERMITTENT INCIDENT

Refer to [EC-149, "TROUBLE DIAGNOSIS FOR INTERMITTENT INCIDENT"](#) .

>> INSPECTION END

Component Inspection VIAS CONTROL SOLENOID VALVE

UBS00PGO

🔧 With CONSULT-II

1. Reconnect harness connectors disconnected.
2. Turn ignition switch ON.
3. Perform "VIAS SOL VALVE" in "ACTIVE TEST" mode.
4. Check air passage continuity and operation delay time under the following conditions.

Condition VIAS SOL VALVE	Air passage continuity between A and B	Air passage continuity between A and C	
ON	Yes	No	
OFF	No	Yes	

Operation takes less than 1 second.

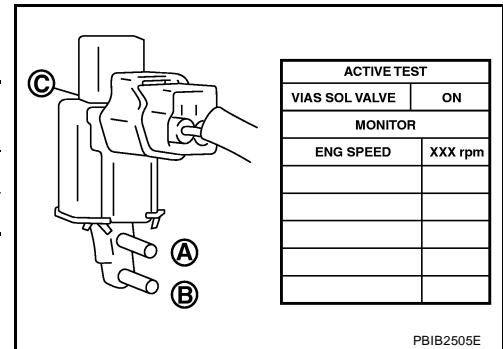

⊗ Without CONSULT-II

Check air passage continuity and operation delay time under the following conditions.

Condition	Air passage continuity between A and B	Air passage continuity between A and C	
12V direct current supply between terminals 1 and 2	Yes	No	
No supply	No	Yes	

Operation takes less than 1 second.

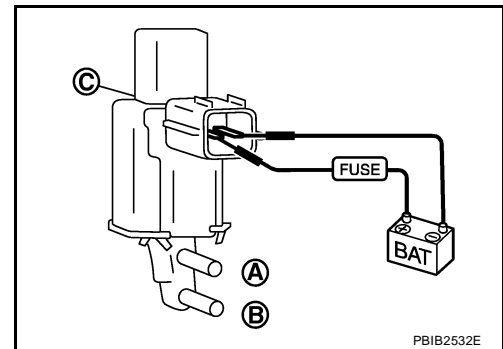

VACUUM TANK

1. Disconnect vacuum hose connected to vacuum tank.
2. Connect a vacuum pump to the center port of vacuum tank.
3. Apply vacuum and make sure that vacuum exists at the other port.

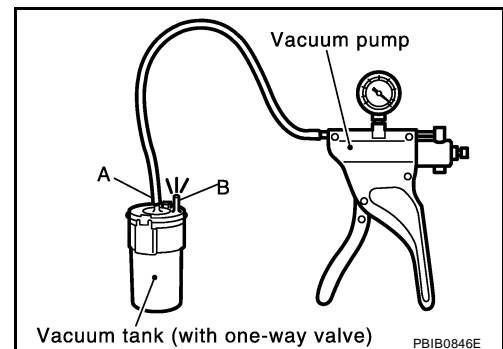

Removal and Installation VIAS CONTROL SOLENOID VALVE

UBS00PGP

Refer to [EM-24, "INTAKE MANIFOLD"](#) .

MIL AND DATA LINK CONNECTOR



PF24814

UBS00PGQ

MIL AND DATA LINK CONNECTOR

Wiring Diagram

EC-MIL/DL-01

-  : DETECTABLE LINE FOR DTC
-  : NON-DETECTABLE LINE FOR DTC
-  : DATA LINE

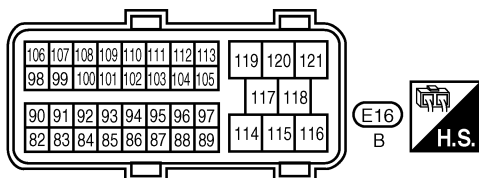
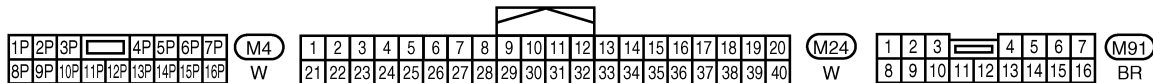
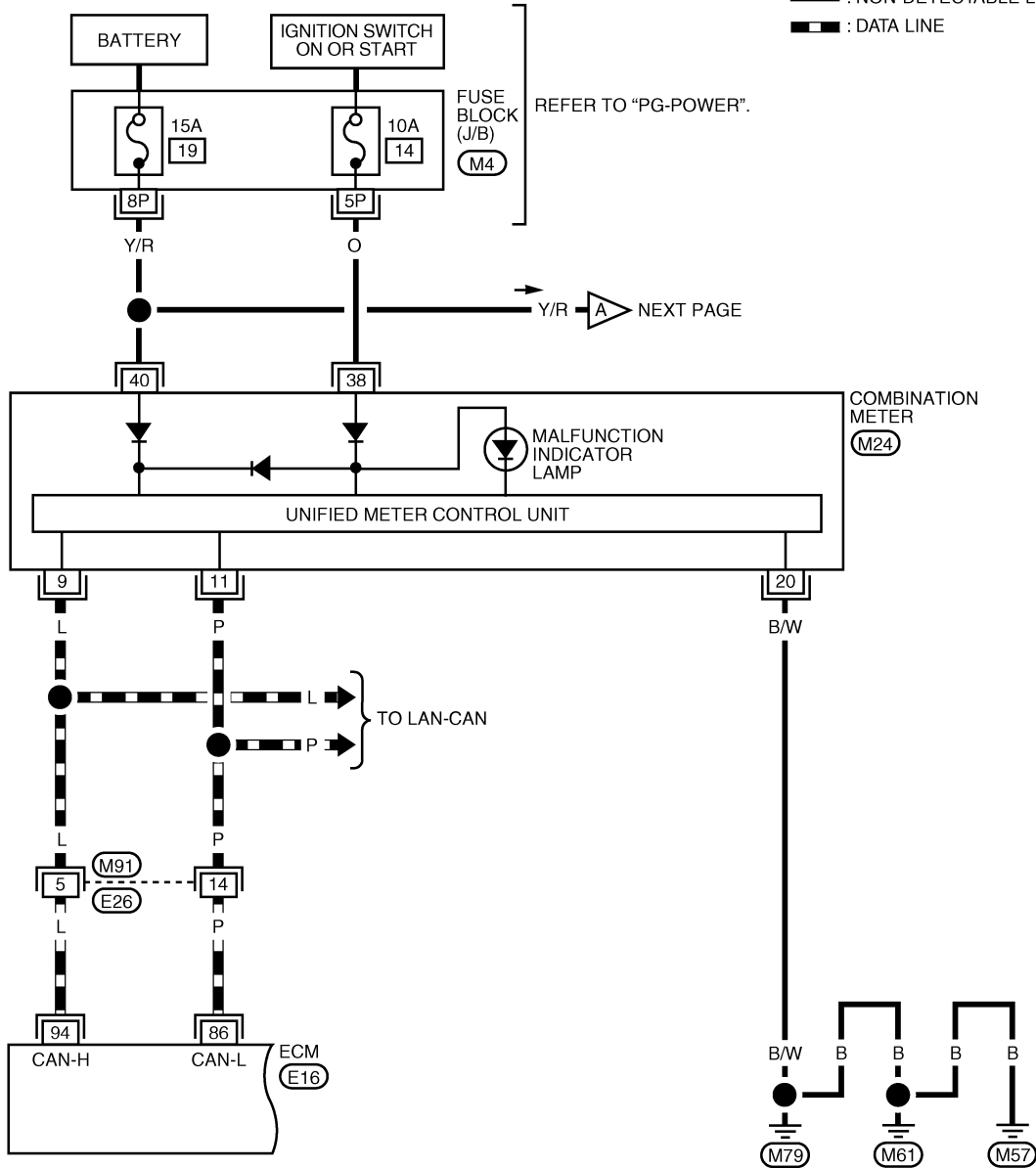

BBWA2544E

MIL AND DATA LINK CONNECTOR

EC-MIL/DL-02

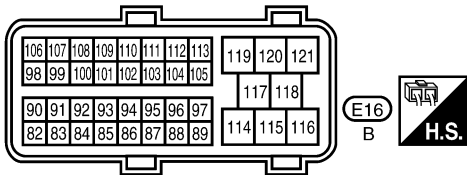
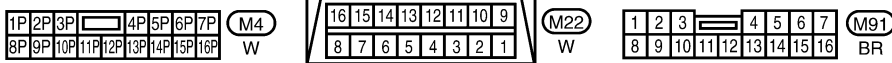
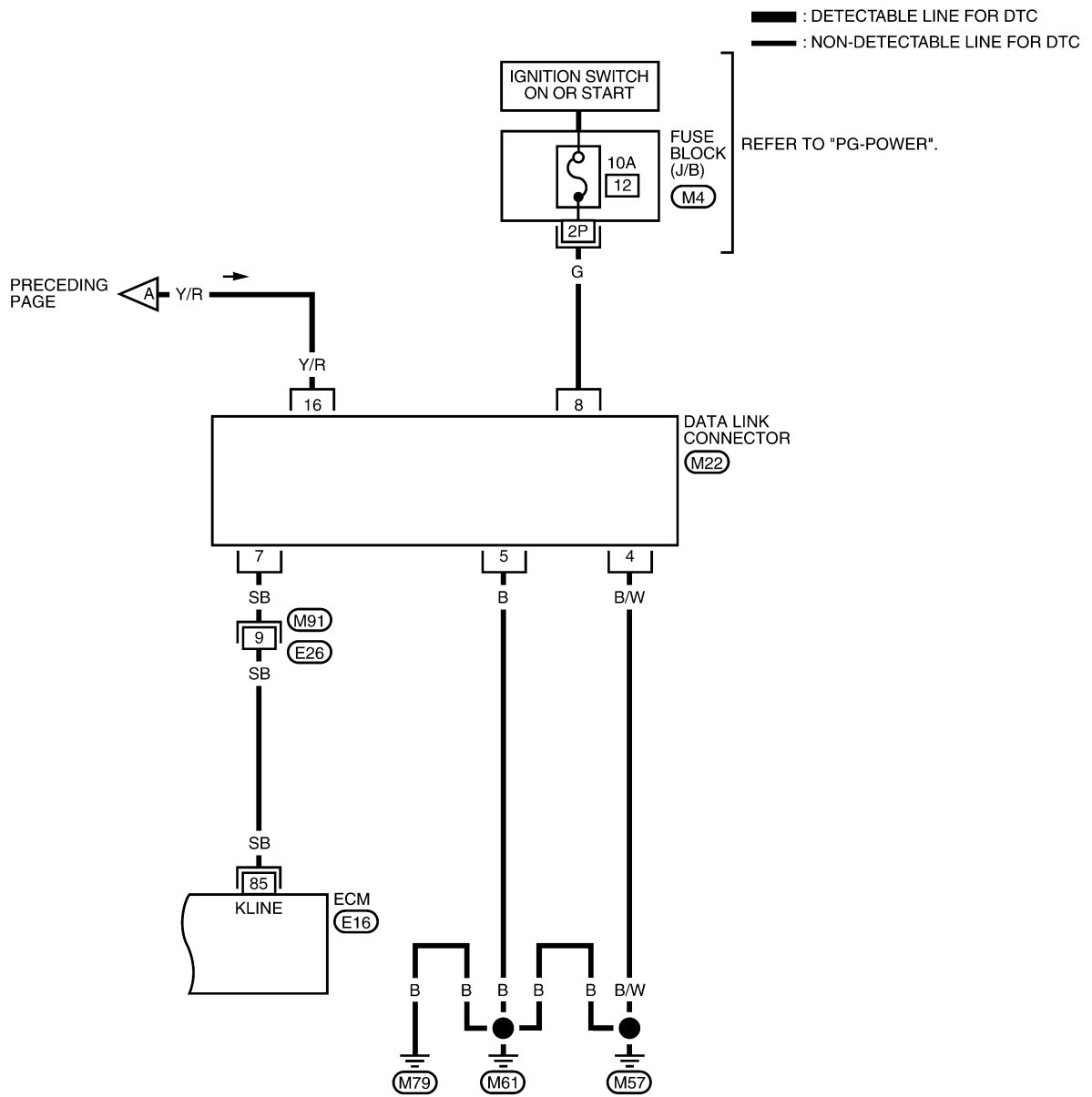

BBWA1653E

SERVICE DATA AND SPECIFICATIONS (SDS)

SERVICE DATA AND SPECIFICATIONS (SDS)

PF0:00030

Fuel Pressure

UBS00PGR

Fuel pressure at idling kPa (kg/cm ² , psi)	Approximately 350 (3.57, 51)
--	------------------------------

Idle Speed and Ignition Timing

UBS00PGS

Target idle speed	No load* (in P or N position)	675 ± 50 rpm
Air conditioner: ON	In P or N position	825 rpm or more
Ignition timing	In P or N position	15 ± 5° BTDC

*: Under the following conditions:

- Air conditioner switch: OFF
- Electric load: OFF (Lights, heater fan & rear window defogger)
- Steering wheel: Kept in straight-ahead position

Calculated Load Value

UBS00PGT

Conditions	Calculated load value % (Using CONSULT-II or GST)
At idle	5 - 35
At 2,500 rpm	5 - 35

Mass Air Flow Sensor

UBS00PGU

Supply voltage	Battery voltage (11 - 14V)
Output voltage at idle	1.0 - 1.3*V
Mass air flow (Using CONSULT-II or GST)	2.0 - 6.0 g·m/sec at idle* 7.0 - 20.0 g·m/sec at 2,500 rpm*

*: Engine is warmed up to normal operating temperature and running under no load.

Intake Air Temperature Sensor

UBS00PGV

Temperature °C (°F)	Resistance kΩ
25 (77)	1.800 - 2.200
80 (176)	0.283 - 0.359

Engine Coolant Temperature Sensor

UBS00PGW

Temperature °C (°F)	Resistance kΩ
20 (68)	2.1 - 2.9
50 (122)	0.68 - 1.00
90 (194)	0.236 - 0.260

EGR Temperature Sensor

UBS00PGX

Temperature °C (°F)	Resistance kΩ
0 (32)	0.73 - 0.88
50 (122)	0.074 - 0.082
100 (212)	0.011 - 0.014

Air Fuel Ratio (A/F) Sensor 1 Heater

UBS00PGY

Resistance [at 25°C (77°F)]	2.3 - 4.3Ω
-----------------------------	------------

Heated Oxygen sensor 2 Heater

UBS00PGZ

Resistance [at 25°C (77°F)]	5.0 - 7.0Ω
-----------------------------	------------

SERVICE DATA AND SPECIFICATIONS (SDS)

Crankshaft Position Sensor (POS)

UBS00PH0

Refer to [EC-386, "Component Inspection"](#) .

Camshaft Position Sensor (PHASE)

UBS00PH1

Refer to [EC-396, "Component Inspection"](#) .

Throttle Control Motor

UBS00PH2

Resistance [at 25°C (77°F)]	Approximately 1 - 15Ω
-----------------------------	-----------------------

Fuel Injector

UBS00PH3

Resistance [at 10 - 60°C (50 - 140°F)]	11.1 - 14.5Ω
--	--------------

Fuel Pump

UBS00PH4

Resistance [at 25°C (77°F)]	Approximately 0.2 - 5.0Ω
-----------------------------	--------------------------
