

SECTION **PB**  
PARKING BRAKE SYSTEM

A  
B  
C  
D  
E  
PB  
G  
H  
I  
J  
K  
L  
M  
N  
O  
P

CONTENTS

<b>SERVICE INFORMATION</b> .....	2	<b>PARKING BRAKE CONTROL</b> .....	5
<b>PRECAUTIONS</b> .....	2	Component .....	5
Precaution for Supplemental Restraint System (SRS) "AIR BAG" and "SEAT BELT PRE-TEN- SIONER" .....	2	Removal and Installation .....	5
<b>PREPARATION</b> .....	3	<b>PARKING BRAKE SHOE</b> .....	7
Commercial Service Tool .....	3	Component .....	7
<b>PARKING BRAKE SYSTEM</b> .....	4	Removal and Installation .....	7
On-Vehicle Service .....	4	<b>SERVICE DATA AND SPECIFICATIONS (SDS)</b> .....	10
		Parking Drum Brake .....	10
		Parking Brake Control .....	10

# PRECAUTIONS

< SERVICE INFORMATION >

---

## SERVICE INFORMATION

### PRECAUTIONS

#### Precaution for Supplemental Restraint System (SRS) "AIR BAG" and "SEAT BELT PRE-TENSIONER"

INFOID:000000001718280

The Supplemental Restraint System such as "AIR BAG" and "SEAT BELT PRE-TENSIONER", used along with a front seat belt, helps to reduce the risk or severity of injury to the driver and front passenger for certain types of collision. This system includes seat belt switch inputs and dual stage front air bag modules. The SRS system uses the seat belt switches to determine the front air bag deployment, and may only deploy one front air bag, depending on the severity of a collision and whether the front occupants are belted or unbelted. Information necessary to service the system safely is included in the SR and SB section of this Service Manual.

**WARNING:**

- To avoid rendering the SRS inoperative, which could increase the risk of personal injury or death in the event of a collision which would result in air bag inflation, all maintenance must be performed by an authorized NISSAN/INFINITI dealer.
- Improper maintenance, including incorrect removal and installation of the SRS, can lead to personal injury caused by unintentional activation of the system. For removal of Spiral Cable and Air Bag Module, see the SR section.
- Do not use electrical test equipment on any circuit related to the SRS unless instructed to in this Service Manual. SRS wiring harnesses can be identified by yellow and/or orange harnesses or harness connectors.

# PREPARATION

< SERVICE INFORMATION >

## PREPARATION

### Commercial Service Tool

INFOID:000000001718281

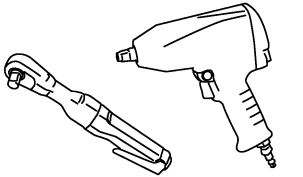
Tool name	Description
<p data-bbox="154 352 266 380">Power tool</p>  <p data-bbox="846 569 919 590">PBIC0190E</p>	<p data-bbox="998 352 1203 380">Removing fasteners</p>

A

B

C

D

E

**PB**

G

H

I

J

K

L

M

N

O

P

# PARKING BRAKE SYSTEM

< SERVICE INFORMATION >

## PARKING BRAKE SYSTEM

### On-Vehicle Service

INFOID:000000001718282

#### PEDAL STROKE

- When parking brake pedal is operated at specified force, make sure the stroke is within the specified number of notches. (Check it by listening and counting the ratchet clicks.)

**Pedal force : 196 N (20 kg-f, 44 lb-f)**

**Pedal stroke : 5 to 6 notches**

- If the pedal stroke is not within specification, perform the adjustment operation. Refer to "ADJUSTMENT".

#### INSPECT COMPONENTS

- Make sure the components are attached properly (check for looseness, backlash, etc.).
- Check parking brake pedal assembly for bend, damage and cracks, and replace if necessary.
- Check cable for wear and damage, and replace if necessary.
- Check parking brake warning lamp switch for malfunction, and replace if necessary. Refer to [DI-24. "Wiring Diagram - WARN -"](#).

#### ADJUSTMENT

- Remove lower instrument panel LH using power tool. Refer to [IP-12. "Instrument Lower Panel LH"](#).
- Insert a deep socket wrench to rotate adjusting nut and loosen the cable sufficiently. Then, return the pedal to the free height.
- Remove wheel and tire from the vehicle using power tool.
- Using wheel nuts, secure the disc to the hub and prevent it from tilting.

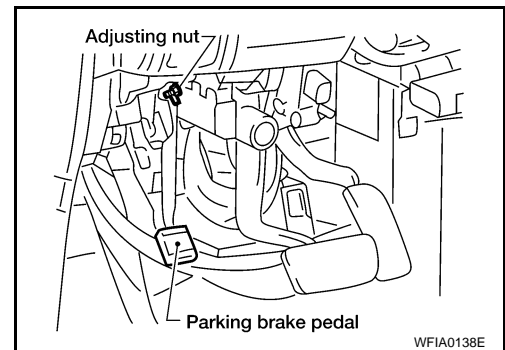

- Remove adjusting hole plug installed on the disc rotor. Rotate the adjuster in direction "A" as shown, until the disc rotor is locked, using a suitable tool. After locking, turn the adjuster in the opposite direction by 5 or 6 notches.
- Rotate the disc rotor to make sure there is no drag. Install the adjusting hole plug.
- Adjust cable as follows:
  - Operate pedal 10 or more times with a force of 294 N (30 kg-f, 66 lb-f).
  - Rotate adjusting nut with deep socket to adjust pedal stroke.

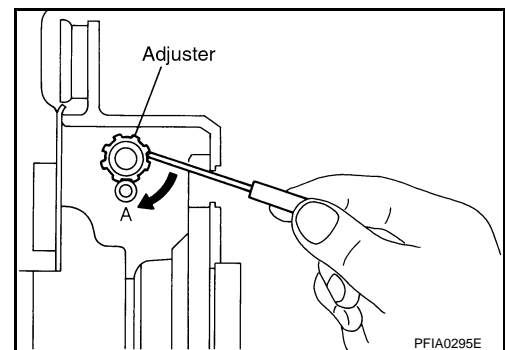

#### NOTE:

Do not reuse the adjusting nut after removing it.

- When parking brake pedal is operated at specified force, make sure the stroke is within the specified number of notches. (Check it by listening and counting the ratchet clicks.)

**Pedal force : 196 N (20 kg-f, 44 lb-f)**

**Pedal stroke : 5 to 6 notches**

- With the pedal completely returned, make sure there is no drag on the rear brake.

# PARKING BRAKE CONTROL

< SERVICE INFORMATION >

## PARKING BRAKE CONTROL

### Component

INFOID:000000001718283

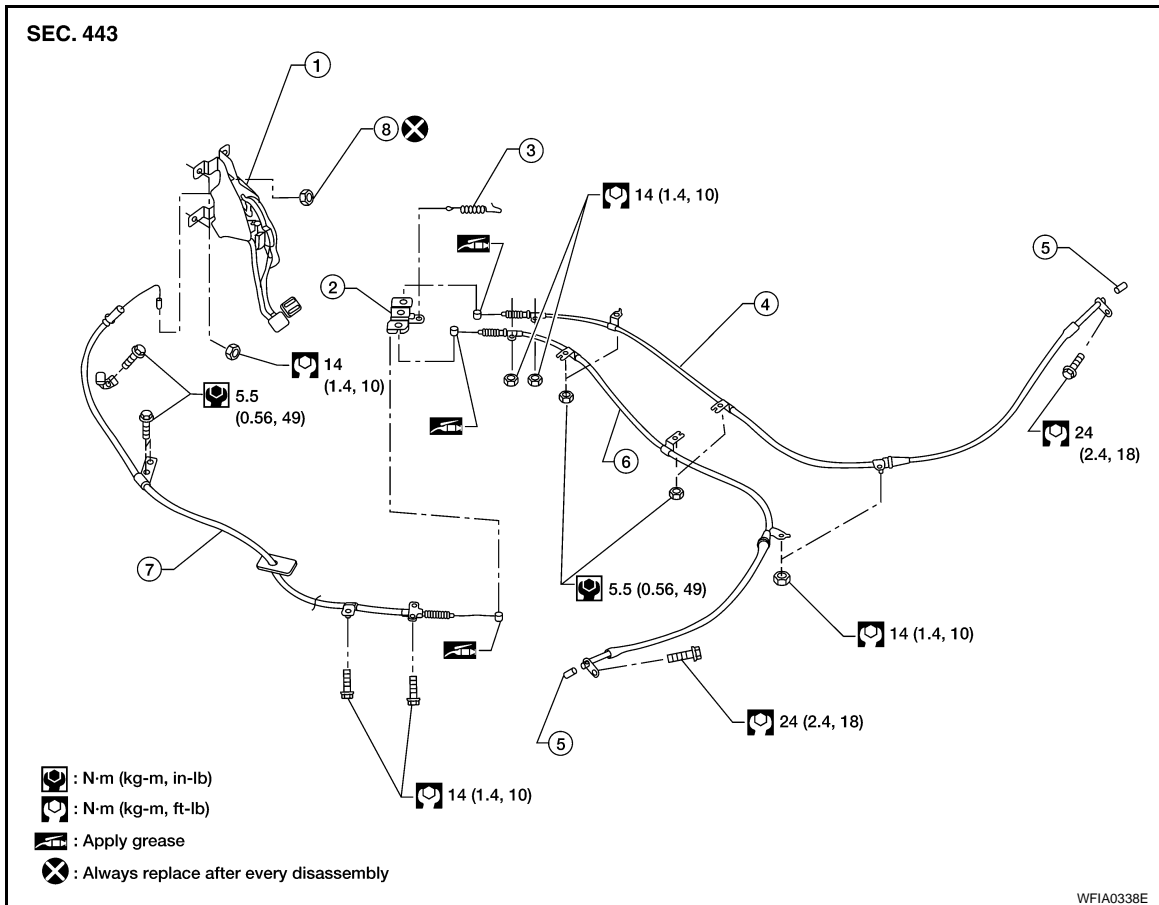

- |                                 |                  |                    |
|---------------------------------|------------------|--------------------|
| 1. Parking brake pedal assembly | 2. Equalizer     | 3. Return spring   |
| 4. Rear right cable             | 5. Pin           | 6. Rear left cable |
| 7. Front cable                  | 8. Adjusting nut |                    |

### Removal and Installation

INFOID:000000001718284

#### REMOVAL

1. Remove instrument lower panel LH and knee protector using power tool. Refer to [IP-12, "Instrument Lower Panel LH"](#).
2. Disconnect parking brake switch electrical connector.
3. Remove adjusting nut from threaded end of front cable.
4. Remove parking brake pedal assembly nuts.
5. Disconnect front cable from parking brake pedal assembly while compressing legs of spring clip.
6. Remove parking brake pedal assembly.
7. Remove center console. Refer to [IP-10, "Instrument Panel"](#).
8. Remove front cable bolts, then remove front cable from vehicle.
9. Remove rear disc rotors. Refer to [BR-33, "Removal and Installation of Caliper Assembly and Disc Rotor"](#).

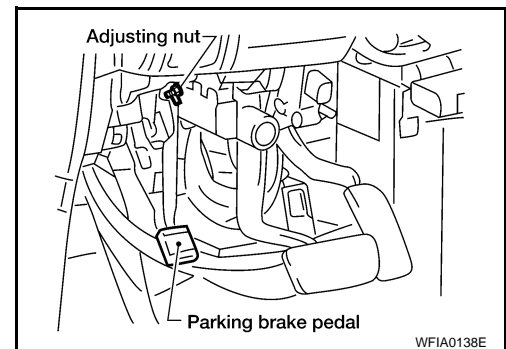

## PARKING BRAKE CONTROL

### < SERVICE INFORMATION >

10. Remove rear cables from toggle levers.
11. Remove right and left rear cables nuts and bolts, then remove right and left cable assemblies from vehicle.

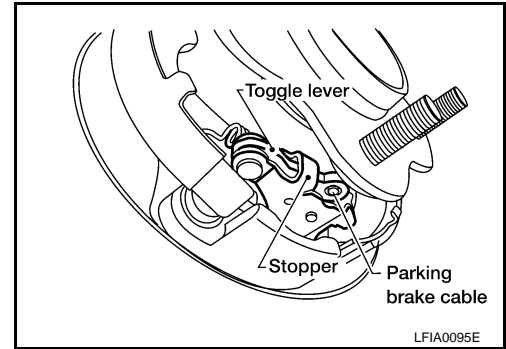

### INSTALLATION

Installation is in the reverse order of removal.

- Tighten the nuts and bolts to specification.
- Adjust the parking brake. Refer to [PB-4, "On-Vehicle Service"](#).

#### **NOTE:**

Do not reuse the adjusting nut.

# PARKING BRAKE SHOE

< SERVICE INFORMATION >

## PARKING BRAKE SHOE

Component

INFOID:000000001718285

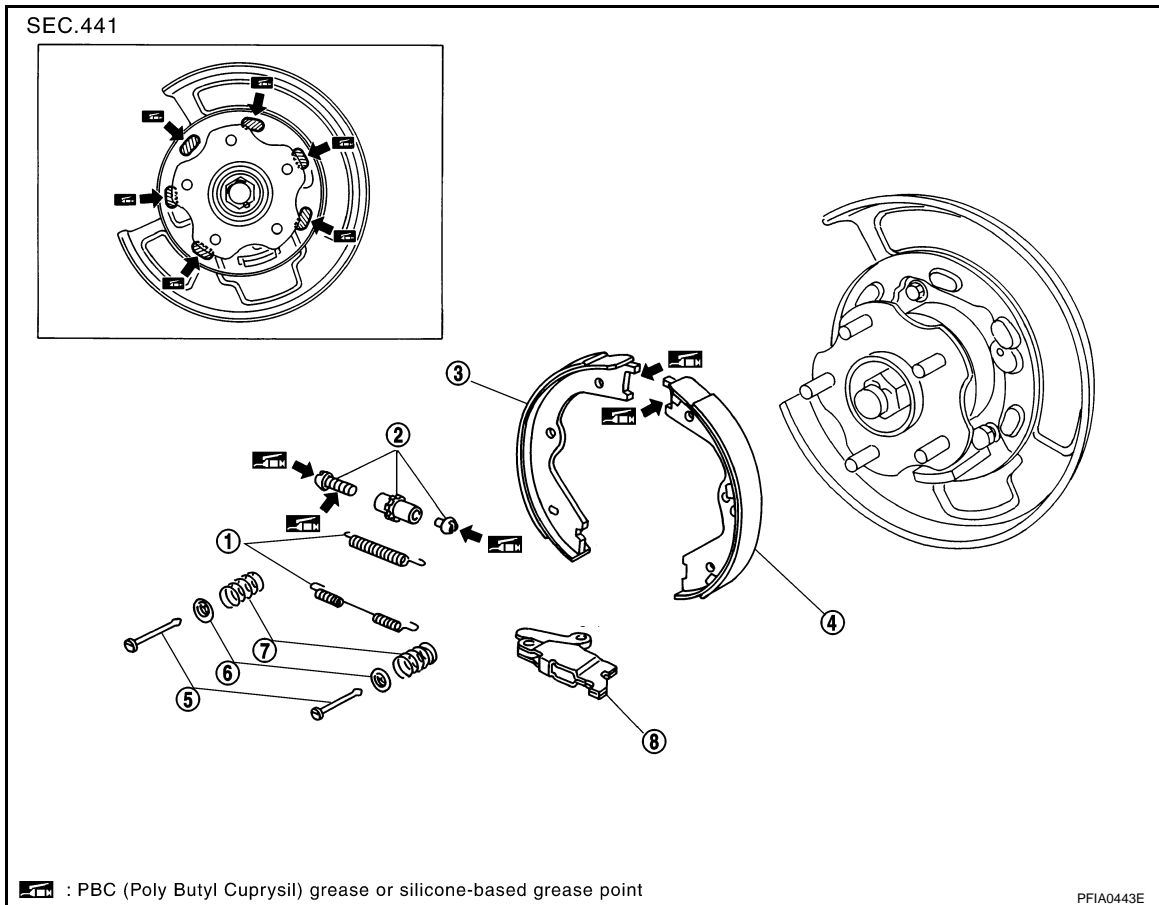

## Removal and Installation

INFOID:000000001718286

### REMOVAL

#### CAUTION:

**Clean dust on the disc and back plate with a vacuum dust collector. Do not blow with compressed air.**

1. Remove wheel and tire using power tool.
2. Remove the disc rotor with the parking brake pedal completely in the released position.
3. If disc rotor cannot be removed, remove as follows:
  - a. Secure the disc rotor in place with wheel nuts and remove disc rotor plug.

# PARKING BRAKE SHOE

## < SERVICE INFORMATION >

- b. Rotate adjuster in direction "B" to retract and loosen brake shoes, using a suitable tool.
4. Remove the anti-rattle pins, retainers, and anti-rattle springs, then return springs.
5. Remove the parking brake shoes, adjuster assembly, and toggle lever.

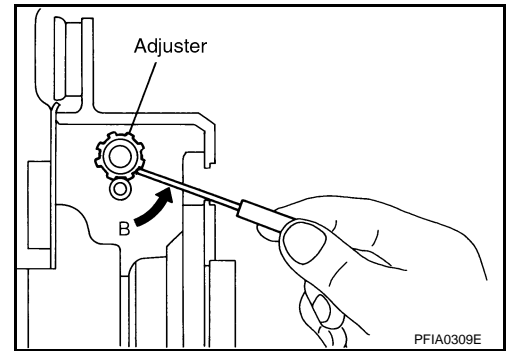

## INSPECTION AFTER REMOVAL

### Lining Thickness Inspection

- Check thickness of lining.

**Standard thickness (new) "A" : 3.2 mm (0.126 in)**

**Repair limit thickness "A" : 1.5 mm (0.059 in)**

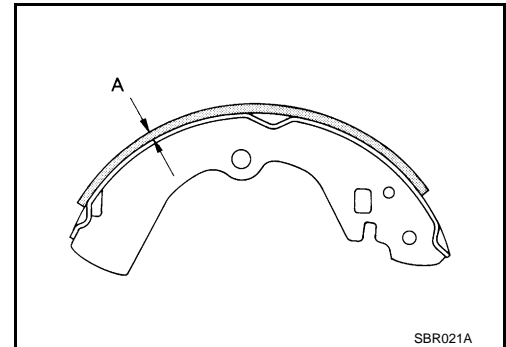

### Drum Inner Diameter Inspection

- Check drum inner diameter.

**Standard inner diameter (new) : 190 mm (7.48 in)**

**Wear limit of inner diameter : 191 mm (7.52 in)**

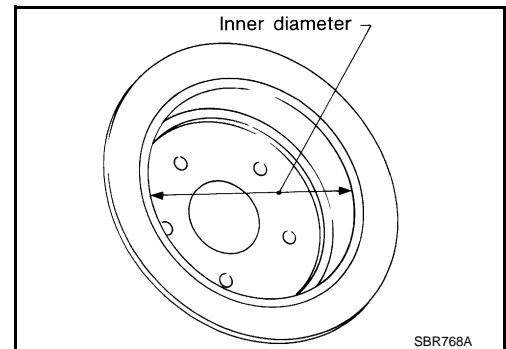

### Other Inspections

- Check shoe sliding surface for excessive wear and damage.
- Check anti-rattle pin for excessive wear and corrosion.
- Check return spring for sagging.
- Check that adjuster moves smoothly.
- Check either visually or with a vernier caliper to see if there is any excessive wear, cracks, or damage inside the drum.

## INSTALLATION

Installation is in the reverse order of removal, observing the following:

- Refer to [PB-7, "Component"](#) and apply brake grease to the specified points during assembly.
- There is a difference between the adjusters orientation from left and right. Assemble the adjuster so the threaded part expands when rotating it in the direction shown by the arrow.
- Shorten adjuster by rotating it.
- When disassembling the adjuster, apply PBC (Poly Butyl Cuprysil) grease or silicone based grease to the threads. Refer to [MA-11](#).
- After replacing brake shoes or disc rotors, or if brakes do not function well, perform break-in operation as follows.

1. Adjust the parking brake pedal stroke to the specified stroke. Refer to [PB-4, "On-Vehicle Service"](#).
2. Perform break-in (drag run) operation by driving the vehicle under the following conditions:

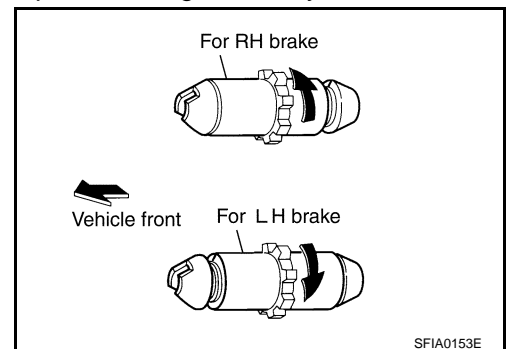

### Drive forward

- **Vehicle speed approx. 40 km/h (25 MPH) set (forward)**



# PARKING BRAKE SHOE

## < SERVICE INFORMATION >

---

- **Parking brake operating force approx. 147 N (15 kg-f, 33 lb-f) set**
- **Distance approx. 100 m (328 ft)**

3. After break-in operation, check lever stroke of the parking brake. Readjust if it is no longer at the specified stroke.
- To prevent the lining from getting too hot, allow a cool off period of approximately 5 minutes after every break-in operation.
  - Do not perform excessive break-in operations, because it may cause uneven or early wear of the lining.

A  
B  
C  
D  
E  
G  
H  
I  
J  
K  
L  
M  
N  
O  
P

**PB**

## SERVICE DATA AND SPECIFICATIONS (SDS)

< SERVICE INFORMATION >

### SERVICE DATA AND SPECIFICATIONS (SDS)

#### Parking Drum Brake

INFOID:000000001718287

Type		DS19HC
Brake lining	Standard thickness (new)	3.2 mm (0.126 in)
	Wear limit thickness	1.5 mm (0.059 in)
Drum (disc)	Standard inner diameter (new)	190 mm (7.48 in)
	Wear limit of inner diameter	191 mm (7.52 in)

#### Parking Brake Control

INFOID:000000001718288

Control type	Foot pedal
Number of notches [under force of 196 N (20 kg-f, 44 lb-f)]	5 to 6 notches
Number of notches when warning lamp switch activates warning lamp	1 notch