

A
CO
C
D
E
F
G
H
I
J
K
L
M
N
O
P

SECTION CO

ENGINE COOLING SYSTEM

CONTENTS

FUNCTION DIAGNOSIS	2	RADIATOR	13
DESCRIPTION	2	RADIATOR CAP	13
Engine Cooling System	2	RADIATOR CAP : Inspection	13
Engine Cooling System Schematic	3	RADIATOR	13
SYMPTOM DIAGNOSIS	4	RADIATOR : Inspection	13
OVERHEATING CAUSE ANALYSIS	4	ON-VEHICLE REPAIR	15
Troubleshooting Chart	4	RADIATOR	15
PRECAUTION	6	Exploded View	15
PRECAUTIONS	6	Removal and Installation	16
FOR USA AND CANADA	6	Disassembly and Assembly	17
FOR USA AND CANADA : Precaution Necessary		Inspection	20
for Steering Wheel Rotation After Battery Discon-		COOLING FAN	21
nect	6	Exploded View	21
FOR USA AND CANADA : Precaution for Supple-		Removal and Installation	21
mental Restraint System (SRS) "AIR BAG" and		Disassembly and Assembly	22
"SEAT BELT PRE-TENSIONER"	6	Inspection	22
FOR MEXICO	6	WATER PUMP	23
FOR MEXICO : Precaution Necessary for Steer-		Exploded View	23
ing Wheel Rotation After Battery Disconnect	6	Removal and Installation	23
FOR MEXICO : Precaution for Supplemental Re-		Inspection	24
straint System (SRS) "AIR BAG" and "SEAT BELT		THERMOSTAT AND WATER CONTROL	
PRE-TENSIONER"	7	VALVE	25
PREPARATION	8	Exploded View	25
PREPARATION	8	Removal and Installation	25
Special Service Tools	8	Inspection	26
Commercial Service Tools	8	SERVICE DATA AND SPECIFICATIONS	
ON-VEHICLE MAINTENANCE	9	(SDS)	28
ENGINE COOLANT	9	SERVICE DATA AND SPECIFICATIONS	
Inspection	9	(SDS)	28
Draining	9	Periodical Maintenance Specification	28
Refilling	10	Radiator	28
Flushing	11	Thermostat	28
		Water control valve	28

DESCRIPTION

< FUNCTION DIAGNOSIS >

FUNCTION DIAGNOSIS

DESCRIPTION

Engine Cooling System

INFOID:000000001713791

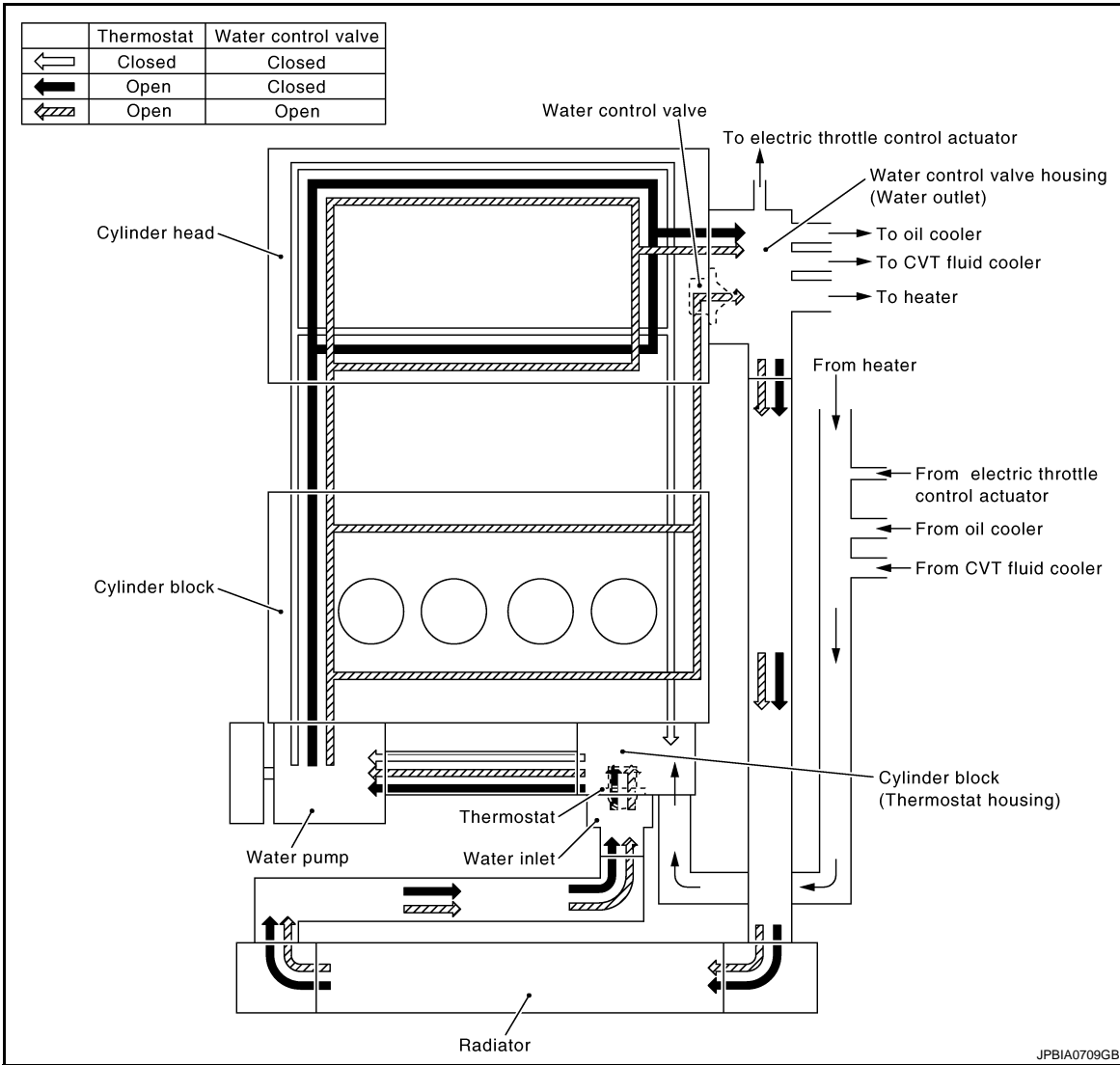

DESCRIPTION

< FUNCTION DIAGNOSIS >

Engine Cooling System Schematic

INFOID:000000001713792

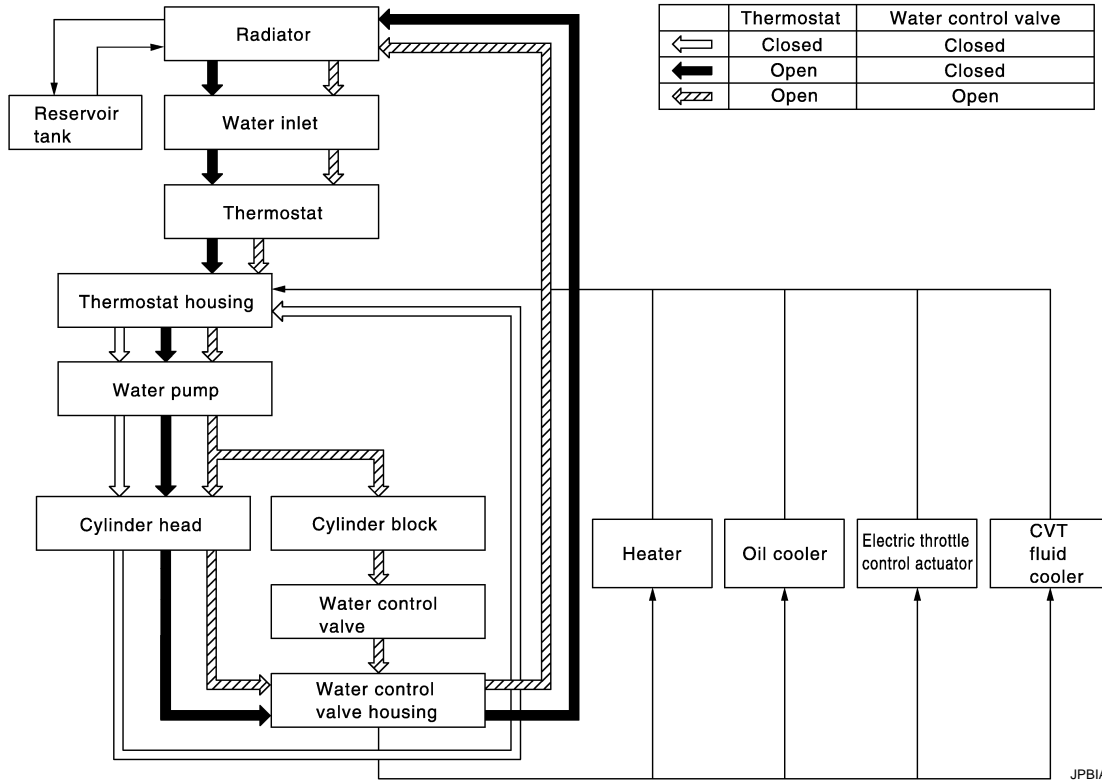

JPBIA0710GB

A
CO
C
D
E
F
G
H
I
J
K
L
M
N
O
P

OVERHEATING CAUSE ANALYSIS

< SYMPTOM DIAGNOSIS >

SYMPTOM DIAGNOSIS

OVERHEATING CAUSE ANALYSIS

Troubleshooting Chart

INFOID:000000001713793

		Symptom	Check items	
Cooling system parts malfunction	Poor heat transfer	Water pump malfunction	Worn or loose drive belt	—
		Thermostat and water control valve stuck closed	—	
		Damaged radiator fins	Dust contamination or paper clogging	
			Physical damage	
		Clogged radiator cooling tube	Excess foreign material (rust, dirt, sand, etc.)	
	Reduced air flow	Cooling fan does not operate	Fan assembly	—
		High resistance to fan rotation		
		Damaged fan blades		
		Damaged radiator shroud	—	—
		Improper engine coolant mixture ratio	—	—
		Poor engine coolant quality	—	Engine coolant density
	Insufficient engine coolant	Engine coolant leakage	Cooling hose	Loose clamp
				Cracked hose
			Water pump	Poor sealing
			Radiator cap	Loose
Poor sealing				
Radiator		O-ring for damage, deterioration or improper fitting		
		Cracked radiator tank		
		Cracked radiator core		
	Reservoir tank	Cracked reservoir tank		
Overflowing reservoir tank	Exhaust gas leaks into cooling system	Cylinder head deterioration		
		Cylinder head gasket deterioration		

OVERHEATING CAUSE ANALYSIS

< SYMPTOM DIAGNOSIS >

	Symptom		Check items		
Except cooling system parts malfunction	—	Overload on engine	Abusive driving	High engine rpm under no load	A
				Driving in low gear for extended time	CO
				Driving at extremely high speed	
				Powertrain system malfunction	C
				Installed improper size wheels and tires	D
				Dragging brakes	
			Improper ignition timing	E	
	Blocked or restricted air flow	Blocked bumper	—		E
		Blocked radiator grille	Installed car brassiere		F
			Mud contamination or paper clogging	—	
		Blocked radiator	—		G
		Blocked condenser	Blocked air flow		G
Installed large fog lamp					

A
CO
C
D
E
F
G
H
I
J
K
L
M
N
O
P

PRECAUTIONS

< PRECAUTION >

PRECAUTION

PRECAUTIONS FOR USA AND CANADA

FOR USA AND CANADA : Precaution Necessary for Steering Wheel Rotation After Battery Disconnect

INFOID:000000003248374

NOTE:

- This Procedure is applied only to models with Intelligent Key system and NVIS/IVIS (NISSAN/INFINITI VEHICLE IMMOBILIZER SYSTEM - NATS).
- Remove and install all control units after disconnecting both battery cables with the ignition knob in the "LOCK" position.
- Always use CONSULT-III to perform self-diagnosis as a part of each function inspection after finishing work. If DTC is detected, perform trouble diagnosis according to self-diagnostic results.

For models equipped with the Intelligent Key system and NVIS/IVIS, an electrically controlled steering lock mechanism is adopted on the key cylinder.

For this reason, if the battery is disconnected or if the battery is discharged, the steering wheel will lock and steering wheel rotation will become impossible.

If steering wheel rotation is required when battery power is interrupted, follow the procedure below before starting the repair operation.

OPERATION PROCEDURE

1. Connect both battery cables.

NOTE:

Supply power using jumper cables if battery is discharged.

2. Use the Intelligent Key or mechanical key to turn the ignition switch to the "ACC" position. At this time, the steering lock will be released.
3. Disconnect both battery cables. The steering lock will remain released and the steering wheel can be rotated.
4. Perform the necessary repair operation.
5. When the repair work is completed, return the ignition switch to the "LOCK" position before connecting the battery cables. (At this time, the steering lock mechanism will engage.)
6. Perform a self-diagnosis check of all control units using CONSULT-III.

FOR USA AND CANADA : Precaution for Supplemental Restraint System (SRS) "AIR BAG" and "SEAT BELT PRE-TENSIONER"

INFOID:000000003248373

The Supplemental Restraint System such as "AIR BAG" and "SEAT BELT PRE-TENSIONER", used along with a front seat belt, helps to reduce the risk or severity of injury to the driver and front passenger for certain types of collision. This system includes seat belt switch inputs and dual stage front air bag modules. The SRS system uses the seat belt switches to determine the front air bag deployment, and may only deploy one front air bag, depending on the severity of a collision and whether the front occupants are belted or unbelted.

Information necessary to service the system safely is included in the "SRS AIRBAG" and "SEAT BELT" of this Service Manual.

WARNING:

- **To avoid rendering the SRS inoperative, which could increase the risk of personal injury or death in the event of a collision which would result in air bag inflation, all maintenance must be performed by an authorized NISSAN/INFINITI dealer.**
- **Improper maintenance, including incorrect removal and installation of the SRS, can lead to personal injury caused by unintentional activation of the system. For removal of Spiral Cable and Air Bag Module, see the "SRS AIRBAG".**
- **Do not use electrical test equipment on any circuit related to the SRS unless instructed to in this Service Manual. SRS wiring harnesses can be identified by yellow and/or orange harnesses or harness connectors.**

FOR MEXICO

FOR MEXICO : Precaution Necessary for Steering Wheel Rotation After Battery Dis-

PRECAUTIONS

< PRECAUTION >

connect

INFOID:000000003248371

NOTE:

- This Procedure is applied only to models with Intelligent Key system and NVIS/IVIS (NISSAN/INFINITI VEHICLE IMMOBILIZER SYSTEM - NATS).
- Remove and install all control units after disconnecting both battery cables with the ignition knob in the "LOCK" position.
- Always use CONSULT-III to perform self-diagnosis as a part of each function inspection after finishing work. If DTC is detected, perform trouble diagnosis according to self-diagnostic results.

For models equipped with the Intelligent Key system and NVIS/IVIS, an electrically controlled steering lock mechanism is adopted on the key cylinder.

For this reason, if the battery is disconnected or if the battery is discharged, the steering wheel will lock and steering wheel rotation will become impossible.

If steering wheel rotation is required when battery power is interrupted, follow the procedure below before starting the repair operation.

OPERATION PROCEDURE

1. Connect both battery cables.

NOTE:

Supply power using jumper cables if battery is discharged.

2. Use the Intelligent Key or mechanical key to turn the ignition switch to the "ACC" position. At this time, the steering lock will be released.
3. Disconnect both battery cables. The steering lock will remain released and the steering wheel can be rotated.
4. Perform the necessary repair operation.
5. When the repair work is completed, return the ignition switch to the "LOCK" position before connecting the battery cables. (At this time, the steering lock mechanism will engage.)
6. Perform a self-diagnosis check of all control units using CONSULT-III.

FOR MEXICO : Precaution for Supplemental Restraint System (SRS) "AIR BAG" and "SEAT BELT PRE-TENSIONER"

INFOID:000000003248372

The Supplemental Restraint System such as "AIR BAG" and "SEAT BELT PRE-TENSIONER", used along with a front seat belt, helps to reduce the risk or severity of injury to the driver and front passenger for certain types of collision. Information necessary to service the system safely is included in the "SRS AIRBAG" and "SEAT BELT" of this Service Manual.

WARNING:

- To avoid rendering the SRS inoperative, which could increase the risk of personal injury or death in the event of a collision which would result in air bag inflation, all maintenance must be performed by an authorized NISSAN/INFINITI dealer.
- Improper maintenance, including incorrect removal and installation of the SRS, can lead to personal injury caused by unintentional activation of the system. For removal of Spiral Cable and Air Bag Module, see the "SRS AIRBAG".
- Do not use electrical test equipment on any circuit related to the SRS unless instructed to in this Service Manual. SRS wiring harnesses can be identified by yellow and/or orange harnesses or harness connectors.

PREPARATION

< PREPARATION >

PREPARATION

PREPARATION

Special Service Tools

INFOID:000000001713796

Tool number (Kent-Moore No.) Tool name	Description
KV99103510 (—) Radiator plate pliers A	Installing radiator upper and lower tanks
KV99103520 (—) Radiator plate pliers B	Removing radiator upper and lower tanks

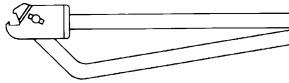

S-NT224



S-NT225

Commercial Service Tools

INFOID:000000001713797

Tool name	Description
Radiator cap tester	Checking radiator and radiator cap
Radiator cap tester adapter	Adapting radiator cap tester to radiator cap and radiator filler neck a: 28 (1.10) dia. b: 31.4 (1.236) dia. c: 41.3 (1.626) dia. Unit: mm (in)

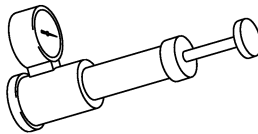

PBIC1982E

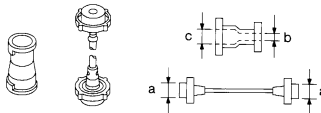

S-NT564

ENGINE COOLANT

< ON-VEHICLE MAINTENANCE >

ON-VEHICLE MAINTENANCE

ENGINE COOLANT

Inspection

INFOID:000000001713798

LEVEL

- Check that the reservoir tank engine coolant level is within the "MIN" to "MAX" when the engine is cool.

A : MAX

B : MIN

- Adjust the engine coolant level if necessary.

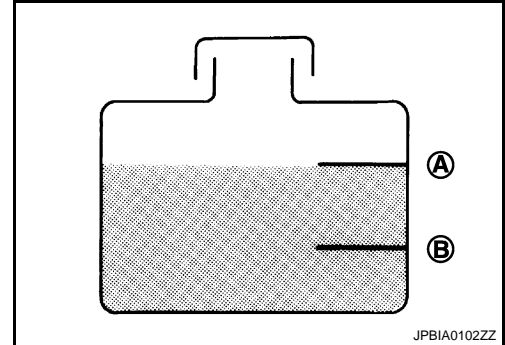

LEAKAGE

- To check for leaks, apply pressure to the cooling system with the radiator cap tester (commercial service tool) (A) and the radiator cap tester adapter (commercial service tool) (B).

Testing pressure: Refer to [CO-28, "Radiator"](#).

WARNING:

Never remove radiator cap when engine is hot. Serious burns may occur from high-pressure engine coolant escaping from radiator.

CAUTION:

Higher test pressure than specified may cause radiator damage.

NOTE:

In a case that engine coolant decreases, replenish radiator with engine coolant.

- If anything is found, repair or replace damaged parts.

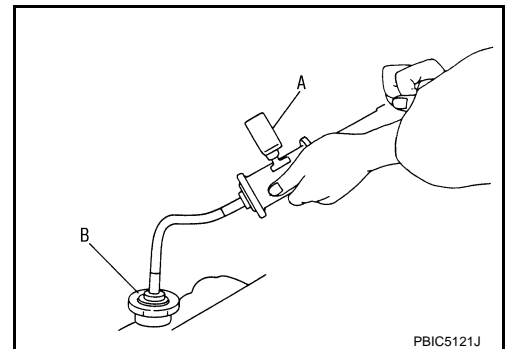

Draining

INFOID:000000001713799

WARNING:

- Never remove radiator cap when engine is hot. Serious burns may occur from high-pressure engine coolant escaping from radiator.
- Wrap a thick cloth around the radiator cap. Slowly turn it a quarter of a turn to release built-up pressure. Then turn it all the way.

1. Remove engine under cover.
2. Open radiator drain plug at the bottom of radiator, and then remove radiator cap.

A : Radiator drain plug hole

↙ : Vehicle front

CAUTION:

Perform this step when engine is cold.

- When draining all of engine coolant in the system, open water drain plugs on cylinder block. Refer to [EM-86, "Exploded View"](#).

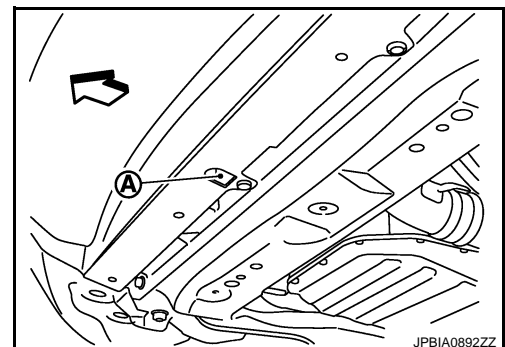

3. Remove reservoir tank if necessary, and drain engine coolant and clean reservoir tank before installing.

ENGINE COOLANT

< ON-VEHICLE MAINTENANCE >

- Move reservoir tank (3), and then remove it numerical order as shown in the figure.

↔ : Vehicle front

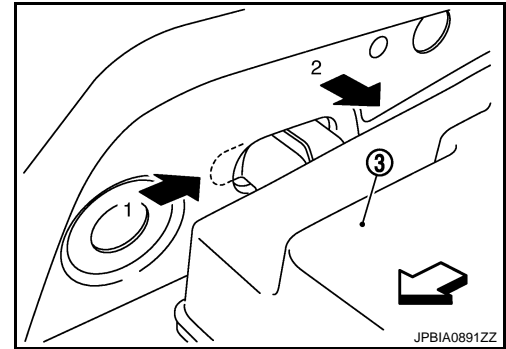

4. Check drained engine coolant for contaminants such as rust, corrosion or discoloration. If contaminated, flush the engine cooling system. Refer to [CO-11, "Flushing"](#).

Refilling

INFOID:000000001713800

1. Install reservoir tank if removed, and radiator drain plug.

CAUTION:

Be sure to clean drain plug and install with new O-ring.

Radiator drain plug: Refer to [CO-15, "Exploded View"](#).

- If water drain plugs on cylinder block are removed, close and tighten them. Refer to [EM-86, "Exploded View"](#).
2. Check that each hose clamp has been firmly tightened.
 3. Remove air duct assembly, and move electric throttle control actuator to aside. Refer to [EM-27, "Exploded View"](#) and [EM-29, "Exploded View"](#).
 4. Disconnect heater hose (1) at the position (↔) in the figure.

↔ : Vehicle front

- Lift up the heater hose end approximately 100 mm (3.94 in) (a) higher than the height at installation.

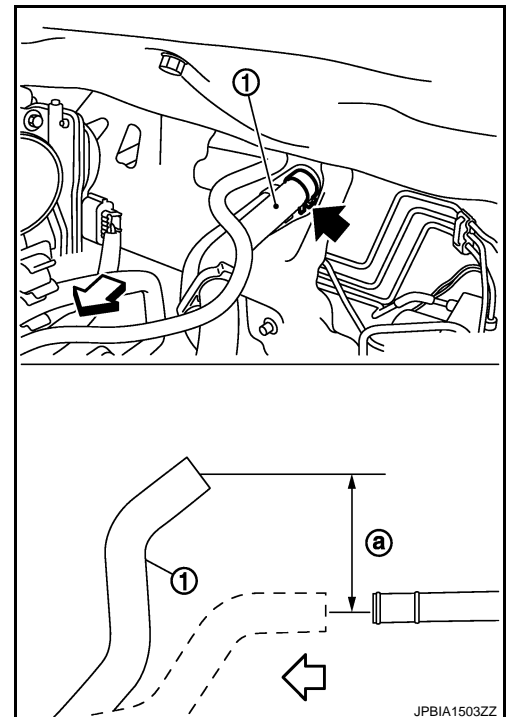

ENGINE COOLANT

< ON-VEHICLE MAINTENANCE >

5. Fill radiator (1) to specified level.

CAUTION:

Never adhere the engine coolant to electronic equipments (alternator etc.).

- Pour engine coolant through engine coolant filler neck slowly of less than 2 ℓ (2-1/8 US qt, 1-3/4 Imp qt) a minute to allow air in system to escape.
- When engine coolant overflows disconnected heater hose, connect heater hose, and continue filling the engine coolant.
- Use Genuine NISSAN Long Life Antifreeze/Coolant or equivalent mixed with water (distilled or demineralized). Refer to [MA-17, "FOR NORTH AMERICA : Fluids and Lubricants"](#) (Except for Mexico) or [MA-18, "FOR MEXICO : Fluids and Lubricants"](#) (for Mexico).

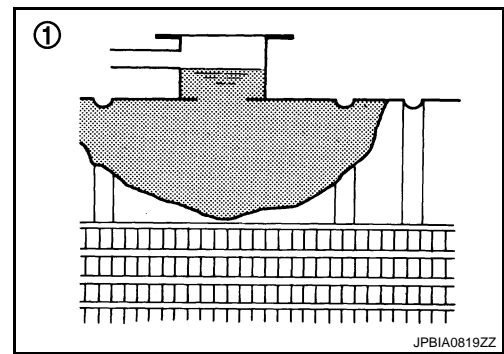

Engine coolant capacity

(With reservoir tank at "MAX" level)

Refer to [CO-28, "Periodical Maintenance Specification"](#).

6. Refill reservoir tank to "MAX" level line with engine coolant.

A : MAX

B : MIN

Reservoir tank engine coolant capacity

(At "MAX" level)

Refer to [CO-28, "Periodical Maintenance Specification"](#).

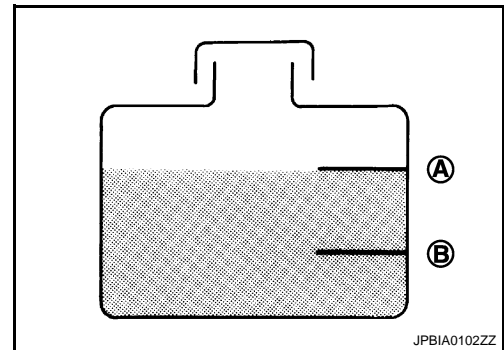

7. Install radiator cap.
8. Install air duct assembly and electric throttle control actuator. Refer to [EM-27, "Exploded View"](#) and [EM-29, "Exploded View"](#).
9. Warm up engine until opening thermostat. Standard for warming-up time is approximately 10 minutes at 3,000 rpm.
- Check thermostat opening condition by touching radiator hose (lower) to see a flow of warm water.
- CAUTION:**
Watch water temperature gauge so as not to overheat engine.
10. Stop the engine and cool down to less than approximately 50°C (122°F).
- Cool down using fan to reduce the time.
 - If necessary, refill radiator up to filler neck with engine coolant.
- CAUTION:**
Never adhere the engine coolant to electronic equipments (alternator etc.).
11. Refill reservoir tank to "MAX" level line with engine coolant.
12. Repeat steps 5 through 10 two or more times with radiator cap installed until engine coolant level no longer drops.
13. Check cooling system for leakage with engine running.
14. Warm up the engine, and check for sound of engine coolant flow while running engine from idle up to 3,000 rpm with heater temperature controller set at several position between "COOL" and "WARM".
- Sound may be noticeable at heater unit.
15. Repeat step 14 three times.
16. If sound is heard, bleed air from cooling system by repeating step 5 through 10 until engine coolant level no longer drops.

Flushing

INFOID:000000001713801

1. Install reservoir tank if removed, and radiator drain plug.

CAUTION:

Be sure to clean drain plug and install with new O-ring.

ENGINE COOLANT

< ON-VEHICLE MAINTENANCE >

Radiator drain plug : Refer to [CO-15, "Exploded View"](#).

- If water drain plugs on cylinder block are removed, close and tighten them. Refer to [EM-86, "Exploded View"](#).
2. Remove air duct assembly and move electric throttle control actuator to aside. Refer to [EM-27, "Exploded View"](#) and [EM-29, "Exploded View"](#).
3. Disconnect heater hose (1) at the position (◀) in the figure.

◀ : Vehicle front

- Lift up the heater hose end approximately 100 mm (3.94 in) (a) higher than the height at installation.

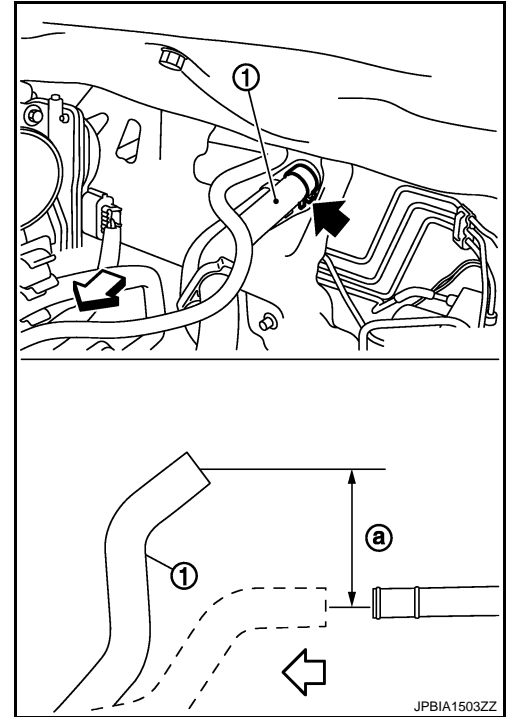

4. Fill radiator and reservoir tank with water and reinstall radiator cap.
 - When engine coolant overflows disconnected heater hose, connect heater hose, and continue filling the engine coolant.
5. Install air duct assembly and electric throttle control actuator. Refer to [EM-27, "Exploded View"](#) and [EM-29, "Exploded View"](#).
6. Run the engine and warm it up to normal operating temperature.
7. Rev the engine two or three times under no-load.
8. Stop the engine and wait until it cools down.
9. Drain water from the system. Refer to [CO-9, "Draining"](#).
10. Repeat steps 1 through 9 until clear water begins to drain from radiator.

RADIATOR

< ON-VEHICLE MAINTENANCE >

RADIATOR RADIATOR CAP

RADIATOR CAP : Inspection

INFOID:000000001713802

- Check valve seat of radiator cap.

A : Valve seat
B : Metal plunger

- Check that valve seat is swollen to the extent that the edge of the plunger cannot be seen when watching it vertically from the top.
- Check that valve seat has no soil and damage.

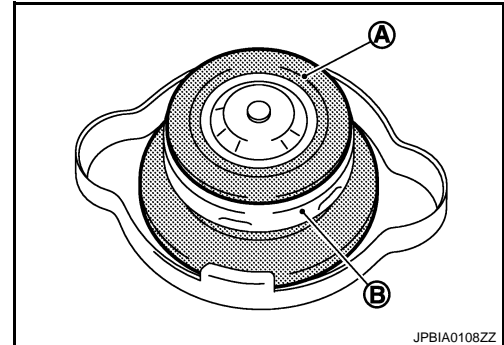

- Pull negative-pressure valve to open it, and check that it close completely when released.
- Check that there is no dirt or damage on the valve seat of radiator cap negative-pressure valve.
- Check that there are no unusualness in the opening and closing conditions of negative-pressure valve.

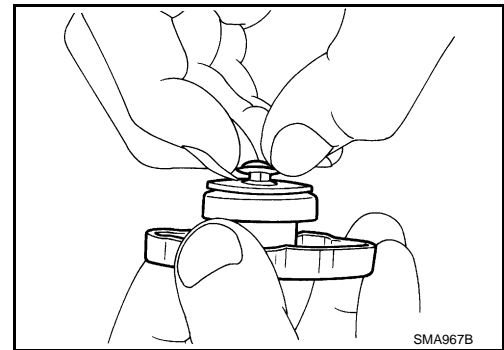

- Check radiator cap relief pressure.

Standard and Limit: Refer to [CO-28, "Radiator"](#).

- When connecting radiator cap to the radiator cap tester (commercial service tool) (A) and the radiator cap tester adapter (commercial service tool) (B), apply engine coolant to the cap seal surface.

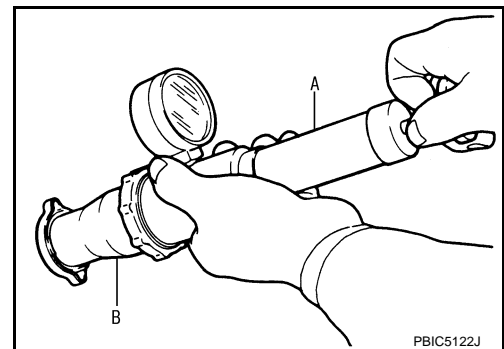

- Replace radiator cap if there is an unusualness related to the above three.

CAUTION:

When installing radiator cap, thoroughly wipe out the radiator filler neck to remove any waxy residue or foreign material.

RADIATOR

RADIATOR : Inspection

INFOID:000000001713803

Check radiator for mud or clogging. If necessary, clean radiator as follows.

CAUTION:

- **Be careful not to bend or damage radiator fins.**
 - **When radiator is cleaned without removal, remove all surrounding parts such as radiator cooling fan assembly and horns. Then tape harness and harness connectors to prevent water from entering.**
1. Apply water by hose to the back side of the radiator core vertically downward.
 2. Apply water again to all radiator core surfaces once per minute.
 3. Stop washing if any stains no longer flow out from radiator.

RADIATOR

< ON-VEHICLE MAINTENANCE >

4. Blow air into the back side of radiator core vertically downward.
 - Use compressed air lower than 490 kPa (5 kg/cm², 71 psi) and keep distance more than 30 cm (11.81 in).
5. Blow air again into all the radiator core surfaces once per minute until no water sprays out.

RADIATOR

< ON-VEHICLE REPAIR >

ON-VEHICLE REPAIR

RADIATOR

Exploded View

INFOID:000000001713804

REMOVAL

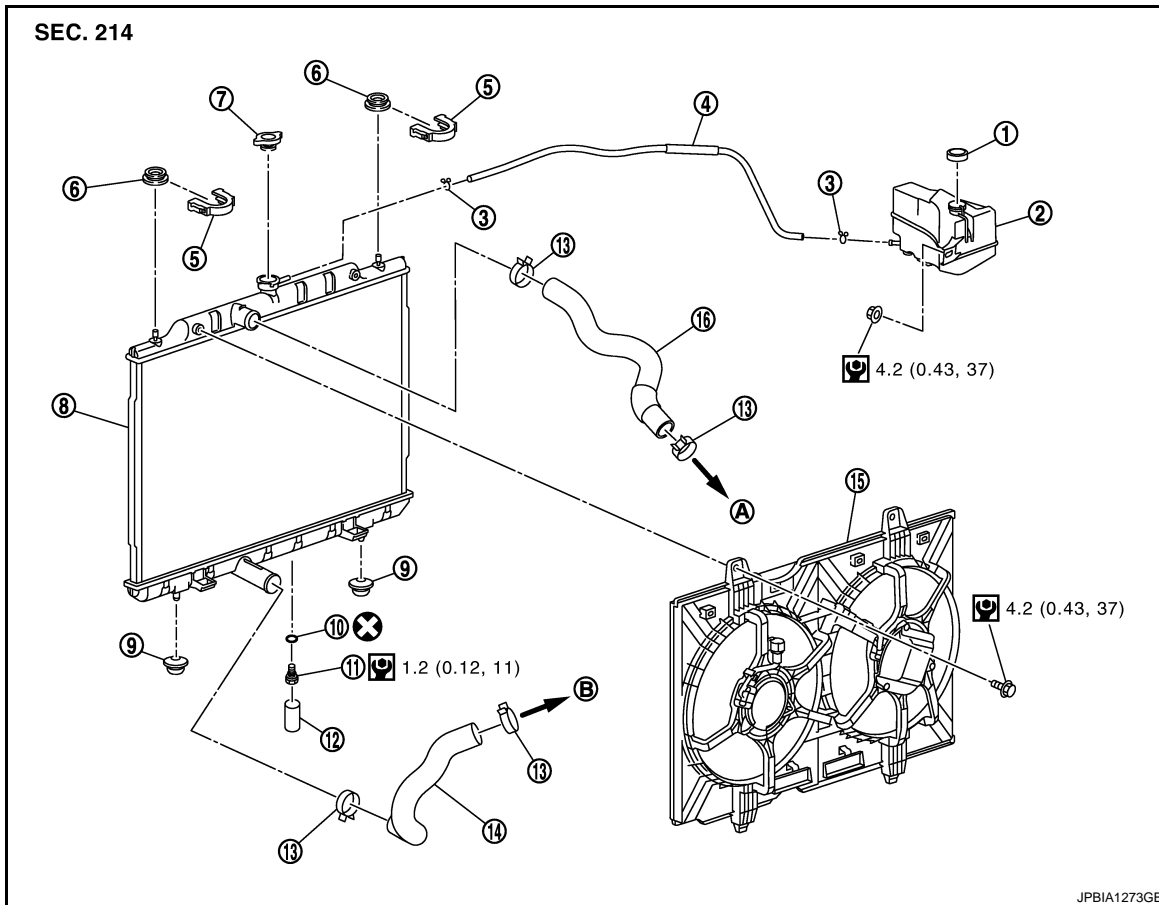

- | | | |
|---------------------------|---------------------------|----------------------------|
| 1. Reservoir tank cap | 2. Reservoir tank | 3. Clamp |
| 4. Reservoir tank hose | 5. Radiator upper clip | 6. Mounting rubber (upper) |
| 7. Radiator cap | 8. Radiator | 9. Mounting rubber (lower) |
| 10. O-ring | 11. Drain plug | 12. Water drain hose |
| 13. Clamp | 14. Radiator hose (lower) | 15. Cooling fan assembly |
| 16. Radiator hose (upper) | | |
| A. To water outlet | B. To water inlet | |

Refer to [GI-4, "Components"](#) for symbols in the figure.

DISASSEMBLY

RADIATOR

< ON-VEHICLE REPAIR >

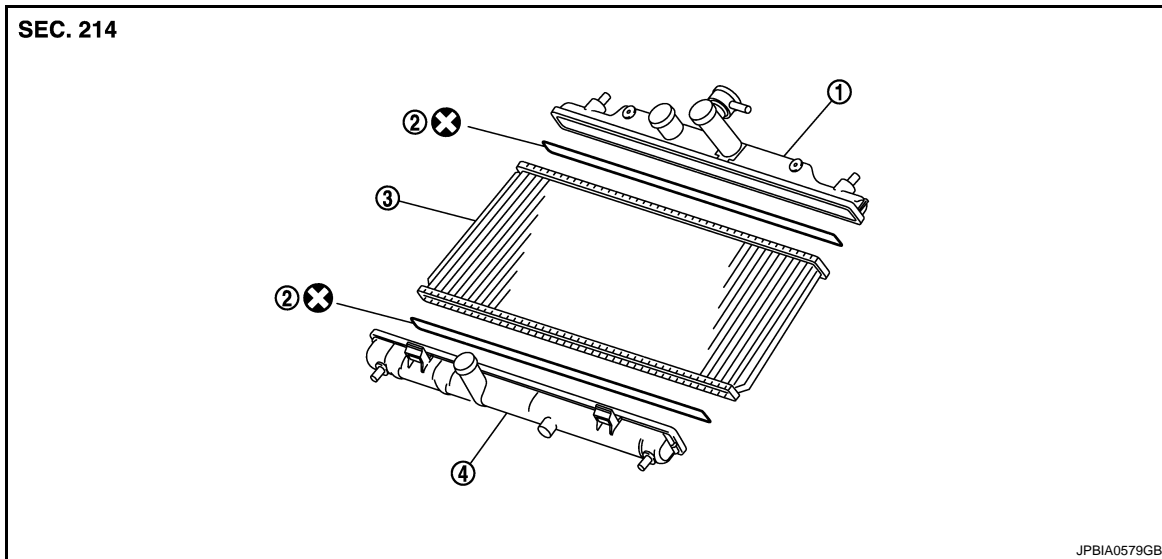

1. Upper tank
2. Sealing rubber
3. Core
4. Lower tank

Refer to [GI-4, "Components"](#) for symbols in the figure.

Removal and Installation

INFOID:000000001713805

REMOVAL

WARNING:

- Never remove radiator cap when engine is hot. Serious burns may occur from high-pressure engine coolant escaping from radiator.
- Wrap a thick cloth around the radiator cap. Slowly turn it a quarter of a turn to release built-up pressure. Then turn it all the way.

1. Remove engine under cover.
2. Drain engine coolant from radiator. Refer to [CO-9, "Draining"](#).
3. Remove air duct (inlet). Refer to [EM-27, "Exploded View"](#).
4. Remove radiator hose (upper) and reservoir tank hose.
5. Disconnect harness connector from fan motor, and move it aside.
6. Remove cooling fan assembly (1).

CAUTION:

Be careful not to damage radiator core when removing.

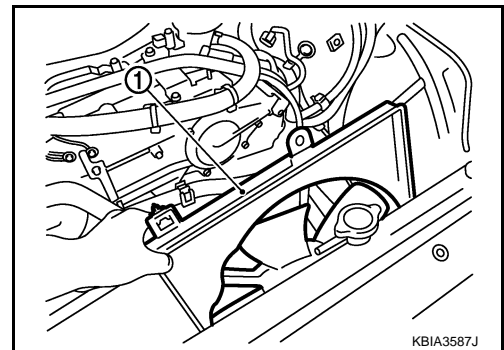

7. Removal radiator hose (lower).

RADIATOR

< ON-VEHICLE REPAIR >

- Remove radiator upper clips by pulling the tabs outside to release the lock.
Never pull the tabs outside excessively to prevent it from damaging.

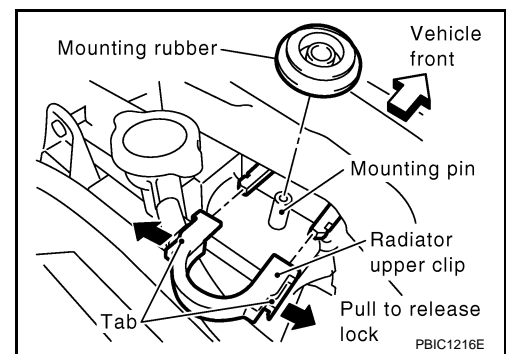

- Remove radiator.

CAUTION:

Be careful not to damage or scratch radiator core.

INSTALLATION

Note the following, and install in the reverse order of removal.

Radiator Upper Clip

Install radiator upper clip on radiator core connection as follows:

- Install mounting rubbers (upper) on mounting pins of radiator.

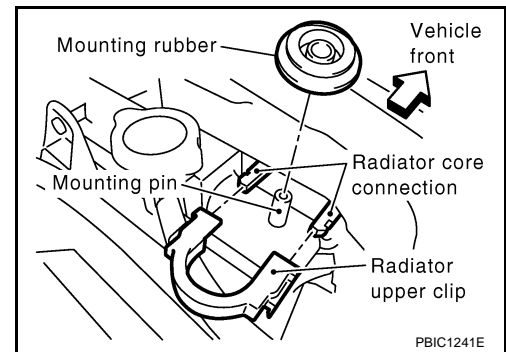

- Align radiator upper clip with radiator core connection, then insert radiator upper clip straight into radiator core connections until a click is heard.
- After connecting radiator upper clip, use the following method to make sure it is fully connected.
 - Visually confirm that two radiator upper clips are connected to radiator core connections.
 - Move radiator upper clip and the radiator forward and backward to check they are securely connected.

Disassembly and Assembly

INFOID:000000001713806

PREPARATION

- Attach spacer to tip of the radiator plate pliers A (SST).
Spacer specification: 1.5 mm (0.059 in) thick × 18 mm (0.71 in) wide × 8.5 mm (0.335 in) long.

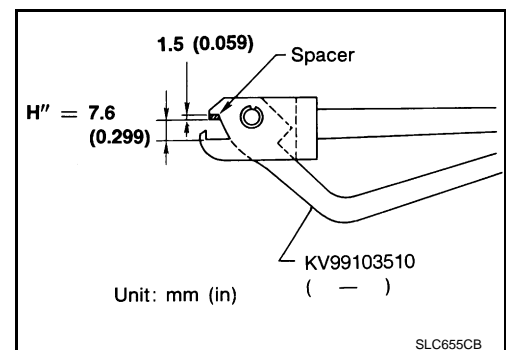

- Check that when the radiator plate pliers A [SST: KV99103510 (—)] are closed dimension H'' is approx. 7.6 mm (0.299 in).
- Adjust dimension H'' with spacer, if necessary.

DISASSEMBLY

RADIATOR

< ON-VEHICLE REPAIR >

1. Remove upper and lower tanks with the radiator plate pliers B (SST).

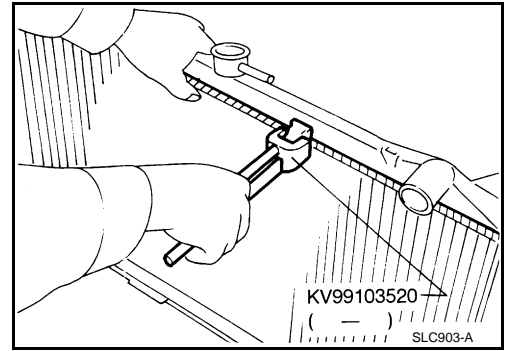

- Grip the crimped edge and bend it upwards so that the radiator plate pliers B [SST: KV99103520 (—)] slips off.

CAUTION:

Never bend excessively.

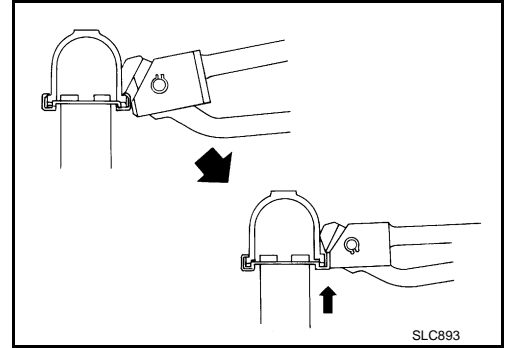

- In areas where the radiator plate pliers B [SST: KV99103520 (—)] cannot be used, use a screwdriver to bend the edge up.

CAUTION:

Be careful not to damage tank.

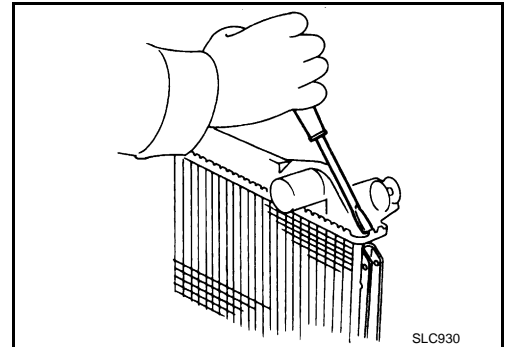

2. Remove sealing rubber.
3. Check the edge stands straight up.

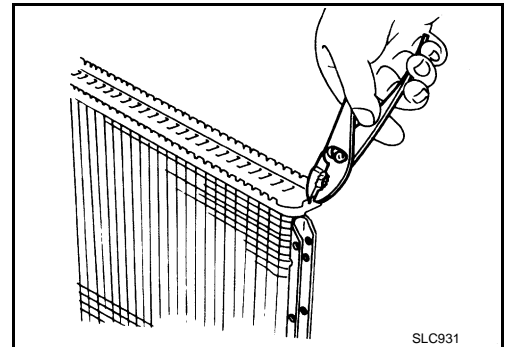

ASSEMBLY

RADIATOR

< ON-VEHICLE REPAIR >

1. Clean contact portion of tank.

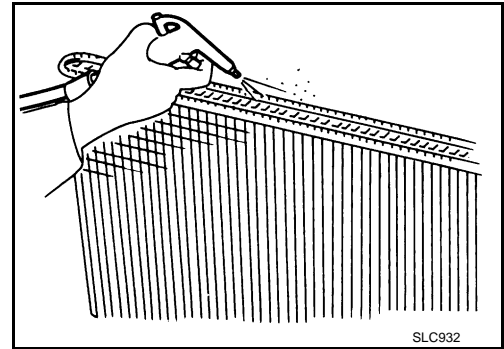

2. Install new sealing rubber while pressing it with fingers.

CAUTION:

Be careful not to twist sealing rubber.

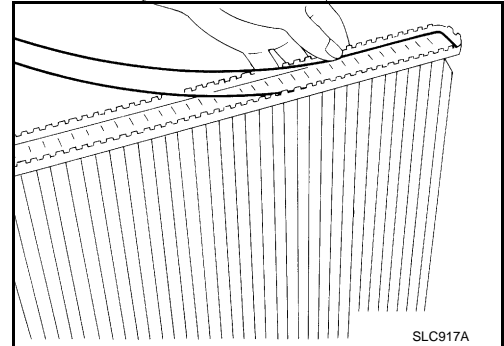

3. Caulk tank in numerical order as shown in the figure with the radiator plate pliers A (SST).

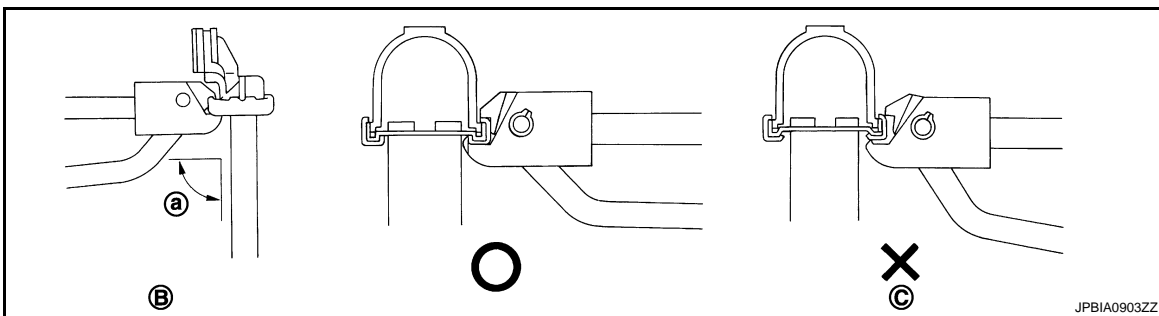
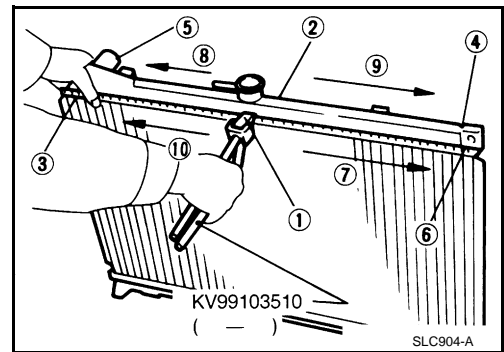

B. Keep tool perpendicular to the radiator C. Grip is insufficient

a. 90°

A
CO
C
D
E
F
G
H
I
J
K
L
M
N
O
P

RADIATOR

< ON-VEHICLE REPAIR >

- Use pliers in the locations where the radiator plate pliers A [SST: KV99103510 (—)] cannot be used.

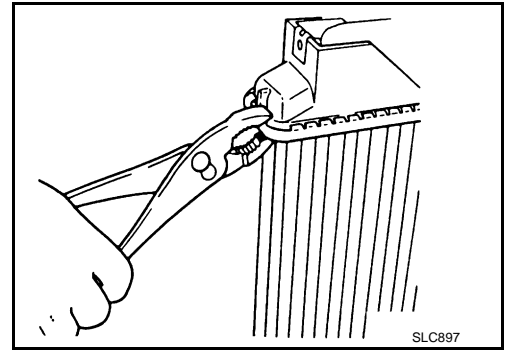

4. Check that the rim is completely crimped down.

Standard height "H" : 8.0 - 8.4 mm (0.315 - 0.331 in)

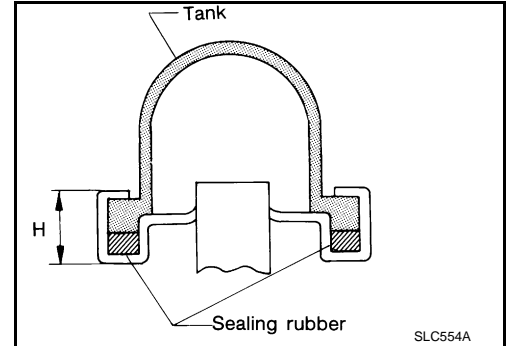

5. Check that there is no leakage. Refer to [CO-20, "Inspection"](#).

Inspection

INFOID:000000001713807

INSPECTION AFTER ASSEMBLY

1. Apply pressure with the radiator cap tester adapter (commercial service tool) (A) and the radiator cap tester (commercial service tool).

Testing pressure: Refer to [CO-28, "Radiator"](#).

WARNING:

To prevent the risk of hose coming undone while under pressure, securely fasten it down with hose clamp.

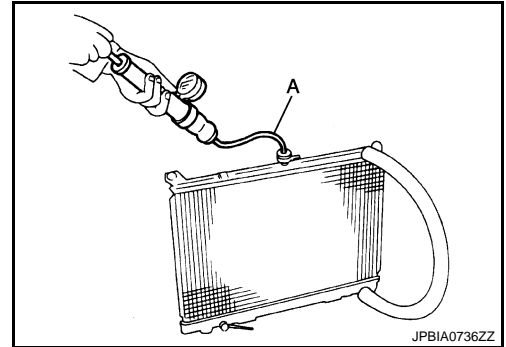

2. Check for leakage by soaking radiator in water container with the testing pressure applied.

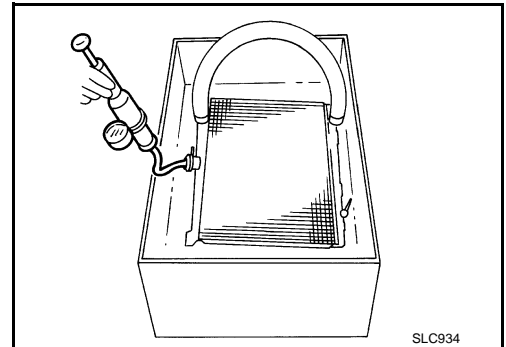

INSPECTION AFTER INSTALLATION

- Check for leakage of engine coolant using the radiator cap tester adapter (commercial service tool) and the radiator cap tester (commercial service tool). Refer to [CO-9, "Inspection"](#).
- Start and warm up the engine. Check visually that there is no leakage of engine coolant.

COOLING FAN

< ON-VEHICLE REPAIR >

COOLING FAN

Exploded View

INFOID:000000001713808

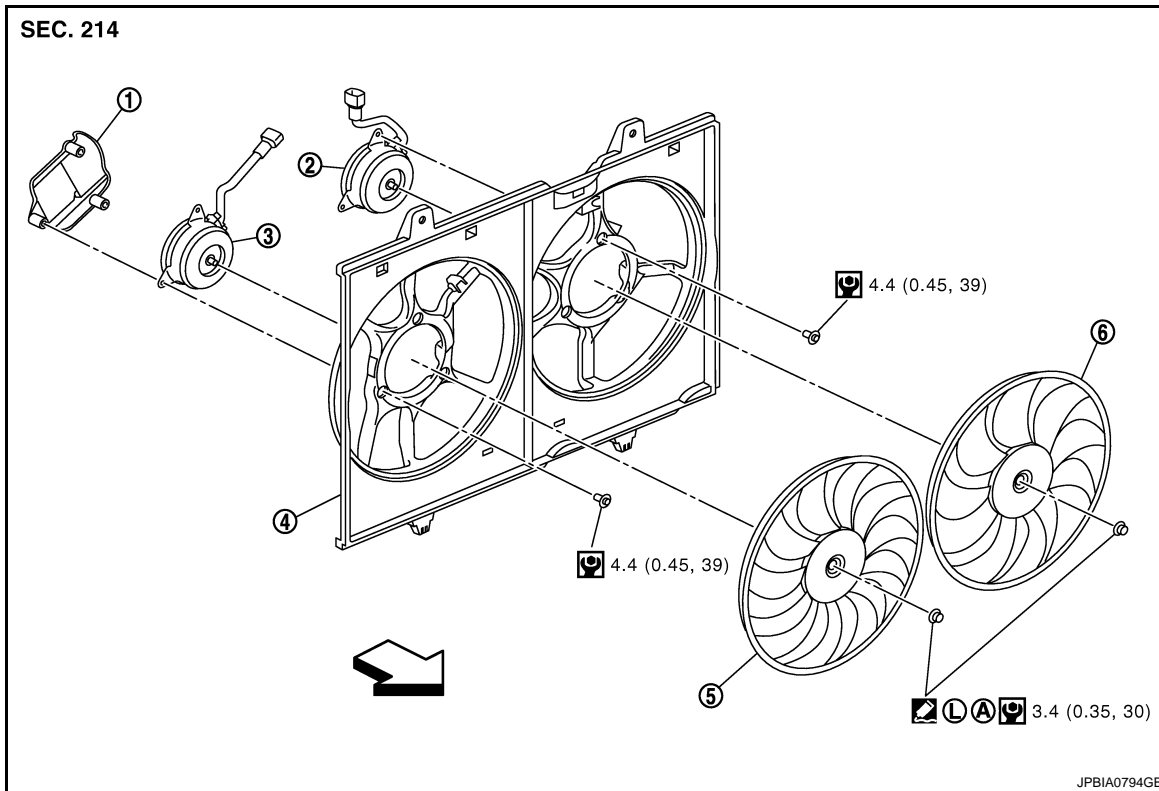

- | | | |
|--------------------|---------------------|---------------------|
| 1. Fan motor cover | 2. Fan motor (LH) | 3. Fan motor (RH) |
| 4. Fan shroud | 5. Cooling fan (RH) | 6. Cooling fan (LH) |

A. Apply on fan motor shaft.

← : Vehicle front

: Apply thread locking sealant.

Refer to [GI-4, "Components"](#) for symbols not described on the above.

Removal and Installation

INFOID:000000001713809

REMOVAL

1. Remove engine under cover.
2. Drain engine coolant from radiator. Refer to [CO-9, "Draining"](#).
CAUTION:
Perform this step when the engine is cold.
3. Remove air duct (inlet). Refer to [EM-27, "Exploded View"](#).
4. Remove radiator hose (upper) and reservoir tank hose. Refer to [CO-15, "Exploded View"](#).
5. Disconnect harness connector from fan motor, and move harness to aside.
6. Remove cooling fan assembly.
CAUTION:
Be careful not to damage or scratch on radiator core when removing.

INSTALLATION

Note the following, and install in the reverse order of removal.

CAUTION:

Only use genuine parts for radiator shroud and cooling fan mounting bolt and observe the specified torque (to prevent radiator from being damaged).

COOLING FAN

< ON-VEHICLE REPAIR >

NOTE:

Cooling fan is controlled by ECM. For details, refer to [EC-65. "System Diagram"](#) (for California), [EC-965. "System Diagram"](#) (for Mexico) or [EC-538. "System Diagram"](#) (Except for California and Mexico).

Disassembly and Assembly

INFOID:000000001713810

DISASSEMBLY

1. Remove cooling fan mounting nuts, and then remove the cooling fans (RH and LH).
2. Remove fan motor cover and fan motors (RH and LH).

ASSEMBLY

Note the following, and assemble in the reverse order of disassembly.

CAUTION:

RH and LH cooling fans are different. Be careful not to misassemble them.

- Install each fan in the following position.

Right side : 11 blades

Left side : 9 blades

- Apply thread locking sealant on fan motor shaft.

Inspection

INFOID:000000001713811

INSPECTION AFTER DISASSEMBLY

Cooling Fan

Inspect cooling fan for crack or unusual bend.

- If anything is found, replace cooling fan.

WATER PUMP

< ON-VEHICLE REPAIR >

WATER PUMP

Exploded View

INFOID:000000001713812

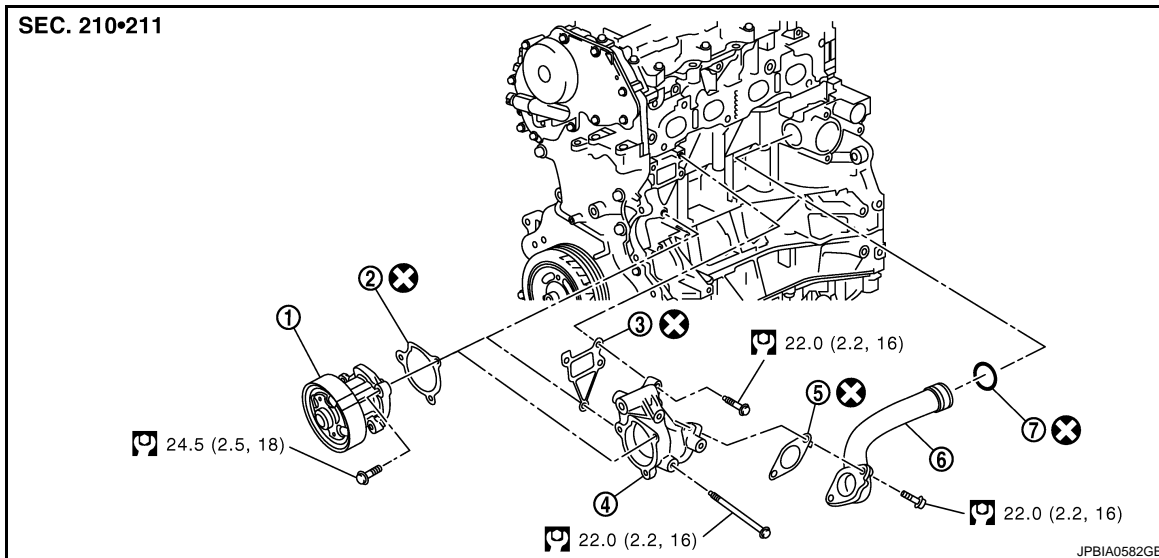

- | | | |
|-----------------------|-----------|---------------|
| 1. Water pump | 2. Gasket | 3. Gasket |
| 4. Water pump housing | 5. Gasket | 6. Water pipe |
| 7. O-ring | | |

Refer to [GI-4, "Components"](#) for symbols in the figure.

Removal and Installation

INFOID:000000001713813

REMOVAL

1. Drain engine coolant. Refer to [CO-9, "Draining"](#).
CAUTION:
Perform this step when engine is cold.
2. Remove the following parts.
 - Drive belt: Refer to [EM-15, "Removal and Installation"](#).
 - Drive belt auto-tensioner: Refer to [EM-25, "Exploded View"](#).
 - Alternator: Refer to [CHG-19, "Exploded View"](#).
3. Remove water pump.
 - Engine coolant leaks from cylinder block, so have a receptacle ready below.**CAUTION:**
 - **Handle water pump vane so that it does not contact any other parts.**
 - **Water pump cannot be disassembled and should be replaced as a unit.**
4. Remove water pump housing with the following procedure:
 - a. Remove exhaust manifold cover. Refer to [EM-32, "Exploded View"](#).
 - b. Remove oil level gauge and oil level gauge guide. Refer to [EM-34, "Exploded View"](#).
CAUTION:
Plug the oil level gauge guide opening to prevent oil pan from entering foreign materials.
 - c. Remove mounting bolts for water pipe.
 - d. Remove water pump housing.
5. Remove exhaust manifold and three way catalyst assembly. Refer to [EM-32, "Exploded View"](#).
6. Remove water pipe.

INSTALLATION

Note the following, and install in the reverse order of removal.

- When inserting water pipe end into cylinder block, apply a neutral detergent to O-ring. Then insert it immediately.

WATER PUMP

< ON-VEHICLE REPAIR >

Inspection

INFOID:000000001713814

INSPECTION AFTER REMOVAL

- Check visually that there is no significant dirt or rusting on water pump body and vane.
- Check that there is no looseness in vane shaft, and that it turns smoothly when rotated by hand.
- Replace water pump, if necessary.

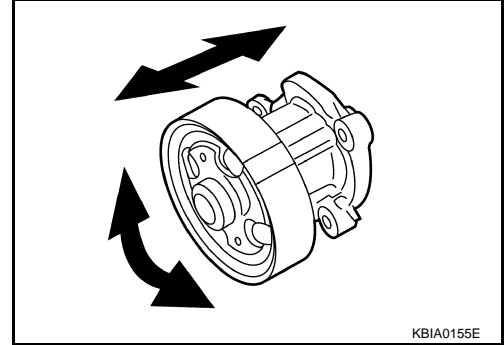

INSPECTION AFTER INSTALLATION

- Check for leakage of engine coolant using the radiator cap tester adapter (commercial service tool) and the radiator cap tester (commercial service tool). Refer to [CO-9, "Inspection"](#).
- Start and warm up engine. Check visually that there is no leakage of engine coolant.

THERMOSTAT AND WATER CONTROL VALVE

< ON-VEHICLE REPAIR >

THERMOSTAT AND WATER CONTROL VALVE

Exploded View

INFOID:000000001713815

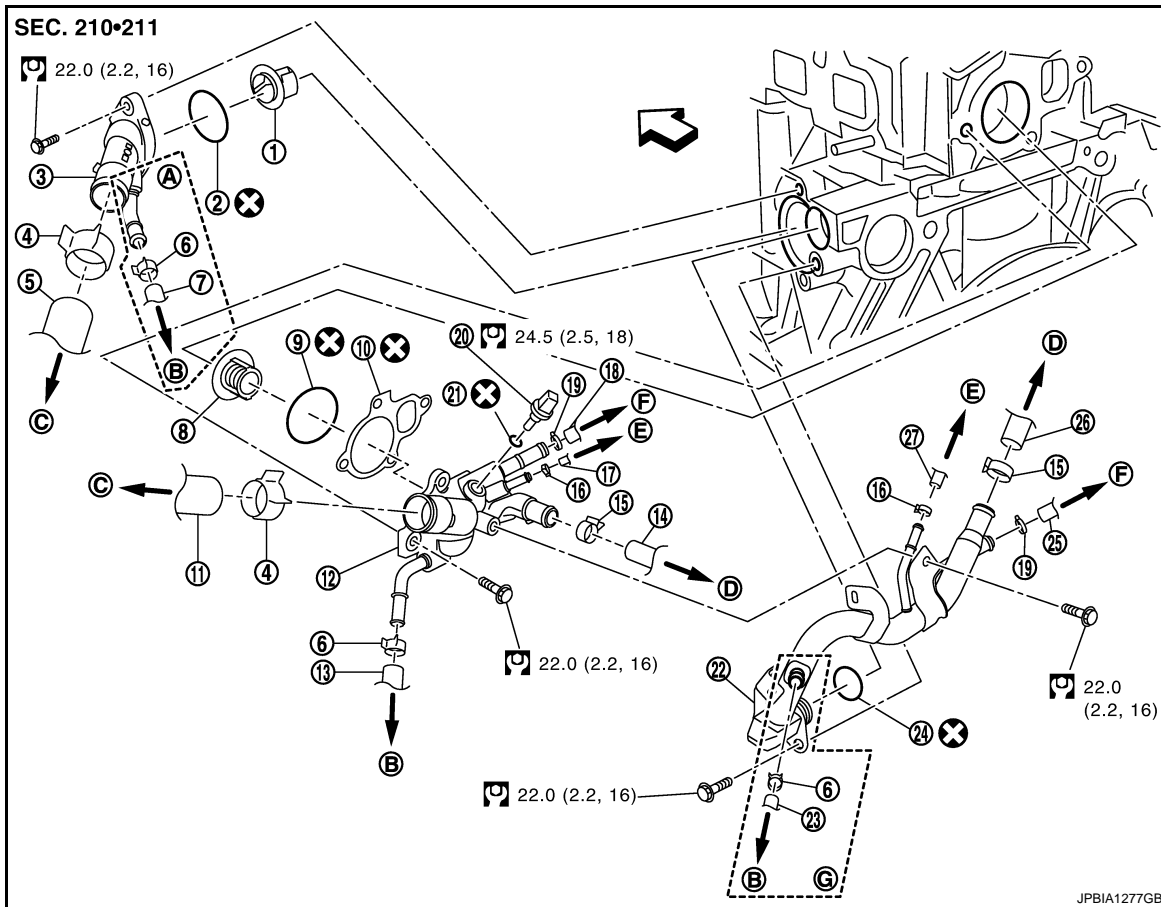

- | | | |
|-----------------|--|--|
| 1. Thermostat | 2. O-ring | 3. Water inlet |
| 4. Clamp | 5. Radiator hose (lower) | 6. Clamp |
| 7. Water hose | 8. Water control valve | 9. O-ring |
| 10. Gasket | 11. Radiator hose (upper) | 12. Water control valve housing (water outlet) |
| 13. Water hose | 14. Heater hose | 15. Clamp |
| 16. Clamp | 17. Water hose | 18. Water hose |
| 19. Clamp | 20. Engine coolant temperature sensor | 21. Washer |
| 22. Heater pipe | 23. Water hose | 24. O-ring |
| 25. Water hose | 26. Heater hose | 27. Water hose |
| A. Type 1 | B. To CVT fluid cooler | C. To radiator |
| D. To heater | E. To electric throttle control actuator | F. To oil cooler |
| G. Type 2 | | |

← : Engine front

Refer to [GI-4, "Components"](#) for symbols in the figure.

Removal and Installation

INFOID:000000001713816

REMOVAL

1. Remove battery. Refer to [PG-88, "Exploded View"](#).
2. Disconnect engine room harness connectors at unit sides TCM and ECM, and then move it to aside.

THERMOSTAT AND WATER CONTROL VALVE

< ON-VEHICLE REPAIR >

3. Remove battery tray.
4. Remove air duct and air cleaner case assembly. Refer to [EM-27, "Exploded View"](#).
5. Drain engine coolant. Refer to [CO-9, "Draining"](#).
CAUTION:
Perform this step when engine is cold.
6. Disconnect radiator hose (lower) at water inlet side. Refer to [CO-15, "Exploded View"](#).
7. Disconnect water hose at water inlet side. (Type 1)
8. Remove water inlet and thermostat.
9. Remove water control valve with the following procedure:
 - a. Disconnect radiator hose (upper) at water control valve housing (water outlet) side.
 - b. Disconnect harness connector from engine coolant temperature sensor.
 - c. Remove CVT fluid level gauge and CVT fluid charging pipe. Refer to [TM-207, "2WD : Exploded View"](#) (2WD models) or [TM-211, "AWD : Exploded View"](#) (AWD models).
 - d. Disconnect water hoses.
 - e. Disconnect air fuel ratio sensor 1 and heated oxygen sensor 2 harness connectors, and remove harness clips from heater pipe.
 - f. Remove heater pipe and heater hose.
 - g. After removing water control valve housing (water outlet), remove water control valve.

INSTALLATION

Note the following, and install in the reverse order of removal.

Thermostat and Water Control Valve

- Install thermostat and water control valve with making rubber ring (1) groove fit to thermostat flange and water control valve flange (A) with the whole circumference. (The example in the figure shows water control valve.)

NOTE:

Same procedure is applied for installation of thermostat.

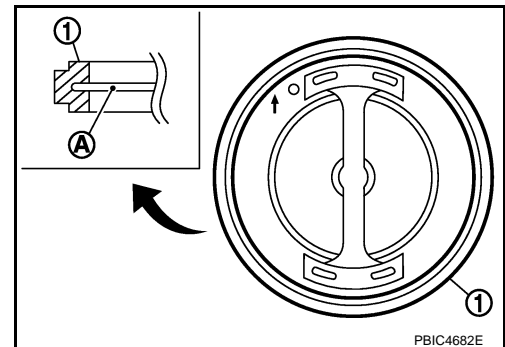

- Install thermostat with jiggle valve facing upwards. (The position deviation may be within the range of 20 degrees as shown in the figure.)
- Install water control valve with the arrow facing up and the frame center part facing upwards. (The position deviation may be within the range of 20 degrees as shown in the figure.)

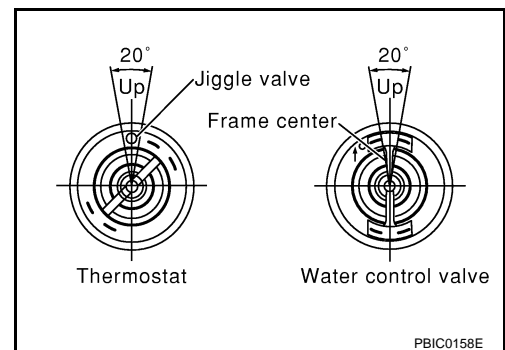

Heater Pipe Installation

Apply a neutral detergent to O-ring, then quickly insert the insertion part of heater pipe into cylinder block.

Inspection

INFOID:000000001713817

INSPECTION AFTER REMOVAL

THERMOSTAT AND WATER CONTROL VALVE

< ON-VEHICLE REPAIR >

- Place a thread (A) so that it is caught in the valves of thermostat (1) and water control valve. Immerse fully in a container (B) filled with water. Heat while stirring. (The example in the figure shows thermostat.)
- The valve opening temperature is the temperature at which the valve opens and falls from the thread.
- Continue heating. Check the maximum valve lift amount.

NOTE:

The maximum valve lift amount standard temperature for water control valve is the reference value.

- After checking the maximum valve lift amount, lower the water temperature and check the valve closing temperature.

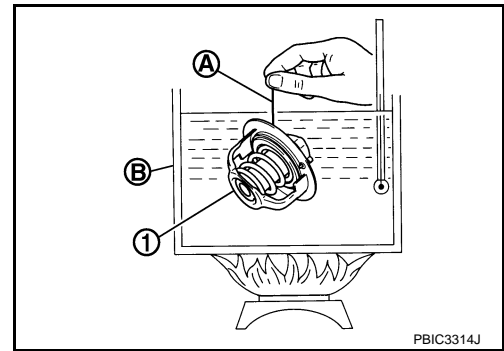

Standard

Thermostat : Refer to [CO-28, "Thermostat"](#).

Water control valve : Refer to [CO-28, "Water control valve"](#).

- If out of the standard, replace either or both thermostat and water control valve.

INSPECTION AFTER INSTALLATION

- Check for leakage of engine coolant using the radiator cap tester adapter (commercial service tool) and the radiator cap tester (commercial service tool). Refer to [CO-9, "Inspection"](#).
- Start and warm up engine. Check visually that there is no leakage of engine coolant.

A

CO

C

D

E

F

G

H

I

J

K

L

M

N

O

P

SERVICE DATA AND SPECIFICATIONS (SDS)

< SERVICE DATA AND SPECIFICATIONS (SDS)

SERVICE DATA AND SPECIFICATIONS (SDS)

SERVICE DATA AND SPECIFICATIONS (SDS)

Periodical Maintenance Specification

INFOID:000000001713818

ENGINE COOLANT CAPACITY (APPROXIMATE)

Unit: ℓ (US qt, Imp qt)

Engine coolant capacity (With reservoir tank at "MAX" level)	7.3 (7-3/4, 6-3/8)
Reservoir tank	0.75 (5/8)

Radiator

INFOID:000000001713819

Unit: kPa (kg/cm², psi)

Cap relief pressure	Standard	78.4 - 98.0 (0.8 - 1.0, 11- 14)
	Limit	59 (0.6, 9)
Leakage test pressure		157 (1.60, 22.8)

Thermostat

INFOID:000000001713820

Standard

Valve opening temperature	80.5 - 83.5°C (177 - 182°F)
Maximum valve lift	8 mm/95°C (0.315 in/203°F)
Valve closing temperature	77°C (171°F)

Water control valve

INFOID:000000001713821

Standard

Valve opening temperature	93.5 - 96.5°C (200 - 206°F)
Maximum valve lift	8 mm/108°C (0.315 in/226°F)*
Valve closing temperature	90°C (194°F)

*: Reference data