

A
B

SECTION HA

HEATER & AIR CONDITIONING SYSTEM

CONTENTS

BASIC INSPECTION		F
DIAGNOSIS AND REPAIR WORKFLOW		
Work Flow		
FUNCTION DIAGNOSIS		
REFRIGERATION SYSTEM		
System Diagram		
System Description		
Component Parts Location		
Component Description		
SYMPTOM DIAGNOSIS		
REFRIGERATION SYSTEM SYMPTOMS		
Trouble Diagnosis For Unusual Pressure		
Symptom Table		
COMPRESSOR SYSTEM SYMPTOMS		
Symptom Table		
PRECAUTION		
PRECAUTIONS		
FOR USA AND CANADA		
FOR USA AND CANADA : Precaution for Supplemental Restraint System (SRS) "AIR BAG" and "SEAT BELT PRE-TENSIONER"		
FOR USA AND CANADA : Precaution Necessary for Steering Wheel Rotation After Battery Disconnect		
FOR USA AND CANADA : Precaution for Procedure without Cowl Top Cover		
FOR USA AND CANADA : Precautions For Xenon Headlamp Service		
FOR USA AND CANADA : Working with HFC-134a (R-134a)		
FOR USA AND CANADA : General Refrigerant Precaution		
FOR USA AND CANADA : Refrigerant Connection		
FOR USA AND CANADA : Service Equipment		
FOR USA AND CANADA : Refrigerant Connection		
FOR USA AND CANADA : Service Equipment		
FOR MEXICO		
FOR MEXICO : Precaution for Supplemental Restraint System (SRS) "AIR BAG" and "SEAT BELT PRE-TENSIONER"		
FOR MEXICO : Precaution Necessary for Steering Wheel Rotation After Battery Disconnect		
FOR MEXICO : Precaution for Procedure without Cowl Top Cover		
FOR MEXICO : Precautions For Xenon Headlamp Service		
FOR MEXICO : Working with HFC-134a (R-134a)		
FOR MEXICO : General Refrigerant Precaution		
FOR MEXICO : Refrigerant Connection		
FOR MEXICO : Service Equipment		
COMPRESSOR		
General Precautions		
FLUORESCENT LEAK DETECTOR		
General Precautions		
PREPARATION		
PREPARATION		
Special Service Tool		
Commercial Service Tool		
Sealant or/and Lubricant		
ON-VEHICLE MAINTENANCE		
LUBRICANT		
Maintenance of Lubricant Quantity		
Lubricant Adjusting Procedure for Components Replacement Except Compressor		
Lubricant Adjusting Procedure for Compressor Replacement		
REFRIGERATION SYSTEM		



Inspection	33	CONDENSER	50
Performance Chart	33	Exploded View	50
Refrigerant Leakages	34	Removal and Installation	50
FLUORESCENT LEAK DETECTOR	35	LIQUID TANK	52
Inspection	35	Exploded View	52
ELECTRICAL LEAK DETECTOR	36	Removal and Installation	52
Inspection	36	REFRIGERANT PRESSURE SENSOR	53
ON-VEHICLE REPAIR	39	Exploded View	53
REFRIGERATION SYSTEM	39	Removal and Installation	53
Exploded View	39	EVAPORATOR	54
Inspection After Installation	39	Exploded View	54
COMPRESSOR	42	Removal and Installation	55
Exploded View	42	EXPANSION VALVE	56
Removal and Installation	42	Exploded View	56
Inspection	43	Removal and Installation	57
LOW-PRESSURE FLEXIBLE HOSE	44	SERVICE DATA AND SPECIFICATIONS	
Exploded View	44	(SDS)	58
Removal and Installation	44	SERVICE DATA AND SPECIFICATIONS	
HIGH-PRESSURE FLEXIBLE HOSE	46	(SDS)	58
Exploded View	46	Compressor	58
Removal and Installation	46	Lubricant	58
HIGH-PRESSURE PIPE	48	Refrigerant	58
Exploded View	48	Engine Idling Speed	58
Removal and Installation	48	Belt Tension	58

DIAGNOSIS AND REPAIR WORKFLOW

< BASIC INSPECTION >

BASIC INSPECTION

DIAGNOSIS AND REPAIR WORKFLOW

Work Flow

INFOID:000000001722419

DETAILED FLOW

1. LISTEN TO CUSTOMER COMPLAINT

Listen to customer complaint. (Get detailed information about the conditions and environment when the symptom occurs.)

>> GO TO 2.

2. VERIFY THE SYMPTOM WITH OPERATIONAL CHECK

Verify the symptom with operational check. Refer to [HAC-4, "Description & Inspection"](#).

>> GO TO 3.

3. GO TO APPROPRIATE TROUBLE DIAGNOSIS

Go to appropriate trouble diagnosis (Refer to [HAC-63, "Diagnosis Chart By Symptom"](#) below).

>> GO TO 4.

4. REPAIR OR REPLACE

Repair or replace the specific parts.

>> GO TO 5.

5. FINAL CHECK

Final check.

Is the inspection result normal?

YES >> CHECK OUT

NO >> GO TO 3.

A
B
C
D
E
F
G
H
HA
J
K
L
M
N
O
P

REFRIGERATION SYSTEM

< FUNCTION DIAGNOSIS >

FUNCTION DIAGNOSIS

REFRIGERATION SYSTEM

System Diagram

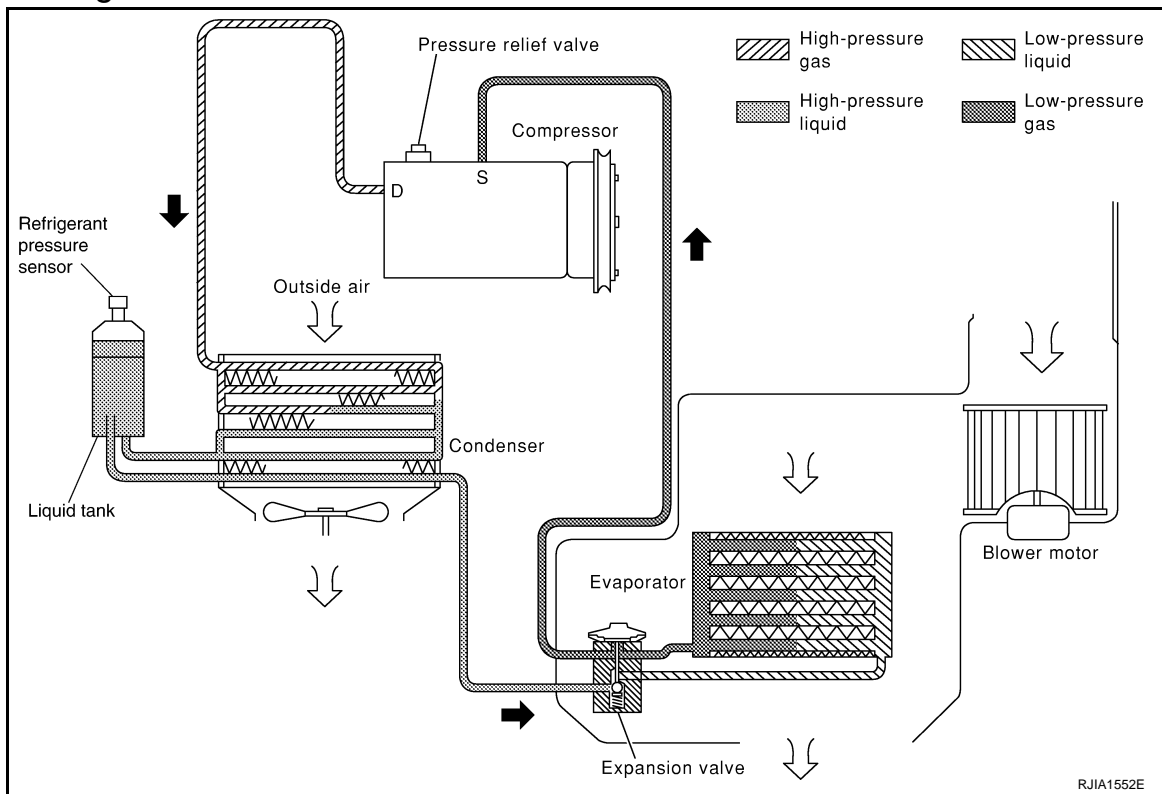

System Description

INFOID:000000001722421

REFRIGERANT CYCLE

Refrigerant Flow

The refrigerant flows from the compressor, through the condenser with liquid tank, through the evaporator, and back to the compressor. The refrigerant evaporation in the evaporator is controlled by an externally equalized expansion valve, located inside the evaporator case.

Freeze Protection

To prevent evaporator from freezing up, the evaporator air temperature is monitored, and the voltage signal to the A/C amp. makes the A/C relay go OFF and stop the compressor.

REFRIGERANT SYSTEM PROTECTION

Refrigerant Pressure Sensor

The refrigerant system is protected against excessively high- or low-pressures by the refrigerant pressure sensor, located on the liquid tank. The refrigerant pressure sensor detects the pressure inside the refrigerant line and sends the voltage signal to the ECM if the system pressure rises above, or falls below the specifications. ECM makes the A/C relay go OFF and stops the compressor when pressure on the high-pressure side detected by refrigerant pressure sensor is over approximately 3,120 kPa (31.20 bar, 31.8 kg/cm², 452 psi), or below approximately 140 kPa (1.40 bar, 1.4 kg/cm², 20 psi).

Pressure Relief Valve

The refrigerant system is also protected by a pressure relief valve, located in the rear head of the compressor. The release port on the pressure relief valve automatically opens and releases refrigerant into the atmosphere when the pressure of refrigerant in the system increases to an unusual level [more than 3.6 MPa (36 bar, 36.7 kg/cm², 522 psi)].

REFRIGERATION SYSTEM

< FUNCTION DIAGNOSIS >

Component Parts Location

INFOID:000000001722422

ENGINE COMPARTMENT

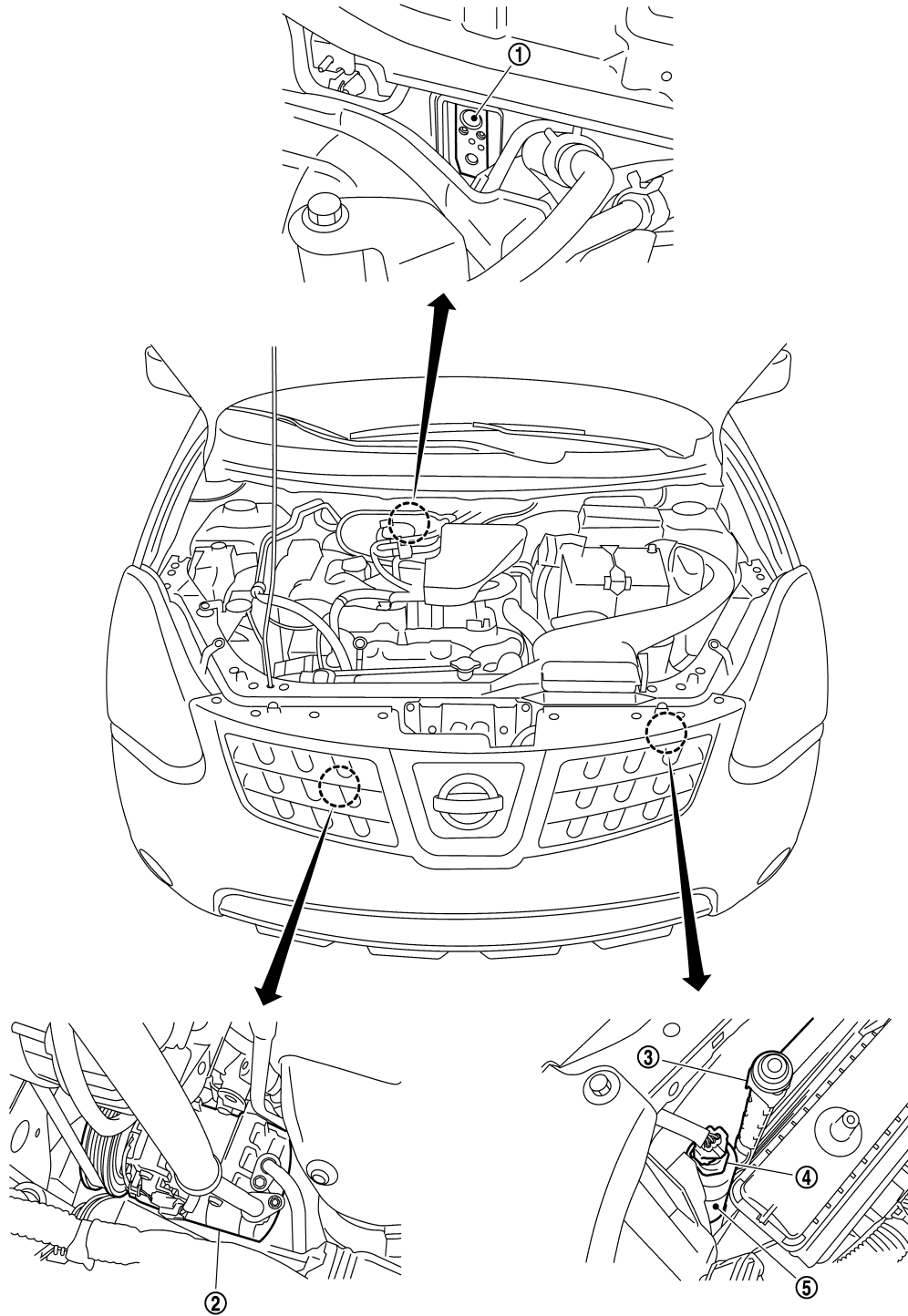

1. Expansion valve

4. Refrigerant pressure sensor

2. Compressor

5. Liquid tank

3. Condenser

PASSENGER COMPARTMENT

A
B
C
D
E
F
G
H
HA
J
K
L
M
N
O
P

REFRIGERATION SYSTEM

< FUNCTION DIAGNOSIS >

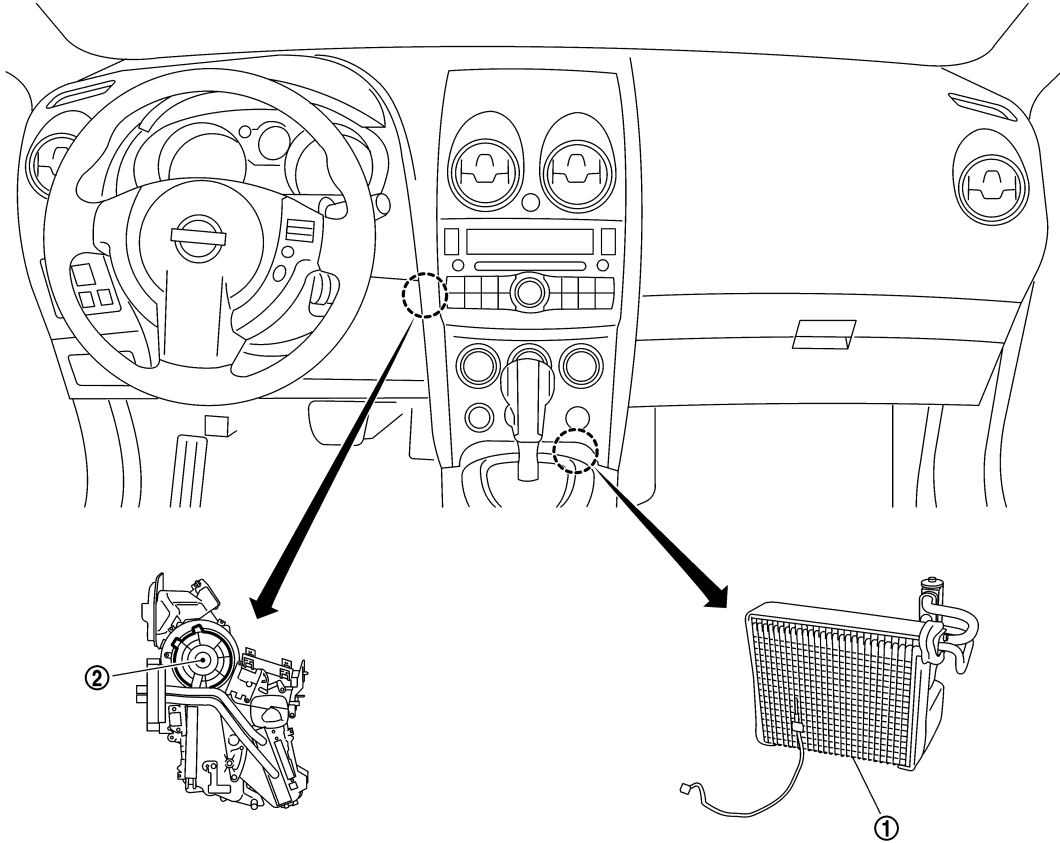

JSIA0835ZZ

1. Evaporator

2. Blower motor

Component Description

INFOID:000000001722423

Component	Description
Compressor	Intakes, compresses, and discharges refrigerant, to circulate refrigerant inside the refrigerant cycle.
Condenser	Cools refrigerant discharged from compressor, and transforms it to liquid refrigerant.
Liquid tank	Eliminates foreign matter in refrigerant, and stores temporarily liquid refrigerant.
Refrigerant pressure sensor	Refer to EC-434. "Description" (FOR CALIFORNIA), EC-865. "Description" [FOR USA (FEDERAL) AND CANADA] or EC-1222. "Description" (FOR MEXICO).
Expansion valve	Transforms high-pressure liquid refrigerant to mist form low-pressure liquid refrigerant by drawing function.
Evaporator	The mist form liquid refrigerant transforms to gas by evaporation by the air conveyed from blower motor. The air is cooled by the heat by evaporation.
Blower motor	Takes in air in the vehicle or fresh outside air, provides it forcedly to the air conditioner, and conveys it inside the vehicle.

REFRIGERATION SYSTEM SYMPTOMS

< SYMPTOM DIAGNOSIS >

SYMPTOM DIAGNOSIS

REFRIGERATION SYSTEM SYMPTOMS

Trouble Diagnosis For Unusual Pressure

INFOID:000000001722424

Diagnose using a manifold gauge whenever system's high and/or low side pressure(s) is/are unusual. The marker above the gauge scale in the following tables indicates the standard (usual) pressure range. Refer to above table (Ambient air temperature-to-operating pressure table) since the standard (usual) pressure, however, differs from vehicle to vehicle.

Symptom Table

INFOID:000000001722425

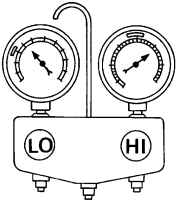
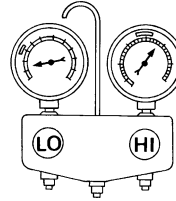
Gauge indication	Refrigerant cycle	Probable cause	Corrective action
<p>Both high- and low-pressure sides are too high.</p>  <p>AC359A</p>	<p>The pressure returns to normal is reduced soon after water is splashed on condenser.</p>	<p>Excessive refrigerant charge in refrigeration cycle.</p>	<p>Reduce refrigerant until specified pressure is obtained.</p>
	<p>Air suction by cooling fan is insufficient.</p>	<p>Insufficient condenser cooling performance. ↓ 1. Condenser fins are clogged. 2. Improper fan rotation of cooling fan.</p>	<ul style="list-style-type: none"> Clean condenser. Check and repair cooling fan if necessary.
	<ul style="list-style-type: none"> Low-pressure pipe is not cold. When compressor is stopped high-pressure reading quickly drops by approximately 196 kPa (1.96 bar, 2 kg/cm², 28 psi). It then decreases gradually thereafter. 	<p>Poor heat exchange in condenser (After compressor operation stops, high-pressure decreases too slowly). ↓ Air in refrigeration cycle.</p>	<p>Evacuate repeatedly and re-charge system.</p>
	<p>Engine tends to overheat.</p>	<p>Engine cooling systems malfunction.</p>	<p>Check and repair each engine cooling system.</p>
	<ul style="list-style-type: none"> An area of the low-pressure pipe is colder than areas near the evaporator outlet. Low-pressure pipe is sometimes covered with frost. 	<ul style="list-style-type: none"> Excessive liquid refrigerant on low-pressure side. Excessive refrigerant discharge flow. Expansion valve is open a little compared with the specification. <p>↓ Improper expansion valve adjustment.</p>	<p>Replace expansion valve.</p>
<p>High-pressure side is too high and low-pressure side is too low.</p>  <p>AC360A</p>	<p>Upper side of condenser and high-pressure side are hot, however, liquid tank is not so hot.</p>	<p>High-pressure tube or parts located between compressor and condenser are clogged or crushed.</p>	<ul style="list-style-type: none"> Check and repair or replace malfunctioning parts. Check lubricant for contamination.

REFRIGERATION SYSTEM SYMPTOMS

< SYMPTOM DIAGNOSIS >

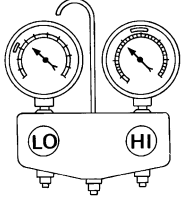
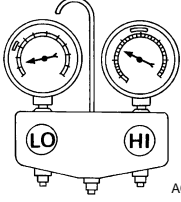
Gauge indication	Refrigerant cycle	Probable cause	Corrective action
High-pressure side is too low and low-pressure side is too high.  AC356A	High- and low-pressure sides become equal soon after compressor operation stops.	Compressor pressure operation is improper. ↓ Damaged inside compressor packings.	Replace compressor.
	No temperature difference between high- and low-pressure sides.	Compressor pressure operation is improper. ↓ Damaged inside compressor packings.	Replace compressor.
Both high- and low-pressure sides are too low.  AC353A	<ul style="list-style-type: none"> • There is a big temperature difference between liquid tank outlet and inlet. Outlet temperature is extremely low. • Liquid tank inlet and expansion valve are frosted. 	Liquid tank inside is slightly clogged.	<ul style="list-style-type: none"> • Replace liquid tank. • Check lubricant for contamination.
	<ul style="list-style-type: none"> • Expansion valve inlet temperature is extremely low as compared with areas near liquid tank. • Expansion valve inlet is frosted. • Temperature difference occurs somewhere in high-pressure side. 	High-pressure pipe located between liquid tank and expansion valve is clogged.	<ul style="list-style-type: none"> • Check and repair malfunctioning parts. • Check lubricant for contamination.
	Expansion valve and liquid tank are warm or slightly cool when touched.	Low refrigerant charge. ↓ Leaking fittings or components.	Check refrigerant for leaks. Refer to HA-34, "Refrigerant Leakages" .
	There is a big temperature difference between expansion valve inlet and outlet while the valve itself is frosted.	Expansion valve closes a little compared with the specification. ↓ 1. Improper expansion valve adjustment. 2. Malfunctioning expansion valve. 3. Outlet and inlet may be clogged.	<ul style="list-style-type: none"> • Remove foreign particles by using compressed air. • Replace expansion valve. • Check lubricant for contamination.
	An area of the low-pressure pipe is colder than areas near the evaporator outlet.	Low-pressure pipe is clogged or crushed.	<ul style="list-style-type: none"> • Check and repair malfunctioning parts. • Check lubricant for contamination.
	Air flow volume is not enough or is too low.	Evaporator is frozen.	<ul style="list-style-type: none"> • Check intake sensor circuit. Refer to HAC-36, "Diagnosis Procedure". • Replace compressor. • Repair evaporator fins. • Replace evaporator. • Check blower motor circuit. Refer to HAC-28, "Diagnosis Procedure".

REFRIGERATION SYSTEM SYMPTOMS

< SYMPTOM DIAGNOSIS >

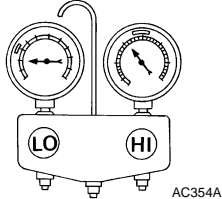
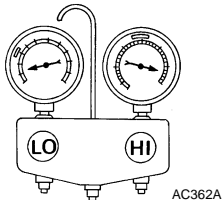
Gauge indication	Refrigerant cycle	Probable cause	Corrective action
<p>Low-pressure side sometimes becomes negative.</p>  <p style="text-align: right; font-size: small;">AC354A</p>	<ul style="list-style-type: none"> • Air conditioning system does not function and does not cyclically cool the compartment air. • The system constantly functions for a period of time after compressor is stopped and restarted. 	<p>Refrigerant does not discharge cyclically.</p> <p>↓</p> <p>Moisture is frozen at expansion valve outlet and inlet.</p> <p>↓</p> <p>Water is mixed with refrigerant.</p>	<ul style="list-style-type: none"> • Drain water from refrigerant or replace refrigerant. • Replace liquid tank.
<p>Low-pressure side becomes negative.</p>  <p style="text-align: right; font-size: small;">AC362A</p>	<p>Liquid tank or front/rear side of expansion valve's pipe is frosted or wet with dew.</p>	<p>High-pressure side is closed and refrigerant does not flow.</p> <p>↓</p> <p>Expansion valve or liquid tank is frosted.</p>	<p>Leave the system at rest until no frost is present. Start it again to check whether or not the malfunction is caused by water or foreign particles.</p> <ul style="list-style-type: none"> • Cooling is initially okay if water is the cause. Then the water freezes causing a blockage. Drain water from refrigerant or replace refrigerant. • Remove expansion valve and remove the particles with dry and compressed air (not shop air) if due to foreign particles. • Replace expansion valve if either of the above methods cannot correct the malfunction. • Replace liquid tank. • Check lubricant for contamination.

A
B
C
D
E
F
G
H
HA
J
K
L
M
N
O
P

COMPRESSOR SYSTEM SYMPTOMS

< SYMPTOM DIAGNOSIS >

COMPRESSOR SYSTEM SYMPTOMS

Symptom Table

INFOID:000000001722426

Follow the next table and perform trouble diagnosis if there is a compressor unit malfunction (internal noise, insufficient cooling).

Symptom	Inspection method	Check list	Result	Action
Noise from compressor unit When A/C is ON. (rattling or rolling sound)	Cooler system internal pressure	Check with manifold gauge	Both high- and low-pressure sides are high.*2	Recharge with proper amount of refrigerant.
			High/low-pressures hunt.*2	Replace compressor only.
	Check compressor oil condition.	Sample compressor oil and judge.	Refer to the criteria shown in compressor lubricant.	Diagnostic result 1: Replace compressor only. Diagnostic result 2: Replace compressor and liquid tank.
Insufficient cooling*1	Compressor body	Check rotation of compressor. If sized or stuck, sample compressor oil and judge.		
	Cooler system internal pressure	Check with a manifold gauge. Sample compressor oil and judge if the difference between high-pressure and low-pressure is small or if they are almost the same.		
Outlet air temperature rises temporarily while driving.*2	—	—	—	Replace compressor only.

*1: First conduct inspection according to trouble diagnosis for each malfunction.

*2: Applicable to variable capacity compressor only.

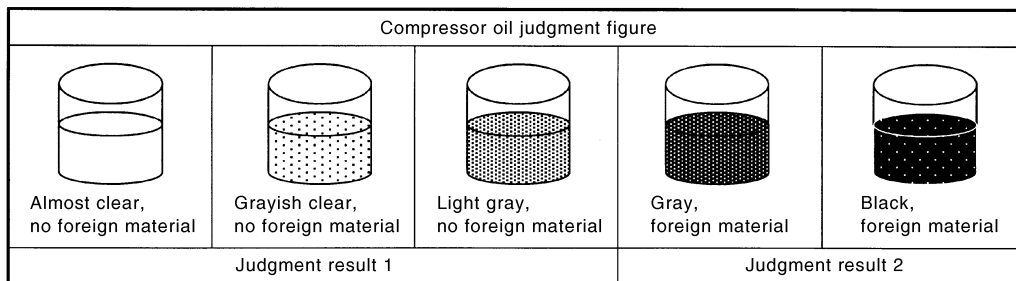

JSIIA0927GB

PRECAUTIONS

< PRECAUTION >

PRECAUTION

PRECAUTIONS FOR USA AND CANADA

FOR USA AND CANADA : Precaution for Supplemental Restraint System (SRS) "AIR BAG" and "SEAT BELT PRE-TENSIONER"

INFOID:000000003248334

The Supplemental Restraint System such as "AIR BAG" and "SEAT BELT PRE-TENSIONER", used along with a front seat belt, helps to reduce the risk or severity of injury to the driver and front passenger for certain types of collision. This system includes seat belt switch inputs and dual stage front air bag modules. The SRS system uses the seat belt switches to determine the front air bag deployment, and may only deploy one front air bag, depending on the severity of a collision and whether the front occupants are belted or unbelted. Information necessary to service the system safely is included in the "SRS AIRBAG" and "SEAT BELT" of this Service Manual.

WARNING:

- To avoid rendering the SRS inoperative, which could increase the risk of personal injury or death in the event of a collision which would result in air bag inflation, all maintenance must be performed by an authorized NISSAN/INFINITI dealer.
- Improper maintenance, including incorrect removal and installation of the SRS, can lead to personal injury caused by unintentional activation of the system. For removal of Spiral Cable and Air Bag Module, see the "SRS AIRBAG".
- Do not use electrical test equipment on any circuit related to the SRS unless instructed to in this Service Manual. SRS wiring harnesses can be identified by yellow and/or orange harnesses or harness connectors.

FOR USA AND CANADA : Precaution Necessary for Steering Wheel Rotation After Battery Disconnect

INFOID:000000003248342

NOTE:

- This Procedure is applied only to models with Intelligent Key system and NVIS/IVIS (NISSAN/INFINITI VEHICLE IMMOBILIZER SYSTEM - NATS).
- Remove and install all control units after disconnecting both battery cables with the ignition knob in the "LOCK" position.
- Always use CONSULT-III to perform self-diagnosis as a part of each function inspection after finishing work. If DTC is detected, perform trouble diagnosis according to self-diagnostic results.

For models equipped with the Intelligent Key system and NVIS/IVIS, an electrically controlled steering lock mechanism is adopted on the key cylinder.

For this reason, if the battery is disconnected or if the battery is discharged, the steering wheel will lock and steering wheel rotation will become impossible.

If steering wheel rotation is required when battery power is interrupted, follow the procedure below before starting the repair operation.

OPERATION PROCEDURE

1. Connect both battery cables.

NOTE:

Supply power using jumper cables if battery is discharged.

2. Use the Intelligent Key or mechanical key to turn the ignition switch to the "ACC" position. At this time, the steering lock will be released.
3. Disconnect both battery cables. The steering lock will remain released and the steering wheel can be rotated.
4. Perform the necessary repair operation.
5. When the repair work is completed, return the ignition switch to the "LOCK" position before connecting the battery cables. (At this time, the steering lock mechanism will engage.)
6. Perform a self-diagnosis check of all control units using CONSULT-III.

PRECAUTIONS

< PRECAUTION >

FOR USA AND CANADA : Precaution for Procedure without Cowl Top Cover

INFOID:000000003248350

When performing the procedure after removing cowl top cover, cover the lower end of windshield with urethane, etc.

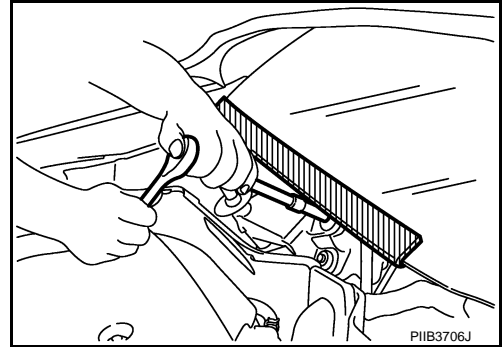

FOR USA AND CANADA : Precautions For Xenon Headlamp Service

INFOID:000000003248355

WARNING:

Comply with the following warnings to prevent any serious accident.

- Disconnect the battery cable (negative terminal) or the power supply fuse before installing, removing, or touching the xenon headlamp (bulb included). The xenon headlamp contains high-voltage generated parts.
- Never work with wet hands.
- Check the xenon headlamp ON-OFF status after assembling it to the vehicle. Never turn the xenon headlamp ON in other conditions. Connect the power supply to the vehicle-side connector. (Turning it ON outside the lamp case may cause fire or visual impairments.)
- Never touch the bulb glass immediately after turning it OFF. It is extremely hot.

CAUTION:

Comply with the following cautions to prevent any error and malfunction.

- Install the xenon bulb securely. (Insufficient bulb socket installation may melt the bulb, the connector, the housing, etc. by high-voltage leakage or corona discharge.)
- Never perform HID circuit inspection with a tester.
- Never touch the xenon bulb glass with hands. Never put oil and grease on it.
- Dispose of the used xenon bulb after packing it in thick vinyl without breaking it.
- Never wipe out dirt and contamination with organic solvent (thinner, gasoline, etc.).

FOR USA AND CANADA : Working with HFC-134a (R-134a)

INFOID:000000001848760

CAUTION:

- CFC-12 (R-12) refrigerant and HFC-134a (R-134a) refrigerant are not compatible. Compressor malfunction is likely to occur if the refrigerants are mixed, refer to "CONTAMINATED REFRIGERANT" below. To determine the purity of HFC-134a (R-134a) in the vehicle and recovery tank, use Refrigerant Recovery/Recycling Recharging equipment and Refrigerant Identifier.
- Use only specified lubricant for the HFC-134a (R-134a) A/C system and HFC-134a (R-134a) components. Compressor malfunction is likely to occur if lubricant other than that specified is used.
- The specified HFC-134a (R-134a) lubricant rapidly absorbs moisture from the atmosphere. The following handling precautions must be observed:
 - Cap (seal) immediately the component to minimize the entry of moisture from the atmosphere when removing refrigerant components from a vehicle.
 - Never remove the caps (unseal) until just before connecting the components when installing refrigerant components to a vehicle. Connect all refrigerant loop components as quickly as possible to minimize the entry of moisture into system.
 - Use only the specified lubricant from a sealed container. Reseal immediately containers of lubricant. Lubricant becomes moisture saturated and should not be used without proper sealing.
 - Never allow lubricant (Nissan A/C System Oil Type S) to come in contact with styrene foam parts. Damage may result.

CONTAMINATED REFRIGERANT

Take appropriate steps shown below if a refrigerant other than pure HFC-134a (R-134a) is identified in a vehicle:

- Explain to the customer that environmental regulations prohibit the release of contaminated refrigerant into the atmosphere.

PRECAUTIONS

< PRECAUTION >

- Explain that recovery of the contaminated refrigerant could damage service equipment and refrigerant supply.
- Suggest the customer return the vehicle to the location of previous service where the contamination may have occurred.
- In case of repairing, recover the refrigerant using only **dedicated equipment and containers. Never recover contaminated refrigerant into the existing service equipment.** Contact a local refrigerant product retailer for available service if the facility does not have dedicated recovery equipment. This refrigerant must be disposed of in accordance with all federal and local regulations. In addition, replacement of all refrigerant system components on the vehicle is recommended.
- The air conditioner warranty is void if the vehicle is within the warranty period. Please contact Nissan Customer Affairs for further assistance.

FOR USA AND CANADA : General Refrigerant Precaution

INFOID:000000001722432

WARNING:

- **Never breath A/C refrigerant and lubricant vapor or mist. Exposure may irritate eyes, nose and throat. Use only approved recovery/recycling equipment to discharge HFC-134a (R-134a) refrigerant. Ventilate work area before resuming service if accidental system discharge occurs. Additional health and safety information may be obtained from refrigerant and lubricant manufacturers.**
- **Never release refrigerant into the air. Use approved recovery/recycling equipment to capture the refrigerant each time an air conditioning system is discharged.**
- **Wear always eye and hand protection (goggles and gloves) when working with any refrigerant or air conditioning system.**
- **Never store or heat refrigerant containers above 52°C (126°F).**
- **Never heat a refrigerant container with an open flame; Place the bottom of the container in a warm pail of water if container warming is required.**
- **Never intentionally drop, puncture, or incinerate refrigerant containers.**
- **Keep refrigerant away from open flames: poisonous gas is produced if refrigerant burns.**
- **Refrigerant displaces oxygen, therefore be certain to work in well ventilated areas to prevent suffocation.**
- **Never pressure test or leakage test HFC-134a (R-134a) service equipment and/or vehicle air conditioning systems with compressed air during repair. Some mixtures of air and HFC-134a (R-134a) have been shown to be combustible at elevated pressures. These mixtures, if ignited, may cause injury or property damage. Additional health and safety information may be obtained from refrigerant manufacturers.**

FOR USA AND CANADA : Refrigerant Connection

INFOID:000000001722433

A new type refrigerant connection has been introduced to all refrigerant lines except the following location.

- Expansion valve to evaporator
- Refrigerant pressure sensor to liquid tank

O-RING AND REFRIGERANT CONNECTION

PRECAUTIONS

< PRECAUTION >

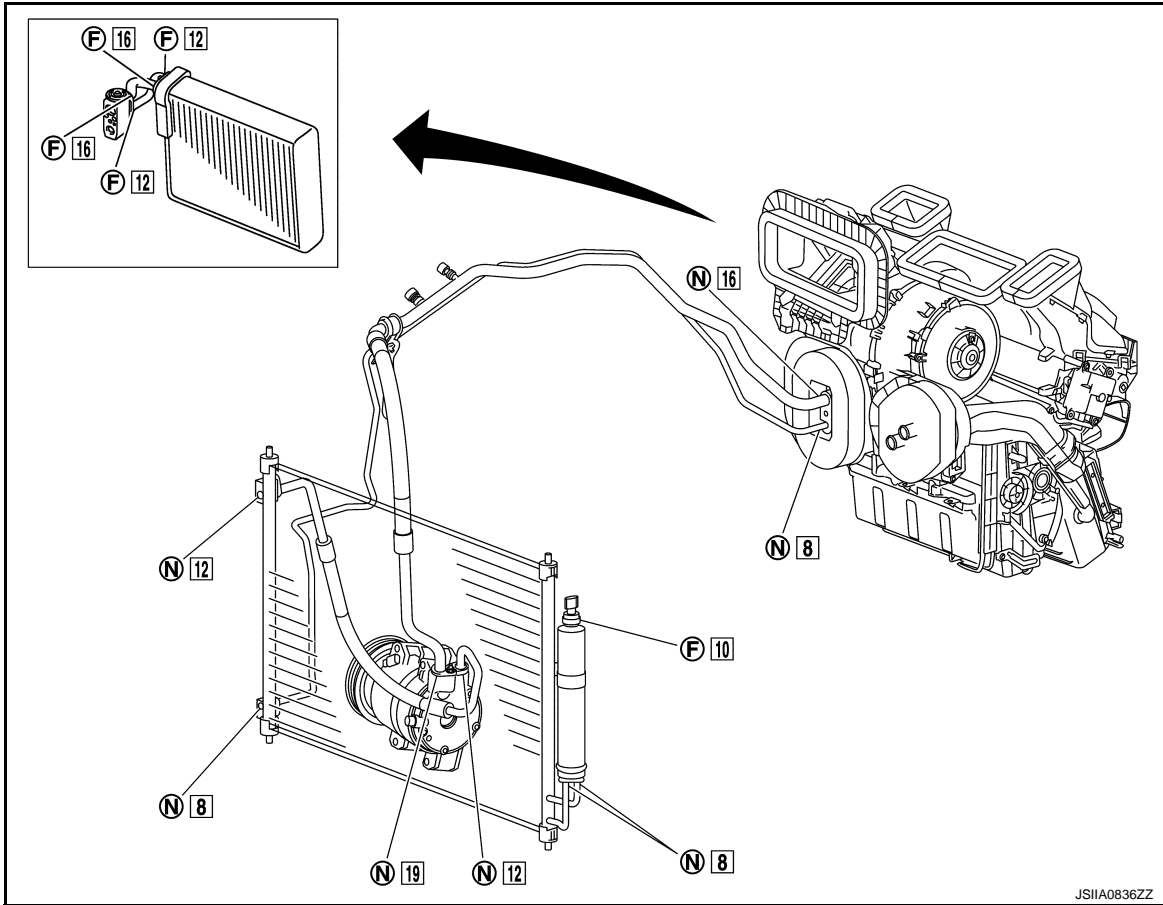

F. Former type refrigerant connection N. New type refrigerant connection

□: O-ring size

CAUTION:

The new and former refrigerant connections use different O-ring configurations. Never confuse O-rings since they are not interchangeable. Refrigerant may leak at the connection if a wrong O-ring is installed.

O-Ring Part Numbers and Specifications

Connection type	Piping connection point		Part number	QTY	O-ring size
New	Low-pressure flexible hose to expansion valve		92473 N8210	1	16
	Compressor to low-pressure flexible hose		92474 N8210	1	19
	Compressor to high-pressure flexible hose		92472 N8210	1	12
	Condenser to high-pressure flexible hose		92472 N8210	1	12
	Condenser to high-pressure pipe		92471 N8210	1	8
	High-pressure pipe to expansion valve		92471 N8210	1	8
	Liquid tank to condenser		92471 N8210	Inlet	1
		Outlet		1	
Former	Refrigerant pressure sensor to liquid tank		J2476 89956	1	10
	Evaporator pipe assembly	High-pressure side	92475 71L00	1	12
		Low-pressure side	92475 72L00	1	16

WARNING:

Check that all refrigerant is discharged into the recycling equipment and the pressure in the system is less than atmospheric pressure. Then gradually loosen the discharge side hose fitting and remove it.

PRECAUTIONS

< PRECAUTION >

CAUTION:

Observe the following when replacing or cleaning refrigerant cycle components.

- Store it in the same way as it is when mounted on the car when the compressor is removed. Failure to do so causes lubricant to enter the low-pressure chamber.
- Use always a torque wrench and a back-up wrench when connecting tubes.
- Plug immediately all openings to prevent entry of dust and moisture after disconnecting tubes.
- Connect the pipes at the final stage of the operation when installing an air conditioner in the vehicle. Never remove the seal caps of pipes and other components until just before required for connection.
- Allow components stored in cool areas to warm to working area temperature before removing seal caps. This prevents condensation from forming inside A/C components.
- Remove thoroughly moisture from the refrigeration system before charging the refrigerant.
- Replace always used O-rings.
- Apply lubricant to circle of the O-rings shown in illustration when connecting tube. Be careful not to apply lubricant to threaded portion.

Name : Nissan A/C System Oil Type S

- O-ring must be closely attached to the groove portion of tube.
- Be careful not to damage O-ring and tube when replacing the O-ring.
- Connect tube until a click can be heard. Then tighten the nut or bolt by hand. Check that the O-ring is installed to tube correctly.
- Perform leakage test and make sure that there is no leakage from connections after connecting line. Disconnect that line and replace the O-ring when the refrigerant leaking point is found. Then tighten connections of seal seat to the specified torque.

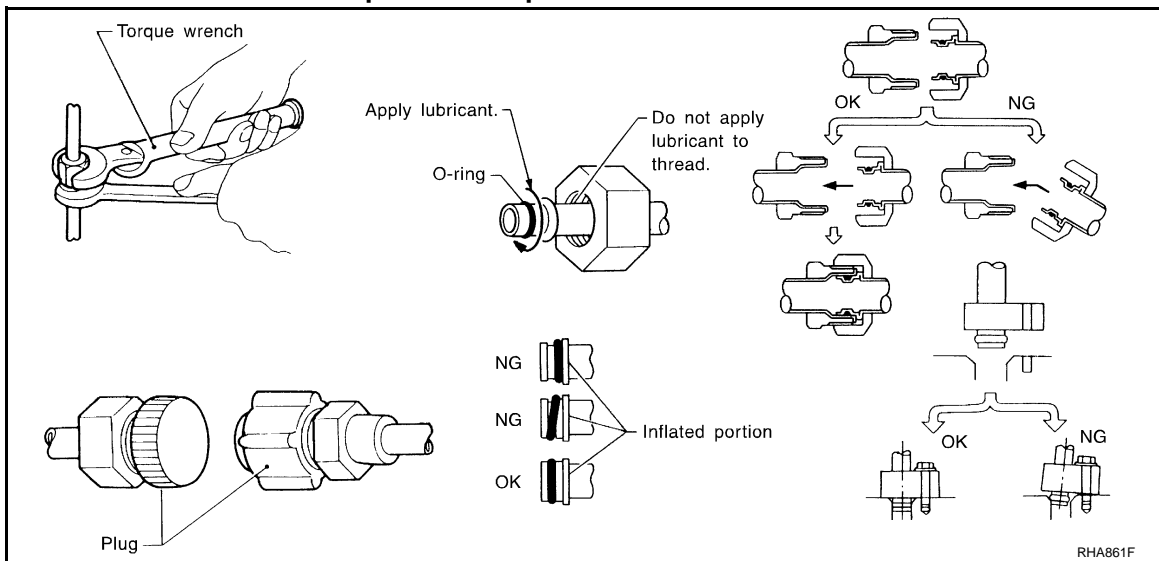

FOR USA AND CANADA : Service Equipment

INFOID:000000001722434

RECOVERY/RECYCLING EQUIPMENT

Be certain to follow the manufacturer's instructions for machine operation and machine maintenance. Never introduce any refrigerant other than that specified into the machine.

ELECTRICAL LEAK DETECTOR

Be certain to follow the manufacturer's instructions for tester operation and tester maintenance.

VACUUM PUMP

PRECAUTIONS

< PRECAUTION >

The lubricant contained inside the vacuum pump is not compatible with the specified lubricant for HFC-134a (R-134a) A/C systems. The vent side of the vacuum pump is exposed to atmospheric pressure. So the vacuum pump lubricant may migrate out of the pump into the service hose. This is possible when the pump is switched OFF after evacuation (vacuuming) and hose is connected to it. To prevent this migration, use a manual valve placed near the hose-to-pump connection, as per the following.

- Vacuum pumps usually have a manual isolator valve as part of the pump. Close this valve to isolate the service hose from the pump.
- Use a hose equipped with a manual shut-off valve near the pump end for pumps without an isolator. Close the valve to isolate the hose from the pump.
- Disconnect the hose from the pump if the hose has an automatic shut-off valve. As long as the hose is connected, the valve is open and lubricating oil may migrate.

Some one-way valves open when vacuum is applied and close under no vacuum condition. Such valves may restrict the pump's ability to pull a deep vacuum and are not recommended.

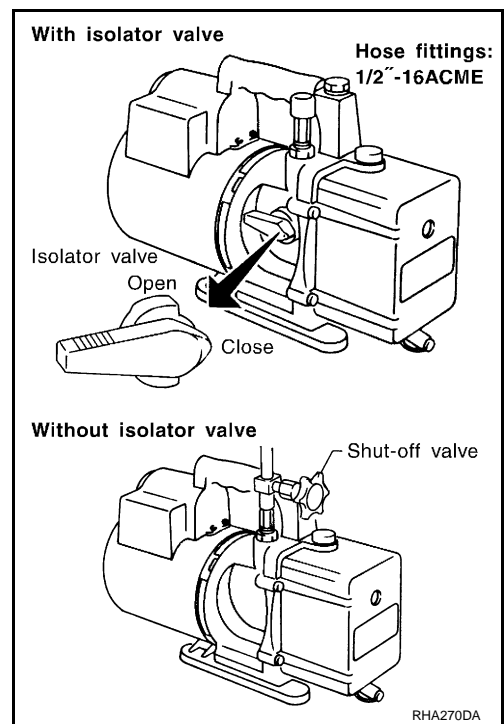

MANIFOLD GAUGE SET

Be certain that the gauge face indicates HFC-134a or R-134a. Be sure the gauge set has 1/2\"-16 ACME threaded connections for service hoses. Confirm the set has been used only with refrigerant HFC-134a (R-134a) and specified lubricants.

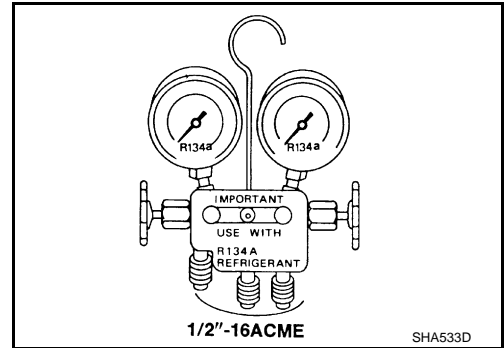

SERVICE HOSES

Be certain that the service hoses display the markings described (colored hose with black stripe). All hoses must equip positive shut-off devices (either manual or automatic) near the end of the hoses opposite to the manifold gauge.

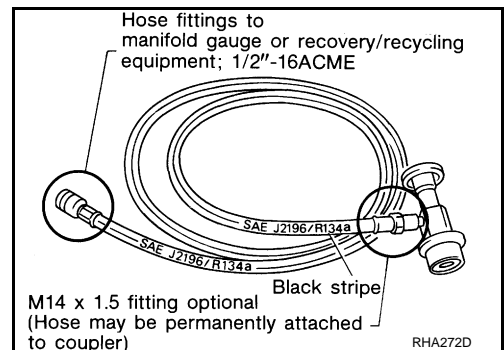

SERVICE COUPLERS

PRECAUTIONS

< PRECAUTION >

Never attempt to connect HFC-134a (R-134a) service couplers to a CFC-12 (R-12) A/C system. The HFC-134a (R-134a) couplers do not properly connect to the CFC-12 (R-12) system. However, if an improper connection is attempted, discharging and contamination may occur.

Shut-off valve rotation	A/C service valve
Clockwise	Open
Counterclockwise	Close

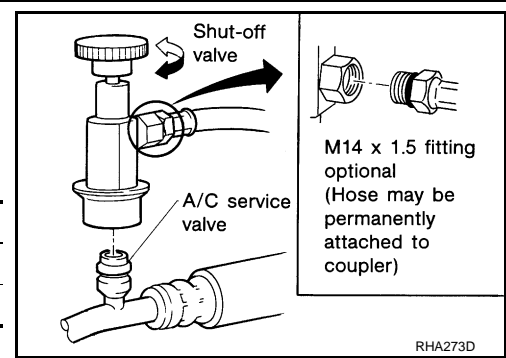

REFRIGERANT WEIGHT SCALE

Verify that no refrigerant other than HFC-134a (R-134a) and specified lubricants have been used with the scale. The hose fitting must be 1/2"-16 ACME if the scale controls refrigerant flow electronically.

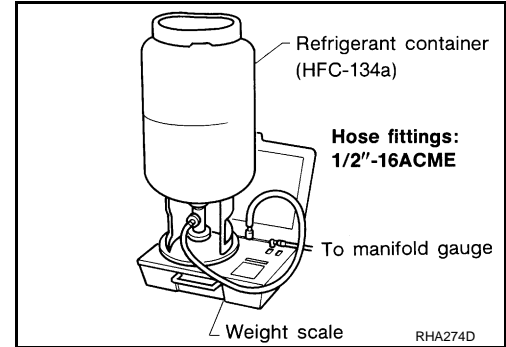

CHARGING CYLINDER

Using a charging cylinder is not recommended. Refrigerant may be vented into air from cylinder's top valve when filling the cylinder with refrigerant. Also, the accuracy of the cylinder is generally less than that of an electronic scale or of quality recycle/recharge equipment.

FOR MEXICO

FOR MEXICO : Precaution for Supplemental Restraint System (SRS) "AIR BAG" and "SEAT BELT PRE-TENSIONER"

INFOID:000000003248337

The Supplemental Restraint System such as "AIR BAG" and "SEAT BELT PRE-TENSIONER", used along with a front seat belt, helps to reduce the risk or severity of injury to the driver and front passenger for certain types of collision. Information necessary to service the system safely is included in the "SRS AIRBAG" and "SEAT BELT" of this Service Manual.

WARNING:

- To avoid rendering the SRS inoperative, which could increase the risk of personal injury or death in the event of a collision which would result in air bag inflation, all maintenance must be performed by an authorized NISSAN/INFINITI dealer.
- Improper maintenance, including incorrect removal and installation of the SRS, can lead to personal injury caused by unintentional activation of the system. For removal of Spiral Cable and Air Bag Module, see the "SRS AIRBAG".
- Do not use electrical test equipment on any circuit related to the SRS unless instructed to in this Service Manual. SRS wiring harnesses can be identified by yellow and/or orange harnesses or harness connectors.

FOR MEXICO : Precaution Necessary for Steering Wheel Rotation After Battery Disconnect

INFOID:000000003248344

NOTE:

- This Procedure is applied only to models with Intelligent Key system and NVIS/IVIS (NISSAN/INFINITI VEHICLE IMMOBILIZER SYSTEM - NATS).
- Remove and install all control units after disconnecting both battery cables with the ignition knob in the "LOCK" position.
- Always use CONSULT-III to perform self-diagnosis as a part of each function inspection after finishing work. If DTC is detected, perform trouble diagnosis according to self-diagnostic results.

PRECAUTIONS

< PRECAUTION >

For models equipped with the Intelligent Key system and NVIS/IVIS, an electrically controlled steering lock mechanism is adopted on the key cylinder.

For this reason, if the battery is disconnected or if the battery is discharged, the steering wheel will lock and steering wheel rotation will become impossible.

If steering wheel rotation is required when battery power is interrupted, follow the procedure below before starting the repair operation.

OPERATION PROCEDURE

1. Connect both battery cables.

NOTE:

Supply power using jumper cables if battery is discharged.

2. Use the Intelligent Key or mechanical key to turn the ignition switch to the "ACC" position. At this time, the steering lock will be released.
3. Disconnect both battery cables. The steering lock will remain released and the steering wheel can be rotated.
4. Perform the necessary repair operation.
5. When the repair work is completed, return the ignition switch to the "LOCK" position before connecting the battery cables. (At this time, the steering lock mechanism will engage.)
6. Perform a self-diagnosis check of all control units using CONSULT-III.

FOR MEXICO : Precaution for Procedure without Cowl Top Cover

INFOID:000000003248352

When performing the procedure after removing cowl top cover, cover the lower end of windshield with urethane, etc.

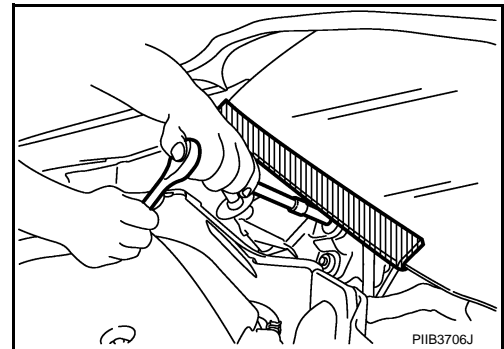

FOR MEXICO : Precautions For Xenon Headlamp Service

INFOID:000000003248359

WARNING:

Comply with the following warnings to prevent any serious accident.

- Disconnect the battery cable (negative terminal) or the power supply fuse before installing, removing, or touching the xenon headlamp (bulb included). The xenon headlamp contains high-voltage generated parts.
- Never work with wet hands.
- Check the xenon headlamp ON-OFF status after assembling it to the vehicle. Never turn the xenon headlamp ON in other conditions. Connect the power supply to the vehicle-side connector. (Turning it ON outside the lamp case may cause fire or visual impairments.)
- Never touch the bulb glass immediately after turning it OFF. It is extremely hot.

CAUTION:

Comply with the following cautions to prevent any error and malfunction.

- Install the xenon bulb securely. (Insufficient bulb socket installation may melt the bulb, the connector, the housing, etc. by high-voltage leakage or corona discharge.)
- Never perform HID circuit inspection with a tester.
- Never touch the xenon bulb glass with hands. Never put oil and grease on it.
- Dispose of the used xenon bulb after packing it in thick vinyl without breaking it.
- Never wipe out dirt and contamination with organic solvent (thinner, gasoline, etc.).

FOR MEXICO : Working with HFC-134a (R-134a)

INFOID:000000003248364

CAUTION:

- CFC-12 (R-12) refrigerant and HFC-134a (R-134a) refrigerant are not compatible. Compressor malfunction is likely to occur if the refrigerants are mixed, refer to "CONTAMINATED REFRIGERANT"

PRECAUTIONS

< PRECAUTION >

- below. To determine the purity of HFC-134a (R-134a) in the vehicle and recovery tank, use Refrigerant Recovery/Recycling Recharging equipment and Refrigerant Identifier.
- Use only specified lubricant for the HFC-134a (R-134a) A/C system and HFC-134a (R-134a) components. Compressor malfunction is likely to occur if lubricant other than that specified is used.
 - The specified HFC-134a (R-134a) lubricant rapidly absorbs moisture from the atmosphere. The following handling precautions must be observed:
 - Cap (seal) immediately the component to minimize the entry of moisture from the atmosphere when removing refrigerant components from a vehicle.
 - Never remove the caps (unseal) until just before connecting the components when installing refrigerant components to a vehicle. Connect all refrigerant loop components as quickly as possible to minimize the entry of moisture into system.
 - Use only the specified lubricant from a sealed container. Reseal immediately containers of lubricant. Lubricant becomes moisture saturated and should not be used without proper sealing.
 - Never allow lubricant (Nissan A/C System Oil Type S) to come in contact with styrene foam parts. Damage may result.

CONTAMINATED REFRIGERANT

Take appropriate steps shown below if a refrigerant other than pure HFC-134a (R-134a) is identified in a vehicle:

- Explain to the customer that environmental regulations prohibit the release of contaminated refrigerant into the atmosphere.
- Explain that recovery of the contaminated refrigerant could damage service equipment and refrigerant supply.
- Suggest the customer return the vehicle to the location of previous service where the contamination may have occurred.
- In case of repairing, recover the refrigerant using only **dedicated equipment and containers. Never recover contaminated refrigerant into the existing service equipment.** Contact a local refrigerant product retailer for available service if the facility does not have dedicated recovery equipment. This refrigerant must be disposed of in accordance with all federal and local regulations. In addition, replacement of all refrigerant system components on the vehicle is recommended.
- The air conditioner warranty is void if the vehicle is within the warranty period. Please contact Nissan Customer Affairs for further assistance.

FOR MEXICO : General Refrigerant Precaution

INFOID:000000003248365

WARNING:

- **Never breath A/C refrigerant and lubricant vapor or mist. Exposure may irritate eyes, nose and throat. Use only approved recovery/recycling equipment to discharge HFC-134a (R-134a) refrigerant. Ventilate work area before resuming service if accidental system discharge occurs. Additional health and safety information may be obtained from refrigerant and lubricant manufacturers.**
- **Never release refrigerant into the air. Use approved recovery/recycling equipment to capture the refrigerant each time an air conditioning system is discharged.**
- **Wear always eye and hand protection (goggles and gloves) when working with any refrigerant or air conditioning system.**
- **Never store or heat refrigerant containers above 52°C (126°F).**
- **Never heat a refrigerant container with an open flame; Place the bottom of the container in a warm pail of water if container warming is required.**
- **Never intentionally drop, puncture, or incinerate refrigerant containers.**
- **Keep refrigerant away from open flames: poisonous gas is produced if refrigerant burns.**
- **Refrigerant displaces oxygen, therefore be certain to work in well ventilated areas to prevent suffocation.**
- **Never pressure test or leakage test HFC-134a (R-134a) service equipment and/or vehicle air conditioning systems with compressed air during repair. Some mixtures of air and HFC-134a (R-134a) have been shown to be combustible at elevated pressures. These mixtures, if ignited, may cause injury or property damage. Additional health and safety information may be obtained from refrigerant manufacturers.**

FOR MEXICO : Refrigerant Connection

INFOID:000000003248367

A new type refrigerant connection has been introduced to all refrigerant lines except the following location.

- Expansion valve to evaporator
- Refrigerant pressure sensor to liquid tank

PRECAUTIONS

< PRECAUTION >

O-RING AND REFRIGERANT CONNECTION

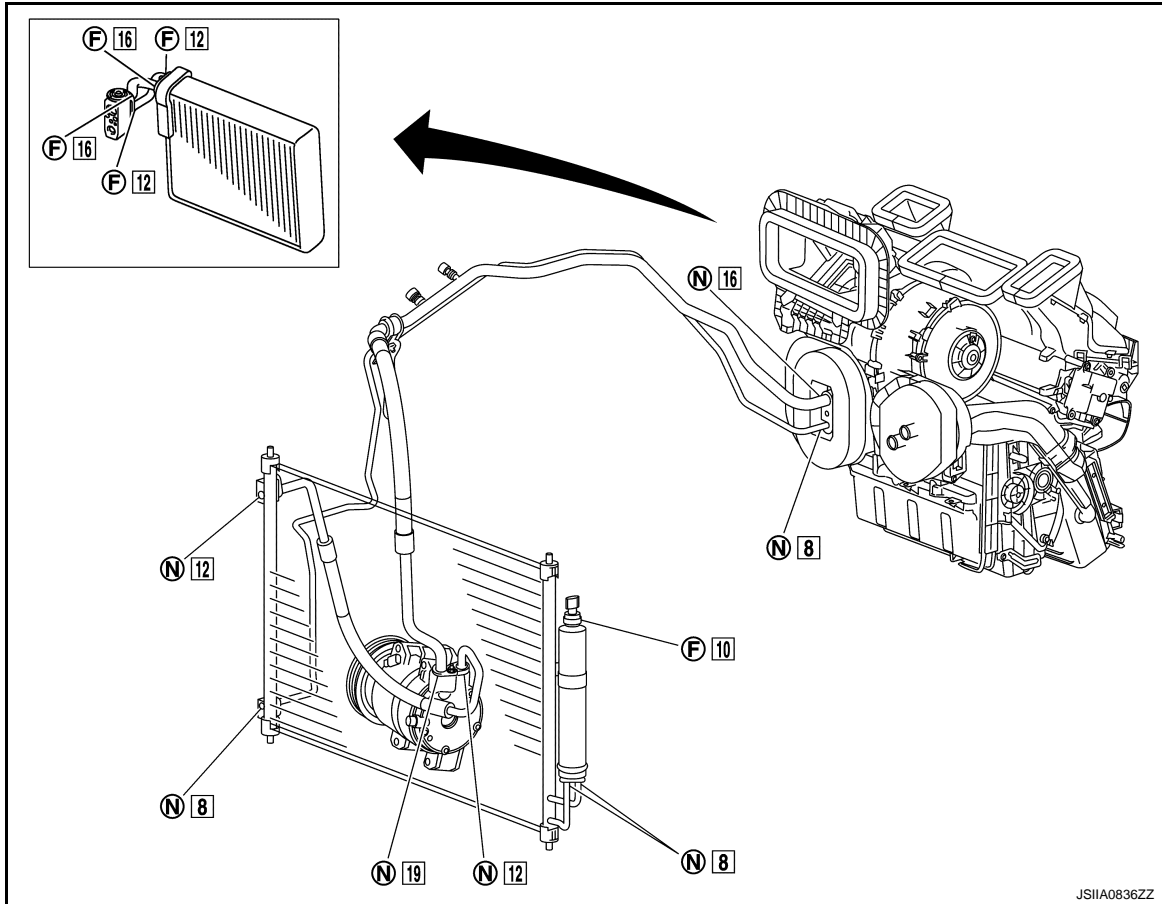

F. Former type refrigerant connection N. New type refrigerant connection

□: O-ring size

CAUTION:

The new and former refrigerant connections use different O-ring configurations. Never confuse O-rings since they are not interchangeable. Refrigerant may leak at the connection if a wrong O-ring is installed.

O-Ring Part Numbers and Specifications

Connection type	Piping connection point		Part number	QTY	O-ring size	
New	Low-pressure flexible hose to expansion valve		92473 N8210	1	16	
	Compressor to low-pressure flexible hose		92474 N8210	1	19	
	Compressor to high-pressure flexible hose		92472 N8210	1	12	
	Condenser to high-pressure flexible hose		92472 N8210	1	12	
	Condenser to high-pressure pipe		92471 N8210	1	8	
	High-pressure pipe to expansion valve		92471 N8210	1	8	
	Liquid tank to condenser		Inlet	92471 N8210	1	8
Outlet			1			
Former	Refrigerant pressure sensor to liquid tank		J2476 89956	1	10	
	Evaporator pipe assembly		High-pressure side	92475 71L00	1	12
			Low-pressure side	92475 72L00	1	16

WARNING:

PRECAUTIONS

< PRECAUTION >

Check that all refrigerant is discharged into the recycling equipment and the pressure in the system is less than atmospheric pressure. Then gradually loosen the discharge side hose fitting and remove it.

CAUTION:

Observe the following when replacing or cleaning refrigerant cycle components.

- Store it in the same way as it is when mounted on the car when the compressor is removed. Failure to do so causes lubricant to enter the low-pressure chamber.
- Use always a torque wrench and a back-up wrench when connecting tubes.
- Plug immediately all openings to prevent entry of dust and moisture after disconnecting tubes.
- Connect the pipes at the final stage of the operation when installing an air conditioner in the vehicle. Never remove the seal caps of pipes and other components until just before required for connection.
- Allow components stored in cool areas to warm to working area temperature before removing seal caps. This prevents condensation from forming inside A/C components.
- Remove thoroughly moisture from the refrigeration system before charging the refrigerant.
- Replace always used O-rings.
- Apply lubricant to circle of the O-rings shown in illustration when connecting tube. Be careful not to apply lubricant to threaded portion.

Name : Nissan A/C System Oil Type S

- O-ring must be closely attached to the groove portion of tube.
- Be careful not to damage O-ring and tube when replacing the O-ring.
- Connect tube until a click can be heard. Then tighten the nut or bolt by hand. Check that the O-ring is installed to tube correctly.
- Perform leakage test and make sure that there is no leakage from connections after connecting line. Disconnect that line and replace the O-ring when the refrigerant leaking point is found. Then tighten connections of seal seat to the specified torque.

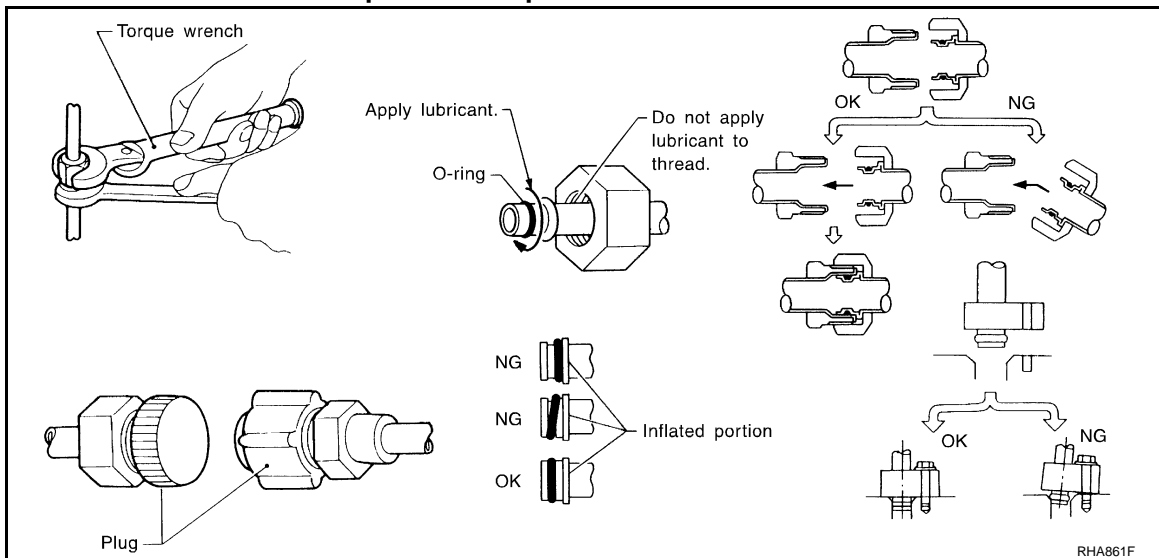

FOR MEXICO : Service Equipment

INFOID:000000003248368

RECOVERY/RECYCLING EQUIPMENT

Be certain to follow the manufacturer's instructions for machine operation and machine maintenance. Never introduce any refrigerant other than that specified into the machine.

ELECTRICAL LEAK DETECTOR

Be certain to follow the manufacturer's instructions for tester operation and tester maintenance.

VACUUM PUMP

PRECAUTIONS

< PRECAUTION >

The lubricant contained inside the vacuum pump is not compatible with the specified lubricant for HFC-134a (R-134a) A/C systems. The vent side of the vacuum pump is exposed to atmospheric pressure. So the vacuum pump lubricant may migrate out of the pump into the service hose. This is possible when the pump is switched OFF after evacuation (vacuuming) and hose is connected to it. To prevent this migration, use a manual valve placed near the hose-to-pump connection, as per the following.

- Vacuum pumps usually have a manual isolator valve as part of the pump. Close this valve to isolate the service hose from the pump.
- Use a hose equipped with a manual shut-off valve near the pump end for pumps without an isolator. Close the valve to isolate the hose from the pump.
- Disconnect the hose from the pump if the hose has an automatic shut-off valve. As long as the hose is connected, the valve is open and lubricating oil may migrate.

Some one-way valves open when vacuum is applied and close under no vacuum condition. Such valves may restrict the pump's ability to pull a deep vacuum and are not recommended.

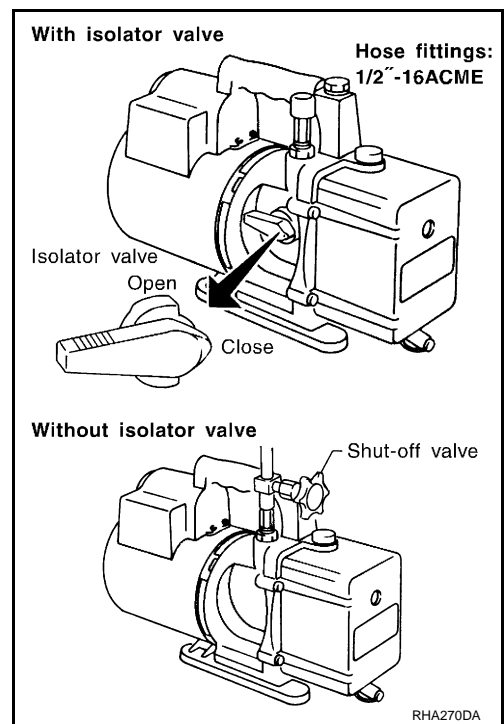

MANIFOLD GAUGE SET

Be certain that the gauge face indicates HFC-134a or R-134a. Be sure the gauge set has 1/2\"-16 ACME threaded connections for service hoses. Confirm the set has been used only with refrigerant HFC-134a (R-134a) and specified lubricants.

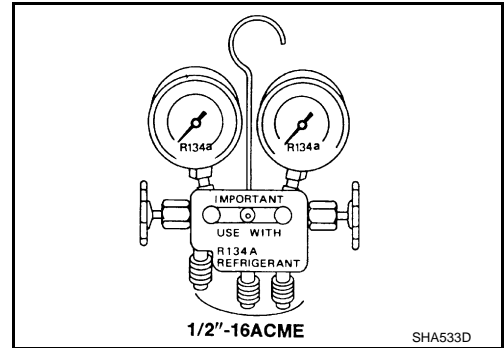

SERVICE HOSES

Be certain that the service hoses display the markings described (colored hose with black stripe). All hoses must equip positive shut-off devices (either manual or automatic) near the end of the hoses opposite to the manifold gauge.

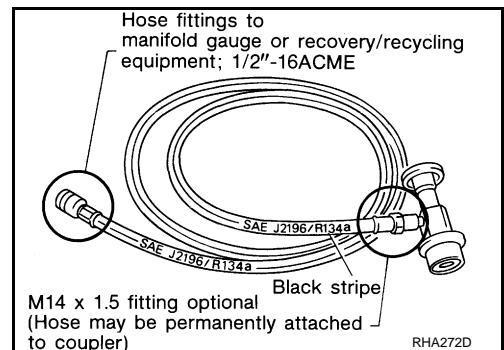

SERVICE COUPLERS

PRECAUTIONS

< PRECAUTION >

Never attempt to connect HFC-134a (R-134a) service couplers to a CFC-12 (R-12) A/C system. The HFC-134a (R-134a) couplers do not properly connect to the CFC-12 (R-12) system. However, if an improper connection is attempted, discharging and contamination may occur.

Shut-off valve rotation	A/C service valve
Clockwise	Open
Counterclockwise	Close

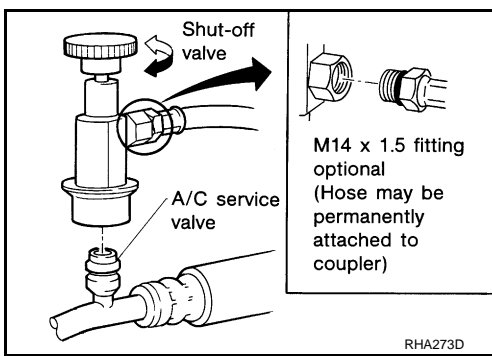

REFRIGERANT WEIGHT SCALE

Verify that no refrigerant other than HFC-134a (R-134a) and specified lubricants have been used with the scale. The hose fitting must be 1/2"-16 ACME if the scale controls refrigerant flow electronically.

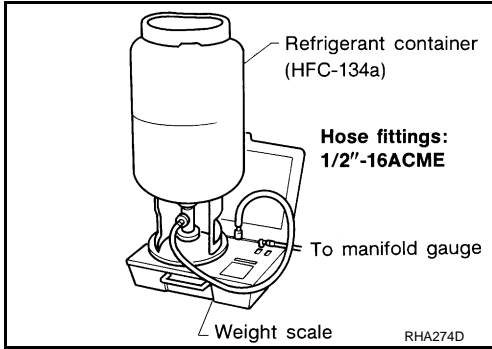

CHARGING CYLINDER

Using a charging cylinder is not recommended. Refrigerant may be vented into air from cylinder's top valve when filling the cylinder with refrigerant. Also, the accuracy of the cylinder is generally less than that of an electronic scale or of quality recycle/recharge equipment.

A
B
C
D
E
F
G
H
J
K
L
M
N
O
P

HA

COMPRESSOR

< PRECAUTION >

COMPRESSOR

General Precautions

INFOID:000000001722435

CAUTION:

- Plug all openings to prevent moisture and foreign matter from entering.
- Store it in the same way as it is when mounted on the car when the compressor is removed.
- Follow “LUBRICANT ADJUSTING PROCEDURE FOR COMPRESSOR REPLACEMENT” exactly when replacing or repairing compressor. Refer to [HA-30, "Maintenance of Lubricant Quantity"](#).
- Keep friction surfaces between clutch and pulley clean. Wipe it off by using a clean waste cloth moistened with thinner if the surface is contaminated with lubricant.
- Turn the compressor shaft by hand more than five turns in both directions after compressor service operation. This distributes equally lubricant inside the compressor. Let the engine idle and operate the compressor for one hour after the compressor is installed.
- Apply voltage to the new one and check for normal operation after replacing the compressor magnet clutch.

FLUORESCENT LEAK DETECTOR

< PRECAUTION >

FLUORESCENT LEAK DETECTOR

General Precautions

INFOID:000000001722436

CAUTION:

- The A/C system contains a fluorescent leak detection dye used for locating refrigerant leakages. An ultraviolet (UV) lamp is required to illuminate the dye when inspecting for leakages.
- Wear always fluorescence enhancing UV safety goggles to protect eyes and enhance the visibility of the fluorescent dye.
- The fluorescent dye leak detector is not a replacement for an electrical leak detector (SST: J-41995). The fluorescent dye leak detector should be used in conjunction with an electrical leak detector (SST: J-41995) to pin-point refrigerant leakages.
- Read and follow all manufacture's operating instructions and precautions prior to performing the work for the purpose of safety and customer's satisfaction.
- A compressor shaft seal should not necessarily be repaired because of dye seepage. The compressor shaft seal should only be repaired after confirming the leakage with an electrical leak detector (SST: J-41995).
- Remove always any remaining dye from the leakage area after repairs are completed to avoid a misdiagnosis during a future service.
- Never allow dye to come into contact with painted body panels or interior components. Clean immediately with the approved dye cleaner if dye is spilled. Fluorescent dye left on a surface for an extended period of time cannot be removed.
- Never spray the fluorescent dye cleaning agent on hot surfaces (engine exhaust manifold, etc.).
- Never use more than one refrigerant dye bottle (1/4 ounce /7.4 cc) per A/C system.
- Leak detection dyes for HFC-134a (R-134a) and CFC-12 (R-12) A/C systems are different. Never use HFC-134a (R-134a) leak detection dye in CFC-12 (R-12) A/C system, or CFC-12 (R-12) leak detection dye in HFC-134a (R-134a) A/C system, or A/C system damage may result.
- The fluorescent properties of the dye remains for three years or a little over unless a compressor malfunction occurs.

IDENTIFICATION

NOTE:

Vehicles with factory installed fluorescent dye have a green label.
Vehicles without factory installed fluorescent dye have a blue label.

IDENTIFICATION LABEL FOR VEHICLE

Vehicles with factory installed fluorescent dye have the identification label on the front side of hood.

A

B

C

D

E

F

G

H

HA

J

K

L

M

N

O

P

PREPARATION

< PREPARATION >

PREPARATION

PREPARATION

Special Service Tool

INFOID:000000001825151

The actual shapes of Kent-Moore tools may differ from those of special service tools illustrated here.



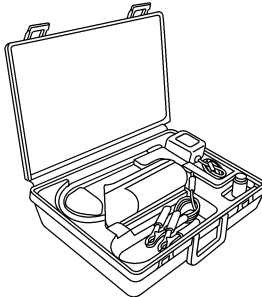
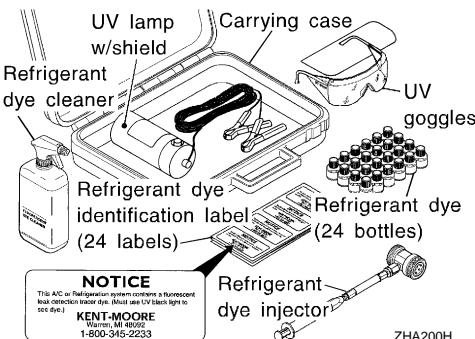

HFC-134a (R-134a) Service Tool and Equipment

- Never mix HFC-134a (R-134a) refrigerant and/or its specified lubricant with CFC-12 (R-12) refrigerant and/or its lubricant.
- Separate and non-interchangeable service equipment must be used for handling each type of refrigerant/lubricant.
- Refrigerant container fittings, service hose fittings and service equipment fittings (equipment which handles refrigerant and/or lubricant) are different between CFC-12 (R-12) and HFC-134a (R-134a). This is to avoid mixed use of the refrigerants/lubricant.
- Never use adapters that convert one size fitting to another: refrigerant/lubricant contamination occurs and compressor malfunction may result.

Tool number (Kent-Moore No.) Tool name	Description
<p>(ACR2005-NI) ACR5 A/C Service Center</p>  <p style="text-align: right; font-size: small;">WJIA0293E</p>	<p>Function: Refrigerant recovery, recycling and recharging</p>
<p>(J-41995) Electrical leak detector</p>  <p style="text-align: right; font-size: small;">AHA281A</p>	<p>Power supply: DC 12 V (Battery terminal)</p>
<p>(J-43926) Refrigerant dye leak detection kit</p> <p>Kit includes:</p> <ul style="list-style-type: none"> (J-42220) UV lamp and UV safety goggles (J-41459) HFC-134a (R-134a) dye injector Use with J-41447, 1/4 ounce bottle (J-41447) HFC-134a (R-134a) fluorescent leak detection dye (Box of 24, 1/4 ounce bottles) (J-43872) Refrigerant dye cleaner  <p style="text-align: right; font-size: small;">ZHA200H</p>	<p>Power supply: DC 12 V (Battery terminal)</p>

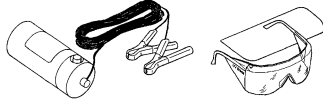
PREPARATION

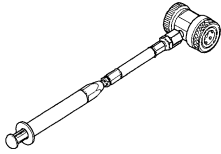
< PREPARATION >

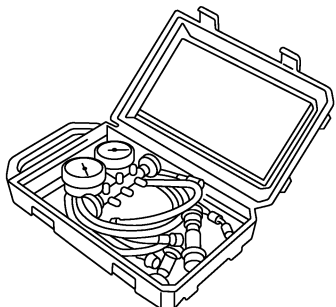
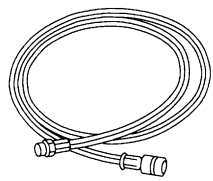
Tool number (Kent-Moore No.) Tool name	Description	A
(J-42220) UV lamp and UV safety goggles  SHA438F	Power supply: DC 12 V (Battery terminal) For checking refrigerant leakage when fluorescent dye is equipped in A/C system Includes: UV lamp and UV safety goggles	B C
(J-41447) HFC-134a (R-134a) fluorescent leak detection dye (Box of 24, 1/4 ounce bottles)  Refrigerant dye (24 bottles) SHA439F	Application: For HFC-134a (R-134a) PAG oil Container: 1/4 ounce (7.4 cc) bottle (Includes self-adhesive dye identification labels for affixing to vehicle after charging system with dye.)	D E F
(J-41459) HFC-134a (R-134a) dye injector Use with J-41447, 1/4 ounce bottle  SHA440F	For injecting 1/4 ounce of fluorescent leak detection dye into A/C system	G H
(J-43872) Refrigerant dye cleaner  SHA441F	For cleaning dye spills	HA J
(J-39183) Manifold gauge set (with hoses and couplers)  RJIA0196E	Identification: <ul style="list-style-type: none"> The gauge face indicates HFC-134a (R-134a). Fitting size: Thread size <ul style="list-style-type: none"> 1/2"-16 ACME 	K L M
Service hoses <ul style="list-style-type: none"> High-pressure side hose (J-39501-72) Low-pressure side hose (J-39502-72) Utility hose (J-39476-72)  S-NT201	Hose color: <ul style="list-style-type: none"> Low-pressure side hose: Blue with black stripe High-pressure side hose: Red with black stripe Utility hose: Yellow with black stripe or green with black stripe Hose fitting to gauge: <ul style="list-style-type: none"> 1/2"-16 ACME 	N O P

PREPARATION

< PREPARATION >

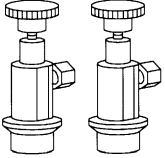
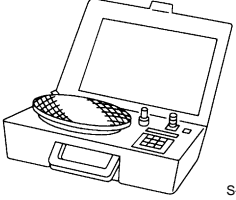
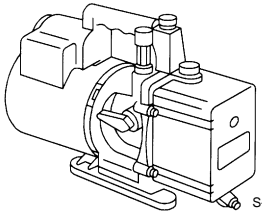
Tool number (Kent-Moore No.) Tool name	Description
<p>Service couplers</p> <ul style="list-style-type: none"> • High-pressure side coupler (J-39500-20) • Low-pressure side coupler (J-39500-24)  <p style="text-align: right; font-size: small;">S-NT202</p>	<p>Hose fitting to service hose: M14 x 1.5 fitting is optional or permanently attached.</p>
<p>(J-39650) Refrigerant weight scale</p>  <p style="text-align: right; font-size: small;">S-NT200</p>	<p>For measuring of refrigerant Fitting size: Thread size 1/2"-16 ACME</p>
<p>(J-39649) Vacuum pump (Including the isolator valve)</p>  <p style="text-align: right; font-size: small;">S-NT203</p>	<p>Capacity:</p> <ul style="list-style-type: none"> • Air displacement: 4 CFM • Micron rating: 20 microns • Oil capacity: 482 g (17 oz.) <p>Fitting size: Thread size</p> <ul style="list-style-type: none"> • 1/2"-16 ACME

Commercial Service Tool

INFOID:000000001825152

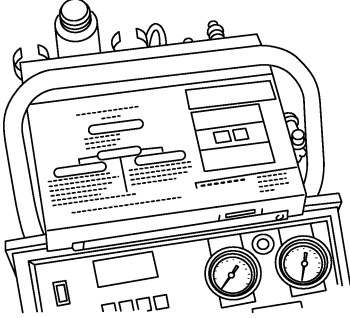
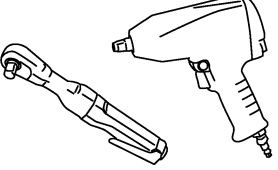
Tool name	Description
<p>Refrigerant identifier equipment</p>  <p style="text-align: right; font-size: x-small;">RJIA0197E</p>	<p>Checking for refrigerant purity and system contamination</p>
<p>Power tool</p>  <p style="text-align: right; font-size: x-small;">PBIC0190E</p>	<p>For loosening bolts and nuts</p>

Sealant or/and Lubricant

INFOID:000000001825153



HFC-134a (R-134a) Service Tool and Equipment

- Never mix HFC-134a (R-134a) refrigerant and/or its specified lubricant with CFC-12 (R-12) refrigerant and/or its lubricant.
- Separate and non-interchangeable service equipment must be used for handling each type of refrigerant/lubricant.

PREPARATION

< PREPARATION >

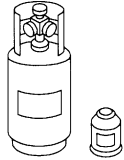
- Refrigerant container fittings, service hose fittings and service equipment fittings (equipment which handles refrigerant and/or lubricant) are different between CFC-12 (R-12) and HFC-134a (R-134a). This is to avoid mixed use of the refrigerants/lubricant.
- Never use adapters that convert one size fitting to another: refrigerant/lubricant contamination occurs and compressor malfunction may result.

Tool name	Description
<p>HFC-134a (R-134a) refrigerant</p> <div style="text-align: center;">  <p style="font-size: small;">S-NT196</p> </div>	<p>Container color: Light blue Container marking: HFC-134a (R-134a) Fitting size: Thread size</p> <ul style="list-style-type: none"> • Large container 1/2"-16 ACME
<p>Nissan A/C System Oil Type S (DH-PS)</p> <div style="text-align: center;">  <p style="font-size: small;">S-NT197</p> </div>	<p>Type: Polyalkylene glycol oil (PAG), type S (DH-PS) Application: HFC-134a (R-134a) swash plate compressors (Nissan only) Capacity: 40 m ℓ (1.4 US fl oz., 1.4 Imp fl oz.)</p>

A
B
C
D
E
F
G
H
J
K
L
M
N
O
P

HA

LUBRICANT

< ON-VEHICLE MAINTENANCE >

ON-VEHICLE MAINTENANCE

LUBRICANT

Maintenance of Lubricant Quantity

INFOID:000000001722439

The lubricant in the compressor circulates through the system the refrigerant. Add lubricant to compressor when replacing any component or after a large refrigerant leakage occurred. It is important to maintain the specified amount.

If lubricant quantity is not maintained properly, the following malfunctions may result:

- Lack of lubricant: May lead to a seized compressor.
- Excessive lubricant: Inadequate cooling (thermal exchange interference)

LUBRICANT

Name : NISSAM A/C System Oil Type S

LUBRICANT RETURN OPERATION

Adjust the lubricant quantity according to the test group shown below.

1. CHECK LUBRICANT RETURN OPERATION

Can lubricant return operation be performed?

- A/C system works normally.
- There is no evidence of a large amount of lubricant leakage.

CAUTION:

Never perform the lubricant return operation if excessive lubricant leakage is noted.

Is it successful?

YES >> GO TO 2.

NO >> GO TO 3.

2. PERFORM LUBRICANT RETURN OPERATION, PROCEEDING AS PER THE FOLLOWING

1. Start the engine, and set to the following conditions:
 - Engine speed: Idling to 1,200 rpm
 - A/C switch: ON
 - Blower speed: Max. position
 - Temp. control: Optional [Set so that intake air temperature is 25 to 30°C (77 to 86°F).]
 - Intake position: Recirculation (REC)
2. Perform lubricant return operation for approximately 10 minutes.
3. Stop the engine.

>> GO TO 3.

3. CHECK REPLACEMENT PART

Should the compressor be replaced?

YES >> Refer to [HA-31, "Lubricant Adjusting Procedure for Compressor Replacement"](#).

NO >> Refer to [HA-30, "Lubricant Adjusting Procedure for Components Replacement Except Compressor"](#).

Lubricant Adjusting Procedure for Components Replacement Except Compressor

INFOID:000000001871831

Add the correct amount of lubricant to the system after replacing any of the following major components.
Amount of lubricant to be added:

LUBRICANT

< ON-VEHICLE MAINTENANCE >

Part replaced	Lubricant to be added to system	Remarks
	Amount of lubricant m ℓ (US fl oz., Imp fl oz.)	
Evaporator	75 (2.5, 2.6)	—
Condenser	35 (1.2, 1.2)	—
Liquid tank	10 (0.3, 0.4)	—
In case of refrigerant leakage	30 (1.0, 1.1)	Large leakage
	—	Small leakage *1

*1: No addition of lubricant is needed if the refrigerant leakage is small.

Lubricant Adjusting Procedure for Compressor Replacement

INFOID:000000001871832

1. Check recovery/recycling recharging equipment gauges before connecting recovery/recycling recharging equipment to vehicle. No refrigerant pressure should be displayed. Recover refrigerant from equipment lines if NG.
2. Connect recovery/recycling recharging equipment to vehicle. Confirm refrigerant purity in supply tank using recovery/recycling recharging equipment and refrigerant identifier. Refer to [HA-12. "FOR USA AND CANADA : Working with HFC-134a \(R-134a\)"](#) (FOR USA AND CANADA) or [HA-18. "FOR MEXICO : Working with HFC-134a \(R-134a\)"](#) (FOR MEXICO) if NG.
3. Confirm refrigerant purity in vehicle A/C system using recovery/recycling recharging equipment and refrigerant identifier. If NG, refer to [HA-12. "FOR USA AND CANADA : Working with HFC-134a \(R-134a\)"](#) (FOR USA AND CANADA) or [HA-18. "FOR MEXICO : Working with HFC-134a \(R-134a\)"](#) (FOR MEXICO).
4. Discharge refrigerant into the refrigerant recovery/recycling equipment. Measure lubricant discharged into the recovery/recycling equipment.
5. Drain the lubricant from the old (removed) compressor into a graduated container and recover the amount of lubricant drained.
6. Drain the lubricant from the new compressor into a separate. Then clean container.
7. Measure an amount of new lubricant installed equal to amount drained from old compressor. Add this lubricant to new compressor through the suction port opening.
8. Measure an amount of new lubricant equal to the amount recovered during discharging. Add this lubricant to new compressor through the suction port opening.
9. Add another 5 m ℓ (0.2 US fl oz., 0.2 Imp fl oz.) of lubricant at this time if the liquid tank also needs to be replaced.

LUBRICANT

< ON-VEHICLE MAINTENANCE >

Do not add this 5 mℓ (0.2 US fl oz., 0.2 Imp fl oz.) of lubricant when replacing the compressor only.

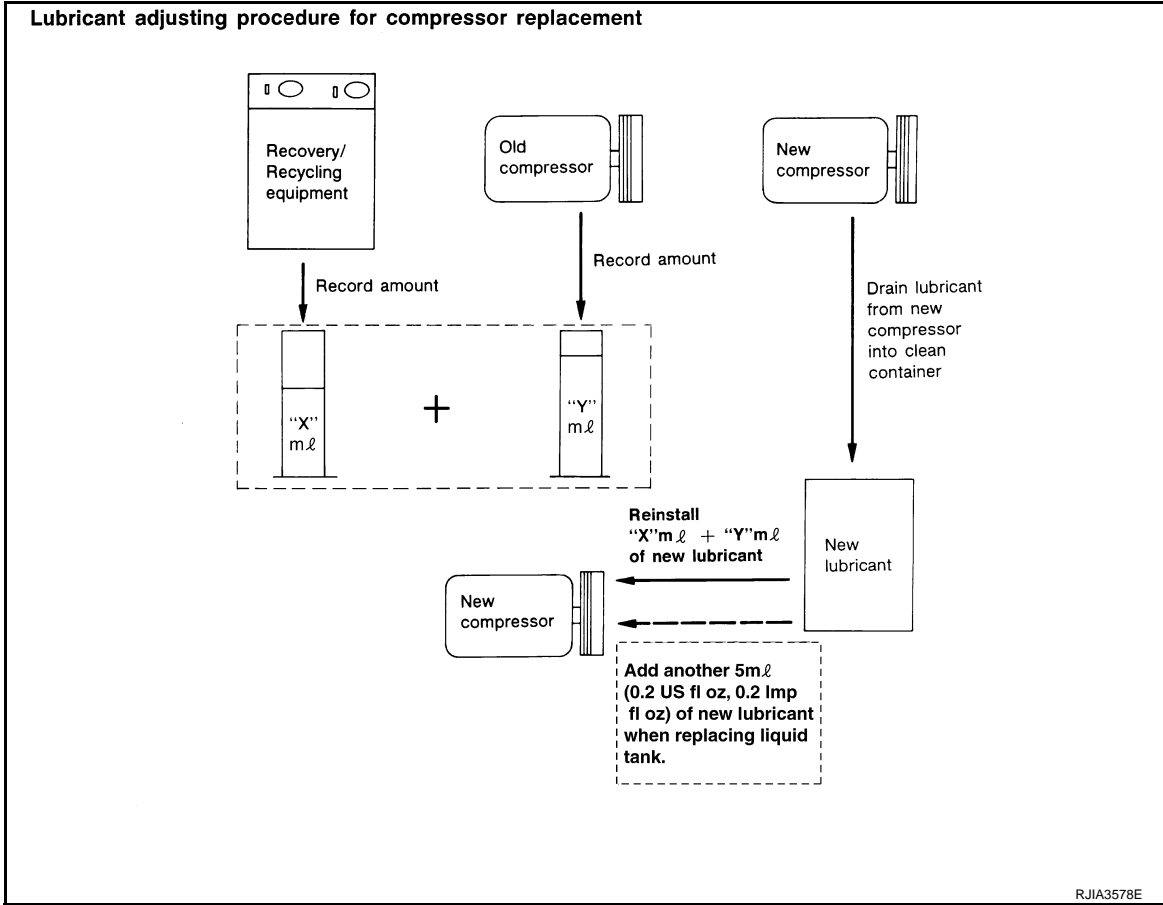

REFRIGERATION SYSTEM

< ON-VEHICLE MAINTENANCE >

REFRIGERATION SYSTEM

Inspection

INFOID:000000001722440

1. CHECK BLOWER MOTOR OPERATION

Check blower motor operation. Refer to [HAC-28, "Component Function Check"](#).

Is the inspection result normal?

YES >> GO TO 2.

NO >> Repair or replace the parts according to the inspection results.

2. CHECK COMPRESSOR OPERATION

Check compressor operation. Refer to [HAC-32, "Component Function Check"](#).

Is the inspection result normal?

YES >> GO TO 3.

NO >> Repair or replace the parts according to the inspection results.

3. CHECK REFRIGERANT CYCLE PRESSURE

Connect refrigerant recovery/recycling recharging equipment to the vehicle and perform the diagnosis with the gauge pressure. Refer to [HA-7, "Trouble Diagnosis For Unusual Pressure"](#).

Is the inspection result normal?

YES >> Perform the performance test. Refer to [HA-33, "Performance Chart"](#).



NO >> Repair or replace the parts according to the inspection results.

Performance Chart

INFOID:000000001722441

TEST CONDITION

Testing must be performed as per the following:

Vehicle condition	Indoors or in the shade (in a well-ventilated place)
Doors	Closed
Door windows	Open
Hood	Open
TEMP.	Max. COLD
Mode switch	 (Ventilation) set
Intake switch	 (Recirculation) set
 Fan (blower) speed	Max. speed set
Engine speed	Idle speed

Operate the air conditioning system for 10 minutes before taking measurements.

TEST READING

Recirculating-to-discharge Air Temperature Table

Inside air (Recirculating air) at A/C unit assembly inlet		Discharge air temperature at center ventilator °C (°F)
Relative humidity %	Air temperature °C (°F)	
50 - 60	25 (77)	8.8 - 11.2 (48 - 52)
	30 (86)	12.9 - 15.9 (55 - 61)
	35 (95)	17.0 - 20.4 (63 - 69)
60 - 70	25 (77)	11.2 - 13.8 (52 - 57)
	30 (86)	15.9 - 18.9 (61 - 66)
	35 (95)	20.4 - 24.0 (69 - 75)

REFRIGERATION SYSTEM

< ON-VEHICLE MAINTENANCE >

Ambient Air Temperature-to-operating Pressure Table

Ambient air		High-pressure (Discharge side) kPa (bar, kg/cm ² , psi)	Low-pressure (Suction side) kPa (bar, kg/cm ² , psi)
Relative humidity %	Air temperature °C (°F)		
50 - 70	25 (77)	900 - 1,105 (9.00 - 11.05, 9.18 - 11.3, 130.5 - 160.2)	175 - 220 (1.75 - 2.20, 1.8 - 2.2, 25.4 - 31.9)
	30 (86)	1,100 - 1,345 (11.00 - 13.45, 11.2 - 13.7, 159.5 - 195.0)	220 - 270 (2.20 - 2.70, 2.2 - 2.8, 31.9 - 39.2)
	35 (95)	1,310 - 1,605 (13.10 - 16.05, 13.4 - 16.4, 190.0 - 232.7)	270 - 325 (2.70 - 3.25, 2.8 - 3.3, 39.2 - 47.1)
	40 (104)	1,480 - 1,810 (14.80 - 18.10, 15.1 - 18.5, 214.6 - 262.5)	315 - 375 (3.15 - 3.75, 3.2 - 3.8, 45.7 - 54.4)

Refrigerant Leakages

INFOID:000000001722442

Perform a visual inspection of all refrigeration parts, fittings, hoses and components for signs of A/C lubricant leakage, damage and corrosion. A/C lubricant leakage may indicate an area of refrigerant leakage. Allow extra inspection time in these areas when using either an electrical leak detector or fluorescent dye leak detector (SST: J-42220).

Confirm the leakage with an electrical leak detector if dye is observed. It is possible a prior leakage was repaired and not properly cleaned.

Do not stop when one leakage is found but continue checking for additional leakages at all system components and connections when searching for leakages.

Move the probe along the suspected leakage area at 1 to 2 inches per second and no further than 1/4 inch from the component when searching for refrigerant leakages using an electrical leak detector.

CAUTION:

Moving the electrical leak detector probe slower and closer to the suspected leakage area improves the chances of finding a leakage.

FLUORESCENT LEAK DETECTOR

< ON-VEHICLE MAINTENANCE >

FLUORESCENT LEAK DETECTOR

Inspection

INFOID:000000001722446

CHECKING SYSTEM FOR LEAKAGES USING THE FLUORESCENT LEAK DETECTOR

1. Check A/C system for leakages using the UV lamp and safety goggles (SST: J-42220) in a low sunlight area (area without windows preferable). Illuminate all components, fittings and lines. The dye appears as a bright green/yellow area at the point of leakage. Fluorescent dye observed at the evaporator drain opening indicates an evaporator core assembly (tubes, core or expansion valve) leakage.
2. Use an adjustable mirror or wipe the area with a clean shop rag or cloth, with the UV lamp for dye residue if the suspected area is difficult to see.
3. Remove any residual dye using dye cleaner (SST: J-43872) to prevent future misdiagnosis after the leakage is repaired.
4. Perform a system performance check and verify the leakage repair with an approved electrical leak detector.

NOTE:

Other gases in the work area or substances on the A/C components, for example, anti-freeze, windshield washer fluid, solvents and lubricants, may falsely trigger the leak detector. Make sure the surfaces to be checked are clean.

Clean with a dry cloth or blow off with shop air.

Do not allow the sensor tip of the detector to contact with any substance. This may also cause false readings and may damage the detector.

DYE INJECTION

(This procedure is only necessary when recharging the system or when the compressor has seized and was replaced.)

1. Check A/C system static (at rest) pressure. Pressure must be at least 345 kPa (3.45 bar, 3.52 kg/cm², 50 psi).
2. Pour one bottle (1/4 ounce / 7.4 cc) of the A/C refrigerant dye into the injector tool (SST: J-41459).
3. Connect the injector tool to the A/C low-pressure side service valve.
4. Start the engine. Then switch A/C ON.
5. Inject one bottle (1/4 ounce / 7.4 cc) of fluorescent dye through the low-pressure service valve using dye injector tool (SST: J-41459) (refer to the manufacture's operating instructions) when the A/C operating (compressor running).
6. Disconnect the injector tool from the service valve with the engine still running.

CAUTION:

Be careful when replacing the A/C system or a component, pour the dye directly into the open system connection and proceed with the service procedures.

7. Operate the A/C system for a minimum of 20 minutes to mix the dye with the system oil. Depending on the leakage size, operating conditions and location of the leakage, it may take from minutes to days for the dye to penetrate a leakage and become visible.
8. Attach a blue label if necessary.

ELECTRICAL LEAK DETECTOR

< ON-VEHICLE MAINTENANCE >

ELECTRICAL LEAK DETECTOR

Inspection

INFOID:000000001722447

PRECAUTIONS FOR HANDLING LEAK DETECTOR

Use an electrical leak detector (SST: J-41995) or equivalent when performing a refrigerant leakage check. Ensure that the instrument is calibrated and set properly per the operating instructions.

The leak detector is a delicate device. Read the operating instructions and perform any specified maintenance for using the leakage detector properly.

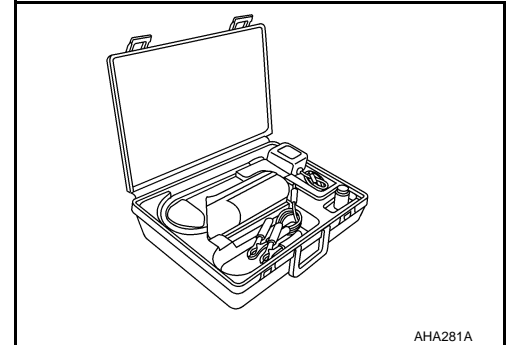

1. Position probe approximately 5 mm (3/16 in) away from point to be checked.

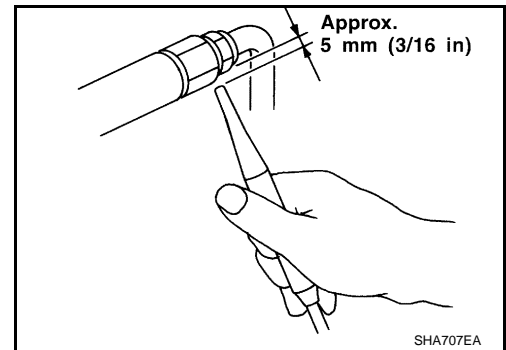

2. Circle each fitting completely with probe when testing.

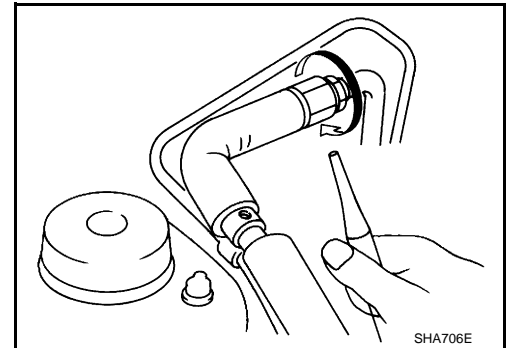

3. Move probe along component approximately 25 to 50 mm (1 to 2 in)/sec.

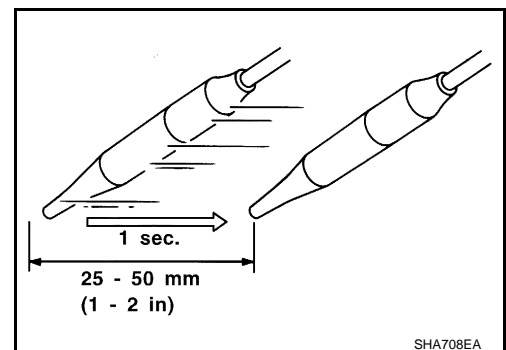

CHECKING PROCEDURE

Check that there is no refrigerant vapor, shop chemicals, or cigarette smoke in the vicinity of the vehicle to prevent inaccurate or false readings. Perform the leakage test in calm area (low air/wind movement) so that the leaking refrigerant is not dispersed.

1. Stop the engine.

ELECTRICAL LEAK DETECTOR

< ON-VEHICLE MAINTENANCE >

2. Connect a suitable A/C manifold gauge set (SST: J-39183) to the A/C service valves.
3. Check if the A/C refrigerant pressure is at least 345 kPa (3.45 bar, 3.52 kg/cm², 50 psi) above 16°C (61°F). Recover/evacuate and recharge the system with the specified amount of refrigerant if less than specification.

NOTE:

Leakages may not be detected since the system may not reach 345 kPa (3.45 bar, 3.52 kg/cm², 50 psi) at temperatures below 16°C (61°F).

4. Perform the leakage test from the high-pressure side (compressor discharge a to evaporator inlet h) to the low-pressure side (evaporator drain hose i to shaft seal m). Perform a leakage check for the following areas carefully. Clean the component to be checked and move the leakage detected probe completely around the connection/component.

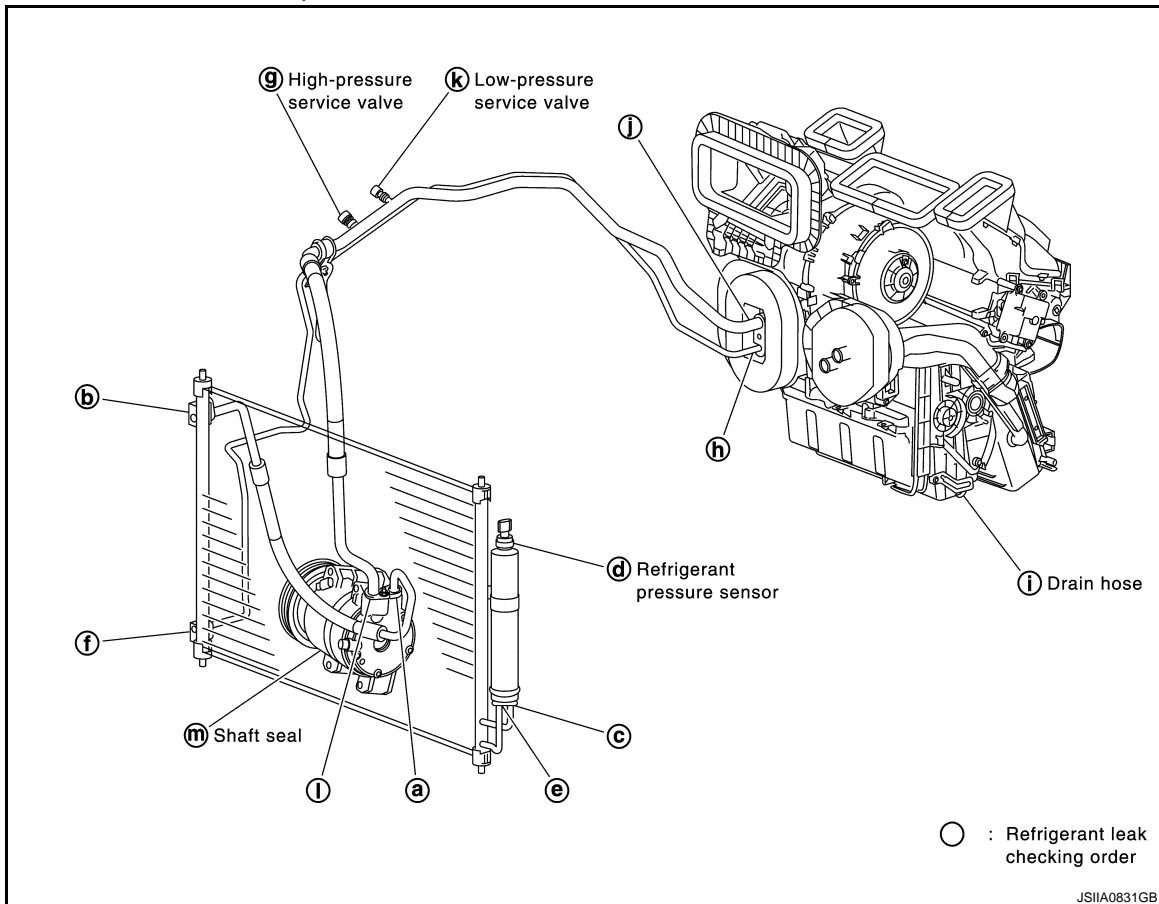

Compressor

Check the fitting of high- and low-pressure flexible hoses, relief valve and shaft seal.

Condenser

Check the fitting of high-pressure flexible hose and pipe.

Liquid tank

Check the fitting of condenser and refrigerant pressure sensor.

Service valves

Check all around the service valves. Ensure service valve caps are secured on the service valves (to prevent leakages).

NOTE:

Wipe any residue from valves to prevent any false readings by leak detector after removing A/C manifold gauge set from service valves.

Cooling unit (Evaporator)

Turn blower fan on "High" for at least 15 seconds to dissipate any refrigerant trace in the cooling unit with engine OFF. Wait a minimum of 10 minutes accumulation time (refer to the manufacturer's recommended procedure for actual wait time) before inserting the leak detector probe into the drain hose.

Keep the probe inserted for at least 10 seconds. Use caution not to contaminate the probe tip with water or dirt that may be in the drain hose.

ELECTRICAL LEAK DETECTOR

< ON-VEHICLE MAINTENANCE >

5. Verify at least once by blowing compressed air into area of suspected leakage, then repeat check as outlined above if a leak detector detects a leakage.
6. Do not stop when one leakage is found. Continue checking for additional leakages at all system components.
Perform steps 7 - 10 if no leakages is found.
7. Start the engine.
8. Set the A/C control as per the following;
 - a. A/C switch: ON
 - b. Air flow: VENT (Ventilation)
 - c. Intake door position: Recirculation (REC)
 - d. Temperature setting: Max. cold
 - e. Fan speed: High
9. Run engine at 1,500 rpm for at least 2 minutes.
10. Stop the engine and perform leakage check again following steps 4 through 6 above.
Refrigerant leakages should be checked immediately after stopping the engine. Begin with the leak detector at the compressor. The pressure on the high-pressure side drops gradually after refrigerant circulation stops and pressure on the low-pressure side rises gradually, as shown in the graph. Some leakages is more easily detected when pressure is high.

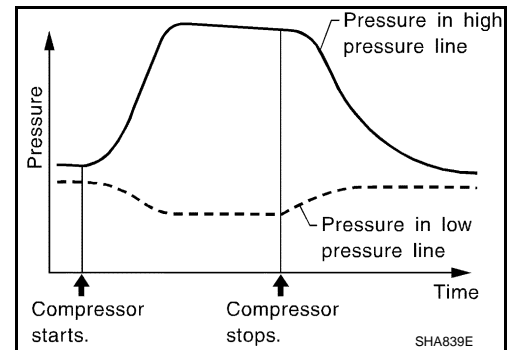

11. Check recovery/recycling recharging equipment gauges before connecting recovery/recycling recharging equipment to vehicle. No refrigerant pressure should be displayed. Recover refrigerant from equipment lines if pressure is displayed, and then check refrigerant purity.
12. Confirm refrigerant purity in supply tank using recovery/recycling recharging equipment and refrigerant identifier.
13. Confirm refrigerant purity in vehicle A/C system using recovery/recycling recharging equipment and refrigerant identifier.
14. Discharge A/C system using approved refrigerant recovery equipment. Repair the leaking fitting or component if necessary.
15. Evacuate and recharge A/C system and perform the leakage test to confirm no refrigerant leakages.
16. Perform A/C performance test to ensure system works normally.

REFRIGERATION SYSTEM

< ON-VEHICLE REPAIR >

ON-VEHICLE REPAIR

REFRIGERATION SYSTEM

Exploded View

INFOID:000000001722450

Refer to [HA-13, "FOR USA AND CANADA : Refrigerant Connection"](#) (FOR USA AND CANADA) or [HA-19, "FOR MEXICO : Refrigerant Connection"](#) (FOR MEXICO).

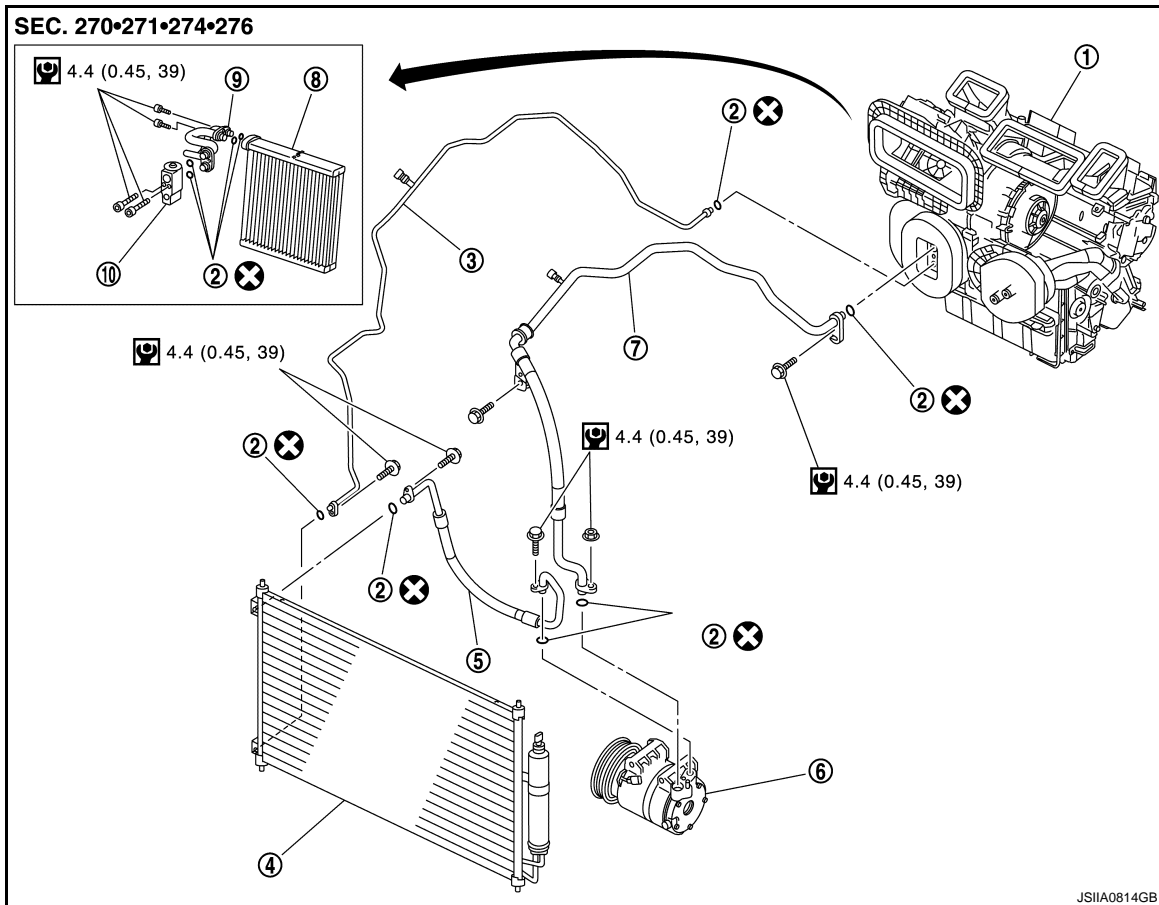

- | | | |
|-------------------------------|--------------------------------|-----------------------------|
| 1. A/C unit assembly | 2. O-ring | 3. High-pressure pipe |
| 4. Condenser | 5. High-pressure flexible hose | 6. Compressor |
| 7. Low-pressure flexible hose | 8. Evaporator | 9. Evaporator pipe assembly |
| 10. Expansion valve | | |

Refer to [GI-4, "Components"](#) for symbols in the figure.

Inspection After Installation

INFOID:000000001849301

SETTING OF SERVICE TOOLS AND EQUIPMENT

Discharging Refrigerant

WARNING:

Never breath A/C refrigerant and lubricant vapor or mist. Exposure may irritate eyes, nose and throat. Remove HFC-134a (R-134a) from A/C system using certified service equipment meeting requirements of SAE J-2210 [HFC-134a (R-134a) recycling equipment] or J-2209 [HFC-134a (R-134a) recovery equipment]. Ventilate work area before resuming service if accidental system discharge occurs. Additional health and safety information may be obtained from refrigerant and lubricant manufacturers.

REFRIGERATION SYSTEM

< ON-VEHICLE REPAIR >

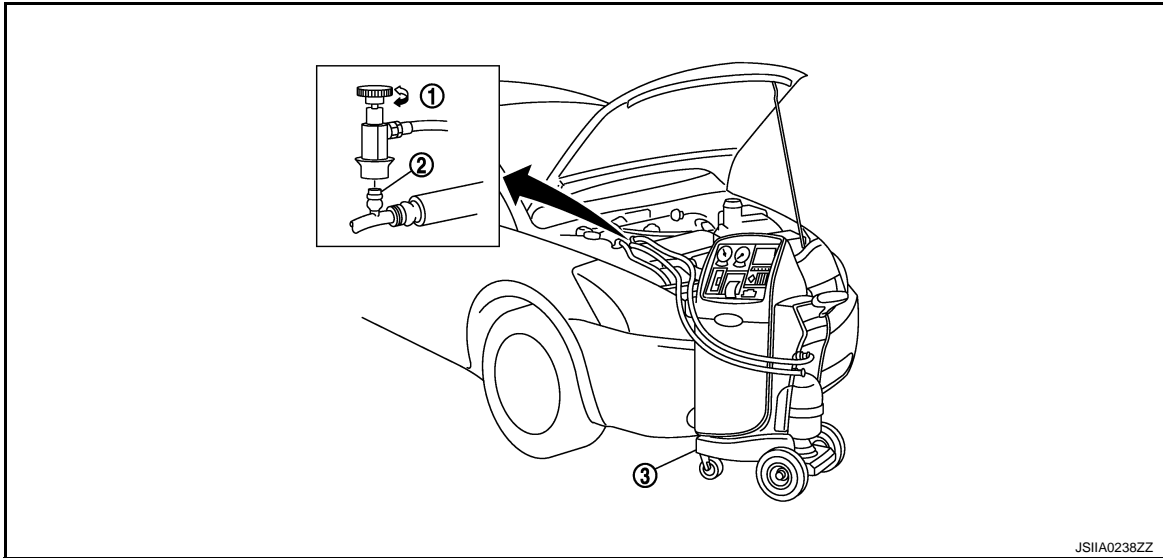

JSIIA0238ZZ

- 1. Shut-off valve
- 2. A/C service valve
- 3. Recovery/Recycling/Recharging equipment

Evacuating System and Charging Refrigerant

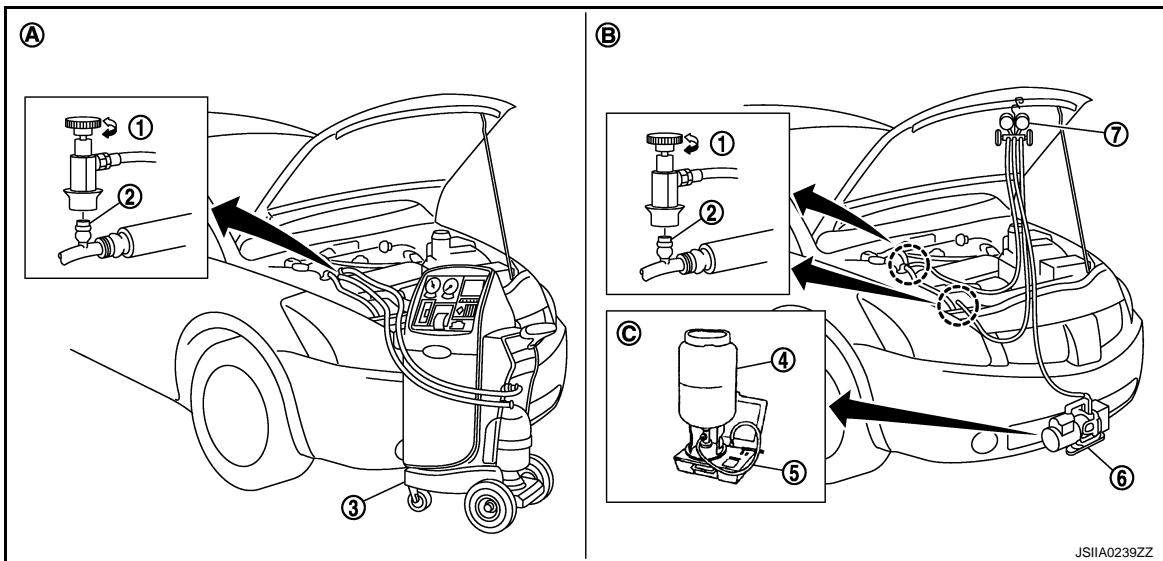

JSIIA0239ZZ

- 1. Shut-off valve
- 2. A/C service valve
- 3. Recovery/Recycling/Recharging equipment
- 4. Refrigerant container (HFC-134a)
- 5. Weight scale (J-39650)
- 6. Vacuum pump (J-39649)
- 7. Manifold gauge set (J-39183)
- A. Preferred (best) method
- B. Alternative method
- C. For charging

REFRIGERATION SYSTEM

< ON-VEHICLE REPAIR >

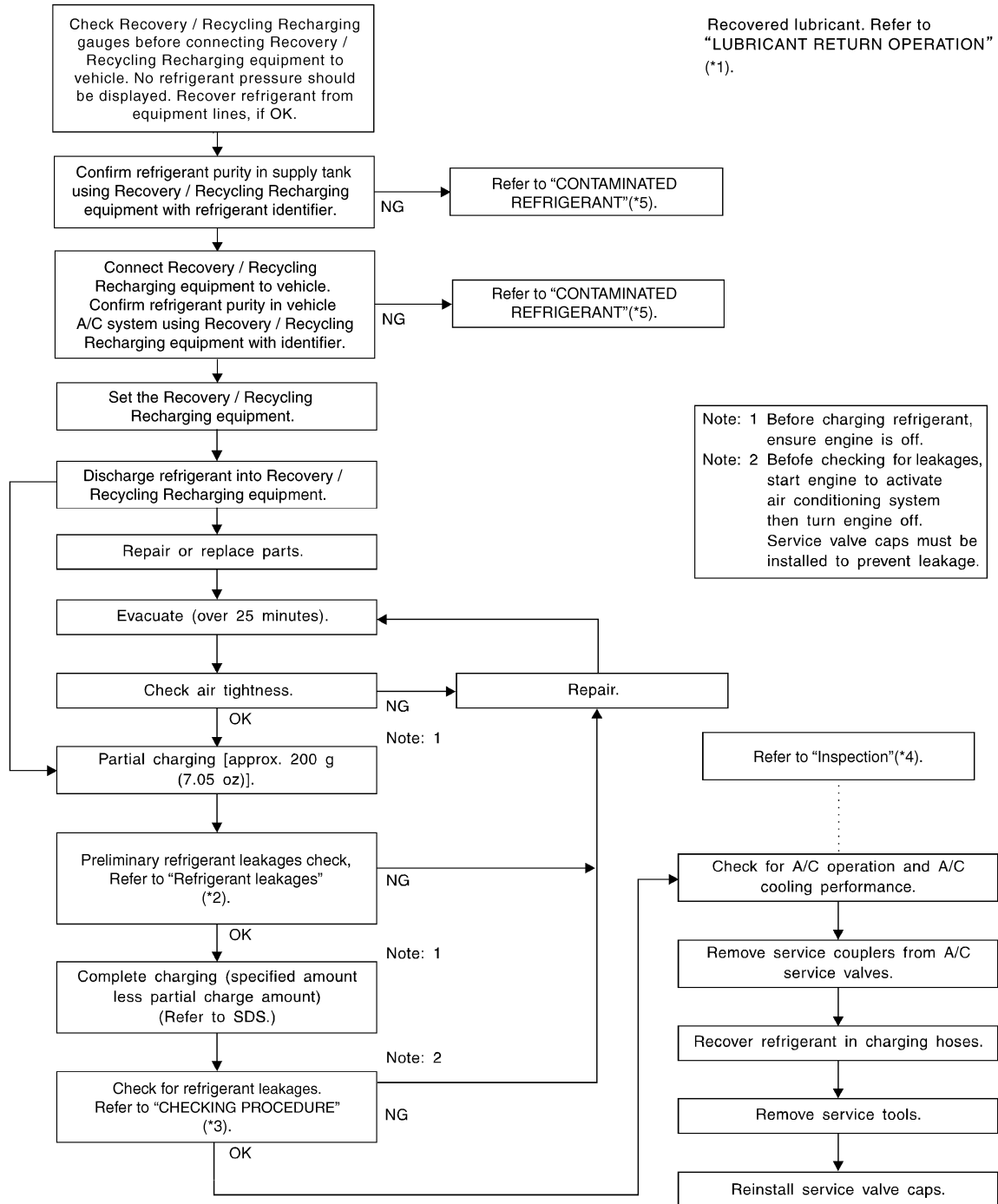

JSIIA0859GB

*1 [HA-30. "Maintenance of Lubricant Quantity".](#)

*4 [HA-33. "Inspection".](#)

*2 [HA-34. "Refrigerant Leakages".](#)

*5 [HA-12. "FOR USA AND CANADA : Working with HFC-134a \(R-134a\)" \(FOR USA AND CANADA\) or HA-18. "FOR MEXICO : Working with HFC-134a \(R-134a\)" \(FOR MEXICO\).](#)

*3 [HA-36. "Inspection".](#)

COMPRESSOR

< ON-VEHICLE REPAIR >

COMPRESSOR

Exploded View

INFOID:000000001722457

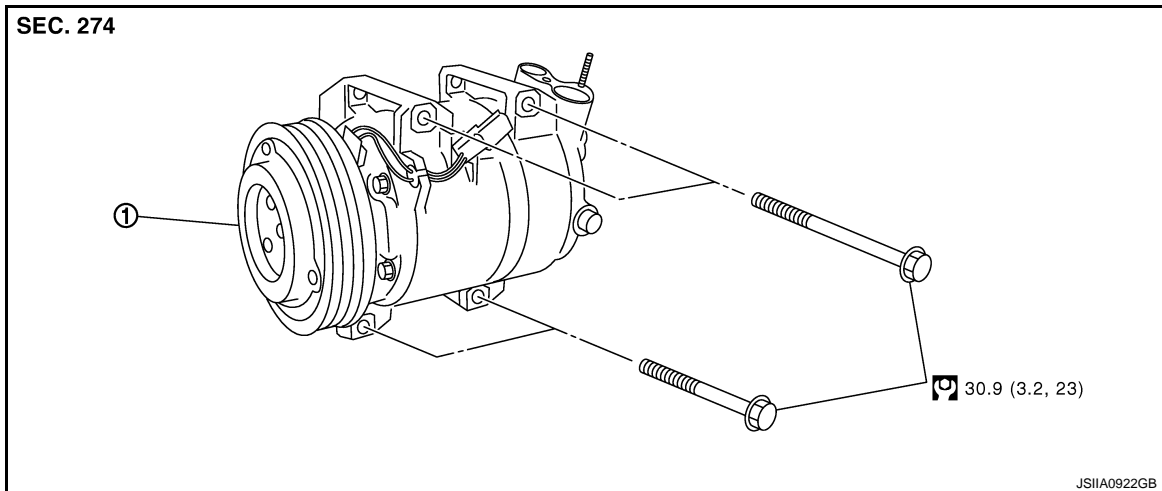

1. Compressor

Refer to [GI-4, "Components"](#) for symbols in the figure.

Removal and Installation

INFOID:000000001722458

REMOVAL

1. Use a refrigerant collecting equipment (for HFC-134a) to discharge the refrigerant.
2. Remove drive belt. Refer to [EM-15, "Exploded View"](#).
3. Remove mounting nut (A), and then disconnect low-pressure flexible hose (1) from compressor (2).

CAUTION:

Cap or wrap the joint of the A/C piping and compressor with suitable material such as vinyl tape to avoid the entry of air.

4. Remove mounting bolt (B), and then disconnect high-pressure flexible hose (3) from compressor.

CAUTION:

Cap or wrap the joint of the A/C piping and compressor with suitable material such as vinyl tape to avoid the entry of air.

5. Disconnect compressor (magnet clutch) connector (C).
6. Remove alternator. [CHG-19, "Exploded View"](#)
7. Remove mounting bolts (A) from compressor (1).

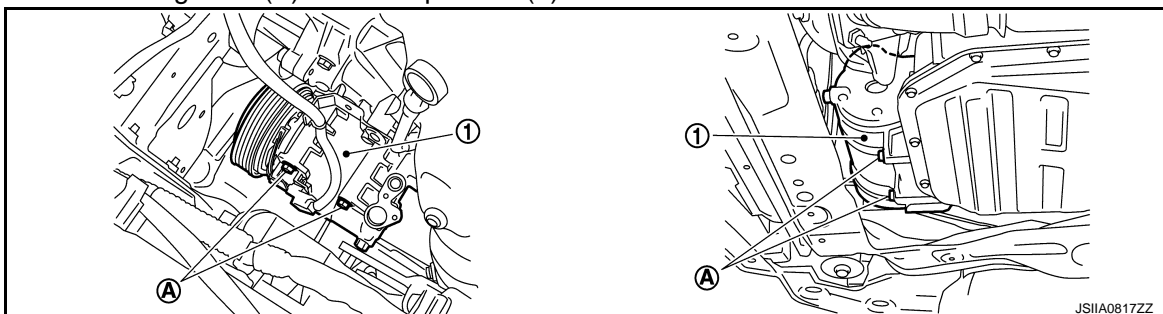
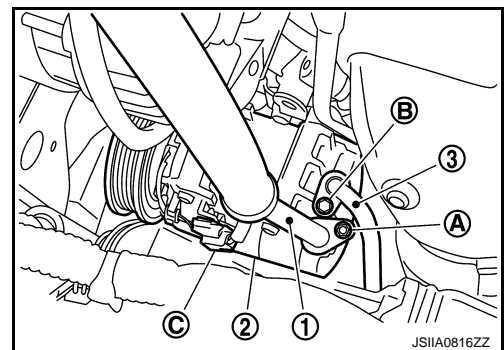

8. Remove compressor from top of the vehicle.

INSTALLATION

Installation is basically the reverse order of removal.

CAUTION:

- Replace O-rings with new ones. Then apply compressor oil to them when installing.

COMPRESSOR

< ON-VEHICLE REPAIR >

- Check for leakages when recharging refrigerant.

Inspection

INFOID:000000001722459

CHECK DISC TO PULLEY CLEARANCE

Check the clearance (B) between pulley assembly (1) and clutch disc (2) along the entire periphery with a feeler gauge (A).

Standard : Refer to [HA-58. "Compressor"](#).

Replace compressor if specified clearance is not obtained.

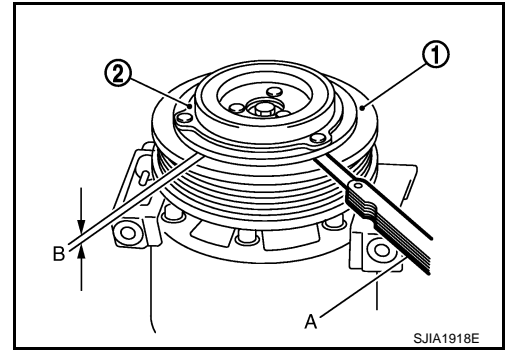

A
B
C
D
E
F
G
H
HA
J
K
L
M
N
O
P

HA

LOW-PRESSURE FLEXIBLE HOSE

< ON-VEHICLE REPAIR >

LOW-PRESSURE FLEXIBLE HOSE

Exploded View

INFOID:000000001766057

Refer to [HA-13, "FOR USA AND CANADA : Refrigerant Connection"](#) (FOR USA AND CANADA) or [HA-19, "FOR MEXICO : Refrigerant Connection"](#) (FOR MEXICO).

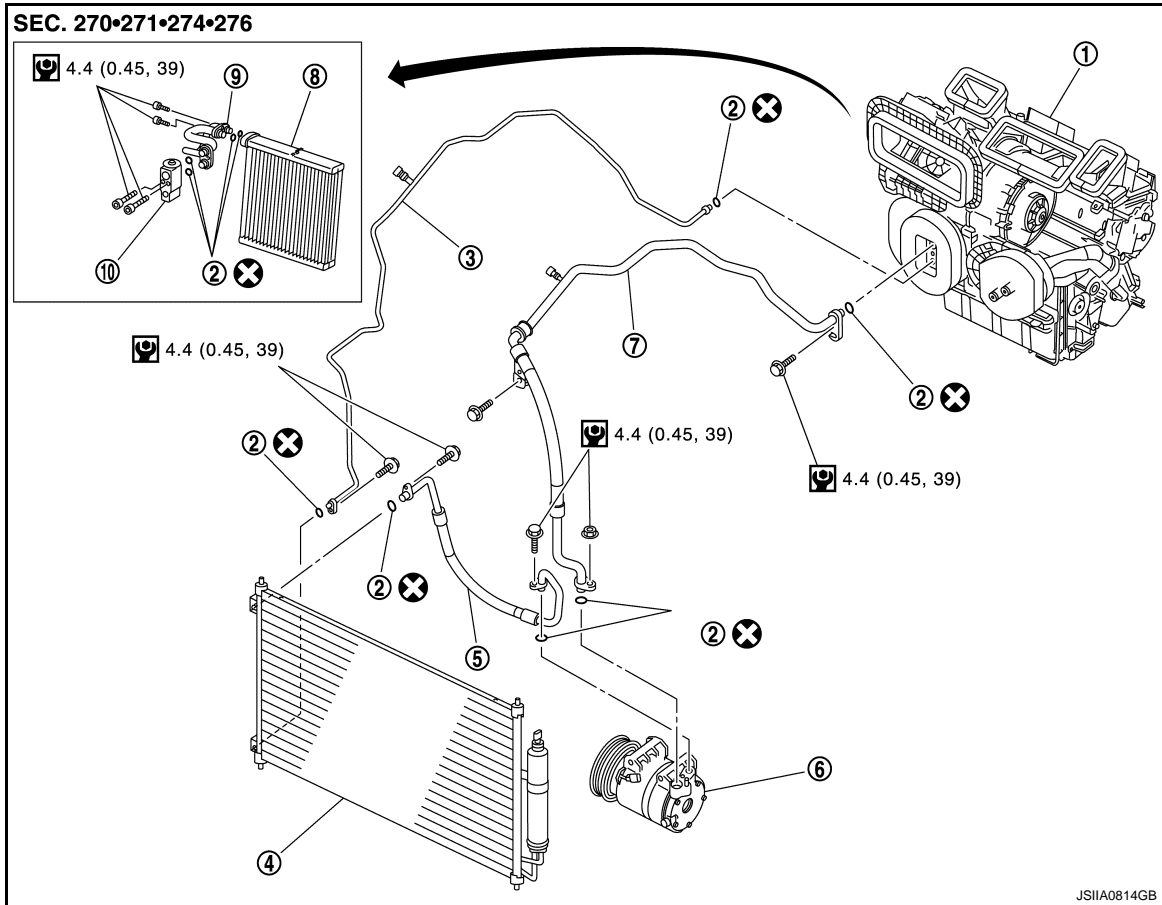

- | | | |
|-------------------------------|--------------------------------|-----------------------------|
| 1. A/C unit assembly | 2. O-ring | 3. High-pressure pipe |
| 4. Condenser | 5. High-pressure flexible hose | 6. Compressor |
| 7. Low-pressure flexible hose | 8. Evaporator | 9. Evaporator pipe assembly |
| 10. Expansion valve | | |

Refer to [GI-4, "Components"](#) for symbols in the figure.

Removal and Installation

INFOID:000000001722464

REMOVAL

1. Use a refrigerant collecting equipment (for HFC-134a) to discharge the refrigerant.
2. Remove cowl top cover. Refer to [EXT-20, "Exploded View"](#).

LOW-PRESSURE FLEXIBLE HOSE

< ON-VEHICLE REPAIR >

3. Remove mounting nut (A), and lower dash insulator (1) a position without the hindrance for work (as shown in the figure).

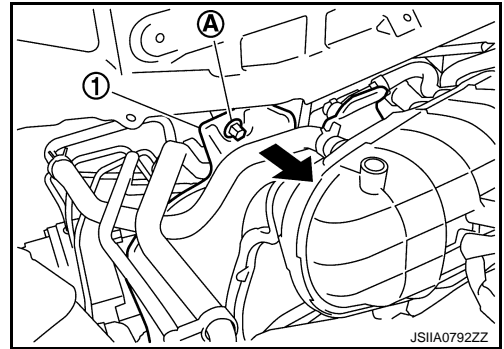

4. Remove mounting bolt (A), and then disconnect low-pressure flexible hose (1) from expansion valve.

CAUTION:

Cap or wrap the joint of the A/C piping and expansion valve with suitable material such as vinyl tape to avoid the entry of air.

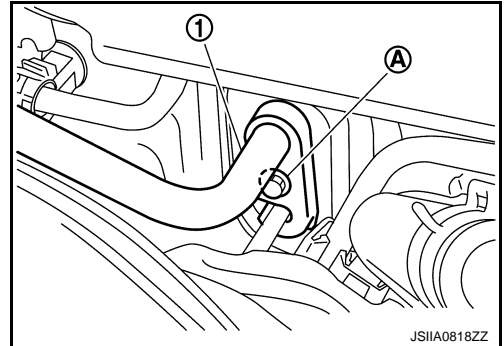

5. Remove mounting bolt (A) from low-pressure flexible hose bracket (1).

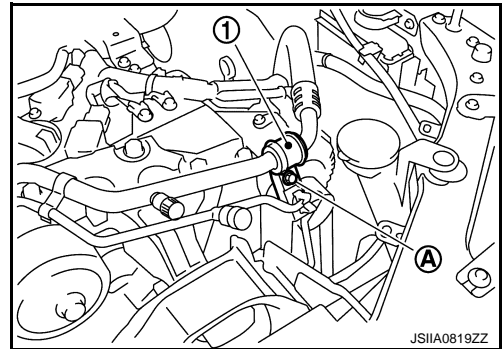

6. Remove mounting nut (A), and then disconnect low-pressure flexible hose (1) from compressor (2).

CAUTION:

Cap or wrap the joint of the A/C piping and compressor with suitable material such as vinyl tape to avoid the entry of air.

7. Remove low-pressure flexible hose.

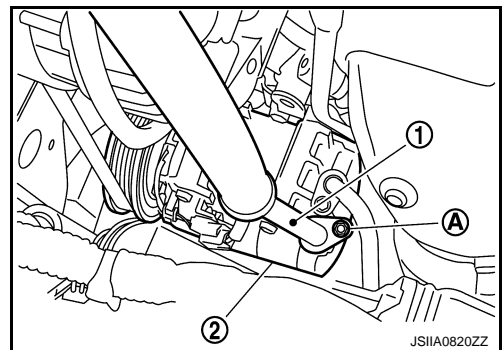

INSTALLATION

Installation is basically the reverse order of removal.

CAUTION:

- Replace O-rings with new ones. Then apply compressor oil to them when installing.
- Check for leakages when recharging refrigerant.

A
B
C
D
E
F
G
H
HA
J
K
L
M
N
O
P

HIGH-PRESSURE FLEXIBLE HOSE

< ON-VEHICLE REPAIR >

HIGH-PRESSURE FLEXIBLE HOSE

Exploded View

INFOID:000000001766058

Refer to [HA-13. "FOR USA AND CANADA : Refrigerant Connection"](#) (FOR USA AND CANADA) or [HA-19. "FOR MEXICO : Refrigerant Connection"](#) (FOR MEXICO).

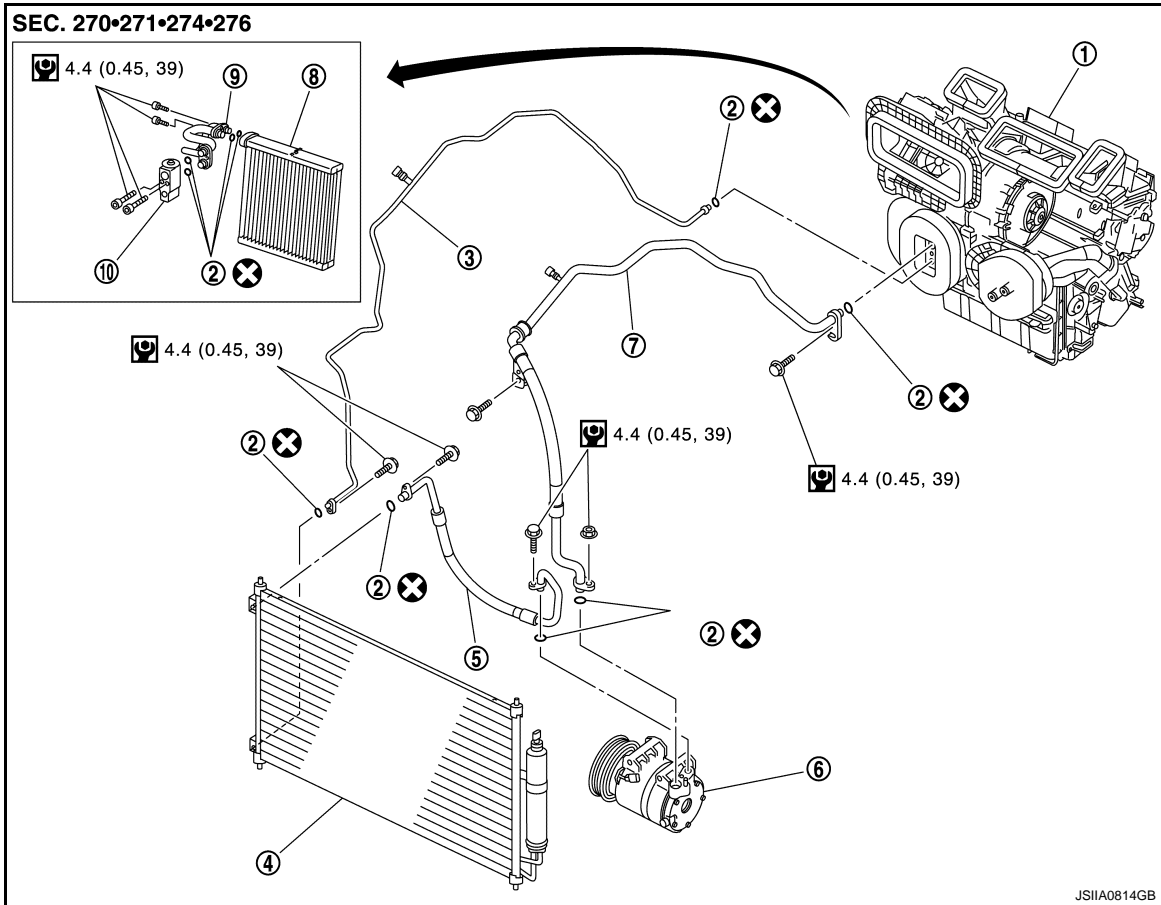

JSIIA0814GB

- | | | |
|-------------------------------|--------------------------------|-----------------------------|
| 1. A/C unit assembly | 2. O-ring | 3. High-pressure pipe |
| 4. Condenser | 5. High-pressure flexible hose | 6. Compressor |
| 7. Low-pressure flexible hose | 8. Evaporator | 9. Evaporator pipe assembly |
| 10. Expansion valve | | |

Refer to [GI-4. "Components"](#) for symbols in the figure.

Removal and Installation

INFOID:000000001722470

REMOVAL

1. Use a refrigerant collecting equipment (for HFC-134a) to discharge the refrigerant.
2. Remove mounting bolt (A), and then disconnect high-pressure flexible hose (1) from condenser.

CAUTION:

Cap or wrap the joint of the A/C piping and condenser with suitable material such as vinyl tape to avoid the entry of air.

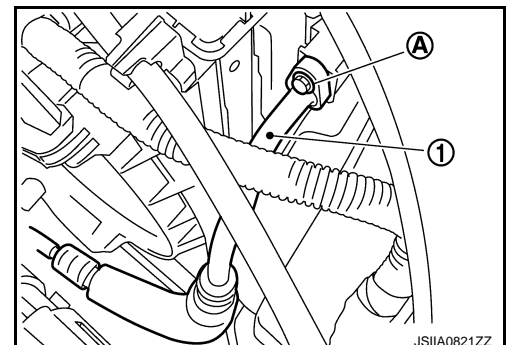

JSIIA0821ZZ

HIGH-PRESSURE FLEXIBLE HOSE

< ON-VEHICLE REPAIR >

3. Remove mounting bolt (A), and then remove high-pressure flexible hose (1) from compressor (2).

CAUTION:

Cap or wrap the joint of the A/C piping and compressor with suitable material such as vinyl tape to avoid the entry of air.

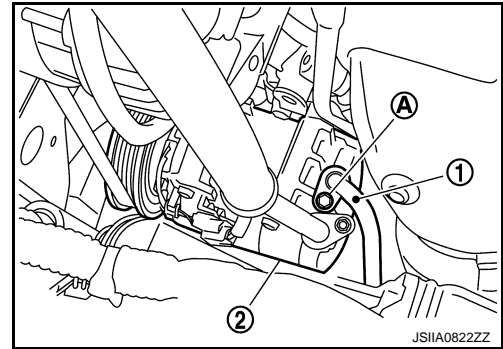

INSTALLATION

Installation is basically the reverse order of removal.

CAUTION:

- Replace O-rings with new ones. Then apply compressor oil to them when installing.
- Check for leakages when recharging refrigerant.

A
B
C
D
E
F
G
H
HA
J
K
L
M
N
O
P

HIGH-PRESSURE PIPE

< ON-VEHICLE REPAIR >

HIGH-PRESSURE PIPE

Exploded View

INFOID:000000001766060

Refer to [HA-13, "FOR USA AND CANADA : Refrigerant Connection"](#) (FOR USA AND CANADA) or [HA-19, "FOR MEXICO : Refrigerant Connection"](#) (FOR MEXICO).

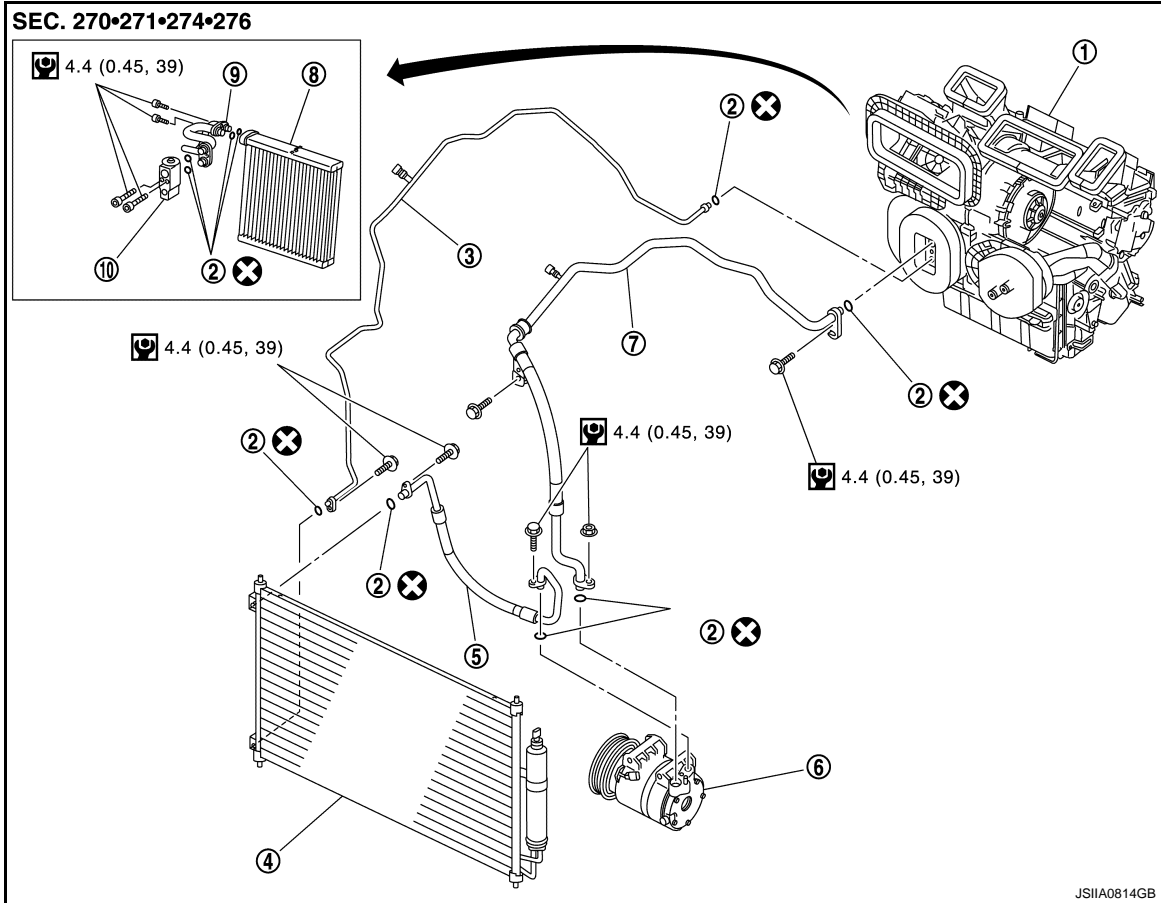

- | | | |
|-------------------------------|--------------------------------|-----------------------------|
| 1. A/C unit assembly | 2. O-ring | 3. High-pressure pipe |
| 4. Condenser | 5. High-pressure flexible hose | 6. Compressor |
| 7. Low-pressure flexible hose | 8. Evaporator | 9. Evaporator pipe assembly |
| 10. Expansion valve | | |

Refer to [GI-4, "Components"](#) for symbols in the figure.

Removal and Installation

INFOID:000000001722472

REMOVAL

1. Use a refrigerant collecting equipment (for HFC-134a) to discharge the refrigerant.
2. Remove cowl top cover. Refer to [EXT-20, "Exploded View"](#).

HIGH-PRESSURE PIPE

< ON-VEHICLE REPAIR >

3. Remove mounting nut (A), and lower dash insulator (1) a position without the hindrance for work (as shown in the figure).

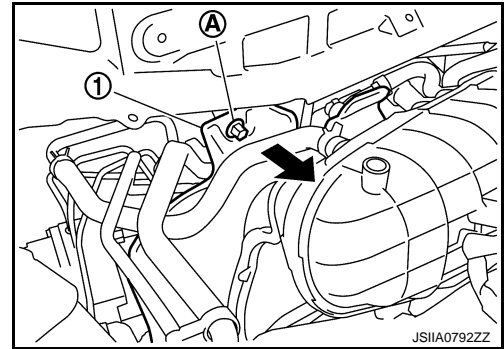

4. Remove mounting bolt (A), and then disconnect high-pressure pipe (1) from expansion valve.

CAUTION:

Cap or wrap the joint of the A/C piping and expansion valve with suitable material such as vinyl tape to avoid the entry of air.

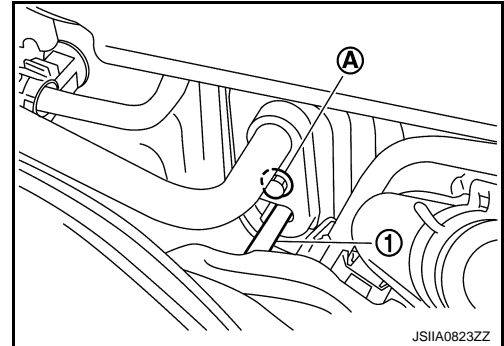

5. Remove high-pressure pipe (1) from vehicle clips (A).

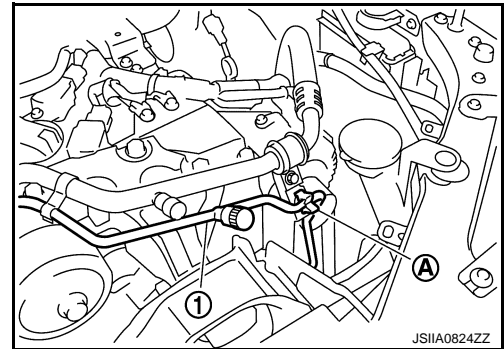

6. Remove mounting bolt (A), and then remove high-pressure pipe (1) from condenser.

CAUTION:

Cap or wrap the joint of the A/C piping and condenser with suitable material such as vinyl tape to avoid the entry of air.

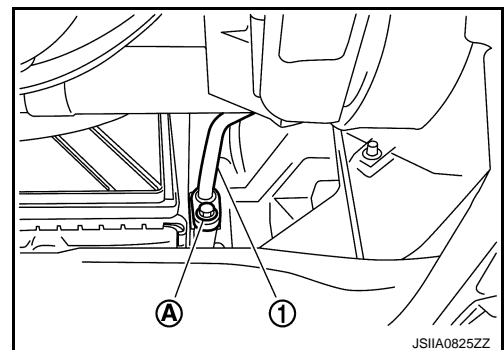

INSTALLATION

Installation is basically the reverse order of removal.

CAUTION:

- Replace O-rings with new ones. Then apply compressor oil to them when installing.
- Check for leakages when recharging refrigerant.

A
B
C
D
E
F
G
H
HA
J
K
L
M
N
O
P

CONDENSER

< ON-VEHICLE REPAIR >

CONDENSER

Exploded View

INFOID:000000001722477

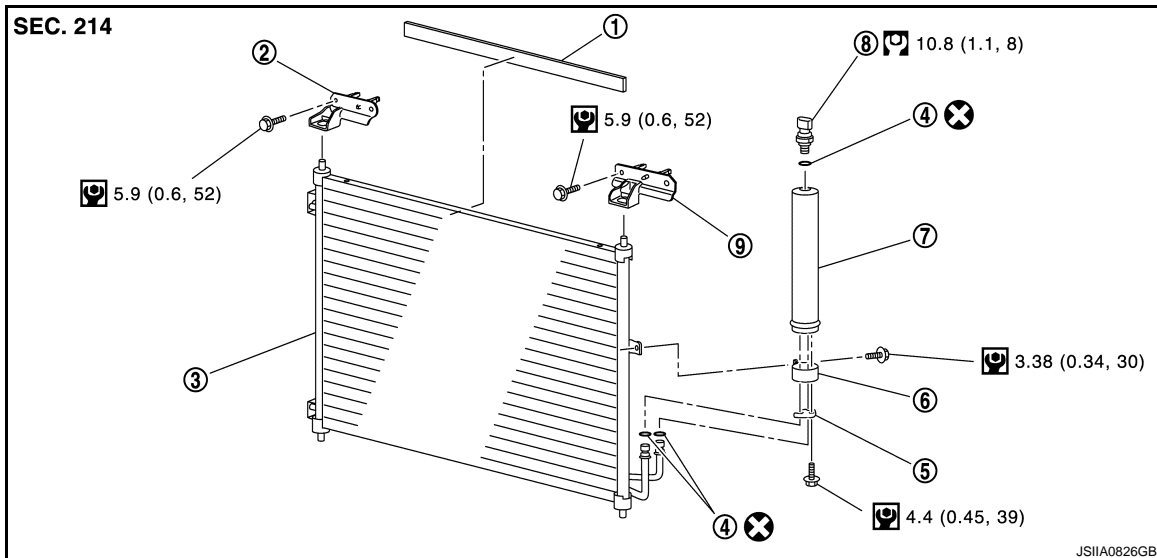

- | | | |
|----------------|--------------------------------|-------------------------------|
| 1. Seal | 2. Condenser upper bracket RH | 3. Condenser |
| 4. O-ring | 5. Bracket | 6. Liquid tank bracket |
| 7. Liquid tank | 8. Refrigerant pressure sensor | 9. Condenser upper bracket LH |

Refer to [GI-4, "Components"](#) for symbols in the figure.

Removal and Installation

INFOID:000000001722478

REMOVAL

1. Use a refrigerant collecting equipment (for HFC-134a) to discharge the refrigerant.
2. Remove mounting bolt (A), and then disconnect high-pressure flexible hose (1) from condenser.

CAUTION:

Cap or wrap the joint of the A/C piping and condenser with suitable material such as vinyl tape to avoid the entry of air.

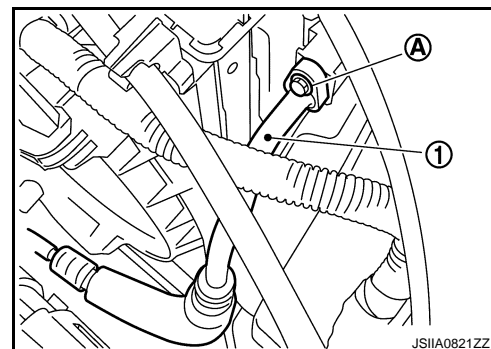

3. Remove mounting bolt (A), and then disconnect high-pressure pipe (1) from condenser.

CAUTION:

Cap or wrap the joint of the A/C piping and condenser with suitable material such as vinyl tape to avoid the entry of air.

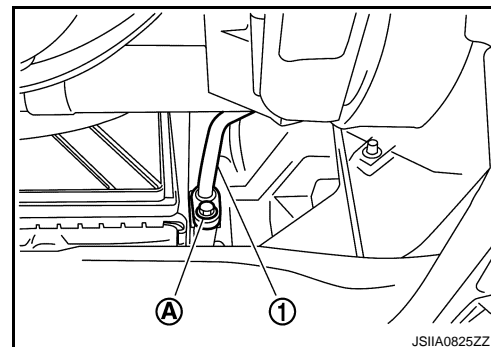

4. Remove air duct. Refer to [EM-27, "Exploded View"](#).

CONDENSER

< ON-VEHICLE REPAIR >

5. Remove mounting bolts (A), and then remove condenser upper bracket (LH/RH) (1).

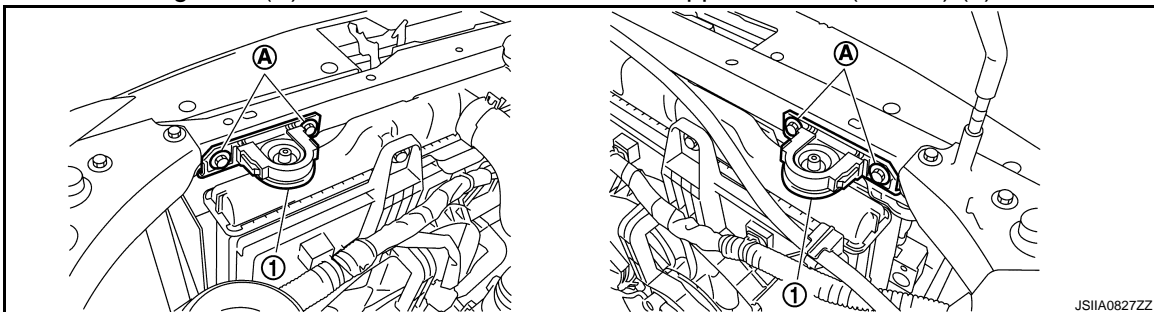

6. Disconnect connector from refrigerant pressure sensor (1).

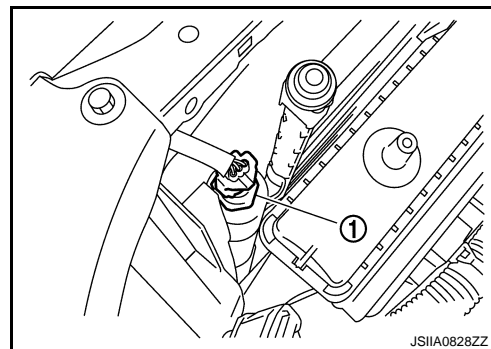

7. Remove condenser (1) between radiator and radiator core support (as shown in the figure).

CAUTION:

Be careful not to damage core surface of condenser and the radiator.

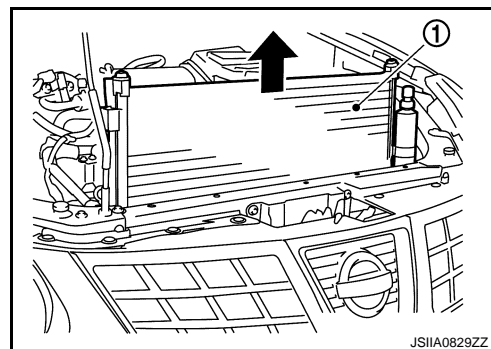

INSTALLATION

Installation is basically the reverse order of removal.

CAUTION:

- Replace O-rings with new ones. Then apply compressor oil to them when installing.
- Check for leakages when recharging refrigerant.

A
B
C
D
E
F
G
H
HA
J
K
L
M
N
O
P

LIQUID TANK

< ON-VEHICLE REPAIR >

LIQUID TANK

Exploded View

INFOID:000000001766523

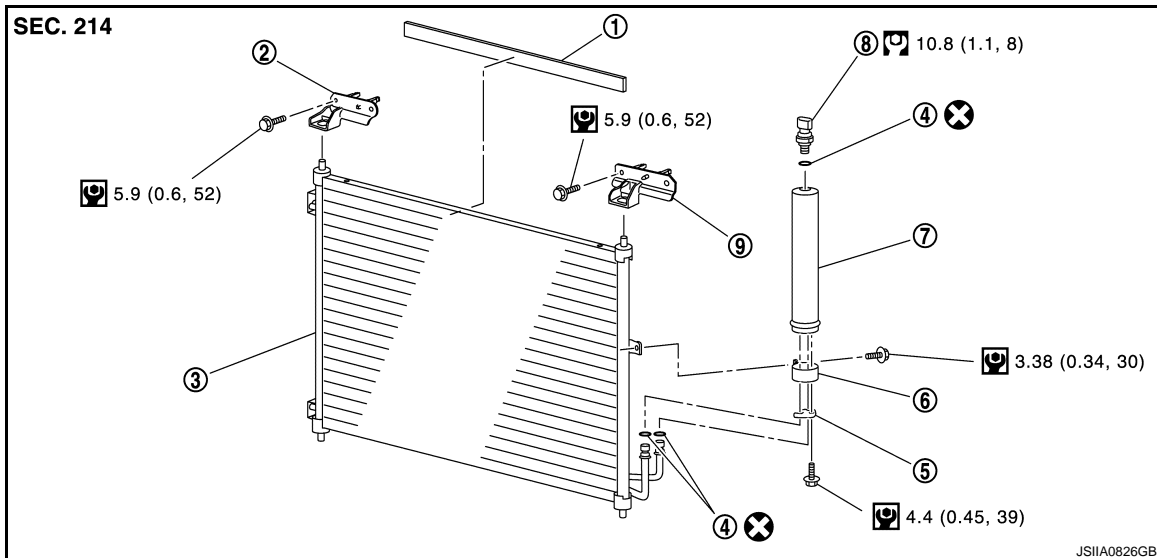

- | | | |
|----------------|--------------------------------|-------------------------------|
| 1. Seal | 2. Condenser upper bracket RH | 3. Condenser |
| 4. O-ring | 5. Bracket | 6. Liquid tank bracket |
| 7. Liquid tank | 8. Refrigerant pressure sensor | 9. Condenser upper bracket LH |

Refer to [GI-4, "Components"](#) for symbols in the figure.

Removal and Installation

INFOID:000000001722482

REMOVAL

1. Remove condenser. Refer to [HA-50, "Exploded View"](#).
2. Clean liquid tank and its surrounding area. Then remove dust and rust from liquid tank.

CAUTION:

Be sure to clean carefully.

3. Remove mounting bolts (A), and then remove liquid tank (1).

CAUTION:

Cap or wrap the joint of condenser and liquid tank with suitable material such as vinyl tape to avoid the entry of air.

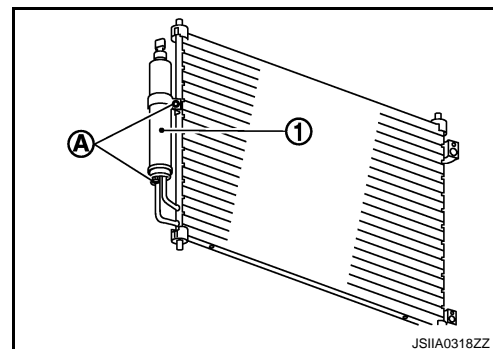

INSTALLATION

Install liquid tank, and then install liquid tank bracket on condenser.

CAUTION:

- Check that liquid tank bracket is securely installed at protrusion of condenser. (Check that liquid tank bracket does not move to a position below center of liquid tank.)
- Replace O-rings with new ones. Then apply compressor oil to them when installing.
- Check for leakages when recharging refrigerant.

REFRIGERANT PRESSURE SENSOR

< ON-VEHICLE REPAIR >

REFRIGERANT PRESSURE SENSOR

Exploded View

INFOID:000000001766524

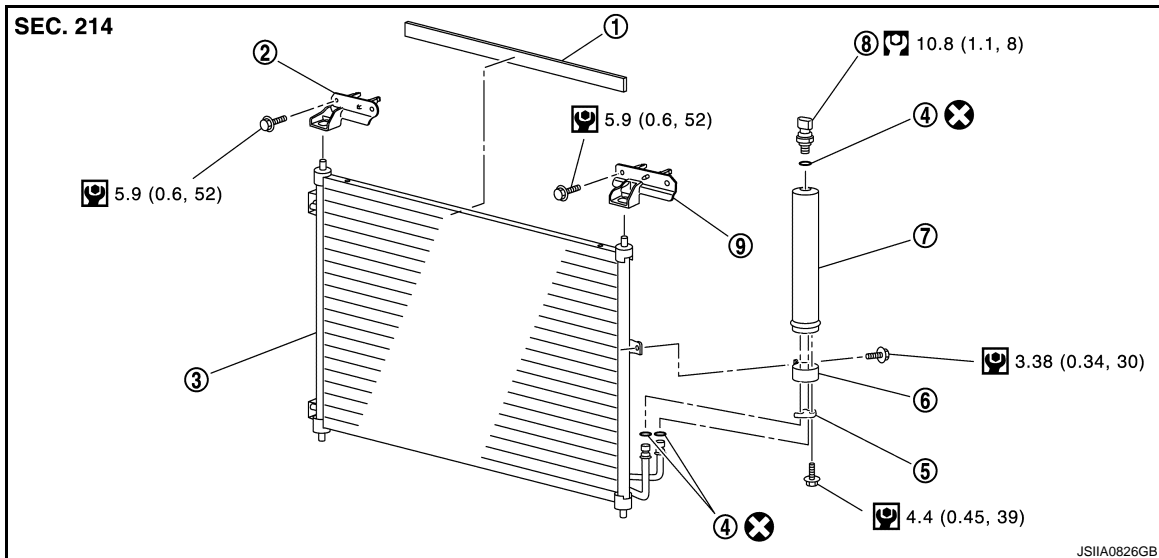

- | | | |
|----------------|--------------------------------|-------------------------------|
| 1. Seal | 2. Condenser upper bracket RH | 3. Condenser |
| 4. O-ring | 5. Bracket | 6. Liquid tank bracket |
| 7. Liquid tank | 8. Refrigerant pressure sensor | 9. Condenser upper bracket LH |

Refer to [GI-4, "Components"](#) for symbols in the figure.

Removal and Installation

INFOID:000000001722484

REMOVAL

1. Remove liquid tank. Refer to [HA-52, "Exploded View"](#).
2. Fix the liquid tank (1) with a vise (A). Remove the refrigerant pressure sensor (2) with a wrench (B).

CAUTION:

Be careful not to damage liquid tank.

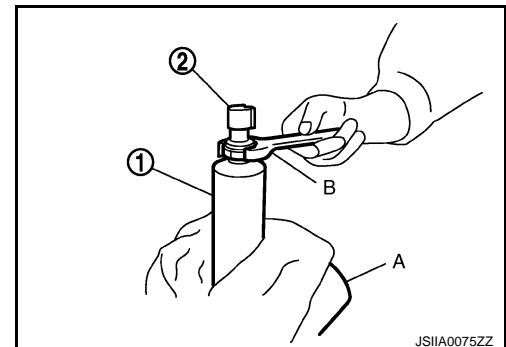

INSTALLATION

Installation is basically the reverse order of removal.

CAUTION:

- Apply compressor oil to O-ring of refrigerant pressure sensor when installing.
- Check for leakages when recharging refrigerant.

EVAPORATOR

< ON-VEHICLE REPAIR >

EVAPORATOR

Exploded View

INFOID:000000001754026

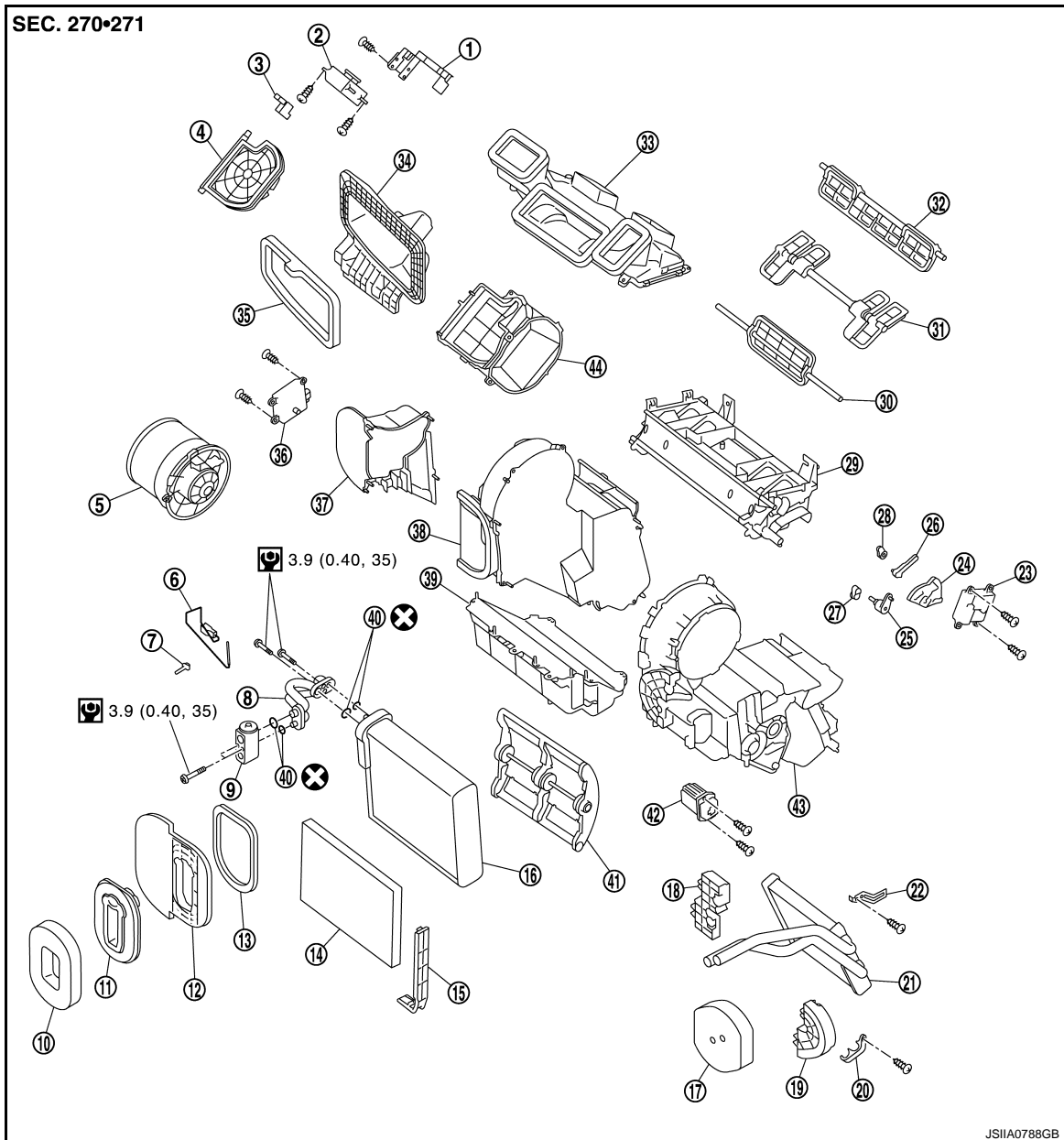

- | | | |
|------------------------------|------------------------------|--------------------------|
| 1. Intake door motor bracket | 2. Intake door motor | 3. Intake door lever |
| 4. Intake door | 5. Blower motor | 6. Intake sensor |
| 7. Intake sensor bracket | 8. Evaporator pipe assembly | 9. Expansion valve |
| 10. Expansion valve packing | 11. Expansion valve grommet | 12. Grommet adaptor |
| 13. Adaptor packing | 14. In-cabin microfilter | 15. Filter cover |
| 16. Evaporator | 17. Heater packing | 18. Heater adapter |
| 19. Heater pipe flange | 20. Heater pipe clamp | 21. Heater core |
| 22. Case bracket | 23. Mode door motor | 24. Main link |
| 25. Ventilator door lever | 26. Foot door link | 27. Defroster door lever |
| 28. Foot door lever | 29. Distributor module case | 30. Defroster door |
| 31. Ventilator door | 32. Foot door | 33. Adaptor duct |
| 34. Attachment panel | 35. Attachment panel packing | 36. Air mix door motor |

EVAPORATOR

< ON-VEHICLE REPAIR >

- | | | |
|------------------|-------------------------------|----------------------|
| 37. Side case | 38. Main case RH | 39. Lower case |
| 40. O-ring | 41. Air mix door (Slide door) | 42. Fan control amp. |
| 43. Main case LH | 44. Intake box case | |

Refer to [GI-4, "Components"](#) for symbols in the figure.

Removal and Installation

INFOID:000000001722486

REMOVAL

1. Remove A/C unit assembly. Refer to [VTL-32, "Exploded View"](#).
2. Remove air conditioner filter cover (1).
3. Remove mounting screws (A), and then remove lower case (2).

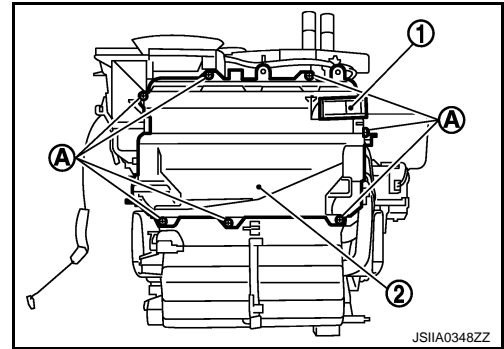

4. Remove mounting screws (A), and then remove side case (1).
5. Remove evaporator (2).

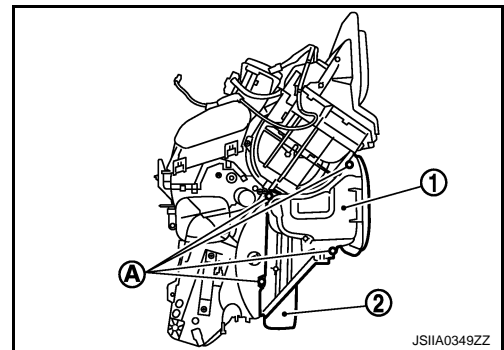

6. Cut upper insulator (1) and remove mounting bolts (A), expansion valve (2) and evaporator pipe assembly (3), from evaporator (4).

CAUTION:

Cap or wrap the joint of A/C piping, evaporator and expansion valve with suitable material such as vinyl tape to avoid the entry of air.

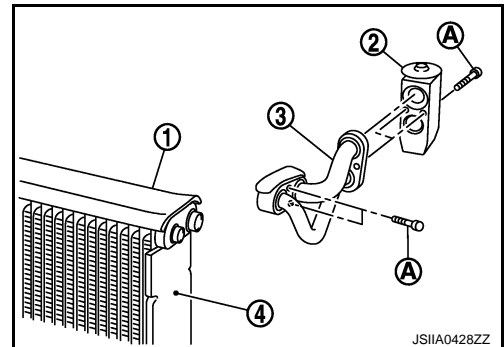

INSTALLATION

Installation is basically the reverse order of removal.

CAUTION:

- Replace O-rings with new ones. Then apply compressor oil to them when installing.
- O-rings differ from high-pressure pipe (low-pressure pipe or low-pressure flexible hose) and evaporator pipe assembly.
- Mark the mounting position of intake sensor bracket prior to removal so that the reinstalled sensor can be located in the same position.
- Check for leakages when recharging refrigerant.

NOTE:

Refer to [CO-10, "Refilling"](#), when filling radiator with engine coolant.

EXPANSION VALVE

< ON-VEHICLE REPAIR >

EXPANSION VALVE

Exploded View

INFOID:000000001754027

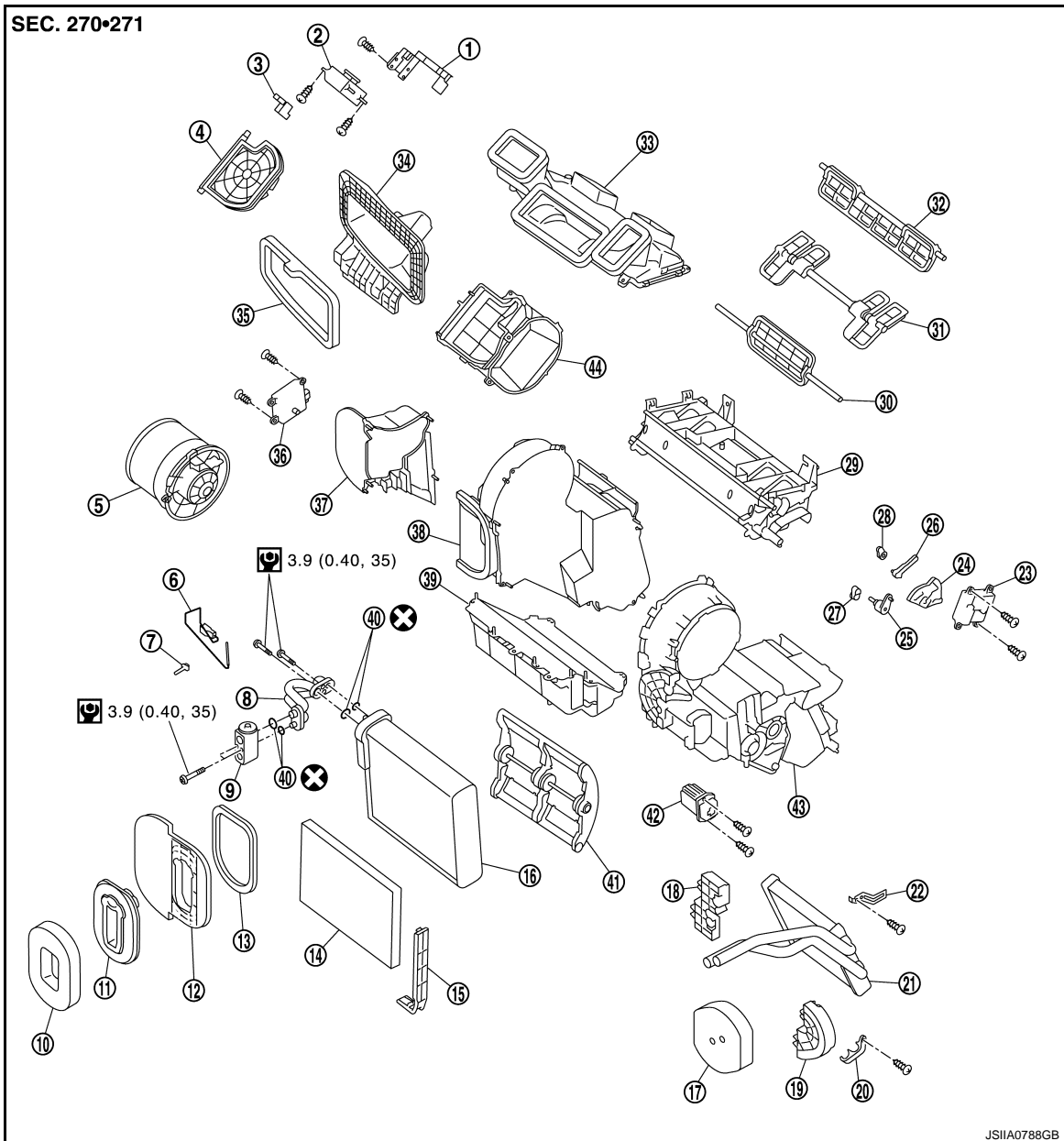

- | | | |
|------------------------------|------------------------------|--------------------------|
| 1. Intake door motor bracket | 2. Intake door motor | 3. Intake door lever |
| 4. Intake door | 5. Blower motor | 6. Intake sensor |
| 7. Intake sensor bracket | 8. Evaporator pipe assembly | 9. Expansion valve |
| 10. Expansion valve packing | 11. Expansion valve grommet | 12. Grommet adaptor |
| 13. Adaptor packing | 14. In-cabin microfilter | 15. Filter cover |
| 16. Evaporator | 17. Heater packing | 18. Heater adapter |
| 19. Heater pipe flange | 20. Heater pipe clamp | 21. Heater core |
| 22. Case bracket | 23. Mode door motor | 24. Main link |
| 25. Ventilator door lever | 26. Foot door link | 27. Defroster door lever |
| 28. Foot door lever | 29. Distributor module case | 30. Defroster door |
| 31. Ventilator door | 32. Foot door | 33. Adaptor duct |
| 34. Attachment panel | 35. Attachment panel packing | 36. Air mix door motor |

EXPANSION VALVE

< ON-VEHICLE REPAIR >

- | | | |
|------------------|-------------------------------|----------------------|
| 37. Side case | 38. Main case RH | 39. Lower case |
| 40. O-ring | 41. Air mix door (Slide door) | 42. Fan control amp. |
| 43. Main case LH | 44. Intake box case | |

Refer to [GI-4. "Components"](#) for symbols in the figure.

Removal and Installation

INFOID:000000001722488

REMOVAL

1. Use a refrigerant collecting equipment (for HFC-134a) to discharge the refrigerant.
2. Remove cowl top cover. Refer to [EXT-20. "Exploded View"](#).
3. Remove mounting nut (A), and lower dash insulator (1) a position without the hindrance for work (as shown in the figure).

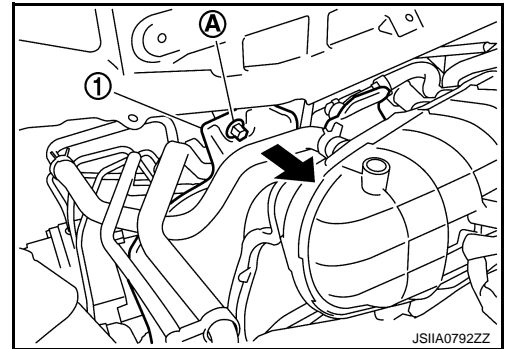

4. Remove mounting bolt (A), and then disconnect low-pressure flexible hose (1) and high-pressure pipe (2) from expansion valve.

CAUTION:

Cap or wrap the joint of the A/C piping with suitable material such as vinyl tape to avoid the entry of air.

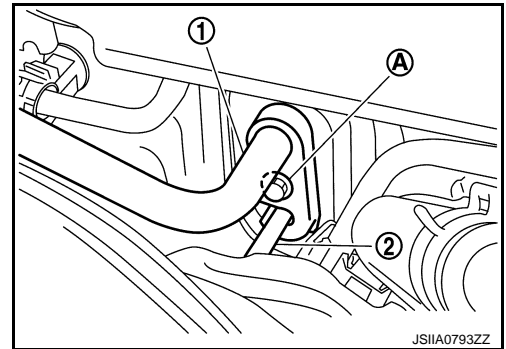

5. Remove mounting bolts (A), and then remove expansion valve (1).

CAUTION:

Cap or wrap the joint of the A/C piping with suitable material such as vinyl tape to avoid the entry of air.

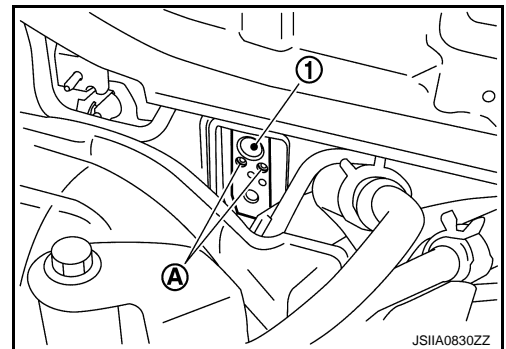

INSTALLATION

Installation is basically the reverse order of removal.

CAUTION:

- Replace O-rings new ones. Then apply compressor oil to them when installing.
- Check for leakages when recharging refrigerant.

A
B
C
D
E
F
G
H
HA
J
K
L
M
N
O
P

SERVICE DATA AND SPECIFICATIONS (SDS)

< SERVICE DATA AND SPECIFICATIONS (SDS)

SERVICE DATA AND SPECIFICATIONS (SDS)

SERVICE DATA AND SPECIFICATIONS (SDS)

Compressor

INFOID:000000001722492

Model	VALEO THERMAL SYSTEMS JAPAN make DCS-17D	
Type	Fixed displacement swash plate	
Displacement cm ³ (cu in)/rev	Max.	175 (10.7)
Cylinder bore × stroke (Max.) mm (in.)	30.5 (1.21) × 24.0 (0.95)	
Direction of rotation	Clockwise (viewed from clutch)	
Drive belt	Poly V	
Disc to pulley clearance	Standard	0.3 - 0.7 mm (0.012 - 0.028 in)

Lubricant

INFOID:000000001722493

Model	VALEO THERMAL SYSTEMS JAPAN make DCS-17D	
Name	Nissan A/C System Oil Type S (DH-PS)	
Capacity mℓ (US fl oz, Imp fl oz)	Total in system	150 (5.03, 5.3)
	Compressor (service part) charging amount	150 (5.03, 5.3)

Refrigerant

INFOID:000000001722494

Type	HFC-134a (R-134a)
Capacity kg (lb)	0.50 (1.11)

Engine Idling Speed

INFOID:000000001722495

Refer to [EC-491, "Idle Speed"](#) (FOR CALIFORNIA), [EC-920, "Idle Speed"](#) [FOR USA (FEDERAL) AND CANADA] or [EC-1274, "Idle Speed"](#) (FOR MEXICO).

Belt Tension

INFOID:000000001722496

Refer to [EM-15, "Tension Adjustment"](#).