



# DIAGNOSIS AND REPAIR WORKFLOW

< BASIC INSPECTION >

## BASIC INSPECTION

### DIAGNOSIS AND REPAIR WORKFLOW

Work Flow

INFOID:000000004233753

#### OVERALL SEQUENCE

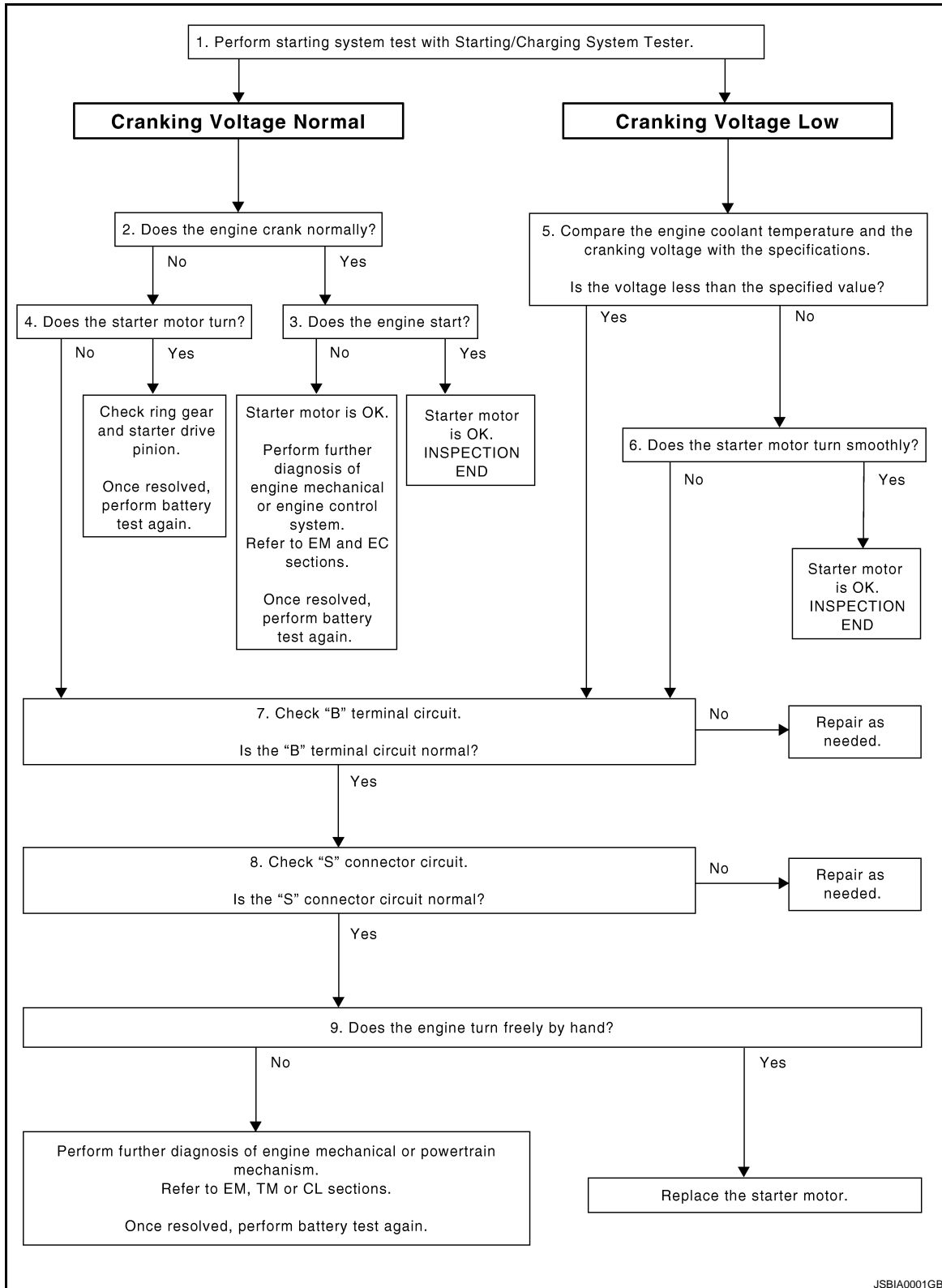

#### DETAILED FLOW

# DIAGNOSIS AND REPAIR WORKFLOW

## < BASIC INSPECTION >

### NOTE:

To ensure a complete and thorough diagnosis, the battery, starter motor and alternator test segments must be done as a set from start to finish.

## 1. DIAGNOSIS WITH STARTING/CHARGING SYSTEM TESTER

Perform the starting system test with Starting/Charging System Tester (SST: J-44373). For details and operating instructions, refer to Technical Service Bulletin.

### Test result

CRANKING VOLTAGE NORMAL>>GO TO 2.

CRANKING VOLTAGE LOW>>GO TO 5.

CHARGE BATTERY>>Perform the slow battery charging procedure. (Initial rate of charge is 10A for 12 hours.) Perform battery test again. Refer to Technical Service Bulletin.

REPLACE BATTERY>>Before replacing battery, clean the battery cable clamps and battery posts. Perform battery test again. Refer to Technical Service Bulletin. If second test result is "REPLACE BATTERY", then do so. Perform battery test again to confirm repair.

## 2. CRANKING CHECK

Check that the starter motor operates correctly.

### Does the engine crank normally?

YES >> GO TO 3.

NO >> GO TO 4.

## 3. ENGINE START CHECK

Check that the engine starts.

### Does the engine start?

YES >> Starter motor is OK. INSPECTION END

NO >> Perform further diagnosis of engine mechanical or engine control system. Refer EM and EC sections. Once resolved, perform battery test again.

## 4. STARTER MOTOR ACTIVATION

Check that the starter motor operates.

### Does the starter motor turn?

YES >> Check ring gear and starter motor drive pinion. Once resolved, perform battery test again.

NO >> GO TO 7.

## 5. COMPARISON BETWEEN ENGINE COOLANT AND CRANKING VOLTAGE

Compare the engine coolant temperature and the cranking voltage with the specifications.

Minimum Specification of Cranking Voltage Referencing Coolant Temperature

Engine coolant temperature [°C (°F)]	Voltage [V]
-30 to -20 (-22 to -4)	8.6
-19 to -10 (-2 to 14)	9.1
-9 to 0 (16 to 32)	9.5
More than 1 (More than 34)	9.9

### Is the voltage less than the specified value?

YES >> GO TO 7.

NO >> GO TO 6.

## 6. STARTER OPERATION

Check the starter operation status.

### Does the starter motor turn smoothly?

YES >> Starter motor is OK. INSPECTION END

NO >> GO TO 7.

## 7. "B" TERMINAL CIRCUIT INSPECTION

Check "B" terminal circuit. Refer to [STR-7, "Diagnosis Procedure"](#).

### Is "B" terminal circuit normal?

A

STR

C

D

E

F

G

H

I

J

K

L

M

N

O

P

## DIAGNOSIS AND REPAIR WORKFLOW

### < BASIC INSPECTION >

---

- YES >> GO TO 8.
- NO >> Repair as needed.

### 8. "S" CONNECTOR CIRCUIT INSPECTION

---

Check "S" connector circuit. Refer to [STR-8. "Diagnosis Procedure"](#).

#### Is "S" connector circuit normal?

- YES >> GO TO 9.
- NO >> Repair as needed.

### 9. ENGINE ROTATION STATUS

---

Check that the engine can be rotated by hand.

#### Does the engine turn freely by hand?

- YES >> Replace starter motor.
- NO >> Perform further diagnosis of engine mechanical or powertrain mechanism. Refer to EM, TM or CL sections. Once resolved, perform battery test again. Refer to Technical Service Bulletin.

# STARTING SYSTEM

< FUNCTION DIAGNOSIS >

## FUNCTION DIAGNOSIS

### STARTING SYSTEM

#### System Diagram

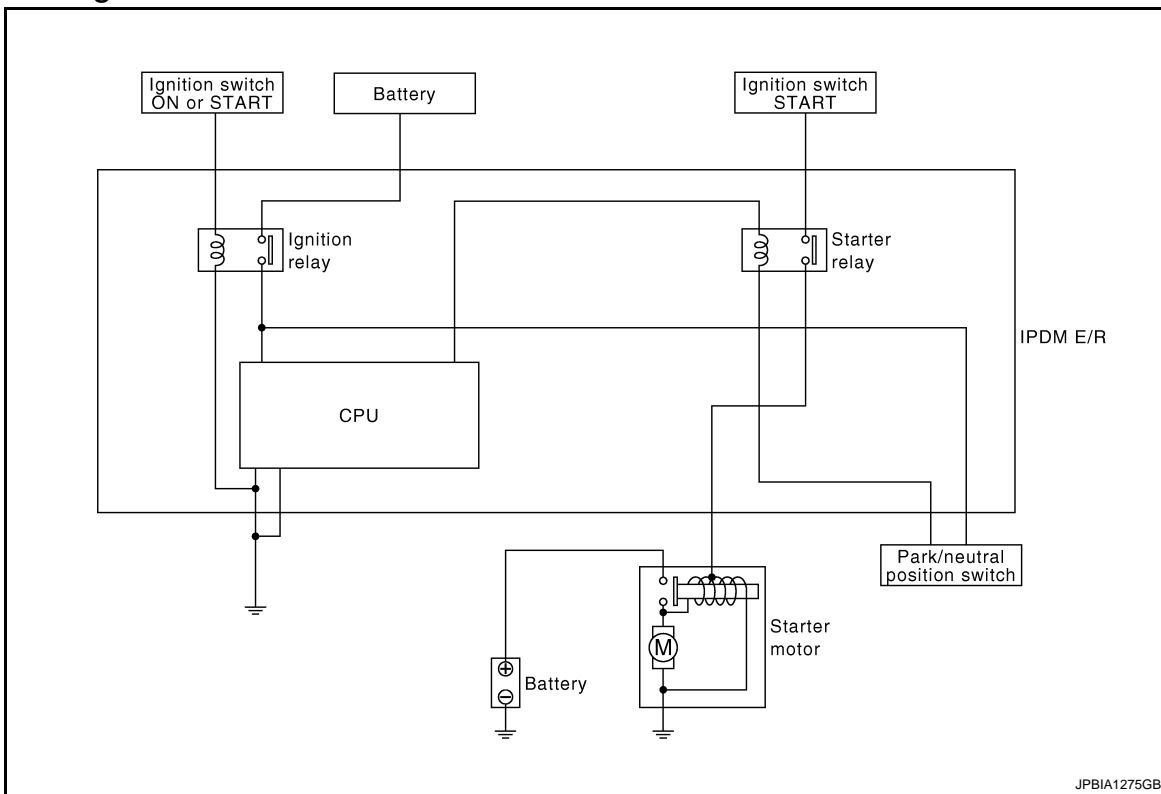

#### System Description

INFOID:000000004233755

The starter motor plunger closes and provides a closed circuit between the battery and starter motor. The starter motor is grounded to the engine block. With power and ground supplied, cranking occurs and the engine starts.

A

STR

C

D

E

F

G

H

I

J

K

L

M

N

O

P

# STARTING SYSTEM

< FUNCTION DIAGNOSIS >

## Component Parts Location

INFOID:000000004233756

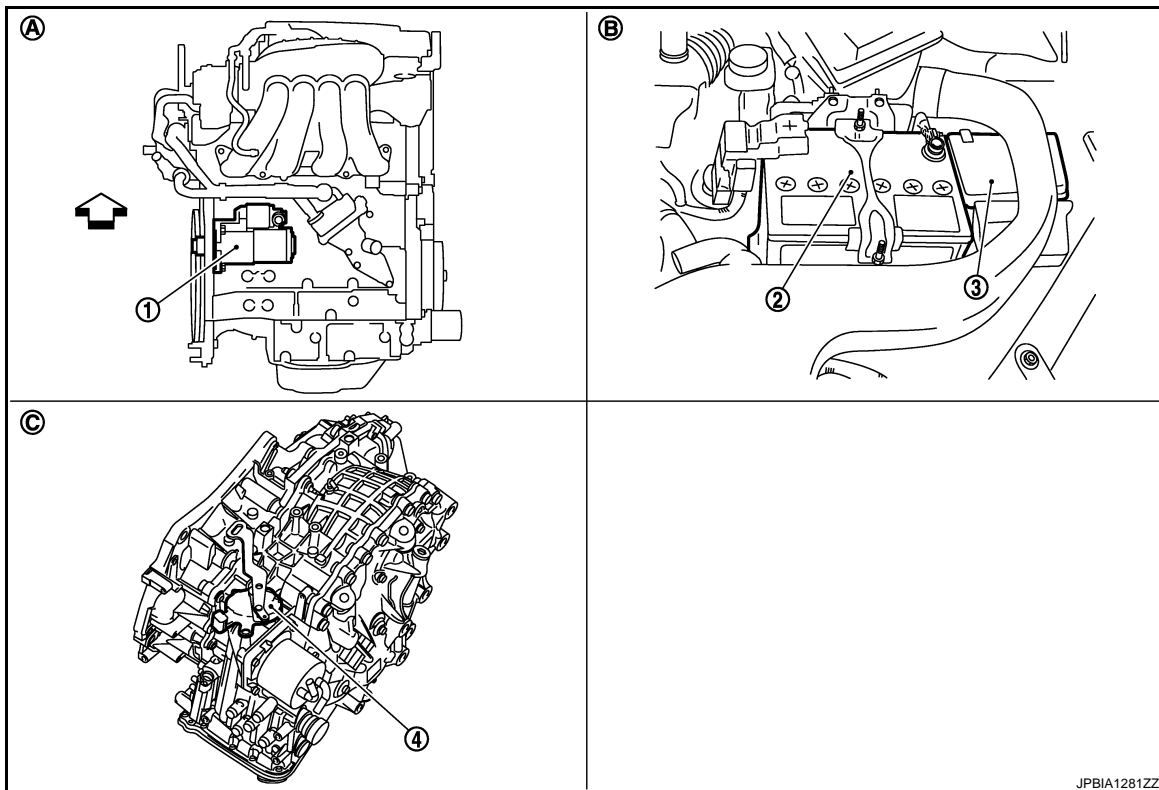

JPBIA1281ZZ

- |                                 |                     |                 |
|---------------------------------|---------------------|-----------------|
| 1. Starter motor                | 2. Battery          | 3. IPDM E/R     |
| 4. Park/neutral position switch |                     |                 |
| A. Engine                       | B. Engine room (LH) | C. CVT assembly |
| : Vehicle front                 |                     |                 |

## Component Description

INFOID:000000004233757

Component part	Description
Park/neutral position switch	Park/neutral position switch supplies power to the starter relay inside IPDM E/R when the selector lever is shifted to the P or N position.
IPDM E/R	CPU inside IPDM E/R controls the starter relay. Ignition relay inside IPDM E/R supplies power to the park/neutral position switch when ignition switch is ON or START.
Starter motor	The starter motor plunger closes and the motor is supplied with battery power, which in turn cranks the engine, when the "S" terminal is supplied with electric power.

# B TERMINAL CIRCUIT

< COMPONENT DIAGNOSIS >

## COMPONENT DIAGNOSIS

### B TERMINAL CIRCUIT

#### Description

INFOID:0000000004233758

STR

The "B" terminal is constantly supplied with battery power.

#### Diagnosis Procedure

INFOID:0000000004233759

#### CAUTION:

Perform diagnosis under the condition that engine cannot start by the following procedure.

1. Remove fuel pump fuse.
2. Crank or start the engine (where possible) until the fuel pressure is released.

#### 1. CHECK "B" TERMINAL CIRCUIT

1. Turn ignition switch OFF.
2. Check that starter motor "B" terminal connection is clean and tight.
3. Check voltage between starter motor "B" terminal and ground.

Terminals			Voltage (Approx.)
(+)	(-)		
Starter motor "B" terminal	Terminal		Battery voltage
F49	2		
		Ground	

Is the inspection result normal?

YES >> GO TO 2.

NO >> Check harness between battery and starter motor for open circuit.

#### 2. CHECK BATTERY CABLE CONNECTION STATUS (VOLTAGE DROP TEST)

1. Shift CVT selector lever to "P" or "N" position.
2. Check voltage between battery positive terminal and starter motor "B" terminal.

Terminals			Condition	Voltage (Approx.)
(+)	(-)			
	Starter motor "B" terminal	Terminal	When the ignition switch is in START position	Less than 0.5 V
Battery positive terminal	F49	2		

Is the inspection result normal?

YES >> GO TO 3.

NO >> Check harness between the battery and the starter motor for poor continuity.

#### 3. CHECK GROUND CIRCUIT STATUS (VOLTAGE DROP TEST)

1. Shift CVT selector lever to "P" or "N" position.
2. Check voltage between starter motor case and battery negative terminal.

Terminals		Condition	Voltage (Approx.)
(+)	(-)		
Starter motor case	Battery negative terminal	When the ignition switch is in START position	Less than 0.2 V

Is the inspection result normal?

YES >> "B" terminal circuit is OK. Further inspection is necessary. Refer to [STR-2, "Work Flow"](#).

NO >> Check the starter motor case and ground for poor continuity.

# S CONNECTOR CIRCUIT

< COMPONENT DIAGNOSIS >

## S CONNECTOR CIRCUIT

### Description

INFOID:000000004233760

The starter motor magnetic switch is supplied with power when the ignition switch is turned to START with the selector lever "P" or "N" position.

### Diagnosis Procedure

INFOID:000000004233761

#### CAUTION:

Perform diagnosis under the condition that engine cannot start by the following procedure.

1. Remove fuel pump fuse.
2. Crank or start the engine (where possible) until the fuel pressure is released.

#### 1. CHECK "S" CONNECTOR CIRCUIT

1. Turn ignition switch OFF.
2. Disconnect starter motor connector.
3. Shift CVT selector lever to "P" or "N" position.
4. Check voltage between starter motor harness connector and ground.

Terminals		Condition	Voltage (Approx.)
(+)	(-)		
Starter motor harness connector	Terminal		
F47	1	When the ignition switch is in START position	Battery voltage

Is the inspection result normal?

- YES >> "S" connector circuit is OK. Further inspection is necessary. Refer to [STR-2. "Work Flow"](#).  
NO >> GO TO 2.

#### 2. CHECK CONNECTOR

1. Turn ignition switch OFF.
2. Check the following terminals and connectors for damage, bend and loose connection.
  - Harness connector E8
  - Harness connector F122

Is the inspection result normal?

- YES >> GO TO 3.  
NO >> Repair the terminal and connector.

#### 3. CHECK HARNESS CONTINUITY (OPEN CIRCUIT)

1. Disconnect IPDM E/R connector.
2. Check continuity between starter motor harness connector and IPDM E/R harness connector.

Starter motor harness connector		IPDM E/R harness connector		Continuity
Connector No.	Terminal No.	Connector No.	Terminal No.	
F47	1	E10	3	Existed

Is the inspection result normal?

- YES >> Inspect IPDM E/R and power supply circuit. Refer to [SEC-6. "Work Flow"](#).  
NO >> Repair the harness.



# STARTING SYSTEM

< COMPONENT DIAGNOSIS >

## STARTING SYSTEM

### Wiring Diagram - STARTING SYSTEM -

INFOID:000000004233762

A

STR

C

D

E

F

G

H

I

J

K

L

M

N

O

P

### STARTING SYSTEM

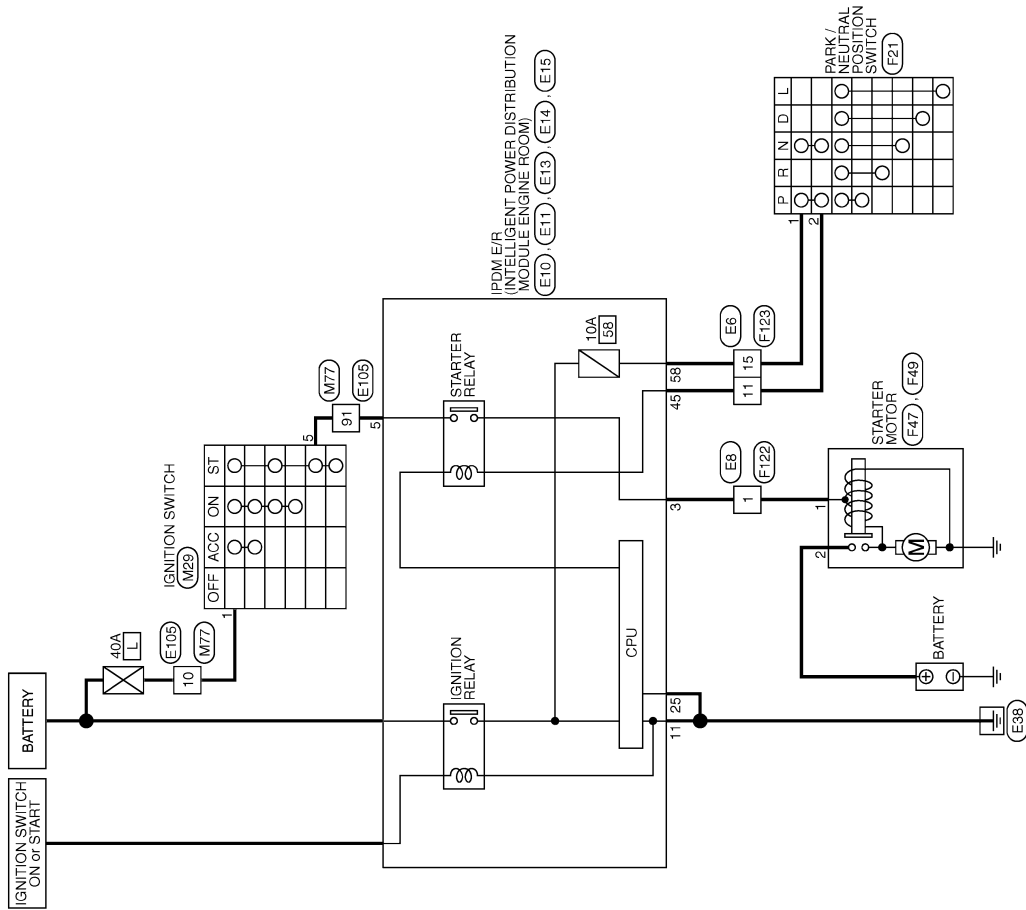











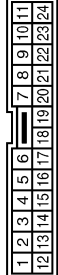



2008/07/15

JCBWM0970GI

# STARTING SYSTEM

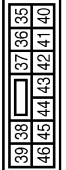
## < COMPONENT DIAGNOSIS >

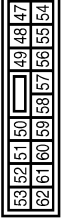
### STARTING SYSTEM









<table border="1"> <tr> <td>Connector No.</td> <td>E6</td> </tr> <tr> <td>Connector Name</td> <td>WIRE TO WIRE</td> </tr> <tr> <td>Connector Type</td> <td>TK2AW-1V</td> </tr> </table>  	Connector No.	E6	Connector Name	WIRE TO WIRE	Connector Type	TK2AW-1V	<table border="1"> <tr> <td>Terminal No.</td> <td>11</td> <td>15</td> </tr> <tr> <td>Color of Wire</td> <td>Y</td> <td>LG</td> </tr> <tr> <td>Signal Name [Specification]</td> <td></td> <td></td> </tr> </table>	Terminal No.	11	15	Color of Wire	Y	LG	Signal Name [Specification]		
Connector No.	E6															
Connector Name	WIRE TO WIRE															
Connector Type	TK2AW-1V															
Terminal No.	11	15														
Color of Wire	Y	LG														
Signal Name [Specification]																
<table border="1"> <tr> <td>Connector No.</td> <td>E8</td> </tr> <tr> <td>Connector Name</td> <td>WIRE TO WIRE</td> </tr> <tr> <td>Connector Type</td> <td>M02AW-LC</td> </tr> </table>  	Connector No.	E8	Connector Name	WIRE TO WIRE	Connector Type	M02AW-LC	<table border="1"> <tr> <td>Terminal No.</td> <td>1</td> </tr> <tr> <td>Color of Wire</td> <td>O</td> </tr> <tr> <td>Signal Name [Specification]</td> <td></td> </tr> </table>	Terminal No.	1	Color of Wire	O	Signal Name [Specification]				
Connector No.	E8															
Connector Name	WIRE TO WIRE															
Connector Type	M02AW-LC															
Terminal No.	1															
Color of Wire	O															
Signal Name [Specification]																
<table border="1"> <tr> <td>Connector No.</td> <td>E10</td> </tr> <tr> <td>Connector Name</td> <td>IPDM E/R (INTELLIGENT POWER DISTRIBUTION MODULE ENGINE ROOM)</td> </tr> <tr> <td>Connector Type</td> <td>M06FW-LC</td> </tr> </table>  	Connector No.	E10	Connector Name	IPDM E/R (INTELLIGENT POWER DISTRIBUTION MODULE ENGINE ROOM)	Connector Type	M06FW-LC	<table border="1"> <tr> <td>Terminal No.</td> <td>3</td> <td>5</td> </tr> <tr> <td>Color of Wire</td> <td>O</td> <td>R</td> </tr> <tr> <td>Signal Name [Specification]</td> <td></td> <td></td> </tr> </table>	Terminal No.	3	5	Color of Wire	O	R	Signal Name [Specification]		
Connector No.	E10															
Connector Name	IPDM E/R (INTELLIGENT POWER DISTRIBUTION MODULE ENGINE ROOM)															
Connector Type	M06FW-LC															
Terminal No.	3	5														
Color of Wire	O	R														
Signal Name [Specification]																
<table border="1"> <tr> <td>Connector No.</td> <td>E11</td> </tr> <tr> <td>Connector Name</td> <td>IPDM E/R (INTELLIGENT POWER DISTRIBUTION MODULE ENGINE ROOM)</td> </tr> <tr> <td>Connector Type</td> <td>M06FB-LC</td> </tr> </table>  	Connector No.	E11	Connector Name	IPDM E/R (INTELLIGENT POWER DISTRIBUTION MODULE ENGINE ROOM)	Connector Type	M06FB-LC	<table border="1"> <tr> <td>Terminal No.</td> <td>11</td> </tr> <tr> <td>Color of Wire</td> <td>B</td> </tr> <tr> <td>Signal Name [Specification]</td> <td></td> </tr> </table>	Terminal No.	11	Color of Wire	B	Signal Name [Specification]				
Connector No.	E11															
Connector Name	IPDM E/R (INTELLIGENT POWER DISTRIBUTION MODULE ENGINE ROOM)															
Connector Type	M06FB-LC															
Terminal No.	11															
Color of Wire	B															
Signal Name [Specification]																
<table border="1"> <tr> <td>Connector No.</td> <td>E13</td> </tr> <tr> <td>Connector Name</td> <td>IPDM E/R (INTELLIGENT POWER DISTRIBUTION MODULE ENGINE ROOM)</td> </tr> <tr> <td>Connector Type</td> <td>TH12FW-NH</td> </tr> </table>  	Connector No.	E13	Connector Name	IPDM E/R (INTELLIGENT POWER DISTRIBUTION MODULE ENGINE ROOM)	Connector Type	TH12FW-NH	<table border="1"> <tr> <td>Terminal No.</td> <td>25</td> </tr> <tr> <td>Color of Wire</td> <td>B</td> </tr> <tr> <td>Signal Name [Specification]</td> <td></td> </tr> </table>	Terminal No.	25	Color of Wire	B	Signal Name [Specification]				
Connector No.	E13															
Connector Name	IPDM E/R (INTELLIGENT POWER DISTRIBUTION MODULE ENGINE ROOM)															
Connector Type	TH12FW-NH															
Terminal No.	25															
Color of Wire	B															
Signal Name [Specification]																
<table border="1"> <tr> <td>Connector No.</td> <td>E14</td> </tr> <tr> <td>Connector Name</td> <td>IPDM E/R (INTELLIGENT POWER DISTRIBUTION MODULE ENGINE ROOM)</td> </tr> <tr> <td>Connector Type</td> <td>NS12FBR-CS</td> </tr> </table>  	Connector No.	E14	Connector Name	IPDM E/R (INTELLIGENT POWER DISTRIBUTION MODULE ENGINE ROOM)	Connector Type	NS12FBR-CS	<table border="1"> <tr> <td>Terminal No.</td> <td>45</td> </tr> <tr> <td>Color of Wire</td> <td>Y</td> </tr> <tr> <td>Signal Name [Specification]</td> <td></td> </tr> </table>	Terminal No.	45	Color of Wire	Y	Signal Name [Specification]				
Connector No.	E14															
Connector Name	IPDM E/R (INTELLIGENT POWER DISTRIBUTION MODULE ENGINE ROOM)															
Connector Type	NS12FBR-CS															
Terminal No.	45															
Color of Wire	Y															
Signal Name [Specification]																
<table border="1"> <tr> <td>Connector No.</td> <td>E15</td> </tr> <tr> <td>Connector Name</td> <td>IPDM E/R (INTELLIGENT POWER DISTRIBUTION MODULE ENGINE ROOM)</td> </tr> <tr> <td>Connector Type</td> <td>NS18FW-CS</td> </tr> </table>  	Connector No.	E15	Connector Name	IPDM E/R (INTELLIGENT POWER DISTRIBUTION MODULE ENGINE ROOM)	Connector Type	NS18FW-CS	<table border="1"> <tr> <td>Terminal No.</td> <td>58</td> </tr> <tr> <td>Color of Wire</td> <td>LG</td> </tr> <tr> <td>Signal Name [Specification]</td> <td></td> </tr> </table>	Terminal No.	58	Color of Wire	LG	Signal Name [Specification]				
Connector No.	E15															
Connector Name	IPDM E/R (INTELLIGENT POWER DISTRIBUTION MODULE ENGINE ROOM)															
Connector Type	NS18FW-CS															
Terminal No.	58															
Color of Wire	LG															
Signal Name [Specification]																
<table border="1"> <tr> <td>Connector No.</td> <td>E105</td> </tr> <tr> <td>Connector Name</td> <td>WIRE TO WIRE</td> </tr> <tr> <td>Connector Type</td> <td>TH8DFW-CS16-TM4</td> </tr> </table>  	Connector No.	E105	Connector Name	WIRE TO WIRE	Connector Type	TH8DFW-CS16-TM4	<table border="1"> <tr> <td>Terminal No.</td> <td>10</td> <td>91</td> </tr> <tr> <td>Color of Wire</td> <td>L</td> <td>R</td> </tr> <tr> <td>Signal Name [Specification]</td> <td></td> <td></td> </tr> </table>	Terminal No.	10	91	Color of Wire	L	R	Signal Name [Specification]		
Connector No.	E105															
Connector Name	WIRE TO WIRE															
Connector Type	TH8DFW-CS16-TM4															
Terminal No.	10	91														
Color of Wire	L	R														
Signal Name [Specification]																

JCBWM0971G1

# STARTING SYSTEM

## < COMPONENT DIAGNOSIS >

### STARTING SYSTEM

Connector No.	F21	Connector No.	F49	Connector No.	F47	Connector No.	F123
Connector Name	PARK / NEUTRAL POSITION SWITCH	Connector Name	STARTER MOTOR	Connector Name	STARTER MOTOR	Connector Name	WIRE TO WIRE
Connector Type	RK0BFG	Connector Type	-	Connector Type	X01MGY	Connector Type	M02FW-LC
							
							
Terminal No.	1	Terminal No.	2	Terminal No.	1	Terminal No.	1
Color of Wire	LG	Color of Wire	B/R	Color of Wire	O	Color of Wire	O
Signal Name [Specification]	-	Signal Name [Specification]	-	Signal Name [Specification]	-	Signal Name [Specification]	-

JCBWM0972G1

A  
STR  
C  
D  
E  
F  
G  
H  
I  
J  
K  
L  
M  
N  
O  
P

# STARTING SYSTEM

< SYMPTOM DIAGNOSIS >

## SYMPTOM DIAGNOSIS

### STARTING SYSTEM

#### Symptom Table

INFOID:000000004233763

Symptom	Reference
No normal cranking	Refer to <a href="#">STR-2, "Work Flow"</a> .
Starter motor does not rotate	

# PRECAUTIONS

< PRECAUTION >

## PRECAUTION

### PRECAUTIONS

#### FOR USA AND CANADA

#### FOR USA AND CANADA : Precaution for Supplemental Restraint System (SRS) "AIR BAG" and "SEAT BELT PRE-TENSIONER"

INFOID:000000004678861

The Supplemental Restraint System such as "AIR BAG" and "SEAT BELT PRE-TENSIONER", used along with a front seat belt, helps to reduce the risk or severity of injury to the driver and front passenger for certain types of collision. This system includes seat belt switch inputs and dual stage front air bag modules. The SRS system uses the seat belt switches to determine the front air bag deployment, and may only deploy one front air bag, depending on the severity of a collision and whether the front occupants are belted or unbelted. Information necessary to service the system safely is included in the "SRS AIRBAG" and "SEAT BELT" of this Service Manual.

#### **WARNING:**

- To avoid rendering the SRS inoperative, which could increase the risk of personal injury or death in the event of a collision which would result in air bag inflation, all maintenance must be performed by an authorized NISSAN/INFINITI dealer.
- Improper maintenance, including incorrect removal and installation of the SRS, can lead to personal injury caused by unintentional activation of the system. For removal of Spiral Cable and Air Bag Module, see the "SRS AIRBAG".
- Never use electrical test equipment on any circuit related to the SRS unless instructed to in this Service Manual. SRS wiring harnesses can be identified by yellow and/or orange harnesses or harness connectors.

#### FOR MEXICO

#### FOR MEXICO : Precaution for Supplemental Restraint System (SRS) "AIR BAG" and "SEAT BELT PRE-TENSIONER"

INFOID:000000004678862

The Supplemental Restraint System such as "AIR BAG" and "SEAT BELT PRE-TENSIONER", used along with a front seat belt, helps to reduce the risk or severity of injury to the driver and front passenger for certain types of collision. Information necessary to service the system safely is included in the "SRS AIRBAG" and "SEAT BELT" of this Service Manual.

#### **WARNING:**

- To avoid rendering the SRS inoperative, which could increase the risk of personal injury or death in the event of a collision which would result in air bag inflation, all maintenance must be performed by an authorized NISSAN/INFINITI dealer.
- Improper maintenance, including incorrect removal and installation of the SRS, can lead to personal injury caused by unintentional activation of the system. For removal of Spiral Cable and Air Bag Module, see the "SRS AIRBAG".
- Do not use electrical test equipment on any circuit related to the SRS unless instructed to in this Service Manual. SRS wiring harnesses can be identified by yellow and/or orange harnesses or harness connectors.

A

STR

C

D

E

F

G

H

I

J

K

L

M

N

O

P

# PREPARATION

< PREPARATION >

## PREPARATION

### PREPARATION

#### Special Service Tools

INFOID:000000004233766

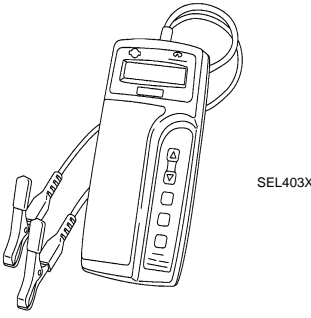
Tool number (Kent-Moore No.) Tool name	Description
<p>— (J-44373 Model MCR620) Starting/Charging System Tester</p>  <p>SEL403X</p>	<p>Tests starting and charging systems. For operating instructions, refer to Technical Service Bulletin.</p>

#### Commercial Service Tools

INFOID:000000004233767

Tool name	Description
<p>Power tool</p>  <p>PIIB1407E</p>	<p>Loosening bolts, nuts and screws</p>

# STARTER MOTOR

< ON-VEHICLE REPAIR >

## ON-VEHICLE REPAIR

### STARTER MOTOR

2WD

2WD : Exploded View

INFOID:000000004233768

#### REMOVAL

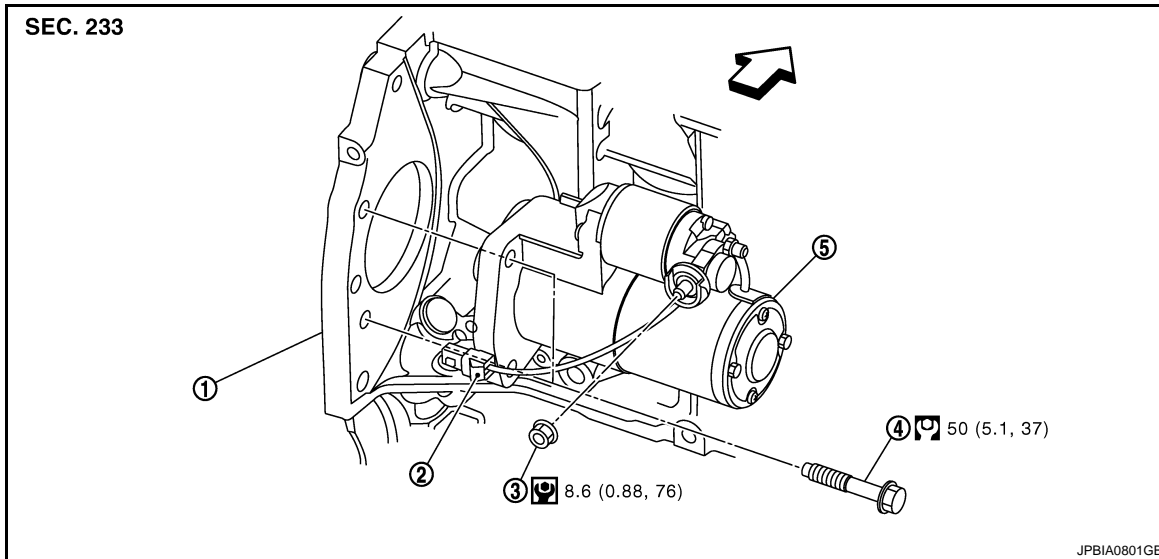

1. Cylinder block
2. "S" connector
3. "B" terminal nut
4. Starter motor mounting bolt
5. Starter motor

⇐ : Vehicle front

Refer to [GI-4, "Components"](#) for symbols in the figure.

#### DISASSEMBLY

Type: M000TA0271

# STARTER MOTOR

< ON-VEHICLE REPAIR >

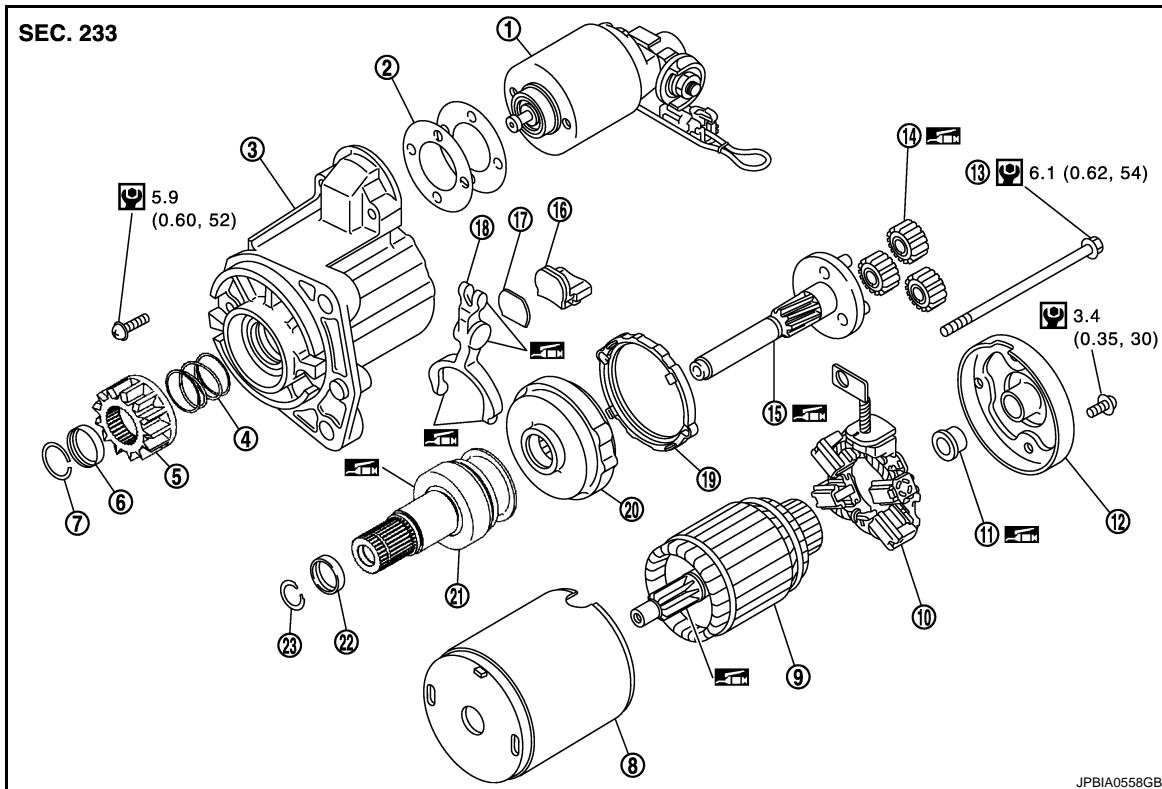

- |                             |                    |                         |
|-----------------------------|--------------------|-------------------------|
| 1. Magnetic switch assembly | 2. Adjusting plate | 3. Gear case            |
| 4. Spring                   | 5. Pinion          | 6. Pinion stopper       |
| 7. Stopper ring             | 8. Yoke            | 9. Armature             |
| 10. Brush holder assembly   | 11. Metal RR       | 12. Rear cover          |
| 13. Through bolt            | 14. Planetary gear | 15. Gear shaft          |
| 16. Packing                 | 17. Plate          | 18. Shift lever         |
| 19. Packing                 | 20. Internal gear  | 21. Over running clutch |
| 22. Retainer ring           | 23. Snap ring      |                         |

 : High-temperature grease point

Refer to [GI-4, "Components"](#) for symbols not described on the above.

## 2WD : Removal and Installation

INFOID:000000004233769

### REMOVAL

1. Disconnect the battery cable from the negative terminal.
2. Remove "B" terminal nut (A) and "B" terminal harness.

 : Vehicle front

3. Disconnect "S" connector (B).
4. Remove starter motor mounting bolts (C), using power tools.

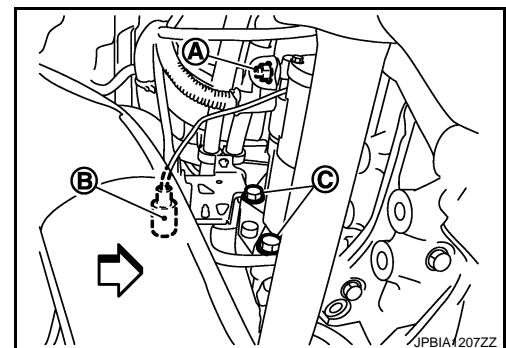

5. Remove starter motor downward from the vehicle.

### INSTALLATION



# STARTER MOTOR

## < ON-VEHICLE REPAIR >

Install in the reverse order of removal.

### CAUTION:

Be sure to tighten "B" terminal nut carefully.

2WD : Inspection

INFOID:000000004233770

A

STR

## INSPECTION AFTER DISASSEMBLY

### Pinion/Clutch Check

1. Inspect pinion teeth.
  - Replace pinion if teeth are worn or damaged. (Also check condition of ring gear teeth.)
2. Inspect reduction gear teeth.
  - Replace reduction gear if teeth are worn or damaged. (Also check condition of armature shaft gear teeth.)
3. Check to see if pinion locks in one direction and rotates smoothly in the opposite direction.
  - If it locks or rotates in both directions, or unusual resistance is evident, replace.

C

D

E

## AWD

AWD : Exploded View

INFOID:000000004233771

F

## REMOVAL

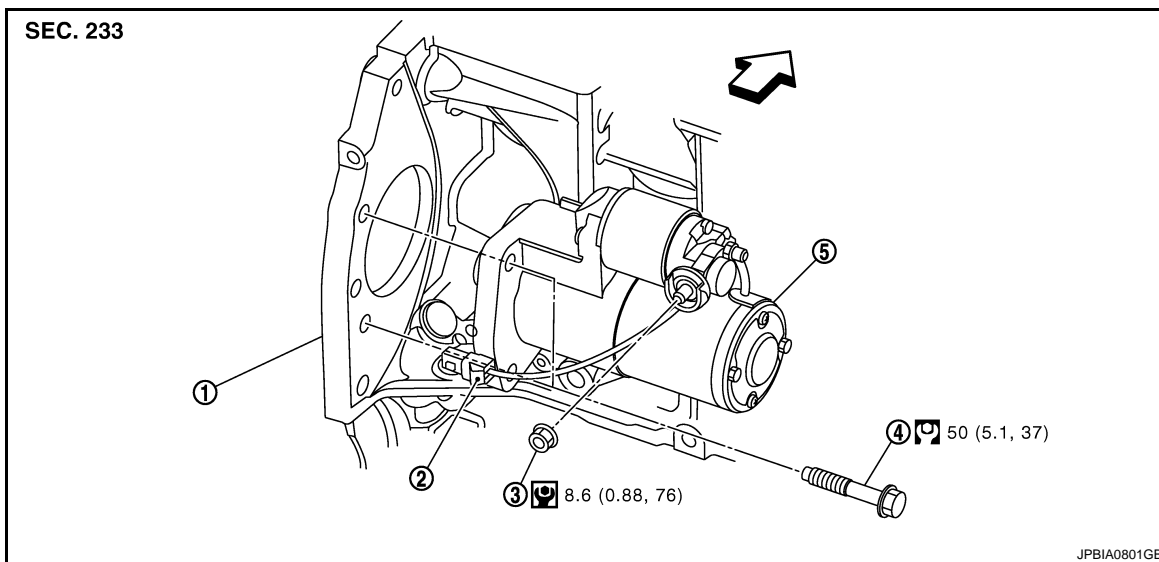

G

H

I

J

K

L

- |                                |                  |                     |
|--------------------------------|------------------|---------------------|
| 1. Cylinder block              | 2. "S" connector | 3. "B" terminal nut |
| 4. Starter motor mounting bolt | 5. Starter motor |                     |

M

⇐ : Vehicle front

Refer to [GI-4, "Components"](#) for symbols in the figure.

N

## DISASSEMBLY

Type: M000TA0271

O

P

# STARTER MOTOR

< ON-VEHICLE REPAIR >

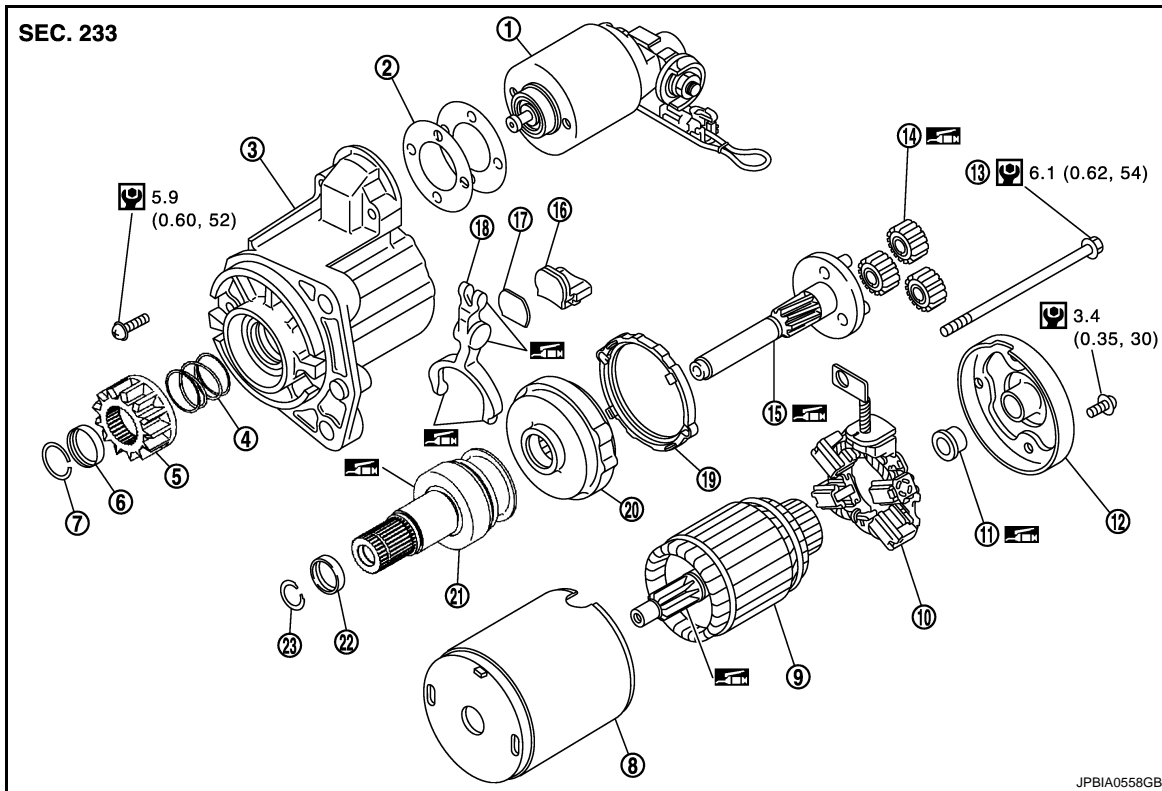

- |                             |                    |                         |
|-----------------------------|--------------------|-------------------------|
| 1. Magnetic switch assembly | 2. Adjusting plate | 3. Gear case            |
| 4. Spring                   | 5. Pinion          | 6. Pinion stopper       |
| 7. Stopper ring             | 8. Yoke            | 9. Armature             |
| 10. Brush holder assembly   | 11. Metal RR       | 12. Rear cover          |
| 13. Through bolt            | 14. Planetary gear | 15. Gear shaft          |
| 16. Packing                 | 17. Plate          | 18. Shift lever         |
| 19. Packing                 | 20. Internal gear  | 21. Over running clutch |
| 22. Retainer ring           | 23. Snap ring      |                         |

 : High-temperature grease point

Refer to [GI-4, "Components"](#) for symbols not described on the above.

## AWD : Removal and Installation

INFOID:000000004233772

### REMOVAL

1. Disconnect the battery cable from the negative terminal.
2. Remove front wheel and tire (RH).
3. Remove "B" terminal nut (A) and "B" terminal harness.

 : Vehicle front

4. Disconnect "S" connector (B).
5. Remove starter motor mounting bolts (C), using power tools.

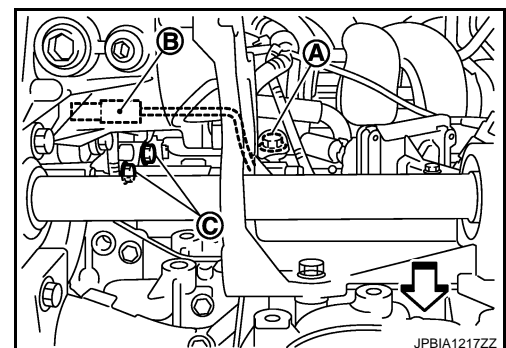

6. Slide the alternator out and remove.

# STARTER MOTOR

< ON-VEHICLE REPAIR >

## INSTALLATION

Install in the reverse order of removal.

### **CAUTION:**

**Be sure to tighten "B" terminal nut carefully.**

AWD : Inspection

INFOID:000000004233773

STR

## INSPECTION AFTER DISASSEMBLY

Pinion/Clutch Check

1. Inspect pinion teeth.
  - Replace pinion if teeth are worn or damaged. (Also check condition of ring gear teeth.)
2. Inspect reduction gear teeth.
  - Replace reduction gear if teeth are worn or damaged. (Also check condition of armature shaft gear teeth.)
3. Check to see if pinion locks in one direction and rotates smoothly in the opposite direction.
  - If it locks or rotates in both directions, or unusual resistance is evident, replace.

A

C

D

E

F

G

H

I

J

K

L

M

N

O

P

## SERVICE DATA AND SPECIFICATIONS (SDS)

< SERVICE DATA AND SPECIFICATIONS (SDS)

# SERVICE DATA AND SPECIFICATIONS (SDS)

## SERVICE DATA AND SPECIFICATIONS (SDS)

### Starter Motor

INFOID:000000004233774

Applied model		QR25DE
Type		M000TA0271
Type		MITSUBISHI make
Type		Reduction gear type
System voltage [V]		12
No-load	Terminal voltage [V]	11
	Current [A]	Less than 90
	Revolution [rpm]	More than 2,400
Minimum diameter of commutator [mm (in)]		28.8 (1.134)
Minimum length of brush [mm (in)]		5.5 (0.217)
Brush spring tension [N (kg, lb)]		15.0 - 20.4 (1.53 - 2.08, 3.4 - 4.6)
Clearance between bearing metal and armature shaft [mm (in)]		Less than 0.2 (0.008)
Movement in height of pinion assembly [mm (in)]		0.5 - 2.0 (0.020 - 0.079)