

# HEATER AND AIR CONDITIONING

## SECTION HA

### CONTENTS

<b>PRECAUTIONS AND PREPARATION</b> .....	2	Main Power Supply and Ground Circuit Check....	40
Precautions for Supplemental Restraint System (SRS) "AIR BAG" .....	2	Power Supply Circuit Check For A/C System .....	40
Precautions for Working with HFC-134a (R-134a) .....	2	Thermo Control Amp. Check.....	40
Special Service Tools.....	6	Diagnostic Procedure 1 .....	41
R-134a Service Tools and Equipment .....	7	SYMPTOM: Blower motor does not rotate.....	41
Precautions for Service Equipment .....	9	Diagnostic Procedure 2 .....	43
<b>DESCRIPTION</b> .....	11	SYMPTOM: Intake door does not operate.....	43
Refrigeration Cycle .....	11	Diagnostic Procedure 3 .....	44
Component Layout.....	12	SYMPTOM: Magnet clutch does not engage when A/C switch and fan switch are ON. ....	44
Discharge Air Flow.....	13	Electrical Components Inspection .....	48
Control Operation.....	14	Fan Switch.....	48
<b>TROUBLE DIAGNOSES</b> .....	15	Blower Motor .....	48
How to Perform Trouble Diagnoses for Quick and Accurate Repair .....	15	Blower Resistor .....	48
Operational Check .....	16	A/C Switch .....	48
Symptom Chart .....	18	RECIRC Switch .....	48
Diagnostic Table .....	18	Thermal Protector.....	49
Preliminary Check.....	20	Thermo Control Amp. ....	49
Preliminary Check 1 .....	20	A/C Relay .....	49
Preliminary Check 2 .....	21	Dual-Pressure Switch .....	49
Preliminary Check 3 .....	22	Control Linkage Adjustment.....	49
Preliminary Check 4 .....	23	Mode Control Cable .....	49
Performance Test Diagnoses.....	24	Water Cock Control Rod .....	50
Insufficient Cooling .....	24	Temperature Control Cable .....	50
Performance Chart.....	26	Intake Door Motor.....	50
Test Condition.....	26	System Description.....	50
Test Reading.....	26	Intake Door Motor.....	50
Trouble Diagnoses for Abnormal Pressure.....	27	<b>SERVICE PROCEDURES</b> .....	51
Harness Layout.....	31	Discharging Refrigerant.....	51
Engine Compartment.....	31	Evacuating System And Charging Refrigerant .....	51
Passenger Compartment.....	32	Compressor Lubricant Quantity .....	53
Circuit Diagram — Air Conditioner .....	33	Lubricant .....	53
GA Engine .....	33	Checking And Adjusting.....	53
SR Engine .....	34	Refrigerant Lines.....	55
Wiring Diagram —HEATER—.....	35	GA16DE Engine Model .....	55
Wiring Diagram —A/C—.....	36		

# CONTENTS (Cont'd.)

SR20DE Engine Model .....	56	Installation.....	62	GI
Compressor Mounting.....	57	Cooling Unit .....	62	
Belt Tension .....	57	Removal.....	62	
Fast Idle Control Device (FICD) .....	57	Installation.....	63	MA
Compressor.....	58	Control Assembly .....	63	
Compressor Clutch .....	58	<b>SERVICE DATA AND SPECIFICATIONS (SDS) .....</b>	<b>64</b>	
Removal.....	58	General Specifications .....	64	EM
Inspection .....	59	Compressor .....	64	
Installation.....	59	LUBRICANT .....	64	LC
Break-In Operation .....	60	Refrigerant.....	64	
Thermal Protector .....	60	Inspection and Adjustment.....	64	
Inspection .....	60	Engine Idle Speed .....	64	EC
Heater Unit.....	61	Belt Tension .....	64	
Removal.....	61	Compressor .....	64	FE

**When you read wiring diagrams:**

- Read GI section, "HOW TO READ WIRING DIAGRAMS".
- See EL section, "POWER SUPPLY ROUTING" for power distribution circuit.

When you perform trouble diagnoses, read GI section, "HOW TO FOLLOW FLOW CHART IN TROUBLE DIAGNOSES" and "HOW TO PERFORM EFFICIENT DIAGNOSIS FOR AN ELECTRICAL INCIDENT".

GI

MA

EM

LC

EC

FE

CL

MT

AT

FA

RA

BR

ST

RS

BT

**HA**

EL

IDX

## PRECAUTIONS AND PREPARATION

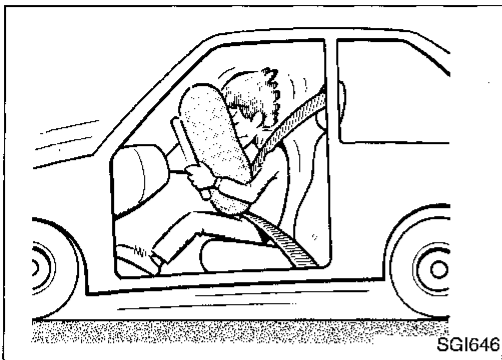

### Precautions for Supplemental Restraint System (SRS) "AIR BAG"

The Supplemental Restraint System "Air Bag", used along with a seat belt, helps to reduce the risk or severity of injury to the driver and front passenger in a frontal collision. The Supplemental Restraint System consists of air bag modules (located in the center of the steering wheel and on the instrument panel on the passenger side), a diagnosis sensor unit, warning lamp, wiring harness and spiral cable. Information necessary to service the system safely is included in the **RS section** of this Service Manual.

#### WARNING:

- To avoid rendering the SRS inoperative, which could increase the risk of personal injury or death in the event of a collision which would result in air bag inflation, all maintenance must be performed by an authorized NISSAN dealer.
- Improper maintenance, including incorrect removal and installation of the SRS, can lead to personal injury caused by unintentional activation of the system.
- All SRS electrical wiring harnesses and connectors are covered with yellow outer insulation. Do not use electrical test equipment on any circuit related to the SRS.

### Precautions for Working With HFC-134a (R-134a)

#### WARNING:

- CFC-12 (R-12) refrigerant and HFC-134a (R-134a) refrigerant are not compatible. These refrigerants must never be mixed, even in the smallest amounts. If the refrigerants are mixed, compressor malfunction is likely.
- Use only specified lubricant for the HFC-134a (R-134a) A/C system and HFC-134a (R-134a) components. If lubricant other than that specified is used, compressor malfunction is likely.
- The specified HFC-134a (R-134a) lubricant rapidly absorbs moisture from the atmosphere. The following handling precautions must be observed:
  - a. When removing refrigerant components from a vehicle, immediately cap (seal) the component to minimize the entry of moisture from the atmosphere.
  - b. When installing refrigerant components to a vehicle, do not remove the caps (unseal) until just before connecting the components. Connect all refrigerant loop components as quickly as possible to minimize the entry of moisture into the system.
  - c. Only use the specified lubricant from a sealed container. Immediately reseal containers of lubricant. Without proper sealing, lubricant will become moisture saturated and should not be used.
  - d. Avoid breathing A/C refrigerant and lubricant vapor or mist. Exposure may irritate eyes, nose and throat. Remove HFC-134a (R-134a) from the A/C system using certified service equipment meeting requirements of SAE J2210 (R-134a recycling equipment) or J2209 (R-134a recovery equipment). If accidental system discharge occurs, ventilate work area before resuming service. Additional health and safety information may be obtained from refrigerant and lubricant manufacturers.
  - e. Do not allow lubricant to contact styrofoam parts. Damage may result.

# PRECAUTIONS AND PREPARATION

---

## Precautions for Working with Refrigerants

### WARNING:

- Do not release refrigerant into the air. Use approved recovery/recycling equipment to capture the refrigerant every time an air conditioning system is discharged.
- Always wear eye and hand protection (goggles and gloves) when working with any refrigerant or air conditioning system.
- Do not store or heat refrigerant containers above 52°C (125°F).
- Do not heat a refrigerant container with an open flame; if container warming is required, place the bottom of the container in a pail of warm water.
- Do not intentionally drop, puncture, or incinerate refrigerant containers.
- Keep refrigerant away from open flames: poisonous gas will be produced if refrigerant burns.
- Refrigerant will displace oxygen, therefore be certain to work in well ventilated areas to prevent suffocation.
- Do not introduce compressed air to any refrigerant container or refrigerant component.

GI  
MA  
EM  
LC  
EC  
FE  
CL  
MT  
AT  
FA  
RA  
BR  
ST  
RS  
BT  
HA  
EL  
IDX

# PRECAUTIONS AND PREPARATION

## Precautions for Refrigerant Connection

### WARNING:

Make sure all refrigerant is discharged into the recycling equipment and the pressure in the system is less than atmospheric pressure. Then gradually loosen the discharge side hose fitting and remove it.

### CAUTION:

When replacing or cleaning refrigerant cycle components, observe the following.

- Do not leave compressor on its side or upside down for more than 10 minutes. Compressor lubricant will enter low pressure chamber.
- When connecting tubes, always use a torque wrench and a back-up wrench.
- After disconnecting tubes, plug all openings immediately to prevent entry of dirt and moisture.
- When installing an air conditioning unit in the vehicle, connect the pipes as the final stage of the operation. Do not remove seal caps from pipes and other components until just before required for connection.
- Allow components stored in cool areas to warm to working area temperature before removing seal caps. This prevents condensation from forming inside A/C components.
- Thoroughly remove moisture from the refrigeration system before charging the refrigerant.
- Always replace used O-rings.
- When connecting tube, apply lubricant to portions shown in illustration. Be careful not to apply lubricant to threaded portion.

Name: Nissan A/C System Lubricant Type R

Part No.: KLH00-PAGR0

- O-ring must be closely attached to inflated portion of tube.
- After inserting tube into union until O-ring is no longer visible, tighten nut to specified torque.
- After connecting line, conduct leak test and make sure that there is no leakage. When the gas leaking point is found, disconnect that line and replace the O-ring. Then tighten connections of seal seat to the specified torque.

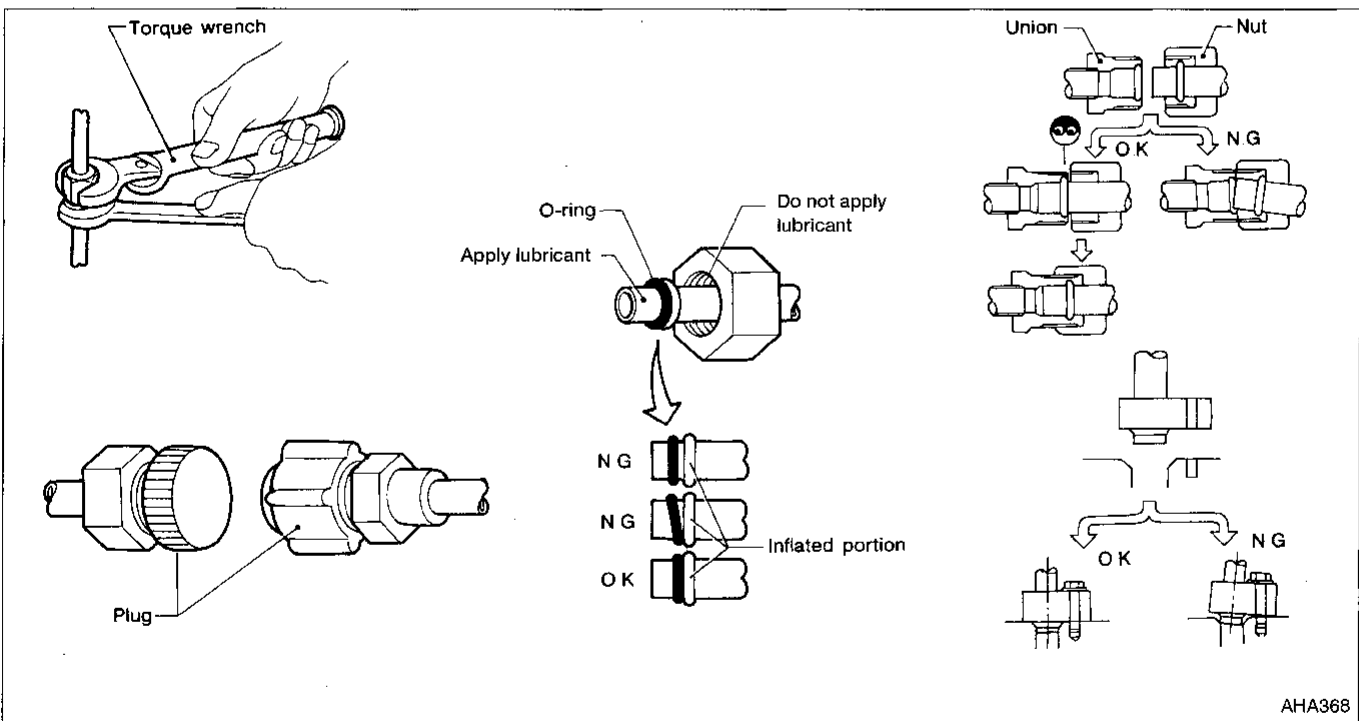

# PRECAUTIONS AND PREPARATION

---

## Precautions for Servicing Compressor

- Plug all openings to prevent moisture and foreign matter from entering.
- Do not keep the compressor in the upside down position or laid on its side for more than 10 minutes.
- When replacing or repairing compressor, be sure to remove lubricant from the compressor and check the lubricant quantity extracted.
- When replacing or repairing compressor, follow Lubricant - Checking and Adjusting procedure exactly. Refer to "Compressor Lubricant Quantity", "SERVICE PROCEDURES", HA-53.
- Keep friction surfaces between clutch and pulley clean. If the surface is contaminated with oil, wipe it off by using a clean waste cloth moistened with thinner.
- After compressor service operation, turn the compressor shaft by hand more than five turns in both directions. This will equally distribute lubricant inside the compressor. After the compressor is installed, let the engine idle and operate the compressor for one hour.
- After replacing the compressor magnet clutch, apply voltage to the new one and check for normal operation.

GI

MA

EM

LC

EC

FE

CL

MT

AT

FA

RA

BR

ST

RS

BT

**HA**

EL

IDX

# PRECAUTIONS AND PREPARATION

## Special Service Tools

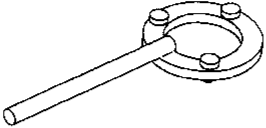
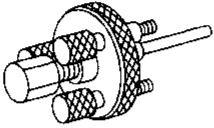
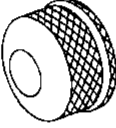
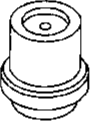
Tool number (Kent-Moore No.) Tool name	Description	Note
KV99231260 (J-38874) Clutch disc wrench	  NT204	Removing shaft nut and clutch disc
KV99232340 (J-38874) Clutch disc puller	  NT206	Removing clutch disc
KV99234330 (J-39024) Pulley installer	  NT207	Installing pulley
KV99233130 (J-39023) Pulley puller	  NT208	Removing pulley



# PRECAUTIONS AND PREPARATION

## R-134a Service Tools and Equipment

Never mix HFC-134a (R-134a) refrigerant and/or its specified lubricant with CFC-12 (R-12) refrigerant and/or its lubricant.

Separate and non-interchangeable service equipment must be used for each type of refrigerant/lubricant. Refrigerant container fittings, service hose fittings, and service equipment fittings (equipment which handles refrigerant and/or lubricant) are different between CFC-12 (R-12) and HFC-134a (R-134a). This is to avoid mixed use of the refrigerants/lubricants.

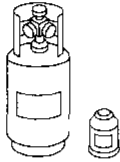
Adapters to convert from one size fitting to the other must never be used: refrigerant/lubricant contamination will occur and compressor failure will result.

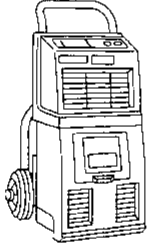
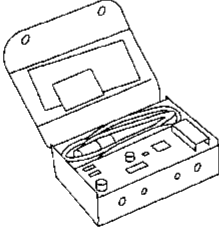

Tool number (Kent-Moore No.) Tool name	Description	Note
R-134a refrigerant	 NT196	Container color: Light blue Container marking: R-134a Fitting size: Thread size ● large container 1/2"-16 ACME
KLH00-PAGRO ( — ) Nissan A/C System Lubricant Type R	 NT197	Type: Poly alkylene glycol oil (PAG), type R Application: R-134a vane rotary compressors (Nissan only) Lubricity: 40 ml (1.4 US fl oz, 1.4 Imp fl oz)
(J-39500-NI) Recovery/Recycling equipment (ACR4)	 NT195	Function: Refrigerant Recovery and Recycling and Recharging
(J-39400) Electronic leak detector	 NT198	Power supply: ● DC 12 V (Cigarette lighter)

GI  
MA  
EM  
LC  
EC  
FE  
CL  
MT  
AT  
FA  
RA  
BR  
ST  
RS  
BT  
HA  
EL  
IDX

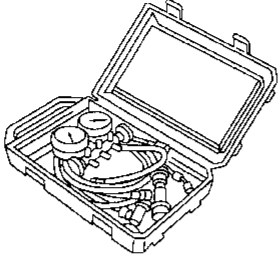
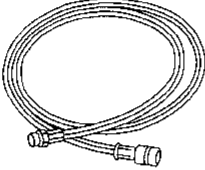
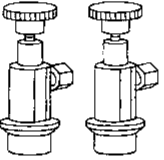

## PRECAUTIONS AND PREPARATION

### R-134a Service Tools and Equipment (Cont'd)

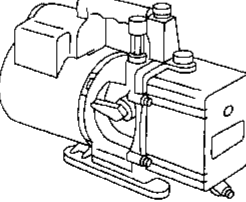
Tool number (Kent-Moore No.) Tool name	Description	Note
(J-39183) Manifold gauge set (with hoses and couplers)	 <p style="text-align: right;">NT199</p>	Identification: ● The gauge face indicates R-134a. Fitting size: Thread size ● 1/2"-16 ACME
Service hoses ● High side hose (J-39501-72) ● Low side hose (J-39502-72) ● Utility hose (J-39476-72)	 <p style="text-align: right;">NT201</p>	Hose color: ● Low hose: Blue with black stripe ● High hose: Red with black stripe ● Utility hose: Yellow with black stripe or green with black stripe Hose fitting to gauge: ● 1/2"-16 ACME
Service couplers ● High side coupler (J-39500-20) ● Low side coupler (J-39500-24)	 <p style="text-align: right;">NT202</p>	Hose fitting to service hose: ● M14 x 1.5 fitting (optional) or permanently attached
(J-39650) Refrigerant weight scale	 <p style="text-align: right;">NT200</p>	For measuring of refrigerant Fitting size: Thread size ● 1/2"-16 ACME
(J-39649) Vacuum pump (Including the isolator valve)	 <p style="text-align: right;">NT203</p>	Capacity: ● Air displacement: 4 CFM ● Micron rating: 20 microns ● Oil capacity: 482 g (17 oz) Fitting size: Thread size ● 1/2"-16 ACME

# PRECAUTIONS AND PREPARATION

## Precautions for Service Equipment

### RECOVERY/RECYCLING EQUIPMENT

Follow the manufacturer's instructions for machine operation and machine maintenance. Never introduce any refrigerant other than specified into the machine.

### ELECTRONIC LEAK DETECTOR

Follow the manufacturer's instructions for tester operation and tester maintenance.

### VACUUM PUMP

The lubricating oil contained inside the vacuum pump is not compatible with the specified lubricant for R-134a A/C systems. The vent side of the vacuum pump is exposed to atmospheric pressure. Therefore, if the pump is switched off after evacuation the lubricating oil may migrate into the hose. To prevent this, isolate the pump from the hose after evacuation (vacuuming). This migration is avoided by placing a manual valve near the hose-to-pump connection, as follows:

- Usually vacuum pumps have a manual isolator valve as part of the pump. Close this valve to isolate the service hose from the pump.
- For pumps without an isolator, use a hose equipped with a manual shut-off valve near pump end. Close the valve to isolate the hose from the pump.
- If the hose has an automatic shut-off valve, disconnect the hose from the pump. As long as the hose is connected, the valve is open and lubricating oil may migrate.

Some one-way valves open when vacuum is applied and close under a no vacuum condition. Such valves may restrict the pump's ability to pull a deep vacuum and are not recommended.

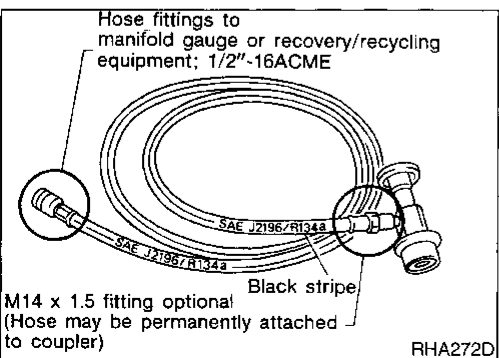
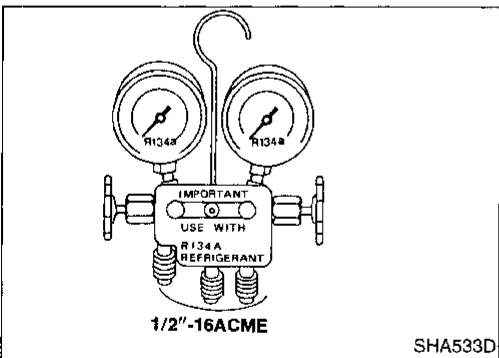
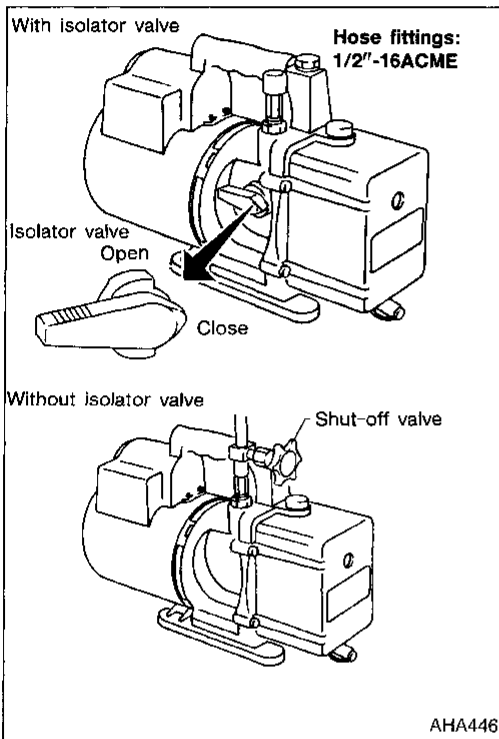

### MANIFOLD GAUGE SET

Be sure the gauge set has 1/2"-16 ACME threaded connections for service hoses. Confirm the set has been used only with refrigerant HFC-134a (R-134a) along with specified lubricants.

### SERVICE HOSES

Be certain that the service hoses display the markings described (colored hose with black stripe). Be certain all hoses include positive shut-off devices (either manual or automatic) near the service end opposite the manifold gauge.

CI

MA

EM

LC

EC

FE

CL

MT

AT

FA

RA

BR

ST

RS

BT

HA

EL

IDX

## PRECAUTIONS AND PREPARATION

### Precautions for Service Equipment (Cont'd)

#### SERVICE COUPLERS

Never attempt to connect R-134a service couplers to an CFC-12 (R-12) A/C system. The R-134a couplers will not properly connect to the CFC-12 (R-12) system. However, if an improper connection is attempted, discharging and contamination can occur.

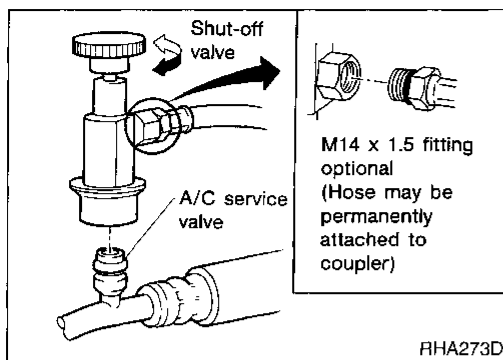

Shut off valve rotation	A/C service valve
Clockwise	Open
Counterclockwise	Close

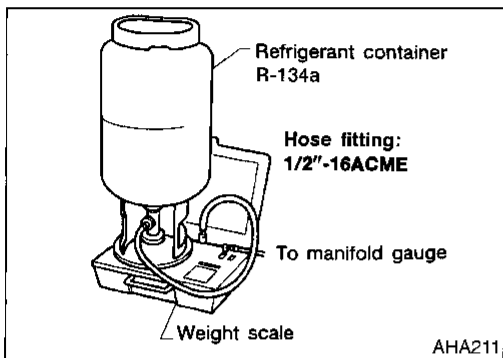

#### REFRIGERANT WEIGHT SCALE

When using a scale which controls refrigerant flow electronically, assure the following:

- Hose fitting size is 1/2"-16 ACME
- No refrigerant other than HFC-134a (R-134a) (along with specified lubricant) has been used with the scale

#### CHARGING CYLINDER

Using a charging cylinder is not recommended. Refrigerant may be vented into the air through the cylinder's top valve when filling the cylinder.

# DESCRIPTION

## Refrigeration Cycle

### REFRIGERANT FLOW

The refrigerant flow is in the standard pattern. Refrigerant flows through the compressor, condenser, liquid tank, evaporator and back to the compressor.

The refrigerant evaporation through the evaporator coil is controlled by an externally equalized expansion valve, located inside the evaporator case.

### FREEZE PROTECTION

The compressor cycles on and off to maintain the evaporator temperature within a specified range. When the evaporator coil temperature falls below a specified point, the thermo control amplifier interrupts the compressor operation. When the evaporator coil temperature rises above the specification, the thermo control amplifier allows compressor operation.

### REFRIGERANT SYSTEM PROTECTION

#### Dual-pressure switch

The dual-pressure switch is located on the liquid tank. If the system pressure rises or falls out of specifications, the switch opens to interrupt compressor clutch operation.

#### PRESSURE RELIEF VALVE

The refrigerant system is protected by a pressure relief valve. The valve is located on the compressor near the thermal protector. When refrigerant system pressure increases abnormally [over 3,727 kPa (38 kg/cm<sup>2</sup>, 540 psi)], the relief valve port opens. The valve then releases refrigerant into the atmosphere. The relief valve port closes when pressure reaches 2,991 kPa (30.5 kg/cm<sup>2</sup>, 434 psi).

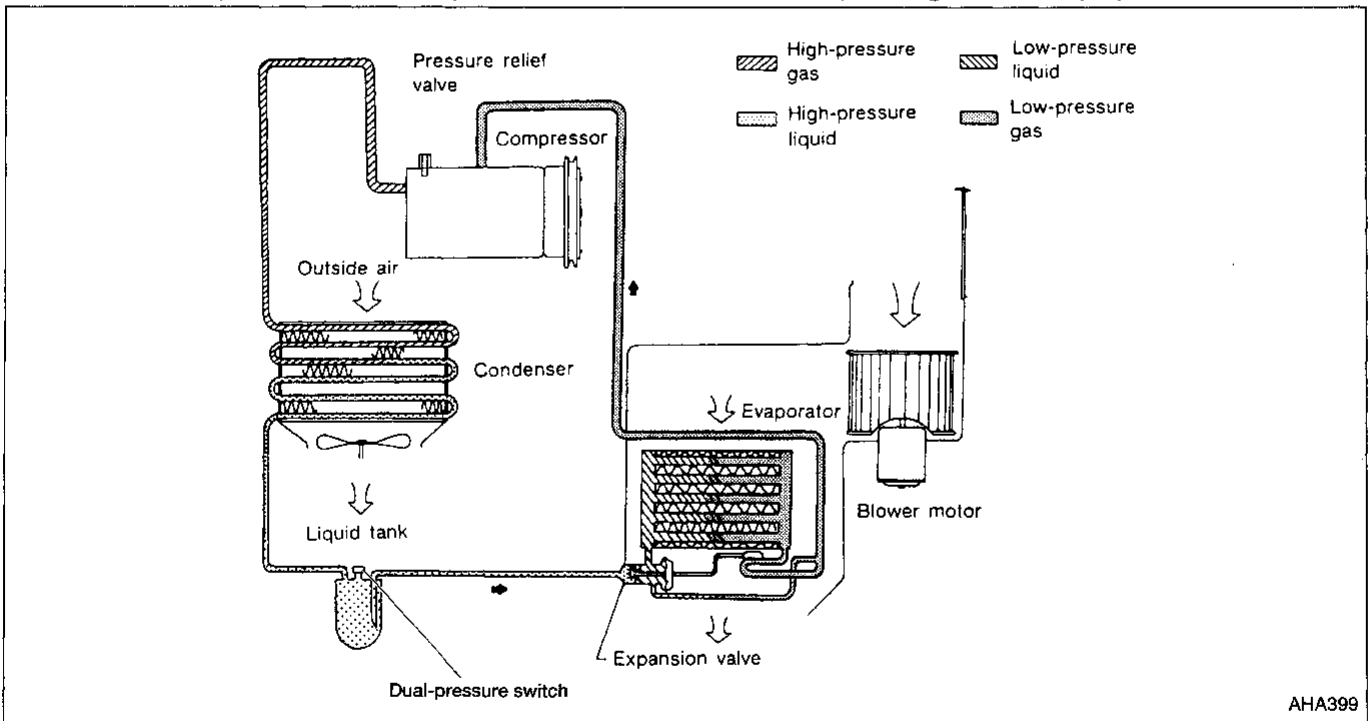

# DESCRIPTION

## Component Layout

SEC. 270-271-272-273-685

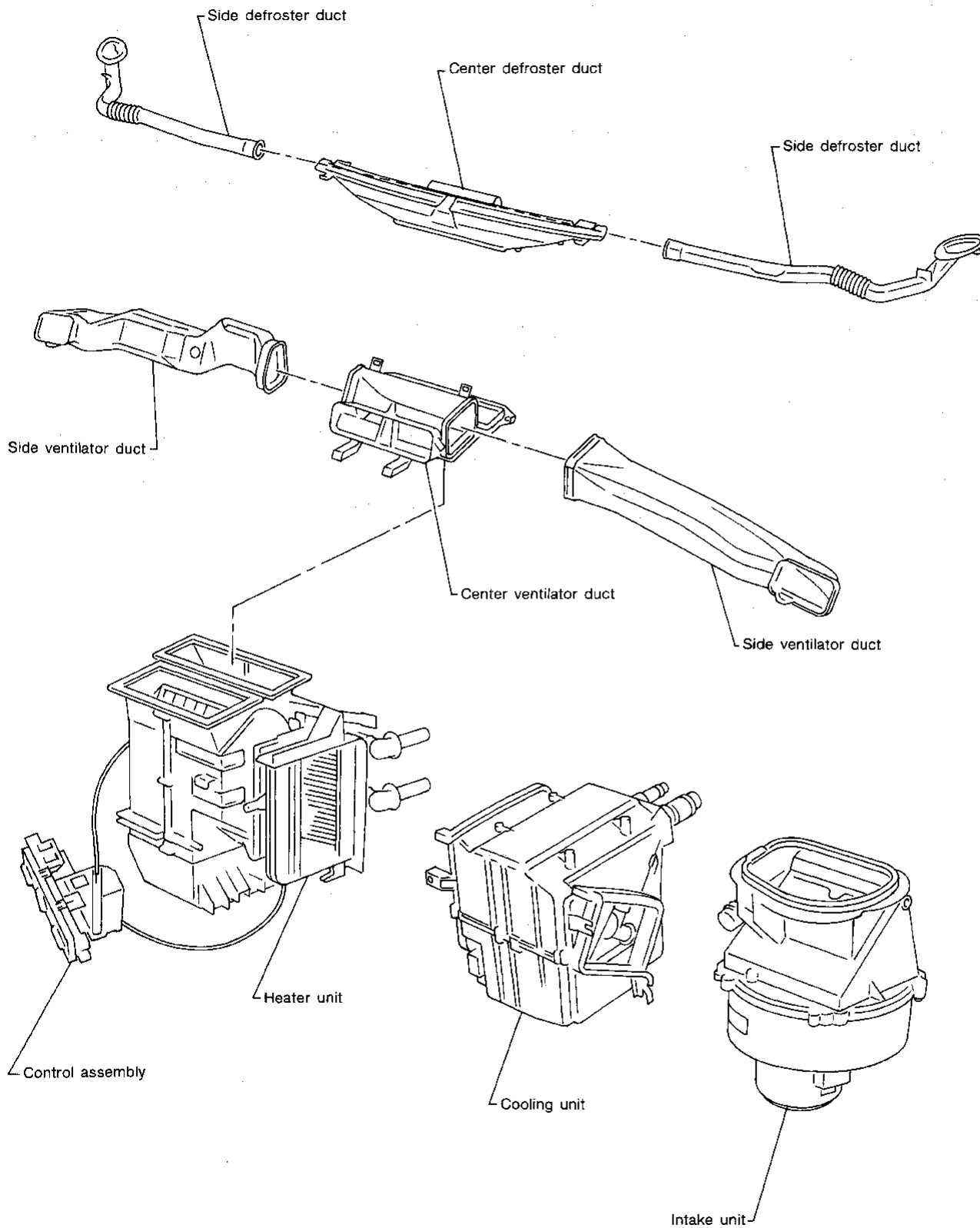

# DESCRIPTION

## Discharge Air Flow

**Air outlets**

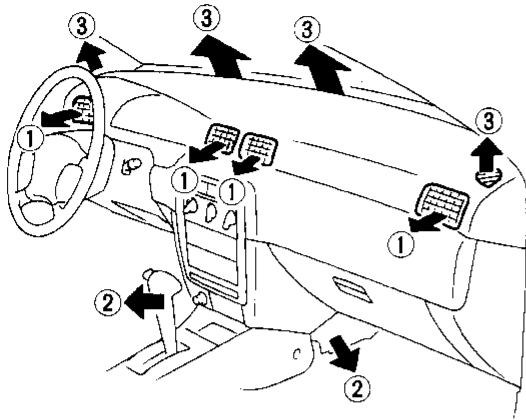

**Foot**

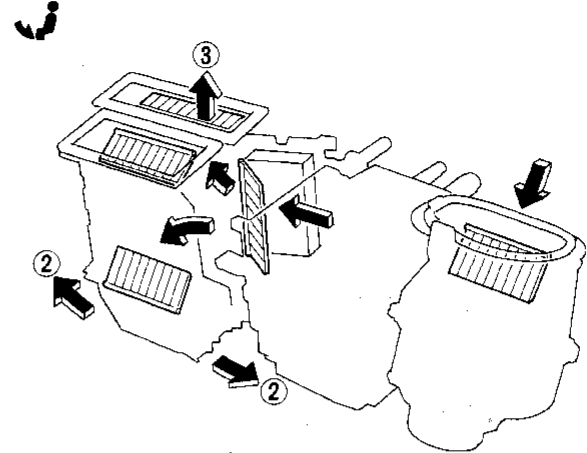

**Face**

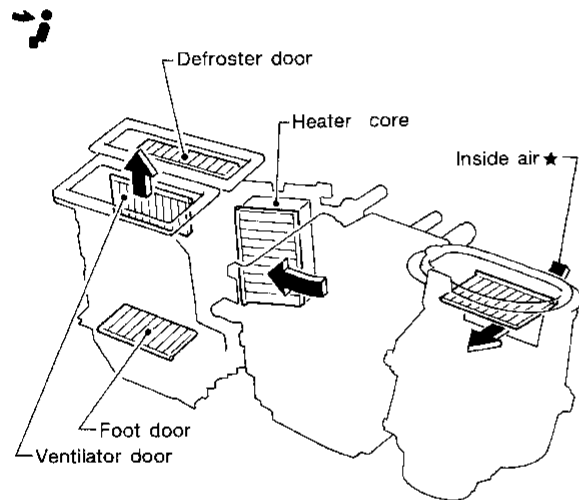

**Foot and defroster**

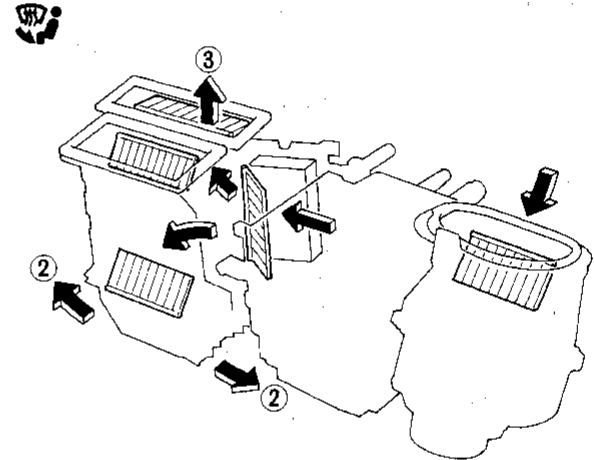

**Bi-level**

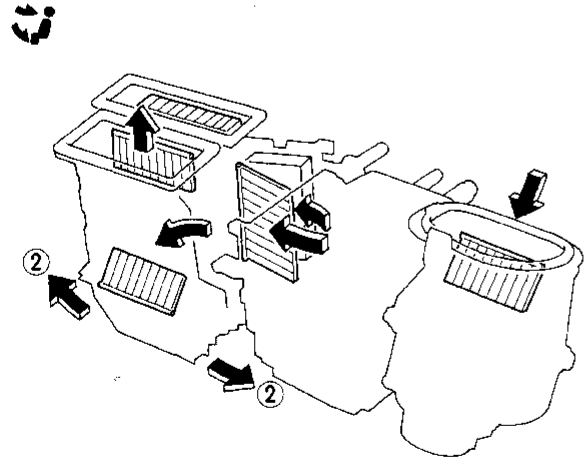

**Defroster**

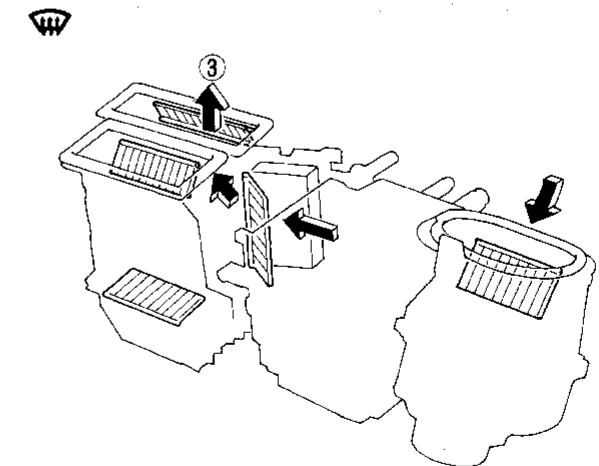

- ① : To face
- ② : To foot
- ③ : To defroster
- ★ : When RECIRC switch is ON

For air flow %, refer to "Operational Check", "TROUBLE DIAGNOSES".

GI  
MA  
EM  
LC  
EC  
FE  
CL  
MT  
AT  
FA  
RA  
BR  
ST  
RS  
BT  
HA  
EL  
IDX

# DESCRIPTION

## Control Operation

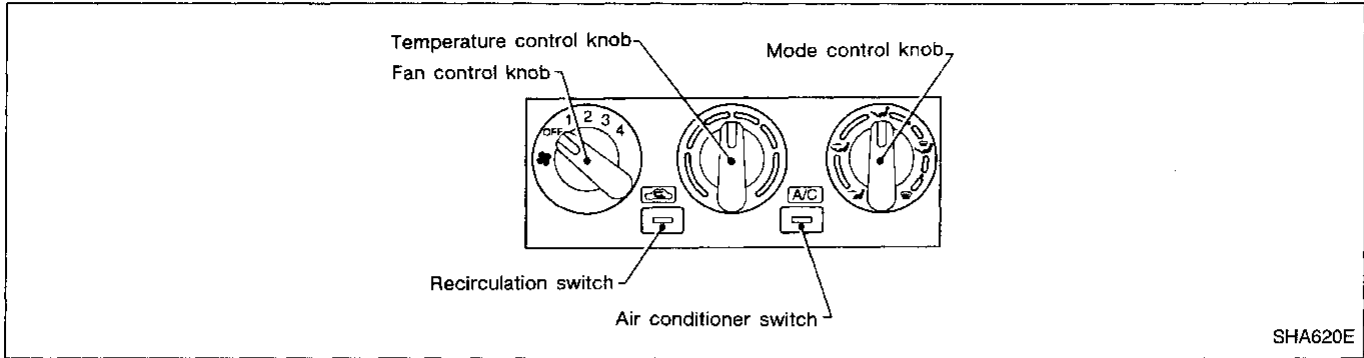

### FAN CONTROL KNOB

This knob turns the fan ON and OFF, and controls fan speed.

### MODE CONTROL KNOB

This knob controls the outlet air flow.

### TEMPERATURE CONTROL KNOB

This knob allows adjustment of the temperature of the outlet air.

### RECIRCULATION SWITCH

OFF position:

Outside air is drawn into the passenger compartment.

ON position:

Interior air is recirculated inside the vehicle.

The indicator lamp will also light.

Models without air conditioner do not have the recirculation switch. Outside air is always drawn into the passenger compartment when the fan is ON.

### AIR CONDITIONER SWITCH

The air conditioner switch controls the A/C system. When the switch is depressed with the fan ON, the compressor will turn ON. The indicator lamp will also light.

**The air conditioner cooling function operates only when the engine is running.**

# TROUBLE DIAGNOSES

## How to Perform Trouble Diagnoses for Quick and Accurate Repair

### WORK FLOW

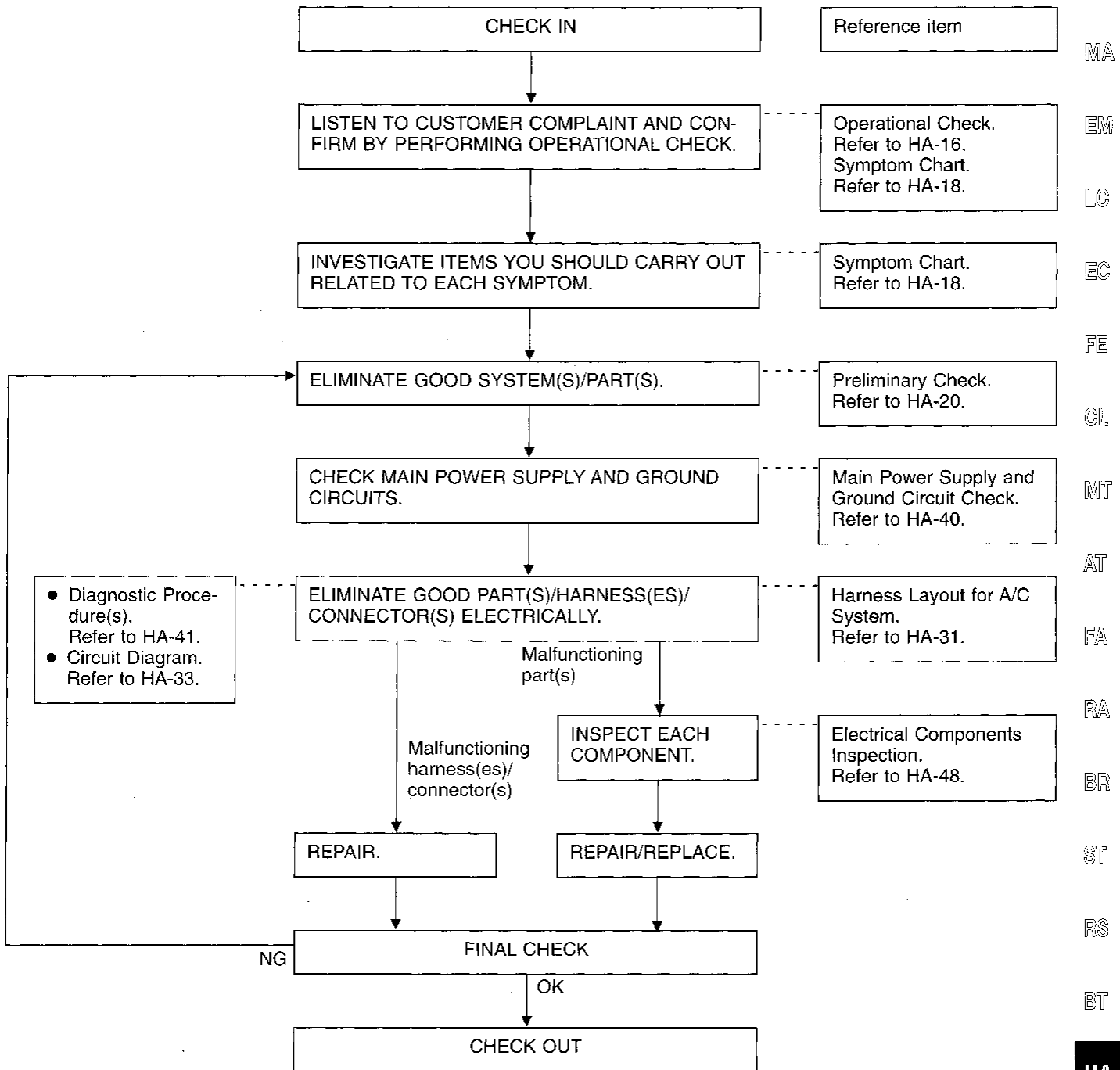

GI  
MA  
EM  
LC  
EC  
FE  
CL  
MT  
AT  
FA  
RA  
BR  
ST  
RS  
BT  
HA  
EL  
DX



# TROUBLE DIAGNOSES

## Operational Check

The purpose of the operational check is to confirm that the system operates properly.

### CONDITIONS:

- Engine running at normal operating temperature.

### PROCEDURE:

#### 1. Check blower

- Turn fan control knob to 1-speed. Blower should operate on 1-speed.
- Turn fan control knob to 2-speed, and continue checking blower speed until all speeds are checked.
- Leave blower on 4-speed.

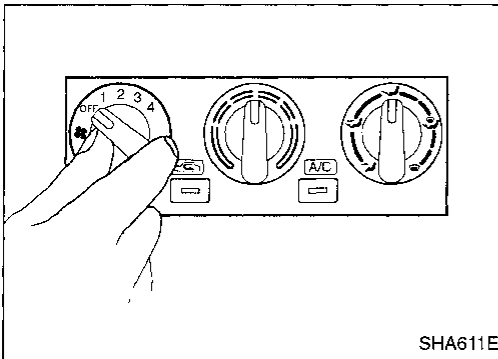

#### 2. Check discharge air

- Turn mode control knob.

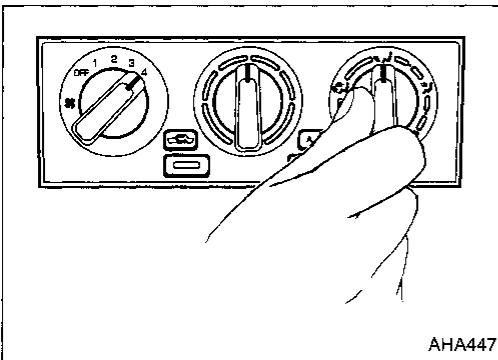





- Confirm that discharge air comes out according to the air distribution table at left.

Refer to "Discharge Air Flow", HA-13.

#### NOTE:

Confirm that the compressor clutch is engaged (visual inspection) when the DEF  mode is selected.

#### Discharge air flow

Switch mode/ indicator	Air outlet/distribution		
	Face	Foot	Defroster
	100%	—	—
	60%	40%	—
	—	80%	20%
	—	60%	40%
	—	—	100%

RHA376EA

## TROUBLE DIAGNOSES

### Operational Check (Cont'd)

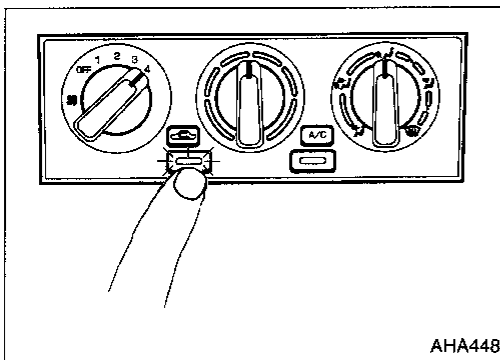

#### 3. Check RECIRCULATION

- Press recirculation switch.  
Recirculation indicator should light.
- Listen for intake door position change (you should hear blower sound change slightly).

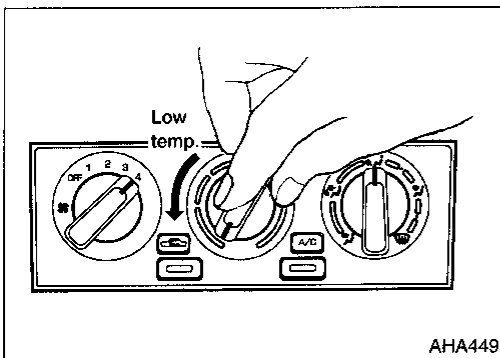

#### 4. Check temperature decrease

- Turn temperature control knob to full cold.
- Check for cold air at discharge air outlets.

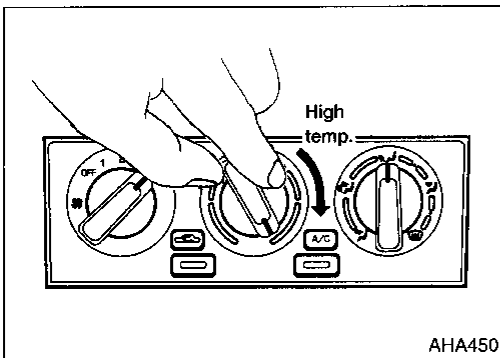

#### 5. Check temperature increase

- Turn temperature control knob to full hot.
- Check for hot air at discharge air outlets.

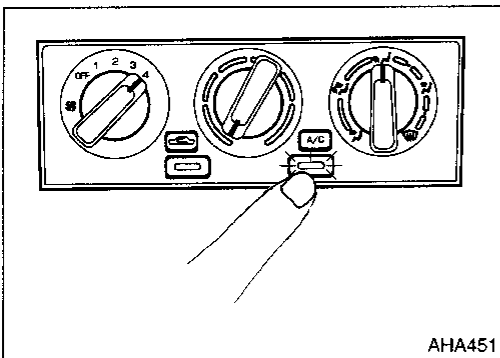

#### 6. Check air conditioner switch

Turn fan control knob to the desired (1- to 4-speed) position and push the A/C switch to turn ON the air conditioner. The indicator light should come on when air conditioner is ON.

CI

MA

EM

LC

EC

FE

CL

MT

AT

FA

RA

BR

ST

RS

BT

HA

EL

IDX

# TROUBLE DIAGNOSES

## Symptom Chart

### DIAGNOSTIC TABLE

PROCEDURE	Preliminary Check				Diagnostic Procedure			Main Power Supply and Ground Circuit Check			
	HA-20	HA-21	HA-22	HA-23	HA-41	HA-43	HA-44	HA-40	HA-40	HA-40	HA-40
REFERENCE PAGE	HA-20	HA-21	HA-22	HA-23	HA-41	HA-43	HA-44	HA-40	HA-40	HA-40	HA-40
SYMPTOM	Preliminary check 1	Preliminary check 2	Preliminary check 3	Preliminary check 4	Diagnostic procedure 1	Diagnostic procedure 2	Diagnostic procedure 3	15A Fuses	10A Fuse	7.5A fuses	Thermo control amp.
A/C does not blow cold air	①				○		○	○	○	○	○
Blower motor does not rotate	①				②			○			
Insufficient heating				①	○						
Air outlet does not change		①									
Intake door does not operate						①				○	
Magnet clutch does not operate when A/C switch and fan switch are ON	①						②		○	○	○
Noise			①								

①, ②: The number means checking order.  
 ○: Checking order depends on malfunction in each flow chart.

# TROUBLE DIAGNOSES

## Symptom Chart (Cont'd)

### Electrical Components Inspection

HA-48	Blower motor												
HA-48	Resistor	○	○	○	○	○	○	○	○	○	○	○	○
HA-48	A/C switch	○	○	○	○	○	○	○	○	○	○	○	○
—	REC switch	○	○	○	○	○	○	○	○	○	○	○	○
HA-48	Fan switch	○	○	○	○	○	○	○	○	○	○	○	○
HA-50	Intake door motor	○	○	○	○	○	○	○	○	○	○	○	○
HA-49	A/C relay	○	○	○	○	○	○	○	○	○	○	○	○
HA-49	Thermo control amp.	○	○	○	○	○	○	○	○	○	○	○	○
HA-49	Dual-pressure switch	○	○	○	○	○	○	○	○	○	○	○	○
HA-58	Compressor (Magnet clutch)	○	○	○	○	○	○	○	○	○	○	○	○
HA-60	Thermal protector	○	○	○	○	○	○	○	○	○	○	○	○
Refer to EC section	ECM (ECCS control module)	○	○	○	○	○	○	○	○	○	○	○	○
—	Harness	○	○	○	○	○	○	○	○	○	○	○	○

GI  
 MA  
 EM  
 LC  
 EC  
 FE  
 CL  
 MT  
 AT  
 FA  
 RA  
 BR  
 ST  
 RS  
 BT  
**HA**  
 EL  
 IDX

# TROUBLE DIAGNOSES

## Preliminary Check

### PRELIMINARY CHECK 1

A/C does not blow cold air

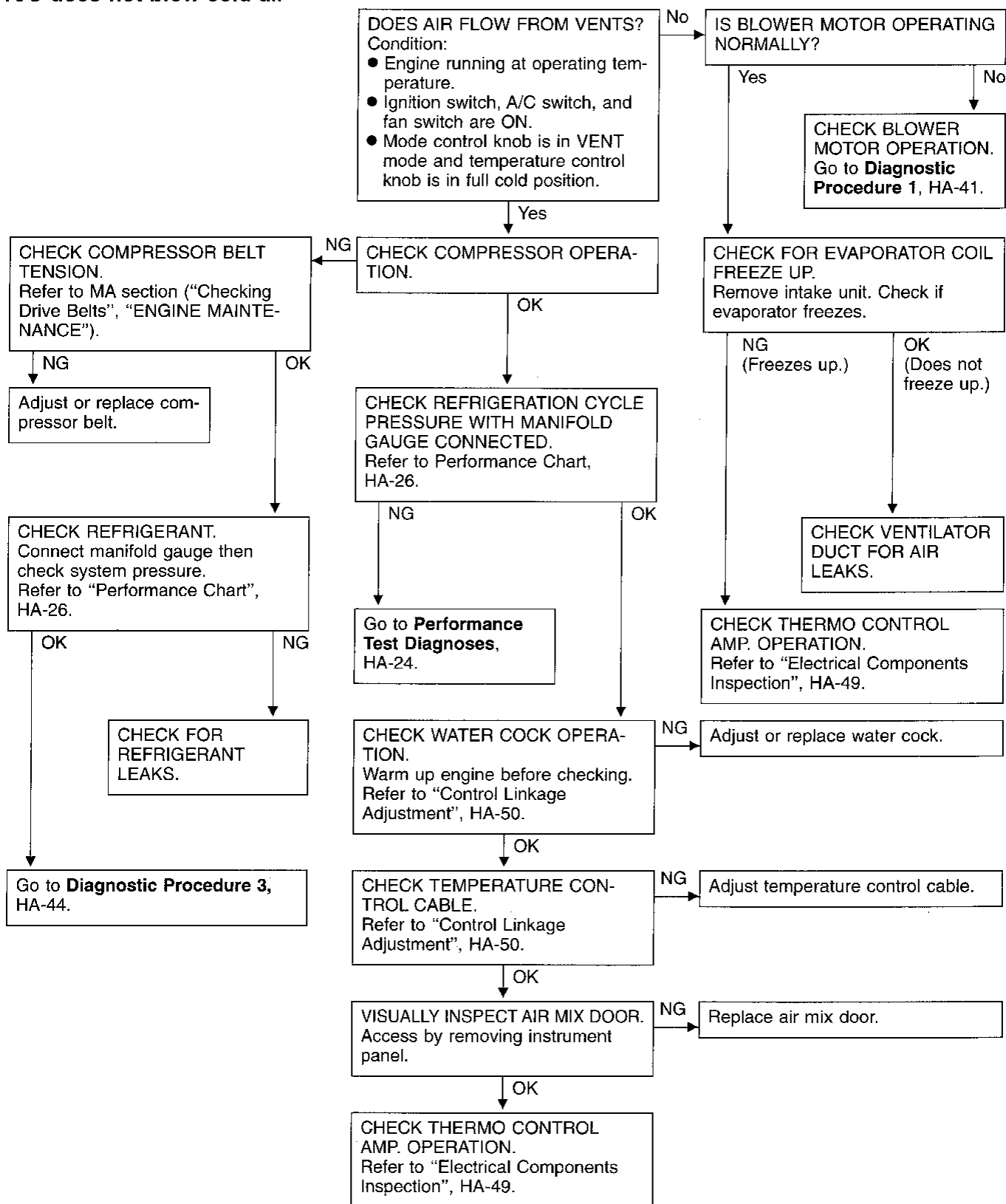

# TROUBLE DIAGNOSES

## Preliminary Check (Cont'd)

### PRELIMINARY CHECK 2

#### Air outlet does not change

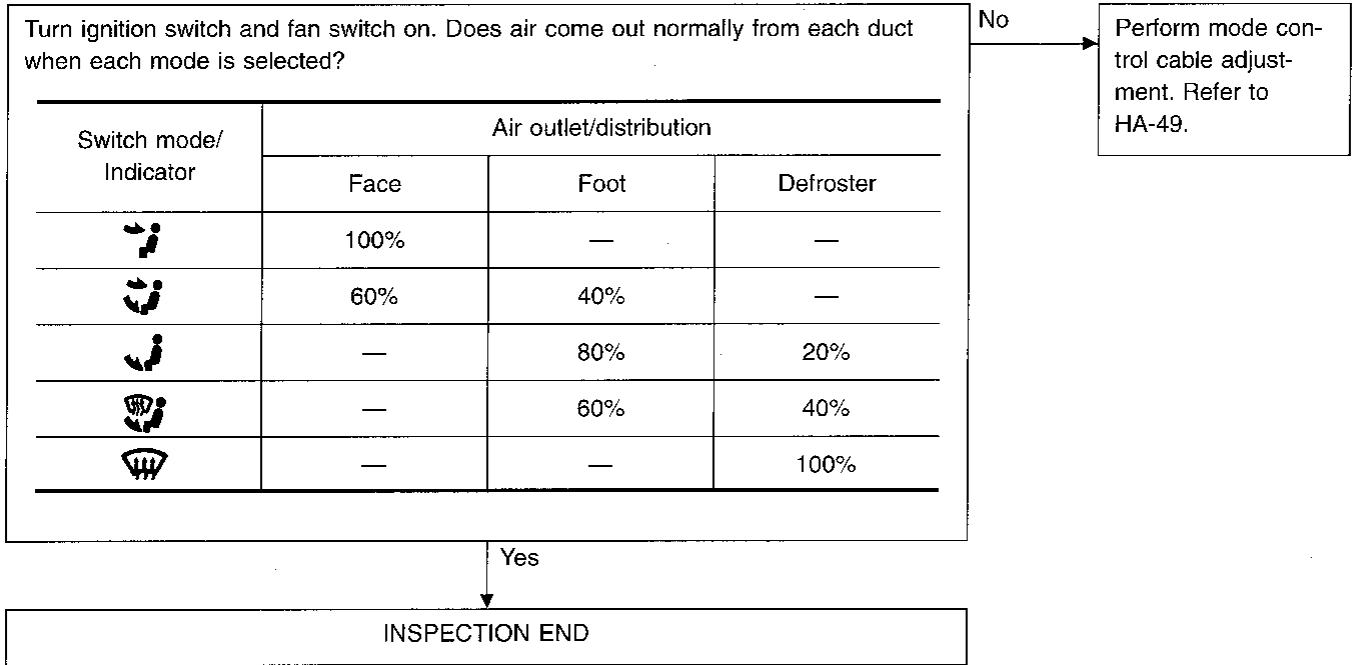

GI  
MA  
EW  
LG  
EC  
FE  
CL  
MT  
AT  
FA  
RA  
BR  
ST  
RS  
BT  
HA  
EL  
DX

# TROUBLE DIAGNOSES

## Preliminary Check (Cont'd)

### PRELIMINARY CHECK 3

#### Noise

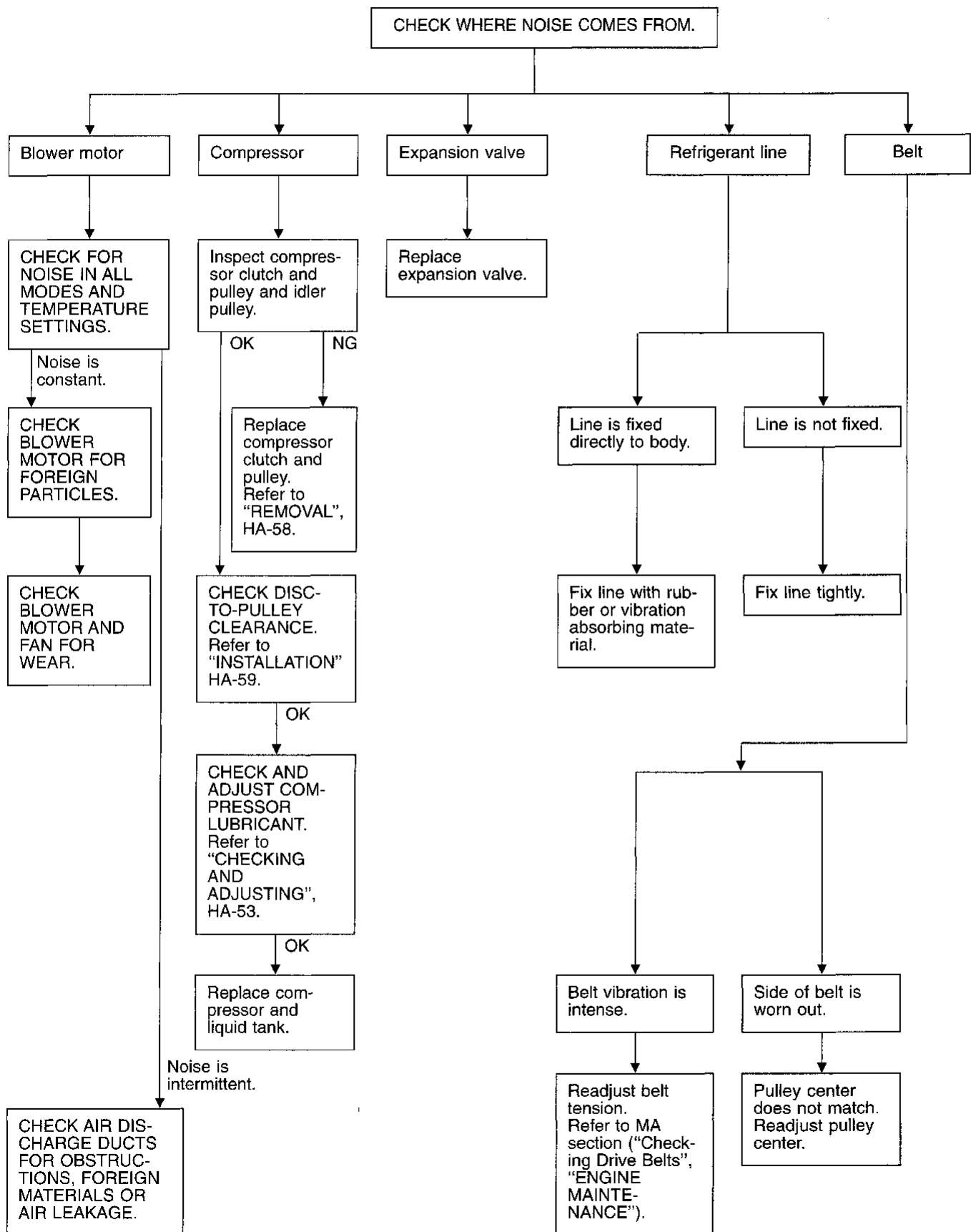

# TROUBLE DIAGNOSES

## Preliminary Check (Cont'd)

### PRELIMINARY CHECK 4

#### Insufficient heating

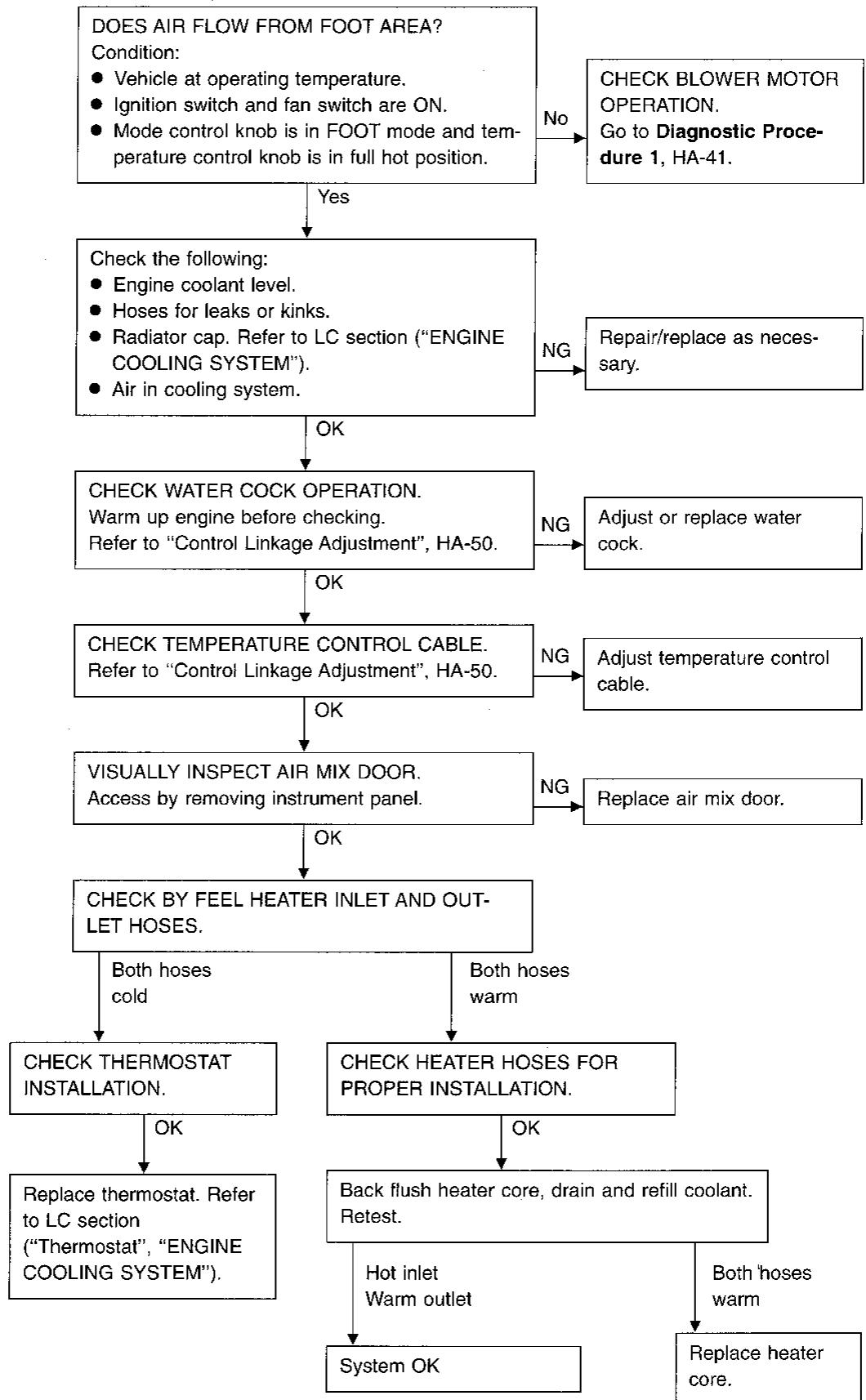

CI  
MA  
EM  
LC  
EC  
FE  
CL  
MT  
AT  
FA  
RA  
BR  
ST  
RS  
BT  
HA  
EL  
DX



# TROUBLE DIAGNOSES

## Performance Test Diagnoses INSUFFICIENT COOLING

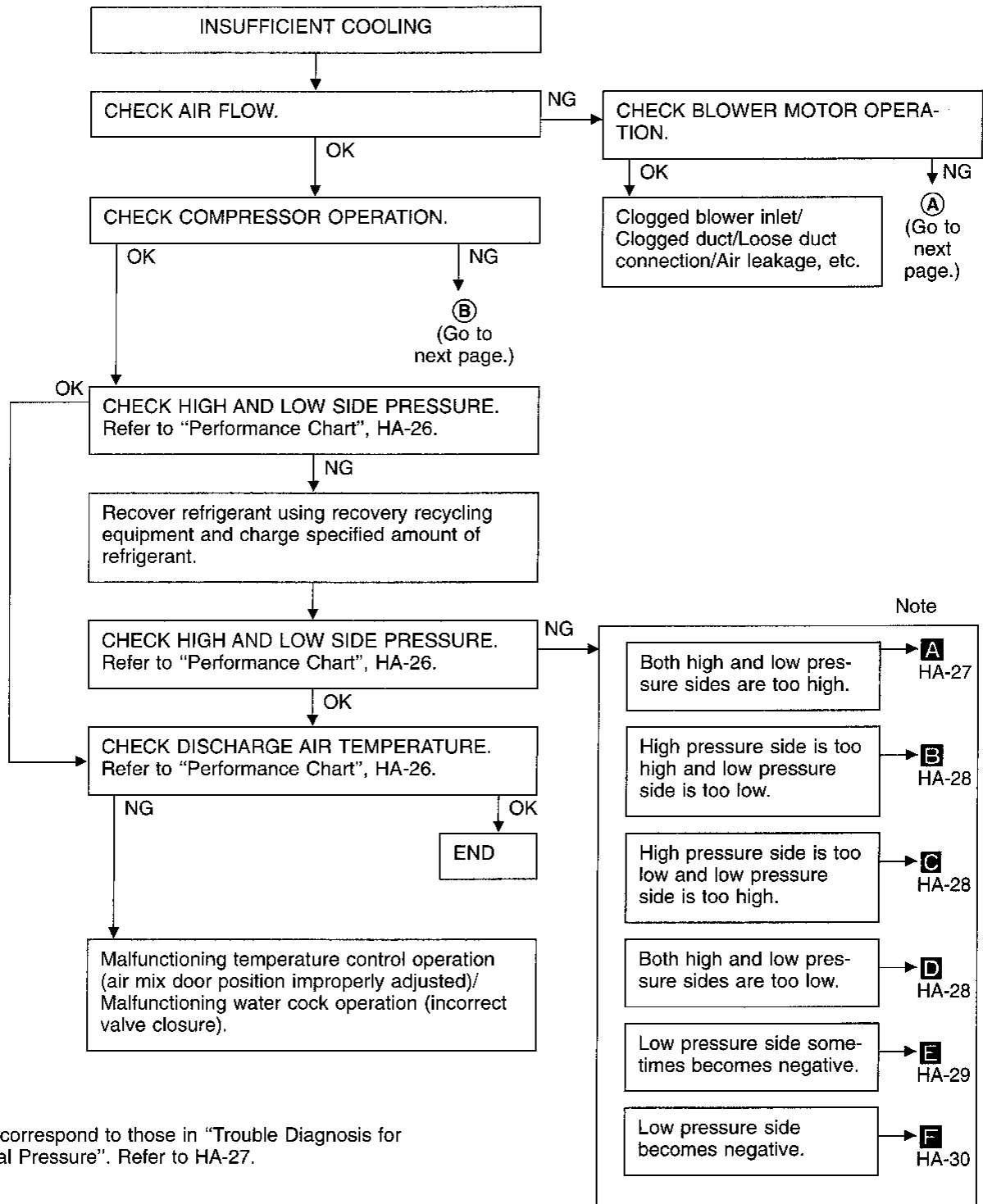

Note: **A-F** correspond to those in "Trouble Diagnosis for Abnormal Pressure". Refer to HA-27.

# TROUBLE DIAGNOSES

## Performance Test Diagnoses (Cont'd)

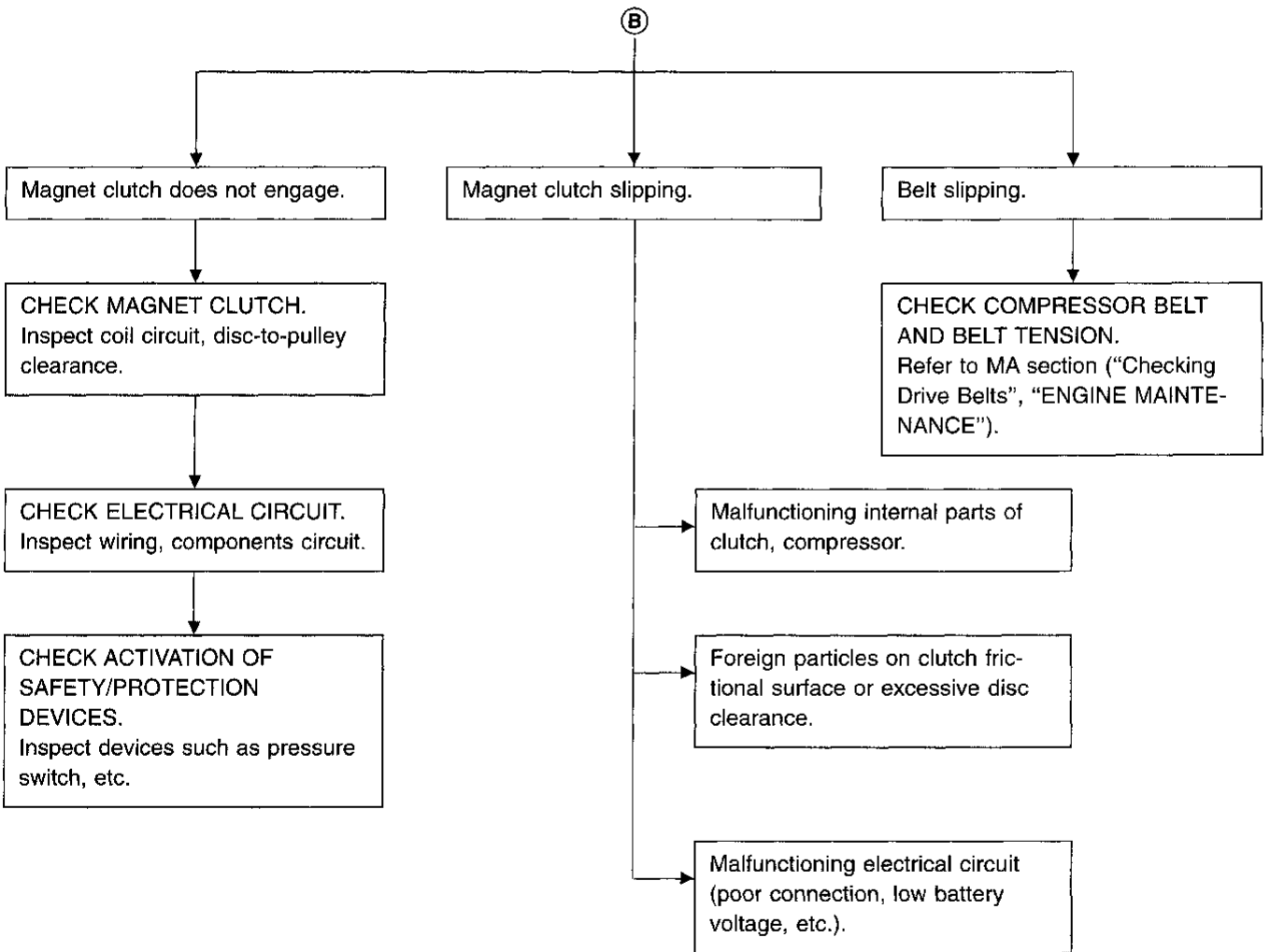
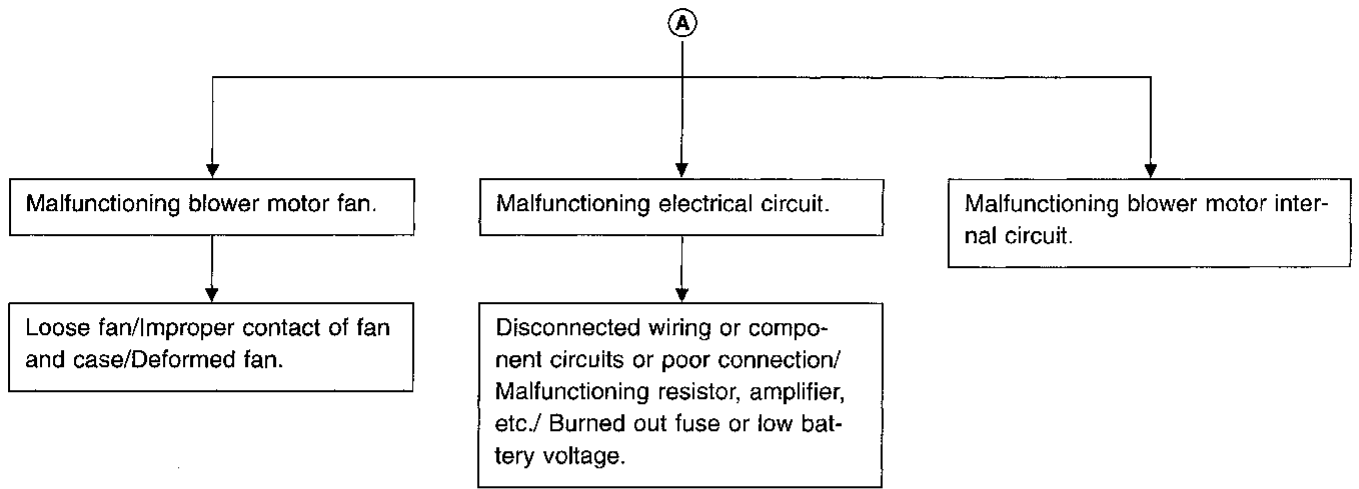

GI  
MA  
EM  
LC  
EC  
FE  
CL  
MT  
AT  
FA  
RA  
BR  
ST  
RS  
BT  
HA  
EL  
IDX

# TROUBLE DIAGNOSES

## Performance Chart

### TEST CONDITION

Testing must be performed as follows:

Vehicle location: Indoors or in the shade (in a well-ventilated place)

Doors: Closed

Door window: Open

Hood: Open

TEMP.: Max. COLD

Discharge Air: Face Vent

REC switch: (Recirculation) set

FAN speed: High speed

Engine speed: Idle speed

Operate the air conditioning system for 10 minutes before taking measurements.

### TEST READING

#### Recirculating-to-discharge air temperature table

Inside air (Recirculating air) at blower assembly inlet		Discharge air temperature at center ventilator °C (°F)
Relative humidity %	Air temperature °C (°F)	
50 - 60	20 (68)	4.4 - 7.0 (40 - 45)
	25 (77)	7.9 - 11.1 (46 - 52)
	30 (86)	11.6 - 15.8 (53 - 60)
	35 (95)	15.4 - 20.4 (60 - 69)
	40 (104)	19.6 - 26.0 (67 - 79)
60 - 70	20 (68)	7.0 - 9.3 (45 - 49)
	25 (77)	11.1 - 14.5 (52 - 58)
	30 (86)	15.8 - 20.2 (60 - 68)
	35 (95)	20.4 - 26.2 (69 - 79)
	40 (104)	26.0 - 33.6 (79 - 92)

#### Ambient air temperature-to-operating pressure table

Ambient air		High-pressure (Discharge side) kPa (kg/cm <sup>2</sup> , psi)	Low-pressure (Suction side) kPa (kg/cm <sup>2</sup> , psi)
Relative humidity %	Air temperature °C (°F)		
50 - 70	20 (68)	1,010 - 1,314 (10.3 - 13.4, 146 - 191)	108 - 206 (1.1 - 2.1, 16 - 30)
	25 (77)	1,236 - 1,599 (12.6 - 16.3, 179 - 232)	118 - 226 (1.2 - 2.3, 17 - 33)
	30 (86)	1,471 - 1,883 (15.0 - 19.2, 213 - 273)	137 - 265 (1.4 - 2.7, 20 - 38)
	35 (95)	1,893 - 2,167 (19.3 - 22.1, 274 - 314)	157 - 324 (1.6 - 3.3, 23 - 47)
	40 (104)	1,922 - 2,452 (19.6 - 25.0, 279 - 356)	196 - 392 (2.0 - 4.0, 28 - 57)

# TROUBLE DIAGNOSES

## Trouble Diagnoses for Abnormal Pressure

Whenever system's high- or low-pressure sides are abnormal, diagnose using a manifold gauge. The marker above the gauge scale indicates the standard (normal) pressure range. However, since the standard (normal) pressure differs from vehicle to vehicle, refer to "Ambient air temperature-to-operating pressure table", HA-26.

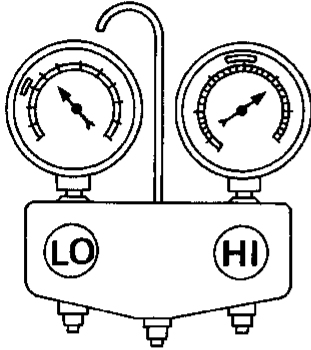
Gauge indication	Refrigerant cycle	Probable cause	Corrective action
<p>Both high- and low-pressure sides are too high.</p> <p><b>A</b></p>  <p>AC359A</p>	<ul style="list-style-type: none"> <li>● Pressure is reduced soon after water is splashed on condenser.</li> </ul>	<ul style="list-style-type: none"> <li>● Excessive refrigerant charge in refrigeration cycle.</li> </ul>	<ul style="list-style-type: none"> <li>● Reduce refrigerant until specified pressure is obtained.</li> </ul>
	<ul style="list-style-type: none"> <li>● Air suction by cooling fan is insufficient.</li> </ul>	<ul style="list-style-type: none"> <li>● Insufficient condenser cooling performance                             <ul style="list-style-type: none"> <li>① Condenser fins are clogged.</li> <li>② Improper rotation of cooling fan.</li> </ul> </li> </ul>	<ul style="list-style-type: none"> <li>● Clean condenser.</li> <li>● Check and repair cooling fan as necessary.</li> </ul>
	<ul style="list-style-type: none"> <li>● Low-pressure pipe is not cold.</li> <li>● When compressor is stopped high-pressure value quickly drops by approximately 196 kPa (2.0 bar, 2 kg/cm<sup>2</sup>, 28 psi). It then decreases gradually thereafter.</li> </ul>	<ul style="list-style-type: none"> <li>● Poor heat exchange in condenser. (After compressor operation stops, high pressure decreases too slowly.)</li> <li>● Air in refrigeration cycle.</li> </ul>	<ul style="list-style-type: none"> <li>● Evacuate repeatedly and recharge system.</li> </ul>
	<ul style="list-style-type: none"> <li>● Engine tends to overheat.</li> </ul>	<ul style="list-style-type: none"> <li>● Engine cooling systems malfunction.</li> </ul>	<ul style="list-style-type: none"> <li>● Check and repair each engine cooling system.</li> </ul>
	<ul style="list-style-type: none"> <li>● An area of the low-pressure pipe is colder than areas near the evaporator outlet.</li> <li>● Plates are sometimes covered with frost.</li> </ul>	<ul style="list-style-type: none"> <li>● Excessive liquid refrigerant on low-pressure side.</li> <li>● Excessive refrigerant discharge flow.</li> <li>● Expansion valve is open a little compared with the specification.                             <ul style="list-style-type: none"> <li>① Improper thermal valve installation.</li> <li>② Improper expansion valve adjustment.</li> </ul> </li> </ul>	<ul style="list-style-type: none"> <li>● Replace expansion valve.</li> </ul>

GI

MA

EM

LC

EC

FE

CL

MT

AT

FA

RA

BR

ST

RS

BT

HA

EL

IDX

# TROUBLE DIAGNOSES

## Trouble Diagnoses for Abnormal Pressure (Cont'd)

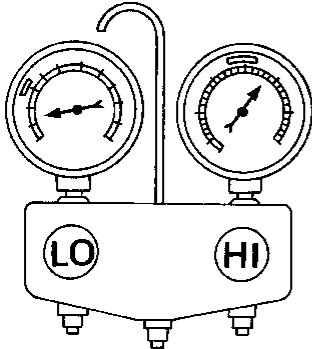
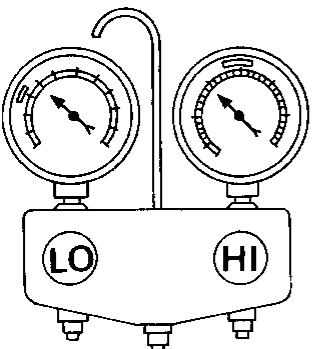
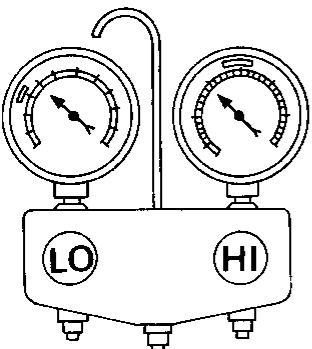
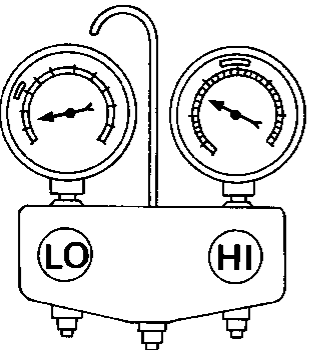
Gauge indication	Refrigerant cycle	Probable cause	Corrective action
<p>High-pressure side is too high and low-pressure side is too low.</p> <p><b>B</b></p>  <p>AC360A</p>	<ul style="list-style-type: none"> <li>Upper side of condenser and high-pressure side are hot, however, liquid tank is not as hot.</li> </ul>	<ul style="list-style-type: none"> <li>High-pressure tube or parts located between compressor and condenser are clogged or crushed.</li> </ul>	<ul style="list-style-type: none"> <li>Check and repair or replace malfunctioning parts.</li> <li>Check lubricant for contamination.</li> </ul>
<p>High-pressure side is too low and low-pressure side is too high.</p> <p><b>C</b></p>  <p>AC356A</p>	<ul style="list-style-type: none"> <li>High- and low-pressure sides become equal soon after compressor operation stops.</li> </ul>	<ul style="list-style-type: none"> <li>Compressor pressure operation is improper.                             <ul style="list-style-type: none"> <li>↓</li> </ul> </li> <li>Damaged inside compressor packings.</li> </ul>	<ul style="list-style-type: none"> <li>Replace compressor.</li> </ul>
<p>High-pressure side is too low and low-pressure side is too high.</p> <p><b>C</b></p>  <p>AC356A</p>	<ul style="list-style-type: none"> <li>No temperature difference between high- and low-pressure sides.</li> </ul>	<ul style="list-style-type: none"> <li>Compressor pressure operation is improper.                             <ul style="list-style-type: none"> <li>↓</li> </ul> </li> <li>Damaged inside compressor packings.</li> </ul>	<ul style="list-style-type: none"> <li>Replace compressor.</li> </ul>
<p>Both high- and low-pressure sides are too low.</p> <p><b>D</b></p>  <p>AC353A</p>	<ul style="list-style-type: none"> <li>There is a big temperature difference between liquid tank outlet and inlet. Outlet temperature is extremely low.</li> <li>Liquid tank inlet and expansion valve are frosted.</li> <li>Temperature of expansion valve inlet is extremely low as compared with areas near liquid tank.</li> <li>Expansion valve inlet may be frosted.</li> <li>Temperature difference occurs somewhere in high-pressure side.</li> </ul>	<ul style="list-style-type: none"> <li>Liquid tank is partly clogged.</li> <li>High-pressure pipe located between liquid tank and expansion valve is clogged.</li> </ul>	<ul style="list-style-type: none"> <li>Replace liquid tank.</li> <li>Check lubricant for contamination.</li> <li>Check and repair malfunctioning parts.</li> <li>Check lubricant for contamination.</li> </ul>

# TROUBLE DIAGNOSES

## Trouble Diagnoses for Abnormal Pressure (Cont'd)

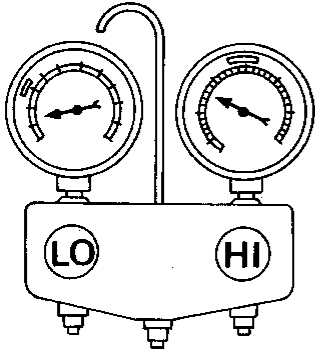
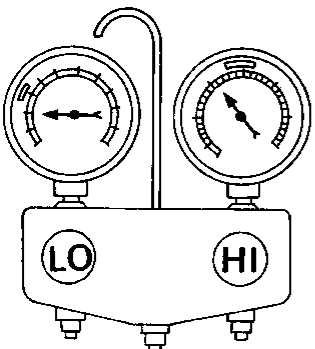
Gauge indication	Refrigerant cycle	Probable cause	Corrective action
<p>Both high- and low-pressure sides are too low.</p> <p><b>D</b></p>  <p>AC353A</p>	<ul style="list-style-type: none"> <li>There is a big temperature difference between expansion valve inlet and outlet while the valve itself is frosted.</li> </ul>	<ul style="list-style-type: none"> <li>Expansion valve closed and past the specification.                             <ul style="list-style-type: none"> <li>Improper expansion valve adjustment.</li> <li>Malfunctioning thermal valve.</li> <li>Outlet and inlet may be clogged.</li> </ul> </li> </ul>	<ul style="list-style-type: none"> <li>Remove foreign particles by using compressed air.</li> <li>Check lubricant for contamination.</li> </ul>
	<ul style="list-style-type: none"> <li>An area of the low-pressure pipe is colder than areas near the evaporator outlet.</li> </ul>	<ul style="list-style-type: none"> <li>Low-pressure pipe is clogged or crushed.</li> </ul>	<ul style="list-style-type: none"> <li>Check and repair malfunctioning parts.</li> <li>Check lubricant for contamination.</li> </ul>
	<ul style="list-style-type: none"> <li>Air flow volume is not enough or is too low.</li> </ul>	<ul style="list-style-type: none"> <li>Evaporator is frozen.</li> </ul>	<ul style="list-style-type: none"> <li>Replace compressor.</li> </ul>
<p>Low-pressure side sometimes becomes negative.</p> <p><b>E</b></p>  <p>AC354A</p>	<ul style="list-style-type: none"> <li>Air conditioning system does not function and does not cyclically cool the compartment air.</li> <li>The system constantly functions for a certain period of time after compressor is stopped and restarted.</li> </ul>	<ul style="list-style-type: none"> <li>Refrigerant does not discharge cyclically.                             <ul style="list-style-type: none"> <li>Moisture is frozen at expansion valve outlet and inlet.                                     <ul style="list-style-type: none"> <li>Water is mixed with refrigerant.</li> </ul> </li> </ul> </li> </ul>	<ul style="list-style-type: none"> <li>Replace refrigerant.</li> <li>Replace liquid tank.</li> </ul>

GI  
MA  
EM  
LC  
EC  
FE  
CL  
MT  
AT  
FA  
RA  
BR  
ST  
PS  
BT  
HA  
EL  
IDX

## TROUBLE DIAGNOSES

### Trouble Diagnoses for Abnormal Pressure (Cont'd)

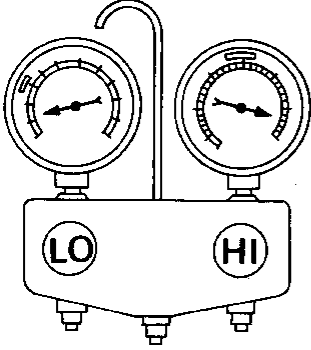
Gauge indication	Refrigerant cycle	Probable cause	Corrective action
<p>Low-pressure side becomes negative.</p> <p><b>F</b></p>  <p style="text-align: right;">AC362A</p>	<ul style="list-style-type: none"> <li>• Liquid tank or front/rear side of expansion valve pipe is frosted or dewed.</li> </ul>	<ul style="list-style-type: none"> <li>• High-pressure side is closed and refrigerant does not flow.</li> </ul> <p style="text-align: center;">↓</p> <ul style="list-style-type: none"> <li>• Expansion valve or liquid tank is frosted.</li> </ul>	<ul style="list-style-type: none"> <li>• Leave the system at rest until no frost is present. Start it again to check if the problem is caused by water or foreign particles.</li> <li>• If water is the cause, initially cooling is okay. Then the water freezes, causing a blockage.</li> <li>• Replace refrigerant.</li> <li>• If due to foreign particles, remove expansion valve and remove the particles with dry and compressed air (not shop air).</li> <li>• If either of the above methods cannot correct the problem, replace expansion valve.</li> <li>• Replace liquid tank.</li> <li>• Check lubricant for contamination.</li> </ul>

## Harness Layout

### ENGINE COMPARTMENT

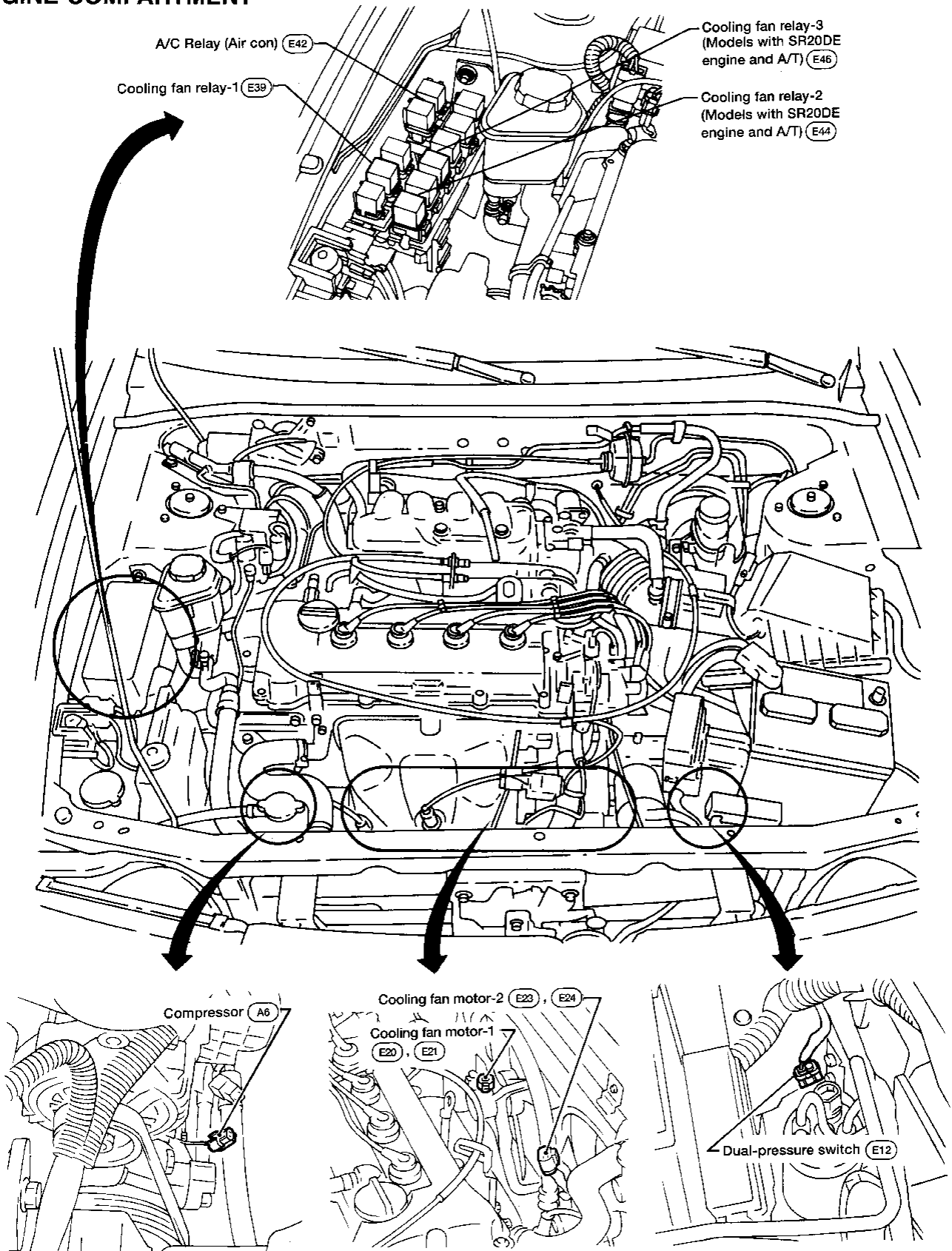

(E21) (E23) : Except models with SR20DE engine and A/T

(E20) (E24) : Models with SR20DE engine and A/T

CI  
 MA  
 EM  
 LC  
 EC  
 FE  
 CL  
 NT  
 AT  
 FA  
 RA  
 BR  
 ST  
 RS  
 BT  
HA  
 EL  
 IDX



# TROUBLE DIAGNOSES

## Harness Layout (Cont'd)

### PASSENGER COMPARTMENT

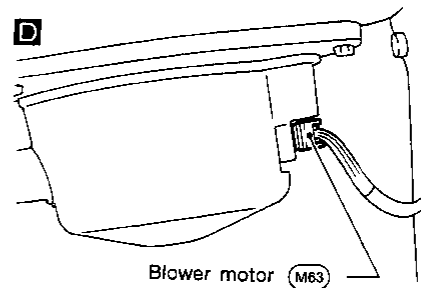
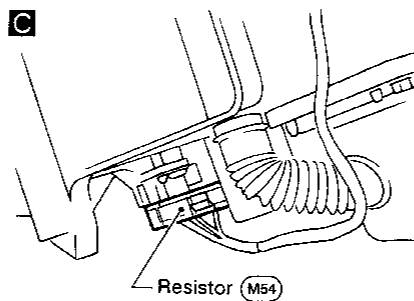
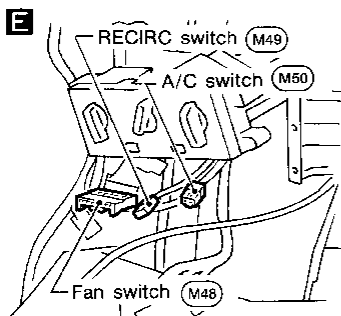
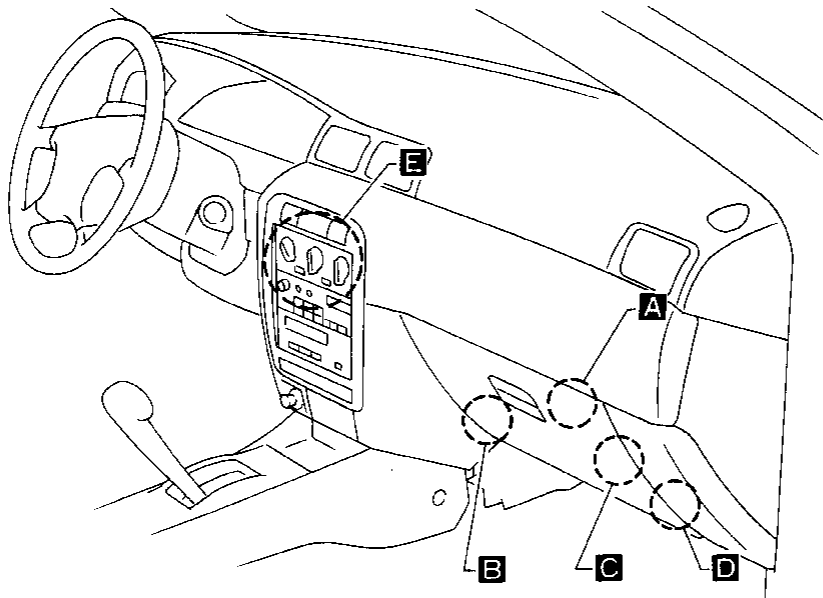
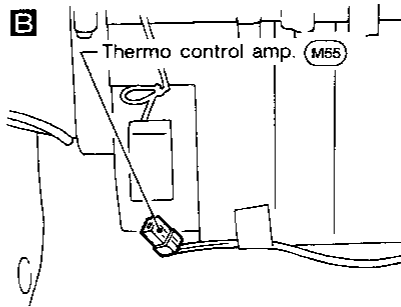
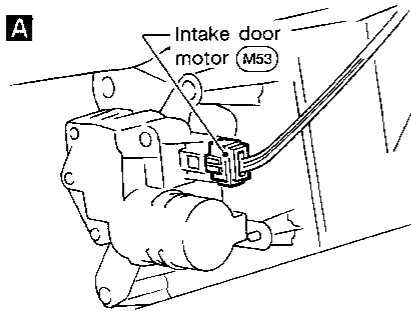

# TROUBLE DIAGNOSES

## Circuit Diagram — Air Conditioner

GA ENGINE

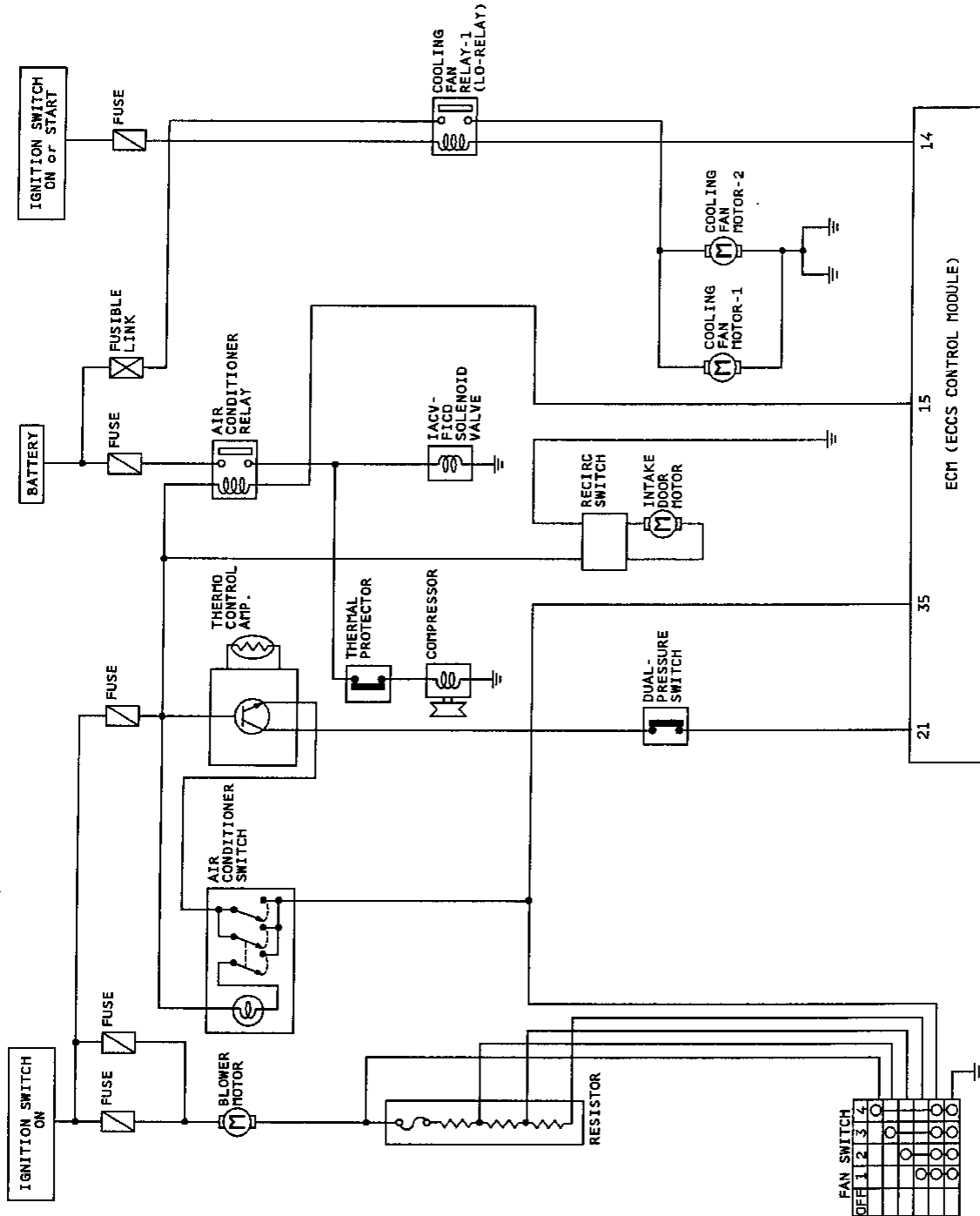

GI

MA

EM

LC

EC

FE

CL

MT

AT

FA

RA

BR

ST

RS

BT

HA

EL

IDX

# TROUBLE DIAGNOSES

## Circuit Diagram — Air Conditioner (Cont'd)

SR ENGINE

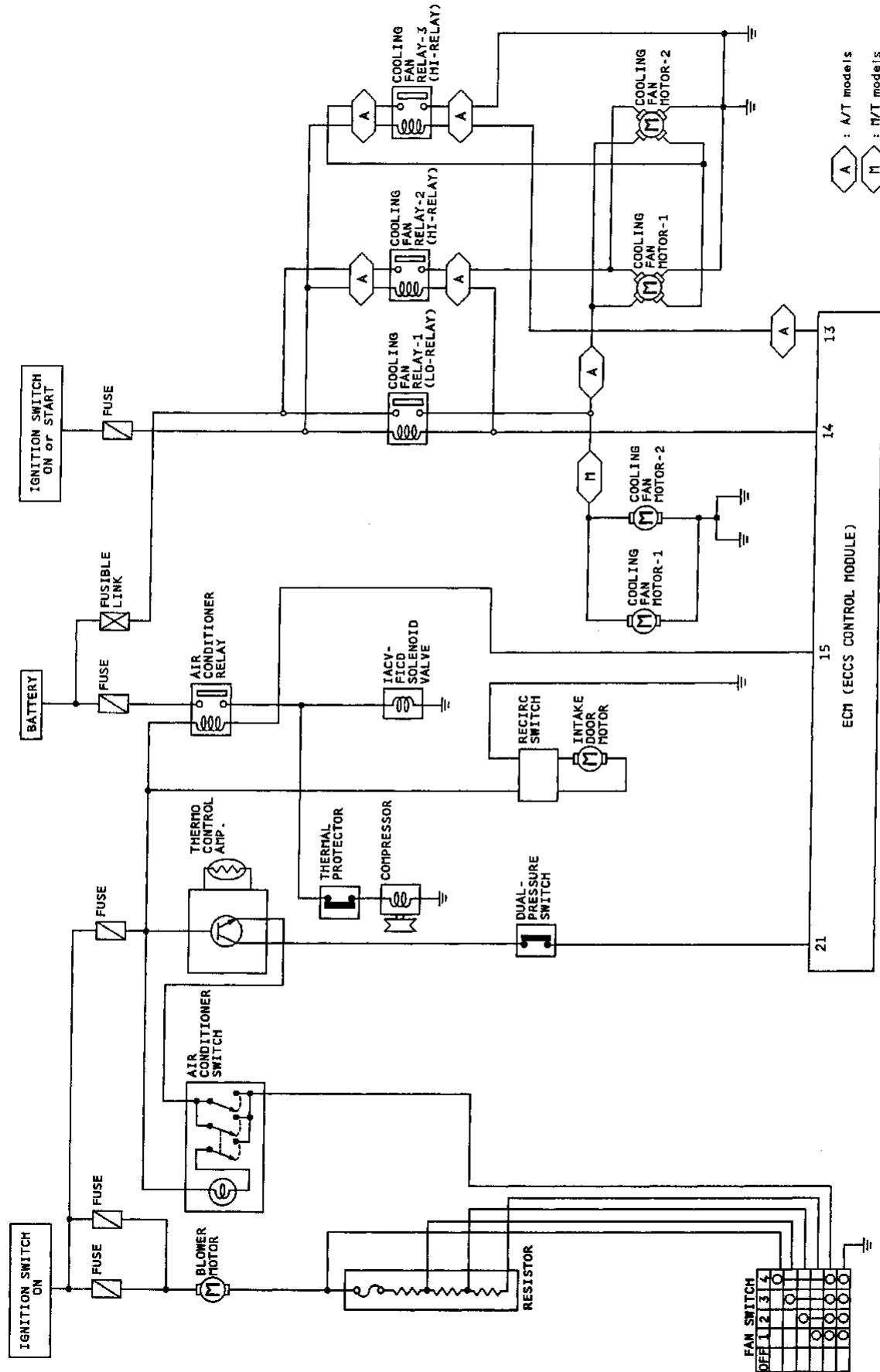

# TROUBLE DIAGNOSES

## Wiring Diagram -HEATER-

HA-HEATER-01

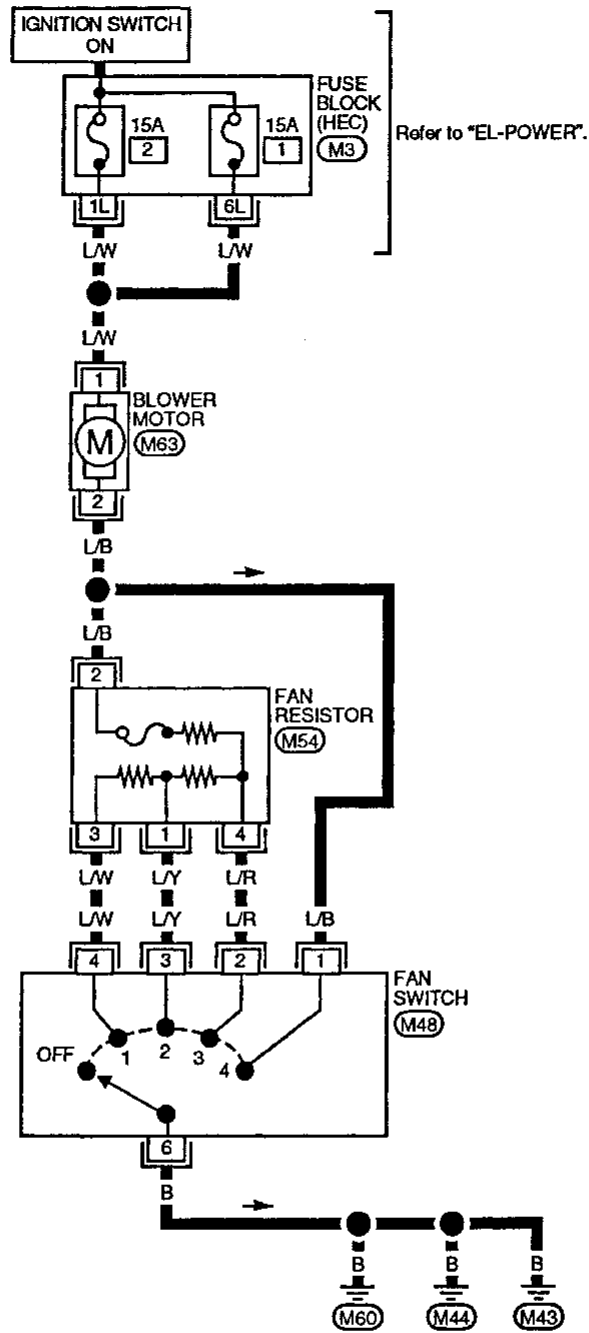

GI  
MA  
EM  
LC  
EC  
FE  
CL  
MT  
AT  
FA  
RA  
BR  
ST  
RS  
BT

Refer to last page (Foldout page).

(M3)



HA

EL

IDX

# TROUBLE DIAGNOSES

## Wiring Diagram -A/C-

HA-A/C-01

Refer to "EL-POWER".

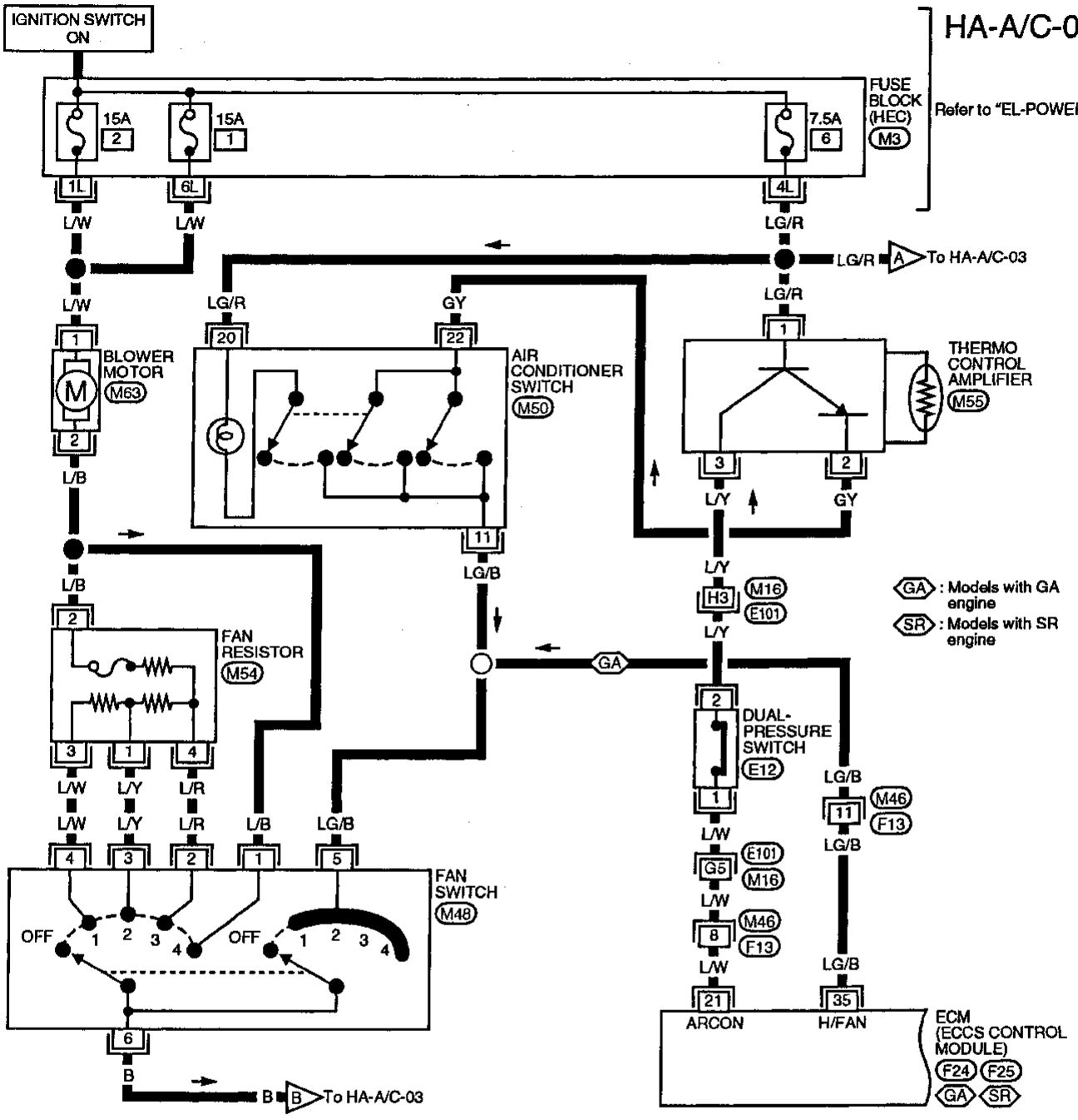

GA : Models with GA engine  
SR : Models with SR engine

ECM (ECCS CONTROL MODULE)  
F24 F25  
GA SR

Refer to last page (Foldout page).

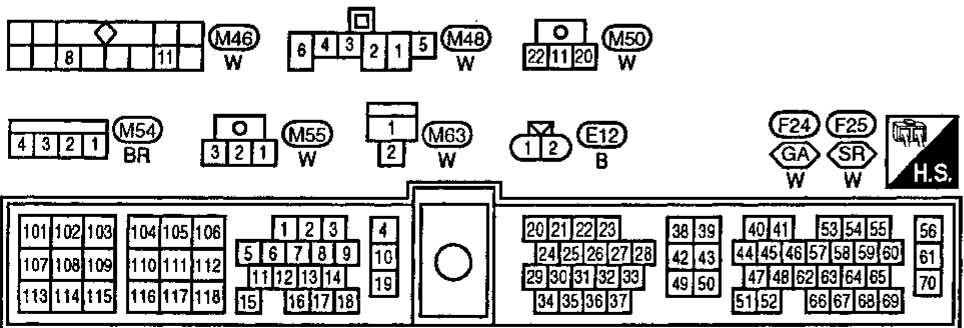

M3  
M16, E101

# TROUBLE DIAGNOSES

## Wiring Diagram -A/C- (Cont'd)

HA-A/C-02

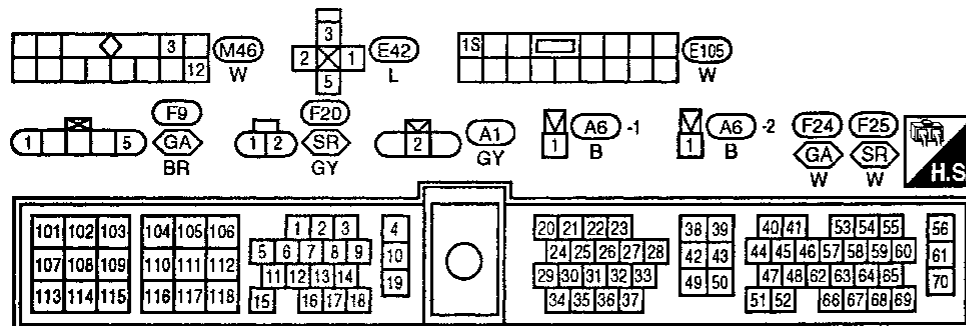
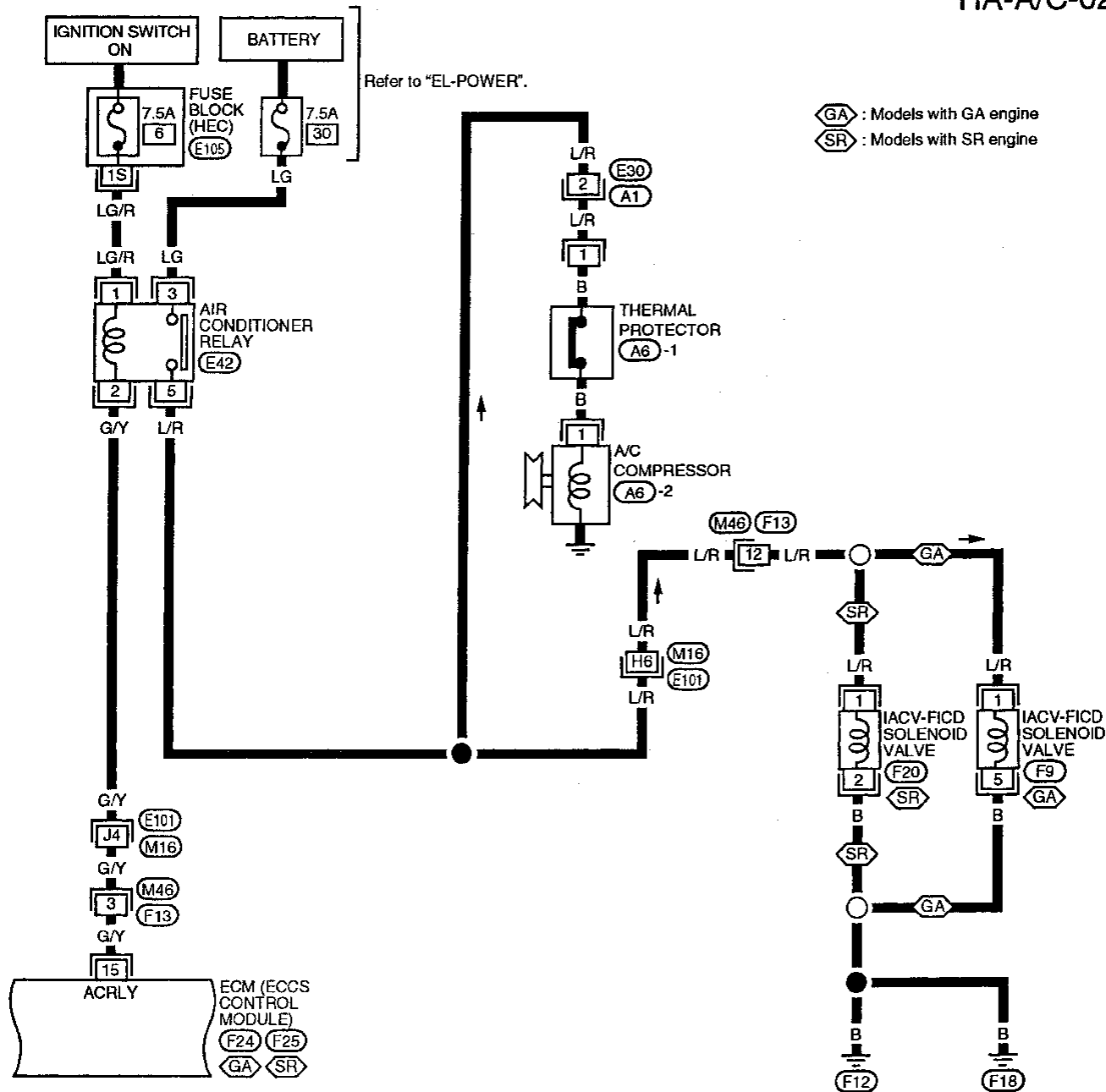

Refer to last page (Foldout page).  
(M16), (E101)

GI  
HA  
EM  
LC  
EC  
FE  
CL  
MT  
AT  
FA  
RA  
BR  
ST  
RS  
BT

HA

EL

IDX

# TROUBLE DIAGNOSES

## Wiring Diagram -A/C- (Cont'd)

HA-A/C-03

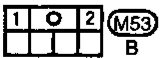
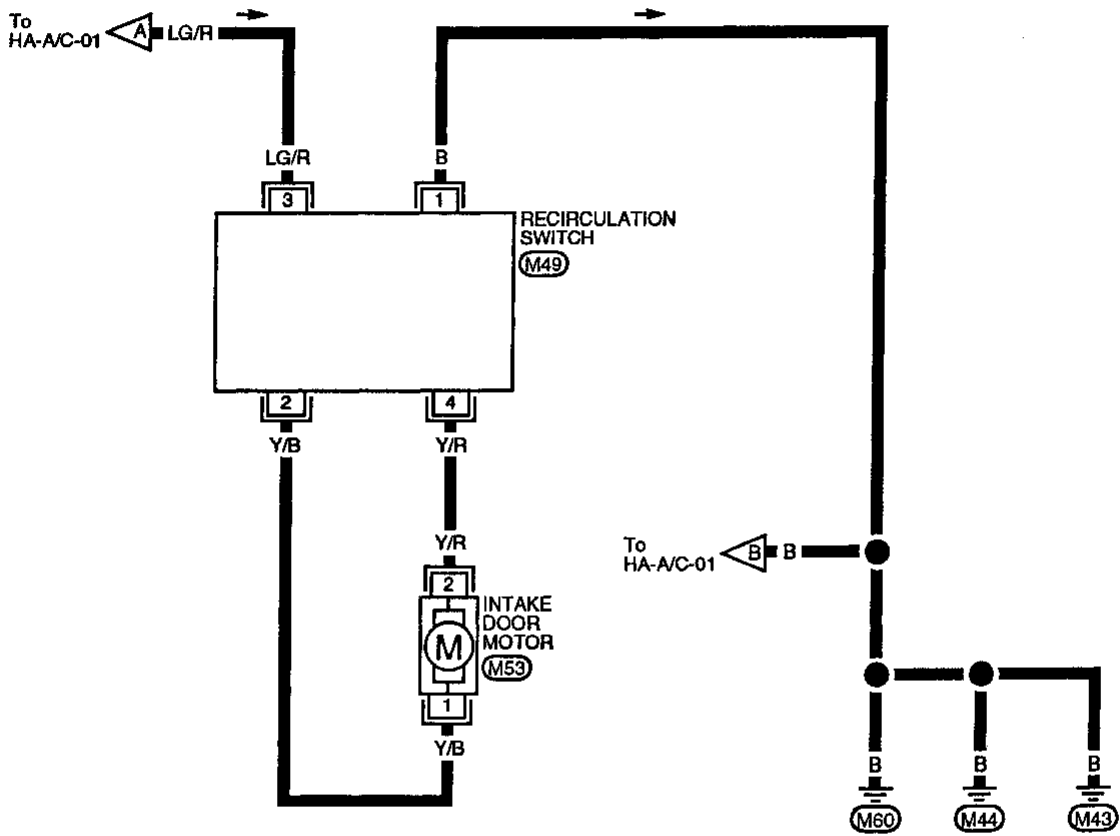

# TROUBLE DIAGNOSES

## Wiring Diagram -A/C- (Cont'd)

HA-A/C-04

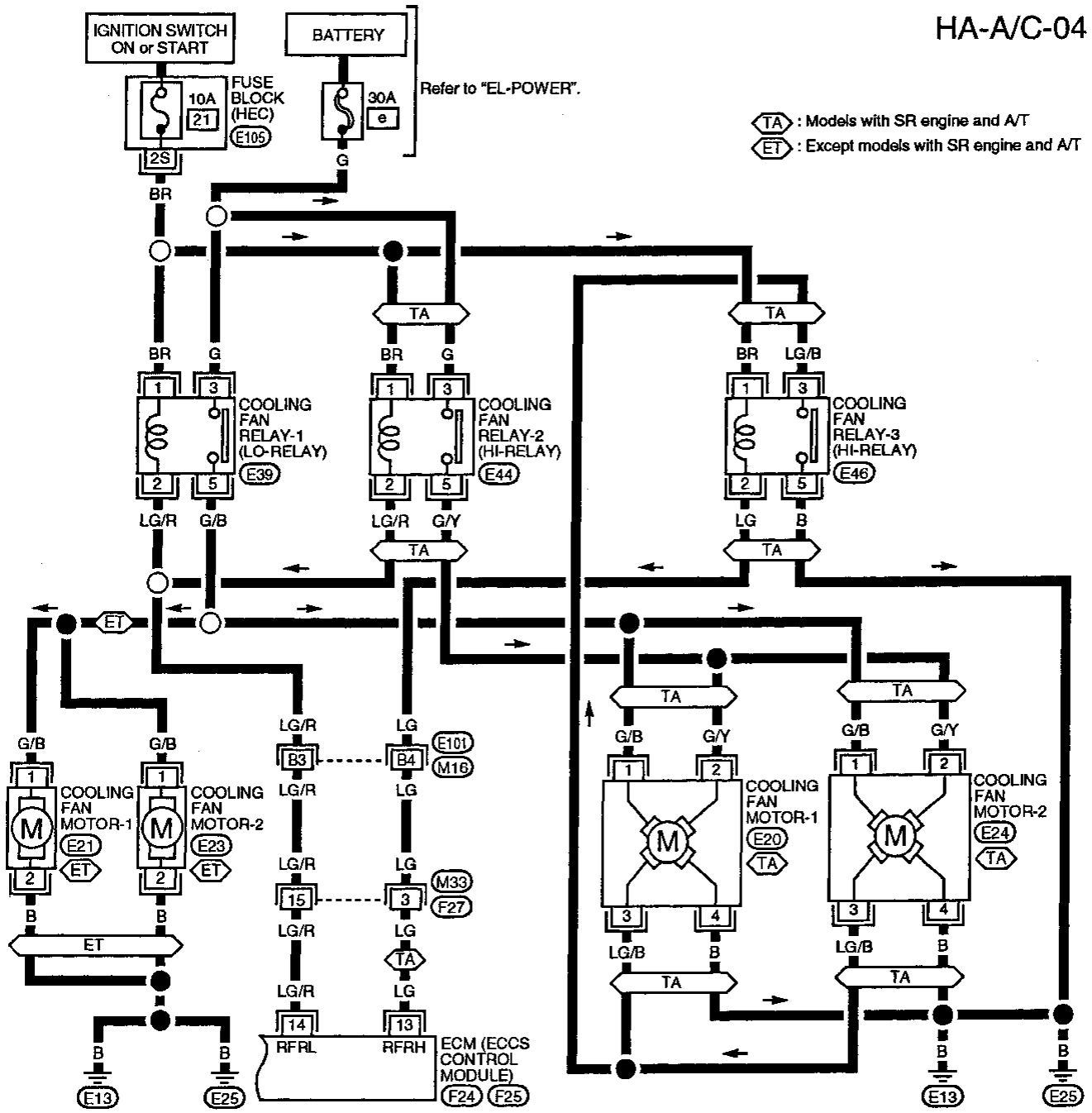

TA : Models with SR engine and A/T  
 ET : Except models with SR engine and A/T

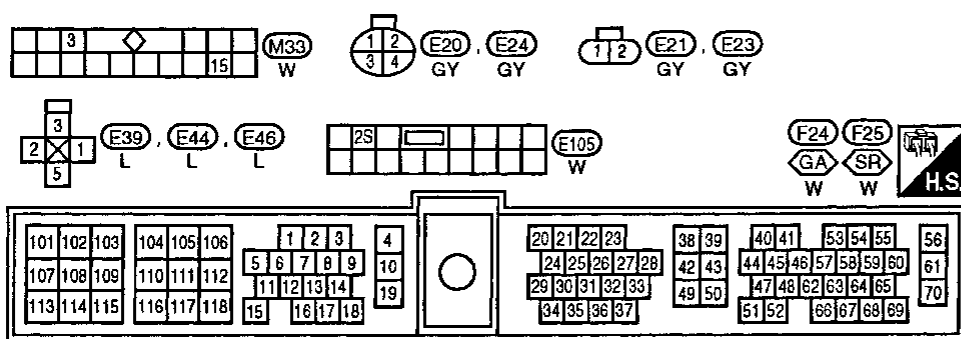

Refer to last page (Foldout page).  
 M16, E101

GI  
 MA  
 EM  
 LC  
 EC  
 FE  
 CL  
 MT  
 AT  
 FA  
 RA  
 BR  
 ST  
 RS  
 BT

HA

EL

IDX



## Main Power Supply and Ground Circuit Check

### POWER SUPPLY CIRCUIT CHECK FOR A/C SYSTEM

Check power supply circuit for air conditioning system.

Refer to EL section ("Wiring Diagram", "POWER SUPPLY ROUTING").

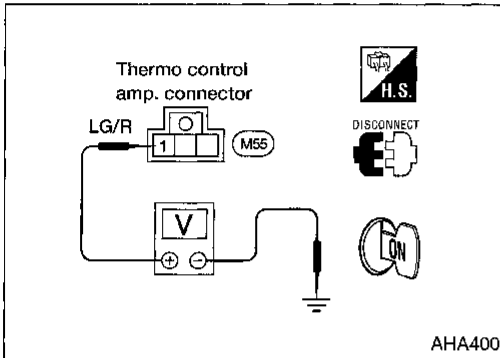

### THERMO CONTROL AMP. CHECK

Check power supply circuit for thermo control amp. with ignition switch ON.

1. Disconnect thermo control amp. harness connector.
2. Connect voltmeter from harness side.
3. Measure voltage across terminal ① and body ground.

Voltmeter terminal		Voltage
⊕	⊖	
①	Body ground	Approx. 12V

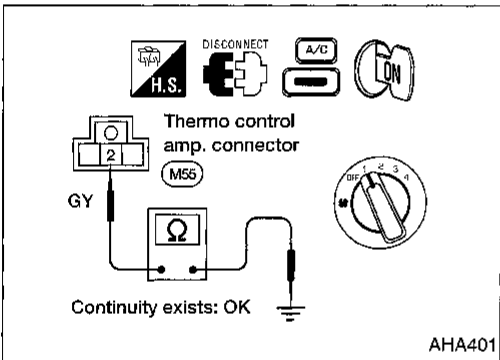

Turn ignition, A/C and fan switches ON. Check body ground circuit for thermo control amp.

1. Disconnect thermo control amp. harness connector.
2. Connect ohmmeter from harness side.
3. Check for continuity between terminal ② and body ground.

Ohmmeter terminal		Continuity
⊕	⊖	
②	Body ground	Yes

# TROUBLE DIAGNOSES

	INCIDENT	Flow chart No.
1	Fan fails to rotate.	1
2	Fan does not rotate at 1-speed.	2
3	Fan does not rotate at 2-speed.	3
4	Fan does not rotate at 3-speed.	4
5	Fan does not rotate at 4-speed.	5

## Diagnostic Procedure 1

**SYMPTOM: Blower motor does not rotate.**

- Perform **PRELIMINARY CHECK 1** before referring to the following flow chart.

Check if blower motor rotates properly at each fan speed. Conduct check as per flow chart at left.

2 3 4 5  
(Go to next page.) → B

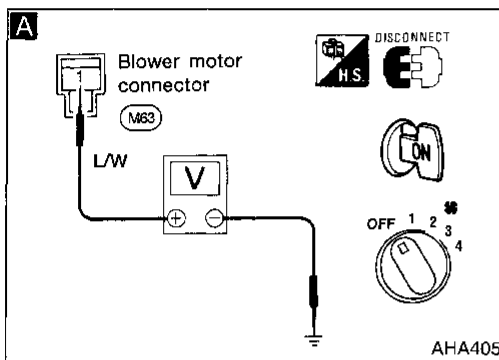

**A**

**CHECK POWER SUPPLY FOR BLOWER MOTOR.**  
Disconnect blower motor harness connector.  
Do approx. 12 volts exist between blower motor harness terminal ① and body ground?

No → [Check 15A fuses at fuse block. Refer to EL section ("Wiring Diagram", "POWER SUPPLY ROUTING").]

Yes → [B]

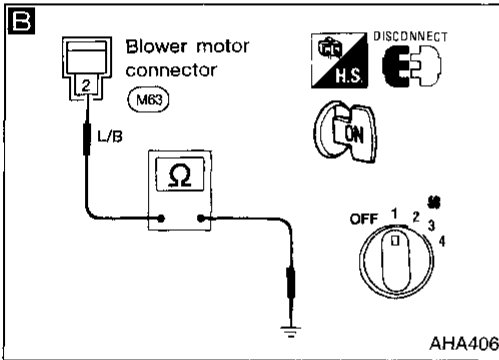

**B**

**CHECK CIRCUIT CONTINUITY BETWEEN BLOWER MOTOR HARNESS TERMINAL ② AND BODY GROUND.**

OK → [CHECK BLOWER MOTOR. Refer to HA-48.]

NG → [Reconnect blower motor harness connector.]

NG → [C]

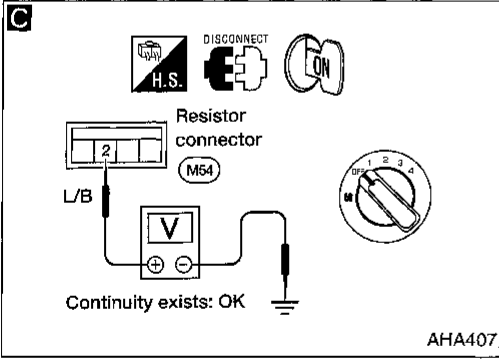

**C**

**CHECK BLOWER MOTOR CIRCUIT BETWEEN BLOWER MOTOR AND RESISTOR.**  
Do approx. 12 volts exist between resistor harness terminal ② and body ground?

No → [Disconnect blower motor and resistor harness connectors.]

Yes → [A]

**D**

**CHECK CIRCUIT CONTINUITY BETWEEN BLOWER MOTOR HARNESS TERMINAL ② AND RESISTOR HARNESS TERMINAL ②.**

Note

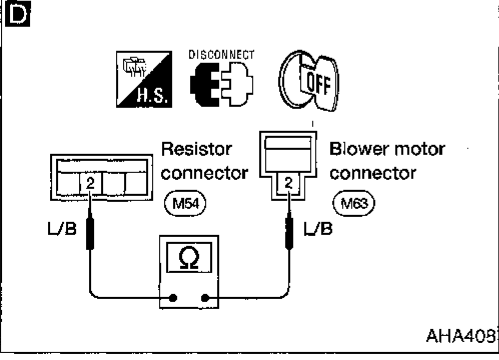

Reconnect blower motor harness connector.

→ [A]

(Go to next page.)

**Note:**  
If the result is NG or No after checking circuit continuity, repair harness or connector.

GI  
MA  
EM  
LC  
EC  
FE  
CL  
MT  
AT  
FA  
RA  
BR  
ST  
RS  
BT  
HA  
EL  
IDX

# TROUBLE DIAGNOSES

## Diagnostic Procedure 1 (Cont'd)

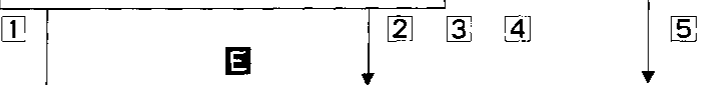
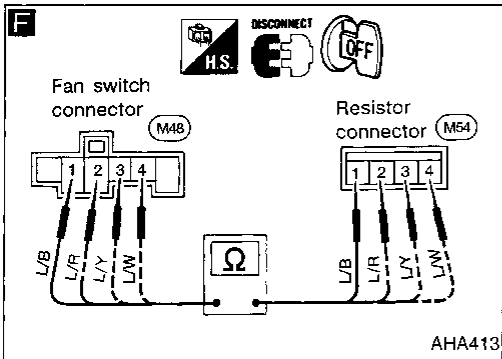
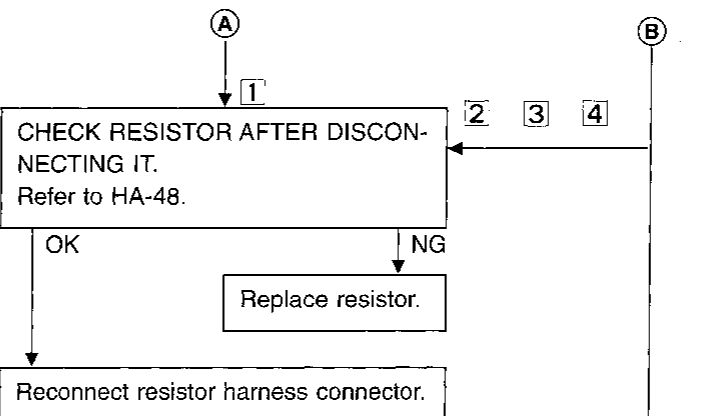
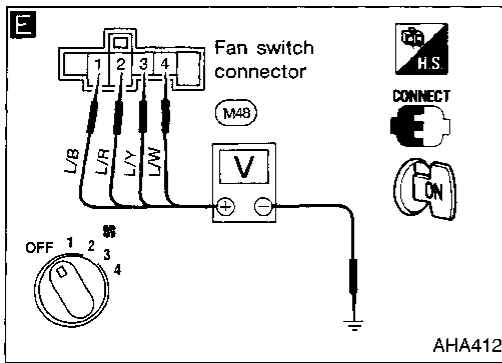
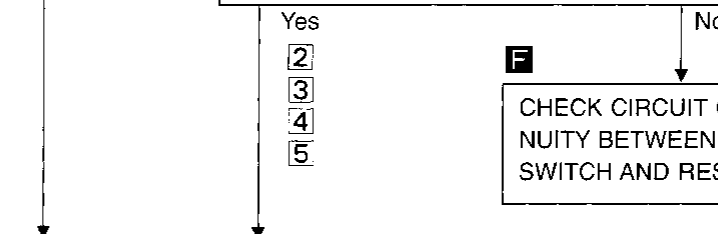
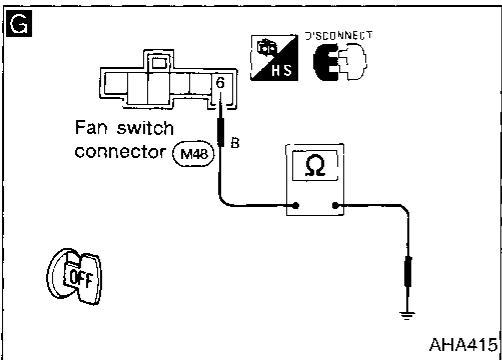
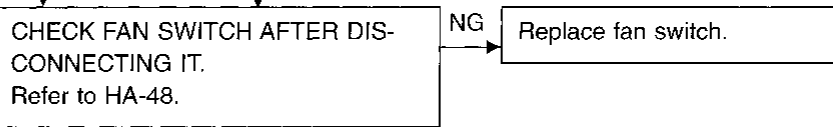

Diagram E: CHECK FAN SWITCH CIRCUIT. Do approx. 12 volts exist between each fan switch harness terminal and body ground?

Flow chart No.	Terminal No.		Voltage
	⊕	⊖	
2	4	Body ground	Approx. 12V
3	3		
4	2		
5	1		



Note: CHECK CIRCUIT CONTINUITY BETWEEN FAN SWITCH AND RESISTOR.



Note: CHECK CIRCUIT CONTINUITY BETWEEN FAN SWITCH HARNESS TERMINAL 6 AND BODY GROUND.

Replace blower motor.

Note: If the result is NG or No after checking circuit continuity, repair harness or connector.

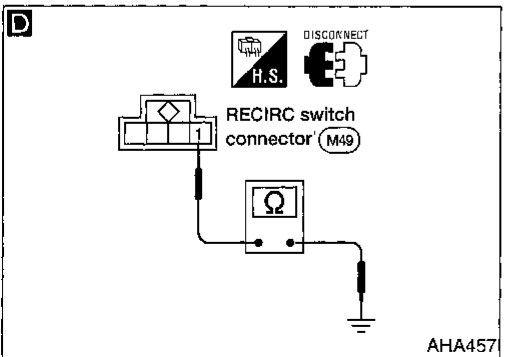
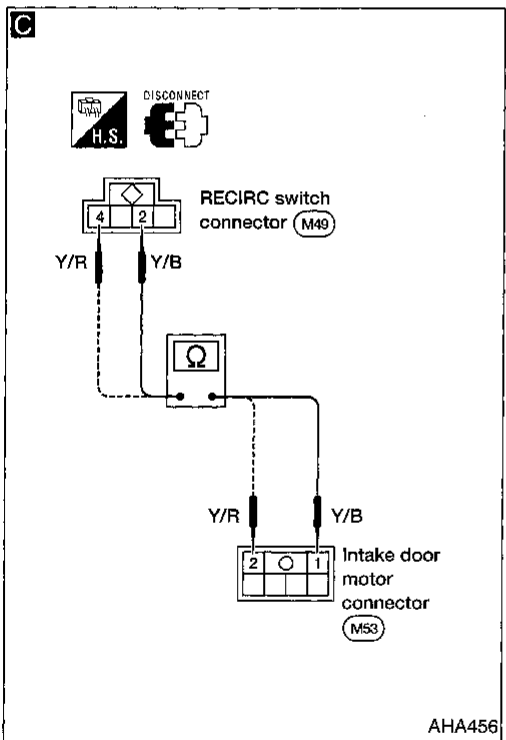
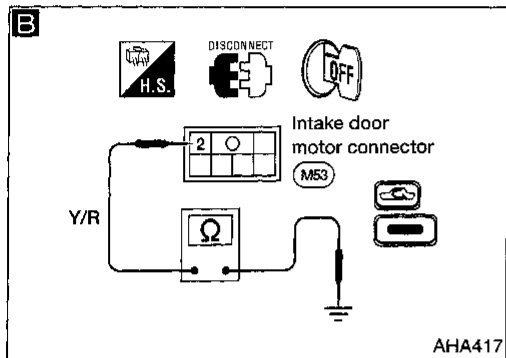
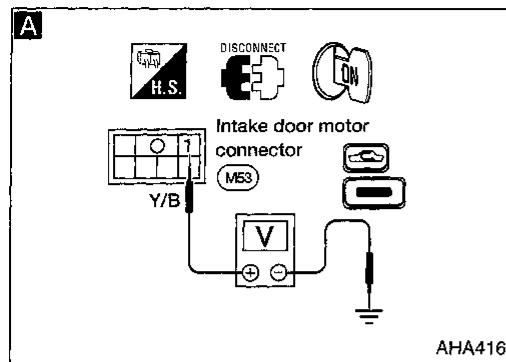

## Diagnostic Procedure 2

**SYMPTOM:** Intake door does not operate.

- Perform Main Power Supply and Ground Circuit check before referring to the following flow chart.

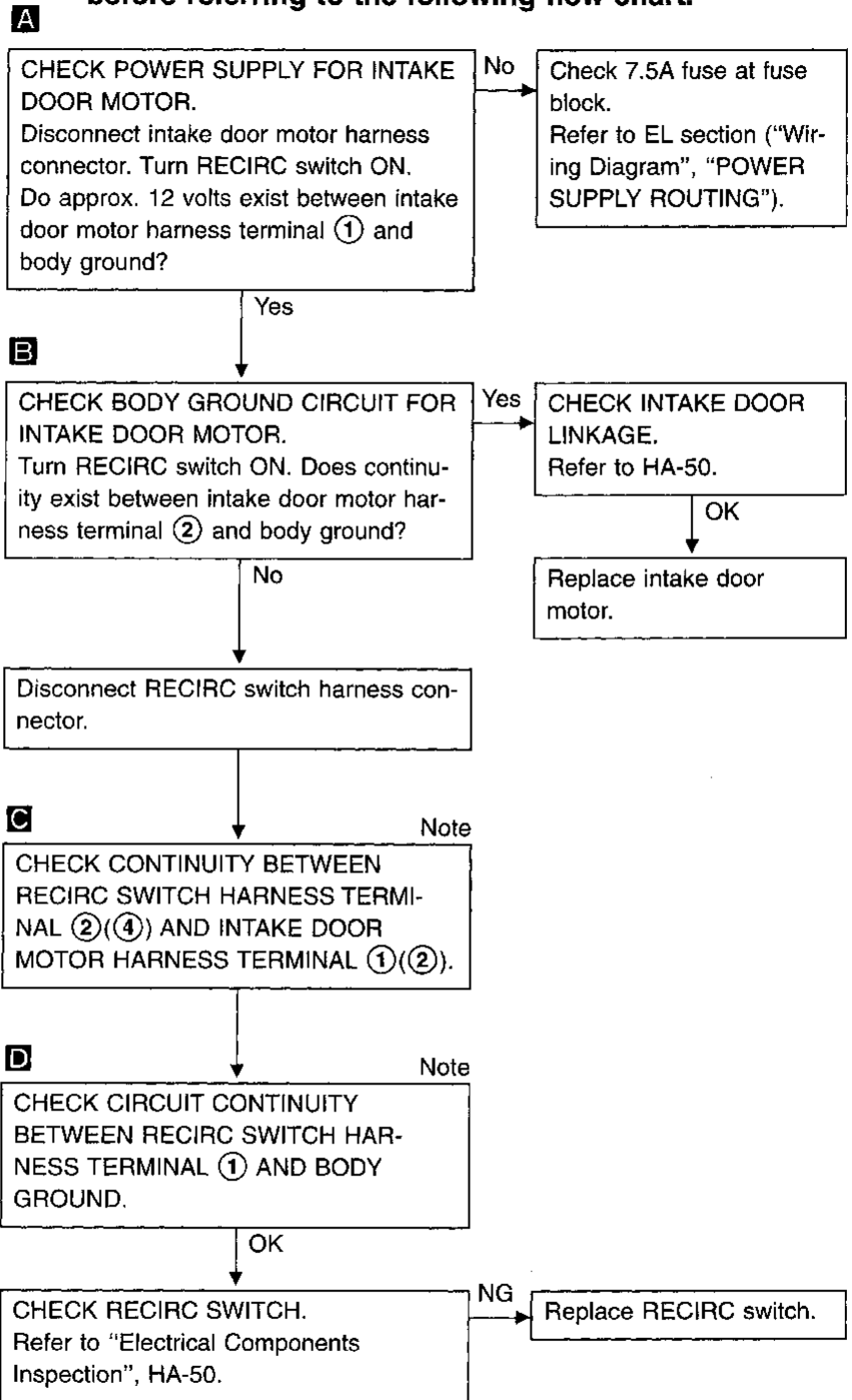

**Note:** If the result is NG or No after checking circuit continuity, repair harness or connector.

GI  
 MA  
 EM  
 LC  
 EC  
 FE  
 CL  
 MT  
 AT  
 FA  
 RA  
 BR  
 ST  
 RS  
 BT  
 HA  
 EL  
 IDX

# TROUBLE DIAGNOSES

## Diagnostic Procedure 3

**SYMPTOM: Magnet clutch does not engage when A/C switch and fan switch are ON.**

- Perform PRELIMINARY CHECK 1 before referring to the following flow chart.

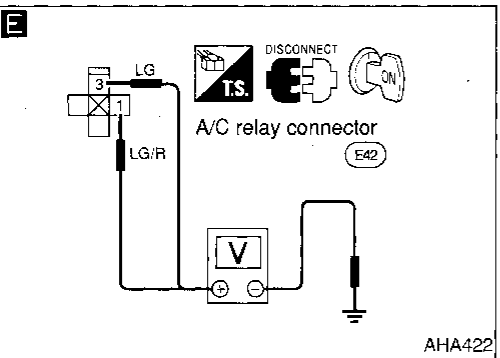
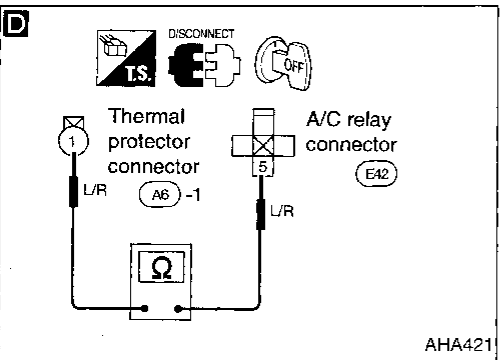
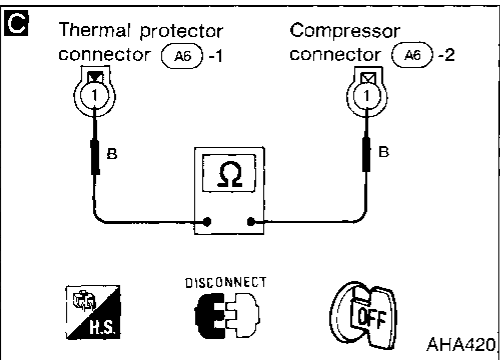
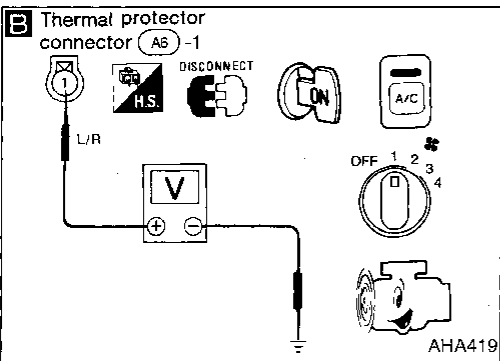
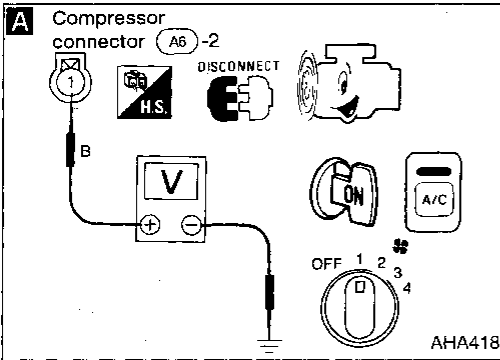

**A**  
CHECK POWER SUPPLY FOR COMPRESSOR.  
Disconnect compressor harness connector.  
Do approx. 12 volts exist between compressor harness terminal ① and body ground?

**B**  
Check magnet clutch coil.  
OK  
Replace magnet clutch. Refer to HA-58.

**B**  
CHECK POWER SUPPLY FOR THERMAL PROTECTOR.  
Disconnect thermal protector harness connector.  
Do approx. 12V exist between thermal protector harness terminal ① and body ground?

**C**  
CHECK THERMAL PROTECTOR.  
Check circuit continuity between thermal protector harness terminal ① and compressor harness terminal ①.  
NG  
Replace thermal protector.

Disconnect A/C relay.

**D** Note  
CHECK CIRCUIT CONTINUITY BETWEEN A/C RELAY HARNESS TERMINAL ⑤ AND THERMAL PROTECTOR HARNESS TERMINAL ①.

**E**  
CHECK POWER SUPPLY FOR A/C RELAY.  
Disconnect A/C relay.  
Do approx. 12 volts exist between A/C relay harness terminals ①, ③ and body ground?

NG  
CHECK POWER SUPPLY CIRCUIT AND 7.5A FUSES AT FUSE BLOCK. Refer to EL section ("Wiring Diagram", "POWER SUPPLY ROUTING").

NG  
CHECK A/C RELAY AFTER DISCONNECTING IT. Refer to HA-49.

Replace A/C relay.

(Go to next page.)

**Note:**  
If the result is NG or No after checking circuit continuity, repair harness or connector.

# TROUBLE DIAGNOSES

## Diagnostic Procedure 3 (Cont'd)

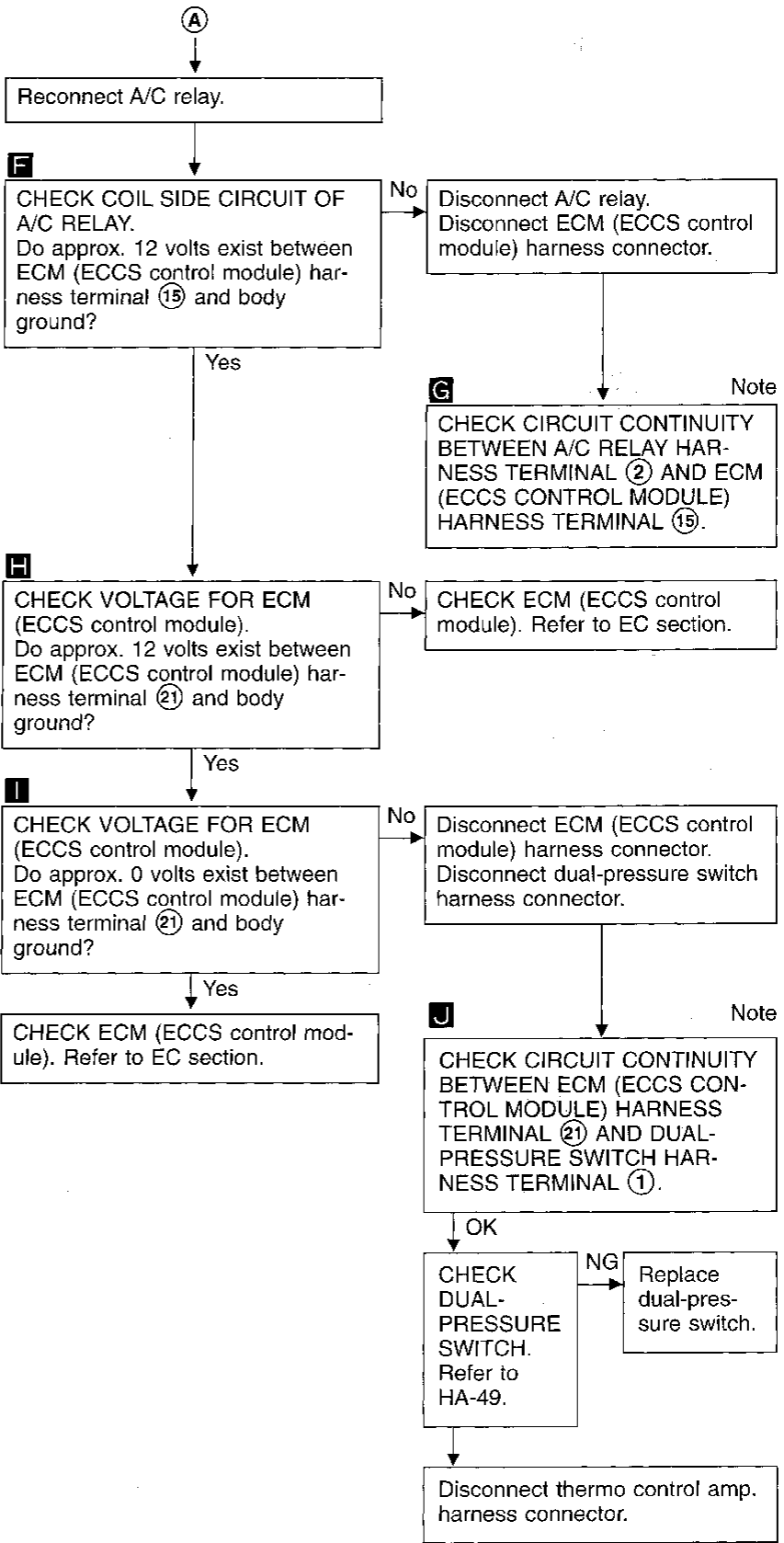
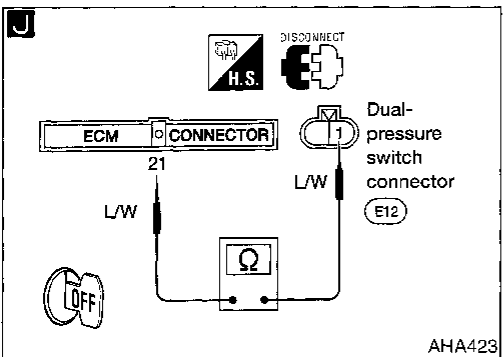
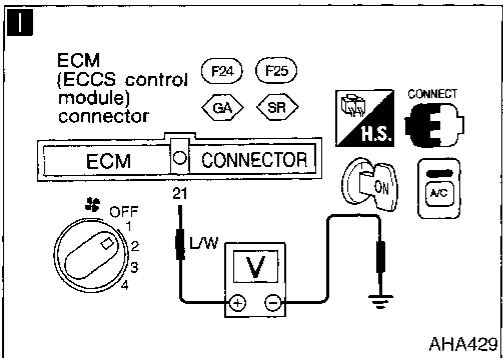
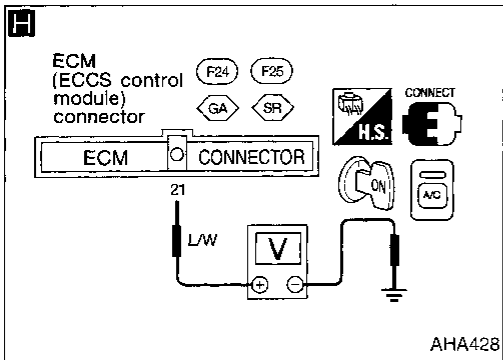
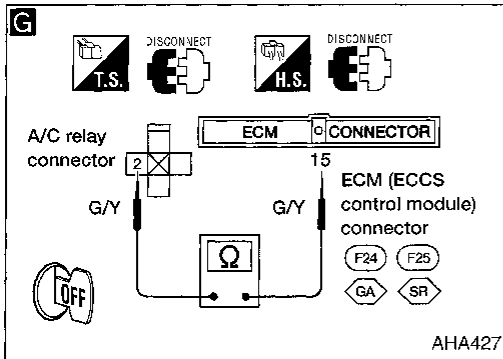
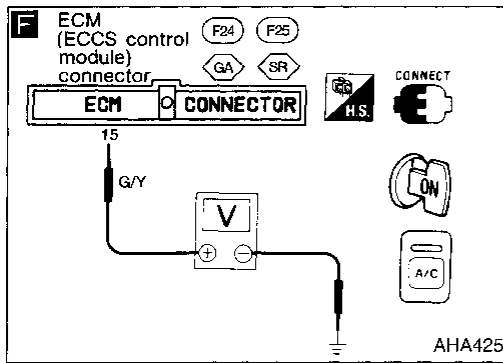

Note:  
If the result is NG or No after checking circuit continuity, repair harness or connector.

(Go to next page.)

# TROUBLE DIAGNOSES

## Diagnostic Procedure 3 (Cont'd)

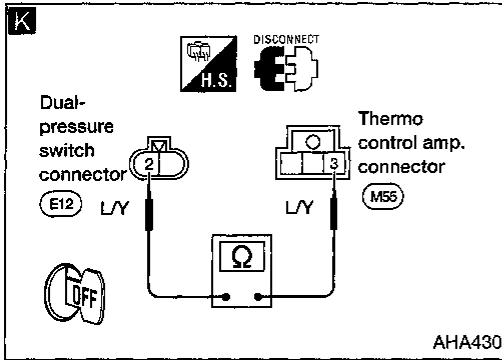

**B**

**K** Note

CHECK CIRCUIT CONTINUITY BETWEEN DUAL-PRESSURE SWITCH HARNESS TERMINAL ② AND THERMO CONTROL AMP. HARNESS TERMINAL ③.

OK

Reconnect dual-pressure switch harness connector.

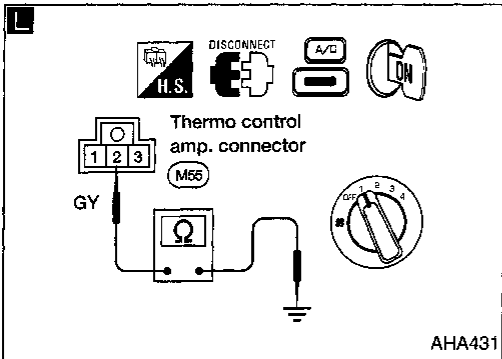

**L** Note

CHECK POWER SUPPLY FOR THERMO CONTROL AMP. Refer to HA-40.

**L**

CHECK BODY GROUND CIRCUIT FOR THERMO CONTROL AMP. Disconnect thermo control amp. harness connector. Does continuity exist between thermo control amp. harness terminal ② and body ground?

Yes

Replace thermo control amp.

No

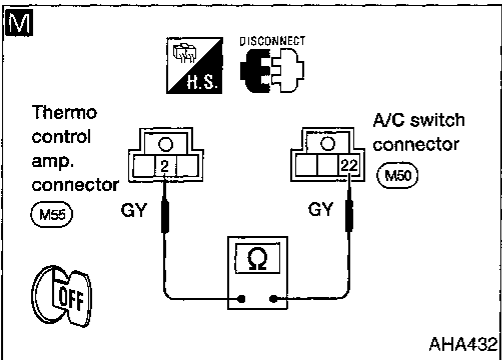

**M** Note

Disconnect A/C switch harness connector.

CHECK CIRCUIT CONTINUITY BETWEEN THERMO CONTROL AMP. HARNESS TERMINAL ② AND A/C SWITCH HARNESS TERMINAL ②②.

OK

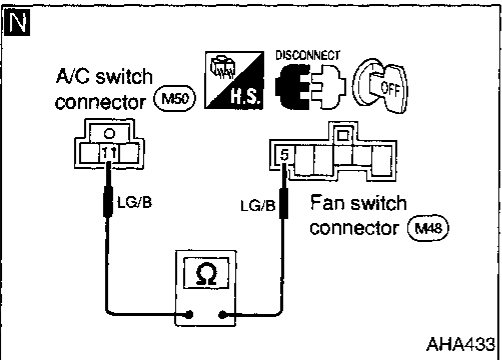

**N** Note

CHECK A/C SWITCH. Refer to HA-48.

NG

Replace A/C switch.

OK

Disconnect fan switch harness connector.

CHECK CIRCUIT CONTINUITY BETWEEN A/C SWITCH HARNESS TERMINAL ①① AND FAN SWITCH HARNESS TERMINAL ⑤.

OK

**C**

(Go to next page.)

**Note:**  
If the result is NG or No after checking circuit continuity, repair harness or connector.

# TROUBLE DIAGNOSES

## Diagnostic Procedure 3 (Cont'd)

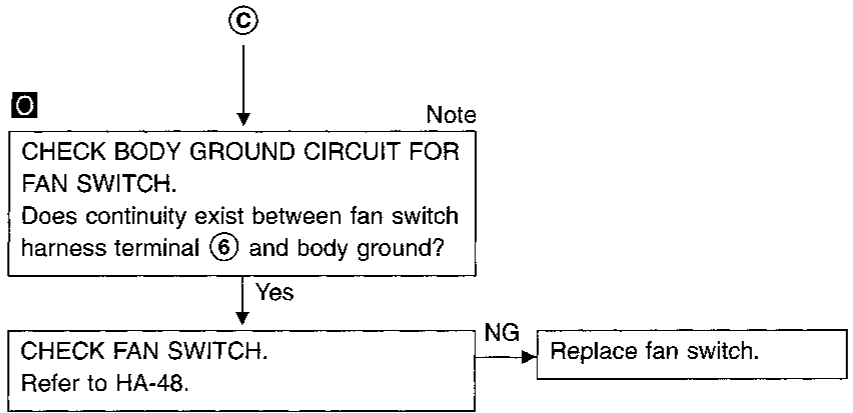
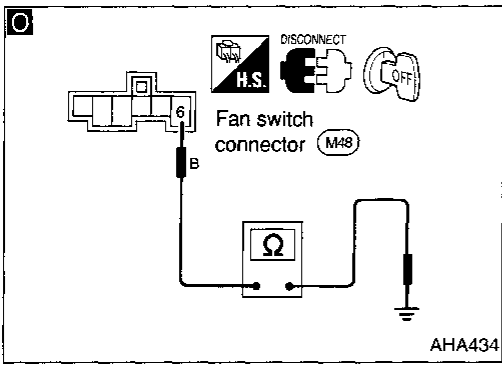

**Note:**

If the result is NG or No after checking circuit continuity, repair harness or connector.

GI  
MA  
EM  
LC  
EC  
FE  
CL  
MT  
AT  
FA  
RA  
BR  
ST  
RS  
BT  
HA  
EL  
IDX



# TROUBLE DIAGNOSES

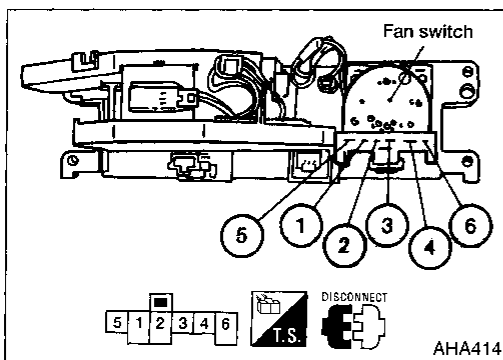

## Electrical Components Inspection

### FAN SWITCH

Check continuity between terminals at each switch position.

TERMINAL	POSITION				
	OFF	1	2	3	4
1					○
2				○	○
3			○		
4		○	○	○	○
5		○	○	○	○
6		○	○	○	○

### BLOWER MOTOR

Confirm smooth rotation of the blower motor.

- Ensure that there are no foreign particles inside the intake unit.

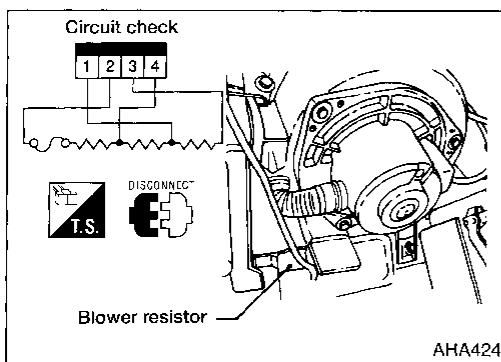

### BLOWER RESISTOR

Check resistance between terminals.

Terminal No.		Resistance
⊕	⊖	
①	②	Approx. 1.4 - 1.6Ω
③		Approx. 2.5 - 2.8Ω
④		Approx. 0.5 - 0.6Ω

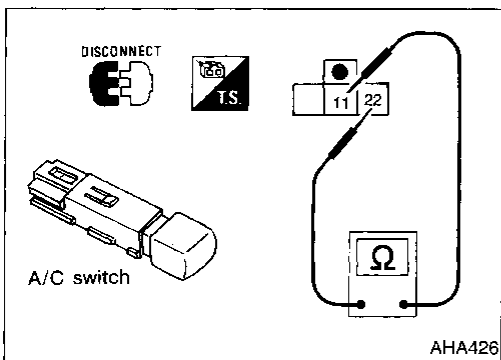

### A/C SWITCH

Check continuity between terminals at each switch position.

Switch condition	Terminal No.		Continuity
	⊕	⊖	
A/C	⑪	⑫	Yes
ON			
OFF			
			No

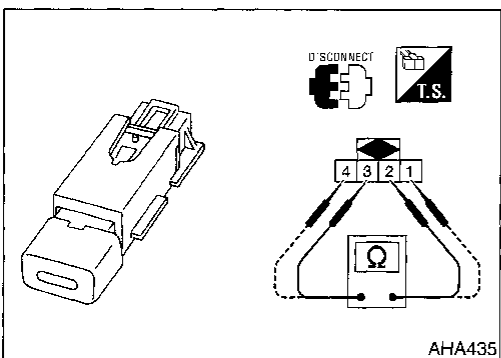

### RECIRC SWITCH

Check continuity between terminals at each switch position.

Terminal No.		RECIRC switch condition	Continuity
⊕	⊖		
③	②	ON	Yes
		OFF	No
④	①	ON	Yes
		OFF	No

# TROUBLE DIAGNOSES

## Electrical Components Inspection (Cont'd)

### THERMAL PROTECTOR

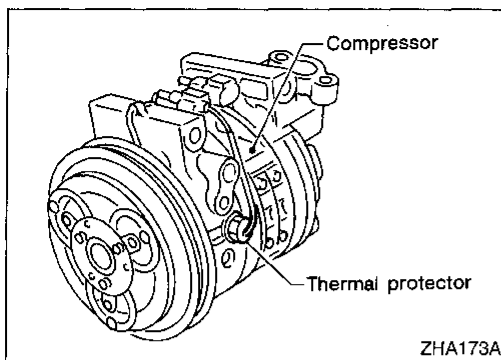

ZHA173A

Temperature of compressor °C (°F)	Compressor operation
Increasing to approx. 145 - 155 (293 - 311)	Turn OFF
Decreasing to approx. 130 - 140 (266 - 284)	Turn ON

GI

MA

EM

LG

EC

FE

CL

MT

AT

FA

RA

BR

ST

RS

BT

HA

EL

IDX

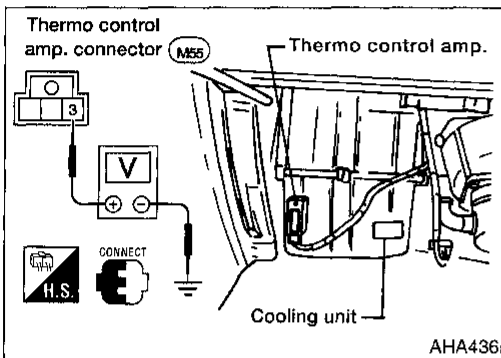

AHA436

### THERMO CONTROL AMP.

1. Run engine, and operate A/C system.
2. Connect the voltmeter from harness side.
3. Check thermo control amp. operation shown in the table.

Evaporator outlet air temperature °C (°F)	Thermo amp. operation	Tester
Decreasing to 2.5 - 3.5 (37 - 38)	Turn OFF	Approx. 12V
Increasing to 4.0 - 5.0 (39 - 41)	Turn On	Approx. 0V

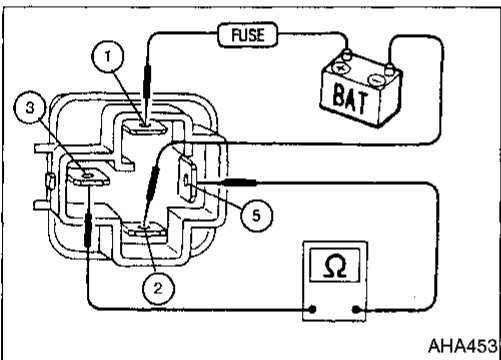

AHA453

### A/C RELAY

Check continuity between terminals ③ and ⑤ .

Conditions	Continuity
12V direct current supply between terminals ① and ②	Yes
No current supply	No

If NG, replace relay.

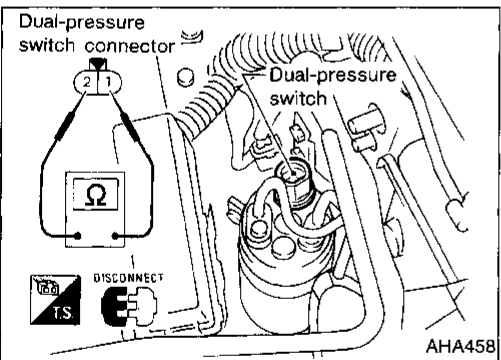

AHA458

### DUAL-PRESSURE SWITCH

	ON Continuity exists kPa (bar, kg/cm <sup>2</sup> , psi)	OFF Continuity does not exist kPa (bar, kg/cm <sup>2</sup> , psi)
Low-pressure side	Increasing to 157 - 216 (1.57 - 2.16, 1.6 - 2.2, 23 - 31)	Decreasing to 157 - 196 (1.57 - 1.96, 1.6 - 2.0, 23 - 28)
High-pressure side	Decreasing to 1,863 - 2,256 (18.6 - 22.6, 19 - 23, 270 - 327)	Increasing to 2,452 - 2,844 (24.5 - 28.4, 25 - 29, 356 - 412)

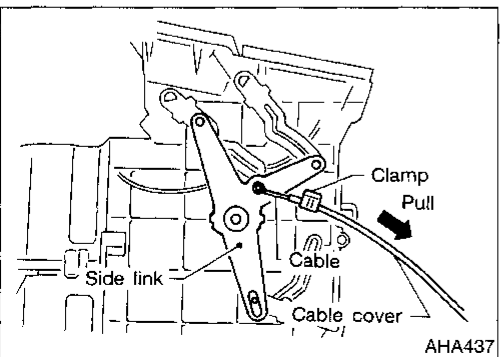

AHA437

### Control Linkage Adjustment

#### MODE CONTROL CABLE

1. Turn the mode control knob to the DEF position.
2. Set the side link in the DEF position by hand.
3. Pull on cable cover in the direction of arrow, then clamp cable cover.

After positioning control cable, check for proper operation.

## TROUBLE DIAGNOSES

### Control Linkage Adjustment (Cont'd)

#### WATER COCK CONTROL ROD

- When adjusting water cock control rod, first disconnect temperature control cable from air mix door lever. Reconnect temperature control cable and readjust it. Refer to "TEMPERATURE CONTROL CABLE.", HA-50.

1. Push air mix door lever in the direction of arrow.
2. Pull control rod in the direction of arrow to a clearance of about 2 mm (0.08 in) between ends of rod and link lever. Connect the rod to door lever.

After connecting control rod, check for proper operation.

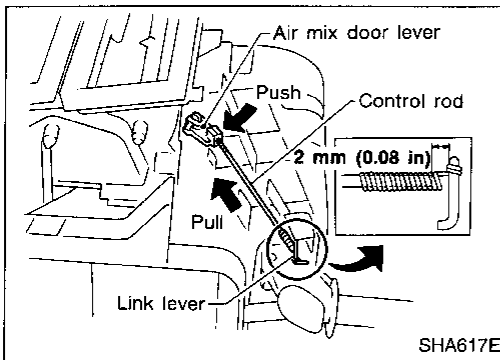

#### TEMPERATURE CONTROL CABLE

1. Move the temperature control knob to the full hot position.
2. Set the air mix door lever in the full hot position.
3. Pull on cable cover in the direction of arrow, then clamp cable cover.

After positioning control cable, check for proper operation.

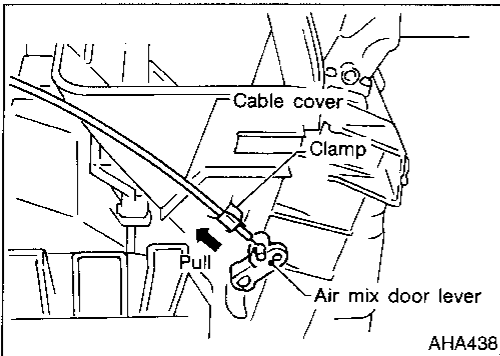

#### INTAKE DOOR MOTOR

1. Install intake door motor on intake unit. Ensure that the intake door motor lever is fitted into the slit portion of intake door link.
2. Connect the intake door motor harness connector.
3. Turn ignition switch to ON.
4. Check that intake door operates properly when REC switch is turned ON and OFF.

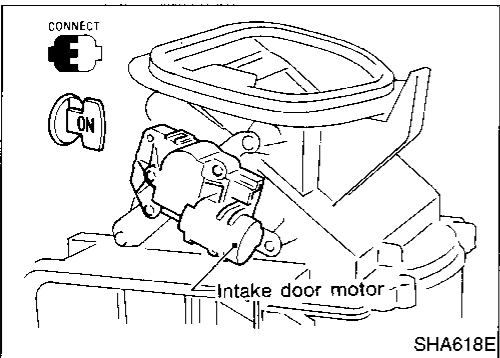

### System Description

#### INTAKE DOOR MOTOR

The intake door motor is installed on the intake unit. Using a link, it opens and closes the intake door.

When REC switch is ON, the ground line of the motor is switched from terminal ② to ④. This starts the motor because the position switch contacts built into it make current flow. When REC switch is OFF, the ground line is switched from terminal ④ to ②. The contacts turn along with the motor. When they reach the non-current flow position, the motor will stop.

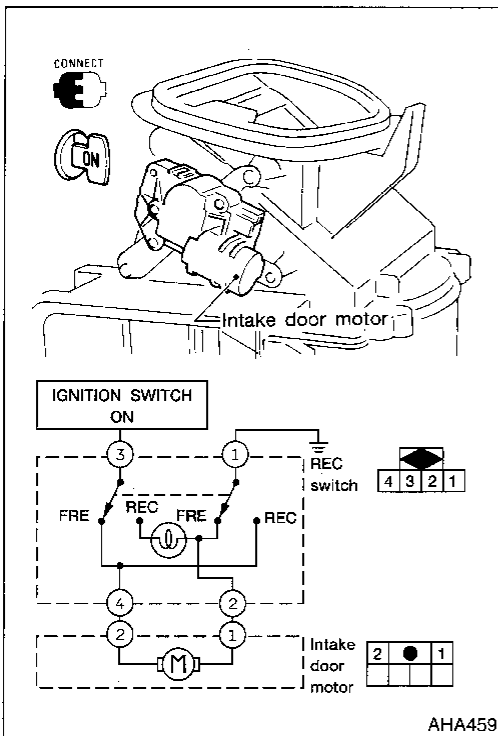

# SERVICE PROCEDURES

## R-134a Service Procedure

### DISCHARGING REFRIGERANT

#### WARNING:

Avoid breathing A/C refrigerant and lubricant vapor or mist. Exposure may irritate eyes, nose and throat. Remove R-134a from the A/C system using certified service equipment meeting requirements of SAE J2210 (R-134a recycling equipment) or J2209 (R-134a recovery equipment). If accidental system discharge occurs, ventilate work area before resuming service. Additional health and safety information may be obtained from refrigerant and lubricant manufacturers.

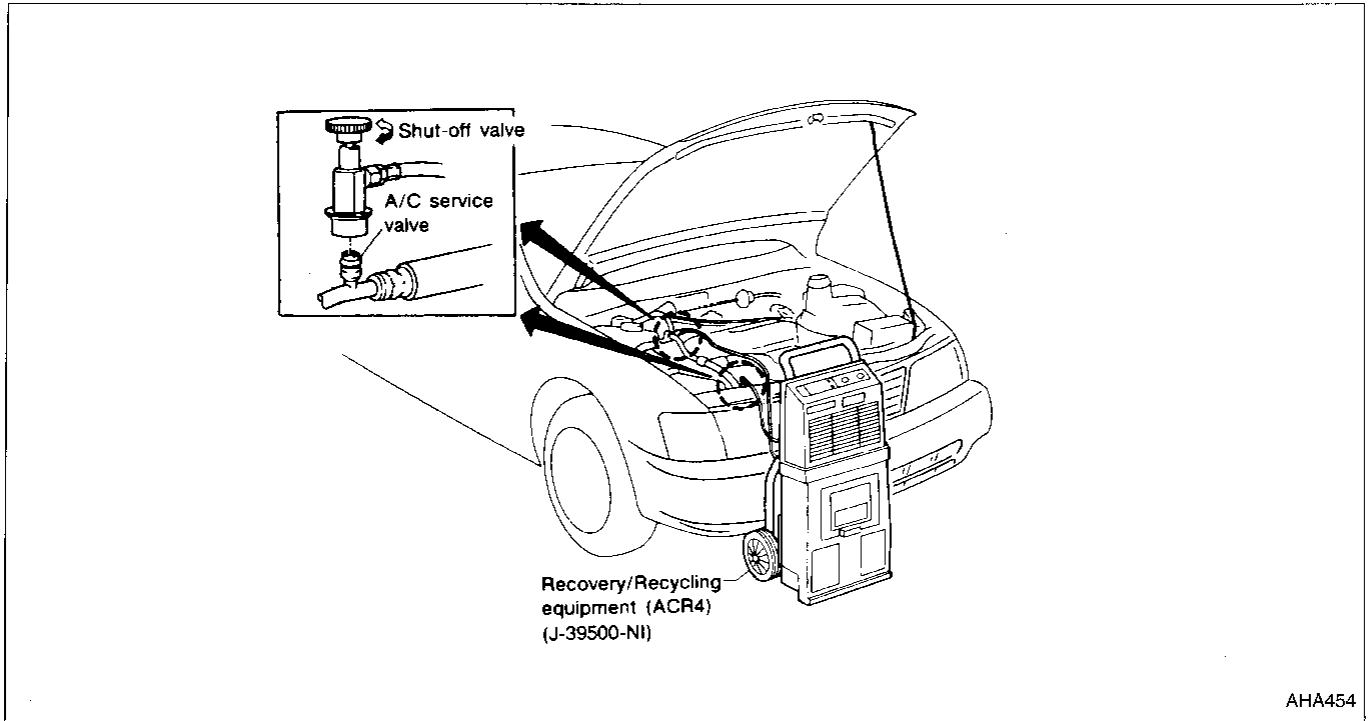

### EVACUATING SYSTEM AND CHARGING REFRIGERANT

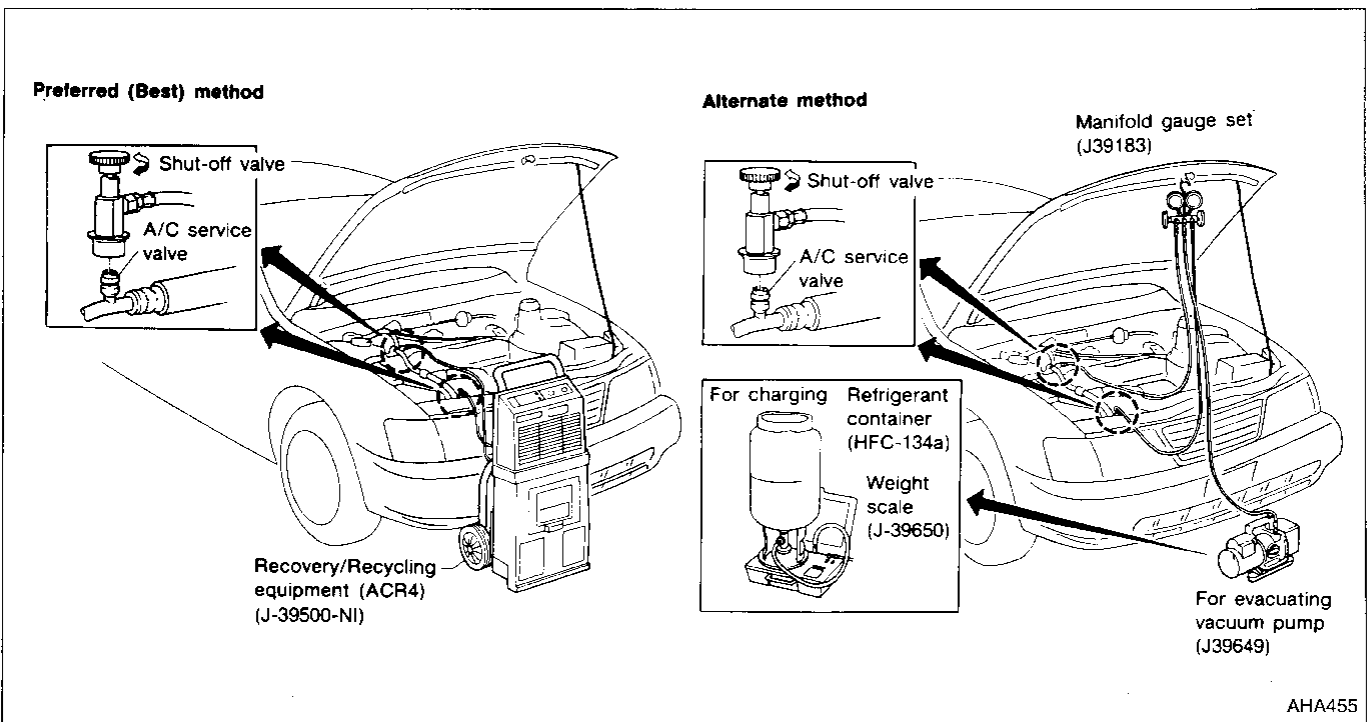

# SERVICE PROCEDURES

## R-134a Service Procedure (Cont'd)

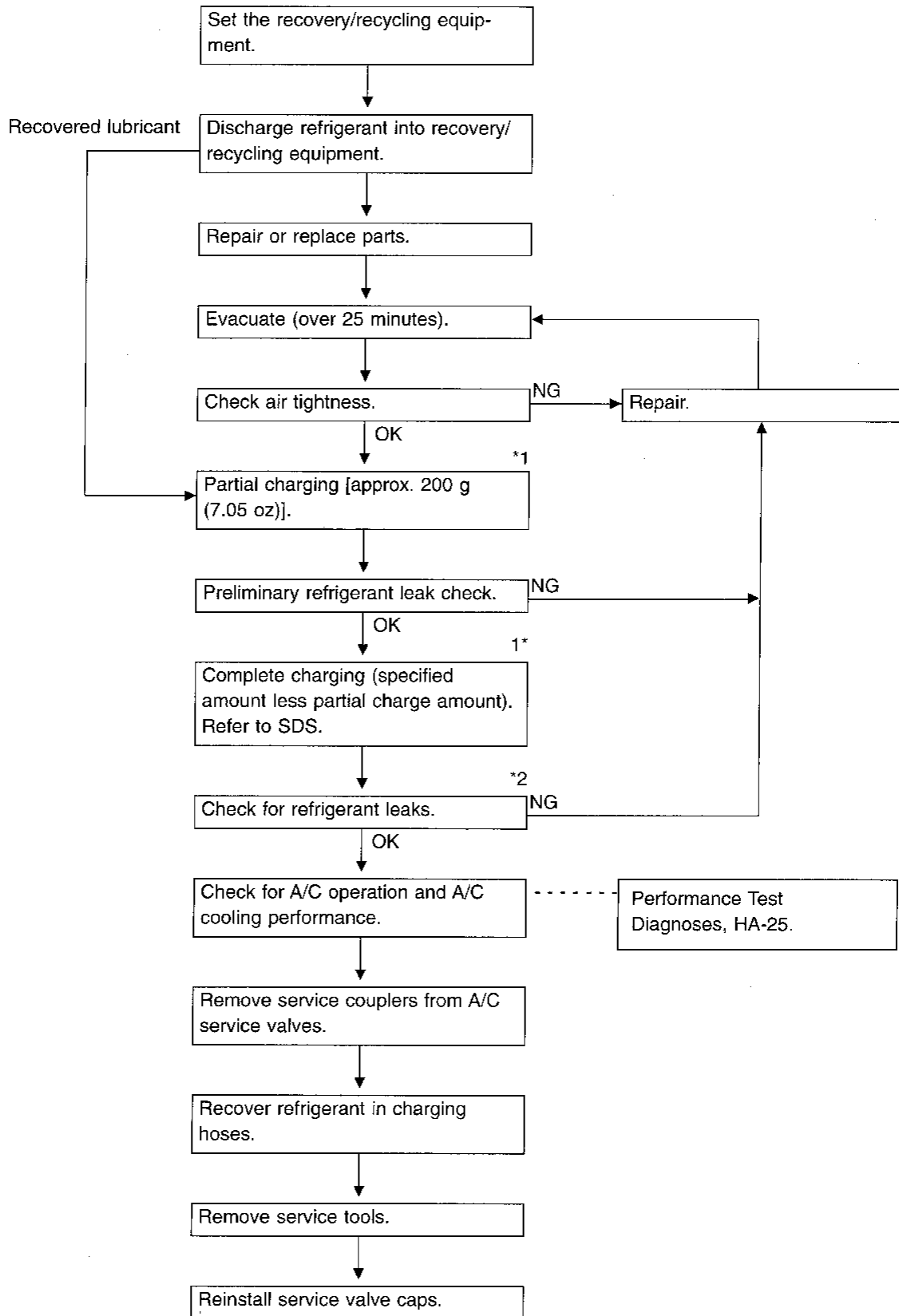

Note: \*1 Before charging refrigerant, ensure engine is off.

\*2 Before checking for leaks, start engine to activate air conditioning system, then turn engine off. Service valve caps must be installed to prevent leakage.

## Compressor Lubricant Quantity

The lubricant used to lubricate the compressor circulates through the system with the refrigerant. Whenever any A/C component is replaced or gas leakage occurs, lubricant must be added.

If lubricant quantity is not maintained properly, the following malfunctions may result:

- Lack of lubricant: May lead to a seized compressor
- Excessive lubricant: Inadequate cooling (thermal exchange interference)

### LUBRICANT

**Name: Nissan A/C System Lubricant Type R**  
**Part No.: KLH00-PAGR0**

### CHECKING AND ADJUSTING

Adjust the lubricant quantity according to the flow chart shown below.

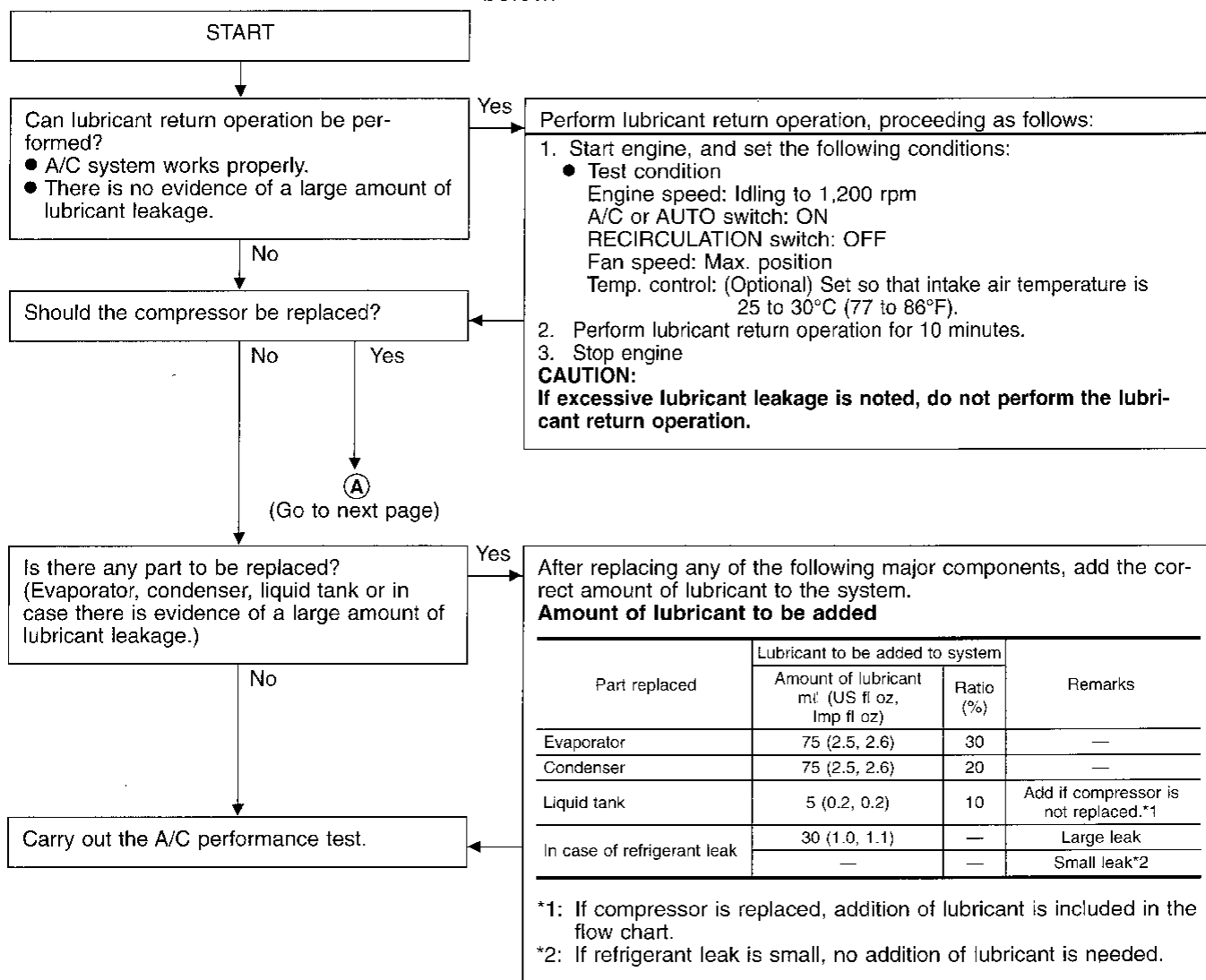

# SERVICE PROCEDURES

## Compressor Lubricant Quantity (Cont'd)

(A)

1. Discharge refrigerant into refrigerant recovery/recycling equipment. Measure oil discharged into the recovery/recycling equipment.
  2. Drain the lubricant from the "old" (removed) compressor into a graduated container and record the amount of lubricant drained.
  3. Drain the lubricant from the "new" compressor into a separate, clean container.
  4. Measure an amount of new lubricant installed equal to amount drained from "old" compressor. Add this lubricant to "new" compressor through the suction port opening.
  5. Measure an amount of "new" lubricant equal to the amount recovered during discharging. Add this lubricant to "new" compressor through the suction port opening.
  6. If the liquid tank also needs to be replaced, add an additional 5 ml (0.2 US fl oz, 0.2 Imp fl oz) of lubricant at this time.
- Do not add this 5 ml (0.2 US fl oz, 0.2 Imp fl oz) of lubricant if only replacing the compressor.**

### Lubricant adjusting procedure for compressor replacement

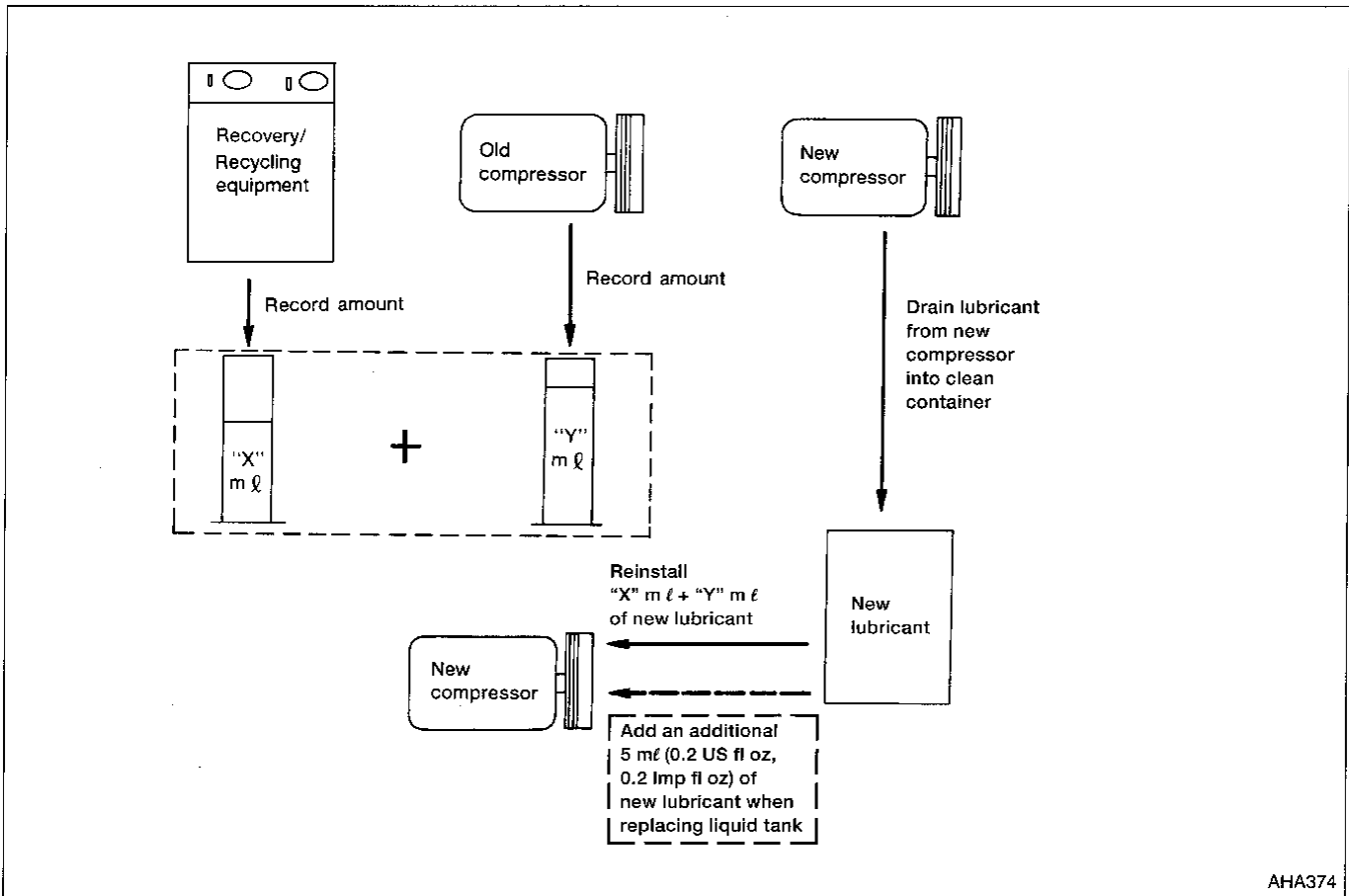

# SERVICE PROCEDURES

## Refrigerant Lines

- Refer to "Precautions for Refrigerant Connection", HA-4.

### GA16DE ENGINE MODEL

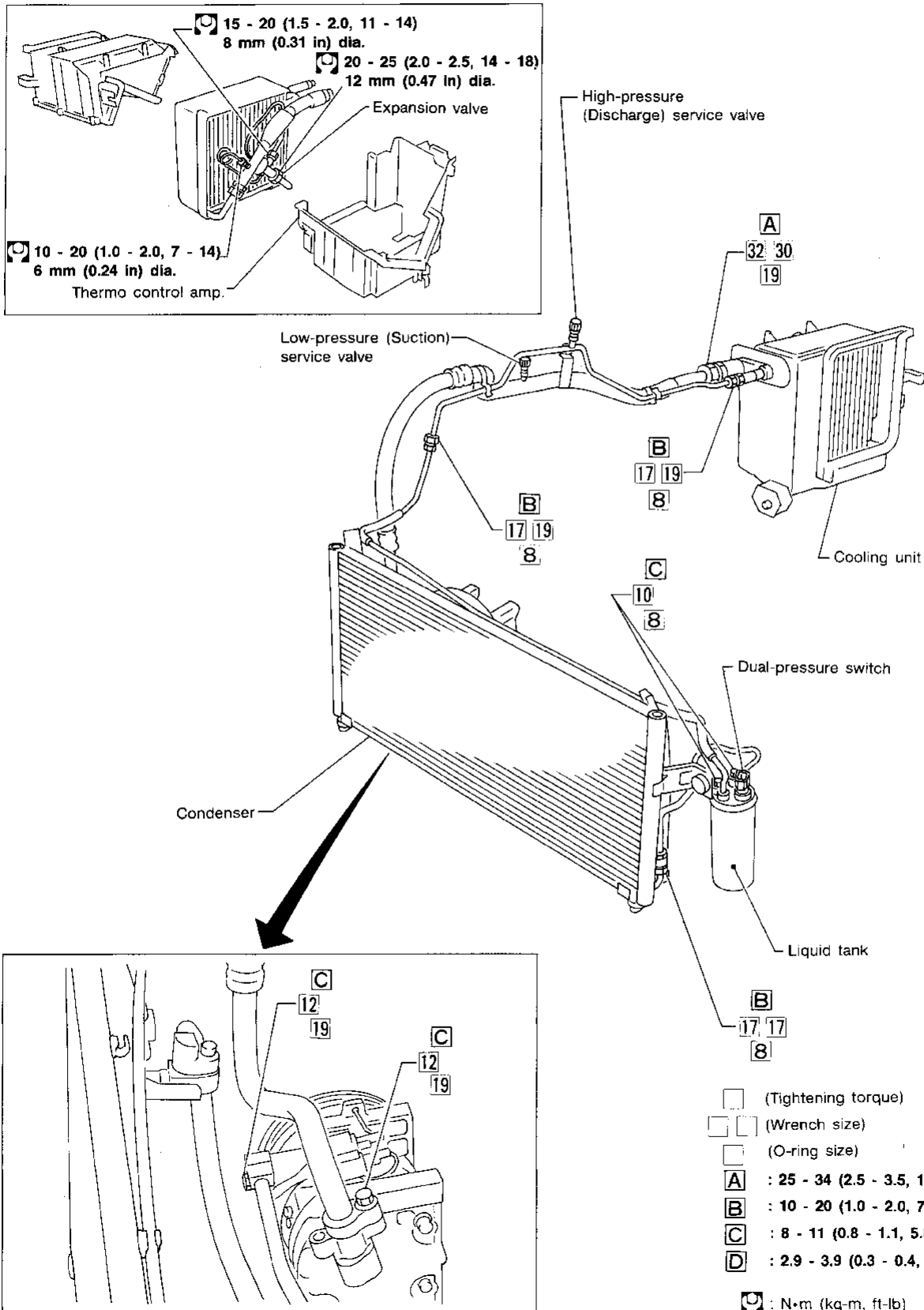

GI  
WA  
EM  
LC  
EC  
FE  
CL  
MT  
AT  
FA  
RA  
BR  
ST  
RS  
BT

**HA**

EL  
DX

RHA633E



# SERVICE PROCEDURES

## Refrigerant Lines (Cont'd)

### SR20DE ENGINE MODEL

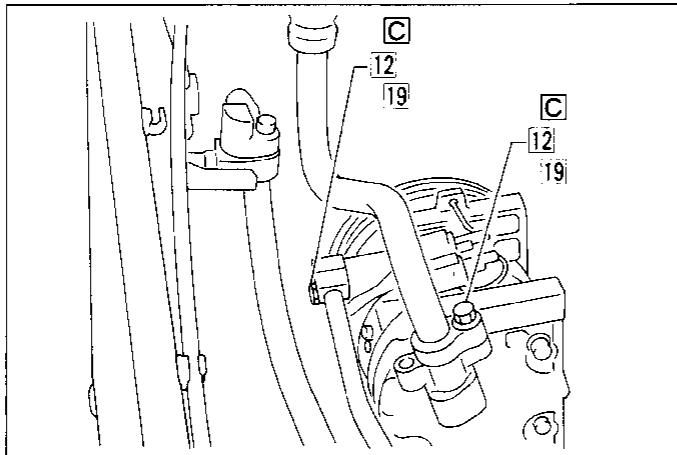
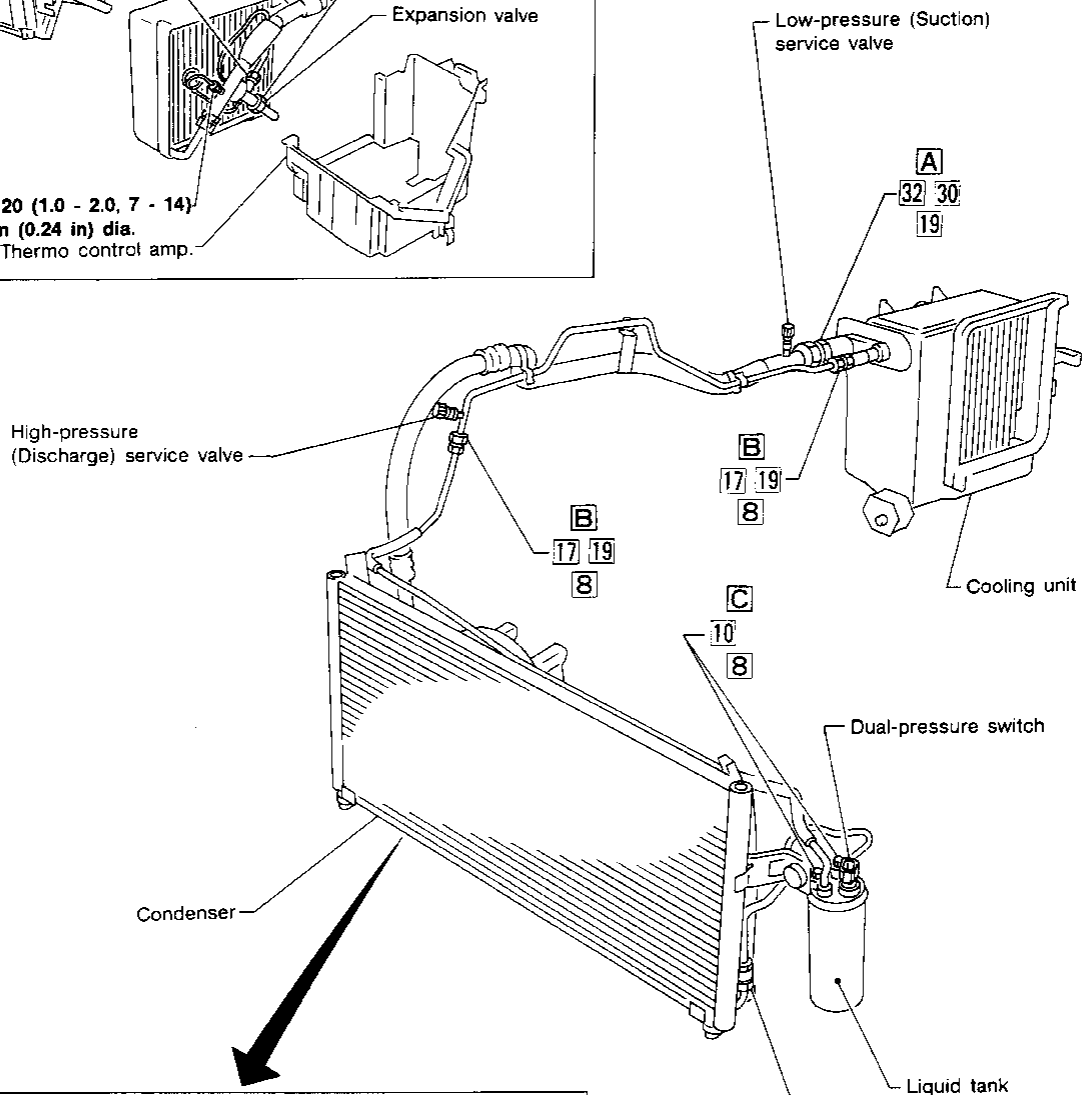
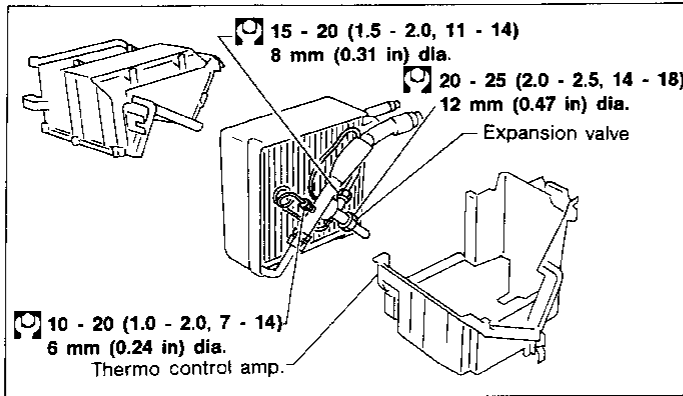

- (Tightening torque)
- (Wrench size)
- (O-ring size)
- A : 25 - 34 (2.5 - 3.5, 18 - 25)
- B : 10 - 20 (1.0 - 2.0, 7 - 14)
- C : 8 - 11 (0.8 - 1.1, 5.8 - 8.0)
- D : 2.9 - 3.9 (0.3 - 0.4, 2.2 - 2.9)
- Ⓜ : N·m (kg·m, ft·lb)

AHA384

## Compressor Mounting

GA16DE engine models  
SEC. 274 • 275

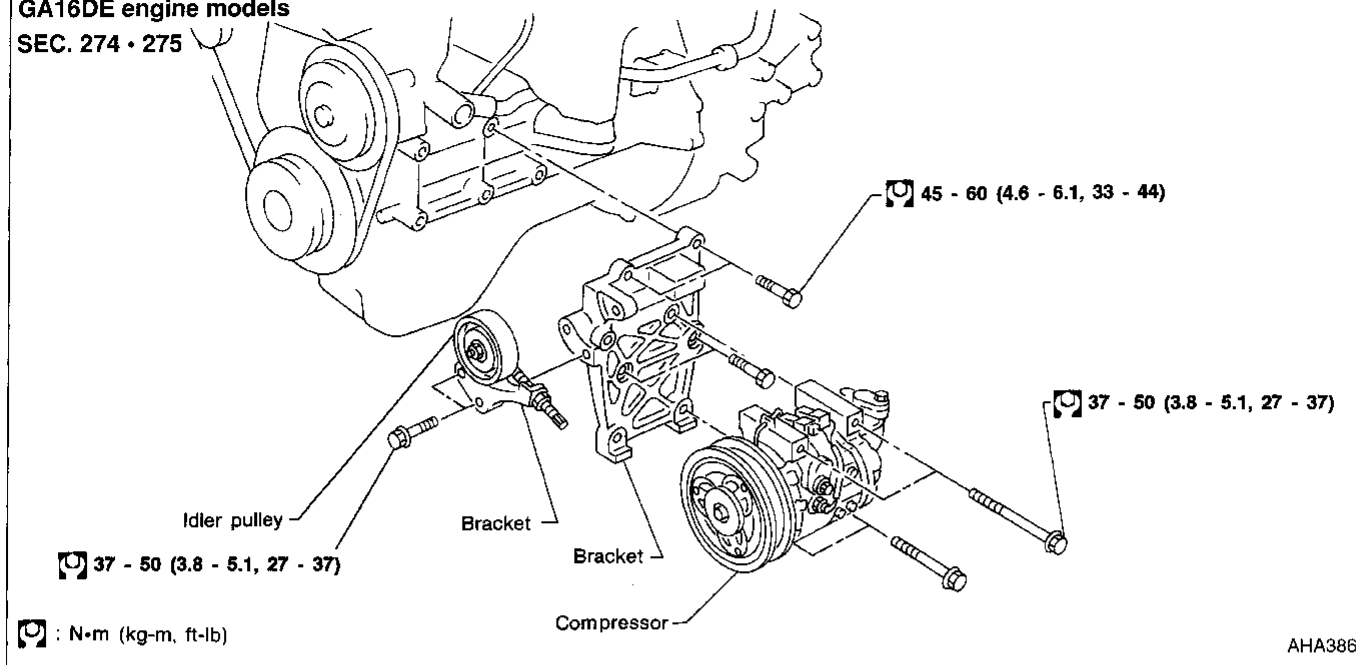

SR20DE engine models  
SEC. 274 • 275

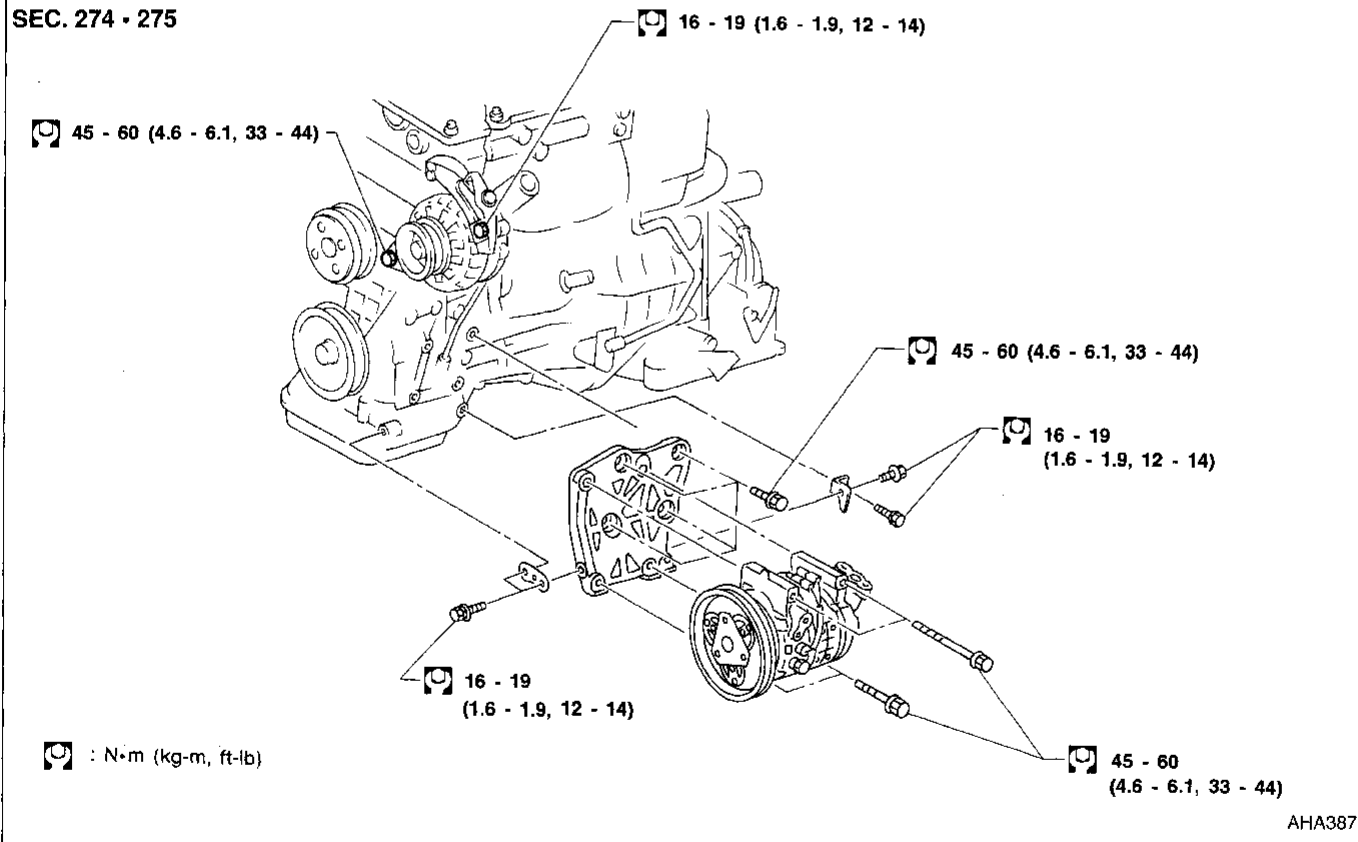

### Belt Tension

- Refer to MA section, (“Checking Drive Belts”, “ENGINE MAINTENANCE”).

### Fast Idle Control Device (FICD)

- Refer to EC section (“IACV-FICD Solenoid Valve”, “TROUBLE DIAGNOSIS FOR NON-DETECTABLE ITEMS”).

GI  
MA  
EM  
LC  
EC  
FE  
CL  
MT  
AT  
FA  
RA  
BR  
ST  
RS  
BT  
HA  
EL

IDX

## Compressor

SEC. 274

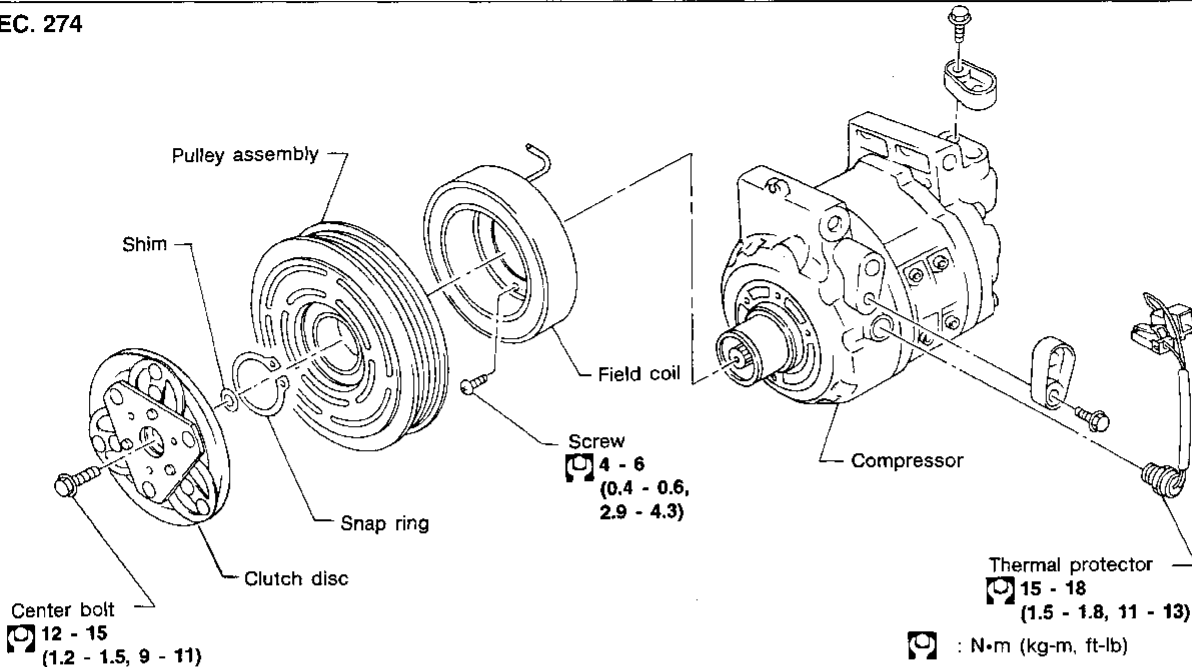

AHA388

## Compressor Clutch

### REMOVAL

- When removing center bolt, hold clutch disc with clutch disc wrench.
- Remove the drive plate using the clutch disc puller. Insert holder's three pins into the drive plate. Rotate the holder clockwise to hook it onto the plate. Tighten the center bolt to remove the drive plate. While tightening the center bolt, insert a screwdriver between two of the pins (as shown in the figure) to prevent rotation. After removing the drive plate, remove the shims from either the drive shaft or the drive plate.
- Remove the snap ring using external snap ring pliers.

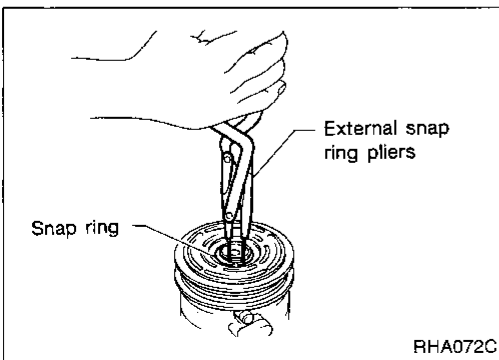
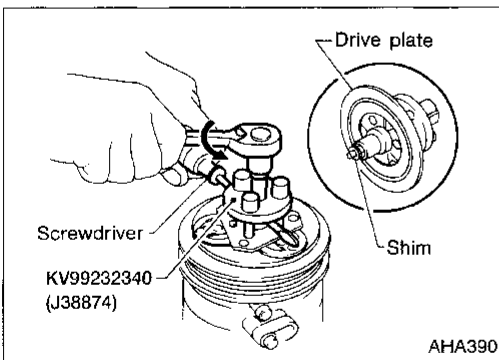
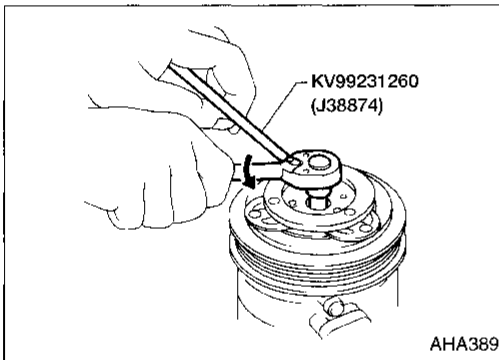

# SERVICE PROCEDURES

## Compressor Clutch (Cont'd)

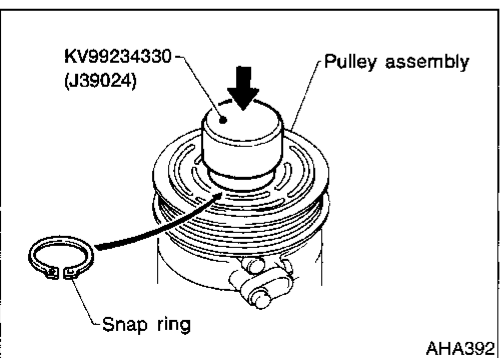
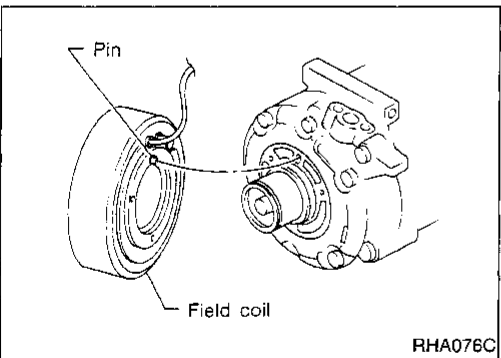
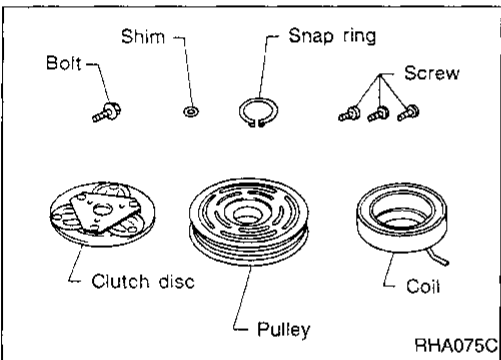
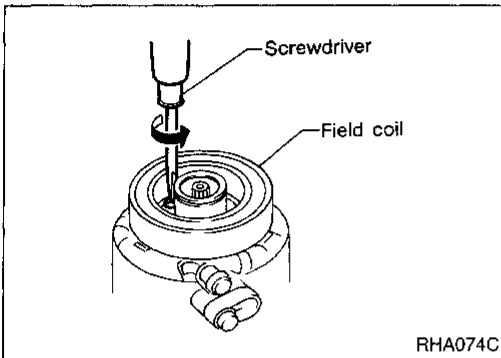
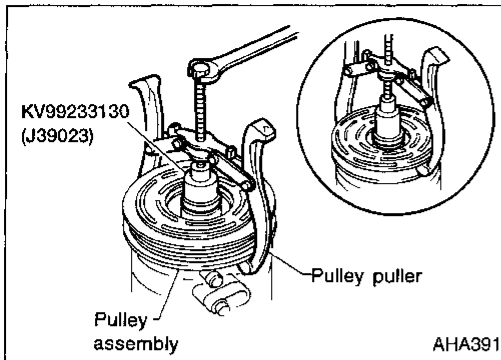

- Pulley removal:  
Use a commercially available pulley puller. Position the center of the puller on the end of the drive shaft. Remove the pulley assembly with the puller.

### For pressed pulleys:

To prevent deformation of the pulley groove, the puller claws should be hooked under (not into) the pulley groove.

### For machine latched pulleys:

Align the pulley puller groove with the pulley groove, and then remove the pulley assembly.

- Remove the field coil harness clip using a screwdriver.
- Remove the three field coil fixing screws and remove the field coil.

## INSPECTION

**Clutch disc:** If the contact surface shows signs of damage due to excessive heat, replace clutch disc and pulley.

**Pulley:** Check the appearance of the pulley assembly. If contact surface of pulley shows signs of excessive grooving, replace clutch disc and pulley. The contact surfaces of the pulley assembly should be cleaned with a suitable solvent before reinstallation.

**Coil:** Check coil for loose connection or cracked insulation.

## INSTALLATION

- Install the field coil.  
**Be sure to align the coil pin with the hole in the compressor front head.**
- Install the field coil harness clip using a screwdriver.

- Install the pulley assembly using the installer and a hand press, and then install the snap ring using snap ring pliers.

## SERVICE PROCEDURES

### Compressor Clutch (Cont'd)

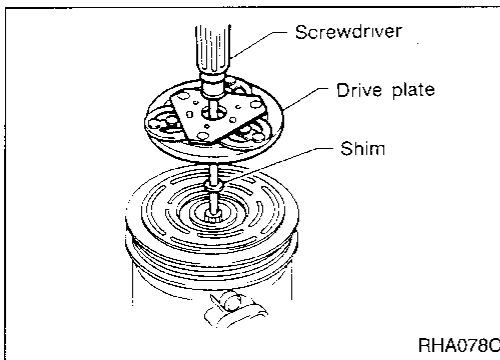

- Install the drive plate on the drive shaft, together with the original shim(s). Press the drive plate down by hand.

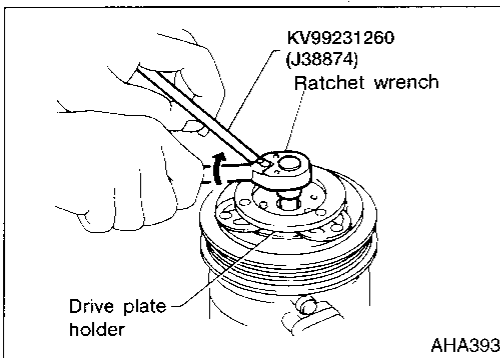

- Using the holder to prevent drive plate rotation, tighten the bolt to 12 to 15 N·m (1.2 to 1.5 kg-m, 9 to 11 ft-lb) torque.
- **After tightening the bolt, check that the pulley rotates smoothly.**

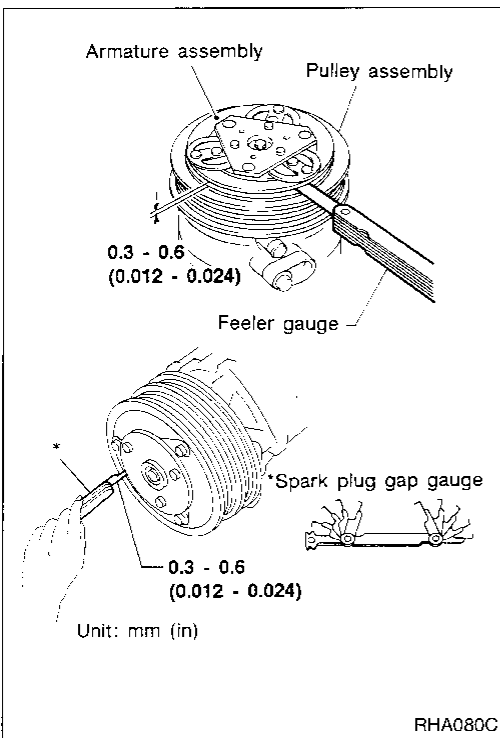

- Check clearance all the way around the clutch disc.

#### Disc-to-pulley clearance:

**0.3 - 0.6 mm (0.012 - 0.024 in)**

If the specified clearance is not obtained, replace adjusting spacer and readjust.

### BREAK-IN OPERATION

When replacing compressor clutch assembly, always conduct the break-in operation. This is done by engaging and disengaging the clutch about thirty times. Break-in operation raises the level of transmitted torque.

### Thermal Protector

#### INSPECTION

- When servicing, do not allow foreign matter to get into compressor.
- Check continuity between two terminals.

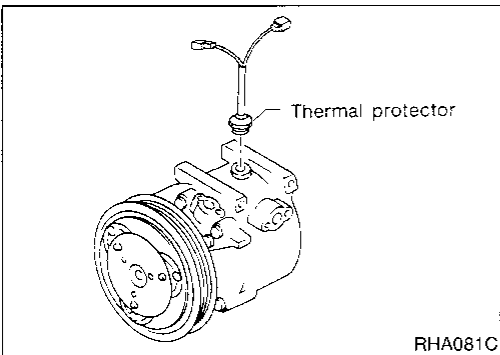

## Heater Unit

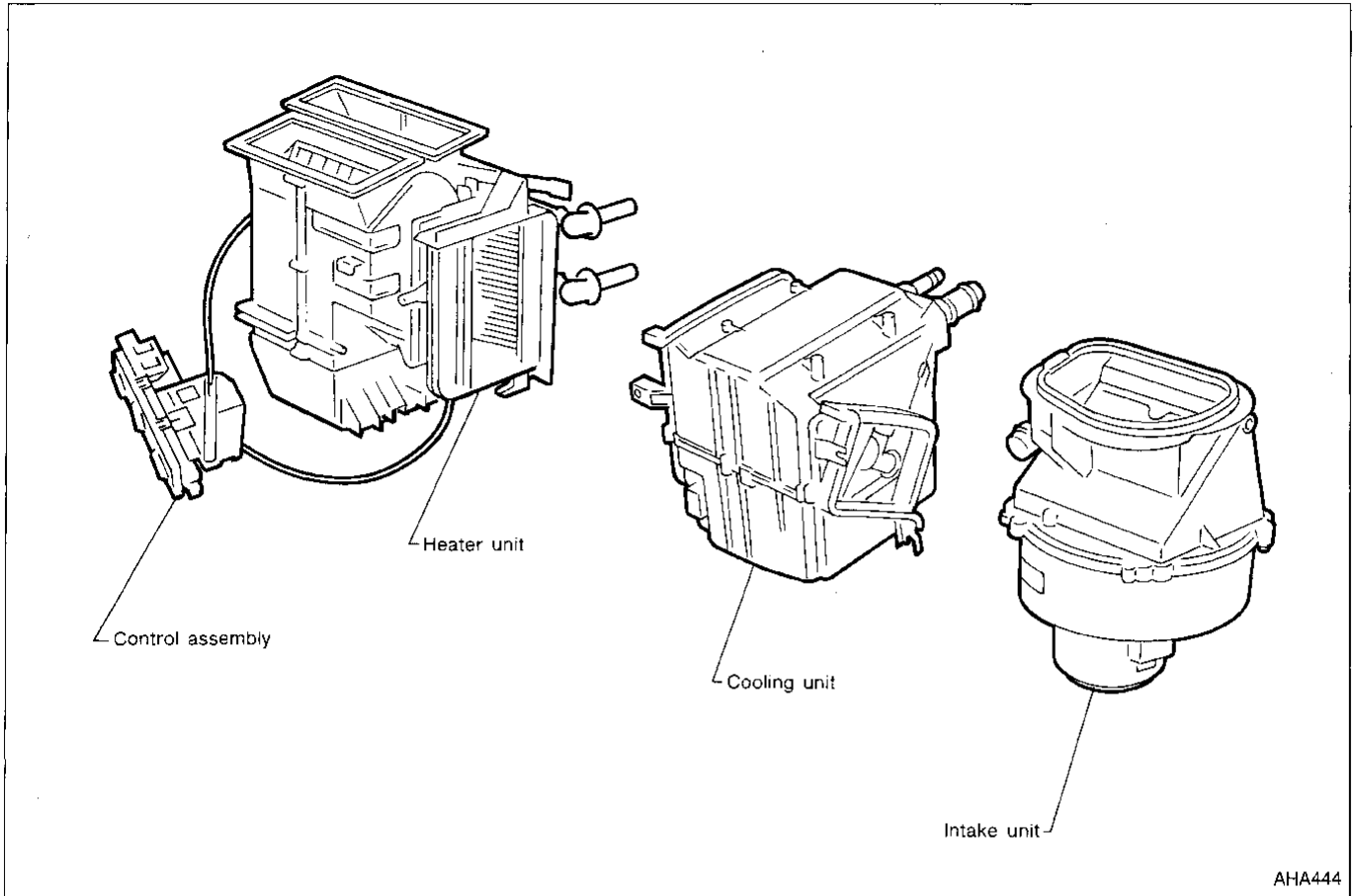

### REMOVAL

- Heater unit is not a serviceable component.
1. Drain cooling system. Refer to MA section ("Draining Engine Coolant", "ENGINE MAINTENANCE").
  2. Discharge the A/C system. Refer to "DISCHARGE REFRIGERANT", HA-51.
  3. Remove the instrument panel. Refer to BT section ("INSTRUMENT PANEL").

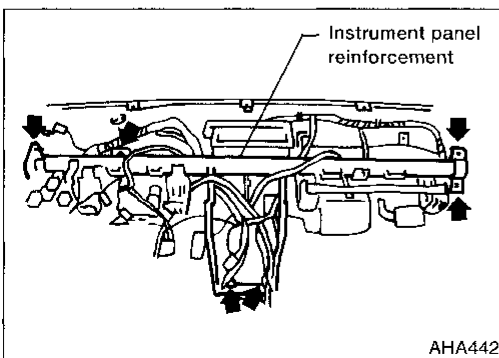

4. Remove the instrument panel reinforcement.
5. Remove the cooling unit.

CI  
MA  
EM  
LC  
EC  
FE  
CL  
MT  
AT  
FA  
RA  
BR  
ST  
RS  
BT  
HA  
EL  
IDX

## SERVICE PROCEDURES

### Heater Unit (Cont'd)

6. Remove the heater unit.

### INSTALLATION

Installation is the reverse of removal. Inspect cooling for leaks. Inspect A/C system for refrigerant leaks.

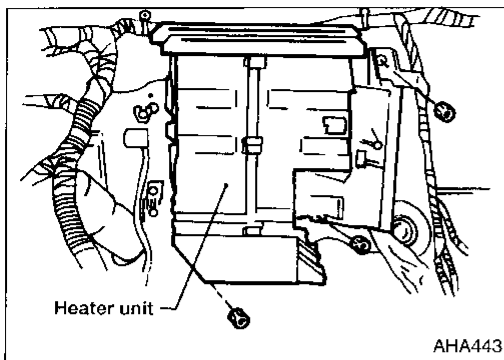

### Cooling Unit

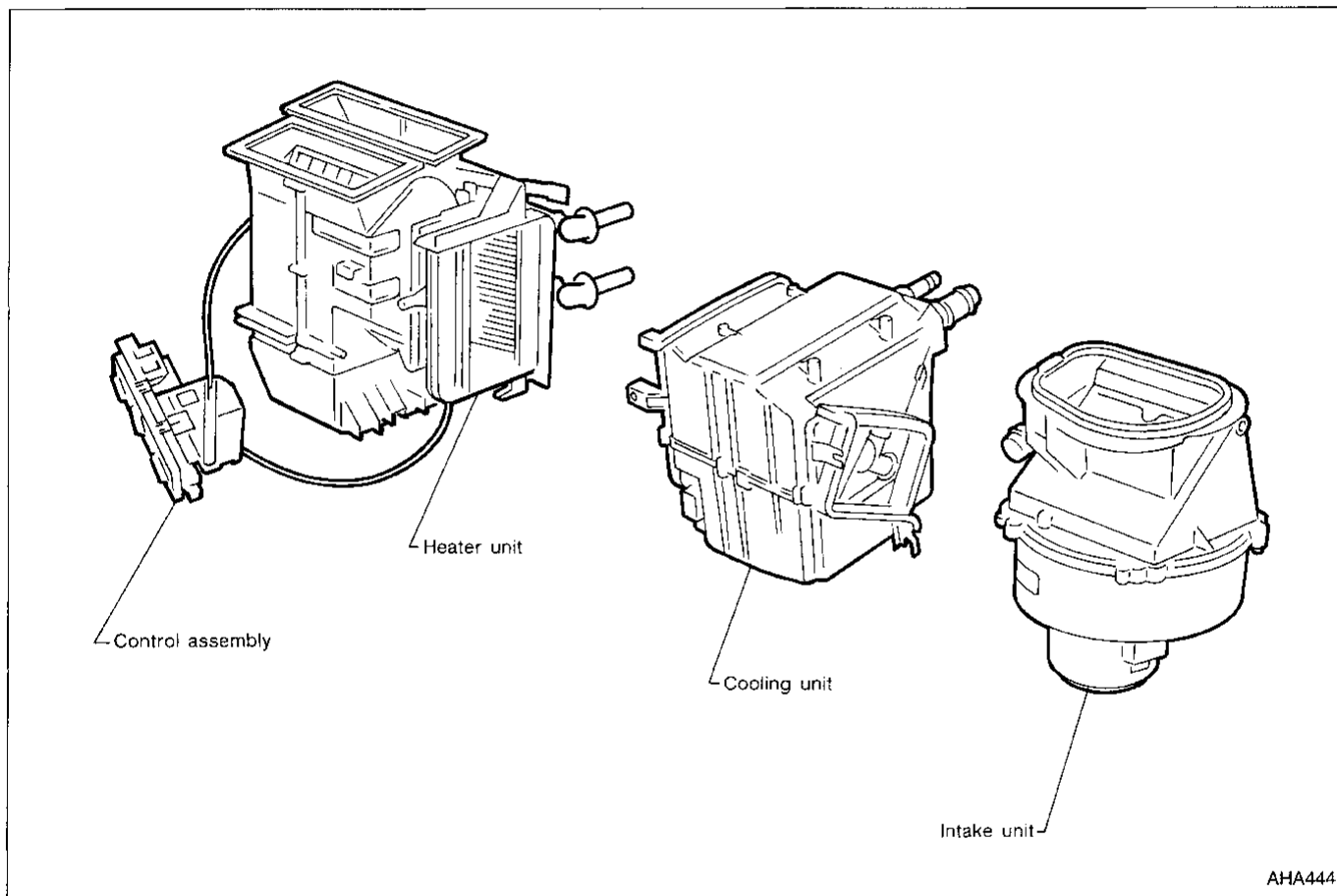

### REMOVAL

- Cooling unit is not a serviceable unit.
1. Discharge the A/C system. Refer to "DISCHARGING REFRIGERANT, HA-51.
  2. Remove the instrument panel. Refer to BT section ("INSTRUMENT PANEL").

# SERVICE PROCEDURES

## Cooling Unit (Cont'd)

3. Remove the cooling unit.

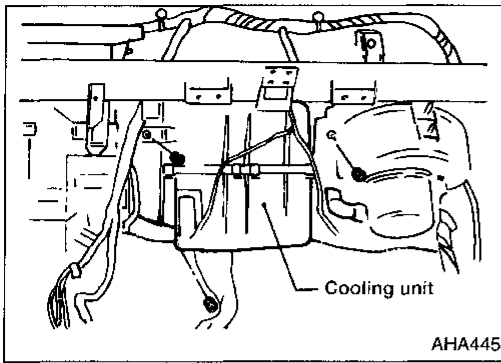

## INSTALLATION

Installation is the reverse of removal. Inspect A/C system for refrigerant leaks.

## Control Assembly

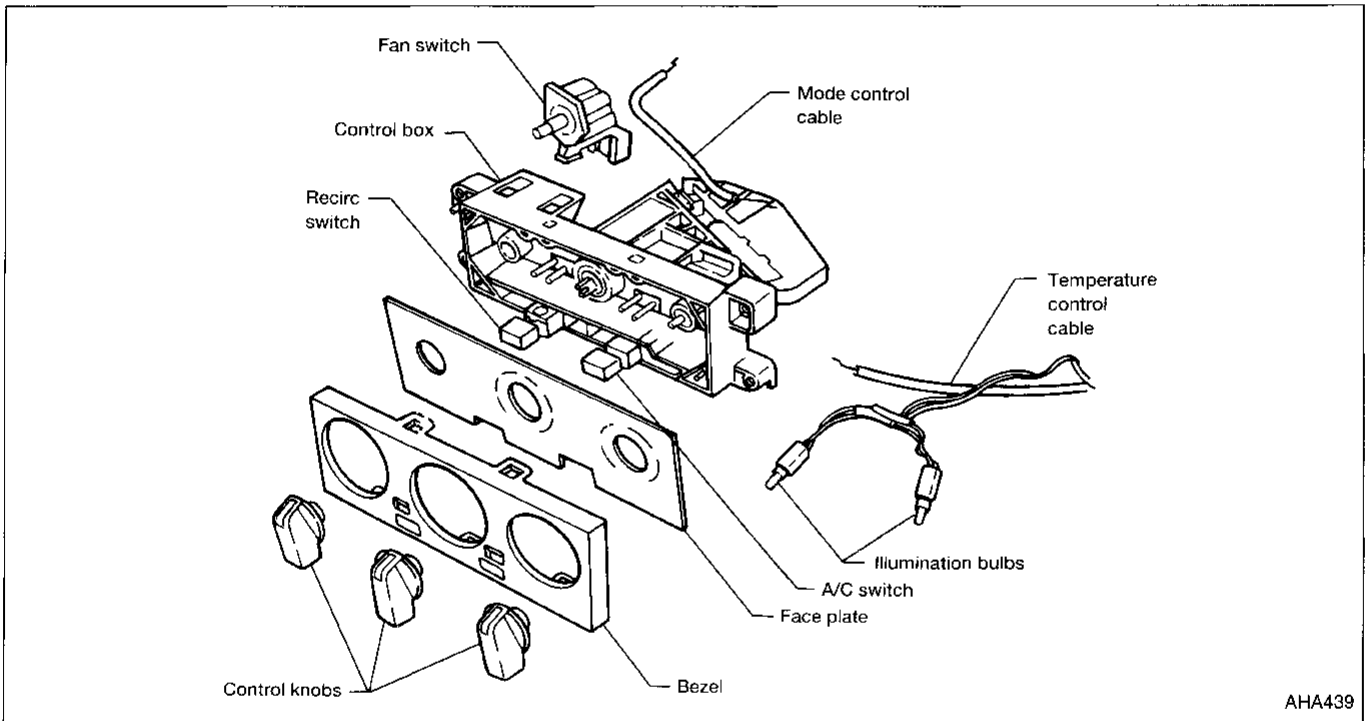

CI

MA

EM

LC

EC

FE

CL

MT

AT

FA

RA

BR

ST

RS

BT

HA

EL

IDX



# SERVICE DATA AND SPECIFICATIONS (SDS)

## General Specifications

### COMPRESSOR

Model	DKV-14D
Type	Vane rotary
Displacement cm <sup>3</sup> (cu in)/Rev	140 (8.54)
Direction of rotation	Clockwise (Viewed from drive end)
Drive belt	Poly V type

### LUBRICANT

Model	ZEXEL make DKV-14D
Name	Nissan A/C System Lubricant Type R
Part number	KLH00-PAGR0
Capacity ml (US fl oz, Imp fl oz)	
Total in system	200 (6.8, 7.0)
Compressor (Service parts) charging amount	200 (6.8, 7.0)

### REFRIGERANT

Type	HFC-134a (R-134a)
Capacity kg (lb)	0.60 - 0.70 (1.32 - 1.54)

## Inspection and Adjustment

### ENGINE IDLE SPEED

When A/C is ON

- Refer to EC section ("Inspection and Adjustment", "SERVICE DATA AND SPECIFICATIONS").

### BELT TENSION

- Refer to MA section ("Checking Drive Belts", "ENGINE MAINTENANCE").

### COMPRESSOR

Model	DKV-14D
Clutch disc-to-pulley clearance mm (in)	0.3 - 0.6 (0.012 - 0.024)