

SECTION **CL**

GI

MA

EM

LC

EC

FE

CL

MT

AT

FA

RA

BR

ST

RS

BT

HA

EL

IDX

CONTENTS

PRECAUTIONS AND PREPARATION	2	CLUTCH RELEASE MECHANISM	6
Precaution	2	CLUTCH DISC AND CLUTCH COVER	7
Special Service Tools.....	2	Clutch Disc.....	7
NOISE, VIBRATION AND HARSHNESS (NVH)		Clutch Cover and Flywheel.....	8
TROUBLESHOOTING	3	SERVICE DATA AND SPECIFICATIONS (SDS)	9
NVH Troubleshooting Chart.....	3	General Specifications	9
CLUTCH SYSTEM	4	Inspection and Adjustment.....	9
INSPECTION AND ADJUSTMENT	5		
Adjusting Clutch Pedal.....	5		

PRECAUTIONS AND PREPARATION



Precaution

WARNING:

After cleaning the clutch disc, wipe it with a dust collector.
Do not use compressed air.

Special Service Tools

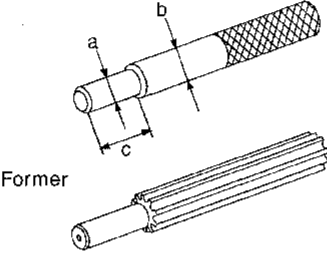
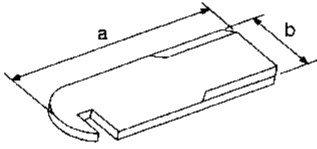
The actual shapes of Kent-Moore tools may differ from those of special service tools illustrated here.

Tool number (Kent-Moore No.) Tool name	Description
KV30101600 (New) KV30101000 (Former) (J33213) Clutch aligning bar	<div style="display: flex; justify-content: space-between;"> <div data-bbox="565 617 607 638">New</div> <div data-bbox="1008 604 1393 625">Installing clutch cover and clutch disc</div> </div>  <div style="display: flex; justify-content: space-between; margin-top: 10px;"> <div data-bbox="565 827 634 848">Former</div> <div data-bbox="1008 856 1284 947"> <p>a: 15.9 mm (0.626 in) dia. b: 17.9 mm (0.705 in) dia. c: 40 mm (1.57 in)</p> </div> </div> <div data-bbox="440 919 496 940">NT645</div>
ST20050240 (—) Diaphragm spring adjusting wrench	<div style="display: flex; justify-content: space-between;"> <div data-bbox="553 982 867 1129">  </div> <div data-bbox="1008 972 1458 1024">Adjusting unevenness of diaphragm spring of clutch cover</div> </div> <div style="display: flex; justify-content: space-between; margin-top: 10px;"> <div data-bbox="440 1140 496 1161">NT404</div> <div data-bbox="1008 1108 1214 1161"> <p>a: 150 mm (5.91 in) b: 25 mm (0.98 in)</p> </div> </div>
KV32101000 (J25689-A) Pin punch	<div style="display: flex; justify-content: space-between;"> <div data-bbox="639 1203 797 1287">  </div> <div data-bbox="1008 1192 1357 1213">Removing and installing spring pin</div> </div> <div style="display: flex; justify-content: space-between; margin-top: 10px;"> <div data-bbox="440 1308 496 1329">NT410</div> <div data-bbox="1008 1308 1230 1329"> <p>a: 4 mm (0.16 in) dia.</p> </div> </div>

NOISE, VIBRATION AND HARSHNESS (NVH) TROUBLESHOOTING

NVH Troubleshooting Chart

Use the chart below to help you find the cause of the problem. The numbers indicate the priority of the likely cause of the problem. Check each part in order. If necessary, repair or replace these parts.

Reference page		CL-5	CL-6	CL-7	CL-7	CL-7	CL-7	CL-7	CL-7	CL-7	CL-7	CL-8	CL-8	CL-8	CL-8	
Parts name		Clutch pedal (Free play out of adjustment)	Engine mounting (Loose)	Release bearing (Worn, dirty or damaged)	Clutch disc (Out of true)	Clutch disc (Runout is excessive)	Clutch disc (Lining broken)	Clutch disc (Dirty or burned)	Clutch disc (Oily)	Clutch disc (Worn out)	Clutch disc (Hardened)	Clutch disc (Lack of spline grease)	Diaphragm spring (Damaged)	Diaphragm spring (Out of tip alignment)	Pressure plate (Distortion)	Flywheel (Distortion)
Symptom	Clutch grabs/chatters		1			2			2	2	2			2		
	Clutch noisy			1												
	Clutch slips	1							2	2			3		4	5
	Clutch does not disengage	1			2	2	2	2	2			2	3	3	4	

GI
 MA
 EM
 LC
 EC
 FE
CL
 MT
 AT
 FA
 RA
 BR
 ST
 RS
 BT
 HA
 EL
 IDX

CLUTCH SYSTEM

SEC. 300 • 307 • 465

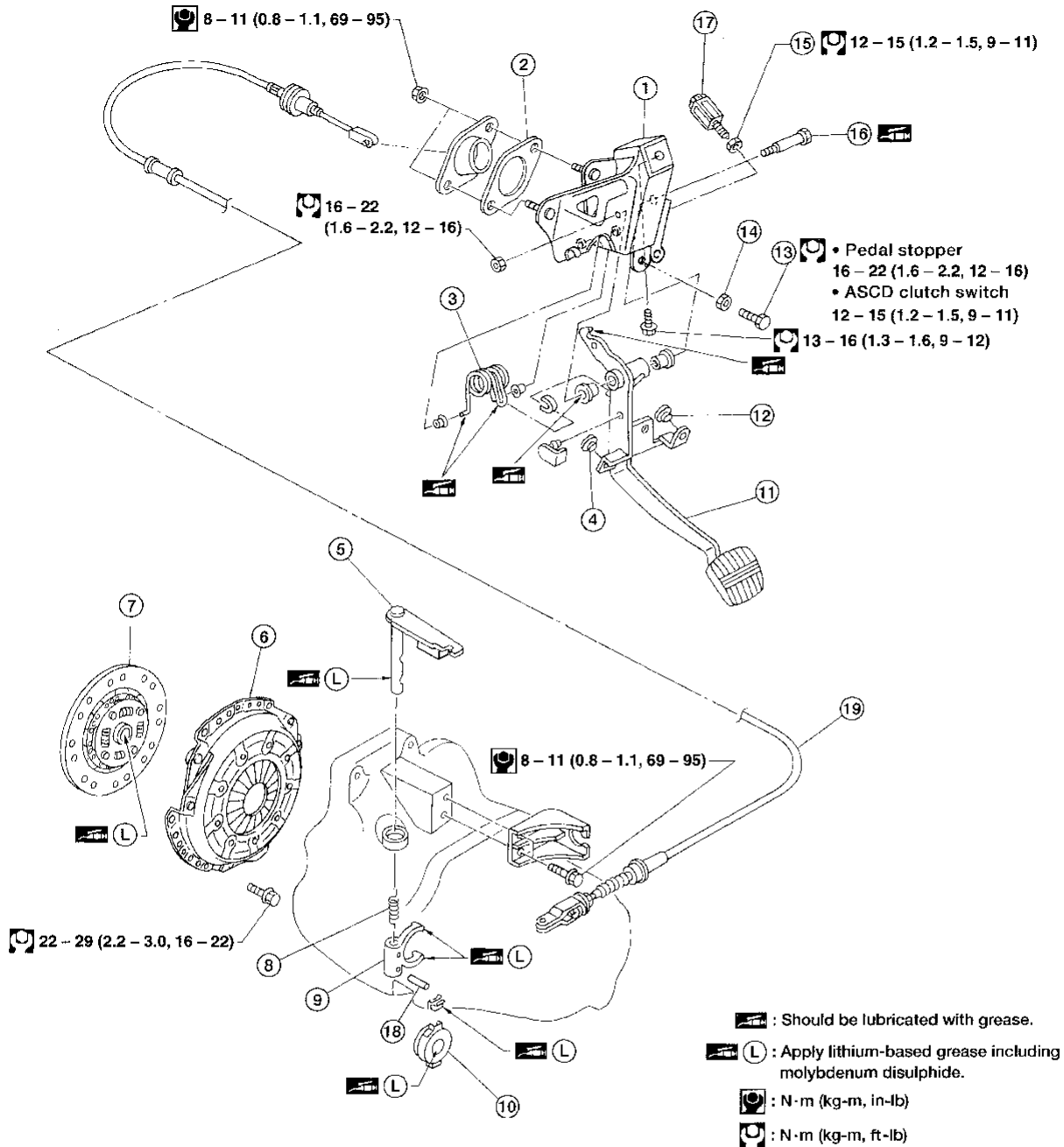

- ① Clutch pedal bracket
- ② Insulator
- ③ Assist spring
- ④ Stopper rubber
- ⑤ Withdrawal lever
- ⑥ Clutch cover
- ⑦ Clutch disc

- ⑧ Return spring
- ⑨ Clutch lever
- ⑩ Release bearing
- ⑪ Clutch pedal
- ⑫ Stopper rubber
- ⑬ Pedal stopper or ASCD clutch switch

- ⑭ Lock nut
- ⑮ Lock nut
- ⑯ Fulcrum pin
- ⑰ Clutch interlock switch
- ⑱ Spring pin
- ⑲ Clutch cable

ACL068

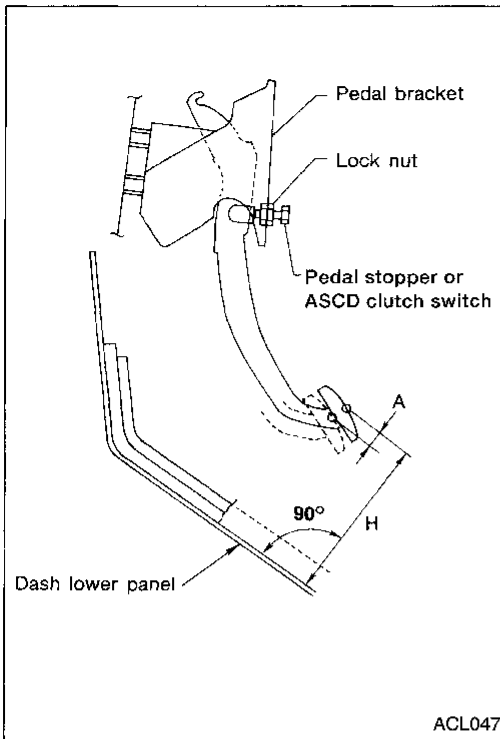

Adjusting Clutch Pedal

1. Adjust pedal height with pedal stopper or ASCD clutch switch.

Pedal height "H":
153 - 163 mm (6.02 - 6.42 in)

2. Adjust withdrawal lever play "B" according to the following procedure.

CAUTION:

When clutch cable is replaced with a new one, fully depress clutch pedal 50 times as a break-in procedure (to pre-stretch the clutch cable). Then, adjust the cable as follows.

- a. Push withdrawal lever by hand until resistance is felt, and then tighten adjusting nut.
- b. Turn back adjusting nut 2.5 to 3.5 turns, and then tighten lock nut.

Withdrawal lever play "B":
2.5 - 3.5 mm (0.098 - 0.138 in)

Lock nut:

Ⓜ: 4.3 - 5.9 N·m (0.44 - 0.60 kg·m, 38 - 52 in·lb)

3. As a final check, measure pedal free travel at center of pedal pad.

Pedal free travel "A":
11.0 - 15.0 mm (0.433 - 0.591 in)

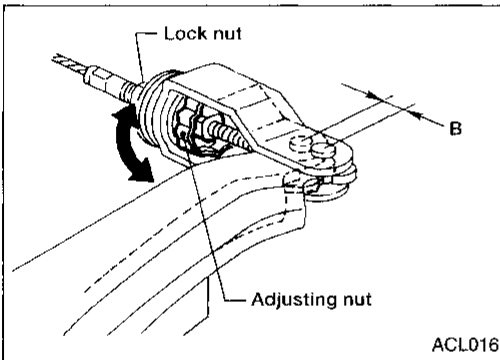

4. Adjust clearance "C" shown in the figure while fully depressing clutch pedal.

Clearance "C":
0.3 - 1.0 mm (0.012 - 0.039 in)

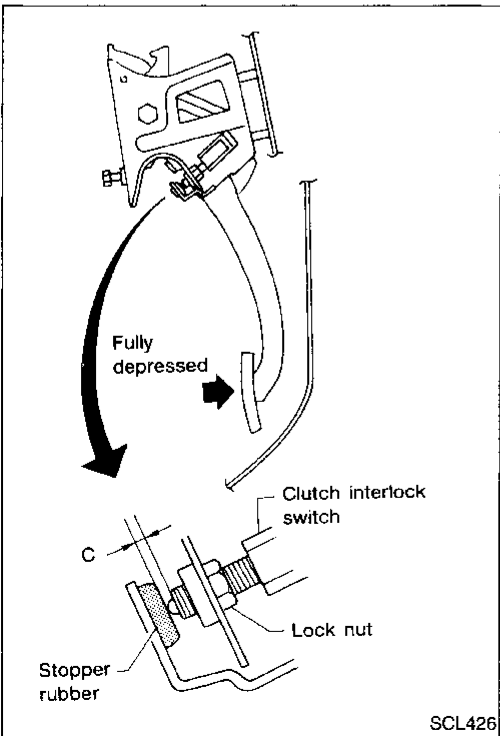

GI

MA

EM

LC

EC

FE

CL

MT

AT

FA

RA

BR

ST

RS

BT

HA

EL

IDX

CLUTCH RELEASE MECHANISM

SEC. 321

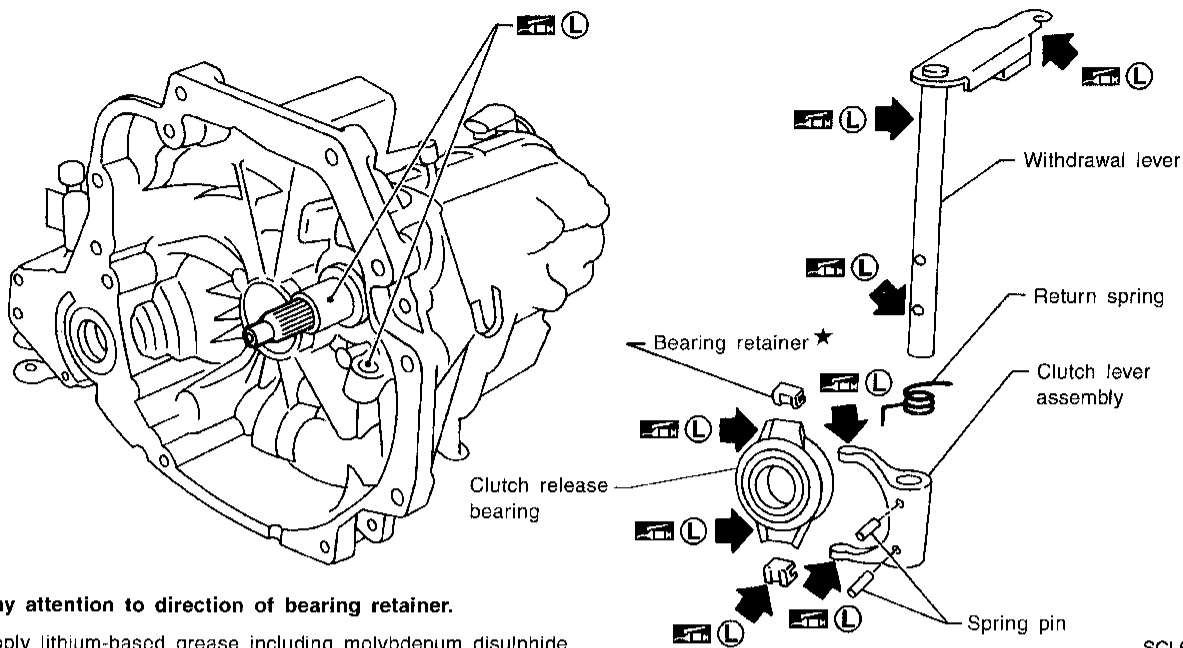

★ : Pay attention to direction of bearing retainer.

L : Apply lithium-based grease including molybdenum disulphide.

SCL666

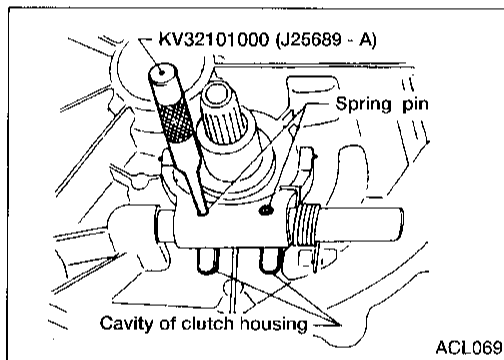

ACL069

Clutch Release Mechanism

REMOVAL AND INSTALLATION

- Remove release bearing by pulling bearing retainers outward.
- Align spring pin with cavity of clutch housing and tap out spring pin.
- To install, reverse removal procedure.

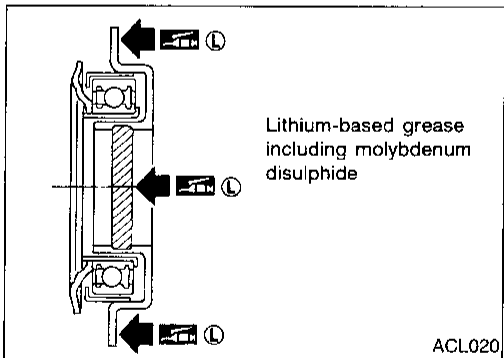

ACL020

INSPECTION

Check the following items, and replace if necessary.

- Release bearing, to see that it rolls freely and is free from noise, cracks, pitting or wear
- Release sleeve and withdrawal lever rubbing surface, for wear, rust or damage

LUBRICATION

- Apply recommended grease to contact surface and rubbing surface.
- **Too much lubricant may damage clutch disc facing.**

CLUTCH DISC AND CLUTCH COVER

SEC. 300

Flywheel

Clutch disc

Clutch cover

First step: 10 – 20 (1.0 – 2.0, 7.2 – 14)
Final step: 22 – 29 (2.2 – 3.0, 16 – 22)

- Do not clean in solvent.
- When installing, be careful that grease from main drive shaft does not adhere to clutch disc.

Apply lithium-based grease including molybdenum disulphide.

N·m (kg·m, ft·lb)

ACL070

GI
MA
EM
LC
EC
FE
CL
MT
AT
FA
RA
BR
ST
RS
BT
HA
EL
IDX

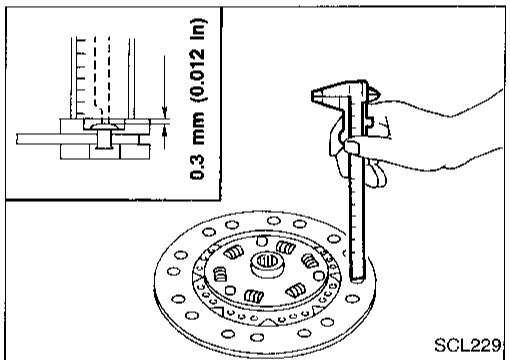

Clutch Disc

INSPECTION

Check the following items, and replace if necessary.

- Clutch disc, for burns, discoloration, oil or grease leakage
- Clutch disc, for wear of facing

Wear limit of facing surface to rivet head:
0.3 mm (0.012 in)

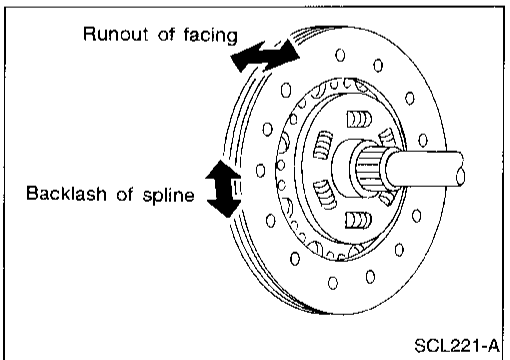

- Clutch disc, for backlash of spline and runout of facing
- Maximum backlash of spline (at outer edge of disc):**

0.8 mm (0.031 in)

Runout limit:

1.0 mm (0.039 in)

Distance of runout check point (from hub center):
90 mm (3.54 in)

INSTALLATION

- Apply recommended grease to contact surface of splines.
- Too much lubricant may damage clutch disc facing.**

CLUTCH DISC AND CLUTCH COVER

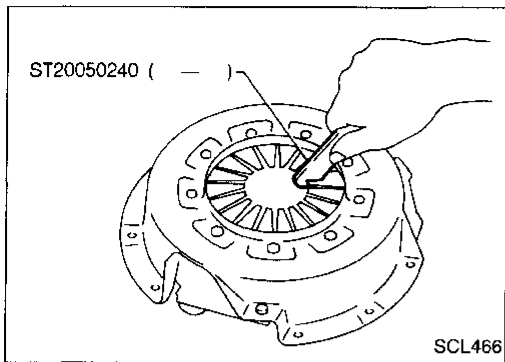

Clutch Cover and Flywheel

INSPECTION AND ADJUSTMENT

- Check clutch cover while installed on vehicle for uneven diaphragm spring toe height.
Uneven limit:
0.7 mm (0.028 in)
- If out of limit, adjust the height with Tool.

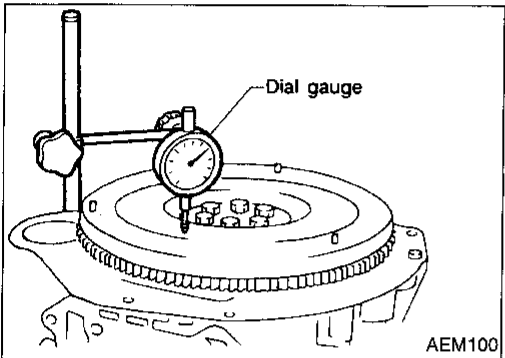

FLYWHEEL INSPECTION

CAUTION:

Do not allow any magnetic materials to contact the ring gear teeth.

- Inspect contact surface of flywheel for slight burns or discoloration. Clean flywheel with emery paper.
- Check flywheel runout.

Maximum allowable runout:

Refer to EM section ("Inspection", "CYLINDER BLOCK").

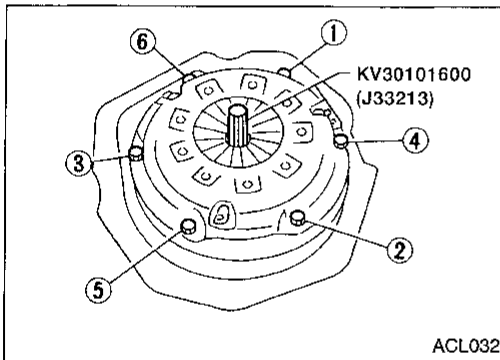

INSTALLATION

- Insert Tool into clutch disc hub when installing clutch cover and disc.
- Be careful not to allow grease to contaminate clutch facing.
- Tighten bolts in numerical order, in two steps.

First step:

: 10 - 20 N·m (1.0 - 2.0 kg-m, 7.0 - 14 ft-lb)

Final step:

: 22 - 29 N·m (2.2 - 3.0 kg-m, 16 - 22 ft-lb)

SERVICE DATA AND SPECIFICATIONS (SDS)

General Specifications

CLUTCH CONTROL SYSTEM

Type of clutch control	Mechanical type
------------------------	-----------------

CLUTCH DISC

Unit: mm (in)

Engine	GA16DE
Model	190
Facing size (Outer dia. x inner dia. x thickness)	190 x 132 x 3.5 (7.48 x 5.20 x 0.138)
Thickness of disc assembly with load	7.6 - 8.0 (0.315 - 0.331) with 3,825 N (390 kg, 860 lb)

CLUTCH COVER

Engine	GA16DE
Model	190
Full-load N (kg, lb)	3,825 (390, 860)

Inspection and Adjustment

CLUTCH PEDAL

Unit: mm (in)

Pedal height "H" ^{*1}	153 - 163 (6.02 - 6.42)
Pedal free travel "A" (at pedal pad)	11.0 - 15.0 (0.433 - 0.591)
Withdrawal lever play "B"	2.5 - 3.5 (0.098 - 0.138)
Clearance "C" (between pedal stopper rubber and clutch inter- lock switch) ^{*2}	0.3 - 1.0 (0.012 - 0.039)

*1: Measured from surface of dash lower panel to surface of pedal pad.

*2: Clutch pedal fully depressed.

CLUTCH DISC

Unit: mm (in)

Model	190
Wear limit of facing surface to rivet head	0.3 (0.012)
Runout limit of facing	1.0 (0.039)
Distance of runout check point (from hub center)	90 (3.54)
Maximum backlash of spline (at outer edge of disc)	0.8 (0.031)

CLUTCH COVER

Unit: mm (in)

Model	190
Diaphragm spring height	29.7 - 31.7 (1.169 - 1.248)
Uneven limit of diaphragm spring toe height	0.7 (0.028)

GI

MA

EM

LC

EC

FE

CL

MT

AT

FA

RA

BR

ST

RS

BT

HA

EL

IDX