

A  
B  
C

**SECTION AV**

**AUDIO, VISUAL & TELEPHONE SYSTEM**

**CONTENTS**

D  
E

<b>AUDIO</b> .....	<b>2</b>	<b>PREMIUM SYSTEM</b> .....	<b>9</b>	F
System Description .....	2	Inspection .....	9	
<b>BASE SYSTEM</b> .....	<b>2</b>	<b>AUDIO UNIT</b> .....	<b>9</b>	G
<b>MID LEVEL SYSTEM</b> .....	<b>2</b>	<b>ANTENNA</b> .....	<b>9</b>	
<b>PREMIUM SYSTEM</b> .....	<b>2</b>	Audio Unit/CD Changer (If Equipped) Removal and Installation .....	9	H
Wiring Diagram — AUDIO — /Base and Mid Level System .....	4	<b>LOCKING CD CHANGER UNIT MECHANISM</b> ...	10	I
Wiring Diagram — AUDIO — /Premium System .....	6	Subwoofer (With Premium Audio System) Removal and Installation .....	10	
Trouble Diagnoses .....	8	Location of Antenna .....	11	J
<b>AUDIO UNIT</b> .....	<b>8</b>	Antenna Removal and Installation .....	11	
<b>BASE AND MID LEVEL SYSTEM</b> .....	<b>8</b>			

## AUDIO

### System Description BASE SYSTEM

Refer to Owner's Manual for audio system operating instructions.

Power is supplied at all times:

- through 15A fuse (No. 32, located in the fuse and fusible link box)
- to audio unit terminal 6.

With the ignition switch in the ACC or ON position, power is supplied:

- through 10A fuse [No. 1, located in the fuse block (J/B)]
- to audio unit terminal 10.

Ground is supplied through the case of the audio unit.

Audio signals are supplied:

- through audio unit terminals 1, 2, 3, 4, 13, 14, 15 and 16
- to terminals + and - of front door speaker LH and RH
- to terminals + and - of rear speaker LH and RH.

### MID LEVEL SYSTEM

Refer to Owner's Manual for audio system operating instructions.

Power is supplied at all times:

- through 15A fuse (No. 32, located in the fuse and fusible link box)
- to audio unit terminal 6,
- to CD changer terminal 24 (with CD changer), and
- to subwoofer amp. terminal 8.

With the ignition switch in the ACC or ON position, power is supplied:

- through 10A fuse [No. 1, located in the fuse block (J/B)]
- to audio unit terminal 10, and
- to CD changer terminal 21 (with CD changer).

Ground is supplied through the case of the audio unit and CD changer (with CD changer).

Ground is supplied to subwoofer amp. terminal 7 through body grounds B13 and B19.

Audio signals are supplied:

- through audio unit terminals 1, 2, 3, 4, 13, 14, 15 and 16
- to terminals + and - of front door speaker LH and RH
- to terminals + and - of rear speaker LH and RH
- to terminals + and - of pillar tweeter LH and RH and
- to terminals 1, 2, 3 and 4 of subwoofer amp.

### PREMIUM SYSTEM

Refer to Owner's Manual for audio system operating instructions.

Power is supplied at all times:

- through 15A fuse (No. 32, located in the fuse and fusible link box)
- to audio unit terminal 6 and
- to CD changer terminal 24 (with CD changer), and
- through 20A fuse (No. 42, located in the fuse and fusible link box)
- to audio amplifier terminals 5 and 12.

With the ignition switch in the ACC or ON position, power is supplied:

- through 10A fuse [No. 1, located in the fuse block (J/B)]
- to audio unit terminal 10 and
- to CD changer terminal 21 (with CD changer).

Ground is supplied through the case of the audio unit and CD changer (with CD changer).

Ground is supplied

- to audio amplifier terminals 4 and 11

# AUDIO

---

- through body grounds B13 and B19.

Audio signals are supplied:

- through audio unit terminals 1, 2, 3, 4, 13, 14, 15 and 16
- to audio amplifier terminals 15, 16, 17, 20, 21, 22, 23 and 24.

The audio signals are amplified by the audio amplifier and then supplied:

- through audio amplifier terminals 1, 2, 3, 6, 7, 8, 9 and 10.
- to terminals + and - of front door speaker LH and RH
- to terminals + and - of rear speaker LH and RH
- to terminals + and - of pillar tweeter LH and RH and
- to terminals 1, 2, 3 and 4 of subwoofer.

A

B

C

D

E

F

G

H

I

J

AV

L

M

# AUDIO

## Wiring Diagram — AUDIO — /Base and Mid Level System

EKS003AJ

AV-AUDIO-01

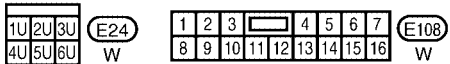
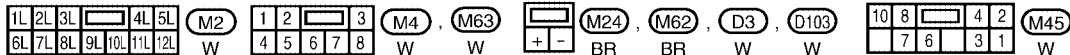
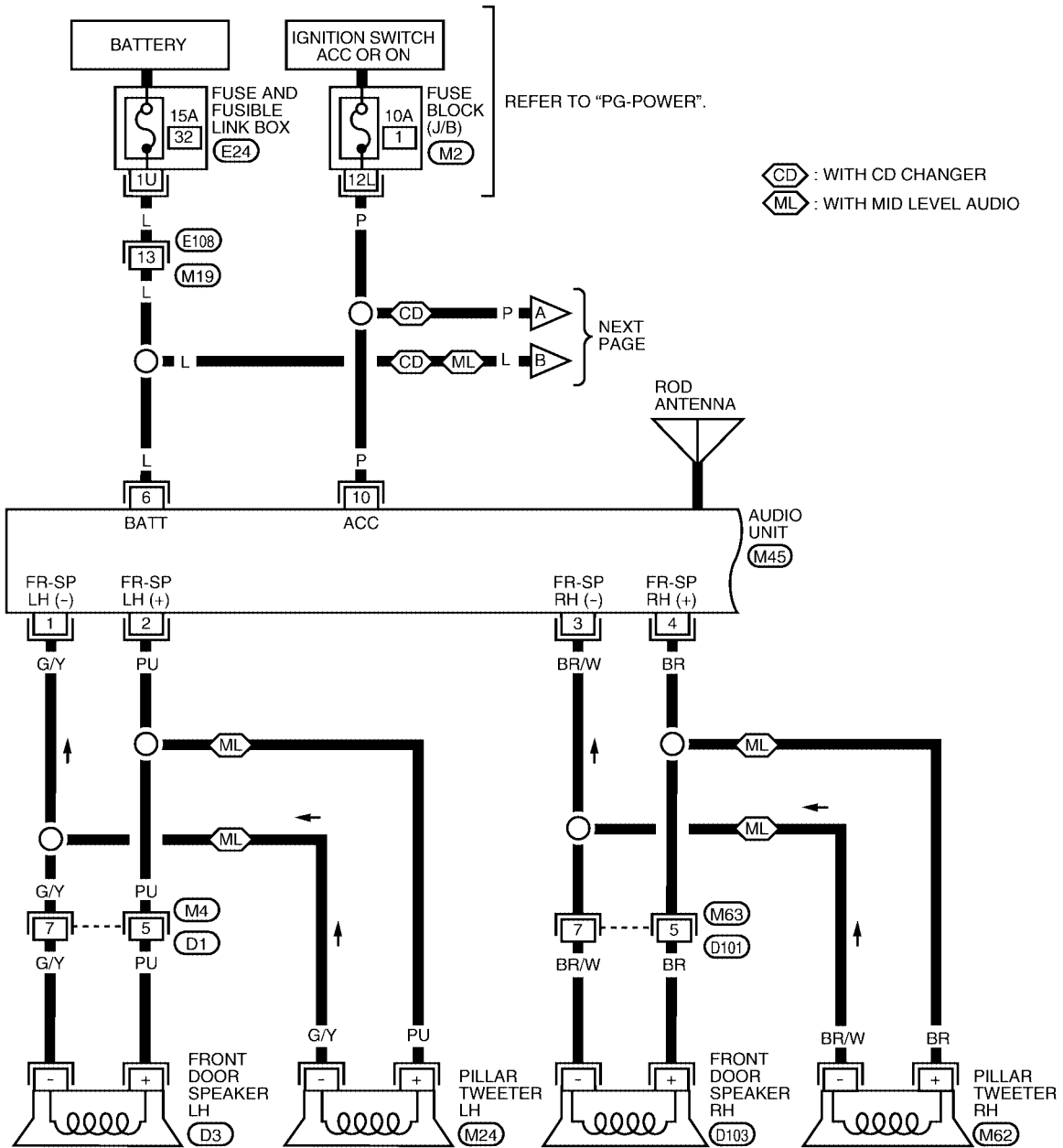

LKWA0129E

# AUDIO

AV-AUDIO-02

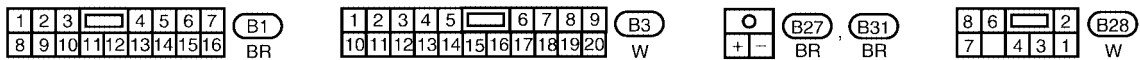
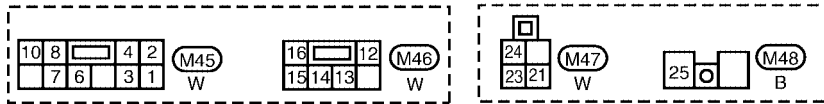
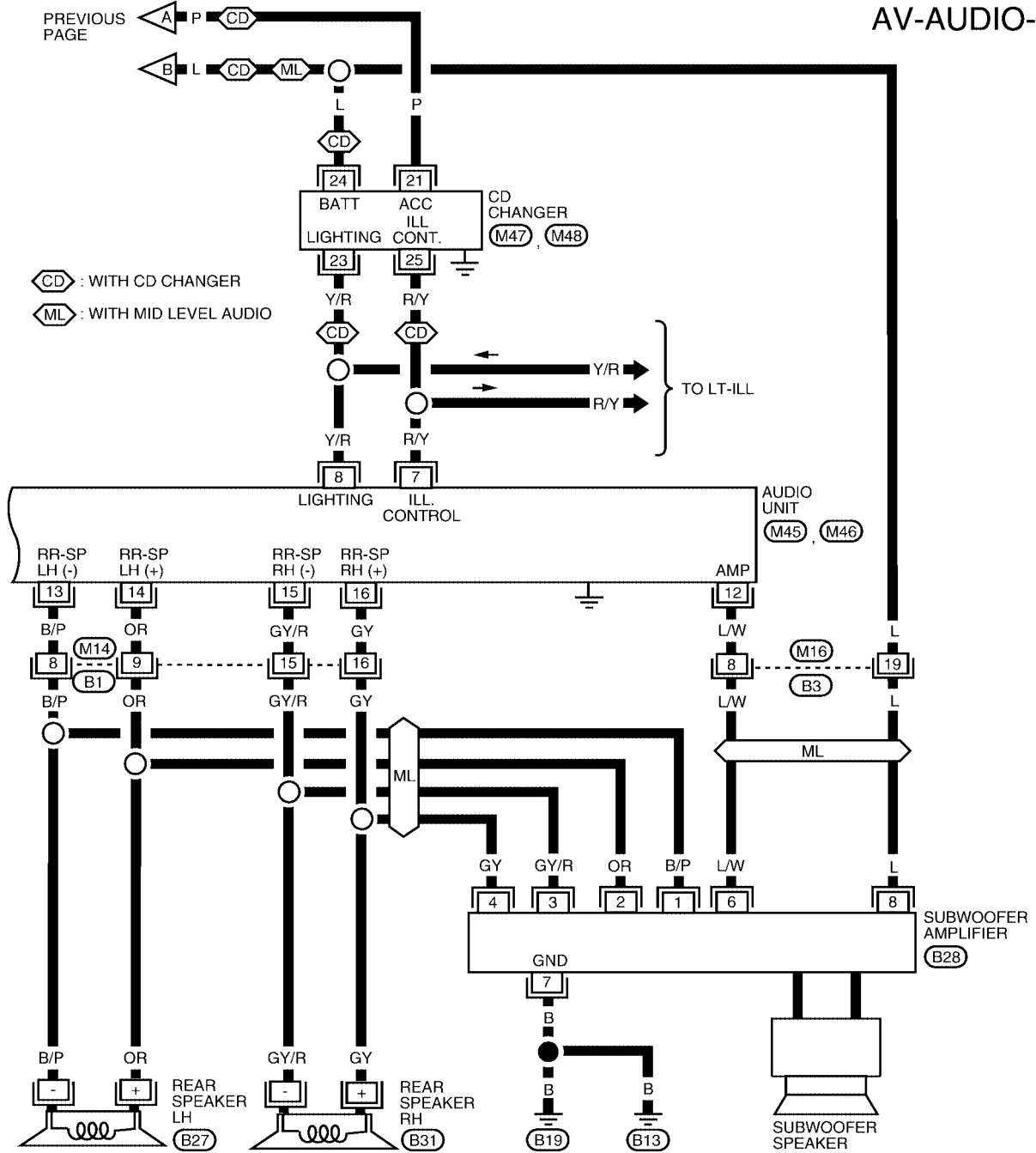

WKWA0153E

# AUDIO

## Wiring Diagram — AUDIO — /Premium System

EKS003AK

AV-AUDIO-03

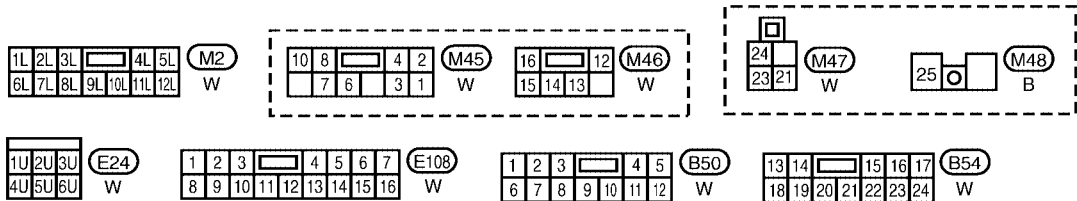
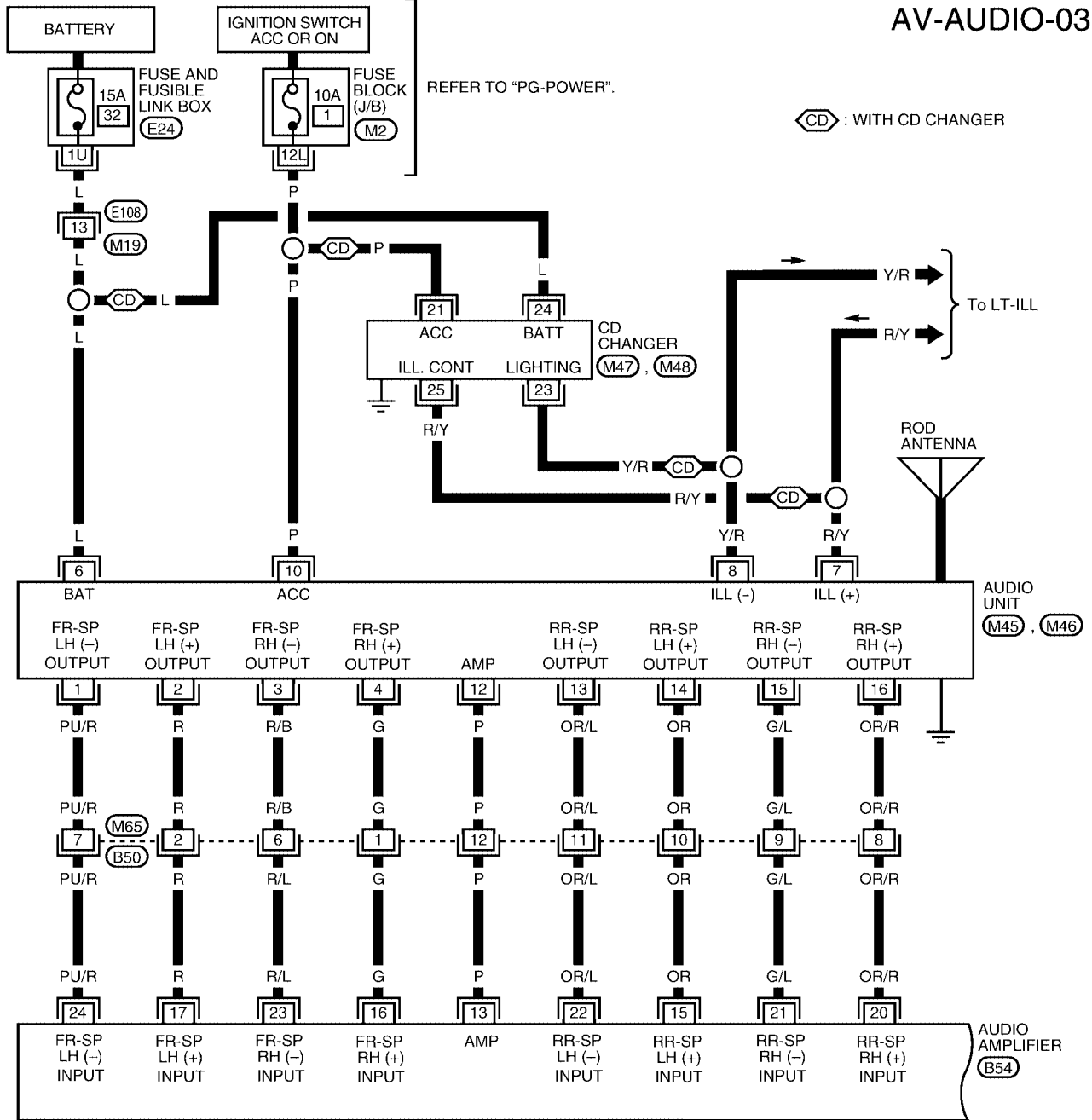

LKW0130E

# AUDIO

AV-AUDIO-04

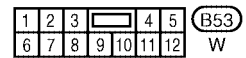
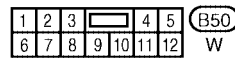
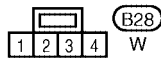
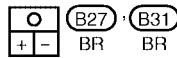
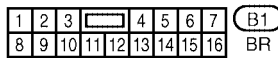
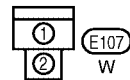
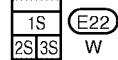
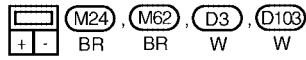
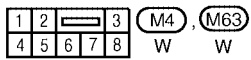
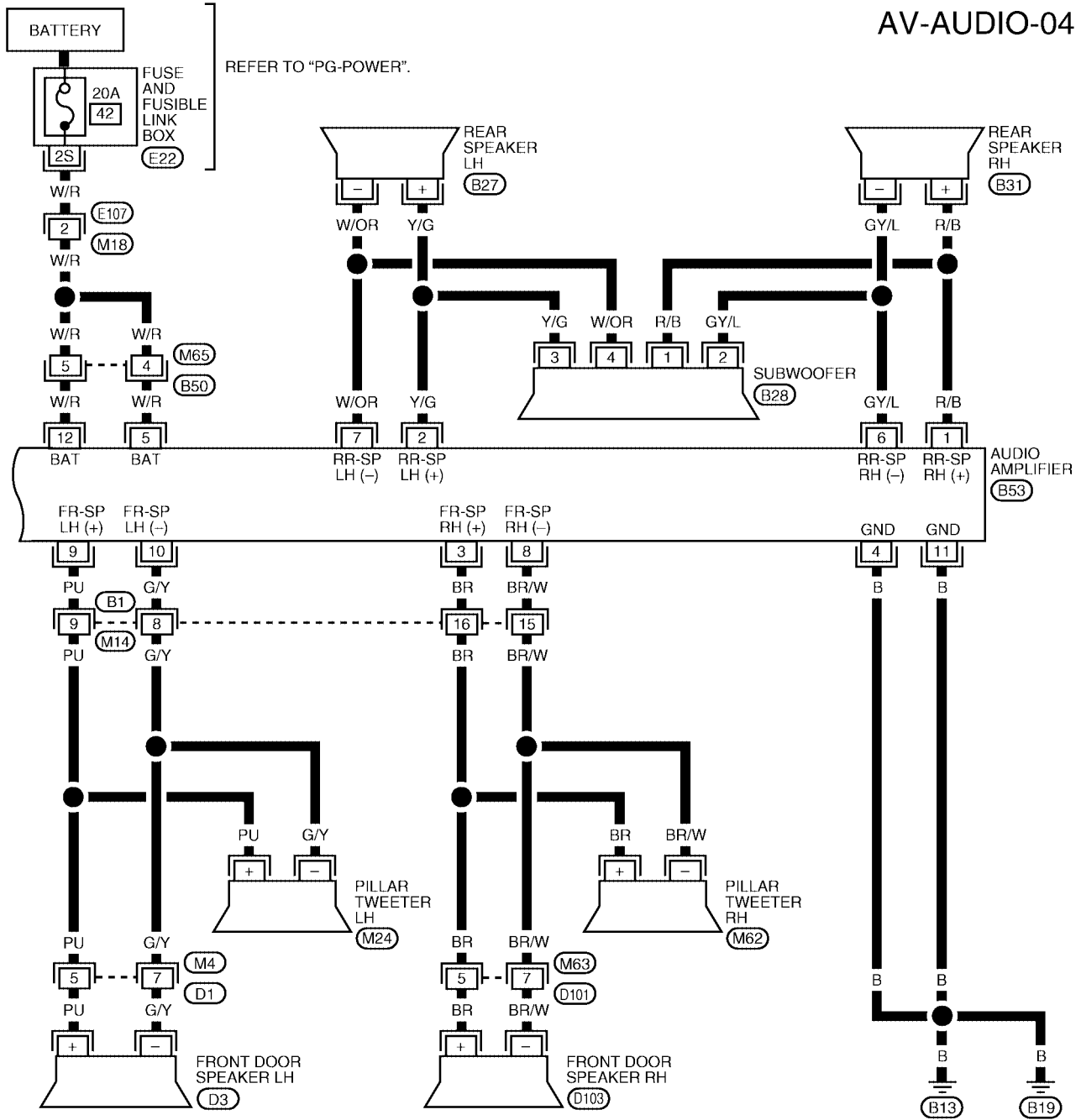

WKWA0499E

# AUDIO

EKS003AL

## Trouble Diagnoses AUDIO UNIT

Symptom	Possible causes	Repair order
Audio unit inoperative (no digital display and no sound from speakers).	<ol style="list-style-type: none"> <li>10A fuse</li> <li>Poor audio unit case ground</li> <li>Audio unit</li> </ol>	<ol style="list-style-type: none"> <li>Check 10A fuse [No. 1, located in fuse block (J/B)]. Turn ignition switch ON and verify that battery positive voltage is present at terminal 10 of audio unit.</li> <li>Check audio unit case ground.</li> <li>Remove audio unit for repair.</li> </ol>
Audio unit presets are lost when ignition switch is turned OFF.	<ol style="list-style-type: none"> <li>15A fuse</li> <li>Audio unit</li> </ol>	<ol style="list-style-type: none"> <li>Check 15A fuse [No. 32, located in fuse and fusible link box] and verify that battery positive voltage is present at terminal 6 of audio unit.</li> <li>Remove audio unit for repair.</li> </ol>
AM/FM stations are weak or noisy.	<ol style="list-style-type: none"> <li>Antenna</li> <li>Poor audio unit case ground</li> <li>Audio unit</li> </ol>	<ol style="list-style-type: none"> <li>Check antenna.</li> <li>Check audio unit case ground.</li> <li>Remove audio unit for repair.</li> </ol>
Audio unit generates noise in AM and FM modes with engine running.	<ol style="list-style-type: none"> <li>Poor audio unit case ground</li> <li>Loose or missing ground bonding straps</li> <li>Ignition condenser or rear window defogger noise suppressor condenser</li> <li>Ignition coil(s)</li> <li>Audio unit</li> </ol>	<ol style="list-style-type: none"> <li>Check audio unit case ground.</li> <li>Check ground bonding straps.</li> <li>Replace ignition condenser or rear window defogger noise suppressor condenser.</li> <li>Check ignition coil(s).</li> <li>Remove audio unit for repair.</li> </ol>
Audio unit generates noise in AM and FM modes with accessories on (switch pops and motor noise).	<ol style="list-style-type: none"> <li>Poor audio unit case ground</li> <li>Antenna</li> <li>Accessory ground</li> <li>Faulty accessory</li> </ol>	<ol style="list-style-type: none"> <li>Check audio unit case ground.</li> <li>Check antenna.</li> <li>Check accessory ground.</li> <li>Replace accessory.</li> </ol>

## BASE AND MID LEVEL SYSTEM

Symptom	Possible causes	Repair order
Individual speaker is noisy or inoperative.	<ol style="list-style-type: none"> <li>Speaker</li> <li>Audio unit output</li> <li>Speaker circuit</li> <li>Audio unit</li> </ol>	<ol style="list-style-type: none"> <li>Check speaker.</li> <li>Check audio unit output voltages.</li> <li>Check circuits for open or short between the audio unit and the speaker.</li> <li>Remove audio unit for repair.</li> </ol>
Audio unit controls are operational, but no sound is heard from any speaker.	<ol style="list-style-type: none"> <li>Speaker</li> <li>Speaker circuit</li> <li>Audio unit</li> </ol>	<ol style="list-style-type: none"> <li>Check speaker.</li> <li>Check circuits for open or short between the audio unit and the speaker.</li> <li>Remove audio unit for repair.</li> </ol>



# AUDIO

## PREMIUM SYSTEM

Symptom	Possible causes	Repair order
Audio unit controls are operational, but no sound is heard from any speaker.	<ol style="list-style-type: none"> <li>20A fuse</li> <li>Amp. ON/OFF signal circuit</li> <li>Audio amplifier ground</li> <li>Audio unit</li> <li>Audio amplifier</li> </ol>	<ol style="list-style-type: none"> <li>Check 20A fuse (No. 42, located in fuse and fusible link box). Verify that battery positive voltage is present at audio amplifier terminals 5 and 12.</li> <li>Check harness continuity between audio unit terminal 12 and audio amplifier terminal 13.</li> <li>Check harness continuity between audio amplifier terminals 4 and 11 and ground.</li> <li>Remove audio unit for repair.</li> <li>Remove audio amplifier for repair.</li> </ol>
Individual speaker is noisy or inoperative.	<ol style="list-style-type: none"> <li>Speaker</li> <li>Output circuit to individual speaker</li> <li>Audio unit</li> <li>Audio amplifier</li> </ol>	<ol style="list-style-type: none"> <li>Check speaker.</li> <li>Check the output circuits to individual speaker                             <ul style="list-style-type: none"> <li>between audio unit and audio amplifier.</li> <li>between audio amplifier and speaker.</li> </ul> </li> <li>Remove audio unit for repair.</li> <li>Remove audio amplifier for repair.</li> </ol>
Subwoofer does not operate.	<ol style="list-style-type: none"> <li>Output circuit to subwoofer</li> <li>Subwoofer</li> <li>Audio amplifier</li> </ol>	<ol style="list-style-type: none"> <li>Check circuits for open or short between the audio amplifier and the subwoofer.</li> <li>Check subwoofer.</li> <li>Remove audio amplifier for repair.</li> </ol>

## Inspection AUDIO UNIT

EKS003AM

All voltage inspections are made with:

- Ignition switch ON or ACC
- Audio unit ON
- Audio unit connected (If audio unit is removed for inspection, supply a ground to the case using a jumper wire.)

## ANTENNA

Using a jumper wire, clip an auxiliary ground between antenna and body.

- If reception improves, check antenna ground (at body surface).
- If reception does not improve, check main feeder cable for short circuit or open circuit.

## Audio Unit/CD Changer (If Equipped) Removal and Installation

EKS003AN

### CAUTION:

Prior to removing a malfunctioning CD changer unit that will be shipped for repair, the changer mechanism **MUST BE LOCKED** to prevent the mechanism from being damaged during shipping. Refer to [AV-10, "LOCKING CD CHANGER UNIT MECHANISM"](#).

1. Remove upper cluster lid C by firmly grasping and carefully pulling rearward from instrument panel.
2. Remove lower cluster lid C by firmly grasping and carefully pulling rearward from instrument panel. Refer to [IP-10, "Removal and Installation"](#).
3. Remove six screws and remove audio unit and storage bin or CD changer (if equipped) as an assembly.

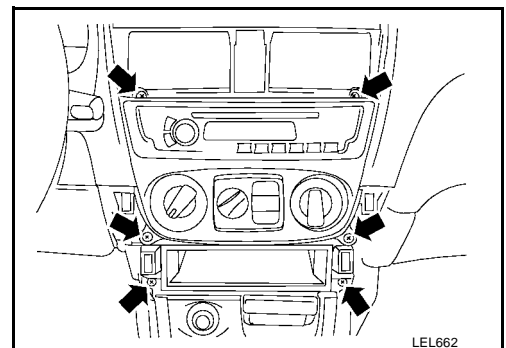

## AUDIO

4. Disconnect audio unit connectors and CD changer connectors (if equipped).

### CAUTION:

**Do not pry or forcibly remove heater A/C control bezel from audio unit face plate or audio unit damage could result.**

5. Release two tabs using a screwdriver and carefully remove heater A/C control bezel from audio unit face plate.
6. Remove brackets from audio unit and CD changer (if equipped).
7. Install in reverse order of removal.

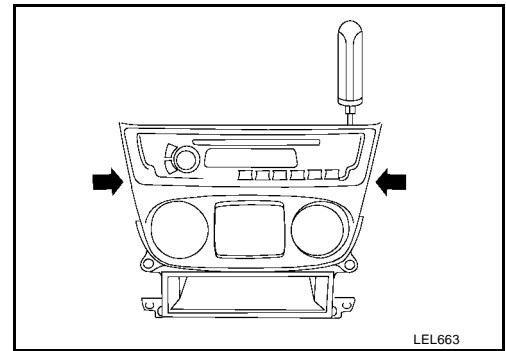

## LOCKING CD CHANGER UNIT MECHANISM

### CAUTION:

- Prior to removing a malfunctioning CD changer unit that will be shipped for repair, the changer mechanism **MUST BE LOCKED** to prevent the mechanism from being damaged during shipping.
  - If a CD is jammed or unable to be removed from the unit, do **NOT** lock the changer mechanism. If the unit is to be shipped for repair, carefully package the unit to prevent vibration and shock.
1. Eject and remove any CDs from the CD changer unit.
  2. Turn ignition switch OFF. Wait until CD changer unit display is off and mechanism stops moving (mechanism sound stops).
  3. Press any one of the disc selection buttons once. When a display shows on the CD changer unit, press the same disc selection button again within 5 seconds.
    - The changer mechanism will lock itself within 10 seconds.
  4. After mechanism stops moving (mechanism sound stops), disconnect the CD changer unit connectors.
  5. Remove the CD changer unit.

### NOTE:

After installing a new or remanufactured CD changer unit, switching the CD changer unit ON will automatically unlock the mechanism. A special unlocking procedure is not required.

## Subwoofer (With Premium Audio System) Removal and Installation

EKS003KW

1. Partially remove RH trunk room trim. Refer to [EI-33, "Removal and Installation"](#).
2. Pull cable to release RH rear seat back.
3. Remove rear seat bottom. Refer to [SE-5, "Removal and Installation"](#).

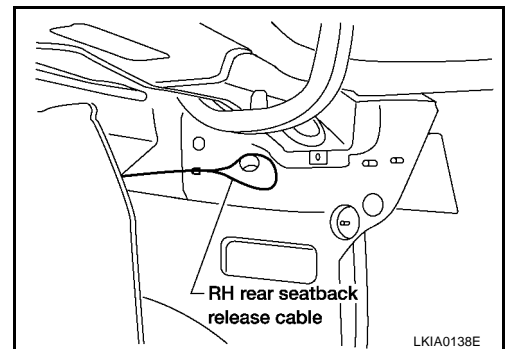

4. Fold RH rear seatback forward.

### NOTE:

When using the fold down rear seatback, the rear center seat belt retractor may lock up and prevent folding down the seatback.

If the rear center seat belt retractor has inadvertently locked up, push the seat belt webbing toward the retractor as shown. This will unlock the seat belt retractor and allow the rear seatback to fold down.

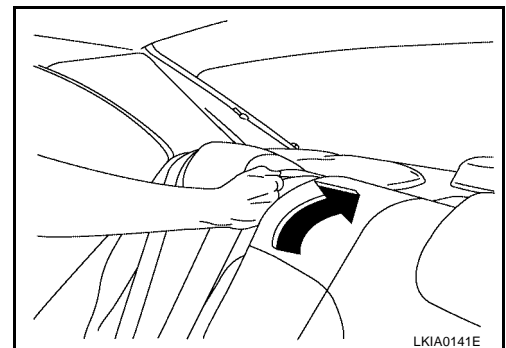

# AUDIO

5. Remove 2 upper subwoofer bolts.
6. Disconnect subwoofer connector.

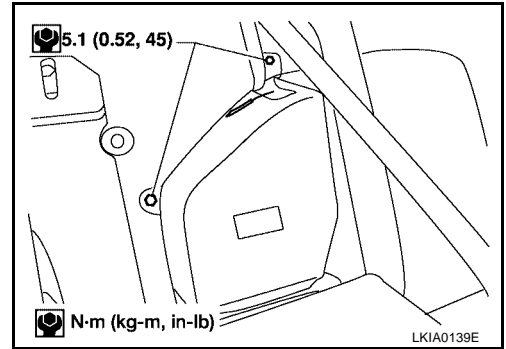

7. Remove 2 bolts from rear seatback center hinge. Refer to [SE-5, "Removal and Installation"](#).
8. Remove subwoofer through trunk.
9. Install in reverse order of removal.

## Location of Antenna

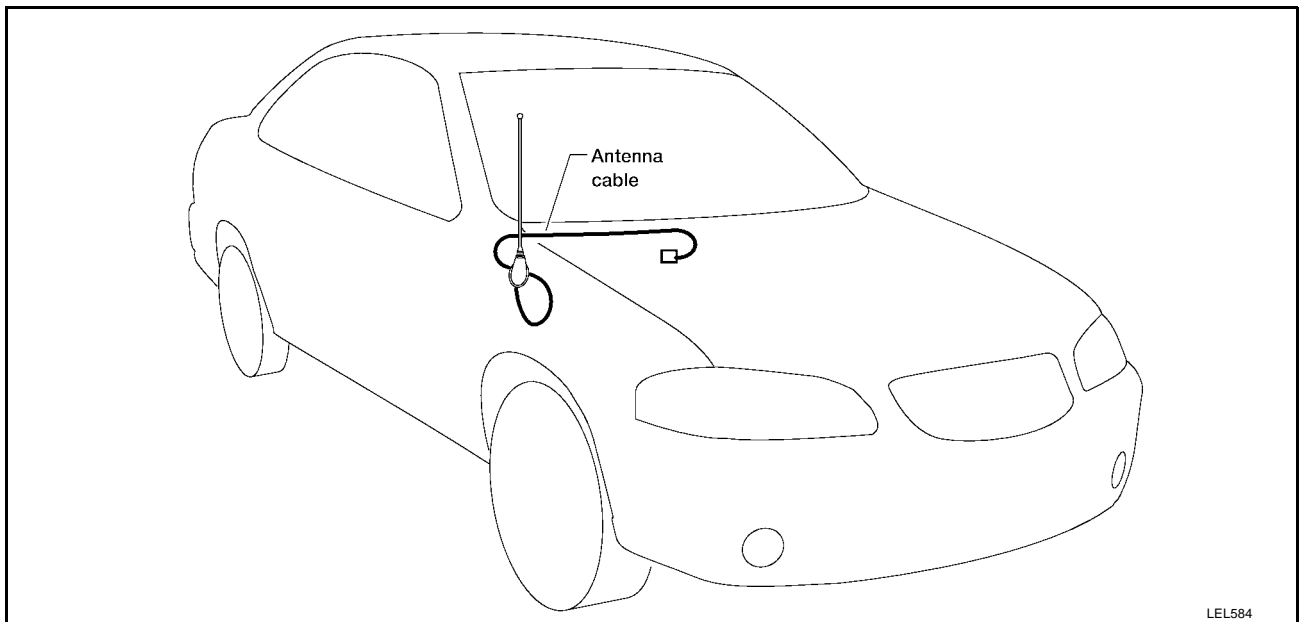

## Antenna Removal and Installation

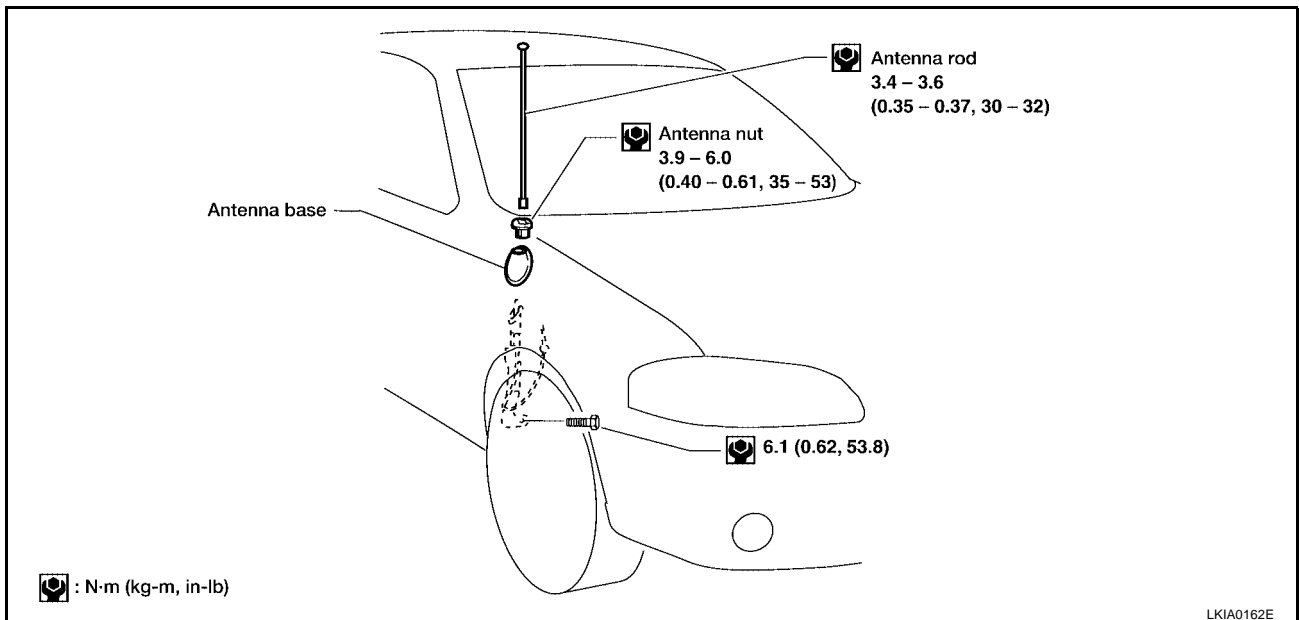

A  
B  
C  
D  
E  
F  
G  
H  
I  
J  
AV  
L  
M

# AUDIO

---