

SECTION **CL**
CLUTCH

A
B
CL

CONTENTS

QG18DE			
PRECAUTIONS	3		
Precautions	3		
PREPARATION	4		
Special Service Tools	4		
Commercial Service Tools	4		
NOISE, VIBRATION, AND HARSHNESS (NVH)			
TROUBLESHOOTING	5		
NVH Troubleshooting Chart	5		
CLUTCH SYSTEM	6		
Components	6		
Inspection and Adjustment	7		
CLUTCH PEDAL INSPECTION AND ADJUST- MENT	7		
BLEEDING PROCEDURE	7		
CLUTCH MASTER CYLINDER	9		
Components	9		
Removal	9		
Disassembly	9		
Inspection	10		
Assembly	10		
Installation	10		
OPERATING CYLINDER	11		
Components	11		
Removal	11		
Disassembly	11		
Inspection	11		
Assembly	12		
Installation	12		
PIPING	13		
Removal	13		
Installation	13		
CLUTCH RELEASE MECHANISM	14		
Components	14		
Removal	14		
Inspection	14		
Installation	14		
CLUTCH DISC, CLUTCH COVER AND FLYWHEEL	17		
Components	17		
Inspection and Adjustment	17		
		CLUTCH DISC	17
		CLUTCH COVER AND FLYWHEEL	18
		FLYWHEEL INSPECTION	18
		Installation	18
		SERVICE DATA AND SPECIFICATIONS (SDS)	19
		Clutch Control System	19
		Clutch Master Cylinder	19
		Clutch Operating Cylinder	19
		Clutch Disc	19
		Clutch Cover	19
		Clutch Pedal	19
		QR25DE	
		PRECAUTIONS	20
		Precautions	20
		PREPARATION	21
		Special Service Tools	21
		Commercial Service Tools	21
		NOISE, VIBRATION, AND HARSHNESS (NVH)	
		TROUBLESHOOTING	22
		NVH Troubleshooting Chart	22
		CLUTCH SYSTEM	23
		Components	23
		Inspection and Adjustment	24
		CLUTCH PEDAL INSPECTION AND ADJUST- MENT	24
		BLEEDING PROCEDURE	24
		CLUTCH MASTER CYLINDER	26
		Components	26
		Removal	26
		Disassembly	26
		Inspection	26
		Assembly	27
		Installation	27
		OPERATING CYLINDER	28
		Components	28
		Removal	28
		Disassembly	28
		Inspection	28

D
E
F
G
H
I
J
K
L
M

Assembly	29	Inspection and Adjustment	33
Installation	29	CLUTCH DISC	33
PIPING	30	CLUTCH COVER AND FLYWHEEL	34
Removal	30	FLYWHEEL INSPECTION	34
Installation	30	Installation	34
CLUTCH RELEASE MECHANISM	31	SERVICE DATA AND SPECIFICATIONS (SDS)	35
Components	31	Clutch Control System	35
Removal	31	Clutch Master Cylinder	35
Inspection After Removal	31	Clutch Operating Cylinder	35
Installation	31	Clutch Disc	35
CLUTCH DISC, CLUTCH COVER AND FLYWHEEL..	33	Clutch Cover	35
Components	33	Clutch Pedal	35

PRECAUTIONS

PF0:00001

Precautions

ECS005RJ

- The recommended clutch system hydraulic fluid is brake fluid “DOT 3”.
- Do not reuse drained brake fluid.
- Be careful not to splash brake fluid on painted areas; it may cause paint damage. If any brake fluid is splashed on painted areas, wash it away with water immediately.
- Use a flare nut wrench (commercial service tool) when removing or installing the clutch hydraulic tubes.

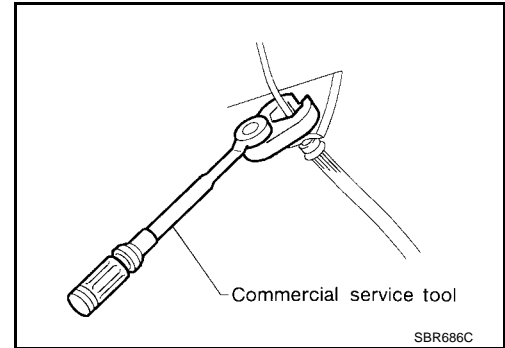

- Use new brake fluid to clean or wash any parts of the clutch master cylinder and operating cylinder.
- Never use any type of mineral oil such as gasoline or kerosene to clean or wash any parts of the clutch system. It will ruin the rubber parts of the hydraulic system.

WARNING:

After cleaning the clutch disc, wipe it with a dust collector. Do not use compressed air.

A
B
CL
D
E
F
G
H
I
J
K
L
M

PREPARATION

[QG18DE]

PFP:00002

PREPARATION

Special Service Tools

ECS005RK

The actual shapes of Kent-Moore tools may differ from those of special service tools illustrated here.

Tool number (Kent-Moore No.) Tool name		Description
KV30101600 (New) KV30101000 (Former) (J33213) Clutch aligning bar		Installing clutch cover and clutch disc a: 15.9 mm (0.626 in) dia. b: 17.9 mm (0.705 in) dia. c: 40 mm (1.57 in)
ST20050240 (—) Diaphragm spring adjusting wrench		Adjusting unevenness of diaphragm spring of clutch cover a: 150 mm (5.91 in) b: 25 mm (0.98 in)
KV32101000 (J25689-A) Pin punch		Removing and installing spring pin a: 4 mm (0.16 in) dia.

Commercial Service Tools

ECS005RL

Tool name		Description
1: Flare nut crowfoot 2: Torque wrench		Removing and installing clutch piping a: 10 mm (0.39 in)

NOISE, VIBRATION, AND HARSHNESS (NVH) TROUBLESHOOTING

[QG18DE]

NOISE, VIBRATION, AND HARSHNESS (NVH) TROUBLESHOOTING

PF0:0003

NVH Troubleshooting Chart

ECS005RM

Use the chart below to help you find the cause of the symptom. The numbers indicate the order of inspection. Check each part in order. If necessary, repair or replace these parts.

Symptom		Suspected parts (possible cause)													Reference page					
		Clutch pedal (inspection and adjustment)	Clutch line (air in line)	Master cylinder piston cup (damaged)	Operating cylinder piston cup (damaged)	Engine mounting (loose)	Release bearing (worn, dirty or damaged)	Clutch disc (out of true)	Clutch disc (runout is excessive)	Clutch disc (lining broken)	Clutch disc (dirty or burned)	Clutch disc (oily)	Clutch disc (worn out)	Clutch disc (hardened)		Clutch disc (lack of spline grease)	Diaphragm spring (damaged)	Diaphragm spring (out of tip alignment)	Clutch cover (distortion)	Flywheel (distortion)
Symptom	Clutch grabs/chatters					1														
	Clutch pedal spongy		1	2	2															
	Clutch noisy						1													
	Clutch slips	1										2	2			3		4	5	
	Clutch does not disengage	1	2	3	4			5	5	5	5	5			5	6	6	7		

A
B
C
D
E
F
G
H
I
J
K
L
M

CL

CLUTCH SYSTEM

[QG18DE]

PF3:30502

ECS005RN

CLUTCH SYSTEM

Components

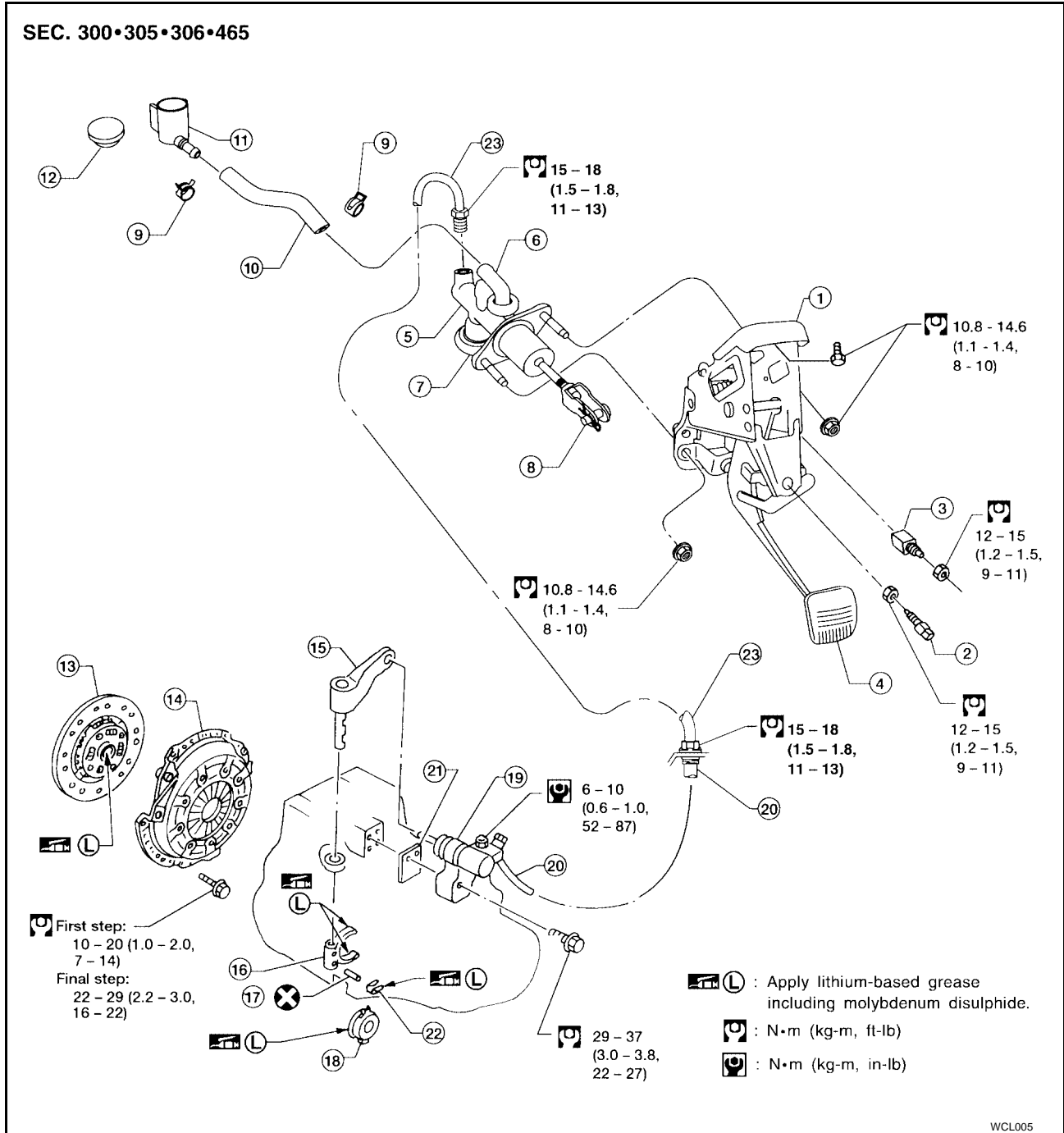

WCL005

- | | | |
|------------------------------------|-------------------------------------|----------------------------|
| 1. Clutch pedal bracket | 2. ASCD clutch switch (if equipped) | 3. Clutch interlock switch |
| 4. Clutch pedal | 5. Clutch master cylinder | 6. Nipple |
| 7. Clutch damper (not serviceable) | 8. Clevis | 9. Hose clamp |
| 10. Reservoir hose | 11. Reservoir tank | 12. Reservoir cap |
| 13. Clutch disc | 14. Clutch cover | 15. Withdrawal lever |
| 16. Clutch lever | 17. Spring pin | 18. Release bearing |
| 19. Operating cylinder | 20. Clutch hose | 21. Spacer |
| 22. Release bearing spring | 23. Clutch tube | |

Inspection and Adjustment

CLUTCH PEDAL INSPECTION AND ADJUSTMENT

1. Check to see if the clutch pedal clevis pin floats freely in the bore of the clutch pedal. It should not be bound by the clevis or clutch pedal.
 - a. If the pin is not free, check that the ASCD switch or pedal stopper bolt is not applying pressure to the clutch pedal causing the pin to bind. To adjust, loosen the ASCD switch or pedal stopper bolt lock nut and turn the ASCD switch or pedal stopper bolt.
 - b. Tighten the lock nut.
 - c. Verify that the clutch pedal clevis pin floats freely in the bore of the clutch pedal. It should not be bound by the clevis or clutch pedal.
 - d. If the pin is still not free, remove the pin and check for deformation or damage. Replace the pin if necessary. Leave the pin removed for step 2.
2. Check the clutch pedal stroke for free range of movement.
 - a. With the clutch pedal clevis pin removed, manually move the pedal up and down to determine if it moves freely.
 - b. If any sticking is noted, replace the related parts (clutch pedal, pedal bracket, assist spring, bushing, etc.). Reassemble the pedal and re-verify that the clevis pin floats freely in the bore of the pedal.
3. Adjust the clearance "C" while fully depressing the clutch pedal (with the clutch interlock switch) as shown.

Clearance "C" : 0.1 - 1.0 mm (0.004 - 0.039 in)

4. Check the clutch hydraulic system components (clutch master cylinder, clutch operating cylinder, Clutch withdrawal lever, clutch release bearing, etc.) for sticking or binding.
 - a. If any sticking or binding is noted, repair or replace the related parts as necessary.
 - b. If the hydraulic system was necessary, bleed the clutch hydraulic system. Refer to [CL-7, "BLEEDING PROCEDURE"](#).

NOTE:

Do not use a vacuum assist or any other type of power bleeder on this system. Use of a vacuum assist or power bleeder will not purge all of the air from the system.

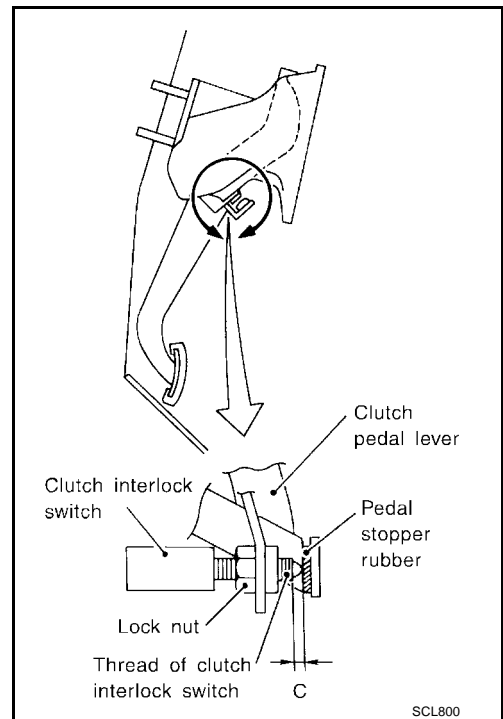
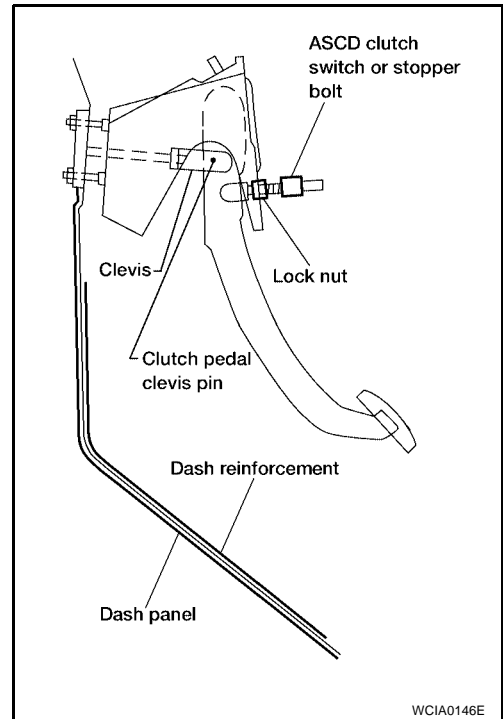

BLEEDING PROCEDURE

CAUTION:

Carefully monitor the fluid level at the clutch master cylinder during the bleeding operation.

NOTE:

Do not use a vacuum assist or any other type of power bleeder on this system. Use of a vacuum assist or power bleeder will not purge all of the air from the system.

A
B
CL
D
E
F
G
H
I
J
K
L
M

CLUTCH SYSTEM

[QG18DE]

1. Top off the clutch master cylinder reservoir with the recommended brake fluid "DOT 3". Then attach the additional supply tank as shown.

CAUTION:

Do not to splash brake fluid on painted areas; it may cause paint damage. If brake fluid is splashed on painted areas, wash it away with water immediately.

2. Connect a transparent vinyl tube to the air bleeder valve as shown.
3. Slowly depress the clutch pedal to its full stroke and release it completely. Repeat this operation several times at 2 to 3 seconds intervals.
4. Open the air bleeder valve with the clutch pedal fully depressed.

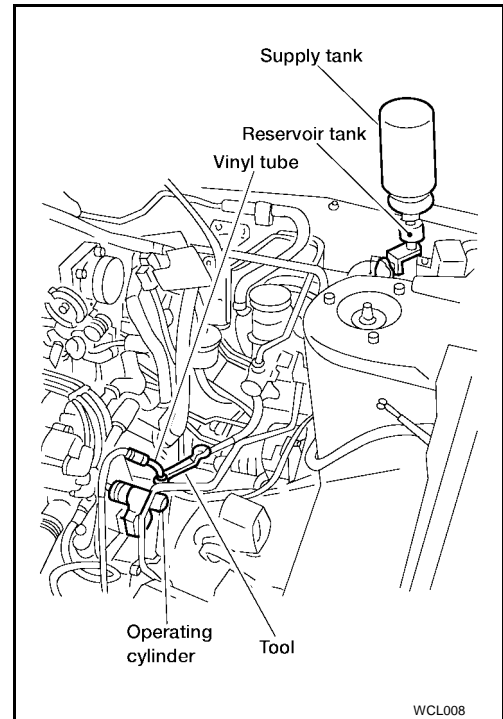

5. Close the air bleeder valve and tighten to specification.

Air bleeder valve : 5.9 - 9.8 N·m (0.6 - 1.0 kg·m, 52 - 87 in·lb)

6. Release the clutch pedal and wait at least 5 seconds.
7. Repeat steps 3 through 6 above until no more air bubbles are in the brake fluid coming out of the vinyl tube attached to the air bleeder valve.

CLUTCH MASTER CYLINDER

Components

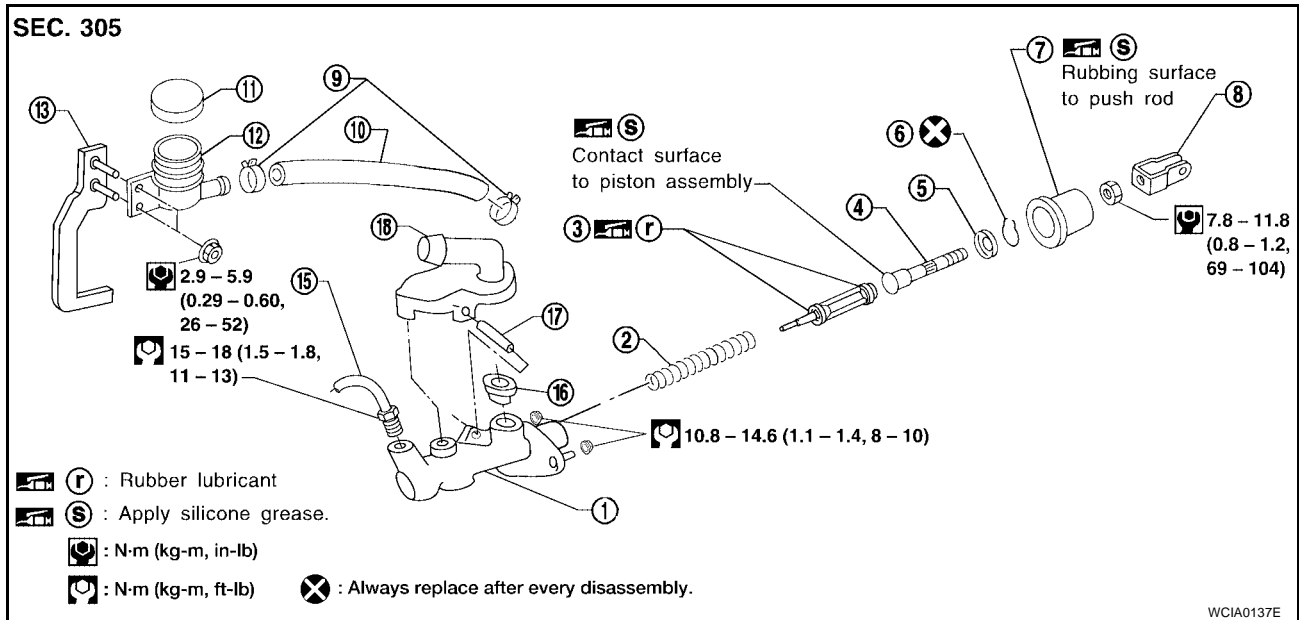

- | | | |
|--------------------|-------------------------------------|--------------------------|
| 1. Cylinder body | 2. Return spring | 3. Piston assembly seals |
| 4. Push rod | 5. Stopper | 6. Stopper ring |
| 7. Dust cover | 8. Clevis | 9. Hose clamps |
| 10. Reservoir hose | 11. Reservoir cap | 12. Reservoir tank |
| 13. Bracket | 14. Clutch damper (not serviceable) | 15. Clutch tube |
| 16. Seal | 17. Pin | 18. Nipple |

Removal

ECS005RQ

1. Drain the brake fluid from the clutch hydraulic system.

CAUTION:

Be careful not to splash brake fluid on painted areas; it may cause paint damage. If brake fluid is splashed on painted areas, wash it away with water immediately.

2. Remove the clutch tube flare nut using a flare nut wrench.
3. Remove the reservoir hose.
4. Remove the snap pin from the clevis pin and remove the clutch pedal from the clevis.
5. Remove the master cylinder assembly mounting nuts and reservoir tank bracket mounting nuts to remove master cylinder assembly.

Disassembly

ECS005RS

1. Loosen the push rod lock nut "A" to remove the clevis and the lock nut "A".
2. Remove the dust cover.
3. Remove the stopper ring and stopper, then remove the push rod from the cylinder body. During removal, keep the push rod depressed, to prevent the piston inside the master cylinder from popping out.

NOTE:

Discard the stopper ring and use a new ring for assembly.

4. Remove the piston assembly from the cylinder body.
5. Remove the return spring.
6. Remove the pin using a pin punch, then remove the nipple and seal.

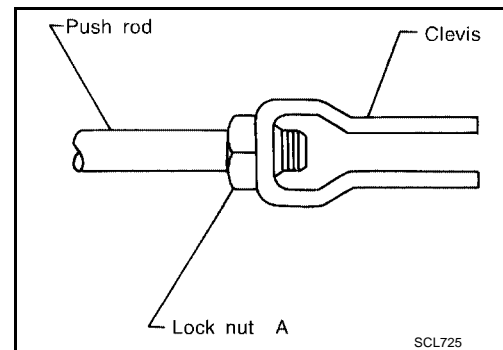

SCL725

Inspection

Inspect for the following conditions and replace any parts as necessary.

- Damage, wear, rust, and pinholes on the cylinder inner wall
- Damage and deformation of the reservoir tank
- Weak return spring
- Crack or deformation of the dust cover

Assembly

1. Install the return spring.
2. Apply rubber lubricant to the sliding parts of the piston assembly, and insert the piston assembly into the cylinder body.
3. After installing the stopper to push rod, install a new stopper ring while keeping the piston assembly depressed by hand, so that the piston assembly will not pop out.

CAUTION:

The stopper ring cannot be reused. Always use a new stopper ring for assembly.

4. Apply silicone grease, and install the dust cover.
5. Install the clevis to push rod, and tighten lock nut "A" to specification.

**Lock nut "A" : 7.8 - 11.8 N·m (0.8 - 1.2 kg·m,
69 - 104 in·lb)**

6. Install the seal and nipple to the cylinder body, and install the pin using a pin punch.

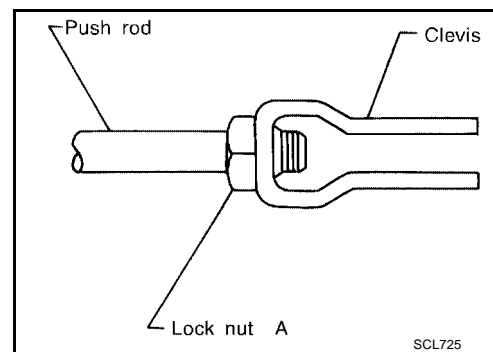

Installation

1. Install the reservoir hose.
2. Connect the clutch tube to the master cylinder assembly, and hand-tighten the flare nut.
3. Install the master cylinder assembly to the cowl, and tighten the mounting nuts to specification.

Master cylinder mounting nuts : 10.8 - 14.6 N·m (1.1 - 1.4 kg·m, 8 - 10 ft·lb)

4. Tighten the reservoir tank bracket mounting nuts to specification.

Reservoir tank bracket mounting nuts : 2.9 - 5.9 N·m (0.29 - 0.60 kg·m, 26 - 52 in·lb)

5. Tighten the clutch tube flare nut to specification, using a flare nut torque wrench.

Clutch tube flare nut : 15 - 18 N·m (1.5 - 1.8 kg·m, 11 - 13 ft·lb)

6. After installing the clevis pin, install the snap pin to connect the clutch pedal to the push rod.
7. After finishing the component installation, bleed the air from the clutch hydraulic system. Refer to [CL-7, "BLEEDING PROCEDURE"](#).

OPERATING CYLINDER

Components

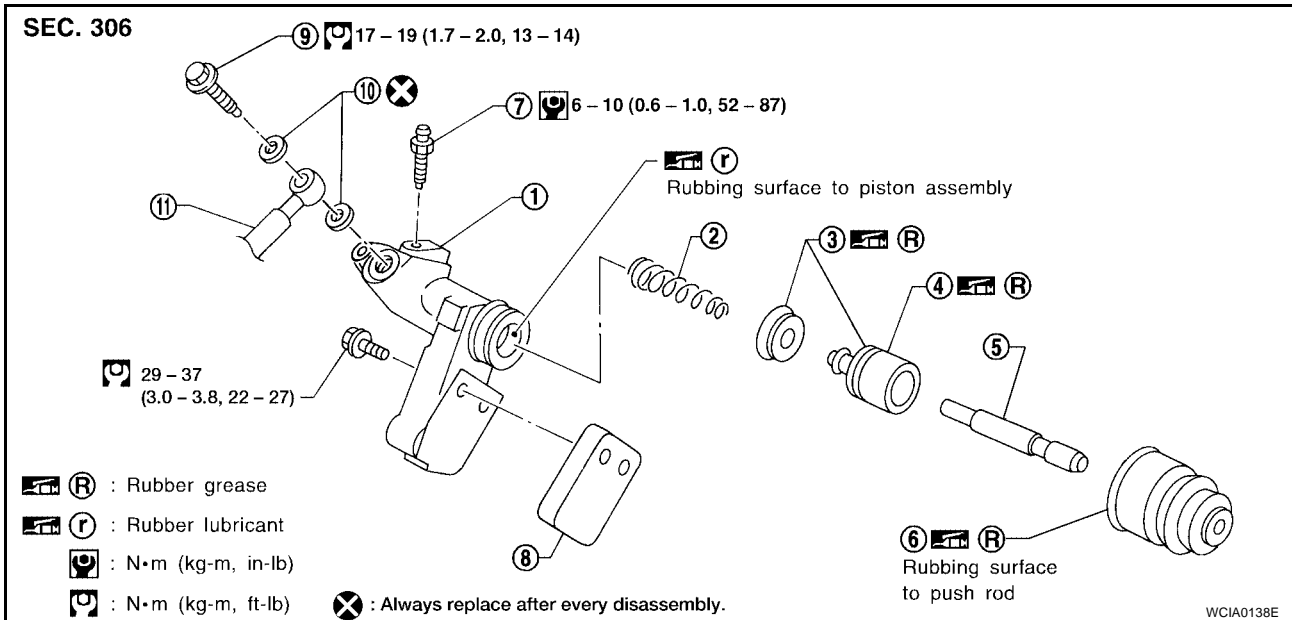

- | | | |
|-------------------|------------------|---------------|
| 1. Cylinder body | 2. Piston spring | 3. Piston cup |
| 4. Piston | 5. Push rod | 6. Dust cover |
| 7. Air bleeder | 8. Spacer | 9. Union bolt |
| 10. Copper washer | 11. Clutch hose | |

Removal

ECS005RW

1. Drain the brake fluid from the clutch hydraulic system.

CAUTION:

Be careful not to splash brake fluid on painted areas; it may cause paint damage. If brake fluid is splashed on painted areas, wash it away with water immediately.

2. Remove the union bolt, the two copper washers, and the clutch hose from the operating cylinder. Discard the copper washers.
3. Remove the operating cylinder bolts, and remove the operating cylinder.

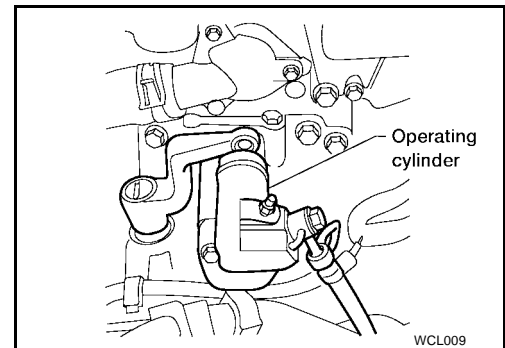

Disassembly

ECS005RX

1. Remove the dust cover from the operating cylinder body.
2. Remove the push rod.
3. Remove the piston.
4. Remove the piston cup.
5. Remove the piston spring.
6. Remove the air bleeder.

Inspection

ECS005RY

Inspect for the following, and replace any parts as necessary.

- Damage, foreign material, wear, rust, and pinholes on the cylinder inner surface, piston, and sliding part of piston cup

- Weak piston spring
- Crack or deformation of dust cover

Assembly

ECS005RZ

CAUTION:

To assemble the operating cylinder use the specified rubber grease and rubber lubricant. Refer to [GL-44, "RECOMMENDED CHEMICAL PRODUCTS AND SEALANTS"](#) .

1. Apply rubber lubricant to the overall inside surface of the operating cylinder body.
2. Install the air bleeder, tighten to specification.

Air bleeder : 6 - 10 N-m (0.6 - 1.0 kg-m, 52 - 87 in-lb)

3. Install the piston spring with the tapered spring end pointing toward the piston cup.
4. Apply rubber grease and install the piston cup.
5. Apply rubber grease and install the piston.
6. Install the push rod.
7. Apply rubber grease and install the dust cover.

Installation

ECS005S0

Installation is in the reverse order of removal.

CAUTION:

- Install the clutch hose without twisting it.
- The two copper washers for the union bolt cannot be reused. Use two new copper washers for installation.
- After finishing the installation, bleed the air from the clutch hydraulic system. Refer to [CL-7, "BLEEDING PROCEDURE"](#) .

PIPING

Removal

1. Remove the engine air cleaner and air duct.
2. Drain the brake fluid from the clutch hydraulic system.

CAUTION:

Be careful not to splash brake fluid on painted areas, it may cause paint damage. If brake fluid is splashed on painted areas, wash it away with water immediately.

3. Remove the flare nut from the operating cylinder body using a flare nut wrench.
4. Remove the union bolt and two copper washers attaching the clutch hose from the operating cylinder. Discard the two copper washers.
5. Remove the clutch hose from the bracket by removing the lock plate.

Installation

1. When installing the clutch hose into the bracket, position the lock plate in the specified direction as shown to secure the clutch hose.

CAUTION:

Install the clutch hose without twisting or bending it.

2. Tighten the flare nut to specification, using a flare nut wrench.

Flare nut : 15 - 18 N·m (1.5 - 1.8 kg·m, 11 - 13 ft·lb)

CAUTION:

Be careful not to damage the flare nut and clutch tube.

3. Position the clutch hose and install the union bolt and two new copper washers on to the operating cylinder, and tighten the union bolt to specification.

Union bolt : 17 - 19 N·m (1.7 - 2.0 kg·m, 13 - 14 ft·lb)

4. Bleed the air from the clutch hydraulic system. Refer to [CL-7, "BLEEDING PROCEDURE"](#) .
5. Install the engine air cleaner and air duct.

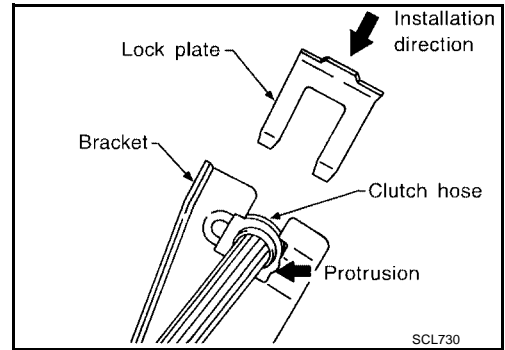

A
B
CL
D
E
F
G
H
I
J
K
L
M

CLUTCH RELEASE MECHANISM

PF3:30502

Components

ECS005S3

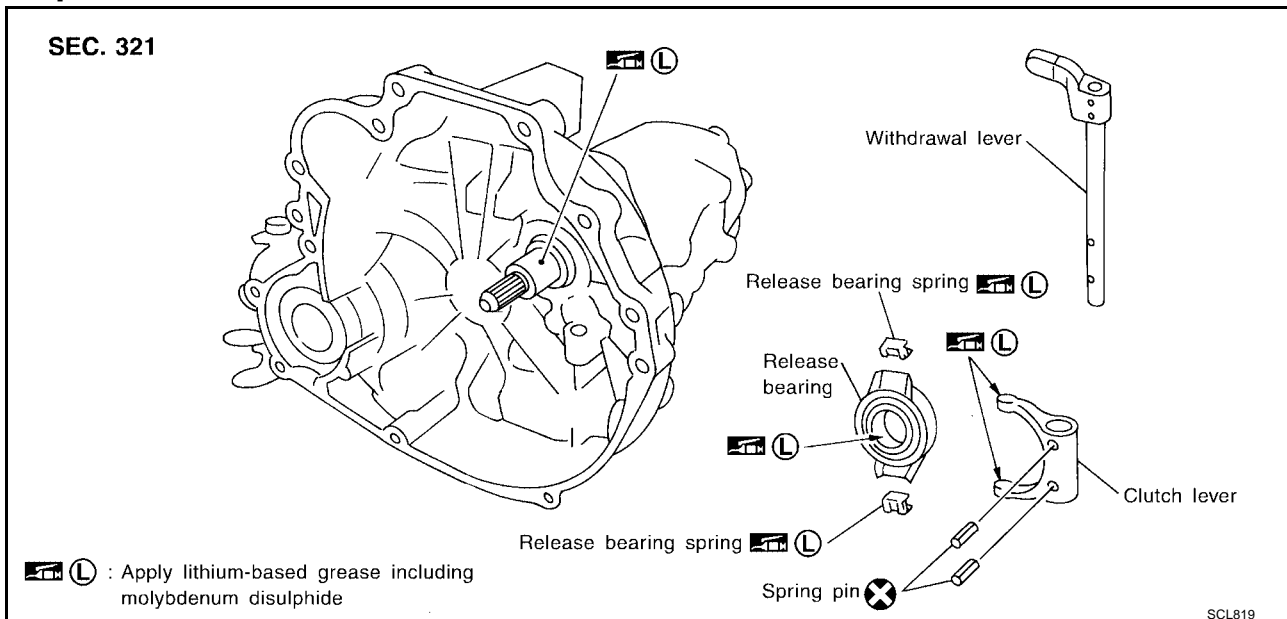

Removal

ECS005S4

1. Remove the manual transaxle. Refer to [MT-16, "Removal and Installation"](#) for RS5F70A, [MT-82, "Removal and Installation"](#) for RS5F51A, or [MT-143, "Removal and Installation"](#) for RS6F51H.
2. Move the withdrawal lever enough to remove the release bearing and release bearing spring, and remove the release bearing from the clutch lever.
3. Support the clutch lever claws with an appropriate wood block, align the retaining pin with "A" as shown, and drive out the spring pins using a pin punch.
4. Pull out the withdrawal lever and remove the clutch lever from the clutch housing.

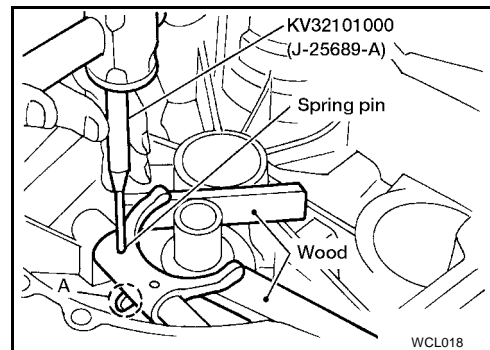

Inspection

ECS005S5

- Replace the release bearing if it is seized, damaged, faulty in rotation direction, or has poor alignment.
- Replace the withdrawal lever if the contact surface is worn excessively.
- Replace the clutch lever if its contact surface is worn excessively.

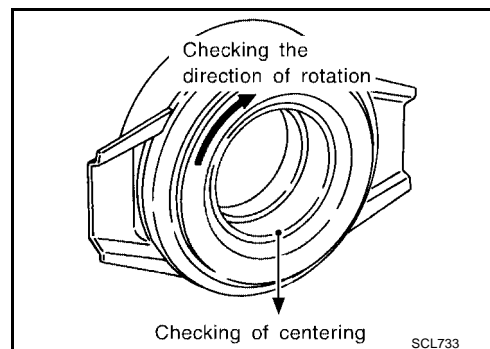

Installation

ECS005S6

CAUTION:

- Apply grease to the clutch components. Otherwise, abnormal noise, poor clutch disengagement, or clutch damage may occur. Wipe the excess grease off completely, as it may cause the clutch components to slip and shudder.
- Keep the clutch disc facing, pressure plate, and flywheel free of oil and grease.

CLUTCH RELEASE MECHANISM

[QG18DE]

- Clean any old grease and abrasive materials off of the grease application areas as shown.
- Apply approximately a 1 mm (0.04 in) thick coating of clutch sleeve grease evenly on the sliding part of the clutch lever and the release bearing spring.
- Apply just enough clutch sleeve grease to fill up the release bearing inner groove.
- Apply the clutch grease to the clutch disc and the input shaft spline. Install the clutch disc to the input shaft, remove the excess grease around the shaft, and remove the clutch disc.
- Lightly and evenly apply the clutch sleeve grease on the sliding part of the release bearing. Install the release bearing and remove any excess grease around the bearing, then remove the release bearing.

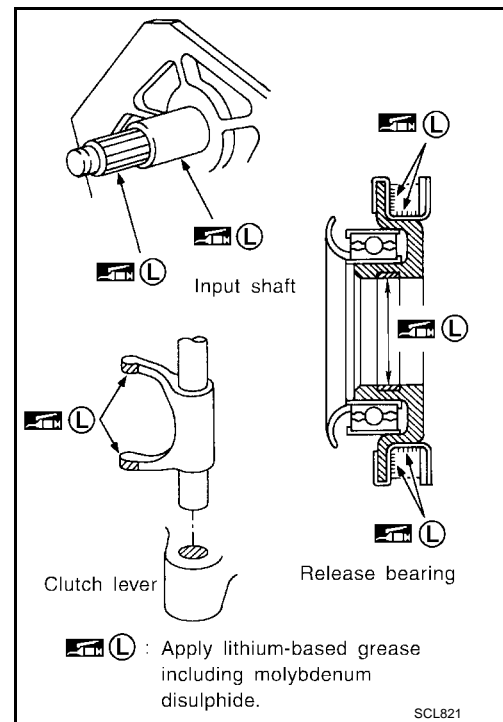

1. Assemble the clutch lever to clutch housing, and insert the withdrawal lever.
2. Support the clutch lever claws with an appropriate wood block, and install new spring pins using a pin punch as shown.

CAUTION:

Spring pins cannot be reused.

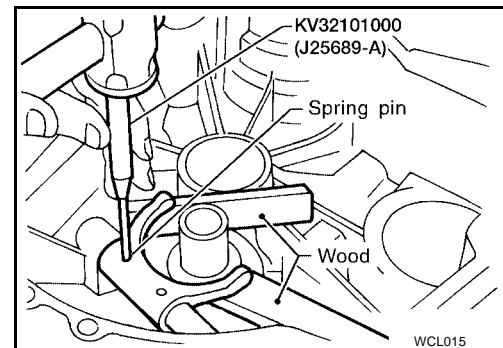

3. Install the release bearing springs on to the release bearing as shown.

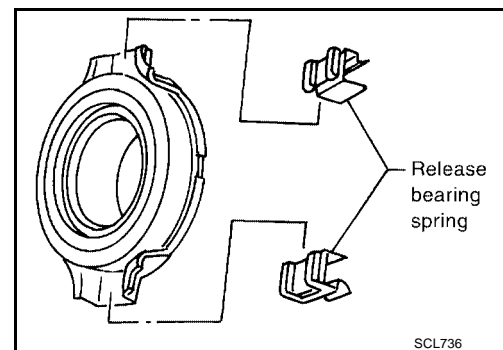

A
B
CL
D
E
F
G
H
I
J
K
L
M

CLUTCH RELEASE MECHANISM

[QG18DE]

4. Operate the withdrawal lever manually, press the clutch spring from both sides, and install the release bearing on to the clutch lever securely.

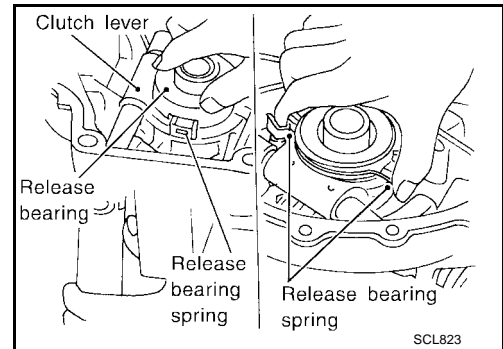

5. Make sure a click is heard when the release bearing spring is pressed from both sides.
6. Make sure all parts operate smoothly when operating the withdrawal lever.

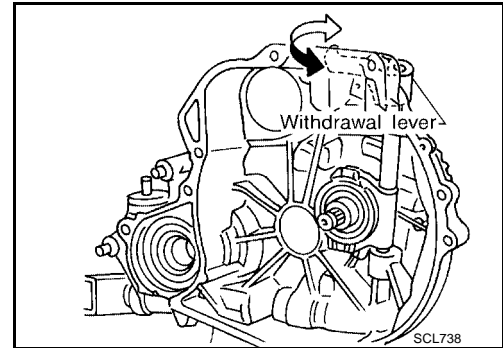

7. Install the manual transaxle. Refer to [MT-16, "Removal and Installation"](#) for RS5F70A, [MT-82, "Removal and Installation"](#) for RS5F51A, or [MT-143, "Removal and Installation"](#) for RS6F51H.

CAUTION:

Remove any excess grease.

CLUTCH DISC, CLUTCH COVER AND FLYWHEEL

PFP:30100

Components

ECS005S7

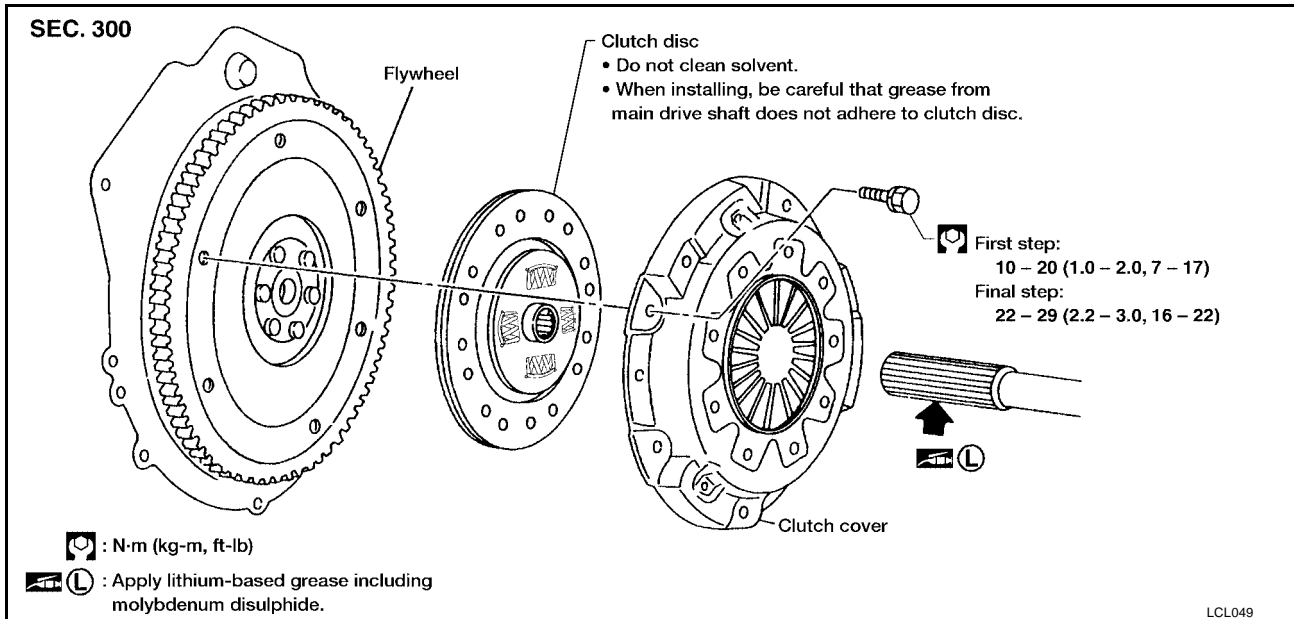

NOTE:

The following operations are with manual transaxle removed.

Inspection and Adjustment

CLUTCH DISC

ECS005S8

- Check the clutch disc for wear on the facing surface at the rivets as shown.

Wear limit of facing surface to rivet head : 0.3 mm (0.012 in)

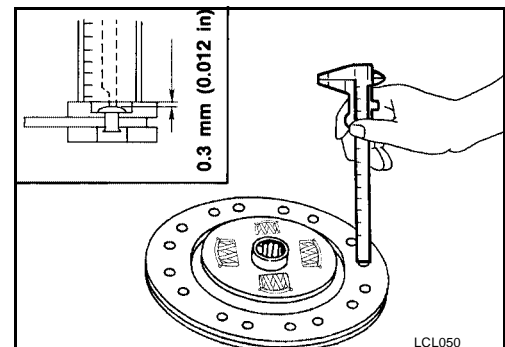

- Check the clutch disc for backlash on the spline and runout on the facing.

Maximum backlash of spline (at outer edge of disc) : 0.9 mm (0.035 in)

Runout limit : 1.0 mm (0.039 in)

Distance of runout check point (from hub center) : 102.5 mm (4.04 in)

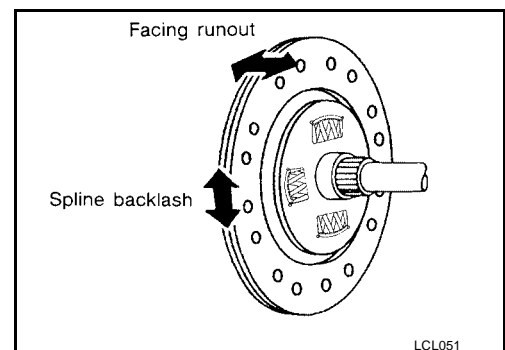

- Check the clutch disc for burns, discoloration, and oil or grease leakage. Replace if necessary.

CLUTCH COVER AND FLYWHEEL

- Check the clutch cover installed for unevenness of the diaphragm spring toe heights.

Uneven limit : 0.88 mm (0.0346 in)

If the toe heights are greater than the uneven limit, adjust the height with Tool as shown.

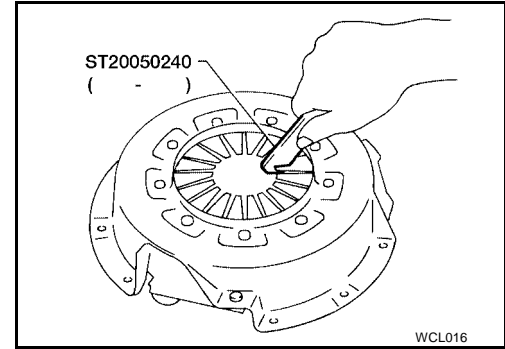

FLYWHEEL INSPECTION

- Check the contact surface of flywheel for slight burns or discoloration. Clean the flywheel contact surface with emery paper.
- Check the flywheel runout using a dial gauge as shown.

Maximum allowable runout : Refer to [EM-77. "Flywheel Runout"](#).

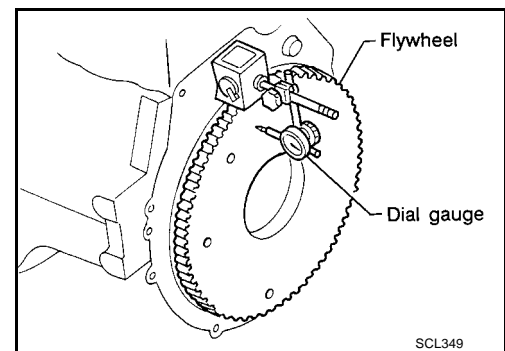

Installation

- Insert Tool into clutch disc hub for proper alignment when installing the clutch cover and disc as shown.

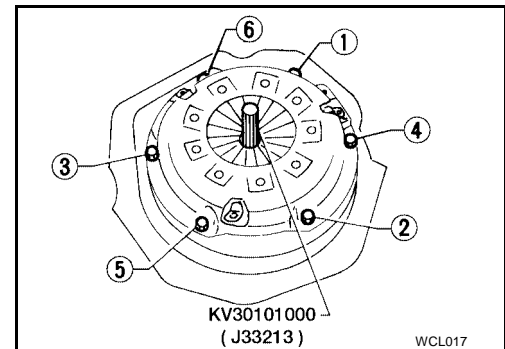

- Tighten the clutch cover bolts in the numerical order as shown, in two steps.

First step : 10 - 20 N·m (1.0 - 2.0 kg·m, 7 - 14 ft·lb)

Final step : 22 - 29 N·m (2.2 - 3.0 kg·m, 16 - 22 ft·lb)

CAUTION:

Do not to allow grease to contaminate the clutch facing.

SERVICE DATA AND SPECIFICATIONS (SDS)

[QG18DE]

SERVICE DATA AND SPECIFICATIONS (SDS)

PF0:00030

Clutch Control System

ECS005SA

Type of clutch control	Hydraulic
------------------------	-----------

Clutch Master Cylinder

ECS005SB

Unit: mm (in)

Inner diameter	15.87 (5/8)
----------------	-------------

Clutch Operating Cylinder

ECS005SC

Unit: mm (in)

Inner diameter	19.05 (3/4)
----------------	-------------

Clutch Disc

ECS005SD

Unit: mm (in)

Engine model	QG18DE
Model	215
Facing size (Outer dia. × inner dia. × thickness)	215 × 145 × 3.5 (8.46 × 5.71 × 0.138)
Thickness of disc assembly with load	7.7 - 8.3 (0.303 - 0.327) with 4,900 N (499.8 kg, 1,101.5 lb)
Wear limit of facing surface to rivet head	0.3 (0.012)
Runout limit of facing	1.0 (0.039)
Distance of runout check point (from the hub center)	102.5 (4.04)
Maximum backlash of spline (at outer edge of disc)	0.9 (0.035)

Clutch Cover

ECS005SE

Unit: mm (in)

Engine model	QG18DE
Model	215
Full-load	4,900 N (499.8 kg, 1,101.5 lb)
Uneven limit of diaphragm spring toe height	0.88 (0.0346)

Clutch Pedal

ECS005SF

Unit: mm (in)

Clearance "C" between pedal stopper rubber and clutch interlock switch threaded end while clutch pedal is fully depressed.	0.1 - 1.0 (0.004 - 0.039)
--	---------------------------

PRECAUTIONS

Precautions

- Recommended fluid is brake fluid “DOT 3”.
- Do not reuse drained brake fluid.
- Be careful not to splash brake fluid on painted areas; it may cause paint damage. If brake fluid is splashed on painted areas, wash it away with water immediately.
- Use a flare nut wrench when removing or installing the clutch hydraulic tubes.
- Use new brake fluid to clean or wash all parts of the master cylinder and operating cylinder.
- Never use mineral oils such as gasoline or kerosene. It will ruin the rubber parts of the hydraulic system.

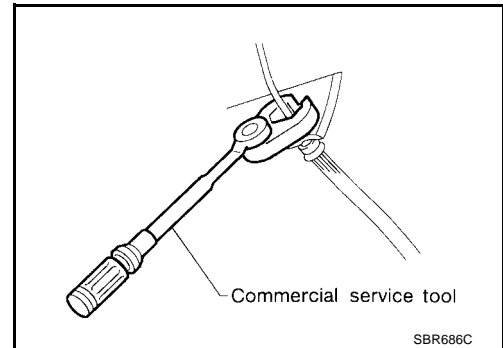

WARNING:

After cleaning the clutch disc, wipe it with a dust collector. Do not use compressed air.

PREPARATION

[QR25DE]

PF0:00002

PREPARATION

Special Service Tools

ECS005SH

The actual shapes of Kent-Moore tools may differ from those of special service tools illustrated here.

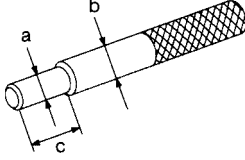
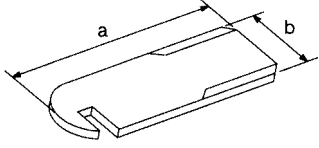
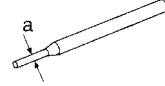
Tool number (Kent-Moore No.) Tool name	Description
ST2063000 (J26366) Clutch aligning bar	 Installing clutch cover and clutch disc a: 15.8 mm (0.622 in) dia. b: 22.9 mm (0.902 in) dia. c: 45 mm (1.772 in)
ST20050240 (—) Diaphragm spring adjusting wrench	 Adjusting unevenness of diaphragm spring of clutch cover a: 150 mm (5.91 in) b: 25 mm (0.98 in)
KV32101000 (J25689-A) Pin punch	 Removing and installing spring pin a: 4 mm (0.16 in) dia.

Commercial Service Tools

ECS005SI

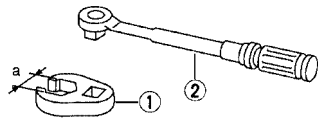
Tool name	Description
1 Flare nut crowfoot 2 Torque wrench	 Removing and installing clutch piping a: 10 mm (0.39 in)

NOISE, VIBRATION, AND HARSHNESS (NVH) TROUBLESHOOTING

[QR25DE]

NOISE, VIBRATION, AND HARSHNESS (NVH) TROUBLESHOOTING

PF0:00003

NVH Troubleshooting Chart

ECS005SJ

Use the chart below to help you find the cause of the symptom. The numbers indicate the order of inspection. Check each part in order. If necessary, repair or replace the parts.

		Suspected parts (possible cause)																Reference page			
		Clutch pedal (inspection and adjustment)	Clutch line (air in line)	Master cylinder piston cup (damaged)	Operating cylinder piston cup (damaged)	Engine mounting (Loose)	Release bearing (worn, dirty or damaged)	Clutch disc (out of true)	Clutch disc (runout is excessive)	Clutch disc (lining broken)	Clutch disc (dirty or burned)	Clutch disc (oily)	Clutch disc (worn out)	Clutch disc (hardened)	Clutch disc (lack of spline grease)	Diaphragm spring (damaged)	Diaphragm spring (out of tip alignment)	Clutch cover (distortion)	Flywheel (distortion)		
Symptom	Clutch grabs/chatters					1															CL-24
	Clutch pedal spongy		1	2	2																CL-24
	Clutch noisy						1														CL-26
	Clutch slips	1										2	2								CL-28
	Clutch does not disengage	1	2	3	4							5	5	5	5	5					EM-63, "Removal and Installation"
																					CL-31
																					CL-33
																					CL-33
																					CL-34
																					CL-34

CLUTCH SYSTEM

Components

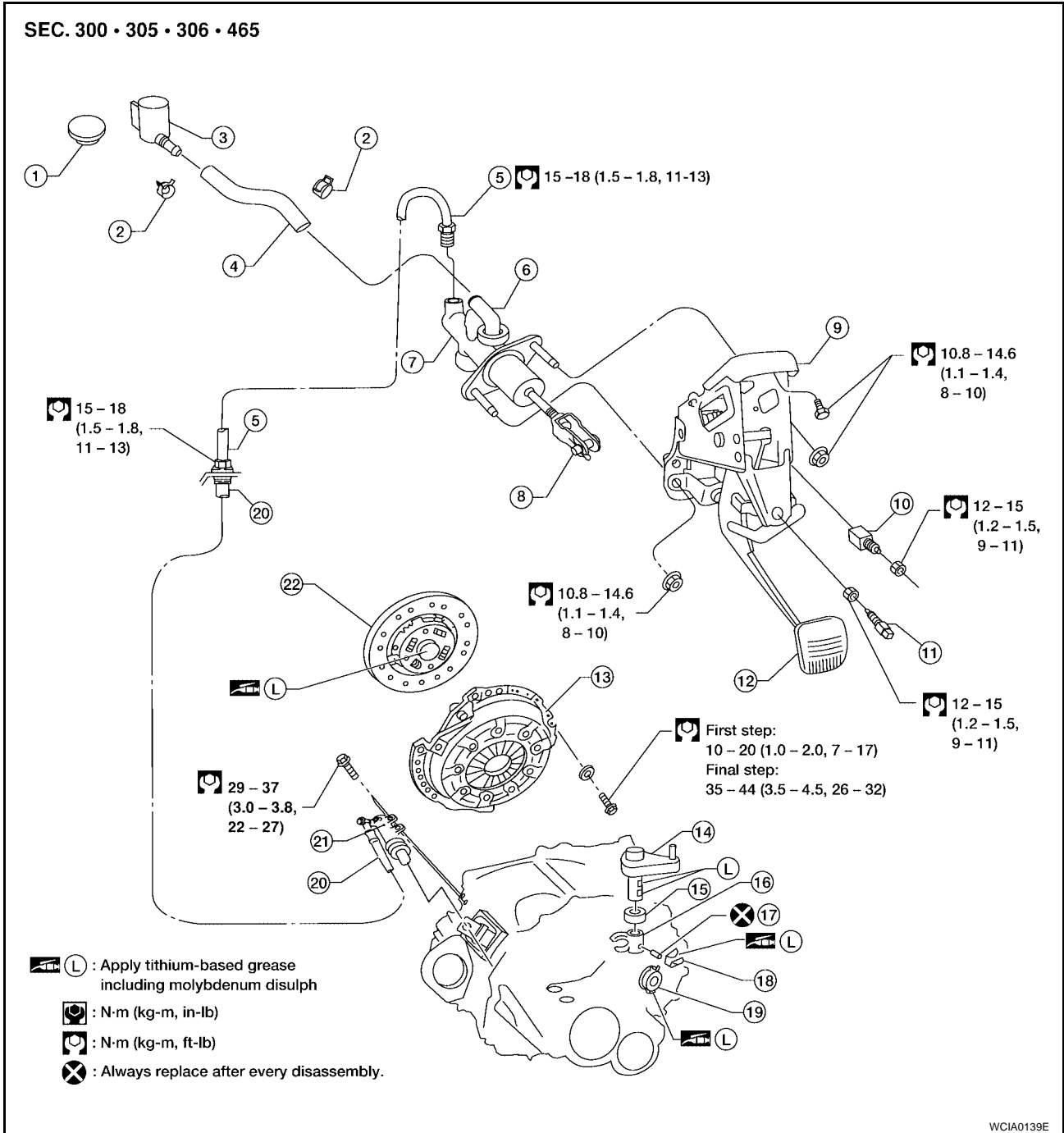

- | | | |
|-----------------------------|--------------------------------------|----------------------------|
| 1. Reservoir cap | 2. Hose clamp | 3. Reservoir tank |
| 4. Reservoir hose | 5. Clutch tube | 6. Nipple |
| 7. Clutch master cylinder | 8. Clevis | 9. Clutch pedal bracket |
| 10. Clutch interlock switch | 11. ASCD clutch switch (if equipped) | 12. Clutch pedal |
| 13. Clutch cover | 14. Withdrawal lever | 15. Spacer |
| 16. Clutch lever | 17. Spring pin | 18. Release bearing spring |
| 19. Release bearing | 20. Clutch hose | 21. Operating cylinder |
| 22. Clutch disc | | |

Inspection and Adjustment

CLUTCH PEDAL INSPECTION AND ADJUSTMENT

1. Check to see if the clutch pedal clevis pin floats freely in the bore of the clutch pedal. It should not be bound by the clevis or clutch pedal.
 - a. If the pin is not free, check that the ASCD switch or pedal stopper bolt is not applying pressure to the clutch pedal causing the pin to bind. To adjust, loosen the ASCD switch or pedal stopper bolt lock nut and turn the ASCD switch or pedal stopper bolt.
 - b. Tighten the lock nut.
 - c. Verify that the clutch pedal clevis pin floats freely in the bore of the clutch pedal. It should not be bound by the clevis or clutch pedal.
 - d. If the pin is still not free, remove the pin and check for deformation or damage. Replace the pin if necessary. Leave the pin removed for step 2.
2. Check the clutch pedal stroke for free range of movement.
 - a. With the clutch pedal clevis pin removed, manually move the pedal up and down to determine if it moves freely.
 - b. If any sticking is noted, replace the related parts (clutch pedal, pedal bracket, assist spring, bushing, etc.). Reassemble the pedal and re-verify that the clevis pin floats freely in the bore of the pedal.
3. Adjust the clearance "C" while fully depressing the clutch pedal (with the clutch interlock switch) as shown.

Clearance "C" : 0.1 - 1.0 mm (0.004 - 0.039 in)

4. Check the clutch hydraulic system components (clutch master cylinder, clutch operating cylinder, Clutch withdrawal lever, clutch release bearing, etc.) for sticking or binding.
 - a. If any sticking or binding is noted, repair or replace the related parts as necessary.
 - b. If the hydraulic system was necessary, bleed the clutch hydraulic system. Refer to [CL-24, "BLEEDING PROCEDURE"](#).

NOTE:

Do not use a vacuum assist or any other type of power bleeder on this system. Use of a vacuum assist or power bleeder will not purge all of the air from the system.

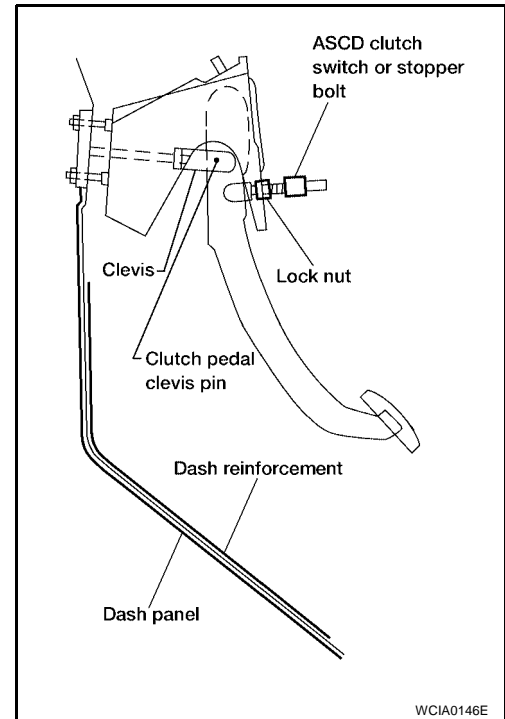

WCIA0146E

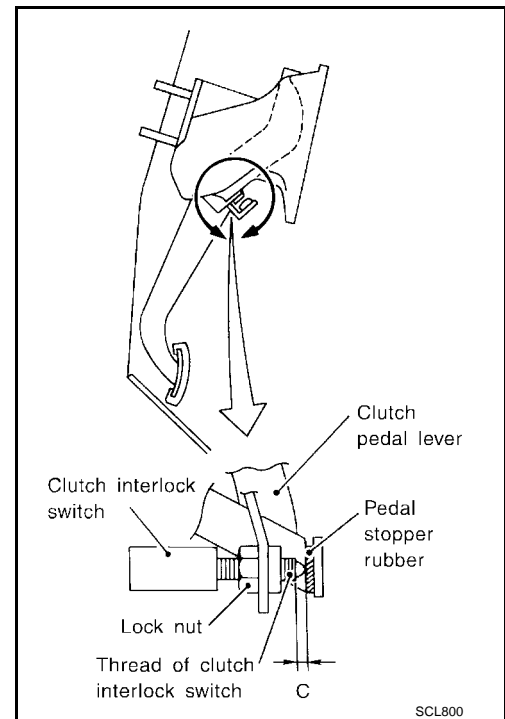

SCL800

BLEEDING PROCEDURE

CAUTION:

Carefully monitor the fluid level at the clutch master cylinder during the bleeding operation.

NOTE:

Do not use a vacuum assist or any other type of power bleeder on this system. Use of a vacuum assist or power bleeder will not purge all of the air from the system.

CLUTCH SYSTEM

[QR25DE]

1. Top off the clutch master cylinder reservoir with the recommended brake fluid "DOT 3". Then attach the additional supply tank as shown.

CAUTION:

Do not to splash brake fluid on painted areas; it may cause paint damage. If brake fluid is splashed on painted areas, wash it away with water immediately.

2. Connect a transparent vinyl tube to the air bleeder valve as shown.
3. Slowly depress the clutch pedal to its full stroke and release it completely. Repeat this operation several times at 2 to 3 seconds intervals.
4. Open the air bleeder valve with the clutch pedal fully depressed.

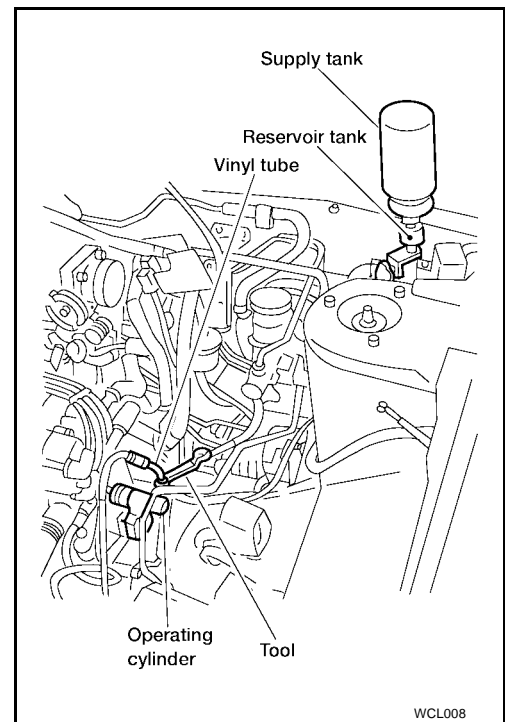

5. Close the air bleeder valve and tighten to specification.

Air bleeder valve : 5.9 - 9.8 N·m (0.6 - 1.0 kg·m, 52 - 87 in·lb)

6. Release the clutch pedal and wait at least 5 seconds.
7. Repeat steps 3 through 6 above until no more air bubbles are in the brake fluid coming out of the vinyl tube attached to the air bleeder valve.

CLUTCH MASTER CYLINDER

PF3:30610

Components

ECS005SM

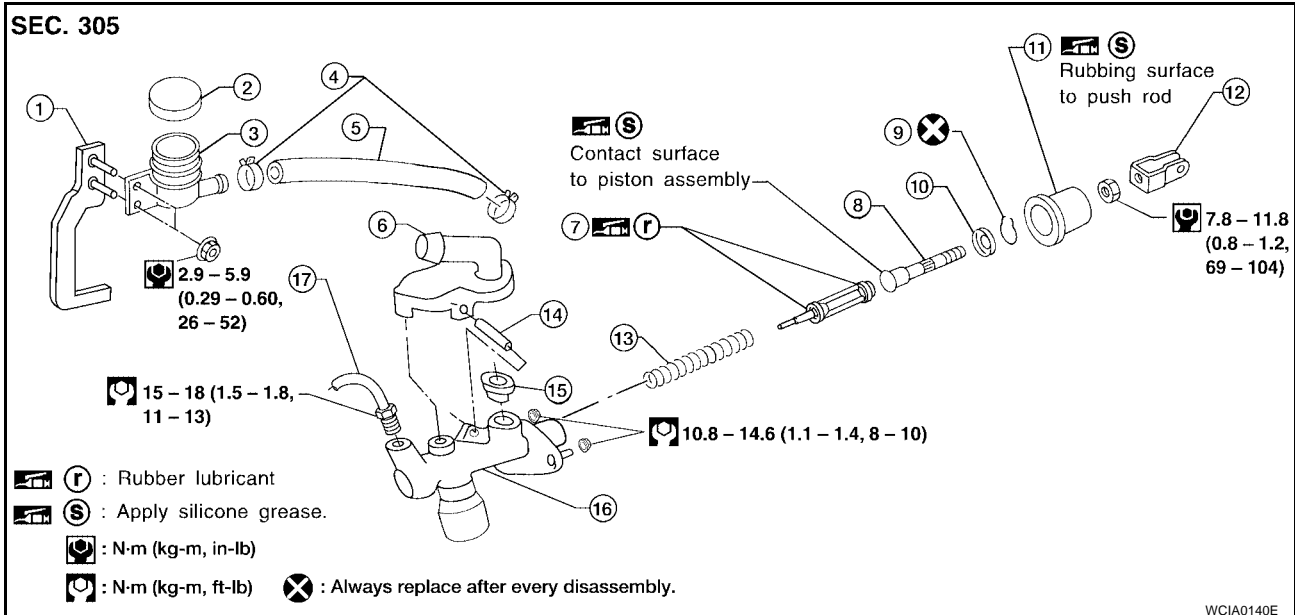

- | | | |
|--------------------------|-------------------|-------------------|
| 1. Bracket | 2. Reservoir cap | 3. Reservoir tank |
| 4. Hose clamps | 5. Reservoir hose | 6. Nipple |
| 7. Piston assembly seals | 8. Push rod | 9. Stopper ring |
| 10. Stopper | 11. Dust cover | 12. Clevis |
| 13. Return spring | 14. Pin | 15. Seal |
| 16. Cylinder body | 17. Clutch tube | |

Removal

ECS005SN

1. Drain the brake fluid from the clutch hydraulic system.

CAUTION:

Be careful not to splash brake fluid on painted areas; it may cause paint damage. If brake fluid is splashed on painted areas, wash it away with water immediately.

2. Remove the clutch tube flare nut using a flare nut wrench.
3. Remove the reservoir hose.
4. Remove the snap pin from the clevis pin and remove the clutch pedal from the clevis.
5. Unscrew the master cylinder assembly nuts and reservoir tank bracket nuts to remove the master cylinder assembly.

Disassembly

ECS005SP

1. Loosen the push rod lock nut "A" to remove the clevis and lock nut "A".
2. Remove the dust cover.
3. Remove the stopper ring and stopper, and remove the push rod from the cylinder body. During removal, keep the push rod depressed, to prevent the piston inside the master cylinder from popping out. Discard the stopper ring.
4. Remove the piston assembly from the cylinder body.
5. Remove the return spring.
6. Remove the pin using a pin punch, then remove the nipple and seal.

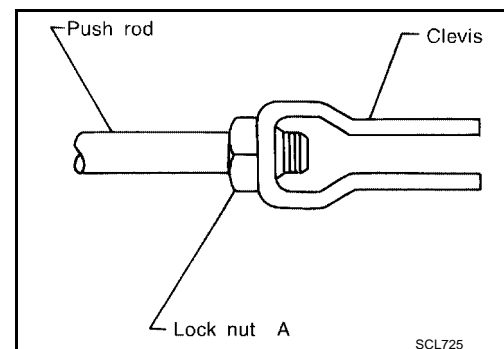

Inspection

ECS005SQ

Inspect for the following, and replace parts if necessary.

- Damage, wear, rust, and pinholes on the cylinder inner wall
- Damage and deformation of the reservoir tank
- Weak spring
- Crack or deformation of the dust cover

A

B

ECS005SR

Assembly

1. Install the return spring.
2. Apply rubber lubricant to the sliding parts of the piston assembly, and insert the piston assembly into cylinder body.
3. After installing the stopper on to the push rod, install the new stopper ring while keeping the piston assembly depressed by hand, so that the piston assembly will not pop out.

CL

D

CAUTION:

The stopper ring cannot be reused. Always use a new stopper ring for assembly.

4. Apply silicone grease to the dust cover and install the dust cover.
5. Install the clevis on to push rod, and tighten the lock nut "A" to specification.

E

Lock nut "A" : 7.8 - 11.8 N·m (0.8 - 1.2 kg-m, 69 - 104 in-lb)

F

6. Install the seal and nipple on to the cylinder body, and install the pin using a pin punch.

Installation

ECS005SO

1. Install the reservoir hose.
2. Connect the clutch tube to the master cylinder assembly, and hand-tighten the flare nut.
3. Install the master cylinder assembly to the cowl, and tighten the nuts to specification.

G

H

Master cylinder nuts : 10.8 - 14.6 N·m (1.1 - 1.4 kg-m, 8 - 10 ft-lb)

4. Tighten reservoir tank bracket nuts to specification.

I

Reservoir tank bracket nuts : 2.9 - 5.9 N·m (0.29 - 0.60 kg-m, 26 - 52 in-lb)

5. Tighten clutch tube flare nut using a flare nut torque wrench to specification.

J

Clutch tube flare nut : 15 - 18 N·m (1.5 - 1.8 kg-m, 11 - 13 ft-lb)

6. After installing the clevis pin, install the snap pin to connect the clutch pedal to the push rod.
7. After finishing the installation, bleed the air out of the clutch hydraulic system. Refer to [CL-24, "BLEEDING PROCEDURE"](#).

K

L

M

OPERATING CYLINDER

Components

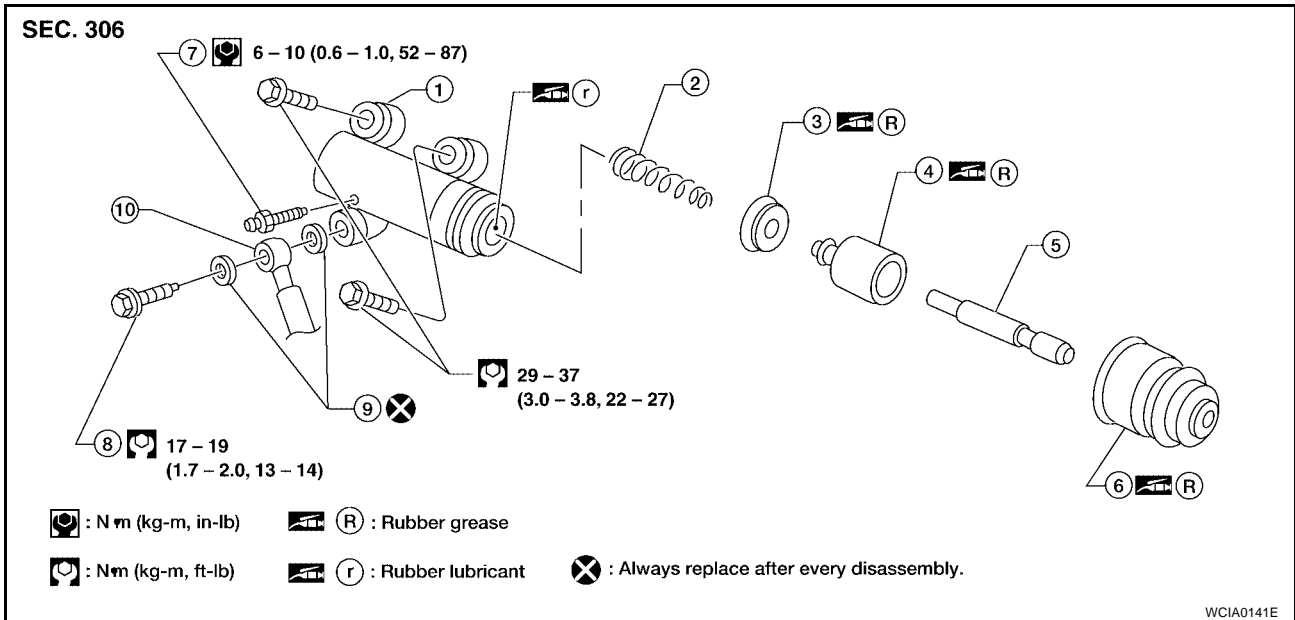

- | | | |
|------------------|------------------|------------------|
| 1. Cylinder body | 2. Piston spring | 3. Piston cup |
| 4. Piston | 5. Push rod | 6. Dust cover |
| 7. Air bleeder | 8. Union bolt | 9. Copper washer |
| 10. Clutch hose | | |

Removal

1. Drain the brake fluid from clutch hydraulic system.
- CAUTION:**
Be careful not to splash brake fluid on painted areas; it may cause paint damage. If brake fluid is splashed on painted areas, wash it away with water immediately.
2. Remove the union bolt, the two copper washers, and the clutch hose from the operating cylinder. Discard the copper washers.
3. Remove the operating cylinder bolts, and remove the operating cylinder.

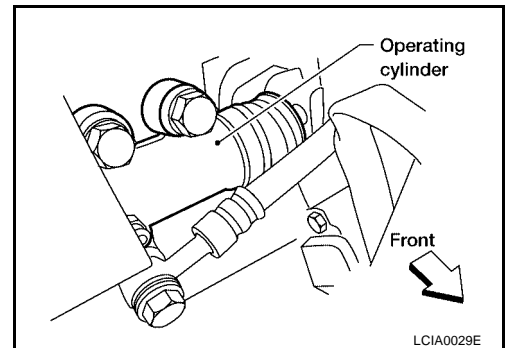

Disassembly

1. Remove the dust cover from the operating cylinder body.
2. Remove the push rod.
3. Remove the piston.
4. Remove the piston cup.
5. Remove the piston spring.
6. Remove the air bleeder.

Inspection

Inspect for the following, and replace parts if necessary.

- Damage, foreign material, wear, rust, and pinholes on the cylinder inner surface, piston, and sliding part of piston cup

- Weak piston spring
- Crack or deformation of dust cover

A

Assembly

ECS005SW

CAUTION:

To assemble the operating cylinder use the specified rubber grease and rubber lubricant. Refer to [GL-44, "RECOMMENDED CHEMICAL PRODUCTS AND SEALANTS"](#) .

B

1. Apply rubber lubricant to the overall inside surface of the operating cylinder body.
2. Install the air bleeder and tighten to specification.

CL

Air bleeder : 6 - 10 N·m (0.6 - 1.0 kg·m, 52 - 87 in·lb)

3. Install the piston spring.
4. Apply rubber grease and install the piston cup.
5. Apply rubber grease and install the piston.
6. Install the push rod.
7. Apply rubber grease and install the dust cover.

D

E

Installation

ECS005SX

Installation is in the reverse order of removal.

CAUTION:

- Install the clutch hose without twisting it.
- The two copper washers for the union bolt cannot be reused. Use two new copper washers for installation.
- After finishing the installation, bleed the air from the clutch hydraulic system. Refer to [CL-24, "BLEEDING PROCEDURE"](#) .

F

G

H

I

J

K

L

M

PIPING

Removal

1. Remove the engine air cleaner and air duct.
2. Drain the brake fluid from the clutch hydraulic system.

CAUTION:

Be careful not to splash brake fluid on painted areas; it may cause paint damage. If brake fluid is splashed on painted areas, wash it away with water immediately.

3. Remove the flare nut from the operating cylinder body using a flare nut wrench.
4. Remove the union bolt and two copper washers attaching the clutch hose from the operating cylinder. Discard the two copper washers.
5. Remove the clutch hose from the bracket by removing the lock plate.

Installation

1. When installing the clutch hose into the bracket, position the lock plate in the specified direction as shown to secure the clutch hose.

CAUTION:

Install the clutch hose without twisting or bending it.

2. Tighten the flare nut to specification, using a flare nut wrench.

Flare nut : 15 - 18 N·m (1.5 - 1.8 kg-m, 11 - 13 ft-lb)

CAUTION:

Be careful not to damage the flare nut and clutch tube.

3. Position the clutch hose and install the union bolt and two new copper washers on to the operating cylinder, and tighten the union bolt to specification.

Union bolt : 17 - 19 N·m (1.7 - 2.0 kg-m, 13 - 14 ft-lb)

4. Bleed the air from the clutch hydraulic system. Refer to [CL-24, "BLEEDING PROCEDURE"](#).
5. Install the engine air cleaner and air duct.

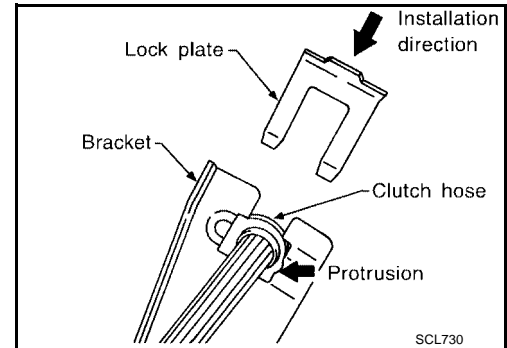

CLUTCH RELEASE MECHANISM

[QR25DE]

CLUTCH RELEASE MECHANISM

PFP:30502

Components

ECS00570

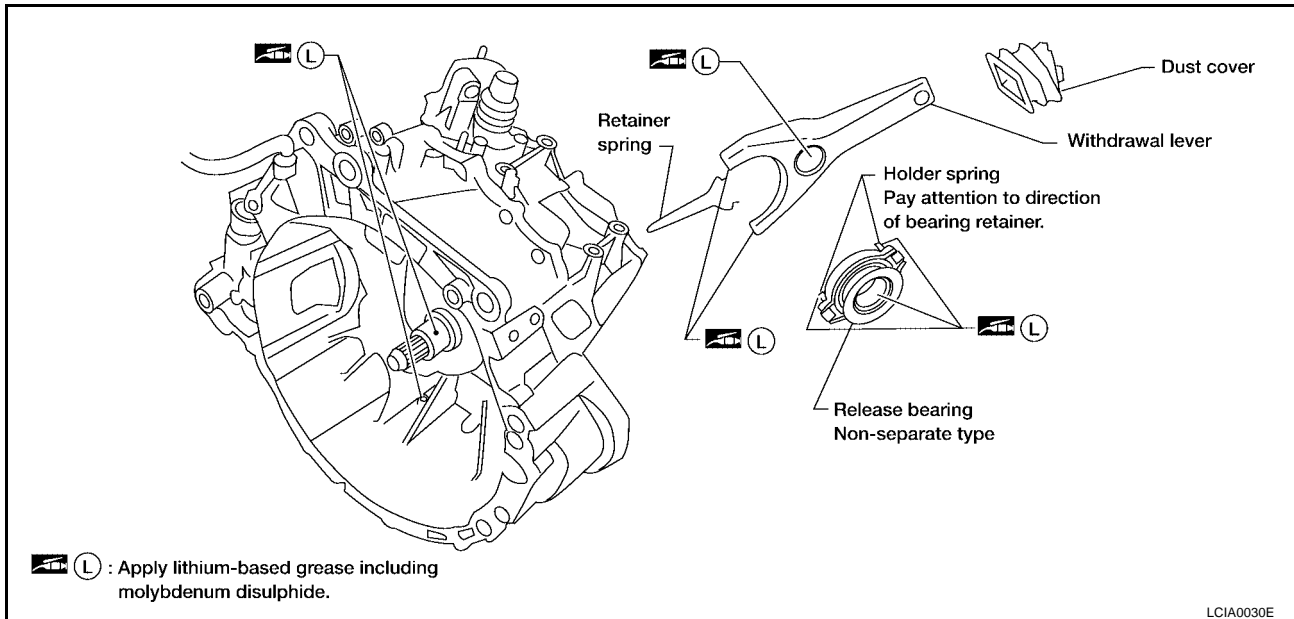

Removal

ECS00571

1. Remove the manual transaxle. Refer to [MT-16, "Removal and Installation"](#).
2. Move the withdrawal lever enough to remove the release bearing, and remove the release bearing from the clutch lever.
3. Remove the withdrawal lever retainer spring.
4. Pull out the withdrawal lever and remove the dust cover.

Inspection After Removal

ECS00572

- Replace the release bearing if it is seized, damaged, faulty in rotation direction, or has poor alignment.
- Replace the withdrawal lever if the contact surface is worn excessively.
- Replace the dust seal if its deformed or cracked.

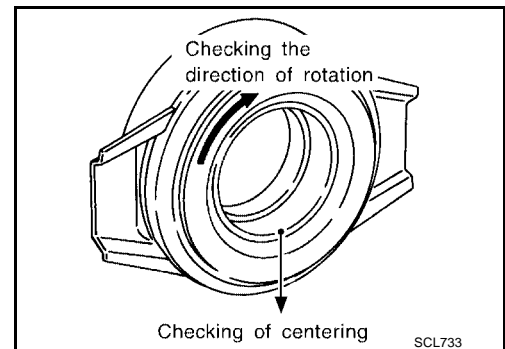

Installation

ECS00573

1. Installation is in the reverse order of removal.

NOTE:

- Clean any old grease and abrasive materials off of the grease application areas as shown.

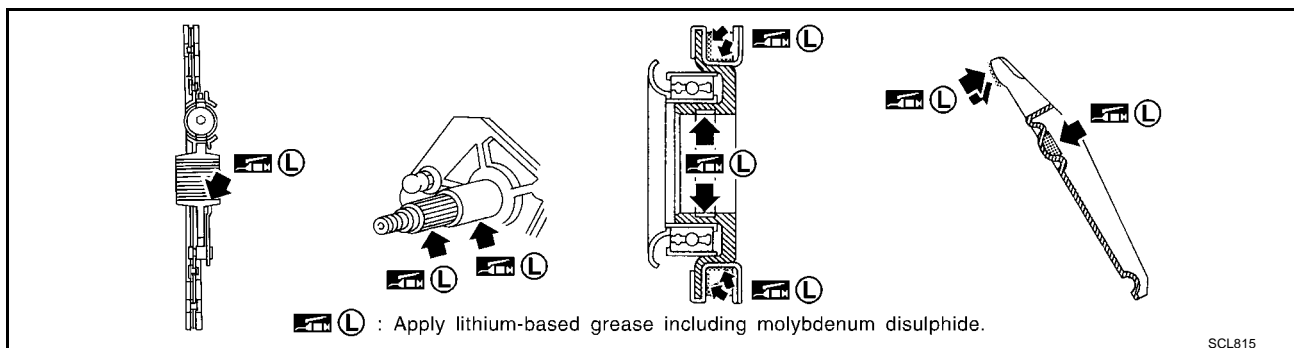

CLUTCH RELEASE MECHANISM

[QR25DE]

-
- Apply approximately a 1 mm (0.04 in) thick coating of clutch sleeve grease to the withdrawal lever and holder spring friction surfaces.
 - Apply a coat of clutch sleeve grease to the grooves on contact surfaces of the withdrawal lever ball pin and inner surface of the release bearing; make sure the grease is flush with the grooves.
 - Apply a thin coat of clutch sleeve grease to the release bearing friction surface. After the grease application, install the release bearing. Wipe off any excess grease forced out from the bearing installation.

CLUTCH DISC, CLUTCH COVER AND FLYWHEEL

PF30100

Components

ECS005T4

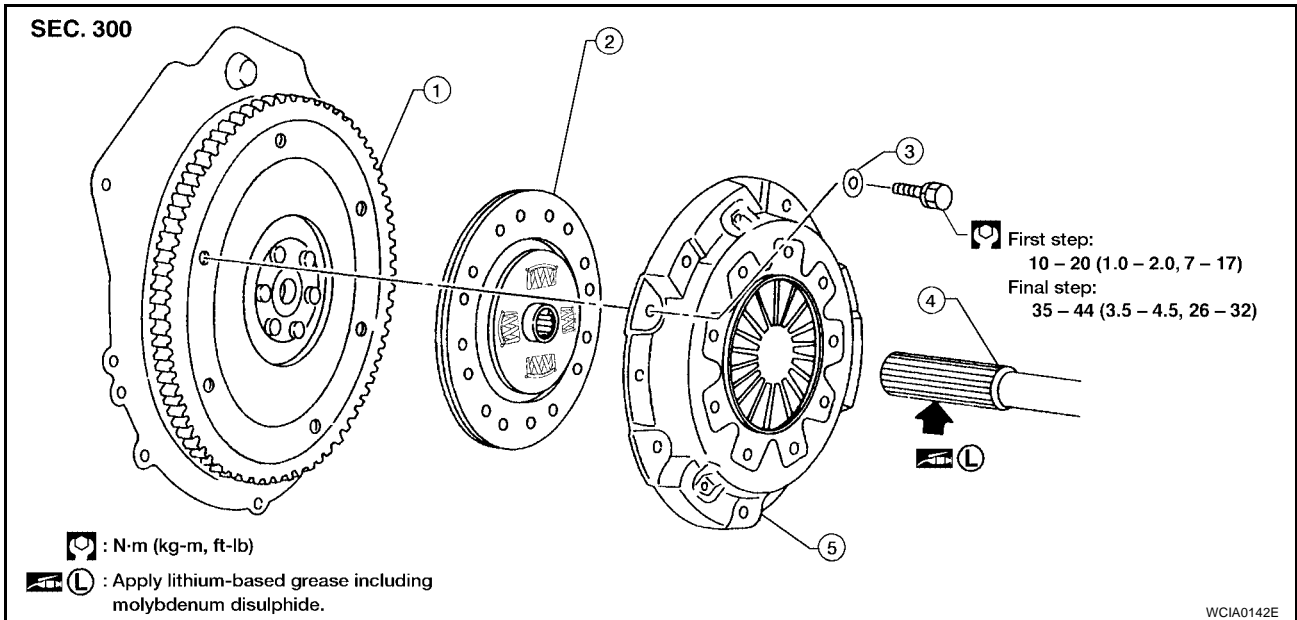

1. Flywheel
2. Clutch disc
3. Washer
4. Main drive shaft
5. Clutch cover

CAUTION:

- Do not clean the clutch disc with solvent.
- When installing the clutch disc, do not allow grease from the main drive shaft to contact the clutch disc friction surface.

Inspection and Adjustment

ECS005T5

NOTE:

The following procedures are done with the manual transaxle removed.

CLUTCH DISC

- Check clutch disc for wear of the facing surface at the rivets as shown.

Wear limit of facing surface to rivet head : 0.3 mm (0.012 in)

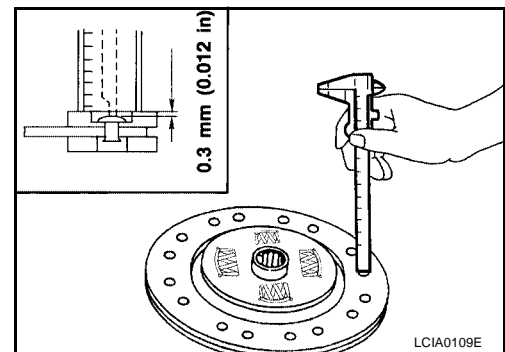

- Check the clutch disc for backlash of the spline and runout of the facing as shown.

Maximum backlash of spline (at outer edge of disc) : 0.9 mm (0.035 in)

Runout limit : 1.0 mm (0.039 in)

Distance of runout check point (from hub center) : 115.0 mm (4.53 in)

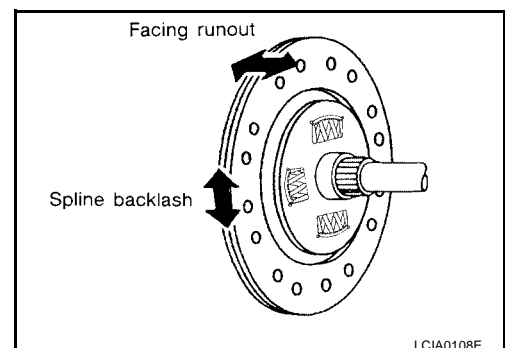

CLUTCH DISC, CLUTCH COVER AND FLYWHEEL

[QR25DE]

- Check the clutch disc for burns, discoloration, or oil and grease leakage. Replace the components as necessary.

CLUTCH COVER AND FLYWHEEL

Check the spring toe height unevenness of the clutch cover with it installed on the vehicle.

Uneven limit : 0.7 mm (0.028 in)

If the measured uneven height is greater than the specified limit, adjust the spring toe height with Tool as shown.

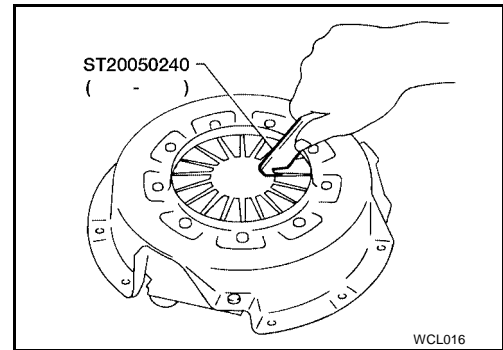

FLYWHEEL INSPECTION

- Check the contact surface of the flywheel for slight burns or discoloration. Clean the flywheel contact surface with emery paper.
- Check the flywheel runout using a dial gauge as shown.

Maximum allowable runout : Refer to EM-182, "MOVEMENT AMOUNT OF FLYWHEEL (M/T MODEL)" .

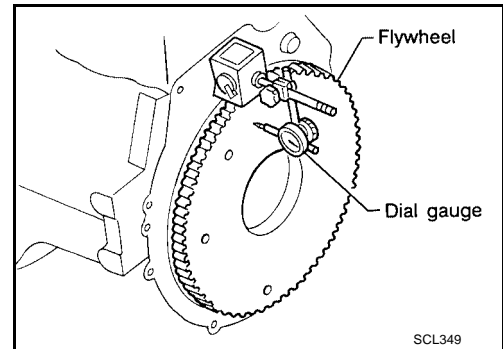

ECS005T6

Installation

1. Insert Tool into the clutch disc hub for correct alignment when installing the clutch cover and disc as shown.

CAUTION:

Do not allow the grease to contaminate the clutch facing.

2. Tighten the bolts in numerical order in two steps.

First step : 10 - 20 N·m (1.0 - 2.0 kg·m, 7 - 14 ft·lb)

Final step : 35 - 44 N·m (3.5 - 4.5 kg·m, 26 - 32 ft·lb)

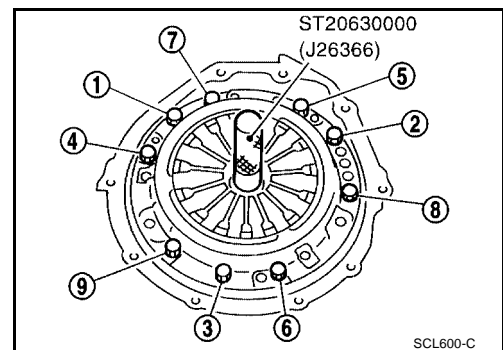

SERVICE DATA AND SPECIFICATIONS (SDS)

[QR25DE]

SERVICE DATA AND SPECIFICATIONS (SDS)

PF0:00030

Clutch Control System

ECS005T7

Type of clutch control	Hydraulic
------------------------	-----------

Clutch Master Cylinder

ECS005T8

Unit: mm (in)

Inner diameter	15.87 (5/8)
----------------	-------------

Clutch Operating Cylinder

ECS005T9

Unit: mm (in)

Inner diameter	19.05 (3/4)
----------------	-------------

Clutch Disc

ECS005TA

Unit: mm (in)

Engine model	QR25DE
Model	240
Facing size (Outer dia. × inner dia. × thickness)	240 × 160 × 3.5 (9.45 × 6.30 × 0.138)
Thickness of disc assembly with load	7.8 - 8.4 (0.307 - 0.331) with 5,884 N (600 kg, 1,322 lb)
Wear limit of facing surface to rivet head	0.3 (0.012)
Runout limit of facing	1.0 (0.039)
Distance of runout check point (from the hub center)	115.0 (4.53)
Maximum backlash of spline (at outer edge disc)	0.9 (0.035)

Clutch Cover

ECS005TB

Unit: mm (in)

Engine model	QR25DE
Model	240
Full-load	5,884 N (600 kg, 1,322 lb)
Uneven limit of diaphragm spring toe height	0.7 (0.028)

Clutch Pedal

ECS005TC

Unit: mm (in)

Clearance "C" between pedal stopper rubber and clutch interlock switch threaded end while clutch pedal is fully depressed.	0.1 - 1.0 (0.004 - 0.039)
--	---------------------------

