

SECTION **SB**
SEAT BELTS

A
B
C
D
E
F
G
SB
I
J
K
L
M

CONTENTS

PRECAUTIONS	2	BASIC INSPECTION	7
Precautions for Supplemental Restraint System (SRS) "AIR BAG" and "SEAT BELT PRE-TENSIONER"	2	Seat Belt Inspection	7
Precaution for Seat Belt Service	2	AFTER A COLLISION	7
AFTER A COLLISION	2	PRELIMINARY CHECKS	7
FRONT SEAT BELT	3	SEAT BELT RETRACTOR ON-VEHICLE CHECK	8
Removal and Installation	3	SEAT BELT RETRACTOR OFF-VEHICLE CHECK	9
REAR SEAT BELT	5	TOP TETHER STRAP CHILD RESTRAINT	10
Removal and Installation	5	Removal and Installation	10
		LATCH (LOWER ANCHORS AND TETHER FOR CHILDREN) SYSTEM	11
		Removal and Installation	11

PRECAUTIONS

PRECAUTIONS

PFP:00001

Precautions for Supplemental Restraint System (SRS) “AIR BAG” and “SEAT BELT PRE-TENSIONER”

EHS000LQ

The Supplemental Restraint System such as “AIR BAG” and “SEAT BELT PRE-TENSIONER”, used along with a front seat belt, helps to reduce the risk or severity of injury to the driver and front passenger for certain types of collision. Information necessary to service the system safely is included in the SRS and SB section of this Service Manual.

WARNING:

- To avoid rendering the SRS inoperative, which could increase the risk of personal injury or death in the event of a collision which would result in air bag inflation, all maintenance must be performed by an authorized NISSAN/INFINITI dealer.
- Improper maintenance, including incorrect removal and installation of the SRS, can lead to personal injury caused by unintentional activation of the system. For removal of Spiral Cable and Air Bag Module, see the SRS section.
- Do not use electrical test equipment on any circuit related to the SRS unless instructed to in this Service Manual. SRS wiring harnesses can be identified by yellow and/or orange harnesses or harness connectors.

Precaution for Seat Belt Service

EHS000J7

CAUTION:

- Before removing the front seat belt pre-tensioner assembly, turn the ignition switch off, disconnect both battery cables and wait at least 3 minutes.
- Do not use electrical test equipment for front seat belt pre-tensioner connector.
- After replacing or reinstalling front seat belt pre-tensioner assembly, or reconnecting front seat belt pre-tensioner connector, check the system function. Refer to [SRS-17, "SRS Operation Check"](#).
- Do not use disassembled buckle or seat belt assembly.
- Replace anchor bolts if they are deformed or worn out.
- Never oil tongue and buckle.
- If any component of seat belt assembly is questionable, do not repair. Replace the whole seat belt assembly.
- If webbing is cut, frayed, or damaged, replace seat belt assembly.
- When replacing seat belt assembly, use a Genuine NISSAN seat belt assembly.

AFTER A COLLISION

WARNING:

Inspect all seat belt assemblies including retractors and attaching hardware after any collision. NISSAN recommends that all seat belt assemblies in use during a collision be replaced unless the collision was minor and the belts show no damage and continue to operate properly. Failure to do so could result in serious personal injury in an accident. Seat belt assemblies not in use during a collision should also be replaced if either damage or improper operation is noted. Seat belt pre-tensioner should be replaced even if the seat belts are not in use during a frontal collision in which the air bags are deployed.

Replace any seat belt assembly (including anchor bolts) if:

- The seat belt was in use at the time of a collision (except for minor collisions and the belts, retractors and buckles show no damage and continue to operate properly).
- The seat belt was damaged in an accident. (i.e. torn webbing, bent retractor or guide, etc.)
- The seat belt attaching point was damaged in an accident. Inspect the seat belt attaching area for damage or distortion and repair as necessary before installing a new seat belt assembly.
- Anchor bolts are deformed or worn out.
- The front seat belt pre-tensioner should be replaced even if the seat belts are not in use during the collision in which the air bags are deployed.

FRONT SEAT BELT

PFP:86880

EHS000J8

FRONT SEAT BELT

Removal and Installation

1. Disconnect both battery cables.
2. Slide the seat all the way forward and tilt the seat back toward the front.
3. Remove adjuster cover. **A**
4. Remove floor anchor bolt. **B**
5. Remove shoulder anchor bolt. **C**
6. Remove center pillar upper and lower garnish. Refer to [EI-28, "SIDE AND FLOOR TRIM"](#) for details.
7. Disconnect front seat belt pre-tensioner connector.
 - For removal/installation of the direct-connect SRS connectors, refer to [SRS-6, "Direct-connect SRS Component Connectors"](#).
8. Remove the screw securing front seat belt pre-tensioner retractor, then remove seat belt and seat belt pre-tensioner retractor.
9. Remove bolts securing seat belt adjuster, then remove seat belt adjuster.

SEC. 769•868

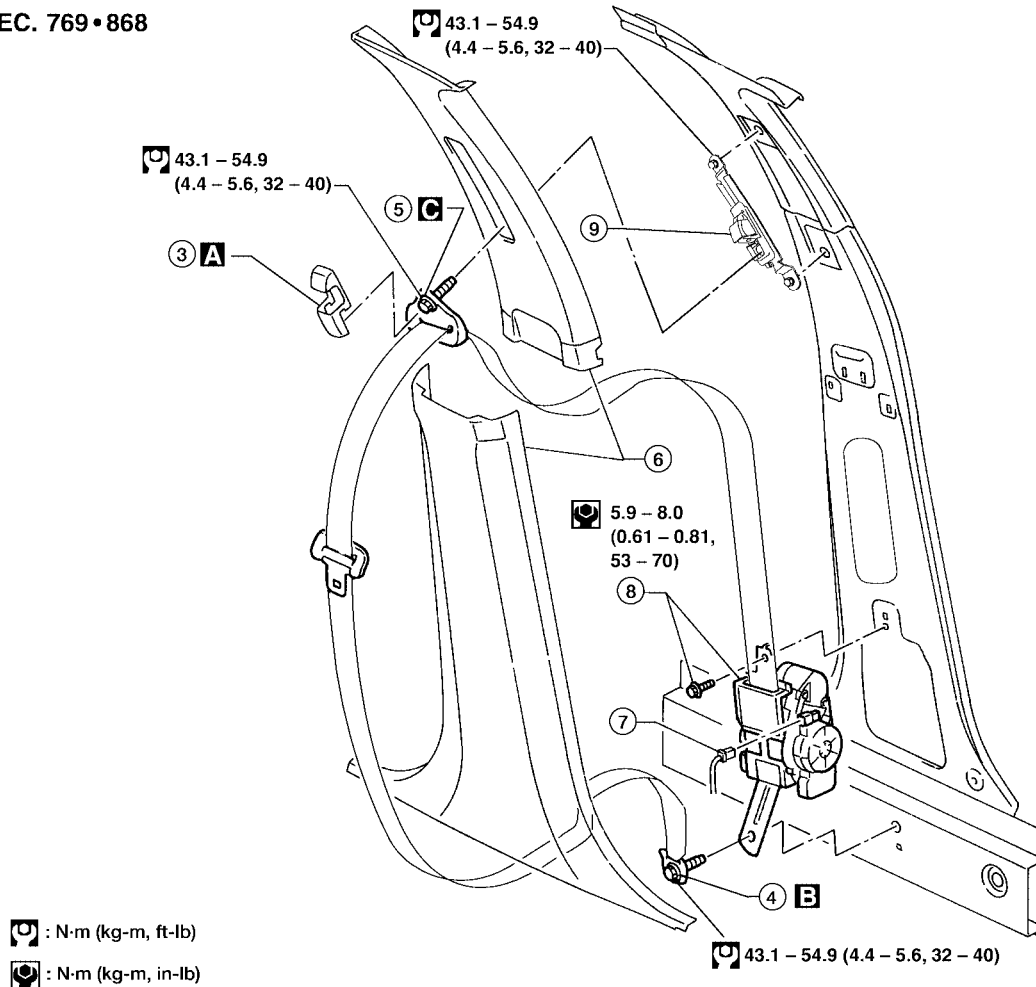

WHIA0059E

FRONT SEAT BELT

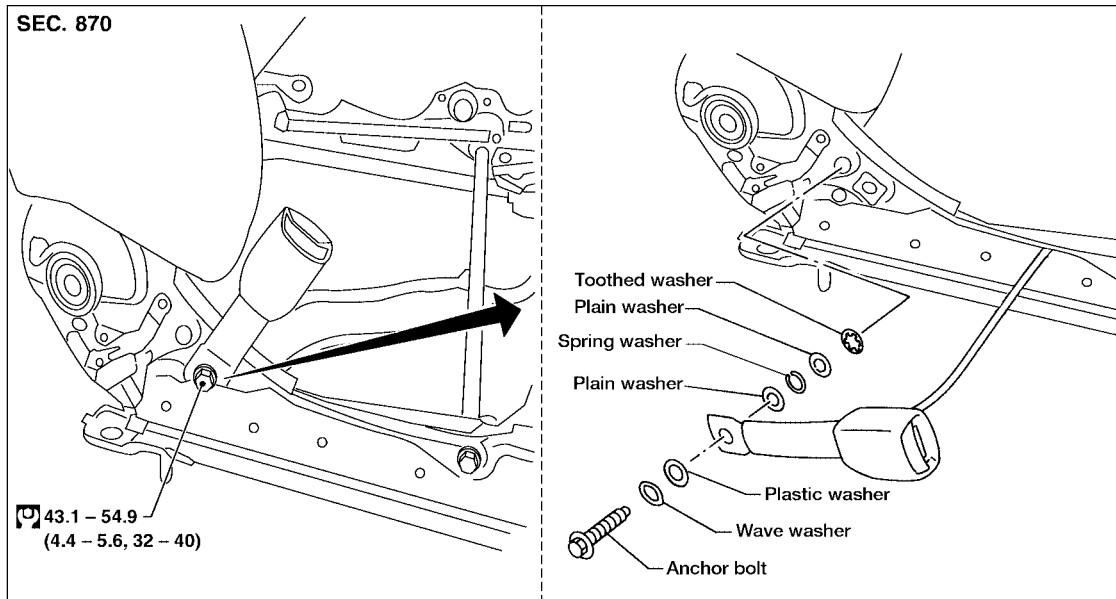
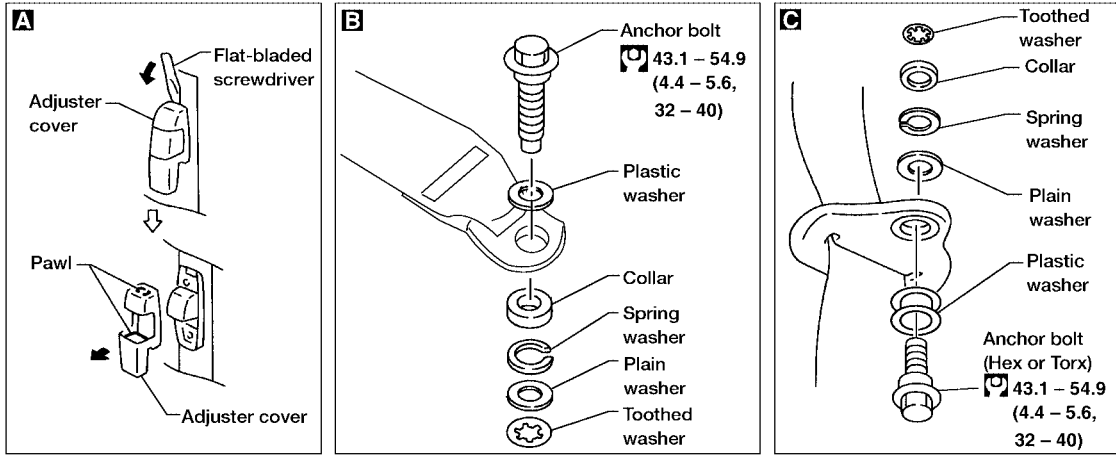

: N·m (kg·m, ft·lb)

WRS044

REAR SEAT BELT

PFP:88840

EHS000J9

REAR SEAT BELT

Removal and Installation

1. Remove rear seat. Refer to [SE-5, "REAR SEAT"](#) for details.
2. Remove outer and floor anchor bolt. **A B**
3. Remove rear side garnish. Refer to [EI-28, "SIDE AND FLOOR TRIM"](#) for details.
4. Remove rear parcel shelf finisher. Refer to [EI-28, "SIDE AND FLOOR TRIM"](#) for details.
5. Remove bolts securing rear seat belt retractor, then remove seat belt and seat belt retractor. **C D**

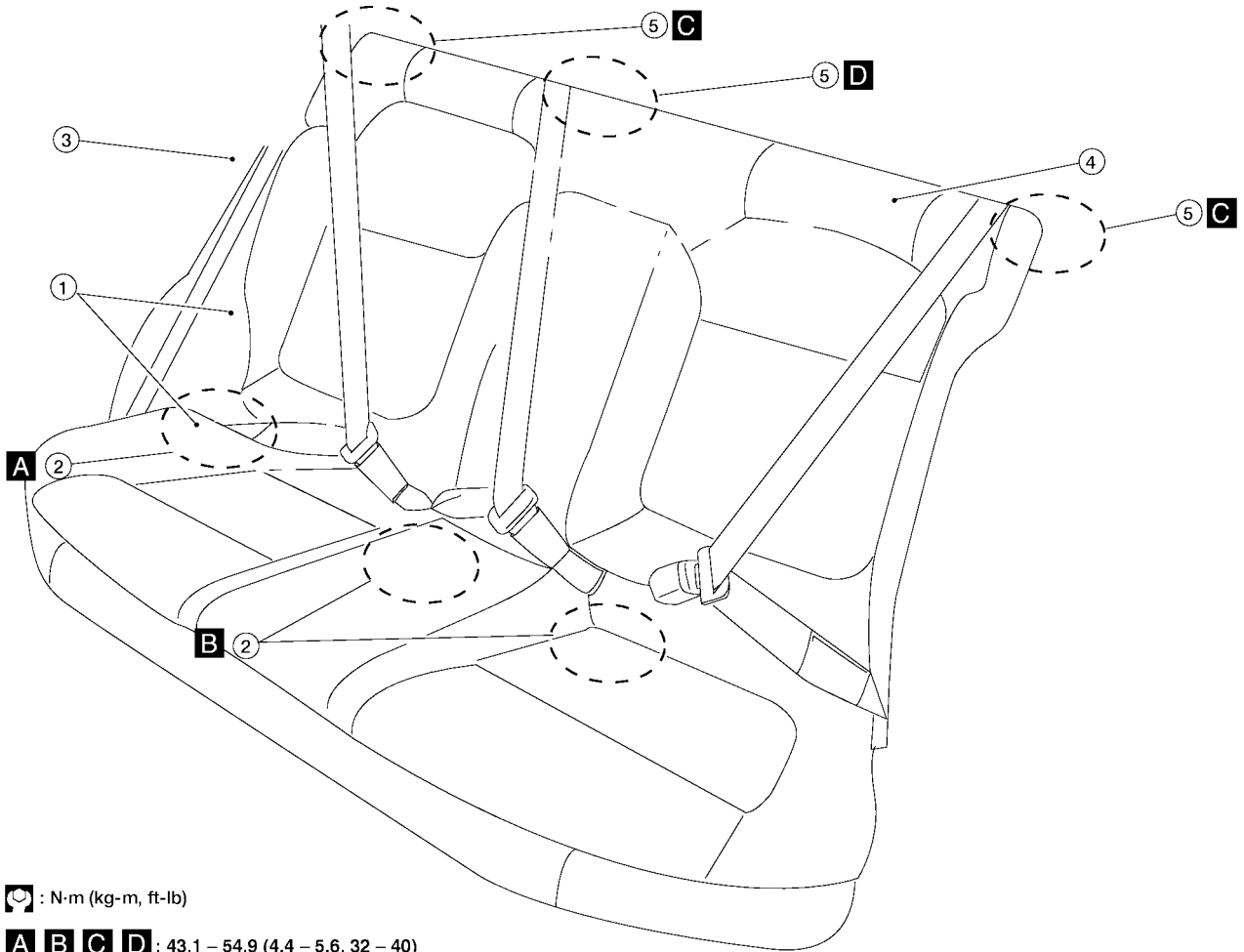

: N·m (kg·m, ft·lb)

A B C D : 43.1 – 54.9 (4.4 – 5.6, 32 – 40)

WRS147

A
B
C
D
E
F
G
SB
I
J
K
L
M

REAR SEAT BELT

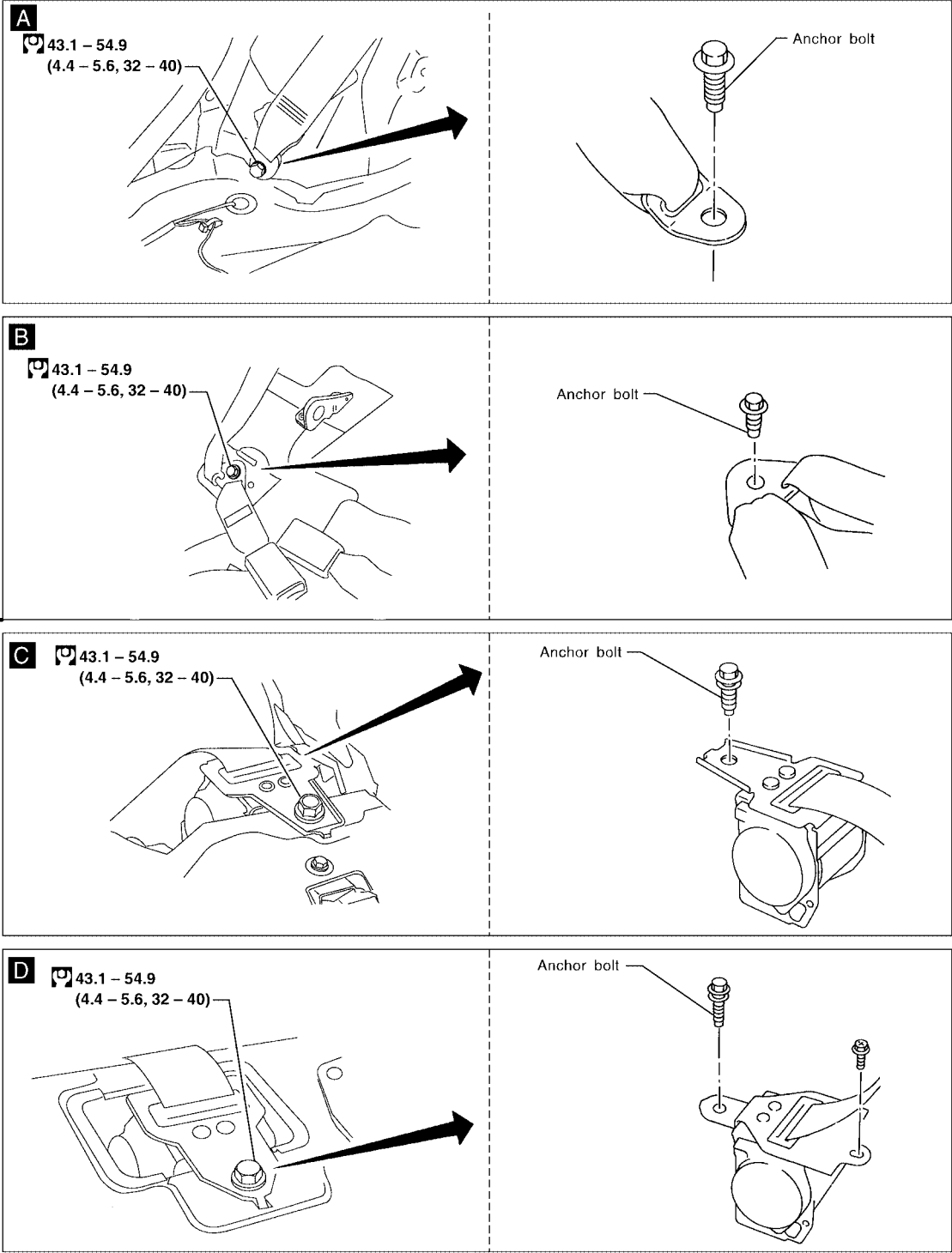

: N-m (kg-m, ft-lb)

BASIC INSPECTION

PF0:00013

EHS000JA

BASIC INSPECTION

Seat Belt Inspection AFTER A COLLISION

WARNING:

Inspect all seat belt assemblies including retractors and attaching hardware after any collision. NISSAN recommends that all seat belt assemblies in use during a collision be replaced unless the collision was minor and the belts show no damage and continue to operate properly. Failure to do so could result in serious personal injury in an accident. Seat belt assemblies not in use during a collision should also be replaced if either damage or improper operation is noted. Front seat belt pre-tensioner should be replaced even if the seat belts are not in use during a frontal collision in which the air bags are deployed.

Replace any seat belt assembly (including anchor bolts) if:

- The seat belt was in use at the time of a collision (except for minor collisions if the belts, retractors and buckles show no damage and continue to operate properly).
- The seat belt was damaged in an accident. (i.e. torn webbing, bent retractor or guide, etc.)
- The seat belt attaching point was damaged in an accident. Inspect the seat belt attaching area for damage or distortion and repair as necessary before installing a new seat belt assembly.
- Anchor bolts are deformed or worn out.
- The front seat belt pre-tensioner should be replaced even if the seat belts are not in use during the collision in which the air bags are deployed.

PRELIMINARY CHECKS

1. Check the seat belt warning lamp/chime for proper operation as follows:
 - a. Switch ignition ON. With driver seat belt unfastened, the seat belt warning lamp should illuminate. Also, the seat belt warning chime should sound for about seven seconds.
 - b. Fasten driver seat belt. The seat belt warning lamp should go out and the chime (if sounding) should stop.
2. If the "AIR BAG" warning lamp is blinking, conduct self-diagnosis using CONSULT-II, and "AIR BAG" warning lamp. Refer to [SRS-17, "SRS Operation Check"](#).
3. Check that the seat belt retractor, seat belt anchor and buckle bolts are securely attached.
4. Check the shoulder seat belt guide and shoulder belt height adjuster for front seats. Ensure guide swivels freely and that belt lays flat and does not bind in guide. Ensure height adjuster operates properly and holds securely.
5. Check retractor operation:
 - a. Fully extend the seat belt webbing and check for twists, tears or other damage.
 - b. Allow the seat belt to retract. Ensure that belt returns smoothly and completely into the retractor. If the seat belt does not return smoothly, wipe the inside of the loops with a clean paper cloth etc. because dirt built up in the loops of the upper anchors can cause the seat belts to retract slowly.
 - c. Fasten the seat belt. Pull firmly on belt and buckle to ensure belt remains latched. Unfasten seat belt. Ensure belt releases freely and buckle button returns to original position.
6. Repeat steps above as necessary to check the other seat belts.

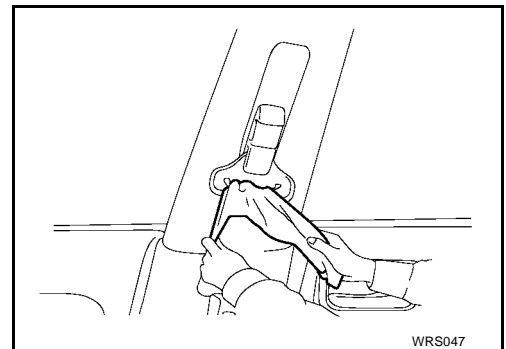

BASIC INSPECTION

SEAT BELT RETRACTOR ON-VEHICLE CHECK

Emergency Locking Retractors (ELR) and Automatic Locking Retractors (ALR)

NOTE:

All seat belt retractors are of the Emergency Locking Retractors (ELR) type. In an emergency (sudden stop) the retractor will lock and prevent the belt from extending any further. All 3-point type seat belt retractors except the driver's seat belt also have an Automatic Locking Retractors (ALR) mode. The ALR mode (also called child restraint mode) is used when installing child seats. The ALR mode is activated when the seat belt is fully extended. When the belt is then retracted partially, the ALR mode automatically locks the seat belt in a specific position so the belt cannot be extended any further. To cancel the ALR mode, allow the seat belt to fully wind back into the retractor.

Check the seat belt retractors using the following test(s) to determine if a retractor assembly is operating properly.

ELR Function Stationary Check

Grasp the shoulder belt and pull forward quickly. The retractor should lock and prevent the belt from extending further.

ALR Function Stationary Check

1. Pull out entire length of seat belt from retractor until a click is heard.
2. Retract the belt partially. A clicking noise should be heard as the belt retracts indicating that the retractor is in the Automatic Locking Retractors (ALR) mode.
3. Grasp the seat belt and try to pull out of the retractor. The belt must lock and not extend any further. If NG, replace the retractor assembly.
4. Allow the entire length of the belt to retract to cancel the automatic locking mode.

ELR Function Moving Check

WARNING:

Perform the following test in a safe, open area clear of other vehicles and obstructions (for example, a large, empty parking lot). Road surface must be paved and dry. DO NOT perform the following test on wet or gravel roads or on public streets and highways. This could result in an accident and serious personal injury. The driver and passenger must be prepared to brace themselves in the event the retractor does not lock.

1. Fasten driver's seat belt. Buckle a passenger into the seat for the belt that is to be tested.
2. Proceed to the designated safe area.
3. Drive the vehicle at approximately 16 km/h (10 MPH). Notify any passengers of a pending sudden stop and the driver and passenger must be prepared to brace themselves in the event the retractor does not lock, apply brakes firmly and make a very hard stop.

During stop, seat belts should lock and not be extended. If the seat belt retractor assembly does not lock, perform the retractor off-vehicle check.

BASIC INSPECTION

SEAT BELT RETRACTOR OFF-VEHICLE CHECK

1. Remove the seat belt retractor assembly.
2. Slowly pull out belt while tilting the retractor assembly forward from the mounted position without twisting the retractor assembly as shown in the illustration.

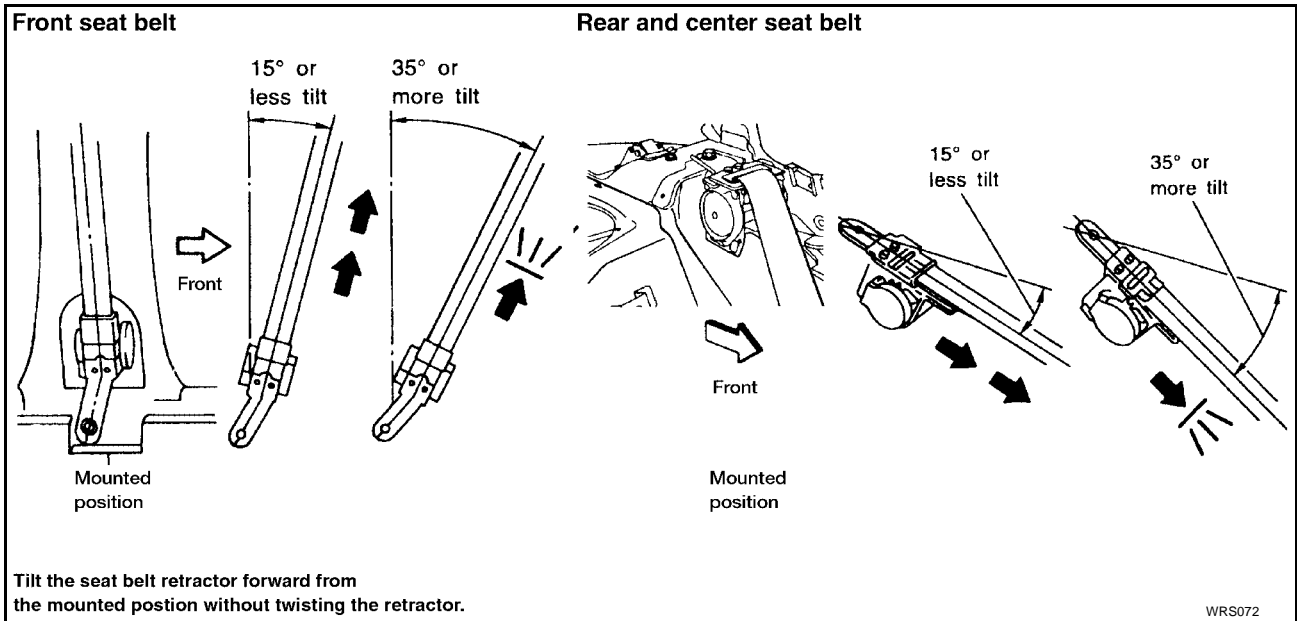

15 degrees or less tilt : Belt can be pulled out.

35 degrees or more tilt : Belt locks and cannot be pulled out.

If NG, replace the retractor assembly.

A
B
C
D
E
F
G
I
J
K
L
M

SB

TOP TETHER STRAP CHILD RESTRAINT

PFP:00025

TOP TETHER STRAP CHILD RESTRAINT

Removal and Installation

EHS000JB

CAUTION:

Replace anchor bolts if they are deformed or worn out.

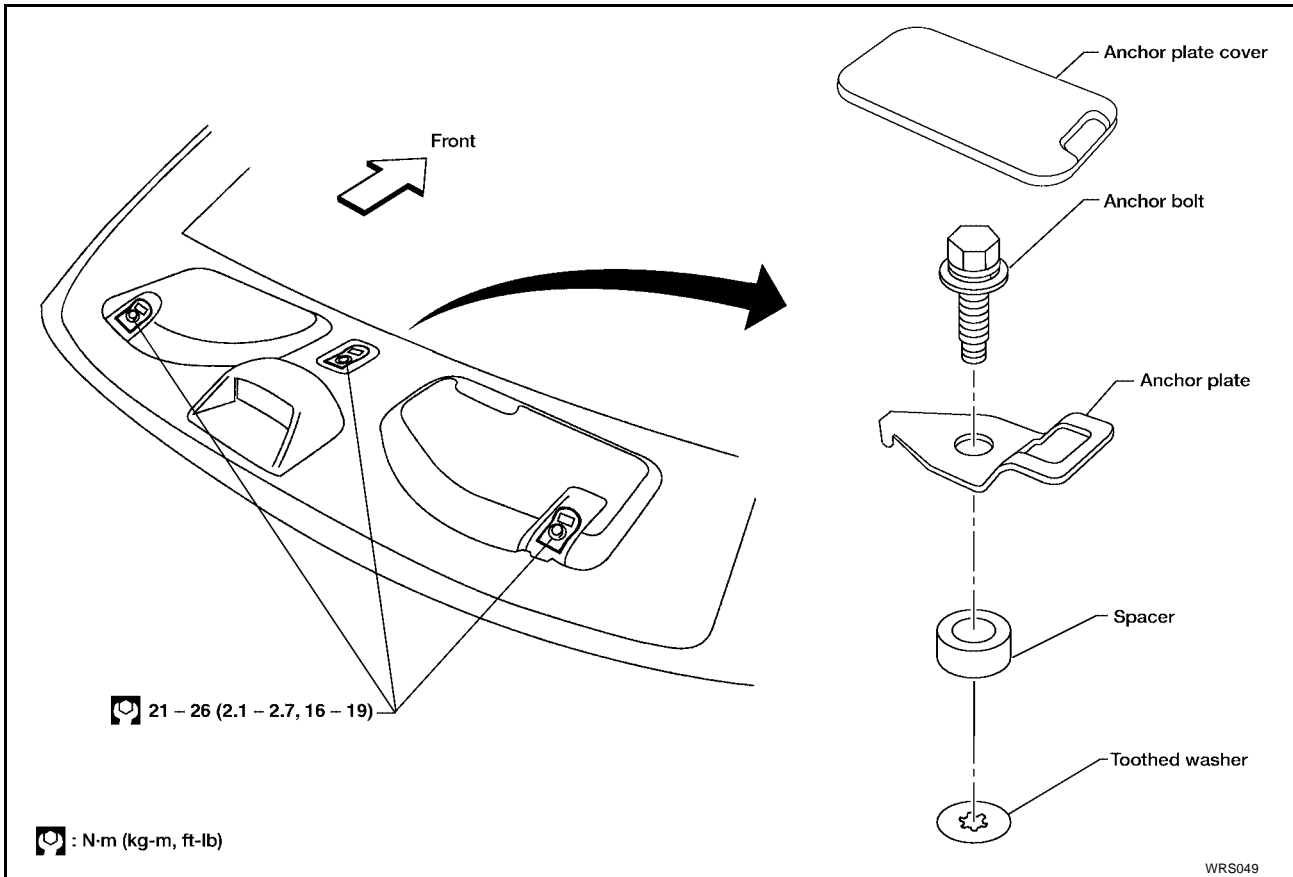

1. Remove anchor plate cover. Refer to [EI-28, "SIDE AND FLOOR TRIM"](#) for details.
2. Remove anchor plate.

NOTE:

- To install, reverse the removal procedure sequence.

LATCH (LOWER ANCHORS AND TETHER FOR CHILDREN) SYSTEM

LATCH (LOWER ANCHORS AND TETHER FOR CHILDREN) SYSTEM

PFP:88840

Removal and Installation

EHS000JC

CAUTION:

Replace anchor bolts if they are deformed or worn out.

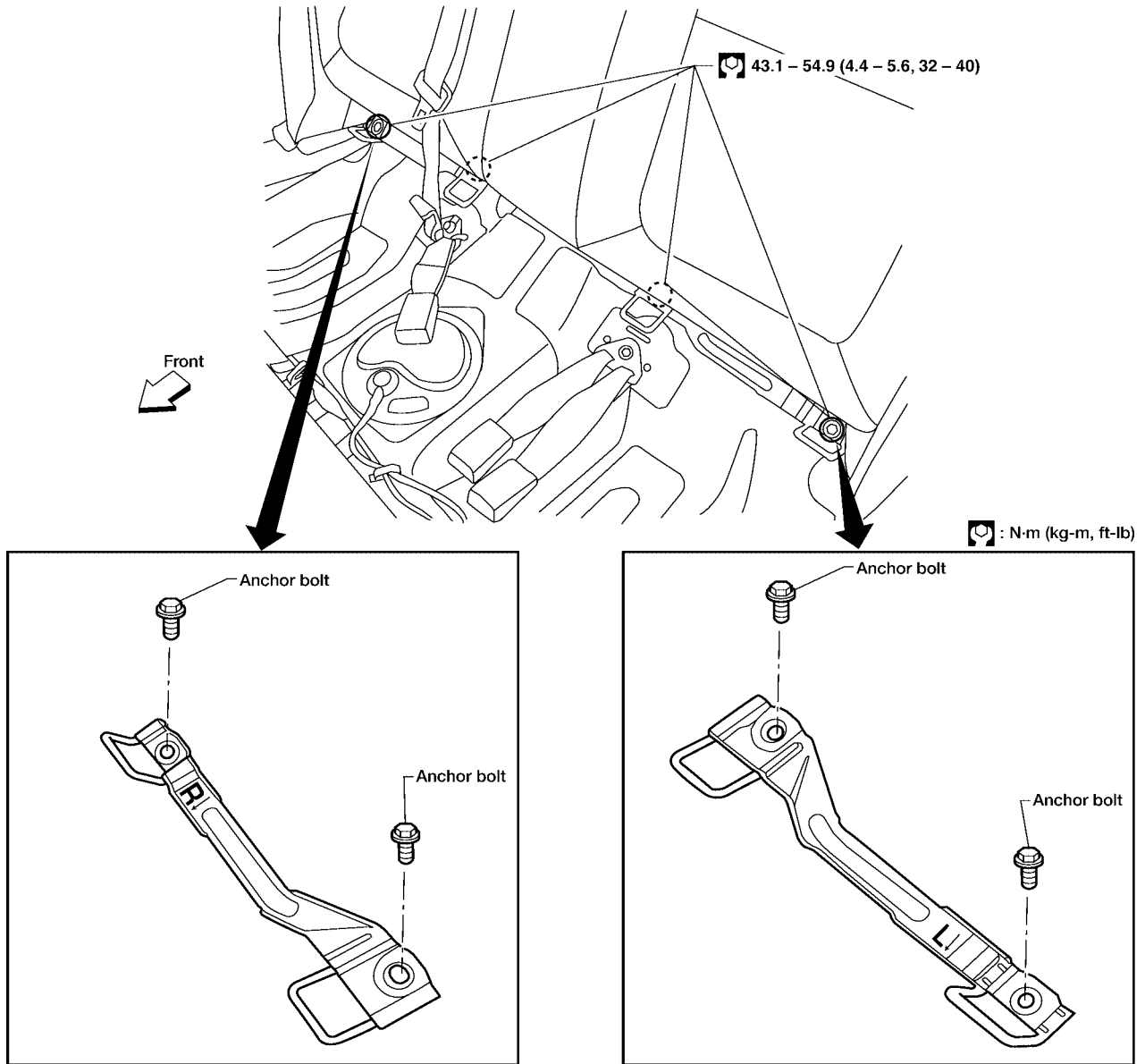

1. Remove rear seat cushion. Refer to [SE-5, "REAR SEAT"](#) for details.
2. Remove LH and RH LATCH System anchors.

NOTE:

LH and RH LATCH System anchors are different.
Install with arrow facing forward.

A
B
C
D
E
F
G
SB
I
J
K
L
M

LATCH (LOWER ANCHORS AND TETHER FOR CHILDREN) SYSTEM
