

SECTION **RAX**  
REAR AXLE

A  
B  
C

RAX

CONTENTS

E

<b>PRECAUTIONS</b> .....	2	Rear Axle Parts .....	5	F
Precautions .....	2	Rear Wheel Bearing .....	5	
<b>PREPARATION</b> .....	3	<b>WHEEL HUB</b> .....	6	G
Special Service Tools .....	3	Components .....	6	
Commercial Service Tools .....	3	Removal .....	6	
<b>NOISE, VIBRATION, AND HARSHNESS (NVH)</b>		Installation .....	7	H
<b>TROUBLESHOOTING</b> .....	4	<b>SERVICE DATA AND SPECIFICATIONS (SDS)</b> .....	9	
NVH Troubleshooting Chart .....	4	Wheel Bearing (Rear) .....	9	
<b>ON-VEHICLE SERVICE</b> .....	5			

I

J

K

L

M

# PRECAUTIONS

## PRECAUTIONS

PFP:00001

### Precautions

EDS000QR

- When installing each rubber part, final tightening must be carried out under unladen condition\* with tires on ground.  
\*: Fuel, radiator coolant and engine oil full. Spare tire, jack, hand tools and mats in designated positions.
- Use flare nut wrench when removing or installing brake tubes.
- After installing removed suspension parts, check wheel alignment.
- Do not jack up at the trailing arm and lateral link.
- Always torque brake lines when installing.

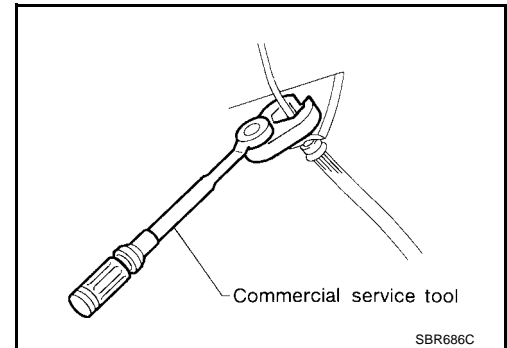

# PREPARATION

## PREPARATION

PFP:00002

### Special Service Tools

EDS0000S

The actual shapes of the Kent-Moore tools may differ from those of the special service tools illustrated here.

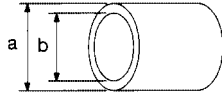
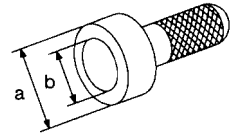
Tool number (Kent-Moore No.) Tool name	Description
KV40104710 ( — ) Drift <div style="text-align: center;">  <p>NT474</p> </div>	Install sensor rotor <b>a: 76.3 mm (3.004 in) dia.</b> <b>b: 67.9 mm (2.673 in) dia.</b>
ST30720000 ( — ) Drift <div style="text-align: center;">  <p>NT115</p> </div>	Install sensor rotor <b>a: 77 mm (3.03 in) dia.</b> <b>b: 55.5 mm (2.185 in) dia.</b>

A  
B  
C  
**RAX**  
E  
F  
G  
H  
I  
J  
K  
L  
M

### Commercial Service Tools

EDS0000T

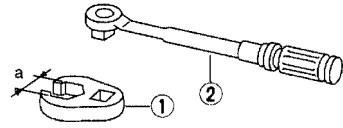
Tool name	Description
1. Flare nut crowfoot 2. Torque wrench <div style="text-align: center;">  <p>NT360</p> </div>	Removing and installing brake piping <b>a: 10 mm (0.39 in)</b>

# NOISE, VIBRATION, AND HARSHNESS (NVH) TROUBLESHOOTING

## NOISE, VIBRATION, AND HARSHNESS (NVH) TROUBLESHOOTING

PF0:00003

### NVH Troubleshooting Chart

EDS0000U

Use the chart below to help you find the cause of the symptom. If necessary, repair or replace these parts.

Reference page		<a href="#">RSU-8, "Removal and Installation"</a>	<a href="#">RSU-8, "Removal and Installation"</a>	<a href="#">RAX-5, "Rear Wheel Bearing"</a>	<a href="#">WT-2, "NVH Troubleshooting Chart"</a>	<a href="#">WT-2, "NVH Troubleshooting Chart"</a>
Possible cause and SUSPECTED PARTS		Improper installation, looseness	Parts interference	Wheel bearing damage	TIRES	ROAD WHEEL
Symptom	Noise	x	x		x	x
	Shake	x	x		x	x
	Vibration	x	x		x	
	Shimmy	x	x		x	x
	Shudder	x			x	x
	Poor quality ride or handling	x	x	x	x	x

x: Applicable

## ON-VEHICLE SERVICE

PFP:00000

### Rear Axle Parts

EDS000QV

- Check axle and suspension parts for excessive play, wear or damage.
- Shake each rear wheel to check for excessive play.
- Retighten all axle and suspension nuts and bolts to the specified torque.

**Tightening torque** : Refer to [RSU-5, "Components"](#) .

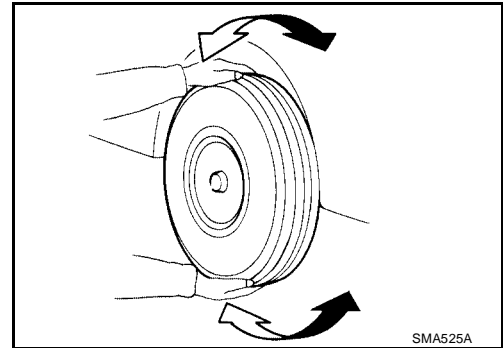

### Rear Wheel Bearing

EDS000QW

- Check axial end play.
  - Axial end play** : 0.05 mm (0.0020 in) or less
- Check that wheel hub bearings operate smoothly.
- Check tightening torque of wheel bearing lock nut.
  - Wheel bearing lock nut** : 187 - 255 N·m (19 - 26 kg·m, 138 - 188 ft·lb)
- If out of specification or if wheel bearing does not turn smoothly, replace wheel hub assembly. Refer to [RAX-6, "WHEEL HUB"](#) .

A  
B  
C  
RAX  
E  
F  
G  
H  
I  
J  
K  
L  
M

# WHEEL HUB

PF:43200

EDS000X

## WHEEL HUB

### Components

SEC. 430

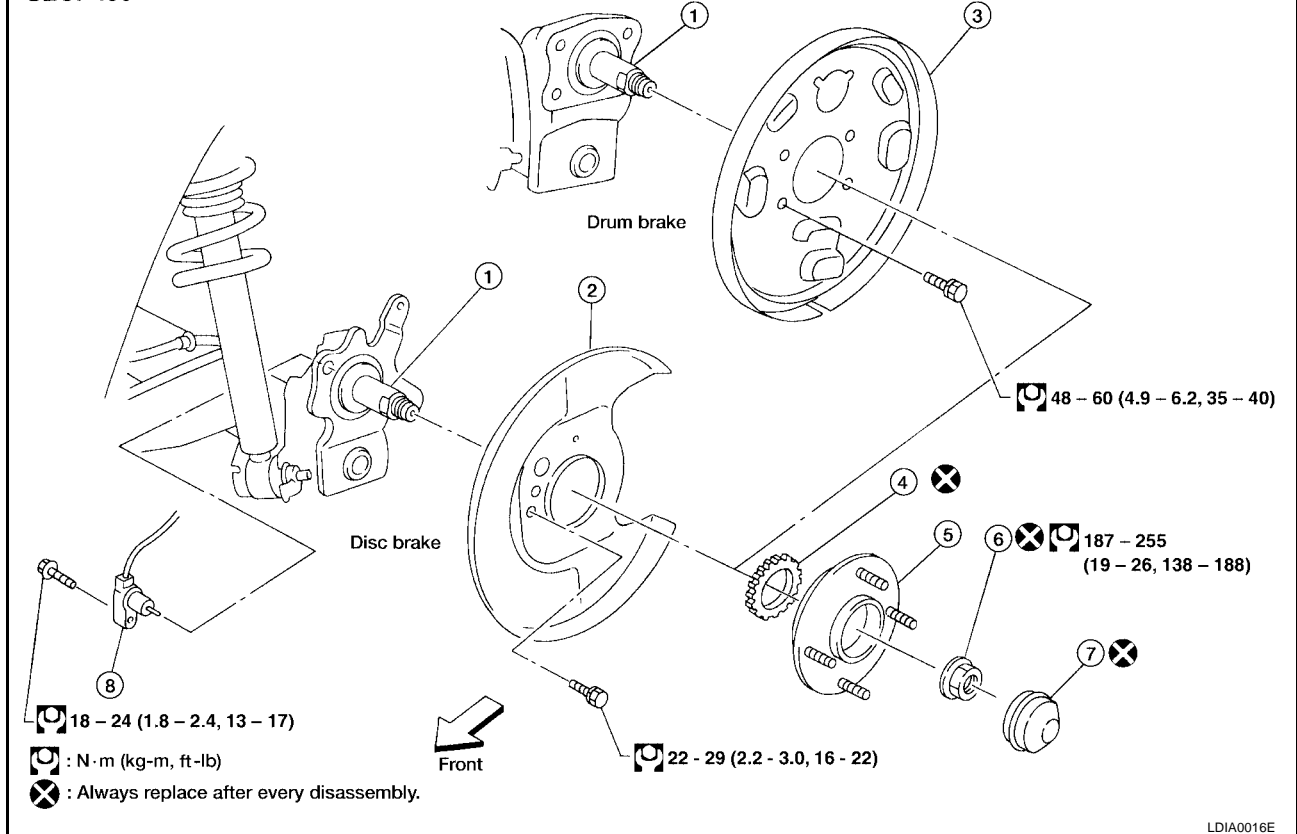

- |                               |                               |                           |
|-------------------------------|-------------------------------|---------------------------|
| 1. Spindle                    | 2. Baffle plate               | 3. Back plate             |
| 4. Sensor rotor (if equipped) | 5. Wheel hub                  | 6. Wheel bearing lock nut |
| 7. Hub cap                    | 8. Wheel sensor (if equipped) |                           |

## Removal

EDS000Y

### CAUTION:

- Before removing the rear wheel hub assembly, disconnect the wheel sensor from the assembly. Then move it away from the hub assembly. Failure to do so may result in damage to the sensor wires and the wheel sensor becoming inoperative.
- Wheel hub bearing does not require maintenance. If any of the following symptoms are noted, replace wheel hub bearing assembly.
  - Growling noise is emitted from wheel hub bearing during operation.
  - Wheel hub bearing drags or turns roughly. This occurs when turning hub by hand after bearing lock nut is tightened to specified torque.

1. Remove brake caliper assembly.
2. Remove wheel bearing lock nut.
3. Remove brake rotor.
4. Remove wheel hub bearing from spindle.

### CAUTION:

- Brake hose does not need to be disconnected from brake caliper.
- Suspend caliper assembly with wire so as not to stretch brake hose.
- Be careful not to depress brake pedal, or piston will pop out.
- Make sure brake hose is not twisted.

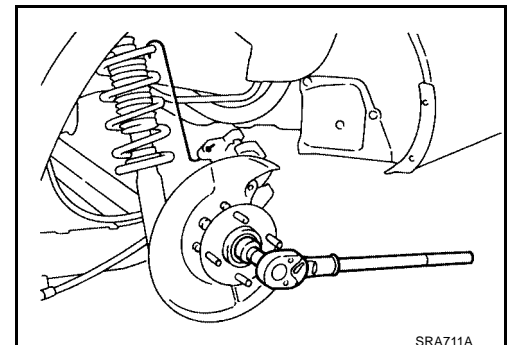

# WHEEL HUB

- Remove the sensor rotor, if equipped, using suitable puller, drift and bearing replacer.

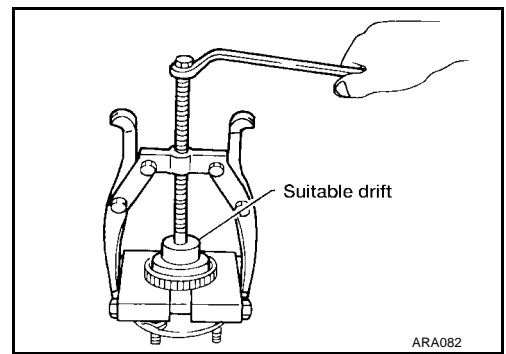

## Installation

Installation is in the reverse order of removal.

- With vehicles equipped with ABS, press-fit sensor rotor into wheel hub bearing using a drift.

### Tool number

A: ST30720000

B: KV40104710

### CAUTION:

Do not reuse sensor rotor. When installing, replace it with a new one.

- Press-fit sensor rotor as far as the location shown in figure.
- Install wheel hub bearing.

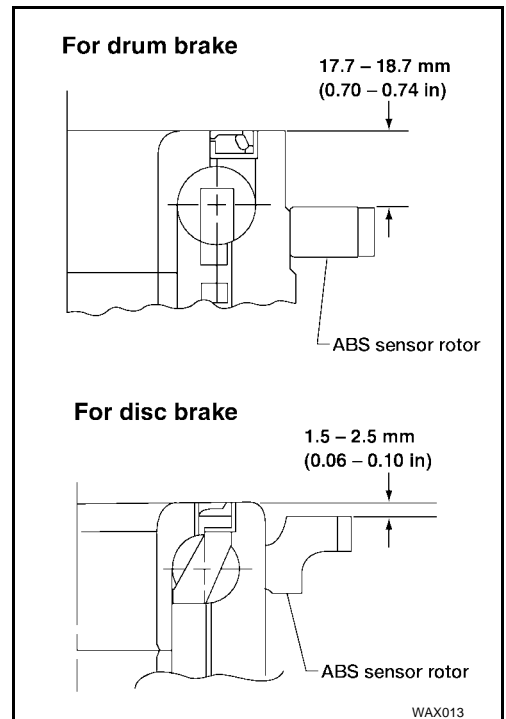
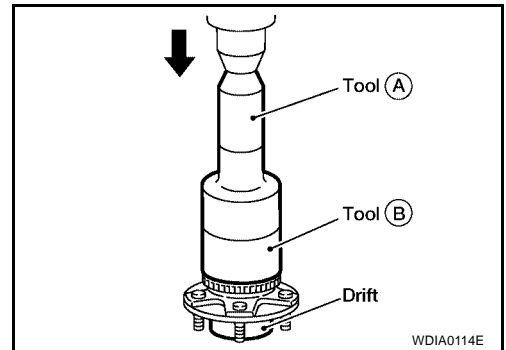

A  
B  
C  
RAX

E  
F  
G  
H  
I  
J  
K  
L  
M

## WHEEL HUB

- Tighten wheel bearing lock nut.  
Before tightening, apply oil to threaded portion of rear spindle.

**CAUTION:**

Do not reuse wheel bearing lock nut. When installing, replace it with a new one.

Wheel bearing lock nut : 187 - 255 N·m (19 - 26 kg·m,  
138 - 188 ft·lb)

- Check that wheel bearings operate smoothly.
- Check wheel hub bearing axial end play.

Axial end play : 0.05 mm (0.0020 in) or less

- Clinch two places of lock nut.

- Install hub cap using a suitable tool.

**CAUTION:**

Do not reuse hub cap. When installing, replace it with a new one.

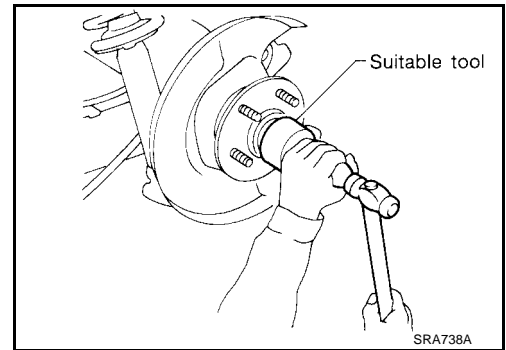
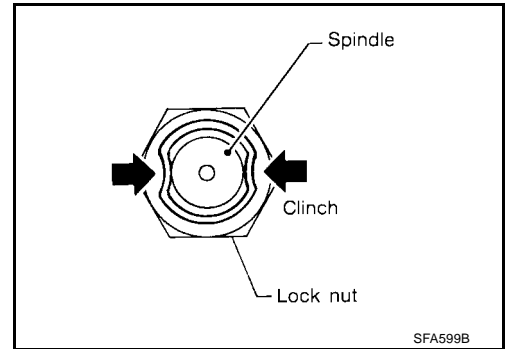
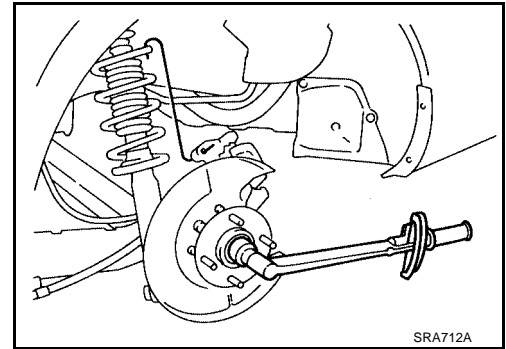



# SERVICE DATA AND SPECIFICATIONS (SDS)

## SERVICE DATA AND SPECIFICATIONS (SDS)

PFP:00030

### Wheel Bearing (Rear)

EDS000R0

Unit: mm (in)

Rear wheel bearing axial end play limit	0.05 (0.0020) or less
---	-----------------------

A

B

C

**RAX**

E

F

G

H

I

J

K

L

M

# SERVICE DATA AND SPECIFICATIONS (SDS)

---