

SECTION **BR**
BRAKE SYSTEM

A
B
C
D
E

CONTENTS

<p>PRECAUTIONS 3</p> <p style="padding-left: 20px;">Precautions for Supplemental Restraint System (SRS) "AIR BAG" and "SEAT BELT PRE-TENSIONER" 3</p> <p style="padding-left: 20px;">Precautions for Brake System 3</p> <p style="padding-left: 20px;">Wiring Diagrams and Trouble Diagnosis 3</p> <p>PREPARATION 4</p> <p style="padding-left: 20px;">Special Service Tool 4</p> <p style="padding-left: 20px;">Commercial Service Tools 4</p> <p>NOISE, VIBRATION, AND HARSHNESS (NVH)</p> <p>TROUBLESHOOTING 5</p> <p style="padding-left: 20px;">NVH Troubleshooting Chart 5</p> <p>ON-VEHICLE SERVICE 6</p> <p style="padding-left: 20px;">Checking Brake Fluid Level 6</p> <p style="padding-left: 20px;">Checking Brake Line 6</p> <p style="padding-left: 20px;">Changing Brake Fluid 6</p> <p style="padding-left: 20px;">Bleeding Brake System 7</p> <p style="padding-left: 20px;">Brake Burnishing Procedure 7</p> <p>BRAKE HYDRAULIC LINE 8</p> <p style="padding-left: 20px;">Hydraulic Circuit 8</p> <p style="padding-left: 20px;">Removal 8</p> <p style="padding-left: 20px;">Inspection 9</p> <p style="padding-left: 20px;">Installation 9</p> <p>DUAL PROPORTIONING VALVE 10</p> <p style="padding-left: 20px;">Inspection 10</p> <p>BRAKE PEDAL AND BRACKET 11</p> <p style="padding-left: 20px;">Removal and Installation 11</p> <p style="padding-left: 20px;">Inspection 11</p> <p style="padding-left: 20px;">Adjustment 12</p> <p style="padding-left: 40px;">BRAKE PEDAL HEIGHT 12</p> <p style="padding-left: 40px;">STOP LAMP SWITCH AND ASCD CANCEL SWITCH CLEARANCE 12</p> <p>MASTER CYLINDER 13</p> <p style="padding-left: 20px;">Removal 13</p> <p style="padding-left: 20px;">Disassembly 14</p> <p style="padding-left: 20px;">Inspection 14</p> <p style="padding-left: 20px;">Assembly 14</p> <p style="padding-left: 20px;">Installation 15</p>	<p>BRAKE BOOSTER 16</p> <p style="padding-left: 20px;">On-vehicle Service 16</p> <p style="padding-left: 40px;">OPERATING CHECK 16</p> <p style="padding-left: 40px;">AIRTIGHT CHECK 16</p> <p style="padding-left: 20px;">Removal 16</p> <p style="padding-left: 20px;">Inspection 17</p> <p style="padding-left: 40px;">OUTPUT ROD LENGTH CHECK 17</p> <p style="padding-left: 20px;">Installation 17</p> <p>VACUUM HOSE 18</p> <p style="padding-left: 20px;">Removal and Installation 18</p> <p style="padding-left: 20px;">Inspection 18</p> <p style="padding-left: 40px;">HOSES AND CONNECTORS 18</p> <p style="padding-left: 40px;">CHECK VALVE 18</p> <p>FRONT DISC BRAKE (CL25VA/CL25VB TYPE) 19</p> <p style="padding-left: 20px;">On-board Inspection 19</p> <p style="padding-left: 40px;">PAD WEAR INSPECTION 19</p> <p style="padding-left: 20px;">Component 19</p> <p style="padding-left: 20px;">Pad Replacement 19</p> <p style="padding-left: 20px;">Removal and Installation of Caliper Assembly and Disc Rotor 20</p> <p style="padding-left: 40px;">REMOVAL 20</p> <p style="padding-left: 40px;">INSTALLATION 21</p> <p style="padding-left: 20px;">Disassembly and Assembly of Caliper Assembly... 21</p> <p style="padding-left: 40px;">DISASSEMBLY 21</p> <p style="padding-left: 40px;">CALIPER INSPECTION 21</p> <p style="padding-left: 40px;">DISC ROTOR INSPECTION 22</p> <p style="padding-left: 40px;">ASSEMBLY 22</p> <p>FRONT DISC BRAKE (OPB27VA TYPE) 23</p> <p style="padding-left: 20px;">On-board Inspection 23</p> <p style="padding-left: 40px;">PAD WEAR INSPECTION 23</p> <p style="padding-left: 20px;">Component 23</p> <p style="padding-left: 20px;">Pad Replacement 24</p> <p style="padding-left: 40px;">REMOVAL 24</p> <p style="padding-left: 40px;">HOW TO APPLY GREASE TO THE BRAKE PAD.. 25</p> <p style="padding-left: 40px;">INSTALLATION 25</p> <p style="padding-left: 20px;">Removal and Installation of Caliper Assembly and Disc Rotor 26</p> <p style="padding-left: 40px;">REMOVAL 26</p>
--	--

BR
G
H
I
J
K
L
M

INSTALLATION	26	REAR DRUM BRAKE	38
Disassembly and Assembly of Caliper Assembly...	26	Components	38
DISASSEMBLY	26	Removal	38
CALIPER INSPECTION	27	Inspection	40
DISC ROTOR INSPECTION	27	WHEEL CYLINDER	40
ASSEMBLY	28	WHEEL CYLINDER OVERHAUL	40
REAR DISC BRAKE	29	DRUM	40
On-board Inspection	29	LINING	40
PAD WEAR INSPECTION	29	Installation	41
Component	29	SERVICE DATA AND SPECIFICATIONS (SDS)	42
Pad Replacement	30	General Specifications	42
Removal and Installation of Caliper Assembly and		Brake Pedal	42
Disc Rotor	31	Front Disc Brake	42
REMOVAL	31	Rear Disc Brake	43
INSTALLATION	31	Drum Brake	43
Disassembly and Assembly of Caliper Assembly...	32		
DISASSEMBLY	32		
CALIPER INSPECTION	33		
DISC ROTOR INSPECTION	34		
ASSEMBLY	34		

PRECAUTIONS

PRECAUTIONS

PFP:00001

Precautions for Supplemental Restraint System (SRS) "AIR BAG" and "SEAT BELT PRE-TENSIONER"

EFS0022M

The Supplemental Restraint System such as "AIR BAG" and "SEAT BELT PRE-TENSIONER", used along with a front seat belt, helps to reduce the risk or severity of injury to the driver and front passenger for certain types of collision. Information necessary to service the system safely is included in the SRS and SB section of this Service Manual.

WARNING:

- To avoid rendering the SRS inoperative, which could increase the risk of personal injury or death in the event of a collision which would result in air bag inflation, all maintenance must be performed by an authorized NISSAN/INFINITI dealer.
- Improper maintenance, including incorrect removal and installation of the SRS, can lead to personal injury caused by unintentional activation of the system. For removal of Spiral Cable and Air Bag Module, see the SRS section.
- Do not use electrical test equipment on any circuit related to the SRS unless instructed to in this Service Manual. SRS wiring harnesses can be identified by yellow and/or orange harnesses or harness connectors.

Precautions for Brake System

EFS0022N

- Recommended fluid is brake fluid "DOT 3".
- Never reuse drained brake fluid.
- Be careful not to splash brake fluid on painted areas.
- To clean or wash all parts of master cylinder, disc brake caliper and wheel cylinder, use clean brake fluid.
- Never use mineral oils such as gasoline or kerosene. They will ruin rubber parts of the hydraulic system.
- Use flare nut wrench when removing and installing brake tube.
- Always torque brake lines when installing.
- Burnish the brake contact surfaces after refinishing or replacing drums or rotors, after replacing pads or linings, or if a soft pedal occurs at very low mileage. Refer to [BR-7, "Brake Burnishing Procedure"](#).

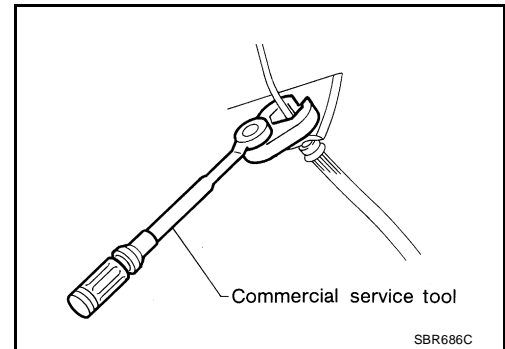

WARNING:

- Clean brake pads and shoes with a waste cloth, then wipe with a dust collector.

Wiring Diagrams and Trouble Diagnosis

EFS0022O

When you read wiring diagrams, refer to the following:

- [GI-14, "How to Read Wiring Diagrams"](#)
- [PG-3, "POWER SUPPLY ROUTING"](#)

When you perform trouble diagnosis, refer to the following:

- [GI-10, "HOW TO FOLLOW TEST GROUPS IN TROUBLE DIAGNOSES"](#)
- [GI-26, "How to Perform Efficient Diagnosis for an Electrical Incident"](#)

PREPARATION

PREPARATION

PFP:00002

Special Service Tool

EFS004YO

The actual shapes of Kent-Moore tools may differ from those of special service tools illustrated here.

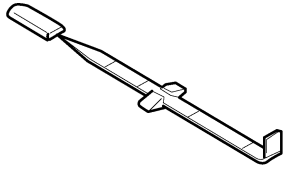
Tool number (Kent-Moore No.) Tool name	Description
<p>— (J-46532) Brake and clutch pedal height measurement tool</p>  <p style="text-align: right; margin-right: 50px;">LFIA0227E</p>	<p>Measuring brake pedal height</p>

Commercial Service Tools

EFS0022P

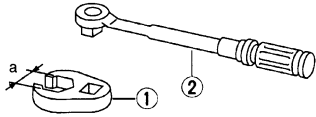
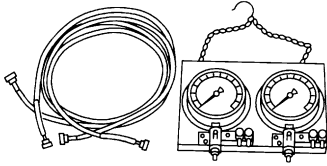
Tool name	Description
<p>1 Flare nut crowfoot 2 Torque wrench</p>  <p style="text-align: right; margin-right: 50px;">S-NT360</p>	<p>Removing and installing brake piping a: 10 mm (0.39 in)</p>
<p>Brake fluid pressure gauge</p>  <p style="text-align: right; margin-right: 50px;">NT151</p>	<p>Measuring brake fluid pressure</p>

NOISE, VIBRATION, AND HARSHNESS (NVH) TROUBLESHOOTING

NOISE, VIBRATION, AND HARSHNESS (NVH) TROUBLESHOOTING

PF0:0003

NVH Troubleshooting Chart

EF50022Q

Use the chart below to help you find the cause of the symptom. If necessary, repair or replace these parts.

Reference page			Possible cause and SUSPECTED PARTS																	
Symptom	BRAKE	Noise	BR-19 , BR-24 , BR-30	BR-19 , BR-24 , BR-30	BR-19 , BR-23 , BR-29	BR-22 , BR-27 , BR-34	BR-22 , BR-27 , BR-34	BR-22 , BR-27 , BR-34	BR-22 , BR-27 , BR-34	BR-22 , BR-27 , BR-34	BR-7	BR-22 , BR-27 , BR-34	FAX-4 , " NVH Troubleshooting Chart "	FAX-4 , " NVH Troubleshooting Chart "	FSU-4 , " NVH Troubleshooting Chart "	FSU-4 , " NVH Troubleshooting Chart "	FSU-4 , " NVH Troubleshooting Chart "	PS-6 , " NVH Troubleshooting Chart "		
		Shake				X								X	X	X	X	X	X	
		Shimmy, Judder				X	X	X	X	X	X	X			X	X	X	X	X	X
Pads - damaged																				
Pads - uneven wear																				
Shims damaged																				
Rotor imbalance																				
Rotor damage																				
Rotor runout																				
Rotor deformation																				
Rotor deflection																				
Rotor rust																				
Rotor thickness variation																				
DRIVE SHAFT																				
AXLE																				
SUSPENSION																				
TIRES																				
ROAD WHEEL																				
STEERING																				

X: Applicable

A
B
C
D
E
F
G
H
I
J
K
L
M

BR

ON-VEHICLE SERVICE

PFP:00000

Checking Brake Fluid Level

EFS0022R

- Check fluid level in reservoir tank. It should be between the "Max" and "Min" lines on reservoir tank.
- If fluid level is extremely low, check brake system for leaks.
- Release parking brake lever and see if brake warning lamp goes off. If not, check brake system for leaks.

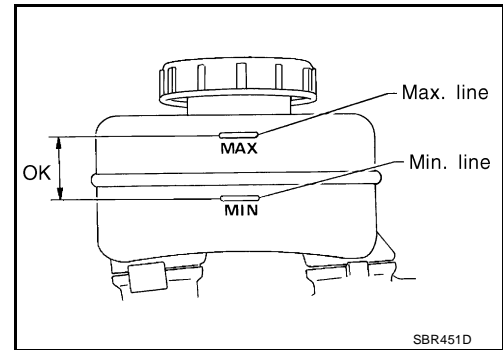

Checking Brake Line

EFS0022S

CAUTION:

If leakage occurs around joints, retighten or, if necessary, replace damaged parts.

1. Check brake lines (tubes and hoses) for cracks, deterioration or other damage. Replace any damaged parts.
2. Check for oil leakage by fully depressing brake pedal while engine is running.

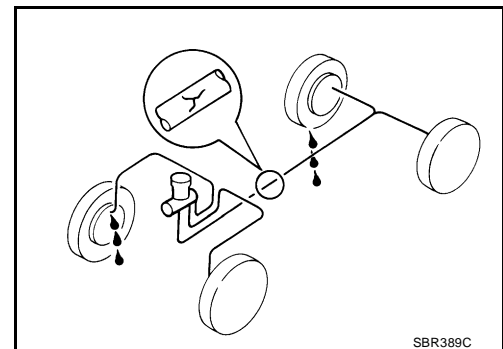

Changing Brake Fluid

EFS0022T

CAUTION:

- Refill with new brake fluid "DOT 3".
- Always keep fluid level higher than minimum line on reservoir tank.
- Never reuse drained brake fluid.
- Be careful not to splash brake fluid on painted areas; it may cause paint damage. If brake fluid is splashed on painted areas, wash it away with water immediately.

1. Clean inside of reservoir tank, and refill with new brake fluid.
2. Connect a vinyl tube to each air bleeder valve.
3. Drain brake fluid from each air bleeder valve by depressing brake pedal.
4. Refill brake fluid reservoir until brake fluid comes out of each air bleeder valve.
5. Use same procedure as in bleeding hydraulic system to refill brake fluid. Refer to [BR-7, "Bleeding Brake System"](#) .

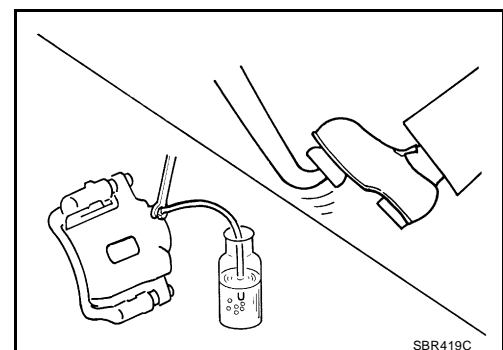

Bleeding Brake System

EFS0022V

CAUTION:

- Carefully monitor brake fluid level at master cylinder during bleeding operation.
- Fill reservoir with new brake fluid "DOT 3". Make sure it is full at all times while bleeding air out of system.
- Place a container under master cylinder to avoid spillage of brake fluid.
- For models with ABS, turn ignition switch OFF and disconnect ABS actuator and electric unit connectors or battery ground cable.
- Bleed air in the following order.
Right rear brake → Left front brake → Left rear brake → Right front brake

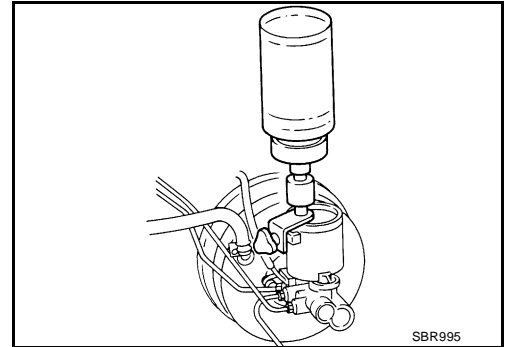

1. Connect a transparent vinyl tube to air bleeder valve.
2. Fully depress brake pedal several times.
3. With brake pedal depressed, open air bleeder valve to release air.
4. Close air bleeder valve.
5. Release brake pedal slowly.
6. Repeat steps 2 through 5 until clear brake fluid comes out of air bleeder valve.
7. Tighten air bleeder valve to specification.

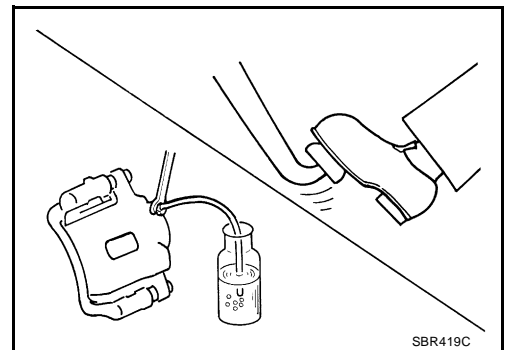

Air bleeder valve

Front and rear disc brake (CL25VA/CL25VB/CL9HC type) : 7 - 9 N·m (0.7 - 0.9 kg·m, 61 - 78 in·lb)

Front disc brake (OPB27VA type) : 12 - 15 N·m (1.3 - 1.5 kg·m, 9 - 11 ft·lb)

Rear drum brake : 6.9 - 8.8 N·m (0.71 - 0.89 kg·m, 61 - 77 in·lb)

Brake Burnishing Procedure

EFS0022U

Burnish the brake contact surfaces according to the following procedure after refinishing or replacing drums or rotors, after replacing pads or linings, or if a soft pedal occurs at very low mileage.

CAUTION:

Only perform this procedure under safe road and traffic conditions. Use extreme caution.

1. Drive the vehicle on a straight smooth road at 50 km/h (31 MPH).
2. Use medium brake pedal/foot effort to bring the vehicle to a complete stop from 50 km/h (31 MPH). Adjust brake pedal/foot pressure so that vehicle stopping time equals 3 to 5 seconds.
3. To cool the brake system, drive the vehicle at 50 km/h (31 MPH) for 1 minute without stopping.
4. Repeat steps 1 to 3, 10 times or more to complete the burnishing procedure.

BRAKE HYDRAULIC LINE

PFP:46210

BRAKE HYDRAULIC LINE

Hydraulic Circuit

EFS0022W

Without anti-lock brake system
(Models with dual proportioning valve built into master cylinder)
(built-in type)

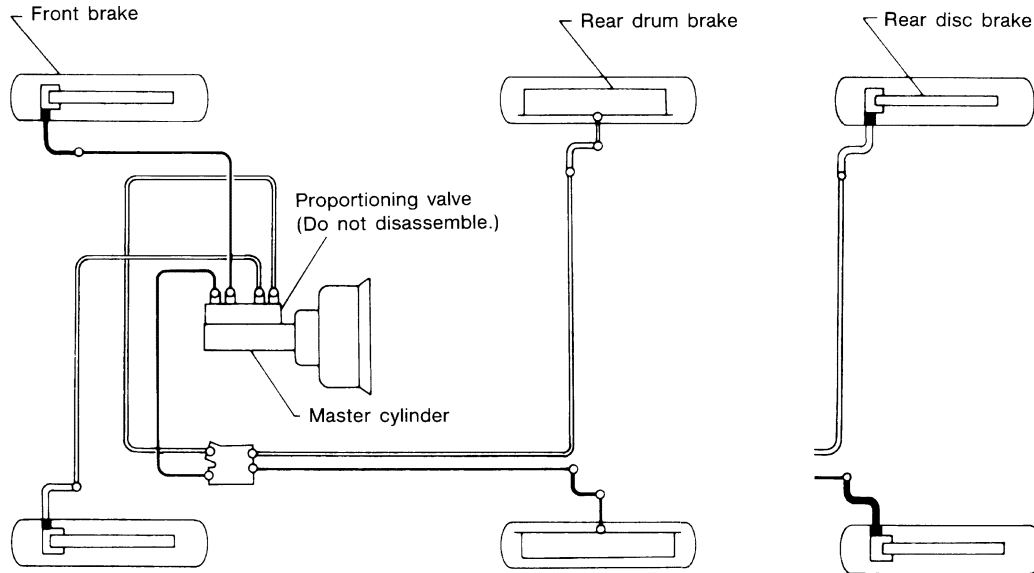

With anti-lock brake system

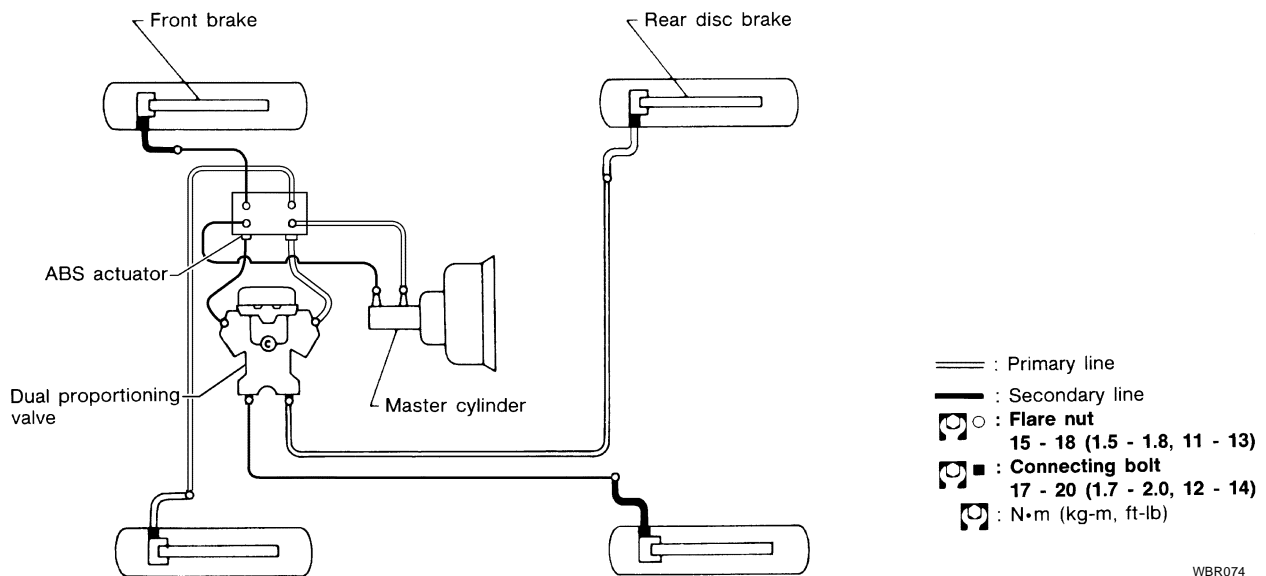

WBR074

Removal

EFS0022X

CAUTION:

- Be careful not to splash brake fluid on painted areas; it may cause paint damage. If brake fluid is splashed on painted areas, wash it away with water immediately.
- All hoses must be free from excessive bending, twisting and pulling.

BRAKE HYDRAULIC LINE

1. Connect vinyl tube to air bleeder valve.
2. Drain brake fluid from each air bleeder valve by depressing brake pedal.
3. Remove flare nut connecting brake tube and hose, then withdraw lock spring.
4. Cover openings to prevent entrance of dirt whenever disconnecting brake line.

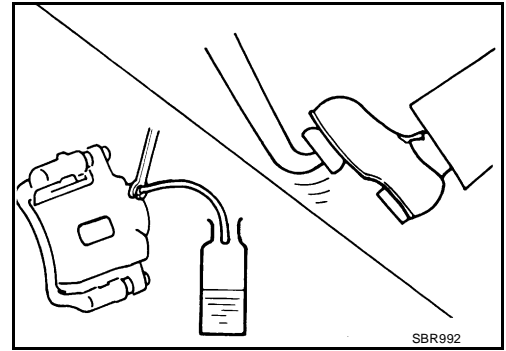

EFS0022Y

EFS0022Z

Inspection

Check brake lines (tubes and hoses) for cracks, deterioration or other damage. Replace any damaged parts.

Installation

1. Tighten all flare nuts and connecting bolts.

Specification

Flare nut : 15 - 18 N·m (1.5 - 1.8 kg·m, 11 - 13 ft·lb)

Connecting bolt : 17 - 20 N·m (1.7 - 2.0 kg·m, 12 - 14 ft·lb)

2. Refill until new brake fluid comes out of each air bleeder valve.

CAUTION:

- Refill with new brake fluid "DOT 3".
 - Never reuse drained brake fluid.
3. Bleed air from brake system. Refer to [BR-7, "Bleeding Brake System"](#).

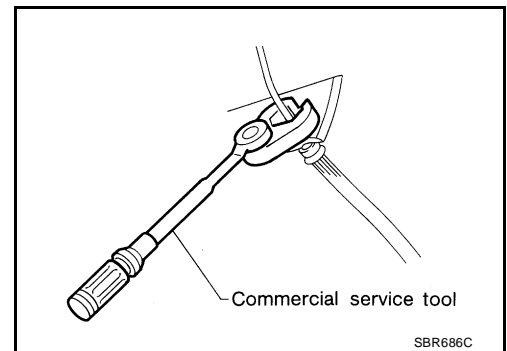

A
B
C
D
E
BR
G
H
I
J
K
L
M

DUAL PROPORTIONING VALVE

PFP:46400

EFS00230

DUAL PROPORTIONING VALVE

Inspection

CAUTION:

- Carefully monitor brake fluid level at master cylinder.
 - Use new brake fluid "DOT 3".
 - Be careful not to splash brake fluid on painted areas; it may cause paint damage. If brake fluid is splashed on paint areas, wash it away with water immediately.
1. Connect Tool to air bleeders of front and rear brakes on either LH and RH side.
 2. Bleed air from the Tool.
 3. Check fluid pressure by depressing brake pedal.

Unit: kPa (kg/cm² , psi)

Applied model	All QG18DE	QR25DE without ABS	QR25DE with ABS
Applied pressure (Front brake)	7,355 (75, 1,067)	6,374 (65, 924)	6,374 (65, 924)
Output pressure (Rear brake)	5,099 - 5,492 (52 - 56, 740 - 796)	3,775 - 4,168 (38 - 42, 548 - 604)	4,119 - 4,511 (42 - 46, 597 - 654)

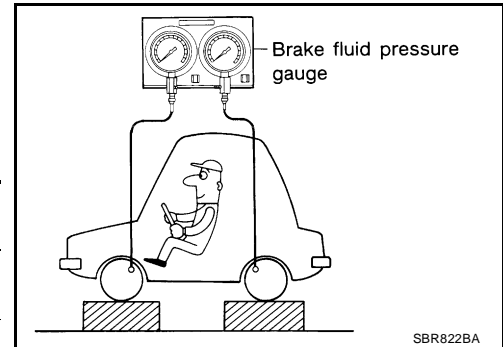

- If output pressure is out of specification, replace dual proportioning valve.
4. Bleed air after disconnecting the Tool. Refer to [BR-7, "Bleeding Brake System"](#) .

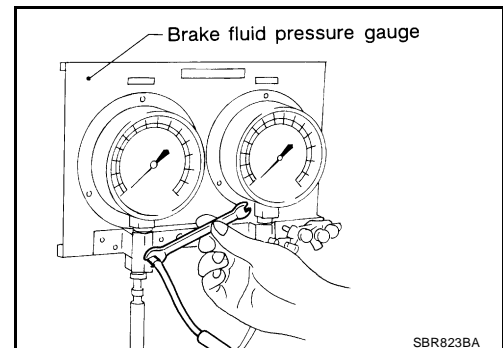

BRAKE PEDAL AND BRACKET

BRAKE PEDAL AND BRACKET

PFP:46501

Removal and Installation

EFS00231

SEC. 465•470

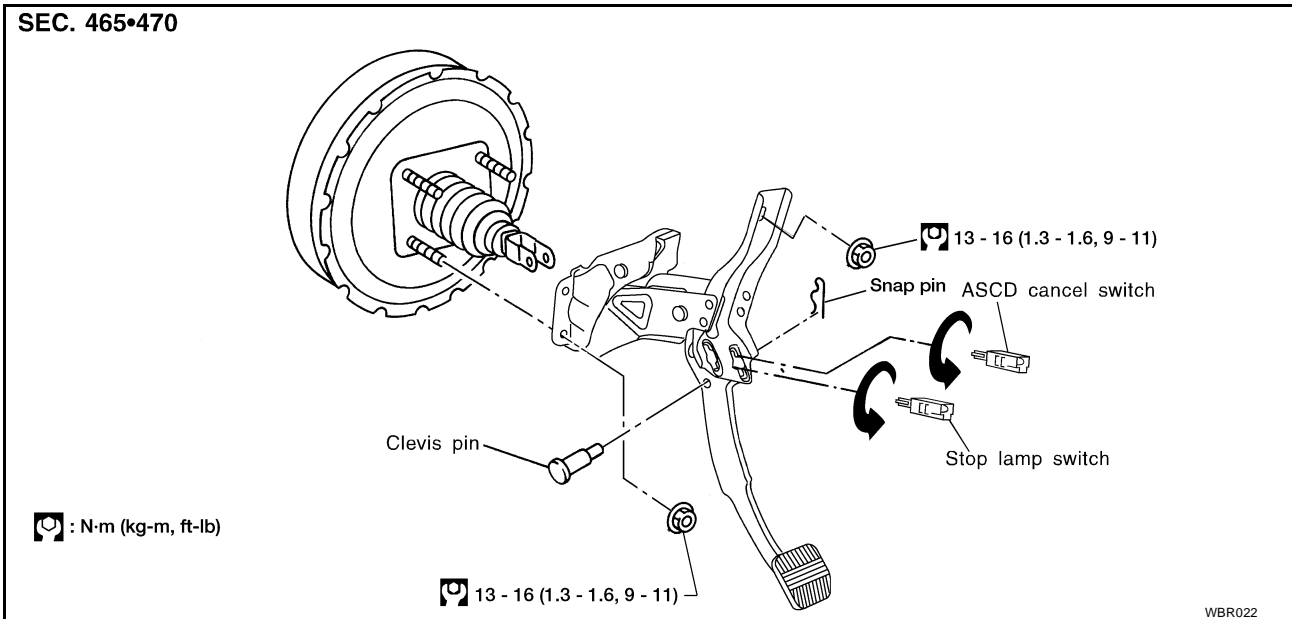

Inspection

EFS00232

- Check brake pedal for following items:
 - Brake pedal bend
 - Clevis pin deformation
 - Crack of any welded portion
 - Crack or deformation of clevis pin stopper

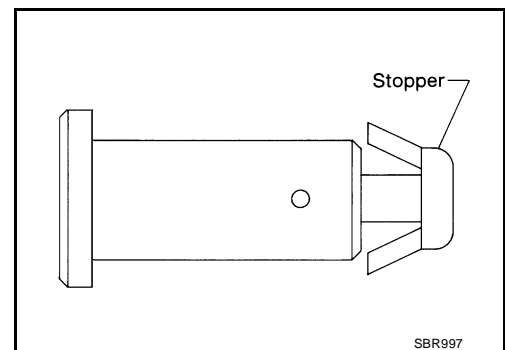

A
B
C
D
E
BR
G
H
I
J
K
L
M

BRAKE PEDAL AND BRACKET

EFS00233

Adjustment BRAKE PEDAL HEIGHT

- Check brake pedal free height using Tool, and adjust if necessary.

Tool number : - (J-46532)

H : Free height
Refer to [BR-42, "Brake Pedal"](#) .

D : Depressed height
90 mm (3.54 in)
Under force of 490 N (50 kg, 110 lb)
with engine running

A : Pedal free play at pedal pad
1.0 - 3.0 mm (0.039 - 0.118 in)

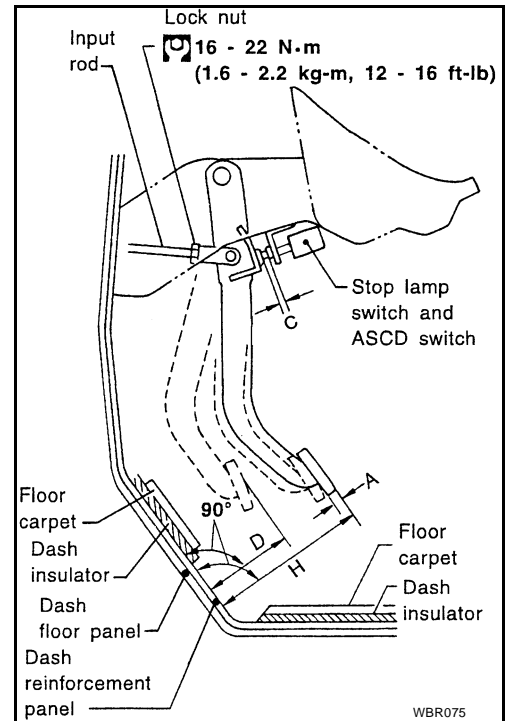

1. Loosen lock nut and adjust pedal free height by turning brake booster input rod. Then tighten lock nut.
2. Check pedal free play.

CAUTION:

Make sure that stop lamps go off when pedal is released.

3. Check brake pedal's depressed height while engine is running. If lower than specification, check brake system for leaks, accumulation of air or any damage to components (master cylinder, wheel cylinder, etc.); then make necessary repairs.

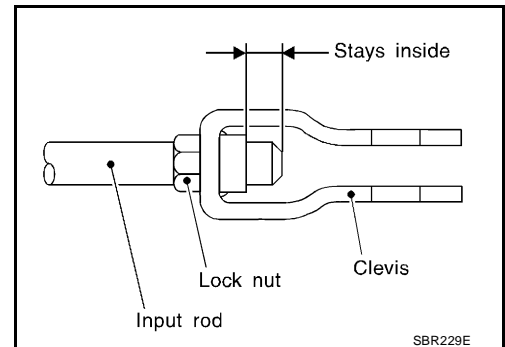

STOP LAMP SWITCH AND ASCD CANCEL SWITCH CLEARANCE

1. Twist and pull to remove switch.
2. Pull up on brake pedal pad and hold.
3. Insert switch into retainer until switch plunger is completely depressed.
4. Turn the switch until it locks into place in the brake pedal bracket.

NOTE:

When turning the switch to lock into place, the switch backs off the stopper to the correct clearance automatically.

5. Release the brake pedal pad.

MASTER CYLINDER

PFP:46010

MASTER CYLINDER

Removal

EFS00234

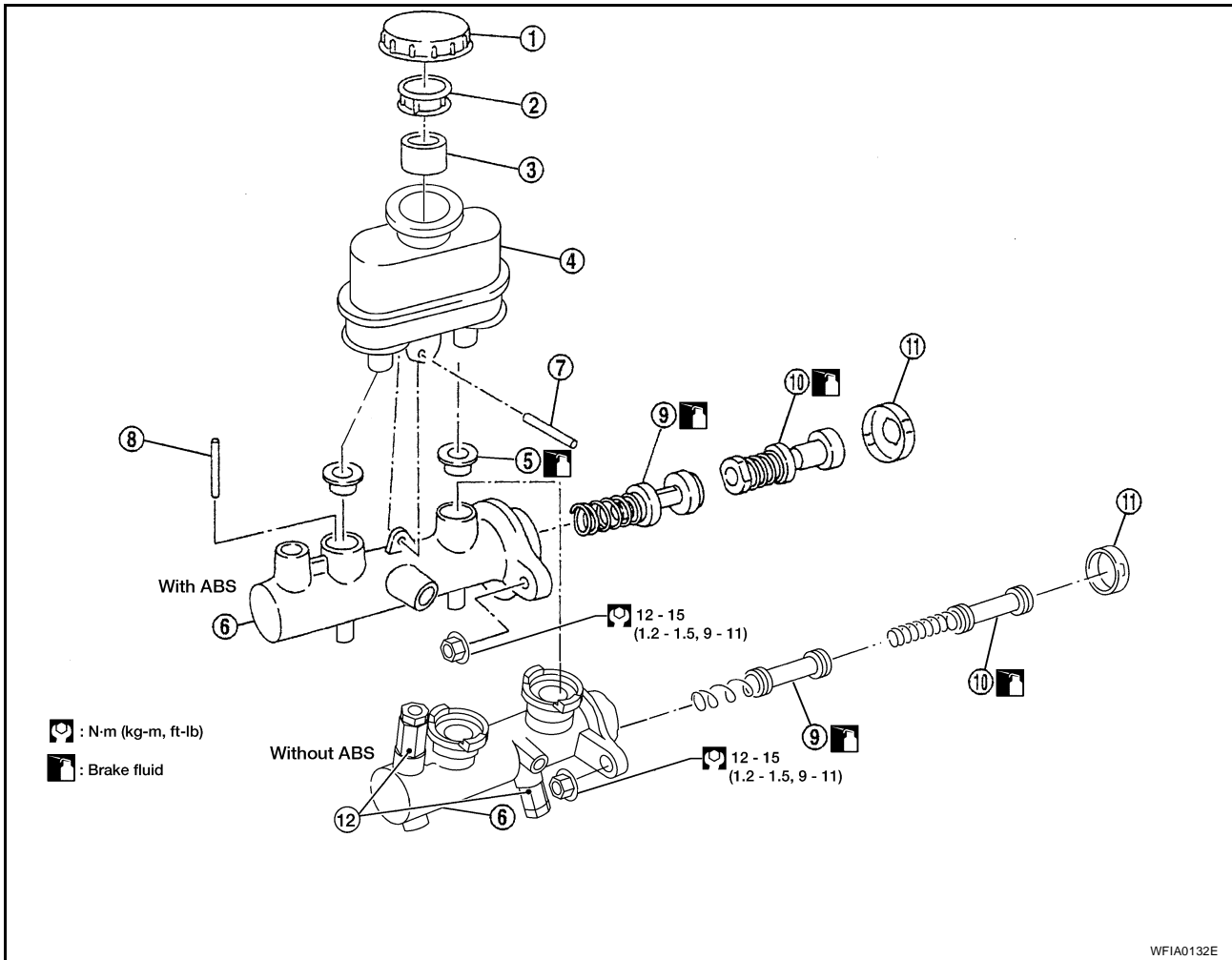

- | | | |
|-----------------------------|----------------------------------|---------------------------------------|
| 1. Reservoir cap | 2. Oil filter | 3. Float |
| 4. Reservoir tank | 5. Seal | 6. Cylinder body |
| 7. Spring pin (with ABS) | 8. Piston stopper pin (with ABS) | 9. Secondary piston assembly |
| 10. Primary piston assembly | 11. Stopper cap | 12. Proportioning valve (without ABS) |

CAUTION:

Be careful not to splash brake fluid on painted areas; it may cause paint damage. If brake fluid is splashed on painted areas, wash it away with water immediately.

1. Connect a vinyl tube to air bleeder valve.
2. Drain brake fluid from each air bleeder valve, depressing brake pedal to empty fluid from master cylinder.
3. Remove brake line flare nuts from master cylinder.
4. Remove master cylinder mounting nuts.

MASTER CYLINDER

Disassembly

EFS00235

1. Bend claws of stopper cap outward and remove stopper cap.

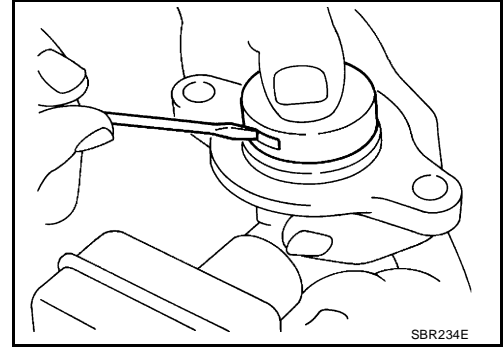

2. Drive out spring pin from cylinder body (with ABS).
3. Draw out reservoir tank and seals.

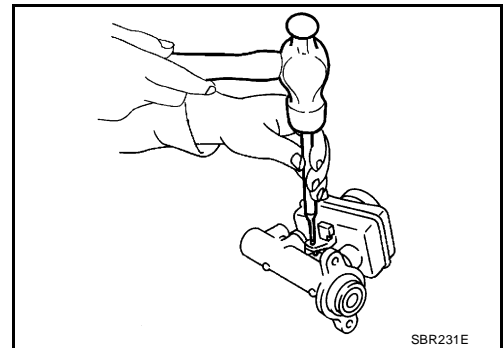

4. Remove piston stopper pin while piston is pushed into cylinder (with ABS).
5. Remove piston assemblies.
 - If it is difficult to remove secondary piston assembly, gradually apply compressed air through fluid outlet.

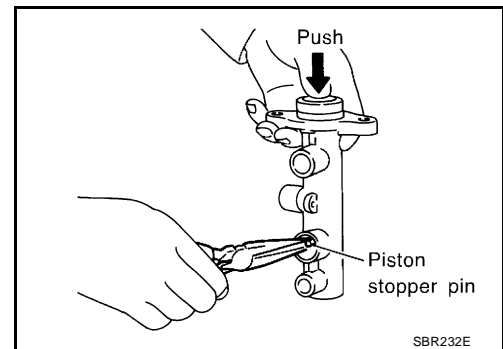

Inspection

Check for the following items.

Replace any part if damaged.

Master cylinder:

- Pin holes or scratches on inner wall.

Piston:

- Deformation of or scratches on piston cups.

Assembly

EFS00237

1. Insert secondary piston assembly. Then insert primary piston assembly.
 - Lubricate with brake fluid.
 - Pay attention to alignment of secondary piston slit with valve stopper mounting hole of cylinder body (with ABS).

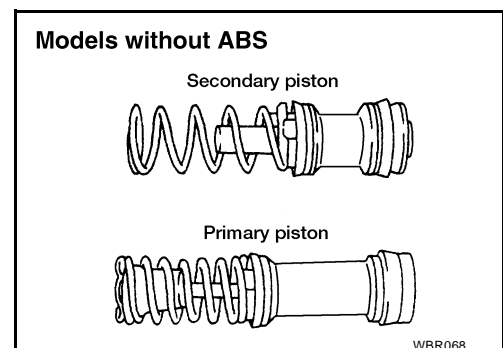

MASTER CYLINDER

2. Install piston stopper pin while piston is pushed into cylinder (with ABS).
3. Push reservoir tank seals and reservoir tank into cylinder body.
 - Lubricate with brake fluid.
4. Install spring pin (with ABS).

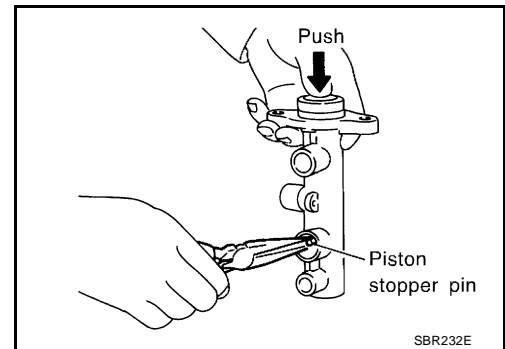
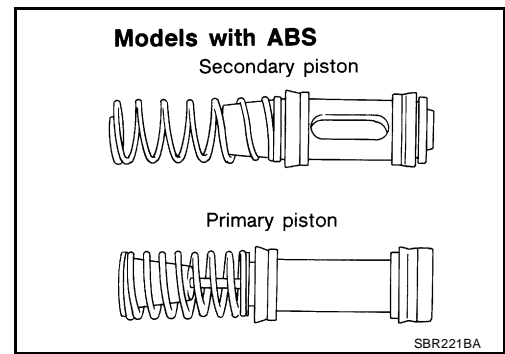

5. Install stopper cap.
 - **Before installing stopper cap, ensure that claws are bent inward.**

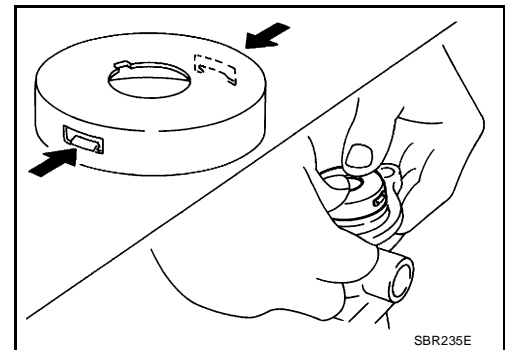

Installation

1. Place master cylinder onto brake booster and secure mounting nuts lightly.
2. Tighten master cylinder mounting nuts.

Master cylinder : 12 - 15 N·m (1.2 - 1.5 kg·m, 9 - 11 ft·lb)

3. Fill reservoir tank with new brake fluid.

CAUTION:

- Refill with new brake fluid "DOT 3".
- Never reuse drained brake fluid.

4. Plug all ports on master cylinder with fingers to prevent air suction while releasing brake pedal.
5. Have driver depress brake pedal slowly several times until no air comes out of master cylinder.
6. Fit brake lines to master cylinder.
7. Tighten flare nuts.

Flare nuts : 15 - 18 N·m (1.5 - 1.8 kg·m, 11 - 13 ft·lb)

8. Bleed air from brake system. Refer to [BR-7, "Bleeding Brake System"](#).

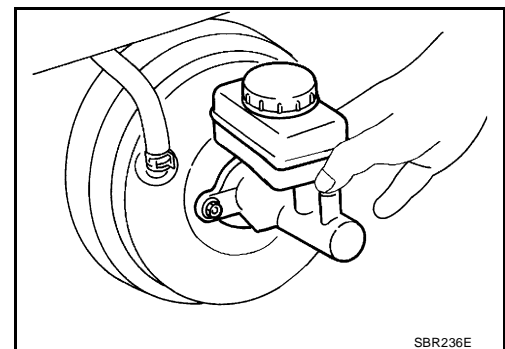

BRAKE BOOSTER

PFP:47200

BRAKE BOOSTER

On-vehicle Service OPERATING CHECK

EFS00239

1. Stop engine and depress brake pedal several times. Check that pedal stroke does not change.
2. Depress brake pedal, then start engine. If pedal goes down slightly, operation is normal.

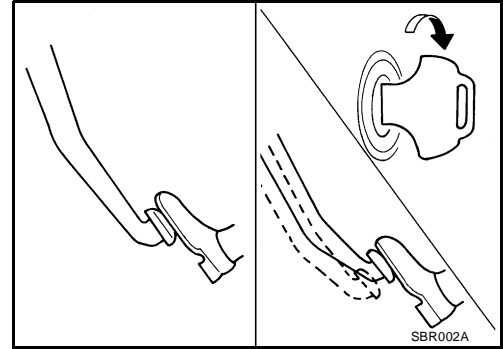

AIRTIGHT CHECK

1. Start engine, and stop it after one or two minutes. Depress brake pedal several times slowly. The pedal should go further down the first time, and then it should gradually rise thereafter.
2. Depress brake pedal while engine is running, and stop engine with pedal depressed. The pedal stroke should not change after holding pedal down for **30 seconds**.

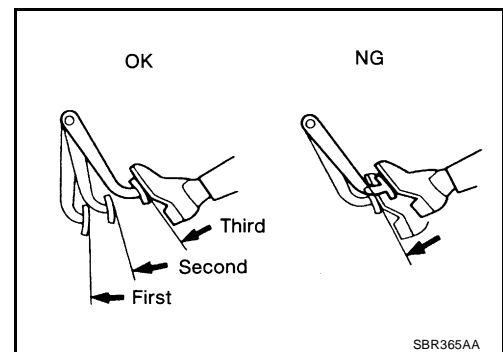

Removal

EFS0023A

CAUTION:

- Be careful not to splash brake fluid on painted areas; it may cause paint damage. If brake fluid is splashed on painted areas, wash it away with water immediately.
- Be careful not to deform or bend brake lines, during removal of booster.
- Replace clevis pin if it is damaged.
- Be careful not to damage brake booster stud bolt threads. If brake booster is tilted or inclined during installation, the dash panel may damage the threads.
- Attach the check valve in the correct orientation.

1. Remove strut tower bar, if equipped. Refer to [FSU-5, "Components"](#).
2. Remove air cleaner and inlet duct. Refer to [EM-106, "Removal and Installation"](#).
3. Remove the brake master cylinder. Refer to [BR-13, "Removal"](#).
4. Remove vacuum hose from the brake booster. Refer to [BR-18, "Removal and Installation"](#).
5. Remove lower driver instrument panel. Refer to [IP-10, "Removal and Installation"](#).
6. Remove the brake pedal attachment snap pin and clevis pin from inside the vehicle.
7. Remove the nuts on the brake booster and brake pedal assembly.
8. Remove brake booster assembly from the engine compartment side.

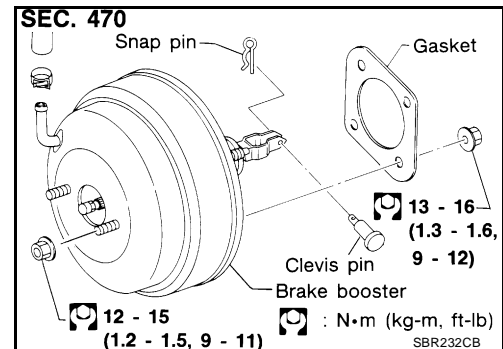

BRAKE BOOSTER

Inspection

OUTPUT ROD LENGTH CHECK

EFS0023B

1. Apply vacuum of -66.7 kPa (-500 mmHg, -19.69 inHg) to brake booster with a hand vacuum pump.
2. Add preload of 19.6 N (2 kg, 4.4 lb) to output rod.
3. Check output rod length.

**Specified length : 10.275 - 10.525 mm
(0.4045 - 0.4144 in)**

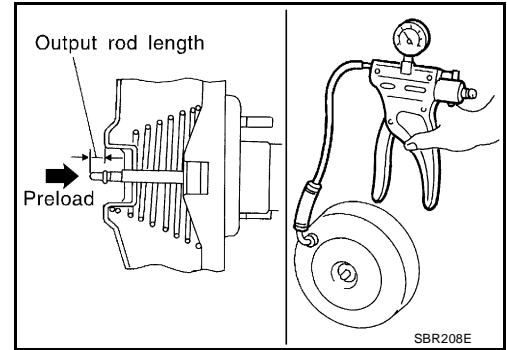

Installation

EFS0023C

CAUTION:

- Be careful not to deform or bend brake lines, during installation of booster.
- Replace clevis pin if damaged.
- Refill with new brake fluid "DOT 3".
- Never reuse drained brake fluid.
- Take care not to damage brake booster mounting bolt thread when installing. Due to the acute angle of installation, the threads can be damaged with the dash panel.

1. Before fitting booster, temporarily adjust clevis to dimension shown.
2. Fit booster, then secure mounting nuts (brake pedal bracket to master cylinder) lightly.
3. Connect brake pedal and booster input rod with clevis pin.
4. Install and tighten brake booster mounting nuts to specification.

Brake booster : 13 - 16 N·m (1.3 - 1.6 kg·m, 9 - 12 ft·lb)

5. Install master cylinder. Refer to [BR-15, "Installation"](#).
6. Connect brake booster vacuum hose.
7. Adjust brake pedal height. Refer to [BR-12, "BRAKE PEDAL HEIGHT"](#).
8. Bleed air from brake system. Refer to [BR-7, "Bleeding Brake System"](#).

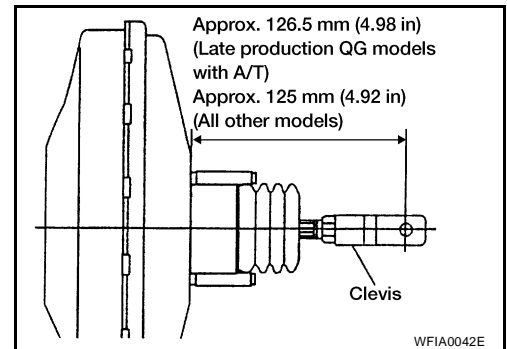

VACUUM HOSE

PFP:41920

VACUUM HOSE

Removal and Installation

EFS0023D

CAUTION:

When installing vacuum hoses, pay attention to the following points:

- Do not apply any oil or lubricants to vacuum hose with check valve.
- Insert vacuum tube into vacuum hose as shown.
- Install vacuum hose with the internal check valve oriented in the correct direction. The arrow on the hose should point to the engine connection.

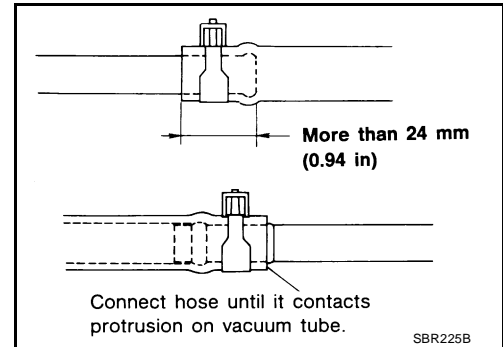

EFS0023E

Inspection

HOSES AND CONNECTORS

Check vacuum lines and connections for airtightness, improper attachment, chafing and deterioration.

CHECK VALVE

Check vacuum with a vacuum pump.

Connect to booster side	Vacuum should exist
Connect to engine side	Vacuum should not exist

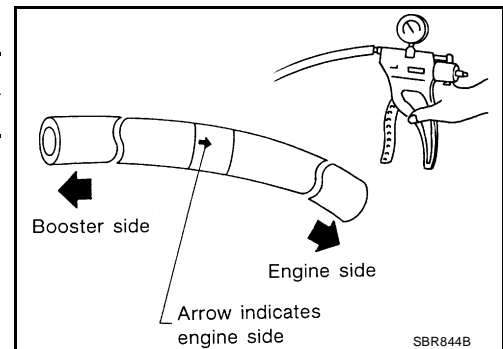

FRONT DISC BRAKE (CL25VA/CL25VB TYPE)

FRONT DISC BRAKE (CL25VA/CL25VB TYPE)

PF0:41000

EFS00321

On-board Inspection PAD WEAR INSPECTION

- Inspect the thickness of the pad through the caliper inspection hole. Use a ruler or caliper for inspection if necessary.

Standard

Standard thickness : 11 mm (0.433 in)

Repair limit thickness : 2.0 mm (0.079 in)

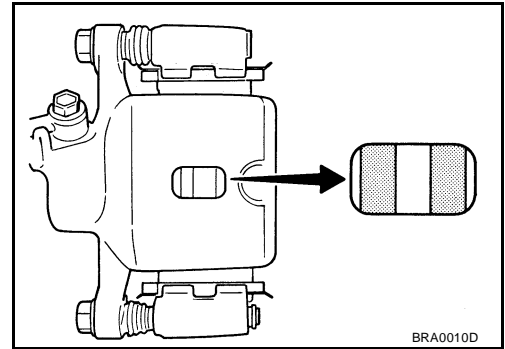

BRA0010D

Component

EFS0031R

SEC. 440

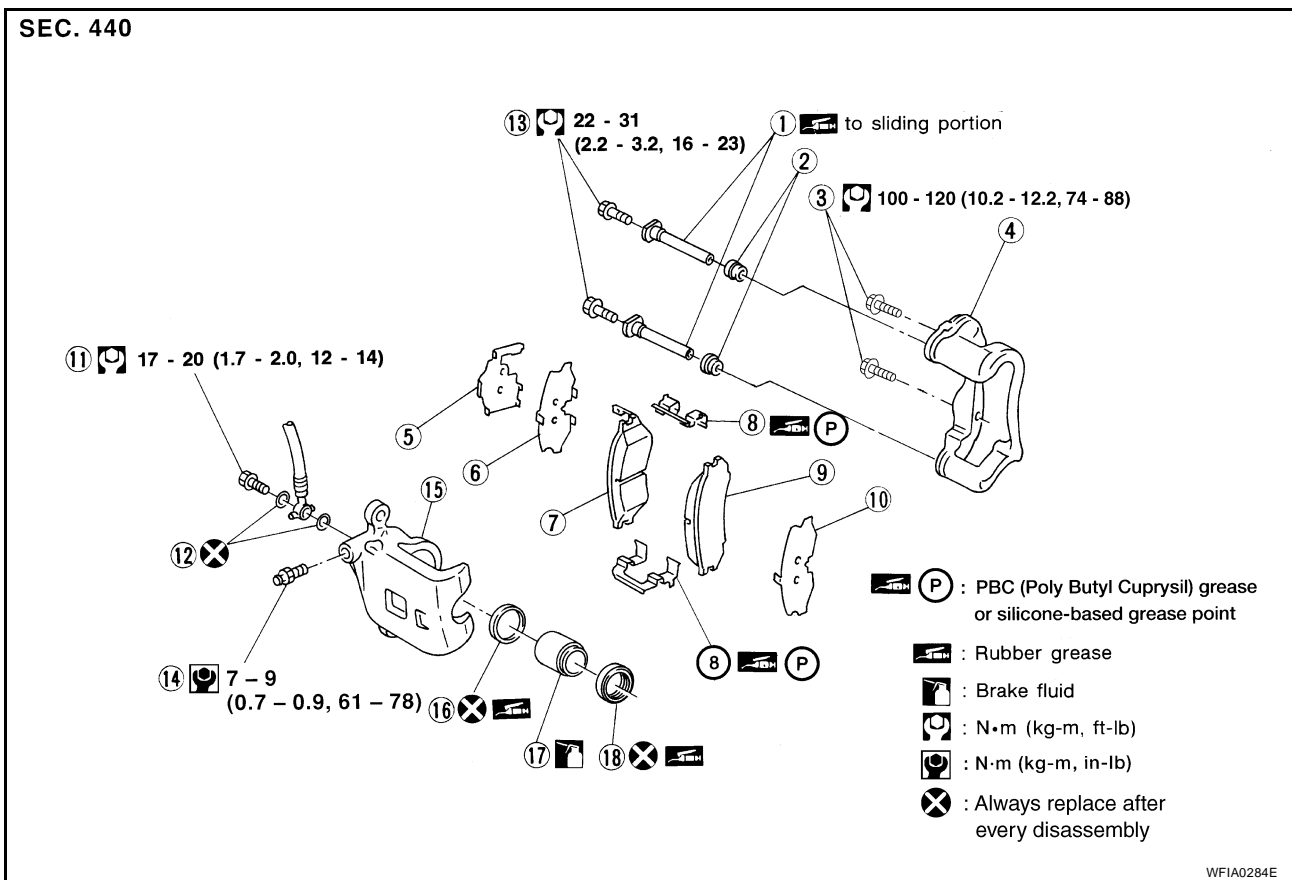

WFIA0284E

- | | | |
|-------------------|-----------------------|------------------------------|
| 1. Main pin | 2. Pin boot | 3. Torque member fixing bolt |
| 4. Torque member | 5. Shim cover | 6. Inner shim |
| 7. Inner pad | 8. Pad retainer | 9. Outer pad |
| 10. Outer shim | 11. Connecting bolt | 12. Copper washer |
| 13. Main pin bolt | 14. Air bleeder valve | 15. Cylinder body |
| 16. Piston seal | 17. Piston | 18. Piston boot |

Pad Replacement

EFS0031S

WARNING:

Clean brake pads with a vacuum dust collector to minimize the hazard of airborne particles or other materials.

CAUTION:

- When cylinder body is open, do not depress brake pedal because piston will pop out.

FRONT DISC BRAKE (CL25VA/CL25VB TYPE)

- Be careful not to damage piston boot or get oil on rotor. Always replace shims when replacing pads.
 - If shims are rusted or show peeling of the rubber coat, replace them with new shims.
1. Remove master cylinder reservoir cap.
 2. Remove wheel and tire. Refer to [MA-34, "Tire Rotation"](#).
 3. Remove pin bolt.

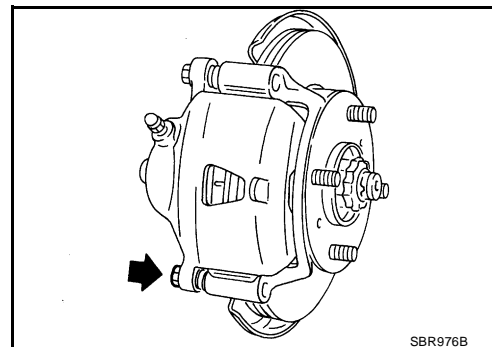

4. Open cylinder body upward. Then remove pad with retainers, inner and outer shims.
 - It is not necessary to remove connecting bolt except for disassembly or replacement of caliper assembly. In this case, suspend cylinder body with wire so as not to stretch brake hose.
5. Reverse the removal procedure to install.
 - **Burnish the brake contact surfaces after refinishing or replacing drums or rotors, after replacing pads or linings, or if a soft pedal occurs at very low mileage.**
Refer to [BR-7, "Brake Burnishing Procedure"](#).

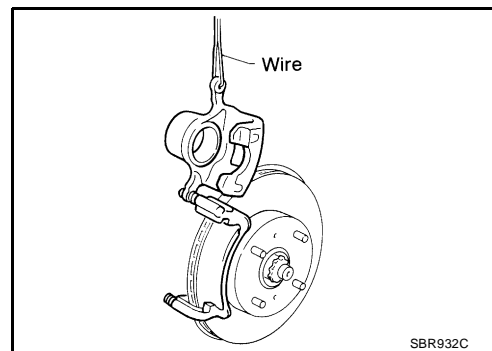

NOTE:

Carefully monitor brake fluid level because brake fluid will return to reservoir when pushing back piston.

Removal and Installation of Caliper Assembly and Disc Rotor

EFS00322

REMOVAL

1. Remove wheel and tire. Refer to [MA-34, "Tire Rotation"](#).
2. Drain brake fluid. Refer to [BR-6, "Changing Brake Fluid"](#).
3. Remove torque member fixing bolts and brake hose connecting bolt.

WARNING:

Clean brake pads with a vacuum dust collector to minimize the hazard of airborne particles or other materials.

- It is not necessary to remove brake hose connecting bolt except for disassembly or replacement of caliper assembly. In this case, suspend caliper assembly with wire so as not to stretch brake hose.
4. Remove disc rotor.

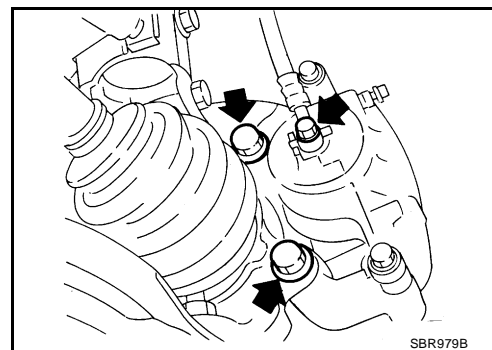

FRONT DISC BRAKE (CL25VA/CL25VB TYPE)

INSTALLATION

CAUTION:

- Refill with new brake fluid "DOT 3".
 - Never reuse drained brake fluid.
1. Install disc rotor.
 2. Install brake hose to caliper and tighten connecting bolt to specification. Refer to [BR-19, "Component"](#).

CAUTION:

Install new copper washers.

3. Install all parts and tighten all bolts. Refer to [BR-19, "Component"](#).
4. Bleed air from brake system. Refer to [BR-7, "Bleeding Brake System"](#).

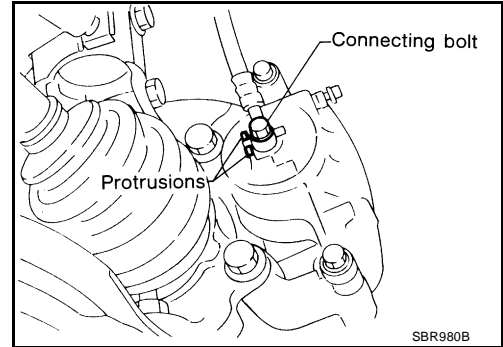

EFS00323

Disassembly and Assembly of Caliper Assembly

DISASSEMBLY

1. Push out piston with piston boot with compressed air.

WARNING:

Do not place your fingers in front of piston.

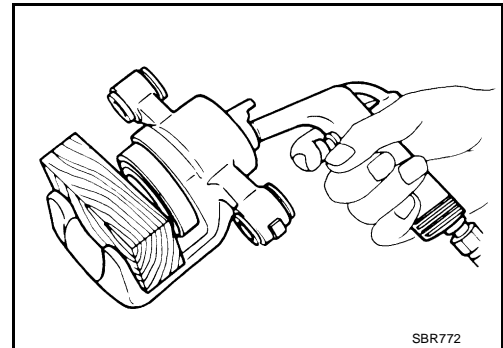

2. Remove piston seal with a suitable tool.

CAUTION:

Do not scratch or score cylinder wall.

3. Remove the pad retainer.

CAUTION:

When removing the pad retainer from the torque member, lift it up and out in the direction of the arrows in the figure.

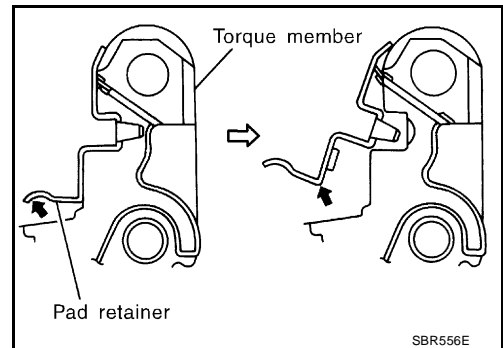

CALIPER INSPECTION

Cylinder Body

CAUTION:

- Check inside surface of cylinder for score, rust, wear, damage or presence of foreign materials. If any of the above conditions are observed, replace cylinder body.
- Minor damage from rust or foreign materials may be eliminated by polishing surface with a fine emery paper. Replace cylinder body if necessary.

Use brake fluid to clean. Never use mineral oil.

FRONT DISC BRAKE (CL25VA/CL25VB TYPE)

Piston

CAUTION:

Piston sliding surface is plated. Do not polish with emery paper even if rust or foreign materials are stuck to sliding surface.

- Check piston for score, rust, wear, damage or presence of foreign materials. Replace if any of the above conditions are observed.

Slide Pin, Pin Bolt and Pin Boot

Check for wear, cracks or other damage. Replace if any of the above conditions are observed.

DISC ROTOR INSPECTION

Rubbing Surface

Check rotor for roughness, cracks or chips.

Runout

1. Secure rotor to wheel hub with at least two nuts (M12 x 1.25).
2. Check runout using a dial indicator.

CAUTION:

Make sure that wheel bearing axial end play is within the specifications before measuring. Refer to [FAX-5, "Front Wheel Bearing"](#)

Maximum runout : 0.07 mm (0.0028 in)

3. If the runout is out of specification, find minimum runout mounting position as follows:
 - a. Remove nuts and rotor from wheel hub.
 - b. Shift the rotor one hole and secure rotor to wheel hub with nuts.
 - c. Measure runout.
 - d. Repeat steps a. to c. so that minimum runout position can be found.
4. If the runout is still out of specification, turn rotor with on-car brake lathe ("MAD, DL-8700", "AMMCO 700 and 705" or equivalent).

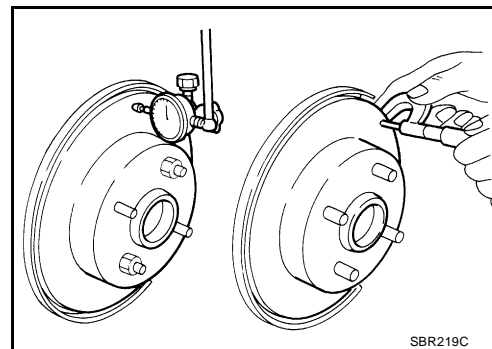

Thickness

**Thickness variation :Maximum 0.01 mm (0.0004 in)
(At least 8 positions)**

- If rotor thickness variation exceeds the specification, turn rotor with on-car brake lathe.

**Rotor thickness : 20 mm (0.79 in)
repair limit**

ASSEMBLY

1. Insert piston seal into groove in cylinder body.
2. With piston boot fitted to piston, insert piston boot into groove on cylinder body and install piston.
3. Properly secure piston boot.

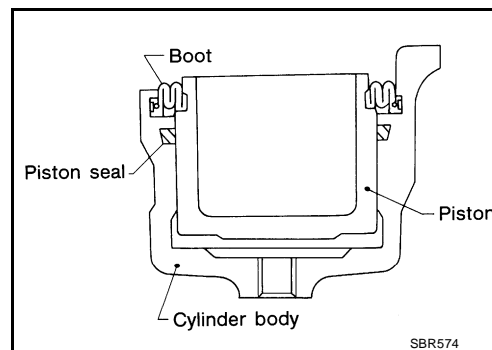

FRONT DISC BRAKE (OPB27VA TYPE)

FRONT DISC BRAKE (OPB27VA TYPE)

PFP:41000

On-board Inspection PAD WEAR INSPECTION

EFS0031J

- Inspect the thickness of the pad through the caliper inspection hole. Use a ruler or caliper for inspection if necessary.

Standard

Standard thickness : 9.3 mm (0.366 in)

Repair limit thickness : 2.0 mm (0.079 in)

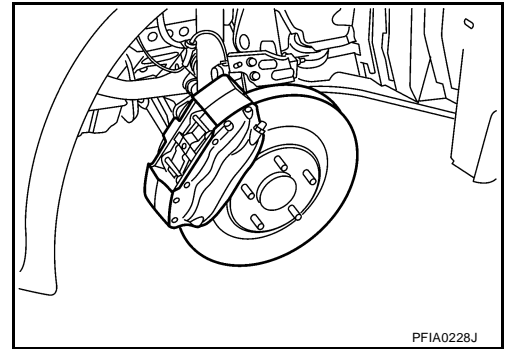

PFI A0228J

Component

EFS0031K

NOTE:

Refer to [BR-25. "HOW TO APPLY GREASE TO THE BRAKE PAD"](#) for how to apply grease to brake pads.

SEC.440

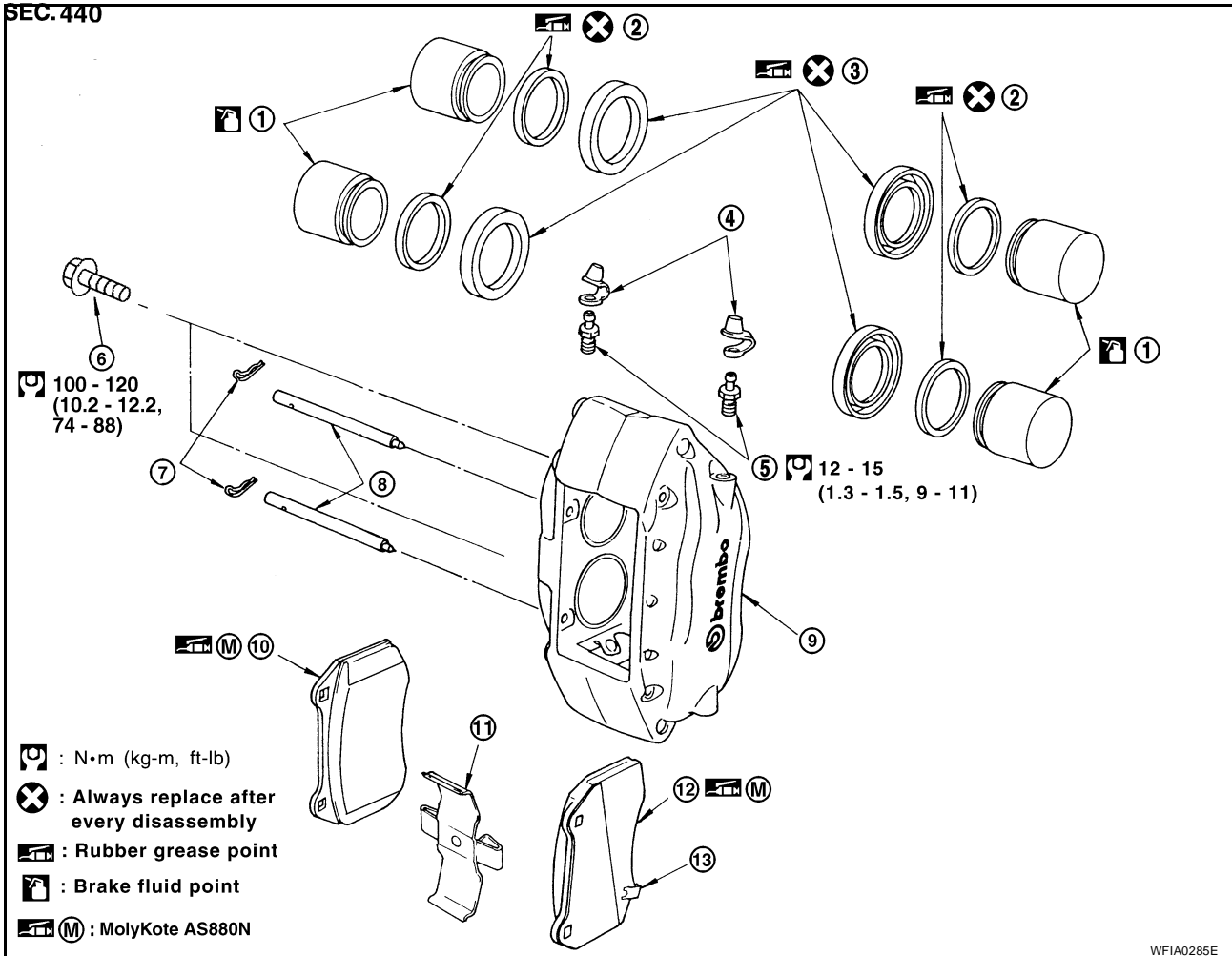

WFIA0285E

- | | | |
|---------------------|---------------------|----------------|
| 1. Piston | 2. Piston seal | 3. Piston boot |
| 4. Cap | 5. Air bleeder | 6. Bolt |
| 7. Clips | 8. Pad pins | 9. Caliper |
| 10. Inner pad | 11. Cross spring | 12. Outer pad |
| 13. Pad wear sensor | 14. Pad wear sensor | |

FRONT DISC BRAKE (OPB27VA TYPE)

CAUTION:

- Clean dust on caliper and brake pad with a vacuum dust collector. Do not blow with compressed air.
- While the brake pad and cylinder body are separated, the piston may suddenly jump out, so do not depress the brake pedal.
- Apart from caliper assembly, disassembly or replacement, there is no need to remove caliper bolts or brake hose or tube.
- Do not damage piston boot.
- Keep the rotor clean of brake fluid.

Pad Replacement REMOVAL

EFS0031L

1. Remove wheels and tires from vehicle. Refer to [WT-5, "Rotation"](#).
2. Remove the clips from the pad pins using a suitable tool.

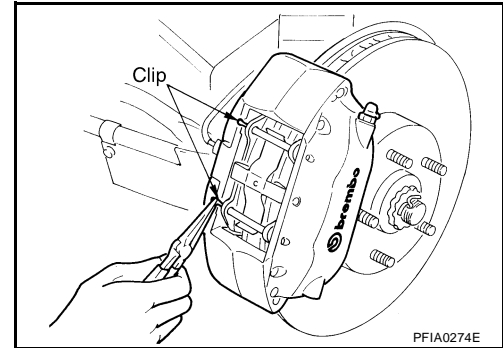

3. Remove the pad pins while holding down the cross spring, then remove the cross spring from the caliper.

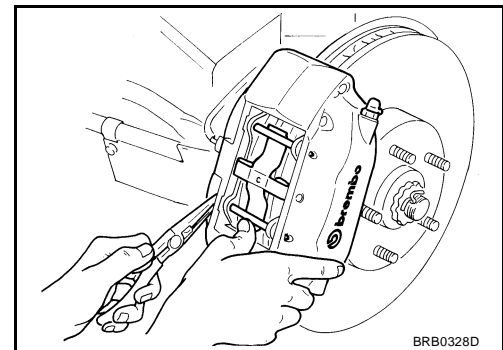

4. Remove the pad from the caliper.

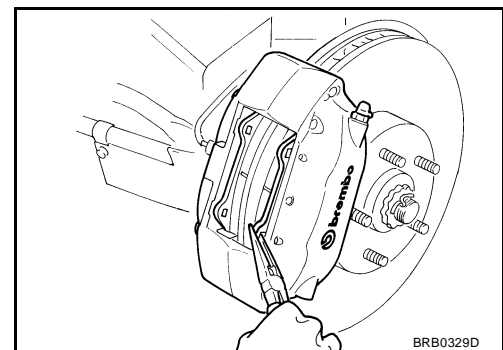

FRONT DISC BRAKE (OPB27VA TYPE)

HOW TO APPLY GREASE TO THE BRAKE PAD

Pad Side

Apply Molykote AS880N grease or silicone-based grease about 0.5 g (0.018 oz) per surface equally to back plate side of Inner Pad and Outer Pad as shown.

CAUTION:

Make sure no foreign material contaminates the grease.

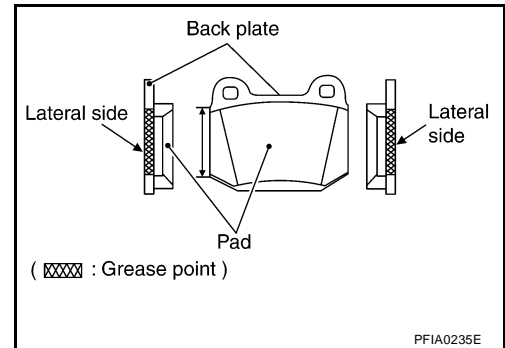

INSTALLATION

1. Insert the piston to the position where the pad is attached.

CAUTION:

By pushing in the piston, the brake fluid returns to the master cylinder reservoir tank. Watch the level of the surface of the reservoir tank.

NOTE:

Using a disc brake piston tool (commercial service tool), etc., makes it easier to push in the piston.

2. Install pad as shown.

CAUTION:

- Attach the pad with wear sensor to the outer side.
- The side of the shim with the larger cutouts should be on the entry side of the disc rotor rotation.

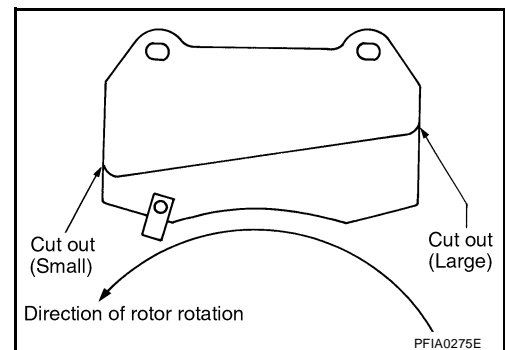

3. Insert the upper pad pin from the inner cylinder side, then insert firmly to the outer cylinder side through the hole in the top of the pad.
4. Place the top of the cross spring over the top pad pin, press in the cross spring, push the lower pad pin from the inner cylinder side to the outer cylinder side, and secure the cross spring as shown.
5. Insert the clips in the small hole at the end of the pad pins.

CAUTION:

If the clip is not fully attached, the pad pin or the pad could fall out while the vehicle is in motion.

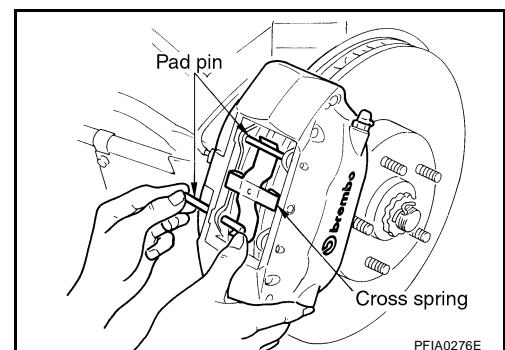

6. Install the wheels and tires to the vehicle. Refer to [WT-5, "Rotation"](#).

FRONT DISC BRAKE (OPB27VA TYPE)

EFS0031M

Removal and Installation of Caliper Assembly and Disc Rotor

REMOVAL

1. Remove wheels and tires from vehicle. Refer to [WT-5, "Rotation"](#) .
2. Drain brake fluid. Refer to [BR-6, "Changing Brake Fluid"](#) .
3. Remove the brake pad. Refer to [BR-24, "Pad Replacement"](#) .
4. Remove the brake tube flare nut using a flare wrench.

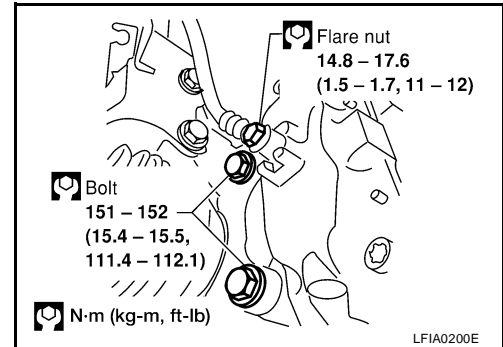

5. Remove the caliper bolt and remove the caliper assembly from the vehicle.
6. Remove disc rotor.

INSTALLATION

CAUTION:

- Refill with new brake fluid "DOT3"
- Never reuse drained brake fluid.

1. Install disc rotor.

CAUTION:

Install new copper washers.

2. Install caliper assembly to the vehicle, and tighten bolts to the specified torque.

CAUTION:

When attaching the caliper assembly to the vehicle, wipe any oil off the knuckle spindle washers and caliper assembly attachment surfaces.

3. Attach the brake tube to the caliper assembly and partially tighten the flare nut.
4. Using a flare nut torque wrench, tighten the caliper assembly and brake tube connection flare nut to the specified torque.

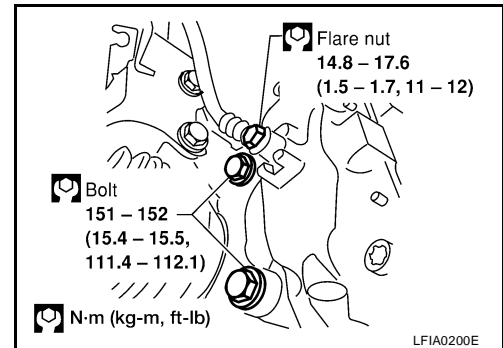

5. Attach brake pad. Refer to [BR-24, "Pad Replacement"](#) .
6. Refill new brake fluid and bleed air. Refer to [BR-7, "Bleeding Brake System"](#) .
7. Install the wheels and tires to the vehicle. Refer to [WT-5, "Rotation"](#) .

Disassembly and Assembly of Caliper Assembly

DISASSEMBLY

EFS0031N

1. Insert a piece of wood as shown, blow air in through the flare nut mounting hole, and remove the piston and piston boot. If the four pistons do not all come out at the same time, press the piston(s) that have come out a ways into the cylinder body and blow air in again.

WARNING:

Do not get your fingers caught in the piston.

2. Remove the piston boot from the piston.

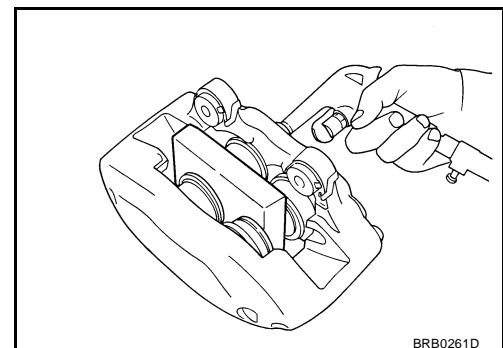

FRONT DISC BRAKE (OPB27VA TYPE)

- Using a screwdriver, remove the piston seal.

CAUTION:

- Be careful not to damage cylinder inner wall.
- Never remove the four bolts from the inner and outer sides of the caliper and do not tighten them further.

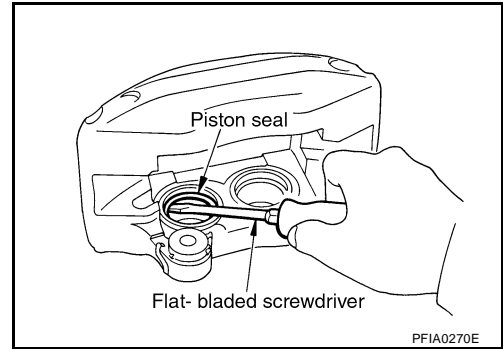

CALIPER INSPECTION

Caliper

CAUTION:

- Use new brake fluid to clean the caliper. Never use mineral oils such as gasoline or kerosene.
- Check for corrosion, wear, or damage to the cylinder inner wall, and replace the caliper as necessary.

Piston

CAUTION:

- The piston surface is plated, do not repair the piston using sandpaper.
- Check piston surface for corrosion, wear, and damage, and replace the caliper as necessary.

DISC ROTOR INSPECTION

Visual Inspection

Check surface of the disc rotor for uneven wear, cracks, and serious damage. If any non-standard condition is detected, replace applicable part.

Runout Inspection

- Using wheel nuts, attach disc rotor to the wheel hub using at least two wheel nuts.
- Inspect runout using a dial gauge.

Standard value

(measured at 10 mm (0.39 in) inside the disc edge)

Runout limit : 0.050 mm (0.0020 in) or less
(with it attached to the vehicle)

Runout limit (just the disc rotor) : 0.040 mm (0.0016 in) or less

CAUTION:

Before measuring, make sure the axle endplay is 0 mm (0 in).

- If runout is outside the limit, find the minimum runout point by shifting mounting positions of the disc rotor and wheel hub by one hole.

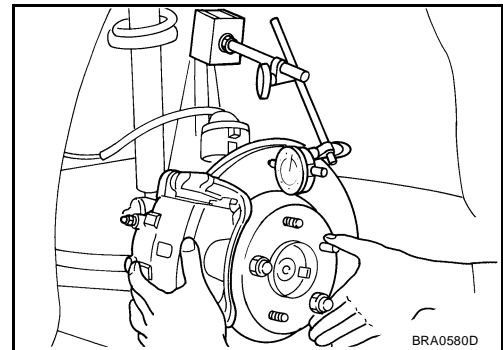

Thickness Inspection

Using a micrometer, check thickness of the disc rotor. If thickness is outside the standard, replace disc rotor.

Standard

Standard thickness : 22 mm (0.87 in)

Wear limit : 20 mm (0.79 in)

Maximum uneven wear : 0.015 mm (0.0006 in) or less
(measured at 8 positions)

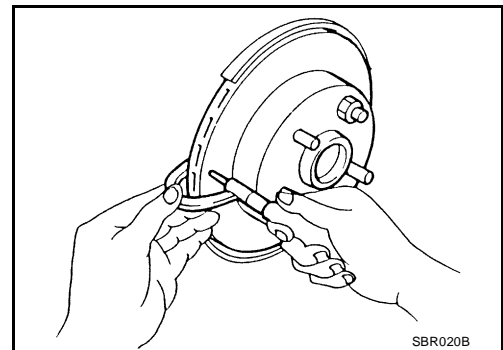

A
B
C
D
E
BR
G
H
I
J
K
L
M

FRONT DISC BRAKE (OPB27VA TYPE)

ASSEMBLY

1. Apply a rubber grease to the piston seal and attach to cylinder body. Refer to [MA-13, "RECOMMENDED FLUIDS AND LUBRICANTS"](#).

CAUTION:

Do not use Nissan Rubber Grease (KRE00 00010, KRE00 00010 01) when assembling.

CAUTION:

Do not reuse the piston seals.

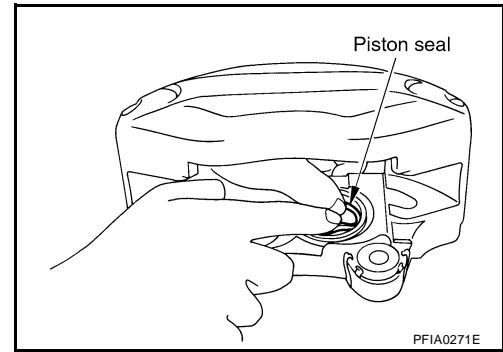

2. Apply brake fluid or rubber grease to the piston boot, place it on the piston, and firmly insert the piston boot cylinder-side lip into the cylinder body groove.
3. Insert the piston into the cylinder body by hand and firmly attach the piston boot piston-side lip into the piston groove.

CAUTION:

Press the piston evenly and vary the pressing point to prevent cylinder inner wall from being rubbed.

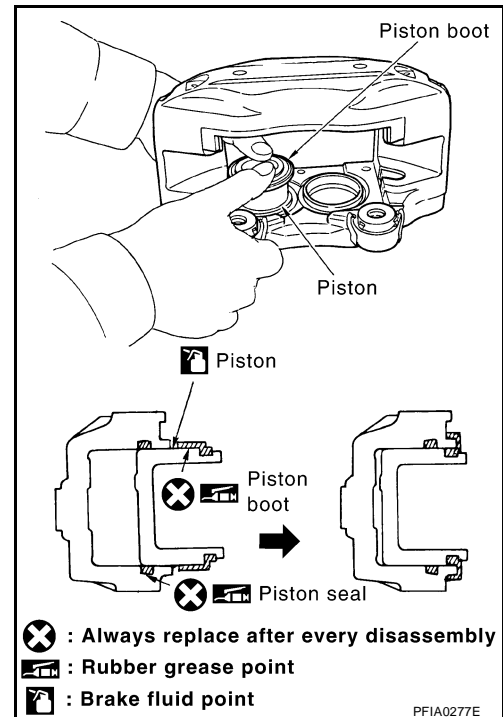

4. Attach the shim and shim cover to the pad and attach to the caliper.

REAR DISC BRAKE

PF:44000

EFS0037T

REAR DISC BRAKE

On-board Inspection PAD WEAR INSPECTION

- Inspect the thickness of the pad through the caliper inspection hole. Use a ruler or caliper for inspection if necessary.

Standard

Standard thickness : 10 mm (0.39 in)

Repair limit thickness : 2.0 mm (0.079 in)

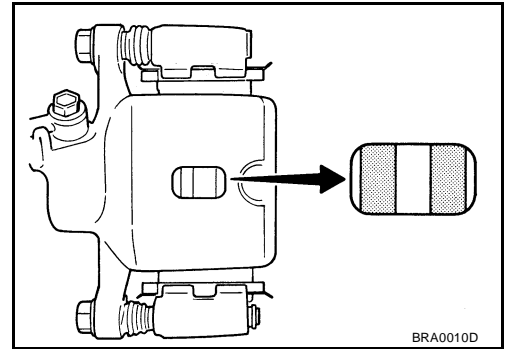

Component

EFS0023M

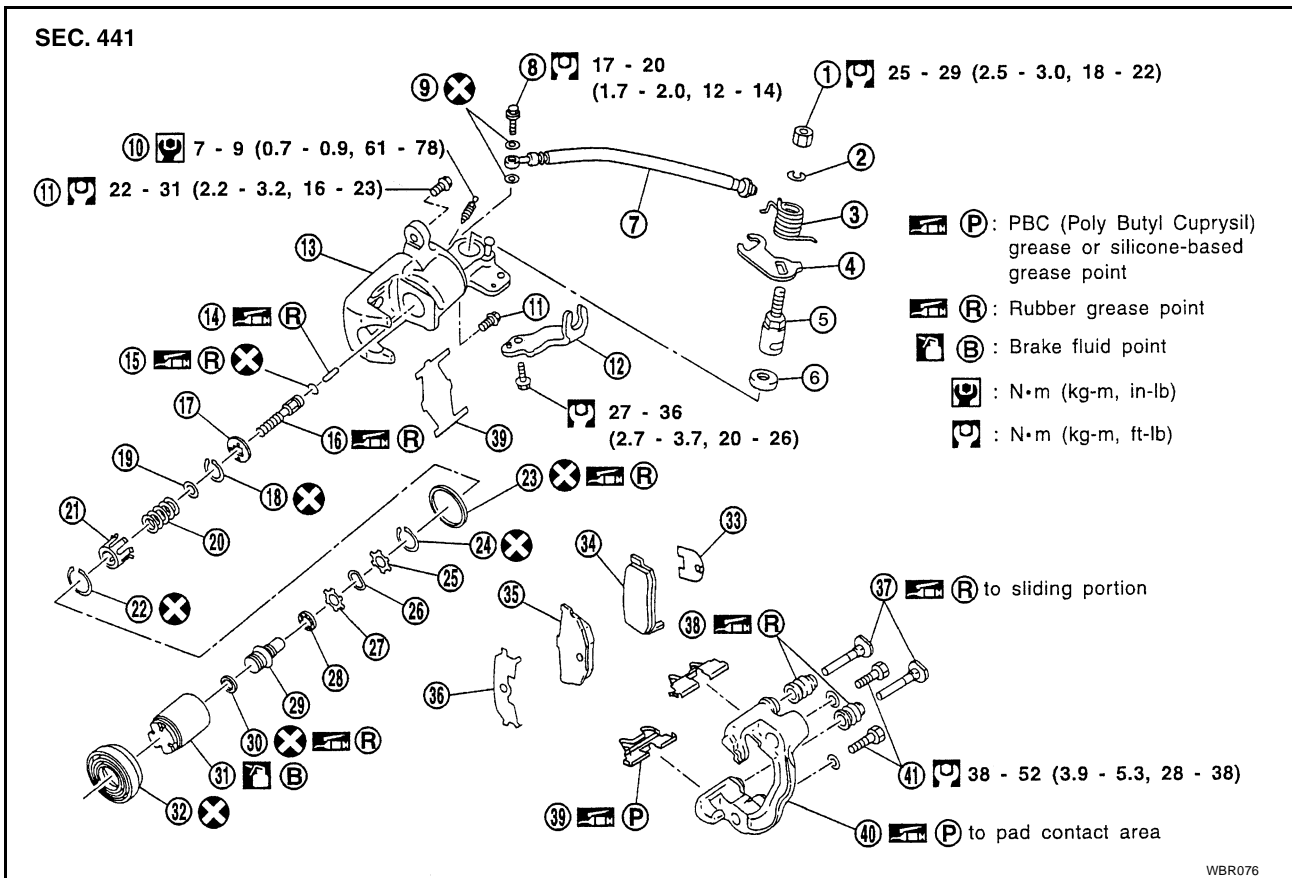

WBR076

- | | | |
|-----------------------|--------------------|-------------------|
| 1. Nut | 2. Washer | 3. Return spring |
| 4. Toggle lever | 5. Cam | 6. Cam boot |
| 7. Brake hose | 8. Connecting bolt | 9. Copper washers |
| 10. Air bleeder valve | 11. Pin bolt | 12. Cable guide |
| 13. Cylinder body | 14. Strut | 15. O-ring |
| 16. Push rod | 17. Key plate | 18. Ring C |
| 19. Seat | 20. Spring | 21. Spring cover |
| 22. Ring B | 23. Piston seal | 24. Ring A |
| 25. Spacer | 26. Wave washer | 27. Spacer |
| 28. Ball bearing | 29. Adjuster | 30. Cup |
| 31. Piston | 32. Piston boot | 33. Inner shim |
| 34. Inner pad | 35. Outer pad | 36. Outer shim |

REAR DISC BRAKE

- 37. Pin
- 40. Torque member

- 38. Pin boot
- 41. Torque member fixing bolt

- 39. Pad retainer

EFS0023N

Pad Replacement

WARNING:

Clean brake pads with a vacuum dust collector to minimize the hazard of airborne particles or other materials.

CAUTION:

- When cylinder body is open, do not depress brake pedal because piston will pop out.
- Be careful not to damage piston boot or get oil on rotor. Always replace shims in replacing pads.
- If shims are rusted or show peeling of rubber coat, replace them with new shims.
- It is not necessary to remove connecting bolt except for disassembly or replacement of caliper assembly. In this case, suspend cylinder body with wire so as not to stretch brake hose.
- Burnish the brake contact surfaces after refinishing or replacing drums or rotors, after replacing pads or linings, or if a soft pedal occurs at very low mileage.

Refer to [BR-7, "Brake Burnishing Procedure"](#) .

1. Remove master cylinder reservoir cap.
2. Remove wheel and tire. Refer to [MA-34, "Tire Rotation"](#) .
3. Remove brake cable mounting bolt and lock spring.

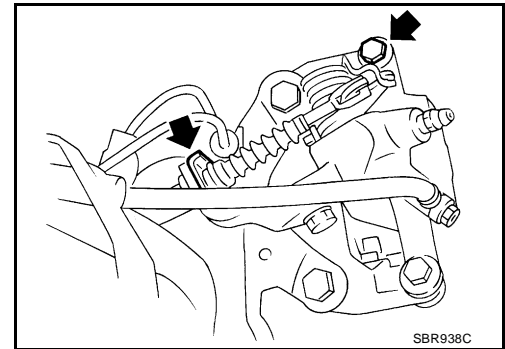

4. Release parking brake control lever, then disconnect cable from the caliper.
5. Remove upper pin bolt.
6. Open cylinder body downward and secure with wire as shown. Then remove pad retainers, and inner and outer shims.

Standard pad thickness : 10 mm (0.39 in)
Pad wear limit : 2.0 mm (0.079 in)

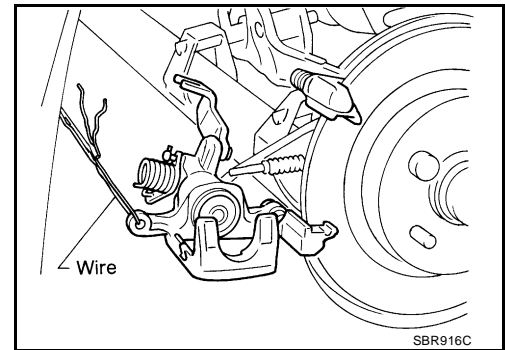

7. When installing new pads, push piston into cylinder body by gently turning piston clockwise using suitable commercial service tool or long nose pliers, as shown.

NOTE:

Carefully monitor brake fluid level because brake fluid will return to reservoir when pushing back piston.

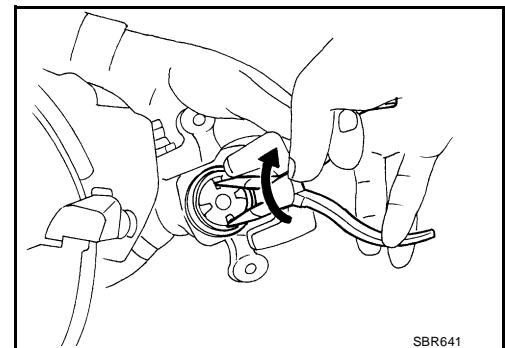

REAR DISC BRAKE

8. Adjust the piston to the right angle as shown.

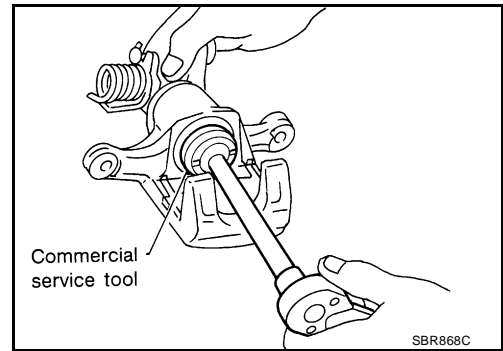

9. Install caliper assembly.
- As shown in the figure, align the piston's concave to the pad's convex, then install the cylinder body to the torque member.

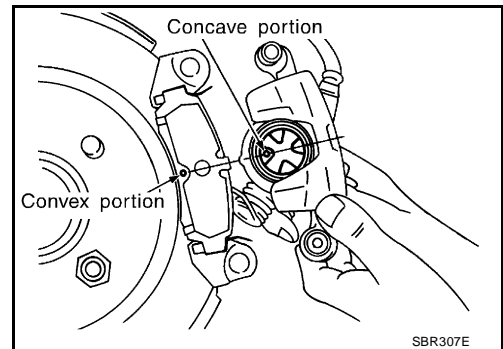
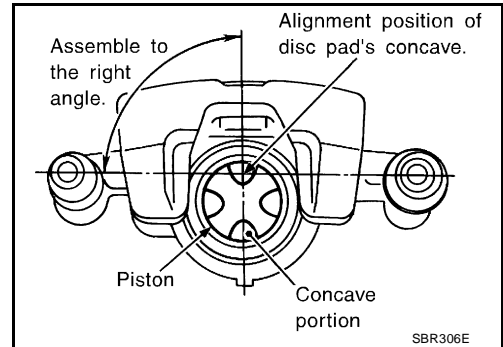

Removal and Installation of Caliper Assembly and Disc Rotor

EFS00230

REMOVAL

WARNING:
Clean brake pads with a vacuum dust collector to minimize the hazard of airborne particles or other materials.

1. Remove wheel and tire. Refer to [MA-34, "Tire Rotation"](#).
2. Remove brake cable mounting bolt and lock spring.
3. Release parking brake control lever, then disconnect cable from the caliper.
4. Remove torque member fixing bolts and brake hose connecting bolt.

NOTE:

It is not necessary to remove brake hose connecting bolt except for disassembly or replacement of caliper assembly. In this case, suspend caliper assembly with wire so as not to stretch brake hose.

5. Remove caliper assembly.
6. Remove disc rotor.

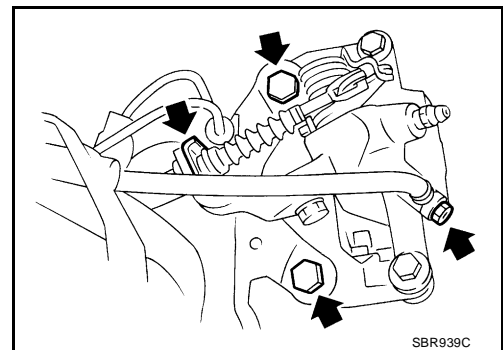

INSTALLATION

1. Install disc rotor.
2. Install brake hose to caliper securely. Tighten connecting bolt to specification. Refer to [BR-29, "Component"](#).

REAR DISC BRAKE

CAUTION:
Install new copper washers.

3. Install caliper assembly.
 - As shown in the figure, align the piston's concave to the pad's convex, then install the cylinder body to the torque member.
4. Install all parts and tighten all bolts to specification. Refer to [BR-29, "Component"](#).
5. Bleed air from brake system. Refer to [BR-7, "Bleeding Brake System"](#).

CAUTION:

- Refill with new brake fluid "DOT 3".
- Never reuse drained brake fluid.

Disassembly and Assembly of Caliper Assembly DISASSEMBLY

1. Remove piston by turning it counterclockwise with suitable commercial service tool or long nose pliers.

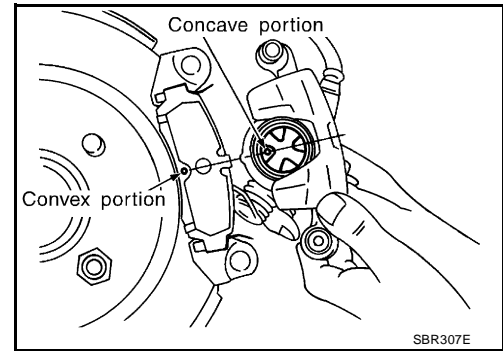

EFS0023P

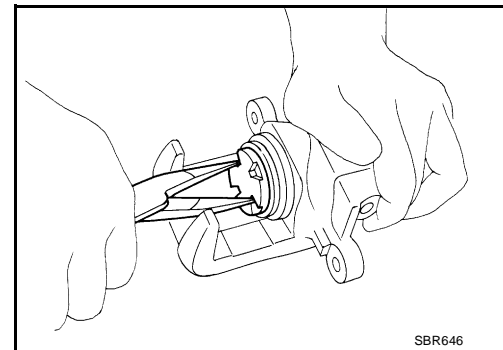
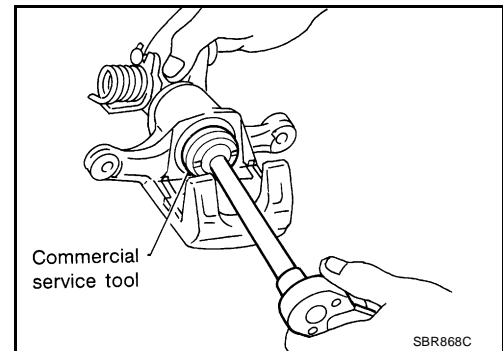

2. Pry off ring A from piston with suitable pliers and remove cup, adjuster, bearing, spacers, and wave washer.

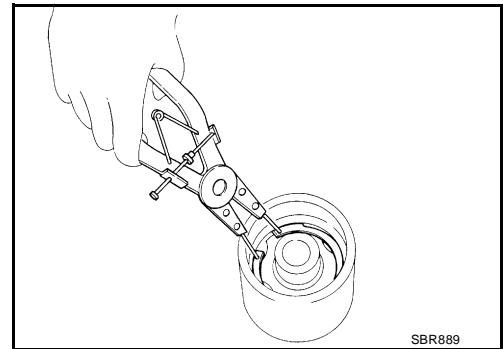

REAR DISC BRAKE

3. Disassemble cylinder body.
 - a. Pry off ring B with suitable pliers, then remove spring cover, spring and seat.
 - b. Pry off ring C, then remove key plate, push rod and rod.

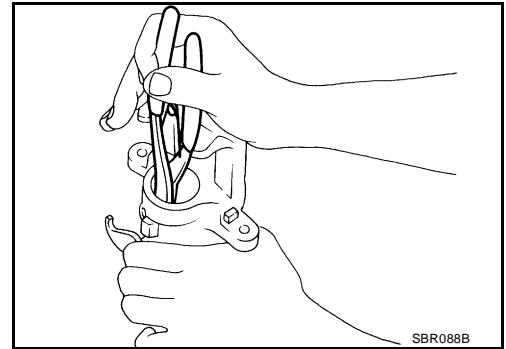

- c. Remove piston seal with a suitable tool.
CAUTION:
Be careful not to damage cylinder body.

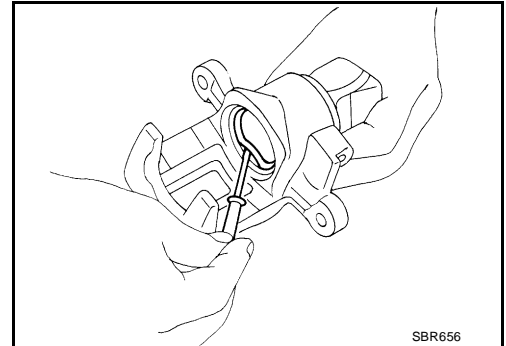

4. Remove return spring, toggle lever and cable guide.

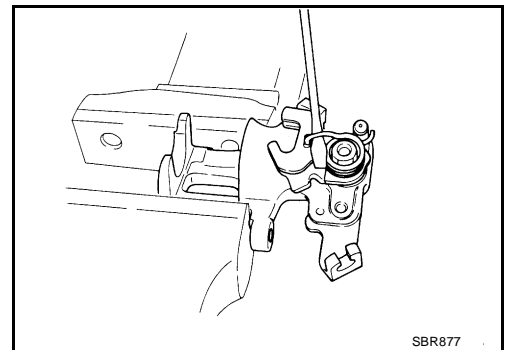

CALIPER INSPECTION

CAUTION:
Use brake fluid to clean cylinder. Never use mineral oil.

Cylinder Body

- Check inside surface of cylinder for score, rust, wear, damage or presence of foreign materials. If any of the above conditions are observed, replace cylinder body.
- Minor damage from rust or foreign materials may be eliminated by polishing surface with a fine emery paper.
- Replace cylinder body if necessary.

Torque Member

Check for wear, cracks or other damage. Replace if necessary.

Piston

CAUTION:
Piston sliding surface is plated. Do not polish with emery paper even if rust or foreign matter is stuck to sliding surface.

Check piston for score, rust, wear, damage or presence of foreign materials.
Replace if any of the above conditions are observed.

Pin and Pin Boot

Check for wear, cracks or other damage.
Replace if any of the above conditions are observed.

REAR DISC BRAKE

DISC ROTOR INSPECTION

Rubbing Surface

Check rotor for roughness, cracks or chips.

Runout

1. Secure rotor to wheel hub with two nuts (M12 x 1.25).
2. Check runout using a dial indicator.

CAUTION:

Make sure that axial end play is within the specifications before measuring. Refer to [RAX-5, "Rear Wheel Bearing"](#).

3. Change relative positions of rotor and wheel hub so that runout is minimized.

Maximum runout : 0.07 mm (0.0028 in)

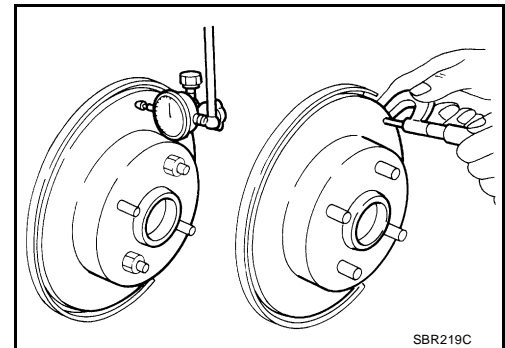

Thickness

Rotor repair limit

Standard thickness : 9 mm (0.35 in)

Standard thickness (with Spec V brake package) : 7 mm (0.28 in)

Minimum thickness : 8 mm (0.31 in)

Minimum thickness (with Spec V brake package) : 6 mm (0.24 in)

**Maximum thickness variation : 0.02 mm (0.0008 in)
(At least 8 portions)**

ASSEMBLY

1. Insert cam with depression facing toward open end of cylinder.

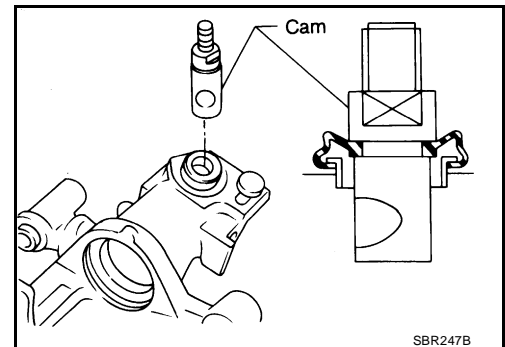

2. Generously apply rubber grease to strut and push rod to make insertion easy.

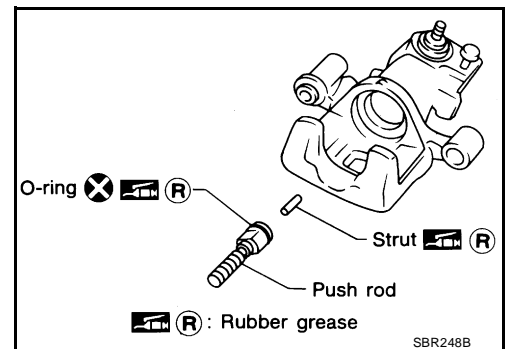

REAR DISC BRAKE

- Fit push rod into square hole in key plate. Also match convex portion of key plate with concave portion of cylinder.

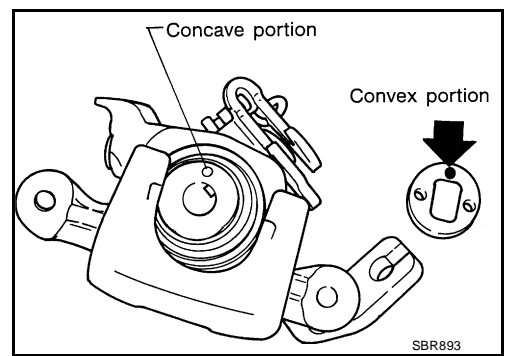

- Install ring C with a suitable tool.

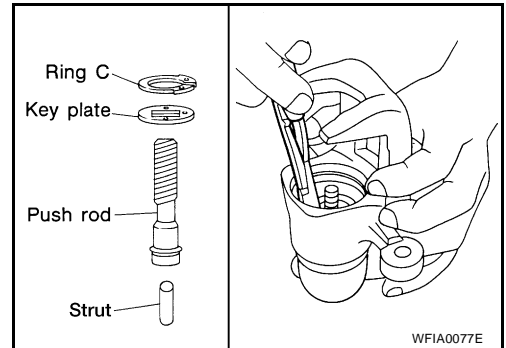

- Install seat, spring, spring cover and ring B with snap ring pliers and a suitable press and drift.

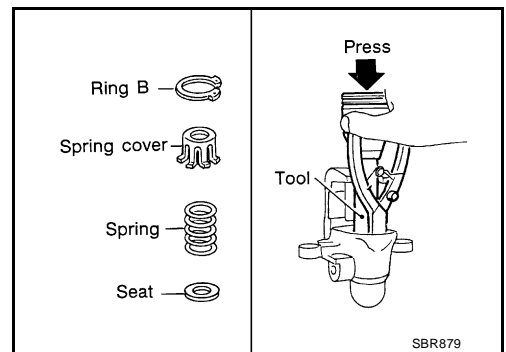
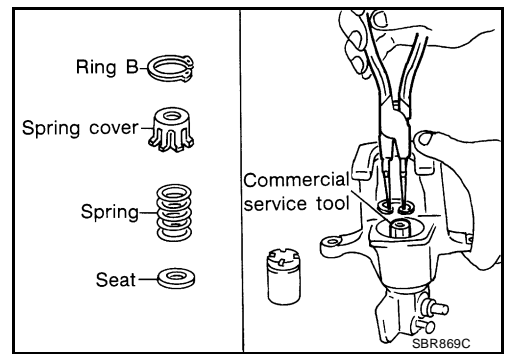

- Install cup in the specified direction.

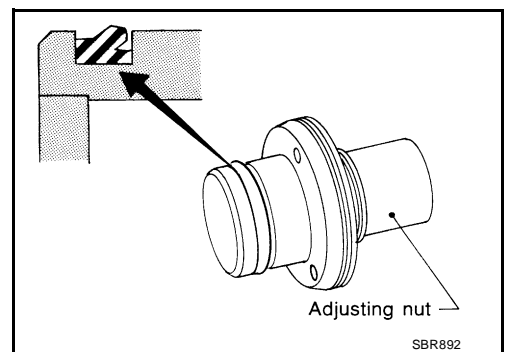

A
B
C
D
E
BR
G
H
I
J
K
L
M

REAR DISC BRAKE

7. Install cup, adjuster, bearing, spacers, washer and ring A with a suitable tool.
8. Insert piston seal into groove on cylinder body.

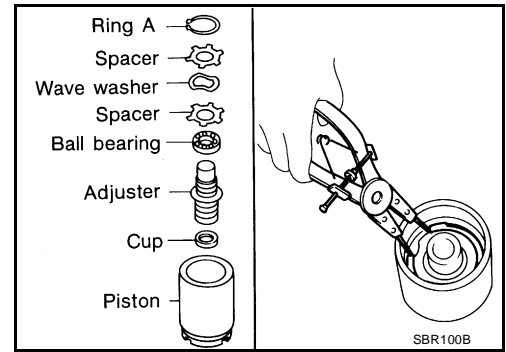

9. With piston boot fitted to piston, insert piston boot into groove on cylinder body and fit piston by turning it clockwise with long nose pliers, or suitable commercial service tool.

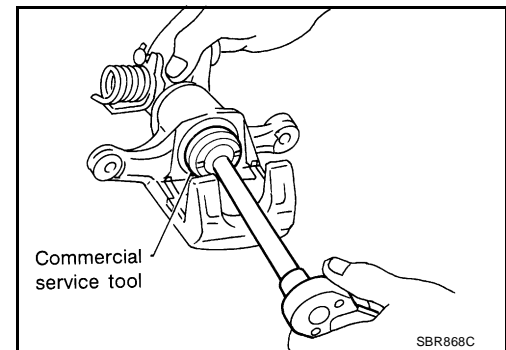
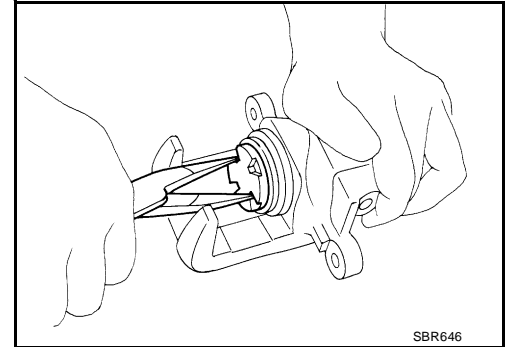

10. Install toggle lever, return spring and cable guide.

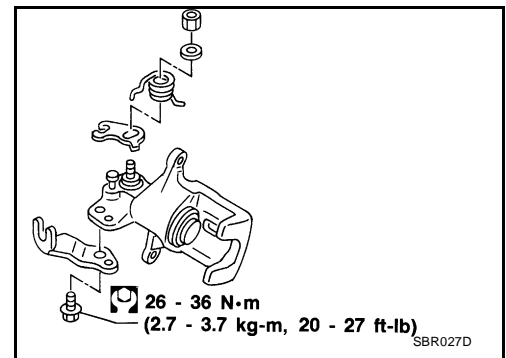

REAR DISC BRAKE

11. Adjust the piston to the right angle as shown.

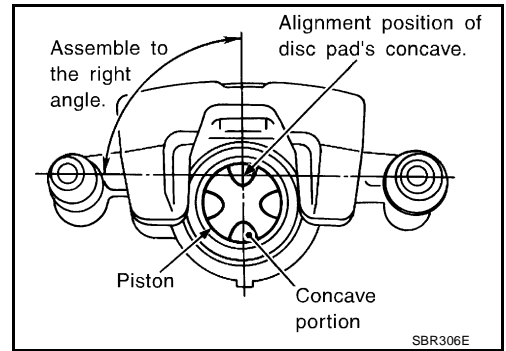

A

B

C

D

E

BR

G

H

I

J

K

L

M

REAR DRUM BRAKE

REAR DRUM BRAKE

PFP:43206

Components

EFS0023T

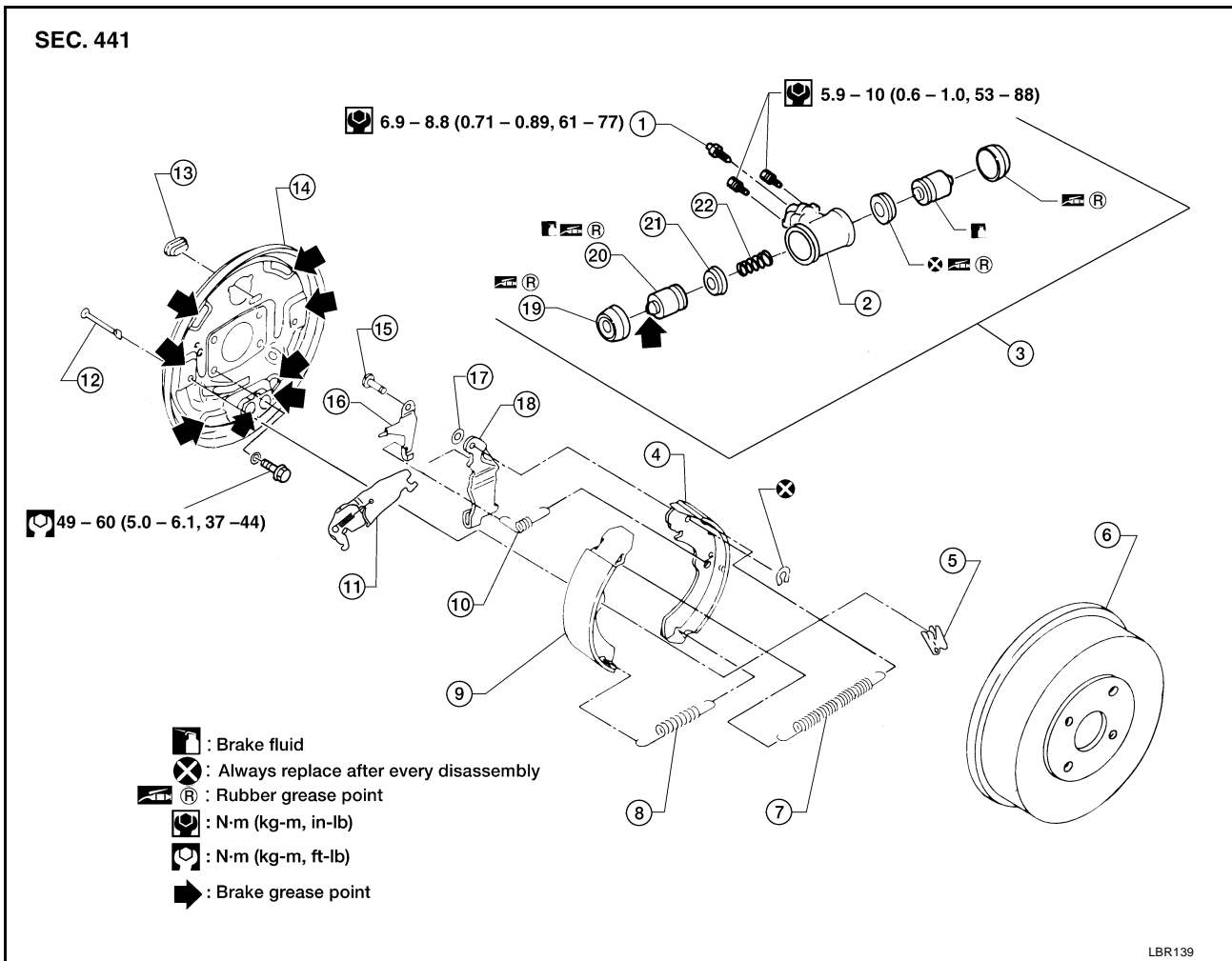

- | | | |
|----------------------|--------------------------|------------------------|
| 1. Air bleeder valve | 2. Cylinder body | 3. Wheel cylinder |
| 4. Shoe | 5. Shoe hold-down spring | 6. Brake drum |
| 7. Return spring | 8. Return spring | 9. Shoe |
| 10. Adjuster spring | 11. Adjuster | 12. Shoe hold-down pin |
| 13. Adjuster plug | 14. Back plate | 15. Retainer |
| 16. Adjusting lever | 17. Washer | 18. Toggle lever |
| 19. Dust cover | 20. Piston | 21. Piston cap |
| 22. Spring | | |

Removal

EFS0023U

WARNING:

Clean brake lining with a vacuum dust collector to minimize the hazard of airborne materials or other materials.

CAUTION:

Make sure parking brake lever is completely released.

1. Remove wheel and tire. Refer to [MA-34, "Tire Rotation"](#).

REAR DRUM BRAKE

2. Release parking brake lever fully, then remove drum.
 - If drum is hard to remove, remove adjuster plug. Shorten adjuster as shown to make clearance between brake shoe and drum. Install two bolts as shown. Tighten the two bolts gradually.

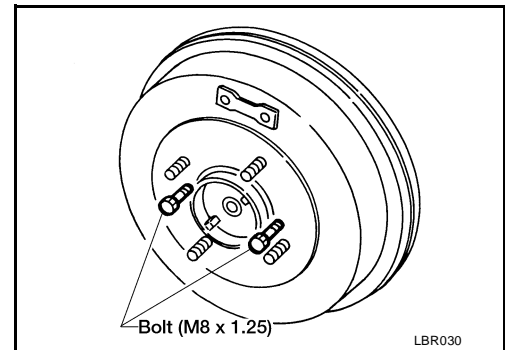
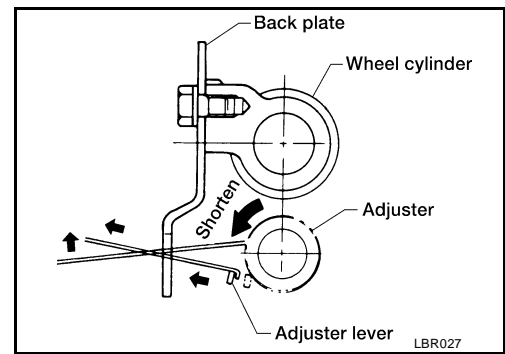

3. After removing retainer, remove spring by rotating shoes.

NOTE:
Be careful not to damage parking brake cable when separating it.
4. Remove adjuster.
5. Disconnect parking brake cable from toggle lever.

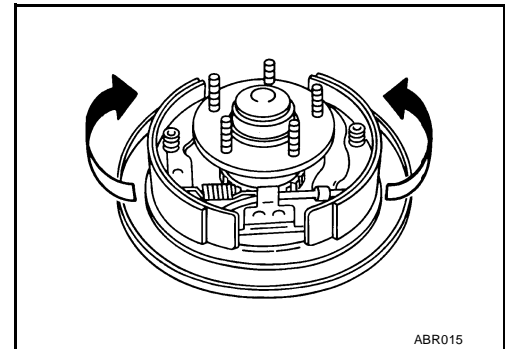

6. Remove retainer ring with a suitable tool. Then separate toggle lever and adjusting lever from the brake shoe.

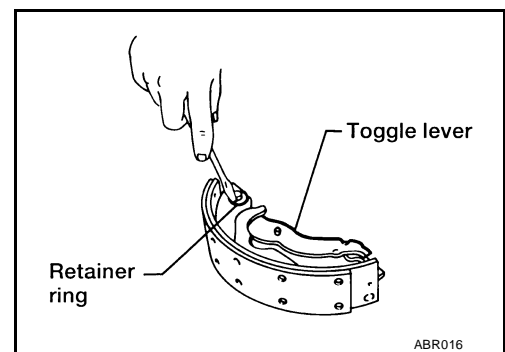

A
B
C
D
E
BR
G
H
I
J
K
L
M

REAR DRUM BRAKE

EFS0023V

Inspection WHEEL CYLINDER

- Check wheel cylinder for leakage.
- Check for wear, damage and loose conditions. Replace if any such condition exists.

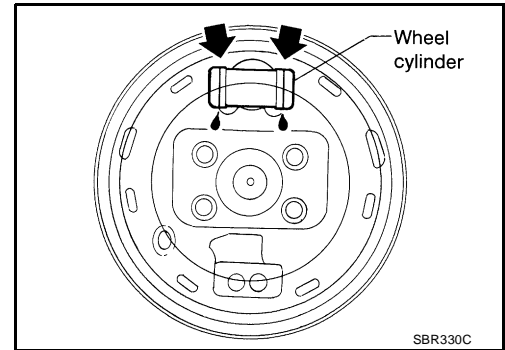

WHEEL CYLINDER OVERHAUL

- Check all internal parts for wear, rust and damage. Replace if necessary.
- Be careful not to scratch cylinder body when installing pistons.

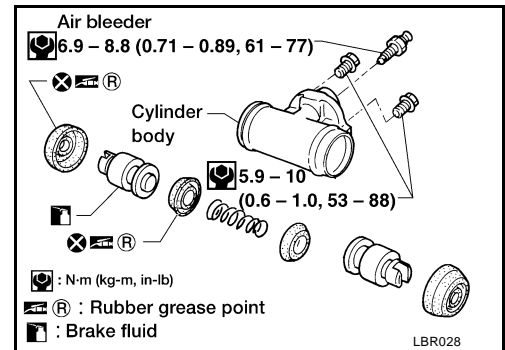

DRUM

Maximum inner diameter : 204.5 mm (8.05 in)

Out-of-roundness : 0.03 mm (0.0012 in) or less

- Contact surface should be fine finished with No. 120 to 150 emery paper.
- Using a drum lathe, resurface brake drum if it shows score, partial wear or stepped wear.
- After brake drum has been completely reconditioned or replaced, check drum and shoes for proper contact pattern.

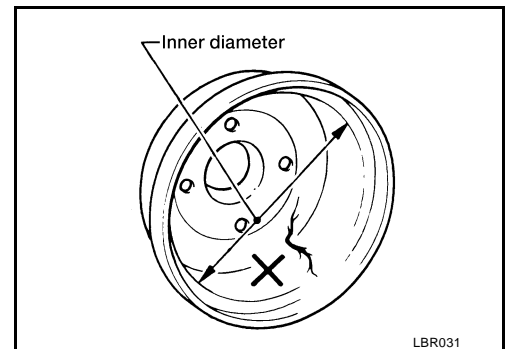

LINING

Check lining thickness.

Standard lining thickness : 4.5 mm (0.177 in)

Lining wear limit : 1.5 mm (0.059 in)

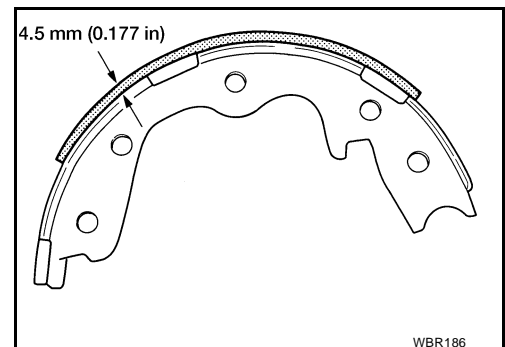

REAR DRUM BRAKE

EFS0023W

Installation

- Always perform shoe clearance adjustment. Refer to [PB-3, "Adjustment"](#) .
 - Burnish the brake contact surfaces after refinishing or replacing drums, after replacing linings, or if a soft pedal occurs at very low mileage. Refer to [BR-7, "Brake Burnishing Procedure"](#) .
1. Fit toggle lever and adjusting lever to brake shoe with retainer ring.
 2. Apply brake grease to the contact areas shown.

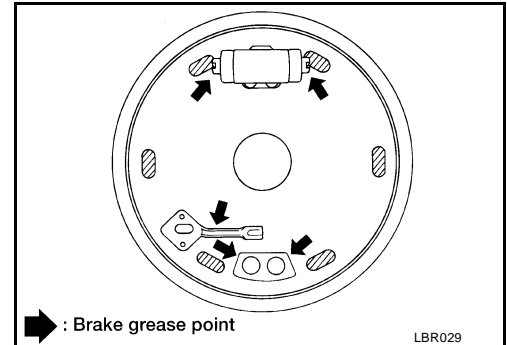

3. Shorten adjuster by rotating it.
 - Pay attention to direction of adjuster.

Wheel	Screw
Left	Left-hand thread
Right	Right-hand thread

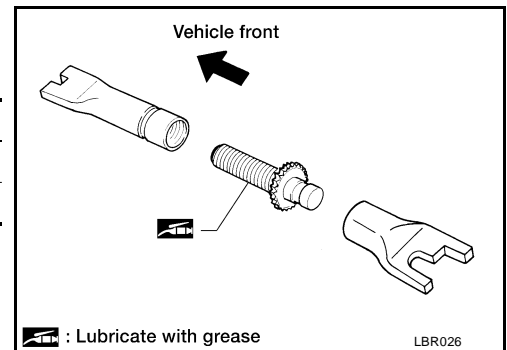

4. Connect parking brake cable to toggle lever.
5. Install all parts.

CAUTION:
Be careful not to damage wheel cylinder piston boots.

6. Check that all parts are installed properly.

CAUTION:
Pay attention to direction of adjuster assembly.

7. Install brake drum.
8. When installing new wheel cylinder or overhauling wheel cylinder, bleed air from brake system. Refer to [BR-7, "Bleeding Brake System"](#) .
9. Adjust parking brake. Refer to [PB-3, "Adjustment"](#) .
10. Install wheel and tire. Refer to [MA-34, "Tire Rotation"](#) .

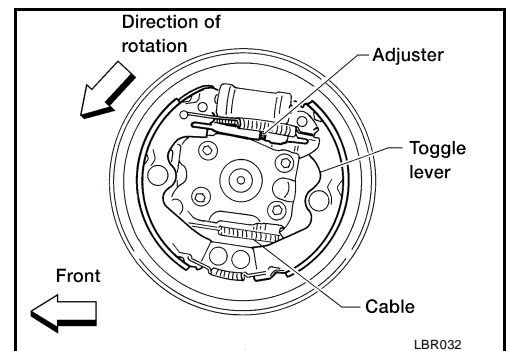

SERVICE DATA AND SPECIFICATIONS (SDS)

SERVICE DATA AND SPECIFICATIONS (SDS)

PFP:00030

General Specifications

EFS0023X

Unit: mm (in)

Applied Model		QG18DE	QR25DE	
Front brake	Brake model	CL25VA	CL25VB	OPB27VA
	Cylinder bore diameter	57.2 (2.252)		38 (1.50) × 2 + 44 (1.73) × 2
	Pad length × width × thickness	125.6 × 46.0 × 11.0 (4.94 × 1.811 × 0.433)		117.1 × 53.3 × 9.3 (4.61 × 2.098 × 0.366)
	Rotor outer diameter × thickness	257 × 22 (10.12 × 0.87)	280 × 22 (11.02 × 0.87)	305 × 22 (12.01 × 0.87)
Rear brake	Brake model	LT20G	CL9HC	
	Cylinder bore diameter/caliper bore diameter	15.87 (5/8) type a 17.45 (11/16) type b	33.96 (1 11/32)	
	Lining length × width × thickness	219.4 × 35 × 4.5 (8.64 × 1.38 × 0.177)	89.1 × 39.5 × 10 (3.508 × 1.555 × 0.39)	
	Drum inner diameter/Disc diameter × thickness	203.2 (8)	232 × 7 (9.13 × 0.28)	232 × 7 (9.13 × 0.28) or 278 × 9 (10.94 × 0.35)*
Master cylinder	Cylinder bore diameter	23.81 (15/16)		
Control valve	Valve model	Dual proportioning valve		
	Split point [kPa (kg/cm ² , psi)] × reducing ratio	1,961 (20,284) × 0.2	2,942 (30,427) × 0.2	
Brake booster	Booster model	M215T		
	Diaphragm diameter	Primary: 230 (9.06) Secondary: 205 (8.07)		
Brake fluid	Recommended brake fluid	Refer to MA-13, "RECOMMENDED FLUIDS AND LUBRICANTS" .		

*: With Spec V brake package.

Brake Pedal

EFS00240

Unit: mm (in)

Free height "H"	M/T	156 - 166 (6.14 - 6.54)
	A/T	164.9 - 174.9 (6.49 - 6.89)
Depressed height "D" [under force of 490 N (50 kg, 110 lb) with engine running]		90 (3.54)
Pedal free play "A"		1.0 - 3.0 (0.039 - 0.118)

*: Measured from surface of dash reinforcement panel.

Front Disc Brake

EFS0023Y

Unit: mm (in)

Brake model	CL25VA/CL25VB	OPB27VA
Pad wear limit Minimum thickness	2.0 (0.079)	2.0 (0.079)
Rotor repair limit Minimum thickness	20 (0.79)	20 (0.79)

SERVICE DATA AND SPECIFICATIONS (SDS)

Rear Disc Brake

EFS00320

Unit: mm (in)

Brake model	CL9HC
Pad wear limit Minimum thickness	2.0 (0.079)
Rotor repair limit Minimum thickness	8.0 (0.31) or 6.0 (0.24)*

*: With Spec V brake package.

Drum Brake

EFS0023Z

Unit: mm (in)

Brake model	LT20G	
Lining wear limit	Minimum thickness	1.5 (0.059)
	Maximum inner diameter	204.5 (8.05)
Drum repair limit	Maximum out-of round	0.03 (0.0012)

A
B
C
D
E
G
H
I
J
K
L
M

BR

SERVICE DATA AND SPECIFICATIONS (SDS)
