

SECTION **BR**
BRAKE SYSTEM

A
B
C
D
E

CONTENTS

SERVICE INFORMATION	2	VACUUM LINES	20
PRECAUTIONS	2	Component	20
Precaution for Supplemental Restraint System (SRS) "AIR BAG" and "SEAT BELT PRE-TENSIONER"	2	Removal and Installation	20
Precaution for Brake System	2	Inspection	20
PREPARATION	3	FRONT DISC BRAKE	22
Special Service Tool	3	On Board Inspection	22
Commercial Service Tool	3	Component	22
NOISE, VIBRATION AND HARSHNESS (NVH) TROUBLESHOOTING	4	Removal and Installation of Brake Pad	23
NVH Troubleshooting Chart	4	Removal and Installation of Brake Caliper Assembly	24
BRAKE PEDAL	5	Disassembly and Assembly of Brake Caliper Assembly	24
Inspection and Adjustment	5	Brake Burnishing	27
Removal and Installation	6	REAR DISC BRAKE	28
BRAKE FLUID	8	On Board Inspection	28
On Board Inspection	8	Component	28
Drain and Refill	8	Removal and Installation of Brake Pad	29
Bleeding Brake System	8	Removal and Installation of Caliper Assembly	29
BRAKE TUBE AND HOSE	10	Disassembly and Assembly of Caliper Assembly	30
Hydraulic Circuit	10	Brake Burnishing	33
Front Brake Tube and Hose	11	REAR DRUM BRAKE	34
Rear Brake Tube and Hose	11	Component	34
Inspection After Installation	12	Removal and Installation of Drum Brake Assembly	34
DUAL PROPORTIONING VALVE	13	Removal and Installation of Wheel Cylinder	37
Removal and Installation	13	Disassembly and Assembly of Wheel Cylinder	37
Inspection	13	SERVICE DATA AND SPECIFICATIONS (SDS)	38
BRAKE MASTER CYLINDER	15	General Specification	38
On-Board Inspection	15	Brake Pedal	39
Removal and Installation	15	Check Valve	39
BRAKE BOOSTER	17	Brake Booster	39
On Board Inspection	17	Dual Proportioning Valve	39
Removal and Installation	17	Front Disc Brake	39
		Rear Disc Brake	40
		Rear Drum Brake	40

BR
G
H
I
J
K
L
M
N
O
P

PRECAUTIONS

< SERVICE INFORMATION >

SERVICE INFORMATION

PRECAUTIONS

Precaution for Supplemental Restraint System (SRS) "AIR BAG" and "SEAT BELT PRE-TENSIONER"

INFOID:000000001851295

The Supplemental Restraint System such as "AIR BAG" and "SEAT BELT PRE-TENSIONER", used along with a front seat belt, helps to reduce the risk or severity of injury to the driver and front passenger for certain types of collision. This system includes seat belt switch inputs and dual stage front air bag modules. The SRS system uses the seat belt switches to determine the front air bag deployment, and may only deploy one front air bag, depending on the severity of a collision and whether the front occupants are belted or unbelted. Information necessary to service the system safely is included in the SRS and SB section of this Service Manual.

WARNING:

- To avoid rendering the SRS inoperative, which could increase the risk of personal injury or death in the event of a collision which would result in air bag inflation, all maintenance must be performed by an authorized NISSAN/INFINITI dealer.
- Improper maintenance, including incorrect removal and installation of the SRS, can lead to personal injury caused by unintentional activation of the system. For removal of Spiral Cable and Air Bag Module, see the SRS section.
- Do not use electrical test equipment on any circuit related to the SRS unless instructed to in this Service Manual. SRS wiring harnesses can be identified by yellow and/or orange harnesses or harness connectors.

Precaution for Brake System

INFOID:000000001851296

- Refill using recommended brake fluid. Refer to [MA-13](#).
- Never reuse drained brake fluid.
- Be careful not to splash brake fluid on painted surface of body. If brake fluid is splashed on painted surfaces of body immediately wipe it off with cloth and then wash it away with water.
- To clean or wash all parts of master cylinder, disc brake caliper and wheel cylinder, use new brake fluid.
- Never use mineral oils such as gasoline or kerosene. They will ruin rubber parts of the hydraulic system.
- Use a flare nut wrench when removing a brake tube and use a flare nut torque wrench when installing a brake tube.
- When installing brake tubes and hoses, be sure to check torque.
- Before working, turn ignition switch OFF and disconnect connectors of ABS actuator and electric unit (control unit) or the battery cable from the negative terminal.
- Burnish the new braking surfaces after refinishing or replacing drums or rotors, after replacing pads or linings, or if a soft pedal occurs at very low mileage. Refer to [BR-27](#), "Brake Burnishing".

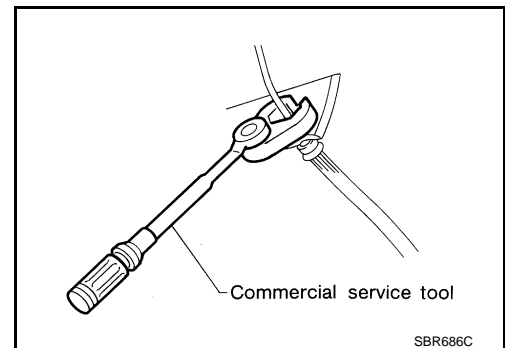

PREPARATION

< SERVICE INFORMATION >

PREPARATION

Special Service Tool

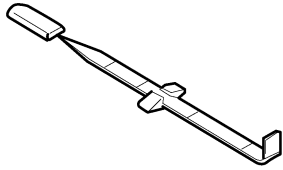

INFOID:000000001851297

The actual shapes of Kent-Moore tools may differ from those of special service tools illustrated here.

Tool number (Kent-Moore No.) Tool name	Description
<p>— (J-46532) Brake and clutch pedal height measurement tool</p>  <p>LFAI0227E</p>	<p>Measuring brake pedal height</p>

Commercial Service Tool

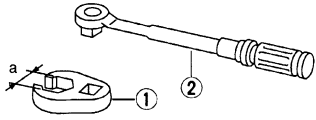
INFOID:000000001851298

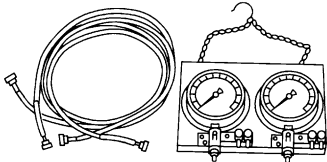
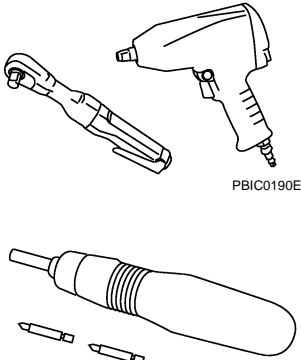
Tool name	Description
<p>1 Flare nut crowfoot 2 Torque wrench</p>  <p>S-NT360</p>	<p>Removing and installing each brake piping a: 10 mm (0.39 in)/12mm (0.47 in)</p>
<p>Pin punch Tip diameter: 4 mm (0.16 in) dia.</p>  <p>ZZA0515D</p>	<p>Removing and installing reservoir tank pin</p>
<p>Brake fluid pressure gauge</p>  <p>NT151</p>	<p>Measuring brake fluid pressure</p>
<p>Power tool</p>  <p>PBIC0190E PBIC0191E</p>	<p>Loosening nuts, bolts, and screws</p>

NOISE, VIBRATION AND HARSHNESS (NVH) TROUBLESHOOTING

< SERVICE INFORMATION >

NOISE, VIBRATION AND HARSHNESS (NVH) TROUBLESHOOTING

NVH Troubleshooting Chart

INFOID:000000001851299

Use the chart below to help you find the cause of the symptom. If necessary, repair or replace these parts.

Symptom		Possible cause and SUSPECTED PARTS													Reference page			
		Pads/Lining damaged	Pads/Lining - uneven wear	Shims damaged	Rotor imbalance	Rotor damage	Rotor runout	Rotor deformation	Rotor deflection	Rotor rust	Rotor thickness variation	Drum out of round	WHEEL HUB	SUSPENSION	TIRES	ROAD WHEEL	DRIVE SHAFT	STEERING
Symptom	Noise	x	x	x									x	x	x	x	x	x
	Shake				x								x	x	x	x	x	x
	Shimmy, Shudder				x	x	x	x	x	x	x	x		x	x	x		x

x: Applicable

BRAKE PEDAL

< SERVICE INFORMATION >

BRAKE PEDAL

Inspection and Adjustment

INFOID:000000001851300

PLAY AND CLEARANCE BETWEEN BRAKE PEDAL AND FLOOR PANEL WITH PEDAL DE-PRESSED

- Check brake pedal play.
- Check brake pedal initial height "H1" from dash lower panel (1) using Tool.

Tool : — (J-46532)

- Make an adjustment to the following dimension if value is outside the standard. Refer to [BR-5, "Inspection and Adjustment"](#).

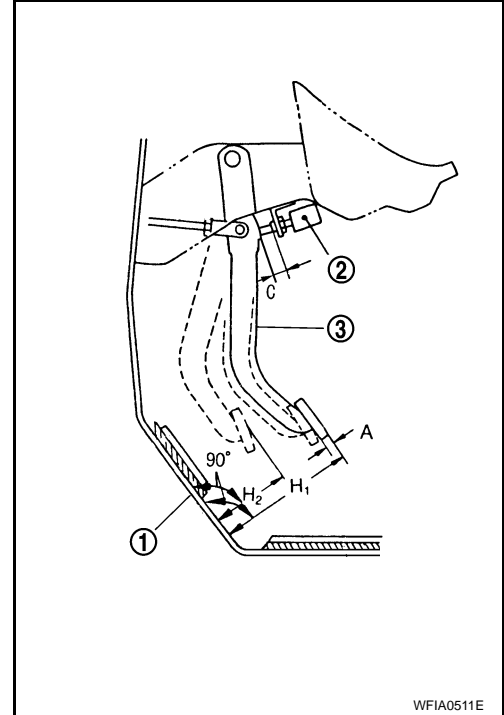

H1	Brake pedal initial height (from dash panel top surface)	164.0 - 174.0 mm (6.45 - 6.85 in)
H2	Brake pedal depressed height (under a force of 490 N (50 kg-f, 110 lb-f) with the engine running)	—
C	Clearance between the threaded end of stop lamp switch or ASCD switch, if equipped (2) and brake pedal lever (3).	0.74 - 1.96 mm (0.0291 - 0.0772 in)
A	Pedal play	3 - 11 mm (0.12 - 0.43 in)

ADJUSTMENT

BRAKE PEDAL

< SERVICE INFORMATION >

1. Loosen stop lamp switch and ASCD switch (if equipped) by rotating it counterclockwise by 45°.
2. Loosen lock nut on input rod, then rotate input rod to set pedal to the specified height, and tighten lock nut.

CAUTION:

Make sure that the threaded end of input rod stays inside clevis.

Lock nut : Refer to [BR-6, "Removal and Installation"](#).

3. With the pedal pulled and held by hand, press stop lamp switch or ASCD switch (if equipped) until its threaded end contacts brake pedal lever.
4. With the threaded end of stop lamp switch or ASCD switch (if equipped) contacting brake pedal lever, rotate the switch clockwise by 45° to secure.

CAUTION:

Make sure that the clearance (C) is within the standard. Refer to [BR-39, "Brake Pedal"](#).

5. Check the pedal play.

CAUTION:

Make sure that stop lamps go off when brake pedal is released.

6. Start engine to check brake pedal depressed height. Refer to [BR-39, "Brake Pedal"](#).

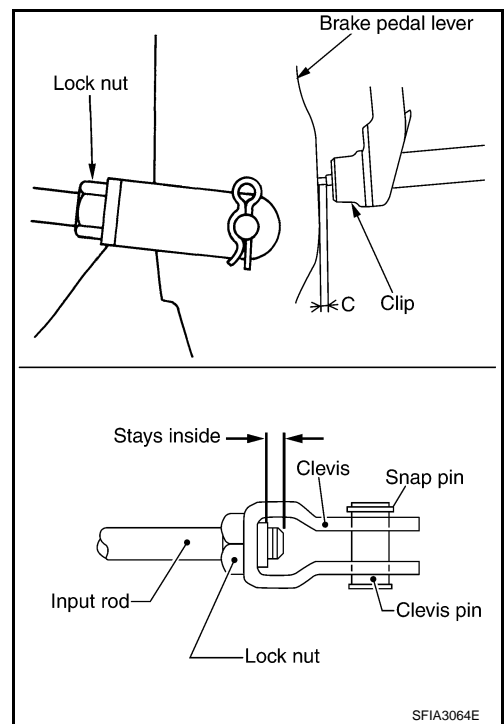

SFIA3064E

Removal and Installation

INFOID:000000001851301

COMPONENTS

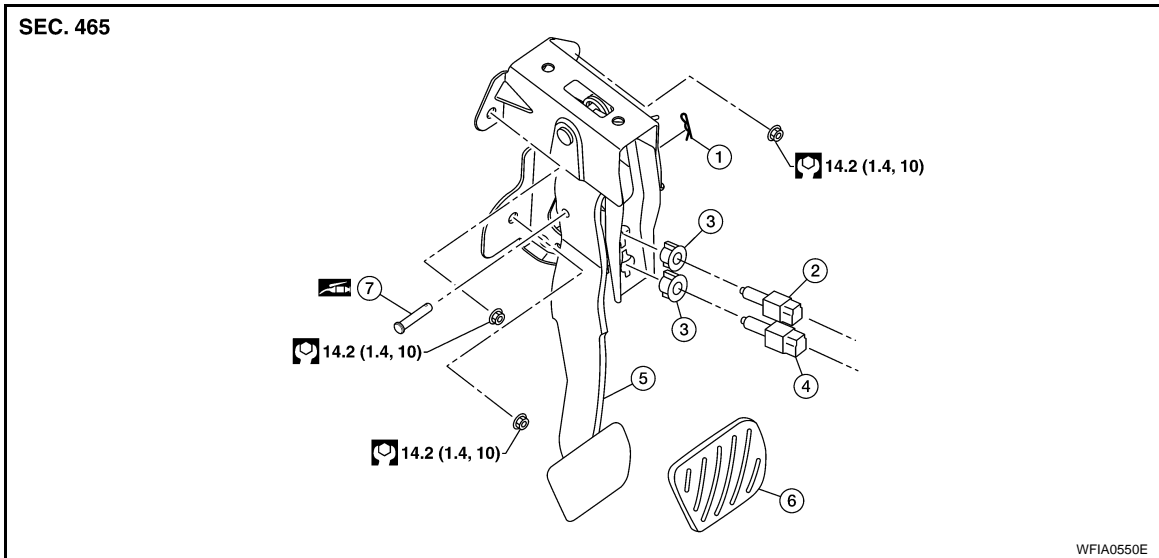

WFIA0550E

- | | | |
|---------------------|-------------------------|--------------------|
| 1. Snap pin | 2. ASCD switch | 3. Clip |
| 4. Stop lamp switch | 5. Brake pedal assembly | 6. Brake pedal pad |
| 7. Clevis | | |

REMOVAL

BRAKE PEDAL

< SERVICE INFORMATION >

1. Disconnect accelerator pedal position sensor harness connector.
2. Remove stop lamp switch and ASCD switch (if equipped) from brake pedal assembly.
3. Remove snap pin and clevis pin from clevis of brake booster.
4. Remove nuts from brake pedal bracket, and remove brake pedal assembly from vehicle.
5. Remove accelerator pedal from brake pedal assembly.

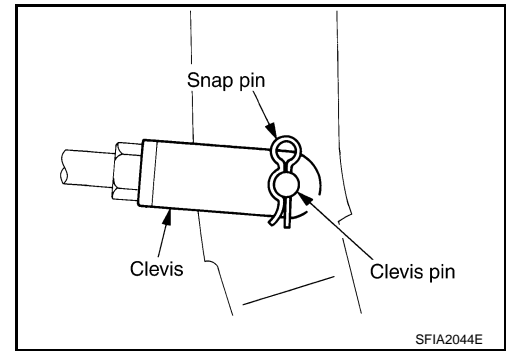

INSPECTION AFTER REMOVAL

- Check brake pedal for bend, damage, and cracks on the welded parts.
- Replace brake pedal assembly if any non-standard condition is detected.
- Check clevis pin and plastic stopper for damage and deformation. Replace clevis pin as necessary.

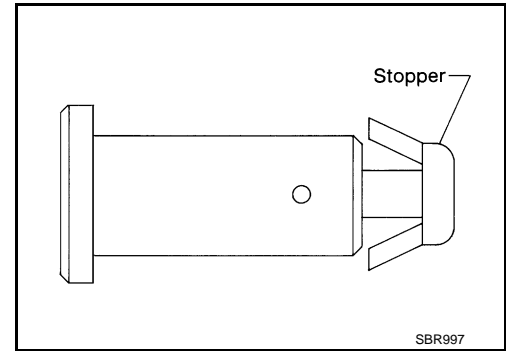

INSTALLATION

Installation is in the reverse order of the removal.

- After installing brake pedal assembly to vehicle, adjust brake pedal. Refer to [BR-5, "Inspection and Adjustment"](#).
- After installing accelerator pedal, check accelerator pedal. Refer to [ACC-3, "Accelerator Control"](#).

BRAKE FLUID

< SERVICE INFORMATION >

BRAKE FLUID

On Board Inspection

INFOID:000000001851302

CHECKING BRAKE FLUID LEVEL

- Make sure the fluid level in the reservoir tank is within the standard (between MAX and MIN lines). Refer to [MA-39, "Checking Brake Fluid Level and Leaks"](#).
- Visually check around the reservoir tank for fluid leakage.
- If fluid level is excessively low, check brake system for fluid leakage.
- Release parking brake lever and see if brake warning lamp goes off. If not, check brake system for fluid leakage.

Drain and Refill

INFOID:000000001851303

CAUTION:

- Refill using recommended brake fluid. Refer to [MA-13](#).
- Never reuse drained brake fluid.
- Be careful not to splash brake fluid on painted areas; it may cause paint damage. If brake fluid is splashed on painted areas, immediately wipe them with cloth and wash it away with water.
- Before working, disconnect connectors of ABS actuator and electric unit (control unit) or battery cable from the negative terminal.

1. Connect a vinyl tube to bleed valve.
2. Depress the brake pedal, loosen the bleed valve, and gradually remove the brake fluid.

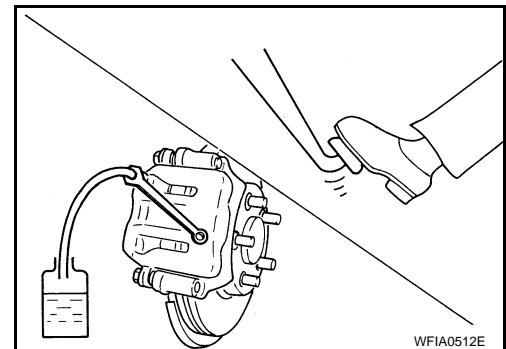

3. Clean inside of reservoir tank, and refill with new brake fluid.
4. Loosen bleed valve, depress brake pedal slowly to full stroke and then release it. Repeat the procedure every 2 or 3 seconds until the new brake fluid comes out, then close the bleed valve while depressing the brake pedal. Repeat the same procedure for each wheel.

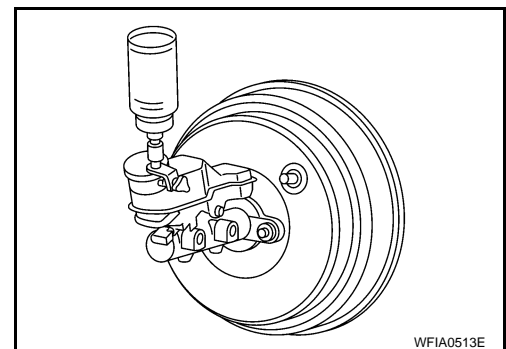

5. Bleed air. Refer to [BR-8, "Bleeding Brake System"](#).

Bleeding Brake System

INFOID:000000001851304

CAUTION:

- While bleeding, pay attention to master cylinder fluid level.
- Before working, disconnect connectors of ABS actuator and electric unit (control unit) or the battery cable from the negative terminal.

1. Connect a vinyl tube to the rear right bleed valve.
2. Fully depress brake pedal 4 to 5 times.
3. With brake pedal depressed, loosen bleed valve to let the air out, and then tighten it immediately.
4. Repeat steps 2, 3 until no more air comes out.
5. Tighten bleed valve to specified torque. Refer to [BR-22, "Component"](#) (front disc brake), [BR-34, "Component"](#) (rear drum brake).

BRAKE FLUID

< SERVICE INFORMATION >

6. Following the steps 1 to 5 above, with master cylinder reservoir tank filled at least half way, bleed air from the rear right, front left, rear left, and front right brake, in that order.

A

B

C

D

E

BR

G

H

I

J

K

L

M

N

O

P

BRAKE TUBE AND HOSE

< SERVICE INFORMATION >

BRAKE TUBE AND HOSE

Hydraulic Circuit

INFOID:000000001851305

Without ABS

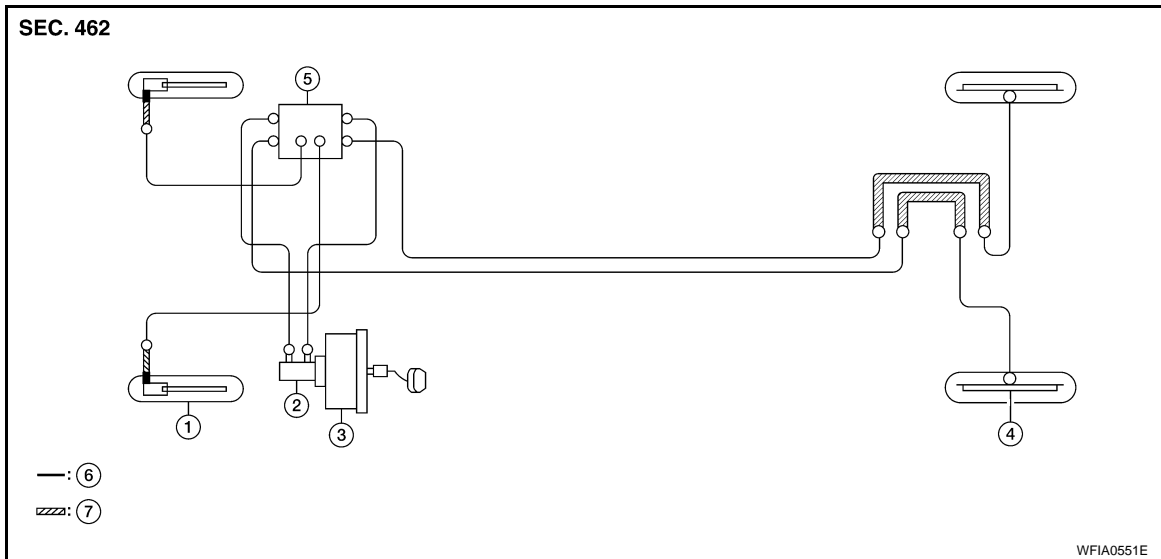

- | | | |
|---------------------|-----------------------------|------------------|
| 1. Front disc brake | 2. Brake master cylinder | 3. Brake booster |
| 4. Rear drum brake | 5. Dual proportioning valve | 6. Brake tube |
| 7. Brake hose | | |

- | | |
|--|---|
| ■: Union bolt
18 N.m (1.8 kg-m, 13 ft-lb) | ○: Flare nut
17 N.m (1.7 kg-m, 12 ft-lb) |
|--|---|

With ABS

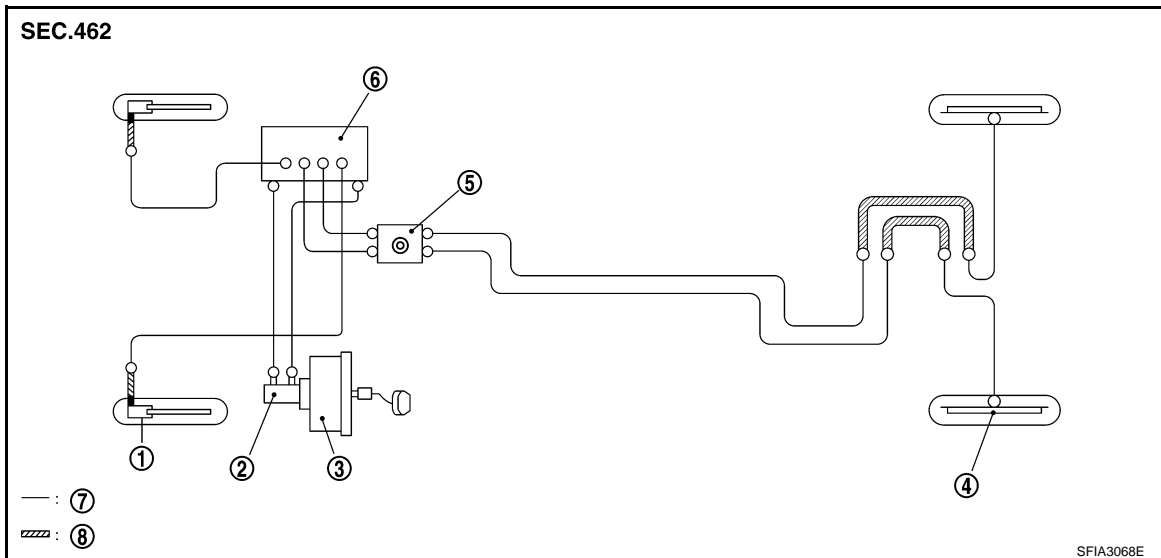

- | | | |
|---------------------|--------------------------|--|
| 1. Front disc brake | 2. Brake master cylinder | 3. Brake booster |
| 4. Rear drum brake | 5. Connector | 6. ABS actuator and electric unit (control unit) |
| 7. Brake tube | 8. Brake hose | |

- | | | |
|--|--|---|
| ■: Union bolt
18 N.m (1.8 kg-m, 13 ft-lb) | ⊙: Connector bolt
10.0 N.m (1.0 kg-m, 87.0 in-lb) | ○: Flare nut
17 N.m (1.7 kg-m, 12 ft-lb) |
|--|--|---|

CAUTION:

- All tubes and hoses must be free from excessive bending, twisting and pulling.

BRAKE TUBE AND HOSE

< SERVICE INFORMATION >

- Make sure there is no interference with other parts when turning steering both clockwise and counterclockwise.
- Brake tubes and hoses are an important safety part. Always disassemble the parts and retighten their fittings, if a brake fluid leak is detected. Replace applicable part with a new one, if damaged part is detected.
- Be careful not to splash brake fluid on painted areas; it may cause paint damage. If brake fluid is splashed on painted surfaces of body, immediately wipe them with cloth and then wash it away with water.
- Do not bend or twist brake hose sharply, or strongly pull it.
- When removing components, cover brake line connections so that dirt, dust, or other foreign matters do not get in.
- Refill using recommended brake fluid. Refer to [MA-13](#).
- Never reuse drained brake fluid.

Front Brake Tube and Hose

INFOID:000000001851306

REMOVAL

1. Drain brake fluid. Refer to [BR-8, "Drain and Refill"](#).
2. Remove brake tube from brake hose, using suitable tool.
3. Remove union bolt, and remove brake hose from caliper assembly.
4. Remove lock plate, and remove brake hose from vehicle.

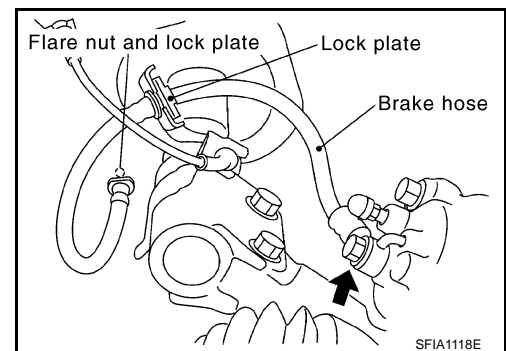

INSTALLATION

1. Assemble union bolt and copper washers to brake hose.
2. Position the L-shape metal fitting of the brake hose to the brake caliper assembly positioning hole.
3. Tighten union bolt to the specified torque. Refer to [BR-10, "Hydraulic Circuit"](#).
4. Connect brake hose to brake tube on vehicle, and temporarily tighten flare nut by hand as much as possible.
5. Secure it with lock plate.
6. Tighten flare nut to the specified torque using suitable tool. Refer to [BR-10, "Hydraulic Circuit"](#).
7. Install brake hose to vehicle, and tighten nuts to the specified torque.
8. Bleed air from brake system. Refer to [BR-8, "Bleeding Brake System"](#).

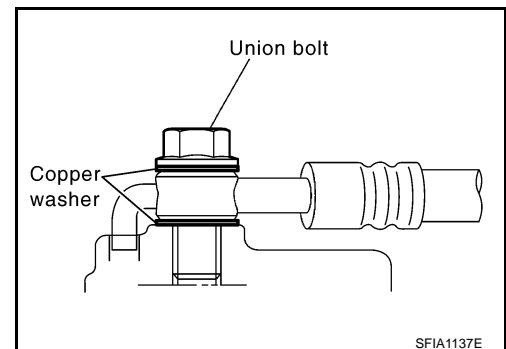

Rear Brake Tube and Hose

INFOID:000000001851307

REMOVAL

1. Drain brake fluid. Refer to [BR-8, "Drain and Refill"](#).
2. Remove brake tube from brake hose, using a suitable tool.
3. Remove lock plate, and remove brake hose from vehicle.

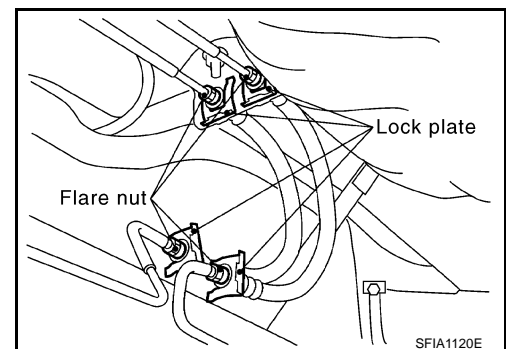

BRAKE TUBE AND HOSE

< SERVICE INFORMATION >

INSTALLATION

1. Connect brake hose to brake tube on vehicle, and temporarily tighten flare nut by hand as much as possible.
2. Secure it to bracket with lock plate.
3. Tighten flare nut to the specified torque using a suitable tool. Refer to [BR-10. "Hydraulic Circuit"](#).
4. Bleed air from brake system. Refer to [BR-8. "Bleeding Brake System"](#).

Inspection After Installation

INFOID:000000001851308

CAUTION:

- Always disassemble the parts and retighten their fittings, if a brake fluid leak is detected. Replace applicable part with a new one, if damaged part is detected.
 - If leak is detected at the connections, retighten it or replace the damaged part.
1. Check brake hose, tube, and connections for fluid leaks, damage, twist, deformation, contact with other parts, and loose connections.
 2. While depressing pedal under a force of 785 N (80 kg-f, 177 lb-f) with the engine running for approximately 5 seconds, check for fluid leak from each part.

DUAL PROPORTIONING VALVE

< SERVICE INFORMATION >

DUAL PROPORTIONING VALVE

Removal and Installation

INFOID:000000001851309

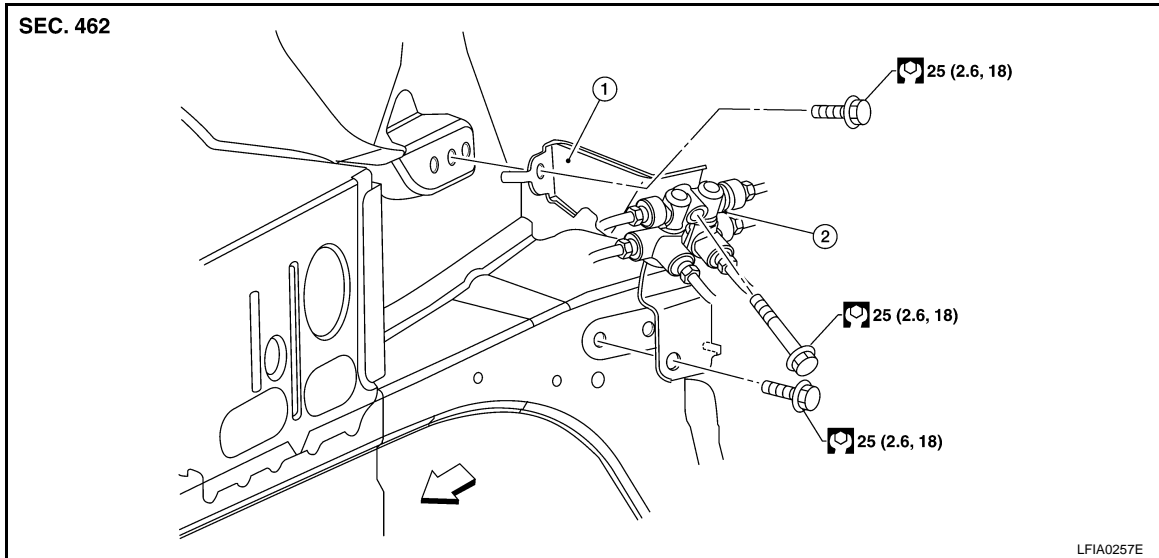

1. Bracket

2. Dual proportioning valve

← : Front

Removal

1. Disconnect brake lines from dual proportioning valve.
 - Mark brake lines for installation.
2. Remove dual proportioning valve bolt and dual proportioning valve.
3. Remove two bolts and bracket.

Installation

Installation is in the reverse order of removal.

- When installing brake lines to the dual proportioning valve, tighten to specifications. Refer to [BR-10](#), "[Hydraulic Circuit](#)".

Inspection

INFOID:000000001851310

CAUTION:

- Carefully monitor brake fluid level at master cylinder.
- Use the recommended new brake fluid. Refer to [MA-13](#).
- Be careful not to splash brake fluid on painted areas; it may cause paint damage. If brake fluid is splashed on paint areas, wash it away with water immediately.

1. Connect commercially available brake fluid pressure gauge to air bleeders of front and rear brakes on either LH and RH side.
2. Bleed air from the Tool.
3. Check fluid pressure by depressing brake pedal.

Unit: kPa (kg/cm², psi)

Applied pressure (Front brake)	7,355 (75, 1,067)
Output pressure (Rear brake)	5,099 - 5,492 (52 - 56, 740 - 796)

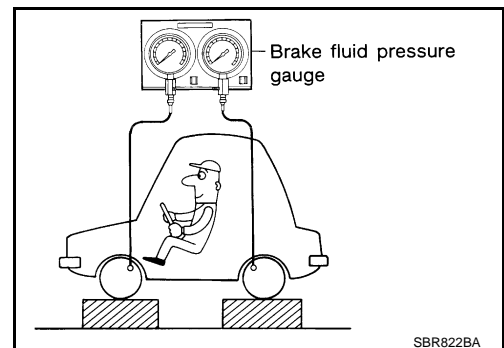

DUAL PROPORTIONING VALVE

< SERVICE INFORMATION >

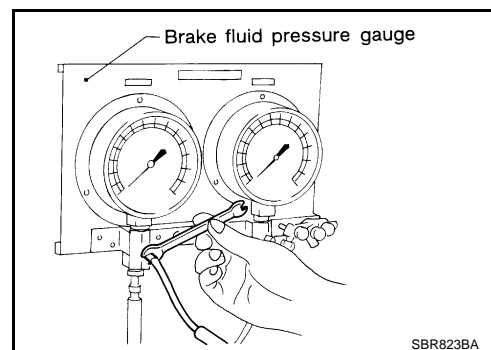

- If output pressure is out of specification, replace dual proportioning valve.
4. Bleed air after disconnecting the Tool. Refer to [BR-8, "Bleeding Brake System"](#).

BRAKE MASTER CYLINDER

< SERVICE INFORMATION >

BRAKE MASTER CYLINDER

On-Board Inspection

INFOID:000000001851311

LEAK INSPECTION

- Check for leaking in a master cylinder installation surface, a reservoir tank installation surface, and brake tube connections.

Removal and Installation

INFOID:000000001851312

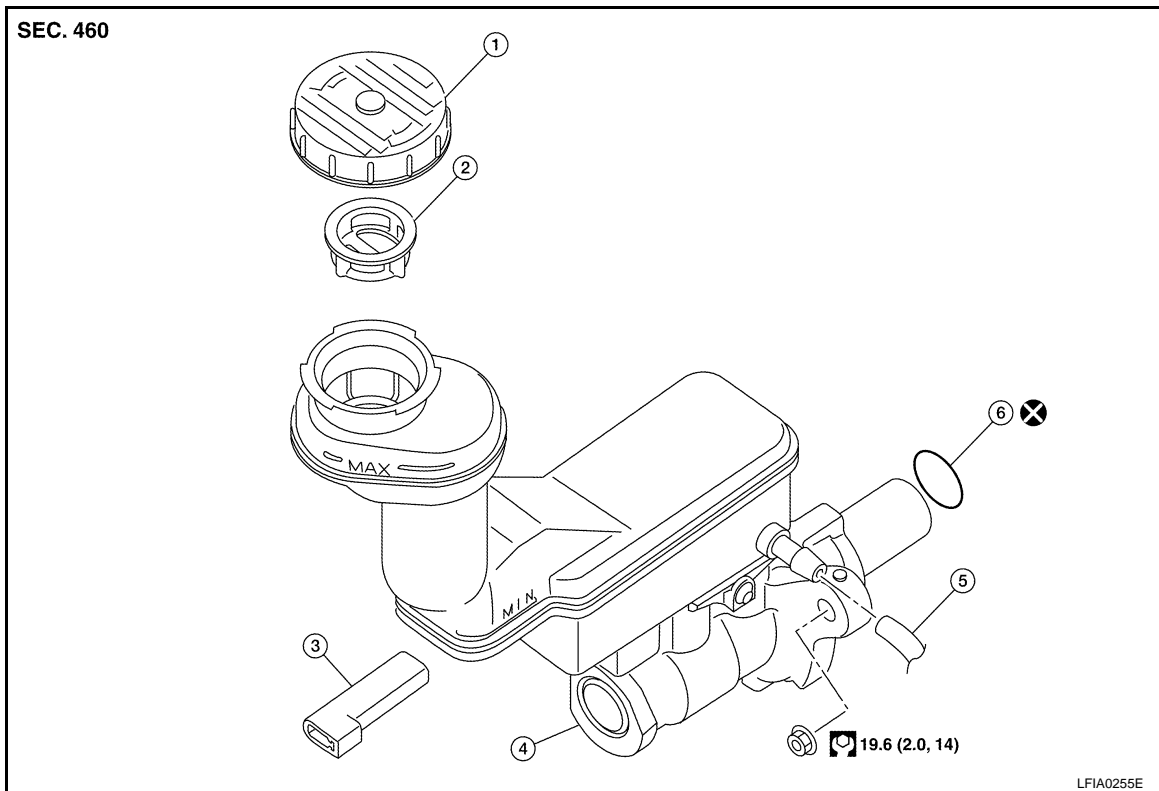

1. Reservoir cap
2. Filter
3. Brake fluid level switch connector
4. Master cylinder and reservoir assembly
5. Hose to clutch master cylinder (if equipped)
6. O-ring

CAUTION:

Be careful not to splash brake fluid on painted areas; it may cause paint damage. If brake fluid is splashed on painted areas, immediately wipe them with cloth and wash it away with water.

REMOVAL

1. Drain brake fluid. Refer to [BR-8, "Drain and Refill"](#).
2. Remove battery.
3. Remove air cleaner and air duct. Refer to [EM-16, "Removal and Installation"](#).
4. Disconnect brake fluid level switch harness connector.
5. Disconnect hose to clutch master cylinder (if equipped) from brake fluid reservoir.
6. Remove brake tube from master cylinder, using a suitable tool.
7. Remove master cylinder assembly nuts, and remove master cylinder assembly.

INSTALLATION

CAUTION:

- Refill using recommended brake fluid. Refer to [MA-13](#).
- Never reuse drained brake fluid.
- Check if the rod of primary piston has dust or scratches.

BRAKE MASTER CYLINDER

< SERVICE INFORMATION >

1. Install master cylinder to brake booster assembly, and tighten nuts to the specified torque.

CAUTION:

- Do not damage or strain rod of primary piston.
- Apply silicone grease for O-ring, primary piston rod and to inside of booster.

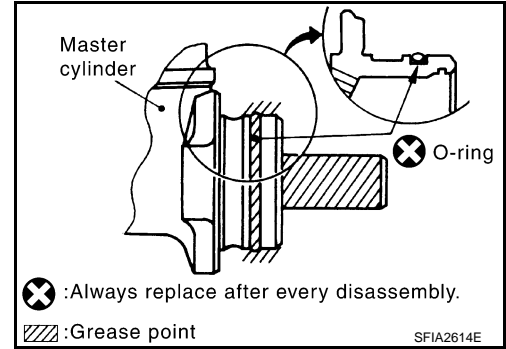

2. Install brake tube to master cylinder, and temporarily tighten the flare nuts on the brake tube to master cylinder by hand.
3. Install brake tube to brake hose, then tighten flare nut to the specified torque using a suitable tool. Refer to [BR-10. "Hydraulic Circuit"](#).
4. Connect brake fluid level switch harness connector and clutch master cylinder hose (if equipped).
5. Refill new brake fluid and bleed air. Refer to [BR-8. "Bleeding Brake System"](#).

BRAKE BOOSTER

< SERVICE INFORMATION >

BRAKE BOOSTER

On Board Inspection

INFOID:000000001851313

OPERATING CHECK

With the engine stopped, change the vacuum to the atmospheric pressure by depressing brake pedal several times at intervals of 5 seconds.

Then with brake pedal fully depressed, start engine and when the vacuum pressure reaches the standard, make sure that the clearance between brake pedal and floor panel decreases.

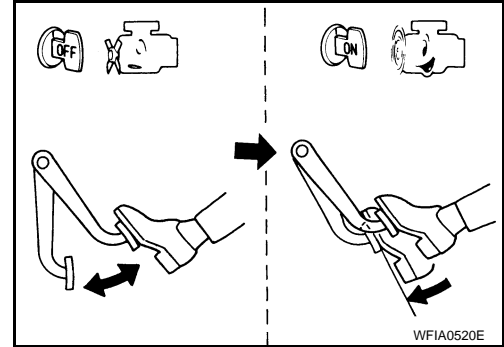

AIRTIGHT CHECK

- Run engine at idle for approximately 1 minute, and stop it after applying vacuum to booster. Depress brake pedal normally to change the vacuum to the atmospheric pressure. Make sure that distance between brake pedal and floor panel gradually increases.
- Depress the brake pedal while engine is running, then stop engine with brake pedal depressed. The pedal stroke should not change after holding pedal down for 30 seconds.

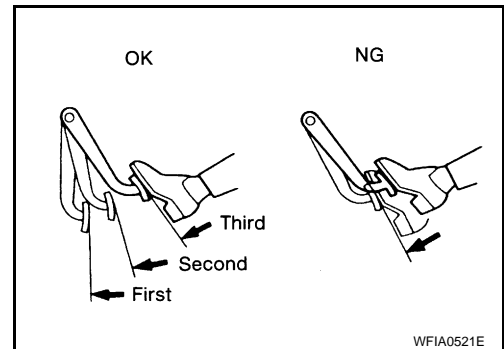

Removal and Installation

INFOID:000000001851314

COMPONENTS

BRAKE BOOSTER

< SERVICE INFORMATION >

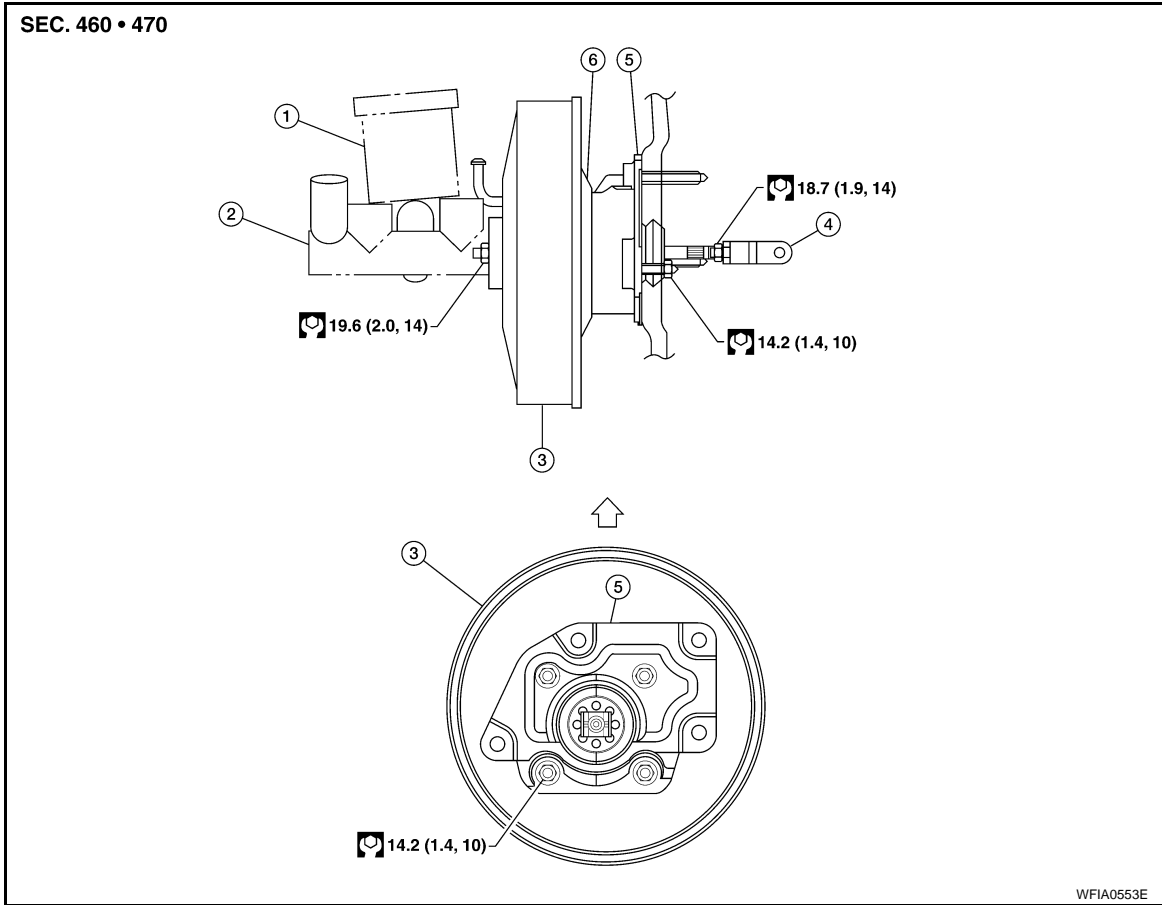

- | | | |
|-------------------|--------------------|------------------|
| 1. Reservoir tank | 2. Master cylinder | 3. Brake booster |
| 4. Clevis | 5. Spacer | 6. Gasket |
- ⇐: Up

REMOVAL

CAUTION:

- Be careful not to splash brake fluid on painted areas such as body. If brake fluid is splashed on painted surfaces of body, wipe them with cloth immediately and then wash it away with water.
- Be careful not to deform or bend brake tubes while removing and installing brake booster.
- Replace clevis pin if it is damaged.
- Be careful not to damage brake booster stud bolt threads. If brake booster is tilted or inclined during installation, dash panel may damage the threads.

1. Remove vacuum hose from brake booster.
2. Remove master cylinder assembly. Refer to [BR-15. "Removal and Installation"](#).
3. Remove snap pin and clevis pin on the clevis of the brake booster, and remove input rod from brake pedal.
4. Remove brake pedal nuts on pedal bracket.
5. Remove between spacer and dash panel nut from dash panel.
6. Remove brake booster and spacer from vehicle.
7. Remove spacer from brake booster.

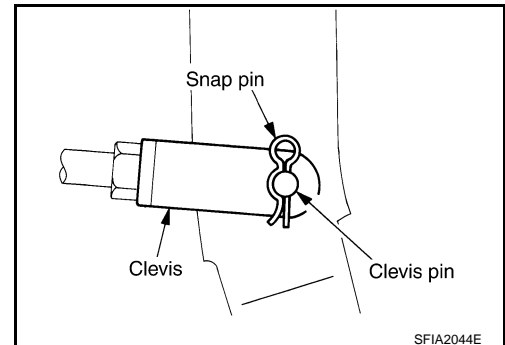

INSTALLATION

BRAKE BOOSTER

< SERVICE INFORMATION >

1. Loosen lock nut to adjust input rod length so that the length B satisfies the specified value.

Length "B" : 163.2 - 164.2 mm (6.43 - 6.46 in)

2. Install spacer to brake booster and tighten spacer nut (brake booster side) to the specified torque.
3. After adjusting length "B", temporarily tighten lock nut to install brake booster assembly to dash panel. At this time, make sure to install a gasket between brake booster and vehicle.

CAUTION:

Be sure to install the gasket between brake booster and vehicle.

4. Connect brake pedal to clevis of input rod with the clevis pin and snap pin.
5. Install brake pedal bracket nuts and tighten them to the specified torque.
6. Adjust the height and play of brake pedal. Refer to [BR-5, "Inspection and Adjustment"](#).
7. Tighten lock nut of input rod to the specified torque. Refer to [BR-6, "Removal and Installation"](#).
8. Install vacuum hose into brake booster. Refer to [BR-20, "Removal and Installation"](#).
9. Bleed air from brake system. Refer to [BR-8, "Bleeding Brake System"](#).

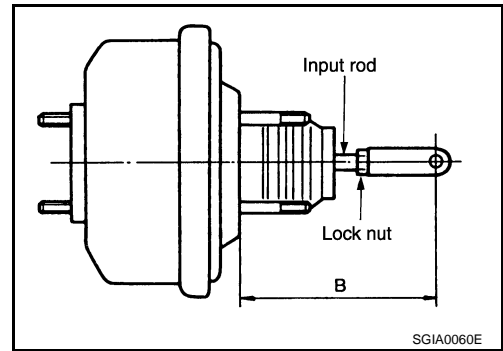

A
B
C
D
E
BR
G
H
I
J
K
L
M
N
O
P

VACUUM LINES

< SERVICE INFORMATION >

VACUUM LINES

Component

INFOID:000000001851315

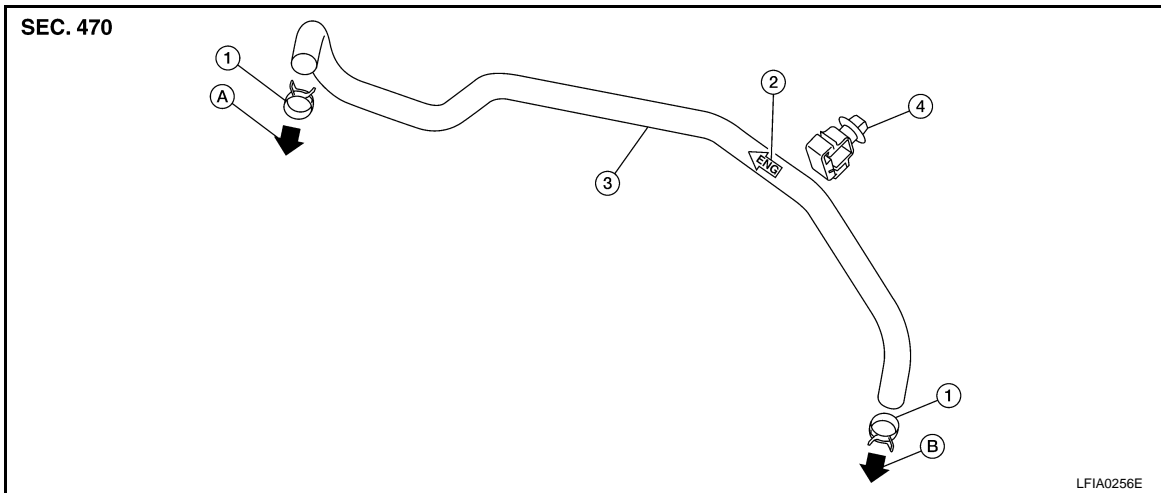

- | | | |
|----------|---|---------------------|
| 1. Clamp | 2. Engine side indicator stamp (built-in check valve) | 3. Vacuum hose |
| 4. Clip | A. To intake manifold | B. To brake booster |

Removal and Installation

INFOID:000000001851316

CAUTION:

- Because vacuum hose contains a check valve, it must be installed in the correct orientation. Refer to the stamp or label to confirm correct installation. Brake booster will not operate normally if hose is installed in the wrong direction.
- Insert vacuum hose at least 24 mm (0.94 in).
- Never use lubricating oil during assembly.

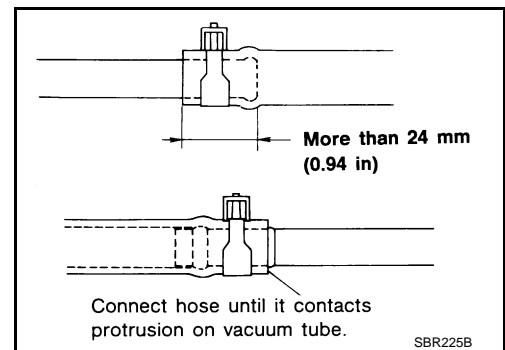

Inspection

INFOID:000000001851317

VISUAL INSPECTION

Check for improper assembly, damage and aging.

CHECK VALVE INSPECTION

Airtightness Inspection

VACUUM LINES

< SERVICE INFORMATION >

Use a handy vacuum pump to check.

When connected to booster side (1):

Vacuum decrease should be within 1.3 kPa (10 mmHg, 0.39 inHg) for 15 seconds under a vacuum of -66.7 kPa (-500 mmHg, -19.69 inHg)

When connected to engine side (2):

No vacuum will be applied

Replace vacuum hose with the check valve as a set if damage or deformation is present at the vacuum hose.

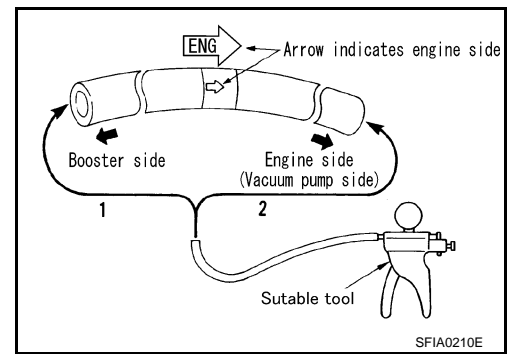

A
B
C
D
E
BR
G
H
I
J
K
L
M
N
O
P

FRONT DISC BRAKE

< SERVICE INFORMATION >

FRONT DISC BRAKE

On Board Inspection

INFOID:000000001851318

PAD WEAR INSPECTION

- Check pad thickness from check hole on cylinder body. Refer to [BR-39, "Front Disc Brake"](#).

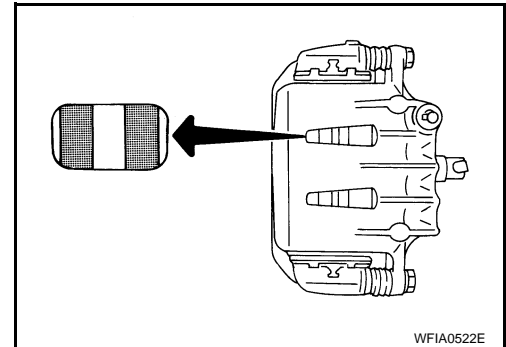

WFIA0522E

Component

INFOID:000000001851319

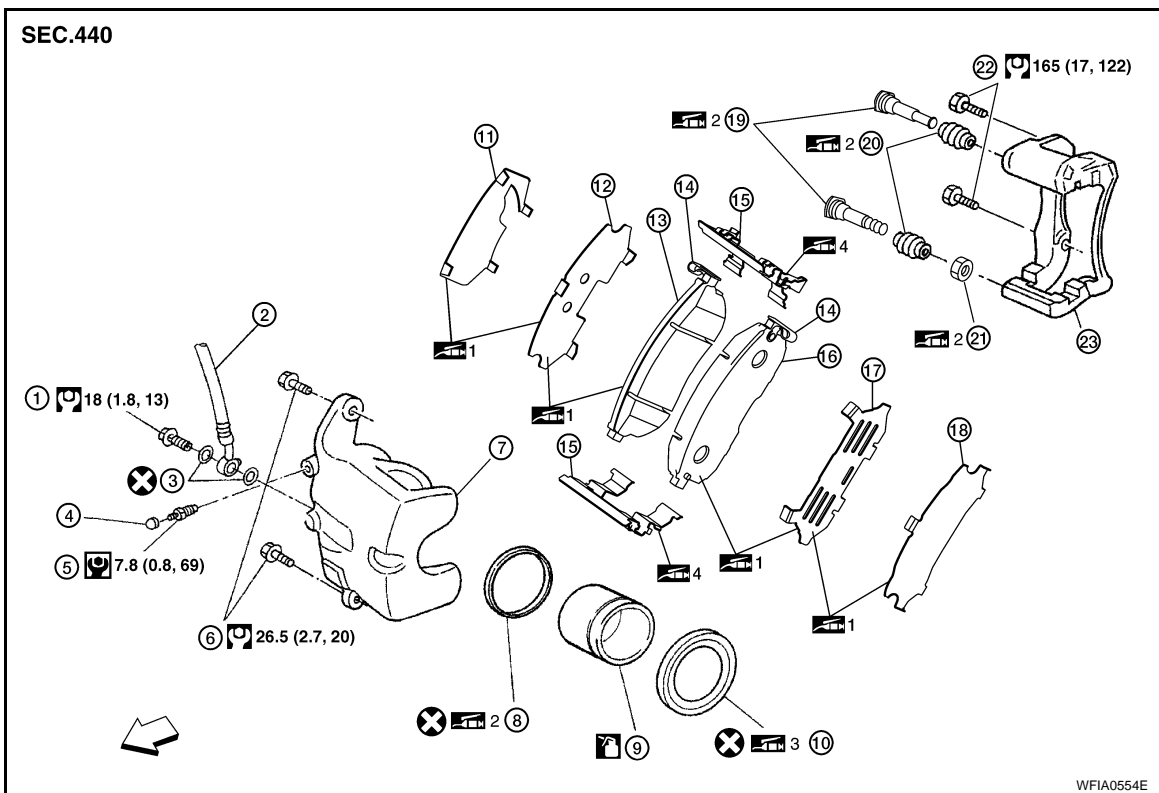

WFIA0554E

- | | | |
|-------------------------------------|----------------------|----------------------|
| 1. Union bolt | 2. Brake hose | 3. Copper washer |
| 4. Cap | 5. Bleed valve | 6. Sliding pin bolt |
| 7. Cylinder body | 8. Piston seal | 9. Piston |
| 10. Piston boot | 11. Inner shim cover | 12. Inner shim |
| 13. Inner pad | 14. Pad wear sensor | 15. Pad retainer |
| 16. Outer pad | 17. Outer shim | 18. Outer shim cover |
| 19. Sliding pin | 20. Sliding pin boot | 21. Bushing |
| 22. Torque member mounting bolt | 23. Torque member | ← : Front |
| : Brake fluid | 1: M-77 grease | 2: Rubber grease |
| 3: Polyglycol ether based lubricant | 4: M-7439 grease | |

CAUTION:

FRONT DISC BRAKE

< SERVICE INFORMATION >

- Clean dust on caliper and brake pad with a vacuum dust collector. Do not blow with compressed air.
- While removing brake pad or cylinder body, do not depress brake pedal because piston will pop out.
- It is not necessary to remove torque member mounting bolts and brake hose except for disassembly or replacement of caliper assembly. In this case, hang cylinder body with a wire so that brake hose is not under tension.
- Do not damage piston boot.
- If any shim is subject to serious corrosion, replace it with a new one.
- Keep rotor free from brake fluid.
- When replacing brake pad, replace shim with a new one.

Removal and Installation of Brake Pad

INFOID:000000001851320

REMOVAL

1. Remove tires from vehicle.
2. Remove sliding pin bolt (lower side).
3. Hang cylinder body with a wire, and remove pads, shims and pad retainers from torque member.

CAUTION:

When removing pad retainer from torque member, lift pad retainer in the direction shown by arrow, so as not to deform it.

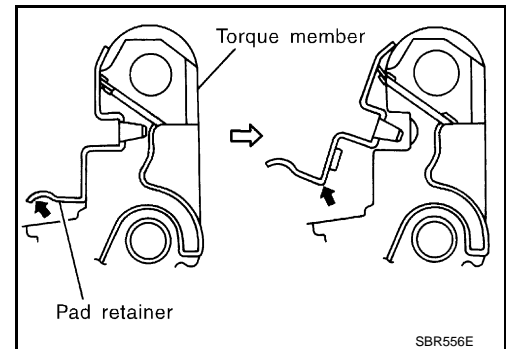

INSTALLATION

1. Apply Molykote M-77 grease or equivalent to the shims. Install shims to pads.

CAUTION:

Securely install shims according to mounting direction of pads.

2. Apply Molykote M-7439 grease or equivalent to pad contact surface on pad retainers. Install pad retainers and pads to the torque member.

CAUTION:

When installing pad retainer, attach it firmly so that it is not lifted up from torque member, as shown.

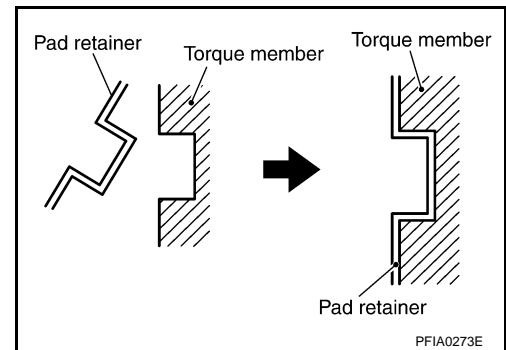

3. Install cylinder body to torque member.

NOTE:

Press to piston into cylinder body using a suitable tool.

CAUTION:

Check the brake fluid level in the reservoir tank for fluid level because brake fluid returns to master cylinder reservoir tank when pressing piston in.

4. Install lower sliding pin bolt (lower side), and tighten it to the specified torque. Refer to [BR-22, "Component"](#).
5. Check brake for drag.
6. Install tires to the vehicle.

FRONT DISC BRAKE

< SERVICE INFORMATION >

Removal and Installation of Brake Caliper Assembly

INFOID:000000001851321

REMOVAL

1. Remove tires from vehicle.
2. Secure disc rotor using wheel nuts.
CAUTION:
Put matching marks on wheel hub assembly and disc rotor, if it is necessary to remove disc rotor.
3. Drain brake fluid. Refer to [BR-8, "Drain and Refill"](#).
4. Remove union bolt, and then remove brake hose from caliper assembly.
5. Remove torque member bolts from torque member, and remove caliper assembly from vehicle.

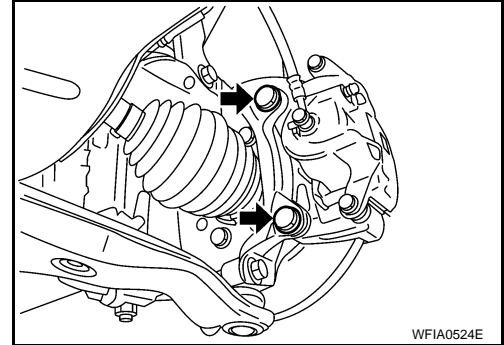

INSTALLATION

1. Install caliper assembly to vehicle, and tighten mounting bolts to the specified torque. Refer to [BR-22, "Component"](#).
CAUTION:
Before installing torque member to vehicle, wipe oil and grease on mounting surface of steering knuckle and torque member.
2. Install brake hose to caliper assembly. Refer to [BR-10](#).
3. Refill with new brake fluid and bleed air. Refer to [BR-8, "Bleeding Brake System"](#).
4. Check front disc brake for drag.
5. Install tires to the vehicle.

Disassembly and Assembly of Brake Caliper Assembly

INFOID:000000001851322

NOTE:

Do not remove torque member, brake pads, shims and pad retainers, when disassembling or assembling cylinder body.

DISASSEMBLY

1. Remove caliper assembly from vehicle. Refer to [BR-24, "Removal and Installation of Brake Caliper Assembly"](#).
2. Remove sliding pin bolts from cylinder body, and remove pads, shims and pad retainers from torque member, if necessary.
CAUTION:
When removing pad retainer from torque member, lift the pad retainer in the direction shown by arrow, so as not to deform it.

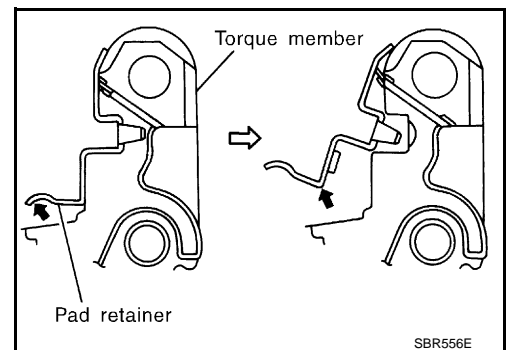

FRONT DISC BRAKE

< SERVICE INFORMATION >

3. Remove sliding pins and sliding pin boots from torque member.
4. Place a wooden block as shown, and blow air from union bolt hole to remove piston and piston boot.

CAUTION:

Do not get fingers caught in the piston.

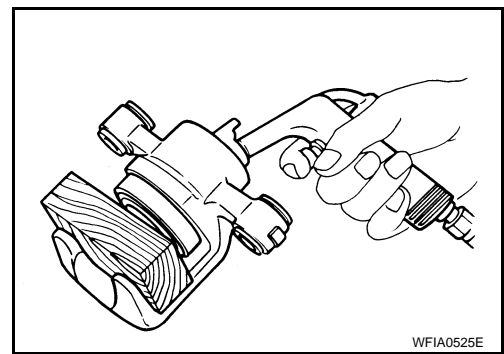

5. Remove piston seal using a suitable tool.

CAUTION:

Be careful not to damage the inner wall of cylinder.

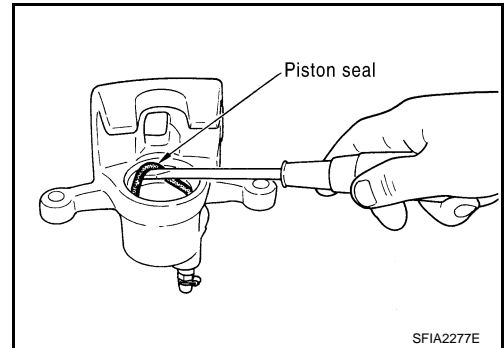

INSPECTION AFTER DISASSEMBLY

Cylinder Body

Check the inner wall of cylinder for corrosion, wear, and damage. Replace cylinder body as necessary.

CAUTION:

Clean cylinder body using new brake fluid. Never use mineral oils such as gasoline or kerosene.

Torque Member

Check for wear, cracks, and damage. Replace torque member as necessary..

Piston

Check piston surface for corrosion, wear, and damage. Replace piston as necessary.

CAUTION:

The piston sliding surface is plated. Do not polish with sandpaper.

Sliding Pin, Sliding Pin Bolt, and Sliding Pin Boot

Check sliding pins, sliding pin bolts and sliding pin boots for wear, damage, and cracks. Replace applicable part as necessary.

ASSEMBLY

CAUTION:

When assembling, use only specified rubber lubricant.

1. Apply polyglycol ether based lubricant to new piston seal and install them to cylinder body.

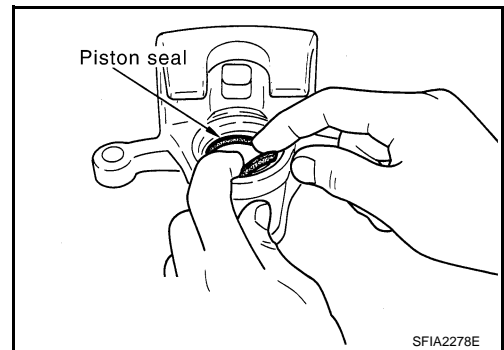

A
B
C
D
E
BR
G
H
I
J
K
L
M
N
O
P

FRONT DISC BRAKE

< SERVICE INFORMATION >

2. Apply rubber grease to piston boot and apply brake fluid to piston. Cover the piston end with piston boot, and install cylinder-side lip on piston boot properly into groove on cylinder body.

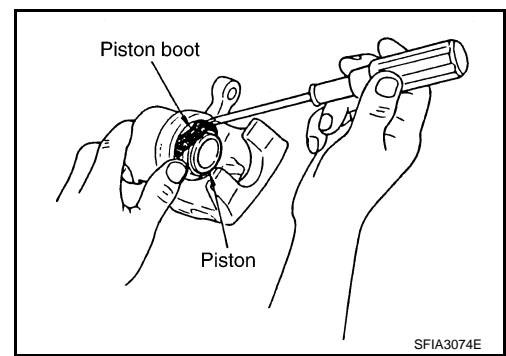

3. Press piston into cylinder body by hand to assemble piston-side lip on piston boot properly into a groove on piston.

CAUTION:

Press piston evenly and change pressing point to prevent inner wall of cylinder from being rubbed.

4. Install sliding pins and sliding pin boots to the torque member.

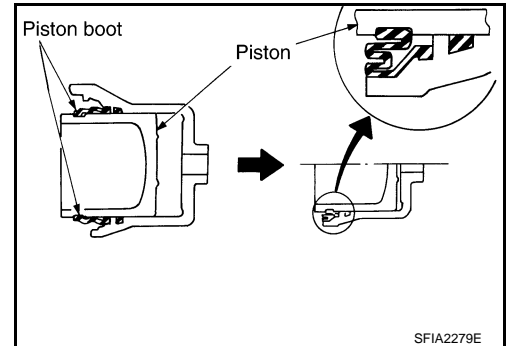

5. If pads, shims and pad retainers were removed, install them to torque member. Refer to [BR-24. "Removal and Installation of Brake Caliper Assembly"](#).
6. Install cylinder body to torque member.
7. Install sliding pin bolts.
8. Install caliper assembly to vehicle. Refer to [BR-24. "Removal and Installation of Brake Caliper Assembly"](#).
9. Tighten sliding pin bolts to specified torque. Refer to [BR-22. "Component"](#).

DISC ROTOR INSPECTION

Visual Inspection

Check surfaces of disc rotor for uneven wear, cracks, and serious damage. Replace applicable part as necessary.

Runout Inspection

1. Secure disc rotor to wheels hub 2 or more positions, using wheel nuts.
2. Using a dial indicator, check runout.

CAUTION:

Make sure that wheel bearing axial end play is within the specifications before measuring runout. Refer to [FAX-5, "On-Vehicle Inspection and Service"](#).

Runout limit : Refer to [BR-39, "Front Disc Brake"](#).

3. If runout is outside the limit, find the minimum runout point by shifting the mounting positions of disc rotor and wheel hub by one hole.

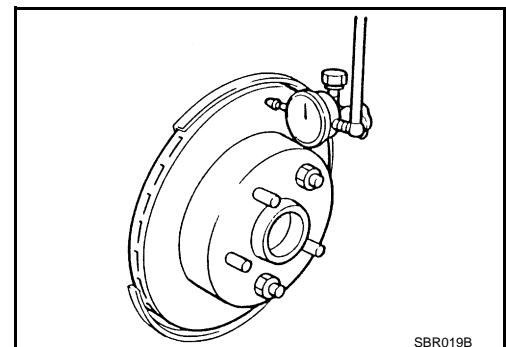

Thickness Inspection

FRONT DISC BRAKE

< SERVICE INFORMATION >

1. Using a micrometer, check thickness of disc rotor. If thickness is outside the standard, replace disc rotor. Refer to [BR-39, "Front Disc Brake"](#).
2. If runout is still out of the specification, grind rotor with on-car brake lathe ("MAD, DL-8700", "AMMCO 700 and 705" or equivalent) until runout becomes within the specified limit.

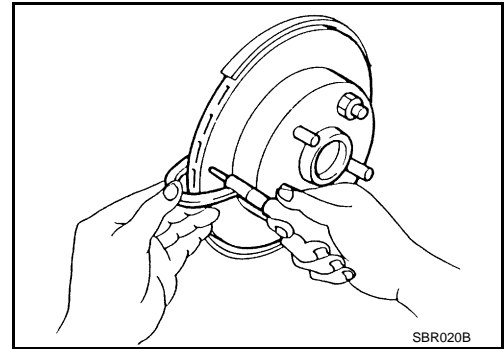

INFOID:000000001851323

Brake Burnishing

Burnish the new braking surfaces according to following procedure after refinishing or replacing disc rotors, pads, or if a soft pedal occurs at very low mileage.

CAUTION:

- **Be careful of vehicle speed because brake does not operate easily until pad and disc rotor are securely fitted.**

- **Only perform this procedure under safe road and traffic conditions. Use extreme caution.**

1. Drive vehicle on straight, flat road.
2. Depress brake pedal with the power to stop vehicle within 3 to 5 seconds until the vehicle stops.
3. Drive without depressing brake pedal for a few minutes to cool brake.
4. Repeat steps 1 to 3 until pad and disc rotor are securely fitted.

REAR DISC BRAKE

< SERVICE INFORMATION >

REAR DISC BRAKE

On Board Inspection

INFOID:000000001851324

PAD WEAR INSPECTION

- Inspect the thickness of the pad through the caliper inspection hole. Use a ruler or caliper for inspection if necessary. Refer to [BR-40](#), "Rear Disc Brake".

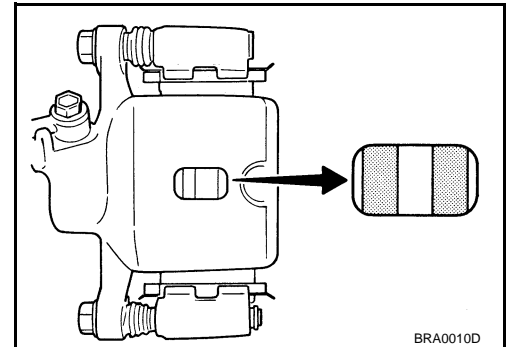

Component

INFOID:000000001851325

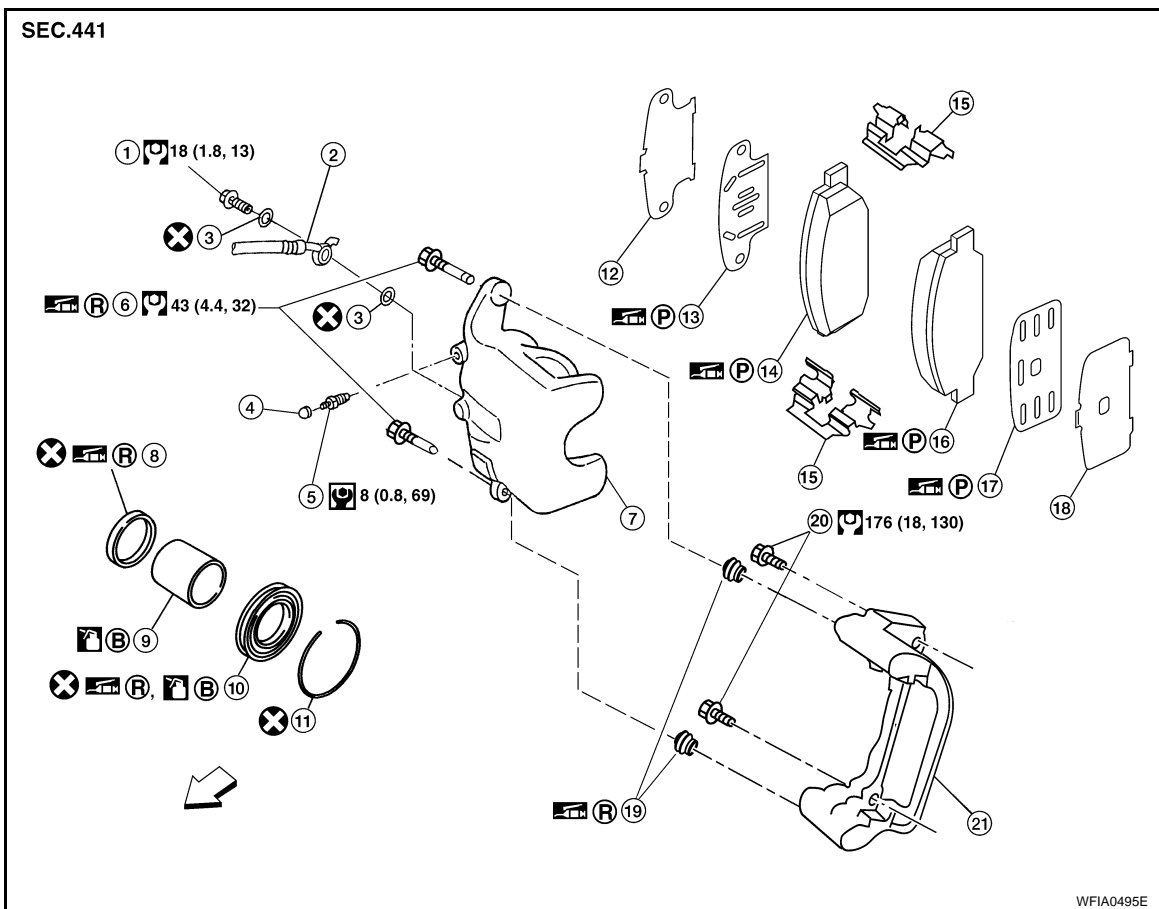

- | | | |
|----------------------|-------------------------|----------------------|
| 1. Union bolt | 2. Brake hose | 3. Copper washer |
| 4. Cap | 5. Air bleeder | 6. Sliding pin |
| 7. Cylinder body | 8. Piston seal | 9. Piston |
| 10. Piston boot | 11. Retaining ring | 12. Inner shim cover |
| 13. Inner shim | 14. Inner pad | 15. Pad retainer |
| 16. Outer pad | 17. Outer shim | 18. Outer shim cover |
| 19. Sliding pin boot | 20. Torque member bolts | 21. Torque member |
- ← Front

REAR DISC BRAKE

< SERVICE INFORMATION >

Removal and Installation of Brake Pad

INFOID:000000001851326

REMOVAL

1. Remove master cylinder reservoir cap.
2. Remove tires from vehicle with power tool.
3. Remove bottom sliding pin bolt.
4. Hang cylinder body with a wire, and remove pads, pad retainers, shims from torque member.

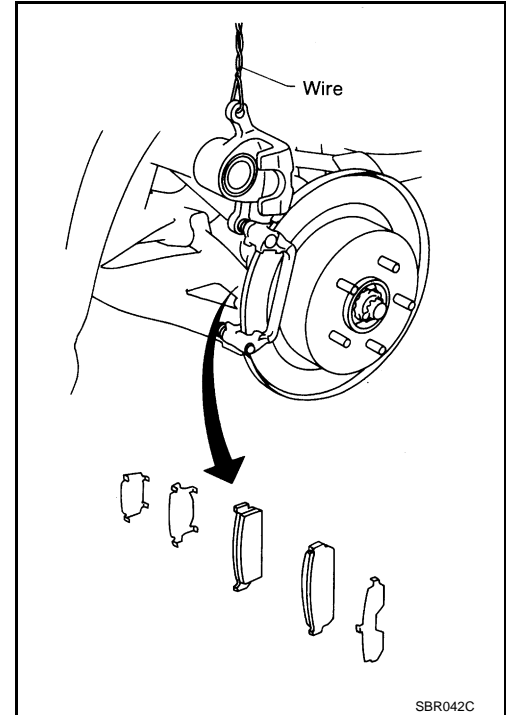

INSTALLATION

1. Apply PBC (Poly Butyl Cuprysil) grease or silicone-based grease between pad plate and shim, shim and shim cover, and shim cover and piston. Refer to [MA-13](#).
2. Attach the inner shim and shim cover to the inner pad, and the outer shim and outer shim cover to the outer pad.
3. Attach the pad retainer and pad to the torque member.
4. Push the piston in so that the pad is firmly attached and attach the cylinder body to the torque member.

NOTE:

Press the piston into the cylinder body using a suitable tool.

CAUTION:

By pushing in the piston, the brake fluid returns to the master cylinder reservoir tank. Watch the level of the surface of the reservoir tank.

5. Install the sliding pin bolt and tighten to the specified torque. Refer to [BR-28. "Component"](#).
6. Inspect brake fluid level, then install master cylinder reservoir cap.
7. Check brake for drag.
8. Attach the tires to the vehicle. Refer to [WT-8. "Rotation"](#).

CAUTION:

Burnish the brake contact surfaces when refinishing or replacing brake rotors, after replacing pads or linings, or if a soft pedal occurs at very low mileage. Refer to [BR-33. "Brake Burnishing"](#).

Removal and Installation of Caliper Assembly

INFOID:000000001851327

REMOVAL

1. Remove master cylinder reservoir cap.
2. Remove tires from vehicle using power tool.
3. Drain brake fluid. Refer to [BR-8. "Bleeding Brake System"](#).

REAR DISC BRAKE

< SERVICE INFORMATION >

4. Remove union bolt and torque member bolts using power tool, and remove cylinder body.

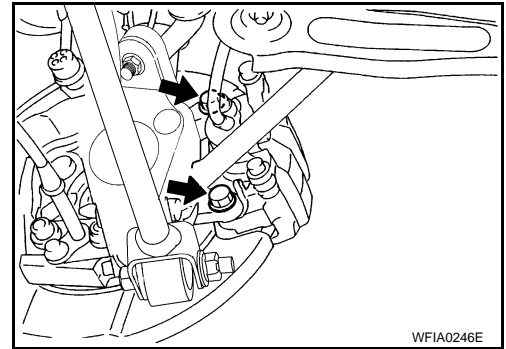

5. Remove caliper and disc rotor. If the disc rotor cannot be removed, remove as follows:

- Make sure parking brake lever is completely disengaged.
- Hold down the disc rotor with the wheel nut and remove the adjuster hole plug.
- Insert a flat-bladed screwdriver through the plug opening and rotate the star wheel on the adjuster assembly in the direction shown to loosen and retract the brake shoes.
- Prior to removing disc rotor, make alignment mark using a marker between the hub and disc rotor.
- Remove wheel nut and rotor.

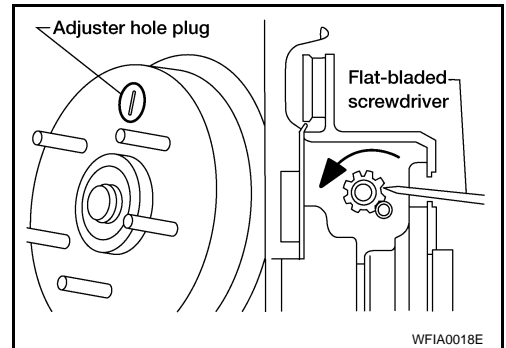

INSTALLATION

CAUTION:

- Refill with new brake fluid. Refer to [MA-13](#).
- Never reuse drained brake fluid.

1. Install disc rotor.
 - Align marks made during removal on the hub and disc rotor.
2. Install cylinder body to the vehicle, and tighten torque member bolts to the specified torque. Refer to [BR-28, "Component"](#).

CAUTION:

Before installing cylinder body to the vehicle, wipe off oil and grease on washer seats on axle assembly and mounting surface of cylinder body.

3. Install brake hose to cylinder body and tighten union bolt to the specified torque. Refer to [BR-28, "Component"](#).

CAUTION:

- Do not reuse the copper washer for connecting bolts.
- Securely attach brake hose to protrusion on cylinder body.

4. Add new brake fluid and bleed air. Refer to [BR-8, "Bleeding Brake System"](#).
5. Install master cylinder reservoir cap.
6. Adjust the parking brake. Refer to [PB-4, "On-Vehicle Service"](#).
7. Attach the tires to the vehicle. Refer to [WT-8, "Rotation"](#).

CAUTION:

Burnish the brake contact surfaces when refinishing or replacing brake rotors, after replacing pads, or if a soft pedal occurs at very low mileage. Refer to [BR-33, "Brake Burnishing"](#).

Disassembly and Assembly of Caliper Assembly

INFOID:000000001851328

DISASSEMBLY

1. Remove the sliding pin bolt, and then remove the pad, shim, shim cover, and pad retainer from the torque member and cylinder.
2. Remove sliding pin boot from torque member.

REAR DISC BRAKE

< SERVICE INFORMATION >

3. Remove the retaining ring from the cylinder body using a suitable tool, as shown.

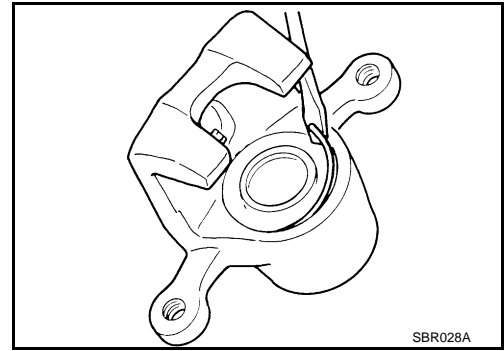

4. Place a wooden block as shown, and blow air from connecting bolt hole to remove pistons and piston boots.

WARNING:

Do not place your finger in front of piston.

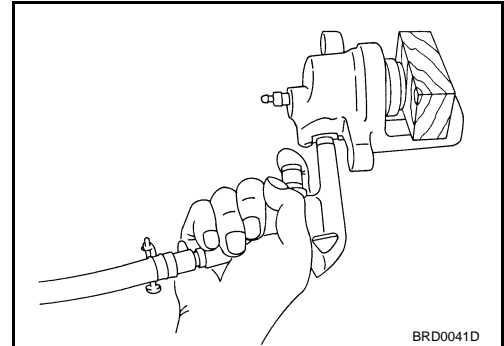

5. Remove piston seals from cylinder body using a suitable tool, as shown.

CAUTION:

Be careful not to damage cylinder inner wall.

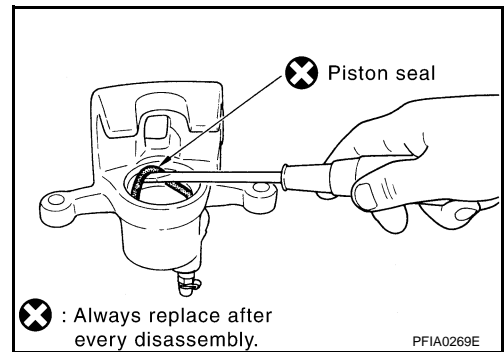

CALIPER INSPECTION

Cylinder Body

CAUTION:

- Use new brake fluid to clean. Never use mineral oils such as gasoline or kerosene.
- Check inner wall of cylinder for corrosion, wear, and damage. If any non-standard condition is detected, replace cylinder body.
- Minor flaws caused by corrosion or a foreign material can be removed by polishing the surface with a fine sandpaper. Replace the cylinder body, if necessary.

Torque Member

Check for wear, cracks, and damage. If damage or deformation is present, replace the affected part.

Piston

CAUTION:

Since the piston surface is plated, do not repair using sandpaper.

Check piston surface for corrosion, wear, and damage. If any non-standard condition is detected, replace applicable part.

Sliding Pin Bolts and Sliding Pin Boots

Check that there is no wear, damage, or cracks in the sliding pin bolts and sliding pin boots, and if there are, replace them.

ASSEMBLY

CAUTION:

Do not use Nissan Rubber Grease (KRE00 00010 or KRE00 00010 01) when assembling.

A
B
C
D
E
BR
G
H
I
J
K
L
M
N
O
P

REAR DISC BRAKE

< SERVICE INFORMATION >

1. Apply a rubber grease to the piston seal and attach to cylinder body.

CAUTION:

Do not reuse the piston seals.

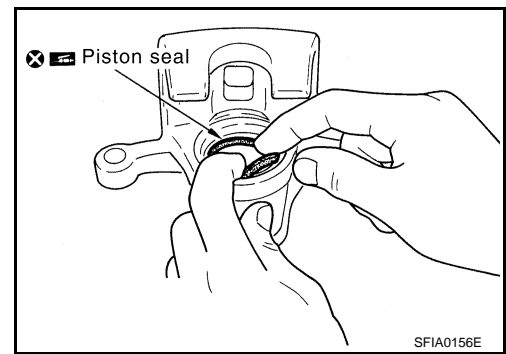

2. Apply brake fluid or rubber grease to the piston boot, place it on the piston, and firmly insert the piston boot cylinder-side lip into the cylinder body groove.

CAUTION:

Do not reuse the piston boot.

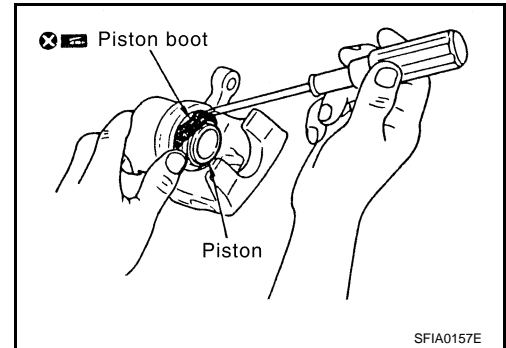

3. Apply a brake fluid to the piston, insert into the cylinder body by hand and firmly attach the piston boot piston-side lip into the piston boot.

CAUTION:

Press the piston evenly and vary the pressing point to prevent cylinder inner wall from being rubbed.

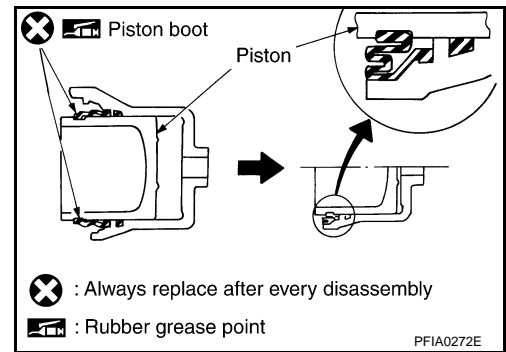

4. Fix piston boot with retaining ring.

CAUTION:

- Make sure the boot is firmly in the cylinder body groove.
- Do not reuse the retaining ring.

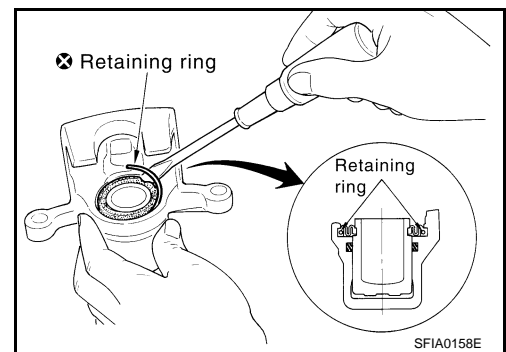

5. Attach the sliding pin bolt and sliding pin boot to the torque member.
6. Apply PBC (Poly Butyl Cuprysil) grease or silicone-based grease to the rear of the pad and to both sides of the shim, and attach the inner shim and shim cover to the inner pad, and the outer shim and outer shim cover to the outer pad.

REAR DISC BRAKE

< SERVICE INFORMATION >

7. Attach the pad retainer and pad to the torque member.

CAUTION:

When attaching the pad retainer, attach it firmly so that it does not float up higher than the torque member, as shown in the figure.

8. After assembling shims and shim covers to pad, install it to the torque member.
9. Install cylinder body. Tighten sliding pin bolts to the specified torque.

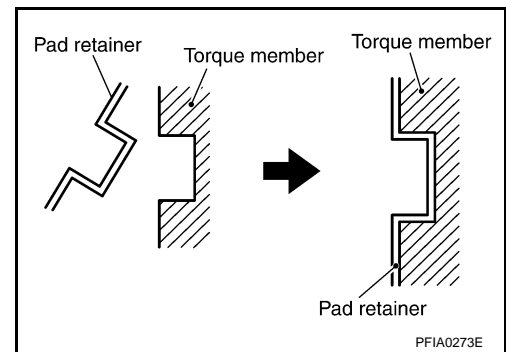

DISC ROTOR INSPECTION

Visual Inspection

Check surface of the disc rotor for uneven wear, cracks, and serious damage. If any non-standard condition is detected, replace applicable part.

Runout Inspection

1. Secure disc rotor to the wheel hub in two or more positions, using wheel nuts.
2. Inspect runout using a dial gauge [At a point 10 mm (0.39 in)]. Refer to [BR-40, "Rear Disc Brake"](#).
CAUTION:
Before measuring, make sure the axle endplay is 0 mm (0 in).
3. If runout is outside the limit, find the minimum runout point by shifting mounting positions of the disc rotor and wheel hub by one hole.

Thickness Inspection

Using a micrometer, check thickness of the disc rotor. If thickness is not within specification, replace disc rotor. Refer to [BR-40, "Rear Disc Brake"](#).

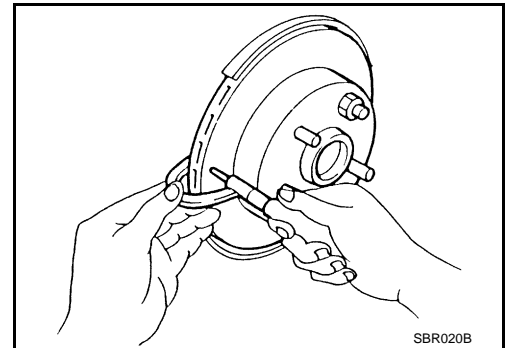

Brake Burnishing

INFOID:000000001851329

Burnish the brake contact surface according to the following procedure after refinishing or replacing rotors, after replacing pads, or if a soft pedal occurs at very low mileage.

CAUTION:

Only perform this procedure under safe road and traffic conditions. Use extreme caution.

1. Drive the vehicle on a straight smooth road at 50 km/h (31 MPH).
2. Use medium brake pedal /foot effort to bring the vehicle to a complete stop from 50 km/h (31 MPH). Adjust brake pedal /foot pressure such that vehicle stopping time equals 3 to 5 seconds.
3. To cool the brake system, drive the vehicle at 50 km/h (31 MPH) for 1 minute without stopping.
4. Repeat steps 1 to 3, 10 times or more to complete the burnishing procedure.

REAR DRUM BRAKE

< SERVICE INFORMATION >

REAR DRUM BRAKE

Component

INFOID:000000001851330

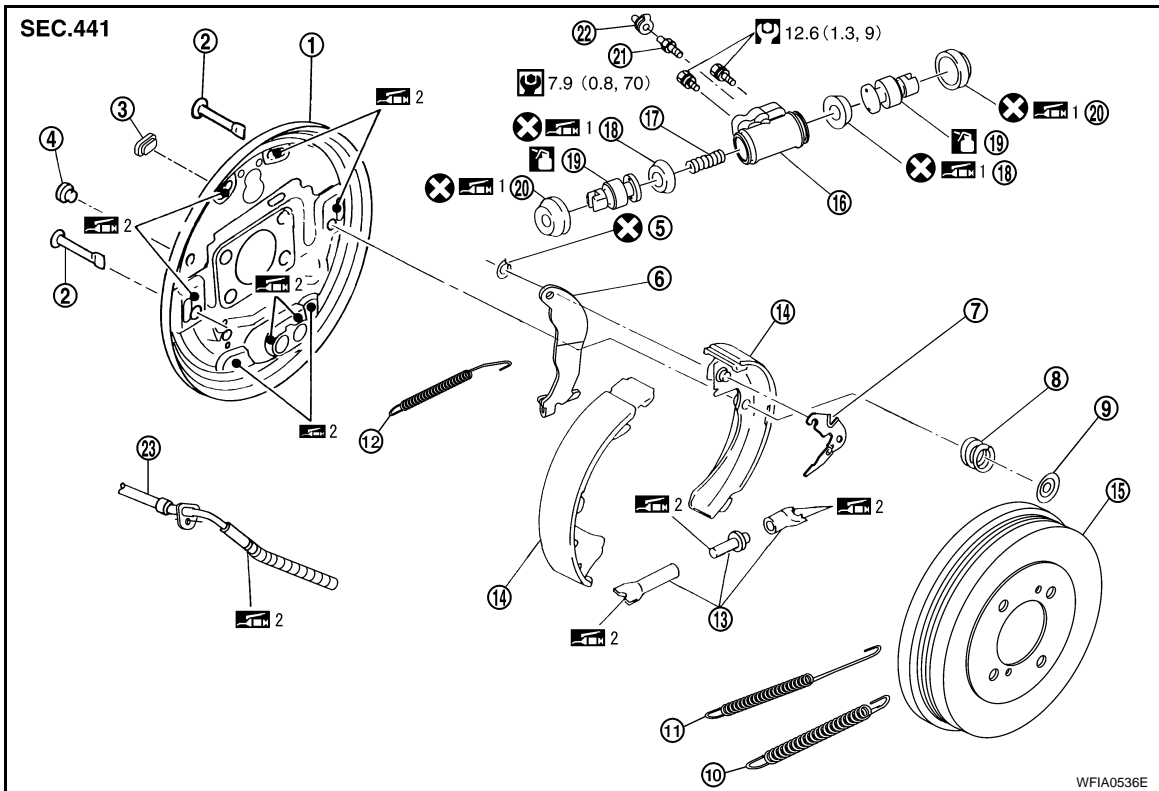

WFIA0536E

- | | | |
|--------------------------------|--------------------------------|---------------------|
| 1. Back plate | 2. Shoe hold pin | 3. Plug |
| 4. Plug | 5. Retainer ring | 6. Operating lever |
| 7. Adjuster lever | 8. Spring | 9. Retainer |
| 10. Return spring (lower side) | 11. Return spring (upper side) | 12. Adjuster spring |
| 13. Adjuster | 14. Brake shoe | 15. Brake drum |
| 16. Wheel cylinder | 17. Spring | 18. Piston seal |
| 19. Piston | 20. Boot | 21. Bleed valve |
| 22. Cap | 23. Parking brake rear cable | |

1: PBC (Poly Butyl Cuprysil) grease or silicone-based grease

2: Rubber grease

: Brake fluid

CAUTION:

- Clean dust on drum and back plate with a vacuum dust collector. Do not blow with compressed air.
- Make sure parking brake lever is released completely.

Removal and Installation of Drum Brake Assembly

INFOID:000000001851331

REMOVAL

1. Remove tire from the vehicle.
2. With the parking brake lever released, remove the brake drum. If it is difficult to remove brake drum, remove as follows:

REAR DRUM BRAKE

< SERVICE INFORMATION >

- a. Press up adjuster lever with a wire or equivalent from plug hole (plug hole at the side of wheel cylinder) on the back plate as shown. Turn frame of adjuster assembly using a suitable tool in the direction that narrows frame to narrow enlarged brake shoe.

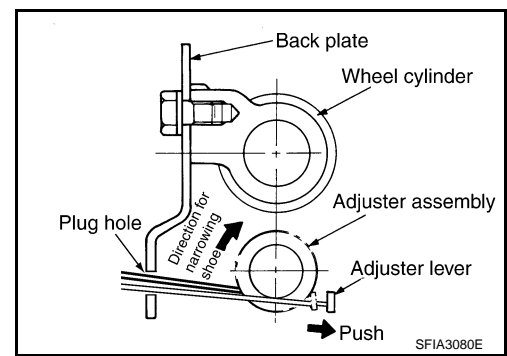

3. While pushing and rotating the retainer, pull out shoe hold pin, and remove shoe assembly.

CAUTION:

Do not damage the wheel cylinder boot.

4. Remove the parking brake rear cable from the operating lever.

CAUTION:

Do not bend the parking brake cable.

5. Disassemble the shoe assembly (shoe, springs, adjuster, adjuster lever).

6. Remove retainer ring (A) with a tool to separate operating lever (C) from brake shoe.

- Retainer ring (A)
- Contact point (B)
- Operating lever (C)
- Pin (D)

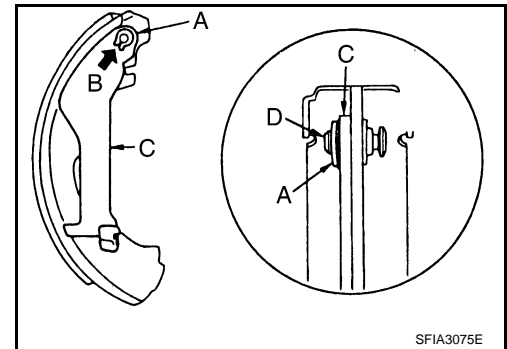

INSPECTION AFTER REMOVAL

Lining Thickness Inspection

Check lining thickness.

Standard thickness (A) : 4.0 mm (0.157 in)

Repair limit thickness (A) : 1.5 mm (0.059 in)

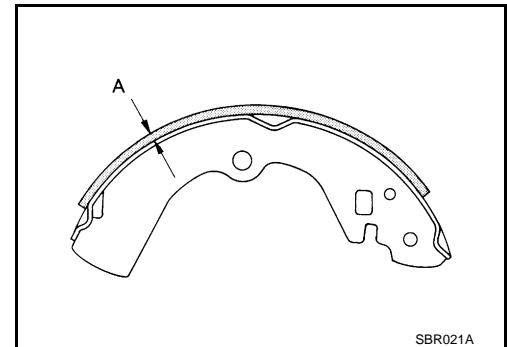

Drum Inner Diameter Inspection

Check inner diameter of brake drum.

Measurement area: lining contact surface (center)

Standard inner diameter : 228.6 mm (9.000 in) dia.

Repair limit inner diameter : 230.0 mm (9.055 in) dia.

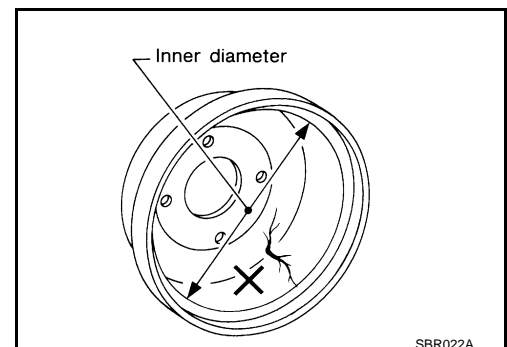

Wheel Cylinder Leakage Inspection

A
B
C
D
E
BR
G
H
I
J
K
L
M
N
O
P

REAR DRUM BRAKE

< SERVICE INFORMATION >

- Check wheel cylinder for brake fluid leakage.
- Check for wear, damage, and looseness. If any non-standard condition is found, replace it.

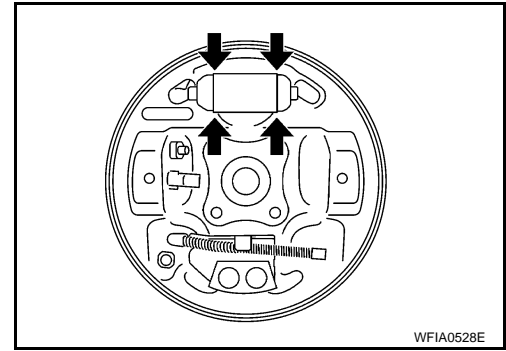

Other Inspections

Check the following:

- Inside of the drum for excessive wear, damage, and cracks.
 - Lining for excessive wear, damage, and peeling.
 - Shoe sliding surface for excessive wear and damage.
 - Return spring for sagging.
 - Check back plate for damage, cracks, and deformation. Replace back plate as necessary.
- Replace applicable part as necessary.

INSTALLATION

1. If operating lever (C) if removed.
 - a. Install operating lever (C) to brake shoe.
 - b. Install retainer ring (A) to operating lever (C), and crimp them until their contact points (B) are met.
 - Retainer ring (A)
 - Contact point (B)
 - Operating lever (C)
 - Pin (D)

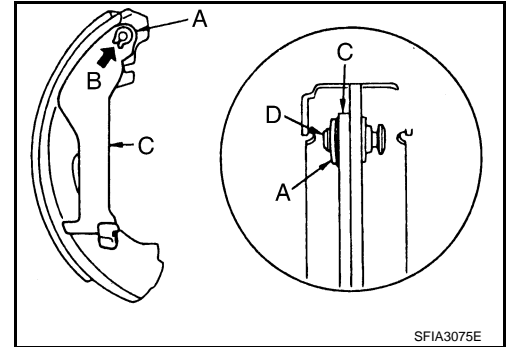

2. Apply NISSAN brake grease (KRF0000005) to brake shoes sliding surfaces (the shaded areas) and other parts on the back plate as indicated by arrows.

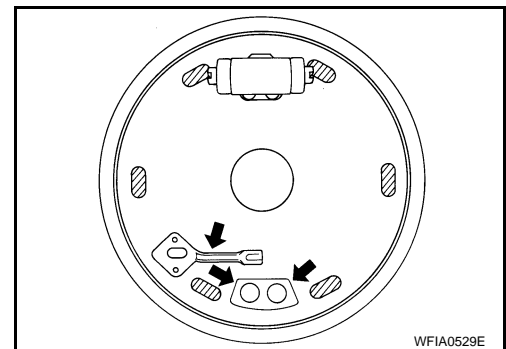

3. Apply NISSAN brake grease (KRF00 00005) to screw and confirm the difference between right and left wheel for assembling when disassembled.

Right rear wheel **Thread cutting direction** : **Right-hand screw**

Left rear wheel **Thread cutting direction** : **Left-hand screw**

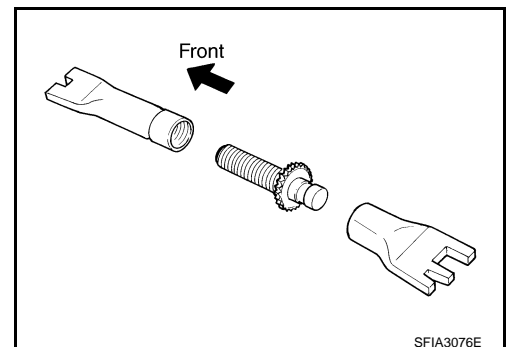

4. Assemble the shoe, adjuster, adjuster lever and springs to the shoe assembly.

REAR DRUM BRAKE

< SERVICE INFORMATION >

5. Connect the parking brake rear cable to the operating lever.
6. Install the shoe assembly. After assembly, be sure that each part is installed properly.
CAUTION:
Do not damage the wheel cylinder piston boot.
7. Install the brake drum.
8. Depress brake pedal for several times (approximately 2, 3 times).
9. Adjust clearance of brake shoe. Refer to [PB-4, "On-Vehicle Service"](#).
10. Install tires to the vehicle.

Removal and Installation of Wheel Cylinder

INFOID:000000001851332

REMOVAL

1. Drain brake fluid. Refer to [BR-8, "Drain and Refill"](#).
2. Remove the rear brake shoe assembly. Refer to [BR-34, "Removal and Installation of Drum Brake Assembly"](#).
3. Remove the brake tube from the wheel cylinder.
4. Remove bolts on the wheel cylinder, and then remove wheel cylinder from the back plate.

INSTALLATION

- Installation is the reverse order of removal. Tighten bolts to the specified torque. Refer to [BR-34, "Removal and Installation of Drum Brake Assembly"](#).
- Refill with new brake fluid and bleed air. Refer to [BR-8, "Bleeding Brake System"](#).

Disassembly and Assembly of Wheel Cylinder

INFOID:000000001851333

DISASSEMBLY

1. Remove boots at the right and left of the wheel cylinder, and pull out the pistons from cylinder.
2. Remove piston from piston cup.

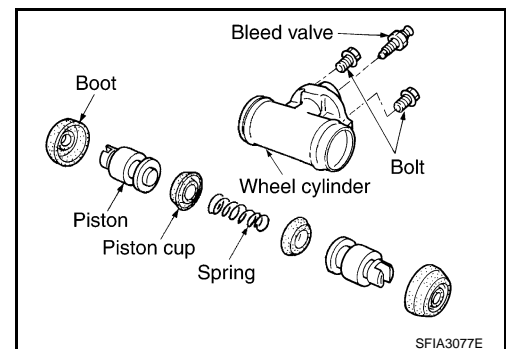

INSPECTION AFTER DISASSEMBLY

Check the pistons, piston cups, and inner wall of the cylinder for wear, corrosion, and damage. If malfunction is detected, replace it.

ASSEMBLY

CAUTION:

- Do not use Nissan rubber grease (KRE0000010, KRE000001001) during assembly.
- When inserting the piston, be careful not to scratch the cylinder.

1. Apply brake fluid to the piston sliding surface on the wheel cylinder.
2. Apply Nissan rubber lubricant (KRE1200030) to the piston cups and piston boots and assemble as shown.

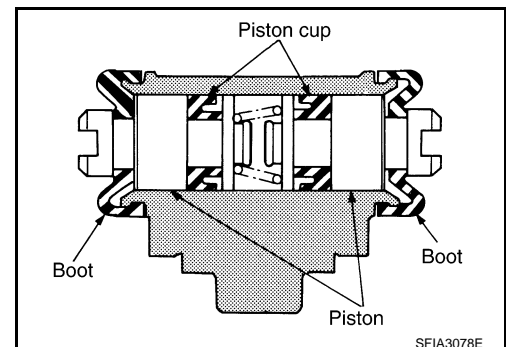

SERVICE DATA AND SPECIFICATIONS (SDS)

< SERVICE INFORMATION >

SERVICE DATA AND SPECIFICATIONS (SDS)

General Specification

INFOID:000000001851334

Applied model		MR20DE	QR25DE	
		Base	SE-R	SE-R Spec-V
Front disc brake	Brake model	CLZ25VF	CLZ25VJ	AD25V
	Cylinder bore diameter	57.2 mm (2.252 in)	57.2 mm (2.252 in)	57.15 mm (2.250 in)
	Pad thickness	11 mm (0.433 in)	11 mm (0.433 in)	11 mm (0.433 in)
	Rotor outer diameter × thickness	280 mm × 24.0 mm (11.02 in × 0.945 in)	296 mm × 26.0 mm (11.65 in × 1.024 in)	320 mm × 28.0 mm (12.60 in × 1.102 in)
Rear disc brake	Cylinder bore diameter	—	34.93 mm (1.375 in)	
	Pad thickness	—	8.5 mm (0.335 in)	
	Rotor outer diameter × thickness	—	292 mm × 9.0 mm (11.50 in × 0.354 in)	
Rear drum brake	Brake model	LT20D	—	—
	Cylinder bore diameter	15.87 mm (0.625 in)	—	—
	Lining Length × width × thickness	194.1 mm × 30.0 mm × 4.0 mm (7.642 in × 1.181 in × 0.157 in)	—	—
	Drum inner diameter	228.6 mm (9.000 in)	—	—
Master cylinder	Cylinder bore diameter	22.22 mm (0.875 in)		
Control valve	Valve model	Electric brake force distribution		
Brake booster	Booster model	C255		
	Diaphragm diameter	255 mm (10.04 in)		
Recommended brake fluid		Refer to MA-13 .		

SERVICE DATA AND SPECIFICATIONS (SDS)

< SERVICE INFORMATION >

Brake Pedal

INFOID:000000001851335

Unit: mm (in)

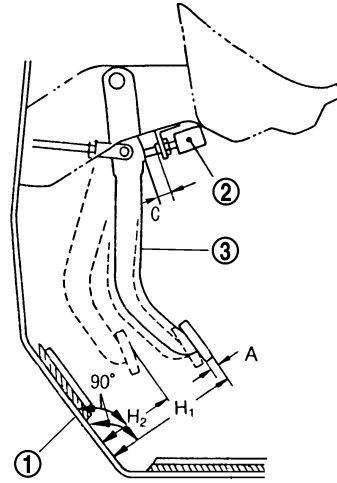

WFIA0511E

H1	Brake pedal initial height (from dash panel top surface)	164.0 - 174.0 mm (6.45 - 6.85 in)
H2	Brake pedal depressed height (under a force of 490 N (50 kg-f, 110 lb-f) with the engine running)	—
C	Clearance between the threaded end of stop lamp switch or ASCD switch, if equipped (2) and brake pedal lever (3).	0.74 - 1.96 mm (0.0291 - 0.0772 in)
A	Pedal play	3 - 11 mm (0.12 - 0.43 in)

Check Valve

INFOID:000000001851336

Vacuum leakage [at vacuum of - 66.7 kPa (- 500 mmHg, - 19.69 inHg)]	Within 1.3 kPa (10 mmHg, 0.39 inHg) of vacuum for 15 seconds
--	--

Brake Booster

INFOID:000000001851337

Vacuum type

Vacuum leakage [at vacuum of - 66.7 kPa (- 500 mmHg, - 19.69 inHg)]	Within 1.3 kPa (10 mmHg, 0.39 inHg) of vacuum for 15 seconds
Input rod installation standard dimension	163.2 - 164.2 mm (6.43 - 6.46 in)

Dual Proportioning Valve

INFOID:000000001851338

Unit: kPa (kg/cm², psi)

Applied pressure (Front brake)	7,355 (75, 1,067)
Output pressure (Rear brake)	5,099 - 5,492 (52 - 56, 740 - 796)

Front Disc Brake

INFOID:000000001851339

CLZ25VF

SERVICE DATA AND SPECIFICATIONS (SDS)

< SERVICE INFORMATION >

Unit: mm (in)

Brake pad	Standard thickness (new)	11 (0.433)
	Repair limit thickness	2.0 (0.079)
Disc rotor	Standard thickness (new)	24.0 (0.945)
	Repair limit thickness	22.0 (0.866)
	Runout limit	0.035 (0.0014)
	Maximum uneven wear (measured at 8 positions)	0.02 mm (0.0008 in) or less

CLZ25VJ

Unit: mm (in)

Brake pad	Standard thickness (new)	11 (0.433)
	Repair limit thickness	2.0 (0.079)
Disc rotor	Standard thickness (new)	26.0 (1.024)
	Repair limit thickness	24.0 (0.945)
	Runout limit	0.035 (0.0014)
	Maximum uneven wear (measured at 8 positions)	0.02 mm (0.0008 in) or less

AD25V

Unit: mm (in)

Brake pad	Standard thickness (new)	11 (0.433)
	Repair limit thickness	2.0 (0.079)
Disc rotor	Standard thickness (new)	28.0 (1.102)
	Repair limit thickness	26.0 (1.024)
	Runout limit	0.035 (0.0014)
	Maximum uneven wear (measured at 8 positions)	0.02 mm (0.0008 in) or less

Rear Disc Brake

INFOID:000000001851340

Unit: mm (in)

Brake pad	Standard thickness (new)	8.5 (0.335)
	Repair limit thickness	2.0 (0.079)
Disc rotor	Standard thickness (new)	9.0 (0.354)
	Repair limit thickness	8.0 (0.315)
	Runout limit	0.07 (0.0028)
	Maximum uneven wear (measured at 8 positions)	0.015 mm (0.0006 in) or less

Rear Drum Brake

INFOID:000000001851341

Unit: mm (in)

Brake model	LT20D	
Brake lining	Standard thickness (new)	4.0 (0.157)
	Repair limit thickness	1.5 (0.059)
Drum	Standard inner diameter (new)	228.6 (9.000)
	Repair limit inner diameter	230.0 (9.055)