

SECTION **PB**
PARKING BRAKE SYSTEM

A
B
C
D
E
PB
G
H
I
J
K
L
M
N
O
P

CONTENTS

SERVICE INFORMATION	2	Component	5
PRECAUTIONS	2	Removal and Installation	5
Precaution for Supplemental Restraint System (SRS) "AIR BAG" and "SEAT BELT PRE-TEN- SIONER"	2	PARKING BRAKE SHOE	7
PREPARATION	3	Component	7
Commercial Service Tool	3	Removal and Installation	7
PARKING BRAKE CONTROL	4	Drum and Lining Break-in	9
On-Vehicle Service	4	SERVICE DATA AND SPECIFICATIONS (SDS)	10
		Parking Brake Control	10

PRECAUTIONS

< SERVICE INFORMATION >

SERVICE INFORMATION

PRECAUTIONS

Precaution for Supplemental Restraint System (SRS) "AIR BAG" and "SEAT BELT PRE-TENSIONER"

INFOID:000000001851342

The Supplemental Restraint System such as "AIR BAG" and "SEAT BELT PRE-TENSIONER", used along with a front seat belt, helps to reduce the risk or severity of injury to the driver and front passenger for certain types of collision. This system includes seat belt switch inputs and dual stage front air bag modules. The SRS system uses the seat belt switches to determine the front air bag deployment, and may only deploy one front air bag, depending on the severity of a collision and whether the front occupants are belted or unbelted. Information necessary to service the system safely is included in the SRS and SB section of this Service Manual.

WARNING:

- To avoid rendering the SRS inoperative, which could increase the risk of personal injury or death in the event of a collision which would result in air bag inflation, all maintenance must be performed by an authorized NISSAN/INFINITI dealer.
- Improper maintenance, including incorrect removal and installation of the SRS, can lead to personal injury caused by unintentional activation of the system. For removal of Spiral Cable and Air Bag Module, see the SRS section.
- Do not use electrical test equipment on any circuit related to the SRS unless instructed to in this Service Manual. SRS wiring harnesses can be identified by yellow and/or orange harnesses or harness connectors.

PREPARATION

< SERVICE INFORMATION >

PREPARATION

Commercial Service Tool

INFOID:000000001851343

Tool name	Description
<p data-bbox="167 352 277 380">Power tool</p> <p data-bbox="889 569 959 590">PBIC0190E</p> <p data-bbox="889 779 959 800">PBIC0191E</p>	<p data-bbox="1062 352 1393 380">Removing nuts, bolts and screws</p>

A
B
C
D
E
PB
G
H
I
J
K
L
M
N
O
P

PARKING BRAKE CONTROL

< SERVICE INFORMATION >

PARKING BRAKE CONTROL

On-Vehicle Service

INFOID:000000001851344

INSPECTION

When parking brake lever is operated with a force of 196 N (20 kg-f, 44 lb-f), make sure parking brake lever stroke is within the specified number of notches. (Check it by listening and counting ratchet clicks.)

Number of notches : 8 - 9

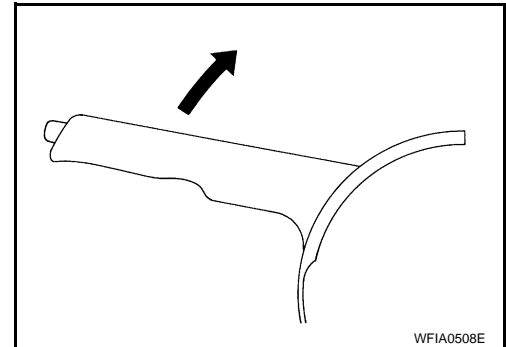

COMPONENTS INSPECTION

- Make sure that the mounting conditions (looseness, backlash, etc.) of each component are normal.
- Check the following:
 - Device assembly for bends, damage and cracks. Replace if any damage is noted.
 - Cables and equalizer for wear and damage. Replace if any damage is noted.
 - Parking brake switch. Replace if it does not work correctly.

ADJUSTMENT

1. Engage parking brake lever to access adjusting nut hole below grip.
2. Insert a deep socket wrench onto adjusting nut. Rotate adjusting nut to fully loosen cable, and then release parking brake lever.

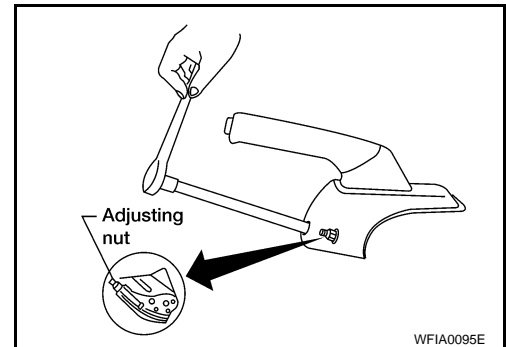

3. Depress the foot brake about 10 times and adjust the rear shoe clearance.
CAUTION:
Be sure to securely depress the foot brake.
4. Rotate brake drum or disc rotor to make sure that there is no drag.
5. Adjust parking brake cable with the following procedure.
 - a. When replace parking brake cable, operate parking brake lever with a force of 490 N (50 kg-f, 110 lb-f) about 10 times.
 - b. Engage parking brake lever to access adjusting nut hole below grip.
 - c. Rotate adjusting nut to adjust parking brake lever stroke using a deep socket wrench.
 - d. Operate parking brake lever with a force of 196 N (20 kg-f, 44 lb-f), make sure the parking brake lever stroke is within the specified number of notches. (Check it by listening and counting ratchet clicks.)
 - e. Make sure that there is no drag on rear brake or parking brake shoe with parking brake lever completely released.

PARKING BRAKE CONTROL

< SERVICE INFORMATION >

Component

INFOID:000000001851345

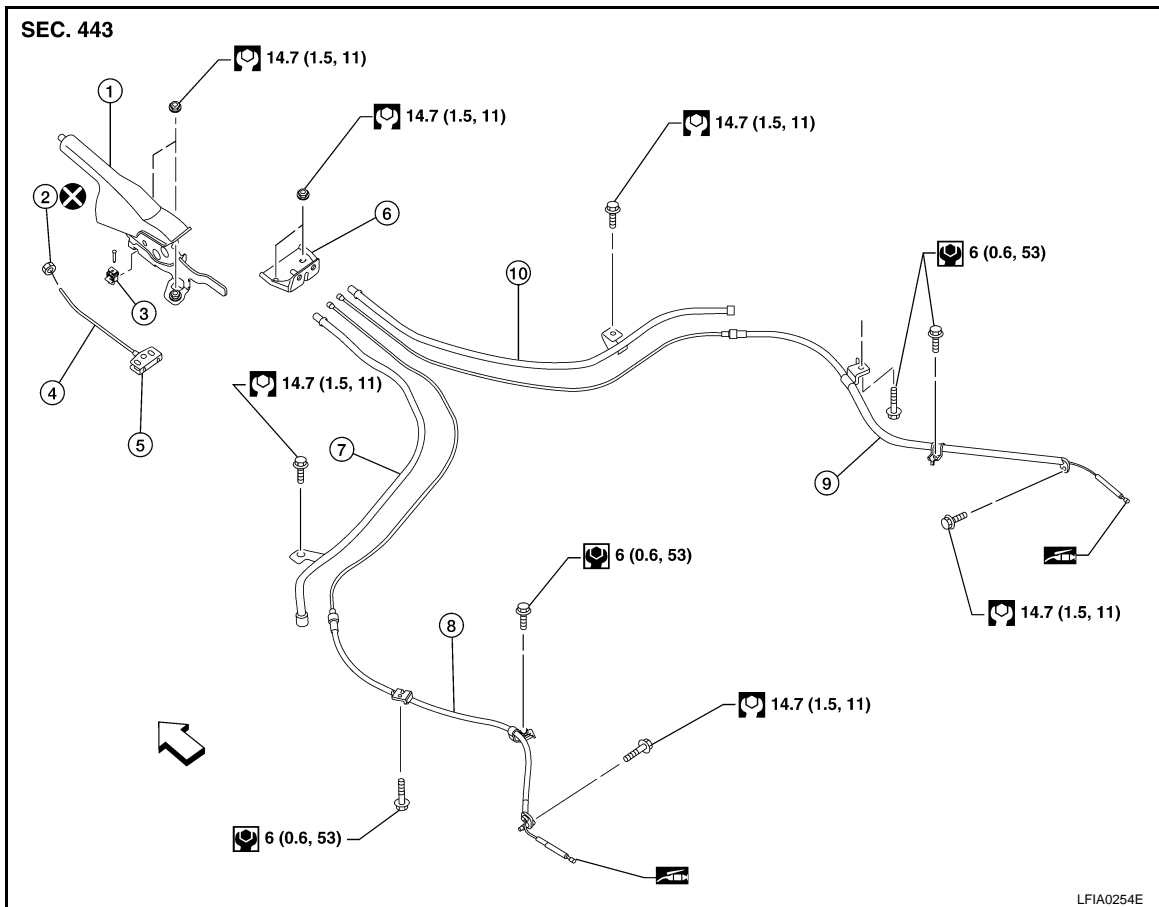

- | | | |
|--------------------|------------------------|-------------------------|
| 1. Device assembly | 2. Adjusting nut | 3. Parking brake switch |
| 4. Front cable | 5. Equalizer | 6. Bracket |
| 7. LH cable guide | 8. LH rear cable | 9. RH rear cable |
| 10. RH cable guide | : Multi-purpose grease | ← : Front |

Removal and Installation

INFOID:000000001851345

REMOVAL

1. Remove center console assembly. Refer to [IP-11, "Removal and Installation"](#).
2. Disconnect parking brake switch connector.
3. Loosen adjusting nut.
4. Remove equalizer from rear cable terminal ends.
5. Remove device assembly nuts, then remove device assembly.
6. Remove rear brake drum or disc rotor. Refer to [BR-34, "Removal and Installation of Drum Brake Assembly"](#) (brake drum), [BR-29, "Removal and Installation of Caliper Assembly"](#) (disc rotor).
7. Remove rear cables from the operating levers. Refer to [BR-34, "Removal and Installation of Drum Brake Assembly"](#) (drum brake), [PB-7, "Removal and Installation"](#) (disc brake).
8. Remove rear cable bolts, and then remove rear cables.
9. Remove bracket nuts and bracket.
10. Remove cable guide bolts and cable guides.
11. Remove adjusting nut and front cable from device assembly (if replacing front cable assembly).

INSTALLATION

1. Installation is in the reverse order of the removal. Tighten bolts and nuts to the specified torque.

PARKING BRAKE CONTROL

< SERVICE INFORMATION >

2. Adjust clearance of rear brake shoes. Refer to [PB-4. "On-Vehicle Service"](#).

PARKING BRAKE SHOE

< SERVICE INFORMATION >

PARKING BRAKE SHOE

Component

INFOID:000000001851347

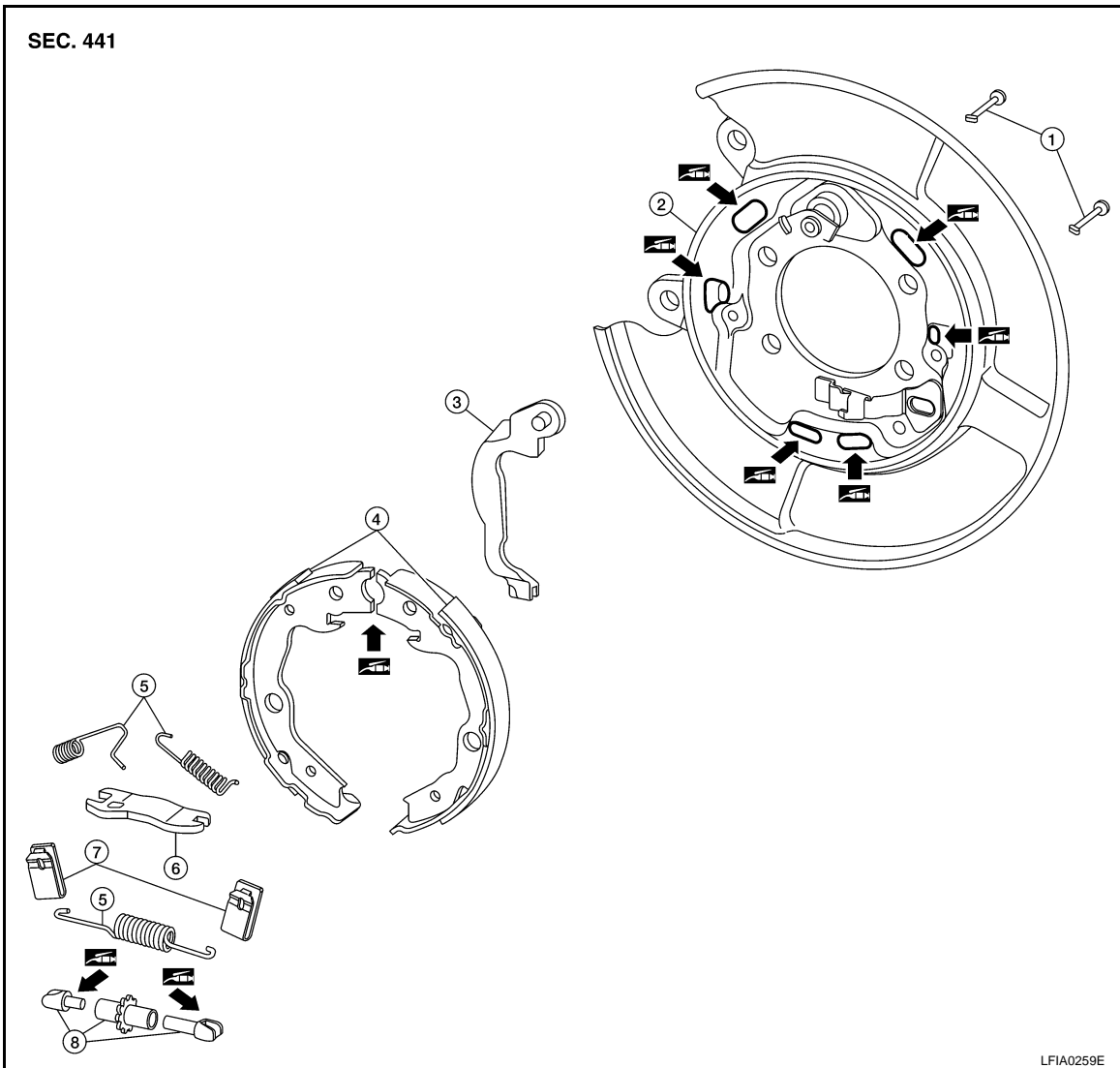

- | | | |
|--------------------|-----------------|----------|
| 1. Anchor pin | 2. Baffle plate | 3. Lever |
| 4. Brake shoe | 5. Spring | 6. Strut |
| 7. Retainer spring | 8. Adjuster | |

Removal and Installation

INFOID:000000001851348

REMOVAL

WARNING:

Clean brakes with a vacuum dust collector to minimize the hazard of airborne particles or other materials.

1. Remove wheel and tire.
2. Remove the brake rotor with the parking brake lever completely disengaged. If the brake rotor cannot be removed, remove as follows:

PARKING BRAKE SHOE

< SERVICE INFORMATION >

- Secure the brake rotor with the wheel nut and remove the adjuster hole plug.
- Insert a flat-bladed screwdriver or suitable tool through the plug opening and rotate the star wheel on the adjuster assembly in the direction as shown to retract the parking brake shoes.
- Remove the parking brake shoe springs.
- Remove retainer springs, parking brake shoes, strut, and adjuster. Then remove lever from brake shoe.

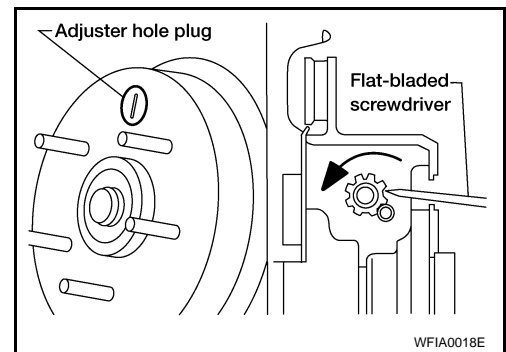

INSPECTION AFTER REMOVAL

- Visually inspect the lining for abnormal wear, damage and peeling.
- Using a micrometer, measure the thickness "A" of the lining.

Standard lining thickness : 3.2 mm (0.126 in)

Lining wear limit "A" : 1.5 mm (0.059 in)

- Visually inspect the inside of the drum for abnormal wear, damage and cracks. Using a pair of vernier calipers, measure the inside diameter of the drum.

Standard inner diameter : 172 mm (6.77 in)

Maximum inner diameter : 173 mm (6.81 in)

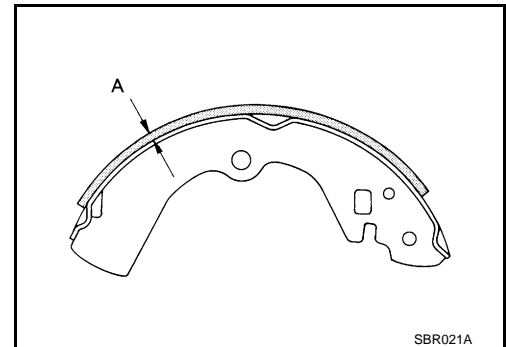

CAUTION:

If necessary, remove the parking brake shoe and check as follows.

- Check the shoe sliding surface for abnormal wear and damage.
- Check the anchor pin for abnormal wear and corrosion.
- Check the return springs for sagging.
- Check the adjuster for rough operation.

INSTALLATION

Installation is in the reverse order of removal.

- Apply brake grease to the contact areas on baffle plate. Refer to [MA-13](#).

- The orientation of the adjuster is different from LH to RH brakes. Assemble the adjuster so that the threaded part is expanded when rotating it in the direction as shown. Completely retract the adjuster to assemble. When disassembling the adjuster, apply brake grease to the threads. Refer to [MA-13](#).
- After installing parking brake shoes and rotor, adjust the parking brake. Refer to [PB-7, "Removal and Installation"](#).

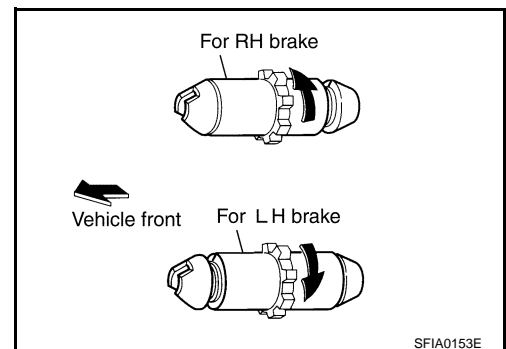

SHOE CLEARANCE ADJUSTMENT

- Make sure the parking brake control lever is fully released and parking brake cable adjusting nut is loosened.

PARKING BRAKE SHOE

< SERVICE INFORMATION >

- Remove the adjuster hole plug on the rotor. Using a screwdriver or suitable tool, turn the adjuster in the direction as shown until the rotor is locked. After locking, turn the adjuster in the opposite direction 5 or 6 notches.
- Rotate the rotor to make sure that there is no drag. Install the adjuster hole plug.
- After adjusting the clearance of the rear shoes, adjust the parking brake cable. Refer to [PB-4, "On-Vehicle Service"](#).
 - After replacing the shoes or the brake rotor or if the parking brake does not function well, perform the break-in procedure. Refer to [PB-9, "Drum and Lining Break-in"](#).

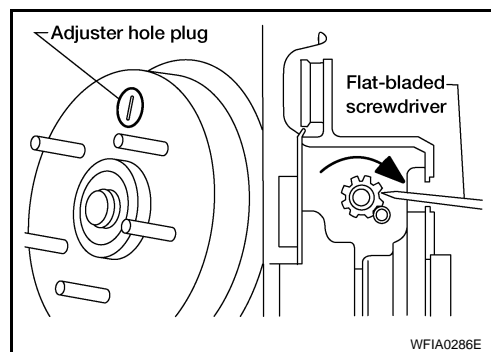

Drum and Lining Break-in

INFOID:000000001851349

CAUTION:

Do not carry out the break-in procedure excessively. Doing so may cause uneven or premature wear of the brake shoe lining.

When new parking brake shoes or brake rotors are installed or when parking brake performance is poor, perform the following break-in procedure.

- Drive the unloaded vehicle on a safe, level and dry road.
- Pull the parking brake control lever with a force of 147 N (15 kg-f, 33 lb-f).
- While pulling the lever, continue to drive the vehicle forward 100 meters (328 ft) at approximately 35 km/h (22 MPH).
- Allow the parking brake to cool down for approximately five minutes.
- Release the parking brake control lever and drive the vehicle under normal conditions for two minutes to cool down the parking brake.
- Repeat steps 1 through 5 three times and repeat just step 5 once more.
- After performing the break-in procedure, check the stroke of the parking brake control lever. If it is out of specification, adjust again. Refer to [PB-4, "On-Vehicle Service"](#).

SERVICE DATA AND SPECIFICATIONS (SDS)

< SERVICE INFORMATION >

SERVICE DATA AND SPECIFICATIONS (SDS)

Parking Brake Control

INFOID:000000001851350

Control type	Hand lever
Number of notches [under a force of 196 N (20 kg-f, 44 lb-f)]	8 – 9
Number of notches when warning lamp switch comes on	1