

A

ACC

# SECTION ACC

## ACCELERATOR CONTROL SYSTEM

C

### CONTENTS

D

E

<b>ACCELERATOR CONTROL SYSTEM</b> .....	<b>2</b>	<b>ASSEMBLY</b> .....	<b>3</b>	F
Removal and Installation .....	2	<b>SERVICE DATA AND SPECIFICATIONS (SDS)</b> .....	<b>5</b>	
ADJUSTABLE ACCELERATOR PEDAL		Accelerator Control .....	5	
ASSEMBLY .....	2	ACCELERATOR PEDAL STROKE AND		G
NON-ADJUSTABLE ACCELERATOR PEDAL		TRAVEL .....	5	

H

I

J

K

L

M

# ACCELERATOR CONTROL SYSTEM

PF18005

## ACCELERATOR CONTROL SYSTEM

### Removal and Installation ADJUSTABLE ACCELERATOR PEDAL ASSEMBLY

EBS00HZ0

#### Adjustable Accelerator Pedal

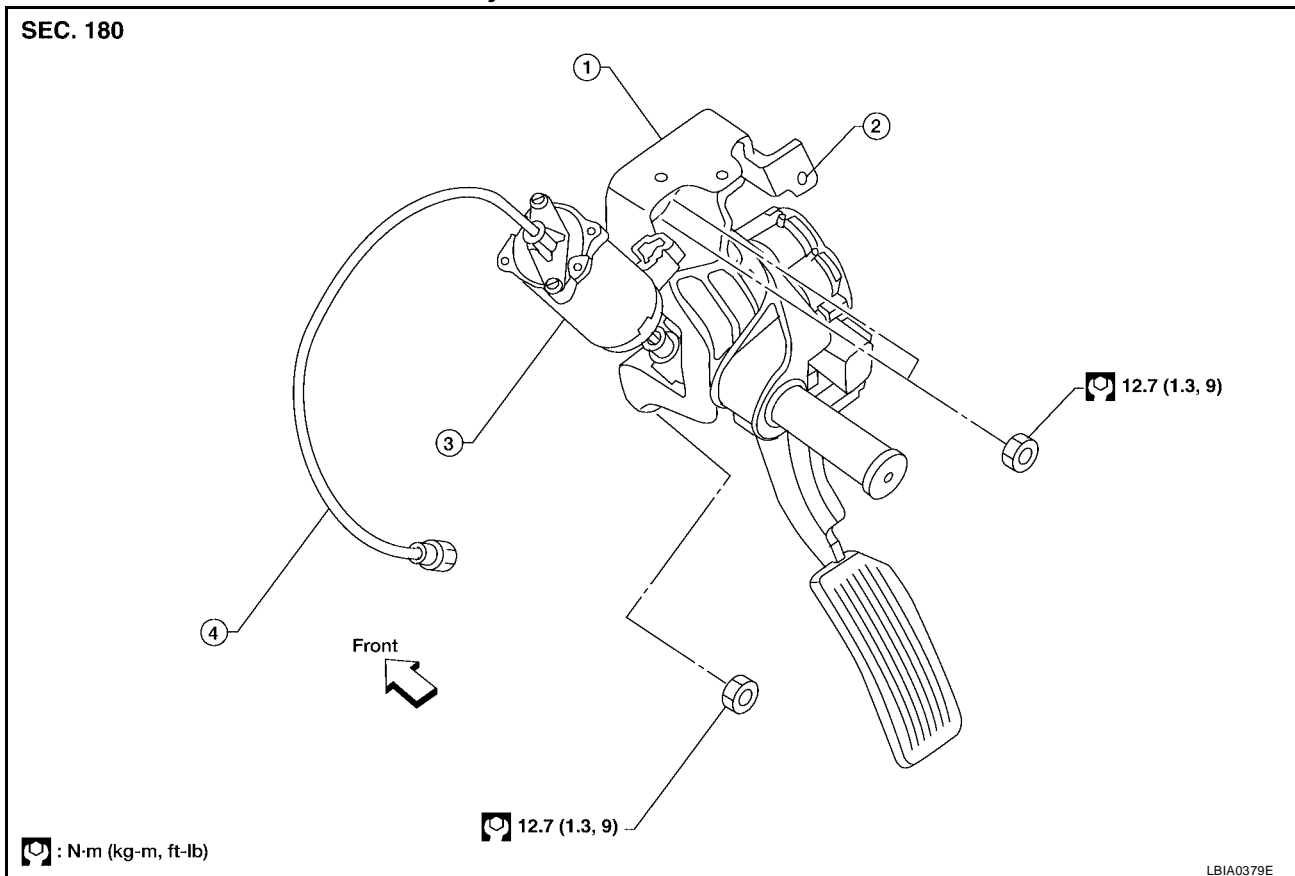

1. Adjustable accelerator pedal assembly
2. Adjustable accelerator pedal bracket (part of the accelerator pedal assembly)
3. Adjustable pedal electric motor (part of the accelerator pedal assembly)
4. Adjustable brake pedal cable (part of the accelerator pedal assembly)

#### CAUTION:

- Do not disassemble the accelerator pedal adjusting mechanism.
- Before removal and installation, the accelerator and brake pedals must be in the frontmost position. This is to align the base position of the accelerator and brake pedals.
- Do not disassemble the accelerator pedal assembly.
- Do not remove the accelerator pedal position sensor from the accelerator pedal bracket.
- Avoid damage from dropping the accelerator pedal assembly during handling.
- Keep the accelerator pedal assembly away from water.

#### Removal

1. Move the accelerator and brake pedals to the frontmost position.
2. Turn the ignition switch OFF and disconnect the negative battery terminal.
3. Disconnect the adjustable brake pedal cable from the adjustable brake pedal.
  - Unlock, then pull the adjustable brake pedal cable to disconnect it from the adjustable brake pedal.

# ACCELERATOR CONTROL SYSTEM

4. Disconnect the adjustable pedal electric motor electrical connector.
5. Disconnect the adjustable pedal electric motor memory electrical connector, if equipped.
6. Disconnect the accelerator position sensor electrical connector.
7. Remove the two upper and one lower accelerator pedal nuts.
8. Remove the adjustable accelerator pedal assembly.

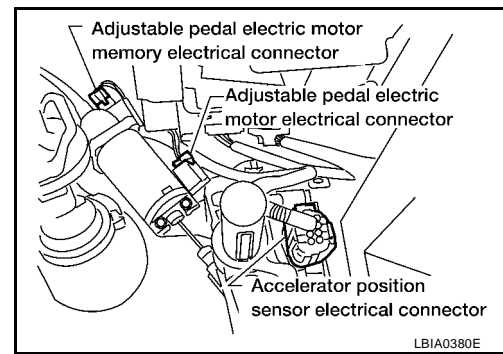

## Installation

Installation is in the reverse order of removal.

## Inspection After Installation

- Check that the accelerator pedal moves smoothly within the specified ranges.
  - Adjustable accelerator pedal – total pedal applied stroke : 48.3 mm (1.90 in)**
  - Adjustable accelerator pedal – total pedal adjustment travel : 73.2 mm (2.88 in)**
- Depress and release the accelerator pedal to check that it returns smoothly to the original released position.
- Perform an electrical inspection of the accelerator pedal position sensor. Refer to [EC-556, "DTC P2138 APP SENSOR"](#).

### CAUTION:

When the harness connector of the accelerator pedal position sensor is disconnected, perform "Accelerator Pedal Released Position Learning". Refer to [EC-44, "Accelerator Pedal Released Position Learning"](#).

## NON-ADJUSTABLE ACCELERATOR PEDAL ASSEMBLY

### Non-Adjustable Accelerator Pedal

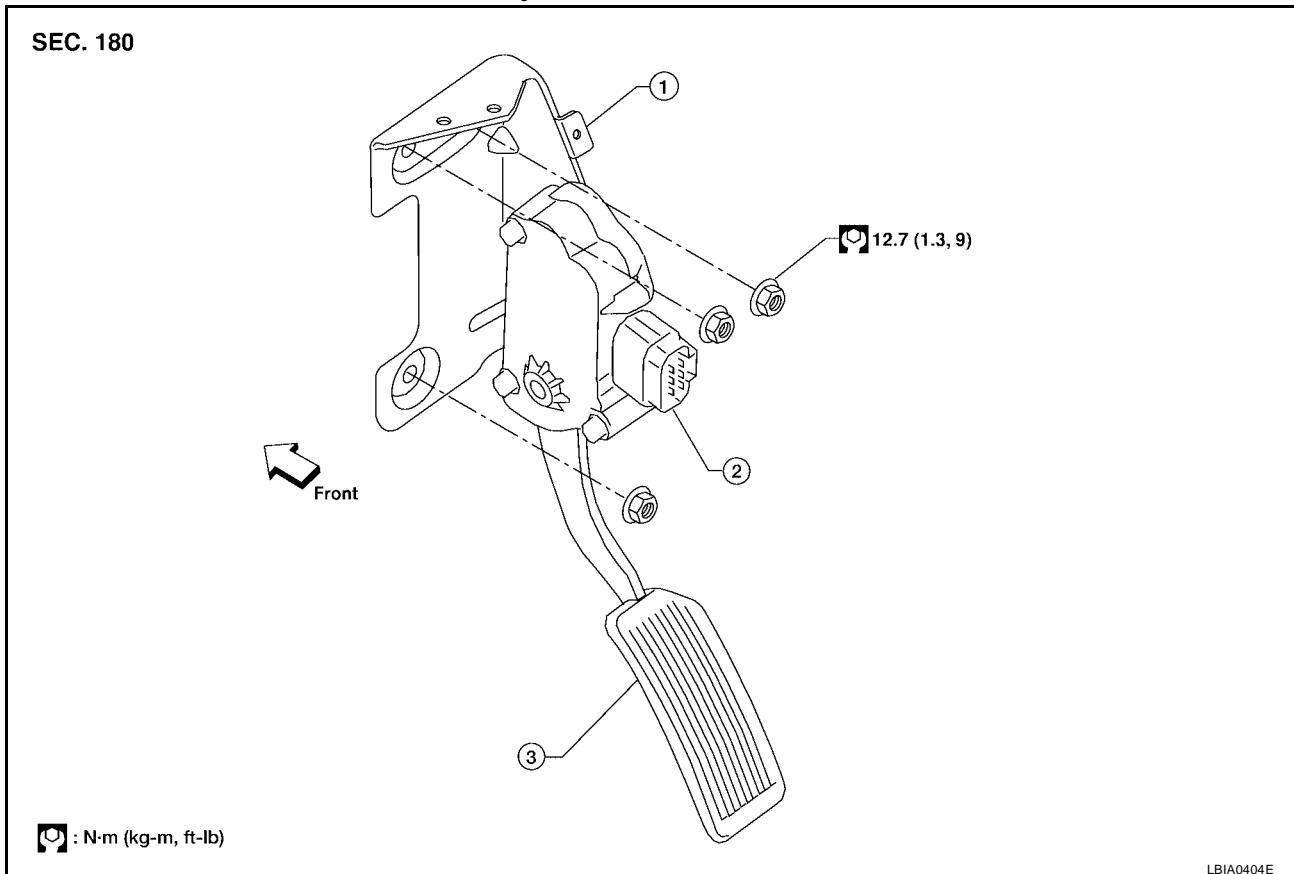

# ACCELERATOR CONTROL SYSTEM

---

1. Non-adjustable accelerator pedal A/T cable attachment bracket (part of the accelerator pedal assembly)
2. Non-adjustable accelerator pedal position sensor (part of the accelerator pedal assembly)
3. Non-adjustable accelerator pedal assembly

## CAUTION:

- Do not disassemble the accelerator pedal assembly.
- Do not remove the accelerator pedal position sensor from the accelerator pedal bracket.
- Avoid damage from dropping the accelerator pedal assembly during handling.
- Keep the accelerator pedal assembly away from water.

## Removal

1. Turn the ignition switch OFF and disconnect the negative battery terminal.
2. Disconnect the accelerator position sensor electrical connector.
3. Remove the two upper and one lower accelerator pedal nuts.
4. Remove the adjustable accelerator pedal assembly.

## Installation

Installation is in the reverse order of removal.

## Inspection After Installation

- Check that the accelerator pedal moves smoothly within the specified range.  
**Non-adjustable accelerator pedal – total pedal applied stroke : 48 mm (1.89 in)**
- Depress and release the accelerator pedal to check that it returns smoothly to the original released position.
- Perform an electrical inspection of the accelerator pedal position sensor. Refer to [EC-556, "DTC P2138 APP SENSOR"](#).

## CAUTION:

**When the harness connector of the accelerator pedal position sensor is disconnected, perform "Accelerator Pedal Released Position Learning". Refer to [EC-44, "Accelerator Pedal Released Position Learning"](#).**

# SERVICE DATA AND SPECIFICATIONS (SDS)

## SERVICE DATA AND SPECIFICATIONS (SDS)

PFP:00030

### Accelerator Control

EBS00HZP

### ACCELERATOR PEDAL STROKE AND TRAVEL

Unit: mm (in)

Non-adjustable accelerator pedal - total pedal applied stroke	48 (1.89)
Adjustable accelerator pedal - total pedal applied stroke	48.3 (1.90)
Adjustable accelerator pedal - total pedal adjustment travel	73.2 (2.88)

A

ACC

C

D

E

F

G

H

I

J

K

L

M

# SERVICE DATA AND SPECIFICATIONS (SDS)

---