

SECTION **BR**
BRAKE SYSTEM

A
B
C
D
E

CONTENTS

PRECAUTIONS	3	DISASSEMBLY AND ASSEMBLY	16
Precautions for Supplemental Restraint System (SRS) "AIR BAG" and "SEAT BELT PRE-TENSIONER"	3	With ABLs or VDC	16
Precautions for Brake System	3	REMOVAL AND INSTALLATION	17
PREPARATION	4	DISASSEMBLY AND ASSEMBLY	17
Special Service Tool	4	BRAKE BOOSTER	18
Commercial Service Tools	4	On-Vehicle Service	18
NOISE, VIBRATION, AND HARSHNESS (NVH)		OPERATING CHECK	18
TROUBLESHOOTING	5	AIRTIGHT CHECK	18
NVH Troubleshooting Chart	5	With ABS or BLSD	19
BRAKE PEDAL	6	REMOVAL	19
Inspection and Adjustment	6	INSPECTION AFTER REMOVAL	19
INSPECTION	6	INSTALLATION	20
ADJUSTMENT	6	With VDC	20
Removal and Installation	7	REMOVAL	20
REMOVAL	8	INSPECTION AFTER REMOVAL	21
INSPECTION AFTER REMOVAL	9	INSTALLATION	21
INSTALLATION	9	VACUUM LINES	22
BRAKE FLUID	10	Removal and Installation	22
On-board Inspection	10	Inspection	22
LEVEL CHECK	10	VISUAL INSPECTION	22
Drain and Refill	10	CHECK VALVE INSPECTION	22
Bleeding Brake System	11	FRONT DISC BRAKE	23
BRAKE PIPING AND HOSE	12	On-vehicle Inspection	23
Hydraulic Circuit	12	PAD WEAR INSPECTION	23
Removal and Installation of Front Brake Piping and Brake Hose	12	Components	23
REMOVAL	12	Removal and Installation of Brake Pad	24
INSTALLATION	13	REMOVAL	24
Removal and Installation of Rear Brake Piping and Brake Hose	13	INSTALLATION	24
REMOVAL	13	Removal and Installation of Brake Caliper Assembly and Disc Rotor	24
INSTALLATION	13	REMOVAL	24
Inspection After Installation	14	INSTALLATION	24
BRAKE MASTER CYLINDER	15	Disassembly and Assembly of Brake Caliper Assembly	25
On-board Inspection	15	DISASSEMBLY	25
LEAK INSPECTION	15	CALIPER INSPECTION	26
With ABS	15	ASSEMBLY	26
REMOVAL AND INSTALLATION	15	DISC ROTOR INSPECTION	27
		BRAKE BURNISHING PROCEDURE	27
		REAR DISC BRAKE	28

BR
G
H
I
J
K
L
M

On-vehicle Inspection	28	Assembly	31
PAD WEAR INSPECTION	28	DISASSEMBLY	31
Components	28	CALIPER INSPECTION	31
Removal and Installation of Brake Pad	29	ASSEMBLY	31
REMOVAL	29	DISC ROTOR INSPECTION	32
INSTALLATION	29	BRAKE BURNISHING PROCEDURE	33
Removal and Installation of Brake Caliper Assembly		SERVICE DATA AND SPECIFICATIONS (SDS)	34
and Disc Rotor	29	General Specifications	34
REMOVAL	29	Brake Pedal	34
INSTALLATION	29	Brake Booster	34
Disassembly and Assembly of Brake Caliper		Check Valve	34
		Front Disc Brake	34
		Rear Disc Brake	35

PRECAUTIONS

PRECAUTIONS

PFP:00001

Precautions for Supplemental Restraint System (SRS) "AIR BAG" and "SEAT BELT PRE-TENSIONER"

EFS003NW

The Supplemental Restraint System such as "AIR BAG" and "SEAT BELT PRE-TENSIONER", used along with a front seat belt, helps to reduce the risk or severity of injury to the driver and front passenger for certain types of collision. This system includes seat belt switch inputs and dual stage front air bag modules. The SRS system uses the seat belt switches to determine the front air bag deployment, and may only deploy one front air bag, depending on the severity of a collision and whether the front occupants are belted or unbelted. Information necessary to service the system safely is included in the SRS and SB section of this Service Manual.

WARNING:

- To avoid rendering the SRS inoperative, which could increase the risk of personal injury or death in the event of a collision which would result in air bag inflation, all maintenance must be performed by an authorized NISSAN/INFINITI dealer.
- Improper maintenance, including incorrect removal and installation of the SRS, can lead to personal injury caused by unintentional activation of the system. For removal of Spiral Cable and Air Bag Module, see the SRS section.
- Do not use electrical test equipment on any circuit related to the SRS unless instructed to in this Service Manual. SRS wiring harnesses can be identified by yellow and/or orange harnesses or harness connectors.

Precautions for Brake System

EFS003NX

- Refer to [MA-11, "RECOMMENDED FLUIDS AND LUBRICANTS"](#) for recommended brake fluid.
- Do not reuse drained brake fluid.
- Be careful not to splash brake fluid on painted areas.
- To clean or wash all parts of master cylinder, disc brake caliper and wheel cylinder, use clean brake fluid.
- Do not use mineral oils such as gasoline or kerosene. They will ruin rubber parts of the hydraulic system.
- Use flare nut wrench when removing and installing brake tube.
- Always check tightening torque when installing brake lines.
- Before working, turn ignition switch to OFF and disconnect connectors for ABS actuator and electric unit (control unit) or battery terminals.
- Burnish the brake contact surfaces after refinishing or replacing drums or rotors, after replacing pads or linings, or if a soft pedal occurs at very low mileage. Refer to [BR-27, "BRAKE BURNISHING PROCEDURE"](#).

WARNING:

- Clean brake pads and shoes with a waste cloth, then wipe with a dust collector.

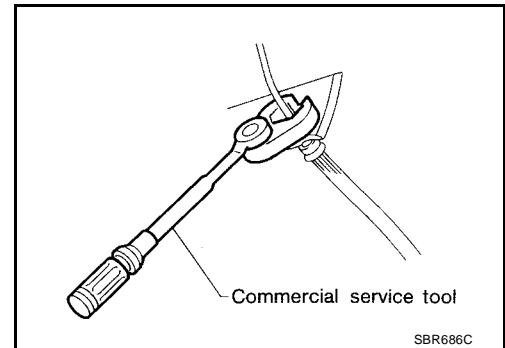

PREPARATION

PREPARATION

PFP:00002

Special Service Tool

EFS005TU

The actual shapes of Kent-Moore tools may differ from those of special service tools illustrated here.

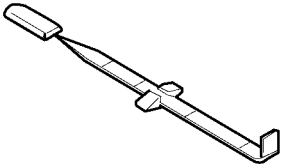
Tool number (Kent-Moore No.) Tool name	Description
<p>— (J-46532) Brake and clutch pedal height measurement tool</p>  <p style="text-align: right; font-size: small;">LFIA0227E</p>	<p>Measuring brake pedal height</p>

Commercial Service Tools

EFS005TV

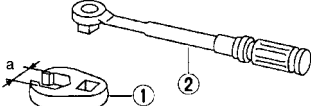
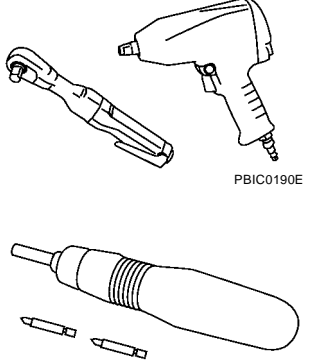
Tool name	Description
<p>1. Flare nut crowfoot 2. Torque wrench</p>  <p style="text-align: right; font-size: small;">S-NT360</p>	<p>Removing and installing each brake piping. a: 10 mm (0.39 in) / 12 mm (0.47 in)</p>
<p>Power tool</p>  <p style="text-align: right; font-size: small;">PBIC0190E PBIC0191E</p>	<p>Removing nuts, bolts and screws.</p>

BRAKE PEDAL

BRAKE PEDAL

PFP:46501

Inspection and Adjustment INSPECTION

EF500300

1. Inspect the brake pedal free height "H" from the lower dash panel using tool.

Tool number : — (J-46532)

2. Adjust the height referring to the following specifications.

CAUTION:

When equipped with adjustable pedal, the pedal must be in the forwardmost (closest to the floor) position for pedal height measurement.

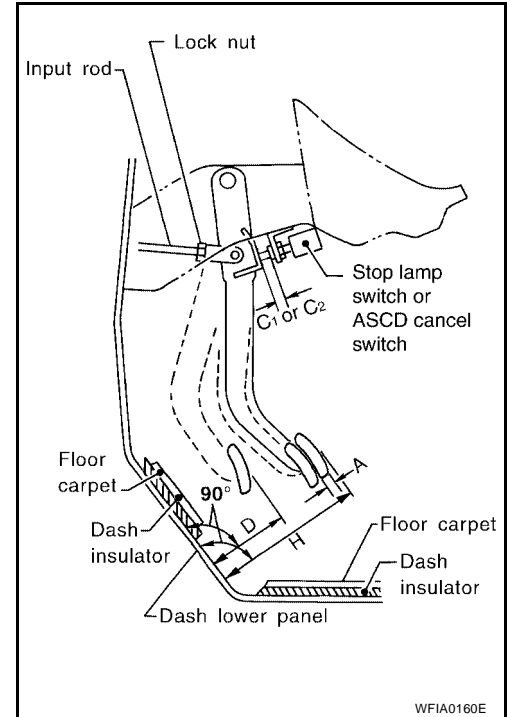

Brake Pedal Specifications

Free height "H"	: 182.3 - 192.3 mm (7.18 - 7.57 in)
Depressed pedal height "D" [under a force of 490 N (50 kg, 110 lb) with engine running]	: More than 90.3 mm (3.55 in)
Clearance between pedal stopper and threaded end of stop lamp switch and ASCD switch "C1 " or "C2 "	: 0.74 - 1.96 mm (0.029 - 0.077 in)
Pedal play "A"	: 3 - 11 mm (0.12 - 0.43 in)

ADJUSTMENT

1. Loosen the stop lamp switch and ASCD switch by turning 45° counterclockwise.

BRAKE PEDAL

- Loosen lock nut on the input rod, then turn input rod to adjust the pedal to specified height. When finished adjusting, tighten lock nut.

CAUTION:

Make sure that the screw portion of the end of input rod is located inside the clevis.

Lock nut : 18.5 N·m (1.9 kg-m, 14 ft-lb)

- With the pedal pulled up and held by hand, press the stop lamp switch and the ASCD switch in until threaded ends contact pedal arm.
- With the threaded ends of the stop lamp switch and ASCD switch contacting the pedal arm, turn the switches 45° clockwise to lock in place.

CAUTION:

Make sure that the gap (C) between the rubber stops and switch ends are within specification.

- Check the pedal play.

CAUTION:

Make sure that the stop lamp goes off when the pedal is released.

- Start the engine and check the height of the brake pedal when depressing it.

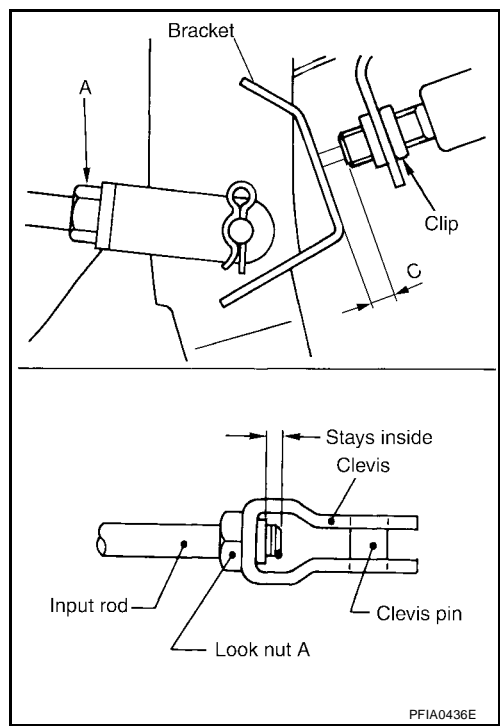

A
B
C
D
E
BR
G

EFS00301

Removal and Installation

Non-Adjustable Pedals

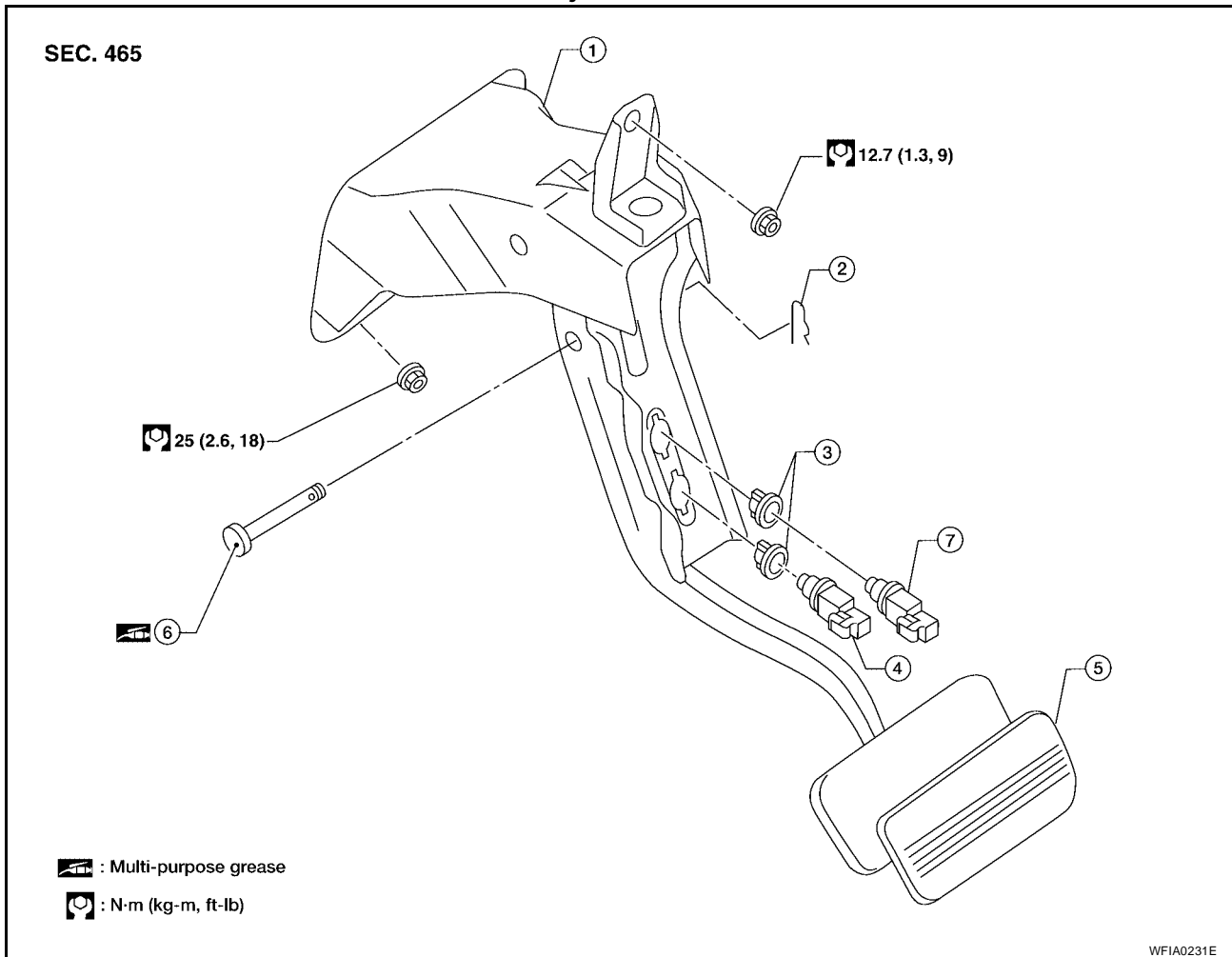

H
I
J
K
L
M

BRAKE PEDAL

- | | | |
|-------------------------|--------------|---------------|
| 1. Brake pedal assembly | 2. Snap pin | 3. Clip |
| 4. Stop lamp switch | 5. Pedal pad | 6. Clevis pin |
| 7. ASCD cancel switch | | |

Adjustable Pedals

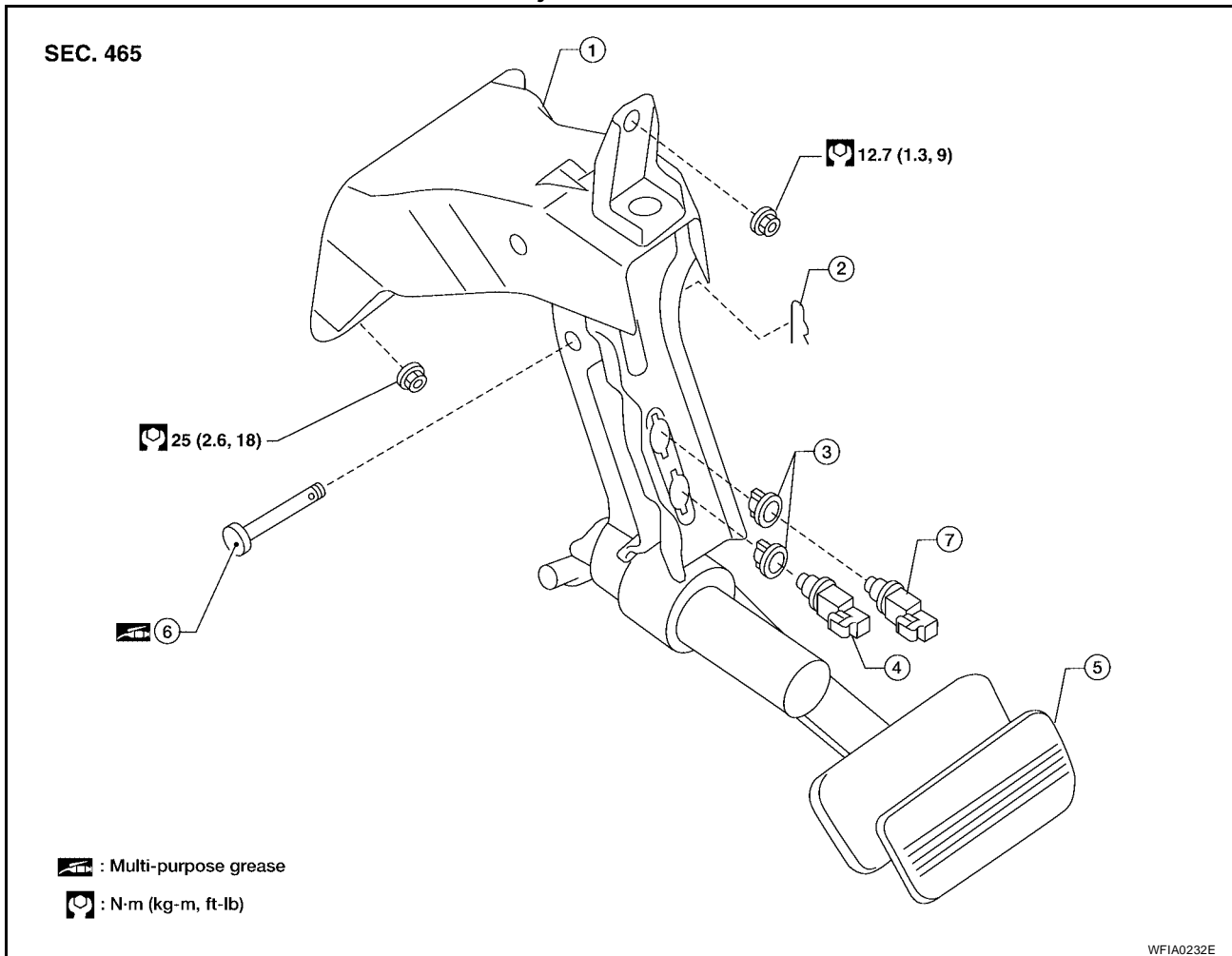

- | | | |
|-------------------------|--------------|---------------|
| 1. Brake pedal assembly | 2. Snap pin | 3. Clip |
| 4. Stop lamp switch | 5. Pedal pad | 6. Clevis pin |
| 7. ASCD cancel switch | | |

REMOVAL

WARNING:

Do not deform the brake tube.

CAUTION:

- Before removal and installation the accelerator and brake pedals must be in the forwardmost position (closest to the floor). This is to align the base position of the accelerator and brake pedals (adjustable type only).
 - Do not disassemble the brake pedal adjusting mechanism (adjustable type only).
 - Avoid damage from dropping the brake pedal assembly during handling.
 - Keep the brake pedal assembly away from water.
1. Remove the lower driver instrument panel. Refer to [IP-13, "LOWER INSTRUMENT PANEL LH"](#).
 2. Remove the stop lamp switch and ASCD switch from the pedal assembly.

BRAKE PEDAL

3. On adjustable pedal assembly, disconnect the adjustable brake pedal cable from the adjustable pedal electric motor.
 - Unlock (1) then pull (2) the adjustable brake pedal cable to disconnect it from the adjustable pedal electric motor as shown.
4. Remove snap pin and clevis pin from the clevis of brake booster.
5. Remove mounting nuts and the pedal assembly.
 - Temporarily install nuts by hand to support booster.

CAUTION:

- Before removal and installation the accelerator and brake pedals must be in the forwardmost position (closest to the floor). This is to align the base position of the accelerator and brake pedals (adjustable type only).
- Do not disassemble the brake pedal adjusting mechanism (adjustable type only).
- Avoid damage from dropping the brake pedal assembly during handling.
- Keep the brake pedal assembly away from water.

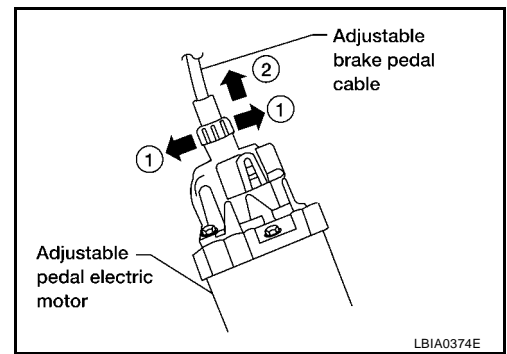

INSPECTION AFTER REMOVAL

Check brake pedal for following items.

- Crack or deformation of clevis pin stopper
- Clevis pin deformation
- Crack of any welded portion
- Brake pedal bend

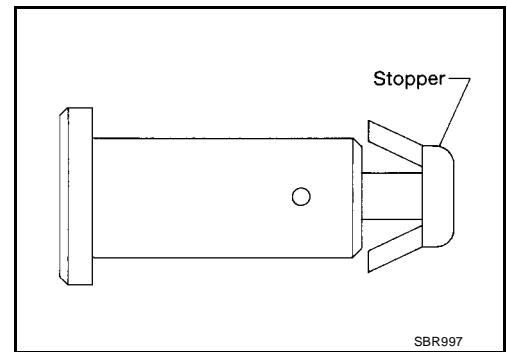

INSTALLATION

1. Installation is in the reverse order of removal.
 - Check the brake pedal for smooth operation. There should be no binding or sticking when applying or releasing the brake pedal.
 - Check the brake pedal adjustable feature for smooth operation. There should be no binding or sticking when adjusting the brake pedal forward or backward.
- After installing the brake pedal assembly in the vehicle, be sure to adjust it. Refer to [BR-6, "Inspection and Adjustment"](#).

BRAKE FLUID

PFK:KN100

BRAKE FLUID

On-board Inspection LEVEL CHECK

EFS00302

- Make sure the fluid level in reservoir tank is within the standard (between MAX and MIN lines).
- Visually check around reservoir tank for fluid leaks.
- If fluid level is excessively low, check brake system for leaks.
- If brake warning lamp remains illuminated after parking lever is released, check brake system for fluid leakage.

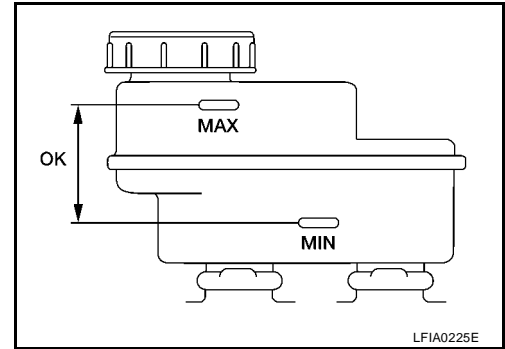

Drain and Refill

EFS00303

CAUTION:

- Refill with new brake fluid. Refer to [MA-11, "RECOMMENDED FLUIDS AND LUBRICANTS"](#).
 - Do not reuse drained brake fluid.
 - Do not let brake fluid splash on the painted surfaces of the body. This might damage the paint, so when splashing it, immediately wipe off the area and wash away with water.
 - Before servicing, disconnect actuator connector or battery negative cable.
1. Connect a vinyl tube to each bleed valve.
 2. Depress brake pedal, loosen each bleed valve, and gradually remove brake fluid.

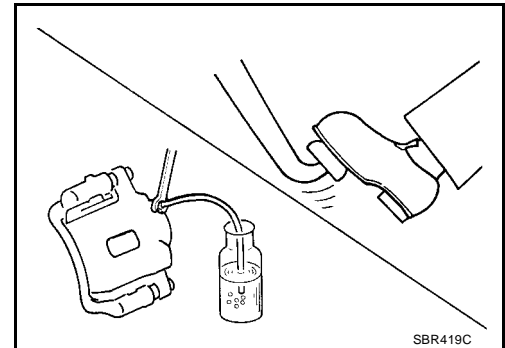

3. Make sure there is no foreign material in reservoir tank, and refill with new brake fluid.
4. Rest foot on brake pedal. Loosen bleed valve. Slowly depress pedal until it stops. Tighten bleed valve. Release brake pedal. Repeat this process a few times, then pause to add new brake fluid to master cylinder. Continue until new brake fluid flows out. Bleed air. Refer to [BR-11, "Bleeding Brake System"](#).

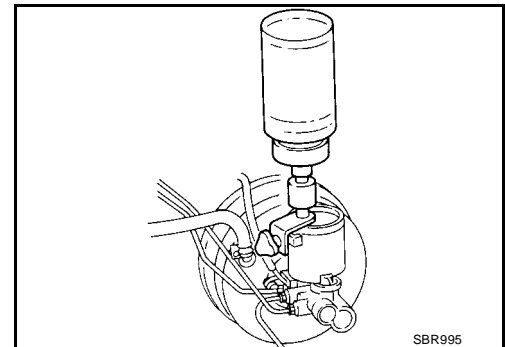

BRAKE FLUID

Bleeding Brake System

EFS00304

CAUTION:

While bleeding, pay attention to master cylinder fluid level.

1. Turn ignition switch OFF and disconnect ABS actuator and electric unit (control unit) connector or battery negative cable.
2. Connect a vinyl tube to the rear right bleed valve.
3. Fully depress brake pedal 4 to 5 times.
4. With brake pedal depressed, loosen bleed valve to let the air out, and then tighten it immediately.
5. Repeat steps 3, 4 until no more air comes out.
6. Tighten bleed valve to the specified torque. Refer to [BR-23, "Components"](#) (front disc brake), [BR-28, "Components"](#) (rear disc brake).
7. Repeat steps 2 through 6, with master cylinder reservoir tank filled at least half way, bleeding air in order from the front left, rear left, and front right bleed valves.

A

B

C

D

E

BR

G

H

I

J

K

L

M

BRAKE PIPING AND HOSE

BRAKE PIPING AND HOSE

PF0:46210

Hydraulic Circuit

EFS00305

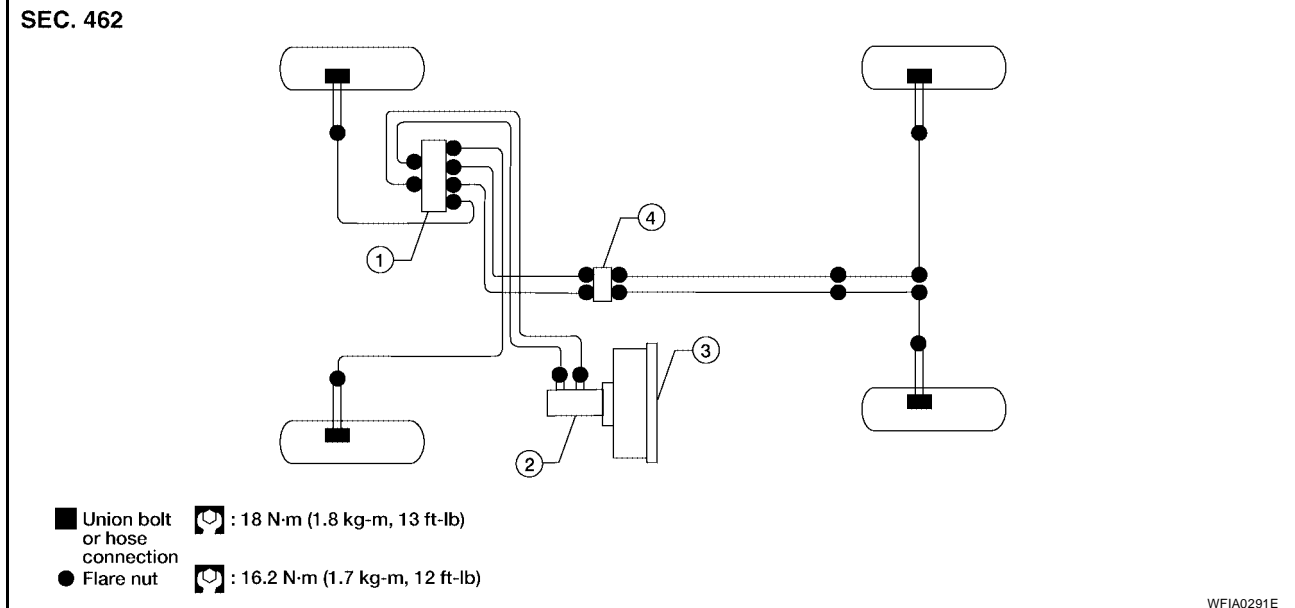

1. Actuator
2. Master cylinder
3. Brake booster
4. Connector

CAUTION:

- All hoses and piping (tubes) must be free from excessive bending, twisting and pulling.
- Make sure there is no interference with other parts when turning steering both clockwise and counterclockwise.
- The brake piping is an important safety part. If a brake fluid leak is detected, always disassemble the parts. Replace applicable part with a new one, if necessary.
- Be careful not to splash brake fluid on painted areas; it may cause paint damage. If brake fluid is splashed on painted areas, wash it away with water immediately.
- Do not bend or twist brake hose sharply, or strongly pull it.
- When removing components, cover connections so that no dirt, dust, or other foreign matter gets in.
- Refill with new brake fluid. Refer to [MA-11, "RECOMMENDED FLUIDS AND LUBRICANTS"](#).
- Do not reuse drained brake fluid.

Removal and Installation of Front Brake Piping and Brake Hose

EFS00306

REMOVAL

1. Drain brake fluid. Refer to [BR-10, "Drain and Refill"](#).
2. Using a flare nut wrench, remove brake tube from brake hose.
3. Remove lock plate and brake hose from bracket.
4. Remove union bolt and then remove brake hose from caliper assembly.

BRAKE PIPING AND HOSE

INSTALLATION

1. Install brake hose by aligning with the protrusion on caliper assembly, then install the union bolt.

NOTE:

Do not reuse copper washer.

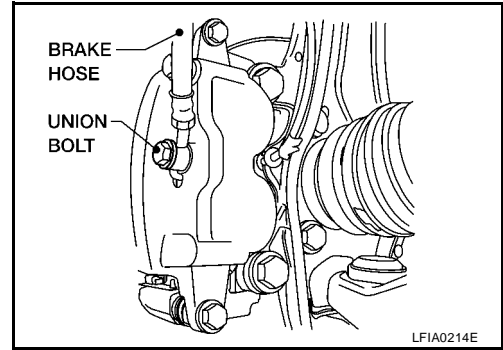

2. Insert brake hose end through bracket, then secure it to bracket with lock plate.
3. Install brake tube to brake hose, then tighten the flare nut using a flare nut wrench.
4. Refill brake fluid and bleed air. Refer to [BR-11, "Bleeding Brake System"](#).

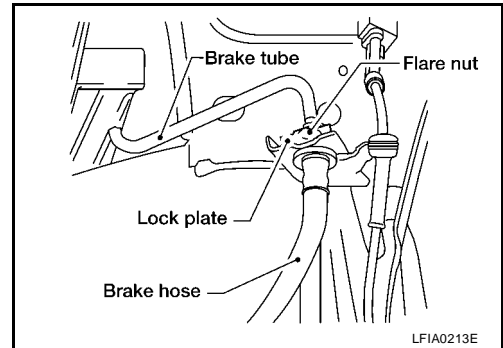

Removal and Installation of Rear Brake Piping and Brake Hose

EFS00307

REMOVAL

1. Drain brake fluid. Refer to [BR-10, "Drain and Refill"](#).
2. Using a flare nut wrench, remove brake tube from brake hose.
3. Remove lock plate and brake hose from bracket.
4. Remove brake hose from caliper assembly.

INSTALLATION

1. Install brake hose to caliper assembly.

NOTE:

Do not reuse copper washer.

2. Insert brake hose end through bracket, then secure it to bracket with lock plate.
3. Install brake tube to brake hose, then tighten the flare nut using a flare nut wrench.
4. Refill brake fluid and bleed air. Refer to [BR-11, "Bleeding Brake System"](#).

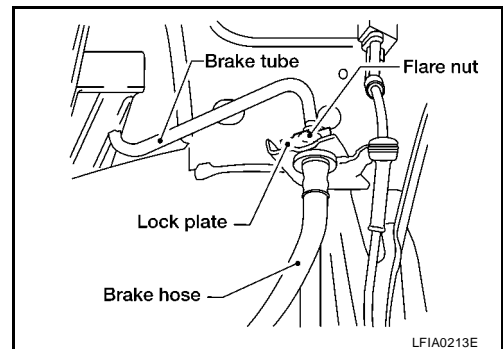

BRAKE PIPING AND HOSE

Inspection After Installation

EFS00308

CAUTION:

If a leak is detected at the connections, retighten it or, if necessary, replace the damaged part.

1. Check brake lines (tubes and hoses), and connections for fluid leaks, damage, twist, deformation, contact with other parts, and loose connections. Replace any damage parts.
2. While depressing brake pedal under a force of 785 N (80 kg, 177 lb) with engine running for approximately 5 seconds, check for fluid leakage from each part.

BRAKE MASTER CYLINDER

PFP:46010

BRAKE MASTER CYLINDER

On-board Inspection LEAK INSPECTION

EFS00309

- Check for leaks at master cylinder to brake booster attachment point, reservoir tank, and brake tube connections.

With ABS

EFS0030A

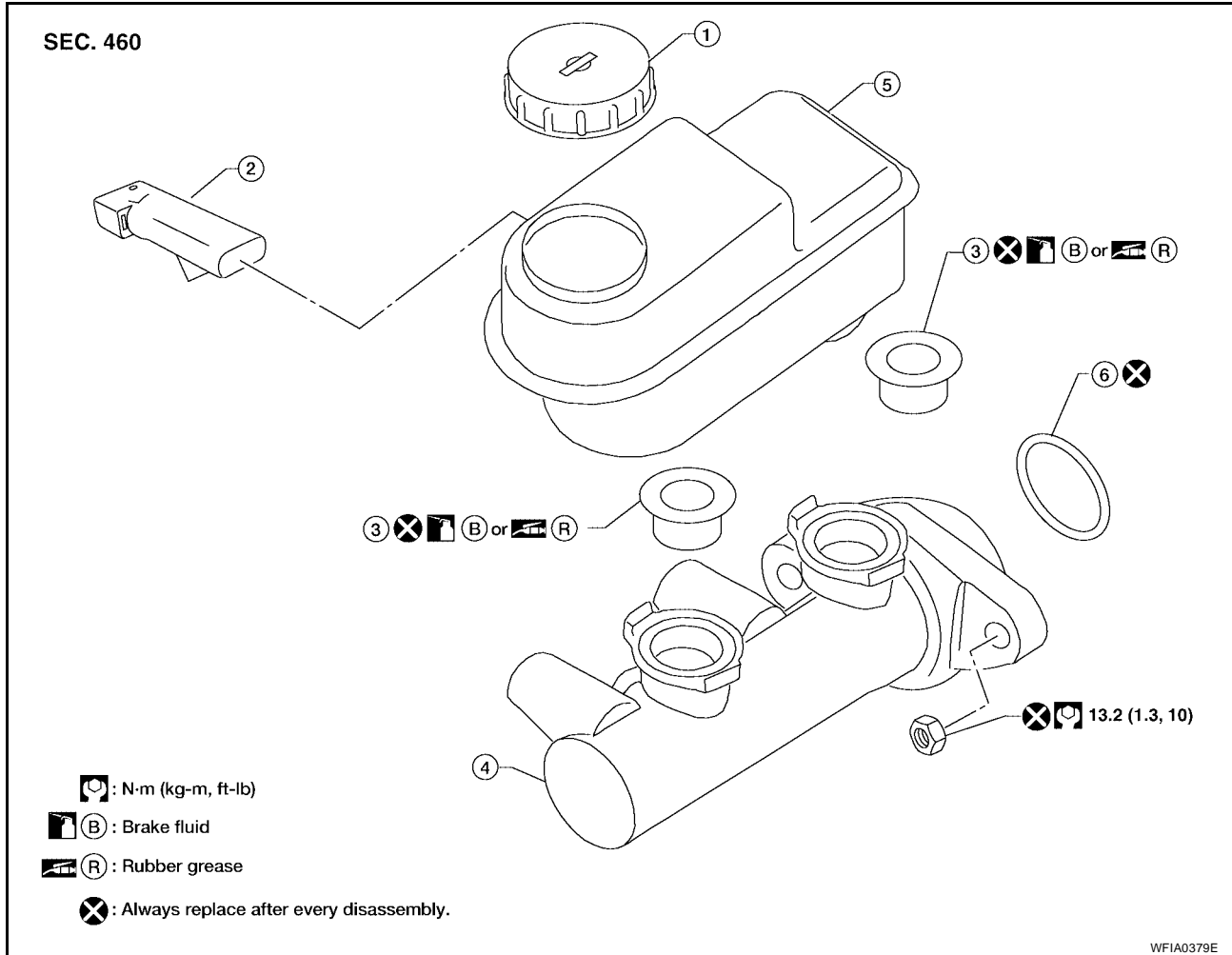

CAUTION:

Be careful not to splash brake fluid on painted areas; it may cause paint damage. If brake fluid is splashed on painted areas, wash it away with water immediately.

REMOVAL AND INSTALLATION

Removal

1. Drain brake fluid. Refer to [BR-10, "Drain and Refill"](#).
2. Disconnect harness connector for fluid level sensor.
3. Using a flare nut wrench, disconnect brake tube from master cylinder assembly.
4. Remove master cylinder assembly mounting nuts and master cylinder assembly.

Installation

Installation is in the reverse order of removal.

- Refill brake fluid and bleed air. Refer to [BR-11, "Bleeding Brake System"](#).

BRAKE MASTER CYLINDER

CAUTION:

- Refill with recommended brake fluid. Refer to [MA-11, "RECOMMENDED FLUIDS AND LUBRICANTS"](#).
- Do not reuse drained brake fluid.
- Adjust brake pedal. Refer to [BR-6, "ADJUSTMENT"](#).

DISASSEMBLY AND ASSEMBLY

Disassembly

CAUTION:

- Master cylinder cannot be disassembled.
- Remove reservoir tank only when absolutely necessary.

Pull reservoir tank off master cylinder sub-assembly, then remove grommets from master cylinder sub-assembly body.

Assembly

CAUTION:

- Never use mineral oil such as kerosene or gasoline during the cleaning and assembly process.
 - Do not drop parts. If a part is dropped, do not use it.
1. Apply brake fluid or rubber grease to new grommets, then insert into master cylinder sub-assembly. Refer to [MA-11, "RECOMMENDED FLUIDS AND LUBRICANTS"](#).

CAUTION:

Do not reuse grommet.

2. Install reservoir tank onto master cylinder assembly.

With ABLs or VDC

EFS004BA

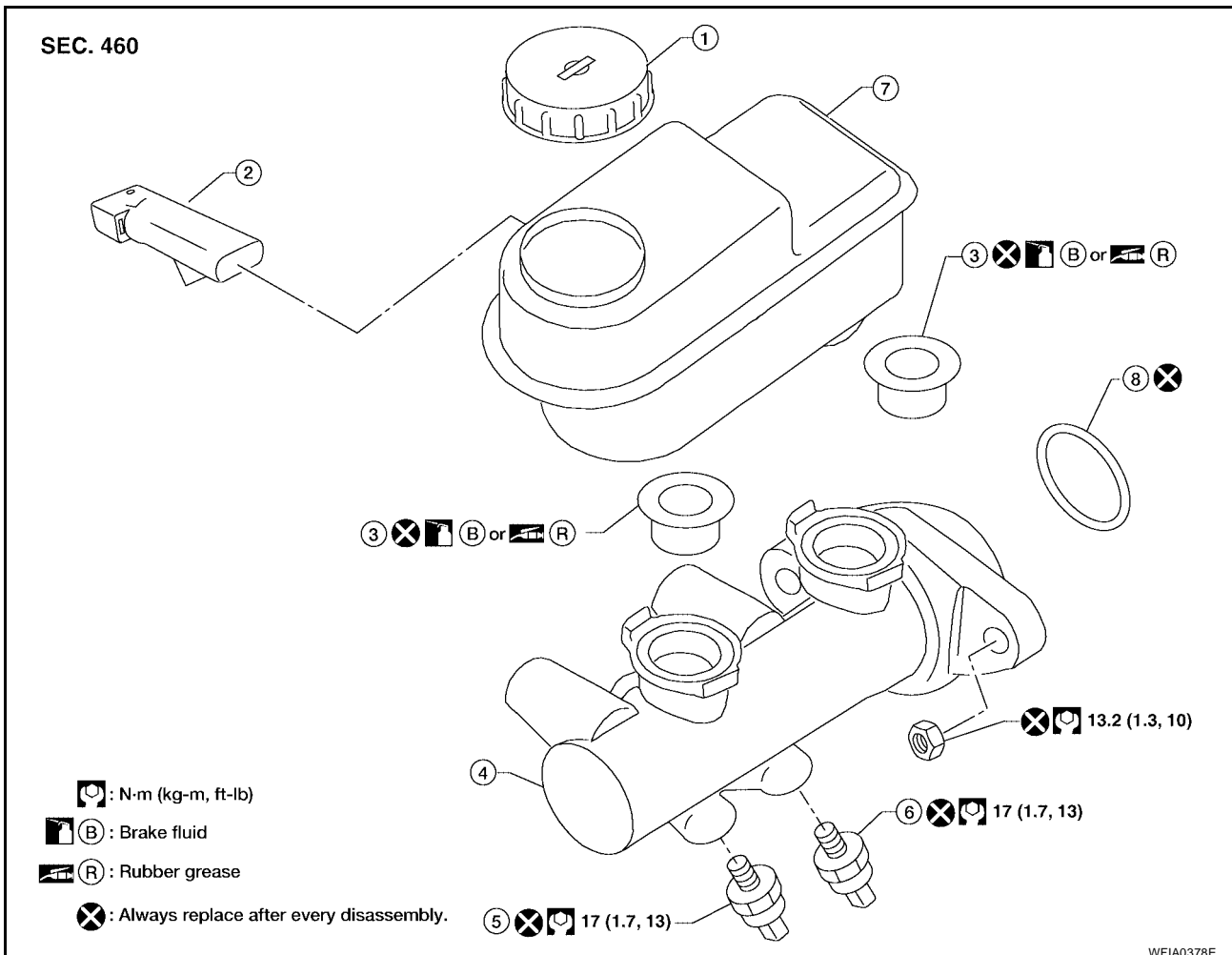

BRAKE MASTER CYLINDER

- | | | |
|---------------------------------|--------------------------|-------------------------|
| 1. Reservoir cap | 2. Fluid level sensor | 3. Grommet |
| 4. Master cylinder sub-assembly | 5. Front pressure sensor | 6. Rear pressure sensor |
| 7. Reservoir tank | 8. Seal | |

CAUTION:

Be careful not to splash brake fluid on painted areas; it may cause paint damage. If brake fluid is splashed on painted areas, wash it away with water immediately.

REMOVAL AND INSTALLATION

Removal

1. Drain brake fluid. Refer to [BR-10, "Drain and Refill"](#).
2. Disconnect harness connectors for fluid level sensor and pressure sensors.
3. Using a flare nut wrench, disconnect brake tube from master cylinder assembly.
4. Remove master cylinder assembly mounting nuts and master cylinder assembly.

Installation

Installation is in the reverse order of removal.

- Refill brake fluid and bleed air. Refer to [BR-11, "Bleeding Brake System"](#).

CAUTION:

- Refill with recommended brake fluid. Refer to [MA-11, "RECOMMENDED FLUIDS AND LUBRICANTS"](#).
- Do not reuse drained brake fluid.
- Adjust brake pedal. Refer to [BR-6, "ADJUSTMENT"](#).

DISASSEMBLY AND ASSEMBLY

Disassembly

CAUTION:

- Master cylinder cannot be disassembled.
 - Remove reservoir tank only when absolutely necessary.
1. Pull reservoir tank off master cylinder sub-assembly, then remove grommets from master cylinder sub-assembly body.
 2. Remove master cylinder pressure sensors.

Assembly

CAUTION:

- Never use mineral oil such as kerosene or gasoline during the cleaning and assembly process.
 - Do not drop parts. If a part is dropped, do not use it.
1. Apply brake fluid or rubber grease to new grommets, then insert into master cylinder sub-assembly. Refer to [MA-11, "RECOMMENDED FLUIDS AND LUBRICANTS"](#).

CAUTION:

- Do not reuse grommet.
2. Install reservoir tank onto master cylinder assembly.
 3. Install master cylinder pressure sensors.

BRAKE BOOSTER

BRAKE BOOSTER

PFP:47200

On-Vehicle Service OPERATING CHECK

EFS0030C

With engine stopped, change the vacuum to the atmospheric pressure by depressing brake pedal several times. Then with brake pedal fully depressed, start engine and when the vacuum pressure reaches the standard, make sure the clearance between brake pedal and floor panel decreases.

CAUTION:
Depressing pedal interval is approximately 5 seconds.

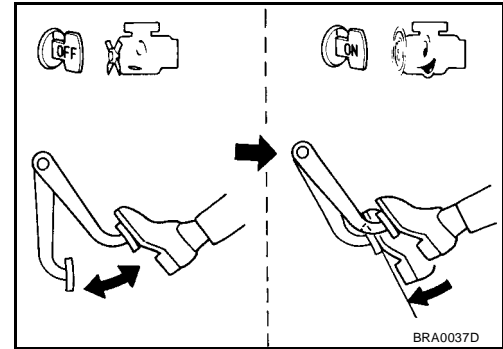

AIRTIGHT CHECK

- Run engine at idle for approximately 1 minute, and stop it after applying vacuum to booster. Depress brake pedal normally to change the vacuum to the atmospheric pressure. Make sure distance between brake pedal and floor panel gradually increases.
- Depress brake pedal while engine is running and stop engine with pedal depressed. The pedal stroke should not change after holding pedal down for 30 seconds.

CAUTION:
Depressing pedal interval is approximately 5 seconds.

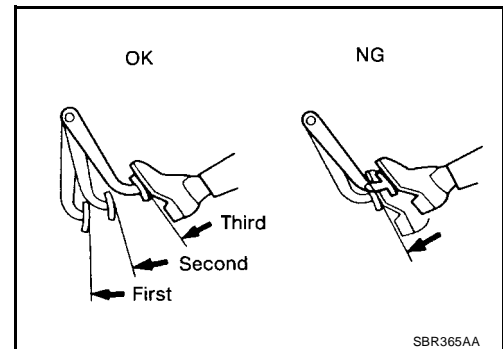

BRAKE BOOSTER

With ABS or BLSD

EFS0030D

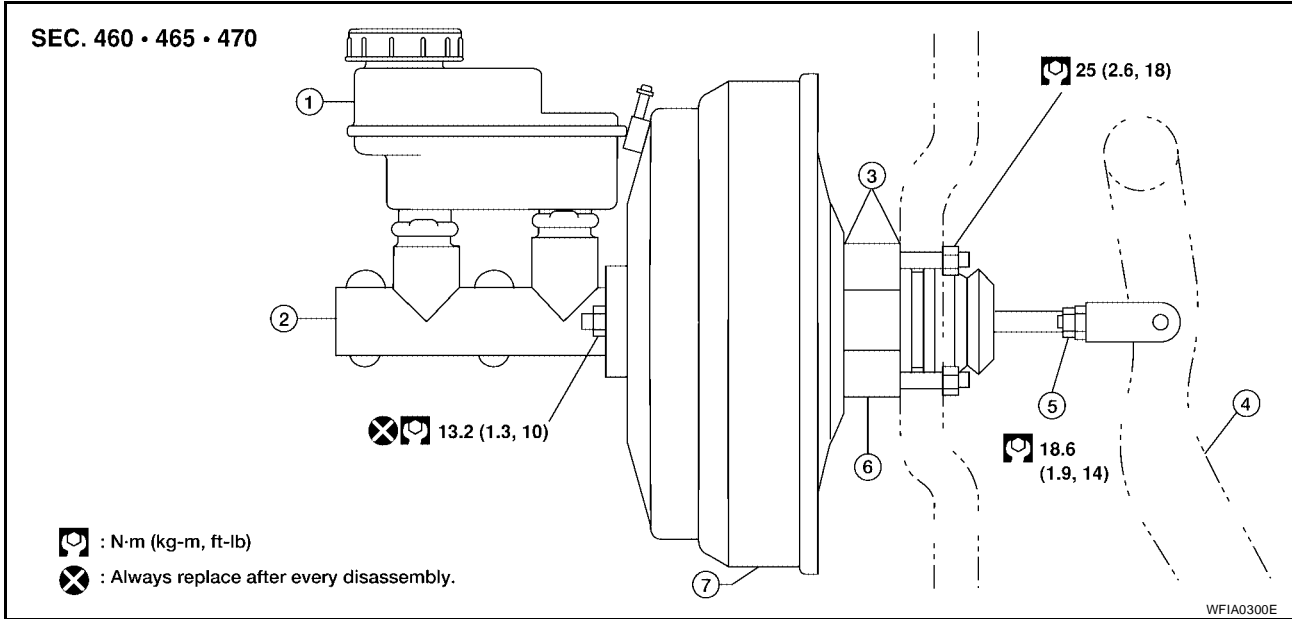

- | | | |
|-------------------|--------------------|-----------------|
| 1. Reservoir tank | 2. Master cylinder | 3. Gasket |
| 4. Brake pedal | 5. Lock nut | 6. Spacer block |
| 7. Brake booster | | |

REMOVAL

CAUTION:

- Be careful not to deform or bend brake piping while removing and installing brake booster.
- Replace clevis pin if it is damaged.
- Be careful not to damage brake booster stud bolt threads. If brake booster is tilted or inclined during installation, dash panel may damage the threads.
- Attach the check valve in the correct direction.

1. Remove engine room cover with power tool. Refer to [EM-11, "Removal and Installation"](#).
2. Remove engine air duct assembly. Refer to [EM-14, "Removal and Installation"](#).
3. Remove brake piping from brake master cylinder.
4. Remove brake master cylinder. Refer to [BR-15, "With ABS"](#).
5. Remove vacuum hose from brake booster. Refer to [BR-22, "VACUUM LINES"](#).
6. Remove brake pedal attachment snap pin and clevis pin from inside the vehicle.
7. Remove nuts on brake booster and brake pedal assembly.
8. Remove brake booster assembly from dash panel.

INSPECTION AFTER REMOVAL

Output Rod Length Inspection

1. Using a handy vacuum pump, apply a vacuum of -66.7 kPa (-500 mmHg , -19.69 inHg) to brake booster.
2. Check output rod length.

Standard dimension when vacuum -66.7 kPa (-500 mmHg , -19.69 inHg) : $15.6 - 15.9 \text{ mm}$ ($0.614 - 0.626 \text{ in}$)

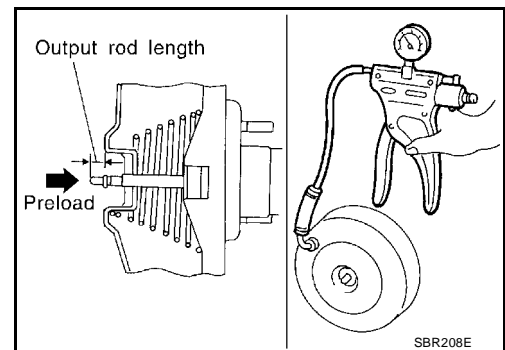

BRAKE BOOSTER

INSTALLATION

- Loosen lock nut to adjust input rod length so that the length B (in the figure) satisfies the specified value.

Length "B" : 148.5 mm (5.85 in)

- After adjusting "B", temporarily tighten lock nut and install booster assembly to the vehicle.
 - Install a gaskets and spacer block between booster assembly and the dash panel.
- Connect brake pedal with clevis of input rod.
- Install pedal bracket mounting nuts and tighten them to the specified torque.
- Install brake piping from brake master cylinder to ABS actuator. Refer to [BR-12, "Hydraulic Circuit"](#).
- Connect vacuum hose to brake booster.
- Install master cylinder to booster assembly. Refer to [BR-19, "With ABS or BLS"](#).
- Adjust the height and play of brake pedal. Refer to [BR-6, "ADJUSTMENT"](#).
- Tighten lock nut of input rod to the specified torque.
- Install engine air duct assembly. Refer to [EM-14, "Removal and Installation"](#).
- Install engine room cover. Refer to [EM-11, "Removal and Installation"](#).
- Refill brake fluid and bleed air. Refer to [BR-11, "Bleeding Brake System"](#).

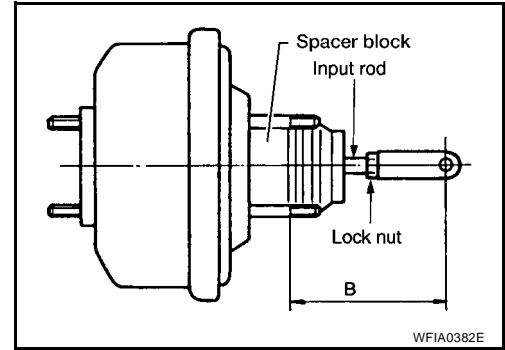

CAUTION:

- Refill with new brake fluid. Refer to [MA-11, "RECOMMENDED FLUIDS AND LUBRICANTS"](#).
- Do not reuse drained brake fluid.

With VDC

EFS004BB

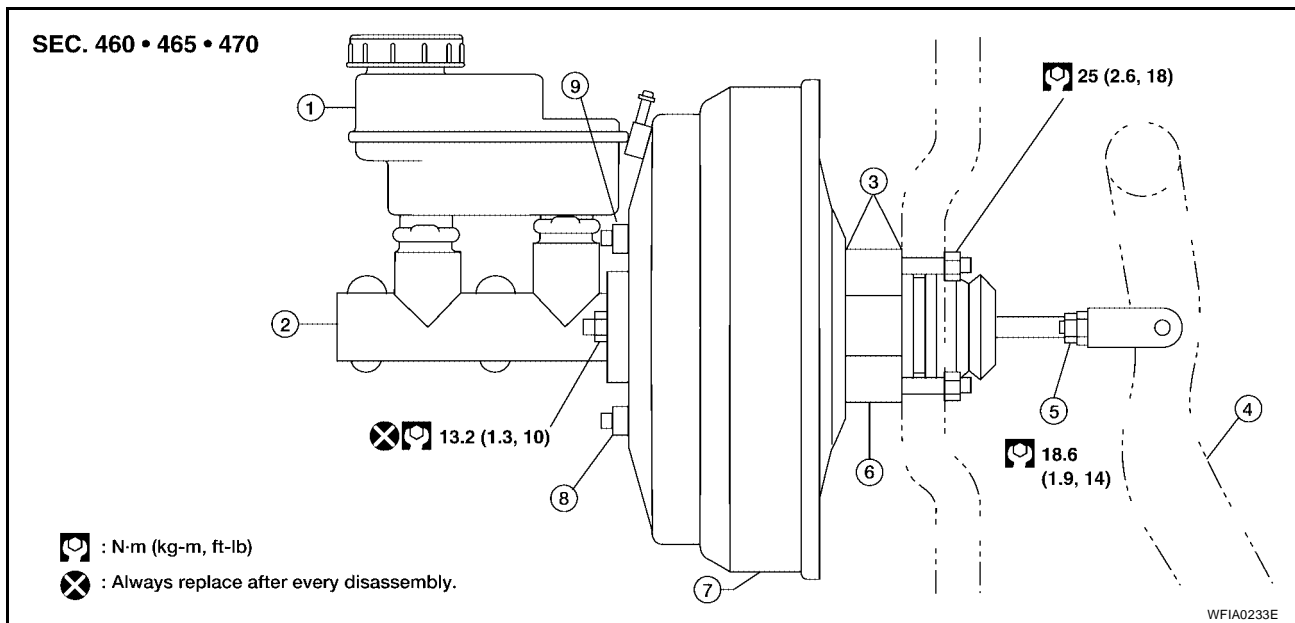

- | | | |
|-------------------|--------------------|------------------------|
| 1. Reservoir tank | 2. Master cylinder | 3. Gasket |
| 4. Brake pedal | 5. Lock nut | 6. Spacer block |
| 7. Brake booster | 8. Active booster | 9. Delta stroke sensor |

REMOVAL

CAUTION:

- Be careful not to deform or bend brake piping while removing and installing brake booster.
- Replace clevis pin if it is damaged.
- Be careful not to damage brake booster stud bolt threads. If brake booster is tilted or inclined during installation, dash panel may damage the threads.
- Attach the check valve in the correct direction.

BRAKE BOOSTER

1. Remove engine room cover with power tool. Refer to [EM-11, "Removal and Installation"](#).
2. Remove engine air duct assembly. Refer to [EM-14, "Removal and Installation"](#).
3. Remove brake piping from brake master cylinder.
4. Remove brake master cylinder. Refer to [BR-15, "With ABS"](#).
5. Remove vacuum hose from brake booster. Refer to [BR-22, "VACUUM LINES"](#).
6. Disconnect active boost and delta stroke sensor harness connectors from brake booster assembly.
7. Remove brake pedal attachment snap pin and clevis pin from inside the vehicle.
8. Remove nuts on brake booster and brake pedal assembly.
9. Remove brake booster assembly from dash panel.

INSPECTION AFTER REMOVAL

Output Rod Length Inspection

1. Using a handy vacuum pump, apply a vacuum of -66.7 kPa (-500 mmHg , -19.69 inHg) to brake booster.
2. Check output rod length.

Standard dimension when vacuum -66.7 kPa (-500 mmHg , -19.69 inHg) : $15.6 - 15.9 \text{ mm}$ ($0.614 - 0.626 \text{ in}$)

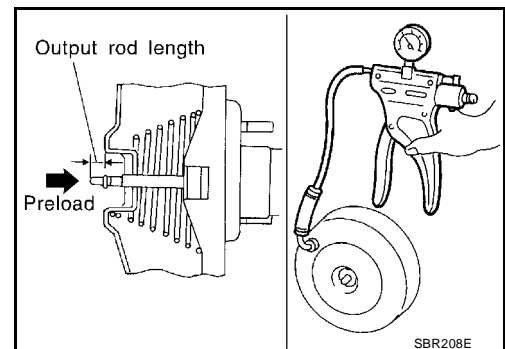

INSTALLATION

1. Loosen lock nut to adjust input rod length so that the length B (in the figure) satisfies the specified value.

Length "B" : 148.5 mm (5.85 in)

2. After adjusting "B", temporarily tighten lock nut and install booster assembly to the vehicle.
 - Install a gaskets and spacer block between booster assembly and the dash panel.
3. Connect brake pedal with clevis of input rod.
4. Install pedal bracket mounting nuts and tighten them to the specified torque.

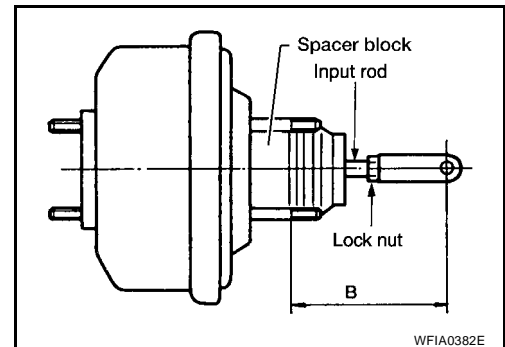

5. Install brake piping from brake master cylinder to ABS actuator. Refer to [BR-12, "Hydraulic Circuit"](#).
6. Connect active boost and delta stroke sensor harness connectors to brake booster assembly.
7. Connect vacuum hose to brake booster.
8. Install master cylinder to booster assembly. Refer to [BR-20, "With VDC"](#).
9. Adjust the height and play of brake pedal. Refer to [BR-6, "ADJUSTMENT"](#).
10. Tighten lock nut of input rod to the specified torque.
11. Install engine air duct assembly. Refer to [EM-14, "Removal and Installation"](#).
12. Install engine room cover. Refer to [EM-11, "Removal and Installation"](#).
13. Refill brake fluid and bleed air. Refer to [BR-11, "Bleeding Brake System"](#).

CAUTION:

- Refill with new brake fluid. Refer to [MA-11, "RECOMMENDED FLUIDS AND LUBRICANTS"](#).
- Do not reuse drained brake fluid.

VACUUM LINES

PFP:41920

VACUUM LINES

Removal and Installation

EFS0030E

SEC. 470

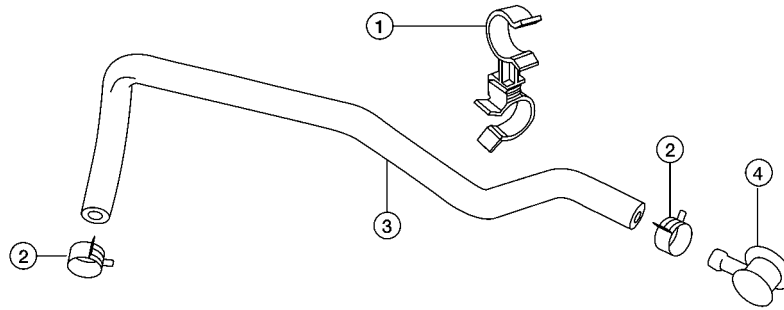

LFIA0216E

1. Hose clip
2. Clamp
3. Vacuum hose
4. Check valve

1. Disconnect vacuum hose from hose clip.
2. Release clamps and disconnect vacuum hose.
3. Remove check valve from brake booster.
4. Installation is in the reverse order of removal.

CAUTION:

- Insert vacuum hose for at least 24 mm (0.94 in).
- Do not use lubricating oil during assembly.

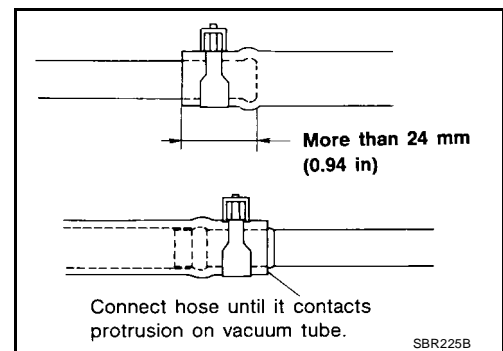

Inspection

VISUAL INSPECTION

Check for improper assembly, damage and deterioration.

CHECK VALVE INSPECTION

Airtightness Inspection

Use a suitable vacuum pump to check. Connect to brake booster side of check valve.

Check valve specification : Vacuum decrease should be within 1.3 kPa (10 mmHg, 0.39 inHg) for 15 seconds under a vacuum of - 66.7 kPa (- 500 mmHg, - 19.69 inHg)

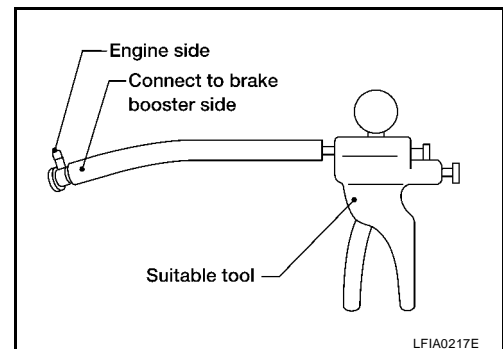

FRONT DISC BRAKE

PFP:41000

EFS0030G

FRONT DISC BRAKE

On-vehicle Inspection PAD WEAR INSPECTION

- Inspect the thickness of pad through cylinder body inspection hole. Use a scale for inspection if necessary.

Standard thickness : 11.88 mm (0.468 in)
Repair limit thickness : 1.0 mm (0.039 in)

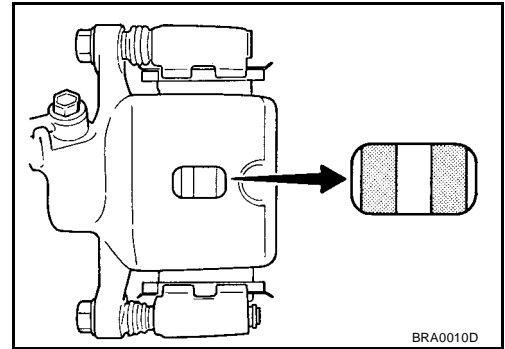

BRA0010D

Components

EFS0030H

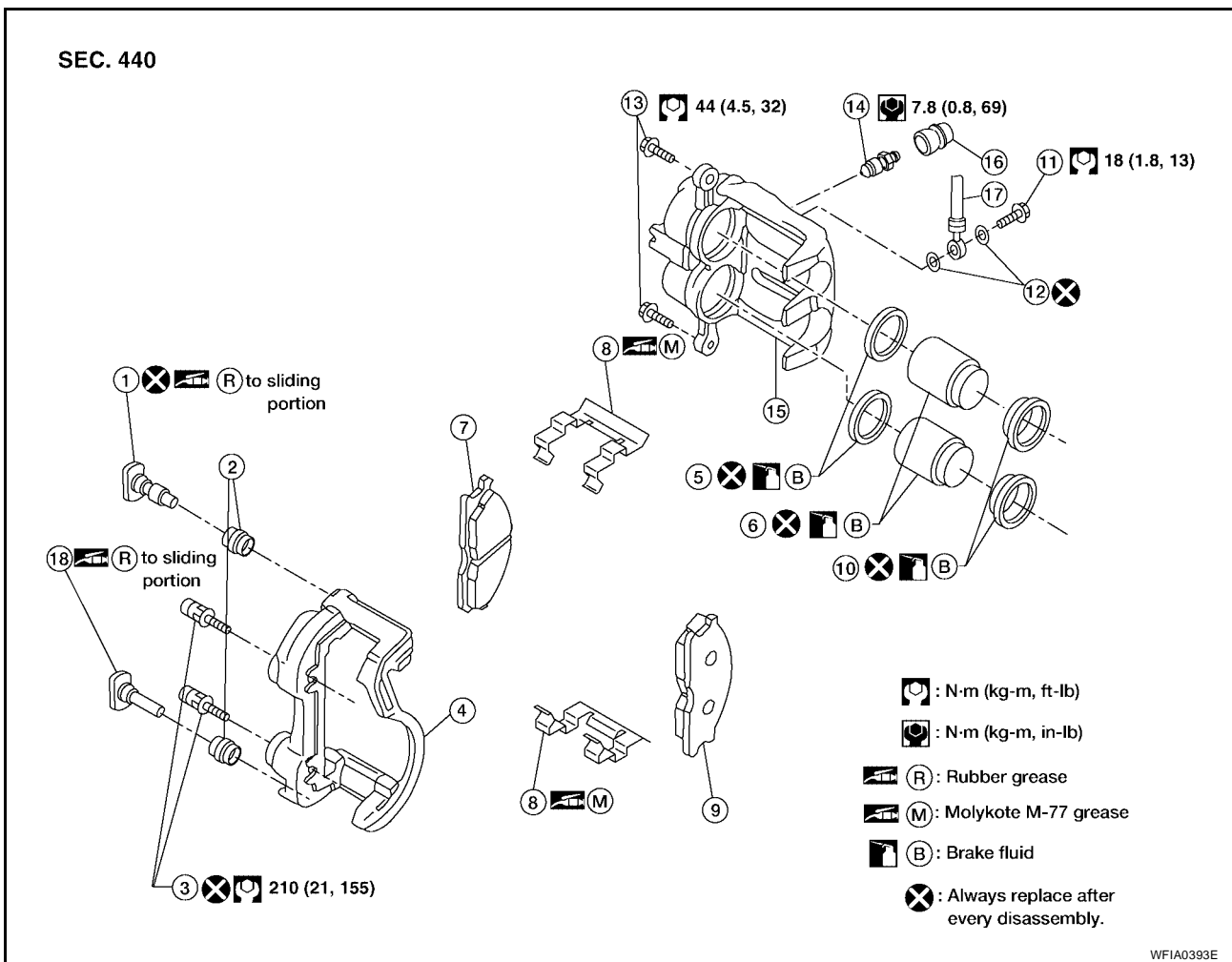

WFIA0393E

- | | | |
|----------------------|---------------------|-----------------------|
| 1. Upper sliding pin | 2. Sliding pin boot | 3. Torque member bolt |
| 4. Torque member | 5. Piston seal | 6. Piston |
| 7. Inner pad | 8. Pad retainer | 9. Outer pad |
| 10. Piston boot | 11. Union bolt | 12. Copper washer |
| 13. Sliding pin bolt | 14. Bleed valve | 15. Cylinder body |
| 16. Cap | 17. Brake hose | 18. Lower sliding pin |

WARNING:

Clean dust on caliper and brake pad with a vacuum dust collector to minimize the hazard of airborne particles or other materials.

FRONT DISC BRAKE

CAUTION:

- While removing cylinder body never depress brake pedal because piston will pop out.
- It is not necessary to remove bolts on torque member and brake hose except for disassembly or replacement of caliper assembly. In this case, hang cylinder body with a wire so as not to stretch brake hose.
- Do not damage piston boot.
- Burnish brake contact surface after refinishing or replacing rotors, after replacing pads, or if a soft pedal occurs at very low mileage. Refer to [BR-27, "BRAKE BURNISHING PROCEDURE"](#) .

Removal and Installation of Brake Pad

EFS0030I

REMOVAL

1. Remove tires from vehicle using power tool.
2. Remove lower sliding pin bolt.
3. Suspend cylinder body with a wire and remove pad and shim from torque member.

INSTALLATION

1. Push pistons in so that pad is firmly installed and mount cylinder body to torque member.

NOTE:

Using a disc brake piston tool (commercial service tool), etc., makes it easier to push in piston.

CAUTION:

By pushing in piston, brake fluid returns to master cylinder reservoir tank. Watch the level of the surface of reservoir tank.

2. Attach pad retainer to torque member.

CAUTION:

When attaching pad retainer, attach it firmly so that it does not float up higher than torque member, as shown in the figure.

3. Install lower sliding pin bolt and tighten it to the specified torque. Refer to [BR-23, "Components"](#) .
4. Check brake for drag.
5. Install tires to the vehicle. Refer to [WT-6, "Rotation"](#) .

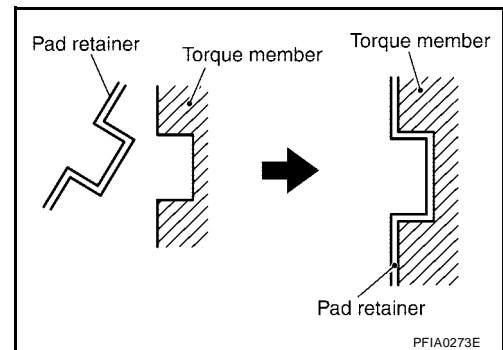

Removal and Installation of Brake Caliper Assembly and Disc Rotor

EFS0030J

REMOVAL

1. Remove tires from vehicle using power tool.
2. Drain brake fluid as necessary. Refer to [BR-10, "Drain and Refill"](#) .

NOTE:

Do not remove union bolt unless removing brake caliper assembly from vehicle.

3. Remove union bolt as necessary and torque member bolts, then remove brake caliper assembly from the vehicle.

NOTE:

Position brake caliper assembly aside using suitable wire, as necessary.

NOTE:

When servicing brake caliper, remove sliding pin bolts and caliper from torque member.

4. Remove disc rotor.

INSTALLATION

CAUTION:

- Refill with new brake fluid. Refer to [MA-11, "RECOMMENDED FLUIDS AND LUBRICANTS"](#) .
 - Do not reuse drained brake fluid.
1. Install disc rotor.
 2. Install sliding pin bolts if removed and tighten to specified torque. Refer to [BR-23, "Components"](#) .

FRONT DISC BRAKE

3. Install caliper assembly to the vehicle, then tighten torque member bolts to the specified torque. Refer to [BR-23, "Components"](#).

CAUTION:

- When attaching caliper assembly to the vehicle, wipe any oil off knuckle spindle, washers and caliper assembly attachment surfaces.
- Do not reuse caliper torque member bolts.

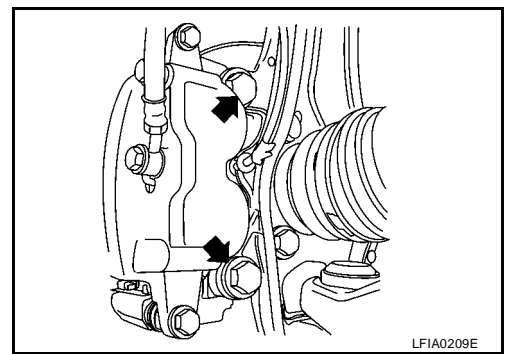

4. Install brake hose to brake caliper assembly, then tighten union bolt to the specified torque. Refer to [BR-23, "Components"](#).

CAUTION:

- Do not reuse copper washers for union bolt.
- Attach brake hose to caliper assembly together with union bolt and washers.

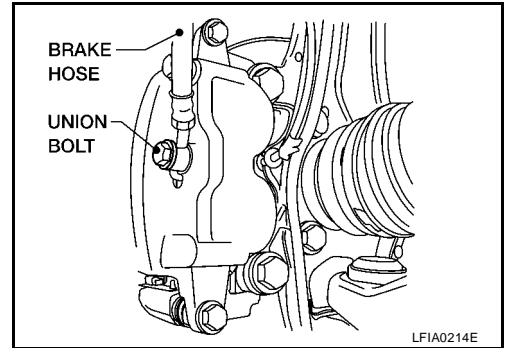

5. Refill new brake fluid and bleed air. Refer to [BR-11, "Bleeding Brake System"](#).
6. Attach tires to the vehicle. Refer to [WT-6, "Rotation"](#).

Disassembly and Assembly of Brake Caliper Assembly

EF50030K

- ### DISASSEMBLY
1. Remove sliding pin bolt, and then remove the pad, shim, shim cover, and pad retainer from the torque member.
 2. Remove sliding pins and sliding pin boots from torque member.
 3. Place a wooden block as shown, and blow air from union bolt mounting hole to remove pistons and piston boots.

CAUTION:

Do not get your fingers caught in piston.

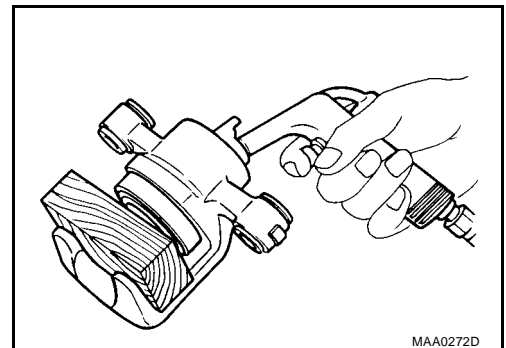

4. Using a flat-bladed screwdriver, remove piston seal from cylinder body.

CAUTION:

Be careful not to damage cylinder inner wall.

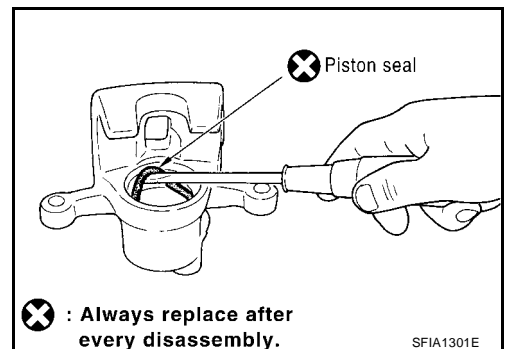

FRONT DISC BRAKE

CALIPER INSPECTION

Cylinder Body

CAUTION:

- Use new brake fluid for cleaning. Do not use mineral oils such as gasoline or kerosene.
- Check inside surface of cylinder for score, rust, wear, damage or foreign materials. If any of the above conditions are observed, replace cylinder body.
- Minor damage from rust or foreign materials may be eliminated by polishing surface with a fine emery paper. Replace cylinder body if necessary.

Torque Member

Check for wear, cracks, and damage. If damage or deformation is present, replace the affected part.

Piston

Check piston for score, rust, wear, damage or presence of foreign materials. Replace if any of the above conditions are observed.

CAUTION:

Piston sliding surface is plated, do not polish with emery paper even if rust or foreign materials are stuck to sliding surface.

Sliding Pins, and Sliding Pin Boots

Check sliding pin and sliding pin boot for wear, damage, and cracks. If damage or deformation is present, replace the affected part.

CAUTION:

Trailing/upper sliding pin must be replaced at each service.

ASSEMBLY

CAUTION:

Do not use NISSAN Rubber Grease (KRE00 00010, KRE00 00010 01) when assembling.

1. Apply clean brake fluid to new piston seal and insert seal in to groove on cylinder body. Refer to [MA-11, "RECOMMENDED FLUIDS AND LUBRICANTS"](#).

CAUTION:

Do not reuse piston seal.

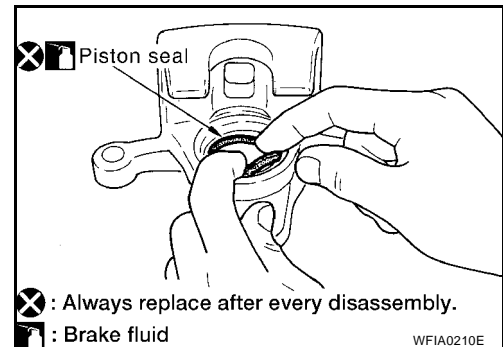

2. Apply clean brake fluid to piston and piston boot, then install piston boot in to piston groove.

CAUTION:

Do not reuse piston boot.

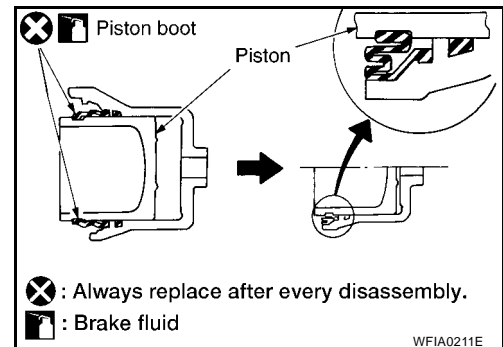

3. Insert into cylinder body by hand and insert piston boot piston-side lip into piston groove.

CAUTION:

Press piston evenly and vary the pressing point to prevent cylinder inner wall from being rubbed.

4. Install sliding pins and sliding pin boots to torque member.

CAUTION:

Trailing/upper sliding pin must be replaced at each service.

FRONT DISC BRAKE

5. Install cylinder body. Tighten sliding pin bolt to the specified torque. Refer to [BR-23, "Components"](#).

DISC ROTOR INSPECTION

Visual Inspection

Check surface of disc rotor for uneven wear, cracks, and serious damage. If any of them is detected, replace applicable part.

Runout Inspection

1. Using wheel nuts, install disc rotor to wheel hub at 2 or more positions.
2. Inspect runout using a dial gauge. (Measured at 10 mm (0.39 in) inside the disc edge.)

Runout limit (on vehicle) : 0.04 mm (0.0016 in)

NOTE:

Make sure that wheel bearing axial end play is within the specifications before measuring runout. Refer to [FAX-5, "WHEEL BEARING INSPECTION"](#).

3. If runout is outside the limit, find the minimum runout point by shifting mounting positions of disc rotor and wheel hub by one hole.
4. If runout still out of specification, turn rotor with on-car brake lathe.

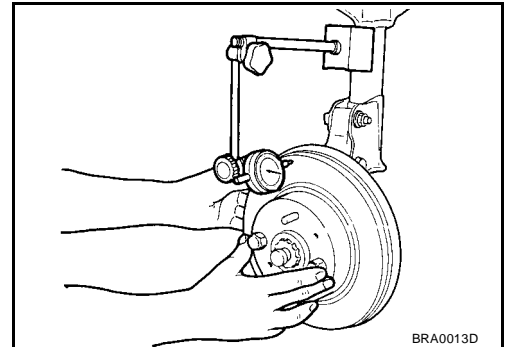

Thickness Inspection

Using a micrometer, check thickness of disc rotor. If thickness is either at or below the wear limit, or exceeds maximum uneven wear, replace disc rotor.

Standard thickness : 26.0 mm (1.024 in)

Repair limit thickness : 24.5 mm (0.965 in)

**Maximum uneven wear : 0.015 mm (0.0006 in)
(Measured at 8 positions)**

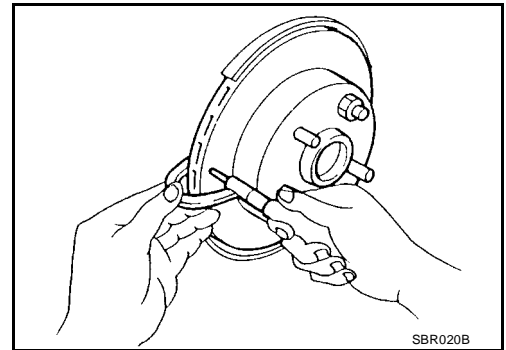

BRAKE BURNISHING PROCEDURE

Burnish brake contact surface according to the following procedure after refinishing or replacing rotors, after replacing pads, or if a soft pedal occurs at very low mileage.

CAUTION:

Only perform this procedure under safe road and traffic conditions. Use extreme caution.

1. Drive the vehicle on a straight smooth road at 50 km/h (31 MPH).
2. Use medium brake pedal/foot effort to bring the vehicle to a complete stop from 50 km/h (31 MPH). Adjust brake pedal/foot pressure such that vehicle stopping time equals 3 to 5 seconds.
3. To cool brake system, drive the vehicle at 50 km/h (31 MPH) for 1 minute without stopping.
4. Repeat steps 1 to 3, 10 times or more to complete the burnishing procedure.

REAR DISC BRAKE

REAR DISC BRAKE

PFP:44000

On-vehicle Inspection PAD WEAR INSPECTION

EFS0030L

- Inspect the thickness of pad through cylinder body inspection hole. Use a scale for inspection if necessary.

Standard thickness : 12.13 mm (0.478 in)

Repair limit thickness : 1.0 mm (0.039 in)

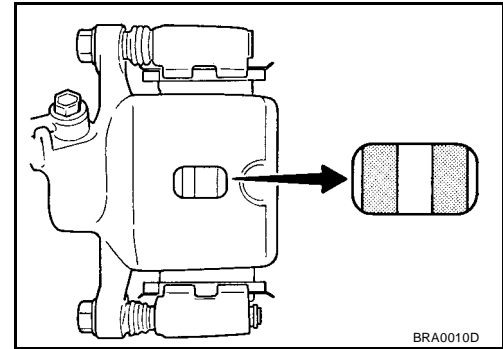

BRA0010D

Components

EFS0030M

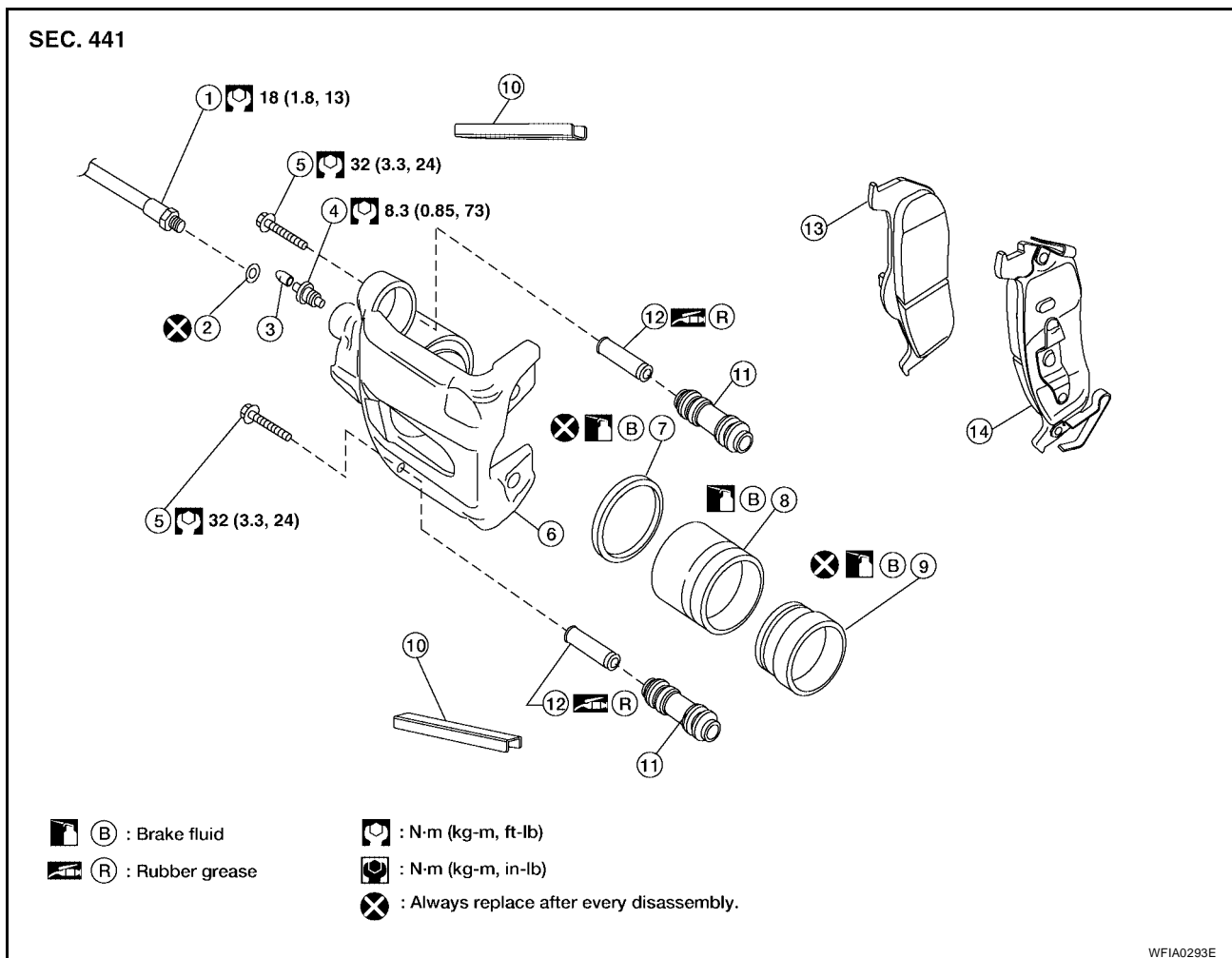

WFIA0293E

- | | | |
|-------------------|-------------------------|--------------------|
| 1. Brake hose | 2. Copper washer | 3. Cap |
| 4. Bleed valve | 5. Mounting bolt | 6. Cylinder body |
| 7. Piston seal | 8. Piston | 9. Piston boot |
| 10. Knuckle slide | 11. Sliding sleeve boot | 12. Sliding sleeve |
| 13. Inner pad | 14. Outer pad | |

WARNING:

Clean dust on caliper and brake pad with a vacuum dust collector to minimize the hazard of airborne particles or other materials.

REAR DISC BRAKE

CAUTION:

- While removing cylinder body, never depress brake pedal because piston will pop out.
- It is not necessary to remove the torque member and disconnect the brake hose except for disassembly or replacement of caliper assembly. When replacing brake pads, hang cylinder body with a wire so as not to stretch brake hose.
- Do not damage piston boot.
- Burnish brake contact surface after refinishing or replacing rotors, after replacing pads, or if a soft pedal occurs at very low mileage. Refer to [BR-33, "BRAKE BURNISHING PROCEDURE"](#).

Removal and Installation of Brake Pad

EFS0030N

REMOVAL

1. Remove tires from vehicle with power tool.
2. Remove mounting bolt from the top mount.
3. Swing cylinder body open, and remove pads.

INSTALLATION

1. Push piston in so that pad is firmly attached and mount cylinder body to torque member.

NOTE:

Using a disc brake piston tool (commercial service tool), makes it easier to push in the piston.

CAUTION:

By pushing in piston, brake fluid returns to master cylinder reservoir tank. Watch the level of the surface of reservoir tank.

2. Install pads to cylinder body.
3. Install top mounting bolt and tighten to specification.
4. Check brake for drag.
5. Install tires to the vehicle.

Removal and Installation of Brake Caliper Assembly and Disc Rotor

EFS0030O

REMOVAL

1. Remove tires from vehicle with power tool.
2. Drain brake fluid. Refer to [BR-10, "Drain and Refill"](#).
3. Remove brake hose and mounting bolts, and remove brake caliper assembly.
4. Remove disc rotor.

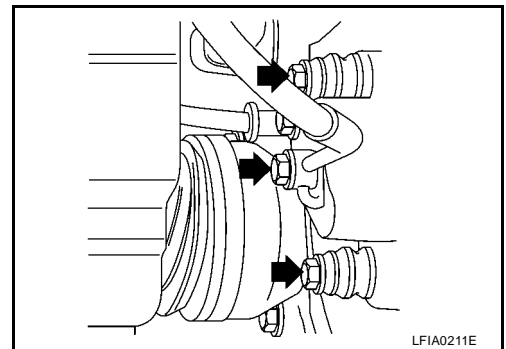

LFIA0211E

INSTALLATION

CAUTION:

- Refill with new brake fluid. Refer to [MA-11, "RECOMMENDED FLUIDS AND LUBRICANTS"](#).

- Do not reuse drained brake fluid.

1. Install disc rotor.
2. Install caliper assembly to the vehicle, and tighten mounting bolts to specification. Refer to [BR-28, "Components"](#).

CAUTION:

Before installing caliper assembly to the vehicle, wipe off mounting surface of caliper assembly.

3. Install brake hose to caliper assembly and tighten to specification. Refer to [BR-28, "Components"](#).

CAUTION:

- Do not reuse copper washer.
- Securely attach brake hose to protrusion on caliper assembly.

REAR DISC BRAKE

4. Refill new brake fluid and bleed air. Refer to [BR-11, "Bleeding Brake System"](#) .
5. Install tires to the vehicle.

REAR DISC BRAKE

EFS0030P

Disassembly and Assembly of Brake Caliper Assembly

DISASSEMBLY

1. Remove pads from cylinder body.
2. Remove sliding sleeve and boot from cylinder body.
3. Place a wooden block as shown, and blow air from union bolt mounting hole to remove piston and piston boot.

CAUTION:

Do not get your fingers caught in piston.

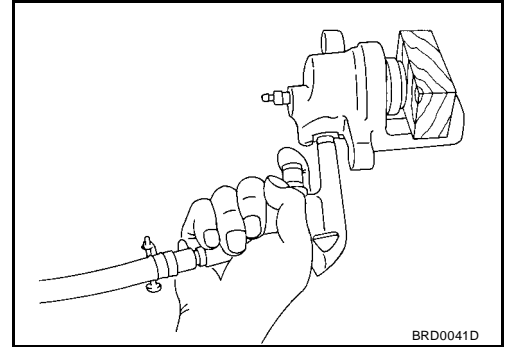

4. Using a flat-bladed screwdriver, remove piston seal from cylinder body.

CAUTION:

Be careful not to damage cylinder inner wall.

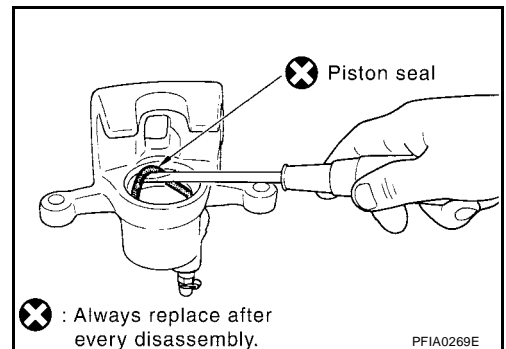

CALIPER INSPECTION

Cylinder Body

CAUTION:

- Use new brake fluid to clean. Do not use mineral oils such as gasoline or kerosene.
- Check inside surface of cylinder for score, rust wear, damage or foreign materials. If any of the above conditions are observed, replace cylinder body.
- Minor damage from rust or foreign materials may be eliminated by polishing surface with a fine emery paper. Replace cylinder body if necessary.

Torque Member

Check for wear, cracks, and damage. If damage or deformation is present, replace the affected part.

Piston

CAUTION:

- Piston sliding surface is plated, do not polish with emery paper even if rust or foreign materials are stuck to sliding surface.
- Check piston for score, rust, wear, damage or presence of foreign materials. Replace if any of the above conditions are observed.

Sliding Pin Bolts and Sliding Pin Boots

Make sure there is no wear, damage, or cracks in sliding sleeve and sliding sleeve boots, and if there are, replace them.

ASSEMBLY

CAUTION:

Do not use NISSAN Rubber Grease (KRE00 00010, KRE00 00010 01) when assembling.

A
B
C
D
E
BR
G
H
I
J
K
L
M

REAR DISC BRAKE

1. Apply clean brake fluid to new piston seal and insert into groove on cylinder body. Refer to [MA-11, "RECOMMENDED FLUIDS AND LUBRICANTS"](#).

CAUTION:

Do not reuse piston seal.

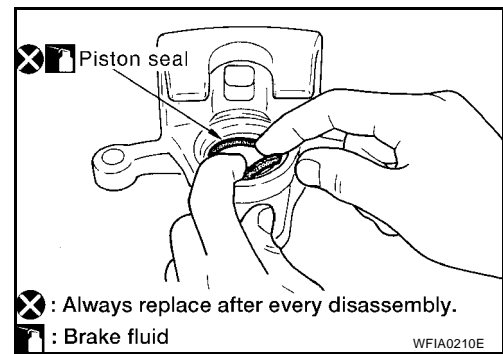

2. Apply brake fluid to piston and to piston boot, then install piston boot in to piston groove.

CAUTION:

Do not reuse piston boot.

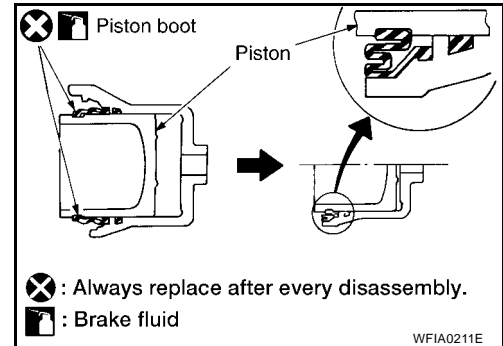

3. Insert piston into cylinder body by hand and insert piston boot piston-side lip into piston groove.

CAUTION:

Press piston evenly and vary the pressing point to prevent cylinder inner wall from being rubbed.

4. Install sliding boots and sleeves to cylinder body.

DISC ROTOR INSPECTION

Visual Inspection

Check surface of disc rotor for uneven wear, cracks, and serious damage. If any non-standard condition is detected, replace applicable part.

Runout Inspection

1. Using wheel nuts, install disc rotor to wheel hub at 2 or more positions.
2. Inspect runout using a dial gauge. [Measured at 10 mm (0.39 in) inside disk edge.]

Runout limit (on vehicle) : 0.05 mm (0.0020 in)

NOTE:

Make sure that wheel bearing axial end play is within the specification before measuring runout. Refer to [RAX-12, "Axle Bearing"](#).

3. If runout is outside the limit, find the minimum runout point by shifting mounting positions of disc rotor and wheel hub by one hole.
4. If runout still out of specification, turn rotor with on-car brake lathe.

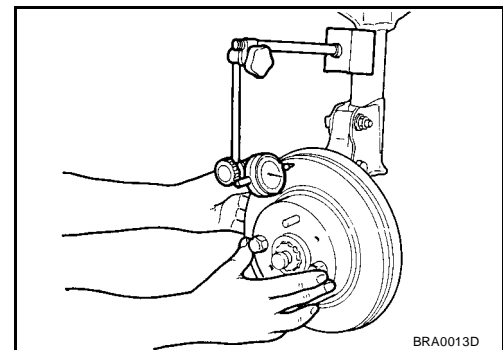

REAR DISC BRAKE

Thickness Inspection

Using a micrometer, check thickness of disc rotor. If thickness is either at or below the wear limit, or exceeds maximum uneven wear, replace disc rotor.

Standard thickness	: 14.0 mm (0.551 in)
Wear limit	: 12.0 mm (0.472 in)
Maximum uneven wear (measured at 8 positions)	: 0.015 mm (0.0006 in)

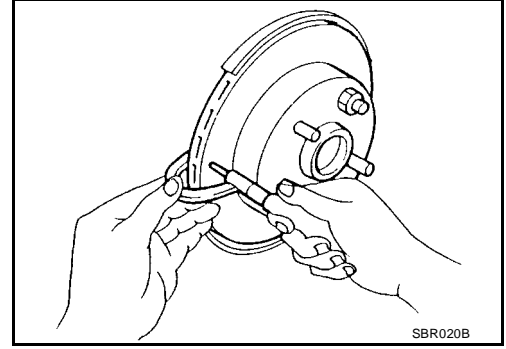

BRAKE BURNISHING PROCEDURE

Burnish brake contact surface according to the following procedure after refinishing or replacing rotors, after replacing pads, or if a soft pedal occurs at very low mileage.

CAUTION:

Only perform this procedure under safe road and traffic conditions. Use extreme caution.

1. Drive the vehicle on a straight smooth road at 50 km/h (31 MPH).
2. Use medium brake pedal/foot effort to bring the vehicle to a complete stop from 50 km/h (31 MPH). Adjust brake pedal/foot pressure such that vehicle stopping time equals 3 to 5 seconds.
3. To cool brake system, drive the vehicle at 50 km/h (31 MPH) for 1 minute without stopping.
4. Repeat steps 1 to 3, 10 times or more to complete the burnishing procedure.

A
B
C
D
E
BR
G
H
I
J
K
L
M

SERVICE DATA AND SPECIFICATIONS (SDS)

SERVICE DATA AND SPECIFICATIONS (SDS)

PF0:00030

General Specifications

EFS0030Q

Unit: mm (in)

Front brake	Brake model	CLZ31VC
	Rotor outer diameter × thickness	320 × 26 (12.60 × 1.02)
	Pad Length × width × thickness	111.0 × 73.5 × 9.5 (4.73 × 2.894 × 0.374)
	Cylinder bore diameter	51 (2.01)
Rear brake	Brake model	AD14VE
	Rotor outer diameter × thickness	320 × 14 (12.60 × 0.55)
	Pad Length × width × thickness	83.0 × 33.0 × 8.5 (3.268 × 1.299 × 0.335)
	Cylinder bore diameter	48 (1.89)
Control valve	Valve model	Electric brake force distribution
Brake booster	Booster model	C215T
	Diaphragm diameter	215 (8.46)
Recommended brake fluid		Refer to MA-11, "RECOMMENDED FLUIDS AND LUBRICANTS" .

Brake Pedal

EFS0030R

Brake pedal height (from dash panel top surface)	182.3 – 192.3 mm (7.18 – 7.57 in)
Depressed pedal height [under a force of 490 N (50 kg, 110 lb) with engine running]	More than 90.3 mm (3.55 in)
Clearance between stopper rubber and the threaded end of stop lamp switch	0.74 – 1.96 mm (0.029 – 0.077 in)
Pedal play	3 – 11 mm (0.12 – 0.43 in)

Brake Booster

EFS0030S

Input rod installation standard dimension	15.6 – 15.9 mm (0.614 – 0.626 in)
---	-----------------------------------

Check Valve

EFS0030T

Vacuum leakage [at vacuum of – 66.7 kPa(– 500 mmHg, – 19.69 inHg)]	Within 1.3 kPa (10 mmHg, 0.39 inHg) of vacuum for 15 seconds
---	--

Front Disc Brake

EFS0030U

Brake model		CLZ31VC
Brake pad	Standard thickness (new)	11.88 mm (0.468 in)
	Repair limit thickness	1.0 mm (0.039 in)
Disc rotor	Standard thickness (new)	26.0 mm (1.024 in)
	Repair limit thickness	24.5 mm (0.965 in)
	Maximum uneven wear (measured at 8 positions)	0.015mm (0.0006 in)
	Runout limit (with it attached to the vehicle)	0.04 mm (0.0016 in)

SERVICE DATA AND SPECIFICATIONS (SDS)

Rear Disc Brake

EFS0030V

Brake model		AD14VE
Brake pad	Standard thickness (new)	12.13 mm (0.478 in)
	Repair limit thickness	1.0 mm (0.039 in)
Disc rotor	Standard thickness (new)	14.0 mm (0.551 in)
	Repair limit thickness	12.0 mm (0.472 in)
	Maximum uneven wear (measured at 8 positions)	0.015 mm (0.0006 in)
	Runout limit (with it attached to the vehicle)	0.05 mm (0.0020 in)

A
B
C
D
E
G
H
I
J
K
L
M

BR

SERVICE DATA AND SPECIFICATIONS (SDS)
