

SECTION **LU**
ENGINE LUBRICATION SYSTEM

CONTENTS

PRECAUTIONS	2	OIL COOLER	10	
Precautions for Liquid Gasket	2	Removal and Installation	10	
REMOVAL OF LIQUID GASKET SEALING	2	REMOVAL	10	
LIQUID GASKET APPLICATION PROCEDURE.....	2	INSPECTION AFTER REMOVAL	10	
PREPARATION	3	INSTALLATION	11	
Special Service Tools	3	INSPECTION AFTER INSTALLATION	11	
Commercial Service Tool	4	OIL PUMP	12	
LUBRICATION SYSTEM	5	Removal and Installation	12	
Lubrication Circuit	5	REMOVAL	12	
System Drawing	6	INSTALLATION	12	
ENGINE OIL	7	INSPECTION AFTER INSTALLATION	13	
Inspection	7	Disassembly and Assembly	13	
OIL LEVEL	7	DISASSEMBLY	13	
OIL APPEARANCE	7	INSPECTION AFTER DISASSEMBLY	13	
OIL LEAKAGE	7	ASSEMBLY	14	
OIL PRESSURE CHECK	7	SERVICE DATA AND SPECIFICATIONS (SDS)	15	
Changing Engine Oil	8	Standard and Limit	15	
OIL FILTER	9	OIL PRESSURE	15	
Removal and Installation	9	OIL PUMP	15	
REMOVAL	9	REGULATOR VALVE	15	
INSTALLATION	9	ENGINE OIL CAPACITY	15	
INSPECTION AFTER INSTALLATION	9			

PRECAUTIONS

PFP:00001

EBS00J9N

PRECAUTIONS

Precautions for Liquid Gasket REMOVAL OF LIQUID GASKET SEALING

- After removing the bolts and nuts, separate the mating surface using Tool and remove the sealant.

Tool number : KV10111100 (J-37228)

CAUTION:

Be careful not to damage the mating surfaces.

- In areas where the cutter is difficult to use, use a plastic hammer to lightly tap the areas where the sealant is applied.

CAUTION:

If for some unavoidable reason a tool such as a flat-bladed screwdriver is used, be careful not to damage the mating surfaces.

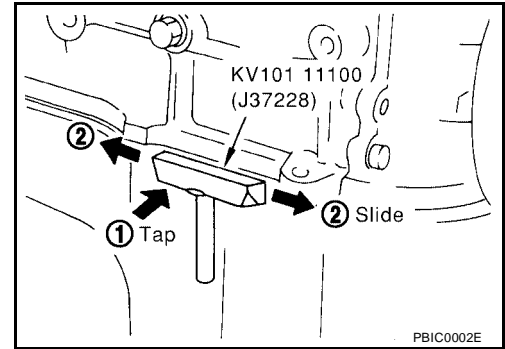

LIQUID GASKET APPLICATION PROCEDURE

- Remove the old sealant adhering to the mating surface. Using suitable tool.
 - Remove the sealant completely from the groove, bolts, and bolt holes.
- Thoroughly clean the mating surface removing any adhering moisture, grease and foreign material.
- Attach the sealant tube to the Tool.

Tool number : WS39930000 (-)

Use Genuine RTV Silicone Sealant or equivalent. Refer to [GI-45, "Recommended Chemical Products and Sealants"](#).

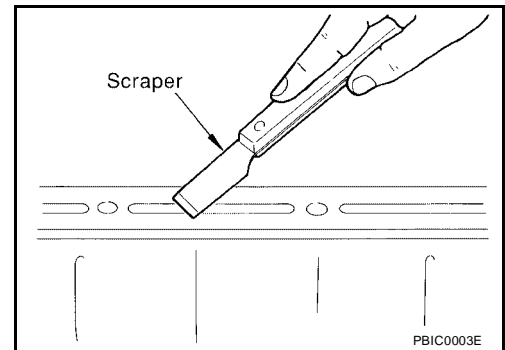

- Apply the sealant without breaks to the specified location with the specified dimensions.
 - If there is a groove for the sealant application, apply the sealant to the groove.

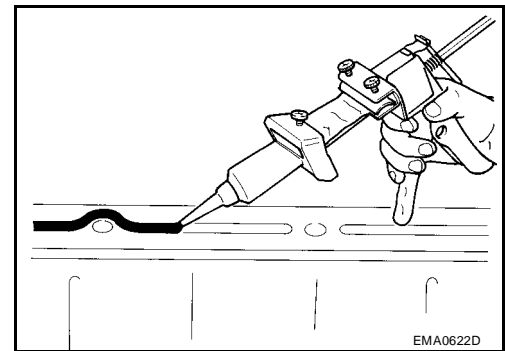

- As for the bolt holes, normally apply the sealant inside the holes. Occasionally, it should be applied outside the holes. Make sure to read the text of service manual.
- Within five minutes of sealant application, install the mating component.
- If the sealant protrudes, wipe it off immediately.
- Do not retighten after the installation.
- After 30 minutes or more have passed from the installation, fill the engine with the proper oil and coolant. Refer to [GI-45, "Recommended Chemical Products and Sealants"](#).

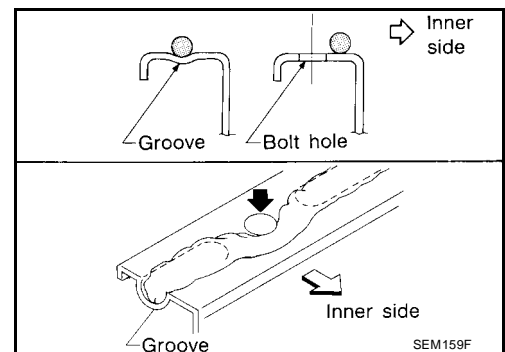

PREPARATION

PREPARATION

PFP:00002

Special Service Tools

EBS0011C

The actual shapes of Kent-Moore tools may differ from those of special service tools illustrated here.

Tool number (Kent-Moore No.) Tool name	Description
ST25051001 (J-25695-1) Oil pressure gauge	Measuring oil pressure Maximum measuring range: 2,452 kPa (25 kg/cm² , 356 psi)
ST25052000 (J-25695-2) Hose	Adapting oil pressure gauge to cylinder block
KV10111100 (J-37228) Seal cutter	Removing steel oil pan and rear timing chain case
KV10115801 (J-38956) Oil filter wrench	Removing and installing oil filter a: 64.3 mm (2.531 in)
WS39930000 (—) Tube presser	Pressing the tube of liquid gasket

A
 LU
 C
 D
 E
 F
 G
 H
 I
 J
 K
 L
 M

PREPARATION

Commercial Service Tool

EBS0011D

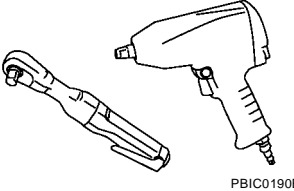
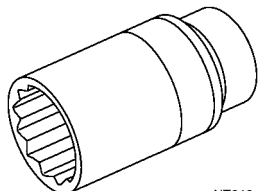
Tool name	Description
<p data-bbox="162 247 267 273">Power tool</p>  <p data-bbox="852 451 917 472">PBIC0190E</p>	<p data-bbox="1015 247 1266 273">Loosening bolts and nuts</p>
<p data-bbox="162 478 284 504">Deep socket</p>  <p data-bbox="852 703 901 724">NT818</p>	<p data-bbox="1015 478 1445 535">Removing and installing oil pressure switch Deep socket 26 mm (1.02 in)</p>

LUBRICATION SYSTEM

LUBRICATION SYSTEM

PFP:15010

Lubrication Circuit

EBS001E

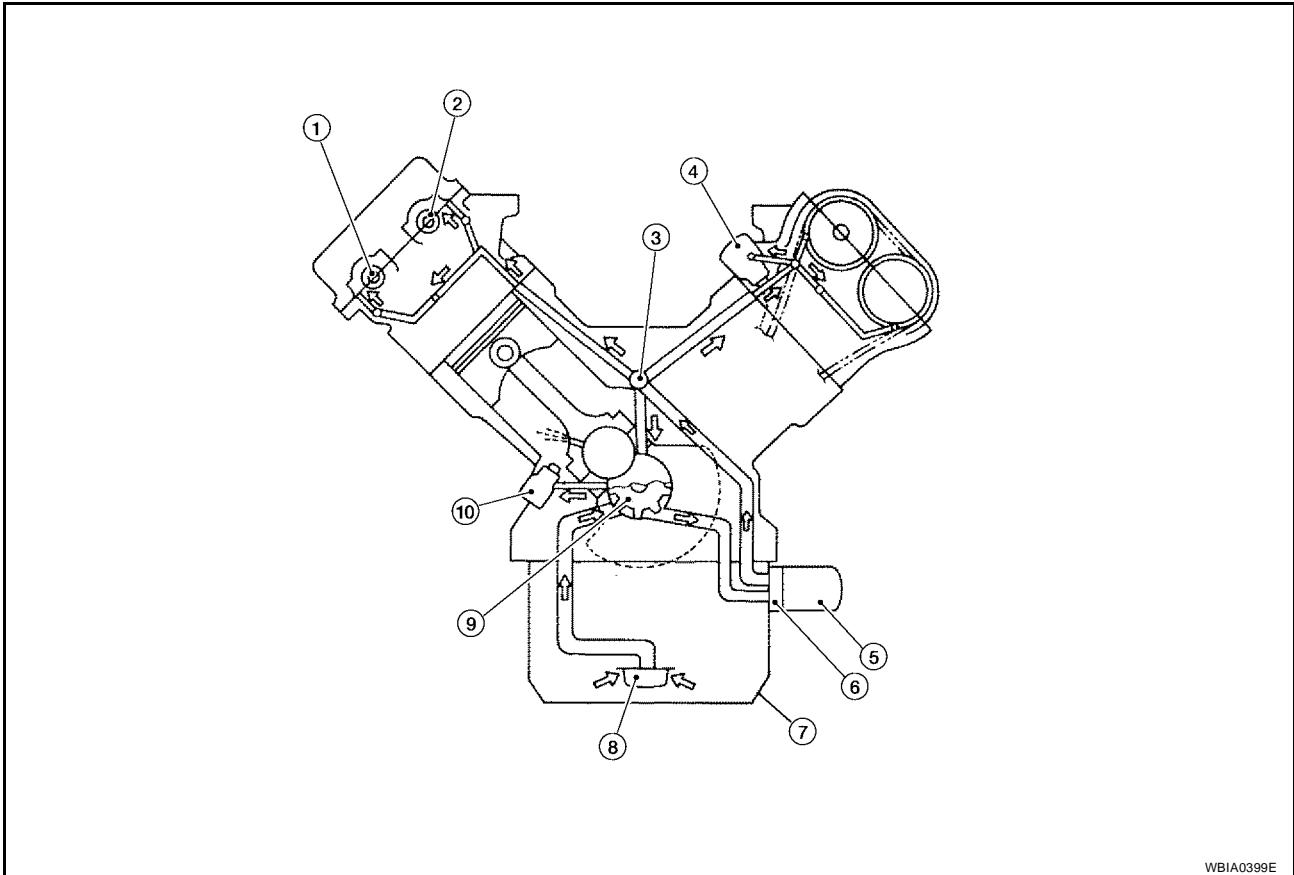

WBIA0399E

- | | | |
|----------------------------------|--------------------|--------------------|
| 1. Exhaust camshaft | 2. Intake camshaft | 3. Main oil galley |
| 4. Chain tensioner (Left bank) | 5. Oil filter | 6. Oil cooler |
| 7. Oil pan | 8. Oil strainer | 9. Oil pump |
| 10. Chain tensioner (Right bank) | | |

A

LU

C

D

E

F

G

H

I

J

K

L

M

LUBRICATION SYSTEM

System Drawing

EBS0011F

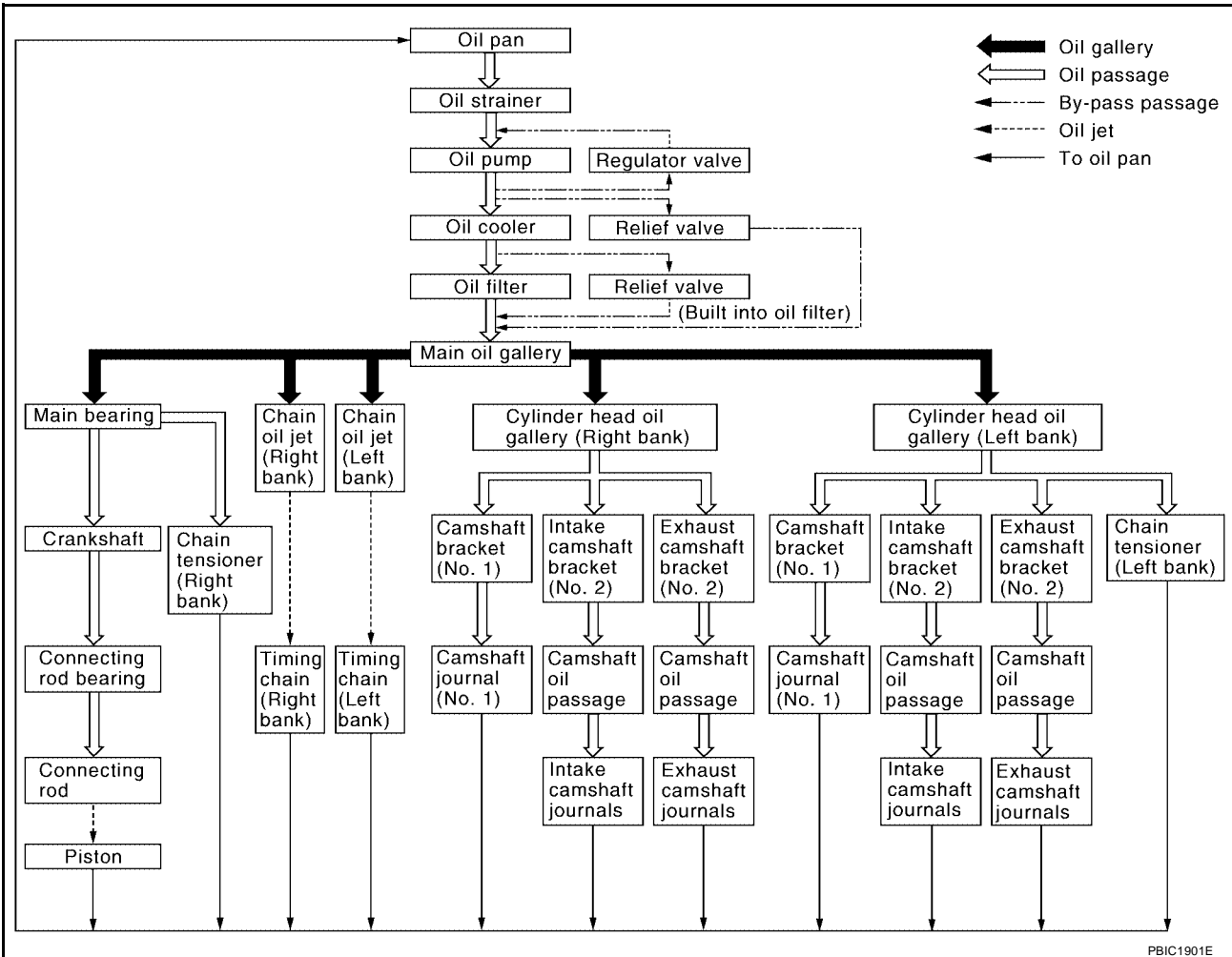

PBIC1901E

ENGINE OIL

PFP:KLA92

EBS00J9X

ENGINE OIL

Inspection OIL LEVEL

- Before starting the engine make sure the vehicle is parked on a flat and level surface, then check the oil level. If the engine is already running, turn it off and allow 10 minutes before checking.
- Check that the oil level is within the low (L) and high (H) range as indicated on the dipstick.
- If the engine oil level is out of range, add oil as required. Refer to [GI-45, "Recommended Chemical Products and Sealants"](#).

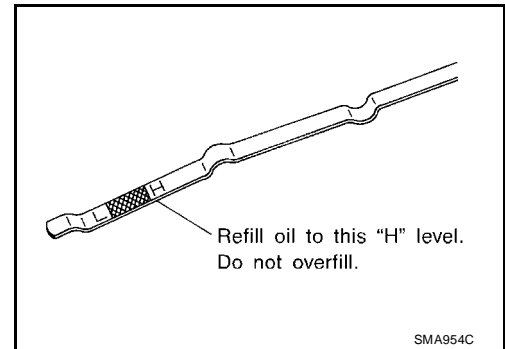

OIL APPEARANCE

- Check the engine oil for a white milky appearance or excessive contamination.
- If the engine oil is milky, it is highly probable that it is contaminated with engine coolant. Repair the broken parts.

OIL LEAKAGE

Check for oil leakage around the following areas.

- Oil pan
- Oil pan drain plug
- Oil pressure sensor
- Oil filter
- Oil cooler
- Intake valve timing control cover
- Intake valve timing control solenoid valve
- Front cover
- Mating surface between cylinder block and cylinder head
- Mating surface between cylinder head and rocker cover
- Crankshaft oil seal (front and rear)

OIL PRESSURE CHECK

WARNING:

- **Be careful not to burn yourself, as engine oil may be hot.**
 - **Put the selector lever in the Park "P" position.**
1. Check the engine oil level. Refer to [LU-7, "OIL LEVEL"](#).
 2. Disconnect the oil pressure sensor harness connector.
 3. Remove oil pressure sensor.
 4. Install Tools.

Tool number : ST25051001 (J-25695-1)
: ST25052000 (J-25695-2)

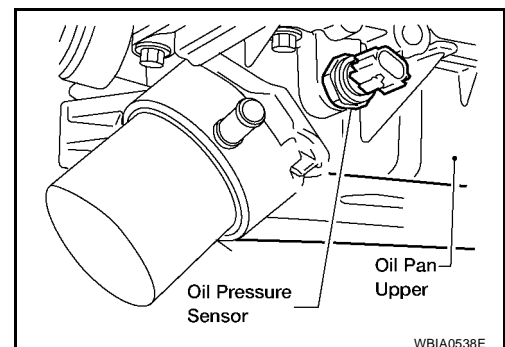

5. Start the engine and warm it up to normal operating temperature.
6. Check the engine oil pressure with engine running under no-load.

ENGINE OIL

Engine oil pressure [Engine oil temperature at 80°C (175°F)]

Unit: kPa (kg/cm², psi)

Engine Speed	Approximate Discharge Pressure
Idle speed	More than 98 (1.0, 14)
2,000 rpm	More than 294 (3.0, 43)

CAUTION:

If the difference is extreme, check the oil passages and oil pump for leaks and blockages.

7. After the inspections, install the oil pressure sensor as follows:
 - a. Remove the old sealant adhering to oil pressure sensor and engine.

Tool number : WS3993000 (-)

Apply thread sealant and tighten the oil pressure sensor to specification using Tool.

- Use Genuine High Performance Thread Sealant, or equivalent. Refer to [GI-45, "Recommended Chemical Products and Sealants"](#).

Oil pressure sensor : 14.8 N·m (1.5 kg-m, 11 ft-lb)

Changing Engine Oil

EBS00J9Y

WARNING:

- Be careful not to burn yourself, as the engine oil is hot.
 - Prolonged and repeated contact with used engine oil may cause skin cancer; try to avoid direct skin contact with used engine oil. If skin contact is made, wash thoroughly with soap or hand cleaner as soon as possible.
1. Remove engine front undercover with power tool.
 2. Warm up engine, and check for oil leakage from engine components.
 3. Stop engine and wait for 10 minutes.
 4. Loosen oil filler cap, then remove drain plug.
 5. Drain engine oil.
 6. Install drain plug with new washer.

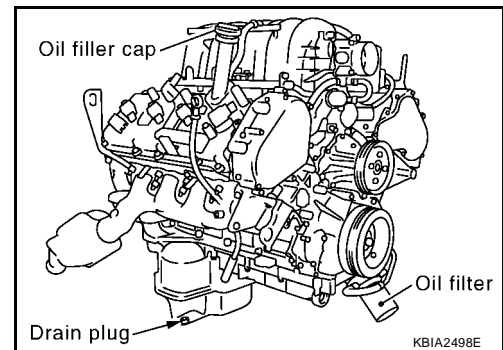

KBIA2498E

CAUTION:

- Be sure to clean drain plug and install with new washer.

Oil pan drain plug : 34.3 N·m (3.5 kg-m, 25 ft-lb)

7. Refill with new engine oil.

Engine oil specification and viscosity:

Refer to [MA-12, "GASOLINE ENGINE OIL"](#).

Engine oil capacity (Approximate):

Unit: ℓ (US qt, Imp qt)

Drain and refill	With oil filter change	6.2 (6 1/2, 5-1/2)
	Without oil filter change	5.9 (6-1/4, 5-1/4)
Dry engine (engine overhaul)		7.6 (8, 6-3/4)

CAUTION:

- The refill capacity depends on the engine oil temperature and drain time. Use these specifications for reference only.
 - Always use the oil level gauge to determine when the proper amount of engine oil is in the engine.
8. Warm up engine and check area around drain plug and oil filter for oil leakage.
 9. Stop engine and wait for 10 minutes.
 10. Check engine oil level and add engine as required. Refer to [LU-7, "OIL LEVEL"](#).

OIL FILTER

PFP:15208

OIL FILTER

Removal and Installation

REMOVAL

1. Remove the engine front undercover with power tool.
2. Remove the oil filter using Tool.

Tool number : KV10115801 (J38956)

CAUTION:

- The oil filter is provided with a relief valve.
Use Genuine NISSAN oil filter or equivalent.
- Be careful not to get burned when the engine and engine oil are hot.
- When removing, prepare a shop cloth to absorb any engine oil leakage or spillage.
- Do not allow engine oil to adhere to the drive belts.
- Completely wipe off any engine oil that adheres to the engine and the vehicle.

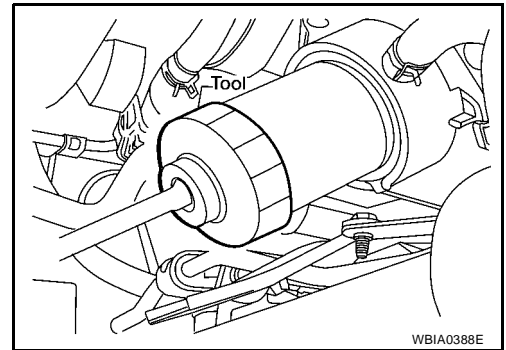

INSTALLATION

1. Remove foreign materials adhering to the oil filter installation surface.
2. Apply engine oil to the oil seal circumference of the new oil filter.

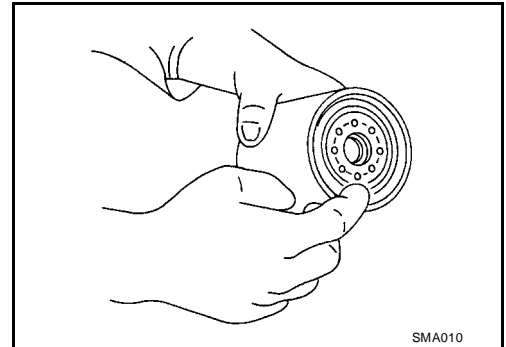

3. Screw the oil filter manually until it touches the installation surface, then tighten it by 2/3 turn. Or tighten to specification.

Oil filter: 17.7 N·m (1.8 kg-m, 13 ft-lb)

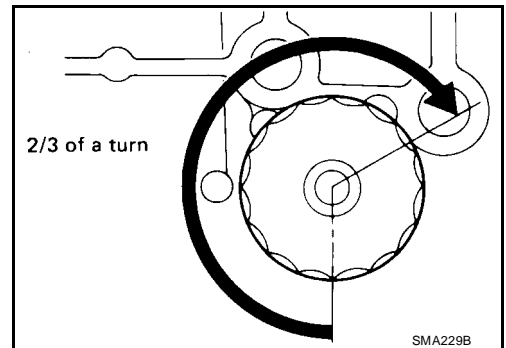

INSPECTION AFTER INSTALLATION

1. After warming up the engine, check for engine oil leakage.
2. Stop engine and wait for 10 minutes.
3. Check engine oil level and add engine oil as required. Refer to [LU-7, "OIL LEVEL"](#) .

OIL COOLER

OIL COOLER

PF2:21305

Removal and Installation

EBS00J9Z

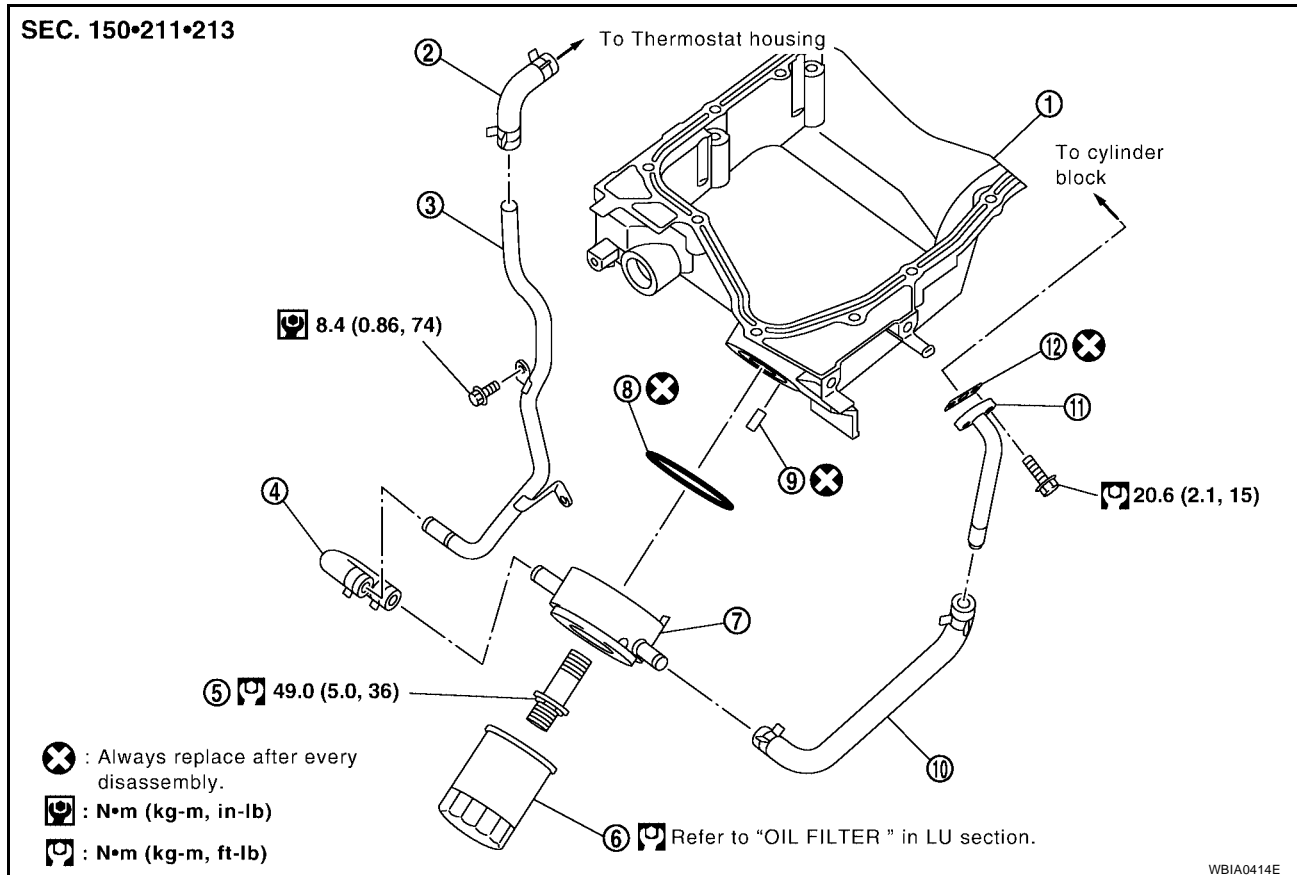

- | | | |
|----------------|--------------------|-----------------|
| 1. Oil pan | 2. Water hose | 3. Water pipe |
| 4. Water hose | 5. Connector bolt | 6. Oil filter |
| 7. Oil cooler | 8. O-ring | 9. Relief valve |
| 10. Water hose | 11. Connector pipe | 12. Gasket |

WARNING:

Be careful not to burn yourself, as the engine oil and engine coolant are hot.

REMOVAL

1. Remove engine front undercover with power tool.
2. Disconnect water hose, pinching hoses near oil cooler to prevent engine coolant from spilling.

CAUTION:

Do not spill engine coolant on the drive belt.

3. Remove oil filter. Refer to [LU-9, "REMOVAL"](#).

CAUTION:

Do not spill engine oil on the drive belts.

4. Remove connector bolt, and remove oil cooler.

INSPECTION AFTER REMOVAL

Oil Cooler

Check oil cooler for cracks. Check oil cooler for clogging by blowing compressed air through engine coolant inlet. If necessary, replace oil cooler assembly.

Relief Valve

Inspect relief valve for movement, cracks and breaks by pushing the ball. If replacement is necessary, remove valve by prying it out with a suitable tool. Install a new valve in place by tapping it.

OIL COOLER

INSTALLATION

Installation is in the reverse order of removal, paying attention to the following:

- Confirm that no foreign objects are adhering to the sealing surfaces of the oil cooler or oil pan.
- Tighten the connecting bolt after aligning the stopper on the oil pan side with protrusion of the oil cooler.

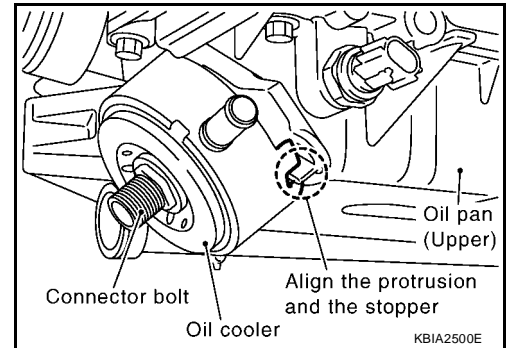

INSPECTION AFTER INSTALLATION

1. Check level of engine oil and engine coolant, and add engine oil and engine coolant. Refer to [LU-7, "OIL LEVEL"](#) and [CO-9, "LEVEL CHECK"](#).
2. Start the engine, and check there is no leak of engine oil or engine coolant.
3. Stop engine and wait for 10 minutes.
4. Check engine oil level and engine coolant level again.

OIL PUMP

PF15010

OIL PUMP

Removal and Installation

EBS0011K

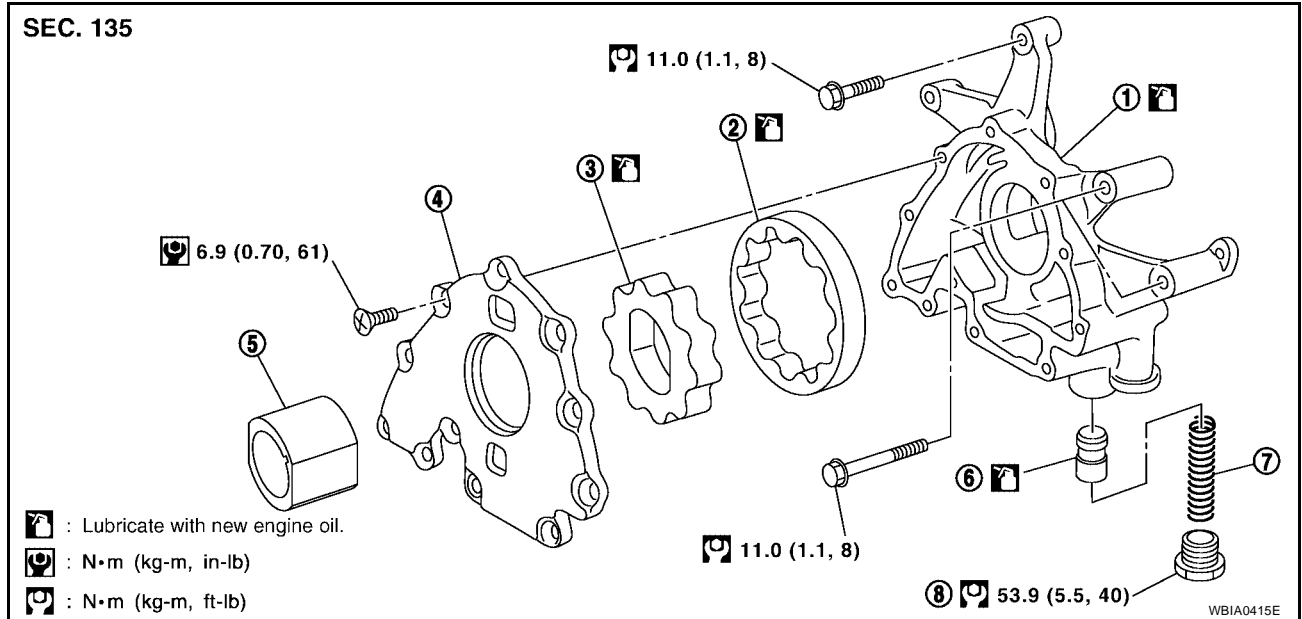

- | | | |
|---------------------|--------------------------|--------------------|
| 1. Oil pump body | 2. Outer rotor | 3. Inner rotor |
| 4. Oil pump cover | 5. Oil pump drive spacer | 6. Regulator valve |
| 7. Regulator spring | 8. Regulator plug | |

REMOVAL

1. Remove front cover. Refer to [EM-36, "REMOVAL"](#).
2. Remove the oil pump drive spacer.
3. Remove the oil pump.

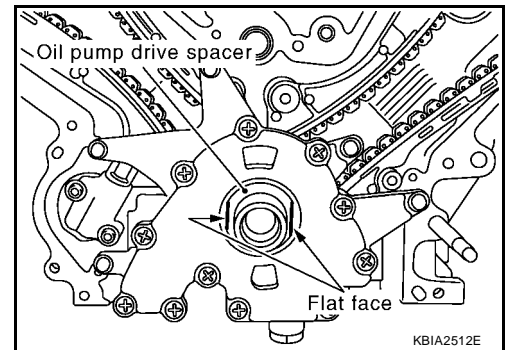

INSTALLATION

1. Installation is in the reverse order of removal, paying attention of the following:
 - When inserting the oil pump drive spacer, align the crankshaft key and the flat face of the inner rotor.
 - If they are not aligned, rotate the oil pump inner rotor by hand.
 - Make sure that the each part is aligned. Using a tool such as a plastic hammer, tap lightly until it reaches the end.

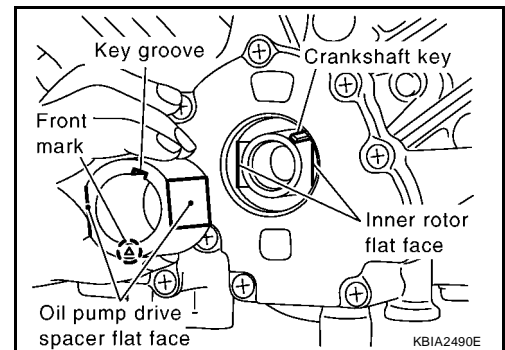

OIL PUMP

INSPECTION AFTER INSTALLATION

- Start the engine, and check there is no leak of engine oil.
- Stop engine and wait 10 minutes.
- Check level of engine oil, and add engine oil as required. Refer to [LU-7, "OIL LEVEL"](#) .

Disassembly and Assembly DISASSEMBLY

EBS001/L

1. Remove oil pump cover.
2. Remove inner rotor and outer rotor from oil pump body.
3. After removing regulator plug, remove regulator spring and regulator valve.

INSPECTION AFTER DISASSEMBLY

Clearance of Oil Pump Parts

- Measure radial clearance with feeler gauge.

Clearance between outer rotor and oil pump body (position 1) : 0.114 - 0.200 mm (0.0045 - 0.0079 in)

Tip clearance between inner rotor and outer rotor (position 2) : Below 0.180 mm (0.0071 in)

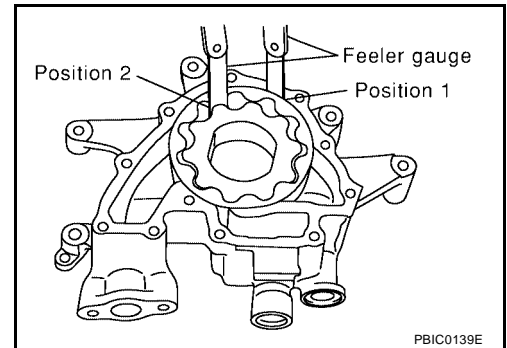

- Measure clearance with feeler gauge and straightedge.

Side clearance between inner rotor and oil pump body (position 3) : 0.030 - 0.070 mm (0.0012 - 0.0028 in)

Side clearance between outer rotor and oil pump body (position 4) : 0.030 - 0.090 mm (0.0012 - 0.0035 in)

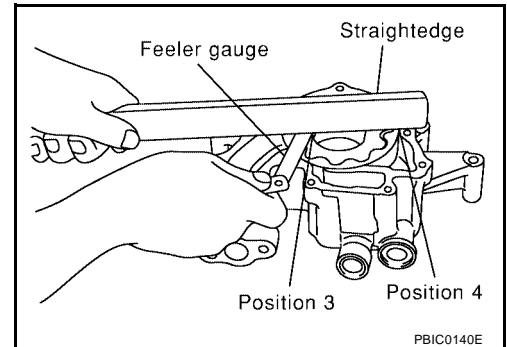

1. Calculate the clearance between inner rotor and oil pump body as follows.

- Measure the outer diameter of protruded portion of inner rotor (position 5)

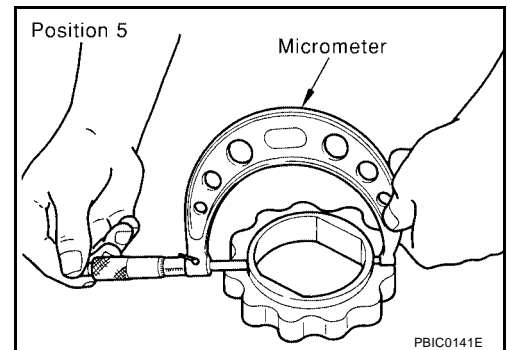

OIL PUMP

- Measure the inner diameter of oil pump body to brazed portion with inside micrometer (position 6)
- (Clearance) = (Inner diameter of oil pump body) – (Outer diameter of inner rotor)

Side clearance of inner rotor of pump body to outer diameter of inner rotor : 0.045 - 0.091 mm (0.0018 - 0.0036 in)

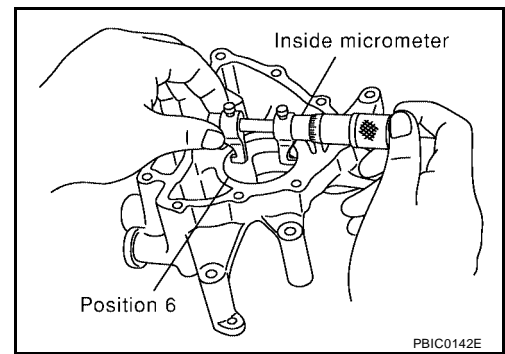

Regulator Valve Clearance

Check regulator valve to oil pump cover clearance as follows:
(Clearance) = D1 (Valve hole diameter) – D2 (Outer diameter of valve)

Regulator valve clearance : 0.040 - 0.097 mm (0.0016 - 0.0038 in)

CAUTION:

- Coat regulator valve with engine oil.
- Check that it falls smoothly into the regulator valve hole by its own weight.

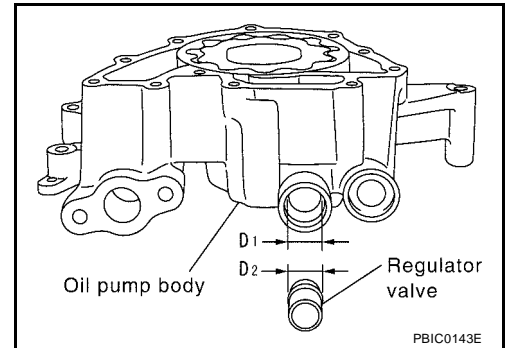

ASSEMBLY

Installation is in the reverse order of removal.

NOTE:

Install the inner rotor and outer rotor with the punched marks on the oil pump cover side.

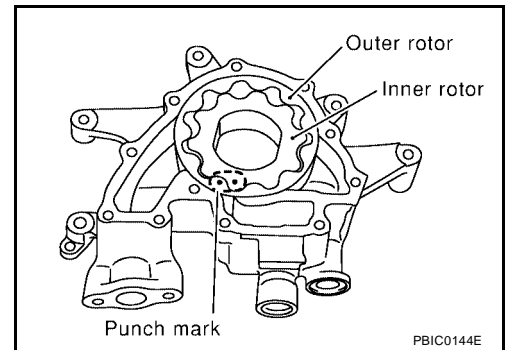

SERVICE DATA AND SPECIFICATIONS (SDS)

SERVICE DATA AND SPECIFICATIONS (SDS)

PFP:00030

Standard and Limit OIL PRESSURE

EBS0011M

Engine speed rpm	Approximate discharge oil pressure kPa (kg/cm ² , psi)
Idle speed 2,000	More than 98 (1.0, 14) More than 294 (3.0, 43)

OIL PUMP

Unit: mm (in)

Body to outer rotor radial clearance	0.114 - 0.200 (0.0045 - 0.0079)
Inner rotor to outer rotor tip clearance	Below 0.180 (0.0071)
Body to inner rotor side clearance	0.030 - 0.070 (0.0012 - 0.0028)
Body to outer rotor side clearance	0.030 - 0.090 (0.0012 - 0.0035)
Inner rotor to brazed portion of housing clearance	0.045 - 0.091 (0.0018 - 0.0036)

REGULATOR VALVE

Unit: mm (in)

Regulator valve to oil pump cover clearance	0.040 - 0.097 (0.0016 - 0.0038)
---	---------------------------------

ENGINE OIL CAPACITY

Unit: ℓ (US qt, Imp qt)

Drain and refill	With oil filter change	6.2 (6 1/2, 5-1/2)
	Without oil filter change	5.9 (6-1/4, 5-1/4)
Dry engine (engine overhaul)		7.6 (8, 6-3/4)

SERVICE DATA AND SPECIFICATIONS (SDS)
