

A  
B  
C  
D  
E

# WW

## SECTION

### WIPER, WASHER & HORN

## CONTENTS

<p><b>PRECAUTION</b> ..... 2</p> <p>    Precautions for Supplemental Restraint System (SRS) "AIR BAG" and "SEAT BELT PRE-TENSIONER" ..... 2</p> <p>    Wiring Diagrams and Trouble Diagnosis ..... 2</p> <p><b>FRONT WIPER AND WASHER SYSTEM</b> ..... 3</p> <p>    Components Parts and Harness Connector Location ..... 3</p> <p>    System Description ..... 3</p> <p>        LOW SPEED WIPER OPERATION ..... 4</p> <p>        HI SPEED WIPER OPERATION ..... 4</p> <p>        INTERMITTENT OPERATION ..... 4</p> <p>        AUTO STOP OPERATION ..... 4</p> <p>        FRONT WASHER OPERATION ..... 5</p> <p>        MIST OPERATION ..... 5</p> <p>        FAIL-SAFE FUNCTION ..... 5</p> <p>        COMBINATION SWITCH READING FUNCTION... 5</p> <p>    CAN Communication System Description ..... 5</p> <p>    Schematic ..... 6</p> <p>    Wiring Diagram — WIPER — ..... 7</p> <p>    Terminals and Reference Values for BCM ..... 10</p> <p>    Terminals and Reference Values for IPDM E/R ..... 11</p> <p>    Work Flow ..... 11</p> <p>    Preliminary Check ..... 12</p> <p>        INSPECTION FOR POWER SUPPLY AND GROUND CIRCUIT ..... 12</p> <p>    CONSULT-II Function (BCM) ..... 13</p> <p>        CONSULT-II OPERATION ..... 13</p> <p>        DATA MONITOR ..... 14</p> <p>        ACTIVE TEST ..... 14</p> <p>    CONSULT-II Function (IPDM E/R) ..... 15</p> <p>        CONSULT-II OPERATION ..... 15</p> <p>        DATA MONITOR ..... 16</p> <p>        ACTIVE TEST ..... 16</p> <p>    Trouble Diagnosis ..... 17</p> <p>        FRONT WIPER DOES NOT OPERATE ..... 17</p> <p>        FRONT WIPER STOP POSITION IS INCORRECT ..... 20</p> <p>        ONLY FRONT WIPER LOW DOES NOT OPERATE ..... 21</p>	<p>        ONLY FRONT WIPER HI DOES NOT OPERATE.. 23</p> <p>        ONLY FRONT WIPER INT DOES NOT OPERATE ..... 24</p> <p>        FRONT WIPER INTERMITTENT OPERATION SWITCH POSITION CANNOT BE ADJUSTED... 25</p> <p>        WIPERS DO NOT WIPE WHEN FRONT WASHER OPERATES ..... 25</p> <p>        FRONT WIPERS OPERATE FOR 10 SECONDS, STOP FOR 20 SECONDS, AND AFTER REPEATING THIS OPERATION FIVE TIMES, THEY BECOME INOPERATIVE ..... 25</p> <p>    Removal and Installation of Front Wiper Arms, Adjustment of Wiper Arms Stop Location ..... 27</p> <p>        REMOVAL ..... 27</p> <p>        INSTALLATION ..... 27</p> <p>    Removal and Installation of Wiper Motor and Linkage ..... 27</p> <p>        REMOVAL ..... 27</p> <p>        INSTALLATION ..... 28</p> <p>    Washer Nozzle Adjustment ..... 28</p> <p>    Washer Tube Layout ..... 29</p> <p>    Removal and Installation of Wiper and Washer Switch ..... 29</p> <p>        REMOVAL ..... 29</p> <p>        INSTALLATION ..... 29</p> <p>    Removal and Installation of Washer Tank ..... 29</p> <p>        REMOVAL ..... 29</p> <p>        INSTALLATION ..... 30</p> <p>    Removal and Installation of Washer Motor ..... 30</p> <p>    <b>POWER SOCKET</b> ..... <b>31</b></p> <p>        Wiring Diagram — P/SCKT — ..... 31</p> <p>        Removal and Installation of Power Sockets ..... 32</p> <p>            REMOVAL ..... 32</p> <p>            INSTALLATION ..... 32</p> <p>    <b>HORN</b> ..... <b>33</b></p> <p>        Wiring Diagram — HORN — ..... 33</p> <p>        Removal and Installation ..... 34</p> <p>            REMOVAL ..... 34</p> <p>            INSTALLATION ..... 34</p>
---	---

WW

# PRECAUTION

## PRECAUTION

PF0:00011

### Precautions for Supplemental Restraint System (SRS) “AIR BAG” and “SEAT BELT PRE-TENSIONER”

EKS007PJ

The Supplemental Restraint System such as “AIR BAG” and “SEAT BELT PRE-TENSIONER”, used along with a front seat belt, helps to reduce the risk or severity of injury to the driver and front passenger for certain types of collision. This system includes seat belt switch inputs and dual stage front air bag modules. The SRS system uses the seat belt switches to determine the front air bag deployment, and may only deploy one front air bag, depending on the severity of a collision and whether the front occupants are belted or unbelted. Information necessary to service the system safely is included in the SRS and SB section of this Service Manual.

#### **WARNING:**

- To avoid rendering the SRS inoperative, which could increase the risk of personal injury or death in the event of a collision which would result in air bag inflation, all maintenance must be performed by an authorized NISSAN/INFINITI dealer.
- Improper maintenance, including incorrect removal and installation of the SRS, can lead to personal injury caused by unintentional activation of the system. For removal of Spiral Cable and Air Bag Module, see the SRS section.
- Do not use electrical test equipment on any circuit related to the SRS unless instructed to in this Service Manual. SRS wiring harnesses can be identified by yellow and/or orange harnesses or harness connectors.

### Wiring Diagrams and Trouble Diagnosis

EKS007PK

When you read wiring diagrams, refer to the following:

- Refer to [GI-14, "How to Read Wiring Diagrams"](#)
- Refer to [PG-4, "POWER SUPPLY ROUTING CIRCUIT"](#) for power distribution circuit.

When you perform trouble diagnosis, refer to the following:

- Refer to [GI-11, "HOW TO FOLLOW TEST GROUPS IN TROUBLE DIAGNOSES"](#)
- Refer to [GI-27, "How to Perform Efficient Diagnosis for an Electrical Incident"](#) .

# FRONT WIPER AND WASHER SYSTEM

PF28810

## FRONT WIPER AND WASHER SYSTEM

### Components Parts and Harness Connector Location

EKS007PL

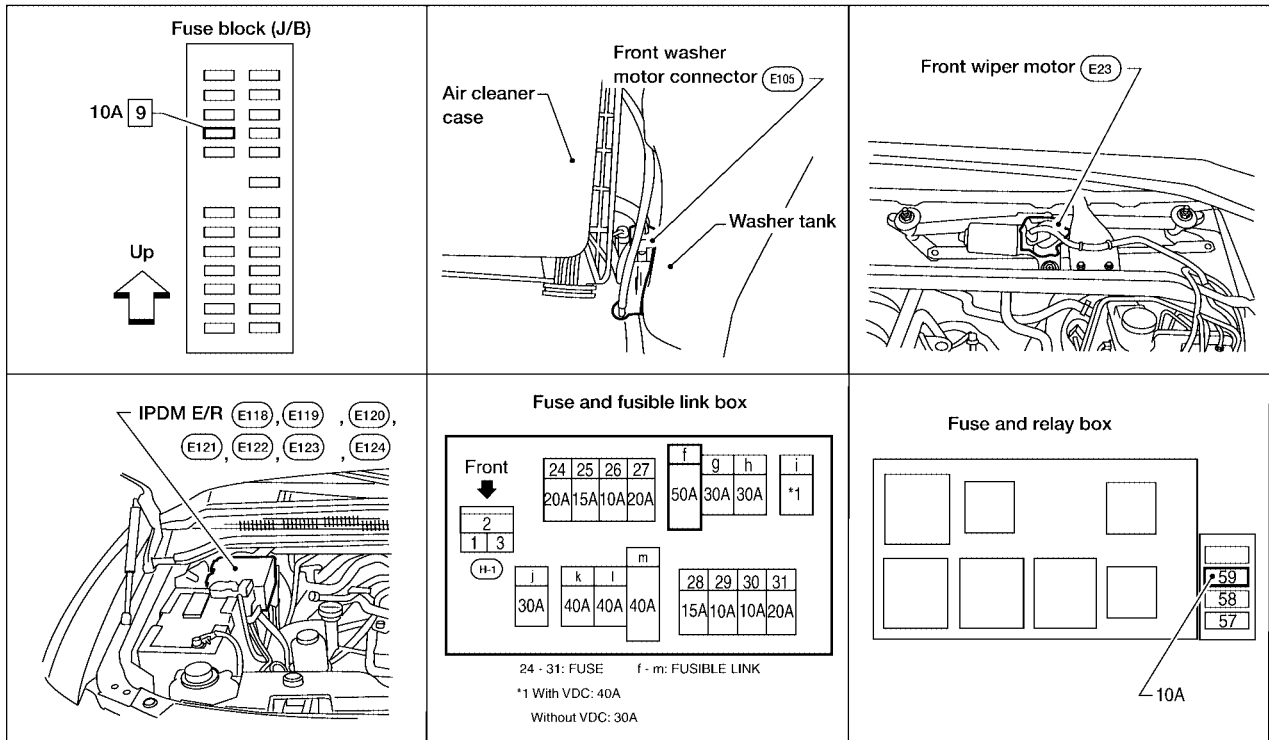

WKIA3869E

## System Description

EKS007PM

- Both front wiper relays are located in IPDM E/R (intelligent power distribution module engine room) .
- The wiper switch (combination switch) is composed of a combination of 5 output terminals and 5 input terminals. Terminal combination status is read by the BCM (body control module) when the wiper switch is turned ON.
- BCM controls front wiper LO, HI, and INT (intermittent) operation.
- IPDM E/R operates the wiper motor according to CAN communication signals from the BCM.

Power is supplied at all times

- through 50A fusible link (letter f , located in the fuse and fusible link box)
- to BCM terminal 70, and
- through 30A fuse (No. 39, located in the IPDM E/R)
- to front wiper relay (located in the IPDM E/R).

With the ignition switch in ON or START position, power is supplied at all times

- through 10A fuse (No. 59, located in the fuse and relay box)
- to BCM terminal 38.

Ground is supplied at all times

- to BCM terminal 67 and
- to combination switch terminal 12
- through grounds M57, M61 and M79, and
- to IPDM E/R terminals 38 and 59 and
- to front wiper motor terminal 1
- through grounds E9, E15 and E24.

A  
B  
C  
D  
E  
F  
G  
H  
I  
J  
L  
M



# FRONT WIPER AND WASHER SYSTEM

---

## LOW SPEED WIPER OPERATION

When the ignition switch is in the ON or START position, and the front wiper switch is turned to the low position, the BCM detects a low speed wiper ON request through the combination switch (wiper switch) reading function.

The BCM then sends a front wiper (low) request signal over CAN communication lines

- from BCM terminals 39 and 40
- to IPDM E/R terminals 39 and 40.

When IPDM E/R receives front wiper (low) request signal, it supplies ground to energize the front wiper relay. With the front wiper relay energized, power is supplied

- through front wiper relay
- through front wiper high relay
- through IPDM E/R terminal 32
- to front wiper motor terminal 3.

With power and ground supplied, the front wiper motor operates at low speed.

## HI SPEED WIPER OPERATION

When the ignition switch is in the ON or START position, and the front wiper switch is turned to the high position, the BCM detects a high speed wiper ON request through the combination switch (wiper switch) reading function.

The BCM then sends a front wiper (high) request signal over CAN communication lines

- from BCM terminals 39 and 40
- to IPDM E/R terminals 39 and 40.

When the IPDM E/R receives a front wiper (high) request signal, it supplies ground to energize the front wiper and the front wiper high relays.

With the front wiper and the front wiper high relays energized, power is supplied

- through front wiper relay
- through front wiper high relay
- through IPDM E/R terminal 35
- to front wiper motor terminal 2.

With power and ground supplied, the front wiper motor operates at high speed.

## INTERMITTENT OPERATION

Wiper intermittent operation delay interval is determined from the combination of the intermittent wiper dial position inputs and vehicle speed. During each intermittent operation delay interval, the BCM sends a front wiper request signal to the IPDM E/R to operate the wipers.

When the ignition switch is in the ON or START position, and the front wiper switch is turned to an intermittent position, the BCM detects a front wiper (intermittent) ON request through the combination switch (wiper switch) reading function.

The BCM then sends a front wiper (intermittent) request signal over CAN communication lines

- from BCM terminals 39 and 40
- to IPDM E/R terminals 39 and 40.

When the BCM determines that combination switch status is front wiper intermittent ON, it performs the following operations.

- BCM detects ON/OFF status of intermittent wiper dial position.
- BCM calculates operation interval from wiper dial position and vehicle speed signal received through CAN communications.
- BCM sends front wiper request signal (INT) to IPDM E/R at calculated operation interval.

When the IPDM E/R receives a front wiper request signal (INT), it supplies ground to energize the front wiper relay. It then sends an auto-stop signal to the BCM, and conducts intermittent front wiper motor operation.

## AUTO STOP OPERATION

When the wiper arms are not located at the base of the windshield, and the wiper switch is turned OFF, the wiper motor will continue to operate until the wiper arms reach the windshield base. When the wiper arms reach the base of windshield, front wiper motor terminals 6 and 1 are connected.

Ground is supplied

# FRONT WIPER AND WASHER SYSTEM

- to IPDM E/R terminal 43
- through front wiper motor terminal 6
- through front wiper motor terminal 1
- through grounds E9, E15 and E24.

The IPDM E/R sends an auto stop operation signal to the BCM through CAN communication lines.

When the BCM receives an auto stop operation signal, the BCM sends wiper stop signal to the IPDM E/R over CAN communication lines. The IPDM E/R then de-energizes the front wiper relay.

The wiper motor will then stop the wiper arms at the STOP position.

## FRONT WASHER OPERATION

When the ignition switch is in the ON or START position, and the front washer switch is OFF, the front washer motor is supplied power

- through 10A fuse (No. 9, located in the fuse block J/B)
- to front washer motor terminal 1.

When the front wiper switch is in the front washer position, the BCM detects a front washer signal request through the combination switch (wiper switch) reading function.

Combination switch ground is supplied

- to front washer motor terminal 2
- through combination switch (wiper switch) terminal 11
- through combination switch (wiper switch) terminal 12
- through grounds M57, M61 and M79.

With ground supplied, the front washer motor operates.

When the BCM detects that front washer motor has operated for 0.4 seconds or longer, the BCM uses CAN communication and sends a wiper request signal to the IPDM E/R for low speed operation of wipers.

When the BCM detects that the washer switch is OFF, low speed operation cycles approximately 3 times and then stops.

## MIST OPERATION

When the wiper switch is temporarily placed in the mist position, wiper low speed operation cycles once and then stops.

For additional information about wiper operation under this condition, refer to [WW-4, "LOW SPEED WIPER OPERATION"](#).

If the switch is held in the mist position, low speed operation continues.

## FAIL-SAFE FUNCTION

The BCM includes fail-safe function to prevent malfunction of electrical components controlled by CAN communications if a malfunction in CAN communications occurs.

The BCM uses CAN communications to stop output of electrical components it controls.

Until the ignition switch is turned off, the front wiper system remains in same status as just before fail-safe control was initiated. (If wiper was in low speed operation just before fail-safe, it continues low speed operation until ignition switch is turned OFF.)

When fail-safe status is initiated, the BCM remains in standby until normal signals are received.

When normal signals are received, fail-safe status is canceled.

## COMBINATION SWITCH READING FUNCTION

Refer to [BCS-3, "COMBINATION SWITCH READING FUNCTION"](#).

## CAN Communication System Description

Refer to [LAN-8, "CAN COMMUNICATION"](#).

EKS007PN

A  
B  
C  
D  
E  
F  
G  
H  
I  
J  
L  
M

WW

# FRONT WIPER AND WASHER SYSTEM

## Schematic

EKS007PO

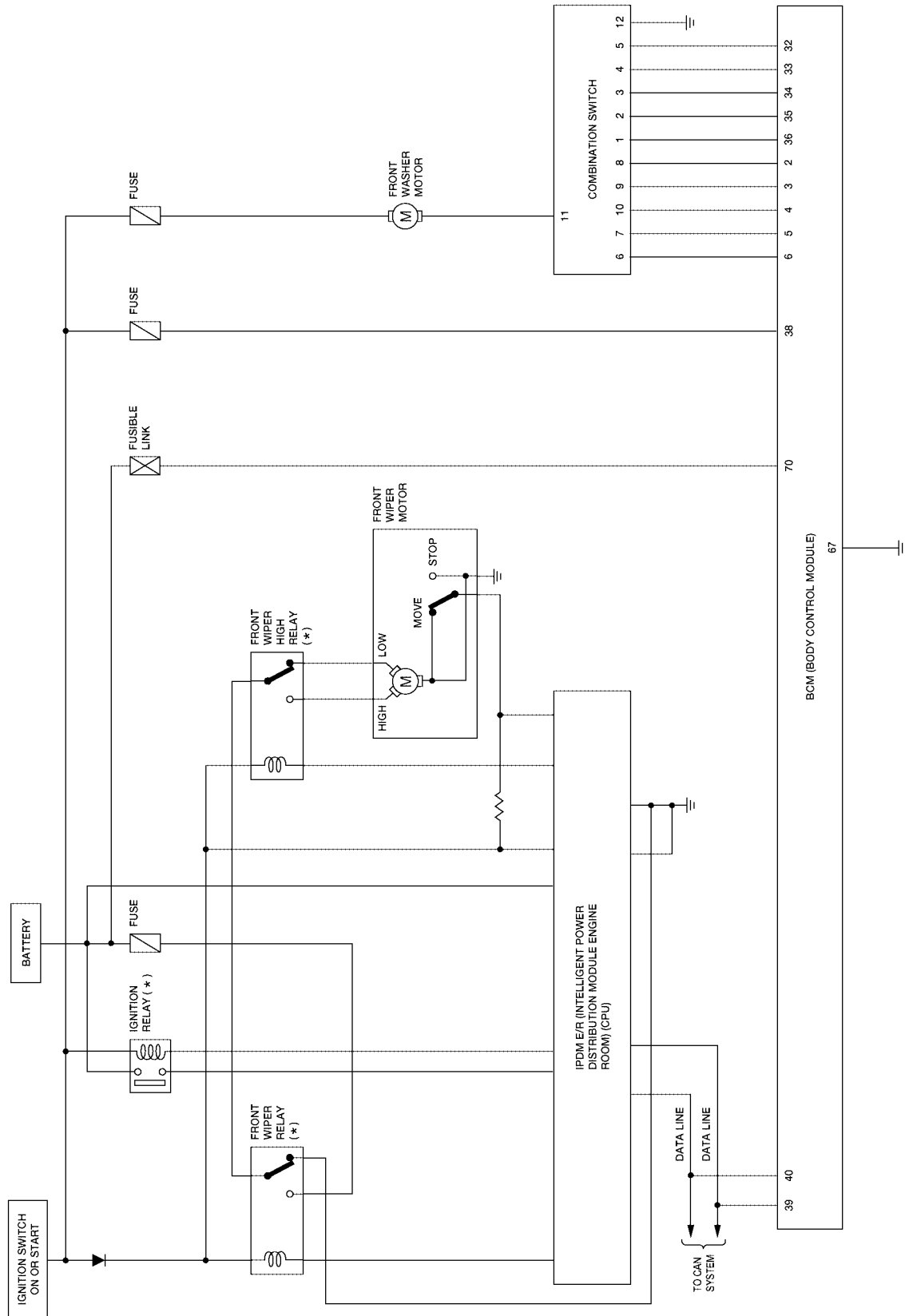

\*: THIS RELAY IS BUILT INTO THE IPDM E/R (INTELLIGENT POWER DISTRIBUTION MODULE ENGINE ROOM).

# FRONT WIPER AND WASHER SYSTEM

## Wiring Diagram — WIPER —

EKS007PP

WW-WIPER-01

— — — — — : DATALINE

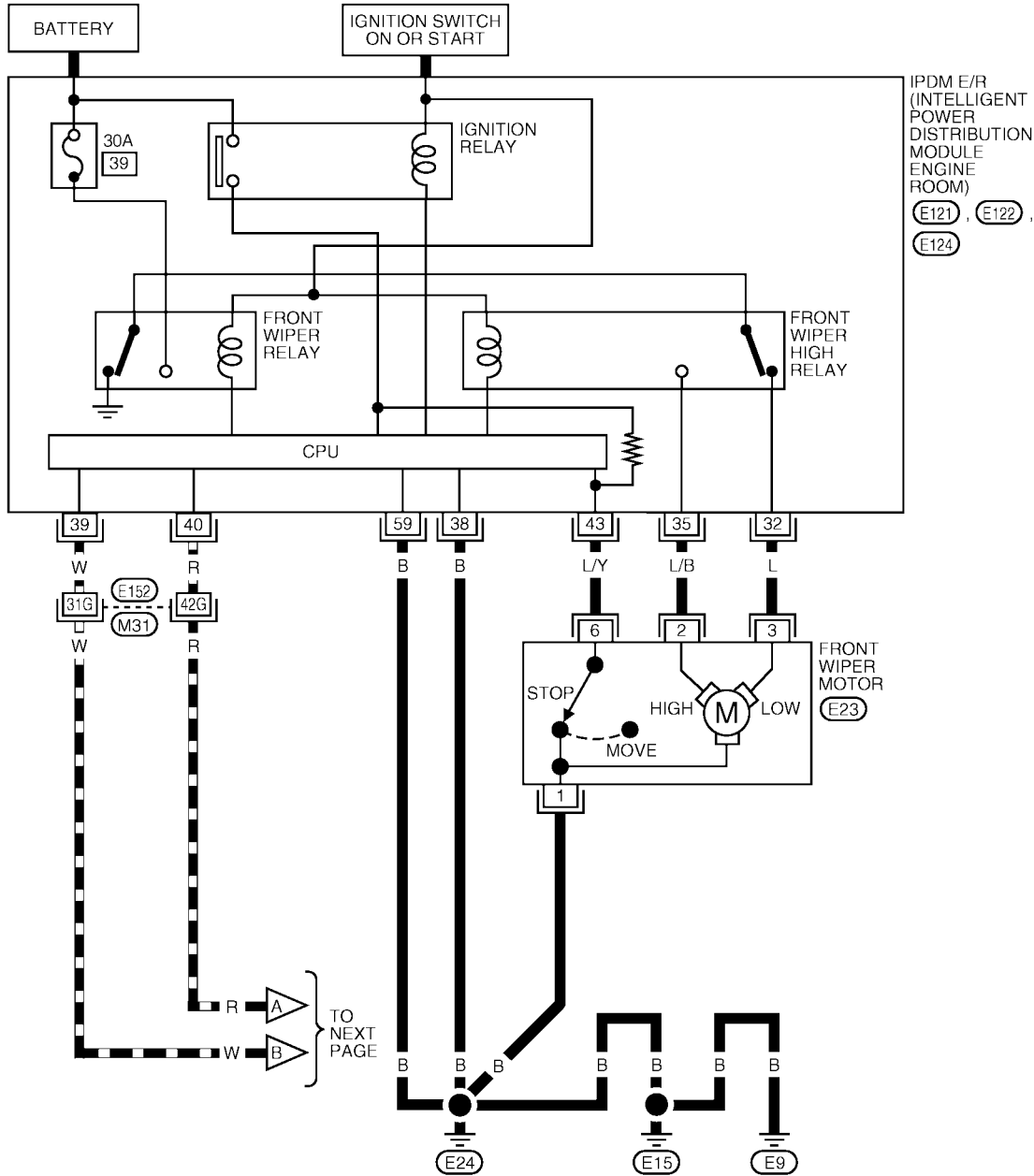

REFER TO "PG-POWER".

A  
B  
C  
D  
E  
F  
G  
H  
I  
J  
L  
M

WW

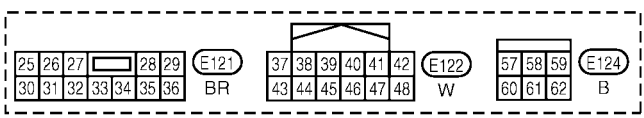
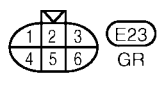

REFER TO THE FOLLOWING.  
 (M31) - SUPER MULTIPLE JUNCTION (SMJ)

WKWA1387E

# FRONT WIPER AND WASHER SYSTEM

WW-WIPER-02

▬ : DATA LINE

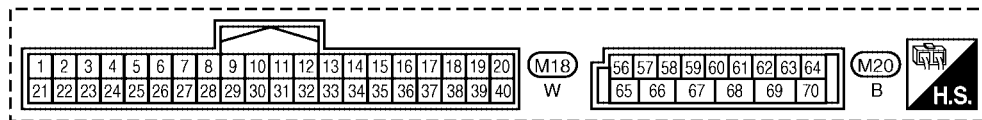
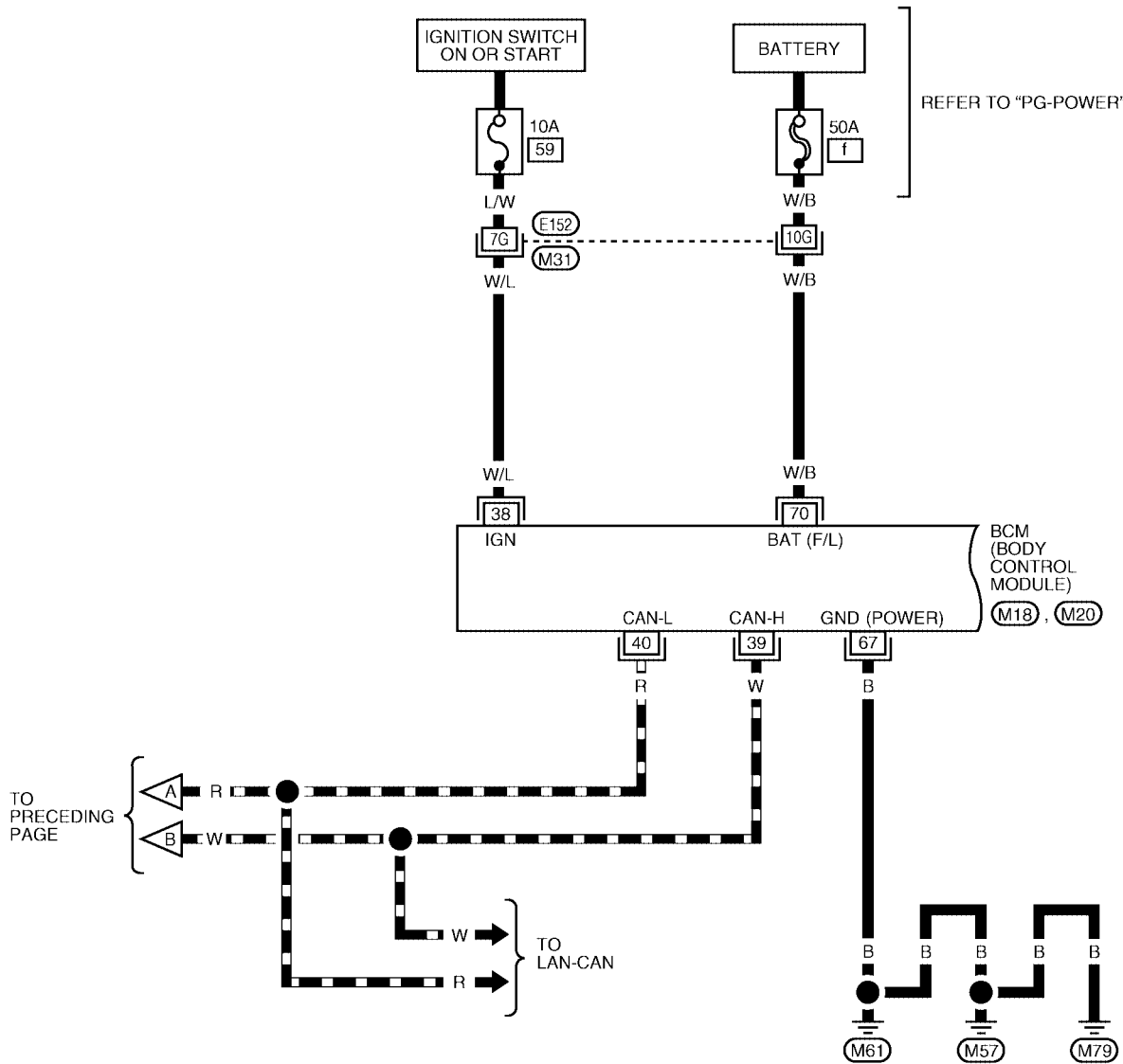

REFER TO THE FOLLOWING.  
 (M31) - SUPER MULTIPLE JUNCTION (SMJ)

WKWA1388E



# FRONT WIPER AND WASHER SYSTEM

WW-WIPER-03

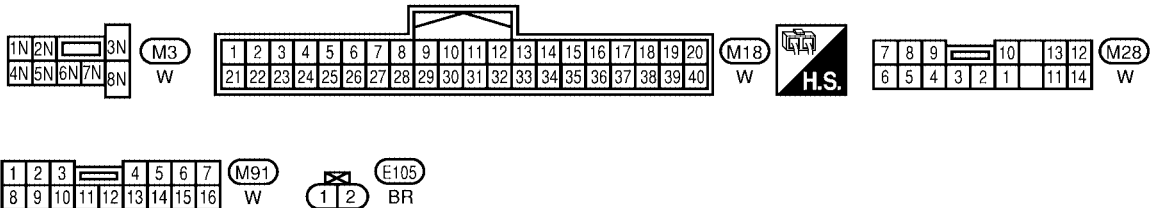
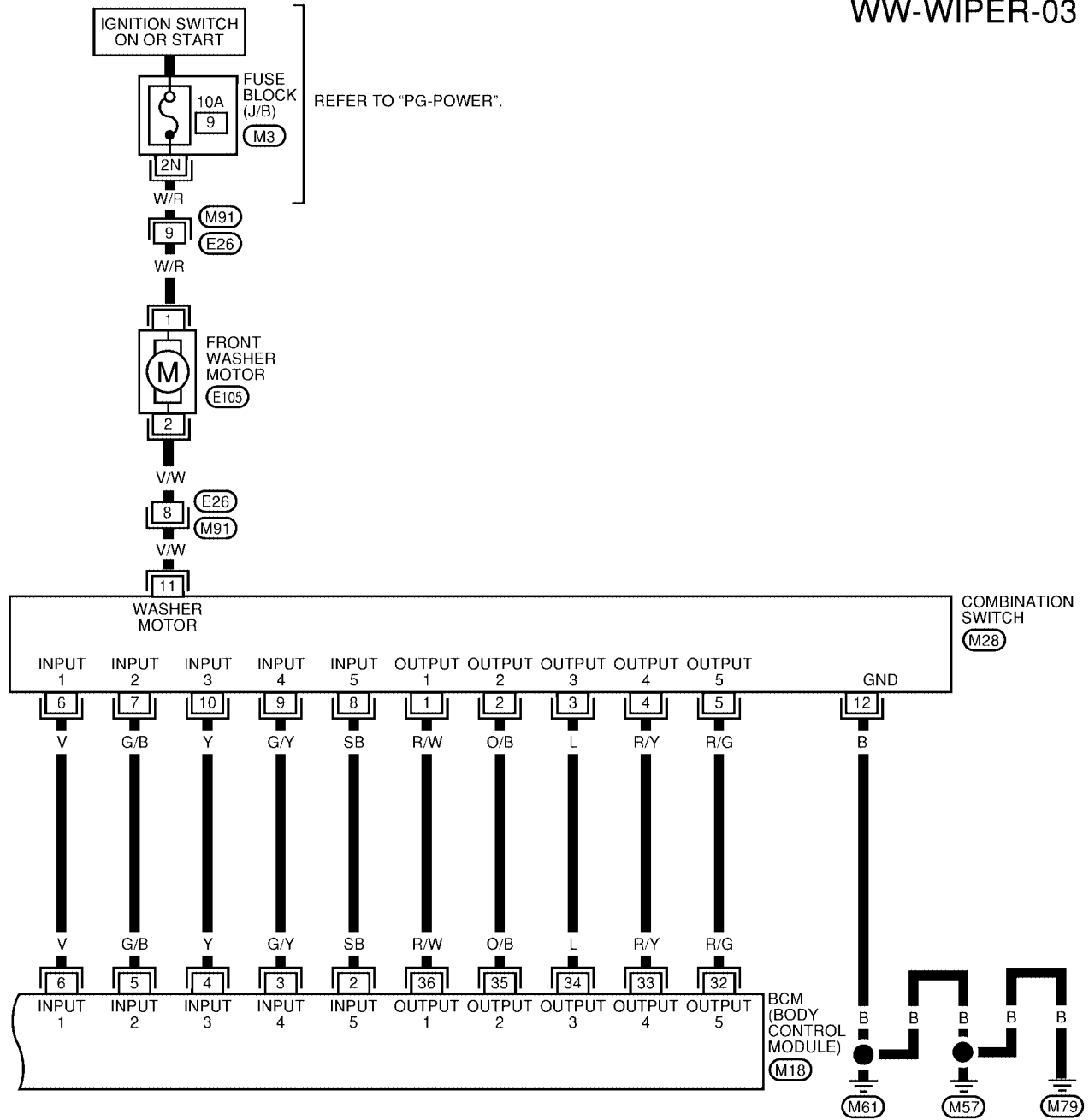





WKWA1006E

# FRONT WIPER AND WASHER SYSTEM

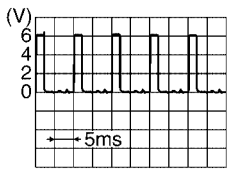
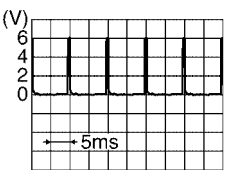
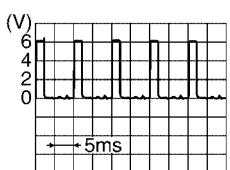
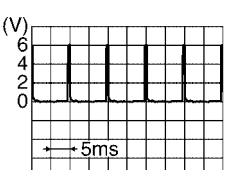
## Terminals and Reference Values for BCM

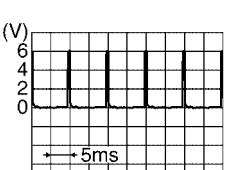
EKS007PQ

Terminal No. (Wire color)	Signal name	Measuring condition		Reference Value (V) (Approx.)
		Ignition switch	Operation or condition	
2 (SB)	Combination switch input 5	ON	<ul style="list-style-type: none"> <li>Light switch and wiper switch OFF</li> <li>Wiper dial position 4</li> </ul>	 <p style="text-align: right;">SKIA5291E</p>
3 (G/Y)	Combination switch input 4	ON	<ul style="list-style-type: none"> <li>Light switch and wiper switch OFF</li> <li>Wiper dial position 4</li> </ul>	 <p style="text-align: right;">SKIA5292E</p>
4 (Y)	Combination switch input 3	ON	<ul style="list-style-type: none"> <li>Light switch and wiper switch OFF</li> <li>Wiper dial position 4</li> </ul>	 <p style="text-align: right;">SKIA5291E</p>
5 (G/B)	Combination switch input 2	ON	<ul style="list-style-type: none"> <li>Light switch and wiper switch OFF</li> <li>Wiper dial position 4</li> </ul>	 <p style="text-align: right;">SKIA5292E</p>
6 (V)	Combination switch input 1	ON		
32 (R/G)	Combination switch output 5	ON	<ul style="list-style-type: none"> <li>Light switch and wiper switch OFF</li> <li>Wiper dial position 4</li> </ul>	 <p style="text-align: right;">SKIA5291E</p>
33 (R/Y)	Combination switch output 4	ON	<ul style="list-style-type: none"> <li>Light switch and wiper switch OFF</li> <li>Wiper dial position 4</li> </ul>	 <p style="text-align: right;">SKIA5292E</p>
34 (L)	Combination switch output 3	ON	<ul style="list-style-type: none"> <li>Light switch and wiper switch OFF</li> <li>Wiper dial position 4</li> </ul>	 <p style="text-align: right;">SKIA5291E</p>

# FRONT WIPER AND WASHER SYSTEM

Terminal No. (Wire color)	Signal name	Measuring condition		Reference Value (V) (Approx.)
		Ignition switch	Operation or condition	
35 (O/B)	Combination switch output 2	ON	<ul style="list-style-type: none"> <li>● Light switch and wiper switch OFF</li> <li>● Wiper dial position 4</li> </ul>	
36 (R/W)	Combination switch output 1			
38 (W/L)	Ignition switch (ON)	ON	—	Battery
39 (W)	CAN-H	ON	—	—
40 (R)	CAN-L	ON	—	—
67 (B)	Ground	—	—	0
70 (W/B)	Battery power	OFF	—	Battery

## Terminals and Reference Values for IPDM E/R

EKS007PR

Terminal No. (Wire color)	Signal name	Measuring condition		Reference value (V) (Approx.)
		Ignition switch	Operation or condition	
32 (L)	Low speed signal	ON	Wiper switch OFF	0
			LO	Battery
35 (L/B)	High speed signal	ON	Wiper switch OFF	0
			HI	Battery
43 (L/Y)	Wiper auto stop signal	ON	Wiper operating	Battery
			Wiper stopped	0
38 (B)	Ground	—	—	0
39 (W)	CAN-H	ON	—	—
40 (R)	CAN-L	ON	—	—
59 (B)	Ground	—	—	0

WW

## Work Flow

EKS007PS

1. Confirm the symptom or customer complaint.
2. Understand the system description, refer to [WW-3, "System Description"](#) .
3. Perform preliminary inspection, refer to [WW-12, "Preliminary Check"](#) .
4. According to the trouble diagnosis chart, repair or replace the cause of the malfunction.
5. Does wiper function operate normally? If it operates normally, GO TO 6. If not, GO TO 4.
6. Inspection End.

# FRONT WIPER AND WASHER SYSTEM

EKS007PT

## Preliminary Check INSPECTION FOR POWER SUPPLY AND GROUND CIRCUIT

Inspection procedure

### 1. CHECK FUSE

Check if wiper or washer fuse is blown.

Unit	Power source	Fuse No.
Front washer motor	Ignition ON or START	9
Front wiper relay	Battery	39
BCM	Ignition ON or START	59
	Battery	f

OK or NG

OK >> GO TO 2.

NG >> If fuse is blown, be sure to eliminate cause of blown fuse before installing new fuse. Refer to [PG-4, "POWER SUPPLY ROUTING CIRCUIT"](#).

### 2. CHECK POWER SUPPLY CIRCUIT

1. Disconnect BCM connectors.
2. Check voltage between BCM harness connector terminals and ground.

Terminals		(-)	Ignition switch position	
(+)			OFF	ON
Connector	Terminal (Wire color)	Ground	0V	Battery voltage
M18	38 (W/L)		Battery voltage	
M20	70 (W/B)			

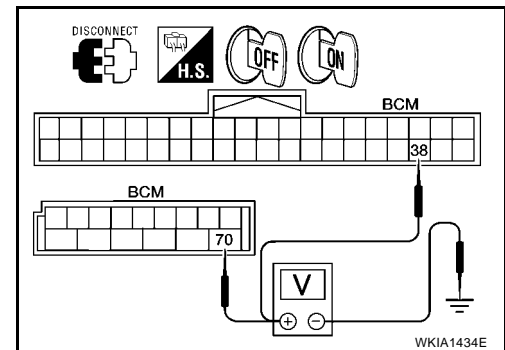

OK or NG

OK >> GO TO 3.

NG >> Check harness for open or short between BCM and fuse.

### 3. GROUND CIRCUIT INSPECTION (BCM)

Check for continuity between BCM terminal and ground.

Terminals			Ignition switch condition	Continuity
Connector	Terminal (wire color)			
M20	67 (B)	Ground	OFF	Yes

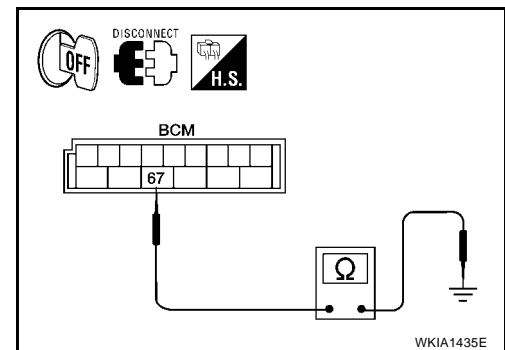

OK or NG

OK >> Inspection End.

NG >> Repair/replace BCM ground circuit.

# FRONT WIPER AND WASHER SYSTEM

## CONSULT-II Function (BCM)

EKS007PU

CONSULT-II can display each diagnostic item using the diagnostic test modes shown following.

BCM diagnostic test item	Diagnostic mode	Description
Inspection by part	WORK SUPPORT	Supports inspections and adjustments. Commands are transmitted to the BCM for setting the status suitable for required operation, input/output signals are received from the BCM and received data is displayed.
	DATA MONITOR	Displays BCM input/output data in real time.
	ACTIVE TEST	Operation of electrical loads can be checked by sending drive signal to them.
	SELF-DIAG RESULTS	Displays BCM self-diagnosis results.
	CAN DIAG SUPPORT MNTR	The result of transmit/receive diagnosis of CAN communication can be read.
	ECU PART NUMBER	BCM part number can be read.
	CONFIGURATION	Performs BCM configuration read/write functions.

## CONSULT-II OPERATION

### CAUTION:

If CONSULT-II is used with no connection of CONSULT-II CONVERTER, malfunctions might be detected in self-diagnosis depending on control unit which carries out CAN communication.

1. With the ignition switch OFF, connect CONSULT-II and CONSULT-II CONVERTER to the data link connector, then turn the ignition switch ON.

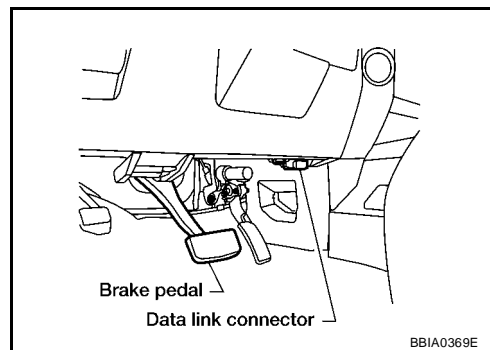

2. Touch "START (NISSAN BASED VHCL)".

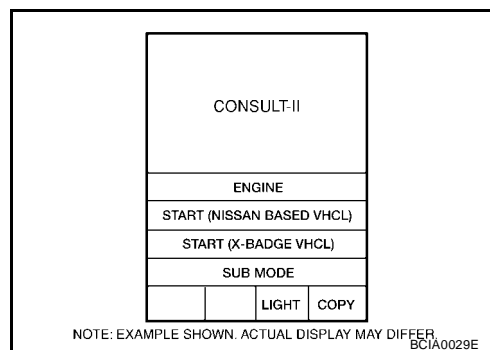

3. Touch "BCM" on the "SELECT SYSTEM" screen. If "BCM" is not indicated, go to [GI-38, "CONSULT-II Data Link Connector \(DLC\) Circuit"](#).

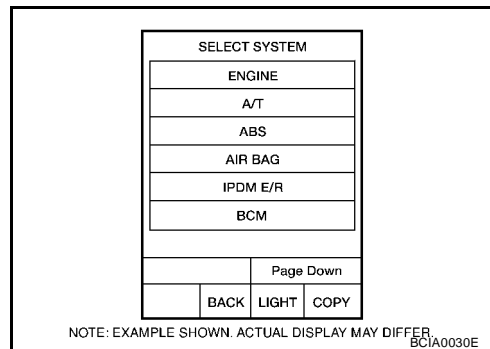

# FRONT WIPER AND WASHER SYSTEM

4. Select the desired part to be diagnosed on the “SELECT TEST ITEM” screen.

SELECT TEST ITEM			
HEAD LAMP			
WIPER			
FLASHER			
AIR CONDITIONER			
COMB SW			
BCM			
Scroll Up		Page Down	
	BACK	LIGHT	COPY

LKIA0183E

## DATA MONITOR

### Operation Procedure

1. Touch “WIPER” on the “SELECT TEST ITEM” screen.
2. Touch “DATA MONITOR” on the “SELECT DIAG MODE” screen.
3. Touch either “ALL SIGNALS” or “SELECTION FROM MENU” on the “SELECT MONITOR ITEM” screen.

ALL SIGNALS	Monitors all the items.
SELECTION FROM MENU	Selects and monitors the individual item selected.

4. Touch “START”.
5. When “SELECTION FROM MENU” is selected, touch items to be monitored. When “ALL SIGNALS” is selected, all the items will be monitored.
6. Touch “RECORD” while monitoring to record the status of the item being monitored. To stop recording, touch “STOP”.

### Display Item List

Monitor item name “OPERATION OR UNIT”	Contents
IGN ON SW      “ON/OFF”	Displays “IGN Position (ON)/OFF, ACC Position (OFF)” status as judged from ignition switch signal.
IGN SW CAN      “ON/OFF”	Displays “IGN switch ON (ON)/Other OFF or ACC (OFF)” status as judged from CAN communications.
FR WIPER HI      “ON/OFF”	Displays “Front Wiper HI (ON)/Other (OFF)” status as judged from wiper switch signal.
FR WIPER LOW    “ON/OFF”	Displays “Front Wiper LOW (ON)/Other (OFF)” status as judged from wiper switch signal.
FR WIPER INT    “ON/OFF”	Displays “Front Wiper INT (ON)/Other (OFF)” status as judged from wiper switch signal.
FR WASHER SW    “ON/OFF”	Displays “Front Washer Switch (ON)/Other (OFF)” status as judged from wiper switch signal.
INT VOLUME      (1 - 7)	Displays intermittent operation dial position setting (1 - 7) as judged from wiper switch signal.
FR WIPER STOP   “ON/OFF”	Displays “Stopped (ON)/Operating (OFF)” status as judged from the auto-stop signal.
VEHICLE SPEED   “0.0 km/h”	Displays vehicle speed as received from CAN communication.

## ACTIVE TEST

### Operation Procedure

1. Touch “WIPER” on the “SELECT TEST ITEM” screen.
2. Touch “ACTIVE TEST” on the “SELECT DIAG MODE” screen.
3. Touch item(s) to be tested and check operation of the selected item(s).
4. During the operation check, touching “BACK” deactivates the operation.

### Display Item List

Test item	Display on CONSULT-II screen	Description
Front wiper HI output	FR WIPER (HI)	Front wiper HI can be operated by any ON-OFF operation.
Front wiper LO output	FR WIPER (LO)	Front wiper LO can be operated by any ON-OFF operation.
Front wiper INT output	FR WIPER (INT)	Front wiper INT can be operated by any ON-OFF operation.

# FRONT WIPER AND WASHER SYSTEM

## CONSULT-II Function (IPDM E/R)

EKS007PV

CONSULT-II can display each diagnostic item using the diagnostic test modes shown following.

IPDM E/R diagnostic Mode	Description
SELF-DIAG RESULTS	Displays IPDM E/R self-diagnosis results.
DATA MONITOR	Displays IPDM E/R input/output data in real time.
CAN DIAG SUPPORT MNTR	The result of transmit/receive diagnosis of CAN communication can be read.
ACTIVE TEST	Operation of electrical loads can be checked by sending drive signal to them.

## CONSULT-II OPERATION

### CAUTION:

If CONSULT-II is used with no connection of CONSULT-II CONVERTER, malfunctions might be detected in self-diagnosis depending on control unit which carries out CAN communication.

1. With the ignition switch OFF, connect CONSULT-II and CONSULT-II CONVERTER to the data link connector, then turn the ignition switch ON.

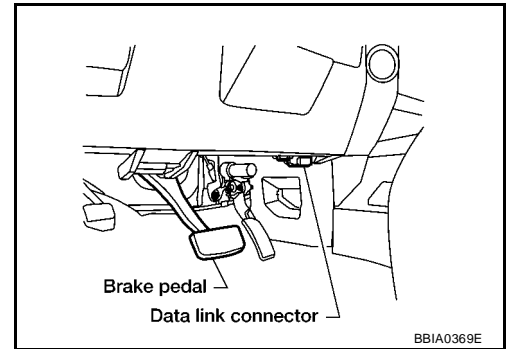

2. Touch "START (NISSAN BASED VHCL)".

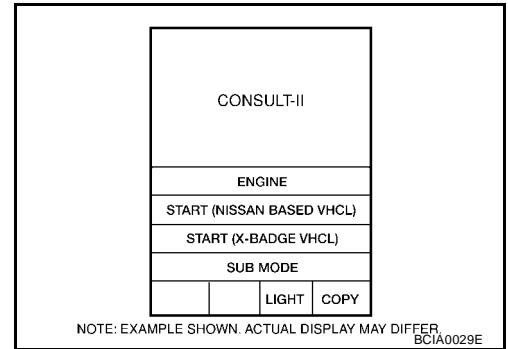

3. Touch "BCM" on the "SELECT SYSTEM" screen. If "BCM" is not indicated, go to [GI-38, "CONSULT-II Data Link Connector \(DLC\) Circuit"](#).

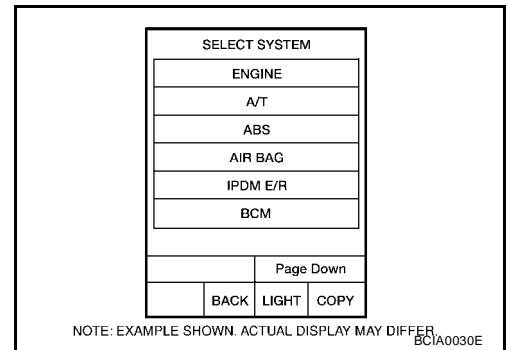

# FRONT WIPER AND WASHER SYSTEM

- Select the desired part to be diagnosed on the "SELECT TEST ITEM" screen.

<b>SELECT TEST ITEM</b>			
HEAD LAMP			
WIPER			
FLASHER			
AIR CONDITIONER			
COMB SW			
BCM			
Scroll Up		Page Down	
BACK	LIGHT	COPY	

LKIA0183E

## DATA MONITOR

### Operation Procedure

- Touch "DATA MONITOR" on the "SELECT DIAG MODE" screen.
- Touch "ALL SIGNALS", "MAIN SIGNALS" or "SELECTION FROM MENU" on the "SELECT MONITOR ITEM" screen.

ALL SIGNALS	Monitors all the items.
MAIN SIGNALS	Monitors predetermined items.
SELECTION FROM MENU	Selects and monitors the individual item selected.

- Touch "START".
- When "SELECTION FROM MENU" is selected, touch items to be monitored. When "ALL SIGNALS" is selected, all the items will be monitored.
- Touch "RECORD" while monitoring to record the status of the item being monitored. To stop recording, touch "STOP".

### All Items, Main Items, Select Item Menu

Item name	CONSULT-II screen display	Display or unit	Monitor item selection			Description
			ALL SIGNALS	MAIN SIGNALS	SELECTION FROM MENU	
Front wiper request	FR WIP REQ	STOP/1LO/LO/HI	x	x	x	Signal status input from BCM.
Wiper auto stop	WIP AUTO STOP	ACT P/STOP P	x	x	x	Output status of IPDM E/R.
Wiper protection	WIP PROT	OFF/LS/HS/BLOCK	x	x	x	Control status of IPDM E/R.

#### NOTE:

Perform monitoring of IPDM E/R data with the ignition switch ON. When the ignition switch is at ACC, the display may not be correct.

## ACTIVE TEST

### Operation Procedure

- Touch "ACTIVE TEST" on the "SELECT DIAG MODE" screen.
- Touch item(s) to be tested and check operation of the selected item(s).
- During the operation check, touching "BACK" deactivates the operation.

### Display Item List

Test item	CONSULT-II screen display	Description
Front wiper (HI, LO) output	FRONT WIPER	With a certain operation (OFF, HI, LO) front wiper relays can be operated.



# FRONT WIPER AND WASHER SYSTEM

## Trouble Diagnosis FRONT WIPER DOES NOT OPERATE

EKS007PW

### CAUTION:

During IPDM E/R fail-safe control, front wipers may not operate. Refer to [PG-16. "CAN COMMUNICATION LINE CONTROL"](#) to make sure that it is not in fail-safe status.

### Inspection Procedure

#### 1. CHECK IPDM E/R TO FRONT WIPERS

Ⓜ With CONSULT-II

1. Select "IPDM E/R" with CONSULT-II, and select "ACTIVE TEST" on "SELECT DIAG MODE" screen.
2. Select "FRONT WIPER" on "SELECT TEST ITEM" screen.

ⓧ Without CONSULT-II

1. Turn on front wipers using auto active test. Refer to [PG-22. "Auto Active Test"](#).
2. Confirm front wiper operation.

OK or NG

- OK >> GO TO 4.  
NG >> GO TO 2.

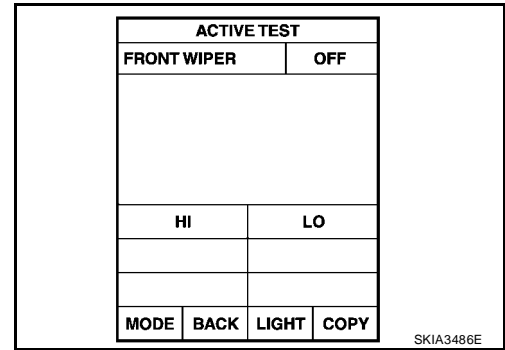

A  
B  
C  
D  
E  
F  
G  
H  
I  
J  
L  
M

WW

# FRONT WIPER AND WASHER SYSTEM

## 2. IPDM E/R TO FRONT WIPERS CIRCUIT INSPECTION

1. Turn ignition switch OFF.
2. Disconnect IPDM E/R connectors and front wiper motor connector.
3. Check continuity between IPDM E/R harness connector terminals and front wiper motor harness connector terminals.

Terminals				Continuity
Connector	Terminal (wire color)	Connector	Terminal (wire color)	
E121	32 (L)	E23	3 (L)	Yes
	35 (L/B)		2 (L/B)	
E122	43 (L/Y)		6 (L/Y)	

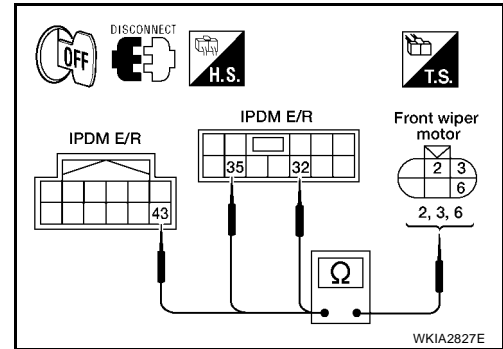

4. Check continuity between IPDM E/R harness connector terminals and ground.

Terminals				Continuity
Connector	Terminal (wire color)			
E121	32 (L)	Ground		No
	35 (L/B)			
E122	43 (L/Y)			

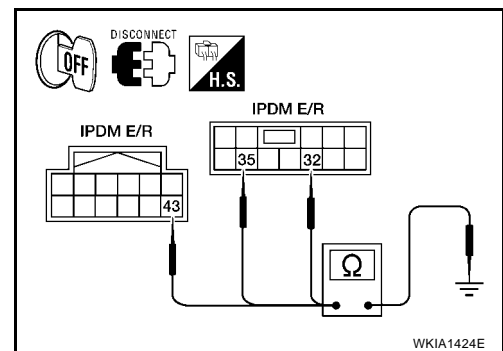

5. Check continuity between IPDM E/R harness connector terminal and ground.

Terminals				Continuity
Connector	Terminal (wire color)			
E122	38 (B)	Ground		Yes
E124	59 (B)			

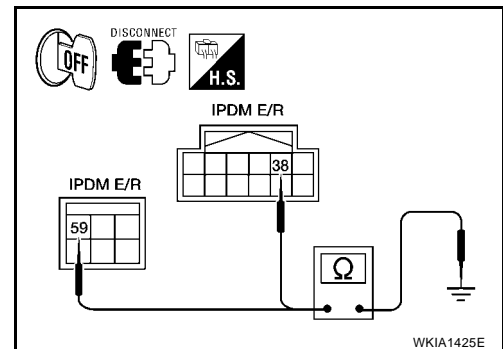

6. Check continuity between front wiper motor harness connector terminal 1 and ground.

Terminals				Continuity
Connector	Terminal (wire color)			
E23	1 (B)	Ground		Yes

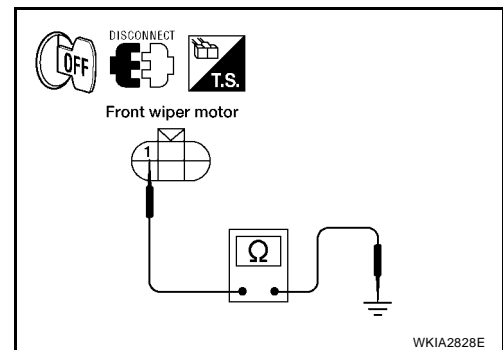

### OK or NG

- OK >> GO TO 3.
- NG >> Check for open circuit in harness between front wiper motor and ground.

# FRONT WIPER AND WASHER SYSTEM

## 3. IPDM E/R INSPECTION

Ⓜ With CONSULT-II

1. Connect IPDM E/R connectors and front wiper motor connector.
2. Select "HI" during "ACTIVE TEST".
3. When front wiper relay, and front wiper high relay are operating, check voltage between IPDM E/R terminals and ground.

ⓧ Without CONSULT-II

1. Connect IPDM E/R connectors and front wiper motor connector.
2. Turn on front wipers using the auto active test. Refer to [PG-22, "Auto Active Test"](#).
3. When front wiper relay, and front wiper high relay are operating, check voltage between IPDM E/R terminals and ground.

Terminals			Condition	Voltage (Approx.)
(+)		(-)		
Connector	Terminal (wire color)			
E121	32 (L)	Ground	Stopped	0
			LO operation	Battery voltage
	35 (L/B)		Stopped	0
			HI operation	Battery voltage

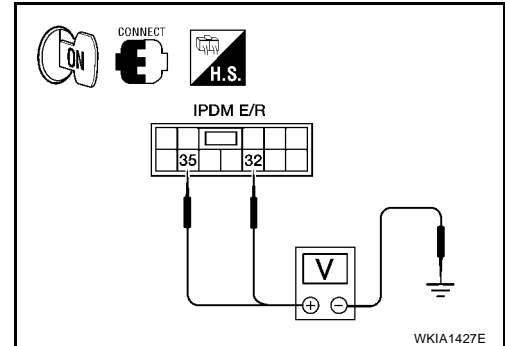

OK or NG

- OK >> Replace the front wiper motor. Refer to [WW-27, "Removal and Installation of Wiper Motor and Linkage"](#).
- NG >> Replace IPDM E/R. Refer to [PG-28, "Removal and Installation of IPDM E/R"](#).

## 4. COMBINATION SWITCH TO BCM INSPECTION

Select "BCM" on CONSULT-II. With "WIPER" data monitor, check that "FR WIPER INT", "FR WIPER LOW" and "FR WIPER HI" turn ON-OFF according to operation of wiper switch.

OK or NG

- OK >> GO TO 5.
- NG >> Check wiper switch. Refer to [BCS-3, "COMBINATION SWITCH READING FUNCTION"](#).

DATA MONITOR	
MONITOR	
IGN ON SW	OFF
IGN SW CAN	ON
FR WIPER HI	OFF
FR WIPER LOW	OFF
FR WIPER INT	OFF
FR WASHER SW	OFF
INT VOLUME	7
FR WIPER STOP	ON
VEHICLE SPEED	0.0 km/h
PAGE DOWN	
RECORD	
MODE	BACK LIGHT COPY

## 5. BCM INSPECTION

Select "BCM" on CONSULT-II. Carry out self-diagnosis of BCM.

Displayed self-diagnosis results

- NO DTC>> Replace BCM. Refer to [BCS-25, "Removal and Installation of BCM"](#).
- CAN COMM CIRCUIT>> Check CAN communication line of BCM. GO TO [BCS-13, "CAN Communication Inspection Using CONSULT-II \(Self-Diagnosis\)"](#).

SELF-DIAG RESULTS			
DTC RESULTS		TIME	
CAN COMM CIRCUIT [U1000]		PAST	
ERASE		PRINT	
MODE	BACK	LIGHT	COPY

# FRONT WIPER AND WASHER SYSTEM

## FRONT WIPER STOP POSITION IS INCORRECT

### Inspection Procedure

#### 1. CHECK IPDM E/R TO FRONT WIPER MOTOR

Ⓜ With CONSULT-II

Select "IPDM E/R" with CONSULT-II. With data monitor, confirm that "WIP AUTO STOP" changes from "ACT P" to "STOP P" according to wiper operation.

ⓧ Without CONSULT-II

GO TO 2.

OK or NG

OK >> Replace IPDM E/R. Refer to [PG-28, "Removal and Installation of IPDM E/R"](#).

NG >> GO TO 2.

DATA MONITOR			
MONITOR			
MOTOR FAN REQ	1		
AC COMP REQ	OFF		
TAIL&CLR REQ	OFF		
HL LO REQ	OFF		
HL HI REQ	OFF		
FR FOG REQ	OFF		
FR WIP REQ	STOP		
WIP AUTO STOP	STOP P		
WIP PROT	OFF		
		Page DOWN	
		RECORD	
MODE	BACK	LIGHT	COPY

SKIA5301E

#### 2. IPDM E/R TO FRONT WIPER MOTOR CIRCUIT INSPECTION

1. Turn ignition switch OFF.
2. Disconnect IPDM E/R connector and front wiper motor connector.
3. Check continuity between IPDM E/R harness connector and front wiper motor harness connector.

Terminals				Continuity
Connector	Terminal (wire color)	Connector	Terminal (wire color)	
E122	43 (L/Y)	E23	6 (L/Y)	Yes

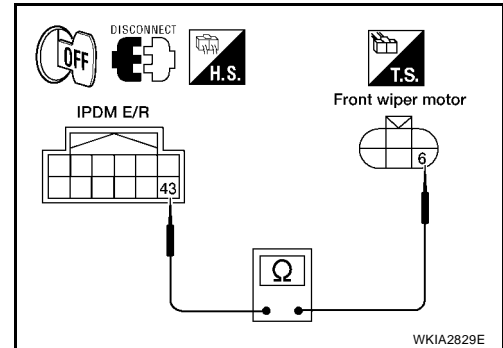

4. Check continuity between IPDM E/R harness connector terminal and ground.

Terminals			Continuity
Connector	Terminal (wire color)	Ground	
E122	43 (L/Y)	Ground	No

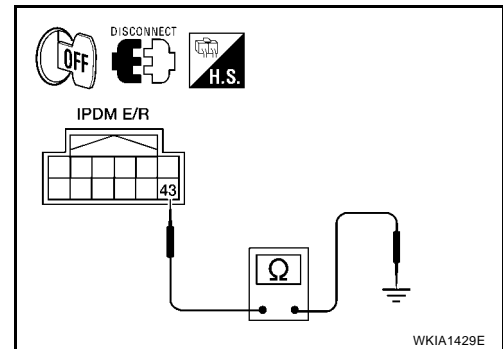

5. Check continuity between front wiper motor harness connector terminal 1 and ground.

Terminals			Continuity
Connector	Terminal (wire color)	Ground	
E23	1 (B)	Ground	Yes

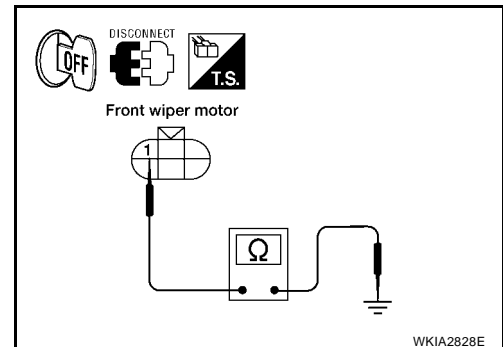

OK or NG

OK >> GO TO 3.

NG >> ● Check for short circuit or open circuit in harness between IPDM E/R and front wiper motor.

- Check for open circuit in harness between front wiper motor and ground.

# FRONT WIPER AND WASHER SYSTEM

## 3. IPDM E/R INSPECTION

Ⓜ With CONSULT-II

1. Connect IPDM E/R connector and front wiper motor connector.
2. Select "LO" during "ACTIVE TEST".
3. When front wipers are operating and when stopped, measure voltage between IPDM E/R terminal 43 and ground.

ⓧ Without CONSULT-II

1. Connect IPDM E/R connector and front wiper motor connector.
2. Turn on front wipers using the auto active test. Refer to [PG-22, "Auto Active Test"](#).
3. When front wipers are operating and when stopped, measure voltage between IPDM E/R terminal 43 and ground.

Terminals		(-)	Condition	Voltage (Approx.)
(+) Connector				
Terminal (wire color)				
E122	43 (L/Y)	Ground	Wiper operating	Fluctuating
			Wiper stopped	0V

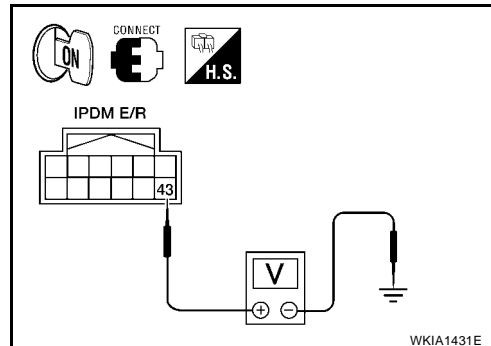

OK or NG

- OK >> Replace IPDM E/R. Refer to [PG-28, "Removal and Installation of IPDM E/R"](#).
- NG >> Replace front wiper motor. Refer to [WW-27, "Removal and Installation of Wiper Motor and Linkage"](#).

### ONLY FRONT WIPER LOW DOES NOT OPERATE

#### Inspection Procedure

#### 1. CHECK IPDM E/R TO FRONT WIPERS

Ⓜ With CONSULT-II

1. Select "IPDM E/R" with CONSULT-II, and select "ACTIVE TEST" on "SELECT DIAG MODE" screen.
2. Select "FRONT WIPER" on "SELECT TEST ITEM" screen.
3. Select "LO" during "ACTIVE TEST".
4. Confirm front wiper low operation.

ⓧ Without CONSULT-II

1. Turn on front wipers using auto active test. Refer to [PG-22, "Auto Active Test"](#).
2. Confirm front wiper low operation.

OK or NG

- OK >> GO TO 4.
- NG >> GO TO 2.

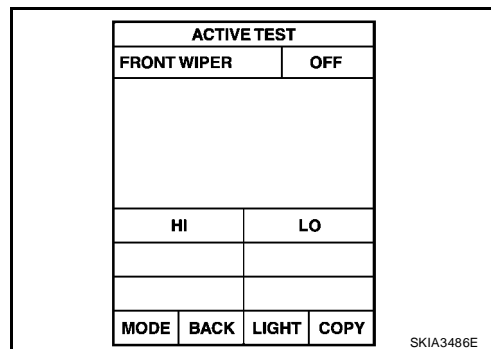

A  
B  
C  
D  
E  
F  
G  
H  
I  
J  
L  
M

WW

# FRONT WIPER AND WASHER SYSTEM

## 2. IPDM E/R TO FRONT WIPERS CIRCUIT INSPECTION

1. Turn ignition switch OFF.
2. Disconnect IPDM E/R connector and front wiper motor connector.
3. Check continuity between IPDM E/R harness connector terminal and front wiper motor harness connector terminal.

Terminals				Continuity
Connector	Terminal (wire color)	Connector	Terminal (wire color)	
E121	32 (L)	E23	3 (L)	Yes

### OK or NG

- OK >> GO TO 3.  
 NG >> Check for short circuit or open circuit in harness between IPDM E/R and front wiper motor.

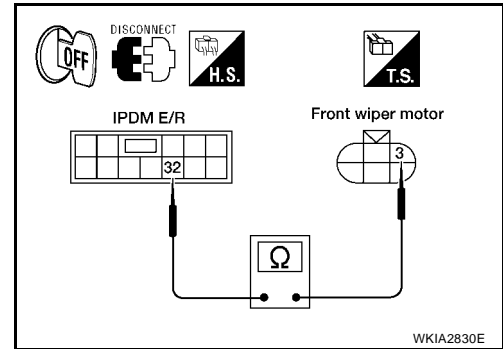

## 3. IPDM E/R INSPECTION

### Ⓜ With CONSULT-II

1. Connect IPDM E/R connector and front wiper motor connector.
2. Select "LO" during "ACTIVE TEST".
3. When front wiper relay is operating, check voltage between IPDM E/R terminals.

### ⓧ Without CONSULT-II

1. Connect IPDM E/R connector and front wiper motor connector.
2. Turn on front wipers using the auto active test. Refer to [PG-22, "Auto Active Test"](#).
3. When front wiper relay is operating, check voltage between IPDM E/R terminals.

Terminals				Voltage (Approx.)
(-)		(+)		
Connector	Terminal (wire color)	Connector	Terminal (wire color)	
E122	38 (B)	E121	32 (L)	Battery voltage
E124	59 (B)			

### OK or NG

- OK >> Replace the wiper motor. Refer to [WW-27, "Removal and Installation of Wiper Motor and Linkage"](#).  
 NG >> Replace IPDM E/R. Refer to [PG-28, "Removal and Installation of IPDM E/R"](#).

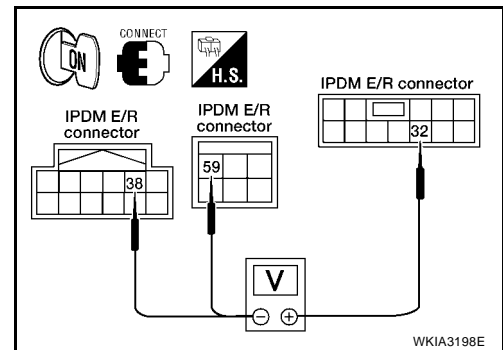

## 4. COMBINATION SWITCH TO BCM INSPECTION

Select "BCM" on CONSULT-II. With "WIPER" data monitor, check that "FR WIPER HI" turns ON-OFF according to operation of wiper switch.

### OK or NG

- OK >> Replace BCM. Refer to [BCS-25, "Removal and Installation of BCM"](#).  
 NG >> Replace wiper switch. Refer to [WW-29, "Removal and Installation of Wiper and Washer Switch"](#).

DATA MONITOR			
MONITOR			
IGN ON SW		OFF	
IGN SW CAN		ON	
FR WIPER HI		OFF	
FR WIPER LOW		OFF	
FR WIPER INT		OFF	
FR WASHER SW		OFF	
INT VOLUME		7	
FR WIPER STOP		ON	
VEHICLE SPEED		0.0 km/h	
		PAGE DOWN	
		RECORD	
MODE	BACK	LIGHT	COPY

# FRONT WIPER AND WASHER SYSTEM

## ONLY FRONT WIPER HI DOES NOT OPERATE

### Inspection Procedure

#### 1. CHECK IPDM E/R TO FRONT WIPERS

Ⓔ With CONSULT-II

1. Select "IPDM E/R" with CONSULT-II, and select "ACTIVE TEST" on "SELECT DIAG MODE" screen.
2. Select "FRONT WIPER" on "SELECT TEST ITEM" screen.
3. Select "HI" during "ACTIVE TEST".
4. Confirm front wiper high operation.

ⓧ Without CONSULT-II

1. Turn on front wipers using auto active test. Refer to [PG-22](#), "Auto Active Test".
2. Confirm front wiper operation.

OK or NG

- OK >> GO TO 4.  
NG >> GO TO 2.

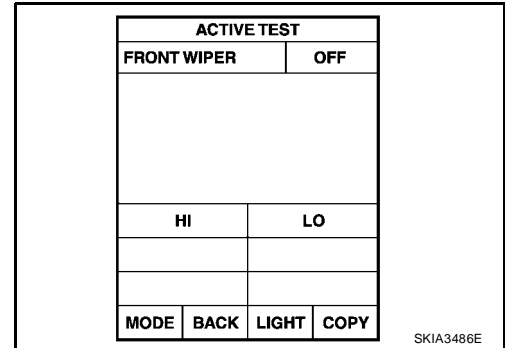

#### 2. IPDM E/R TO FRONT WIPERS CIRCUIT INSPECTION

1. Turn ignition switch OFF.
2. Disconnect IPDM E/R connector and front wiper motor connector.
3. Check continuity between IPDM E/R harness connector terminal and front wiper motor harness connector terminal.

Terminals				Continuity
Connector	Terminal (wire color)	Connector	Terminal (wire color)	
E121	35 (L/B)	E23	2 (L/B)	Yes

OK or NG

- OK >> GO TO 3.  
NG >> Check for short circuit or open circuit in harness between IPDM E/R and front wiper motor.

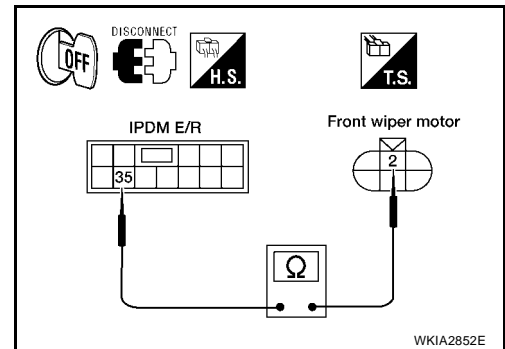

# FRONT WIPER AND WASHER SYSTEM

## 3. IPDM E/R INSPECTION

Ⓜ With CONSULT-II

1. Connect IPDM E/R connector and front wiper motor connector.
2. Select "HI" during "ACTIVE TEST".
3. When front wiper high relay is operating, check voltage between IPDM E/R terminals.

ⓧ Without CONSULT-II

1. Connect IPDM E/R connector and front wiper motor connector.
2. Turn on front wipers using the auto active test. Refer to [PG-22, "Auto Active Test"](#).
3. When front wiper high relay is operating, check voltage between IPDM E/R terminals.

Terminals				Voltage (Approx.)
(-)		(+)		
Connector	Terminal (wire color)	Connector	Terminal (wire color)	
E122	38 (B)	E121	35 (L/B)	Battery voltage
E124	59 (B)			

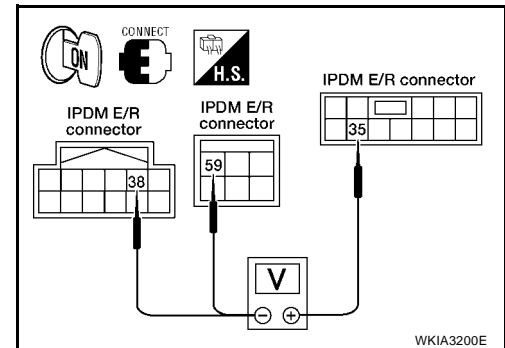

OK or NG

OK >> Replace the wiper motor. Refer to [WW-27, "Removal and Installation of Wiper Motor and Linkage"](#)

NG >> Replace IPDM E/R. Refer to [PG-28, "Removal and Installation of IPDM E/R"](#).

## 4. COMBINATION SWITCH TO BCM INSPECTION

Select "BCM" on CONSULT-II. With "WIPER" data monitor, check that "FR WIPER HI" turns ON-OFF according to operation of wiper switch.

OK or NG

OK >> Replace BCM. Refer to [BCS-25, "Removal and Installation of BCM"](#).

NG >> Replace wiper switch. Refer to [WW-29, "Removal and Installation of Wiper and Washer Switch"](#).

DATA MONITOR	
MONITOR	
IGN ON SW	OFF
IGN SW CAN	ON
FR WIPER HI	OFF
FR WIPER LOW	OFF
FR WIPER INT	OFF
FR WASHER SW	OFF
INT VOLUME	7
FR WIPER STOP	ON
VEHICLE SPEED	0.0 km/h
PAGE DOWN	
RECORD	
MODE	BACK LIGHT COPY

WKIA1018E

### ONLY FRONT WIPER INT DOES NOT OPERATE

#### Inspection Procedure

## 1. COMBINATION SWITCH TO BCM INSPECTION

Select "BCM" on CONSULT-II. With "WIPER" data monitor, check that "FR WIPER INT" turns ON-OFF according to operation of wiper switch.

OK or NG

OK >> Replace BCM. Refer to [BCS-25, "Removal and Installation of BCM"](#).

NG >> Replace wiper switch. Refer to [WW-29, "Removal and Installation of Wiper and Washer Switch"](#).

DATA MONITOR	
MONITOR	
IGN ON SW	OFF
IGN SW CAN	ON
FR WIPER HI	OFF
FR WIPER LOW	OFF
FR WIPER INT	OFF
FR WASHER SW	OFF
INT VOLUME	7
FR WIPER STOP	ON
VEHICLE SPEED	0.0 km/h
PAGE DOWN	
RECORD	
MODE	BACK LIGHT COPY

WKIA1018E



# FRONT WIPER AND WASHER SYSTEM

## FRONT WIPER INTERMITTENT OPERATION SWITCH POSITION CANNOT BE ADJUSTED

### Inspection Procedure

#### 1. COMBINATION SWITCH TO BCM INSPECTION

Select "BCM" on CONSULT-II. With "WIPER" data monitor, check that "INT VOLUME" changes in order from 1 to 7 according to operation of the intermittent switch dial position.

OK or NG

- OK >> Replace BCM. Refer to [BCS-25, "Removal and Installation of BCM"](#).
- NG >> Replace wiper switch. Refer to [WW-29, "Removal and Installation of Wiper and Washer Switch"](#).

DATA MONITOR			
MONITOR			
IGN ON SW		OFF	
IGN SW CAN		ON	
FR WIPER HI		OFF	
FR WIPER LOW		OFF	
FR WIPER INT		OFF	
FR WASHER SW		OFF	
INT VOLUME		7	
FR WIPER STOP		ON	
VEHICLE SPEED		0.0 km/h	
		PAGE DOWN	
RECORD			
MODE	BACK	LIGHT	COPY

WKIA1018E

## WIPERS DO NOT WIPE WHEN FRONT WASHER OPERATES

### Inspection Procedure

#### 1. COMBINATION SWITCH TO BCM INSPECTION

Select "BCM" on CONSULT-II. With "WIPER" data monitor, check that "FR WASHER SW" turns ON-OFF according to operation of front washer switch.

OK or NG

- OK >> Replace BCM. Refer to [BCS-25, "Removal and Installation of BCM"](#).
- NG >> Replace wiper switch. Refer to [WW-29, "Removal and Installation of Wiper and Washer Switch"](#).

DATA MONITOR			
MONITOR			
IGN ON SW		OFF	
IGN SW CAN		ON	
FR WIPER HI		OFF	
FR WIPER LOW		OFF	
FR WIPER INT		OFF	
FR WASHER SW		OFF	
INT VOLUME		7	
FR WIPER STOP		ON	
VEHICLE SPEED		0.0 km/h	
		PAGE DOWN	
RECORD			
MODE	BACK	LIGHT	COPY

WKIA1018E

## FRONT WIPERS OPERATE FOR 10 SECONDS, STOP FOR 20 SECONDS, AND AFTER REPEATING THIS OPERATION FIVE TIMES, THEY BECOME INOPERATIVE

### CAUTION:

- When auto stop signal has not varied for 10 seconds or longer while IPDM E/R is operating front wipers, IPDM E/R considers front wipers locked and stops wiper output, which causes this symptom.
- This status can be checked by using IPDM E/R "DATA MONITOR". Under this condition, "WIP PROT" reads "BLOCK".

### Inspection Procedure

#### 1. CHECK IPDM E/R TO FRONT WIPER MOTOR

☐ With CONSULT-II

Select "IPDM E/R" with CONSULT-II. With data monitor, confirm that "WIP AUTO STOP" changes from "ACT P" to "STOP P" according to wiper operation.

☒ Without CONSULT-II

GO TO 2.

OK or NG

- OK >> Replace IPDM E/R. Refer to [PG-28, "Removal and Installation of IPDM E/R"](#).
- NG >> GO TO 2.

DATA MONITOR			
MONITOR			
MOTOR FAN REQ		1	
AC COMP REQ		OFF	
TAIL&CLR REQ		OFF	
HL LO REQ		OFF	
HL HI REQ		OFF	
FR FOG REQ		OFF	
FR WIP REQ		STOP	
WIP AUTO STOP		STOP P	
WIP PROT		OFF	
		Page DOWN	
RECORD			
MODE	BACK	LIGHT	COPY

SKIA5301E

# FRONT WIPER AND WASHER SYSTEM

## 2. IPDM E/R TO FRONT WIPER MOTOR CIRCUIT INSPECTION

1. Turn ignition switch OFF.
2. Disconnect IPDM E/R connector and front wiper motor connector.
3. Check continuity between IPDM E/R harness connector terminal and front wiper motor harness connector terminal.

Terminals				Continuity
Connector	Terminal (wire color)	Connector	Terminal (wire color)	
E122	43 (L/Y)	E23	6 (L/Y)	Yes

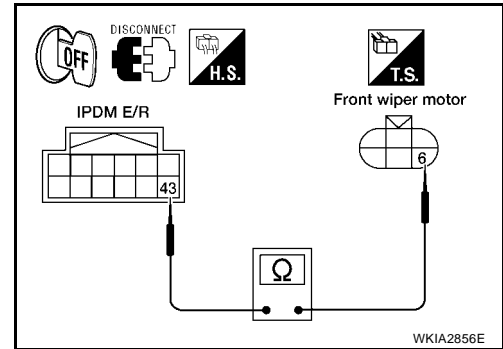

4. Check continuity between IPDM E/R harness connector terminal and ground.

Terminals			Continuity
Connector	Terminal (wire color)		
E122	43 (L/Y)	Ground	No

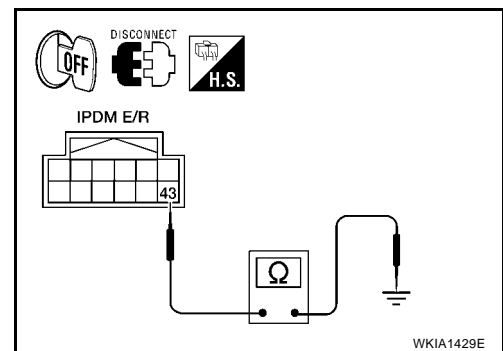

**OK or NG**

- OK >> Connect connectors. GO TO 3.
- NG >> Repair harness or connector.

## 3. IPDM E/R TO FRONT WIPER MOTOR AUTO STOP CIRCUIT INSPECTION

While front wiper motor is stopped and while operating, measure voltage between IPDM E/R terminal 43 and ground.

Terminals				Voltage (Approx.)
(+)		(-)	Condition	
Connector	Terminal (wire color)			
E122	43 (L/Y)	Ground	Wiper operating	Fluctuating
			Wiper stopped	0V

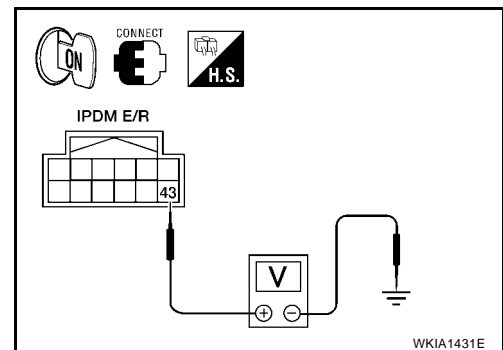

**OK or NG**

- OK >> Replace IPDM E/R. Refer to [PG-28, "Removal and Installation of IPDM E/R"](#) .
- NG >> Replace front wiper motor. Refer to [WW-27, "Removal and Installation of Wiper Motor and Linkage"](#) .

# FRONT WIPER AND WASHER SYSTEM

## Removal and Installation of Front Wiper Arms, Adjustment of Wiper Arms Stop Location

EKS007PX

### REMOVAL

1. Operate the wiper motor, and stop it at the auto stop position.
2. Remove the wiper arm mounting covers.
3. Remove the wiper arm mounting nuts, then remove the wiper arms.

### INSTALLATION

1. Prior to wiper arm installation, turn on wiper switch to operate wiper motor and then turn it "OFF" (Auto Stop).
2. Lift the blade up and then set it down onto glass surface to set the blade center to clearance "L1" and "L2" immediately before tightening nut.
3. Eject washer fluid. Turn on wiper switch to operate wiper motor and then turn it "OFF".
4. Ensure that wiper blades stop within clearance "L1" and "L2".

**Clearance "L1" : 41.5 - 56.5 mm (1.634 - 2.224 in)**

**Clearance "L2" : 52.5 - 67.5 mm (2.067 - 2.657 in)**

- Before reinstalling wiper arm, clean up the pivot area as illustrated. This will reduce possibility of wiper arm looseness.
- Tighten wiper arm nuts to specified torque.

**Front wiper arm nuts : 23.6 N·m (2.4 kg·m, 17 ft·lb)**

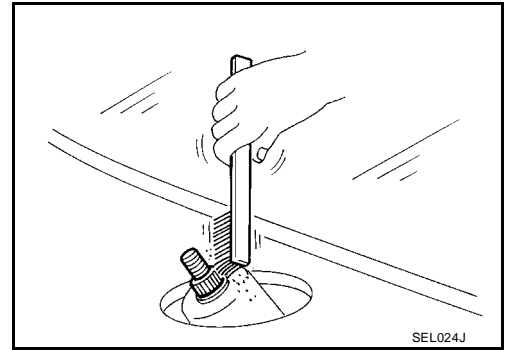
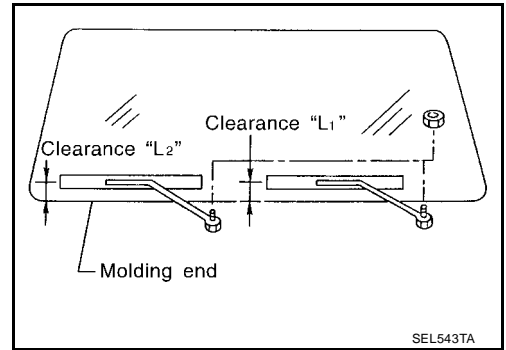

## Removal and Installation of Wiper Motor and Linkage

EKS008XL

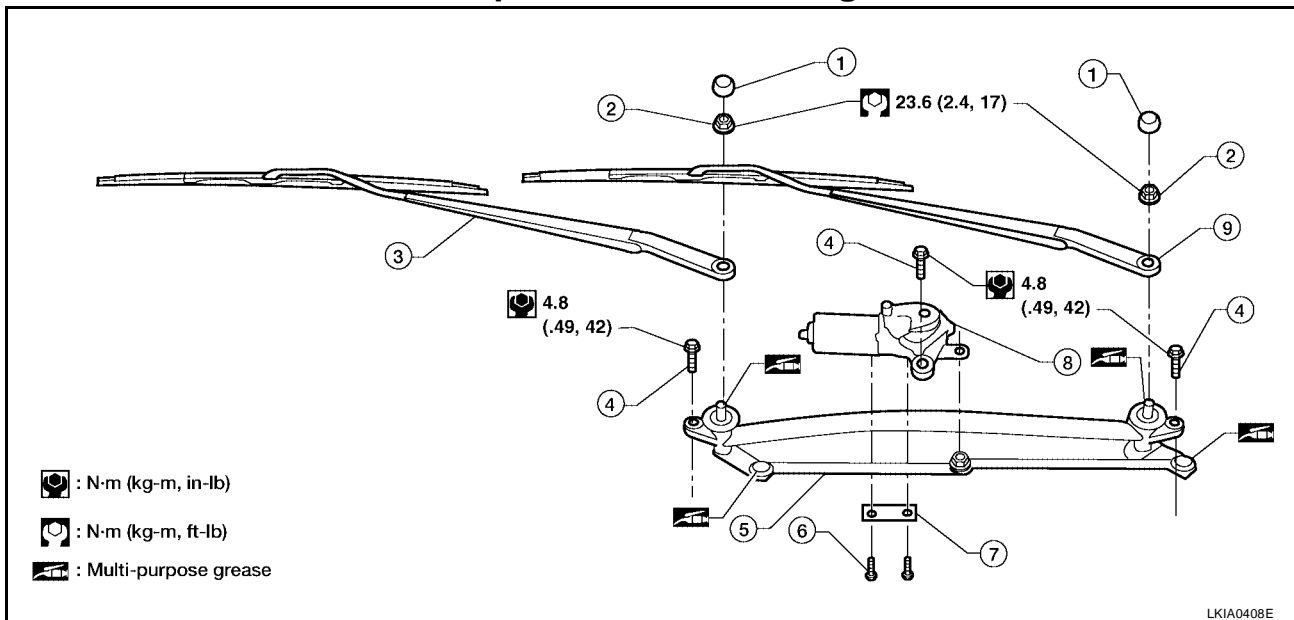

- |                                |                            |  |
|--------------------------------|----------------------------|--|
| 1. Wiper arm mounting covers   | 2. Wiper arm mounting nuts | 3. Front RH wiper arm and blade assembly |
| 4. Wiper frame mounting bolts  | 5. Wiper frame assembly    | 6. Wiper motor to frame mounting bolts   |
| 7. Wiper motor mounting spacer | 8. Wiper motor             | 9. Front LH wiper arm and blade assembly |

### REMOVAL

1. Operate the wiper motor, and stop it at the auto stop position.

A  
B  
C  
D  
E  
F  
G  
H  
I  
J

WW

L  
M

## FRONT WIPER AND WASHER SYSTEM

2. Remove the cowl top RH/LH. Refer to [EI-21, "COWL TOP"](#) .
3. Disconnect wiper motor connector.
4. Remove cowl top extension bracket.
5. Remove wiper frame assembly mounting bolts, and remove wiper frame assembly.
6. Remove wiper motor from wiper frame assembly.

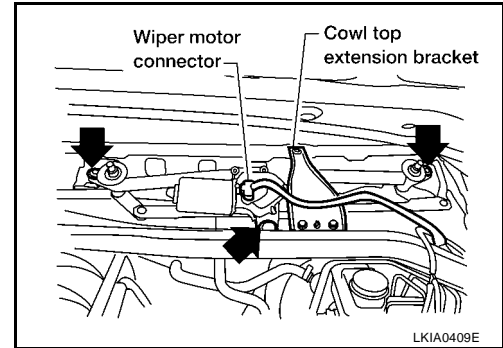

### INSTALLATION

#### CAUTION:

- Do not drop the wiper motor or cause it to contact other parts.
  - Check the grease conditions of the motor arm and wiper link joint(s). Apply grease if necessary.
1. Connect wiper motor to connector. Turn the wiper switch ON to operate wiper motor, then turn the wiper switch OFF (auto stop).
  2. Disconnect wiper motor connector.
  3. Install wiper motor to wiper frame assembly, and install assembly into the vehicle.
  4. Install cowl top extension bracket.
  5. Connect wiper motor connector. Turn the wiper switch ON to operate the wiper motor, then turn wiper switch OFF (auto stop).
  6. Install cowl top RH/LH. Refer to [EI-21, "COWL TOP"](#) .

### Washer Nozzle Adjustment

- This vehicle is equipped with non-adjustable washer nozzles.
- If not satisfied with washer fluid spray coverage, confirm that the washer nozzle is installed correctly.
- If the washer nozzle is installed correctly, and the washer fluid spray coverage is not satisfactory, replace washer nozzle.

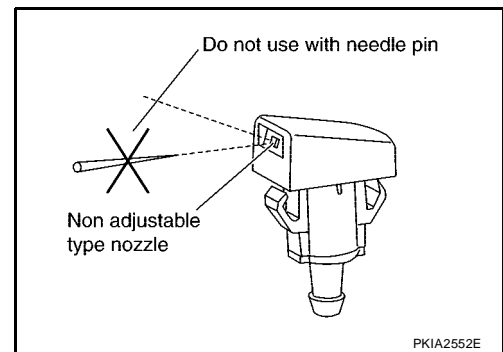

# FRONT WIPER AND WASHER SYSTEM

## Washer Tube Layout

EKS007Q0

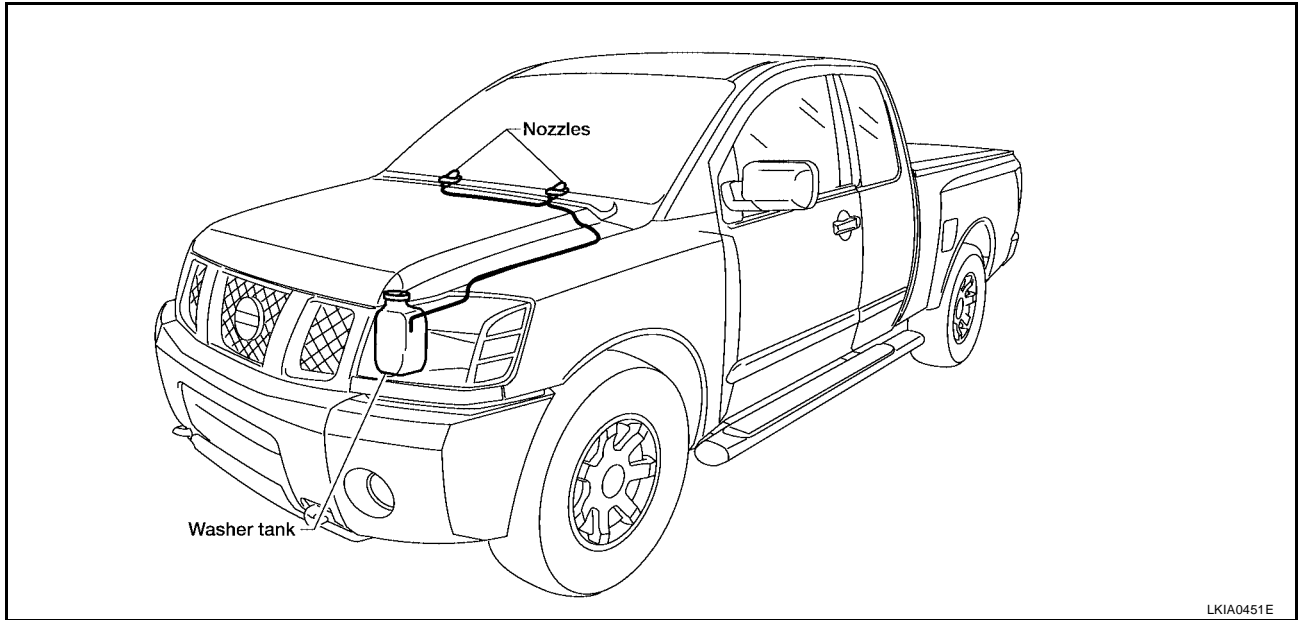

A  
B  
C  
D  
E  
F  
G

## Removal and Installation of Wiper and Washer Switch

EKS007Q1

### REMOVAL

1. Remove steering column covers.
2. Remove wiper washer switch connector.
3. Pinch tabs at wiper and washer switch base and slide switch away from steering column to remove.

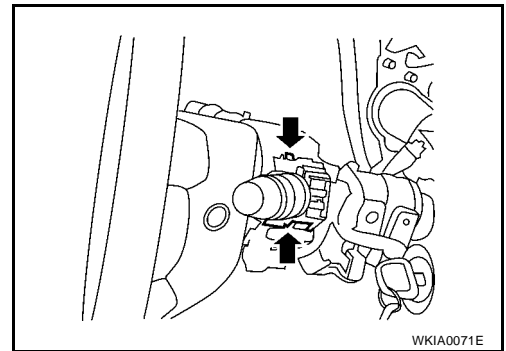

H  
I  
J

### INSTALLATION

Installation is in the reverse order of removal.

## Removal and Installation of Washer Tank

EKS007Q2

### REMOVAL

1. Remove side washer tank screw.

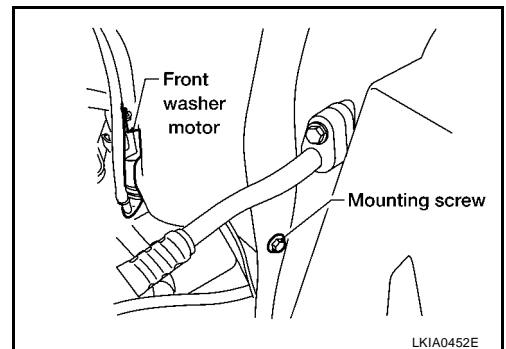

L  
M

WW

# FRONT WIPER AND WASHER SYSTEM

2. Remove front washer motor connector, washer fluid level sensor connector, and front washer hoses.

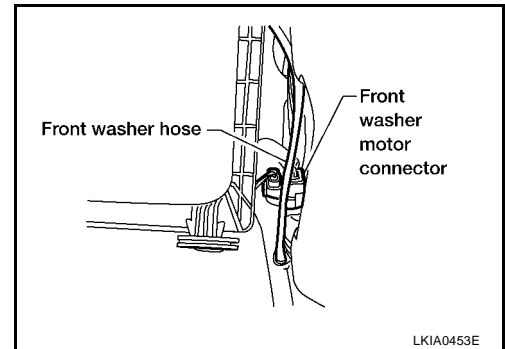

3. Remove front washer tank screw, then remove washer tank.

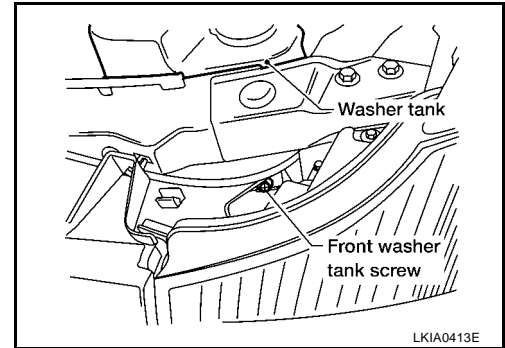

## INSTALLATION

### CAUTION:

After installation, add water up to the upper level of the washer tank inlet, and check for water leaks. Installation is in the reverse order of removal.

Washer tank installation screws : 5.5 N·m (0.56 kg·m, 49 in·lb)

## Removal and Installation of Washer Motor

EKS007Q.3

1. Remove washer tank. Refer to [WW-29, "Removal and Installation of Washer Tank"](#).
2. Pull out front washer motor in the direction of the arrow as shown, and remove the front washer motor from the washer tank.

### CAUTION:

When installing front washer motor, there should be no packing twists, etc.

Installation is in the reverse order of removal.

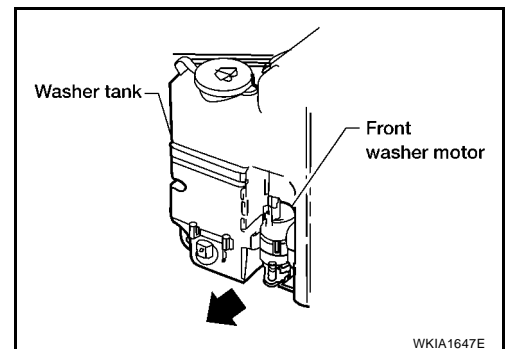

# POWER SOCKET

## POWER SOCKET

### Wiring Diagram — P/SCKT —

PPF:253A2

EKS007Q5

## WW-P/SCKT-01

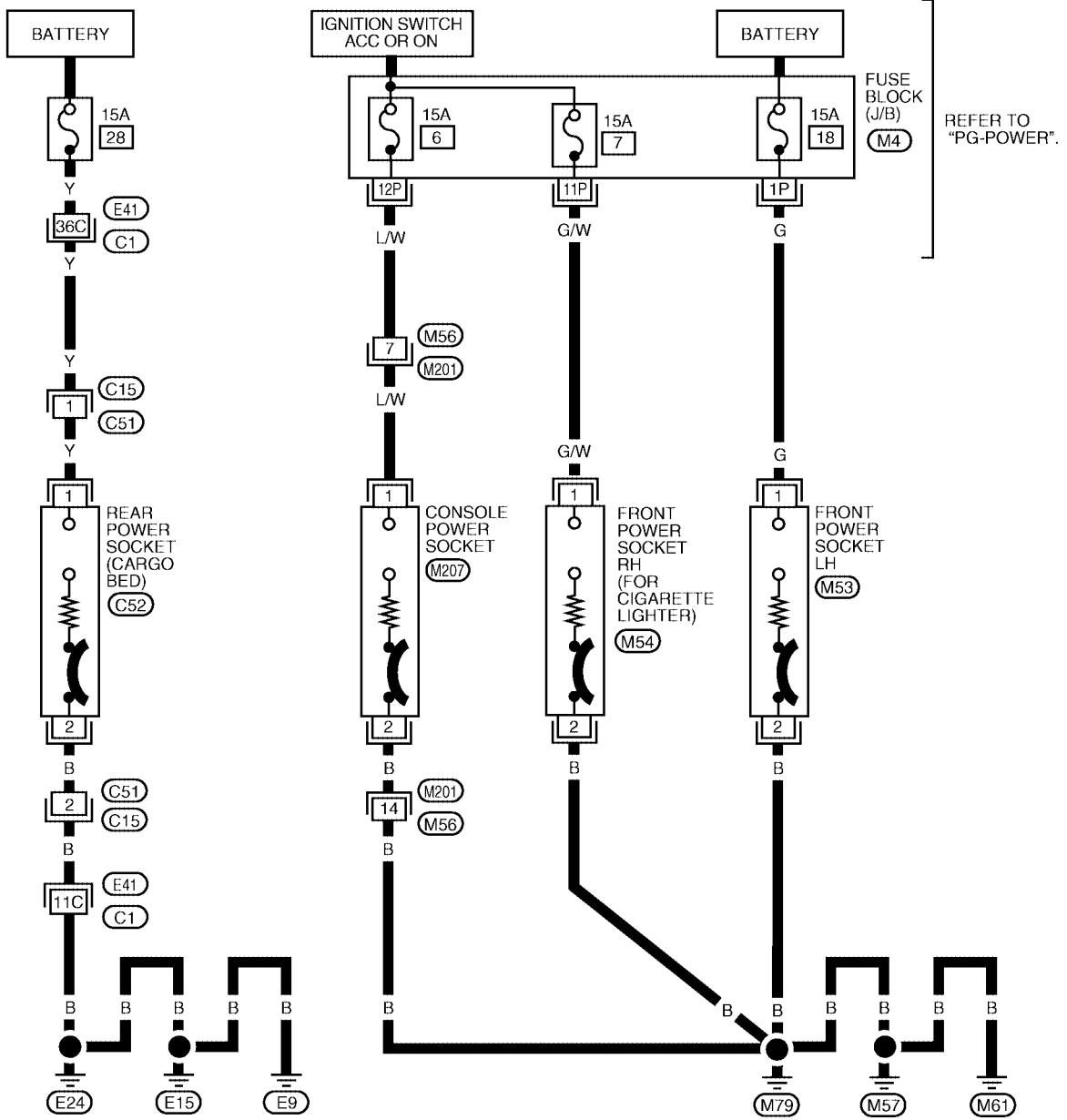

A  
B  
C  
D  
E  
F  
G  
H  
I  
J  
L  
M

WW

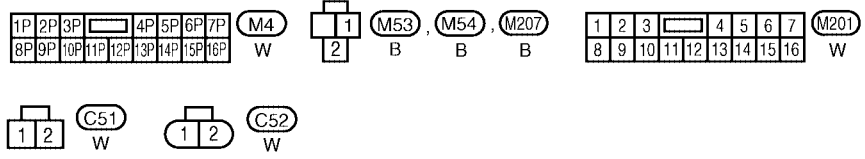

REFER TO THE FOLLOWING.  
C1 - SUPER MULTIPLE JUNCTION (SMJ)

WKWA1535E

# POWER SOCKET

EKS00706

## Removal and Installation of Power Sockets

### REMOVAL

#### NOTE:

Removal and Installation is common for all four power sockets.

1. Remove inner socket from the ring, while pressing the hook on the ring out from square hole.
2. Disconnect power socket connector.
3. Remove ring from power socket finisher while pressing pawls.

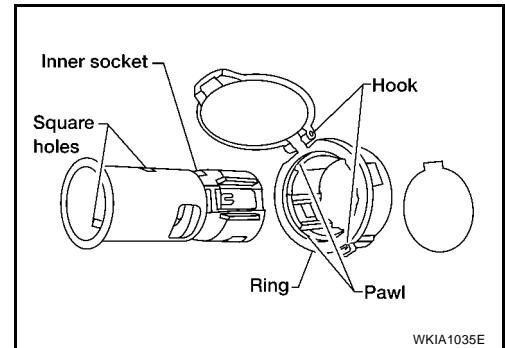

### INSTALLATION

Installation is in reverse order of removal.



# HORN

PFP:25610

EKS007Q7

## HORN

### Wiring Diagram — HORN —

WW-HORN-01

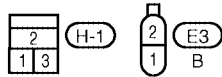
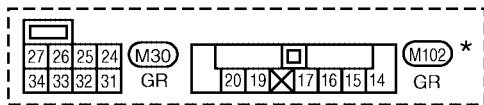
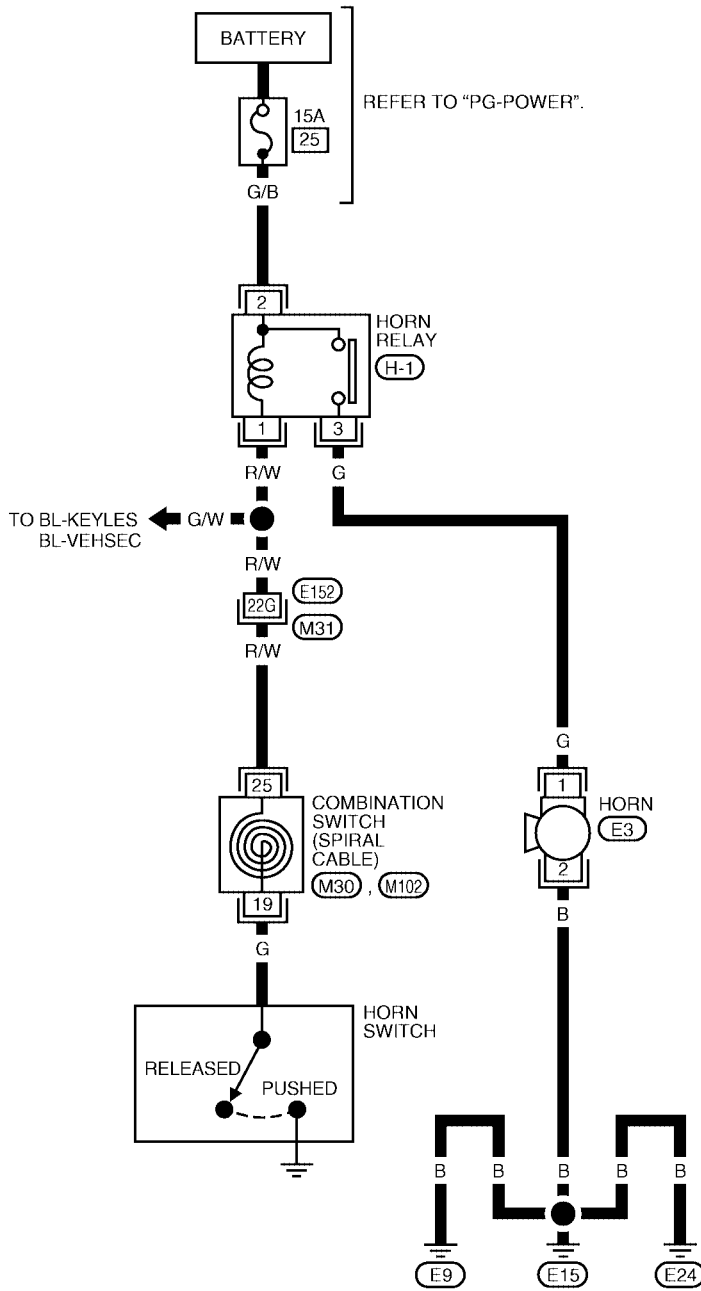

REFER TO THE FOLLOWING.  
 (M31) - SUPER MULTIPLE  
 JUNCTION (SMJ)

\* : This connector is not shown in "HARNESS LAYOUT" of PG section.

WKWA1484E

# HORN

EKS00708

## Removal and Installation

### REMOVAL

1. Remove the front grille. Refer to [EI-20, "FRONT GRILLE"](#) .
2. Disconnect horn connector.
3. Remove horn bolt and remove horn from vehicle.

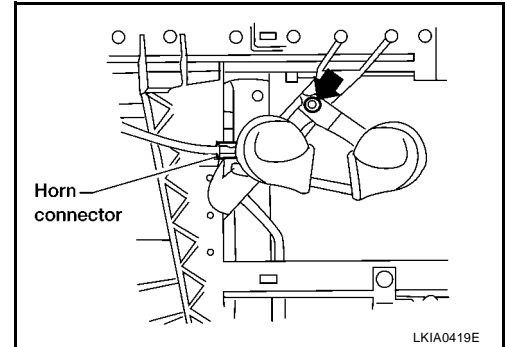

### INSTALLATION

1. Tighten horn bolt to specified torque.  
**Horn bolt : 17 N·m (1.7 kg-m, 13 ft-lb)**
2. Reconnect horn connector.
3. Install front grille. Refer to [EI-20, "FRONT GRILLE"](#) .