

A
B
C

SECTION PR

PROPELLER SHAFT

PR

CONTENTS

<p>PREPARATION 2</p> <p style="padding-left: 20px;">Commercial Service Tools 2</p> <p>NOISE, VIBRATION, AND HARSHNESS (NVH)</p> <p>TROUBLESHOOTING 3</p> <p style="padding-left: 20px;">NVH Troubleshooting Chart 3</p> <p>FRONT PROPELLER SHAFT 4</p> <p style="padding-left: 20px;">On-Vehicle Service 4</p> <p style="padding-left: 40px;">PROPELLER SHAFT VIBRATION 4</p> <p style="padding-left: 40px;">INSPECTION 4</p> <p style="padding-left: 20px;">Removal and Installation 4</p> <p style="padding-left: 40px;">REMOVAL 5</p> <p style="padding-left: 40px;">INSPECTION AFTER REMOVAL 5</p> <p style="padding-left: 40px;">INSTALLATION 5</p> <p style="padding-left: 20px;">Disassembly and Assembly 5</p> <p style="padding-left: 40px;">DISASSEMBLY 5</p> <p style="padding-left: 40px;">ASSEMBLY 6</p>	<p>REAR PROPELLER SHAFT 8</p> <p style="padding-left: 20px;">On-Vehicle Service 8</p> <p style="padding-left: 40px;">PROPELLER SHAFT VIBRATION 8</p> <p style="padding-left: 40px;">INSPECTION 8</p> <p style="padding-left: 20px;">Removal and Installation 8</p> <p style="padding-left: 40px;">REMOVAL 9</p> <p style="padding-left: 40px;">INSPECTION AFTER REMOVAL 10</p> <p style="padding-left: 40px;">INSTALLATION 10</p> <p style="padding-left: 20px;">Disassembly and Assembly 11</p> <p style="padding-left: 40px;">DISASSEMBLY 11</p> <p style="padding-left: 40px;">ASSEMBLY 12</p> <p>SERVICE DATA AND SPECIFICATIONS (SDS) 15</p> <p style="padding-left: 20px;">General Specifications 15</p> <p style="padding-left: 20px;">Snap Ring 15</p>	<p>E</p> <p>F</p> <p>G</p> <p>H</p> <p>I</p> <p>J</p> <p>K</p> <p>L</p> <p>M</p>
---	--	--

PREPARATION

PREPARATION

PFP:00002

Commercial Service Tools

EDS00100

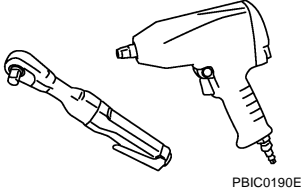
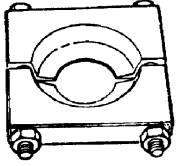
Tool name	Description
<p data-bbox="154 296 267 323">Power tool</p>  <p data-bbox="862 514 933 533">PBIC0190E</p>	<p data-bbox="1010 296 1263 323">Loosening bolts and nuts</p>
<p data-bbox="154 575 305 632">205-D002 Bearing splitter</p>  <p data-bbox="862 779 933 798">ZZA0700D</p>	<p data-bbox="1010 575 1344 602">Removing center support bearing</p>

NOISE, VIBRATION, AND HARSHNESS (NVH) TROUBLESHOOTING

NOISE, VIBRATION, AND HARSHNESS (NVH) TROUBLESHOOTING

PF0:0003

NVH Troubleshooting Chart

EDS00101

Use the chart below to help you find the cause of the symptom. If necessary, repair or replace these parts.

Symptom		Possible cause and suspected parts										
		Uneven rotation torque	Rotation imbalance	Excessive run out	Differential	Axle	Suspension	Tires	Road wheel	Drive shaft	Brakes	Steering
Noise	Noise	x	x	x	x	x	x	x	x	x	x	x
	Shake					x	x	x	x	x	x	x
	Vibration	x	x	x		x	x	x		x		x

x: Applicable

A
B
C
PR
E
F
G
H
I
J
K
L
M

FRONT PROPELLER SHAFT

PF3:37200

FRONT PROPELLER SHAFT

On-Vehicle Service PROPELLER SHAFT VIBRATION

EDS00102

NOTE:

If a vibration is present at high speed, inspect the propeller shaft runout first.

1. Measure the runout of the propeller shaft tube at several points by rotating the final drive companion flange with your hands.

Propeller shaft runout limit : 0.6 mm (0.024 in) or less

2. If the runout still exceeds specifications, disconnect the propeller shaft at the final drive companion flange; then rotate the companion flange 90°, 180°, 270° degrees and reconnect the propeller shaft.
3. Check the runout again. If the runout still exceeds specifications, replace the propeller shaft assembly.
4. After installation, check for vibration by driving the vehicle.

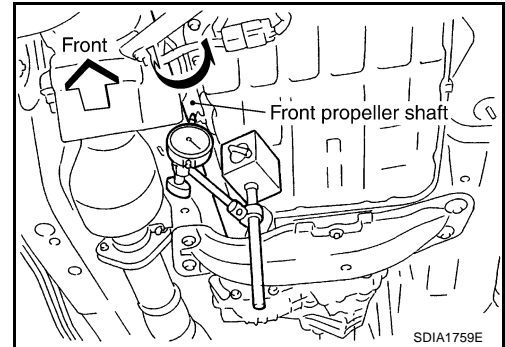

INSPECTION

Inspect the propeller shaft tube for dents or cracks. If damaged, replace the propeller shaft assembly.

Removal and Installation

EDS00103

Model 2F1310

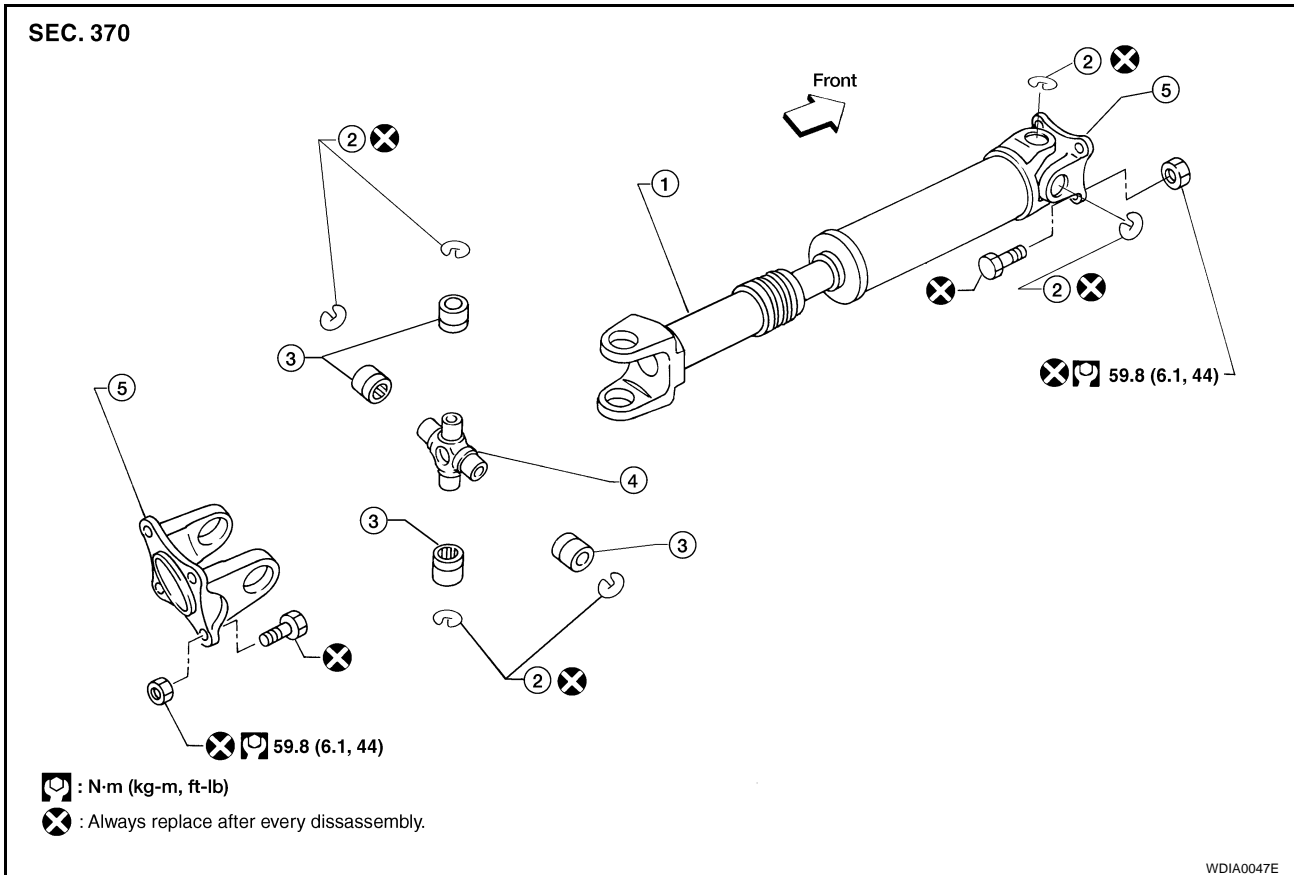

1. Propeller shaft tube

2. Snap ring

3. Journal bearing

4. Journal

5. Flange yoke

FRONT PROPELLER SHAFT

REMOVAL

1. Put matching marks on the front propeller shaft flange yoke and the companion flange of the front final drive as shown.

CAUTION:

For matching marks, use paint. Never damage the flange yoke and companion flange of the front final drive.

2. Remove the bolts and then remove the front propeller shaft from the front final drive and transfer.

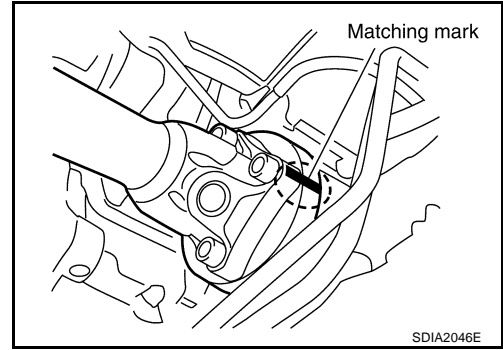

INSPECTION AFTER REMOVAL

- Inspect the propeller shaft tube runout. If run out exceeds the limit, replace the propeller shaft assembly.

Propeller shaft runout limit : 0.6 mm (0.024 in) or less

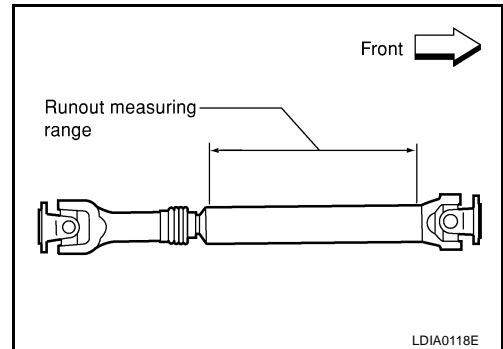

- While holding the flange yoke on one side, check axial play of the journal as shown. If the journal axial play exceeds the specification, replace the propeller shaft assembly.

Journal axial play : 0.02 mm (0.0008 in) or less

- Check the propeller shaft tube for bend and damage. If damage is detected, replace the propeller shaft assembly.

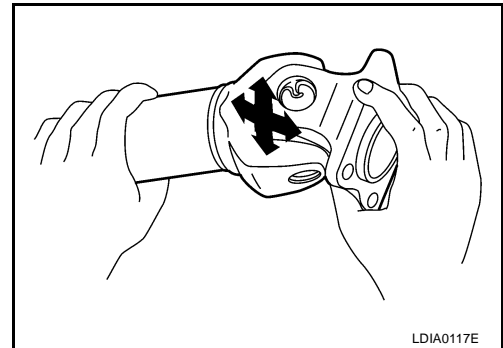

INSTALLATION

Installation is in the reverse order of removal.

- After installation, check for vibration by driving the vehicle. Refer to [PR-3, "NVH Troubleshooting Chart"](#).

CAUTION:

Do not reuse the bolts and nuts. Always install new ones.

Disassembly and Assembly

DISASSEMBLY

EDS00104

Journal

1. Put matching marks on the front propeller shaft tube and flange yoke as shown.

CAUTION:

For matching marks, use paint. Never damage the front propeller shaft or flange yoke.

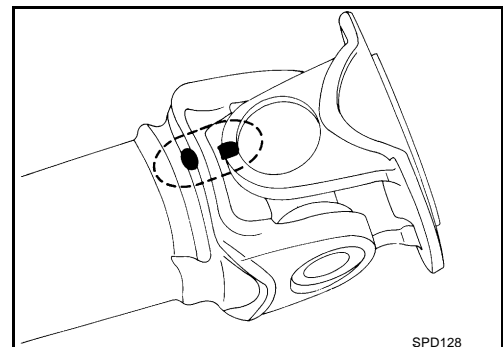

A
B
C
PR
E
F
G
H
I
J
K
L
M

FRONT PROPELLER SHAFT

2. Remove the snap ring.

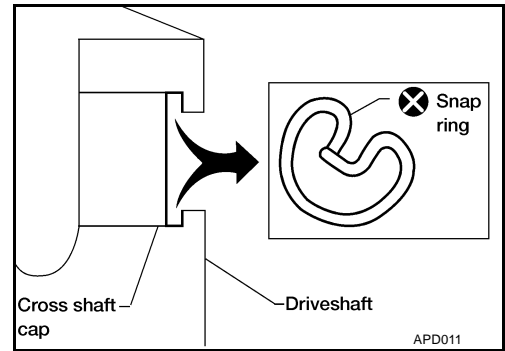

3. Push out and remove the journal bearing by lightly tapping the yoke with a hammer, taking care not to damage the journal or yoke hole.

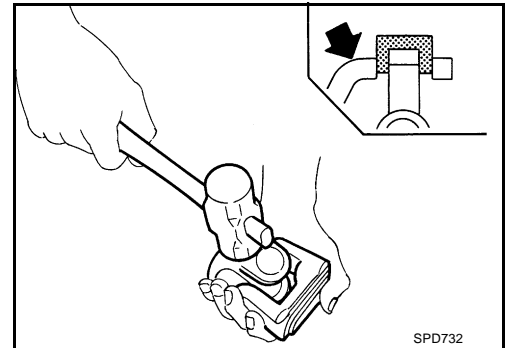

4. Remove the bearing at the opposite side in above operation.

NOTE:

Put marks on the disassembled parts so that they can be reinstalled in their original positions from which they were removed.

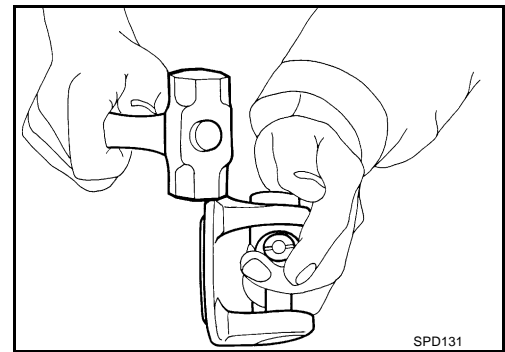

ASSEMBLY

Journal

1. Assemble the journal bearings. Apply multipurpose grease on the bearing inner surface.

NOTE:

During assembly, use caution so that the needle bearings do not fall down.

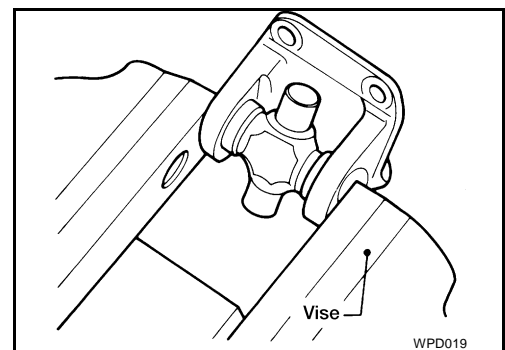

FRONT PROPELLER SHAFT

2. Select snap rings that will provide the specified play in an axial direction of the journal, and install them. Refer to [PR-15. "Snap Ring"](#) .

NOTE:

Select snap rings with a difference in thickness at both sides within 0.02 mm (0.0008 in).

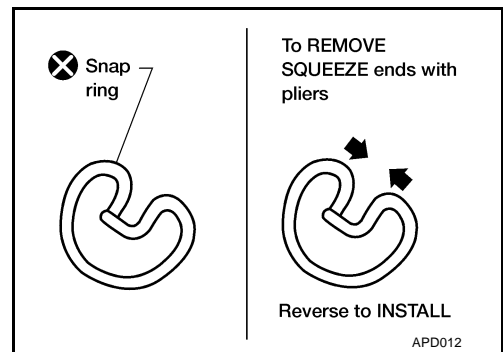

3. Adjust the thrust clearance between the bearing and snap ring to zero by tapping the yoke.

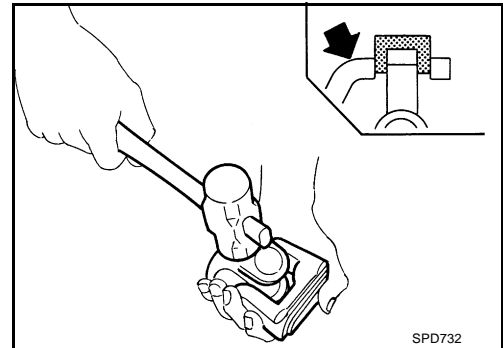

4. Make sure that the journal moves smoothly and is below the propeller shaft joint flex effort specification.

Propeller shaft joint flex effort : 1.96 N-m (0.20 kg-m, 17 in-lb) or less

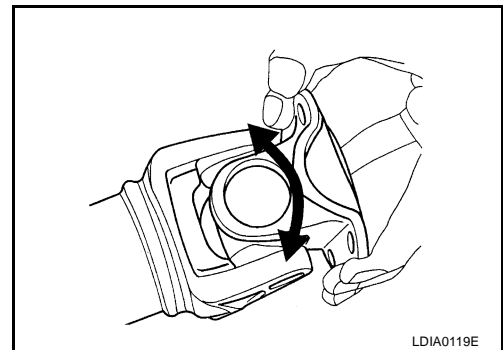

A
B
C
PR
E
F
G
H
I
J
K
L
M

REAR PROPELLER SHAFT

PFP:37000

EDS00105

REAR PROPELLER SHAFT

On-Vehicle Service PROPELLER SHAFT VIBRATION

NOTE:

If vibration is present at high speed, check propeller shaft runout first, then check mounting between propeller shaft and companion flange.

1. Measure the runout of the propeller shaft tube at several points by rotating the final drive companion flange with your hands.

Propeller shaft runout limit : 1.02 mm (0.0402 in) or less

2. If the runout still exceeds specifications, disconnect the propeller shaft at the final drive companion flange; then rotate the companion flange 90°, 180°, 270° degrees and reconnect propeller shaft.
3. Check the runout again. If the runout still exceeds specifications, replace the propeller shaft assembly.
4. After installation, check for vibration by driving vehicle.

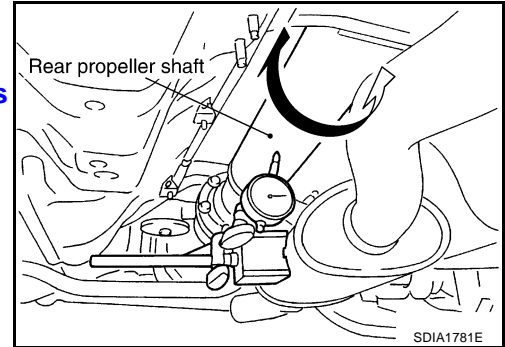

INSPECTION

Inspect the propeller shaft tube for dents or cracks. If damaged, replace the propeller shaft assembly.

Removal and Installation

EDS00106

Model 2S1350

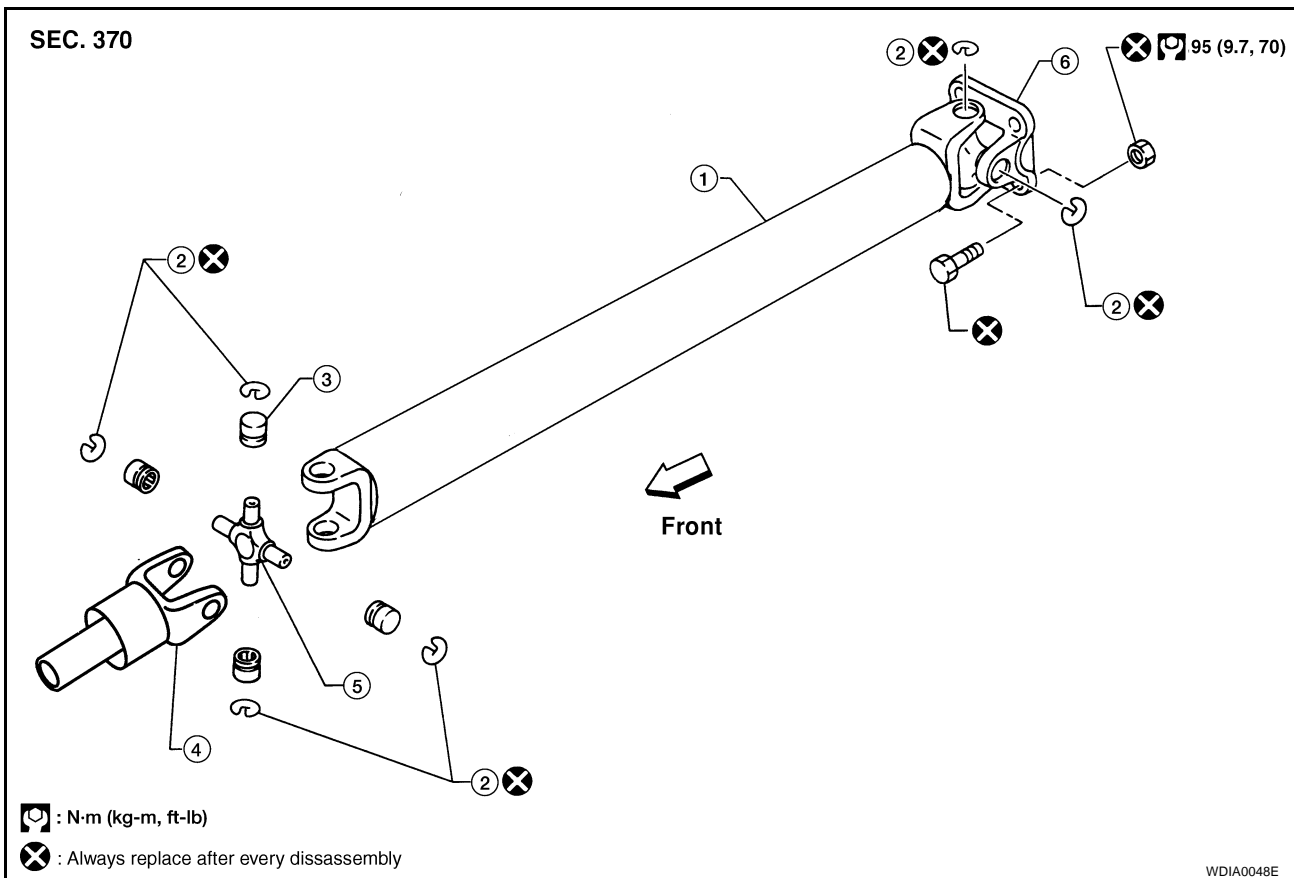

- | | | |
|-------------------------|--------------|--------------------|
| 1. Propeller shaft tube | 2. Snap ring | 3. Journal bearing |
| 4. Sleeve yoke | 5. Journal | 6. Flange yoke |

REAR PROPELLER SHAFT

Model 3S1350

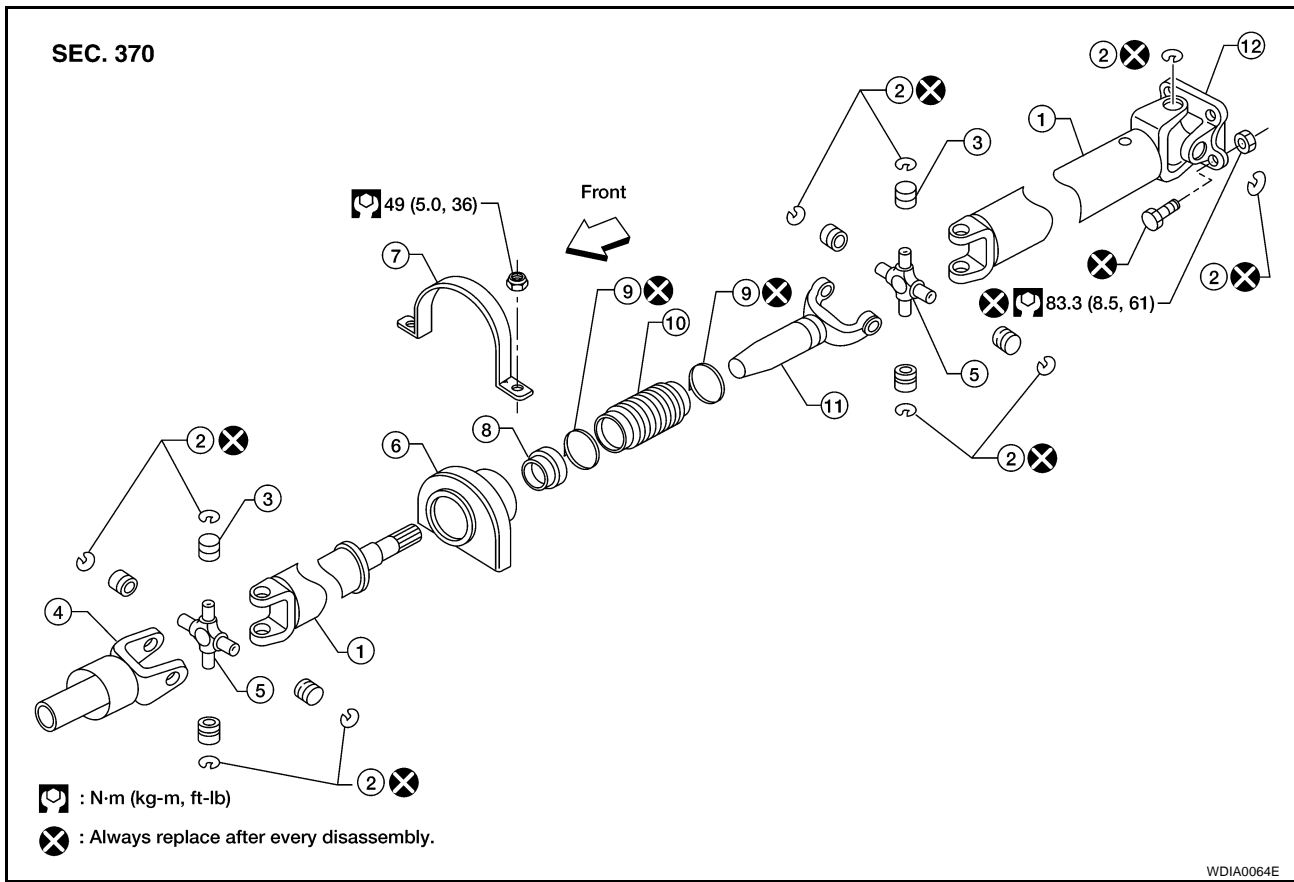

- | | | |
|-----------------------------------|----------------|---------------------------|
| 1. Propeller shaft tube | 2. Snap ring | 3. Journal bearing |
| 4. Sleeve yoke | 5. Journal | 6. Center support bearing |
| 7. Center support bearing bracket | 8. Dust shield | 9. Clamp |
| 10. Boot | 11. Slip yoke | 12. Flange yoke |

REMOVAL

1. Move the A/T select lever to the N position and release the parking brake.
2. Put matching marks on the rear propeller shaft flange yoke and the companion flange of the rear final drive as shown.

CAUTION:

For matching marks, use paint. Never damage the rear propeller shaft flange yoke or the companion flange.

3. Remove the bolts, then remove the propeller shaft from the rear final drive.

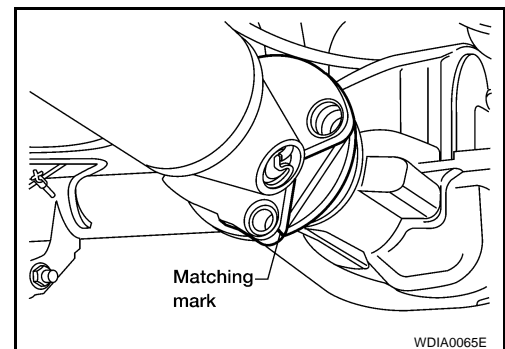

REAR PROPELLER SHAFT

- For model 3S1350, remove the center support bearing bracket nuts, and remove the propeller shaft from the rear final drive.

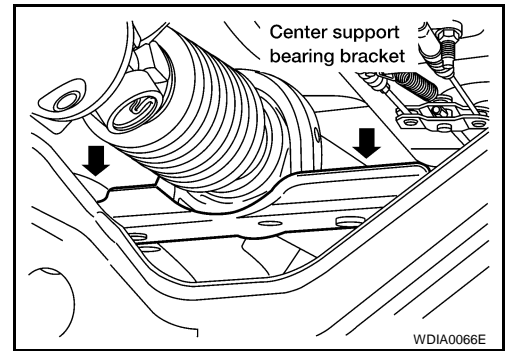

INSPECTION AFTER REMOVAL

- Inspect the propeller shaft runout. If runout exceeds the limit, replace the propeller shaft assembly.

Propeller shaft runout limit : 1.02 mm (0.0402 in) or less

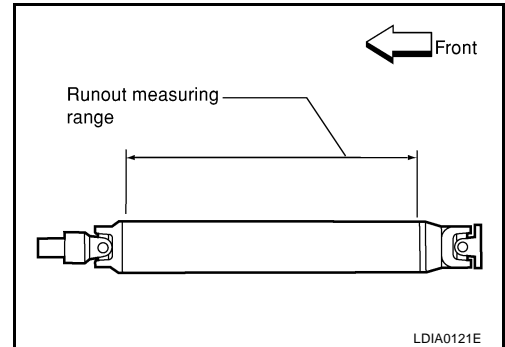

- While holding the flange yoke on one side, check axial play of the journal as shown. If the journal axial play exceeds the specification, replace the propeller shaft assembly.

Journal axial play : 0.02 mm (0.0008 in) or less

- Check the propeller shaft tube for bend and damage. If damage is detected, replace the propeller shaft assembly.

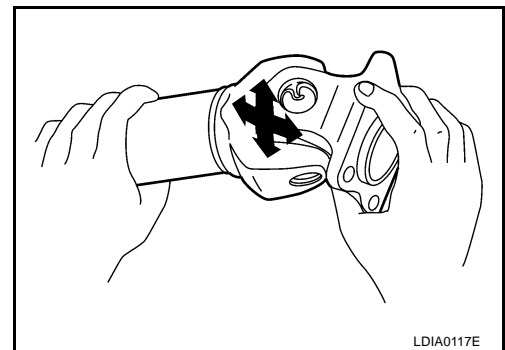

INSTALLATION

Installation is in the reverse order of removal.

- After installation, check for vibration by driving the vehicle. Refer to [PR-3, "NVH Troubleshooting Chart"](#).

CAUTION:

Do not reuse the bolts and nuts. Always install new ones.

REAR PROPELLER SHAFT

EDS00107

Disassembly and Assembly DISASSEMBLY

Journal

1. Remove the propeller shaft assembly from the vehicle. Refer to [PR-8, "Removal and Installation"](#).
2. Put matching marks on the rear propeller shaft tube and flange yoke as shown.

CAUTION:

For matching marks use paint. Never damage the rear propeller shaft or flange yoke.

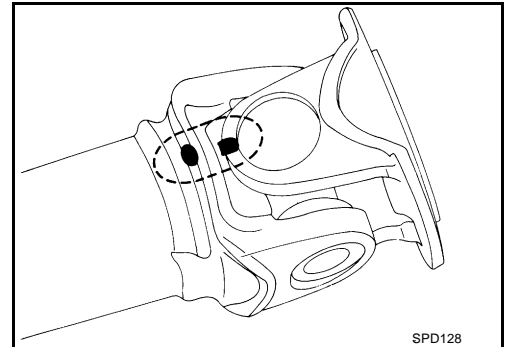

3. Remove the snap rings.

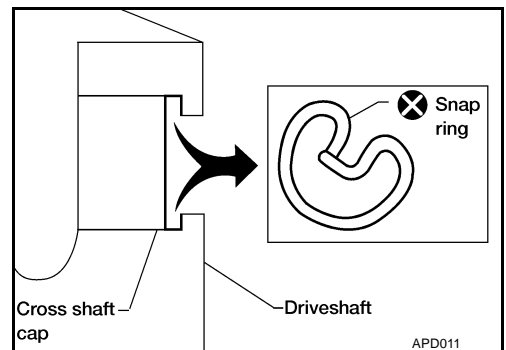

4. Push out and remove the journal bearing by lightly tapping the yoke with a hammer, taking care not to damage the journal or yoke hole.

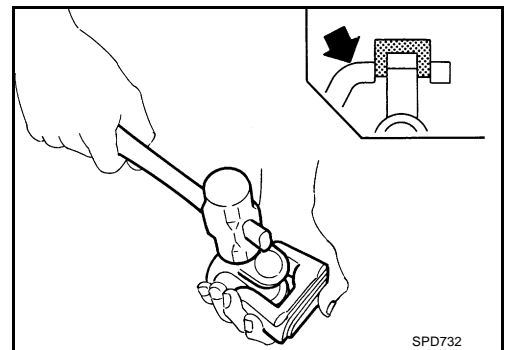

5. Remove the bearing at the opposite side of above operation.

NOTE:

Put marks on the disassembled parts so that they can be reinstalled in their original positions from which they were removed.

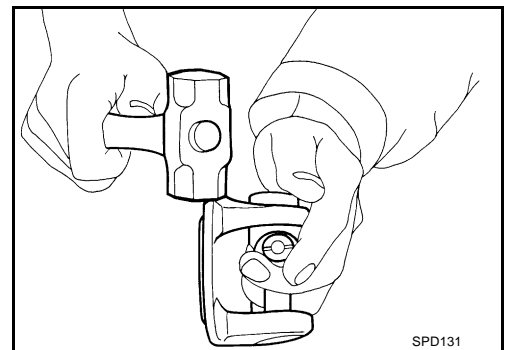

Center Support Bearing

1. Remove the propeller shaft assembly from the vehicle. Refer to [PR-8, "Removal and Installation"](#).

A
B
C
PR
E
F
G
H
I
J
K
L
M

REAR PROPELLER SHAFT

- Put matching marks on the propeller shaft tube and the slip yoke as shown.

CAUTION:

For matching marks, use paint. Never damage the propeller shaft tube or slip yoke.

- Remove and discard the clamp near the center support bearing, then slide the slip yoke off of propeller shaft tube.

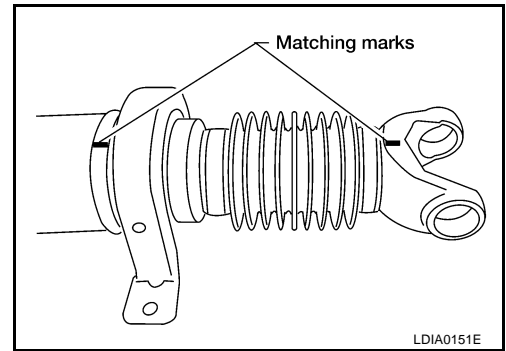

- Lift the dust shield off of the center support bearing.
- Press the center support bearing off the propeller shaft tube using Tool and suitable hydraulic press.

Tool number : 205-D002

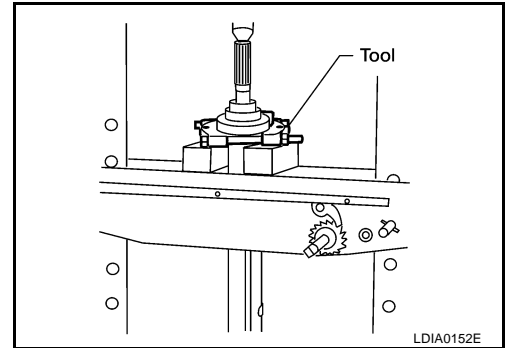

ASSEMBLY

Journal

- Assemble the journal bearings. Apply multipurpose grease on the bearing inner surface.

NOTE:

During assembly, use caution so that the needle bearings do not fall down.

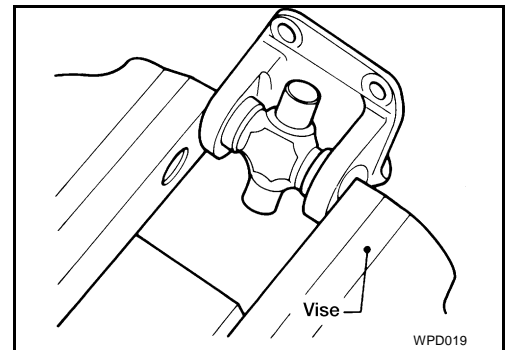

- Select snap rings that will provide the specified play in an axial direction of the journal, and install them. Refer to [PR-15, "Snap Ring"](#).

NOTE:

Select snap rings with a difference in thickness at both sides within 0.02 mm (0.0008 in).

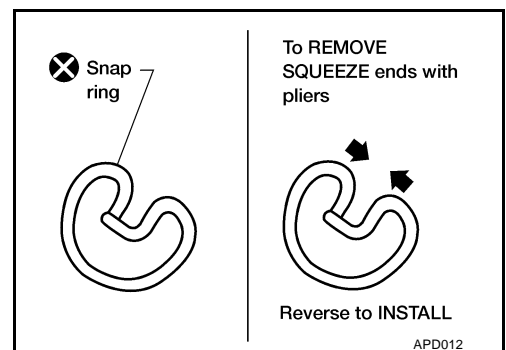

REAR PROPELLER SHAFT

- Adjust the thrust clearance between the bearing and snap ring to zero by tapping the yoke.

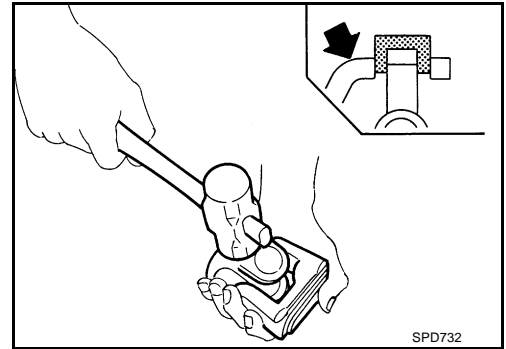

- Make sure that the journal moves smoothly and is below the joint flex effort specification.

Propeller shaft joint flex effort : 2.26 N-m (0.23 kg-m, 20 in-lb) or less

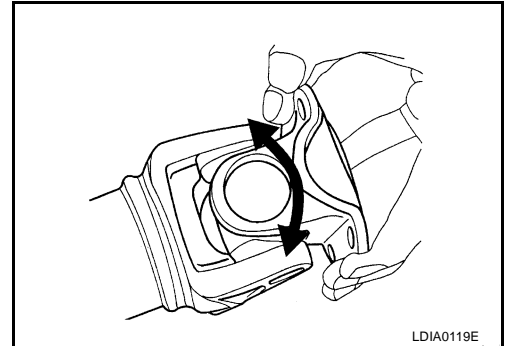

Center Support Bearing

- Apply a thin coat of multi-purpose grease to both the propeller shaft tube and the inside surface of the center support bearing.
- Install the center support bearing on the propeller shaft tube using a suitable pipe pressing on the inner race.

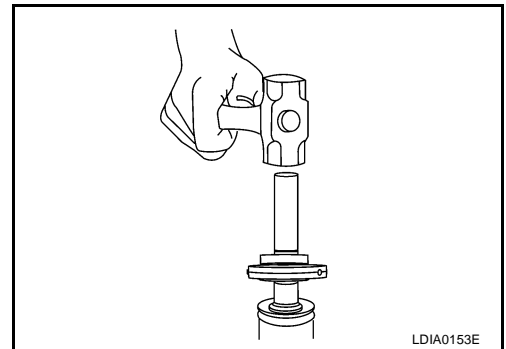

- Install the dust shield.
- Install a new clamp over the boot on the slip yoke.
- Align the matching marks and install the slip yoke on the propeller shaft tube.

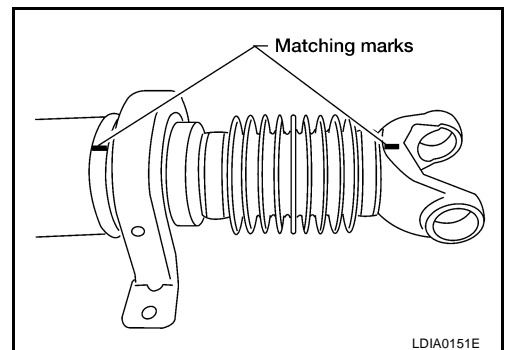

- Clean the surfaces and position the boot over the propeller shaft tube and tighten the clamp.

A
B
C
PR
E
F
G
H
I
J
K
L
M

REAR PROPELLER SHAFT

7. Install the center support bearing bracket, then install the rear propeller shaft assembly in the vehicle. Refer to [PR-8, "Removal and Installation"](#).

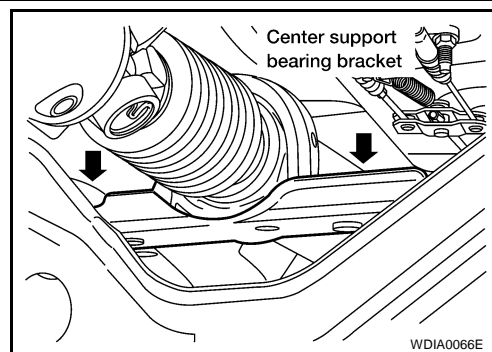

SERVICE DATA AND SPECIFICATIONS (SDS)

SERVICE DATA AND SPECIFICATIONS (SDS)

PF0:00030

General Specifications 4X2 Model

EDS00108

Applied model	VK56DE	
Body	King cab	Crew cab
Propeller shaft model	2S1350	3S1350
Number of joints	2	3
Coupling method with rear final drive	Flange type	Flange type
Coupling method with transmission	Sleeve type	Sleeve type
Shaft length (Spider to spider)	1619 mm (63.74 in)	869 mm (34.21in) (front shaft)
		1209 mm (47.60 in) (rear shaft)
Shaft outer diameter	127.6 mm (5.02 in)	88.9 mm (3.50 in)
Journal axial play	0.02 mm (0.0008 in) or less	
Propeller shaft runout limit	1.02 mm (0.0402 in) or less	0.6 mm (0.24 in) or less
Propeller shaft joint flex effort	2.26 N-m (0.23 kg-m, 20 in-lb) or less	

4X4 Model

Applied model	VK56DE	
Propeller shaft model	Front	Rear
	2F1310	2S1350
Number of joints	2	
Coupling method with front final drive	Flange type	
Coupling method with transfer	Flange type	Sleeve type
Shaft length (Spider to spider)	718 mm (28.27 in)	1619 mm (63.74 in)
Shaft outer diameter	63.5 mm (2.5 in)	127.6 mm (5.02 in)
Journal axial play	0.02 mm (0.0008 in) or less	
Propeller shaft runout limit	0.6 mm (0.024 in) or less	1.02 mm (0.0402 in) or less
Propeller shaft joint flex effort	1.96 N-m (0.20 kg-m, 17 in-lb) or less	2.26 N-m (0.23 kg-m, 20 in-lb) or less

Snap Ring Model 2F1310

EDS00109

Unit: mm (in)

Thickness	Color	Part Number*
1.99 (0.0783)	White	37146-C9400
2.02 (0.0795)	Yellow	37147-C9400
2.05 (0.0807)	Red	37148-C9400
2.08 (0.0819)	Green	37149-C9400
2.11 (0.0831)	Blue	37150-C9400
2.14 (0.0843)	Light brown	37151-C9400
2.17 (0.0854)	Black	37152-C9400
2.20 (0.0866)	No paint	37153-C9400

*Always check with the Parts Department for the latest parts information.

SERVICE DATA AND SPECIFICATIONS (SDS)

Model 2S1350 / 3S1350

Unit: mm (in)

Thickness	Color	Part Number*
1.600 - 1.638 (0.0630 - 0.0645)	Black	37146-7S000
1.549 - 1.588 (0.0610 - 0.0625)	Black	37147-7S000
1.524 - 1.562 (0.0600 - 0.0615)	Black	37148-7S000
1.499 - 1.537 (0.0590 - 0.0605)	Black	37149-7S000

*Always check with the Parts Department for the latest parts information.