

SECTION RFD

REAR FINAL DRIVE

A
B
C
RFD

CONTENTS

WITHOUT ELECTRONIC LOCKING DIFFERENTIAL

PRECAUTIONS	3
Service Notice or Precautions	3
Precautions for Liquid Gasket	3
REMOVAL OF LIQUID GASKET SEALING	3
LIQUID GASKET APPLICATION PROCEDURE.....	3
PREPARATION	5
Special Service Tools	5
Commercial Service Tools	8
NOISE, VIBRATION, AND HARSHNESS (NVH)	
TROUBLESHOOTING	9
NVH Troubleshooting Chart	9
DESCRIPTION	10
Cross-Sectional View	10
DIFFERENTIAL GEAR OIL	11
Checking Final Drive Oil	11
OIL LEAKAGE AND OIL LEVEL	11
Changing Final Drive Oil	11
DRAINING	11
FILLING	11
FRONT OIL SEAL	12
Removal and Installation	12
REMOVAL	12
INSTALLATION	13
CARRIER COVER	14
Removal and Installation	14
REMOVAL	14
INSTALLATION	14
REAR FINAL DRIVE ASSEMBLY	15
Removal and Installation	15
REMOVAL	15

INSTALLATION	15
Disassembly and Assembly	16
COMPONENTS	16
ASSEMBLY INSPECTION AND ADJUSTMENT..	17
DISASSEMBLY	20
INSPECTION AFTER DISASSEMBLY	24
SELECTION ADJUSTING WASHERS	25
ASSEMBLY	28
SERVICE DATA AND SPECIFICATIONS (SDS)	34
General Specifications	34
Inspection and Adjustment	34
DIFFERENTIAL SIDE GEAR CLEARANCE	34
PRELOAD TORQUE	34
BACKLASH	34
COMPANION FLANGE RUNOUT	34
SELECTIVE PARTS	35

WITH ELECTRONIC LOCKING DIFFERENTIAL

PRECAUTIONS	36
Precautions for Supplemental Restraint System (SRS) "AIR BAG" and "SEAT BELT PRE-TENSIONER"	36
Precautions	36
Service Notice or Precaution	37
Precautions for Liquid Gasket	37
REMOVAL OF LIQUID GASKET SEALING	37
LIQUID GASKET APPLICATION PROCEDURE..	37
PREPARATION	39
Special Service Tools	39
Commercial Service Tools	42
NOISE, VIBRATION AND HARSHNESS (NVH)	
TROUBLESHOOTING	43
NVH Troubleshooting Chart	43
DIFFERENTIAL GEAR OIL	44
Changing Differential Gear Oil	44
FILLING	44
Checking Differential Gear Oil	44

E
F
G
H
I
J
K
L
M

DIFFERENTIAL LOCK SYSTEM	45	DIAGNOSTIC PROCEDURE	67
Cross-sectional View	45	Differential Lock Solenoid	68
Differential Lock Operation	46	CONSULT-II REFERENCE VALUE IN DATA	
System Description	46	MONITOR MODE	68
DIFFERENTIAL LOCK SOLENOID	46	DIFFERENTIAL LOCK CONTROL UNIT TER-	
DIFFERENTIAL LOCK POSITION SWITCH	46	MINALS AND REFERENCE VALUE	68
DIFFERENTIAL LOCK CONTROL UNIT	46	DIAGNOSTIC PROCEDURE	69
DIFFERENTIAL LOCK MODE SWITCH	46	COMPONENT INSPECTION	72
DIFF LOCK INDICATOR LAMP	46	ABS System	72
System Diagram	47	DIAGNOSTIC PROCEDURE	72
COMPONENTS FUNCTION DESCRIPTION	47	CAN Communication Line	73
CAN Communication	47	DIAGNOSTIC PROCEDURE	73
SYSTEM DESCRIPTION	47	TROUBLE DIAGNOSIS FOR SYMPTOMS	74
TROUBLE DIAGNOSIS	48	DIFF LOCK Indicator Lamp Does Not Turn ON	74
Fail-safe Function	48	DIAGNOSTIC PROCEDURE	74
How to Perform Trouble Diagnosis	48	DIFF LOCK Indicator Lamp Does Not Change	77
BASIC CONCEPT	48	DIAGNOSTIC PROCEDURE	77
Location of Electrical Parts	49	DIFF LOCK Indicator Lamp Sometimes Flashes	78
Wiring Diagram — DIFLOC —	50	DIAGNOSTIC PROCEDURE	78
Trouble Diagnosis Chart for Symptoms	52	DIFFERENTIAL LOCK CONTROL UNIT	80
Differential Lock Control Unit Input/Output Signal		Removal and Installation	80
Reference Values	52	REMOVAL	80
DIFFERENTIAL LOCK CONTROL UNIT		INSTALLATION	80
INSPECTION TABLE	52	DIFFERENTIAL LOCK POSITION SWITCH	81
CONSULT-II Function (DIFF LOCK)	54	Removal and Installation	81
CONSULT-II SETTING PROCEDURE	54	REMOVAL	81
SELF-DIAG RESULTS MODE	55	INSTALLATION	82
DATA MONITOR MODE	57	FRONT OIL SEAL	85
TROUBLE DIAGNOSIS FOR SYSTEM	58	Removal and Installation	85
Power Supply Circuit For Differential Lock Control		REMOVAL	85
Unit	58	INSTALLATION	86
CONSULT-II REFERENCE VALUE IN DATA		CARRIER COVER	87
MONITOR MODE	58	Removal and Installation	87
DIFFERENTIAL LOCK CONTROL UNIT TER-		REMOVAL	87
MINALS AND REFERENCE VALUE	58	INSTALLATION	87
DIAGNOSTIC PROCEDURE	59	REAR FINAL DRIVE ASSEMBLY	88
Differential Lock Control Unit	60	Removal and Installation	88
DIAGNOSTIC PROCEDURE	60	REMOVAL	88
Differential Lock Mode Switch	60	INSTALLATION	89
CONSULT-II REFERENCE VALUE IN DATA		Disassembly and Assembly	89
MONITOR MODE	60	COMPONENTS	89
DIFFERENTIAL LOCK CONTROL UNIT TER-		ASSEMBLY INSPECTION AND ADJUSTMENT...	90
MINALS AND REFERENCE VALUE	60	DISASSEMBLY	93
DIAGNOSTIC PROCEDURE	61	INSPECTION AFTER DISASSEMBLY	97
COMPONENT INSPECTION	63	SELECTION ADJUSTING WASHERS	98
Differential Lock Position Switch	64	ASSEMBLY	100
CONSULT-II REFERENCE VALUE IN DATA		SERVICE DATA AND SPECIFICATIONS (SDS) ...	105
MONITOR MODE	64	General Specifications	105
DIFFERENTIAL CONTROL UNIT TERMINALS		Inspection and Adjustment	105
AND REFERENCE VALUE	64	PRELOAD TORQUE	105
DIAGNOSTIC PROCEDURE	65	BACKLASH	105
Differential Lock Solenoid Relay	67	COMPANION FLANGE RUNOUT	105
CONSULT-II REFERENCE VALUE IN DATA		SELECTIVE PARTS	106
MONITOR MODE	67		

PRECAUTIONS [WITHOUT ELECTRONIC LOCKING DIFFERENTIAL]

PRECAUTIONS

PF0:00001

Service Notice or Precautions

EDS003NE

- Check for the correct installation status prior to removal or disassembly. If matching marks are required, be certain they do not interfere with the function of the parts when applied.
- Overhaul should be done in a clean work area, it is preferable to work in dustproof area.
- Before disassembly, using steam or white gasoline, completely remove sand and mud from the exterior of the unit, preventing them from entering into the unit during disassembly or assembly.
- Check appearance of the disassembled parts for damage, deformation, and unusual wear. Replace them with a new ones if necessary.
- Gaskets, seals and O-rings should be replaced any time when the unit is disassembled.
- In principle, tighten bolts or nuts gradually in several steps working diagonally from inside to outside. If tightening sequence is specified, observe it.
- Clean and flush the parts sufficiently and blow-dry them.
- Be careful not to damage sliding surfaces and mating surfaces.
- When applying sealant, remove the old sealant from the mounting surface; then remove any moisture, oil, and foreign materials from the application and mounting surfaces.
- Always use shop paper for cleaning the inside of components.
- Avoid using cotton gloves or shop rags to prevent entering of lint.
- During assembly, observe the specified tightening torque, and apply new differential gear oil, petroleum jelly, or multi-purpose grease as specified for each vehicle, if necessary.

A

B

C

RFD

E

F

G

Precautions for Liquid Gasket

REMOVAL OF LIQUID GASKET SEALING

EDS003NF

- After removing the bolts and nuts, separate the mating surface and remove the old liquid gasket sealing using Tool.

Tool number : KV10111100 (J-37228)

CAUTION:

Do not damage the mating surfaces.

- Tap the seal cutter to insert it.
- In areas where the Tool is difficult to use, lightly tap to slide it.

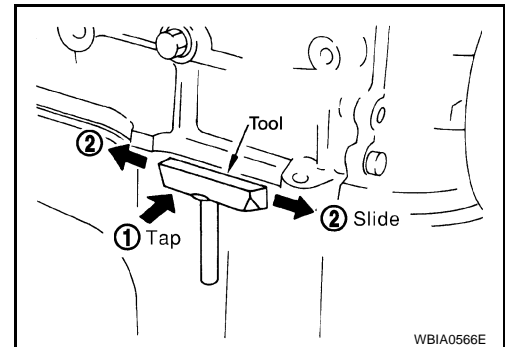

H

I

J

K

LIQUID GASKET APPLICATION PROCEDURE

1. Remove the old liquid gasket adhering to the gasket application surface and the mating surface using suitable tool.
 - Remove the liquid gasket completely from the groove of the liquid gasket application surface, bolts, and bolt holes.
2. Thoroughly clean the mating surfaces and remove adhering moisture, grease and foreign material.

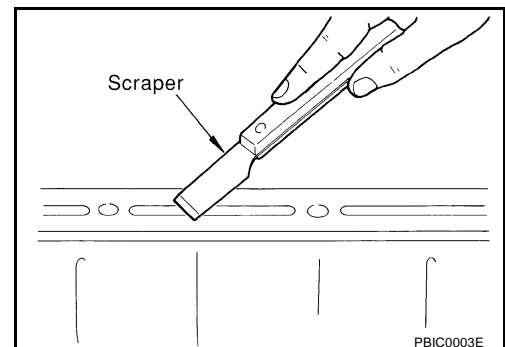

L

M

PRECAUTIONS [WITHOUT ELECTRONIC LOCKING DIFFERENTIAL]

3. Attach the liquid gasket tube to the Tool.

Tool number : WS39930000 (—)

Use Genuine RTV Silicone Sealant or equivalent. Refer to MA-11, "RECOMMENDED FLUIDS AND LUBRICANTS" .

4. Apply the liquid gasket without breaks to the specified location with the specified dimensions.

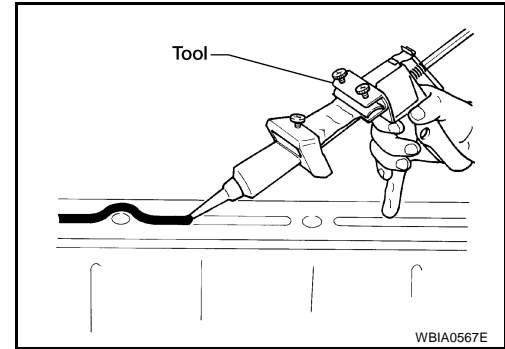

- If there is a groove for the liquid gasket application, apply the liquid gasket to the groove.
- As for the bolt holes, normally apply the liquid gasket inside the holes. If specified in the procedure, it should also be applied outside the holes.
- Within five minutes of liquid gasket application, install the mating component.
- If the liquid gasket protrudes, wipe it off immediately.
- Do not retighten after the installation.
- Wait 30 minutes or more after installation before refilling the engine with engine oil and engine coolant.

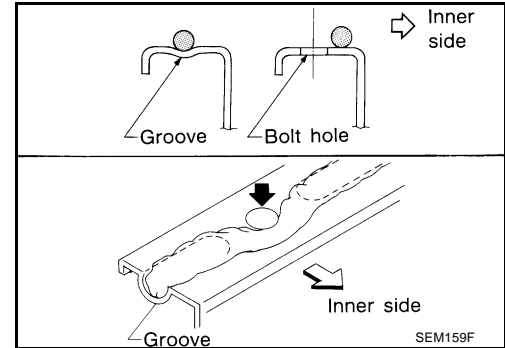

CAUTION:

If there are specific instructions in this manual, observe them.

PREPARATION [WITHOUT ELECTRONIC LOCKING DIFFERENTIAL]

PREPARATION

PF0:00002

Special Service Tools

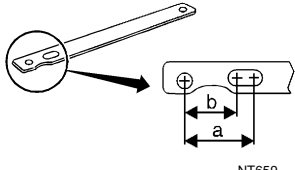
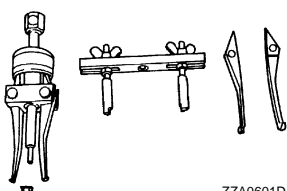
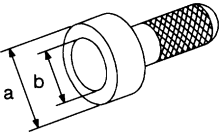
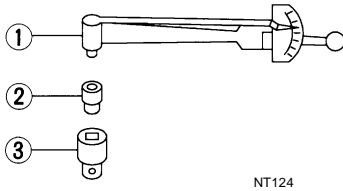
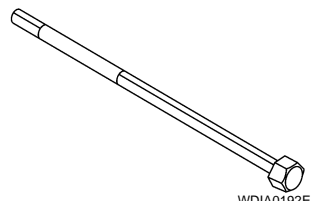
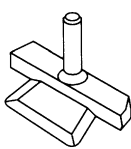

EDS003NG

The actual shapes of Kent-Moore tools may differ from those of special service tools illustrated here.

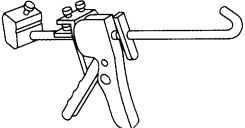
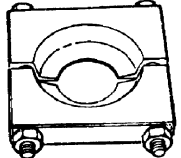
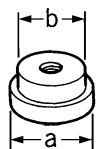
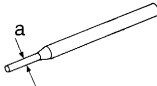
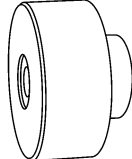
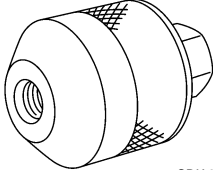

Tool number (Kent-Moore No.) Tool name	Description
KV40104000 (—) Flange wrench <div style="text-align: center;">  <p>NT659</p> </div>	Removing and installing drive pinion nut a: 85 mm (3.35 in) dia. b: 65 mm (2.56 in) dia.
ST33290001 (J-34286) Puller <div style="text-align: center;">  <p>ZZA0601D</p> </div>	Removing front oil seal
ST15310000 (—) Drift <div style="text-align: center;">  <p>NT115</p> </div>	Installing front oil seal a: 96mm (3.77 in) dia. b: 84 mm (3.30 in) dia.
ST3127S000 (J-25765-A) Preload gauge set <ol style="list-style-type: none"> 1. GG91030000 (J-25765) Torque wrench 2. HT62940000 (1/2") (—) Socket adapter 3. HT62900000 (3/8") (—) Socket adapter <div style="text-align: center;">  <p>NT124</p> </div>	Inspecting drive pinion bearing preload and total preload
— (C-4164) Adjuster tool <div style="text-align: center;">  <p>WDIA0192E</p> </div>	Removing and installing side bearing ad- juster
KV10111100 (J-37228) Seal cutter <div style="text-align: center;">  <p>S-NT046</p> </div>	Removing carrier cover

A
B
C
RFD
E
F
G
H
I
J
K
L
M

PREPARATION [WITHOUT ELECTRONIC LOCKING DIFFERENTIAL]

Tool number (Kent-Moore No.) Tool name	Description
WS39930000 (—) Tube presser <div style="text-align: center;">  <small>S-NT052</small> </div>	Pressing the tube of liquid gasket
ST30021000 (J-22912-01) Puller <div style="text-align: center;">  <small>ZZA0700D</small> </div>	Removing drive pinion rear bearing inner race
ST33081000 (—) Adapter <div style="text-align: center;">  <small>ZZA1000D</small> </div>	Removing and installing side bearing inner race a: 43 mm (1.69 in) dia. b: 33.5 mm (1.32 in) dia.
ST23550000 (—) Pin punch <div style="text-align: center;">  <small>NT410</small> </div>	Removing and installing lock pin a: 4.5 mm (0.177 in) dia.
— (8144) Pinion block <div style="text-align: center;">  <small>SDIA2599E</small> </div>	Adjusting pinion gear height
— (6740) Cone <div style="text-align: center;">  <small>SDIA2601E</small> </div>	Adjusting pinion gear height
— (6741) Screw <div style="text-align: center;">  <small>SDIA2602E</small> </div>	Adjusting pinion gear height

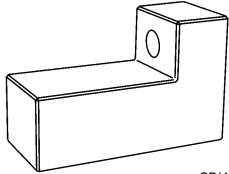
PREPARATION [WITHOUT ELECTRONIC LOCKING DIFFERENTIAL]

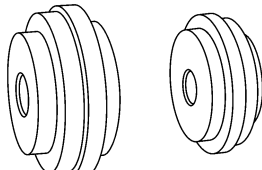
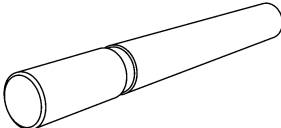
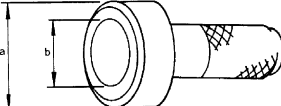
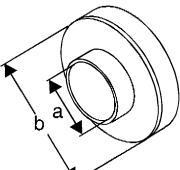
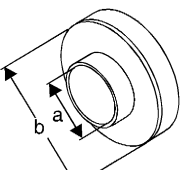
Tool number (Kent-Moore No.) Tool name	Description	
<p>— (6739) Pinion height lock</p>  <p style="text-align: right; font-size: small;">SDIA2603E</p>	Adjusting pinion gear height	A B C
<p>— (D-115-2) Scooter block</p>  <p style="text-align: right; font-size: small;">SDIA2604E</p>	Adjusting pinion gear height	RFD E
<p>— (8541A-1) Arbor disc</p>  <p style="text-align: right; font-size: small;">SDIA2605E</p>	Adjusting pinion gear height	F G H
<p>— (D-115-3) Arbor</p>  <p style="text-align: right; font-size: small;">SDIA2606E</p>	Adjusting pinion gear height	I J
<p>ST01500001 (—) Drift</p>  <p style="text-align: right; font-size: small;">ZZA0811D</p>	Installing drive pinion rear bearing outer race a: 89mm (3.50 in) dia. b: 79 mm (3.11 in) dia.	K L
<p>ST30022000 (—) Drift</p>  <p style="text-align: right; font-size: small;">NT660</p>	Installing drive pinion rear bearing outer race a: 46 mm (1.81 in) dia. b: 110 mm (4.33 in) dia.	M
<p>ST33022000 (—) Drift</p>  <p style="text-align: right; font-size: small;">NT660</p>	Installing drive pinion front bearing outer race a: 49 mm (1.92 in) dia. b: 67 mm (2.63 in) dia.	

PREPARATION [WITHOUT ELECTRONIC LOCKING DIFFERENTIAL]

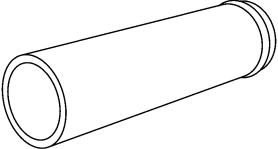
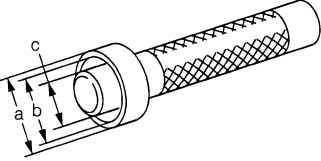
Tool number (Kent-Moore No.) Tool name	Description
<p style="text-align: center;">— (C-4040) Installer</p>  <p style="text-align: right; margin-right: 50px;">SDIA2607E</p>	<p>Installing drive pinion rear bearing inner race</p>
<p>KV38100300 (J-25523) Drift</p>  <p style="text-align: right; margin-right: 50px;">ZZA1046D</p>	<p>Installing side bearing inner race a: 54 mm (2.13 in) dia. b: 46 mm (1.81 in) dia. c: 32mm (1.26 in) dia.</p>

Commercial Service Tools

EDS003NH

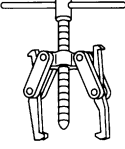
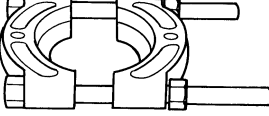
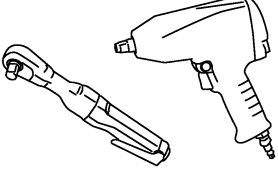
Tool name	Description
<p>Puller</p>  <p style="text-align: right; margin-right: 50px;">NT077</p>	<p>Removing companion flange and side bearing inner race</p>
<p>Puller</p>  <p style="text-align: right; margin-right: 50px;">ZZB0823D</p>	<p>Removing side bearing inner race</p>
<p>Power tool</p>  <p style="text-align: right; margin-right: 50px;">PBIC0190E</p>	<p>Loosening bolts and nuts</p>

DESCRIPTION
[WITHOUT ELECTRONIC LOCKING DIFFERENTIAL]

DESCRIPTION

PFP:00000

Cross-Sectional View

EDS003NJ

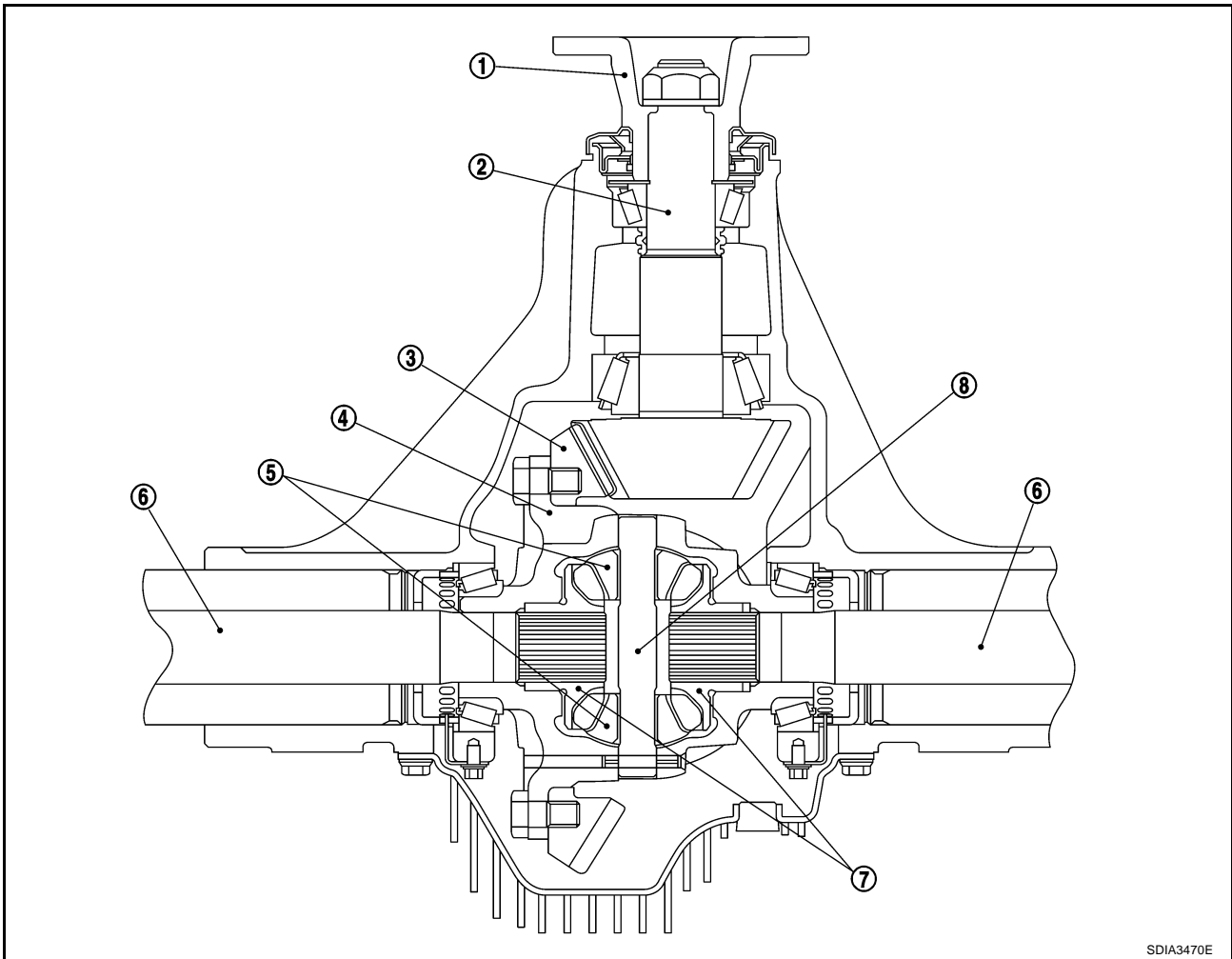

SDIA3470E

- | | | |
|----------------------|----------------------|---------------|
| 1. Companion flange | 2. Drive pinion | 3. Drive gear |
| 4. Differential case | 5. Pinion mate gear | 6. Axle shaft |
| 7. Side gear | 8. Pinion mate shaft | |

DIFFERENTIAL GEAR OIL [WITHOUT ELECTRONIC LOCKING DIFFERENTIAL]

DIFFERENTIAL GEAR OIL

PF0:KLD30

Checking Final Drive Oil

EDS003NK

NOTE:

Rear final drive shown, front final drive similar.

OIL LEAKAGE AND OIL LEVEL

1. Check that gear oil is not leaking from the final drive assembly or around it.
2. Check the gear oil level from filler plug mounting hole as shown.

CAUTION:

Do not start engine while checking oil level.

3. Apply sealant to the filler plug. Install the filler plug on the final drive assembly and tighten to specification.

- Use Genuine Silicone RTV or equivalent. Refer to [GI-45, "Recommended Chemical Products and Sealants"](#).

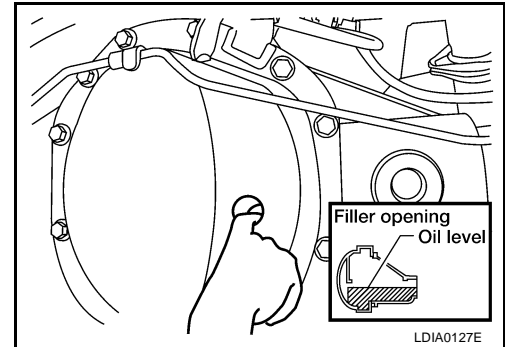

Oil grade and viscosity : Refer to [MA-11, "Fluids and Lubricants"](#).

Filler plug : Refer to [RFD-16, "COMPONENTS" \(FFD\)](#), [RFD-15, "Removal and Installation" \(RFD without ELD\)](#), [RFD-88, "Removal and Installation" \(RFD with ELD\)](#).

Changing Final Drive Oil

EDS003NL

NOTE:

Rear final drive shown, front final drive similar.

DRAINING

1. Stop the engine.
 2. Remove the drain plug and drain the gear oil.
 3. Apply sealant to the drain plug. Install the drain plug on the final drive assembly and tighten to specification.
- Use Genuine Silicone RTV or equivalent. Refer to [GI-45, "Recommended Chemical Products and Sealants"](#).

Filler plug : Refer to [RFD-16, "COMPONENTS" \(FFD\)](#), [RFD-15, "Removal and Installation" \(RFD without ELD\)](#), [RFD-88, "Removal and Installation" \(RFD with ELD\)](#).

FILLING

1. Remove the filler plug. Fill with new specified gear oil until the gear oil level reaches the specified limit near the filler plug mounting hole as shown.

Oil grade and capacity : Refer to [MA-11, "Fluids and Lubricants"](#).

2. After refilling the gear oil, check the gear oil level as shown. Apply sealant to the filler plug. Install the filler plug on the final drive assembly and tighten to specification.

- Use Genuine Silicone RTV or equivalent. Refer to [GI-45, "Recommended Chemical Products and Sealants"](#).

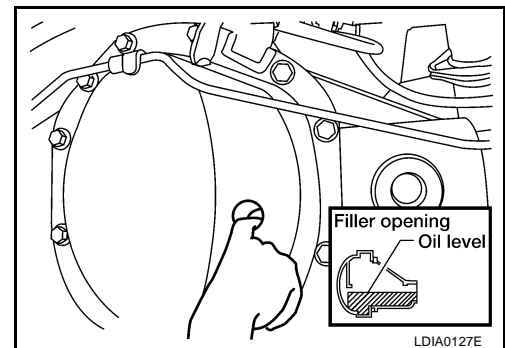

Filler plug : Refer to [RFD-16, "COMPONENTS" \(FFD\)](#), [RFD-15, "Removal and Installation" \(RFD without ELD\)](#), [RFD-88, "Removal and Installation" \(RFD with ELD\)](#).

FRONT OIL SEAL [WITHOUT ELECTRONIC LOCKING DIFFERENTIAL]

FRONT OIL SEAL

PFP:38189

Removal and Installation REMOVAL

EDS003NM

1. Remove rear propeller shaft. Refer to [PR-8, "Removal and Installation"](#) .
2. Remove wheel and tire assemblies.
3. Remove brake calipers and rotors. Refer to [BR-30, "Removal and Installation of Brake Caliper and Disc Rotor"](#) .
4. Using an inch-pound, torque wrench, rotate the pinion three or four times.
5. Record the rotating torque.
6. Loosen drive pinion nut while holding companion flange using Tool.

Tool number : KV40104000 (—)

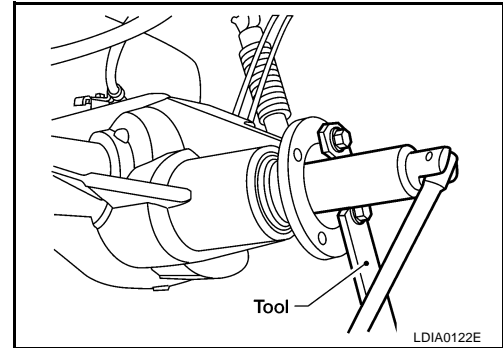

7. Put matching mark on the thread edge of drive pinion. The mark should be in line with the mark on companion flange.

CAUTION:

For matching mark, use paint. Do not damage drive pinion.

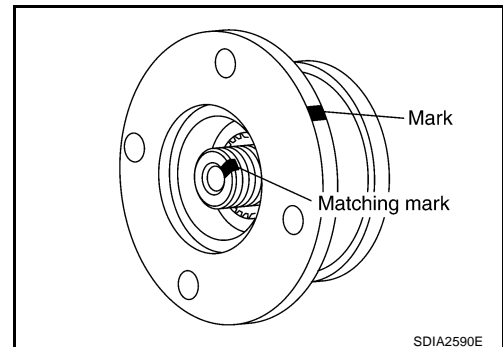

8. Remove companion flange using a suitable tool.

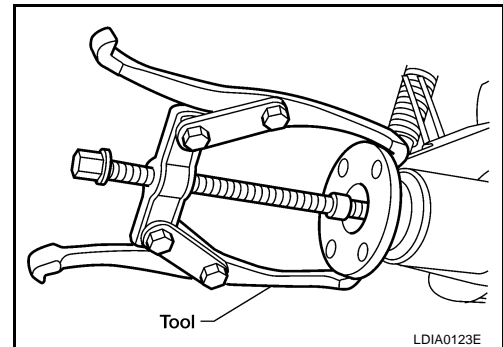

9. Remove front oil seal using Tool.

Tool number : ST33290001 (J-34286)

CAUTION:

Be careful not to damage axle housing.

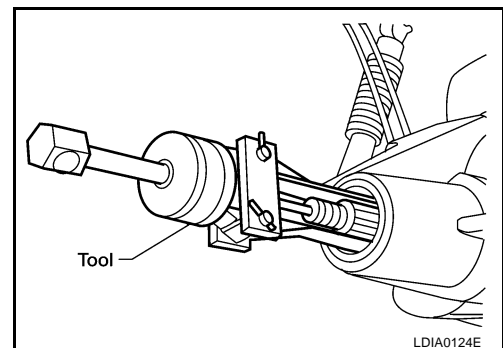

FRONT OIL SEAL [WITHOUT ELECTRONIC LOCKING DIFFERENTIAL]

INSTALLATION

1. Apply multi-purpose grease to new oil seal lips. Install new front oil seal into axle housing using Tool.

Tool number : ST15310000 (—)

CAUTION:

- Do not reuse oil seal.
- When installing, do not incline oil seal.

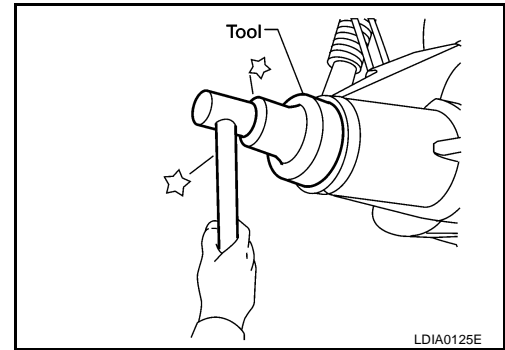

2. Align the matching mark of drive pinion with the mark of companion flange, then install companion flange.

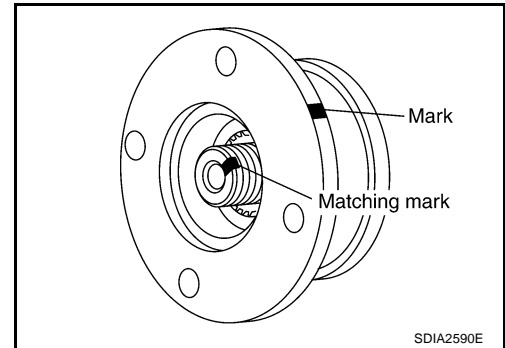

3. Assemble washer if required and new drive pinion nut on pinion gear and tighten nut until there is zero bearing end play.

CAUTION:

Do not reuse drive pinion nut and washer.

4. Rotate drive pinion using an inch-pound torque wrench and flange wrench. Rotating torque should be equal to the reading recorded in step 5 above during removal plus an additional 0.56 N·m (5 in-lb).

Tool number : KV40104000 (—)

5. If the rotating torque is low, continue to tighten drive pinion nut in 6.8 N·m (5 ft-lb) increments until proper rotating torque is achieved. Refer to [RFD-16, "COMPONENTS"](#).

CAUTION:

Do not loosen drive pinion nut to decrease drive pinion rear bearing rotating torque and do not exceed specified preload torque. If preload torque or rotating torque is exceeded a new collapsible spacer must be installed. If the minimum tightening torque is reached prior to reaching the required rotating torque, collapsible spacer may have been damaged. Replace collapsible spacer.

6. Install rear propeller shaft. Refer to [PR-8, "Removal and Installation"](#).
7. Check gear lubricant level and fill with proper lubricant if required. Refer to [RFD-11, "Checking Final Drive Oil"](#).
8. Install brake rotors, calipers, wheel and tire assemblies. Refer to [BR-30, "Removal and Installation of Brake Caliper and Disc Rotor"](#).

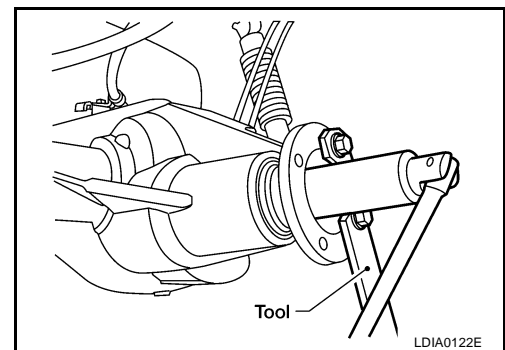

CARRIER COVER [WITHOUT ELECTRONIC LOCKING DIFFERENTIAL]

PF3:38351

CARRIER COVER

Removal and Installation REMOVAL

EDS003NN

1. Drain gear oil. Refer to [RFD-11, "DRAINING"](#) .
2. Remove carrier cover.
 - Disconnect parking brake cable from carrier cover.
 - Disconnect brake tube from carrier cover.

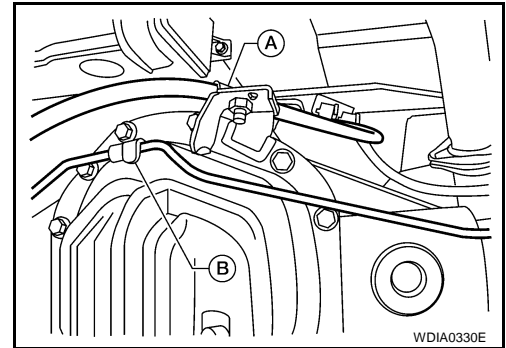

INSTALLATION

1. Apply sealant to mating surface of carrier cover.
 - Use Genuine Silicone RTV or equivalent. Refer to [GI-45, "Recommended Chemical Products and Sealants"](#) .

CAUTION:
Remove old sealant adhering to mounting surfaces. Also remove any moisture, oil, or foreign material adhering to application and mounting surfaces.
2. Install carrier cover on axle housing and tighten carrier cover bolts to the specified torque. Refer to [RFD-16, "COMPONENTS"](#) .
3. Connect parking brake cable and brake tube to carrier cover.
4. Fill with new gear oil until oil level reaches the specified limit near filler plug mounting hole. Refer to [RFD-11, "Checking Final Drive Oil"](#) .

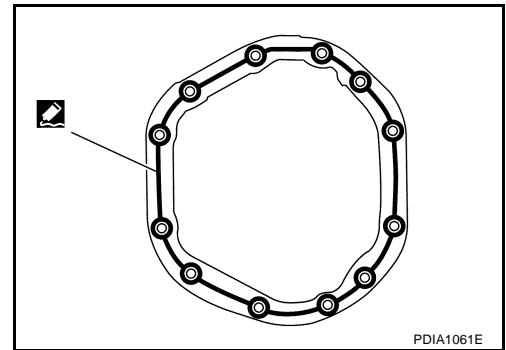

REAR FINAL DRIVE ASSEMBLY

[WITHOUT ELECTRONIC LOCKING DIFFERENTIAL]

REAR FINAL DRIVE ASSEMBLY

PF3:38300

Removal and Installation

EDS003NO

REMOVAL

CAUTION:

- Be careful not to damage spline, companion flange and front oil seal when removing propeller shaft.
 - Before removing final drive assembly or rear axle assembly, disconnect ABS sensor harness connector from the assembly and move it away from final drive/rear axle assembly area. Failure to do so may result in sensor wires being damaged and sensor becoming inoperative.
1. Drain rear final drive gear oil. Refer to [RFD-11, "DRAINING"](#) .
 2. Remove rear propeller shaft. Refer to [PR-8, "Removal and Installation"](#) .
 - Plug rear end of transfer.
 3. Remove axle shaft. Refer to [RAX-6, "Removal and Installation"](#) .
 4. Support rear final drive using a suitable jack.
 5. Disconnect the following components from rear final drive.
 - Brake tube block connectors. Refer to [BR-13, "Removal and Installation of Rear Brake Piping and Brake Hose"](#) .
 - ABS sensor wire harness. Refer to [BRC-38, "Removal and Installation"](#) (without VDC), [BRC-149, "Removal and Installation"](#) (with VDC).
 - Parking brake cable.
 - Brake tube.
 6. Disconnect brake hose from brake tube at the mounting clip on top of axle housing. Then remove the metal clip to disconnect brake line from the mounting clip on top of axle housing.
 7. Remove rear shock absorber lower bolts. Refer to [RSU-7, "Removal and Installation"](#) .
 8. Remove leaf spring U-bolt nuts. Refer to [RSU-8, "Removal and Installation"](#) .
 9. Remove rear final drive assembly.

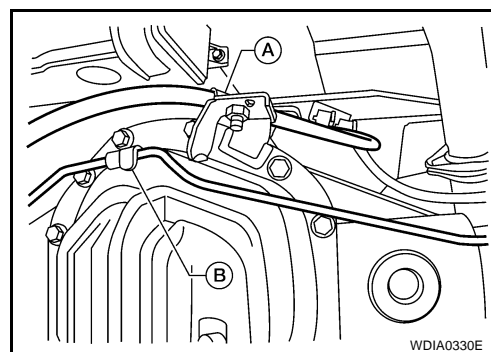

INSTALLATION

Note the following, and installation is in the reverse order of removal.

- Fill with new gear oil until oil level reaches the specified limit near filler plug mounting hole. Refer to [RFD-11, "Checking Final Drive Oil"](#) .
- Bleed the air from brake system. Refer to [BR-11, "Bleeding Brake System"](#) .

REAR FINAL DRIVE ASSEMBLY [WITHOUT ELECTRONIC LOCKING DIFFERENTIAL]

EDS003NP

Disassembly and Assembly COMPONENTS

SEC. 380

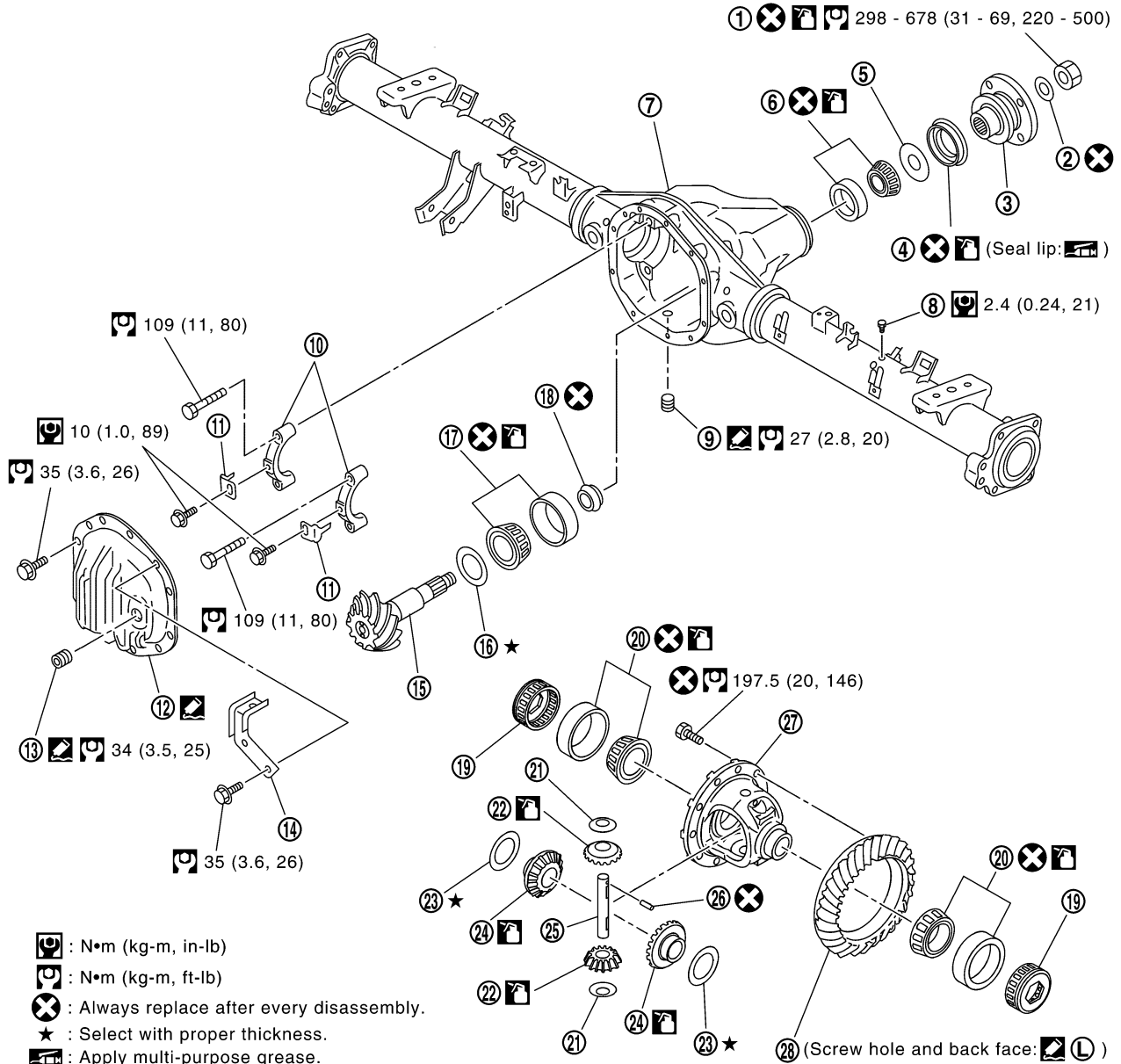

🛢️ : N•m (kg-m, in-lb)

🛢️ : N•m (kg-m, ft-lb)

⊗ : Always replace after every disassembly.

★ : Select with proper thickness.

🛢️ : Apply multi-purpose grease.

🛢️ : Apply gear oil.

🛢️ : Apply Genuine Liquid Gasket, Three Bond TB1215 or equivalent.

🛢️ (L) : Apply Genuine High Strength Thread Locking Sealant, Loctite 648 or equivalent.

SDIA3471E

- | | | |
|--|--------------------------------|-------------------------------|
| 1. Drive pinion nut | 2. Drive pinion nut washer | 3. Companion flange |
| 4. Front oil seal | 5. Front bearing thrust washer | 6. Drive pinion front bearing |
| 7. Axle housing | 8. Breather | 9. Drain plug |
| 10. Side bearing cap | 11. Adjuster lock plate | 12. Carrier cover |
| 13. Filler plug | 14. Bracket | 15. Drive pinion |
| 16. Drive pinion height adjusting washer | 17. Drive pinion rear bearing | 18. Collapsible spacer |
| 19. Side bearing adjuster | 20. Side bearing | 21. Pinion mate thrust washer |
| 22. Pinion mate gear | 23. Side gear thrust washer | 24. Side gear |
| 25. Pinion mate shaft | 26. Lock pin | 27. Differential case |
| 28. Drive gear | | |

REAR FINAL DRIVE ASSEMBLY [WITHOUT ELECTRONIC LOCKING DIFFERENTIAL]

ASSEMBLY INSPECTION AND ADJUSTMENT

Total Preload Torque

1. Turn drive pinion in both directions several times to set bearing rollers.
2. Check total preload using Tool.

Tool number : ST3127S000 (J-25765-A)

Total preload (with oil seal)

Gear ratio 2.937 Type:

2.49 - 5.27 N·m (0.26 - 0.53 kg·m, 22 - 46 in·lb)

Gear ratio 3.357 Type:

2.38 - 5.16 N·m (0.25 - 0.52 kg·m, 21 - 45 in·lb)

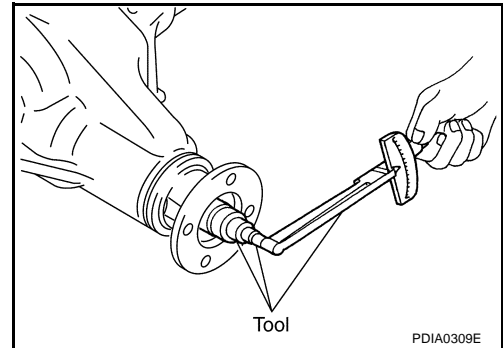

NOTE:

Total preload torque = Pinion bearing torque + Side bearing torque

- If measured value is out of the specification, disassemble it to check and adjust each part. Adjust pinion bearing preload and side bearing preload. Adjust pinion bearing preload first, then adjust side bearing preload.

When the preload torque is large

On pinion bearings: Replace collapsible spacer.

On side bearings: Loosen side bearing adjuster.

When the preload is small

On pinion bearings: Tighten drive pinion nut.

On side bearings: Tighten side bearing adjuster.

Tooth Contact

Checking gear tooth contact pattern is necessary to verify correct relationship between drive gear and drive pinion. Gears which are not positioned in proper arrangement may be noisy and/or have a short life. Check gear tooth contact pattern to obtain the best contact for low noise and long life.

1. Remove rear cover. Refer to [RFD-20, "DISASSEMBLY"](#).
2. Thoroughly clean drive gear and drive pinion teeth.
3. Apply red lead to drive gear.

CAUTION:

Apply red lead to both the faces of 3 to 4 gears at 4 locations evenly spaced on drive gear.

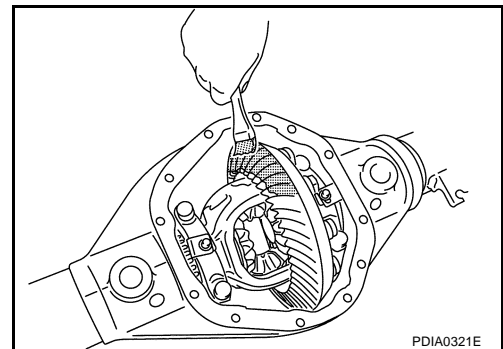

4. Hold companion flange steady by hand and rotate drive gear in both directions.

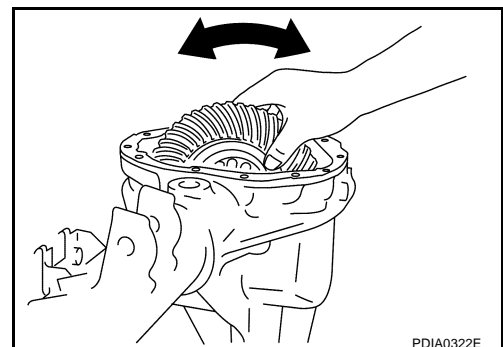

REAR FINAL DRIVE ASSEMBLY [WITHOUT ELECTRONIC LOCKING DIFFERENTIAL]

Usually the pattern will be correct if washers are correctly calculated and the backlash is correct. However, in rare cases, trial and error processes may be employed to obtain a correct pattern. The tooth pattern is the best indication of how well a differential has been set up.

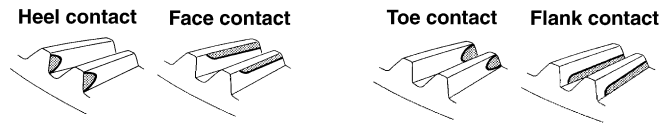

To correct, increase thickness of drive pinion height adjusting washer in order to bring drive pinion close to drive gear.

To correct, reduce thickness of drive pinion height adjusting washer in order to make drive pinion go away from drive gear.

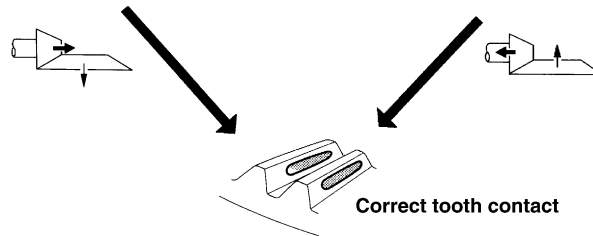

When adjustment is completed, be sure to wipe off completely the red lead and oil or their equivalent.

SDIA2591E

5. If outside the standard, adjust drive pinion height adjusting washer and backlash. Refer to [RFD-26, "Drive Pinion Height Adjusting Washer"](#) , [RFD-18, "Backlash"](#) .

Backlash

1. Remove rear cover. Refer to [RFD-20, "DISASSEMBLY"](#) .
2. Check drive gear to drive pinion backlash using a dial indicator at several points.

Drive gear to drive pinion backlash:
0.08 - 0.13 mm (0.0031 - 0.0051 in)

3. If outside the standard, adjust side bearing adjuster.

CAUTION:

Check tooth contact and total preload after adjusting side bearing adjuster. Refer to [RFD-17, "Total Preload Torque"](#) , [RFD-17, "Tooth Contact"](#) .

- a. Remove adjuster lock plate.
- b. Loosen side bearing cap bolts.
- c. Tighten or loosen each side bearing adjusters using Tool.

Tool number : — (C - 4164)

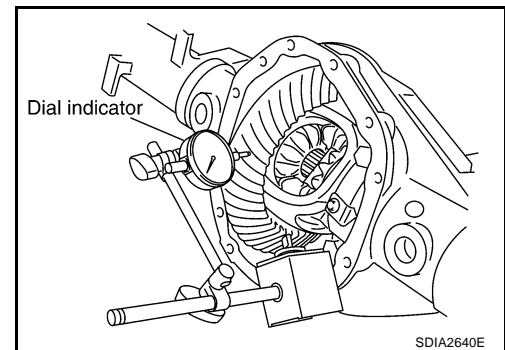

SDIA2640E

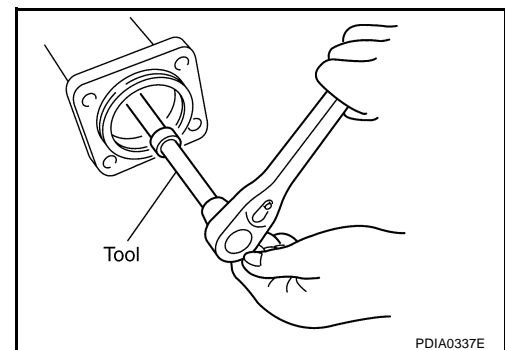

PDIA0337E

REAR FINAL DRIVE ASSEMBLY [WITHOUT ELECTRONIC LOCKING DIFFERENTIAL]

- d. In case of lots of backlash, loosen side bearing adjuster A and tighten side bearing adjuster B. In case of less backlash, loosen side bearing adjuster B and tighten side bearing adjuster A.

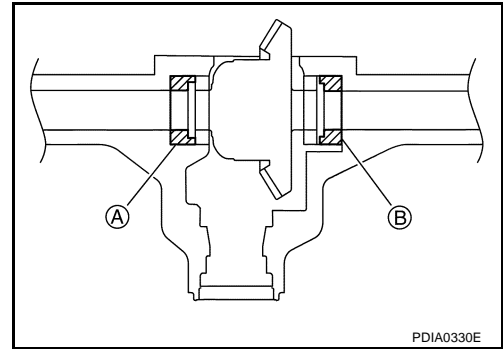

- e. After adjusting backlash and tighten cap bolts to the specified torque. Refer to [RFD-16, "COMPONENTS"](#) .
- f. Install adjuster lock plate and tighten to the specified torque. Refer to [RFD-16, "COMPONENTS"](#) .

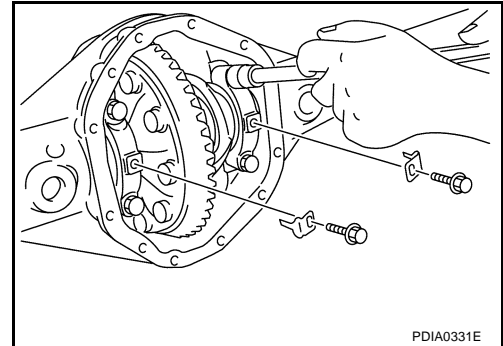

Companion Flange Runout

1. Fit a dial indicator onto companion flange face (inner side of propeller shaft bolt holes).
2. Rotate companion flange to check for runout.

Runout limit : 0.10 mm (0.0039 in) or less

3. Fit a test indicator to the inner side of companion flange (socket diameter).
4. Rotate companion flange to check for runout.

Runout limit : 0.13 mm (0.0051 in) or less

5. If the runout value is outside the repair limit, follow the procedure below to adjust.

- a. Check for runout while changing the phase between companion flange and drive pinion by 90° step, and search for the point where the runout is the minimum.
- b. If the runout value is still outside of the limit after the phase has been changed, replace companion flange.
- c. If the runout value still outside of the limit after companion flange has been replaced, check drive pinion bearing and drive pinion assembly.

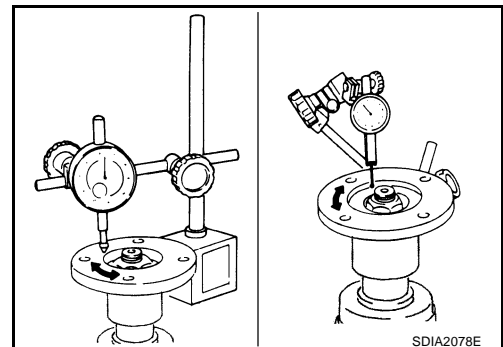

REAR FINAL DRIVE ASSEMBLY [WITHOUT ELECTRONIC LOCKING DIFFERENTIAL]

DISASSEMBLY

Differential Assembly

1. Remove carrier cover bolts.
2. Remove carrier cover using Tool.

Tool number : KV10111100 (J-37228)

CAUTION:

- Be careful not to damage the mating surface.
- Do not insert flat-bladed screwdriver, this will damage the mating surface.

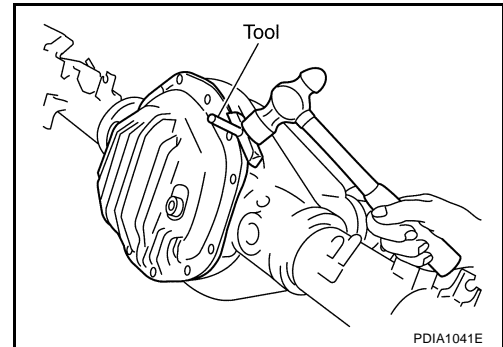

3. For proper reinstallation, paint matching mark on one side of side bearing cap.

CAUTION:

- Side bearing caps are line-board for initial assembly. The matching marks are used to reinstall them in their original positions.
- For matching mark, use paint. Do not damage side bearing cap.

4. Remove adjuster lock plates.

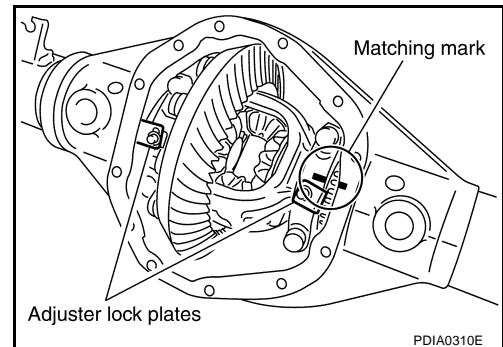

5. Remove side bearing caps.

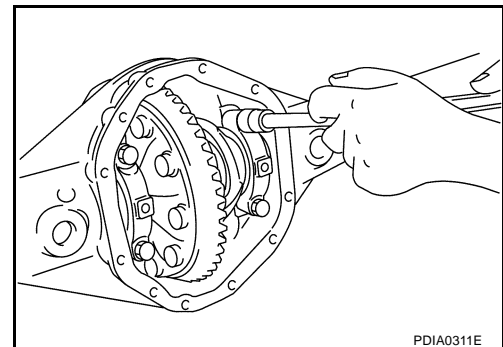

6. Remove side bearing adjusters using Tool.

Tool number : — (C - 4164)

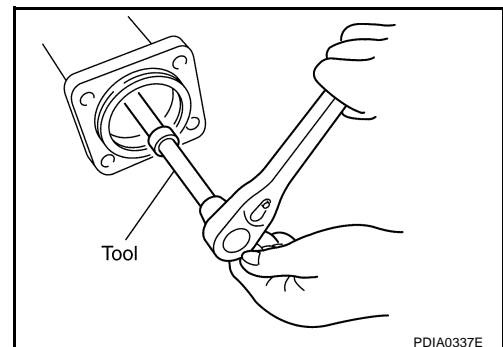

REAR FINAL DRIVE ASSEMBLY [WITHOUT ELECTRONIC LOCKING DIFFERENTIAL]

7. Keep side bearing outer races together with inner races. Do not mix them up. Also, keep side bearing adjusters together with bearing.
8. Remove side bearing adjusters from axle housing.

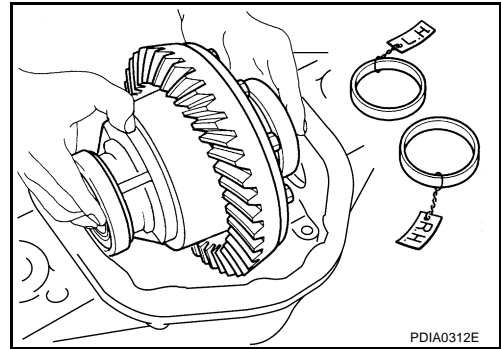

9. Remove side bearing inner races using suitable puller.

CAUTION:
Be careful not to damage differential case.

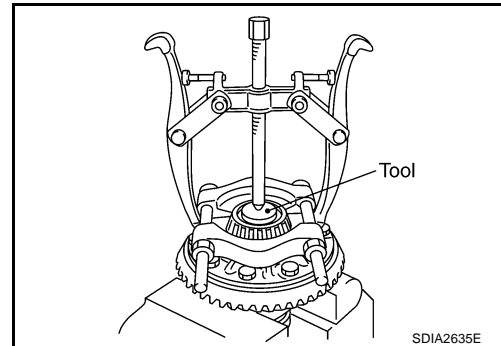

10. For proper reinstallation, paint matching mark on differential case and drive gear.

CAUTION:
For matching mark, use paint. Do not damage differential case and drive gear.

11. Remove drive gear bolts.
12. Tap drive gear off differential case with a soft hammer.

CAUTION:
Tap evenly all around to keep drive gear from binding.

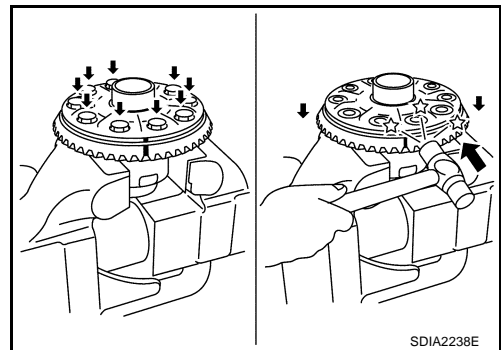

13. Pull lock pin out of pinion mate shaft, using Tool.

Tool number : ST23550000 (—)

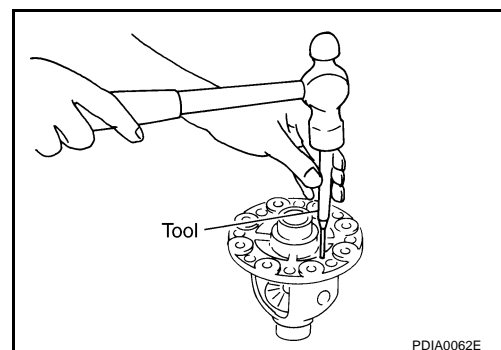

14. Remove pinion mate shaft.

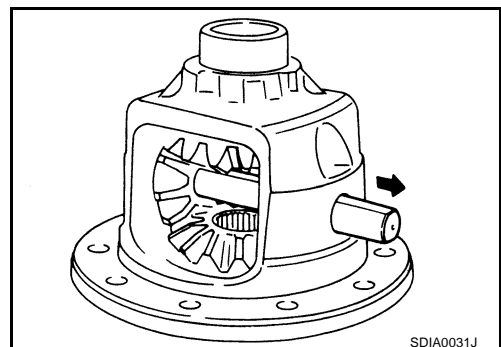

A
B
C
RFD

E
F
G
H
I
J
K
L
M

REAR FINAL DRIVE ASSEMBLY [WITHOUT ELECTRONIC LOCKING DIFFERENTIAL]

15. Turn pinion mate gear, then remove pinion mate gear, pinion mate thrust washer, side gear and side gear thrust washer from differential case.

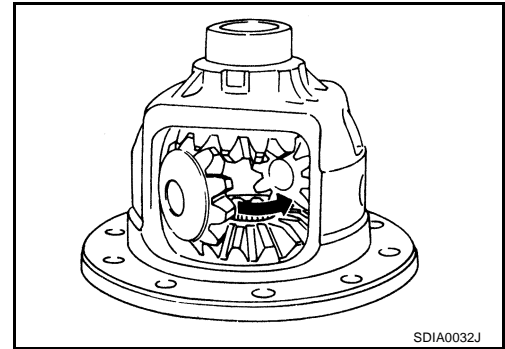

Drive Pinion Assembly

1. Remove differential case assembly. Refer to [RFD-20, "Differential Assembly"](#).
2. Remove drive pinion nut and washer using Tool.

Tool number : KV40104000 (—)

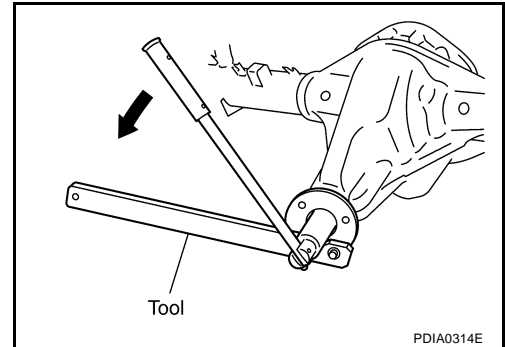

3. Put a matching mark on the thread edge of drive pinion. The mark should be in line with the mark on companion flange.

CAUTION:

For matching mark, use paint. Do not damage drive pinion.

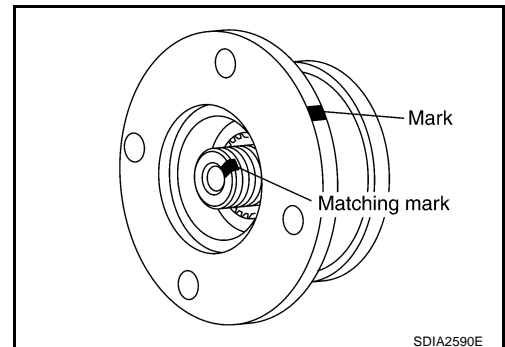

4. Remove companion flange using a suitable Tool.

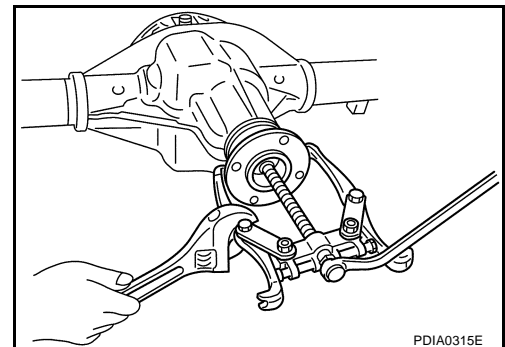

REAR FINAL DRIVE ASSEMBLY [WITHOUT ELECTRONIC LOCKING DIFFERENTIAL]

5. Remove front oil seal using Tool.

Tool number : ST33290001 (J-34286)

CAUTION:

Be careful not to damage axle housing.

6. Remove front bearing thrust washer.

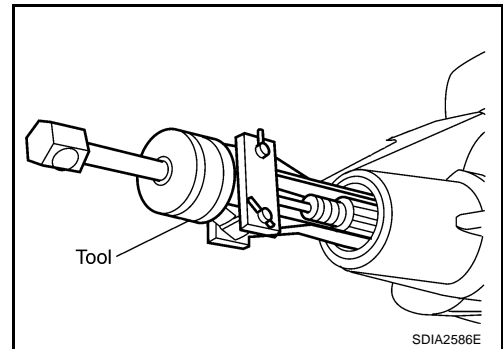

7. Remove drive pinion assembly and collapsible spacer from axle housing, using press.

CAUTION:

Do not drop drive pinion assembly.

8. Remove drive pinion front bearing inner race from axle housing.

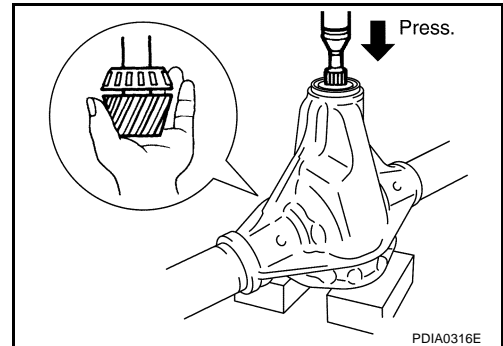

9. Tap drive pinion front bearing outer race uniformly with a brass bar or equivalent to remove.

CAUTION:

Be careful not to damage axle housing.

10. Tap drive pinion rear bearing outer race uniformly with a brass bar or equivalent for removal.

CAUTION:

Be careful not to damage axle housing.

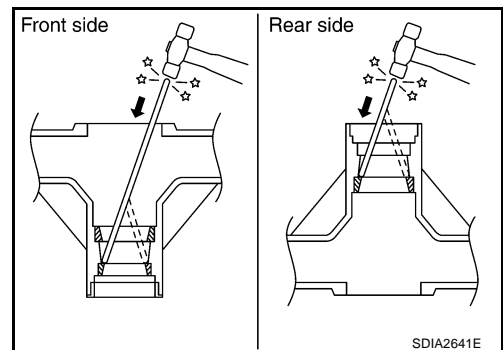

11. Remove drive pinion rear bearing inner race and drive pinion height adjusting washer, using Tool.

Tool number : ST30021000 (J-22912-01)

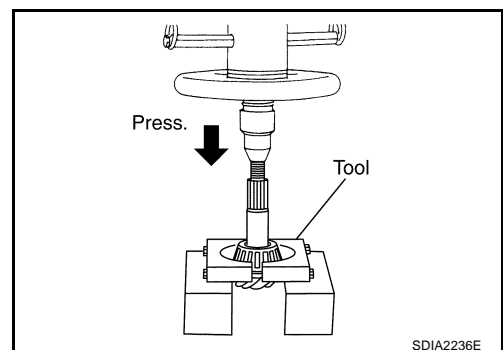

A
B
C
RFD

E
F
G
H
I
J
K
L
M

REAR FINAL DRIVE ASSEMBLY

[WITHOUT ELECTRONIC LOCKING DIFFERENTIAL]

INSPECTION AFTER DISASSEMBLY

Drive Gear and Drive Pinion

- If gear teeth do not mesh or line-up correctly, determine cause and adjust, repair, or replace as necessary.
- If gears are worn, cracked, damaged, pitted or chipped (by friction) noticeably, replace with new gears.
- Drive gear and drive pinion are supplied in matched sets only. Matching numbers on both drive pinion and drive gear are etched for verification. If a new gear set is being used, verify the numbers of each pinion gear and drive gear before proceeding with assembly.

Bearing

- If found any chipped (by friction), pitted, worn, rusted, scratched mark, or unusual noise from bearing, replace with new bearing assembly (as a new set).
- Bearing must be replaced with a new one whenever disassembled.

Side Gear, Pinion Mate and Pinion Mate Shaft

- Replace with a new one if found any cracks or damage on the surface of the tooth.
- Replace with a new one if found any worn or chipped mark on the contact sides of thrust washer.
- Replace both side gear and pinion mate gear as a set when replacing side gear or pinion mate gear.

Side Gear Thrust Washer and Pinion Mate Thrust Washer

- Replace with a new one if found that it is chipped (by friction), damaged, or unusual worn.

Differential Case

- Replace with a new one if found any wear or cracks on the contact sides of differential case.

REAR FINAL DRIVE ASSEMBLY [WITHOUT ELECTRONIC LOCKING DIFFERENTIAL]

SELECTION ADJUSTING WASHERS

Side Gear Thrust Washer

1. Place differential case straight up so that side gear to be measured comes upward.

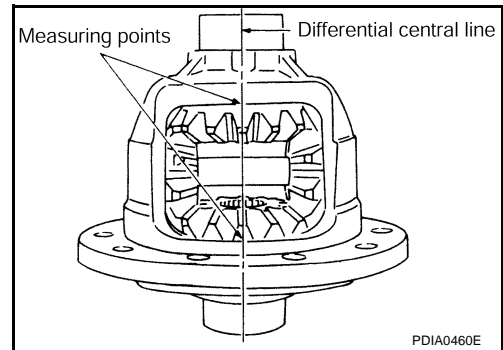

2. Using a thickness gauge, measure the clearance between side gear back and differential case at 3 different points, while rotating side gear. Average the 3 readings, and then measure the clearance. (Measure the clearance of the other side as well.)

Side gear back clearance standard:

0.305 mm (0.0120 in) or less.

(Each gear should rotate smoothly without excessive resistance during differential motion.)

CAUTION:

To prevent side gear from tilting, insert thickness gauges with the same thickness from both sides.

3. If the back clearance is outside the standard, use a thicker/thinner side gear thrust washer to adjust.

When the back clearance is large:

Use a thicker thrust washer.

When the back clearance is small:

Use a thinner thrust washer.

CAUTION:

Select a side gear thrust washer for right and left individually.

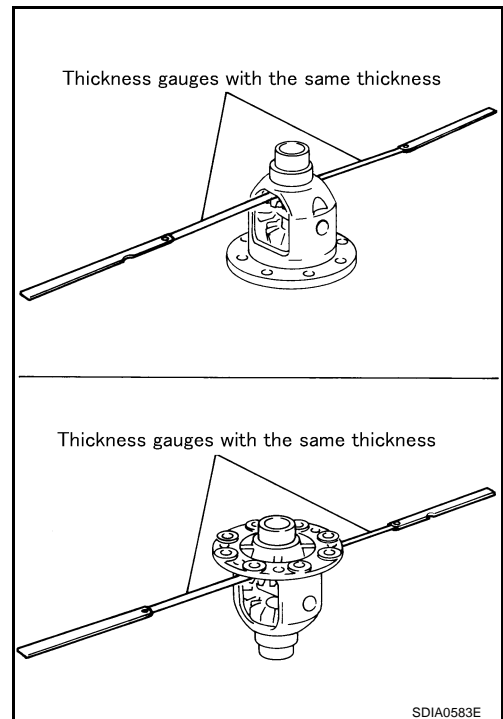

A
B
C
RFD
E
F
G
H
I
J
K
L
M

REAR FINAL DRIVE ASSEMBLY [WITHOUT ELECTRONIC LOCKING DIFFERENTIAL]

Drive Pinion Height Adjusting Washer

- Drive gear and drive pinion are supplied in matched sets only. Matching numbers on both drive pinion and drive gear are etched for verification. If a new gear set is being used, verify the numbers of each drive pinion and drive gear before proceeding with assembly.

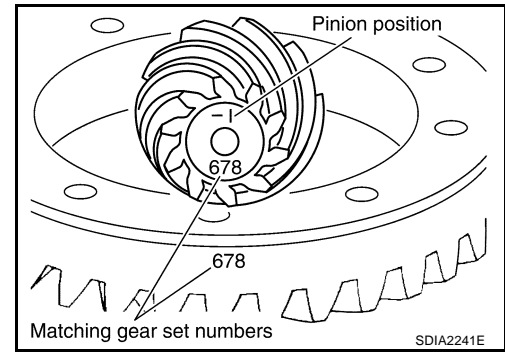

- The mounting distance from the center line of drive gear to the back face of drive pinion for the Model 226 axle assembly is 109.5 mm (4.312 in). On the button end of each drive pinion, there is etched a plus (+) number, a minus (-) number, or a zero (0), which indicates the best running position for each particular gear set. This dimension is controlled by a selective drive pinion height adjusting washer between drive pinion inner bearing race and drive pinion. For example: If a drive pinion is etched m+8 (+3), it would require 0.08 mm (0.003 in) less drive pinion height adjusting washer than a drive pinion etched "0". This means decreasing drive pinion height adjusting washer thickness; increases the mounting distance of drive pinion to 109.6 mm (4.315 in). If a drive pinion is etched m-8 (-3), it would require adding 0.08 mm (0.003 in) more to drive pinion height adjusting washer than would be required if drive pinion were etched "0". By adding 0.08 mm (0.003 in), the mounting distance of drive pinion was decreased to 109.4 mm (4.309 in) which is just what m-8 (a-3) etching indicated.
- To change drive pinion adjustment, use different drive pinion height adjusting washers which come in different thickness.
- Use the following tables as a guide for selecting the correct drive pinion height adjusting washer thickness to add or subtract from the old drive pinion height adjusting washer.

OLD DRIVE PINION MARKING	NEW DRIVE PINION MARKING mm (in)								
	-4	-3	-2	-1	0	+1	+2	+3	+4
+4	+0.20 (+0.008)	+0.18 (+0.007)	+0.15 (+0.006)	+0.13 (+0.005)	+0.10 (+0.004)	+0.08 (+0.003)	+0.05 (+0.002)	+0.02 (+0.001)	0 (0)
+3	+0.18 (+0.007)	+0.15 (+0.006)	+0.13 (+0.005)	+0.10 (+0.004)	+0.08 (+0.003)	+0.05 (+0.002)	+0.02 (+0.001)	0 (0)	-0.02 (-0.001)
+2	+0.15 (+0.006)	+0.13 (+0.005)	+0.10 (+0.004)	+0.08 (+0.003)	+0.05 (+0.002)	+0.02 (+0.001)	0 (0)	-0.02 (-0.001)	-0.05 (-0.002)
+1	+0.13 (+0.005)	+0.10 (+0.004)	+0.08 (+0.003)	+0.05 (+0.002)	+0.02 (+0.001)	0 (0)	-0.02 (-0.001)	-0.05 (-0.002)	-0.08 (-0.003)
0	+0.10 (+0.004)	+0.08 (+0.003)	+0.05 (+0.002)	+0.02 (+0.001)	0 (0)	-0.02 (-0.001)	-0.05 (-0.002)	-0.08 (-0.003)	-0.10 (-0.004)
-1	+0.08 (+0.003)	+0.05 (+0.002)	+0.02 (+0.001)	0 (0)	-0.02 (-0.001)	-0.05 (-0.002)	-0.08 (-0.003)	-0.10 (-0.004)	-0.13 (-0.005)
-2	+0.05 (+0.002)	+0.02 (+0.001)	0 (0)	-0.02 (-0.001)	-0.05 (-0.002)	-0.08 (-0.003)	-0.10 (-0.004)	-0.13 (-0.005)	-0.15 (-0.006)
-3	+0.02 (+0.001)	0 (0)	-0.02 (-0.001)	-0.05 (-0.002)	-0.08 (-0.003)	-0.10 (-0.004)	-0.13 (-0.005)	-0.15 (-0.006)	-0.18 (-0.007)
-4	0 (0)	-0.02 (-0.001)	-0.05 (-0.002)	-0.08 (-0.003)	-0.10 (-0.004)	-0.13 (-0.005)	-0.15 (-0.006)	-0.18 (-0.007)	-0.20 (-0.008)

REAR FINAL DRIVE ASSEMBLY [WITHOUT ELECTRONIC LOCKING DIFFERENTIAL]

1. Make sure all parts are clean and that drive pinion bearings are well lubricated.
2. Assemble drive pinion bearings into Tools.

Tool number	A: —	(8144)
	B: —	(6740)
	C: —	(6741)

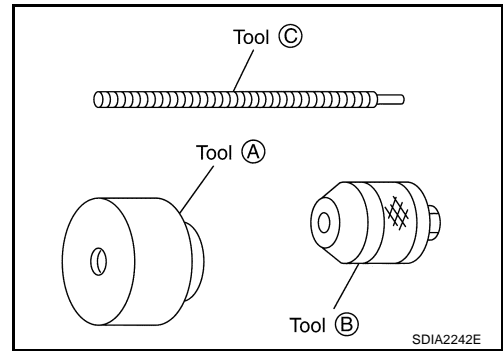

3. Install drive pinion bearing inner race and drive pinion height adjusting washer to axle housing using tool as shown.

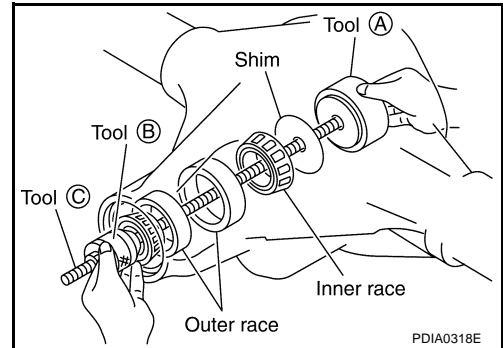

4. Turn the assembly several times to seat drive pinion bearings.

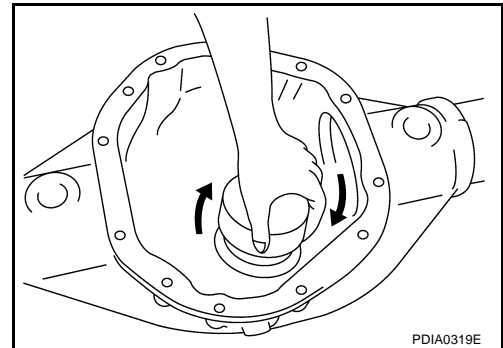

5. Measure the turning torque, using Tool.

Tool number : **ST3127S000 (J-25765-A)**

Turning torque specification

: 1.2 - 2.8 N-m (0.13 - 0.28 kg-m, 11 - 24 in-lb)

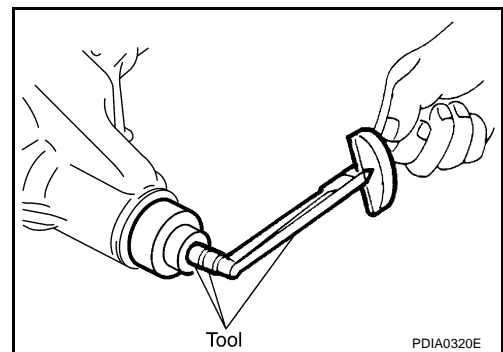

6. Tighten side bearing caps to the specified torque installing Tools as shown.

Tool number	A: —	(6739)
	B: —	(D-115-2)
	C: —	TBD
	D: —	(D-115-3)

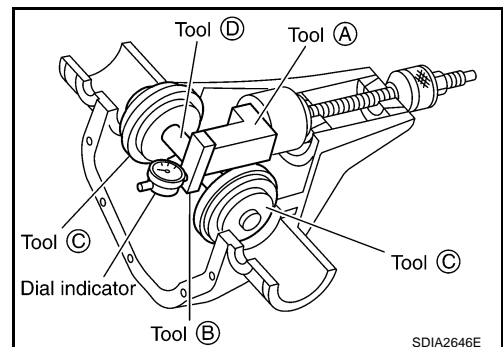

A
B
C
RFD
E
F
G
H
I
J
K
L
M

REAR FINAL DRIVE ASSEMBLY [WITHOUT ELECTRONIC LOCKING DIFFERENTIAL]

7. Put scooter block on pinion height block. Make sure that dial indicator is level adjusting pressure with a hand. Dial indicator indicates "0".
8. Slide dial indicator along arbor. Record the maximum.
9. Adjust drive pinion height adjusting washer so that the maximum will be "0".

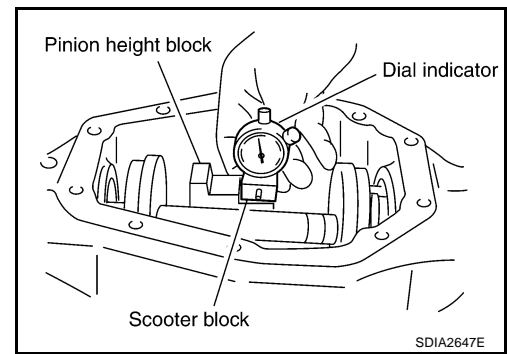

ASSEMBLY

Drive Pinion Assembly

1. Press a drive pinion rear bearing outer race into axle housing, using Tools.

Tool number **A: ST01500001 (—)**
 B: ST30022000 (—)

CAUTION:
Do not reuse drive pinion rear bearing.

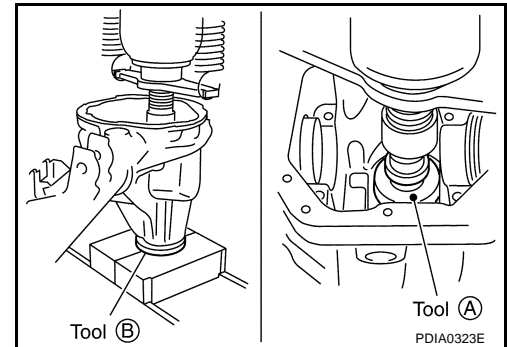

2. Press a drive pinion front bearing outer race into axle housing, using Tool.

Tool number : **ST33022000 (—)**

CAUTION:
Do not reuse drive pinion front bearing.

3. Select drive pinion height adjusting washer. Refer to [RFD-26, "Drive Pinion Height Adjusting Washer"](#) .

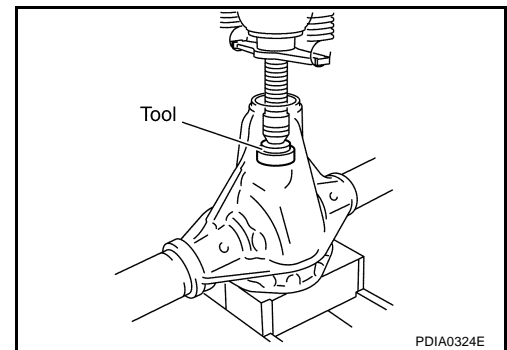

4. Press a new drive pinion rear bearing inner race and drive pinion height adjusting washer to drive pinion, using Tool.

Tool number : — **(C - 4040)**

CAUTION:
Do not reuse drive pinion rear bearing.

5. Apply gear oil to drive pinion rear bearing and drive pinion front bearing.
6. Install drive pinion front bearing inner race in axle housing.
7. Install front bearing thrust washer to axle housing.

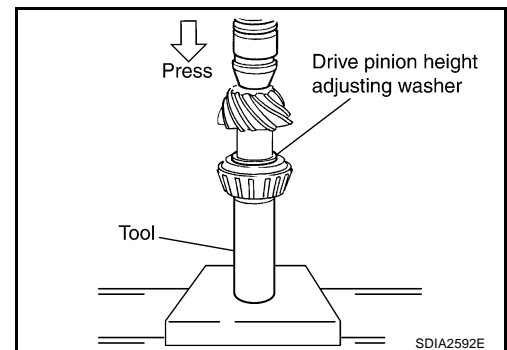

REAR FINAL DRIVE ASSEMBLY [WITHOUT ELECTRONIC LOCKING DIFFERENTIAL]

8. Apply multi-purpose grease to new front oil seal lip. Install front oil seal into axle housing using Tool.

Tool number : ST15310000 (—)

CAUTION:

- Do not reuse oil seal.
- When installing, do not incline oil seal.

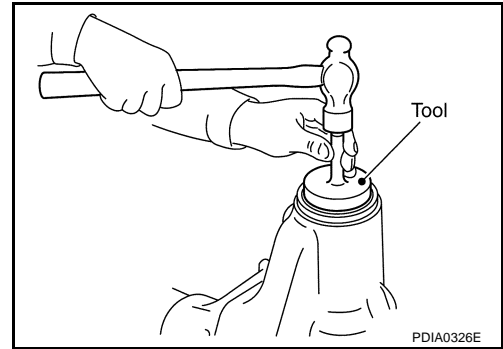

9. Install new collapsible spacer to drive pinion. And then install drive pinion assembly in axle housing.

CAUTION:

- Do not reuse collapsible spacer.
- Be careful not to damage front oil seal.

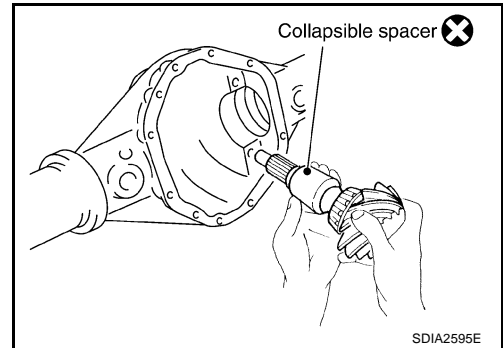

10. Align the matching mark of drive pinion with the mark of companion flange.

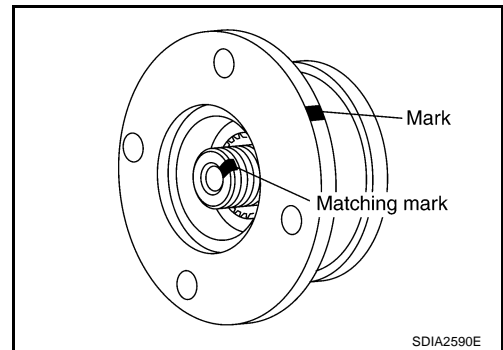

11. Install companion flange onto drive pinion. Tap companion flange with a soft hammer until fully seated.

CAUTION:

Be careful not to damage companion flange and front oil seal.

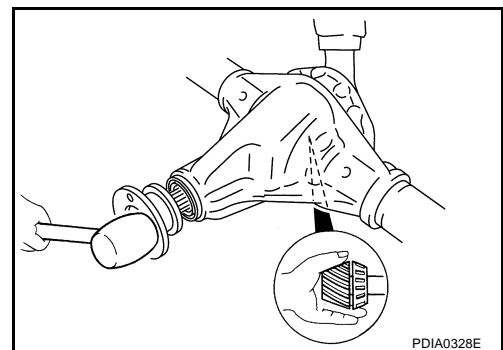

12. Install new drive pinion nut and drive pinion nut washer. Tighten drive pinion nut until total preload is within specification.

- The threaded portion of drive pinion and drive pinion nut should be free from oil or grease.

Tool number : KV40104000 (—)

CAUTION:

Do not reuse drive pinion nut and drive pinion nut washer.

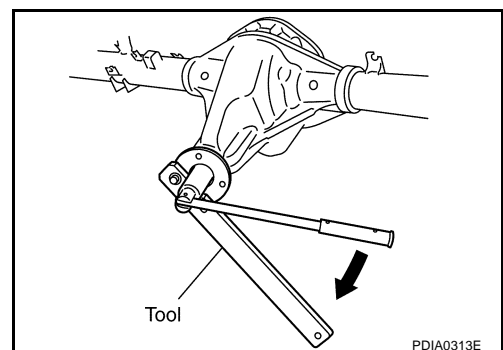

A
B
C
RFD

E
F
G
H
I
J
K
L
M

REAR FINAL DRIVE ASSEMBLY [WITHOUT ELECTRONIC LOCKING DIFFERENTIAL]

13. Tighten drive pinion nut by very small degrees until the specified preload is achieved. When checking the preload, turn drive pinion in both directions several times to set the bearing rollers, using Tool.

Tool number : ST3127S000 (J-25765-A)

Pinion bearing preload

: 1.7 - 3.8 N·m (0.18 - 0.38 kg·m, 15 - 33 in·lb)

- a. This procedure will have to be repeated if:
- Maximum preload is achieved before the minimum drive pinion nut torque is reached.
 - Minimum preload is not achieved before maximum drive pinion nut torque is reached.

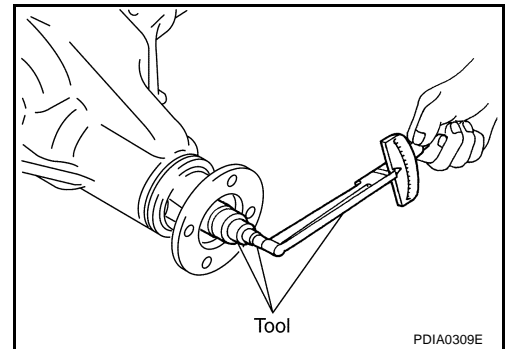

Differential Assembly

1. Assemble side gear thrust washers with the same thickness as the ones installed prior to disassembly or reinstall the old ones on side gears.
2. Assemble side gear and side gear thrust washer into differential case.

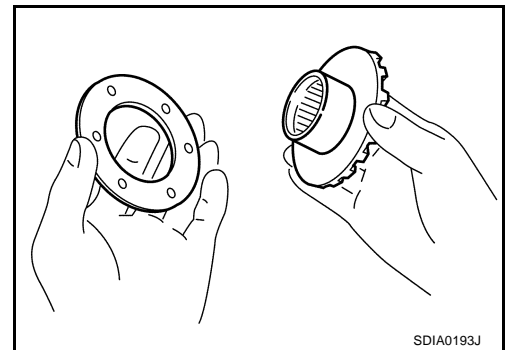

3. Align 2 pinion mate gears in diagonally opposite positions, then rotate and assemble them into differential case after assembling pinion mate thrust washer to pinion mate gear.

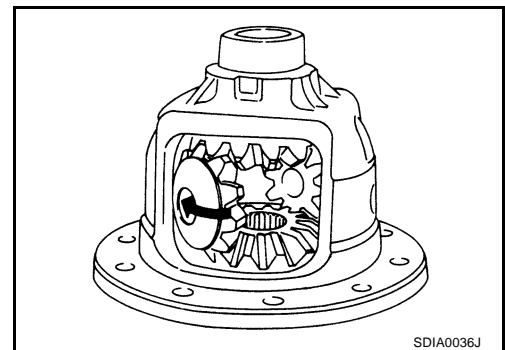

4. Align lock pin holes on differential case and shaft, and assemble pinion mate shaft.
5. Measure side gear end play. If necessary, select the appropriate side gear thrust washers. Refer to [RFD-25, "Side Gear Thrust Washer"](#).

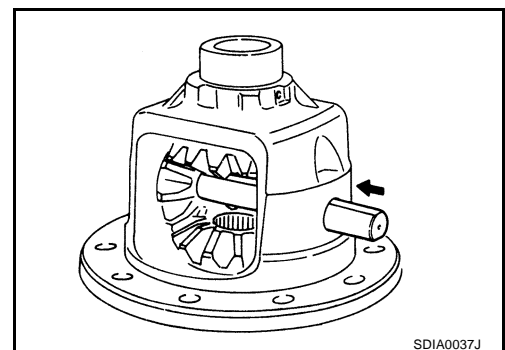

REAR FINAL DRIVE ASSEMBLY [WITHOUT ELECTRONIC LOCKING DIFFERENTIAL]

6. Drive a new lock pin into pinion mate shaft, using Tool.

Tool number : ST23550000 (—)

CAUTION:

Do not reuse lock pin.

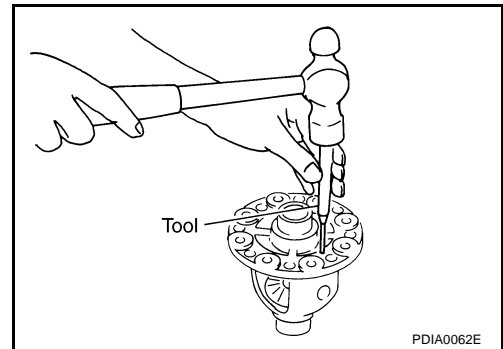

PDIA0062E

7. Apply gear oil to gear tooth surfaces and thrust surfaces and check to see they turn properly.

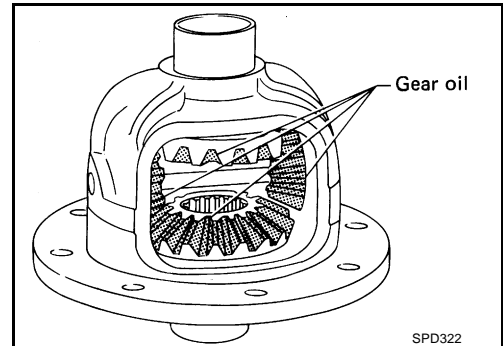

SPD322

8. Apply thread locking sealant to the back face of drive gear as shown.

- Use Genuine High Strength Thread Locking Sealant Loctite 648 or equivalent. Refer to [GI-45, "Recommended Chemical Products and Sealants"](#).

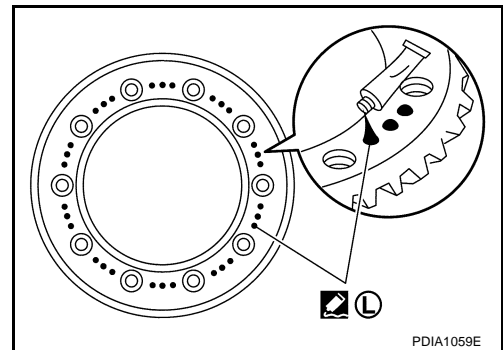

PDIA1059E

9. Align the matching mark of differential case with the mark of drive gear, then install drive gear.

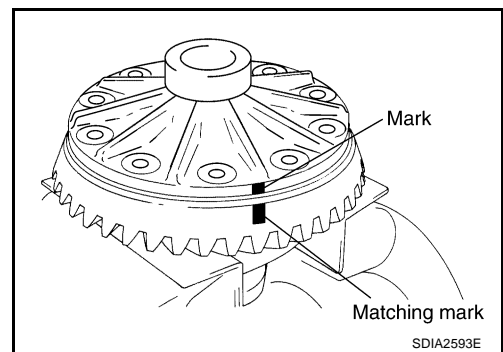

SDIA2593E

10. Apply thread locking sealant into the thread hole of drive gear.

- Use Genuine Medium Strength Thread Locking Sealant or equivalent. Refer to [GI-45, "Recommended Chemical Products and Sealants"](#).

CAUTION:

Drive gear back and threaded holes shall be cleaned and decreased sufficiently.

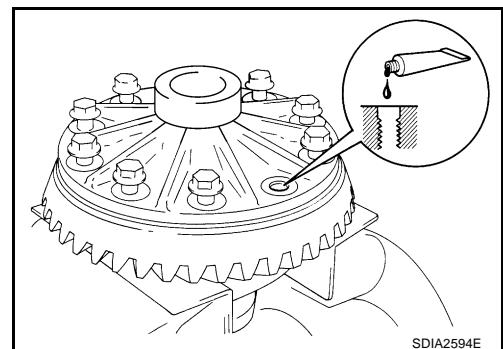

SDIA2594E

A
B
C
RFD
E
F
G
H
I
J
K
L
M

REAR FINAL DRIVE ASSEMBLY [WITHOUT ELECTRONIC LOCKING DIFFERENTIAL]

11. Install new drive gear on the bolts, and then tighten to the specified torque. Refer to [RFD-16, "COMPONENTS"](#).

CAUTION:

- Do not reuse the bolts.
- Tighten bolts in a crisscross fashion.

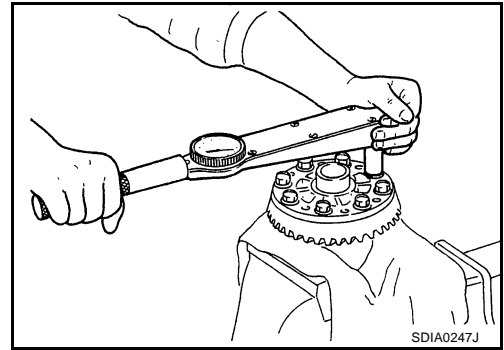

12. Press new side bearing inner races to differential case using Tools.

Tool number **A: KV38100300 (J-25523)**

B: ST33081000 (—)

CAUTION:

Do not reuse side bearing.

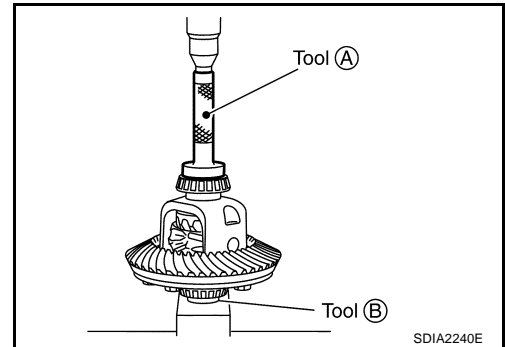

13. Install side bearing adjusters into axle housing.

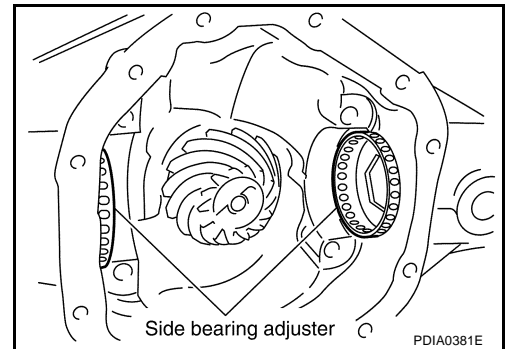

14. Apply gear oil to side bearings. Install differential case assembly with side bearing outer races into axle housing.

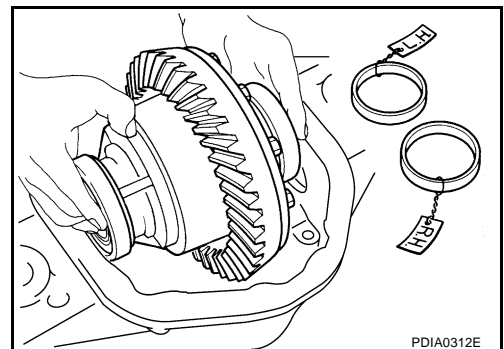

15. Align paint matching mark on side bearing caps with that on axle housing and install side bearing caps on axle housing.

CAUTION:

Do not tighten at this point. This allows further tightening of side bearing adjusters.

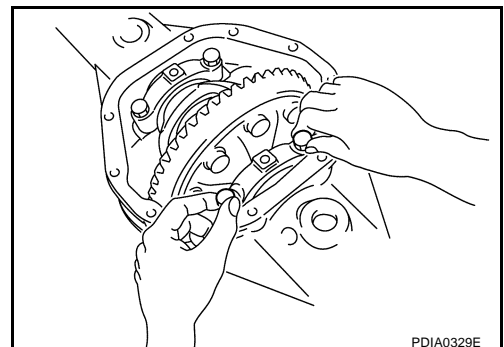

REAR FINAL DRIVE ASSEMBLY [WITHOUT ELECTRONIC LOCKING DIFFERENTIAL]

16. Tighten each side bearing adjusters using Tool.

Tool number : — (C - 4164)

17. Adjusting backlash of drive gear and drive pinion. Refer to [RFD-18, "Backlash"](#) .

18. Check total preload. Refer to [RFD-17, "Total Preload Torque"](#) .

19. Check tooth contact. Refer to [RFD-17, "Tooth Contact"](#) .

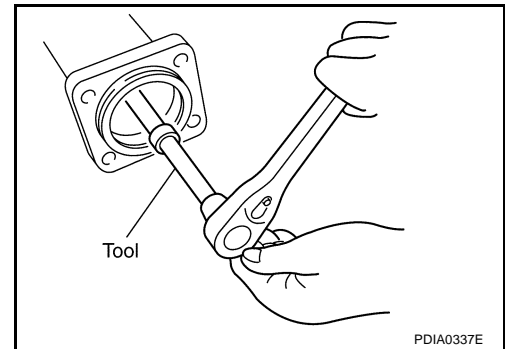

20. Apply sealant to mating surface of carrier cover.

- Use Genuine Silicone RTV or equivalent. Refer to [GI-45, "Recommended Chemical Products and Sealants"](#) .

CAUTION:

Remove old sealant adhering to mounting surfaces. Also remove any moisture, oil, or foreign material adhering to application and mounting surfaces.

21. Install carrier cover on axle housing and tighten carrier cover bolts with the specified torque. Refer to [RFD-16, "COMPONENTS"](#) .

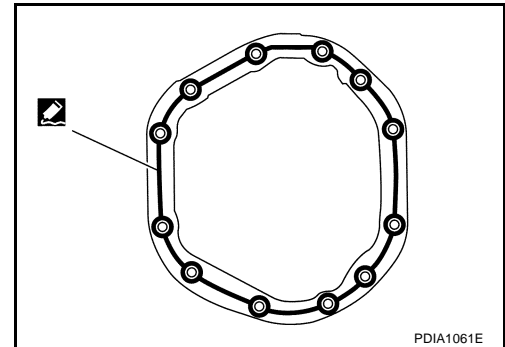

A

B

C

RFD

E

F

G

H

I

J

K

L

M

SERVICE DATA AND SPECIFICATIONS (SDS)
[WITHOUT ELECTRONIC LOCKING DIFFERENTIAL]

SERVICE DATA AND SPECIFICATIONS (SDS)

PFP:00030

General Specifications

EDS003N0

Engine	VK56DE	
Vehicle grade	Standard	Tow package or off road package
Transmission	5A/T	
Final drive model	M226	
Gear ratio	2.937	3.357
Number of pinion gears	2	
Number of teeth (Drive gear / drive pinion)	47/16	47/14
Oil capacity (Approx.) \varnothing (US pt, Imp pt)	2.01 (4-1/4, 3-1/2)	
Drive pinion adjustment spacer type	Collapsible	

Inspection and Adjustment
DIFFERENTIAL SIDE GEAR CLEARANCE

EDS003NR

Unit: mm (in)

Item	Standard
Side gear backlash (Clearance between side gear and differential case)	0.305 (0.0120) or less. (Each gear should rotate smoothly without excessive resistance during differential motion.)

PRELOAD TORQUE

Unit: N-m (kg-m, in-lb)

Item	Specification	
	Gear ratio 2.937 Type	Gear ratio 3.357 type
Total preload (Drive pinion torque to rotate plus)	2.49 - 5.27 (0.26 - 0.53, 22 - 46)	2.38 - 5.16 (0.25 - 0.52, 21 - 45)
Drive pinion bearing preload	1.7 - 3.8 (0.18 - 0.38, 15 - 33)	

BACKLASH

Unit: mm (in)

Item	Standard
Drive gear to drive pinion gear	0.08 - 0.13 (0.0031 - 0.0051)

COMPANION FLANGE RUNOUT

Unit: mm (in)

Item	Runout limit
Companion flange face	0.10 (0.0039) or less
Inner side of companion flange	0.13 (0.0051) or less

**SERVICE DATA AND SPECIFICATIONS (SDS)
[WITHOUT ELECTRONIC LOCKING DIFFERENTIAL]**

SELECTIVE PARTS

Side Gear Thrust Washer

Unit: mm (in)

Thickness	Package part number*
0.76 (0.030) 0.79 (0.031) 0.81 (0.032) 0.84 (0.033) 0.86 (0.034)	38424 8S101
0.89 (0.035) 0.91 (0.036) 0.94 (0.037) 0.97 (0.038) 0.99 (0.039)	38424 8S102

A
B
C

RFD

*Always check with the parts department for the latest parts information.

Drive Pinion Height Adjusting Washer

Unit: mm (in)

Thickness	Package part number*
0.076 (0.030) 0.079 (0.031) 0.081 (0.032) 0.084 (0.033) 0.086 (0.034)	38151 8S101
0.089 (0.035) 0.091 (0.036) 0.094 (0.037) 0.097 (0.038) 0.099 (0.039)	38151 8S102
0.102 (0.040) 0.104 (0.041) 0.107 (0.042) 0.109 (0.043) 0.112 (0.044)	38151 8S103
0.114 (0.045) 0.117 (0.046) 0.119 (0.047) 0.122 (0.048) 0.124 (0.049)	38151 8S104
0.127 (0.050) 0.130 (0.051) 0.132 (0.052) 0.135 (0.053) 0.137 (0.054)	38151 8S105

F
G
H
I
J
K
L
M

*Always check with the Parts Department for the latest parts information.

PRECAUTIONS

[WITH ELECTRONIC LOCKING DIFFERENTIAL]

PRECAUTIONS

PFP:00001

Precautions for Supplemental Restraint System (SRS) "AIR BAG" and "SEAT BELT PRE-TENSIONER"

EDS003NS

The Supplemental Restraint System such as "AIR BAG" and "SEAT BELT PRE-TENSIONER", used along with a front seat belt, helps to reduce the risk or severity of injury to the driver and front passenger for certain types of collision. This system includes seat belt switch inputs and dual stage front air bag modules. The SRS system uses the seat belt switches to determine the front air bag deployment, and may only deploy one front air bag, depending on the severity of a collision and whether the front occupants are belted or unbelted. Information necessary to service the system safely is included in the SRS and SB section of this Service Manual.

WARNING:

- To avoid rendering the SRS inoperative, which could increase the risk of personal injury or death in the event of a collision which would result in air bag inflation, all maintenance must be performed by an authorized NISSAN/INFINITI dealer.
- Improper maintenance, including incorrect removal and installation of the SRS, can lead to personal injury caused by unintentional activation of the system. For removal of Spiral Cable and Air Bag Module, see the SRS section.
- Do not use electrical test equipment on any circuit related to the SRS unless instructed to in this Service Manual. SRS wiring harnesses can be identified by yellow and/or orange harnesses or harness connectors.

Precautions

EDS003NT

- Before connecting or disconnecting differential lock control unit harness connector, turn ignition switch "OFF" and disconnect the battery cable from the negative terminal. Because battery voltage is applied to differential lock control unit even if ignition switch is turned "OFF".

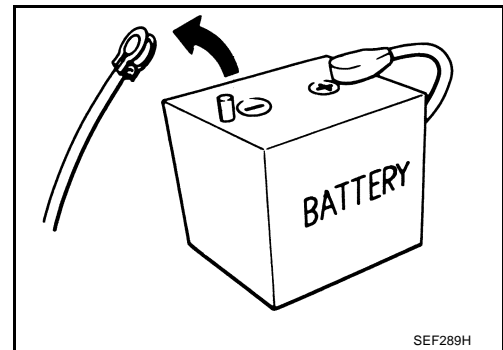

- When connecting or disconnecting pin connectors into or from differential lock control unit, take care not to damage pin terminals (bend or break). When connecting pin connectors make sure that there are not any bends or breaks on differential lock control unit pin terminal.

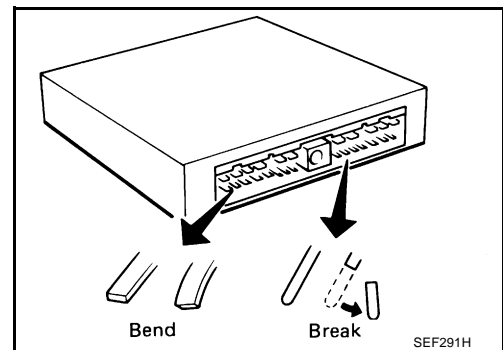

- Before replacing differential lock control unit, perform differential lock control unit input/output signal inspection and make sure whether differential lock control unit functions properly or not. Refer to [RFD-52, "Differential Lock Control Unit Input/Output Signal Reference Values"](#).

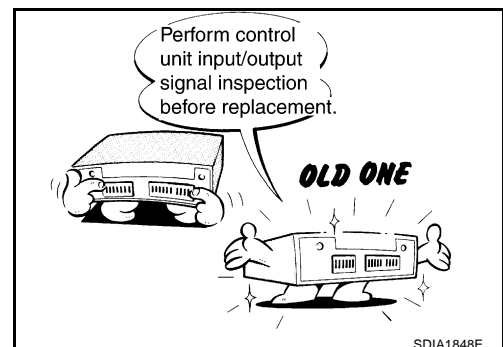

PRECAUTIONS [WITH ELECTRONIC LOCKING DIFFERENTIAL]

Service Notice or Precaution

EDS003NV

- Check for the correct installation status prior to removal or disassembly. If matching marks are required, be certain they do not interfere with the function of the parts when applied.
- Overhaul should be done in a clean work area, it is preferable to work in dustproof area.
- Before disassembly, using steam or white gasoline, completely remove sand and mud from the exterior of the unit, preventing them from entering into the unit during disassembly or assembly.
- Check appearance of the disassembled parts for damage, deformation, and unusual wear. Replace them with a new ones if necessary.
- Gaskets, seals and O-rings should be replaced any time when the unit is disassembled.
- In principle, tighten bolts or nuts gradually in several steps working diagonally from inside to outside. If tightening sequence is specified, observe it.
- Clean and flush the parts sufficiently and blow-dry them.
- Be careful not to damage sliding surfaces and mating surfaces.
- When applying sealant, remove the old sealant from the mounting surface; then remove any moisture, oil, and foreign materials from the application and mounting surfaces.
- Always use shop paper for cleaning the inside of components.
- Avoid using cotton gloves or shop rags to prevent entering of lint.
- During assembly, observe the specified tightening torque, and apply new differential gear oil, petroleum jelly, or multi-purpose grease as specified for each vehicle, if necessary.

A

B

C

RFD

E

F

G

Precautions for Liquid Gasket REMOVAL OF LIQUID GASKET SEALING

EDS003NV

- After removing the bolts and nuts, separate the mating surface and remove the old liquid gasket sealing using Tool.

Tool number : KV10111100 (J-37228)

CAUTION:

Do not damage the mating surfaces.

- Tap the seal cutter to insert it.
- In areas where the Tool is difficult to use, lightly tap to slide it.

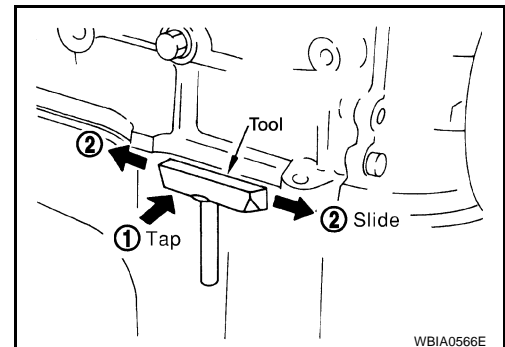

H

I

J

K

LIQUID GASKET APPLICATION PROCEDURE

1. Remove the old liquid gasket adhering to the gasket application surface and the mating surface using suitable tool.
 - Remove the liquid gasket completely from the groove of the liquid gasket application surface, bolts, and bolt holes.
2. Thoroughly clean the mating surfaces and remove adhering moisture, grease and foreign material.

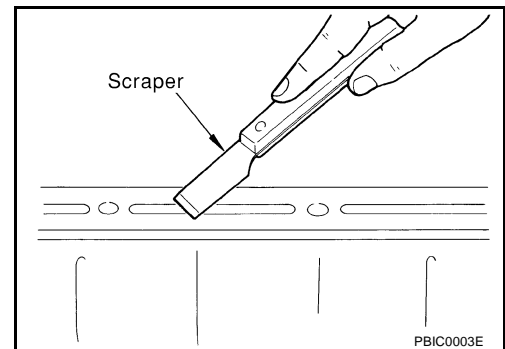

L

M

PRECAUTIONS [WITH ELECTRONIC LOCKING DIFFERENTIAL]

3. Attach the liquid gasket tube to the Tool.

Tool number : WS39930000 (—)

Use Genuine RTV Silicone Sealant or equivalent. Refer to MA-11, "RECOMMENDED FLUIDS AND LUBRICANTS" .

4. Apply the liquid gasket without breaks to the specified location with the specified dimensions.

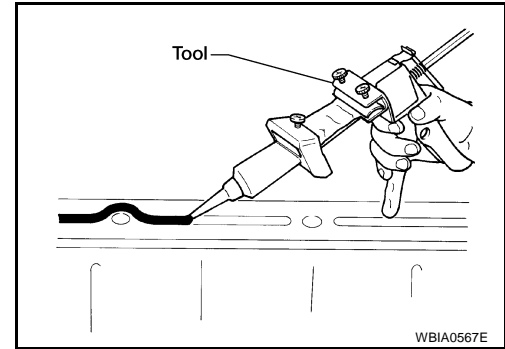

- If there is a groove for the liquid gasket application, apply the liquid gasket to the groove.
- As for the bolt holes, normally apply the liquid gasket inside the holes. If specified in the procedure, it should also be applied outside the holes.
- Within five minutes of liquid gasket application, install the mating component.
- If the liquid gasket protrudes, wipe it off immediately.
- Do not retighten after the installation.
- Wait 30 minutes or more after installation before refilling the engine with engine oil and engine coolant.

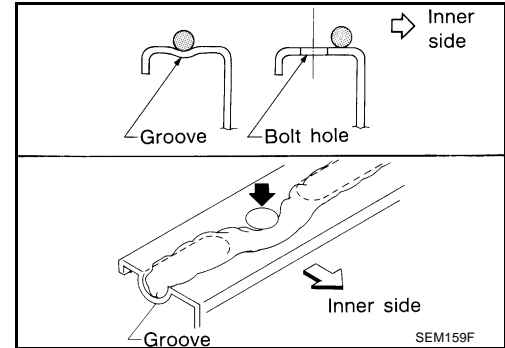

CAUTION:

If there are specific instructions in this manual, observe them.

PREPARATION [WITH ELECTRONIC LOCKING DIFFERENTIAL]

PREPARATION

PF0:00002

Special Service Tools

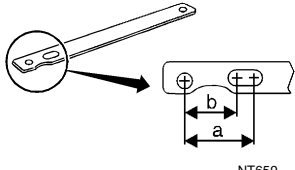
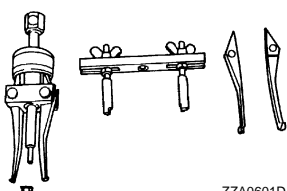
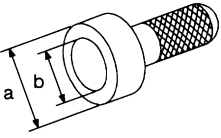
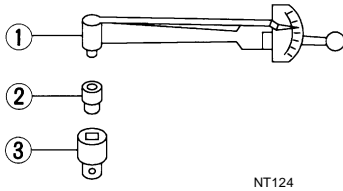
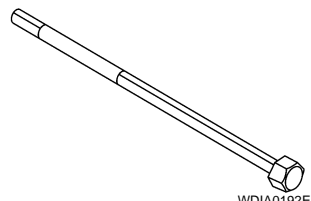
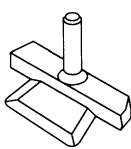

EDS003NW

The actual shapes of Kent-Moore tools may differ from those of special service tools illustrated here.

Tool number (Kent-Moore No.) Tool name	Description
KV40104000 (—) Flange wrench <div style="text-align: center;">  <p>NT659</p> </div>	Removing and installing drive pinion nut a: 85 mm (3.35 in) dia. b: 65 mm (2.56 in) dia.
ST33290001 (J-34286) Puller <div style="text-align: center;">  <p>ZZA0601D</p> </div>	Removing front oil seal
ST15310000 (—) Drift <div style="text-align: center;">  <p>NT115</p> </div>	Installing front oil seal a: 96mm (3.77 in) dia. b: 84 mm (3.30 in) dia.
ST3127S000 (J-25765-A) Preload gauge set 1. GG91030000 (J-25765) Torque wrench 2. HT62940000 (1/2") (—) Socket adapter 3. HT62900000 (3/8") (—) Socket adapter <div style="text-align: center;">  <p>NT124</p> </div>	Inspecting drive pinion bearing preload and total preload
— (C-4164) Adjuster tool <div style="text-align: center;">  <p>WDIA0192E</p> </div>	Removing and installing side bearing ad- juster
KV10111100 (J-37228) Seal cutter <div style="text-align: center;">  <p>S-NT046</p> </div>	Removing carrier cover

A
B
C
RFD
E
F
G
H
I
J
K
L
M

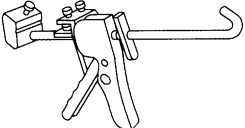
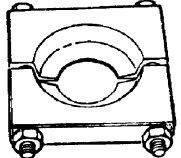
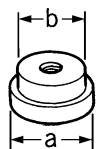
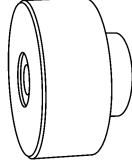
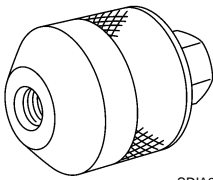
PREPARATION [WITH ELECTRONIC LOCKING DIFFERENTIAL]

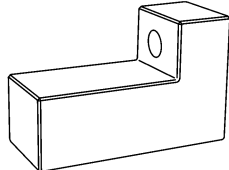
Tool number (Kent-Moore No.) Tool name	Description
WS39930000 (—) Tube presser <div style="text-align: center;">  <small>S-NT052</small> </div>	Pressing the tube of liquid gasket
ST30021000 (J-22912-01) Puller <div style="text-align: center;">  <small>ZZA0700D</small> </div>	Removing drive pinion rear bearing inner race
ST33081000 (—) Adapter <div style="text-align: center;">  <small>ZZA1000D</small> </div>	Removing and installing side bearing inner race a: 43 mm (1.69 in) dia. b: 33.5 mm (1.32 in) dia.
— (8144) Pinion block <div style="text-align: center;">  <small>SDIA2599E</small> </div>	Adjusting pinion gear height
— (6740) Cone <div style="text-align: center;">  <small>SDIA2601E</small> </div>	Adjusting pinion gear height
— (6741) Screw <div style="text-align: center;">  <small>SDIA2602E</small> </div>	Adjusting pinion gear height
— (6739) Pinion height lock <div style="text-align: center;">  <small>SDIA2603E</small> </div>	Adjusting pinion gear height

PREPARATION [WITH ELECTRONIC LOCKING DIFFERENTIAL]

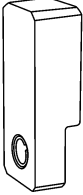
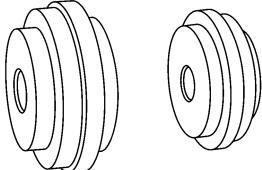
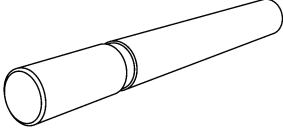
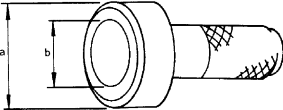
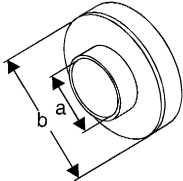
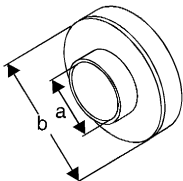
Tool number (Kent-Moore No.) Tool name	Description	A
— (D-115-2) Scooter block <div style="text-align: center;">  <p>SDIA2604E</p> </div>	Adjusting pinion gear height	B
— (8541A-1) Arbor disc <div style="text-align: center;">  <p>SDIA2605E</p> </div>	Adjusting pinion gear height	C
— (D-115-3) Arbor <div style="text-align: center;">  <p>SDIA2606E</p> </div>	Adjusting pinion gear height	RFD
ST01500001 (—) Drift <div style="text-align: center;">  <p>ZZA0811D</p> </div>	Installing drive pinion rear bearing outer race a: 89mm (3.50 in) dia. b: 79 mm (3.11 in) dia.	E
ST30022000 (—) Drift <div style="text-align: center;">  <p>NT660</p> </div>	Installing drive pinion rear bearing outer race a: 46 mm (1.81 in) dia. b: 110 mm (4.33 in) dia.	F
ST33022000 (—) Drift <div style="text-align: center;">  <p>NT660</p> </div>	Installing drive pinion front bearing outer race a: 49 mm (1.92 in) dia. b: 67 mm (2.63 in) dia.	G
		H
		I
		J
		K
		L
		M

PREPARATION [WITH ELECTRONIC LOCKING DIFFERENTIAL]

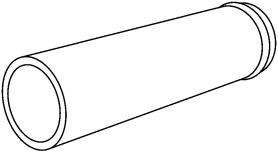
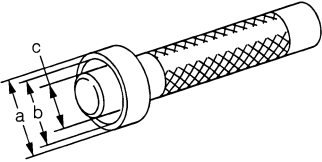
Tool number (Kent-Moore No.) Tool name	Description
<p style="text-align: center;">— (C-4040) Installer</p>  <p style="text-align: right; margin-right: 50px;">SDIA2607E</p>	<p>Installing drive pinion rear bearing inner race</p>
<p>KV38100300 (J-25523) Drift</p>  <p style="text-align: right; margin-right: 50px;">ZZA1046D</p>	<p>Installing side bearing inner race a: 54 mm (2.13 in) dia. b: 46 mm (1.81 in) dia. c: 32mm (1.26 in) dia.</p>

Commercial Service Tools

EDS003NX

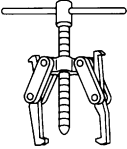
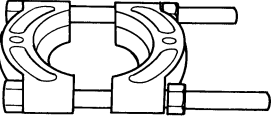
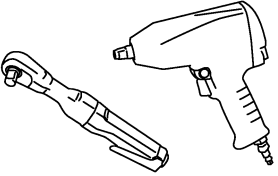
Tool name	Description
<p>Puller</p>  <p style="text-align: right; margin-right: 50px;">NT077</p>	<p>Removing companion flange and side bearing inner race</p>
<p>Puller</p>  <p style="text-align: right; margin-right: 50px;">ZZB0823D</p>	<p>Removing side bearing inner race</p>
<p>Power tool</p>  <p style="text-align: right; margin-right: 50px;">PBIC0190E</p>	<p>Loosening bolts and nuts</p>

NOISE, VIBRATION AND HARSHNESS (NVH) TROUBLESHOOTING [WITH ELECTRONIC LOCKING DIFFERENTIAL]

NOISE, VIBRATION AND HARSHNESS (NVH) TROUBLESHOOTING

PF0:0003

NVH Troubleshooting Chart

EDS003NY

Use the chart below to help you find the cause of the symptom. If necessary, repair or replace these parts.

Symptom		Possible cause and SUSPECTED PARTS													Reference page
Noise		Gear tooth rough	Gear contact improper	Tooth surfaces worn	Backlash incorrect	Companion flange excessive runout	Gear oil improper	PROPELLER SHAFT	AXLE AND SUSPENSION	TIRES	ROAD WHEEL	AXLE SHAFT	BRAKES	STEERING	
		x	x	x	x	x	x	x	x	x	x	x	x	x	—
															RFD-90, "Tooth Contact"
															—
															RFD-91, "Backlash"
															RFD-92, "Companion Flange Runout"
															RFD-11, "Checking Final Drive Oil"
															PR-3, "NVH Troubleshooting Chart"
															RAX-4, "NVH Troubleshooting Chart", RSU-4, "NVH Troubleshooting Chart"
															WT-4, "NVH Troubleshooting Chart"
															RAX-4, "NVH Troubleshooting Chart"
															BR-5, "NVH Troubleshooting Chart"
															PS-5, "NVH Troubleshooting Chart"

x: Applicable

A
B
C
D
E
F
G
H
I
J
K
L
M

RFD

DIFFERENTIAL GEAR OIL [WITH ELECTRONIC LOCKING DIFFERENTIAL]

DIFFERENTIAL GEAR OIL

PPF:KLD30

Changing Differential Gear Oil

EDS003NZ

Refer to [RFD-11, "Changing Final Drive Oil"](#) .

FILLING

Refer to [RFD-11, "Checking Final Drive Oil"](#) .

Checking Differential Gear Oil

EDS00300

Refer to [RFD-11, "Checking Final Drive Oil"](#) .

DIFFERENTIAL LOCK SYSTEM [WITH ELECTRONIC LOCKING DIFFERENTIAL]

DIFFERENTIAL LOCK SYSTEM

PFP:28496

Cross-sectional View

EDS00301

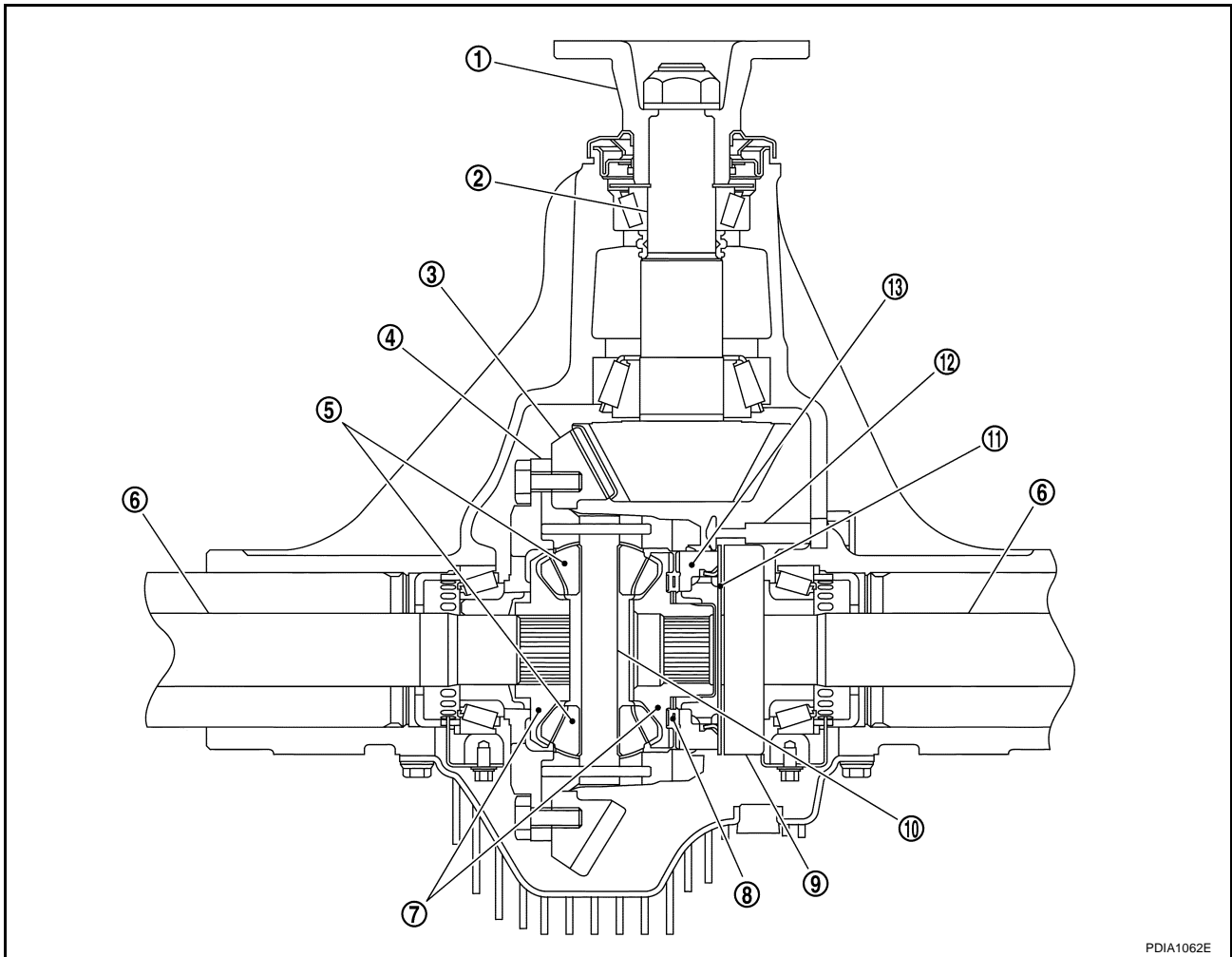

- | | | |
|-----------------------|---------------------|---------------------------------------|
| 1. Companion flange | 2. Drive pinion | 3. Drive gear |
| 4. Differential case | 5. Pinion mate gear | 6. Axle shaft |
| 7. Side gear | 8. Spring | 9. Differential lock solenoid |
| 10. Pinion mate shaft | 11. Pressure plate | 12. Differential lock position switch |
| 13. Cam ring | | |

PDIA1062E

A
B
C
RFD
E
F
G
H
I
J
K
L
M

DIFFERENTIAL LOCK SYSTEM [WITH ELECTRONIC LOCKING DIFFERENTIAL]

Differential Lock Operation

EDS00302

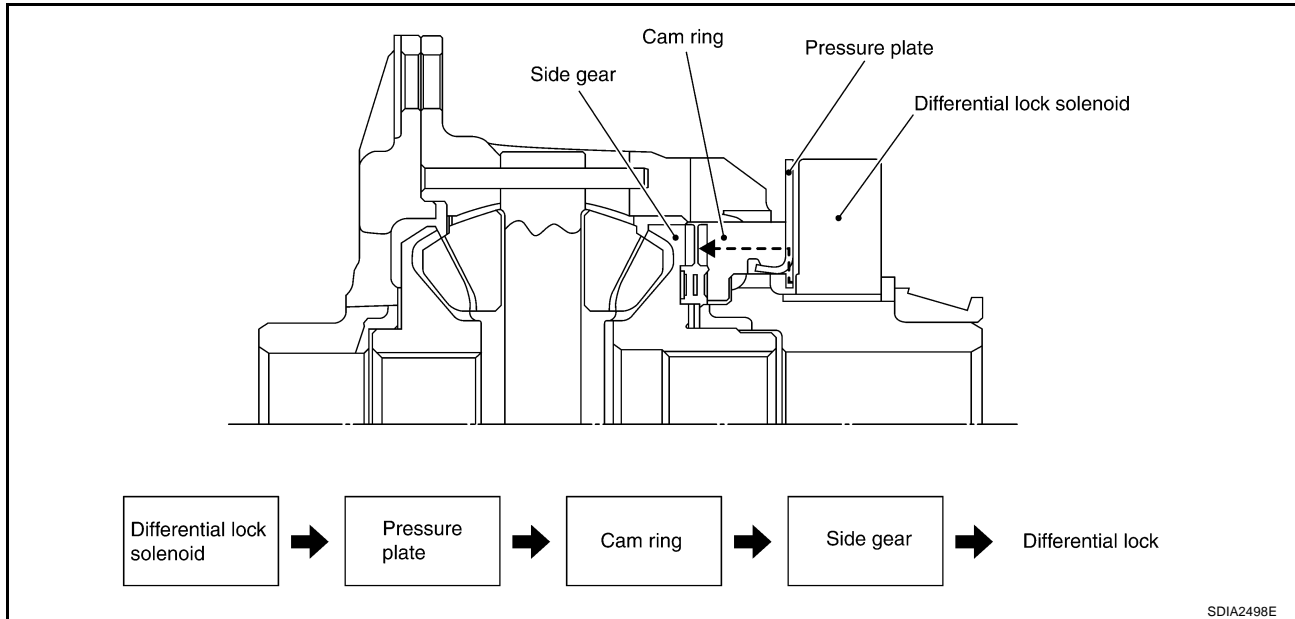

SDIA2498E

1. Differential lock solenoid operates pressure plate.
2. Pressure plate presses cam ring.
3. Engage cam ring and side gear, and then differential is locked.

System Description

EDS00303

DIFFERENTIAL LOCK SOLENOID

It is operated by signal from differential lock control unit, and it operates pressure plate so as to switch lock/unlock.

DIFFERENTIAL LOCK POSITION SWITCH

It detects that differential is in lock or unlock by pressure plate position, and sends it to differential lock control unit.

DIFFERENTIAL LOCK CONTROL UNIT

- Differential lock control unit controls differential lock solenoid by input signals of each sensor and each switch.
- As a fail-safe function, differential lock disengages, if malfunction is detected in differential lock system.
- Self-diagnosis can be done with CONSULT-II.

DIFFERENTIAL LOCK MODE SWITCH

Able to select differential lock and unlock.

DIFF LOCK INDICATOR LAMP

The following is the indications of indicator lamp.

Condition	DIFF LOCK indicator lamp
Differential lock/unlock	ON/OFF
Differential lock standby condition	Flashing: 1 time/2 seconds
Differential lock system malfunction	OFF (Even if differential lock mode switch is turned ON)
Lamp check	Turns ON when ignition switch is turned ON. Turns OFF after engine start.

NOTE:

Differential lock standby condition is the condition that differential lock mode switch is ON and differential is unlocked.

DIFFERENTIAL LOCK SYSTEM [WITH ELECTRONIC LOCKING DIFFERENTIAL]

System Diagram

EDS00304

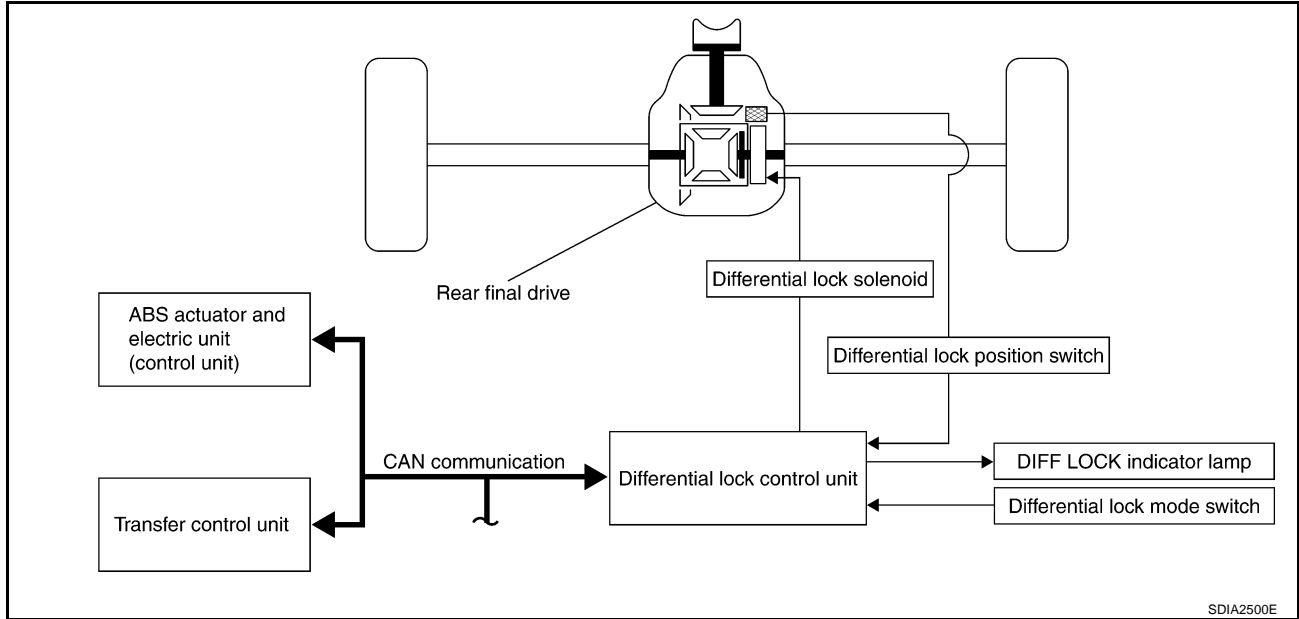

COMPONENTS FUNCTION DESCRIPTION

Component parts	Function
Differential lock control unit	<ul style="list-style-type: none"> Controls differential lock solenoid and switches differential lock/unlock. As a fail-safe function, differential lock disengages, if malfunction is detected in differential lock system.
Differential lock solenoid	Controls pressure plate by current from differential lock control unit.
Differential lock position switch	Detects that differential is lock or unlock condition.
Differential lock mode switch	Able to select differential lock or unlock.
DIFF LOCK indicator lamp	Illuminates that differential is in lock or lock standby condition.
ABS actuator and electric unit (control unit)	Transmits the following signals via CAN communication to differential lock control unit. <ul style="list-style-type: none"> Vehicle speed signal VDC operation signal
Transfer control unit	Transmits the following signal via CAN communication to differential lock control unit. <ul style="list-style-type: none"> 4WD shift switch signal

CAN Communication SYSTEM DESCRIPTION

EDS00305

Refer to [LAN-7, "CAN COMMUNICATION"](#) .

TROUBLE DIAGNOSIS [WITH ELECTRONIC LOCKING DIFFERENTIAL]

TROUBLE DIAGNOSIS

PF0:00004

Fail-safe Function

EDS00306

If any malfunction occurs in differential lock system, and control unit detects the malfunction, DIFF LOCK indicator lamp on combination meter does not turn ON to indicate system malfunction. Differential lock control unit turns differential lock solenoid OFF.

How to Perform Trouble Diagnosis

EDS00307

BASIC CONCEPT

- To perform trouble diagnosis, it is the most important to have understanding about vehicle systems (control and mechanism) thoroughly.
- It is also important to clarify customer complaints before inspection.

First of all, reproduce symptoms, and understand them fully. Ask customer about his/her complaints carefully. In some cases, it will be necessary to check symptoms by driving vehicle with customer.

CAUTION:

Customers are not professional. It is dangerous to make an easy guess like "maybe the customer means that...," or "maybe the customer mentions this symptom".

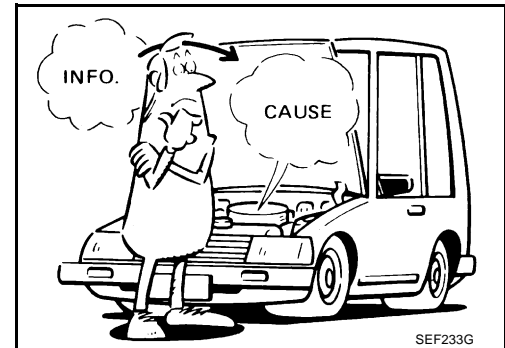

- It is essential to check symptoms right from the beginning in order to repair malfunctions completely. For intermittent malfunctions, reproduce symptoms based on interview with customer and past examples. Do not perform inspection on ad hoc basis. Most intermittent malfunctions are caused by poor contacts. In this case, it will be effective to shake suspected harness or connector by hand. When repairing without any symptom diagnosis, you cannot judge if malfunctions have actually been eliminated.
- After completing diagnosis, always erase diagnostic memory. Refer to [RFD-56, "How to Erase Self-diagnostic Results"](#).
- For intermittent malfunctions, move harness or harness connector by hand. Then check for poor contact or reproduced open circuit.

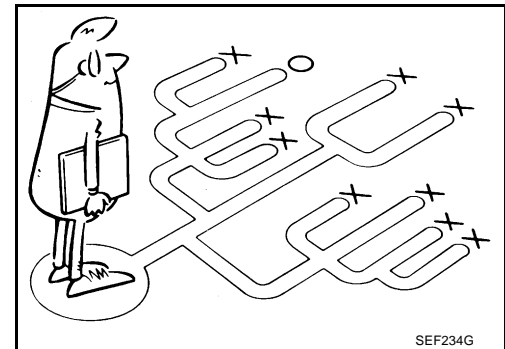

TROUBLE DIAGNOSIS [WITH ELECTRONIC LOCKING DIFFERENTIAL]

Location of Electrical Parts

EDS00308

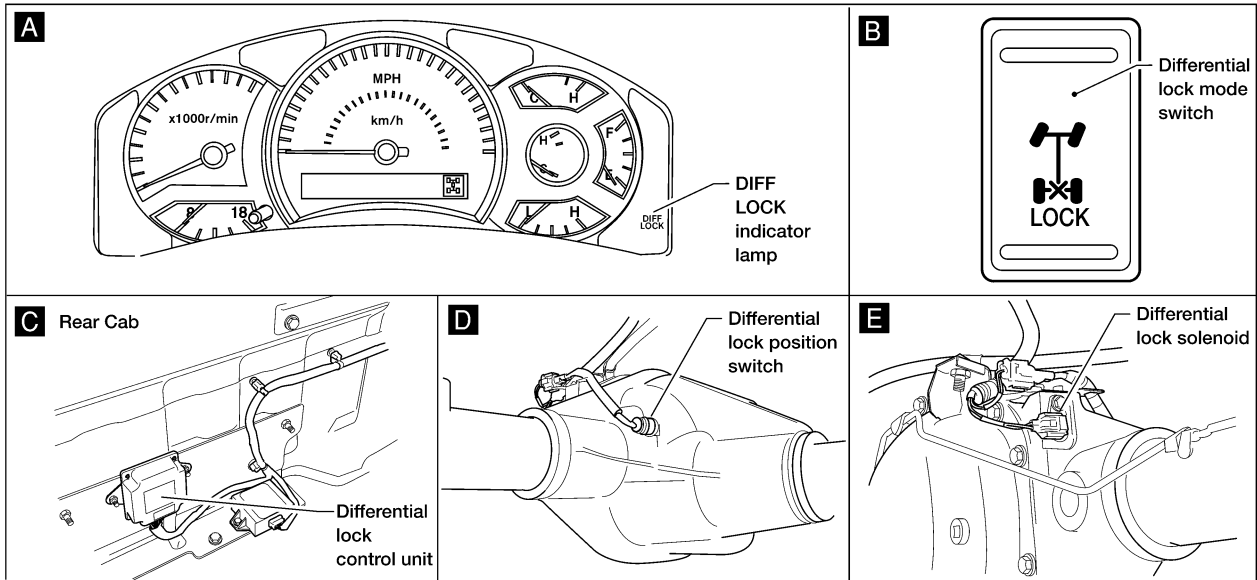
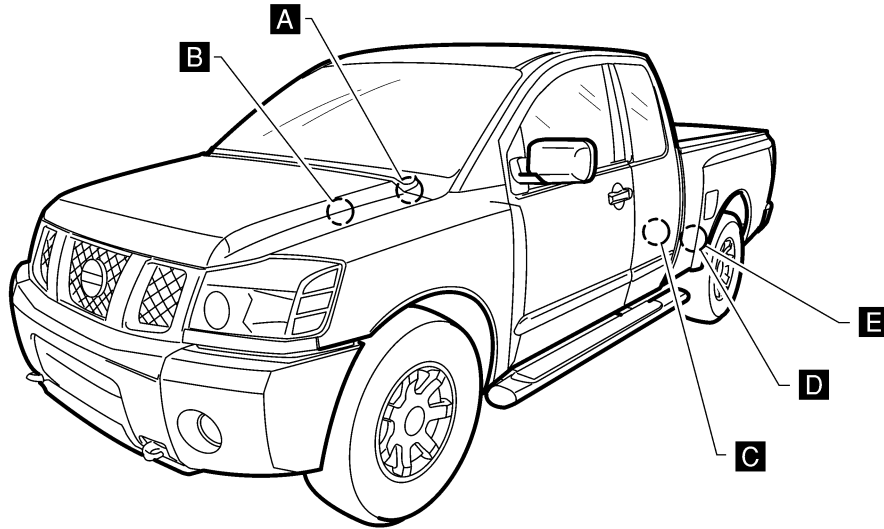

BDIA0015E

A
B
C
RFD
E
F
G
H
I
J
K
L
M

TROUBLE DIAGNOSIS [WITH ELECTRONIC LOCKING DIFFERENTIAL]

Wiring Diagram — DIFLOC —

EDS00309

RFD-DIFLOC-01

— : DATA LINE

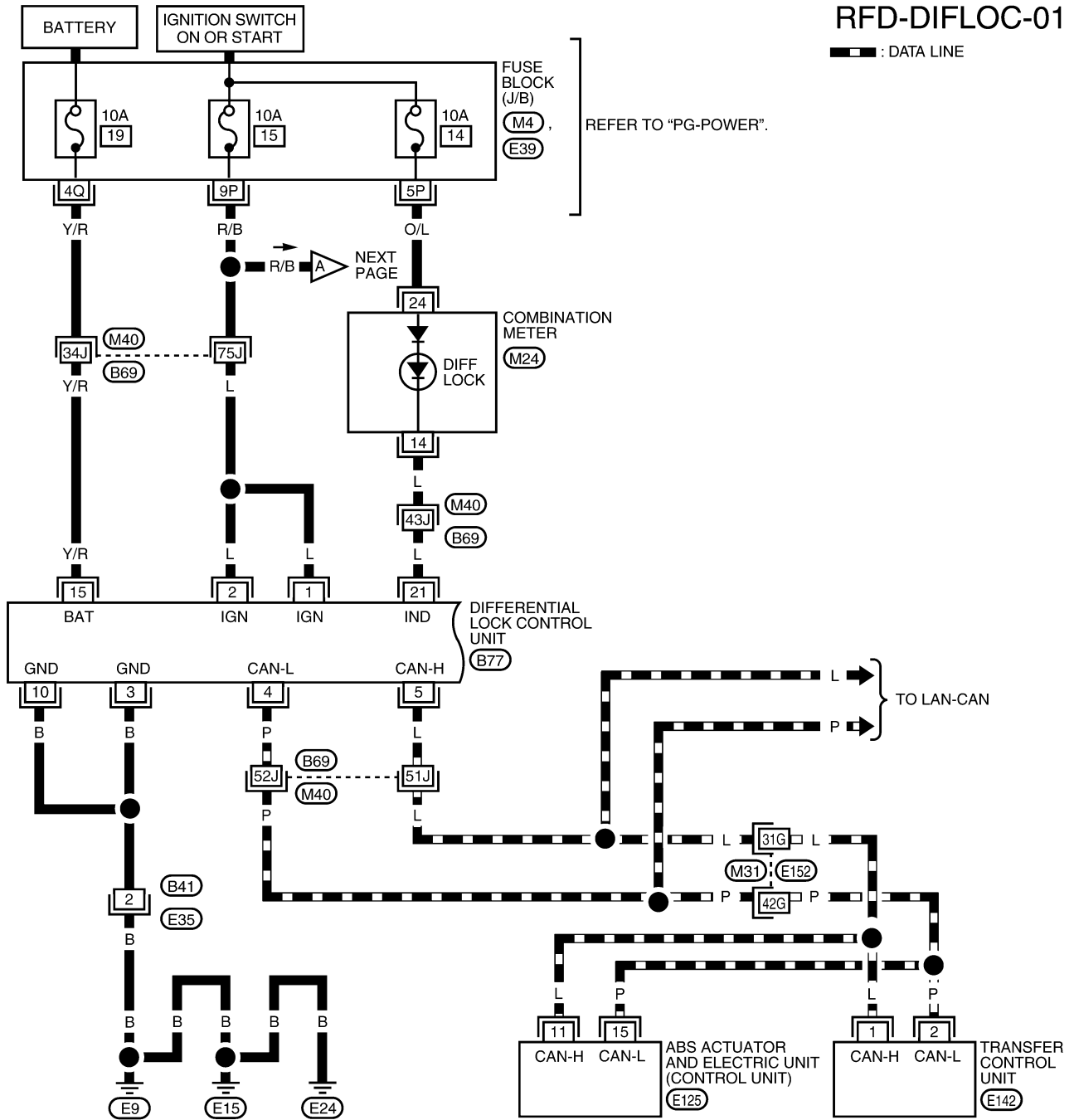

REFER TO "PG-POWER".

NEXT PAGE

TO LAN-CAN

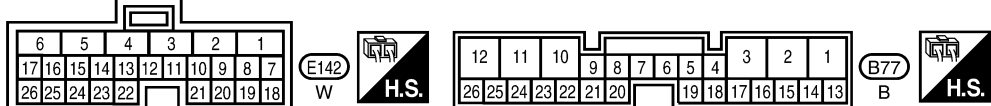
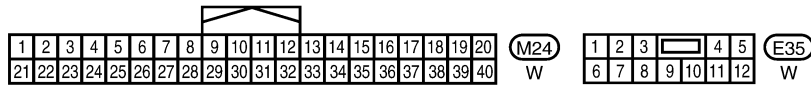
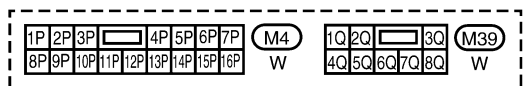

REFER TO THE FOLLOWING.
 (M31), (M40) - SUPER MULTIPLE JUNCTION (SMJ)
 (E125) - ELECTRICAL UNITS

TROUBLE DIAGNOSIS [WITH ELECTRONIC LOCKING DIFFERENTIAL]

RFD-DIFLOC-02

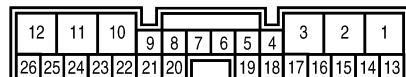
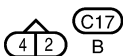
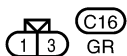
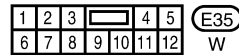
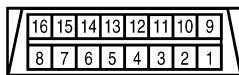
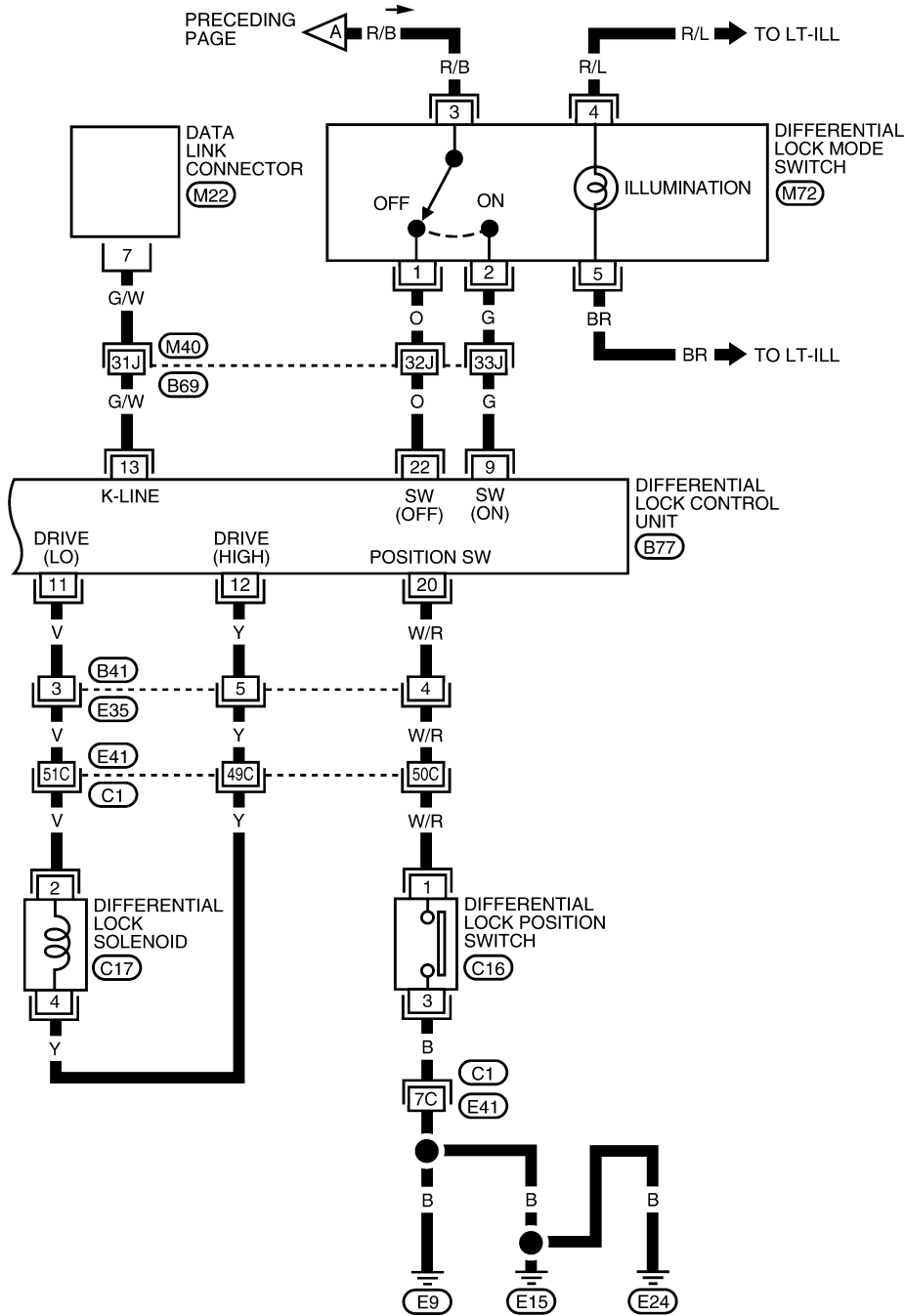

REFER TO THE FOLLOWING.
(M40), **(C1)** - SUPER
 MULTIPLE JUNCTION (SMJ)

BDWA0053E

TROUBLE DIAGNOSIS

[WITH ELECTRONIC LOCKING DIFFERENTIAL]

Trouble Diagnosis Chart for Symptoms

EDS0030A

If DIFF LOCK indicator lamp does not turn ON after engine start, perform self-diagnosis. Refer to [RFD-55, "SELF-DIAG RESULTS MODE"](#).

Symptom	Condition	Check item	Reference page
DIFF LOCK indicator lamp does not turn ON. (DIFF LOCK indicator lamp check)	Ignition switch: ON	CAN communication line	RFD-74
		Power supply and ground for differential lock control unit	
		Combination meter	
DIFF LOCK indicator lamp does not change.	<ul style="list-style-type: none"> ● Engine running ● Differential lock mode switch: ON 	Combination meter	RFD-77
		Differential lock mode switch	
		CAN communication line	
DIFF LOCK indicator lamp sometimes flashes.	<ul style="list-style-type: none"> ● Engine running ● Differential lock mode switch: ON 	Combination meter	RFD-78
		Differential lock mode switch	
		Differential lock position switch	
		Differential inner parts	

Differential Lock Control Unit Input/Output Signal Reference Values

EDS0030B

DIFFERENTIAL LOCK CONTROL UNIT INSPECTION TABLE

Specifications with CONSULT-II

Monitor item [Unit]	Content	Condition	Display value
BATTERY VOLT [V]	Power supply voltage for differential lock control unit	Ignition switch: ON	Battery voltage
4WD MODE [2H/4H/4Lo]	Condition of 4WD shift switch	4WD shift switch (Engine running)	2H
			4H
			4Lo
VHCL S/SEN-R [km/h] or [mph]	Wheel speed (Rear wheel right)	Vehicle stopped	0 km/h (0 mph)
		Vehicle running CAUTION: Check air pressure of tire under standard condition.	Approximately equal to the indication on speedometer (Inside of ±10%)
VHCL S/SEN-L [km/h] or [mph]	Wheel speed (Rear wheel left)	Vehicle stopped	0 km/h (0 mph)
		Vehicle running CAUTION: Check air pressure of tire under standard condition.	Approximately equal to the indication on speedometer (Inside of ±10%)
VHCL S/SEN-RL [km/h] or [mph]	Wheel speed (Average value of rear wheel right and left)	Vehicle stopped	0 km/h (0 mph)
		Vehicle running CAUTION: Check air pressure of tire under standard condition.	Approximately equal to the indication on speedometer (Inside of ±10%)
D-LOCK SW SIG [ON/OFF]	Condition of differential lock mode switch	Differential lock mode switch: ON	ON
		Differential lock mode switch: OFF	OFF
D-LOCK SIG [ON/OFF]	Control status of differential lock	<ul style="list-style-type: none"> ● Vehicle stopped ● Engine running ● VDC OFF switch: ON ● 4WD shift switch: 4LO 	Differential lock mode switch: ON ON
			Differential lock mode switch: OFF OFF

TROUBLE DIAGNOSIS [WITH ELECTRONIC LOCKING DIFFERENTIAL]

Monitor item [Unit]	Content	Condition		Display value
RELAY ON [ON/OFF]	Operating condition of differential lock solenoid relay (integrated in differential lock control unit)	<ul style="list-style-type: none"> ● Vehicle stopped ● Engine running ● VDC OFF switch: ON ● 4WD shift switch: 4LO 	Differential lock mode switch: ON	ON
			Differential lock mode switch: OFF	OFF
RELAY MTR [ON/OFF]	Control status of differential lock solenoid relay (integrated in differential lock control unit)	<ul style="list-style-type: none"> ● Vehicle stopped ● Engine running ● VDC OFF switch: ON ● 4WD shift switch: 4LO 	Differential lock mode switch: ON	ON
			Differential lock mode switch: OFF	OFF
SOL MTR [ON/OFF]	Control status of differential lock solenoid	<ul style="list-style-type: none"> ● Vehicle stopped ● Engine running ● VDC OFF switch: ON ● 4WD shift switch: 4LO 	Differential lock mode switch: ON	ON
			Differential lock mode switch: OFF	OFF
IND MTR [ON/OFF]	Control status of DIFF LOCK indicator lamp	DIFF LOCK indicator lamp: ON		ON
		DIFF LOCK indicator lamp: OFF		OFF
D-LOCK POS SW [ON/OFF]	Condition of differential lock position switch	<ul style="list-style-type: none"> ● Vehicle stopped ● Engine running ● VDC OFF switch: ON ● 4WD shift switch: 4LO 	Differential lock mode switch: ON (DIFF LOCK indicator lamp: ON)	ON
			Differential lock mode switch: OFF (DIFF LOCK indicator lamp: OFF)	OFF

Specifications Between Differential Lock Control Unit Terminals

DIFFERENTIAL LOCK CONTROL UNIT TERMINAL CONNECTOR LAYOUT

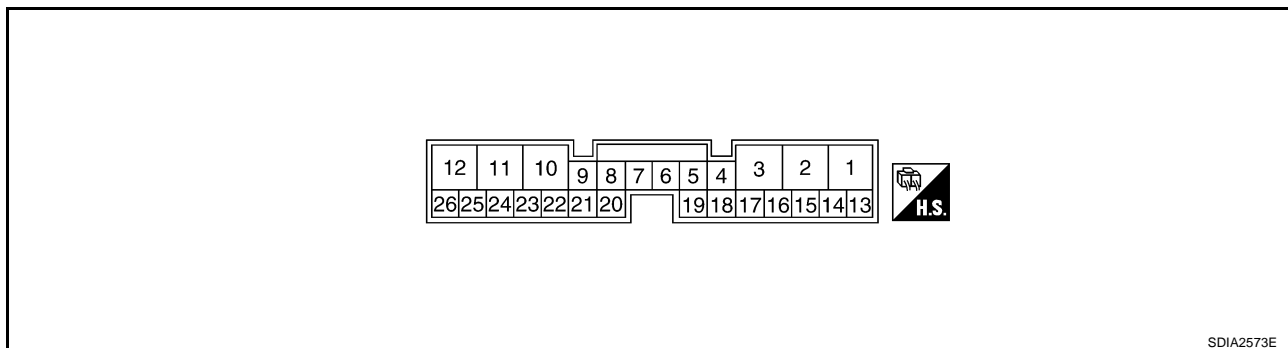

Data are reference value and are measured between each terminal and ground.

Terminal	Wire color	Item	Condition	Data (Approx.)	
1	L	Power supply	Ignition switch: ON	Battery voltage	
			Ignition switch: OFF	0V	
2	L	Power supply	Ignition switch: ON	Battery voltage	
			Ignition switch: OFF	0V	
3	B	Ground	Always	0V	
4	P	CAN-L	-	-	
5	L	CAN-H	-	-	
9	G	Differential lock mode switch (ON)	Ignition switch: ON	Differential lock mode switch: ON	Battery voltage
				Differential lock mode switch: OFF	0V
10	B	Ground	Always	0V	

TROUBLE DIAGNOSIS

[WITH ELECTRONIC LOCKING DIFFERENTIAL]

Terminal	Wire color	Item	Condition		Data (Approx.)
11	V	Differential lock solenoid (-)	<ul style="list-style-type: none"> ● Vehicle stopped ● Engine running ● VDC OFF switch: ON ● 4WD shift switch: 4LO 	Differential lock mode switch: ON	0V
				Differential lock mode switch: OFF	Battery voltage
12	Y	Differential lock solenoid (+)	<ul style="list-style-type: none"> ● Vehicle stopped ● Engine running ● VDC OFF switch: ON ● 4WD shift switch: 4LO 	Differential lock mode switch: ON	0V
				Differential lock mode switch: OFF	Battery voltage
13	G/W	K-LINE (CONSULT-II signal)	-		-
15	Y/R	Power supply (Memory back-up)	Ignition switch: ON		Battery voltage
			Ignition switch: OFF		Battery voltage
20	W/R	Differential lock position switch	<ul style="list-style-type: none"> ● Vehicle stopped ● Engine running ● VDC OFF switch: ON ● 4WD shift switch: 4LO 	Differential lock mode switch: ON (DIFF LOCK indicator lamp: ON)	0V
				Differential lock mode switch: OFF (DIFF LOCK indicator lamp: OFF)	Battery voltage
21	L	DIFF LOCK indicator lamp	Ignition switch: ON	DIFF LOCK indicator lamp: ON	0V
				DIFF LOCK indicator lamp: OFF	Battery voltage
22	O	Differential lock mode switch (OFF)	Ignition switch: ON	Differential lock mode switch: ON	0V
				Differential lock mode switch: OFF	Battery voltage

CAUTION:

When using a circuit tester to measure voltage for inspection, be sure not to extend forcibly any connector terminals.

CONSULT-II Function (DIFF LOCK)

EDS0030C

CONSULT-II can display each diagnostic item using the diagnostic test modes shown following.

DIFF LOCK Diagnostic test mode	Function	Reference page
SELF-DIAGNOSTIC RESULTS	● Displays diff lock self-diagnostic results.	RFD-55
DATA MONITOR	● Displays diff lock input/output data in the time.	RFD-57
CAN DIAG SUPPORT MNTR	● The results of transmit/receive diagnosis of CAN communication can be read.	—

CONSULT-II SETTING PROCEDURE

CAUTION:

If CONSULT-II is used with no connection of CONSULT-II CONVERTER, malfunctions might be detected in self-diagnosis depending on control unit which carries out CAN communication.

- For details, refer to the separate "CONSULT-II Operations Manual".
1. Turn ignition switch "OFF".
 2. Connect CONSULT-II and CONSULT-II CONVERTER to data link connector on vehicle.
 3. Turn ignition switch "ON".

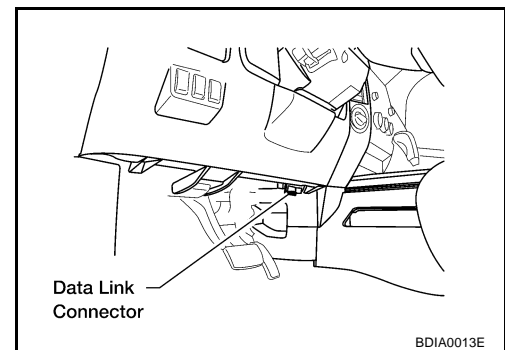

TROUBLE DIAGNOSIS [WITH ELECTRONIC LOCKING DIFFERENTIAL]

4. Touch "START (NISSAN BASED VHCL)".

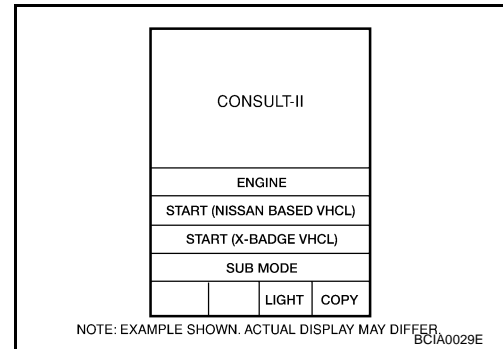

5. Touch "DIFF LOCK".
If "DIFF LOCK" is not indicated, go to [GI-39, "CONSULT-II Data Link Connector \(DLC\) Circuit"](#) .
6. Perform each diagnostic test mode according to each service procedure.

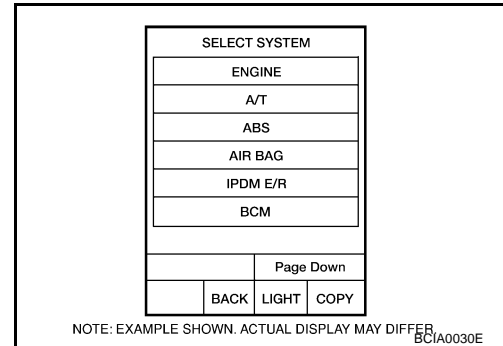

SELF-DIAG RESULTS MODE

Operation Procedure

- Perform "CONSULT-II SETTING PROCEDURE". Refer to [RFD-54, "CONSULT-II SETTING PROCEDURE"](#) .
- With engine at idle, touch "SELF-DIAG RESULTS".
Display shows malfunction experienced since the last erasing operation.

NOTE:

- The details for "TIME" are as follow:
 - "0": Error currently detected with differential lock control unit.
 - Except for "0": Error detected in the past and memorized with differential lock control unit.
Detects frequency of driving after DTC occurs (frequency of turning ignition switch "ON/OFF").

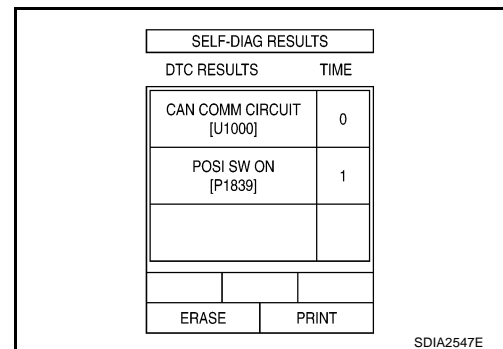

Display Item List

Items (CONSULT-II screen terms)	Diagnostic item is detected when...	Check item
INITIAL START [P1833]	<ul style="list-style-type: none"> Due to removal of battery which cuts off power supply to differential control unit, self-diagnosis memory function is suspended. 	RFD-58, "Power Supply Circuit For Differential Lock Control Unit"
CONTROL UNIT 1 [P1834]	<ul style="list-style-type: none"> Malfunction is detected in the memory (RAM) system of differential lock control unit. 	RFD-60, "Differential Lock Control Unit"
CONTROL UNIT 2 [P1835]	<ul style="list-style-type: none"> Malfunction is detected in the memory (ROM) system of differential lock control unit. 	RFD-60, "Differential Lock Control Unit"
CONTROL UNIT 3 [P1836]	<ul style="list-style-type: none"> Malfunction is detected in the memory (EEPROM) system of differential lock control unit. 	RFD-60, "Differential Lock Control Unit"
CONTROL UNIT 4 [P1837]	<ul style="list-style-type: none"> AD converter system of differential lock control unit is malfunctioning. 	RFD-60, "Differential Lock Control Unit"
ON SW [P1838]	<ul style="list-style-type: none"> More than two switch inputs are simultaneously detected due to short circuit of differential lock mode switch. 	RFD-60, "Differential Lock Mode Switch"

TROUBLE DIAGNOSIS [WITH ELECTRONIC LOCKING DIFFERENTIAL]

Items (CONSULT-II screen terms)	Diagnostic item is detected when...	Check item
POSI SW ON [P1839]	<ul style="list-style-type: none"> When differential lock position switch is ON, rotation difference occurs in wheel speed (rear wheel right and left). 	RFD-64, "Differential Lock Position Switch"
RELAY [P1844]	<ul style="list-style-type: none"> Differential lock control unit detects as irregular by comparing target value with monitor value. 	RFD-67, "Differential Lock Solenoid Relay" , RFD-68, "Differential Lock Solenoid"
SOL CIRCUIT [P1847]	<ul style="list-style-type: none"> Malfunction is detected in differential lock control unit internal circuit. 	RFD-68, "Differential Lock Solenoid"
SOL DISCONNECT [P1848]	<ul style="list-style-type: none"> Differential lock solenoid internal circuit or harness is open. Differential lock solenoid relay does not switch to ON position. 	RFD-68, "Differential Lock Solenoid"
SOL SHORT [P1849]	<ul style="list-style-type: none"> Differential lock solenoid internal circuit or harness is shorted. 	RFD-68, "Differential Lock Solenoid"
SOL CURRENT [P1850]	<ul style="list-style-type: none"> Differential lock solenoid relay does not switch to OFF position. 	RFD-68, "Differential Lock Solenoid"
ABS SYSTEM [C1203]	<ul style="list-style-type: none"> Malfunction related to wheel sensor has been detected by ABS actuator and electric unit (control unit). 	RFD-72, "ABS System"
CAN COMM CIRCUIT [U1000]	<ul style="list-style-type: none"> Malfunction has been detected from CAN communication line. 	RFD-73, "CAN Communication Line"
NO DTC IS DETECTED. FURTHER TESTING MAY BE REQUIRED.	<ul style="list-style-type: none"> No NG item has been detected. 	—

CAUTION:

If "CAN COMM CIRCUIT [U1000]" is displayed with other DTCs, first perform the trouble diagnosis for CAN communication line.

How to Erase Self-diagnostic Results

1. Perform applicably inspection of malfunctioning item and then repair or replace.
2. Start engine and select "SELF-DIAG RESULTS" mode for "DIFF LOCK" with CONSULT-II.
3. Touch "ERASE" on CONSULT-II screen to erase DTC memory.

CAUTION:

If memory cannot be erased, perform applicably diagnosis.

TROUBLE DIAGNOSIS

[WITH ELECTRONIC LOCKING DIFFERENTIAL]

DATA MONITOR MODE

Operation Procedure

1. Perform "CONSULT-II SETTING PROCEDURE". Refer to [RFD-54, "CONSULT-II SETTING PROCEDURE"](#).
2. Touch "DATA MONITOR".
3. Select from "SELECT MONITOR ITEM", screen of data monitor mode is displayed.

NOTE:

**When malfunction is detected, CONSULT-II performs REAL-TIME DIAGNOSIS.
Also, any malfunction detected while in this mode will be displayed at real time.**

Display Item List

×: Standard -: Not applicable

Monitor item (Unit)	SELECT MONITOR ITEM			Remarks
	ECU INPUT SIGNALS	MAIN SIGNALS	SELECTION FROM MENU	
BATTERY VOLT [V]	×	×	×	Power supply voltage for differential lock control unit.
4WD MODE [2H/4H/4Lo]	×	×	×	4WD shift switch signal status via CAN communication line is displayed.
VHCL S/SEN-R [km/h] or [mph]	×	-	×	Wheel speed calculated by rear wheel sensor right signal is displayed.
VHCL S/SEN-L [km/h] or [mph]	×	-	×	Wheel speed calculated by rear wheel sensor left signal is displayed.
VHCL S/SEN-RL [km/h] or [mph]	×	×	×	Average value between wheel speed calculated by rear wheel sensor right signal and rear wheel sensor left signal is displayed.
D-LOCK SW SIG [ON/OFF]	×	×	×	Condition of differential lock mode switch is displayed.
D-LOCK SIG [ON/OFF]	×	×	×	Control status of differential lock is displayed.
RELAY ON [ON/OFF]	×	×	×	Operating condition of differential lock solenoid relay is displayed (integrated in differential lock control unit).
RELAY MTR [ON/OFF]	×	×	×	Control status of differential lock solenoid relay is displayed (integrated in differential lock control unit).
SOL MTR [ON/OFF]	×	×	×	Control status of differential lock solenoid is displayed.
IND MTR [ON/OFF]	×	×	×	Control status of DIFF LOCK indicator lamp is displayed.
D-LOCK POS SW [ON/OFF]	×	×	×	Condition of differential lock position switch is displayed.
Voltage [V]	-	-	×	The value measured by the voltage probe is displayed.
Frequency [Hz]	-	-	×	The value measured by the pulse probe is displayed.
DUTY-HI (high) [%]	-	-	×	
DUTY-LOW (low) [%]	-	-	×	
PLS WIDTH-HI [msec]	-	-	×	
PLS WIDTH-LOW [msec]	-	-	×	

TROUBLE DIAGNOSIS FOR SYSTEM
[WITH ELECTRONIC LOCKING DIFFERENTIAL]

TROUBLE DIAGNOSIS FOR SYSTEM

PFP:00000

Power Supply Circuit For Differential Lock Control Unit
CONSULT-II REFERENCE VALUE IN DATA MONITOR MODE

EDS0030D

Data are reference value.

Monitor item [Unit]	Content	Condition	Display value
BATTERY VOLT [V]	Power supply voltage for differential lock control unit	Ignition switch: ON	Battery voltage

DIFFERENTIAL LOCK CONTROL UNIT TERMINALS AND REFERENCE VALUE

Data are reference value and are measured between each terminal and ground.

Terminal	Wire color	Item	Condition	Data (Approx.)
1	L	Power supply	Ignition switch: ON	Battery voltage
			Ignition switch: OFF	0V
2	L	Power supply	Ignition switch: ON	Battery voltage
			Ignition switch: OFF	0V
3	B	Ground	Always	0V
10	B	Ground	Always	0V
15	Y/R	Power supply (Memory back-up)	Ignition switch: ON	Battery voltage
			Ignition switch: OFF	Battery voltage

CAUTION:

When using a circuit tester to measure voltage for inspection, be sure not to extend forcibly any connector terminals.

TROUBLE DIAGNOSIS FOR SYSTEM [WITH ELECTRONIC LOCKING DIFFERENTIAL]

DIAGNOSTIC PROCEDURE

1. CHECK POWER SUPPLY

1. Turn ignition switch "OFF".
2. Disconnect differential lock control unit harness connector.
3. Check voltage between differential lock control unit harness connector terminals and ground.

Connector	Terminal	Voltage (Approx.)
B77	1 - Ground	0V
	2 - Ground	0V
	15 - Ground	Battery voltage

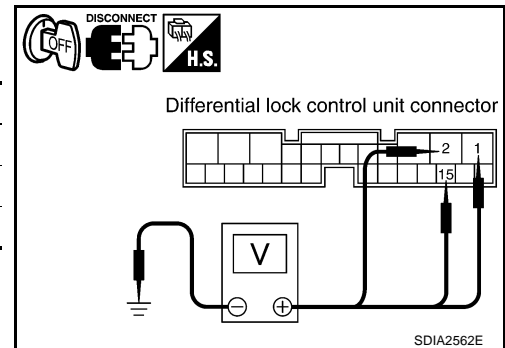

4. Turn ignition switch "ON". (Do not start engine.)
5. Check voltage between differential lock control unit harness connector terminals and ground.

Connector	Terminal	Voltage (Approx.)
B77	1 - Ground	Battery voltage
	2 - Ground	
	15 - Ground	

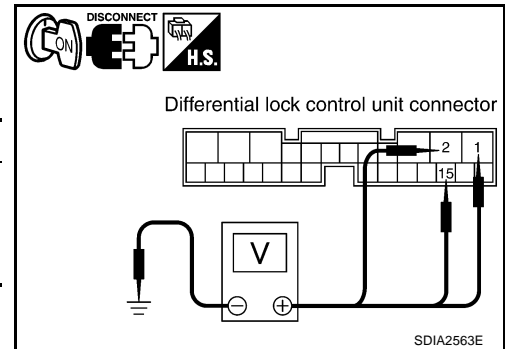

OK or NG

OK >> GO TO 2.

NG >> Check the following. If any items are damaged, repair or replace damaged parts.

- 10A fuse [No. 15 or 19, located in fuse block (J/B)]
- Harness for short or open between battery and differential lock control unit harness connector terminal 15
- Harness for short or open between ignition switch and differential lock control unit harness connector terminals 1 and 2
- Battery and ignition switch. Refer to [PG-4, "POWER SUPPLY ROUTING CIRCUIT"](#).

2. CHECK GROUND CIRCUIT

1. Turn ignition switch "OFF".
2. Disconnect differential lock control unit harness connector.
3. Check continuity between differential lock control unit harness connector B77 terminals 3, 10 and ground.

Continuity should exist.

Also check harness for short to ground and short to power.

OK or NG

OK >> GO TO 3.

NG >> Repair open circuit or short to ground or short to power in harness or connectors.

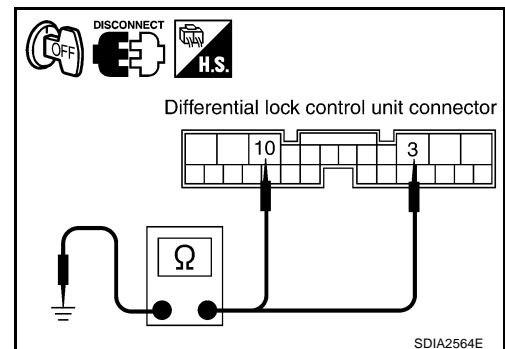

TROUBLE DIAGNOSIS FOR SYSTEM [WITH ELECTRONIC LOCKING DIFFERENTIAL]

3. CHECK DIFFERENTIAL LOCK CONTROL UNIT

Check differential lock control unit input/output signal. Refer to [RFD-52, "Differential Lock Control Unit Input/Output Signal Reference Values"](#) .

OK or NG

- OK >> GO TO 4.
- NG >> Check differential lock control unit pin terminals for damage or loose connection with harness connector. If any items are damaged, repair or replace damaged parts.

4. CHECK DTC

Perform the self-diagnosis, after driving a vehicle for a while.

OK or NG

- OK >> **INSPECTION END**
- NG >> Replace differential lock control unit. Refer to [RFD-80, "DIFFERENTIAL LOCK CONTROL UNIT"](#)

Differential Lock Control Unit DIAGNOSTIC PROCEDURE

EDS0030E

1. PERFORM SELF-DIAGNOSIS

Ⓟ **With CONSULT-II**

1. Turn ignition switch "ON". (Do not start engine.)
2. Select "SELF-DIAG RESULTS" mode for "DIFF LOCK" with CONSULT-II.
3. Touch "ERASE".
4. Turn ignition switch "OFF" and wait at least 10 seconds.
5. Perform the self-diagnosis again.

Is the "CONTROL UNIT 1 [P1834]", "CONTROL UNIT 2 [P1835]", "CONTROL UNIT 3 [P1836]" or "CONTROL UNIT 4 [P1837]" displayed?

YES >> Replace differential lock control unit. Refer to [RFD-80, "DIFFERENTIAL LOCK CONTROL UNIT"](#)

NO >> **INSPECTION END**

Differential Lock Mode Switch CONSULT-II REFERENCE VALUE IN DATA MONITOR MODE

EDS0030F

Data are reference value.

Monitor item	Content	Condition	Display value
D-LOCK SW SIG [ON/OFF]	Condition of differential lock mode switch	Differential lock mode switch: ON	ON
		Differential lock mode switch: OFF	OFF

DIFFERENTIAL LOCK CONTROL UNIT TERMINALS AND REFERENCE VALUE

Data are reference value and are measured between each terminal and ground.

Terminal	Wire color	Item	Condition	Data (Approx.)
9	G	Differential lock mode switch (ON)	Ignition switch: ON	Differential lock mode switch: ON Battery voltage
			Ignition switch: OFF	Differential lock mode switch: OFF 0V
22	O	Differential lock mode switch (OFF)	Ignition switch: ON	Differential lock mode switch: ON 0V
			Ignition switch: OFF	Differential lock mode switch: OFF Battery voltage

CAUTION:

When using a circuit tester to measure voltage for inspection, be sure not to extend forcibly any connector terminals.

TROUBLE DIAGNOSIS FOR SYSTEM [WITH ELECTRONIC LOCKING DIFFERENTIAL]

DIAGNOSTIC PROCEDURE

1. CHECK DIFFERENTIAL LOCK MODE SWITCH SIGNAL

④ With CONSULT-II

1. Start engine.
2. Select "DATA MONITOR" mode for "DIFF LOCK" with CONSULT-II.
3. Read out ON/OFF switching action of "D-LOCK SW SIG".

Monitor item	Condition		Display value
D-LOCK SW SIG	<ul style="list-style-type: none"> ● Vehicle stopped ● Engine running 	Differential lock mode switch: ON	ON
		Differential lock mode switch: OFF	OFF

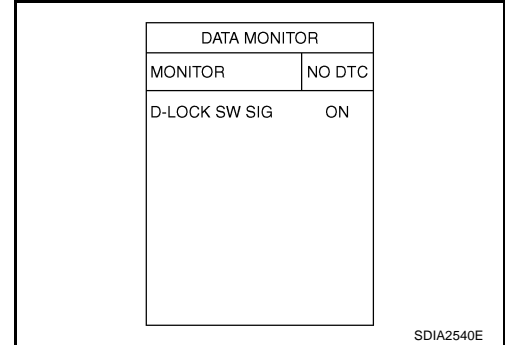

⊗ Without CONSULT-II

1. Turn ignition switch "ON".
2. Check voltage between differential lock control unit harness connector terminals and ground.

Connector	Terminal	Condition	Voltage (Approx.)
B77	9 - Ground	Differential lock mode switch: ON	Battery voltage
		Differential lock mode switch: OFF	0V
	22 - Ground	Differential lock mode switch: ON	0V
		Differential lock mode switch: OFF	Battery voltage

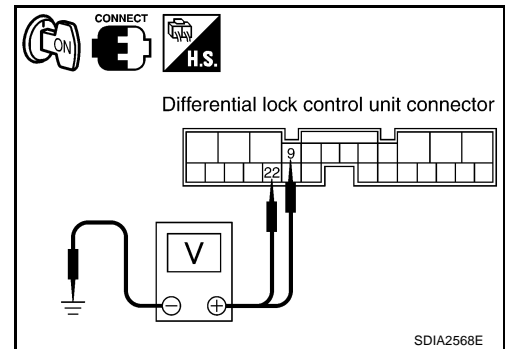

OK or NG

- OK >> GO TO 5.
NG >> GO TO 2.

TROUBLE DIAGNOSIS FOR SYSTEM [WITH ELECTRONIC LOCKING DIFFERENTIAL]

2. CHECK DIFFERENTIAL LOCK MODE SWITCH SUPPLY CIRCUIT

1. Turn ignition switch "ON".
2. Disconnect differential lock mode switch harness connector.
3. Check voltage between differential lock mode switch harness connector terminal 3 and ground.

Connector	Terminal	Voltage (Approx.)
M72	3 - Ground	Battery voltage

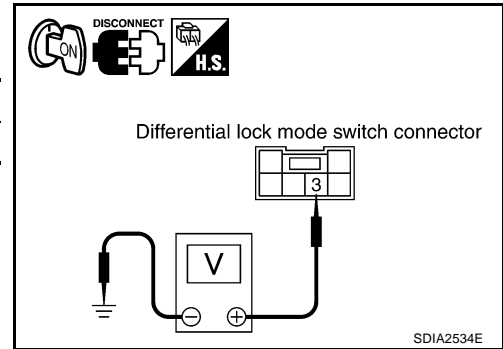

4. Turn ignition switch "OFF".
5. Check voltage between differential lock mode switch harness connector terminal 3 and ground.

Connector	Terminal	Voltage (Approx.)
M72	3 - Ground	0V

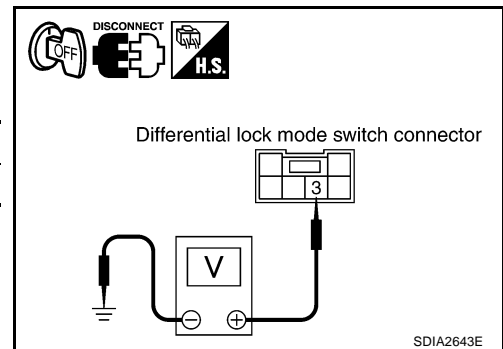

OK or NG

OK >> GO TO 3.

NG >> Check the following. If any items are damaged, repair or replace damaged parts.

- 10A fuse [No. 15, located in fuse block (J/B)]
- Harness for short or open between ignition switch and differential lock mode switch harness connector terminals 3
- Ignition switch. Refer to [PG-4, "POWER SUPPLY ROUTING CIRCUIT"](#).

3. CHECK DIFFERENTIAL LOCK MODE SWITCH

1. Turn ignition switch "OFF".
2. Disconnect differential lock mode switch harness connector.
3. Operate differential lock mode switch and check continuity between differential lock mode switch terminals.

Terminal	Condition	Continuity
1 - 3	Differential lock mode switch: ON	No
	Differential lock mode switch: OFF	Yes
2 - 3	Differential lock mode switch: ON	Yes
	Differential lock mode switch: OFF	No

OK or NG

OK >> GO TO 4.

NG >> Replace differential lock mode switch.

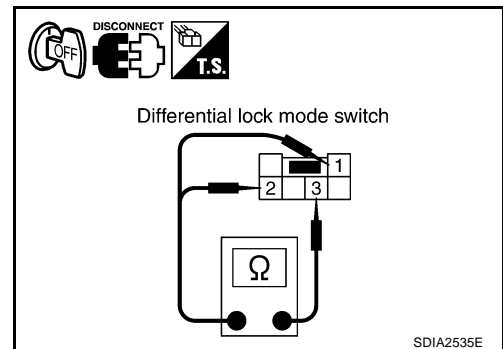

TROUBLE DIAGNOSIS FOR SYSTEM [WITH ELECTRONIC LOCKING DIFFERENTIAL]

4. CHECK HARNESS BETWEEN DIFFERENTIAL LOCK CONTROL UNIT AND DIFFERENTIAL LOCK MODE SWITCH

1. Turn ignition switch "OFF".
2. Disconnect differential lock control unit harness connector and differential lock mode switch harness connector.
3. Check continuity between the following terminals.
 - Differential lock control unit harness connector B77 terminal 9 and differential lock mode switch harness connector M149 terminal 2.
 - Differential lock control unit harness connector B77 terminal 22 and differential lock mode switch harness connector M149 terminal 1.

Continuity should exist.

Also check harness for short to ground and short to power.

OK or NG

- OK >> GO TO 5.
- NG >> Repair or replace damaged parts.

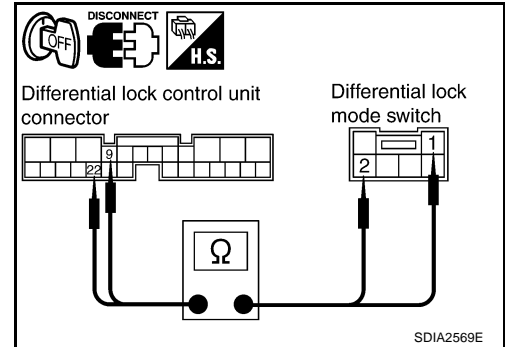

5. CHECK DIFFERENTIAL LOCK CONTROL UNIT

Check differential lock control unit input/output signal. Refer to [RFD-52, "Differential Lock Control Unit Input/Output Signal Reference Values"](#) .

OK or NG

- OK >> GO TO 6.
- NG >> Check differential lock control unit pin terminals for damage or loose connection with harness connector. If any items are damaged, repair or replace damaged parts.

6. CHECK DTC

Perform the self-diagnosis, after driving a vehicle for a while.

OK or NG

- OK >> **INSPECTION END**
- NG >> Replace differential lock control unit. Refer to [RFD-80, "DIFFERENTIAL LOCK CONTROL UNIT"](#)

COMPONENT INSPECTION

1. Turn ignition switch "OFF".
2. Disconnect differential lock mode switch harness connector.
3. Operate differential lock mode switch and check continuity between differential lock mode switch terminals.

Terminal	Condition	Continuity
1 - 3	Differential lock mode switch: ON	No
	Differential lock mode switch: OFF	Yes
2 - 3	Differential lock mode switch: ON	Yes
	Differential lock mode switch: OFF	No

4. If NG, replace differential lock mode switch.

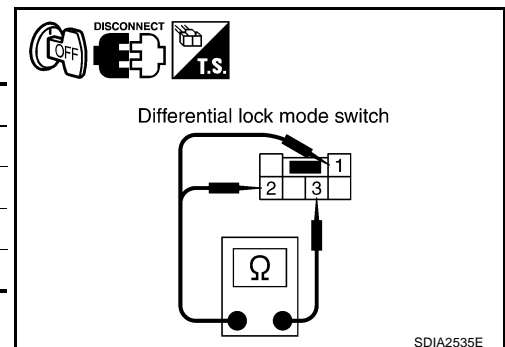

TROUBLE DIAGNOSIS FOR SYSTEM [WITH ELECTRONIC LOCKING DIFFERENTIAL]

EDS0030G

Differential Lock Position Switch CONSULT-II REFERENCE VALUE IN DATA MONITOR MODE

Data are reference value.

Monitor item	Content	Condition	Display value
D-LOCK POS SW [ON/OFF]	Condition of differential lock position switch	<ul style="list-style-type: none"> ● Vehicle stopped ● Engine running 	Differential lock mode switch: ON (DIFF LOCK indicator lamp: ON)
		<ul style="list-style-type: none"> ● VDC OFF switch: ON ● 4WD shift switch: 4LO 	Differential lock mode switch: OFF (DIFF LOCK indicator lamp: OFF)

DIFFERENTIAL CONTROL UNIT TERMINALS AND REFERENCE VALUE

Data are reference value and are measured between each terminal and ground.

Terminal	Wire color	Item	Condition	Data (Approx.)
20	W/R	Differential lock position switch	<ul style="list-style-type: none"> ● Vehicle stopped ● Engine running 	Differential lock mode switch: ON (DIFF LOCK indicator lamp: ON)
			<ul style="list-style-type: none"> ● VDC OFF switch: ON ● 4WD shift switch: 4LO 	Differential lock mode switch: OFF (DIFF LOCK indicator lamp: OFF)

CAUTION:

When using a circuit tester to measure voltage for inspection, be sure not to extend forcibly any connector terminals.

TROUBLE DIAGNOSIS FOR SYSTEM [WITH ELECTRONIC LOCKING DIFFERENTIAL]

DIAGNOSTIC PROCEDURE

1. CHECK DIFFERENTIAL LOCK POSITION SWITCH SIGNAL

④ With CONSULT-II

- Start engine.
- Select "DATA MONITOR" mode for "DIFF LOCK" with CONSULT-II.
- Read out ON/OFF switching action of "D-LOCK POS SW SIG".

Monitor item	Condition		Display value
D-LOCK POS SW SIG	<ul style="list-style-type: none"> Vehicle stopped Engine running VDC OFF switch: ON 4WD shift switch: 4LO 	Differential lock mode switch: ON (DIFF LOCK indicator lamp: ON)	ON
		Differential lock mode switch: OFF (DIFF LOCK indicator lamp: OFF)	OFF

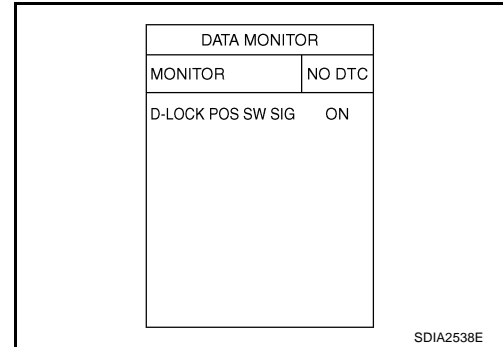

⊗ Without CONSULT-II

- Start engine.
- Check voltage between differential lock control unit harness connector terminal and ground.

Connector	Terminal	Condition		Voltage (Approx.)
B77	20 - Ground	<ul style="list-style-type: none"> Vehicle stopped Engine running VDC OFF switch: ON 4WD shift switch: 4LO 	Differential lock mode switch: ON (DIFF LOCK indicator lamp: ON)	0V
			Differential lock mode switch: OFF (DIFF LOCK indicator lamp: OFF)	Battery voltage

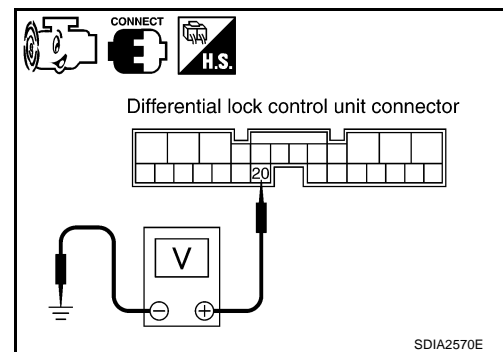

OK or NG

- OK >> GO TO 5.
NG >> GO TO 2.

2. CHECK GROUND CIRCUIT

- Turn ignition switch OFF.
- Disconnect differential lock position switch harness connector.
- Check continuity between differential lock position switch harness connector C16 terminal 3 and ground.

Continuity should exist.

Also check harness for short to power.

OK or NG

- OK >> GO TO 3.
NG >> Repair open circuit or short to power in harness or connectors.

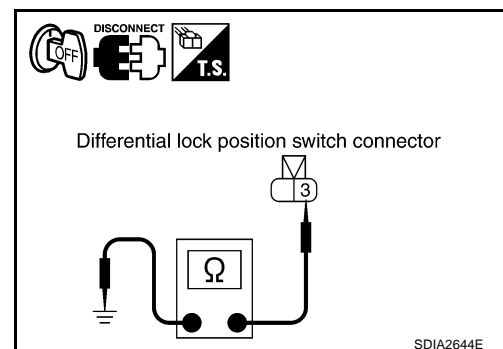

TROUBLE DIAGNOSIS FOR SYSTEM [WITH ELECTRONIC LOCKING DIFFERENTIAL]

3. CHECK DIFFERENTIAL LOCK POSITION SWITCH

📖 With CONSULT-II

1. Turn ignition switch ON.
2. Select "DATA MONITOR" mode for "DIFF LOCK" with CONSULT-II.
3. Read out ON/OFF switching action of "D-LOCK POS SW SIG" while connecting and disconnecting jumper wire between differential lock position switch harness connector C16 terminals 1 and 3.

Monitor item	Condition	Display value
D-LOCK POS SW SIG	Jumper wire connected	ON
	Jumper wire disconnected	OFF

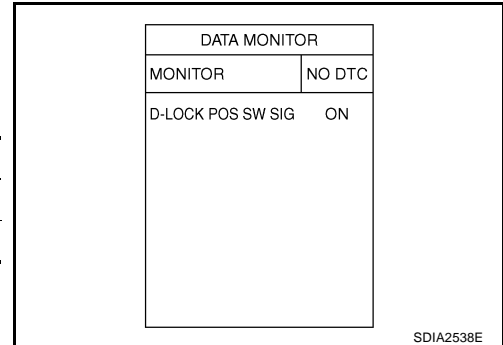

⊗ Without CONSULT-II

1. Turn ignition switch ON.
2. Check voltage between differential lock control unit harness connector terminal and ground while connecting and disconnecting jumper wire between differential lock position switch harness connector C16 terminals 1 and 3.

Connector	Terminal	Condition	Voltage (Approx.)
B77	20 - Ground	Jumper wire connected	0V
		Jumper wire disconnected	Battery voltage

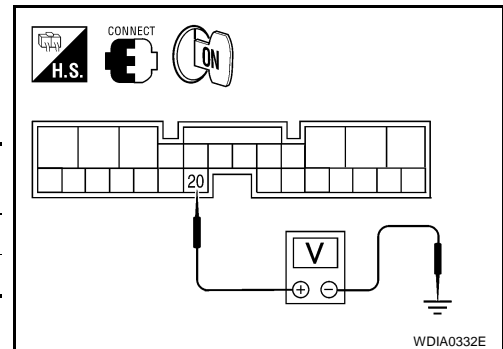

OK or NG

- OK >> Replace differential lock position switch. Refer to [RFD-81, "Removal and Installation"](#).
- NG >> GO TO 4.

4. CHECK HARNESS BETWEEN DIFFERENTIAL LOCK CONTROL UNIT AND DIFFERENTIAL LOCK POSITION SWITCH

1. Turn ignition switch OFF.
2. Disconnect differential lock control unit harness connector.
3. Check continuity between differential lock control unit harness connector B77 terminal 20 and differential lock position switch harness connector C16 terminal 1.

Continuity should exist.

Also check harness for short to ground and short to power.

OK or NG

- OK >> GO TO 5.
- NG >> Repair or replace damaged parts.

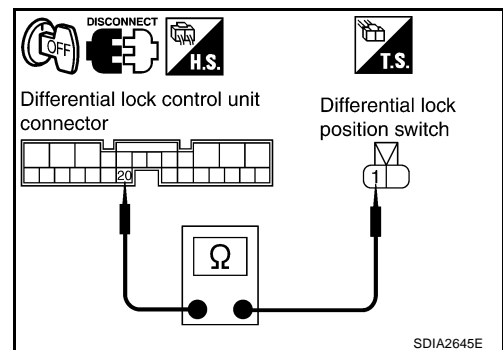

TROUBLE DIAGNOSIS FOR SYSTEM [WITH ELECTRONIC LOCKING DIFFERENTIAL]

5. CHECK DIFFERENTIAL LOCK CONTROL UNIT

Check differential lock control unit input/output signal. Refer to [RFD-52, "Differential Lock Control Unit Input/Output Signal Reference Values"](#) .

OK or NG

OK >> GO TO 6.

NG >> Check differential lock control unit pin terminals for damage or loose connection with harness connector. If any items are damaged, repair or replace damaged parts.

6. CHECK DTC

Perform the self-diagnosis, after driving a vehicle for a while.

OK or NG

OK >> **INSPECTION END**

NG >> Replace differential lock control unit. Refer to [RFD-80, "DIFFERENTIAL LOCK CONTROL UNIT"](#)

Differential Lock Solenoid Relay CONSULT-II REFERENCE VALUE IN DATA MONITOR MODE

EDS0030H

Data are reference value.

Monitor item	Content	Condition	Display value
RELAY ON [ON/OFF]	Operating condition of differential lock solenoid relay (integrated in differential lock control unit)	<ul style="list-style-type: none"> ● Vehicle stopped ● Engine running ● VDC OFF switch: ON ● 4WD shift switch: 4LO 	Differential lock mode switch: ON ON
			Differential lock mode switch: OFF OFF

DIAGNOSTIC PROCEDURE

1. CHECK DIFFERENTIAL LOCK SOLENOID SYSTEM

Perform self-diagnosis. Refer to [RFD-55, "SELF-DIAG RESULTS MODE"](#) .

Is "RELAY [P1844]" displayed?

YES >> Perform trouble diagnosis for differential lock solenoid. Refer to [RFD-68, "Differential Lock Solenoid"](#) .

NO >> GO TO 2.

2. CHECK DIFFERENTIAL LOCK SOLENOID RELAY SIGNAL

 With CONSULT-II

1. Start engine.
2. Select "DATA MONITOR" mode for "DIFF LOCK" with CONSULT-II.
3. Read out ON/OFF switching action of "RELAY ON".

Monitor item	Condition	Display value
RELAY ON	<ul style="list-style-type: none"> ● Vehicle stopped ● Engine running ● VDC OFF switch: ON ● 4WD shift switch: 4LO 	Differential lock mode switch: ON ON
		Differential lock mode switch: OFF OFF

OK or NG

OK >> GO TO 4.

NG >> GO TO 3.

DATA MONITOR	
MONITOR	NO DTC
RELAY ON	ON

SDIA2642E

TROUBLE DIAGNOSIS FOR SYSTEM [WITH ELECTRONIC LOCKING DIFFERENTIAL]

3. CHECK DIFFERENTIAL LOCK CONTROL UNIT

Check differential lock control unit input/output signal. Refer to [RFD-52, "Differential Lock Control Unit Input/Output Signal Reference Values"](#) .

OK or NG

OK >> GO TO 4.

NG >> Check differential lock control unit pin terminals for damage or loose connection with harness connector. If any item is damaged, repair or replace damaged parts.

4. CHECK DTC

Perform the self-diagnosis, after driving a vehicle for a while.

OK or NG

OK >> **INSPECTION END**

NG >> Replace differential lock control unit. Refer to [RFD-80, "DIFFERENTIAL LOCK CONTROL UNIT"](#)

Differential Lock Solenoid CONSULT-II REFERENCE VALUE IN DATA MONITOR MODE

EDS00301

Data are reference value.

Monitor item	Content	Condition	Display value
RELAY ON [ON/OFF]	Operating condition of differential lock solenoid relay (integrated in differential lock control unit)	<ul style="list-style-type: none"> ● Vehicle stopped ● Engine running ● VDC OFF switch: ON ● 4WD shift switch: 4LO 	Differential lock mode switch: ON ON
			Differential lock mode switch: OFF OFF
RELAY MTR [ON/OFF]	Control status of differential lock solenoid relay (integrated in differential lock control unit)	<ul style="list-style-type: none"> ● Vehicle stopped ● Engine running ● VDC OFF switch: ON ● 4WD shift switch: 4LO 	Differential lock mode switch: ON ON
			Differential lock mode switch: OFF OFF
SOL MTR [ON/OFF]	Control status of differential lock solenoid	<ul style="list-style-type: none"> ● Vehicle stopped ● Engine running ● VDC OFF switch: ON ● 4WD shift switch: 4LO 	Differential lock mode switch: ON ON
			Differential lock mode switch: OFF OFF

DIFFERENTIAL LOCK CONTROL UNIT TERMINALS AND REFERENCE VALUE

Data are reference value and are measured between each terminal and ground.

Terminal	Wire color	Item	Condition	Data (Approx.)
11	V	Differential lock solenoid (-)	<ul style="list-style-type: none"> ● Vehicle stopped ● Engine running ● VDC OFF switch: ON ● 4WD shift switch: 4LO 	Differential lock mode switch: ON 0V
				Differential lock mode switch: OFF Battery voltage
12	Y	Differential lock solenoid (+)	<ul style="list-style-type: none"> ● Vehicle stopped ● Engine running ● VDC OFF switch: ON ● 4WD shift switch: 4LO 	Differential lock mode switch: ON 0V
				Differential lock mode switch: OFF Battery voltage

CAUTION:

When using a circuit tester to measure voltage for inspection, be sure not to extend forcibly any connector terminals.

TROUBLE DIAGNOSIS FOR SYSTEM [WITH ELECTRONIC LOCKING DIFFERENTIAL]

DIAGNOSTIC PROCEDURE

1. CHECK DIFFERENTIAL SOLENOID SIGNAL

Ⓜ With CONSULT-II

1. Start engine.
2. Select "DATA MONITOR" mode for "DIFF LOCK" with CONSULT-II.
3. Read out ON/OFF switching action of "RELAY ON", "RELAY MTR", "SOL MTR".

Monitor item	Condition		Display value
RELAY ON	<ul style="list-style-type: none"> ● Vehicle stopped ● Engine running ● VDC OFF switch: ON ● 4WD shift switch: 4LO 	Differential lock mode switch: ON	ON
		Differential lock mode switch: OFF	OFF
RELAY MTR		Differential lock mode switch: ON	ON
		Differential lock mode switch: OFF	OFF
SOL MTR	Differential lock mode switch: ON	ON	
	Differential lock mode switch: OFF	OFF	

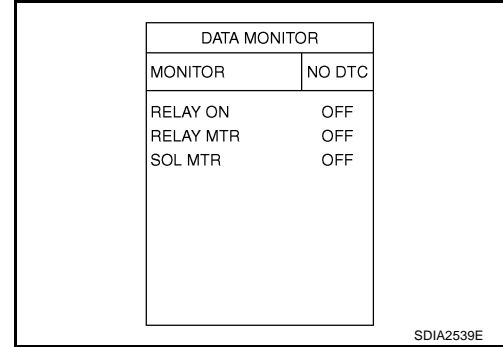

ⓧ Without CONSULT-II

1. Start engine.
2. Check voltage between differential lock control unit harness connector terminal and ground.

Connector	Terminal	Condition	Data (Approx.)	
B77	11 - Ground	<ul style="list-style-type: none"> ● Vehicle stopped ● Engine running ● VDC OFF switch: ON ● 4WD shift switch: 4LO 	Differential lock mode switch: ON	0V
			Differential lock mode switch: OFF	Battery voltage
	12 - Ground		Differential lock mode switch: ON	0V
			Differential lock mode switch: OFF	Battery voltage

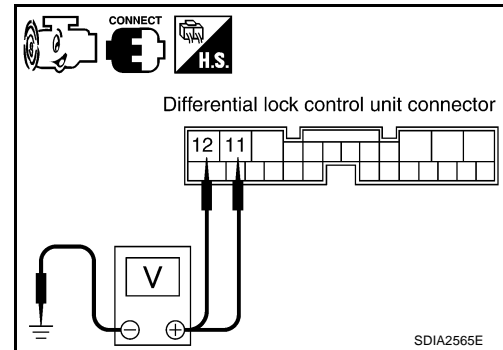

OK or NG

- OK >> GO TO 6.
- NG >> GO TO 2.

TROUBLE DIAGNOSIS FOR SYSTEM [WITH ELECTRONIC LOCKING DIFFERENTIAL]

2. CHECK DIFFERENTIAL LOCK SOLENOID CIRCUIT

1. Turn ignition switch "OFF".
2. Disconnect differential lock control unit harness connector.
3. Check resistance between differential lock control unit harness connector terminals 11 and 12.

Connector	Terminal	Resistance (Approx.)
B77	11 - 12	3.4 Ω

OK or NG

- OK >> GO TO 6.
- NG >> GO TO 3.

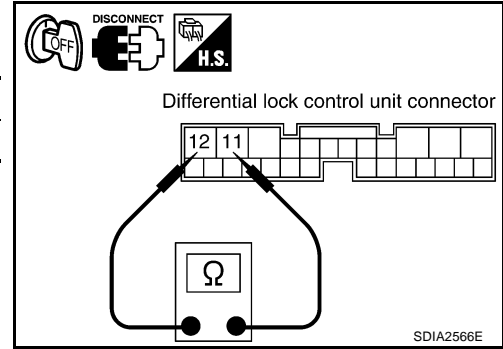

3. CHECK DIFFERENTIAL LOCK SOLENOID RESISTANCE

1. Turn ignition switch "OFF".
2. Disconnect differential lock solenoid harness connector.
3. Check resistance between differential lock solenoid terminals 2 and 4.

2 - 4 : Approx. 3.4Ω

OK or NG

- OK >> GO TO 4.
- NG >> Replace differential solenoid. Refer to [RFD-93, "Differential Assembly"](#).

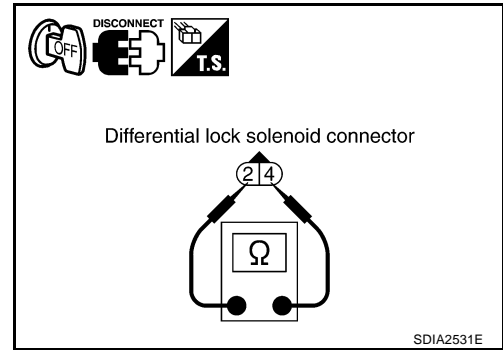

4. CHECK DIFFERENTIAL LOCK SOLENOID OPERATION

1. Turn ignition switch "OFF".
2. Disconnect differential lock solenoid harness connector.
3. Check operation by applying battery voltage to differential lock solenoid terminals.

CAUTION:

Be sure to apply the voltage of the correct polarity to the respective terminals. Otherwise, the part may be damaged.

Terminal
4 (Battery voltage) - 2 (Ground)

Does solenoid operate?

- YES >> GO TO 5.
- NO >> Replace differential solenoid. Refer to [RFD-93, "Differential Assembly"](#).

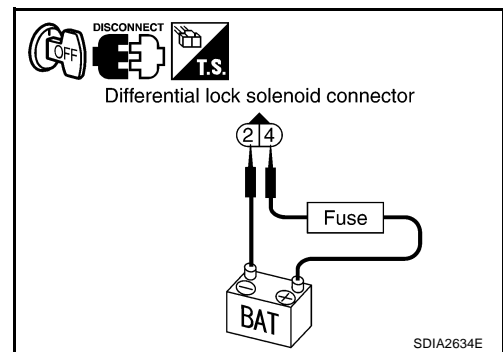

TROUBLE DIAGNOSIS FOR SYSTEM [WITH ELECTRONIC LOCKING DIFFERENTIAL]

5. CHECK HARNESS BETWEEN DIFFERENTIAL LOCK CONTROL UNIT AND DIFFERENTIAL LOCK SOLENOID

1. Turn ignition switch "OFF".
2. Disconnect differential lock control unit harness connector and differential lock solenoid harness connector.
3. Check continuity between the following terminals.
 - Differential lock control unit harness connector B77 terminal 11 and differential lock solenoid harness connector C17 terminal 2.
 - Differential lock control unit harness connector B77 terminal 12 and differential lock solenoid harness connector C17 terminal 4.

11 - 2 : Continuity should exist.

12 - 4 : Continuity should exist.

Also check harness for short to ground and short to power.

OK or NG

OK >> GO TO 6.

NG >> Repair or replace damaged parts.

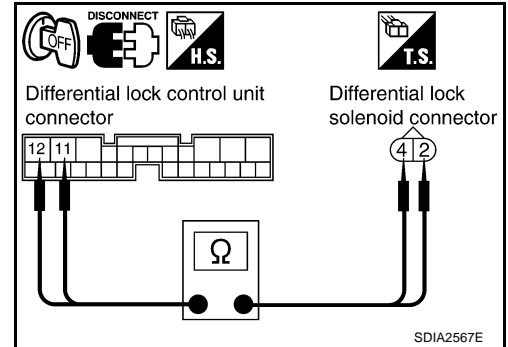

6. CHECK DIFFERENTIAL LOCK CONTROL UNIT

Check differential lock control unit input/output signal. Refer to [RFD-52, "Differential Lock Control Unit Input/Output Signal Reference Values"](#).

OK or NG

OK >> GO TO 7.

NG >> Check differential lock control unit pin terminals for damage or loose connection with harness connector. If any items are damaged, repair or replace damaged parts.

7. CHECK DTC

Perform the self-diagnosis, after driving a vehicle for a while.

OK or NG

OK >> **INSPECTION END**

NG >> Replace differential lock control unit. Refer to [RFD-80, "DIFFERENTIAL LOCK CONTROL UNIT"](#)

TROUBLE DIAGNOSIS FOR SYSTEM [WITH ELECTRONIC LOCKING DIFFERENTIAL]

COMPONENT INSPECTION

1. Turn ignition switch "OFF".
2. Disconnect differential lock solenoid harness connector.
3. Check resistance between differential lock solenoid terminals 2 and 4.

2 - 4 : Approx. 3.4Ω

4. If NG, replace differential lock solenoid. Refer to [RFD-93, "Differential Assembly"](#).

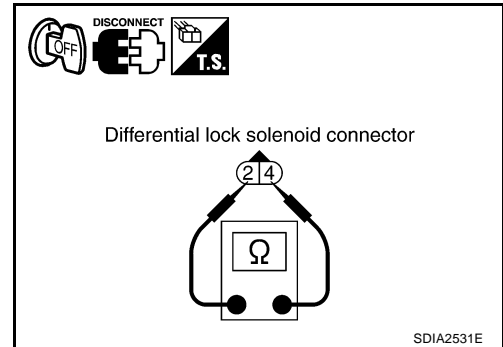

5. Check operation by applying battery voltage to differential lock solenoid terminals.

CAUTION:

Be sure to apply the voltage of the correct polarity to the respective terminals. Otherwise, the part may be damaged.

Terminal
4 (Battery voltage) - 2 (Ground)

6. If NG, replace differential lock solenoid.

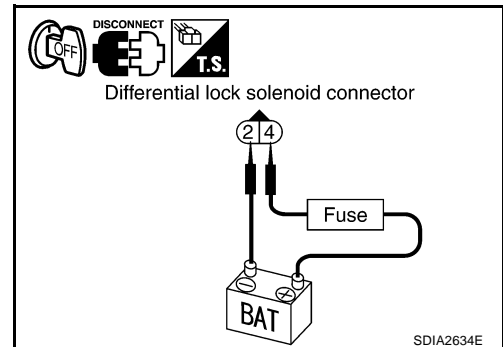

EDS0030J

ABS System DIAGNOSTIC PROCEDURE

1. CHECK DTC WITH ABS ACTUATOR AND ELECTRIC UNIT (CONTROL UNIT)

Perform self-diagnosis with ABS actuator and electric unit (control unit). Refer to [BRC-24, "SELF-DIAGNOSIS"](#).

Is any malfunction detected by self-diagnosis?

- YES >> Check the malfunctioning system.
- NO >> GO TO 2.

2. CHECK DIFFERENTIAL LOCK CONTROL UNIT

Check differential lock control unit input/output signal. Refer to [RFD-52, "Differential Lock Control Unit Input/Output Signal Reference Values"](#).

OK or NG

- OK >> GO TO 3.
- NG >> Check differential lock control unit pin terminals for damage or loose connection with harness connector. If any items are damaged, repair or replace damaged parts.

3. CHECK DTC

Perform the self-diagnosis, after driving a vehicle for a while.

OK or NG

- OK >> **INSPECTION END**
- NG >> Perform self-diagnosis with ABS actuator and electric unit (control unit) again. Refer to [BRC-24, "SELF-DIAGNOSIS"](#).

TROUBLE DIAGNOSIS FOR SYSTEM [WITH ELECTRONIC LOCKING DIFFERENTIAL]

CAN Communication Line DIAGNOSTIC PROCEDURE

EDS0030K

1. CHECK CAN COMMUNICATION CIRCUIT

ⓐ With CONSULT-II

1. Turn ignition switch "ON" and start engine.
2. Select "SELF-DIAG RESULTS" mode for "DIFF LOCK" with in CONSULT-II.
3. Perform the self-diagnosis.

Is the "CAN COMM CIRCUIT [U1000]" displayed?

- YES >> Go to [LAN-5, "Precautions When Using CONSULT-II"](#) .
NO >> **INSPECTION END**

SELF-DIAG RESULTS	
DTC RESULTS	TIME
CAN COMM CIRCUIT [U1000]	0
ERASE	PRINT

SDIA1850E

A
B
C
RFD
E
F
G
H
I
J
K
L
M

TROUBLE DIAGNOSIS FOR SYMPTOMS [WITH ELECTRONIC LOCKING DIFFERENTIAL]

PFP:00007

EDS0030L

TROUBLE DIAGNOSIS FOR SYMPTOMS

DIFF LOCK Indicator Lamp Does Not Turn ON

SYMPTOM:

DIFF LOCK indicator lamp does not turn ON for approx. 1 second when turning ignition switch to "ON".

DIAGNOSTIC PROCEDURE

1. CHECK SYSTEM FOR CAN COMMUNICATION LINE

Perform self-diagnosis. Refer to [RFD-55, "SELF-DIAG RESULTS MODE"](#).

Is "CAN COMM CIRCUIT" displayed?

YES >> Perform trouble diagnosis for CAN communication line. Refer to [RFD-73, "CAN Communication Line"](#).

NO >> GO TO 2.

2. CHECK DIFFERENTIAL LOCK CONTROL UNIT POWER SUPPLY

1. Turn ignition switch "OFF".
2. Disconnect differential lock control unit harness connector.
3. Check voltage between differential lock control unit harness connector terminals and ground.

Connector	Terminal	Voltage (Approx.)
B77	1 - Ground	0V
	2 - Ground	0V
	15 - Ground	Battery voltage

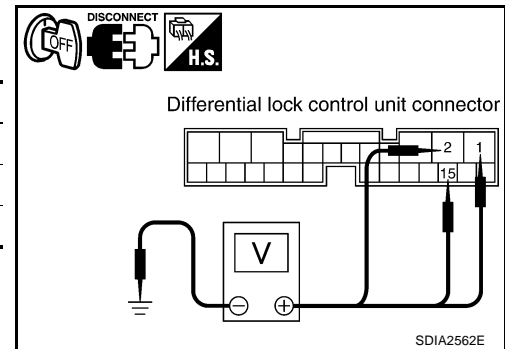

4. Turn ignition switch "ON". (Do not start engine.)
5. Check voltage between differential lock control unit harness connector terminals and ground.

Connector	Terminal	Voltage (Approx.)
B77	1 - Ground	Battery voltage
	2 - Ground	
	15 - Ground	

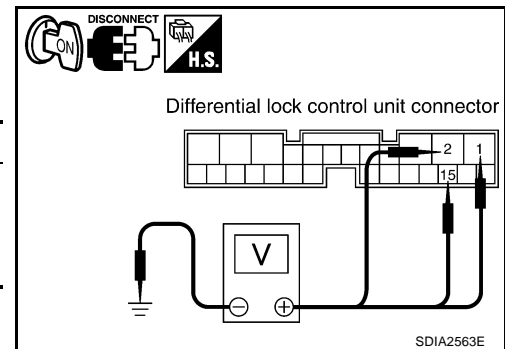

OK or NG

OK >> GO TO 3.

NG >> Check the following. If any items are damaged, repair or replace damaged parts.

- 10A fuse [No. 15 or 19, located in fuse block (J/B)]
- Harness for short or open between battery and differential lock control unit harness connector terminal 15
- Harness for short or open between ignition switch and differential lock control unit harness connector terminals 1 and 2
- Battery and ignition switch. Refer to [PG-4, "POWER SUPPLY ROUTING CIRCUIT"](#).

TROUBLE DIAGNOSIS FOR SYMPTOMS [WITH ELECTRONIC LOCKING DIFFERENTIAL]

3. CHECK DIFFERENTIAL LOCK CONTROL UNIT GROUND CIRCUIT

1. Turn ignition switch "OFF".
2. Disconnect differential lock control unit harness connector.
3. Check continuity between differential lock control unit harness connector B77 terminals 3, 10 and ground.

Continuity should exist.

Also check harness for short to ground and short to power.

OK or NG

OK >> GO TO 4.

NG >> Repair open circuit or short to ground or short to power in harness or connectors.

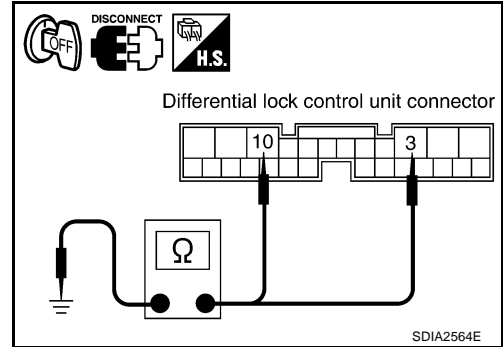

4. CHECK COMBINATION METER POWER SUPPLY CIRCUIT

1. Turn ignition switch "OFF".
2. Disconnect combination meter harness connector.
3. Check voltage between combination meter harness connector terminal and ground

Connector	Terminal	Voltage (Approx.)
M24	24 - Ground	0V

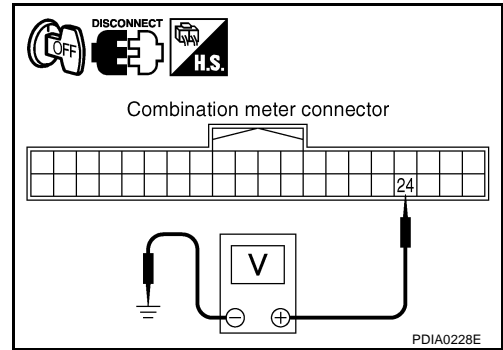

4. Turn ignition switch "ON". (Do not start engine.)
5. Check voltage between combination meter harness connector terminal and ground.

Connector	Terminal	Voltage (Approx.)
M24	24 - Ground	0V

OK or NG

OK >> GO TO 5.

NG >> Check the following. If any items are damaged, repair or replace damaged parts.

- 10A fuse [No.14, located in the fuse block (J/B)]
- Harness for short or open between ignition switch and combination meter harness connector terminal 24
- Ignition switch. Refer to [PG-4, "POWER SUPPLY ROUTING CIRCUIT"](#) .

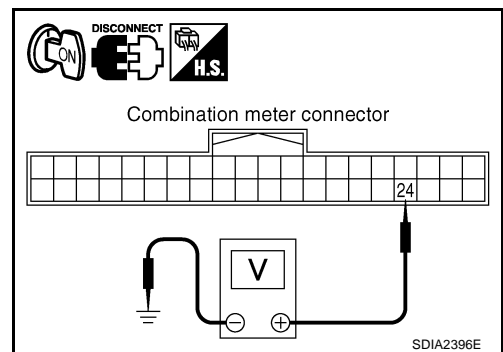

TROUBLE DIAGNOSIS FOR SYMPTOMS [WITH ELECTRONIC LOCKING DIFFERENTIAL]

5. CHECK HARNESS BETWEEN DIFFERENTIAL LOCK CONTROL UNIT AND COMBINATION METER

1. Turn ignition switch "OFF".
2. Disconnect differential lock control unit harness connector and combination meter harness connector.
3. Check continuity between differential lock control unit harness connector B77 terminal 21 and combination meter harness connector M24 terminal 14.

Continuity should exist.

Also check harness for short to ground and short to power.

OK or NG

- OK >> GO TO 6.
NG >> Repair or replace damaged parts.

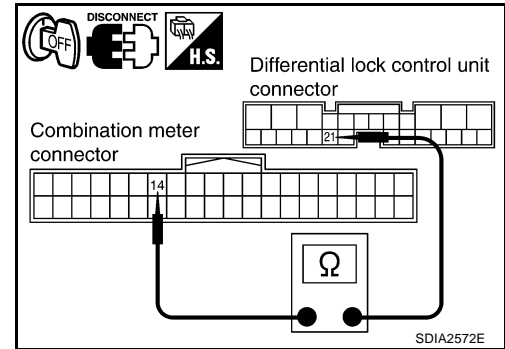

6. CHECK DIFF LOCK INDICATOR LAMP CIRCUIT

1. Turn ignition switch "OFF".
2. Check combination meter. Refer to [DI-8, "Combination Meter"](#).

OK or NG

- OK >> GO TO 7.
NG >> Replace combination meter. Refer to [IP-13, "COMBINATION METER"](#).

7. CHECK SYMPTOM

Check again.

OK or NG

- OK >> **INSPECTION END**
NG >> GO TO 8.

8. CHECK DIFFERENTIAL LOCK CONTROL UNIT

Check differential lock control unit input/output signal. Refer to [RFD-52, "Differential Lock Control Unit Input/Output Signal Reference Values"](#).

OK or NG

- OK >> **INSPECTION END**
NG >> Check differential lock control unit pin terminals for damage or loose connection with harness connector. If any items are damaged, repair or replace damaged parts.

TROUBLE DIAGNOSIS FOR SYMPTOMS [WITH ELECTRONIC LOCKING DIFFERENTIAL]

EDS0030M

DIFF LOCK Indicator Lamp Does Not Change

SYMPTOM:

DIFF LOCK indicator lamp does not change when turning differential lock mode switch to "ON" after engine start.

DIAGNOSTIC PROCEDURE

1. CHECK DIFF LOCK INDICATOR LAMP

Confirm DIFF LOCK indicator lamp when ignition switch is turned to ON.

Does DIFF LOCK indicator lamp turn on?

YES >> GO TO 2.

NO >> Go to [RFD-74, "DIFF LOCK Indicator Lamp Does Not Turn ON"](#) .

2. CHECK SELF-DIAGNOSTIC RESULTS

Perform self-diagnosis. Refer to [RFD-55, "SELF-DIAG RESULTS MODE"](#) .

Is any malfunction detected by self-diagnosis?

YES >> Check the malfunctioning system.

NO >> GO TO 3.

3. CHECK SYSTEM FOR DIFFERENTIAL LOCK MODE SWITCH

Perform trouble diagnosis for differential lock mode switch system. Refer to [RFD-60, "Differential Lock Mode Switch"](#) .

OK or NG

OK >> GO TO 4.

NG >> Repair or replace damaged parts.

4. CHECK DIFF LOCK INDICATOR LAMP CIRCUIT

1. Turn ignition switch "OFF".

2. Check combination meter. Refer to [DI-8, "Combination Meter"](#) .

OK or NG

OK >> GO TO 5.

NG >> Replace combination meter. Refer to [IP-13, "COMBINATION METER"](#) .

5. CHECK SYMPTOM

Check again.

OK or NG

OK >> **INSPECTION END**

NG >> GO TO 6.

6. CHECK DIFFERENTIAL LOCK CONTROL UNIT

Check differential lock control unit input/output signal. Refer to [RFD-52, "Differential Lock Control Unit Input/Output Signal Reference Values"](#) .

OK or NG

OK >> **INSPECTION END**

NG >> Check differential lock control unit pin terminals for damage or loose connection with harness connector. If any items are damaged, repair or replace damaged parts.

TROUBLE DIAGNOSIS FOR SYMPTOMS [WITH ELECTRONIC LOCKING DIFFERENTIAL]

EDS0030N

DIFF LOCK Indicator Lamp Sometimes Flashes

SYMPTOM:

DIFF LOCK indicator lamp sometimes flashes when it turns ON or OFF during driving.

DIAGNOSTIC PROCEDURE

1. CHECK DIFF LOCK INDICATOR LAMP

Confirm DIFF LOCK indicator lamp when ignition switch is turned to ON.

Does DIFF LOCK indicator lamp turn on?

YES >> GO TO 2.

NO >> Go to [RFD-74, "DIFF LOCK Indicator Lamp Does Not Turn ON"](#) .

2. CHECK SELF-DIAGNOSTIC RESULTS

Perform self-diagnosis. Refer to [RFD-55, "SELF-DIAG RESULTS MODE"](#) .

Is any malfunction detected by self-diagnosis?

YES >> Check the malfunctioning system.

NO >> GO TO 3.

3. CHECK SYSTEM FOR DIFFERENTIAL LOCK MODE SWITCH

Perform trouble diagnosis for differential lock mode switch system. Refer to [RFD-60, "Differential Lock Mode Switch"](#) .

OK or NG

OK >> GO TO 4.

NG >> Repair or replace damaged parts.

4. CHECK SYSTEM FOR DIFFERENTIAL POSITION SWITCH

Perform trouble diagnosis for differential lock position switch system. Refer to [RFD-64, "Differential Lock Position Switch"](#) .

OK or NG

OK >> GO TO 5.

NG >> Repair or replace damaged parts.

5. CHECK SYMPTOM

Check again.

OK or NG

OK >> **INSPECTION END**

NG >> GO TO 6.

6. CHECK DIFFERENTIAL LOCK CONTROL UNIT

Check differential lock control unit input/output signal. Refer to [RFD-52, "Differential Lock Control Unit Input/Output Signal Reference Values"](#) .

OK or NG

OK >> GO TO 7.

NG >> Check differential lock control unit pin terminals for damage or loose connection with harness connector. If any items are damaged, repair or replace damaged parts.

TROUBLE DIAGNOSIS FOR SYMPTOMS [WITH ELECTRONIC LOCKING DIFFERENTIAL]

7. CHECK DIFFERENTIAL INNER PARTS

1. Disassemble rear final drive assembly. Refer to [RFD-89, "Disassembly and Assembly"](#) .
2. Check differential inner parts.

OK or NG

- OK >> **INSPECTION END**
NG >> Repair or replace damaged parts.

A

B

C

RFD

E

F

G

H

I

J

K

L

M

DIFFERENTIAL LOCK CONTROL UNIT [WITH ELECTRONIC LOCKING DIFFERENTIAL]

DIFFERENTIAL LOCK CONTROL UNIT

PFP:28496

Removal and Installation REMOVAL

EDS00300

1. Disconnect the battery cable from the negative terminal.
2. Remove jack and tools.
3. Remove upper bracket of center seat belt retractor and belt assembly. Refer to [SB-8, "Removal and Installation of Rear Seat Belt"](#) .
4. Remove the necessary push pins and reposition rear panel out of the way. Refer to [EI-39, "REAR"](#) .
5. Reposition the carpet to access differential lock control unit to disconnect connector.
6. Remove the two nuts and remove differential lock control unit.

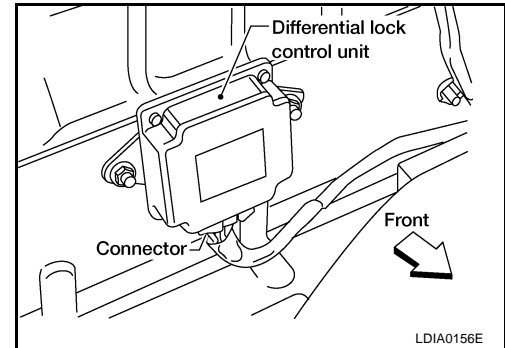

INSTALLATION

Note the following, and installation is in the reverse order of removal.

- When installing differential lock control unit, tighten nuts to the specified torque.

Differential lock control unit nuts : 5.1 N·m (0.52 kg-m, 45 in-lb)

DIFFERENTIAL LOCK POSITION SWITCH [WITH ELECTRONIC LOCKING DIFFERENTIAL]

PFP:28496

DIFFERENTIAL LOCK POSITION SWITCH

EDS0030P

Removal and Installation REMOVAL

Differential Lock Position Switch

CAUTION:

- Do not damage spline, companion flange and front oil seal when removing propeller shaft.
- Before removing final drive assembly or rear axle assembly, disconnect ABS sensor harness connector from the assembly and move it away from final drive/rear axle assembly area. Failure to do so may result in sensor wires being damaged and sensor becoming inoperative.

1. Drain rear final drive gear oil. Refer to [RFD-11, "DRAINING"](#).
2. Remove rear propeller shaft. Refer to [PR-8, "Removal and Installation"](#).
 - Plug rear end of transfer.
3. Remove both RH and LH axle shafts. Refer to [RAX-6, "Removal and Installation"](#).
4. Remove carrier cover bolts.
5. Remove carrier cover using Tool.

Tool number : KV10111100 (J-37228)

CAUTION:

- Do not damage the mating surface.
- Do not insert flat-bladed screwdriver, this will damage the mating surface.

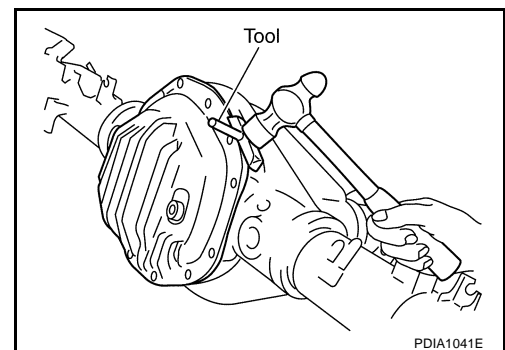

6. Remove differential lock solenoid connector (B) bolt and disconnect differential lock position connector (A).

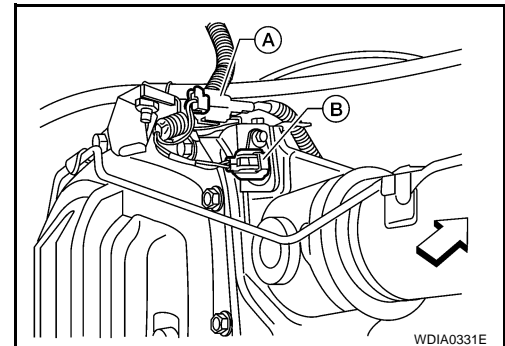

7. For installation, apply a paint matching mark on one side of side bearing cap.

CAUTION:

- Side bearing caps are line-board for initial assembly. The matching marks are used to install them in their original positions.
- For matching mark, use paint. Do not damage side bearing cap.

8. Remove adjuster lock plates.

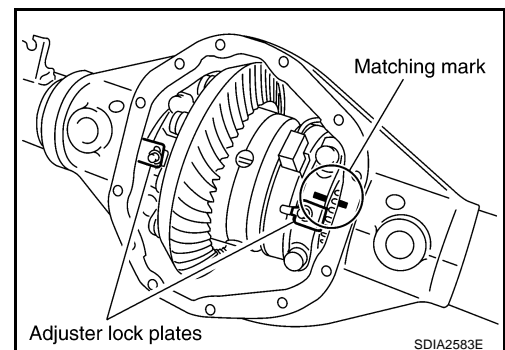

DIFFERENTIAL LOCK POSITION SWITCH [WITH ELECTRONIC LOCKING DIFFERENTIAL]

9. Remove side bearing caps.

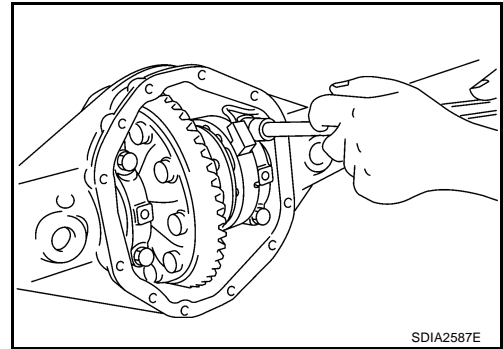

10. Loosen the side bearing adjusters using Tool.

Tool number : — (C - 4164)

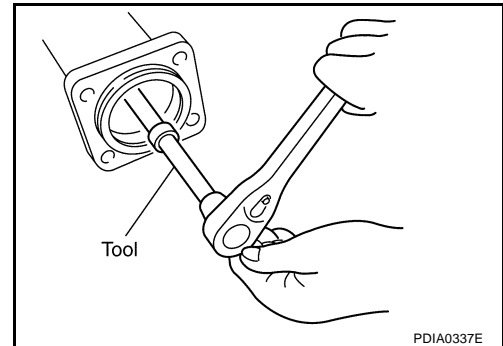

11. Keep side bearing outer races together with inner races. Do not mix them up. Also, keep side bearing adjusters together with bearing.

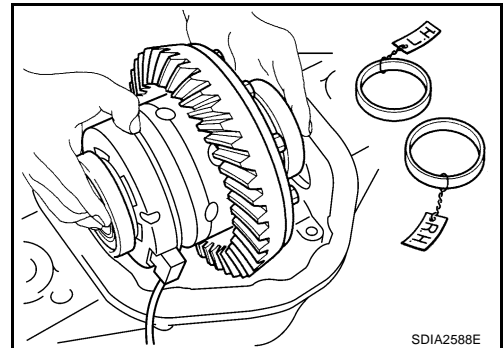

12. Remove side bearing adjusters from axle housing.

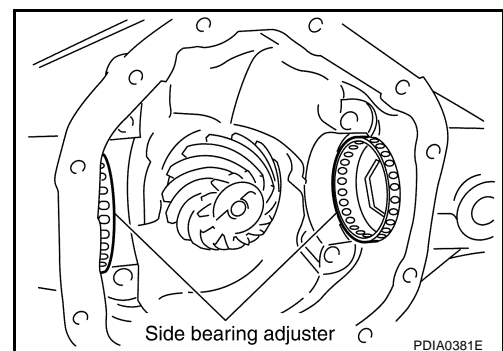

13. Remove bracket for the differential lock position switch connector and bolts.

14. Remove differential lock position switch.

INSTALLATION

1. Apply sealant to threads of differential lock position switch.

- Use Genuine Silicone RTV or equivalent. Refer to [GI-45, "Recommended Chemical Products and Sealants"](#).

CAUTION:

Remove old sealant adhering to axle housing and differential lock position switch. Also remove any moisture, oil, or foreign material adhering to application and axle housing and differential lock position switch.

DIFFERENTIAL LOCK POSITION SWITCH [WITH ELECTRONIC LOCKING DIFFERENTIAL]

2. Install differential lock position switch on axle housing and tighten differential lock position switch bolts with the specified torque. Refer to [RFD-89, "COMPONENTS"](#).

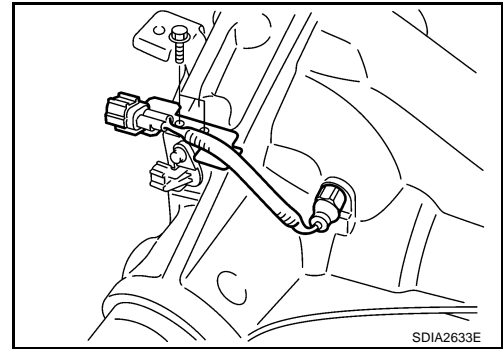

3. Install side bearing adjusters into axle housing.

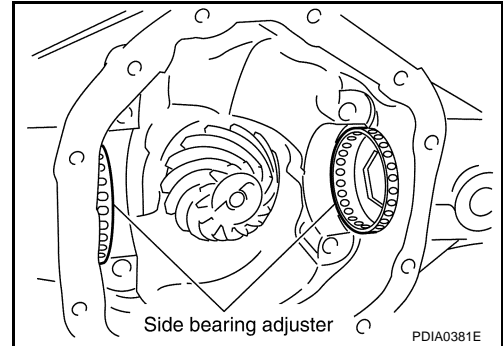

4. Apply gear oil to side bearings. Install differential case assembly with side bearing outer races into axle housing.
5. Apply multi-purpose grease to differential lock position connector.

CAUTION:

Do not reuse sensor connector.

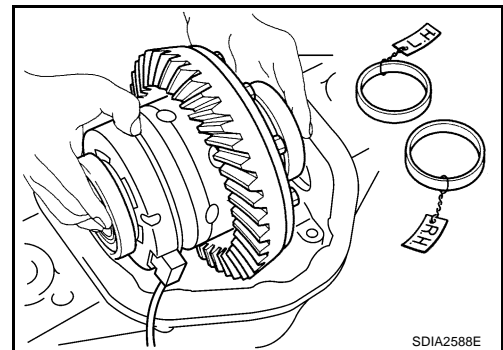

6. Connect differential lock solenoid harness (B) and differential lock position switch connector (A). Then install it to axle housing, tighten to the specified torque. Refer to [RFD-89, "COMPONENTS"](#).

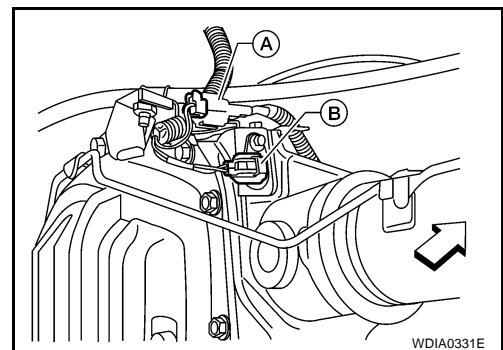

7. Align paint matching mark on side bearing caps with that on axle housing and install side bearing caps on axle housing without tightening to specification.

CAUTION:

Do not tighten at this point. This allows further tightening of side bearing adjusters.

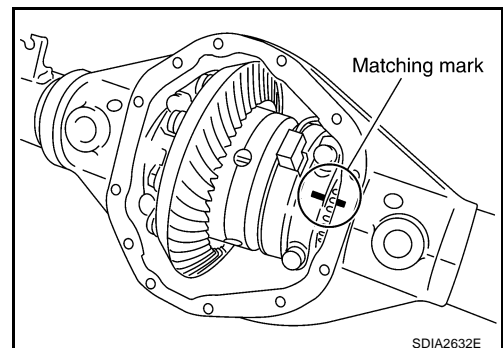

DIFFERENTIAL LOCK POSITION SWITCH [WITH ELECTRONIC LOCKING DIFFERENTIAL]

8. Tighten each side bearing adjusters using adjuster tool.

Tool number : — (C - 4164)

9. Adjusting backlash of drive gear and drive pinion. Refer to [RFD-91, "Backlash"](#) .
10. Check total preload. Refer to [RFD-90, "Total Preload Torque"](#) .
11. Check tooth contact. Refer to [RFD-90, "Tooth Contact"](#) .

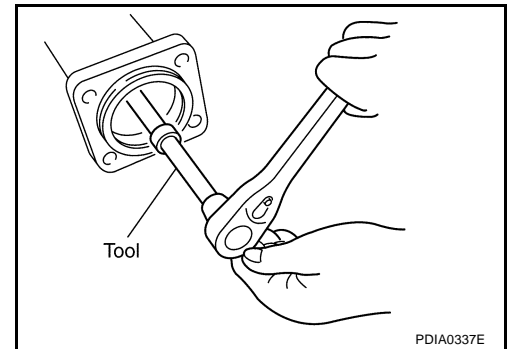

12. Apply sealant to mating surface of carrier cover.

- Use Genuine Silicone RTV or equivalent. Refer to [GI-45, "Recommended Chemical Products and Sealants"](#) .

CAUTION:

Remove old sealant adhering to mating surfaces. Also remove any moisture, oil, or foreign material adhering to application and mating surfaces.

13. Install carrier cover on axle housing and tighten carrier cover bolts with the specified torque. Refer to [RFD-89, "COMPONENTS"](#) .
14. Install both RH and LH axle shafts. Refer to [RAX-8, "INSTALLATION"](#) .
15. Install propeller shaft. Refer to [PR-10, "INSTALLATION"](#) .
16. Refill rear final drive oil. Refer to [RFD-11, "FILLING"](#) .

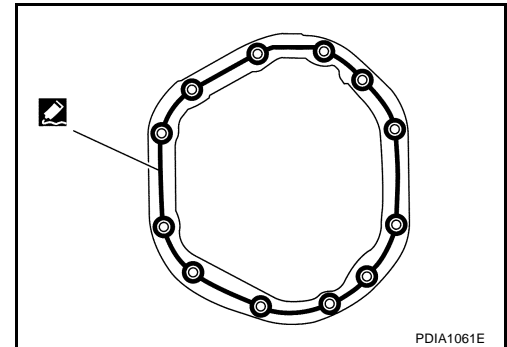

FRONT OIL SEAL [WITH ELECTRONIC LOCKING DIFFERENTIAL]

PFP:38189

FRONT OIL SEAL

Removal and Installation REMOVAL

EDS0030Q

1. Remove rear propeller shaft. Refer to [PR-8, "Removal and Installation"](#) .
2. Remove wheel and tire assemblies.
3. Remove brake calipers and rotors. Refer to [BR-30, "Removal and Installation of Brake Caliper and Disc Rotor"](#) .
4. Using an inch-pound, torque wrench, rotate the pinion three or four times.
5. Record the rotating torque.
6. Loosen drive pinion nut while holding companion flange using Tool.

Tool number : KV40104000 (—)

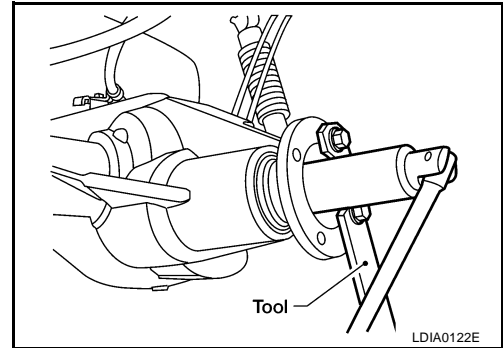

7. Put matching mark on the thread edge of drive pinion. The mark should be in line with the mark on companion flange.

CAUTION:

For matching mark, use paint. Do not damage drive pinion.

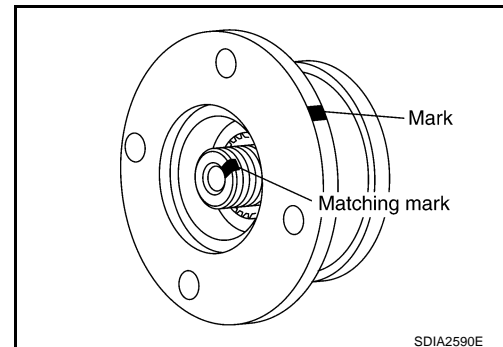

8. Remove companion flange using a suitable tool.

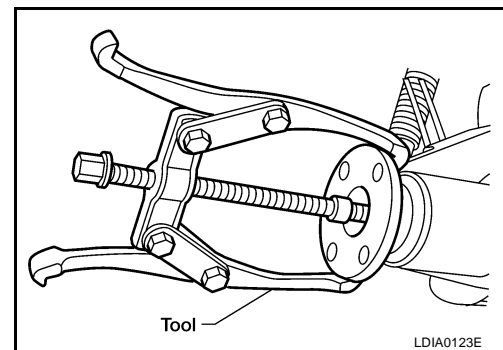

9. Remove front oil seal using Tool.

Tool number : ST33290001 (J-34286)

CAUTION:

Do not damage axle housing.

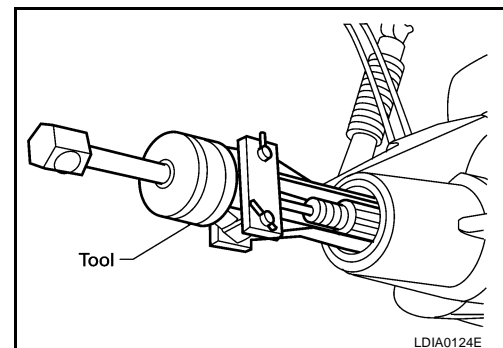

FRONT OIL SEAL [WITH ELECTRONIC LOCKING DIFFERENTIAL]

INSTALLATION

1. Apply multi-purpose grease to oil seal lips. Install front oil seal into axle housing using Tool.

Tool number : ST15310000 (—)

CAUTION:

- Do not reuse oil seal.
- When installing, do not incline oil seal.

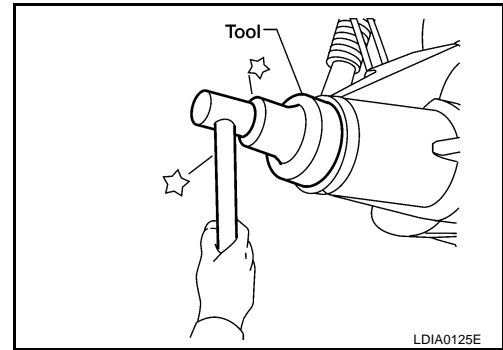

2. Align the matching mark of drive pinion with the mark of companion flange, then install companion flange.

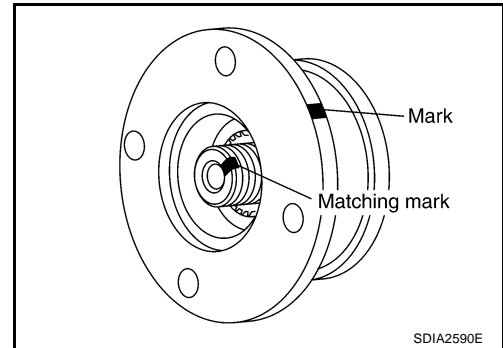

3. Assemble washer if required and new drive pinion nut on pinion gear and tighten nut until there is zero bearing end play.

CAUTION:

Do not reuse drive pinion nut and washer.

4. Rotate drive pinion using an inch-pound torque wrench and flange wrench. Rotating torque should be equal to the reading recorded in step 5 above during removal plus an additional 0.56 N·m (5 in-lb).

Tool number : KV40104000 (—)

5. If the rotating torque is low, continue to tighten drive pinion nut in 6.8 N·m (5 ft-lb) increments until proper rotating torque is achieved. Refer to [RFD-89, "COMPONENTS"](#).

CAUTION:

Do not loosen drive pinion nut to decrease drive pinion rear bearing rotating torque and do not exceed specified preload torque. If preload torque or rotating torque is exceeded a new collapsible spacer must be installed. If the minimum tightening torque is reached prior to reaching the required rotating torque, collapsible spacer may have been damaged. Replace collapsible spacer.

6. Install rear propeller shaft. Refer to [PR-8, "Removal and Installation"](#).
7. Check gear lubricant level and fill with proper lubricant if required. Refer to [RFD-11, "Checking Final Drive Oil"](#).
8. Install brake rotors, calipers, wheel and tire assemblies. Refer to [BR-30, "Removal and Installation of Brake Caliper and Disc Rotor"](#).

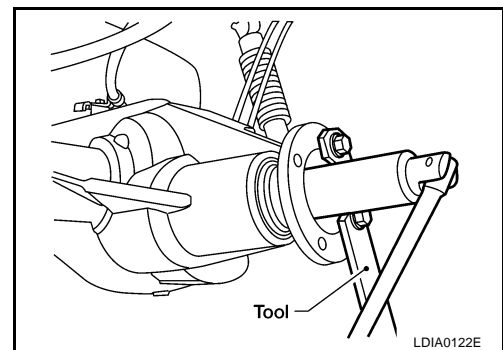

CARRIER COVER [WITH ELECTRONIC LOCKING DIFFERENTIAL]

PF3:38351

EDS0030R

CARRIER COVER

Removal and Installation REMOVAL

1. Remove drain plug and drain gear oil. Refer to [RFD-11, "DRAINING"](#).
2. Remove carrier cover.
 - Disconnect parking brake cable from carrier cover.
 - Disconnect brake tube from carrier cover.

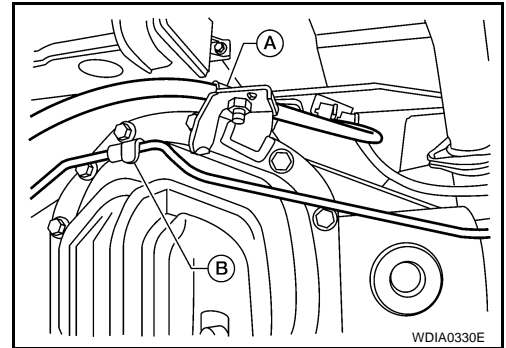

INSTALLATION

1. Apply sealant to mating surface of carrier cover.
 - Use Genuine Silicone RTV or equivalent. Refer to [GI-45, "Recommended Chemical Products and Sealants"](#).

CAUTION:
Remove old sealant adhering to mounting surfaces. Also remove any moisture, oil, or foreign material adhering to application and mounting surfaces.
2. Install carrier cover on axle housing and tighten carrier cover bolts to the specified torque. Refer to [RFD-89, "COMPONENTS"](#).
3. Connect parking brake cable and brake tube to carrier cover.
4. Fill with new gear oil until oil level reaches the specified limit near filler plug mounting hole. Refer to [RFD-11, "Checking Final Drive Oil"](#).

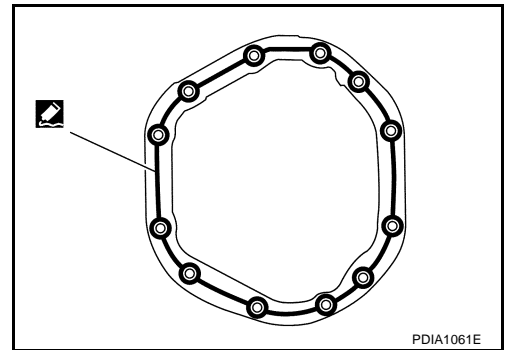

REAR FINAL DRIVE ASSEMBLY [WITH ELECTRONIC LOCKING DIFFERENTIAL]

REAR FINAL DRIVE ASSEMBLY

PFP:38300

Removal and Installation REMOVAL

EDS0030S

CAUTION:

- Do not damage spline, companion flange and front oil seal when removing propeller shaft.
 - Before removing final drive assembly or rear axle assembly, disconnect ABS sensor harness connector from the assembly and move it away from final drive/rear axle assembly area. Failure to do so may result in sensor wires being damaged and sensor becoming inoperative.
1. Drain rear final drive gear oil. Refer to [RFD-11, "DRAINING"](#) .
 2. Remove rear propeller shaft. Refer to [PR-8, "Removal and Installation"](#) .
 - Plug rear end of transfer.
 3. Remove axle shaft. Refer to [RAX-6, "Removal and Installation"](#) .
 4. Support rear final drive using a suitable jack.
 5. Disconnect the following components from rear final drive.
 - Brake tube block connectors. Refer to [BR-13, "Removal and Installation of Rear Brake Piping and Brake Hose"](#) .
 - ABS sensor wire harness. Refer to [BRC-39, "Removal and Installation"](#) .
 - Parking brake cable.
 - Brake tube.

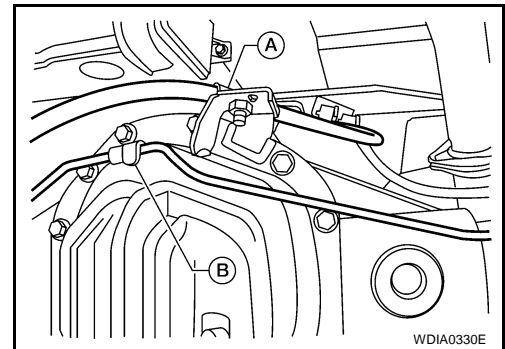

- Differential lock position switch harness connector.
- Differential lock solenoid harness connector.

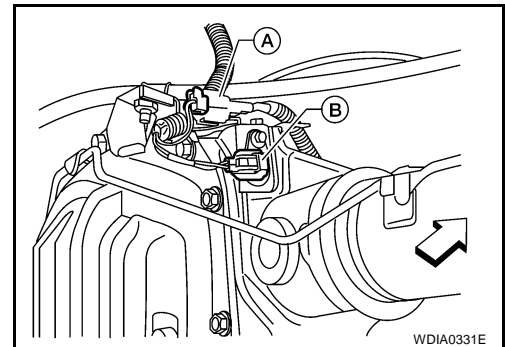

6. Disconnect brake hose from brake tube at the clip on top of axle housing. Then remove the metal clip to disconnect brake line from the clip on top of axle housing.
7. Remove rear shock absorber lower bolts. Refer to [RSU-7, "Removal and Installation"](#) .
8. Remove leaf spring U-bolt nuts. Refer to [RSU-8, "Removal and Installation"](#) .
9. Remove rear final drive assembly.

REAR FINAL DRIVE ASSEMBLY [WITH ELECTRONIC LOCKING DIFFERENTIAL]

INSTALLATION

Note the following, and installation is in the reverse order of removal.

- Fill with new gear oil until oil level reaches the specified limit near filler plug hole. Refer to [RFD-11, "Checking Final Drive Oil"](#).
- Bleed the air from brake system. Refer to [BR-11, "Bleeding Brake System"](#).

Disassembly and Assembly COMPONENTS

EDS0030T

SEC. 380

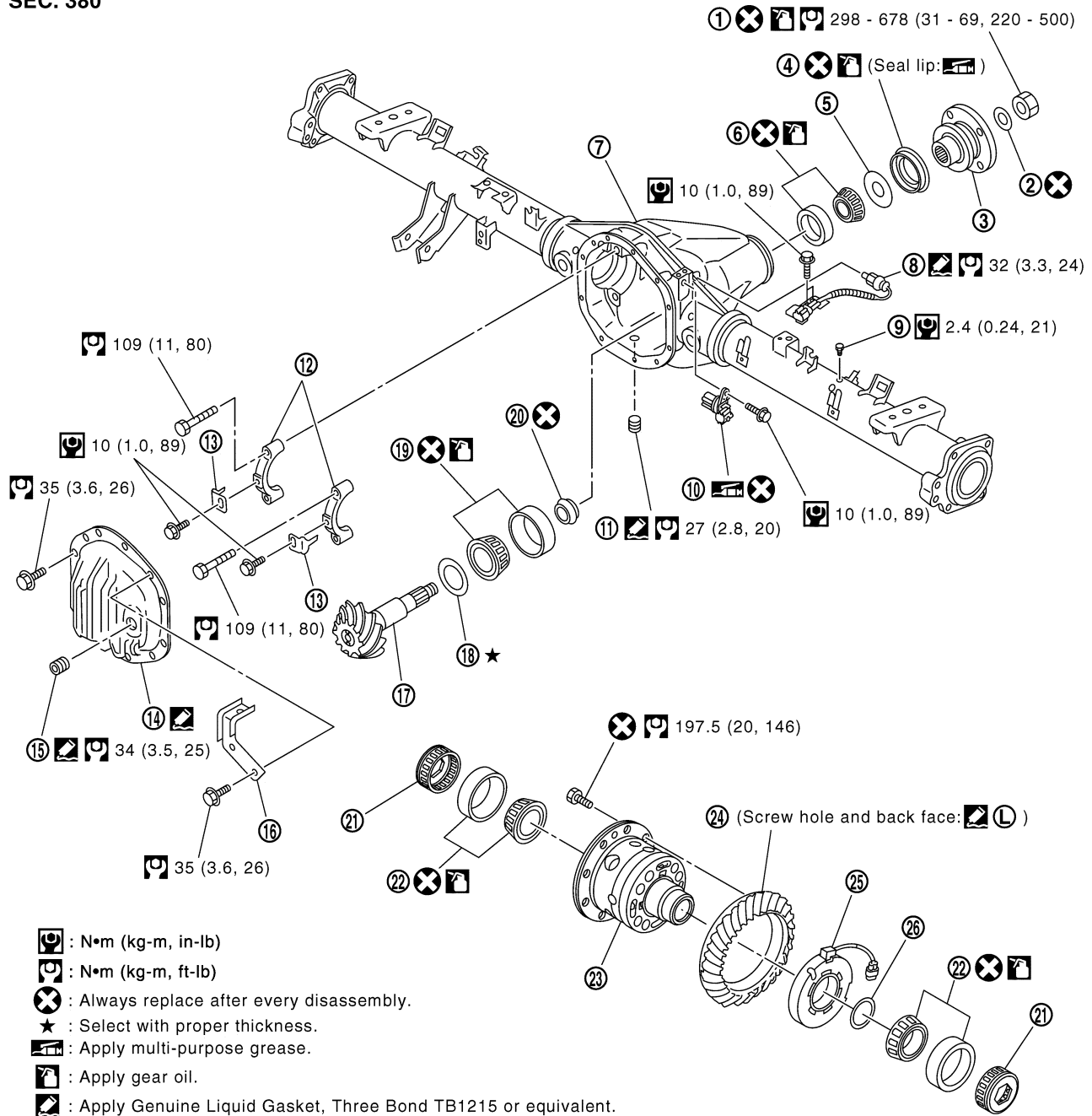

PDIA1064E

- | | | |
|-------------------------|--------------------------------------|--|
| 1. Drive pinion nut | 2. Drive pinion nut washer | 3. Companion flange |
| 4. Front oil seal | 5. Front bearing thrust washer | 6. Drive pinion front bearing |
| 7. Axle housing | 8. Differential lock position switch | 9. Breather |
| 10. Sensor connector | 11. Drain plug | 12. Side bearing cap |
| 13. Adjuster lock plate | 14. Carrier cover | 15. Filler plug |
| 16. Bracket | 17. Drive pinion | 18. Drive pinion height adjusting washer |

A
B
C
RFD
E
F
G
H
I
J
K
L
M

REAR FINAL DRIVE ASSEMBLY [WITH ELECTRONIC LOCKING DIFFERENTIAL]

- | | | |
|--------------------------------|--------------------------------|---------------------------|
| 19. Drive pinion rear bearing | 20. Collapsible spacer | 21. Side bearing adjuster |
| 22. Side bearing | 23. Differential case assembly | 24. Drive gear |
| 25. Differential lock solenoid | 26. Solenoid washer | |

ASSEMBLY INSPECTION AND ADJUSTMENT

Total Preload Torque

1. Turn drive pinion in both directions several times to set bearing rollers.
2. Check total preload using preload gauge set.

Tool number : ST3127S000 (J-25765-A)

Total preload (with oil seal)

2.38 - 5.16 N·m (0.25 - 0.52 kg·m, 21 - 45 in·lb)

NOTE:

Total preload torque = Pinion bearing torque + Side bearing torque

- If measured value is out of the specification, disassemble it to check and adjust each part. Adjust the pinion bearing preload and the side bearing preload. Adjust the pinion bearing preload first, then adjust the side bearing preload.

When the preload torque is large

On pinion bearings: Replace collapsible spacer.

On side bearings: Loosen side bearing adjuster.

When the preload is small

On pinion bearings: Tighten drive pinion nut.

On side bearings: Tighten side bearing adjuster.

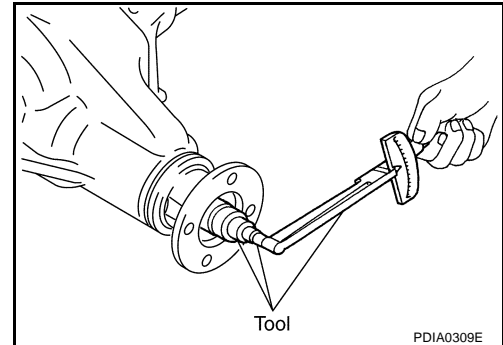

Tooth Contact

Checking gear tooth contact pattern is necessary to verify correct relationship between drive gear and drive pinion. Gears which are not positioned in proper arrangement may be noisy and/or have a short life. Check gear tooth contact pattern to obtain the best contact for low noise and long life.

1. Remove rear cover. Refer to [RFD-93, "DISASSEMBLY"](#).
2. Thoroughly clean drive gear and drive pinion teeth.
3. Apply red lead to drive gear.

CAUTION:

Apply red lead to both the faces of 3 to 4 gears at 4 locations evenly spaced on drive gear.

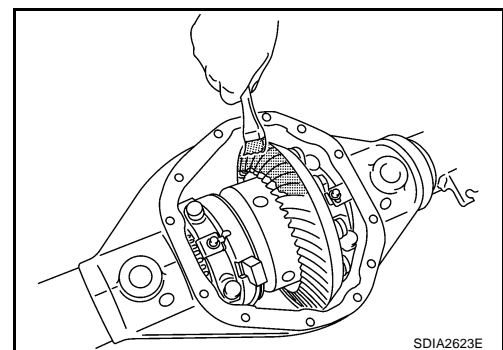

4. Hold companion flange steady by hand and rotate drive gear in both directions.

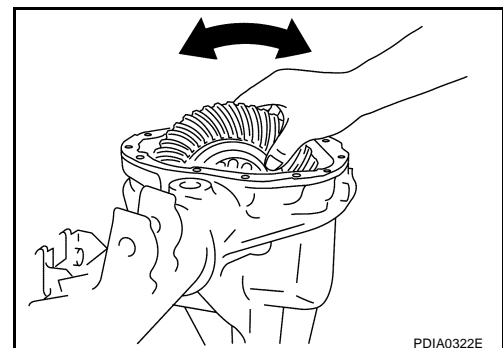

REAR FINAL DRIVE ASSEMBLY [WITH ELECTRONIC LOCKING DIFFERENTIAL]

Usually the pattern will be correct if washers are correctly calculated and the backlash is correct. However, in rare cases, trial and error processes may be employed to obtain a correct pattern. The tooth pattern is the best indication of how well a differential has been set up.

Heel contact

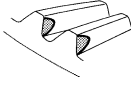

Face contact

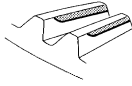

Toe contact

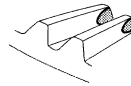

Flank contact

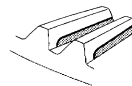

To correct, increase thickness of drive pinion height adjusting washer in order to bring drive pinion close to drive gear.

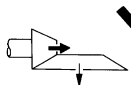

To correct, reduce thickness of drive pinion height adjusting washer in order to make drive pinion go away from drive gear.

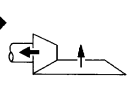

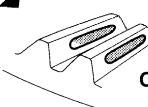

Correct tooth contact

When adjustment is completed, be sure to wipe off completely the red lead and oil or their equivalent. SDIA2591E

5. If outside the standard, adjust drive pinion height adjusting washer and backlash. Refer to [RFD-98, "Drive Pinion Height Adjusting Washer"](#) , [RFD-91, "Backlash"](#) .

Backlash

1. Remove rear cover. Refer to [RFD-93, "DISASSEMBLY"](#) .
2. Check drive gear to drive pinion backlash using a dial indicator at several points.

Drive gear to drive pinion backlash
: 0.08 - 0.13 mm (0.0031 - 0.0051 in)

3. If outside the standard, adjust side bearing adjuster.

CAUTION:

Check tooth contact and total preload after adjusting side bearing adjuster. Refer to [RFD-90, "Total Preload Torque"](#) , [RFD-90, "Tooth Contact"](#) .

- a. Remove adjuster lock plate.
- b. Loosen side bearing cap bolts.
- c. Tighten or loosen each side bearing adjusters using Tool.

Tool number : — (C - 4164)

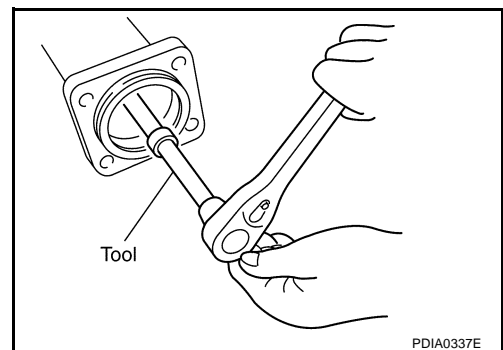
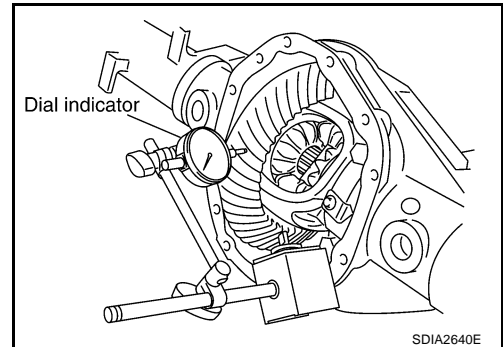

REAR FINAL DRIVE ASSEMBLY [WITH ELECTRONIC LOCKING DIFFERENTIAL]

- d. In case of lots of backlash, loosen side bearing adjuster A and tighten side bearing adjuster B. In case of less backlash, loosen side bearing adjuster B and tighten side bearing adjuster A.

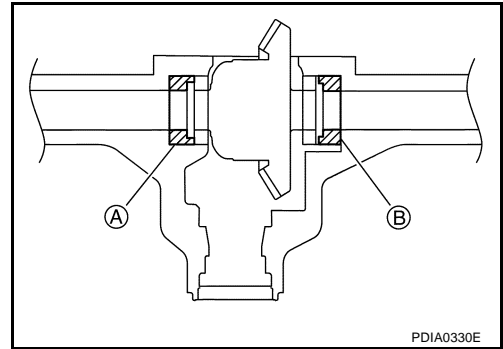

- e. After adjusting backlash and tighten cap bolts to the specified torque. Refer to [RFD-89, "COMPONENTS"](#) .
- f. Install adjuster lock plate and tighten to the specified torque. Refer to [RFD-89, "COMPONENTS"](#) .

CAUTION:

Install adjuster lock plate to grooving of differential lock solenoid.

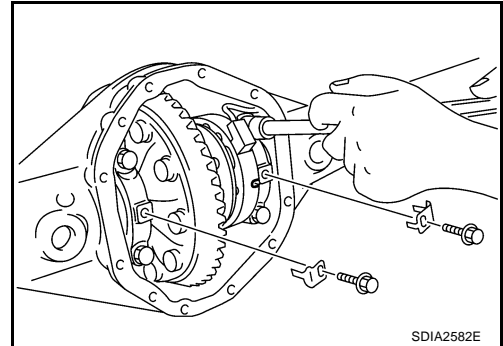

Companion Flange Runout

1. Fit a dial indicator onto companion flange face (inner side of propeller shaft bolt holes).
2. Rotate companion flange to check for runout.

Runout limit : 0.10 mm (0.0039 in) or less

3. Fit a test indicator to the inner side of companion flange (socket diameter).
4. Rotate companion flange to check for runout.

Runout limit : 0.13 mm (0.0051 in) or less

5. If the runout value is outside the repair limit, follow the procedure below to adjust.

- a. Check for runout while changing the phase between companion flange and drive pinion by 90° step, and search for the point where the runout is the minimum.
- b. If the runout value is still outside of the limit after the phase has been changed, replace companion flange.
- c. If the runout value still outside of the limit after companion flange has been replaced, check drive pinion bearing and drive pinion assembly.

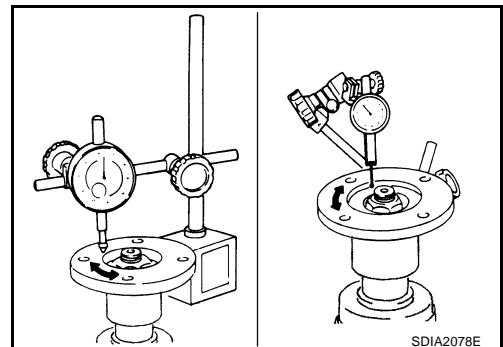

REAR FINAL DRIVE ASSEMBLY [WITH ELECTRONIC LOCKING DIFFERENTIAL]

DISASSEMBLY

Differential Assembly

1. Remove carrier cover bolts.
2. Remove carrier cover using Tool.

Tool number : KV10111100 (J-37228)

CAUTION:

- Do not damage the mating surface.
- Do not insert flat-bladed screwdriver, this will damage the mating surface.

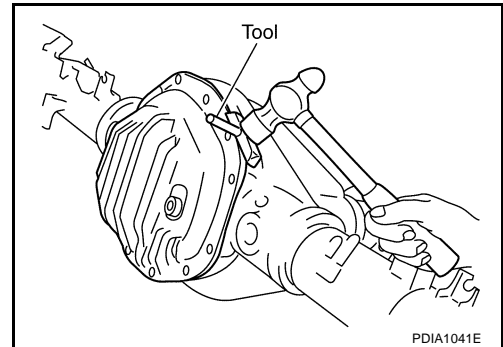

3. Remove differential sensor connector bolts and differential lock solenoid connector.

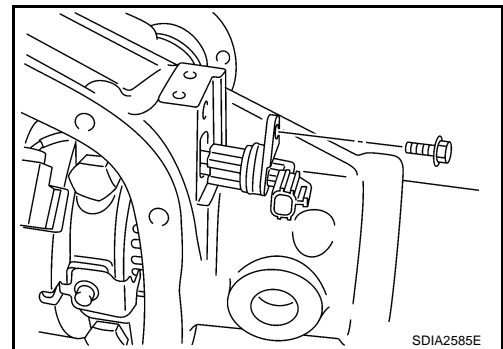

4. For proper reinstallation, paint matching mark on one side of side bearing cap.

CAUTION:

- Side bearing caps are line-board for initial assembly. The matching marks are used to reinstall them in their original positions.
- For matching mark, use paint. Do not damage side bearing cap.

5. Remove adjuster lock plates.

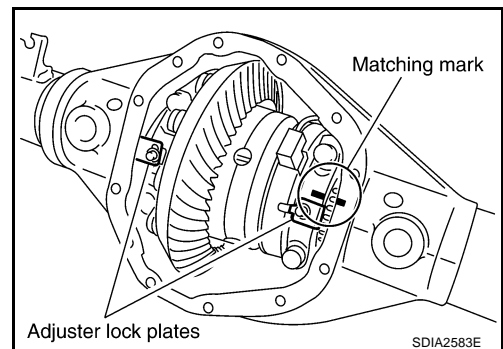

6. Remove side bearing caps.

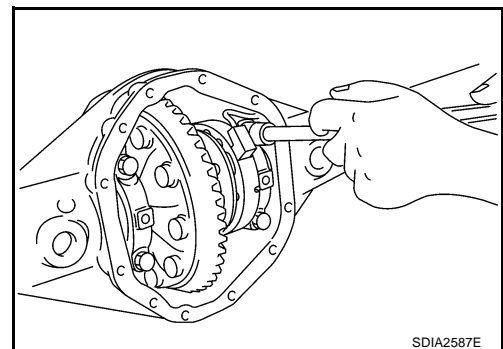

A
B
C
RFD
E
F
G
H
I
J
K
L
M

REAR FINAL DRIVE ASSEMBLY [WITH ELECTRONIC LOCKING DIFFERENTIAL]

7. Remove side bearing adjusters using Tool.

Tool number : — (C - 4164)

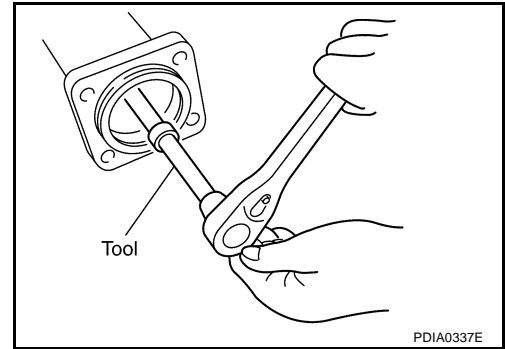

8. Keep side bearing outer races together with inner races. Do not mix them up. Also, keep side bearing adjusters together with bearing.
9. Remove side bearing adjusters from axle housing.

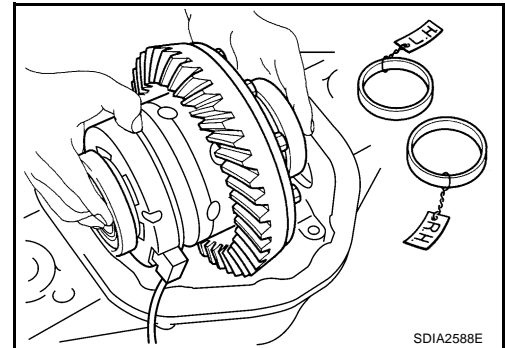

10. Remove bracket of differential lock position switch connector and bolts.
11. Remove differential lock position switch.
12. Remove side bearing inner race and washer using Tool.

Tool number : ST33081000 (—)

CAUTION:

Do not damage differential case assembly and differential lock solenoid.

13. Remove differential lock solenoid and solenoid washer.

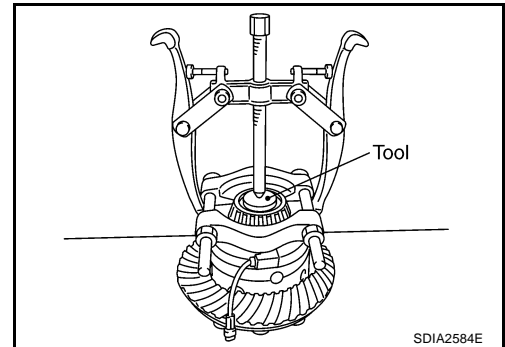

14. Remove side bearing inner race using Tool.

Tool number : ST33081000 (—)

CAUTION:

Do not damage differential case assembly.

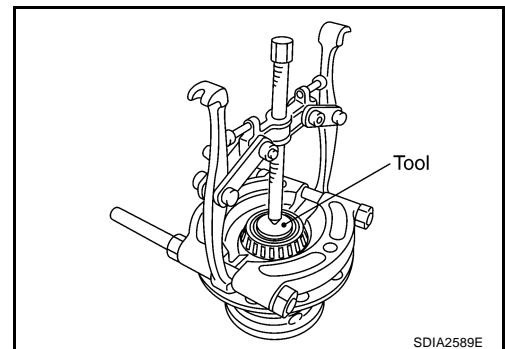

REAR FINAL DRIVE ASSEMBLY [WITH ELECTRONIC LOCKING DIFFERENTIAL]

15. For proper reinstallation, paint matching mark on differential case assembly and drive gear.

CAUTION:

For matching mark, use paint. Do not damage differential case and drive gear.

16. Remove drive gear bolts.

17. Tap drive gear off differential case assembly with a soft hammer.

CAUTION:

Tap evenly all around to keep drive gear from binding.

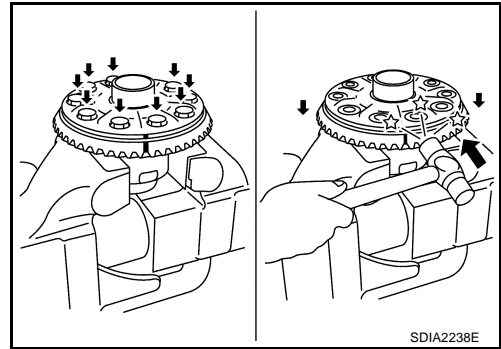

SDIA2238E

Drive Pinion Assembly

1. Remove differential case assembly. Refer to [RFD-93, "Differential Assembly"](#).
2. Remove drive pinion nut and washer using Tool.

Tool number : KV40104000 (—)

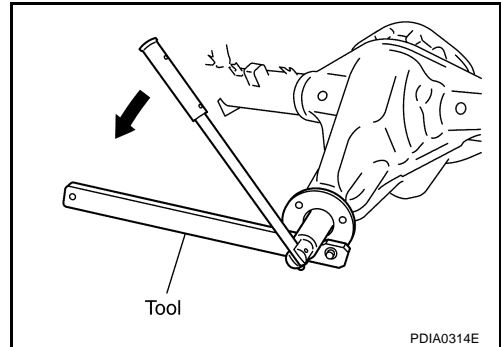

Tool

PDIA0314E

3. Put a matching mark on the thread edge of drive pinion. The mark should be in line with the mark on companion flange.

CAUTION:

For matching mark, use paint. Do not damage drive pinion.

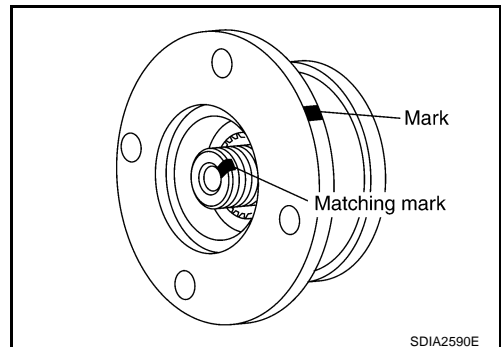

SDIA2590E

4. Remove companion flange using a suitable tool.

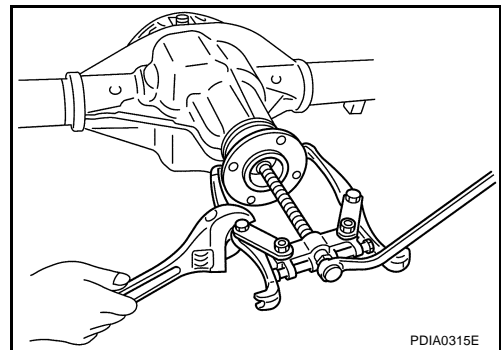

PDIA0315E

A
B
C
RFD

E
F
G
H
I
J
K
L
M

REAR FINAL DRIVE ASSEMBLY [WITH ELECTRONIC LOCKING DIFFERENTIAL]

5. Remove front oil seal using Tool.

Tool number : ST33290001 (J-34286)

CAUTION:

Do not damage axle housing.

6. Remove front bearing thrust washer.

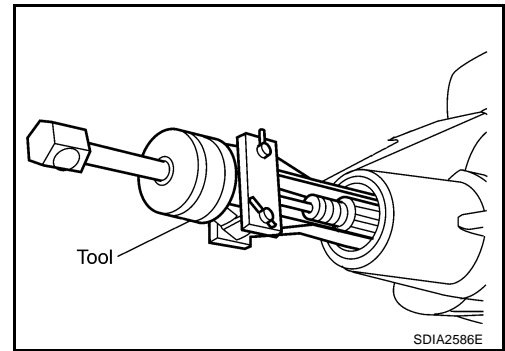

7. Remove drive pinion assembly and collapsible spacer from axle housing using suitable press.

CAUTION:

Do not drop drive pinion assembly.

8. Remove drive pinion front bearing inner race from axle housing.

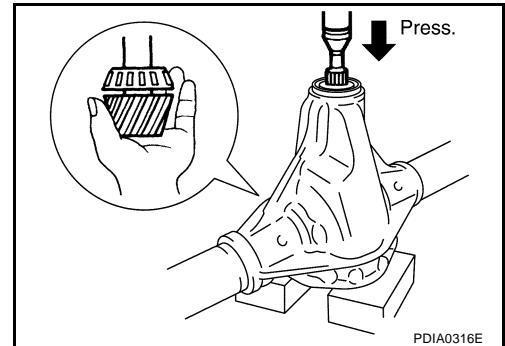

9. Tap drive pinion front bearing outer race uniformly with a brass bar or equivalent to remove.

CAUTION:

Do not damage axle housing.

10. Tap drive pinion rear bearing outer race uniformly with a brass bar or equivalent for removal.

CAUTION:

Do not damage axle housing.

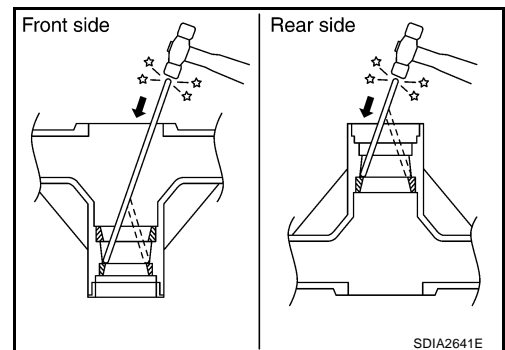

11. Remove drive pinion rear bearing inner race and drive pinion height adjusting washer using Tool.

Tool number : ST30021000 (J-22912-01)

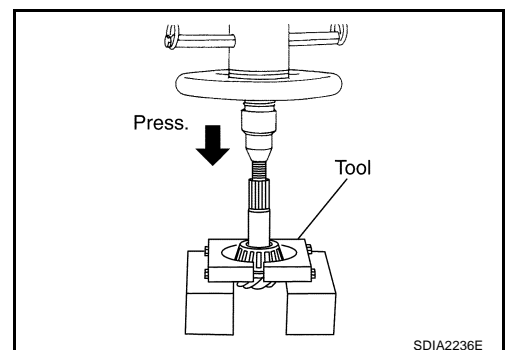

REAR FINAL DRIVE ASSEMBLY

[WITH ELECTRONIC LOCKING DIFFERENTIAL]

INSPECTION AFTER DISASSEMBLY

Drive Gear and Drive Pinion

- If the gear teeth do not mesh or line-up correctly, determine the cause and adjust, repair, or replace as necessary.
- If the gears are worn, cracked, damaged, pitted or chipped (by friction) noticeably, replace with new gears.
- Drive gear and drive pinion are supplied in matched sets only. Matching numbers on both drive pinion and drive gear are etched for verification. If a new gear set is being used, verify the numbers of each pinion gear and drive gear before proceeding with assembly.

Bearing

- If found any chipped (by friction), pitted, worn, rusted, scratched mark, or unusual noise from the bearing, replace with new bearing assembly (as a new set).
- Bearing must be replaced with a new one whenever disassembled.

Differential Case Assembly

- If the gears are worn, cracked, damaged, pitted or chipped (by friction) noticeably, replace with new differential case assembly.
- If the movement is not smooth when pushing cam ring of differential case assembly with a hand.

Differential Lock Solenoid

- If the operating part of differential lock solenoid is not smooth, perform component inspection. Refer to [RFD-72, "COMPONENT INSPECTION"](#).

A

B

C

RFD

E

F

G

H

I

J

K

L

M

REAR FINAL DRIVE ASSEMBLY [WITH ELECTRONIC LOCKING DIFFERENTIAL]

SELECTION ADJUSTING WASHERS

Drive Pinion Height Adjusting Washer

- Drive gear and drive pinion are supplied in matched sets only. Matching numbers on both drive pinion and drive gear are etched for verification. If a new gear set is being used, verify the numbers of each drive pinion and drive gear before proceeding with assembly.

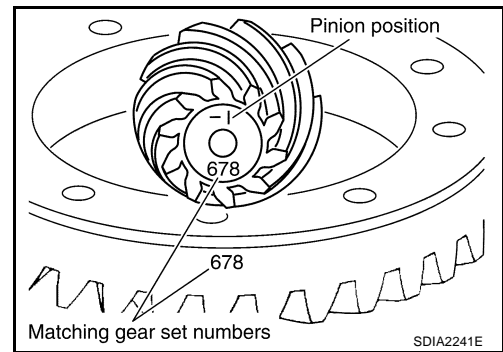

- The mounting distance from the center line of drive gear to the back face of drive pinion for the Model 226 axle assembly is 109.5 mm (4.312 in).
On the button end of each drive pinion, there is etched a plus (+) number, a minus (-) number, or a zero (0), which indicates the best running position for each particular gear set. This dimension is controlled by a selective drive pinion height adjusting washer between drive pinion inner bearing race and drive pinion. For example: If a drive pinion is etched m+8 (+3), it would require 0.08 mm (0.003 in) less drive pinion height adjusting washer than a drive pinion etched "0". This means decreasing drive pinion height adjusting washer thickness; increases the mounting distance of drive pinion to 109.6 mm (4.315 in). If a drive pinion is etched m-8 (-3), it would require adding 0.08 mm (0.003 in) more to drive pinion height adjusting washer than would be required if drive pinion were etched "0". By adding 0.08 mm (0.003 in), the mounting distance of drive pinion was decreased to 109.4 mm (4.309 in) which is just what m-8 (a-3) etching indicated.
- To change drive pinion adjustment, use different drive pinion height adjusting washers which come in different thickness.
- Use the following tables as a guide for selecting the correct drive pinion height adjusting washer thickness to add or subtract from the old drive pinion height adjusting washer.

OLD DRIVE PINION MARKING	NEW DRIVE PINION MARKING mm (in)								
	-4	-3	-2	-1	0	+1	+2	+3	+4
+4	+0.20 (+0.008)	+0.18 (+0.007)	+0.15 (+0.006)	+0.13 (+0.005)	+0.10 (+0.004)	+0.08 (+0.003)	+0.05 (+0.002)	+0.02 (+0.001)	0 (0)
+3	+0.18 (+0.007)	+0.15 (+0.006)	+0.13 (+0.005)	+0.10 (+0.004)	+0.08 (+0.003)	+0.05 (+0.002)	+0.02 (+0.001)	0 (0)	-0.02 (-0.001)
+2	+0.15 (+0.006)	+0.13 (+0.005)	+0.10 (+0.004)	+0.08 (+0.003)	+0.05 (+0.002)	+0.02 (+0.001)	0 (0)	-0.02 (-0.001)	-0.05 (-0.002)
+1	+0.13 (+0.005)	+0.10 (+0.004)	+0.08 (+0.003)	+0.05 (+0.002)	+0.02 (+0.001)	0 (0)	-0.02 (-0.001)	-0.05 (-0.002)	-0.08 (-0.003)
0	+0.10 (+0.004)	+0.08 (+0.003)	+0.05 (+0.002)	+0.02 (+0.001)	0 (0)	-0.02 (-0.001)	-0.05 (-0.002)	-0.08 (-0.003)	-0.10 (-0.004)
-1	+0.08 (+0.003)	+0.05 (+0.002)	+0.02 (+0.001)	0 (0)	-0.02 (-0.001)	-0.05 (-0.002)	-0.08 (-0.003)	-0.10 (-0.004)	-0.13 (-0.005)
-2	+0.05 (+0.002)	+0.02 (+0.001)	0 (0)	-0.02 (-0.001)	-0.05 (-0.002)	-0.08 (-0.003)	-0.10 (-0.004)	-0.13 (-0.005)	-0.15 (-0.006)
-3	+0.02 (+0.001)	0 (0)	-0.02 (-0.001)	-0.05 (-0.002)	-0.08 (-0.003)	-0.10 (-0.004)	-0.13 (-0.005)	-0.15 (-0.006)	-0.18 (-0.007)
-4	0 (0)	-0.02 (-0.001)	-0.05 (-0.002)	-0.08 (-0.003)	-0.10 (-0.004)	-0.13 (-0.005)	-0.15 (-0.006)	-0.18 (-0.007)	-0.20 (-0.008)

REAR FINAL DRIVE ASSEMBLY [WITH ELECTRONIC LOCKING DIFFERENTIAL]

1. Make sure all parts are clean and that drive pinion bearings are well lubricated.
2. Assemble drive pinion bearings into the tools.

Tool number	A: — (8144)
	B: — (6740)
	C: — (6741)

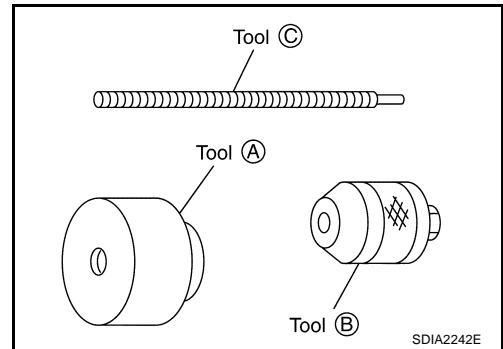

3. Install drive pinion bearing inner race and drive pinion height adjusting washer to axle housing using tool as shown.

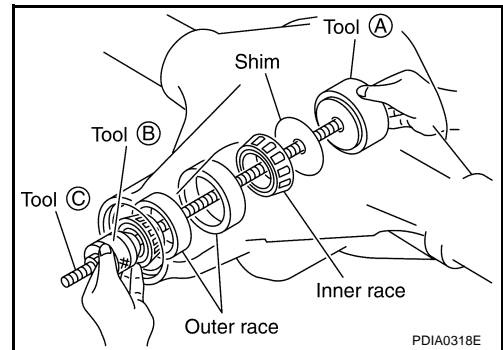

4. Turn the assembly several times to seat drive pinion bearings.

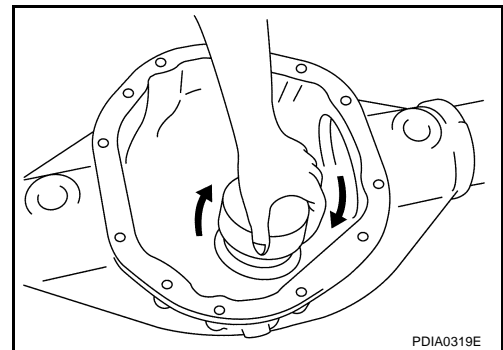

5. Measure the turning torque using Tool.

Tool number : ST3127S000 (J-25765-A)

Turning torque specification

: 1.2 - 2.8 N-m (0.13 - 0.28 kg-m, 11 - 24 in-lb)

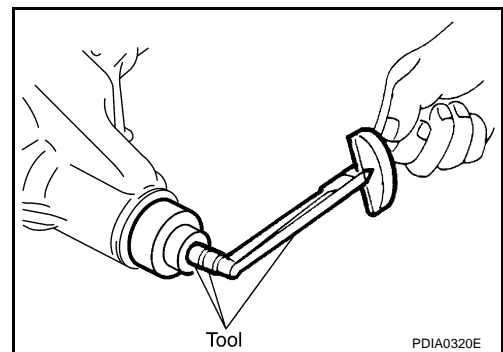

6. Tighten side bearing caps to the specified torque installing tools as shown.

Tool number	A: — (6739)
	B: — (D-115-2)
	C: — TBD
	D: — (D-115-3)

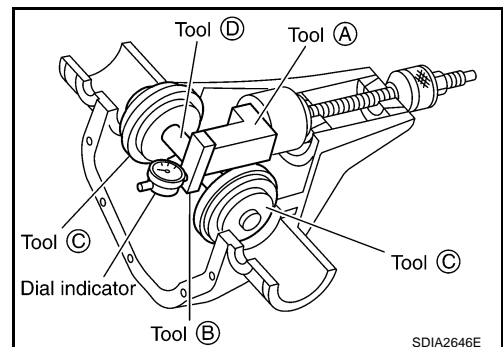

A
B
C
RFD
E
F
G
H
I
J
K
L
M

REAR FINAL DRIVE ASSEMBLY [WITH ELECTRONIC LOCKING DIFFERENTIAL]

7. Put scooter block on pinion height block. Make sure that dial indicator is level adjusting pressure with a hand. Dial indicator indicates "0".
8. Slide dial indicator along arbor. Record the maximum.
9. Adjust drive pinion height adjusting washer so that the maximum will be "0".

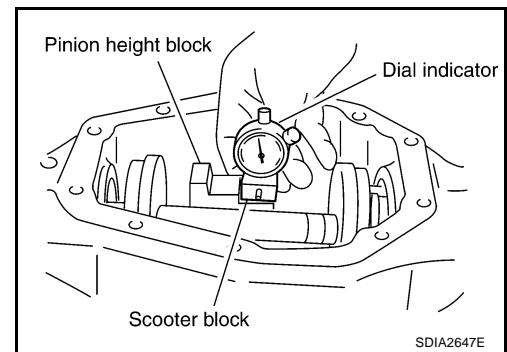

ASSEMBLY

Drive Pinion Assembly

1. Press a drive pinion rear bearing outer race into axle housing using Tool.

Tool number **A: ST01500001 (—)**
 B: ST30022000 (—)

CAUTION:
Do not reuse drive pinion rear bearing.

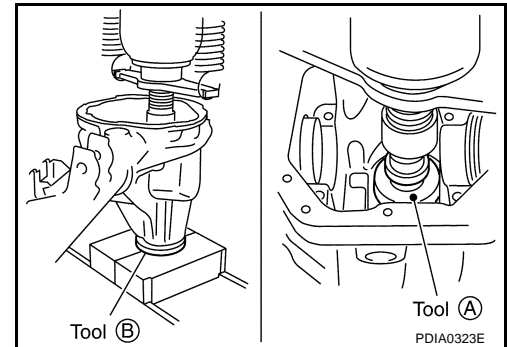

2. Press a drive pinion front bearing outer race into axle housing using Tool.

Tool number : **ST33022000 (—)**

CAUTION:
Do not reuse drive pinion front bearing.

3. Select drive pinion height adjusting washer. Refer to [RFD-98, "Drive Pinion Height Adjusting Washer"](#) .

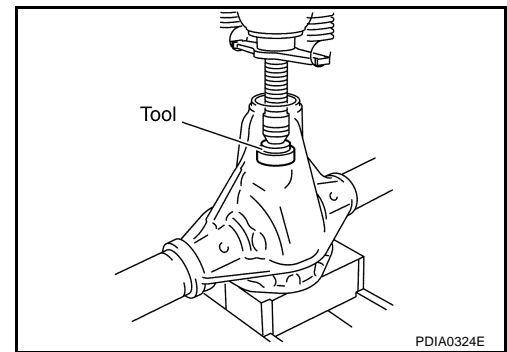

4. Press a drive pinion rear bearing inner race and drive pinion height adjusting washer to drive pinion using Tool.

Tool number : — **(C - 4040)**

CAUTION:
Do not reuse drive pinion rear bearing.

5. Apply gear oil to drive pinion rear bearing and drive pinion front bearing.
6. Install drive pinion front bearing inner race in axle housing.
7. Install front bearing thrust washer to axle housing.

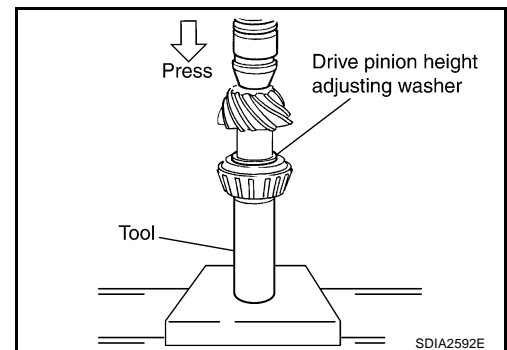

REAR FINAL DRIVE ASSEMBLY [WITH ELECTRONIC LOCKING DIFFERENTIAL]

8. Apply multi-purpose grease to front oil seal lip. Install front oil seal into axle housing using Tool.

Tool number : ST15310000 (—)

CAUTION:

- Do not reuse oil seal.
- When installing, do not incline oil seal.

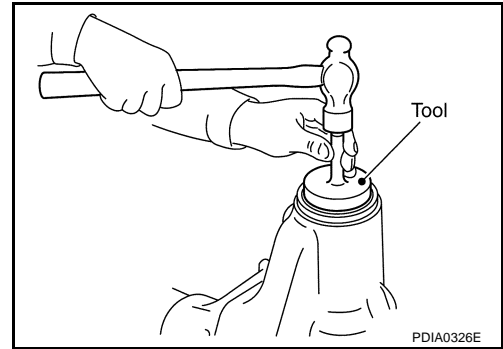

9. Install collapsible spacer to drive pinion. And then install drive pinion assembly in axle housing.

CAUTION:

- Do not reuse collapsible spacer.
- Do not damage front oil seal.

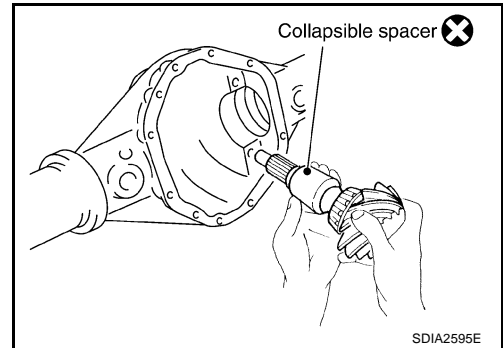

10. Align the matching mark of drive pinion with the mark of companion flange.

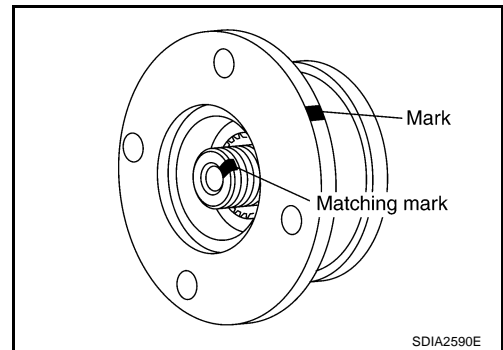

11. Install companion flange onto drive pinion. Tap companion flange with a soft hammer until fully seated.

CAUTION:

Do not damage companion flange and front oil seal.

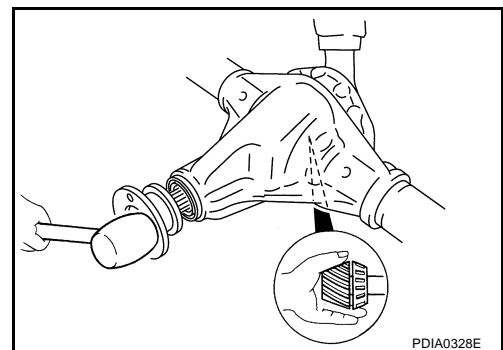

12. Install drive pinion nut and drive pinion nut washer. Tighten drive pinion nut until total preload is within specification.

- The threaded portion of drive pinion and drive pinion nut should be free from oil or grease.

Tool number : KV40104000 (—)

CAUTION:

Do not reuse drive pinion nut and drive pinion nut washer.

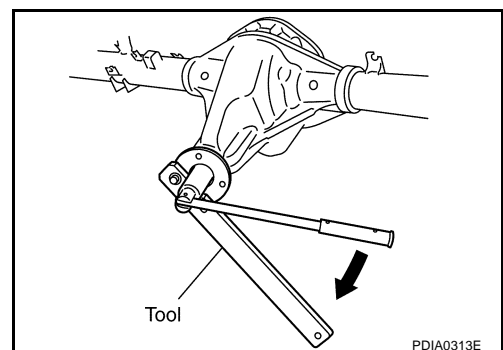

A
B
C
RFD

E
F
G
H
I
J
K
L
M

REAR FINAL DRIVE ASSEMBLY [WITH ELECTRONIC LOCKING DIFFERENTIAL]

13. Tighten drive pinion nut by very small degrees until the specified preload is achieved. When checking the preload, turn drive pinion in both directions several times to set the bearing rollers using Tool.

Tool number : ST3127S000 (J-25765-A)

Pinion bearing preload:

1.7 - 3.8 N·m (0.18 - 0.38 kg-m, 15 - 33 in-lb)

- a. This procedure will have to be repeated if:
- Maximum preload is achieved before the minimum drive pinion nut torque is reached.
 - Minimum preload is not achieved before maximum drive pinion nut torque is reached.

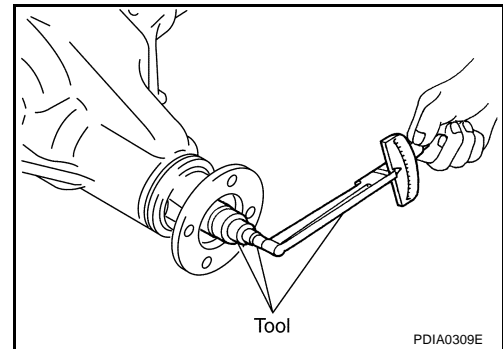

Differential Assembly

1. Align the matching mark of differential case assembly with the mark of drive gear, then install drive gear.

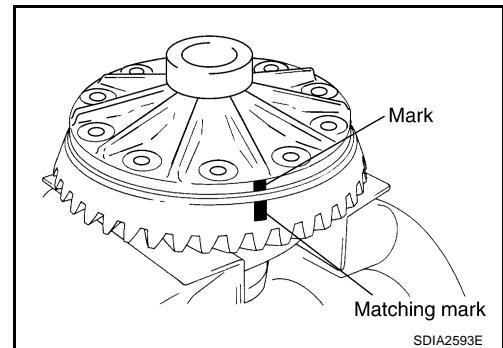

2. Apply thread locking sealant into the thread hole of drive gear.
- Use **Genuine Medium Strength Thread Locking Sealant or equivalent**. Refer to [GI-45, "Recommended Chemical Products and Sealants"](#) .

CAUTION:

The drive gear back and threaded holes shall be cleaned and decreased sufficiently.

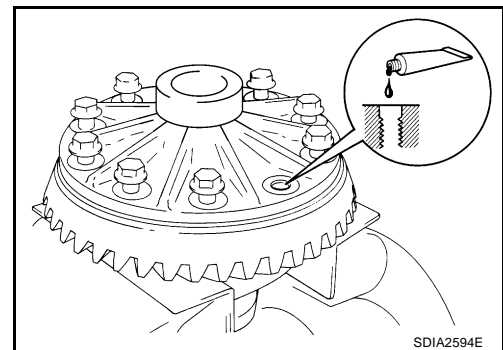

3. Install drive gear on the bolts, and then tighten to the specified torque. Refer to [RFD-89, "COMPONENTS"](#) .

CAUTION:

- **Do not reuse the bolts.**
- **Tighten bolts in a crisscross fashion.**

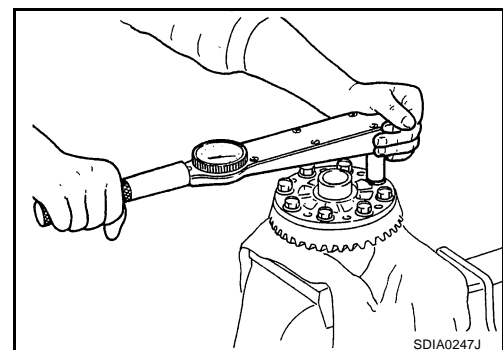

REAR FINAL DRIVE ASSEMBLY [WITH ELECTRONIC LOCKING DIFFERENTIAL]

4. Press side bearing inner races to differential case assembly using Tool.

Tool number : ST33081000 (—)

CAUTION:

Do not reuse side bearing.

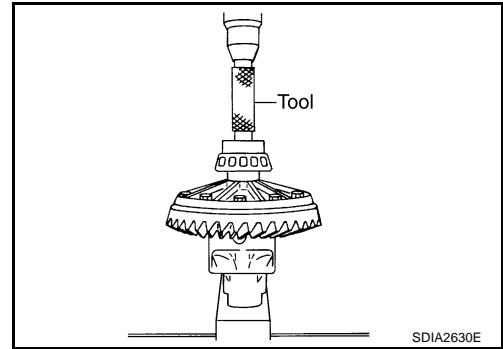

5. Install differential lock solenoid and washer.
6. Press side bearing inner races to differential case assembly using Tool.

Tool number **A:** KV38100300 (J-25523)
 B: ST33081000 (—)

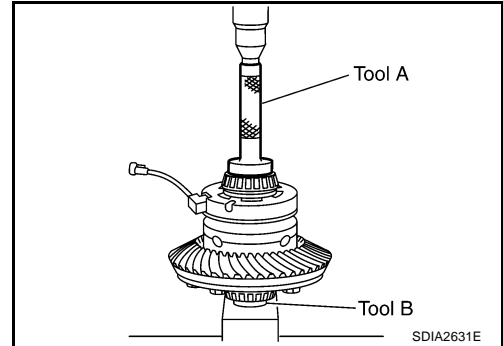

7. Apply sealant to threads of differential lock position switch.

- **Use Genuine Silicone RTV or equivalent. Refer to [GI-45, "Recommended Chemical Products and Sealants"](#).**

CAUTION:

Remove old sealant adhering to axle housing and differential lock position switch. Also remove any moisture, oil, or foreign material adhering to application and axle housing and differential lock position switch.

8. Install differential lock position switch on axle housing and tighten differential lock position switch bolts with the specified torque. Refer to [RFD-89, "COMPONENTS"](#).

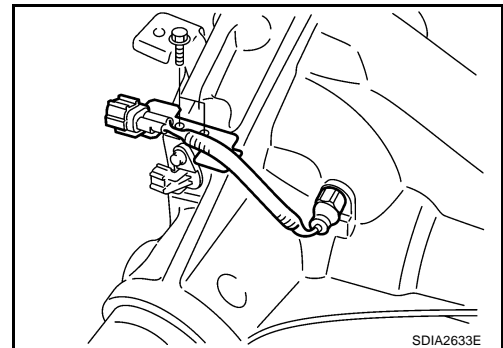

9. Install side bearing adjusters into axle housing.

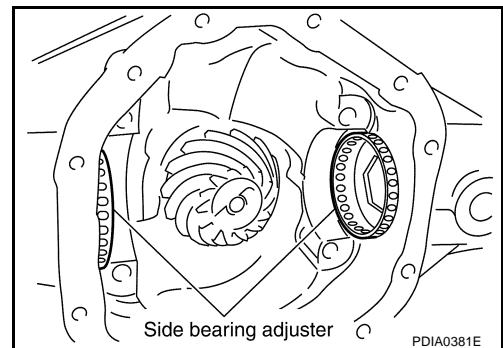

A
B
C
RFD
E
F
G
H
I
J
K
L
M

REAR FINAL DRIVE ASSEMBLY [WITH ELECTRONIC LOCKING DIFFERENTIAL]

10. Apply gear oil to side bearings. Install differential case assembly with side bearing outer races into axle housing.
11. Apply multi-purpose grease to sensor connector.

CAUTION:

Do not reuse sensor connector.

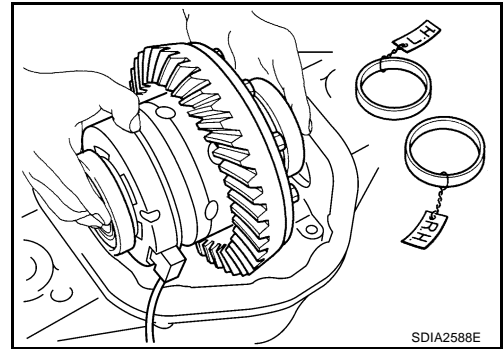

12. Connect differential lock solenoid harness and sensor connector. Then install it to axle housing, tighten to the specified torque. Refer to [RFD-89, "COMPONENTS"](#).

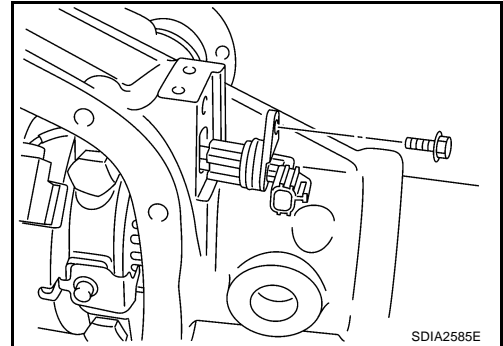

13. Align paint matching mark on side bearing caps with that on axle housing and install side bearing caps on axle housing.

CAUTION:

Do not tighten at this point. This allows further tightening of side bearing adjusters.

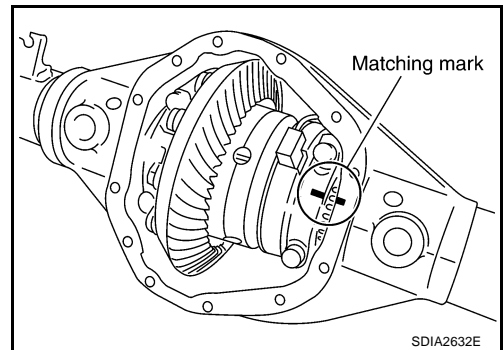

14. Tighten each side bearing adjusters using adjuster tool.

Tool number : — (C - 4164)

15. Adjusting backlash of drive gear and drive pinion. Refer to [RFD-91, "Backlash"](#).
16. Check total preload. Refer to [RFD-90, "Total Preload Torque"](#).
17. Check tooth contact. Refer to [RFD-90, "Tooth Contact"](#).

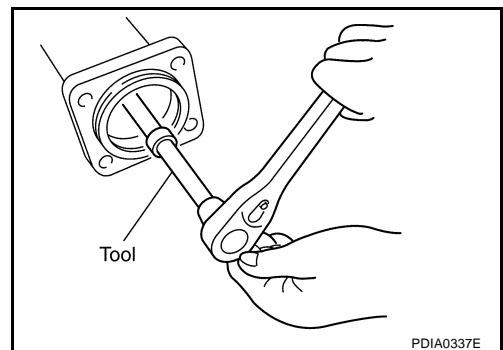

18. Apply sealant to mating surface of carrier cover.

- Use Genuine Silicone RTV or equivalent. Refer to [GI-45, "Recommended Chemical Products and Sealants"](#).

CAUTION:

Remove old sealant adhering to mating surfaces. Also remove any moisture, oil, or foreign material adhering to application and mating surfaces.

19. Install carrier cover on axle housing and tighten carrier cover bolts with the specified torque. Refer to [RFD-89, "COMPONENTS"](#).

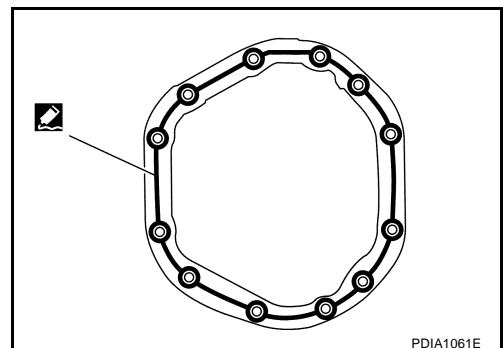

**SERVICE DATA AND SPECIFICATIONS (SDS)
[WITH ELECTRONIC LOCKING DIFFERENTIAL]**

SERVICE DATA AND SPECIFICATIONS (SDS)

PF0:00030

General Specifications

EDS0030U

Engine	VK56DE
Transmission	5A/T
Final drive model	M226
Gear ratio	3.357
Number of pinion gears	2
Number of teeth (Drive gear / drive pinion)	47/14
Oil capacity (Approx.) ℓ (US pt, Imp pt)	2.01 (4-1/4, 3-1/2)
Drive pinion adjustment spacer type	Collapsible

A

B

C

RFD

**Inspection and Adjustment
PRELOAD TORQUE**

EDS0030V

Unit: N·m (kg·m, in·lb)

Item	Specification
Total preload (Drive pinion torque to rotate plus)	2.38 - 5.16 (0.25 - 0.52, 21 - 45)
Drive pinion bearing preload	1.7 - 3.8 (0.18 - 0.38, 15 - 33)

E

F

G

BACKLASH

Unit: mm (in)

Item	Standard
Drive gear to drive pinion gear	0.08 - 0.13 (0.0031 - 0.0051)

H

COMPANION FLANGE RUNOUT

Unit: mm (in)

Item	Runout limit
Companion flange face	0.10 (0.0039) or less
Inner side of companion flange	0.13 (0.0051) or less

I

J

K

L

M

SERVICE DATA AND SPECIFICATIONS (SDS)
[WITH ELECTRONIC LOCKING DIFFERENTIAL]

SELECTIVE PARTS

Drive Pinion Height Adjusting Washer

Unit: mm (in)

Thickness	Package part number*
0.076 (0.030) 0.079 (0.031) 0.081 (0.032) 0.084 (0.033) 0.086 (0.034)	38151 8S101
0.089 (0.035) 0.091 (0.036) 0.094 (0.037) 0.097 (0.038) 0.099 (0.039)	38151 8S102
0.102 (0.040) 0.104 (0.041) 0.107 (0.042) 0.109 (0.043) 0.112 (0.044)	38151 8S103
0.114 (0.045) 0.117 (0.046) 0.119 (0.047) 0.122 (0.048) 0.124 (0.049)	38151 8S104
0.127 (0.050) 0.130 (0.051) 0.132 (0.052) 0.135 (0.053) 0.137 (0.054)	38151 8S105

*Always check with the Parts Department for the latest parts information.