

A
B
C

TF

SECTION

TRANSFER

TF

CONTENTS

<p>PRECAUTIONS 4</p> <p>Precautions for Supplemental Restraint System (SRS) "AIR BAG" and "SEAT BELT PRE-TENSIONER" 4</p> <p>Precautions for Transfer Assembly and Transfer Control Unit Replacement 4</p> <p style="padding-left: 20px;">CHECK 4WD SHIFT INDICATOR PATTERN 4</p> <p style="padding-left: 20px;">METHOD FOR ADJUSTMENT WITH 4WD SHIFT SWITCH AT "2WD" 5</p> <p style="padding-left: 20px;">METHOD FOR ADJUSTMENT WITH 4WD SHIFT SWITCH AT "4H" OR "4LO" 5</p> <p>Precautions 6</p> <p>Service Notice 6</p> <p>Wiring Diagrams and Trouble Diagnosis 7</p> <p>PREPARATION 8</p> <p>Special Service Tools 8</p> <p>Commercial Service Tools 10</p> <p>NOISE, VIBRATION AND HARSHNESS (NVH)</p> <p>TROUBLESHOOTING 11</p> <p>NVH Troubleshooting Chart 11</p> <p>TRANSFER FLUID 12</p> <p>Replacement 12</p> <p style="padding-left: 20px;">DRAINING 12</p> <p style="padding-left: 20px;">FILLING 12</p> <p>Inspection 12</p> <p style="padding-left: 20px;">FLUID LEAKAGE AND FLUID LEVEL 12</p> <p>4WD SYSTEM 13</p> <p>Cross-section View 13</p> <p>Power Transfer 14</p> <p style="padding-left: 20px;">POWER TRANSFER DIAGRAM 14</p> <p style="padding-left: 20px;">POWER TRANSFER FLOW 15</p> <p>System Description 15</p> <p style="padding-left: 20px;">TRANSFER CONTROL DEVICE 15</p> <p style="padding-left: 20px;">WAIT DETECTION SWITCH 15</p> <p style="padding-left: 20px;">4LO SWITCH 15</p> <p style="padding-left: 20px;">ATP SWITCH 15</p> <p style="padding-left: 20px;">TRANSFER CONTROL UNIT 15</p> <p style="padding-left: 20px;">TRANSFER RELAY 15</p> <p style="padding-left: 20px;">4WD SHIFT SWITCH AND INDICATOR LAMP.. 16</p> <p style="padding-left: 20px;">4WD WARNING LAMP 17</p>	<p style="padding-left: 20px;">ATP WARNING LAMP 17</p> <p style="padding-left: 20px;">System Diagram 18</p> <p style="padding-left: 20px;">COMPONENTS FUNCTION 18</p> <p style="padding-left: 20px;">CAN Communication 19</p> <p style="padding-left: 20px;">..... 19</p> <p>TROUBLE DIAGNOSIS 20</p> <p>How to Perform Trouble Diagnosis 20</p> <p style="padding-left: 20px;">BASIC CONCEPT 20</p> <p>Location of Electrical Parts 21</p> <p>Circuit Diagram 22</p> <p>Wiring Diagram — T/F — 23</p> <p>Trouble Diagnosis Chart for Symptoms 27</p> <p>Transfer Control Unit Input/Output Signal Reference Values 27</p> <p style="padding-left: 20px;">TRANSFER CONTROL UNIT INSPECTION</p> <p style="padding-left: 20px;">TABLE 27</p> <p>CONSULT-II Function (ALL MODE AWD/4WD) 31</p> <p style="padding-left: 20px;">FUNCTION 31</p> <p style="padding-left: 20px;">CONSULT-II SETTING PROCEDURE 31</p> <p style="padding-left: 20px;">SELF-DIAG RESULT MODE 33</p> <p style="padding-left: 20px;">DATA MONITOR MODE 34</p> <p>Self-Diagnostic Procedure 36</p> <p style="padding-left: 20px;">SELF-DIAGNOSTIC PROCEDURE (WITH CONSULT-II) 36</p> <p style="padding-left: 20px;">SELF-DIAGNOSTIC PROCEDURE (WITHOUT CONSULT-II) 36</p> <p style="padding-left: 20px;">ERASE SELF-DIAGNOSIS 37</p> <p>TROUBLE DIAGNOSIS FOR SYSTEM 38</p> <p>Power Supply Circuit For Transfer Control Unit 38</p> <p style="padding-left: 20px;">CONSULT-II REFERENCE VALUE IN DATA MONITOR MODE 38</p> <p style="padding-left: 20px;">TRANSFER CONTROL UNIT TERMINALS AND REFERENCE VALUE 38</p> <p style="padding-left: 20px;">DIAGNOSTIC PROCEDURE 39</p> <p style="padding-left: 20px;">COMPONENT INSPECTION 40</p> <p>Transfer Control Unit 40</p> <p style="padding-left: 20px;">DIAGNOSTIC PROCEDURE 40</p> <p>Output Shaft Revolution Signal (TCM) 41</p> <p style="padding-left: 20px;">DIAGNOSTIC PROCEDURE 41</p> <p>Vehicle Speed Sensor (ABS) 42</p>
--	--

DIAGNOSTIC PROCEDURE	42	4WD Warning Lamp Does Not Turn ON	71
4LO Switch	42	SYMPTOM:	71
CONSULT-II REFERENCE VALUE IN DATA		DIAGNOSTIC PROCEDURE	71
MONITOR MODE	42	4WD Shift Indicator Lamp or 4LO Indicator Lamp	
TRANSFER CONTROL UNIT TERMINALS AND		Do Not Change	73
REFERENCE VALUE	42	SYMPTOM:	73
DIAGNOSTIC PROCEDURE	43	DIAGNOSTIC PROCEDURE	73
COMPONENT INSPECTION	44	ATP Warning Lamp Does Not Turn ON	74
4WD Shift Switch	45	SYMPTOM:	74
CONSULT-II REFERENCE VALUE IN DATA		DIAGNOSTIC PROCEDURE	74
MONITOR MODE	45	4WD Shift Indicator Lamp Repeats Flashing	76
TRANSFER CONTROL UNIT TERMINALS AND		SYMPTOM:	76
REFERENCE VALUE	45	DIAGNOSTIC PROCEDURE	77
DIAGNOSTIC PROCEDURE	46	4WD Warning Lamp Flashes Slowly	77
COMPONENT INSPECTION	48	SYMPTOM:	77
Wait Detection Switch	49	DIAGNOSTIC PROCEDURE	78
CONSULT-II REFERENCE VALUE IN DATA		TRANSFER CONTROL UNIT	79
MONITOR MODE	49	Removal and Installation	79
TRANSFER CONTROL UNIT TERMINALS AND		REMOVAL	79
REFERENCE VALUE	49	INSTALLATION	79
DIAGNOSTIC PROCEDURE	50	FRONT OIL SEAL	80
COMPONENT INSPECTION	51	Removal and Installation	80
PNP Switch Signal (TCM)	52	REMOVAL	80
DIAGNOSTIC PROCEDURE	52	INSTALLATION	81
Actuator Motor	53	REAR OIL SEAL	82
CONSULT-II REFERENCE VALUE IN DATA		Removal and Installation	82
MONITOR MODE	53	REMOVAL	82
TRANSFER CONTROL UNIT TERMINALS AND		INSTALLATION	82
REFERENCE VALUE	53	TRANSFER CONTROL DEVICE	84
DIAGNOSTIC PROCEDURE	54	Removal and Installation	84
COMPONENT INSPECTION	56	REMOVAL	84
Actuator Position Switch	57	INSTALLATION	84
CONSULT-II REFERENCE VALUE IN DATA		AIR BREATHER HOSE	86
MONITOR MODE	57	Removal and Installation	86
TRANSFER CONTROL UNIT TERMINALS AND		TRANSFER ASSEMBLY	87
REFERENCE VALUE	57	Removal and Installation	87
DIAGNOSTIC PROCEDURE	58	REMOVAL	87
Transfer Control Device	60	INSTALLATION	87
CONSULT-II REFERENCE VALUE IN DATA		Disassembly and Assembly	88
MONITOR MODE	60	COMPONENTS	88
TRANSFER CONTROL UNIT TERMINALS AND		DISASSEMBLY	90
REFERENCE VALUE	60	INSPECTION AFTER DISASSEMBLY	95
DIAGNOSTIC PROCEDURE	61	ASSEMBLY	96
Engine Speed Signal (ECM)	63	PLANETARY CARRIER	104
DIAGNOSTIC PROCEDURE	63	Disassembly and Assembly	104
CAN Communication Line	64	DISASSEMBLY	104
DIAGNOSTIC PROCEDURE	64	INSPECTION AFTER DISASSEMBLY	105
ATP Switch	64	ASSEMBLY	106
CONSULT-II REFERENCE VALUE IN DATA		FRONT DRIVE SHAFT	108
MONITOR MODE	64	Disassembly and Assembly	108
TRANSFER CONTROL UNIT TERMINALS AND		DISASSEMBLY	108
REFERENCE VALUE	64	INSPECTION AFTER DISASSEMBLY	108
DIAGNOSTIC PROCEDURE	65	ASSEMBLY	109
COMPONENT INSPECTION	66	SHIFT CONTROL	110
TROUBLE DIAGNOSIS FOR SYMPTOMS	68	Disassembly and Assembly	110
4WD Shift Indicator Lamp and 4LO Indicator Lamp		DISASSEMBLY	110
Do Not Turn ON	68	INSPECTION AFTER DISASSEMBLY	110
SYMPTOM:	68	ASSEMBLY	111
DIAGNOSTIC PROCEDURE	68	SERVICE DATA AND SPECIFICATIONS (SDS) ...	112

General Specifications	112	Pinion Gear End Play	112
		Clearance Between Shift Fork and Sleeve	112

A

B

C

TF

E

F

G

H

I

J

K

L

M

PRECAUTIONS

PRECAUTIONS

PFP:00001

Precautions for Supplemental Restraint System (SRS) “AIR BAG” and “SEAT BELT PRE-TENSIONER”

EDS001MG

The Supplemental Restraint System such as “AIR BAG” and “SEAT BELT PRE-TENSIONER”, used along with a front seat belt, helps to reduce the risk or severity of injury to the driver and front passenger for certain types of collision. This system includes seat belt switch inputs and dual stage front air bag modules. The SRS system uses the seat belt switches to determine the front air bag deployment, and may only deploy one front air bag, depending on the severity of a collision and whether the front occupants are belted or unbelted. Information necessary to service the system safely is included in the SRS and SB section of this Service Manual.

WARNING:

- To avoid rendering the SRS inoperative, which could increase the risk of personal injury or death in the event of a collision which would result in air bag inflation, all maintenance must be performed by an authorized NISSAN/INFINITI dealer.
- Improper maintenance, including incorrect removal and installation of the SRS, can lead to personal injury caused by unintentional activation of the system. For removal of Spiral Cable and Air Bag Module, see the SRS section.
- Do not use electrical test equipment on any circuit related to the SRS unless instructed to in this Service Manual. SRS wiring harnesses can be identified by yellow and/or orange harnesses or harness connectors.





Precautions for Transfer Assembly and Transfer Control Unit Replacement

EDS001MH

When replacing transfer assembly or transfer control unit, check the 4WD shift indicator pattern and adjustment of the position between transfer assembly and transfer control unit if necessary.

CHECK 4WD SHIFT INDICATOR PATTERN

1. Set 4WD shift switch to “2WD”, “4H”, “4LO”, “4H” and “2WD” in order. (Stay at each switch position for at least 2 seconds.)
2. Confirm 4WD shift indicator lamp and 4LO indicator lamp are changed properly as follows.

4WD shift switch	Indicator lamp		Operation of 4WD shift switch
	4WD shift	4LO	
2WD		OFF	2WD ⇌ 4H switching can be done while driving. The indicator lamp will change when the driving mode is changed. Gear shifting between 2WD ⇌ 4H position must be performed at speeds below 100km/h (60 MPH).
4H			
4LO		Flashing	To shift between 4H ⇌ 4LO, stop the vehicle and select the A/T selector lever to the “N” position with the brake pedal depressed. Depress and turn the 4WD shift switch. The 4WD shift switch will not shift to the desired mode if the transmission is not in “N” or the vehicle is moving with the brake pedal depressed. The 4LO indicator lamp will be lit when the 4LO is engaged.
		ON	

SDIA2481E

- If OK, the position between transfer assembly and transfer control unit is correct.
- If NG, the position is different between transfer assembly and transfer control unit. Adjust the position between transfer assembly and transfer control unit. Refer to pattern table below.

PRECAUTIONS

Transfer position adjustment pattern

4WD shift switch condition	Refer procedure
4WD shift switch is under "2WD" condition when engine is being stopped.	TF-5, "METHOD FOR ADJUSTMENT WITH 4WD SHIFT SWITCH AT "2WD" "
4WD shift switch is under "4H" or "4LO" condition when engine is being stopped.	TF-5, "METHOD FOR ADJUSTMENT WITH 4WD SHIFT SWITCH AT "4H" OR "4LO" "

NOTE:

Method of adjustment can be chosen voluntarily, according to location of 4WD shift switch.

METHOD FOR ADJUSTMENT WITH 4WD SHIFT SWITCH AT "2WD"

Select adjustment pattern

1. Start engine. (Stay for at least 10 seconds.)
2. Check 4WD shift indicator lamp and 4LO indicator lamp.

Indicator lamp condition	Refer procedure
When 4WD shift indicator lamp or 4LO indicator lamp is flashing.	TF-5, "Pattern A"
Except for above.	TF-5, "Pattern B"

Pattern A

1. Stop vehicle and move A/T selector lever to "N" position with brake pedal depressed. (Stay for at least 2 seconds.)
2. Turn 4WD shift switch to "4LO" position. (Stay for at least 2 seconds.)
3. Turn ignition switch "OFF".
4. Start engine.
5. Erase self-diagnosis. Refer to [TF-34, "How to erase self-diagnostic results"](#) (with CONSULT-II) or [TF-37, "ERASE SELF-DIAGNOSIS"](#) (without CONSULT-II).
6. Check 4WD shift indicator lamp and 4LO indicator lamp again. Refer to [TF-4, "CHECK 4WD SHIFT INDICATOR PATTERN"](#) .
If 4WD shift indicator lamp and 4LO indicator lamp do not indicate proper pattern, install new transfer control unit and retry the above check.

Pattern B

1. Stop vehicle and move A/T selector lever to "N" position with brake pedal depressed. (Stay for at least 2 seconds.)
2. Turn ignition switch "OFF".
3. Start engine.
4. Erase self-diagnosis. Refer to [TF-34, "How to erase self-diagnostic results"](#) (with CONSULT-II) or [TF-37, "ERASE SELF-DIAGNOSIS"](#) (without CONSULT-II).
5. Check 4WD shift indicator lamp and 4LO indicator lamp again. Refer to [TF-4, "CHECK 4WD SHIFT INDICATOR PATTERN"](#) .
If 4WD shift indicator lamp and 4LO indicator lamp do not indicate proper pattern, install new transfer control unit and retry the above check.

METHOD FOR ADJUSTMENT WITH 4WD SHIFT SWITCH AT "4H" OR "4LO"

1. Start engine. (Stay for at least 10 second.)
2. Stop vehicle and move A/T selector lever to "N" position with brake pedal depressed. (Stay for at least 2 seconds.)
3. Turn 4WD shift switch to "2WD" position. (Stay for at least 2 seconds.)
4. Turn ignition switch "OFF".
5. Start engine.
6. Erase self-diagnosis. Refer to [TF-34, "How to erase self-diagnostic results"](#) (with CONSULT-II) or [TF-37, "ERASE SELF-DIAGNOSIS"](#) (without CONSULT-II).
7. Check 4WD shift indicator lamp and 4LO indicator lamp again. Refer to [TF-4, "CHECK 4WD SHIFT INDICATOR PATTERN"](#) .
If 4WD shift indicator lamp and 4LO indicator lamp do not indicate proper pattern, install new transfer control unit and retry the above check.

PRECAUTIONS

EDS001MI

Precautions

- Before connecting or disconnecting the transfer control unit harness connector, turn ignition switch "OFF" and disconnect battery ground cable. Because battery voltage is applied to transfer control unit even if ignition switch is turned "OFF".

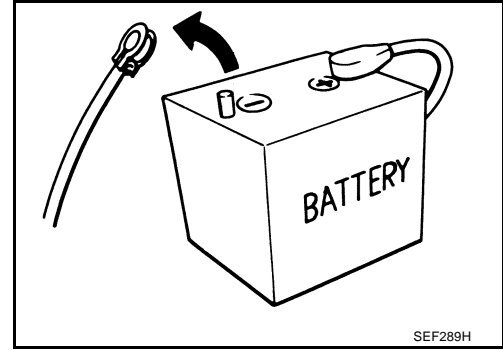

- When connecting or disconnecting pin connectors into or from transfer control unit, take care not to damage pin terminals (bend or break). When connecting pin connectors make sure that there are not any bends or breaks on transfer control unit pin terminal.

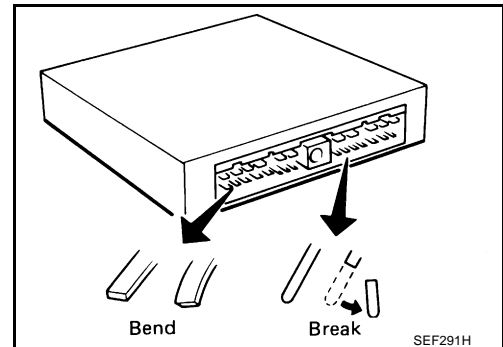

- Before replacing transfer control unit, perform transfer control unit input/output signal inspection and make sure transfer control unit functions properly. Refer to [TF-27, "Transfer Control Unit Input/Output Signal Reference Values"](#).

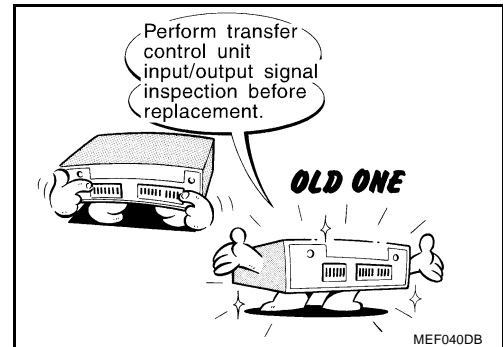

Service Notice

EDS001MJ

- After overhaul refill the transfer with new transfer fluid.
- Check the fluid level or replace the fluid only with the vehicle parked on level ground.
- During removal or installation, keep inside of transfer clear of dust or dirt.
- Disassembly should be done in a clean work area.
- Before proceeding with disassembly, thoroughly clean the transfer. It is important to prevent the internal parts from becoming contaminated by dirt or other foreign matter.
- Check for the correct installation status prior to removal or disassembly. If matchmarks are required, be certain they do not interfere with the function of the parts when applied.
- All parts should be carefully cleaned with a general purpose, non-flammable solvent before inspection or reassembly.
- Check appearance of the disassembled parts for damage, deformation, and unusual wear. Replace them with a new ones if necessary.
- Gaskets, seals and O-rings should replaced any time the transfer is disassembled.
- In principle, tighten bolts or nuts gradually in several steps working diagonally from inside to outside. If tightening sequence is specified, use it.
- Observe the specified torque when assembling.
- Clean and flush the parts sufficiently and blow-dry them.
- Be careful not to damage sliding surfaces and mating surfaces.

PRECAUTIONS

- Use lint-free cloth or towels for wiping parts clean. Common shop rags can leave fibers that could interfere with the operation of the transfer.

A

Wiring Diagrams and Trouble Diagnosis

EDS001MK

When reading wiring diagrams, refer to the following:

- [GI-15, "How to Read Wiring Diagrams"](#).
- [PG-4, "POWER SUPPLY ROUTING CIRCUIT"](#).

B

When performing trouble diagnosis, refer to the following:

- [GI-11, "How to Follow Trouble Diagnoses"](#).
- [GI-27, "How to Perform Efficient Diagnosis for an Electrical Incident"](#).

C

TF

E

F

G

H

I

J

K

L

M

PREPARATION

PFP:00002

EDS001ML

PREPARATION

Special Service Tools

The actual shapes of Kent-Moore tools may differ from those of special service tools illustrated here.

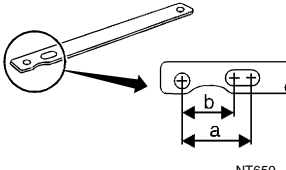
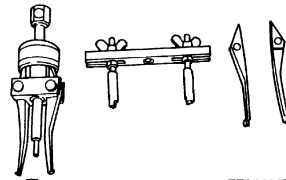
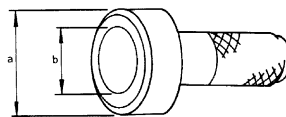
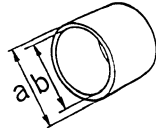
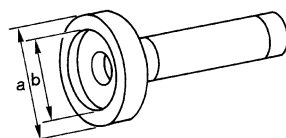
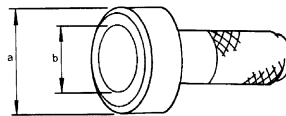
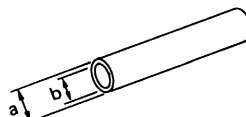
Tool number (Kent-Moore No.) Tool name		Description
KV40104000 (—) Flange wrench		<ul style="list-style-type: none"> ● Removing self-lock nut ● Installing self-lock nut <p>a: 85 mm (3.35 in) b: 65 mm (2.56 in)</p>
ST33290001 (J-34286) Puller		<ul style="list-style-type: none"> ● Removing front oil seal ● Removing rear oil seal ● Removing metal bushing
KV38100500 (—) Drift		<ul style="list-style-type: none"> ● Installing front oil seal ● Installing rear oil seal ● Installing rear bearing ● Installing front bearing <p>a: 80 mm (3.15 in) dia. b: 60 mm (2.36 in) dia.</p>
KV40105310 (—) Drift		<ul style="list-style-type: none"> ● Installing dust cover <p>a: 89 mm (3.50 in) dia. b: 80.7 mm (3.17 in) dia.</p>
KV38100200 (—) Drift		<ul style="list-style-type: none"> ● Removing sun gear assembly ● Removing input bearing ● Installing sun gear assembly <p>a: 65 mm (2.56 in) dia. b: 49 mm (1.93 in) dia.</p>
ST30720000 (J-25405) Drift		<ul style="list-style-type: none"> ● Installing input bearing ● Installing input oil seal ● Installing carrier bearing <p>a: 77 mm (3.03 in) dia. b: 55 mm (2.17 in) dia.</p>
KV32102700 (—) Drift		<ul style="list-style-type: none"> ● Installing mainshaft rear bearing <p>a: 48 mm (1.89 in) dia. b: 41 mm (1.61 in) dia.</p>

PREPARATION

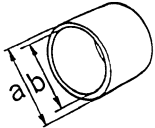
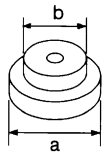
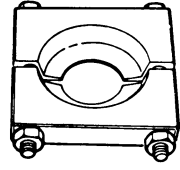
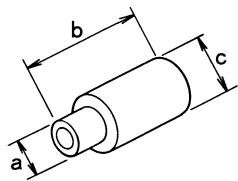
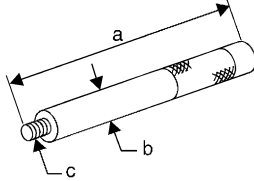
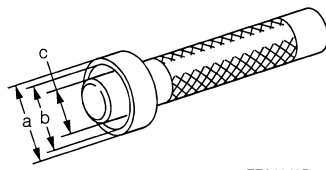
Tool number (Kent-Moore No.) Tool name	Description	
KV40104830 (—) Drift  ZZA1003D	<ul style="list-style-type: none"> ● Installing input oil seal <p>a: 70 mm (2.76 in) dia. b: 63.5 mm (2.50 in) dia.</p>	A B C
ST35300000 (—) Drift  NT073	<ul style="list-style-type: none"> ● Removing carrier bearing ● Installing metal bushing ● Removing front bearing <p>a: 59 mm (2.32 in) dia. b: 45 mm (1.77 in) dia.</p>	TF E
ST30021000 (J-22912-01) Puller  ZZA0537D	<ul style="list-style-type: none"> ● Removing carrier bearing ● Removing front bearing ● Removing rear bearing 	F G H
ST33710000 (—) Drift  ZZA1057D	<ul style="list-style-type: none"> ● Removing needle bearing ● Removing metal bushing ● Removing rear bearing <p>a: 89 mm (3.5 in) b: 30 mm (1.18 in) dia. c: 24 mm (0.94 in) dia.</p>	I J
ST35325000 (—) Drift bar  NT663	<ul style="list-style-type: none"> ● Removing metal bushing <p>a: 215 mm (8.46 in) b: 25 mm (0.98 in) dia. c: M12 × 1.5P</p>	K L
ST33220000 (—) Drift  ZZA1046D	<ul style="list-style-type: none"> ● Installing needle bearing <p>a: 37 mm (1.46 in) dia. b: 31 mm (1.22 in) dia. c: 22 mm (0.87 in) dia.</p>	M

PREPARATION

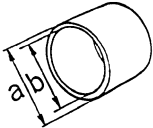
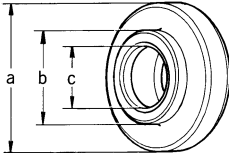
Tool number (Kent-Moore No.) Tool name	Description
ST27863000 (—) Drift <div style="text-align: center;">  <p>ZZA1003D</p> </div>	<ul style="list-style-type: none"> ● Installing carrier bearing <p>a: 75 mm (2.95 in) dia. b: 62 mm (2.44 in) dia.</p>
ST30901000 (J-26010-01) Drift <div style="text-align: center;">  <p>ZZA0978D</p> </div>	<ul style="list-style-type: none"> ● Installing rear bearing ● Installing front bearing <p>a: 79 mm (3.11 in) dia. b: 45 mm (1.77 in) dia. c: 35.2 mm (1.38 in) dia.</p>

Commercial Service Tools

EDS001MM

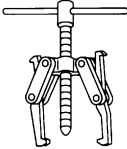
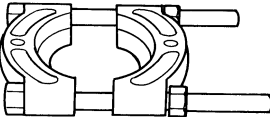
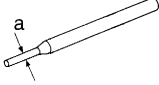
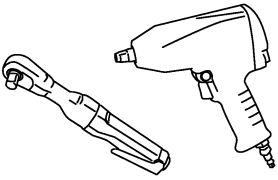
Tool name	Description
Puller <div style="text-align: center;">  <p>NT077</p> </div>	<ul style="list-style-type: none"> ● Removing companion flange ● Removing mainshaft rear bearing
Puller <div style="text-align: center;">  <p>ZZB0823D</p> </div>	<ul style="list-style-type: none"> ● Removing mainshaft rear bearing
Pin punch <div style="text-align: center;">  <p>NT410</p> </div>	<ul style="list-style-type: none"> ● Removing retaining pin <p>a: 6mm (0.24in) dia.</p>
Power tool <div style="text-align: center;">  <p>PBIC0190E</p> </div>	<ul style="list-style-type: none"> ● Loosening bolts and nuts

NOISE, VIBRATION AND HARSHNESS (NVH) TROUBLESHOOTING

NOISE, VIBRATION AND HARSHNESS (NVH) TROUBLESHOOTING

PDF:00003

NVH Troubleshooting Chart

EDS001MN

Use the chart below to help you find the cause of the symptom. The numbers indicate the order of the inspection. If necessary, repair or replace these parts.

Reference page		IF-12			IF-88			IF-110	IF-96	IF-105
SUSPECTED PARTS (Possible cause)		TRANSFER FLUID (Level low)	TRANSFER FLUID (Wrong)	TRANSFER FLUID (Level too high)	LIQUID GASKET (Damaged)	O-RING (Worn or damaged)	OIL SEAL (Worn or damaged)	SHIFT FORK (Worn or damaged)	GEAR (Worn or damaged)	BEARING (Worn or damaged)
Symptom	Noise	1	2						3	3
	Transfer fluid leakage		3	1	2	2	2			
	Hard to shift or will not shift		1	1				2		

A
B
C
TF
E
F
G
H
I
J
K
L
M

TRANSFER FLUID

PF3:31001

EDS001MO

TRANSFER FLUID

Replacement DRAINING

1. Stop engine.
2. Remove the drain plug and gasket. Drain the fluid.
3. Install the drain plug with a new gasket to the transfer. Tighten to the specified torque. Refer to [TF-88, "COMPONENTS"](#) .

CAUTION:

Do not reuse gasket.

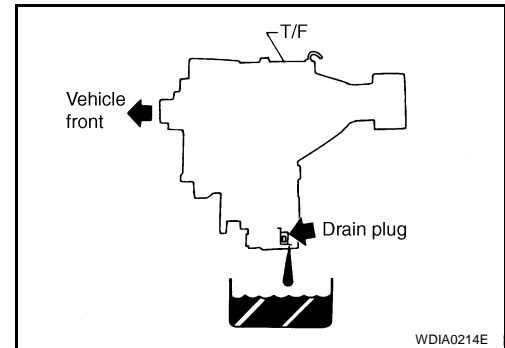

FILLING

1. Remove the filler plug and gasket.
2. Fill the transfer with new fluid until the fluid level reaches the specified limit near the filler plug hole.

Fluid grade:

Refer to [MA-11, "Fluids and Lubricants"](#) .

Fluid capacity:

Approx. 2.0 ℓ (2-1/8 US pt, 1-3/4 Imp pt)

CAUTION:

Carefully fill fluid. (Fill up for approx. 3 minutes.)

3. Leave the vehicle for 3 minutes, and check fluid level again.
4. Install the filler plug with a new gasket to the transfer. Tighten to the specified torque. Refer to [TF-88, "COMPONENTS"](#) .

CAUTION:

Do not reuse gasket.

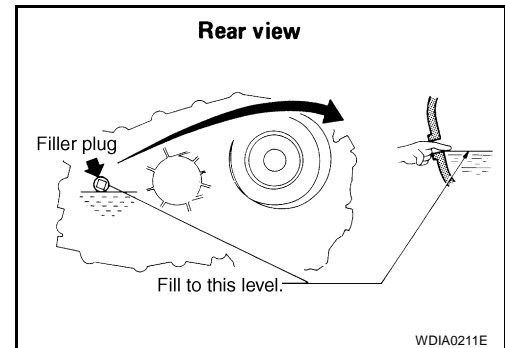

Inspection

FLUID LEAKAGE AND FLUID LEVEL

EDS001MP

1. Make sure that fluid is not leaking from the transfer assembly or around it.
2. Check fluid level from the filler plug hole as shown.

CAUTION:

Do not start engine while checking fluid level.

3. Install the filler plug with a new gasket to the transfer. Tighten to the specified torque. Refer to [TF-88, "COMPONENTS"](#) .

CAUTION:

Do not reuse gasket.

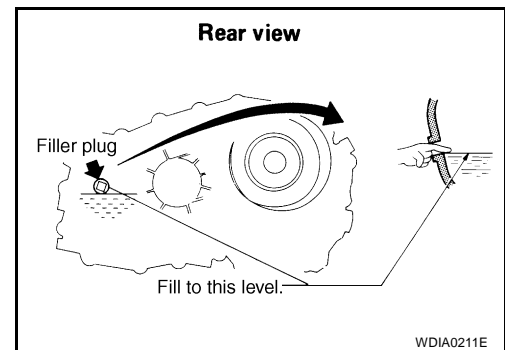

4WD SYSTEM

PFP:33084

4WD SYSTEM

Cross-section View

EDS001MQ

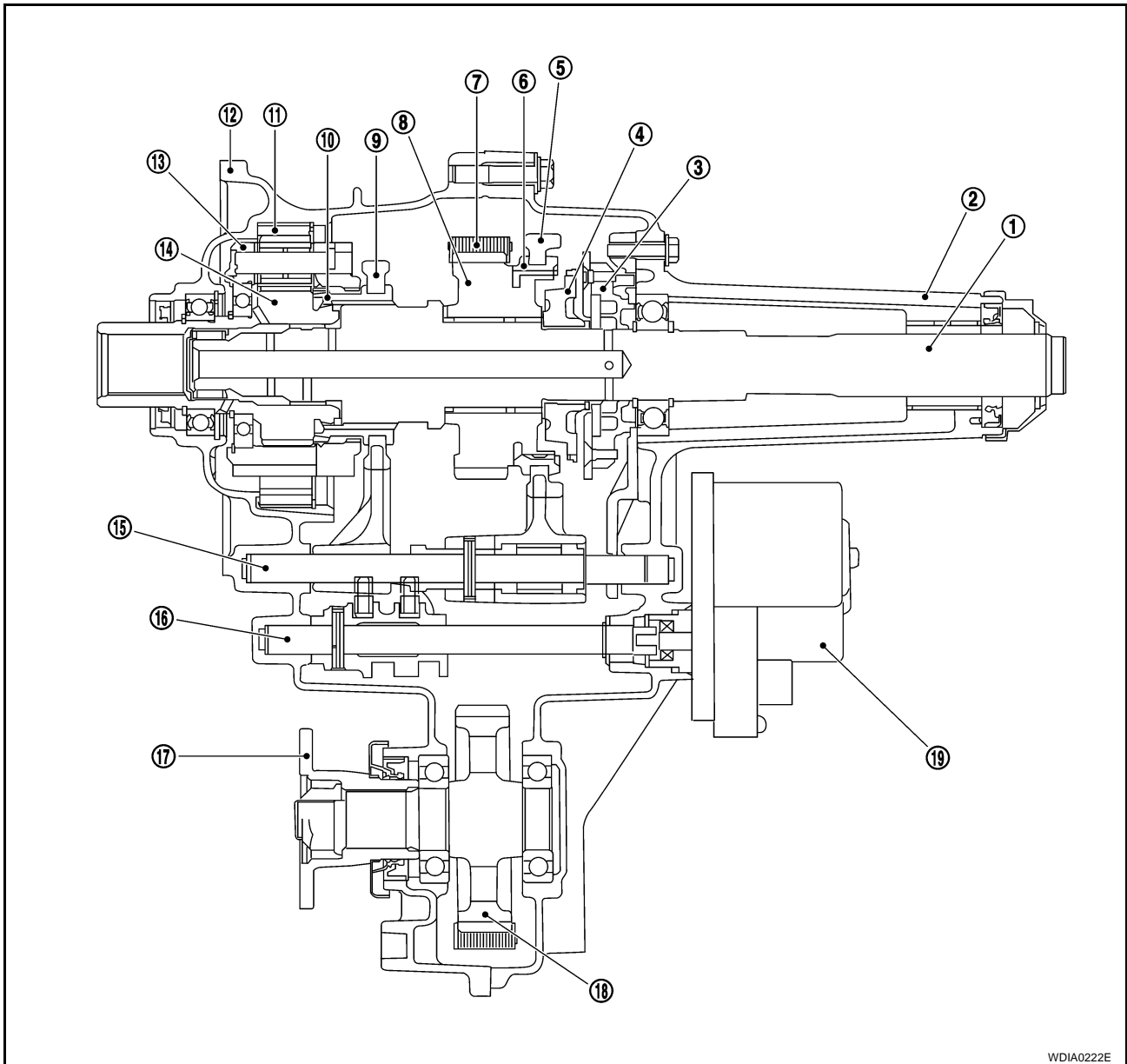

- | | | |
|--------------------------------|-----------------------|-----------------------|
| 1. Mainshaft | 2. Rear case | 3. Oil pump assembly |
| 4. Clutch gear | 5. 2-4 shift fork | 6. 2-4 sleeve |
| 7. Drive chain | 8. Sprocket | 9. L-H shift fork |
| 10. L-H sleeve | 11. Internal gear | 12. Front case |
| 13. Planetary carrier assembly | 14. Sun gear assembly | 15. L-H shift rod |
| 16. Control shift rod | 17. Companion flange | 18. Front drive shaft |
| 19. Transfer control device | | |

WDIA0222E

4WD SYSTEM

EDS001MR

Power Transfer POWER TRANSFER DIAGRAM

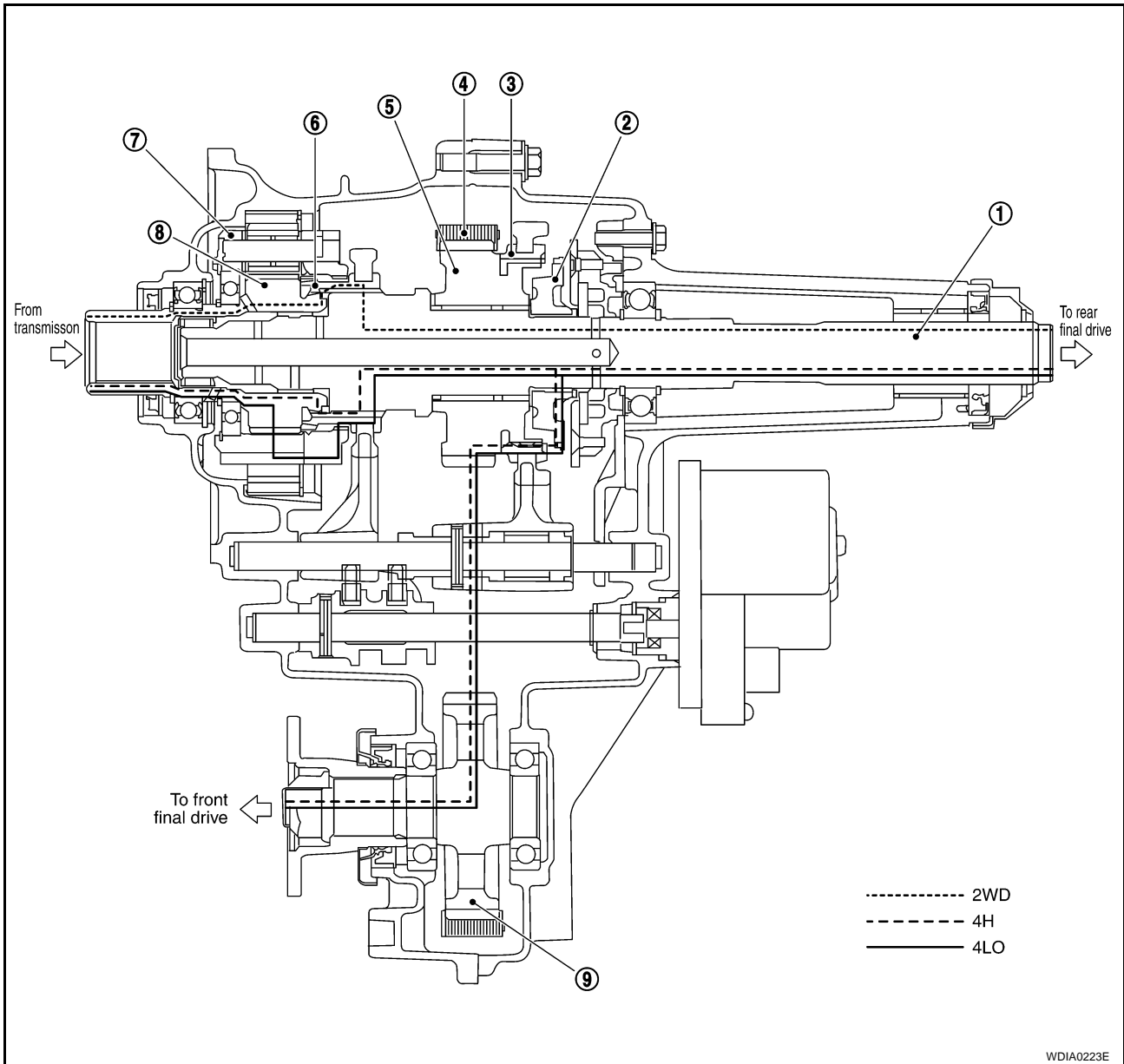

WDIA0223E

- | | | |
|-------------------------------|----------------------|----------------------|
| 1. Mainshaft | 2. Clutch gear | 3. 2-4 sleeve |
| 4. Drive chain | 5. Sprocket | 6. L-H sleeve |
| 7. Planetary carrier assembly | 8. Sun gear assembly | 9. Front drive shaft |

4WD SYSTEM

POWER TRANSFER FLOW

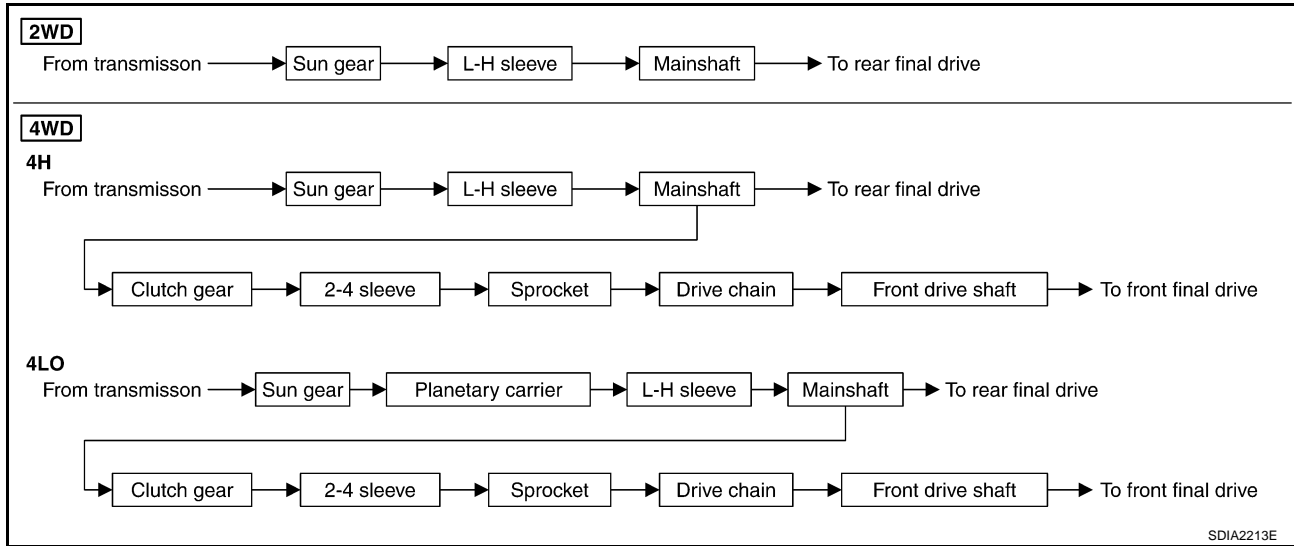

System Description TRANSFER CONTROL DEVICE

EDS001MS

Actuator motor and actuator position switch are integrated. Transfer control device shifts from 4H-4LO and between 2WD-4WD.

Actuator Motor

Actuator motor is operated by signal from transfer control unit and it operates control shift rod so as to shift from 4H-4LO and between 2WD-4WD.

Actuator Position Switch

Actuator position switch detects actuator motor position and sends it to transfer control unit.

WAIT DETECTION SWITCH

Wait detection switch detects if transfer gear is in 4WD by 2-4 shift fork position.

NOTE:

If 4WD shift switch is switched to 4H or 4LO, transfer is not in 4WD completely when gear does not engage. (Wait detection system is operating.)

4LO SWITCH

4LO switch detects if transfer gear is under 4LO condition by L-H shift fork position.

ATP SWITCH

ATP switch detects if transfer gear is under neutral condition by L-H shift fork position.

NOTE:

Transfer gear may be under neutral condition when shifting between 4H-4LO.

TRANSFER CONTROL UNIT





- Transfer control unit controls transfer control device by input signals of each sensor and each switch, and it directs shifts from 4H-4LO and 2WD-4WD.
- Self-diagnosis can be done.

TRANSFER RELAY

Transfer relay applies power to transfer control unit.

4WD SYSTEM

4WD SHIFT SWITCH AND INDICATOR LAMP

4WD shift switch	Indicator lamp		Operation of 4WD shift switch	Use condition
	4WD shift	4LO		
2WD		OFF	2WD ⇌ 4H switching can be done while driving. The indicator lamp will change when the driving mode is changed. Gear shifting between 2WD ⇌ 4H position must be performed at speeds below 100km/h (60 MPH).	For driving on dry, paved roads.
4H				For driving on rough, sandy or snow-covered roads.
4LO		Flashing	To shift between 4H ⇌ 4LO, stop the vehicle and select the A/T selector lever to the "N" position with the brake pedal depressed. Depress and turn the 4WD shift switch. The 4WD shift switch will not shift to the desired mode if the transmission is not in "N" or the vehicle is moving with the brake pedal depressed. The 4LO indicator lamp will be lit when the 4LO is engaged.	The 4LO indicator lamp flashes when shifting between 4LO ⇌ 4H.
		ON	For use when maximum power and traction is required at low speed (for example on steep grades or rocky, sandy, muddy roads.).	

SDIA2363E

4WD Shift Switch

4WD shift switch is able to select from 2WD, 4H or 4LO.

4WD Shift Indicator Lamp

- Displays driving conditions selected by 4WD shift switch with rear indicator, front and center indicator while engine is running. (When 4H or 4LO, 4LO indicator lamp also works on. And when 4WD warning lamp is turned on, all 4WD shift indicator lamps are turned off.)
- Turns ON when ignition switch is turned ON, for purpose of lamp check. Turns OFF approximately 1 second after the engine starts if system is normal.

4LO Indicator Lamp

- Displays 4LO condition while engine is running. 4LO indicator lamp flashes if transfer gear does not shift completely under 4H⇌4LO. In this condition, transfer may be under neutral condition and A/T parking mechanism may not be operated.
- Turns ON when ignition switch is turned ON, for purpose of lamp check. Turns OFF approximately 1 second after the engine starts if system is normal.

4WD SYSTEM

4WD WARNING LAMP

Turns ON or FLASH when there is a malfunction in 4WD system.

Also turns ON when ignition switch is turned ON, for purpose of lamp check. Turns OFF approximately 1 second after the engine starts if system is normal.

4WD Warning Lamp Indication

Condition	4WD warning lamp
Lamp check	Turns ON when ignition switch is turned ON. Turns OFF after engine start.
4WD system malfunction	ON (For indicated malfunction items, see the "NOTE")
During self-diagnosis	Flickers at malfunction mode.
Large difference in diameter of front/rear tires	Slow flashing: 1 time/2 seconds (Continuing to flash until turning ignition switch OFF)
Other than above (system normal)	OFF

NOTE:

4WD warning lamp is turned on when the following one or more parts are malfunctioning.

- Vehicle speed signal (from ABS)
- CAN communication line
- AD converter
- Engine speed signal
- 4WD shift switch
- Wait detection switch
- Actuator motor
- Transfer control device
- PNP switch signal

ATP WARNING LAMP

When A/T selector lever is in "P" position, vehicle may move because A/T parking mechanism does not operate when transfer is under neutral condition. ATP warning lamp is turned on to indicate this condition to the driver.

4WD SYSTEM

System Diagram

EDS001MT

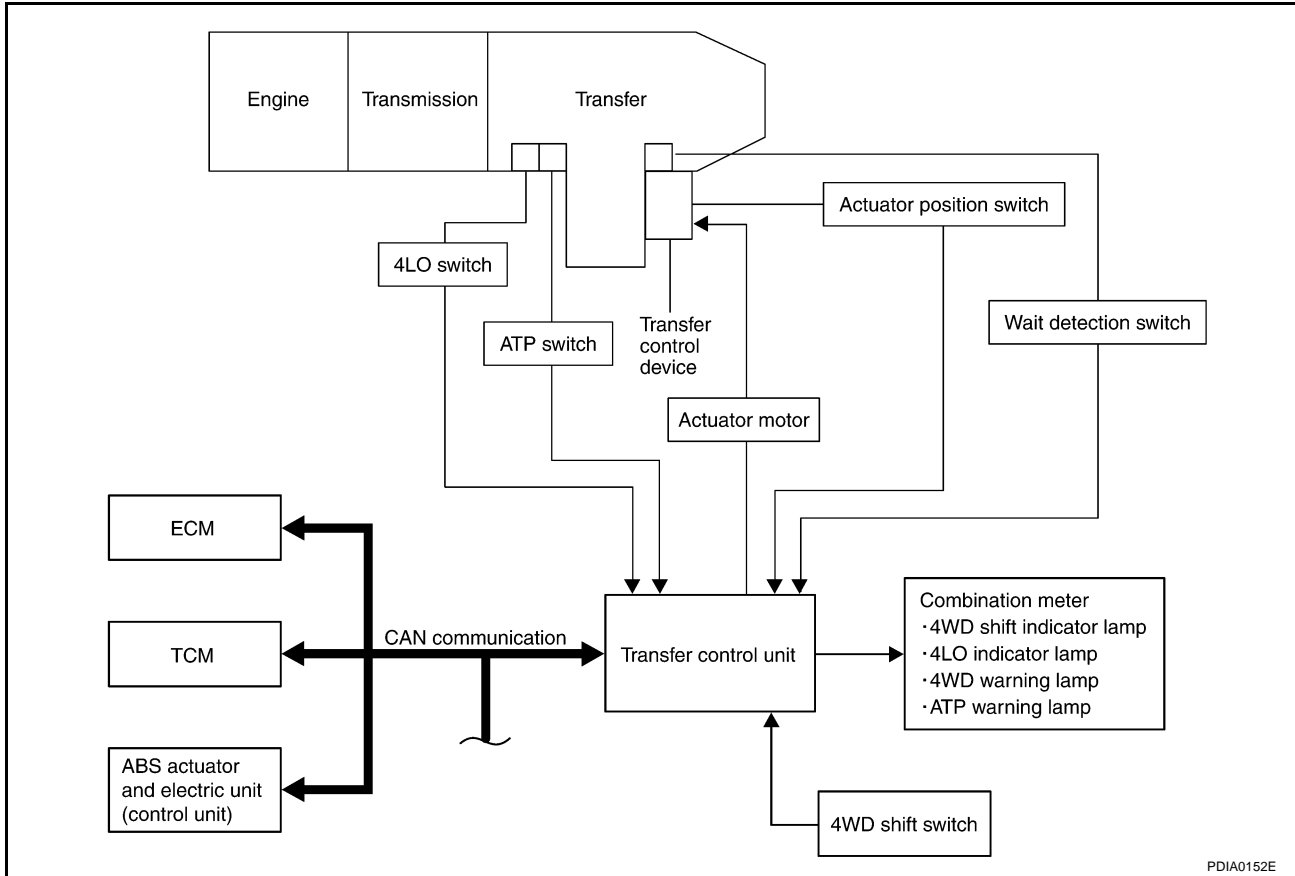

COMPONENTS FUNCTION

Component	Function
Transfer control unit	Controls transfer control device and switches 4H-4LO under 4WD condition and 2WD-4WD.
Transfer control device	Actuator motor and actuator position switch are integrated so as to switch driving types.
Actuator motor	Controls shift rods by signals from transfer control unit.
Actuator position switch	Detects actuator motor position.
Wait detection switch	Detects that transfer is under 4WD condition.
4LO switch	Detects that transfer is under 4LO condition.
ATP switch	Detects that transfer is under neutral condition.
4WD shift switch	Able to select from 2WD, 4H or 4LO.
4WD warning lamp	<ul style="list-style-type: none"> ● Illuminates if malfunction is detected in electrical system of 4WD system. ● There is 1 blink in 2 seconds if rotation difference of front wheels and rear wheels is large.
ATP warning lamp	Indicates that A/T parking mechanism does not operate when A/T selector lever is in "P" position and transfer is under neutral condition.
4WD shift indicator lamp	Displays driving condition selected by 4WD shift switch.
4LO indicator lamp	Displays 4LO condition.
ABS actuator and electric unit (control unit)	Transmits the following signals via CAN communication to Transfer control unit. <ul style="list-style-type: none"> ● Vehicle speed signal ● Stop lamp switch signal (brake signal)
TCM	Transmits the following signal via CAN communication to Transfer control unit. <ul style="list-style-type: none"> ● Output shaft revolution signal ● A/T position indicator signal (PNP switch signal)
ECM	Transmits engine speed signal via CAN communication to Transfer control unit.

CAN Communication

EDS001MU

Refer to [LAN-7, "CAN COMMUNICATION"](#) .

A

B

C

TF

E

F

G

H

I

J

K

L

M

TROUBLE DIAGNOSIS

How to Perform Trouble Diagnosis BASIC CONCEPT

- To perform trouble diagnosis, it is the most important to have understanding about vehicle systems (control and mechanism) thoroughly.
- It is also important to clarify customer complaints before inspection.
First of all, reproduce symptoms, and understand them fully.
Ask customer about his/her complaints carefully. In some cases, it will be necessary to check symptoms by driving vehicle with customer.

CAUTION:

Customers are not professional. It is dangerous to make an easy guess like "maybe the customer means that...," or "maybe the customer mentions this symptom".

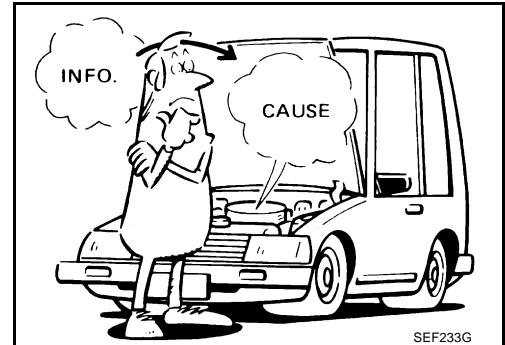

- It is essential to check symptoms right from the beginning in order to repair malfunctions completely.
For intermittent malfunctions, reproduce symptoms based on interview with customer and past examples. Do not perform inspection on ad hoc basis. Most intermittent malfunctions are caused by poor contacts. In this case, it will be effective to shake suspected harness or connector by hand. When repairing without any symptom diagnosis, you cannot judge if malfunctions have actually been eliminated.
- After completing diagnosis, always erase diagnostic memory. Refer to [TF-37, "ERASE SELF-DIAGNOSIS"](#).
- For intermittent malfunctions, move harness or harness connector by hand. Then check for poor contact or reproduced open circuit.

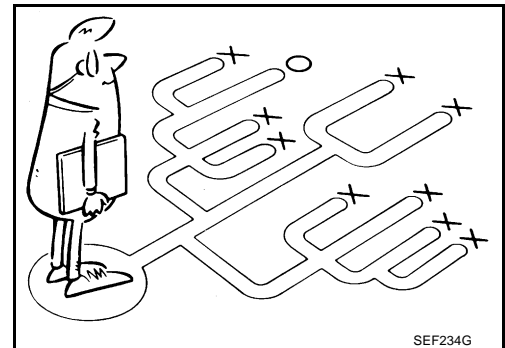

TROUBLE DIAGNOSIS

Location of Electrical Parts

EDS001MW

A
B
C
TF
E
F
G
H
I
J
K
L
M

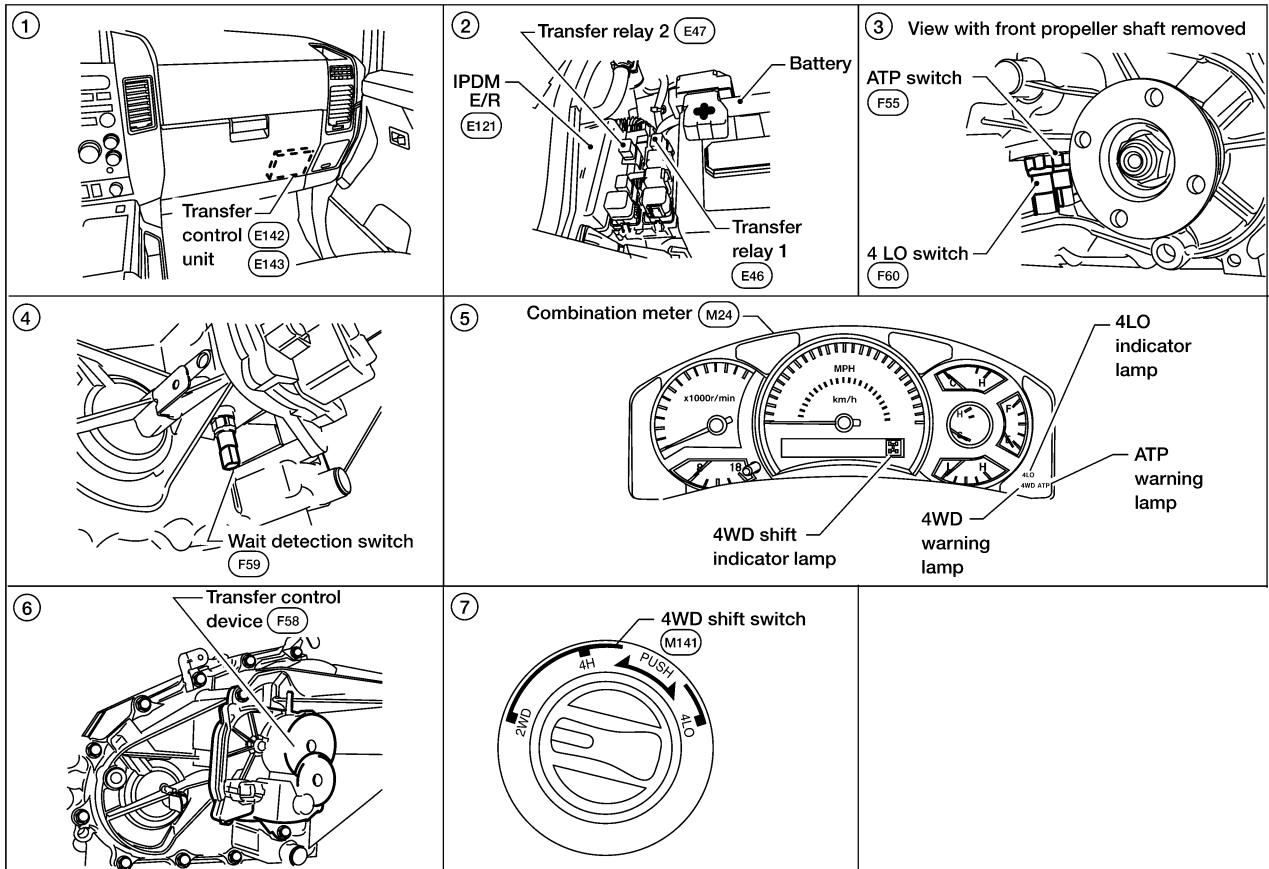
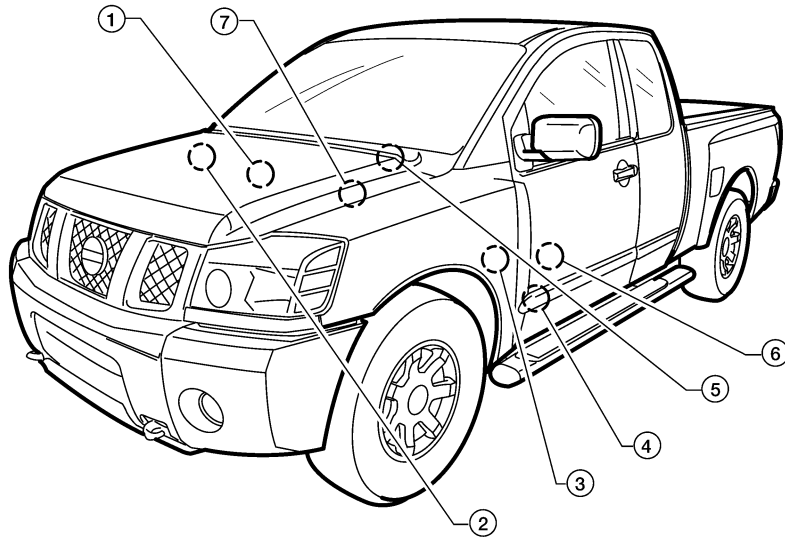

WDIA0208E

TROUBLE DIAGNOSIS

Circuit Diagram

EDS001MX

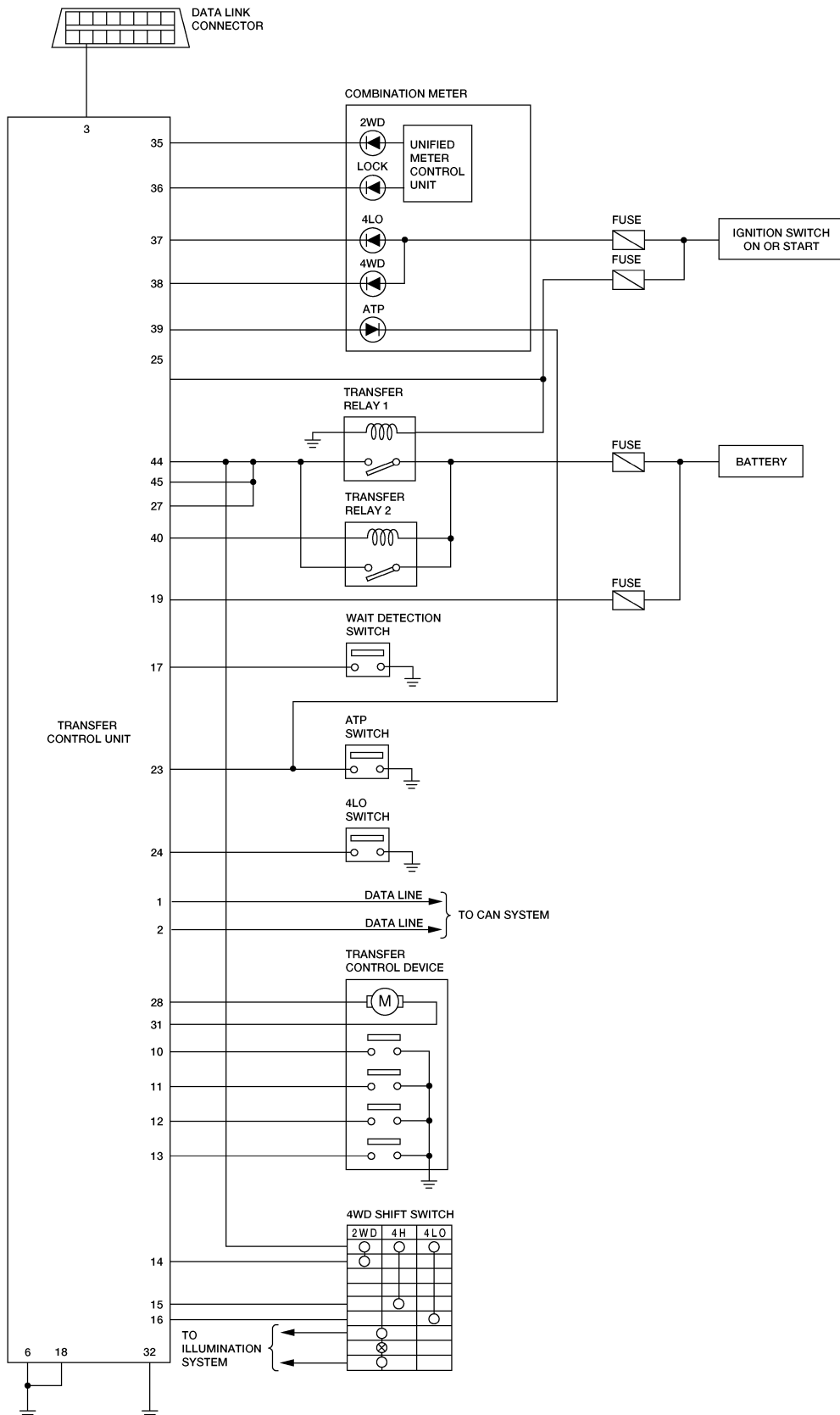

WDWA0040E

TROUBLE DIAGNOSIS

Wiring Diagram — T/F —

EDS001MY

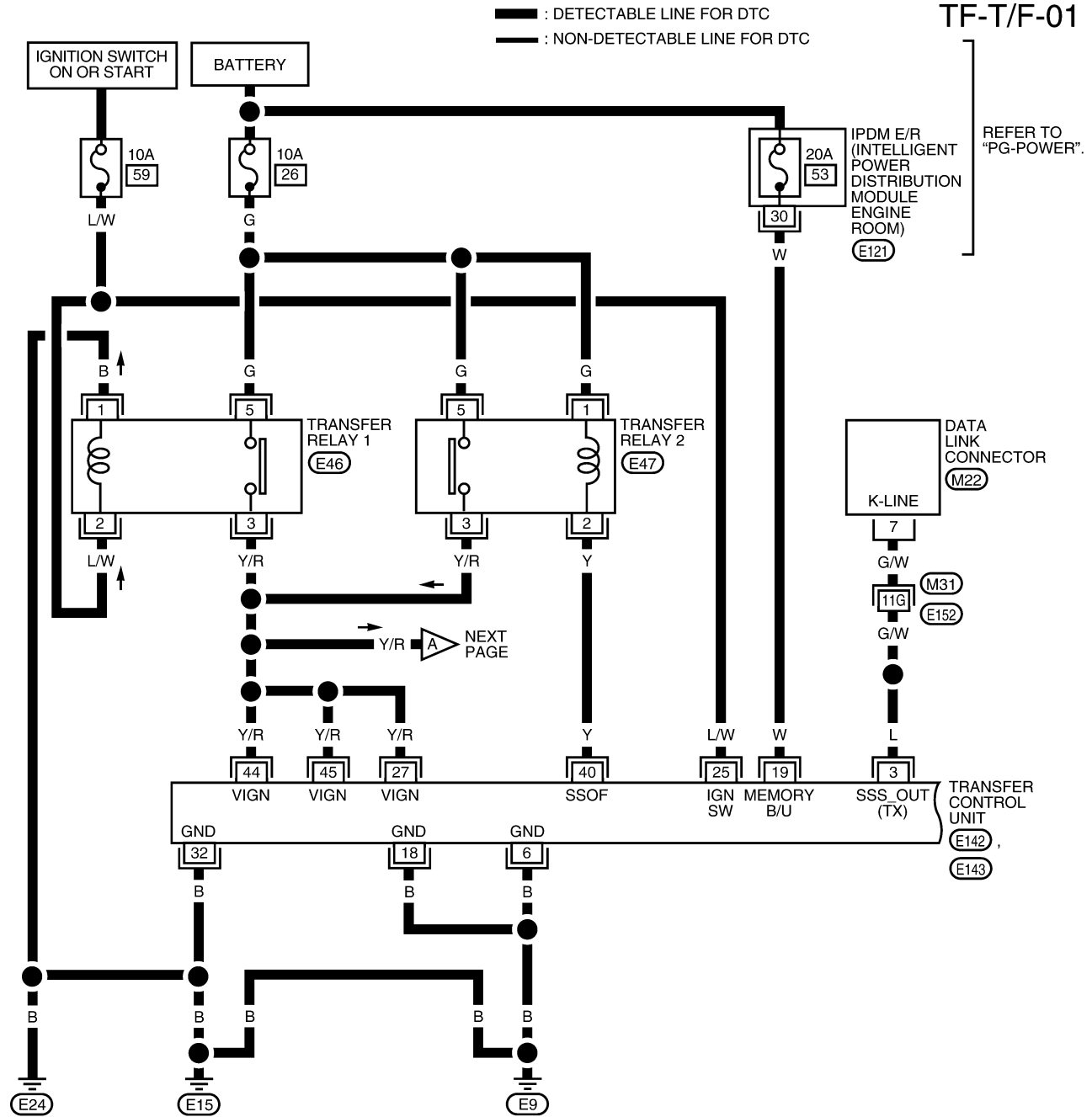

A
B
C
TF
E
F
G
H
I
J
K
L
M

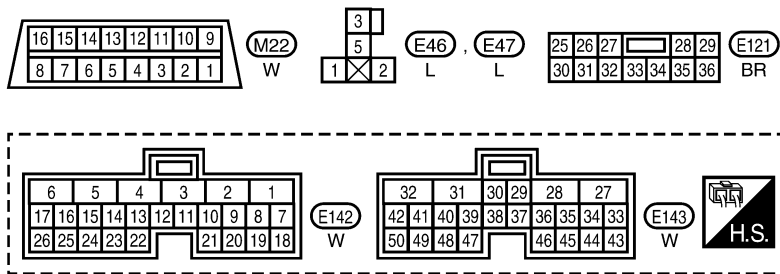

WDWA0025E

TROUBLE DIAGNOSIS

TF-T/F-02

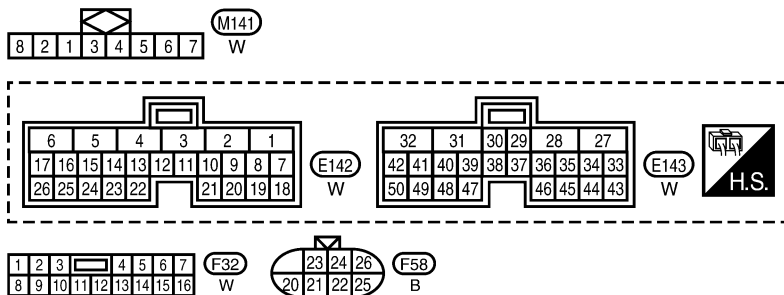
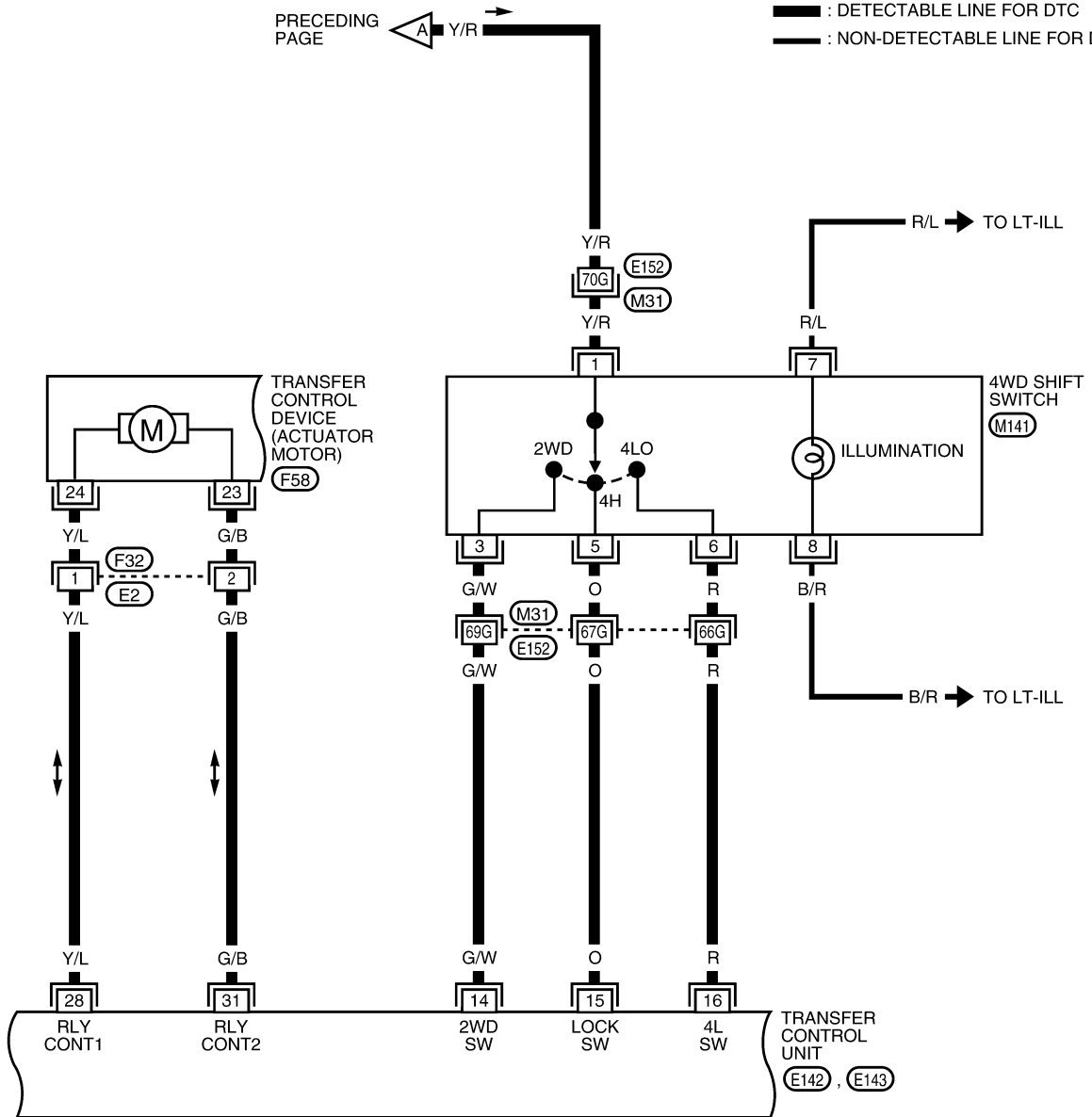

REFER TO THE FOLLOWING.

(M31) - SUPER MULTIPLE JUNCTION (SMJ)

WDWA0026E

TROUBLE DIAGNOSIS

TF-T/F-03

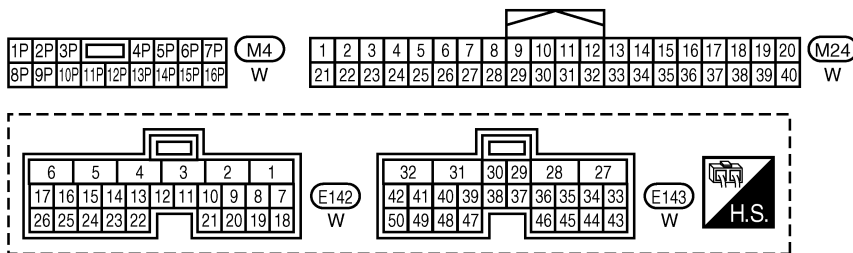
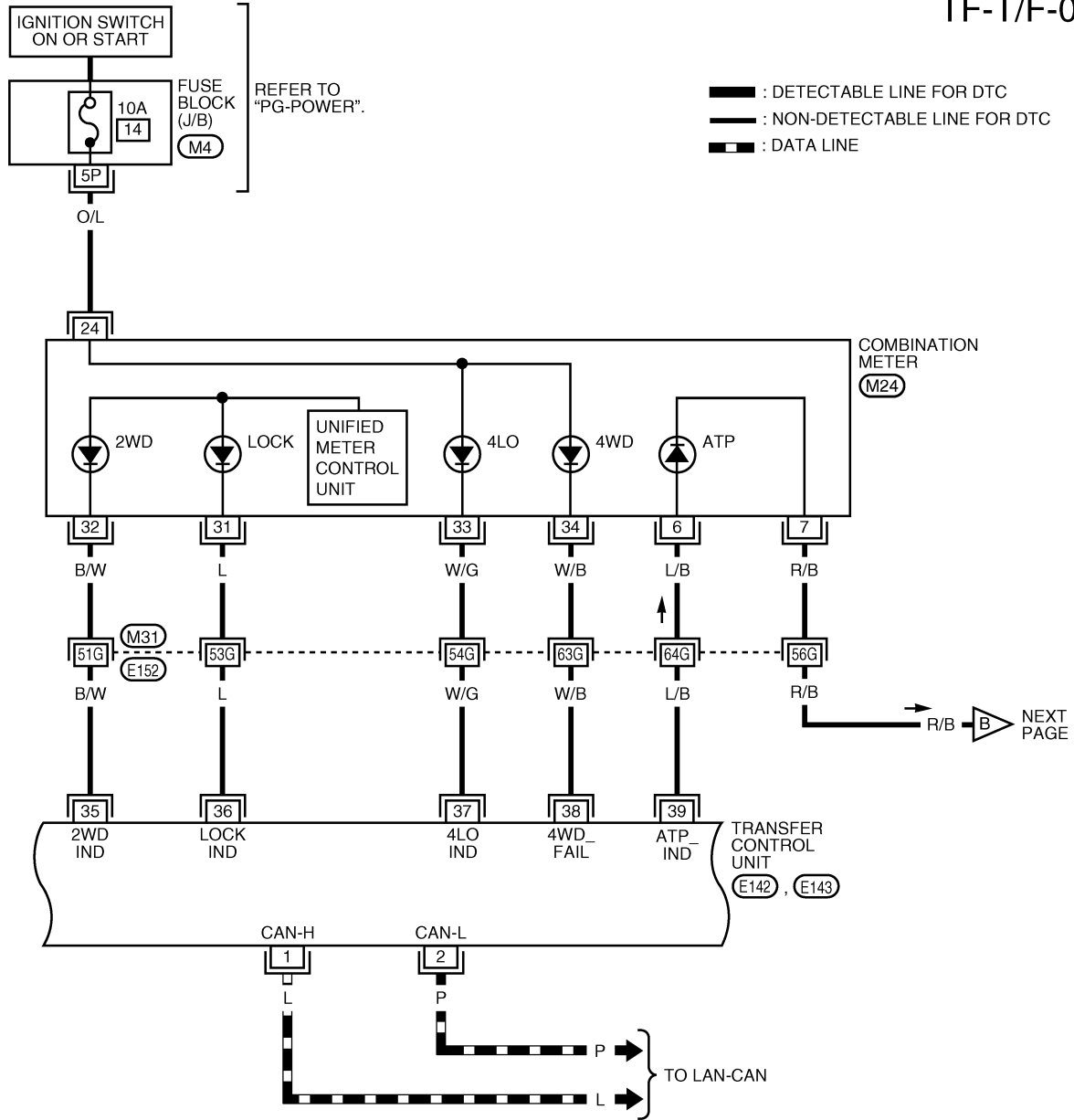

REFER TO THE FOLLOWING.
 M31 - SUPER MULTIPLE JUNCTION (SMJ)

WDWA0041E

TROUBLE DIAGNOSIS

TF-T/F-04

: DETECTABLE LINE FOR DTC
 : NON-DETECTABLE LINE FOR DTC

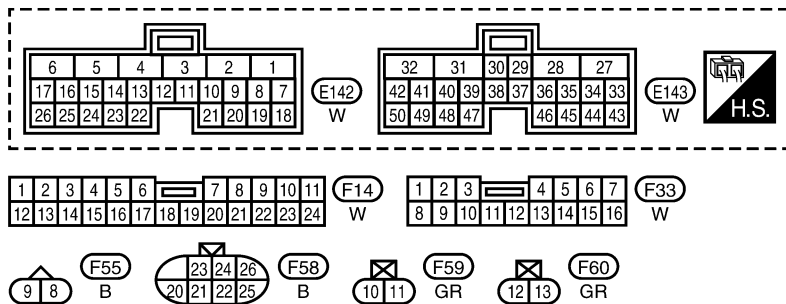
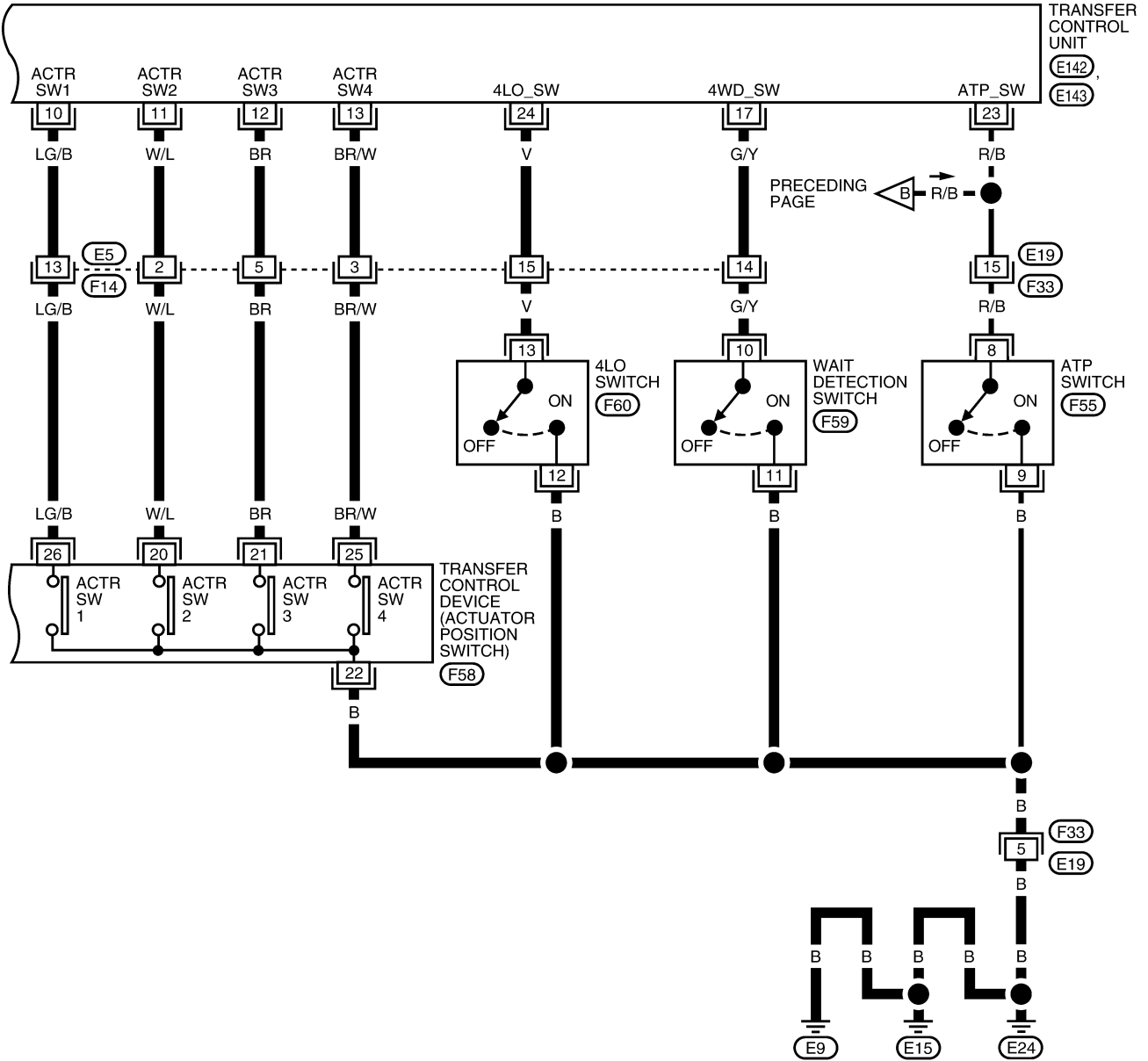

WDWA0028E

TROUBLE DIAGNOSIS

Trouble Diagnosis Chart for Symptoms

EDS001M2

If 4WD warning lamp turns ON, perform self-diagnosis. Refer to [TF-36, "Self-Diagnostic Procedure"](#).

Symptom	Condition	Check item	Reference page
4WD shift indicator lamp and 4LO indicator lamp do not turn ON (4WD shift indicator lamp and 4LO indicator lamp check)	Ignition switch: ON	Power supply and ground for transfer control unit	TF-68
		Combination meter	
4WD warning lamp does not turn ON (4WD warning lamp check)	Ignition switch: ON	Power supply and ground for transfer control unit	TF-71
		Combination meter	
4WD shift indicator lamp or 4LO indicator lamp does not change	Engine running	4WD shift switch	TF-73
		Wait detection switch	
		4LO switch	
		ATP switch	
		Transfer inner parts	
ATP warning lamp does not turn ON	Engine running	CAN communication line	TF-74
		4WD shift switch	
		PNP switch signal	
		ATP switch	
		Combination meter	
		Transfer inner parts	
4WD shift indicator lamp repeats flashing	Engine running	Wait detection switch	TF-76
		4LO switch	
		Transfer inner parts	
4WD warning lamp flashes slowly Slow flashing: 1 time/2 seconds	While driving	Tire size is different between front and rear of vehicle.	TF-77

Transfer Control Unit Input/Output Signal Reference Values

EDS001N0

TRANSFER CONTROL UNIT INSPECTION TABLE

Specifications with CONSULT-II

Monitored item [Unit]	Content	Condition	Display value
VHCL/S SEN-FR [km/h] or [mph]	Wheel speed (Front wheel)	Vehicle stopped	0 km/h (0 mph)
		Vehicle running CAUTION: Check air pressure of tire under standard condition.	Approximately equal to the indication on speedometer (Inside of ±10%)
VHCL/S SEN-RR [km/h] or [mph]	Wheel speed (Rear wheel)	Vehicle stopped	0 km/h (0 mph)
		Vehicle running CAUTION: Check air pressure of tire under standard condition.	Approximately equal to the indication on speedometer (Inside of ±10%)
ENGINE SPEED [rpm]	Engine speed	Engine stopped (Engine speed: Less than 400 rpm)	0 rpm
		Engine running (Engine speed: 400 rpm or more)	Approximately equal to the indication on tachometer
BATTERY VOLT [V]	Power supply voltage for transfer control unit	Ignition switch: ON	Battery voltage
2WD SWITCH [ON/OFF]	Input condition from 4WD shift switch	4WD shift switch: 2WD	ON
		4WD shift switch: 4H and 4LO	OFF

TROUBLE DIAGNOSIS

Monitored item [Unit]	Content	Condition	Display value	
4H SWITCH [ON/OFF]	Input condition from 4WD shift switch	4WD shift switch: 4H	ON	
		4WD shift switch: 2WD and 4LO	OFF	
4L SWITCH [ON/OFF]	Input condition from 4WD shift switch	4WD shift switch: 4LO	ON	
		4WD shift switch: 2WD and 4H	OFF	
4L POSI SW [ON/OFF]	Condition of 4LO switch	<ul style="list-style-type: none"> ● Vehicle stopped ● Engine running ● A/T selector lever "N" position ● Brake pedal depressed 	4WD shift switch: 4LO	ON
		Except the above	OFF	
ATP SWITCH [ON/OFF]	Condition of ATP switch	<ul style="list-style-type: none"> ● Vehicle stopped ● Engine running ● A/T selector lever "P" position ● Brake pedal depressed 	4WD shift switch : 4H to 4LO or 4LO to 4H (While actuator motor is operating.)	ON
		Except the above	OFF	
WAIT DETCT SW [ON/OFF]	Condition of wait detection switch	<ul style="list-style-type: none"> ● Vehicle stopped ● Engine running ● A/T selector lever "N" position ● Brake pedal depressed 	4WD shift switch : 4H and 4LO	ON
		4WD shift switch: 2WD	OFF	
4WD MODE [2H/4H/4L]	Control status of 4WD (Output condition of 4WD shift indicator lamp and 4LO indicator lamp)	4WD shift switch (Engine running)	2WD	2H
			4H	4H
			4LO	4L
VHCL/S COMP [km/h] or [mph]	Vehicle speed	Vehicle stopped	0 km/h (0 mph)	
		Vehicle running CAUTION: Check air pressure of tire under standard condition.	Approximately equal to the indication on speedometer (Inside of ±10%)	
SHIFT ACT 1 [ON/OFF]	Output condition to actuator motor (clockwise)	<ul style="list-style-type: none"> ● Vehicle stopped ● Engine running ● A/T selector lever "N" position ● Brake pedal depressed 	4WD shift switch : 4H to 4LO	ON
		Except the above	OFF	
SHIFT AC MON1 [ON/OFF]	Check signal (reinput signal) for transfer control unit signal output	<ul style="list-style-type: none"> ● Vehicle stopped ● Engine running ● A/T selector lever "N" position ● Brake pedal depressed 	4WD shift switch : 4H to 4LO	ON
		Except the above	OFF	
SHIFT ACT 2 [ON/OFF]	Output condition to actuator motor (counterclockwise)	<ul style="list-style-type: none"> ● Vehicle stopped ● Engine running ● A/T selector lever "N" position ● Brake pedal depressed 	4WD shift switch : 4LO to 4H	ON
		Except the above	OFF	
SHIFT AC MON2 [ON/OFF]	Check signal (reinput signal) for transfer control unit signal output	<ul style="list-style-type: none"> ● Vehicle stopped ● Engine running ● A/T selector lever "N" position ● Brake pedal depressed 	4WD shift switch : 4LO to 4H	ON
		Except the above	OFF	

TROUBLE DIAGNOSIS

Monitored item [Unit]	Content	Condition		Display value
SHIFT ACT/R MON [ON/OFF]	Operating condition of actuator motor relay (integrated in transfer control unit)	<ul style="list-style-type: none"> Vehicle stopped Engine running A/T selector lever "N" position Brake pedal depressed 	When 4WD shift switch is operated	ON
			When 4WD shift switch is not operated	OFF
SHIFT POS SW1 [ON/OFF]	Condition of actuator position switch 1	4WD shift switch: 2WD and 4LO		ON
		4WD shift switch: 4H		OFF
SHIFT POS SW2 [ON/OFF]	Condition of actuator position switch 2	4WD shift switch: 4LO		ON
		4WD shift switch: 2WD and 4H		OFF
SHIFT POS SW3 [ON/OFF]	Condition of actuator position switch 3	4WD shift switch: 2WD and 4H		ON
		4WD shift switch: 4LO		OFF
SHIFT POS SW4 [ON/OFF]	Condition of actuator position switch 4	4WD shift switch: 4H and 4LO		ON
		4WD shift switch: 2WD		OFF
4WD FAIL LAMP [ON/OFF]	4WD warning lamp condition	4WD warning lamp: ON		ON
		4WD warning lamp: OFF		OFF
2WD IND [ON/OFF]	Rear indicator of 4WD shift indicator lamp condition	Rear indicator of 4WD shift indicator lamp: ON		ON
		Rear indicator of 4WD shift indicator lamp: OFF		OFF
4H IND [ON/OFF]	Front and center indicator of 4WD shift indicator lamp condition	Front and center indicator of 4WD shift indicator lamp : ON		ON
		Front and center indicator of 4WD shift indicator lamp : OFF		OFF
4L IND [ON/OFF]	4LO indicator lamp condition	4LO indicator lamp: ON		ON
		4LO indicator lamp: OFF		OFF

Specifications between transfer control unit terminals

TRANSFER CONTROL UNIT TERMINAL CONNECTOR LAYOUT

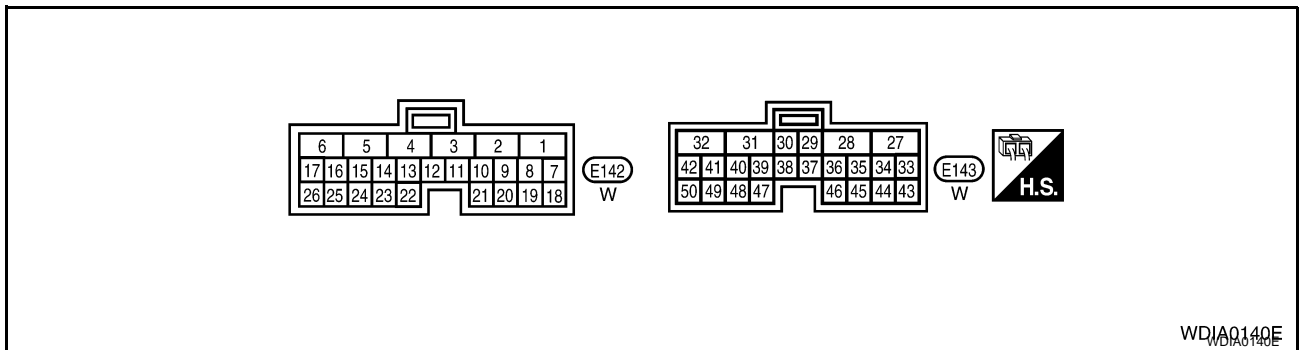

NOTE:

Data are reference value and are measured between each terminal and ground.

Terminal	Wire color	Item	Condition	Data (Approx.)
1	L	CAN-H	-	-
2	P	CAN-L	-	-
3	L	K-LINE (CONSULT-II signal)	-	-
6	B	Ground	Always	0V
10	LG/B	Actuator position switch 1	4WD shift switch: 2WD and 4LO	0V
			4WD shift switch: 4H	Battery voltage
11	W/L	Actuator position switch 2	4WD shift switch: 4LO	0V
			4WD shift switch: 2WD and 4H	Battery voltage

TROUBLE DIAGNOSIS

Terminal	Wire color	Item	Condition	Data (Approx.)	
12	BR	Actuator position switch 3	4WD shift switch: 2WD and 4H	0V	
			4WD shift switch: 4LO	Battery voltage	
13	BR/W	Actuator position switch 4	4WD shift switch: 4H and 4LO	0V	
			4WD shift switch: 2WD	Battery voltage	
14	G/W	4WD shift switch (2WD)	4WD shift switch: 2WD	Battery voltage	
			4WD shift switch: 4H and 4LO	0V	
15	O	4WD shift switch (4H)	4WD shift switch: 4H	Battery voltage	
			4WD shift switch: 2WD and 4LO	0V	
16	R	4WD shift switch (4LO)	4WD shift switch: 4LO	Battery voltage	
			4WD shift switch: 2WD and 4H	0V	
17	G/Y	Wait detection switch	<ul style="list-style-type: none"> ● Vehicle stopped ● Engine running ● A/T selector lever "N" position ● Brake pedal depressed 	4WD shift switch: 4H and 4LO	0V
			4WD shift switch: 2WD	Battery voltage	
18	B	Ground	Always	0V	
19	W	Power supply (Memory back-up)	Ignition switch: ON	Battery voltage	
			Ignition switch: OFF	Battery voltage	
23	R/B	ATP switch	<ul style="list-style-type: none"> ● Vehicle stopped ● Engine running ● A/T selector lever "P" position ● Brake pedal depressed 	4WD shift switch: 4H to 4LO or 4LO to 4H (While actuator motor is operating.)	0V
			Except the above	Battery voltage	
24	V	4LO switch	<ul style="list-style-type: none"> ● Vehicle stopped ● Engine running ● A/T selector lever "N" position ● Brake pedal depressed 	4WD shift switch: 4LO	0V
			Except the above	Battery voltage	
25	L/W	Ignition switch monitor	Ignition switch: ON	Battery voltage	
			Ignition switch: OFF	0V	
27	Y/R	Actuator motor power supply	Ignition switch: ON	Battery voltage	
			Ignition switch: OFF	0V	
28	Y/L	Actuator motor (+)	4WD shift switch: 2WD to 4H or 4H to 4LO or 2WD to 4LO	Battery voltage	
			Except the above	0V	
31	G/B	Actuator motor (-)	4WD shift switch: 4LO to 4H or 4H to 2WD or 4LO to 2WD	Battery voltage	
			Except the above	0V	
32	B	Actuator motor ground	Always	0V	

TROUBLE DIAGNOSIS

Terminal	Wire color	Item	Condition	Data (Approx.)
35	B/W	4WD shift indicator lamp (Rear indicator)	Rear indicator of 4WD shift indicator lamp : ON	0V
			Rear indicator of 4WD shift indicator lamp : OFF	Battery voltage
36	L	4WD shift indicator lamp (Front and center indicator)	Engine running Front and center indicator of 4WD shift indicator lamp: ON	0V
			Front and center indicator of 4WD shift indicator lamp: OFF	Battery voltage
37	W/G	4LO indicator lamp	4LO indicator lamp: ON	0V
			4LO indicator lamp: OFF	Battery voltage
38	W/B	4WD warning lamp	4WD warning lamp: ON	0V
			4WD warning lamp: OFF	Battery voltage
39	L/B	ATP warning lamp	<ul style="list-style-type: none"> ● Vehicle stopped ● Engine running ● A/T selector lever "P" position ● Brake pedal depressed 4WD shift switch: 4H to 4LO or 4LO to 4H (While actuator motor is operating.)	Battery voltage
			Except the above	0V
40	Y	Transfer relay 2	ignition switch ON	0V
			ignition switch OFF	Battery voltage
44	Y/R	Power supply	Ignition switch: ON	Battery voltage
			Ignition switch: OFF	0V
45	Y/R	Power supply	Ignition switch: ON	Battery voltage
			Ignition switch: OFF	0V

CAUTION:

When using a circuit tester to measure voltage for inspection, be sure not to extend forcibly any connector terminals.

CONSULT-II Function (ALL MODE AWD/4WD) FUNCTION

EDS001N1

CONSULT-II can display each diagnostic item using the diagnostic test modes shown following.

ALL MODE AWD/4WD diagnostic mode	Description
SELF-DIAG RESULTS	Displays transfer control unit self-diagnosis results.
DATA MONITOR	Displays transfer control unit input/output data in real time.
CAN DIAG SUPPORT MNTR	The results of transmit/receive diagnosis of CAN communication can be read.
ECU PART NUMBER	Transfer control unit part number can be read.

CONSULT-II SETTING PROCEDURE

CAUTION:

If CONSULT-II is used with no connection of CONSULT-II CONVERTER, malfunctions might be detected in self-diagnosis depending on control unit which carry out CAN communication.

NOTE:

For details, refer to the separate "CONSULT-II Operations Manual".

1. Turn ignition switch "OFF".

TROUBLE DIAGNOSIS

2. Connect CONSULT-II and CONSULT-II CONVERTER to data link connector on vehicle.
3. Turn ignition switch "ON".

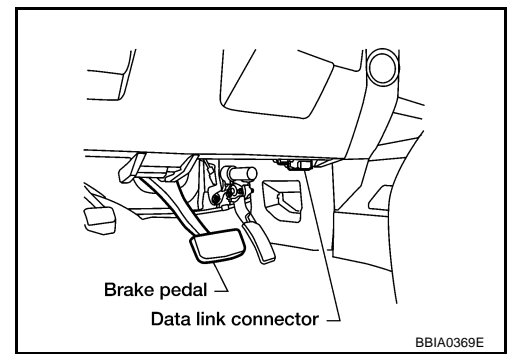

4. Touch "START (NISSAN BASED VHCL)".

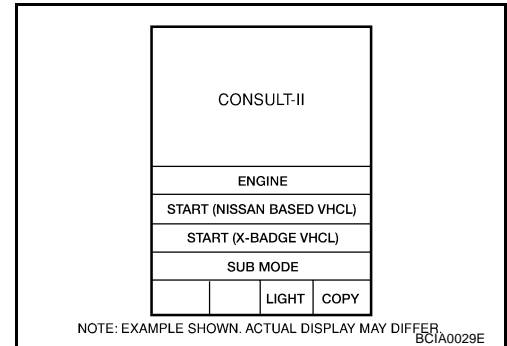

5. Touch "ALL MODE AWD/4WD".
If "ALL MODE AWD/4WD" is not indicated, go to [GI-39, "CONSULT-II Data Link Connector \(DLC\) Circuit"](#).
6. Perform each diagnostic test mode according to each service procedure.

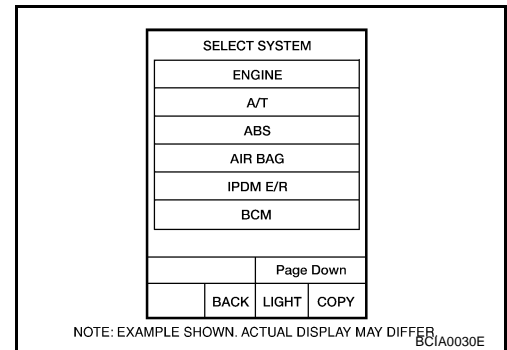

TROUBLE DIAGNOSIS

SELF-DIAG RESULT MODE

Operation Procedure

1. Perform "CONSULT-II SETTING PROCEDURE". Refer to [TF-31, "CONSULT-II SETTING PROCEDURE"](#).
2. With engine at idle, touch "SELF-DIAG RESULTS".
Display shows malfunction experienced since the last erasing operation.

NOTE:

- The details for "TIME" are as follow:
 - "0": Error currently detected with transfer control unit.
 - Except for "0": Error detected in the past and memorized with transfer control unit.
Detects frequency of driving after DTC occurs (frequency of turning ignition switch "ON/OFF").

SELF-DIAG RESULTS	
DTC RESULTS	TIME
CAN COMM CIRCUIT [U1000]	0
SHIFT ACT POSI SW [P1818]	1
ERASE	PRINT

SDIA2687E

Display item list

Items (CONSULT-II screen terms)	Diagnostic item is detected when...	Check item
INITIAL START [P1801]	<ul style="list-style-type: none"> ● Due to removal of battery which cuts off power supply to transfer control unit, self-diagnosis memory function is suspended. 	TF-38, "Power Supply Circuit For Transfer Control Unit"
CONTROL UNIT 1 [P1802]	<ul style="list-style-type: none"> ● Malfunction is detected in the memory (RAM) system of transfer control unit. 	TF-40, "Transfer Control Unit"
CONTROL UNIT 2 [P1803]	<ul style="list-style-type: none"> ● Malfunction is detected in the memory (ROM) system of transfer control unit. 	TF-40, "Transfer Control Unit"
CONTROL UNIT 3 [P1804]	<ul style="list-style-type: none"> ● Malfunction is detected in the memory (EEPROM) system of transfer control unit. 	TF-40, "Transfer Control Unit"
VHCL SPEED SEN-AT [P1807]	<ul style="list-style-type: none"> ● Malfunction is detected in output shaft revolution signal that is output from TCM through CAN communication. ● Improper signal is input while driving. 	TF-41, "Output Shaft Revolution Signal (TCM)"
VHCL SPEED SEN-ABS [P1808]	<ul style="list-style-type: none"> ● Malfunction is detected in vehicle speed signal that is output from ABS actuator and electric unit (control unit) through CAN communication. ● Improper signal is input while driving. 	TF-42, "Vehicle Speed Sensor (ABS)"
CONTROL UNIT 4 [P1809]	<ul style="list-style-type: none"> ● AD converter system of transfer control unit is malfunctioning. 	TF-40, "Transfer Control Unit"
4L POSI SW TF [P1810]	<ul style="list-style-type: none"> ● Improper signal from 4LO switch is input due to open or short circuit. 	TF-42, "4LO Switch"
BATTERY VOLTAGE [P1811]	<ul style="list-style-type: none"> ● Power supply voltage for transfer control unit is abnormally low while driving. 	TF-38, "Power Supply Circuit For Transfer Control Unit"
4WD MODE SW [P1813]	<ul style="list-style-type: none"> ● More than two switch inputs are simultaneously detected due to short circuit of 4WD shift switch. 	TF-45, "4WD Shift Switch"
4WD DETECT SWITCH [P1814]	<ul style="list-style-type: none"> ● Improper signal from wait detection switch is input due to open or short circuit. 	TF-49, "Wait Detection Switch"
PNP SW/CIRC [P1816]	<ul style="list-style-type: none"> ● When A/T PNP switch signal is malfunction or communication error between the vehicles. 	TF-52, "PNP Switch Signal (TCM)"
SHIFT ACTUATOR [P1817]	<ul style="list-style-type: none"> ● Motor does not operate properly due to open or short circuit in actuator motor. ● Malfunction is detected in the actuator motor. (When 4WD shift switch is operated and actuator motor is not operated) 	TF-53, "Actuator Motor"
SHIFT ACT POSI SW [P1818]	<ul style="list-style-type: none"> ● Improper signal from actuator position switch is input due to open or short circuit. ● Malfunction is detected in the actuator position switch. 	TF-57, "Actuator Position Switch"
SHIFT ACT CIR [P1819]	<ul style="list-style-type: none"> ● Malfunction is detected in the transfer relay 2. ● Malfunction occurs in transfer control device drive circuit. 	TF-38, "Power Supply Circuit For Transfer Control Unit", TF-60, "Transfer Control Device"

TROUBLE DIAGNOSIS

Items (CONSULT-II screen terms)	Diagnostic item is detected when...	Check item
ENGINE SPEED SIG [P1820]	<ul style="list-style-type: none"> ● Malfunction is detected in engine speed signal that is output from ECM through CAN communication. ● Improper signal is input while driving. 	TF-63. "Engine Speed Signal (ECM)"
CAN COMM CIRCUIT [U1000]	<ul style="list-style-type: none"> ● Malfunction has been detected from CAN communication line. 	TF-64. "CAN Communication Line"
NO DTC IS DETECTED. FURTHER TESTING MAY BE REQUIRED.	<ul style="list-style-type: none"> ● No NG item has been detected. 	—

CAUTION:

If "CAN COMM CIRCUIT [U1000]" is displayed with other DTCs, first perform the trouble diagnosis for CAN communication line.

NOTE:

If "SHIFT ACT POSI SW [P1818]" or "SHIFT ACT CIR [P1819]" is displayed, first erase self-diagnostic results. ("SHIFT ACT POSI SW [P1818]" or "SHIFT ACT CIR [P1819]" may be displayed after installing transfer control unit or transfer assembly.)

How to erase self-diagnostic results

1. Perform applicably inspection of malfunctioning item and then repair or replace.
2. Start engine and select "SELF-DIAG RESULTS" mode for "ALL MODE AWD/4WD" with CONSULT-II.
3. Touch "ERASE" on CONSULT-II screen to erase DTC memory.

CAUTION:

If memory cannot be erased, perform applicably diagnosis.

DATA MONITOR MODE

Operation procedure

1. Perform "CONSULT-II SETTING PROCEDURE". Refer to [TF-31. "CONSULT-II SETTING PROCEDURE"](#).
2. Touch "DATA MONITOR".
3. Select from "SELECT MONITOR ITEM", screen of data monitor mode is displayed.

NOTE:

When malfunction is detected, CONSULT-II performs REAL-TIME DIAGNOSIS. Also, any malfunction detected while in this mode will be displayed at real time.

Display item list

x: Standard -: Not applicable

Monitored item (Unit)	Monitor item selection			Remarks
	ECU INPUT SIGNALS	MAIN SIGNALS	SELECTION FROM MENU	
VHCL/S SEN-FR [km/h] or [mph]	x	-	x	Wheel speed calculated by ABS actuator and electric unit (control unit). Signal input with CAN communication line.
VHCL/S SEN-RR [km/h] or [mph]	x	-	x	Wheel speed calculated by TCM. Signal input with CAN communication line.
ENGINE SPEED [rpm]	x	-	x	Engine speed is displayed. Signal input with CAN communication line.
BATTERY VOLT [V]	x	-	x	Power supply voltage for transfer control unit.
2WD SWITCH [ON/OFF]	x	-	x	4WD shift switch signal status is displayed. (4L means 4LO of 4WD shift switch.)
4H SWITCH [ON/OFF]	x	-	x	
4L SWITCH [ON/OFF]	x	-	x	

TROUBLE DIAGNOSIS

Monitored item (Unit)	Monitor item selection			Remarks
	ECU INPUT SIGNALS	MAIN SIGNALS	SELECTION FROM MENU	
4L POSI SW [ON/OFF]	×	-	×	This means 4LO switch. 4LO switch signal status is displayed.
ATP SWITCH [ON/OFF]	×	-	×	ATP switch signal status is displayed.
WAIT DETCT SW [ON/OFF]	×	-	×	Wait detection switch signal status is displayed.
4WD MODE [2H/4H/4L]	-	×	×	Control status of 4WD recognized by transfer control unit. (2WD, 4H or 4LO)
VHCL/S COMP [km/h] or [mph]	-	×	×	Vehicle speed recognized by transfer control unit.
SHIFT ACT 1 [ON/OFF]	-	×	×	Output condition to actuator motor (clockwise)
SHIFT ACT MON 1 [ON/OFF]	-	-	×	Check signal (reinput signal) for transfer control unit signal output
SHIFT ACT 2 [ON/OFF]	-	×	×	Output condition to actuator motor (counterclockwise)
SHIFT ACT MON 2 [ON/OFF]	-	-	×	Check signal (reinput signal) for transfer control unit signal output
SFT ACT/R MON [ON/OFF]	-	-	×	Operating condition of actuator motor relay (integrated in transfer control unit)
SHIFT POS SW 1 [ON/OFF]	×	-	×	Condition of actuator position switch 1
SHIFT POS SW 2 [ON/OFF]	×	-	×	Condition of actuator position switch 2
SHIFT POS SW 3 [ON/OFF]	×	-	×	Condition of actuator position switch 3
SHIFT POS SW 4 [ON/OFF]	×	-	×	Condition of actuator position switch 4
4WD FAIL LAMP [ON/OFF]	-	×	×	Control status of 4WD warning lamp is displayed.
2WD IND [ON/OFF]	-	-	×	Control status of 4WD shift indicator lamp (rear) is displayed.
4H IND [ON/OFF]	-	-	×	Control status of 4WD shift indicator lamp (front and center) is displayed.
4L IND [ON/OFF]	-	-	×	Control status of 4LO indicator lamp is displayed.
Voltage [V]	-	-	×	The value measured by the voltage probe is displayed.
Frequency [Hz]	-	-	×	The value measured by the pulse probe is displayed.
DUTY-HI (high) [%]	-	-	×	
DUTY-LOW (low) [%]	-	-	×	
PLS WIDTH-HI [msec]	-	-	×	
PLS WIDTH-LOW [msec]	-	-	×	

A
B
C
TF
E
F
G
H
I
J
K
L
M

TROUBLE DIAGNOSIS

EDS001N2

Self-Diagnostic Procedure

① SELF-DIAGNOSTIC PROCEDURE (WITH CONSULT-II)

Refer to [TF-33, "SELF-DIAG RESULT MODE"](#) .

② SELF-DIAGNOSTIC PROCEDURE (WITHOUT CONSULT-II)

Description

If the engine starts when there is something wrong with the 4WD system, the 4WD warning lamp turns ON or flickers in the combination meter. When the system functions properly, the warning lamp turns ON when the ignition switch is turned to "ON", and it turns OFF after engine starts. To locate the cause of a problem, start the self-diagnosis function. The 4WD warning lamp in the combination meter will indicate the problem area by flickering according to the self-diagnostic results. As for the details of the 4WD warning lamp flickering patterns, refer to [TF-36, "Diagnostic procedure"](#) .

Diagnostic procedure

1. Warm up engine.
2. Turn ignition switch "ON" and "OFF" at least twice, and then turn ignition switch "OFF".
3. Move A/T selector lever to "P" position.
4. Turn 4WD shift switch to "2WD" position.
5. Turn ignition switch "ON". (Do not start engine.)
6. 4WD warning lamp ON.
If 4WD warning lamp does not turn ON, refer to [TF-71, "4WD Warning Lamp Does Not Turn ON"](#) .
7. Move A/T selector lever to "R" position.
8. Turn 4WD shift switch to "2WD", "4H" and "2WD" in order.
9. Move A/T selector lever to "P" position.
10. Turn 4WD shift switch to "4H", "2WD" and "4H" in order.
11. Move A/T selector lever to "N" position.
12. Turn 4WD shift switch to "2WD" position.
13. Move A/T selector lever to "P" position.
14. Read the flickering of 4WD warning lamp.
Refer to [TF-36, "Judgement self-diagnosis"](#) .

Judgement self-diagnosis

When a malfunction is detected, the malfunction route is indicated by flickering of the 4WD warning lamp.

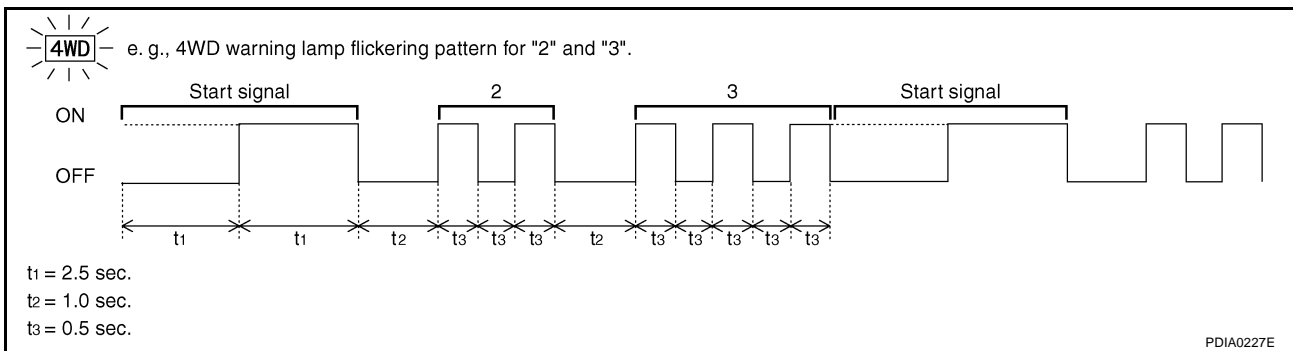

Flickering pattern or flickering condition	Items	Diagnostic item is detected when...	Check item
2	Output shaft revolution signal (from TCM)	<ul style="list-style-type: none"> ● Malfunction is detected in output shaft revolution signal that is output from TCM through CAN communication. ● Improper signal is input while driving. 	TF-41, "Output Shaft Revolution Signal (TCM)"
3	Vehicle speed signal (from ABS)	<ul style="list-style-type: none"> ● Malfunction is detected in vehicle speed signal that is output from ABS actuator and electric unit (control unit) through CAN communication. ● Improper signal is input while driving. 	TF-42, "Vehicle Speed Sensor (ABS)"
4	CAN communication	Malfunction has been detected from CAN communication.	TF-64, "CAN Communication Line"

TROUBLE DIAGNOSIS

Flickering pattern or flickering condition	Items	Diagnostic item is detected when...	Check item	
5	AD converter	AD converter system of transfer control unit is malfunctioning.	TF-40, "Transfer Control Unit"	A
6	4LO switch	Improper signal from 4LO switch is input due to open or short circuit.	TF-42, "4LO Switch"	B
7	Engine speed signal	<ul style="list-style-type: none"> Malfunction is detected in engine speed signal that is output from ECM through CAN communication. Improper signal is input while driving. 	TF-63, "Engine Speed Signal (ECM)"	C
8	Power supply	Power supply voltage for transfer control unit is abnormally low while driving.	TF-38, "Power Supply Circuit For Transfer Control Unit"	TF
9	4WD shift switch	More than two switch inputs are simultaneously detected due to short circuit of 4WD shift switch.	TF-45, "4WD Shift Switch"	E
10	Wait detection switch	Improper signal from wait detection switch is input due to open or short circuit.	TF-49, "Wait Detection Switch"	F
11	Actuator motor	<ul style="list-style-type: none"> Motor does not operate properly due to open or short circuit in actuator motor. Malfunction is detected in the actuator motor. (When 4WD shift switch is operated and actuator motor is not operated.) 	TF-53, "Actuator Motor"	G
12	Actuator position switch	<ul style="list-style-type: none"> Improper signal from actuator position switch is input due to open or short circuit. Malfunction is detected in the actuator position switch. 	TF-57, "Actuator Position Switch"	H
13	Transfer control device	<ul style="list-style-type: none"> Malfunction is detected in the transfer relay 2. Malfunction occurs in transfer control device drive circuit. 	TF-38, "Power Supply Circuit For Transfer Control Unit" , TF-60, "Transfer Control Device"	I
14	PNP switch signal	When A/T PNP switch signal is malfunction or communication error between the vehicles.	TF-52, "PNP Switch Signal (TCM)"	J
Repeats flickering every 0.25 sec.	Data erase display	<ul style="list-style-type: none"> Power supply failure of memory back-up. Battery is disconnected for a long time. Battery performance is poor. 	TF-38, "Power Supply Circuit For Transfer Control Unit"	K
Repeats flickering every 2 to 5 sec.	—	Circuits that the self-diagnosis covers have no malfunction.	—	L
No flickering	PNP switch or 4WD shift switch	PNP switch or 4WD shift switch circuit is shorted or open.	TF-52, "PNP Switch Signal (TCM)" or TF-45, "4WD Shift Switch"	M

NOTE:

If "actuator position switch" or "transfer control device" is displayed, first erase self-diagnostic results. (They may be displayed after installing transfer control unit or transfer assembly.)

ERASE SELF-DIAGNOSIS

- In order to make it easier to find the cause of hard-to-duplicate malfunctions, malfunction information is stored into the control unit as necessary during use by the user. This memory is not erased no matter how many times the ignition switch is turned ON and OFF.
- However, this information is erased by turning ignition switch "OFF" after performing self-diagnostics or by erasing the memory using the CONSULT-II.

TROUBLE DIAGNOSIS FOR SYSTEM

TROUBLE DIAGNOSIS FOR SYSTEM

PFP:00000

Power Supply Circuit For Transfer Control Unit CONSULT-II REFERENCE VALUE IN DATA MONITOR MODE

EDS001N3

Data are reference value.

Monitored item [Unit]	Content	Condition	Display value
BATTERY VOLT [V]	Power supply voltage for transfer control unit	Ignition switch: ON	Battery voltage

TRANSFER CONTROL UNIT TERMINALS AND REFERENCE VALUE

Data are reference value and are measured between each terminal and ground.

Terminal	Wire color	Item	Condition	Data (Approx.)
6	B	Ground	Always	0V
18	B	Ground	Always	0V
19	W	Power supply (Memory back-up)	Ignition switch: ON	Battery voltage
			Ignition switch: OFF	Battery voltage
25	L/W	Ignition switch monitor	Ignition switch: ON	Battery voltage
			Ignition switch: OFF	0V
32	B	Actuator motor ground	Always	0V
40	Y	Transfer relay 2	Ignition switch: ON	0V
			Ignition switch: OFF	Battery voltage
44	Y/R	Power supply	Ignition switch: ON	Battery voltage
			Ignition switch: OFF	0V
45	Y/R	Power supply	Ignition switch: ON	Battery voltage
			Ignition switch: OFF	0V

CAUTION:

When using a circuit tester to measure voltage for inspection, be sure not to extend forcibly any connector terminals.

TROUBLE DIAGNOSIS FOR SYSTEM

DIAGNOSTIC PROCEDURE

1. CHECK POWER SUPPLY

1. Turn ignition switch "OFF".
2. Disconnect transfer control unit harness connector.
3. Check voltage between transfer control unit harness connector terminals and ground.

Connector	Terminal (Wire color)	Voltage (Approx.)
E142	19 (W) - Ground	Battery voltage
	25 (L/W) - Ground	0V
E143	40 (Y) - Ground	Battery voltage
	44 (Y/R) - Ground	0V
	45 (Y/R) - Ground	

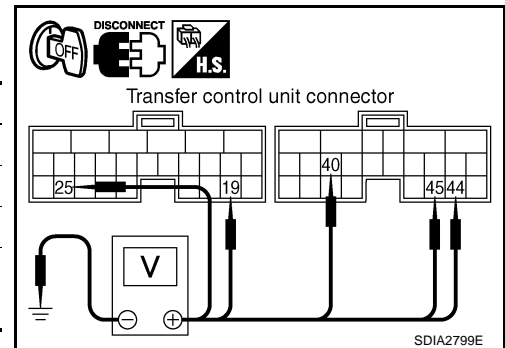

4. Turn ignition switch "ON". (Do not start engine.)
5. Check voltage between transfer control unit harness connector terminals and ground.

Connector	Terminal (Wire color)	Voltage (Approx.)
E142	19 (W) - Ground	Battery voltage
	25 (L/W) - Ground	
E143	40 (Y) - Ground	
	44 (Y/R) - Ground	
	45 (Y/R) - Ground	

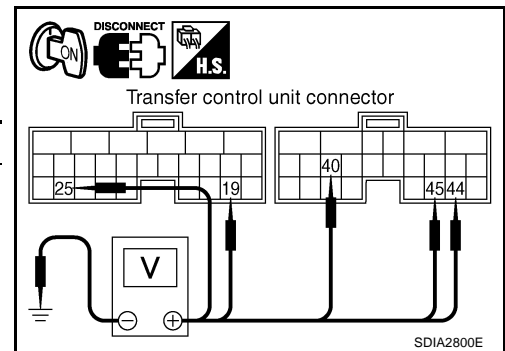

OK or NG

OK >> GO TO 2.

NG >> Check the following. If any items are damaged, repair or replace damaged parts.

- 10A fuses [No. 26 located in the fuse and fusible link box or 59 located in the fuse and relay box]
- 20A fuse [No. 53, located in the IPDM E/R]
- Harness for short or open between battery and transfer control unit harness connector E142 terminal 19 (W), and connector E143 terminals 40 (Y), 44 (Y/R) and 45 (Y/R)
- Harness for short or open between ignition switch and transfer control unit harness connector E142 terminal 25 (L/W)
- Harness for short or open between ignition switch and transfer relay 1 harness connector E46 terminal 2 (L/W)
- Harness for short or open between transfer relay 1 harness connector E46 terminal 1 (B) and ground
- Battery and ignition switch. Refer to [PG-4, "POWER SUPPLY ROUTING CIRCUIT"](#) .
- Transfer relay 1, 2. Refer to [TF-40, "COMPONENT INSPECTION"](#) .

TROUBLE DIAGNOSIS FOR SYSTEM

2. CHECK GROUND CIRCUIT

1. Turn ignition switch "OFF".
2. Disconnect transfer control unit harness connector.
3. Check continuity between transfer control unit harness connector E142 terminals 6 (B), 18 (B), E143 terminal 32 (B) and ground.

Continuity should exist.

Also check harness for short to power.

OK or NG

OK >> GO TO 3.

NG >> Repair open circuit or short to power in harness or connectors.

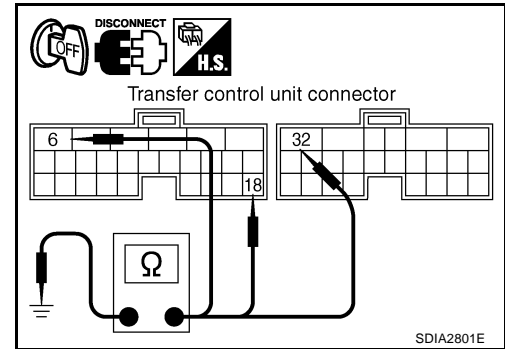

3. CHECK TRANSFER CONTROL UNIT

Check transfer control unit input/output signal. Refer to [TF-27, "Transfer Control Unit Input/Output Signal Reference Values"](#).

OK or NG

OK >> GO TO 4.

NG >> Check transfer control unit pin terminals for damage or loose connection with harness connector. If any items are damaged, repair or replace damaged parts.

4. CHECK DTC

Perform the self-diagnosis, after driving a vehicle for a while.

OK or NG

OK >> Inspection End.

NG >> Replace transfer control unit. Refer to [TF-79, "Removal and Installation"](#).

COMPONENT INSPECTION

1. Apply 12V direct current between terminals 1 and 2 of transfer relay 1 and 2.
2. Check continuity between relay terminals 3 and 5.

Condition	Continuity
12V direct current supply between terminals 1 and 2	Yes
OFF	No

3. If NG, replace the transfer relay 1 or 2. Refer to [TF-21, "Location of Electrical Parts"](#).

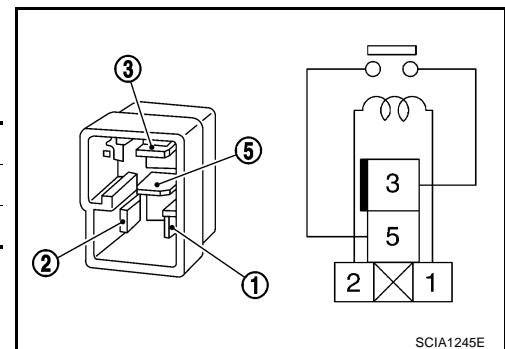

Transfer Control Unit DIAGNOSTIC PROCEDURE

1. INSPECTION START

Do you have CONSULT-II?

YES or NO

YES >> GO TO 2.

NO >> GO TO 3.

TROUBLE DIAGNOSIS FOR SYSTEM

2. PERFORM SELF-DIAGNOSIS (WITH CONSULT-II)

With CONSULT-II

1. Turn ignition switch "ON". (Do not start engine.)
2. Select "SELF-DIAG RESULTS" mode for "ALL MODE AWD/4WD" with CONSULT-II.
3. Touch "ERASE".
4. Turn ignition switch "OFF" and wait at least 10 seconds.
5. Perform the self-diagnosis again.

Is the "CONTROL UNIT 1 [P1802]", "CONTROL UNIT 2 [P1803]", "CONTROL UNIT 3 [P1804]" or "CONTROL UNIT 4 [P1809]" displayed?

- YES >> Replace transfer control unit. Refer to [TF-79, "TRANSFER CONTROL UNIT"](#) .
NO >> Inspection End.

3. PERFORM SELF-DIAGNOSIS (WITHOUT CONSULT-II)

Without CONSULT-II

1. Perform the self-diagnosis and then erase self-diagnostic results. Refer to [TF-36, "SELF-DIAGNOSTIC PROCEDURE \(WITHOUT CONSULT-II\)"](#) and [TF-37, "ERASE SELF-DIAGNOSIS"](#) .
2. Perform the self-diagnosis again.

Do the self-diagnostic results indicate AD converter?

- YES >> Replace transfer control unit. Refer to [TF-79, "TRANSFER CONTROL UNIT"](#) .
NO >> Inspection End.

Output Shaft Revolution Signal (TCM) DIAGNOSTIC PROCEDURE

EDS001N5

1. CHECK DTC WITH TCM

Perform self-diagnosis with TCM. Refer to [AT-88, "CONSULT-II SETTING PROCEDURE"](#) .

Is any malfunction detected by self-diagnosis?

- YES >> Check the malfunctioning system.
NO >> GO TO 2.

2. CHECK TRANSFER CONTROL UNIT

Check transfer control unit input/output signal. Refer to [TF-27, "Transfer Control Unit Input/Output Signal Reference Values"](#) .

OK or NG

- OK >> GO TO 3.
NG >> Check transfer control unit pin terminals for damage or loose connection with harness connector. If any items are damaged, repair or replace damaged parts.

3. CHECK DTC

Perform the self-diagnosis, after driving a vehicle for a while.

OK or NG

- OK >> Inspection End.
NG >> Perform self-diagnosis with TCM again. Refer to [AT-88, "SELF-DIAGNOSTIC RESULT MODE"](#) .

TROUBLE DIAGNOSIS FOR SYSTEM

EDS001N6

Vehicle Speed Sensor (ABS) DIAGNOSTIC PROCEDURE

1. CHECK DTC WITH ABS ACTUATOR AND ELECTRIC UNIT (CONTROL UNIT)

Perform self-diagnosis with ABS actuator and electric unit (control unit). Refer to [BRC-64, "SELF-DIAGNOSIS"](#) (without VDC) or [BRC-115, "SELF-DIAGNOSIS"](#) (with VDC).

Is any malfunction detected by self-diagnosis?

- YES >> Check the malfunctioning system.
- NO >> GO TO 2.

2. CHECK TRANSFER CONTROL UNIT

Check transfer control unit input/output signal. Refer to [TF-27, "Transfer Control Unit Input/Output Signal Reference Values"](#).

OK or NG

- OK >> GO TO 3.
- NG >> Check transfer control unit pin terminals for damage or loose connection with harness connector. If any items are damaged, repair or replace damaged parts.

3. CHECK DTC

Perform the self-diagnosis, after driving a vehicle for a while.

OK or NG

- OK >> Inspection End.
- NG >> Perform self-diagnosis with ABS actuator and electric unit (control unit) again. Refer to [BRC-24, "SELF-DIAGNOSIS"](#) (without VDC) or [BRC-24, "SELF-DIAGNOSIS"](#) (with VDC).

4LO Switch

EDS001N7

CONSULT-II REFERENCE VALUE IN DATA MONITOR MODE

Data are reference value.

Monitored item	Content	Condition	Display value
4L POSI SW [ON/OFF]	Condition of 4LO switch	<ul style="list-style-type: none"> ● Vehicle stopped ● Engine running ● A/T selector lever "N" position ● Brake pedal depressed 	4WD shift switch: 4LO ON
		Except the above	OFF

TRANSFER CONTROL UNIT TERMINALS AND REFERENCE VALUE

Data are reference value and are measured between each terminal and ground.

Terminal	Wire color	Item	Condition	Data (Approx.)
24	V	4LO switch	<ul style="list-style-type: none"> ● Vehicle stopped ● Engine running ● A/T selector lever "N" position ● Brake pedal depressed 	4WD shift switch: 4LO 0V
			Except the above	Battery voltage

CAUTION:

When using a circuit tester to measure voltage for inspection, be sure not to extend forcibly any connector terminals.

TROUBLE DIAGNOSIS FOR SYSTEM

DIAGNOSTIC PROCEDURE

1. CHECK 4LO POSITION SWITCH SIGNAL

With CONSULT-II

1. Start engine.
2. Select "DATA MONITOR" mode for "ALL MODE AWD/4WD" with CONSULT-II.
3. Read out the value of "4L POSI SW".

Condition		Display value
<ul style="list-style-type: none"> ● Vehicle stopped ● Engine running ● A/T selector lever "N" position ● Brake pedal depressed 	4WD shift switch: 4LO	ON
	Except the above	OFF

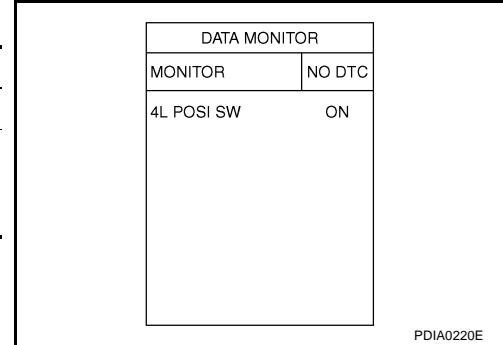

Without CONSULT-II

1. Start engine.
2. Check voltage between transfer control unit harness connector terminal and ground.

Connector	Terminal (Wire color)	Condition	Voltage (Approx.)
E142	24 (V) - Ground	<ul style="list-style-type: none"> ● Vehicle stopped ● Engine running ● A/T selector lever "N" position ● Brake pedal depressed 	4WD shift switch: 4LO
		Except the above	Battery voltage

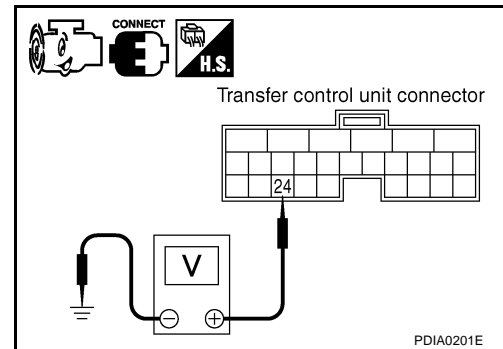

OK or NG

- OK >> GO TO 5.
- NG >> GO TO 2.

2. CHECK HARNESS BETWEEN TRANSFER CONTROL UNIT AND 4LO SWITCH

1. Turn ignition switch "OFF".
2. Disconnect transfer control unit harness connector and the 4LO switch connector.
3. Check continuity between transfer control unit harness connector E142 terminal 24 (V) and 4LO switch harness connector F60 terminal 13 (V).

Continuity should exist.

Also check harness for short to ground and short to power.

OK or NG

- OK >> GO TO 3.
- NG >> Repair or replace damaged parts.

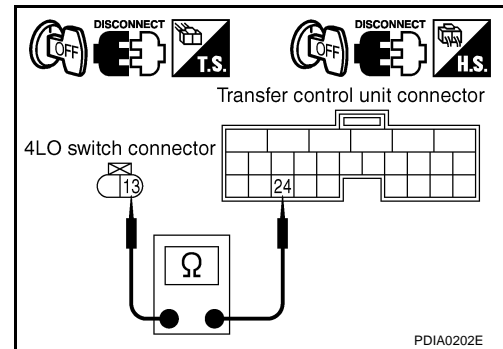

TROUBLE DIAGNOSIS FOR SYSTEM

3. CHECK GROUND CIRCUIT

1. Turn ignition switch "OFF".
2. Disconnect 4LO switch harness connector.
3. Check continuity between 4LO switch harness connector F60 terminal 12 (B) and ground.

Continuity should exist.

Also check harness for short to power.

OK or NG

OK >> GO TO 4.

NG >> Repair open circuit or short to power in harness or connectors.

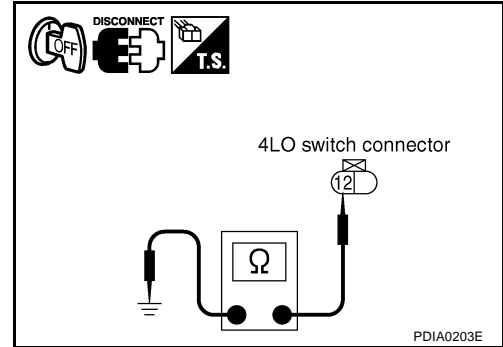

4. CHECK 4LO SWITCH

1. Turn ignition switch "OFF".
2. Disconnect 4LO switch harness connector.
3. Remove 4LO switch. Refer to [TF-21, "Location of Electrical Parts"](#).
4. Push and release 4LO switch and check continuity between 4LO switch terminals 12 and 13.

Terminal	Condition	Continuity
12 - 13	Push 4LO switch	Yes
	Release 4LO switch	No

OK or NG

OK >> GO TO 5.

NG >> Replace 4LO switch. Refer to [TF-21, "Location of Electrical Parts"](#).

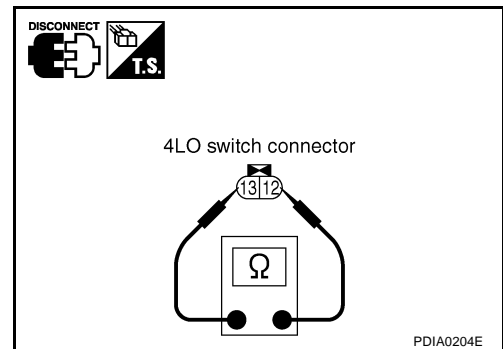

5. CHECK TRANSFER CONTROL UNIT

Check transfer control unit input/output signal. Refer to [TF-27, "Transfer Control Unit Input/Output Signal Reference Values"](#).

OK or NG

OK >> GO TO 6.

NG >> Check transfer control unit pin terminals for damage or loose connection with harness connector. If any items are damaged, repair or replace damaged parts.

6. CHECK DTC

Perform the self-diagnosis, after driving a vehicle for a while.

OK or NG

OK >> Inspection End.

NG >> Replace transfer control unit. Refer to [TF-79, "TRANSFER CONTROL UNIT"](#).

COMPONENT INSPECTION

1. Turn ignition switch "OFF".
2. Disconnect 4LO switch harness connector.
3. Remove 4LO switch. Refer to [TF-21, "Location of Electrical Parts"](#).

TROUBLE DIAGNOSIS FOR SYSTEM

4. Push and release 4LO switch and check continuity between 4LO switch terminals 12 and 13.

Terminal	Condition	Continuity
12 - 13	Push 4LO switch	Yes
	Release 4LO switch	No

5. If NG, replace the 4LO switch. Refer to [TF-21, "Location of Electrical Parts"](#) .

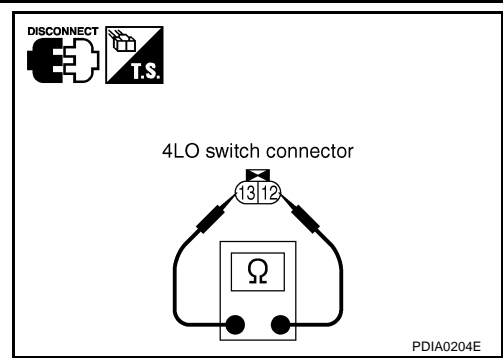

4WD Shift Switch

CONSULT-II REFERENCE VALUE IN DATA MONITOR MODE

Data are reference value.

Monitored item [Unit]	Content	Condition	Display value
2WD SWITCH [ON/OFF]	Input condition from 4WD shift switch	4WD shift switch: 2WD	ON
		4WD shift switch: 4H and 4LO	OFF
4H SWITCH [ON/OFF]	Input condition from 4WD shift switch	4WD shift switch: 4H	ON
		4WD shift switch: 2WD and 4LO	OFF
4L SWITCH [ON/OFF]	Input condition from 4WD shift switch	4WD shift switch: 4LO	ON
		4WD shift switch: 2WD and 4H	OFF
4WD MODE [2H/4H/4L]	Control status of 4WD (Output condition of 4WD shift indicator lamp and 4LO indicator lamp)	4WD shift switch (Engine running)	2WD
			4H
			4LO

TRANSFER CONTROL UNIT TERMINALS AND REFERENCE VALUE

Data are reference value and are measured between each terminal and ground.

Terminal	Wire color	Item	Condition	Data (Approx.)
14	G/W	4WD shift switch (2WD)	4WD shift switch: 2WD	Battery voltage
			4WD shift switch: 4H and 4LO	0V
15	O	4WD shift switch (4H)	4WD shift switch: 4H	Battery voltage
			4WD shift switch: 2WD and 4LO	0V
16	R	4WD shift switch (4LO)	4WD shift switch: 4LO	Battery voltage
			4WD shift switch: 2WD and 4H	0V

CAUTION:

When using a circuit tester to measure voltage for inspection, be sure not to extend forcibly any connector terminals.

TROUBLE DIAGNOSIS FOR SYSTEM

DIAGNOSTIC PROCEDURE

1. CHECK 4WD SHIFT SWITCH SIGNAL

Ⓟ With CONSULT-II

1. Turn ignition switch "ON".
2. Select "DATA MONITOR" mode for "ALL MODE AWD/4WD" with CONSULT-II.
3. Read out ON/OFF switching action of the "2WD SWITCH", "4H SWITCH", "4L SWITCH" with operating 4WD shift switch.

DATA MONITOR	
MONITOR	NO DTC
2WD SWITCH	OFF
4H SWITCH	ON
4L SWITCH	OFF

SDIA2382E

⊗ Without CONSULT-II

1. Turn ignition switch "ON".
2. Check voltage between transfer control unit harness connector terminals and ground.

Connector	Terminal (Wire color)	Condition	Voltage (Approx.)
E142	14 (G/W) - Ground	4WD shift switch: 2WD	Battery voltage
		4WD shift switch: 4H and 4LO	0V
	15 (O) - Ground	4WD shift switch: 4H	Battery voltage
		4WD shift switch: 2WD and 4LO	0V
	16 (R) - Ground	4WD shift switch: 4LO	Battery voltage
		4WD shift switch: 2WD and 4H	0V

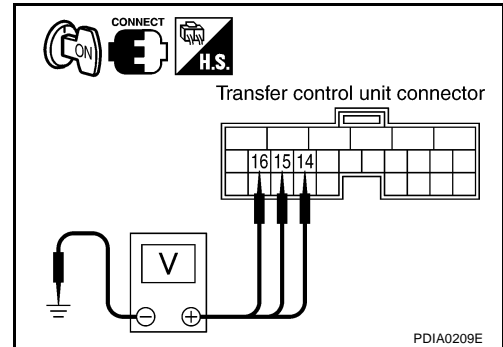

OK or NG

- OK >> GO TO 5.
 NG >> GO TO 2.

TROUBLE DIAGNOSIS FOR SYSTEM

2. CHECK 4WD SHIFT SWITCH POWER SUPPLY CIRCUIT

1. Turn ignition switch "ON".
2. Disconnect 4WD shift switch harness connector.
3. Check voltage between 4WD shift switch harness connector terminal 1 and ground.

Connector	Terminal (Wire color)	Voltage (Approx.)
M141	1 (Y/R) - Ground	Battery voltage

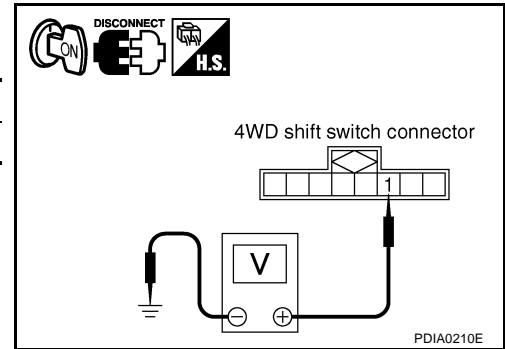

4. Turn ignition switch "OFF".
5. Check voltage between 4WD shift switch harness connector terminal 1 and ground.

Connector	Terminal (Wire color)	Voltage (Approx.)
M141	1 (Y/R) - Ground	0V

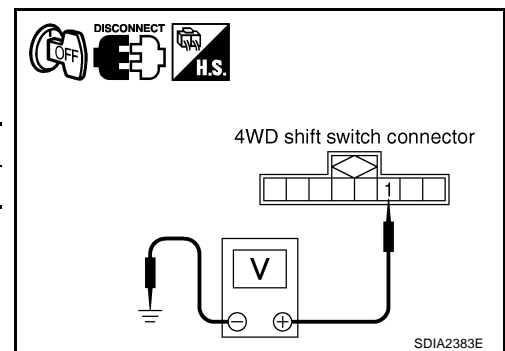

OK or NG

OK >> GO TO 3.

NG >> Check the following. If any items are damaged, repair or replace damaged parts.

- 10A fuses [No. 26 located in the fuse and fusible link box or 59 located in the fuse and relay box]
- Harness for short or open between battery and 4WD shift switch harness connector M141 terminal 1 (Y/R)
- Harness for short or open between ignition switch and transfer relay 1 harness connector E46 terminal 2 (L/W)
- Harness for short or open between transfer relay 1 harness connector E46 terminal 1 (B) and ground.
- Battery and ignition switch. Refer to [PG-4, "POWER SUPPLY ROUTING CIRCUIT"](#).
- Transfer relay 1. Refer to [TF-40, "COMPONENT INSPECTION"](#).

3. CHECK HARNESS BETWEEN 4WD SHIFT SWITCH AND TRANSFER CONTROL UNIT

1. Turn ignition switch "OFF".
2. Disconnect transfer control unit harness connector and the 4WD shift switch harness connector.
3. Check continuity between the following terminals.
 - Transfer control unit harness connector E142 terminal 14 (G/W) and 4WD shift switch harness connector M141 terminal 3 (G/W).
 - Transfer control unit harness connector E142 terminal 15 (O) and 4WD shift switch harness connector M141 terminal 5 (O).
 - Transfer control unit harness connector E142 terminal 16 (R) and 4WD shift switch harness connector M141 terminal 6 (R).

Continuity should exist.

Also check harness for short to ground and short to power.

OK or NG

OK >> GO TO 4.

NG >> Repair or replace damaged parts.

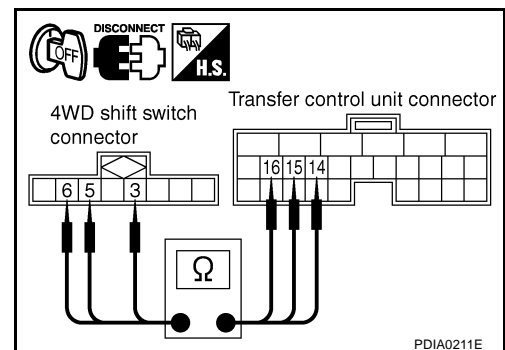

TROUBLE DIAGNOSIS FOR SYSTEM

4. CHECK 4WD SHIFT SWITCH

1. Turn ignition switch "OFF".
2. Disconnect 4WD shift switch harness connector.
3. Operate 4WD shift switch and check continuity between 4WD shift switch terminals.

Terminal	Condition	Continuity
1 - 3	4WD shift switch: 2WD	Yes
	4WD shift switch: 4H and 4LO	No
1 - 5	4WD shift switch: 4H	Yes
	4WD shift switch: 2WD and 4LO	No
1 - 6	4WD shift switch: 4LO	Yes
	4WD shift switch: 2WD and 4H	No

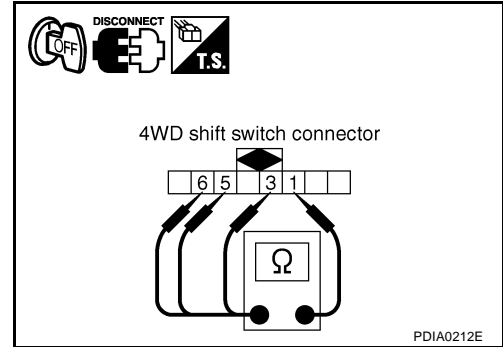

OK or NG

- OK >> GO TO 5.
- NG >> Replace 4WD shift switch.

5. CHECK TRANSFER CONTROL UNIT

Check transfer control unit input/output signal. Refer to [TF-27, "Transfer Control Unit Input/Output Signal Reference Values"](#) .

OK or NG

- OK >> GO TO 6.
- NG >> Check transfer control unit pin terminals for damage or loose connection with harness connector. If any items are damaged, repair or replace damaged parts.

6. CHECK DTC

Perform the self-diagnosis, after driving a vehicle for a while.

OK or NG

- OK >> Inspection End.
- NG >> Replace transfer control unit. Refer to [TF-79, "Removal and Installation"](#) .

COMPONENT INSPECTION

1. Turn ignition switch "OFF".
2. Disconnect 4WD shift switch harness connector.
3. Operate 4WD shift switch and check continuity between 4WD shift switch terminals.

Terminal	Condition	Continuity
1 - 3	4WD shift switch: 2WD	Yes
	4WD shift switch: 4H and 4LO	No
1 - 5	4WD shift switch: 4H	Yes
	4WD shift switch: 2WD and 4LO	No
1 - 6	4WD shift switch: 4LO	Yes
	4WD shift switch: 2WD and 4H	No

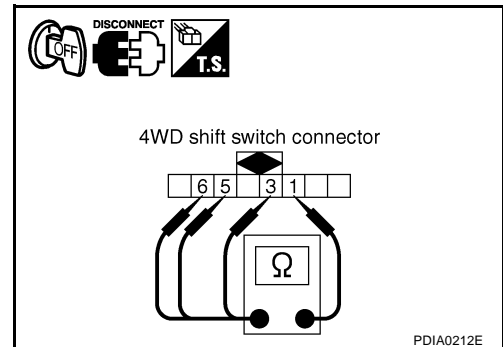

4. If NG, replace the 4WD shift switch.

TROUBLE DIAGNOSIS FOR SYSTEM

Wait Detection Switch

EDS001N9

CONSULT-II REFERENCE VALUE IN DATA MONITOR MODE

Data are reference value.

Monitored item	Content	Condition		Display value
WAIT DETCT SW [ON/OFF]	Condition of wait detection switch	<ul style="list-style-type: none"> ● Vehicle stopped ● Engine running ● A/T selector lever "N" position ● Brake pedal depressed 	4WD shift switch : 4H and 4LO	ON
			4WD shift switch: 2WD	OFF

TRANSFER CONTROL UNIT TERMINALS AND REFERENCE VALUE

Data are reference value and are measured between each terminal and ground.

Terminal	Wire color	Item	Condition	Data (Approx.)
17	G/Y	Wait detection switch	<ul style="list-style-type: none"> ● Vehicle stopped ● Engine running 4WD shift switch: 4H and 4LO	0V
			<ul style="list-style-type: none"> ● A/T selector lever "N" position ● Brake pedal depressed 4WD shift switch: 2WD	Battery voltage

CAUTION:

When using a circuit tester to measure voltage for inspection, be sure not to extend forcibly any connector terminals.

A
B
C
TF
E
F
G
H
I
J
K
L
M

TROUBLE DIAGNOSIS FOR SYSTEM

DIAGNOSTIC PROCEDURE

1. CHECK WAIT DETECTION SWITCH SIGNAL

Ⓟ With CONSULT-II

1. Start engine.
2. Select "DATA MONITOR" mode for "ALL MODE AWD/4WD" with CONSULT-II.
3. Read out the value of "WAIT DETCT SWITCH".

Condition		Display value
<ul style="list-style-type: none"> ● Vehicle stopped ● Engine running 	4WD shift switch: 4H and 4LO	ON
<ul style="list-style-type: none"> ● A/T selector lever "N" position ● Brake pedal depressed 	4WD shift switch: 2WD	OFF

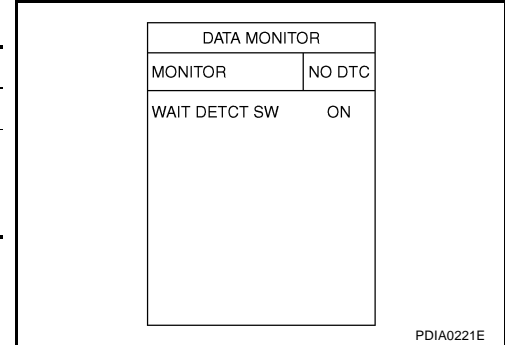

ⓧ Without CONSULT-II

1. Start engine.
2. Check voltage between transfer control unit harness connector terminal and ground.

Connector	Terminal (Wire color)	Condition	Voltage (Approx.)	
E142	17 (G/Y) - Ground	<ul style="list-style-type: none"> ● Vehicle stopped ● Engine running 	4WD shift switch : 4H and 4LO	0V
		<ul style="list-style-type: none"> ● A/T selector lever "N" position ● Brake pedal depressed 	4WD shift switch: 2WD	Battery voltage

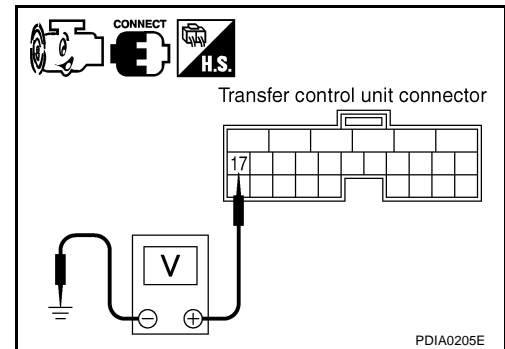

OK or NG

- OK >> GO TO 5.
- NG >> GO TO 2.

2. CHECK HARNESS BETWEEN TRANSFER CONTROL UNIT AND WAIT DETECTION SWITCH

1. Turn ignition switch "OFF".
2. Disconnect transfer control unit harness connector and the wait detection switch harness connector.
3. Check continuity between transfer control unit harness connector E142 terminal 17 (G/Y) and wait detection switch harness connector F59 terminal 10 (G/Y).

Continuity should exist.

Also check harness for short to ground and short to power.

OK or NG

- OK >> GO TO 3.
- NG >> Repair or replace damaged parts.

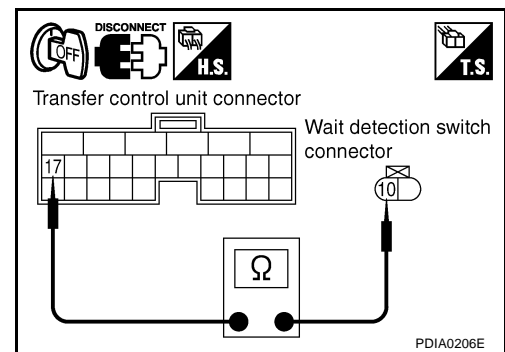

TROUBLE DIAGNOSIS FOR SYSTEM

3. CHECK GROUND CIRCUIT

1. Turn ignition switch "OFF".
2. Disconnect wait detection switch harness connector.
3. Check continuity between wait detection switch harness connector F59 terminal 11 (B) and ground.

Continuity should exist.

Also check harness for short to power.

OK or NG

OK >> GO TO 4.

NG >> Repair open circuit or short to power in harness or connectors.

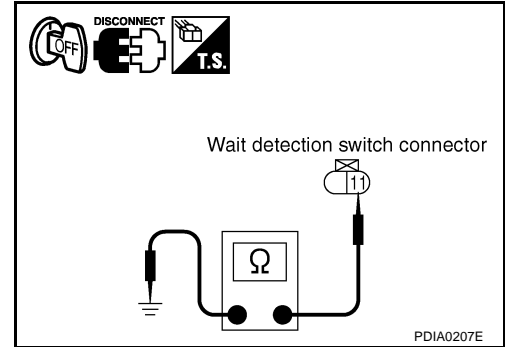

4. CHECK WAIT DETECTION SWITCH

1. Turn ignition switch "OFF".
2. Disconnect wait detection switch harness connector.
3. Remove wait detection switch.
4. Push and release wait detection switch and check continuity between wait detection switch terminals 10 and 11.

Terminal	Condition	Continuity
10 - 11	Push wait detection switch	Yes
	Release wait detection switch	No

OK or NG

OK >> GO TO 5.

NG >> Replace wait detection switch. Refer to [TF-21, "Location of Electrical Parts"](#).

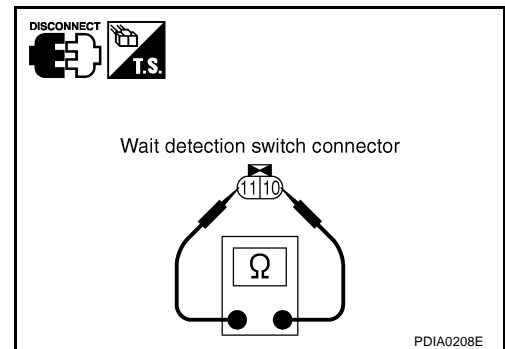

5. CHECK TRANSFER CONTROL UNIT

Check transfer control unit input/output signal. Refer to [TF-27, "Transfer Control Unit Input/Output Signal Reference Values"](#).

OK or NG

OK >> GO TO 6.

NG >> Check transfer control unit pin terminals for damage or loose connection with harness connector. If any items are damaged, repair or replace damaged parts.

6. CHECK DTC

Perform the self-diagnosis, after driving a vehicle for a while.

OK or NG

OK >> Inspection End.

NG >> Replace transfer control unit. Refer to [TF-79, "Removal and Installation"](#).

COMPONENT INSPECTION

1. Turn ignition switch "OFF".
2. Disconnect wait detection switch harness connector.
3. Remove wait detection switch. Refer to [TF-21, "Location of Electrical Parts"](#).

TROUBLE DIAGNOSIS FOR SYSTEM

4. Push and release wait detection switch and check continuity between wait detection switch terminals 10 and 11.

Terminal	Condition	Continuity
10 - 11	Push wait detection switch	Yes
	Release wait detection switch	No

5. If NG, replace the wait detection switch. Refer to [TF-21, "Location of Electrical Parts"](#) .

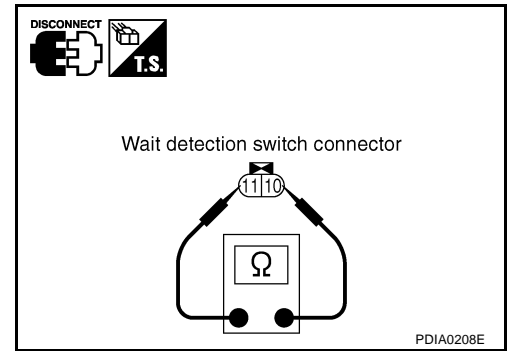

EDS001NA

PNP Switch Signal (TCM) DIAGNOSTIC PROCEDURE

1. CHECK DTC WITH TCM

Perform self-diagnosis with TCM. Refer to [AT-88, "CONSULT-II SETTING PROCEDURE"](#) .

Is any malfunction detected by self-diagnosis?

- YES >> Check the malfunctioning system.
NO >> GO TO 2.

2. CHECK TRANSFER CONTROL UNIT

Check transfer control unit input/output signal. Refer to [TF-27, "Transfer Control Unit Input/Output Signal Reference Values"](#) .

OK or NG

- OK >> GO TO 3.
NG >> Check transfer control unit pin terminals for damage or loose connection with harness connector.
If any items are damaged, repair or replace damaged parts.

3. CHECK DTC

Perform the self-diagnosis, after driving a vehicle for a while.

OK or NG

- OK >> Inspection End.
NG >> Perform self-diagnosis with TCM again. Refer to [AT-88, "CONSULT-II SETTING PROCEDURE"](#) .

TROUBLE DIAGNOSIS FOR SYSTEM

Actuator Motor

EDS001NB

CONSULT-II REFERENCE VALUE IN DATA MONITOR MODE

Data are reference value.

Monitored item	Content	Condition	Display value
SHIFT ACT 1 [ON/OFF]	Output condition to actuator motor (clockwise)	<ul style="list-style-type: none"> ● Vehicle stopped ● Engine running ● A/T selector lever "N" position ● Brake pedal depressed 	4WD shift switch : 4H to 4LO ON
			Except the above OFF
SHIFT AC MON1 [ON/OFF]	Check signal (reinput signal) for transfer control unit signal output	<ul style="list-style-type: none"> ● Vehicle stopped ● Engine running ● A/T selector lever "N" position ● Brake pedal depressed 	4WD shift switch : 4H to 4LO ON
			Except the above OFF
SHIFT ACT 2 [ON/OFF]	Output condition to actuator motor (counterclockwise)	<ul style="list-style-type: none"> ● Vehicle stopped ● Engine running ● A/T selector lever "N" position ● Brake pedal depressed 	4WD shift switch : 4LO to 4H ON
			Except the above OFF
SHIFT AC MON2 [ON/OFF]	Check signal (reinput signal) for transfer control unit signal output	<ul style="list-style-type: none"> ● Vehicle stopped ● Engine running ● A/T selector lever "N" position ● Brake pedal depressed 	4WD shift switch : 4LO to 4H ON
			Except the above OFF

TRANSFER CONTROL UNIT TERMINALS AND REFERENCE VALUE

Data are reference value and are measured between each terminal and ground.

Terminal	Wire color	Item	Condition	Data (Approx.)
27	Y/R	Actuator motor power supply	Ignition switch: ON	Battery voltage
			Ignition switch: OFF	0V
28	Y/L	Actuator motor (+)	4WD shift switch: 2WD to 4H or 4H to 4LO or 2WD to 4LO	Battery voltage
			Except the above	0V
31	G/B	Actuator motor (-)	4WD shift switch: 4LO to 4H or 4H to 2WD or 4LO to 2WD	Battery voltage
			Except the above	0V

CAUTION:

When using a circuit tester to measure voltage for inspection, be sure not to extend forcibly any connector terminals.

TROUBLE DIAGNOSIS FOR SYSTEM

DIAGNOSTIC PROCEDURE

1. CHECK ACTUATOR MOTOR SIGNAL

Ⓟ With CONSULT-II

1. Start engine.
2. Select "DATA MONITOR" mode for "ALL MODE AWD/4WD" with CONSULT-II.
3. Read out the value of "SHIFT ACT 1", "SHIFT ACT MON 1", "SHIFT ACT 2", "SHIFT ACT MON 2".

Monitored item	Condition	Display value
SHIFT ACT 1	4WD shift switch : 4H to 4LO	ON
	Except the above	OFF
SHIFT AC MON1	4WD shift switch : 4H to 4LO	ON
	Except the above	OFF
SHIFT ACT 2	4WD shift switch : 4LO to 4H	ON
	Except the above	OFF
SHIFT AC MON2	4WD shift switch : 4LO to 4H	ON
	Except the above	OFF

DATA MONITOR	
MONITOR	NO DTC
SHIFT ACT1	OFF
SHIFT AC MON1	OFF
SHIFT ACT2	OFF
SHIFT AC MON2	OFF

PDIA0223E

ⓧ Without CONSULT-II

1. Start engine.
2. Check voltage between transfer control unit harness connector terminal and ground.

Connector	Terminal (Wire color)	Condition	Voltage (Approx.)
E143	28 (Y/L) - Ground	4WD shift switch: 2WD to 4H or 4H to 4LO or 2WD to 4LO	Battery voltage
		Except the above	0V
	31 (G/B) - Ground	4WD shift switch: 4LO to 4H or 4H to 2WD or 4LO to 2WD	Battery voltage
		Except the above	0V

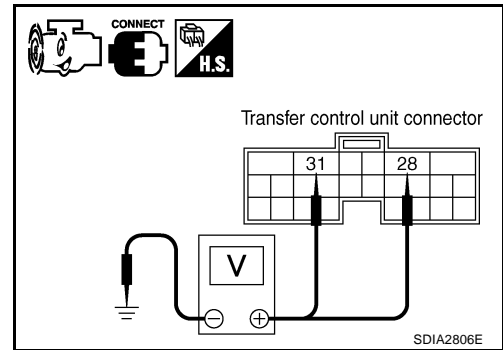

OK or NG

- OK >> GO TO 5.
 NG >> GO TO 2.

TROUBLE DIAGNOSIS FOR SYSTEM

2. CHECK ACTUATOR MOTOR POWER SUPPLY CIRCUIT

1. Turn ignition switch "ON". (Do not start engine.)
2. Disconnect transfer control unit harness connector.
3. Check voltage between transfer control unit harness connector terminal 27 and ground.

Connector	Terminal (Wire color)	Voltage (Approx.)
E143	27 (Y/R) - Ground	Battery voltage

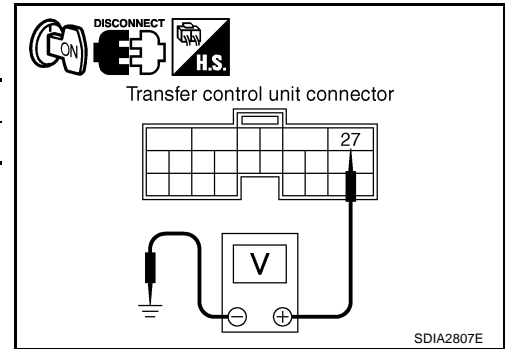

4. Turn ignition switch "OFF".
5. Check voltage between transfer control unit harness connector terminal 27 and ground.

Connector	Terminal (Wire color)	Voltage (Approx.)
E143	27 (Y/R) - Ground	0V

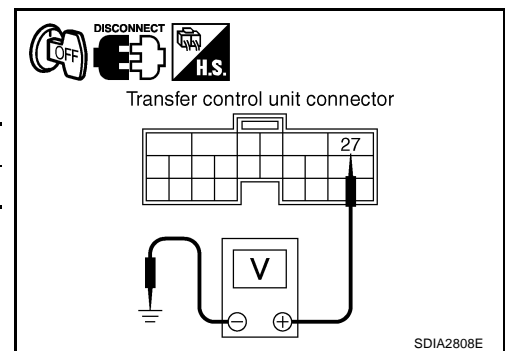

OK or NG

OK >> GO TO 3.

NG >> Check the following. If any items are damaged, repair or replace damaged parts.

- 10A fuses [No. 26 located in the fuse and fusible link box or 59 located in the fuse and relay box]
- Harness for short or open between battery and transfer control unit harness connector E143 terminal 27 (Y/R)
- Harness for short or open between ignition switch and transfer relay 1 harness connector E46 terminal 2 (L/W)
- Harness for short or open between transfer relay 1 harness connector E46 terminal 1 (B) and ground.
- Battery and ignition switch. Refer to [PG-4, "POWER SUPPLY ROUTING CIRCUIT"](#) .
- Transfer relay 1. Refer to [TF-40, "COMPONENT INSPECTION"](#) .

3. CHECK HARNESS BETWEEN TRANSFER CONTROL UNIT AND ACTUATOR MOTOR

1. Turn ignition switch "OFF".
2. Disconnect transfer control unit harness connector and the transfer control device (actuator motor) harness connector.
3. Check continuity between the following terminals.
 - Transfer control unit harness connector E143 terminal 28 (Y/L) and transfer control device (actuator motor) harness connector F58 terminal 24 (Y/L).
 - Transfer control unit harness connector E143 terminal 31 (G/B) and transfer control device (actuator motor) harness connector F58 terminal 23 (G/B).

Continuity should exist.

Also check harness for short to ground and short to power.

OK or NG

OK >> GO TO 4.

NG >> Repair or replace damaged parts.

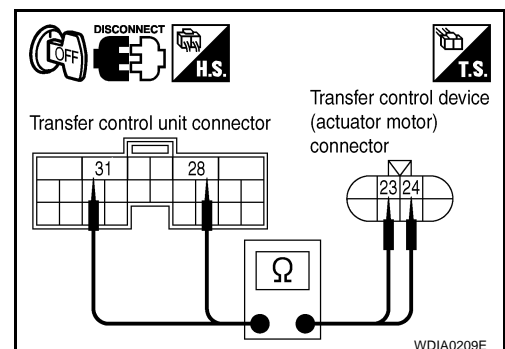

TROUBLE DIAGNOSIS FOR SYSTEM

4. CHECK ACTUATOR MOTOR

1. Remove transfer control device. Refer to [TF-84, "Removal and Installation"](#) .
2. Check operation by applying battery voltage to transfer control device (actuator motor) terminals 23 and 24.

CAUTION:

Be careful not to overheat the harness.

Terminal	Actuator motor
24 (Battery voltage) - 23 (Ground)	Clockwise rotate
23 (Battery voltage) - 24 (Ground)	Counterclockwise rotate

Does actuator motor rotate?

YES >> GO TO 5.

NO >> Replace transfer control device (actuator motor). Refer to [TF-84, "Removal and Installation"](#) .

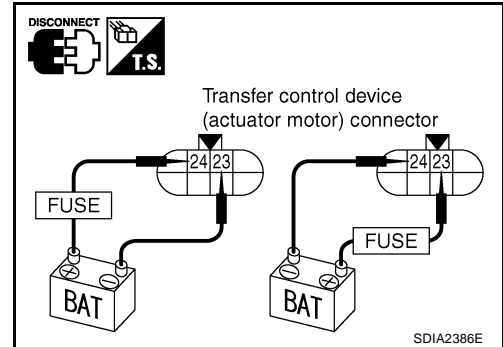

5. CHECK TRANSFER CONTROL UNIT

Check transfer control unit input/output signal. Refer to [TF-27, "Transfer Control Unit Input/Output Signal Reference Values"](#) .

OK or NG

OK >> GO TO 6.

NG >> Check transfer control unit pin terminals for damage or loose connection with harness connector. If any items are damaged, repair or replace damaged parts.

6. CHECK DTC

Perform the self-diagnosis, after driving a vehicle for a while.

OK or NG

OK >> Inspection End.

NG >> Replace transfer control unit. Refer to [TF-79, "Removal and Installation"](#) .

COMPONENT INSPECTION

1. Remove transfer control device. Refer to [TF-84, "Removal and Installation"](#) .
2. Check operation by applying battery voltage to transfer control device (actuator motor) terminals 23 and 24.

CAUTION:

Be careful not to overheat the harness.

Terminal	Actuator motor
24 (Battery voltage) - 23 (Ground)	Clockwise rotate
23 (Battery voltage) - 24 (Ground)	Counterclockwise rotate

3. If NG, replace transfer control device (actuator motor). Refer to [TF-84, "Removal and Installation"](#) .

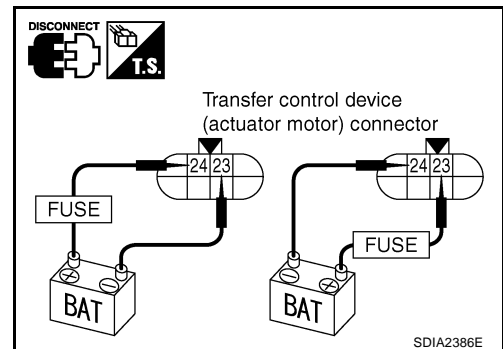

TROUBLE DIAGNOSIS FOR SYSTEM

Actuator Position Switch

EDS001NC

CONSULT-II REFERENCE VALUE IN DATA MONITOR MODE

Data are reference value.

Monitored item [Unit]	Content	Condition	Display value
SHIFT POS SW1 [ON/OFF]	Condition of actuator position switch 1	4WD shift switch: 2WD and 4LO	ON
		4WD shift switch: 4H	OFF
SHIFT POS SW2 [ON/OFF]	Condition of actuator position switch 2	4WD shift switch: 4LO	ON
		4WD shift switch: 2WD and 4H	OFF
SHIFT POS SW3 [ON/OFF]	Condition of actuator position switch 3	4WD shift switch: 2WD and 4H	ON
		4WD shift switch: 4LO	OFF
SHIFT POS SW4 [ON/OFF]	Condition of actuator position switch 4	4WD shift switch: 4H and 4LO	ON
		4WD shift switch: 2WD	OFF

TRANSFER CONTROL UNIT TERMINALS AND REFERENCE VALUE

Data are reference value and are measured between each terminal and ground.

Terminal	Wire color	Item	Condition	Data (Approx.)
10	LG/B	Actuator position switch 1	4WD shift switch: 2WD and 4LO	0V
			4WD shift switch: 4H	Battery voltage
11	W/L	Actuator position switch 2	4WD shift switch: 4LO	0V
			4WD shift switch: 2WD and 4H	Battery voltage
12	BR	Actuator position switch 3	4WD shift switch: 2WD and 4H	0V
			4WD shift switch: 4LO	Battery voltage
13	BR/W	Actuator position switch 4	4WD shift switch: 4H and 4LO	0V
			4WD shift switch: 2WD	Battery voltage

CAUTION:

When using a circuit tester to measure voltage for inspection, be sure not to extend forcibly any connector terminals.

TROUBLE DIAGNOSIS FOR SYSTEM

DIAGNOSTIC PROCEDURE

1. CHECK ACTUATOR POSITION SWITCH SIGNAL

Ⓟ With CONSULT-II

1. Start engine.
2. Select "DATA MONITOR" mode for "ALL MODE AWD/4WD" with CONSULT-II.
3. Read out the value of "SHIFT POS SW1", "SHIFT POS SW2", "SHIFT POS SW3", "SHIFT POS SW4".

Monitored item	Condition	Display value
SHIFT POS SW1	4WD shift switch: 2WD and 4LO	ON
	4WD shift switch: 4H	OFF
SHIFT POS SW2	4WD shift switch: 4LO	ON
	4WD shift switch: 2WD and 4H	OFF
SHIFT POS SW3	4WD shift switch: 2WD and 4H	ON
	4WD shift switch: 4LO	OFF
SHIFT POS SW4	4WD shift switch: 4H and 4LO	ON
	4WD shift switch: 2WD	OFF

DATA MONITOR	
MONITOR	NO DTC
SHIFT POS SW1	ON
SHIFT POS SW2	OFF
SHIFT POS SW3	OFF
SHIFT POS SW4	OFF

PDIA0224E

ⓧ Without CONSULT-II

1. Start engine.
2. Check voltage between transfer control unit harness connector terminal and ground.

Connector	Terminal (Wire color)	Condition	Voltage (Approx.)
E142	10 (LG/B) - Ground	4WD shift switch: 2WD and 4LO	0V
		4WD shift switch: 4H	Battery voltage
	11 (W/L) - Ground	4WD shift switch: 4LO	0V
		4WD shift switch: 2WD and 4H	Battery voltage
	12 (BR) - Ground	4WD shift switch: 2WD and 4H	0V
		4WD shift switch: 4LO	Battery voltage
	13 (BR/W) - Ground	4WD shift switch: 4H and 4LO	0V
		4WD shift switch: 2WD	Battery voltage

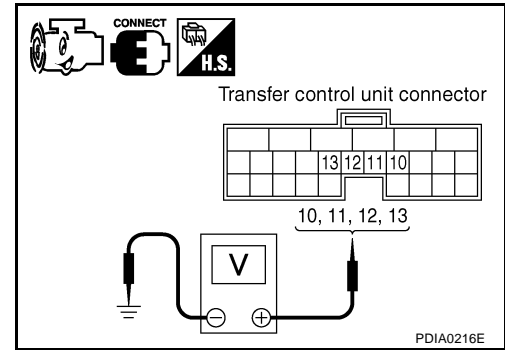

OK or NG

- OK >> GO TO 4.
 NG >> GO TO 2.

TROUBLE DIAGNOSIS FOR SYSTEM

2. CHECK HARNESS BETWEEN TRANSFER CONTROL UNIT AND ACTUATOR POSITION SWITCH

1. Turn ignition switch "OFF".
2. Disconnect transfer control unit harness connector and the transfer control device (actuator position switch) harness connector.
3. Check continuity between the following terminals.
 - Transfer control unit harness connector E142 terminal 10 (LG/B) and transfer control device (actuator position switch) harness connector F58 terminal 26 (LG/B).
 - Transfer control unit harness connector E142 terminal 11 (W/L) and transfer control device (actuator position switch) harness connector F58 terminal 20 (W/L).
 - Transfer control unit harness connector E142 terminal 12 (BR) and transfer control device (actuator position switch) harness connector F58 terminal 21 (BR).
 - Transfer control unit harness connector E142 terminal 13 (BR/W) and transfer control device (actuator position switch) harness connector F58 terminal 25 (BR/W).

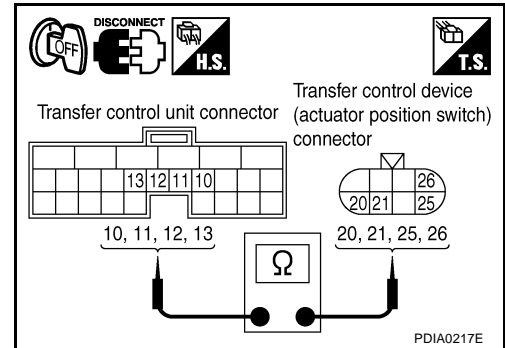

Continuity should exist.

Also check harness for short to ground and short to power.

OK or NG

- OK >> GO TO 3.
- NG >> Repair or replace damaged parts.

3. CHECK GROUND CIRCUIT

1. Turn ignition switch "OFF".
2. Disconnect transfer control device (actuator position switch) harness connector.
3. Check continuity between transfer control device (actuator position switch) harness connector F58 terminal 22 (B) and ground.

Continuity should exist.

Also check harness for short to power.

OK or NG

- OK >> GO TO 4.
- NG >> Repair open circuit or short to power in harness or connectors.

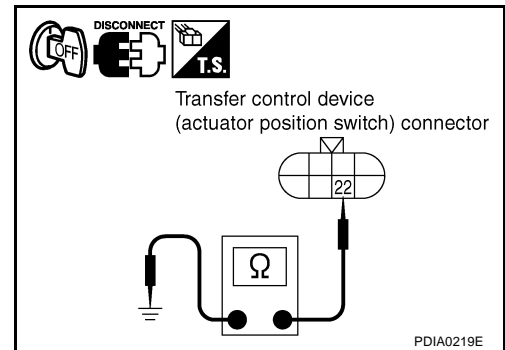

4. CHECK TRANSFER CONTROL UNIT

Check transfer control unit input/output signal. Refer to [TF-27, "Transfer Control Unit Input/Output Signal Reference Values"](#).

OK or NG

- OK >> GO TO 5.
- NG >> Check transfer control unit pin terminals for damage or loose connection with harness connector. If any items are damaged, repair or replace damaged parts.

5. CHECK DTC

Perform the self-diagnosis, after driving a vehicle for a while.

OK or NG

- OK >> Inspection End.
- NG >> Replace transfer control device. Refer to [TF-84, "Removal and Installation"](#).

TROUBLE DIAGNOSIS FOR SYSTEM

Transfer Control Device

EDS001ND

CONSULT-II REFERENCE VALUE IN DATA MONITOR MODE

Data are reference value.

Monitored item [Unit]	Content	Condition		Display value
SHIFT ACT/R MON [ON/OFF]	Operating condition of actuator motor relay (integrated in transfer control unit)	<ul style="list-style-type: none"> ● Vehicle stopped ● Engine running ● A/T selector lever "N" position ● Brake pedal depressed 	When 4WD shift switch is operated	ON
			When 4WD shift switch is not operated	OFF

TRANSFER CONTROL UNIT TERMINALS AND REFERENCE VALUE

Data are reference value and are measured between each terminal and ground.

Terminal	Wire color	Item	Condition	Data (Approx.)
25	L/W	Ignition switch monitor	Ignition switch: ON	Battery voltage
			Ignition switch: OFF	0V
27	Y/R	Actuator motor power supply	Ignition switch: ON	Battery voltage
			Ignition switch: OFF	0V
32	B	Actuator motor ground	Always	0V
40	Y	Transfer relay 2	Ignition switch: ON	0V
			Ignition switch: OFF	Battery voltage

CAUTION:

When using a circuit tester to measure voltage for inspection, be sure not to extend forcibly any connector terminals.

TROUBLE DIAGNOSIS FOR SYSTEM

DIAGNOSTIC PROCEDURE

1. CHECK POWER SUPPLY

1. Turn ignition switch "OFF".
2. Disconnect transfer control unit harness connector.
3. Check voltage between transfer control unit harness connector terminal and ground.

Connector	Terminal (Wire color)	Voltage (Approx.)
E142	25 (L/W) - Ground	0V
E143	27 (Y/R) - Ground	

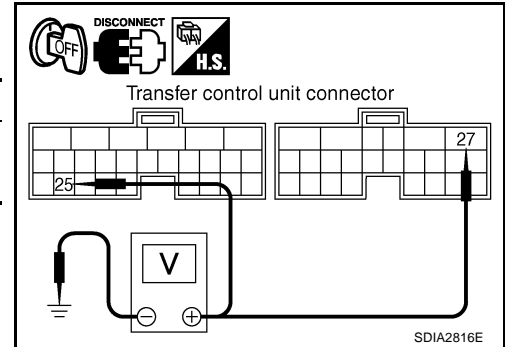

4. Turn ignition switch "ON". (Do not start engine.)
5. Check voltage between transfer control unit harness connector terminals and ground.

Connector	Terminal (Wire color)	Voltage (Approx.)
E142	25 (L/W) - Ground	Battery voltage
E143	27 (Y/R) - Ground	

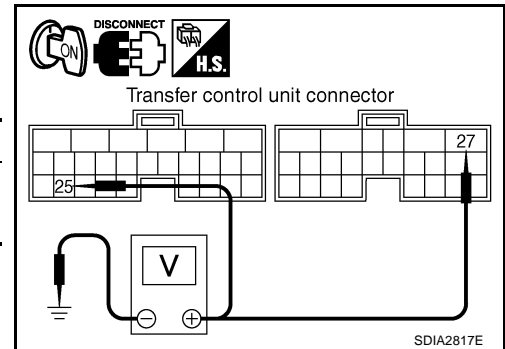

OK or NG

OK >> GO TO 2.

NG >> Check the following. If any items are damaged, repair or replace damaged parts.

- 10A fuses [No. 26 located in the fuse and fusible link box or 59 located in the fuse and relay box]
- Harness for short or open between battery and transfer control unit harness connector E143 terminal 27 (Y/R)
- Harness for short or open between ignition switch and transfer relay 1 harness connector E46 terminal 2 (L/W)
- Harness for short or open between ignition switch and transfer control unit harness connector E142 terminal 25 (L/W)
- Harness for short or open between transfer relay 1 harness connector E46 terminal 1 (B) and ground
- Battery and ignition switch. Refer to [PG-4, "POWER SUPPLY ROUTING CIRCUIT"](#) .
- Transfer relay 1. Refer to [TF-40, "COMPONENT INSPECTION"](#) .

2. CHECK GROUND CIRCUIT

1. Disconnect transfer control unit harness connector.
2. Check continuity between transfer control unit harness connector E143 terminal 32 (B) and ground.

Continuity should exist.

Also check harness for short to power.

OK or NG

OK >> GO TO 3.

NG >> Repair open circuit or short to power in harness or connectors.

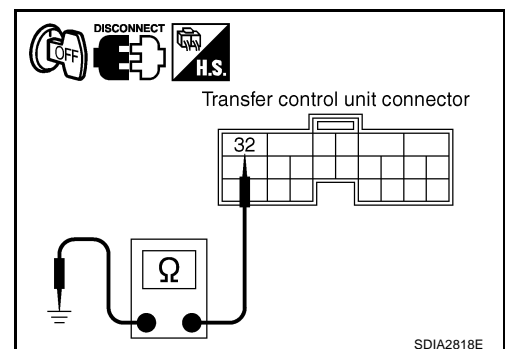

TROUBLE DIAGNOSIS FOR SYSTEM

3. CHECK POWER SUPPLY SIGNAL

1. Turn ignition switch "OFF".
2. Connect transfer control unit harness connector.
3. Check voltage between transfer control unit harness connector terminal and ground.

Connector	Terminal (Wire color)	Voltage (Approx.)
E143	40 (Y) - Ground	Battery voltage

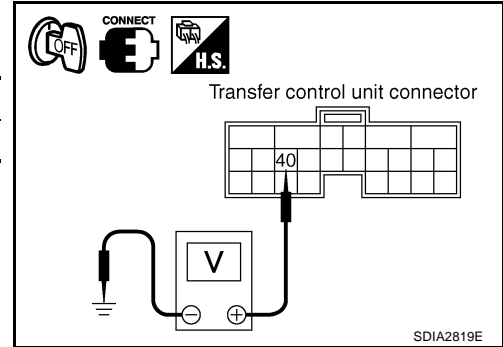

4. Turn ignition switch "ON". (Do not start engine.)
5. Check voltage between transfer control unit harness connector terminal and ground.

Connector	Terminal (Wire color)	Voltage (Approx.)
E143	40 (Y) - Ground	0V

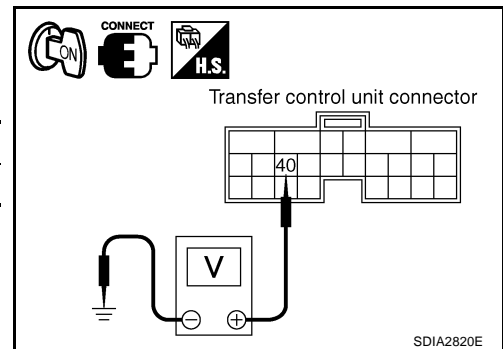

OK or NG

- OK >> GO TO 4.
NG >> Check the following. If any items are damaged, repair or replace damaged parts.
- Harness for short or open between battery and transfer control unit harness connector E143 terminal 40 (Y)
 - Transfer relay 2. Refer to [TF-40, "COMPONENT INSPECTION"](#) .

4. CHECK TRANSFER CONTROL UNIT

Check transfer control unit input/output signal. Refer to [TF-27, "Transfer Control Unit Input/Output Signal Reference Values"](#) .

OK or NG

- OK-1 >> With CONSULT-II: GO TO 5.
OK-2 >> Without CONSULT-II: GO TO 6.
NG >> Check transfer control unit pin terminals for damage or loose connection with harness connector. If any items are damaged, repair or replace damaged parts.

5. PERFORM SELF-DIAGNOSIS (WITH CONSULT-II)

With CONSULT-II

1. Turn ignition switch "ON". (Do not start engine.)
2. Select "SELF-DIAG RESULTS" mode for "ALL MODE AWD/4WD" with CONSULT-II.
3. Touch "ERASE".
4. Turn ignition switch "OFF" and wait at least 10 seconds.
5. Perform the self-diagnosis again.

Is the "SHIFT ACT CIR [P1819]" displayed?

- YES >> Replace transfer control unit. Refer to [TF-79, "Removal and Installation"](#) .
NO >> Inspection End.

TROUBLE DIAGNOSIS FOR SYSTEM

6. PERFORM SELF-DIAGNOSIS (WITHOUT CONSULT-II)

⊗ Without CONSULT-II

1. Perform the self-diagnosis and then erase self-diagnostic results. Refer to [TF-36, "SELF-DIAGNOSTIC PROCEDURE \(WITHOUT CONSULT-II\)"](#) and [TF-37, "ERASE SELF-DIAGNOSIS"](#) .
2. Perform the self-diagnosis again.

Do the self-diagnostic results indicate transfer control device?

- YES >> Replace transfer control unit. Refer to [TF-79, "Removal and Installation"](#) .
NO >> Inspection End.

Engine Speed Signal (ECM) DIAGNOSTIC PROCEDURE

EDS001NE

TF

1. CHECK DTC WITH ECM

Perform self-diagnosis with ECM. Refer to [EC-131, "SELF-DIAG RESULTS MODE"](#) .

Is any malfunction detected by self-diagnosis?

- YES >> Check the malfunctioning system.
NO >> GO TO 2.

2. CHECK TRANSFER CONTROL UNIT

Check transfer control unit input/output signal. Refer to [TF-27, "Transfer Control Unit Input/Output Signal Reference Values"](#) .

OK or NG

- OK >> GO TO 3.
NG >> Check transfer control unit pin terminals for damage or loose connection with harness connector.
If any items are damaged, repair or replace damaged parts.

3. CHECK DTC

Perform the self-diagnosis, after driving a vehicle for a while.

OK or NG

- OK >> Inspection End.
NG >> Perform self-diagnosis with ECM again. Refer to [EC-131, "SELF-DIAG RESULTS MODE"](#) .

TROUBLE DIAGNOSIS FOR SYSTEM

EDS001NF

CAN Communication Line DIAGNOSTIC PROCEDURE

1. CHECK CAN COMMUNICATION CIRCUIT

Ⓟ **With CONSULT-II**

1. Turn ignition switch "ON" and start engine.
2. Select "SELF-DIAG RESULTS" mode for "ALL MODE AWD/4WD" with in CONSULT-II.
3. Perform the self-diagnosis.

Is the "CAN COMM CIRCUIT [U1000]" displayed?

- YES >> Print out CONSULT-II screen and go to [LAN-5, "Precautions When Using CONSULT-II"](#) .
- NO >> Inspection End.

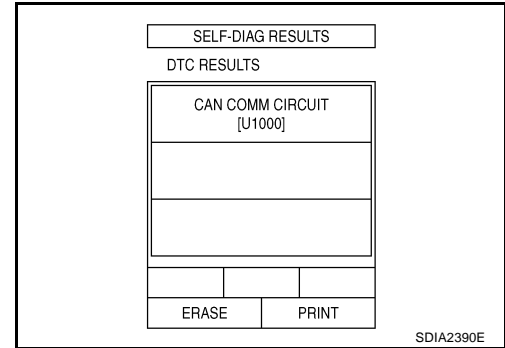

ATP Switch

CONSULT-II REFERENCE VALUE IN DATA MONITOR MODE

EDS001NG

Data are reference value.

Monitored item [Unit]	Content	Condition	Display value
ATP SWITCH [ON/OFF]	Condition of ATP switch	<ul style="list-style-type: none"> ● Vehicle stopped ● Engine running ● A/T selector lever "P" position 	4WD shift switch : 4H to 4LO or 4LO to 4H (While actuator motor is operating.)
		<ul style="list-style-type: none"> ● Brake pedal depressed 	Except the above

TRANSFER CONTROL UNIT TERMINALS AND REFERENCE VALUE

Data are reference value and are measured between each terminal and ground.

Terminal	Wire color	Item	Condition	Data (Approx.)
23	R/B	ATP switch	<ul style="list-style-type: none"> ● Vehicle stopped ● Engine running 	4WD shift switch: 4H to 4LO or 4LO to 4H (While actuator motor is operating.)
			<ul style="list-style-type: none"> ● A/T selector lever "P" position ● Brake pedal depressed 	Except the above

CAUTION:

When using a circuit tester to measure voltage for inspection, be sure not to extend forcibly any connector terminals.

TROUBLE DIAGNOSIS FOR SYSTEM

DIAGNOSTIC PROCEDURE

1. CHECK ATP SWITCH SIGNAL

With CONSULT-II

1. Start engine.
2. Select "DATA MONITOR" mode for "ALL MODE AWD/4WD" with CONSULT-II.
3. Read out the value of "ATP SWITCH".

	Condition	Display value
<ul style="list-style-type: none"> ● Vehicle stopped ● Engine running 	4WD shift switch: 4H to 4LO or 4LO to 4H (While actuator motor is operating.)	ON
<ul style="list-style-type: none"> ● A/T selector lever "P" position ● Brake pedal depressed 	Except the above	OFF

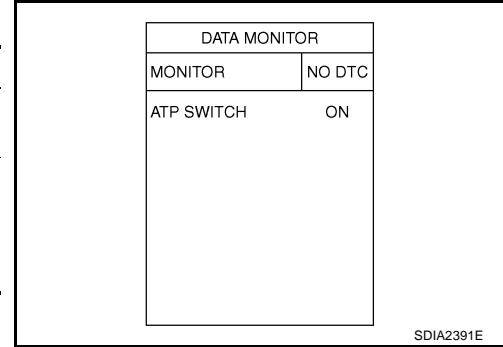

Without CONSULT-II

1. Start engine.
2. Check voltage between transfer control unit harness connector terminal and ground.

Connector	Terminal (Wire color)	Condition	Voltage (Approx.)
E142	23 (R/B) - Ground	<ul style="list-style-type: none"> ● Vehicle stopped ● Engine running 	4WD shift switch: 4H to 4LO or 4LO to 4H (While actuator motor is operating.)
		<ul style="list-style-type: none"> ● A/T selector lever "P" position ● Brake pedal depressed 	Except the above
			0V
			Battery voltage

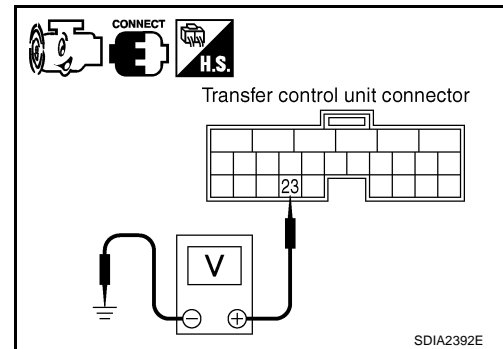

OK or NG

- OK >> GO TO 5.
- NG >> GO TO 2.

2. CHECK HARNESS BETWEEN TRANSFER CONTROL UNIT AND ATP SWITCH

1. Turn ignition switch "OFF".
2. Disconnect transfer control unit harness connector and the ATP switch connector.
3. Check continuity between transfer control unit harness connector E142 terminal 23 (R/B) and ATP switch harness connector F55 terminal 8 (R/B).

Continuity should exist.

Also check harness for short to ground and short to power.

OK or NG

- OK >> GO TO 3.
- NG >> Repair or replace damaged parts.

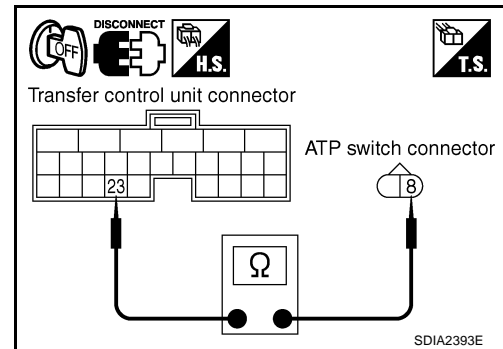

TROUBLE DIAGNOSIS FOR SYSTEM

3. CHECK GROUND CIRCUIT

1. Turn ignition switch "OFF".
2. Disconnect ATP switch harness connector.
3. Check continuity between ATP switch harness connector F55 terminal 9 (B) and ground.

Continuity should exist.

Also check harness for short to power.

OK or NG

OK >> GO TO 4.

NG >> Repair open circuit or short to power in harness or connectors.

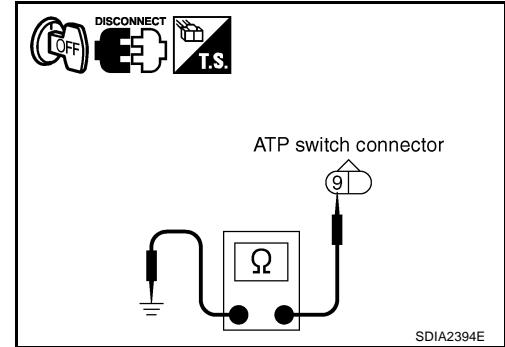

4. CHECK ATP SWITCH

1. Turn ignition switch "OFF".
2. Disconnect ATP switch harness connector.
3. Remove ATP switch. Refer to [TF-21, "Location of Electrical Parts"](#).
4. Push and release ATP switch and check continuity between ATP switch terminals 8 and 9.

Terminal	Condition	Continuity
8 - 9	Push ATP switch	Yes
	Release ATP switch	No

OK or NG

OK >> GO TO 5.

NG >> Replace ATP switch. Refer to [TF-21, "Location of Electrical Parts"](#).

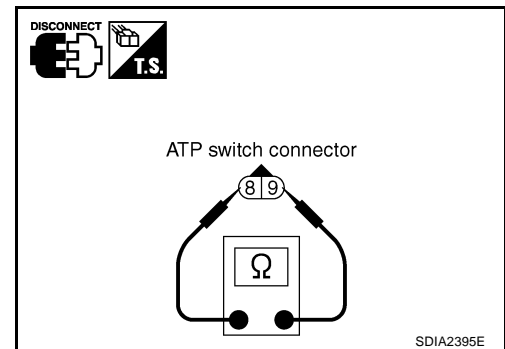

5. CHECK TRANSFER CONTROL UNIT

Check transfer control unit input/output signal. Refer to [TF-27, "Transfer Control Unit Input/Output Signal Reference Values"](#).

OK or NG

OK >> GO TO 6.

NG >> Check transfer control unit pin terminals for damage or loose connection with harness connector. If any items are damaged, repair or replace damaged parts.

6. CHECK ATP WARNING LAMP

1. Turn ignition switch "ON". (Do not start engine.)
2. Set the A/T selector lever to "P" position and engage the parking brake.
3. Switch 4WD shift switch from 4H to 4LO or 4LO to 4H.

Does ATP warning lamp turn "ON", while actuator motor is operating?

YES >> Inspection End.

NO >> Go to [TF-74, "ATP Warning Lamp Does Not Turn ON"](#).

COMPONENT INSPECTION

1. Turn ignition switch "OFF".
2. Disconnect ATP switch harness connector.
3. Remove ATP switch. Refer to [TF-21, "Location of Electrical Parts"](#).

TROUBLE DIAGNOSIS FOR SYSTEM

4. Push and release ATP switch and check continuity between ATP switch terminals 8 and 9.

Terminal	Condition	Continuity
8 - 9	Push ATP switch	Yes
	Release ATP switch	No

5. If NG, replace the ATP switch. Refer to [TF-21, "Location of Electrical Parts"](#) .

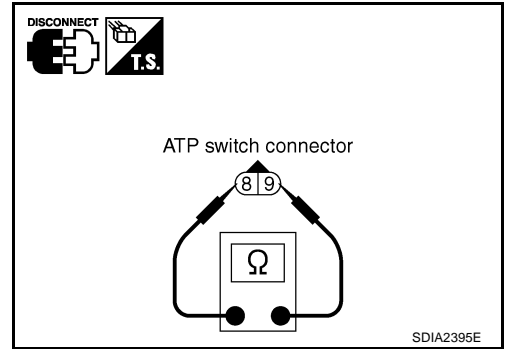

A
B
C
TF
E
F
G
H
I
J
K
L
M

TROUBLE DIAGNOSIS FOR SYMPTOMS

PFP:00007

TROUBLE DIAGNOSIS FOR SYMPTOMS

4WD Shift Indicator Lamp and 4LO Indicator Lamp Do Not Turn ON

ES001NH

SYMPTOM:
4WD shift indicator lamp and 4LO indicator lamp do not turn ON for approx. 1 second when turning ignition switch to "ON".

DIAGNOSTIC PROCEDURE

1. CHECK TRANSFER CONTROL UNIT POWER SUPPLY CIRCUIT

1. Turn ignition switch "OFF".
2. Disconnect transfer control unit harness connector.
3. Check voltage between transfer control unit harness connector terminals and ground.

Connector	Terminal (Wire color)	Voltage (Approx.)
E142	19 (W) - Ground	Battery voltage
	25 (L/W) - Ground	0V
E143	40 (Y) - Ground	Battery voltage
	44 (Y/R) - Ground	0V
	45 (Y/R) - Ground	

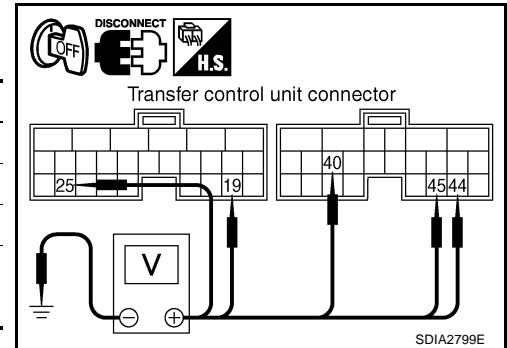

4. Turn ignition switch "ON". (Do not start engine.)
5. Check voltage between transfer control unit harness connector terminals and ground.

Connector	Terminal (Wire color)	Voltage (Approx.)
E142	19 (W) - Ground	Battery voltage
	25 (L/W) - Ground	
E143	40 (Y) - Ground	
	44 (Y/R) - Ground	
	45 (Y/R) - Ground	

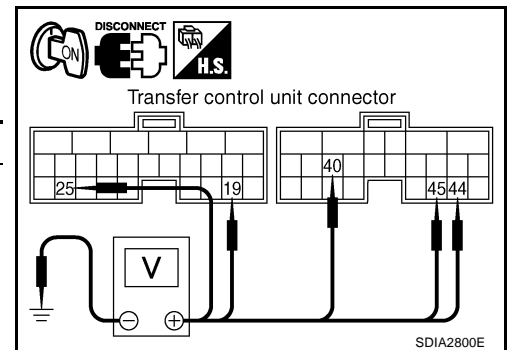

OK or NG

OK >> GO TO 2.

NG >> Check the following. If any items are damaged, repair or replace damaged parts.

- 10A fuses [No. 26 located in the fuse and fusible link box or 59 located in the fuse and relay box]
- 20A fuse [No. 53, located in the IPDM E/R]
- Harness for short or open between battery and transfer control unit harness connector E142 terminal 19 (W), and connector E143 terminals 40 (Y), 44 (Y/R) and 45 (Y/R)
- Harness for short or open between ignition switch and transfer control unit harness connector E142 terminal 25 (L/W)
- Harness for short or open between ignition switch and transfer relay 1 harness connector E46 terminal 2 (L/W)
- Harness for short or open between transfer relay 1 harness connector E46 terminal 1 (B) and ground
- Battery and ignition switch. Refer to [PG-4, "POWER SUPPLY ROUTING CIRCUIT"](#) .
- Transfer relay 1, 2. Refer to [TF-40, "COMPONENT INSPECTION"](#) .

TROUBLE DIAGNOSIS FOR SYMPTOMS

2. CHECK TRANSFER CONTROL UNIT GROUND CIRCUIT

1. Turn ignition switch "OFF".
2. Disconnect transfer control unit harness connector.
3. Check continuity between transfer control unit harness connector E142 terminals 6 (B), 18 (B), E143 terminal 32 (B) and ground.

Continuity should exist.

Also check harness for short to power.

OK or NG

- OK >> GO TO 3.
 NG >> Repair open circuit or short to power in harness or connectors.

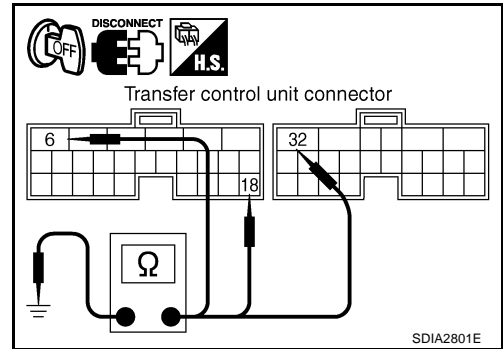

3. CHECK COMBINATION METER POWER SUPPLY CIRCUIT

1. Turn ignition switch "OFF".
2. Disconnect combination meter harness connector.
3. Check voltage between combination meter harness connector terminals and ground.

Connector	Terminal (Wire color)	Voltage (Approx.)
M24	24 (O/L) - Ground	0V

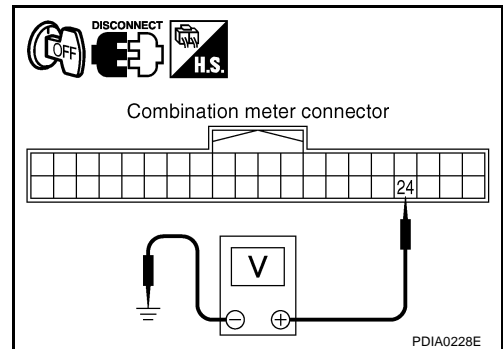

4. Turn ignition switch "ON". (Do not start engine.)
5. Check voltage between combination meter harness connector terminals and ground.

Connector	Terminal (Wire color)	Voltage (Approx.)
M24	24 (O/L) - Ground	Battery voltage

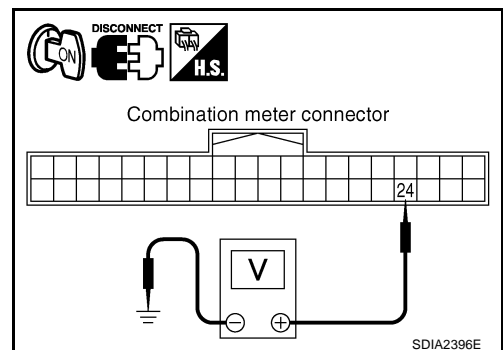

OK or NG

- OK >> GO TO 4.
 NG >> Check the following. If any items are damaged, repair or replace damaged parts.
- 10A fuses [No. 26 located in the fuse and fusible link box or 59 located in the fuse and relay box]
 - Harness for short or open between battery and combination meter harness connector M24 terminal 24 (O/L)
 - Battery and Ignition switch. Refer to [PG-4, "POWER SUPPLY ROUTING CIRCUIT"](#) .
 - Transfer relay 1, 2. Refer to [TF-40, "COMPONENT INSPECTION"](#) .

TROUBLE DIAGNOSIS FOR SYMPTOMS

4. CHECK HARNESS BETWEEN TRANSFER CONTROL UNIT AND COMBINATION METER

1. Turn ignition switch "OFF".
2. Disconnect transfer control unit harness connector and combination meter harness connector.
3. Check continuity between the following terminals.
 - Transfer control unit harness connector E143 terminal 35 (B/W) and combination meter harness connector M24 terminal 32 (B/W)
 - Transfer control unit harness connector E143 terminal 36 (L) and combination meter harness connector M24 terminal 31 (L)
 - Transfer control unit harness connector E143 terminal 37 (W/G) and combination meter harness connector M24 terminal 33 (W/G)

Continuity should exist.

Also check harness for short to ground and short to power.

OK or NG

- OK >> GO TO 5.
- NG >> Repair or replace damaged parts.

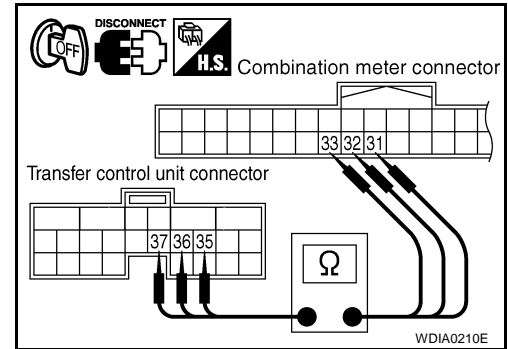

5. CHECK 4WD SHIFT INDICATOR LAMP AND 4LO INDICATOR LAMP CIRCUIT

1. Turn ignition switch "OFF".
2. Check the combination meter. Refer to [DI-5, "COMBINATION METERS"](#).

OK or NG

- OK >> GO TO 6.
- NG >> Replace the combination meter. Refer to [IP-13, "COMBINATION METER"](#).

6. SYMPTOM CHECK

Check again.

OK or NG

- OK >> Inspection End.
- NG >> GO TO 7.

7. CHECK TRANSFER CONTROL UNIT

Check transfer control unit input/output signal. Refer to [TF-27, "Transfer Control Unit Input/Output Signal Reference Values"](#).

OK or NG

- OK >> Inspection End.
- NG >> Check transfer control unit pin terminals for damage or loose connection with harness connector. If any items are damaged, repair or replace damaged parts.

TROUBLE DIAGNOSIS FOR SYMPTOMS

EDS001NI

4WD Warning Lamp Does Not Turn ON

SYMPTOM:

4WD warning lamp do not turn ON when turning ignition switch to "ON".

DIAGNOSTIC PROCEDURE

1. CHECK TRANSFER CONTROL UNIT POWER SUPPLY CIRCUIT

1. Turn ignition switch "OFF".
2. Disconnect transfer control unit harness connector.
3. Check voltage between transfer control unit harness connector terminals and ground.

Connector	Terminal (Wire color)	Voltage (Approx.)
E142	19 (W) - Ground	Battery voltage
	25 (L/W) - Ground	0V
E143	40 (Y) - Ground	Battery voltage
	44 (Y/R) - Ground	0V
	45 (Y/R) - Ground	

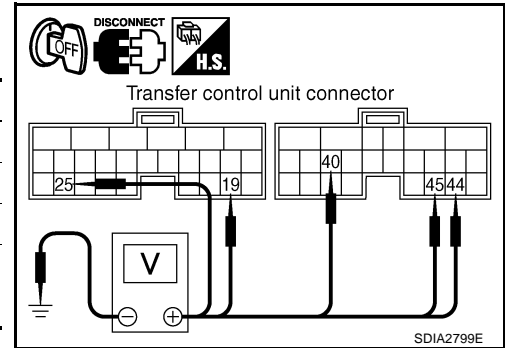

4. Turn ignition switch "ON". (Do not start engine.)
5. Check voltage between transfer control unit harness connector terminals and ground.

Connector	Terminal (Wire color)	Voltage (Approx.)
E142	19 (W) - Ground	Battery voltage
	25 (L/W) - Ground	
E143	40 (Y) - Ground	
	44 (Y/R) - Ground	
	45 (Y/R) - Ground	

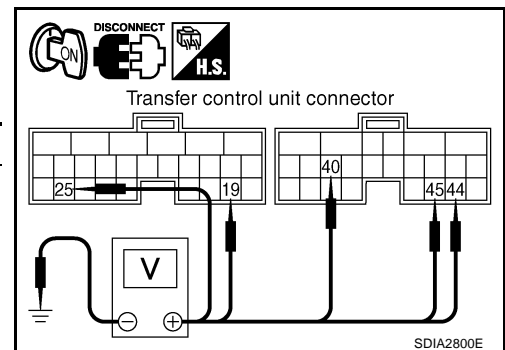

OK or NG

OK >> GO TO 2.

NG >> Check the following. If any items are damaged, repair or replace damaged parts.

- 10A fuses [No. 26 located in the fuse and fusible link box or 59 located in the fuse and relay box]
- 20A fuse [No. 53, located in the IPDM E/R]
- Harness for short or open between battery and transfer control unit harness connector E142 terminal 19 (W), and connector E143 terminals 40 (Y), 44 (Y/R) and 45 (Y/R)
- Harness for short or open between ignition switch and transfer control unit harness connector E142 terminal 25 (L/W)
- Harness for short or open between ignition switch and transfer relay 1 harness connector E46 terminal 2 (L/W)
- Harness for short or open between transfer relay 1 harness connector E46 terminal 1 (B) and ground
- Battery and ignition switch. Refer to [PG-4, "POWER SUPPLY ROUTING CIRCUIT"](#) .
- Transfer relay 1, 2. Refer to [TF-40, "COMPONENT INSPECTION"](#) .

TROUBLE DIAGNOSIS FOR SYMPTOMS

2. CHECK TRANSFER CONTROL UNIT GROUND CIRCUIT

1. Turn ignition switch "OFF".
2. Disconnect transfer control unit harness connector.
3. Check continuity between transfer control unit harness connector E142 terminals 6 (B), 18 (B), E143 terminal 32 (B) and ground.

Continuity should exist.

Also check harness for short to power.

OK or NG

OK >> GO TO 3.

NG >> Repair open circuit or short to power in harness or connectors.

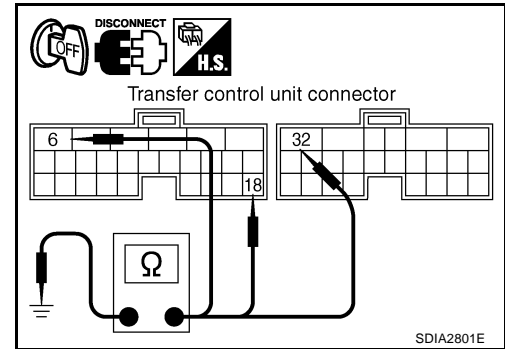

3. CHECK COMBINATION METER POWER SUPPLY CIRCUIT

1. Turn ignition switch "OFF".
2. Disconnect transfer control unit harness connector.
3. Check voltage between combination meter harness connector terminals and ground.

Connector	Terminal (Wire color)	Voltage (Approx.)
M24	24 (O/L) - Ground	0V

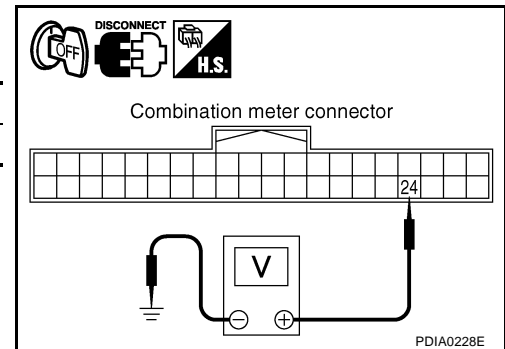

4. Turn ignition switch "ON". (Do not start engine.)
5. Check voltage between combination meter harness connector terminals and ground.

Connector	Terminal (Wire color)	Voltage (Approx.)
M24	24 (O/L) - Ground	Battery voltage

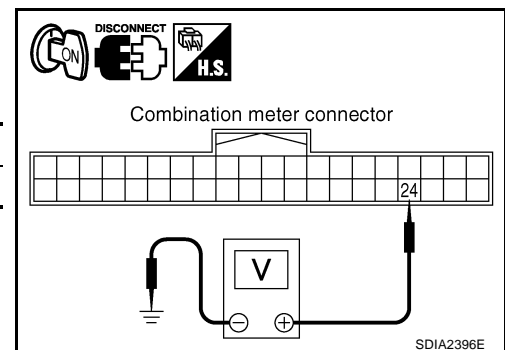

OK or NG

OK >> GO TO 4.

NG >> Check the following. If any items are damaged, repair or replace damaged parts.

- 10A fuses [No. 26 located in the fuse and fusible link box or 59 located in the fuse and relay box]
- Harness for short or open between battery and combination meter harness connector M24 terminal 24 (O/L)
- Battery and Ignition switch. Refer to [PG-4, "POWER SUPPLY ROUTING CIRCUIT"](#) .
- Transfer relay 1, 2. Refer to [TF-40, "COMPONENT INSPECTION"](#) .

TROUBLE DIAGNOSIS FOR SYMPTOMS

4. CHECK HARNESS BETWEEN TRANSFER CONTROL UNIT AND COMBINATION METER

1. Turn ignition switch "OFF".
2. Disconnect transfer control unit harness connector and combination meter harness connector.
3. Check continuity between transfer control unit harness connector E143 terminal 38 (W/B) and combination meter harness connector M24 terminal 34 (W/B).

Continuity should exist.

Also check harness for short to ground and short to power.

OK or NG

- OK >> GO TO 5.
NG >> Repair or replace damaged parts.

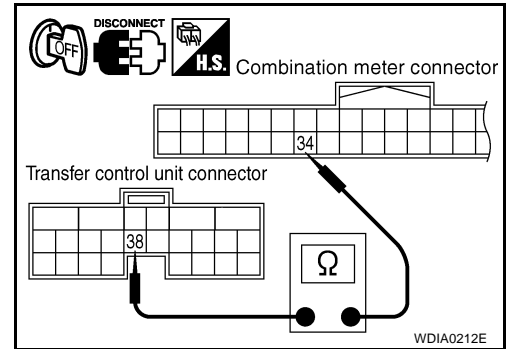

5. CHECK 4WD WARNING LAMP CIRCUIT

1. Turn ignition switch "OFF".
2. Check the combination meter. Refer to [DI-5, "COMBINATION METERS"](#).

OK or NG

- OK >> GO TO 6.
NG >> Replace the combination meter. Refer to [IP-13, "COMBINATION METER"](#).

6. SYMPTOM CHECK

Check again.

OK or NG

- OK >> Inspection End.
NG >> GO TO 7.

7. CHECK TRANSFER CONTROL UNIT

Check transfer control unit input/output signal. Refer to [TF-27, "Transfer Control Unit Input/Output Signal Reference Values"](#).

OK or NG

- OK >> Inspection End.
NG >> Check transfer control unit pin terminals for damage or loose connection with harness connector. If any items are damaged, repair or replace damaged parts.

4WD Shift Indicator Lamp or 4LO Indicator Lamp Do Not Change

EDS001NJ

SYMPTOM:
4WD shift indicator lamp or 4LO indicator lamp do not change when switch 4WD shift switch.

DIAGNOSTIC PROCEDURE

1. CONFIRM THE SYMPTOM

Confirm 4WD shift indicator lamp and 4LO indicator lamp when ignition switch is turned to ON.

Do 4WD shift indicator lamp and 4LO indicator lamp turn on?

- YES >> GO TO 2.
NO >> Go to [TF-68, "4WD Shift Indicator Lamp and 4LO Indicator Lamp Do Not Turn ON"](#).

2. CHECK SYSTEM FOR 4WD SHIFT SWITCH

Perform trouble diagnosis for 4WD shift switch system. Refer to [TF-45, "4WD Shift Switch"](#).

OK or NG

- OK >> GO TO 3.
NG >> Repair or replace damaged parts.

TROUBLE DIAGNOSIS FOR SYMPTOMS

3. CHECK SYSTEM FOR WAIT DETECTION SWITCH

Perform trouble diagnosis for wait detection switch system. Refer to [TF-49, "Wait Detection Switch"](#) .

OK or NG

- OK >> GO TO 4.
- NG >> Repair or replace damaged parts.

4. CHECK SYSTEM FOR 4LO SWITCH

Perform trouble diagnosis for 4LO switch system. Refer to [TF-42, "4LO Switch"](#) .

OK or NG

- OK >> GO TO 5.
- NG >> Repair or replace damaged parts.

5. CHECK SYSTEM FOR ATP SWITCH

Perform trouble diagnosis for ATP switch system. Refer to [TF-64, "ATP Switch"](#) .

OK or NG

- OK >> GO TO 6.
- NG >> Repair or replace damaged parts.

6. SYMPTOM CHECK

Check again.

OK or NG

- OK >> Inspection End.
- NG >> GO TO 7.

7. CHECK TRANSFER CONTROL UNIT

Check transfer control unit input/output signal. Refer to [TF-27, "Transfer Control Unit Input/Output Signal Reference Values"](#) .

OK or NG

- OK >> GO TO 8.
- NG >> Check transfer control unit pin terminals for damage or loose connection with harness connector. If any items are damaged, repair or replace damaged parts.

8. CHECK TRANSFER INNER PARTS

1. Disassemble transfer assembly. Refer to [TF-88, "Disassembly and Assembly"](#) .

2. Check transfer inner parts.

OK or NG

- OK >> Inspection End.
- NG >> Repair or replace damaged parts.

ATP Warning Lamp Does Not Turn ON

SYMPTOM:

EDS001NK

ATP warning lamp does not turn ON when 4WD shift switch from "4H" to "4LO" or "4LO" to "4H" with A/T selector lever "P" position.

DIAGNOSTIC PROCEDURE

1. CHECK SYSTEM FOR CAN COMMUNICATION LINE

Perform self-diagnosis. Refer to [TF-36, "Self-Diagnostic Procedure"](#) .

Do the self-diagnostic results indicate CAN communication?

- YES >> Perform trouble diagnosis for CAN communication line. Refer to [LAN-7, "CAN COMMUNICATION"](#) .
- NO >> GO TO 2.

TROUBLE DIAGNOSIS FOR SYMPTOMS

2. CHECK SYSTEM FOR 4WD SHIFT SWITCH

Perform trouble diagnosis for 4WD shift switch system. Refer to [TF-45, "4WD Shift Switch"](#) .

OK or NG

- OK >> GO TO 3.
- NG >> Repair or replace damaged parts.

3. CHECK SYSTEM FOR PNP SWITCH SIGNAL

Perform trouble diagnosis for PNP switch signal system. Refer to [TF-52, "PNP Switch Signal \(TCM\)"](#) .

OK or NG

- OK >> GO TO 4.
- NG >> Repair or replace damaged parts.

4. CHECK SYSTEM FOR ATP SWITCH

Perform trouble diagnosis for ATP switch system. Refer to [TF-64, "ATP Switch"](#) .

OK or NG

- OK >> GO TO 5.
- NG >> Repair or replace damaged parts.

5. CHECK ATP WARNING LAMP CIRCUIT

1. Turn ignition switch "ON".
2. Disconnect ATP switch harness connector.
3. Check voltage between ATP switch harness connector terminal and ground.

Connector	Terminal (Wire color)	Condition		Voltage (Approx.)
F55	8 (R/B) - Ground	Ignition switch : ON	A/T selector lever "P" position	Battery voltage
			Except the above	0V

OK or NG

- OK >> GO TO 9.
- NG >> GO TO 6.

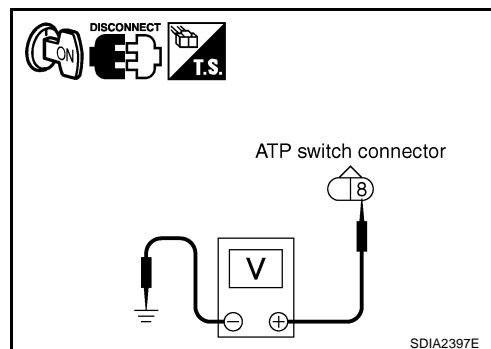

6. CHECK HARNESS BETWEEN TRANSFER CONTROL UNIT AND COMBINATION METER

1. Turn ignition switch "OFF".
2. Disconnect transfer control unit harness connector and combination meter harness connector.
3. Check continuity between transfer control unit harness connector E143 terminal 39 (L/B) and combination meter harness connector M24 terminal 6 (L/B).

Continuity should exist.

Also check harness for short to ground and short to power.

OK or NG

- OK >> GO TO 7.
- NG >> Repair or replace damaged parts.

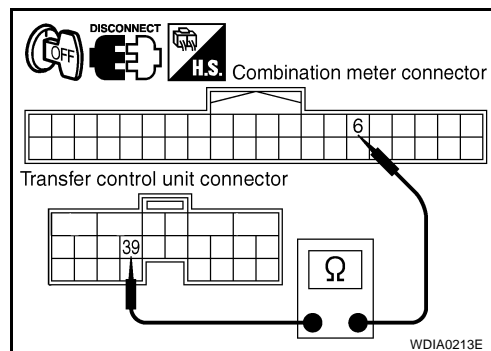

TROUBLE DIAGNOSIS FOR SYMPTOMS

7. CHECK HARNESS BETWEEN COMBINATION METER AND ATP SWITCH

1. Turn ignition switch "OFF".
2. Disconnect combination meter harness connector and ATP switch harness connector.
3. Check continuity between combination meter harness connector M24 terminal 7 (R/B) and ATP switch harness connector F55 terminal 8 (R/B).

Continuity should exist.

Also check harness for short to ground and short to power.

OK or NG

- OK >> GO TO 8.
NG >> Repair or replace damaged parts.

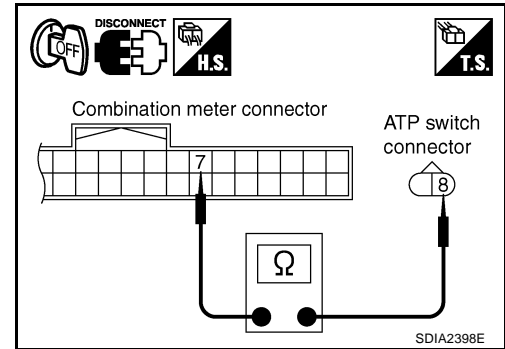

8. CHECK ATP WARNING LAMP CIRCUIT

1. Turn ignition switch "OFF".
2. Check the combination meter. Refer to [DI-5, "COMBINATION METERS"](#).

OK or NG

- OK >> GO TO 9.
NG >> Replace the combination meter. Refer to [IP-13, "COMBINATION METER"](#).

9. SYMPTOM CHECK

Check again.

OK or NG

- OK >> Inspection End.
NG >> GO TO 10.

10. CHECK TRANSFER CONTROL UNIT

Check transfer control unit input/output signal. Refer to [TF-27, "Transfer Control Unit Input/Output Signal Reference Values"](#).

OK or NG

- OK >> GO TO 11.
NG >> Check transfer control unit pin terminals for damage or loose connection with harness connector. If any items are damaged, repair or replace damaged parts.

11. CHECK TRANSFER INNER PARTS

1. Disassemble transfer assembly. Refer to [TF-88, "Disassembly and Assembly"](#).
2. Check transfer inner parts.

OK or NG

- OK >> Inspection End.
NG >> Repair or replace damaged parts.

4WD Shift Indicator Lamp Repeats Flashing SYMPTOM:

4WD shift indicator lamp keeps flashing.

EDS001NL

TROUBLE DIAGNOSIS FOR SYMPTOMS

DIAGNOSTIC PROCEDURE

1. CONFIRM THE SYMPTOM

1. Set 4WD shift switch to "2WD".
2. Move vehicle forward and backward, or drive straight increasing or decreasing under 20 km/h (12 MPH).

Does 4WD shift indicator lamp keep flashing?

- YES >> GO TO 2.
NO >> Inspection End.

2. CHECK SYSTEM FOR WAIT DETECTION SWITCH

Perform trouble diagnosis for wait detection switch system. Refer to [TF-49, "Wait Detection Switch"](#) .

OK or NG

- OK >> GO TO 3.
NG >> Repair or replace damaged parts.

3. CHECK SYSTEM FOR 4LO SWITCH

Perform trouble diagnosis for 4LO switch system. Refer to [TF-42, "4LO Switch"](#) .

OK or NG

- OK >> GO TO 4.
NG >> Repair or replace damaged parts.

4. SYMPTOM CHECK

Check again.

OK or NG

- OK >> Inspection End.
NG >> GO TO 5.

5. CHECK TRANSFER CONTROL UNIT

Check transfer control unit input/output signal. Refer to [TF-27, "Transfer Control Unit Input/Output Signal Reference Values"](#) .

OK or NG

- OK >> GO TO 6.
NG >> Check transfer control unit pin terminals for damage or loose connection with harness connector.
If any items are damaged, repair or replace damaged parts.

6. CHECK TRANSFER INNER PARTS

1. Disassemble transfer assembly. Refer to [TF-88, "Disassembly and Assembly"](#) .
2. Check transfer inner parts.

OK or NG

- OK >> Inspection End.
NG >> Repair or replace damaged parts.

4WD Warning Lamp Flashes Slowly

EDS001NM

SYMPTOM:

While driving, 4WD warning lamp flashes slowly. (When continuing to flash until turning ignition switch OFF.)

NOTE:

Slow flashing: 1 time/2 seconds

TROUBLE DIAGNOSIS FOR SYMPTOMS

DIAGNOSTIC PROCEDURE

1. CHECK TIRE

Check the following.

- Tire pressure
- Wear condition
- Longitudinal tire size (There is no difference between longitudinal tires.)

OK or NG

- OK >> GO TO 2.
- NG >> Repair or replace damaged parts.

2. SYMPTOM CHECK

Check again.

OK or NG

- OK >> Inspection End.
- NG >> GO TO 3.

3. CHECK TRANSFER CONTROL UNIT

Check transfer control unit input/output signal. Refer to [TF-27, "Transfer Control Unit Input/Output Signal Reference Values"](#) .

OK or NG

- OK >> Inspection End.
- NG >> Check transfer control unit pin terminals for damage or loose connection with harness connector.
If any items are damaged, repair or replace damaged parts.

TRANSFER CONTROL UNIT

TRANSFER CONTROL UNIT

PFP:33084

Removal and Installation

EDS001NN

REMOVAL

1. Switch 4WD shift switch to 2WD and set transfer assembly to 2WD.
2. Remove the glove box assembly. Refer to [IP-14, "LOWER INSTRUMENT PANEL RH AND GLOVE BOX"](#).
3. Disconnect transfer control unit connectors.
4. Remove the transfer control unit.

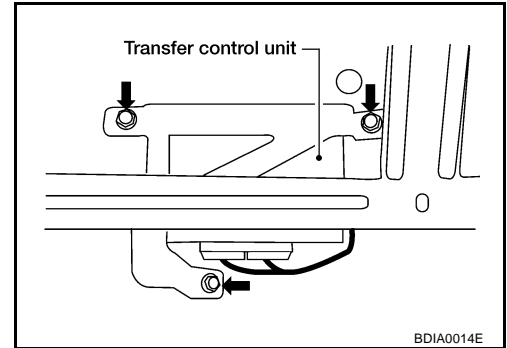

INSTALLATION

Note the following, and install in the reverse order of removal.

- When installing the transfer control unit, tighten bolts to the specified torque.
Transfer control unit bolts : 5.1 N·m (0.52 kg·m, 45 in·lb)
- After the installation, check 4WD shift indicator pattern. If NG, adjust position between transfer assembly and transfer control unit. Refer to [TF-4, "Precautions for Transfer Assembly and Transfer Control Unit Replacement"](#).

FRONT OIL SEAL

PFP:38189

FRONT OIL SEAL

Removal and Installation REMOVAL

EDS001NO

1. Partially drain transfer fluid. Refer to [MA-24, "Changing Transfer Fluid"](#) .
2. Remove front propeller shaft. Refer to [PR-4, "Removal and Installation"](#) .
3. Remove companion flange self-lock nut, using Tool.

Tool number : KV40104000 (—)

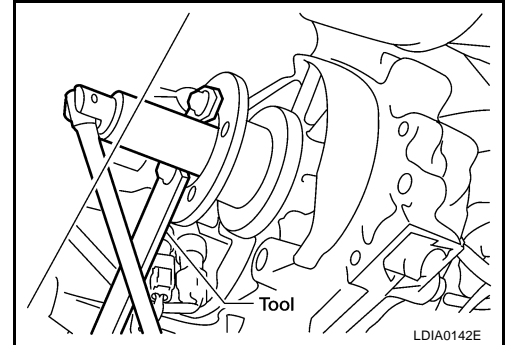

4. Put a matching mark on top of the front drive shaft in line with the mark on the companion flange.

CAUTION:

Use paint to make the matching mark on the front drive shaft. Do not damage the front drive shaft.

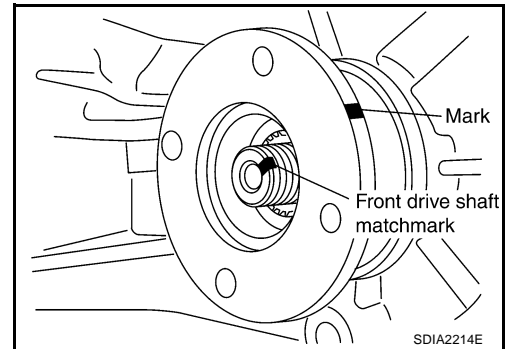

5. Remove companion flange, using suitable tool.

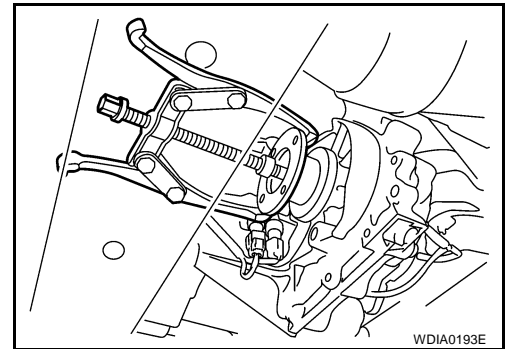

6. Remove front oil seal from front case, using Tool.

Tool number : ST33290001 (J-34286)

CAUTION:

Do not damage the front case.

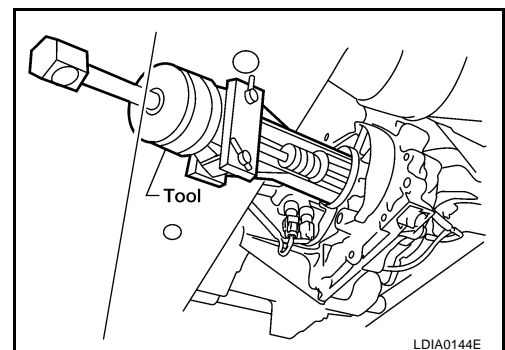

FRONT OIL SEAL

INSTALLATION

1. Install front oil seal until it is flush with end face of front case, using Tool.

Tool number : KV38100500 (—)

CAUTION:

- Do not reuse oil seal.
- Apply petroleum jelly to oil seal.

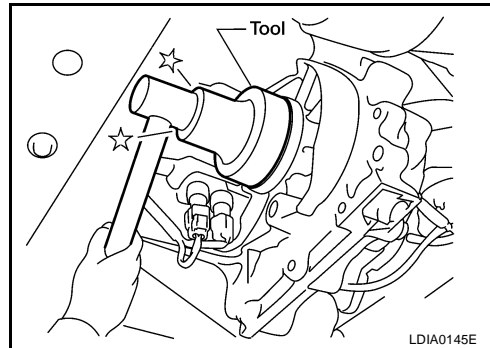

2. Align the matching mark of the front drive shaft with the matching mark of the companion flange, then install the companion flange.

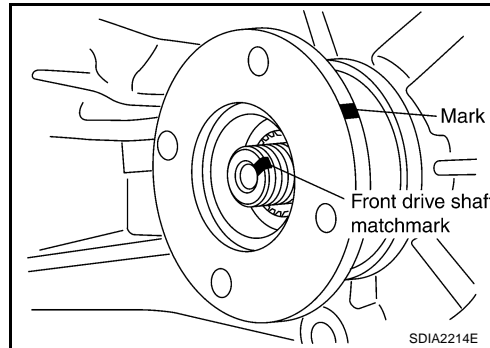

3. Tighten self-lock nut to the specified torque, using Tool. Refer to [TF-88, "COMPONENTS"](#).

Tool number : KV40104000 (—)

CAUTION:

Do not reuse self-lock nut.

4. Install front propeller shaft. Refer to [PR-4, "Removal and Installation"](#).
5. Refill the transfer fluid and check fluid level and for fluid leakage. Refer to [MA-25, "FLUID LEAKAGE AND FLUID LEVEL"](#).

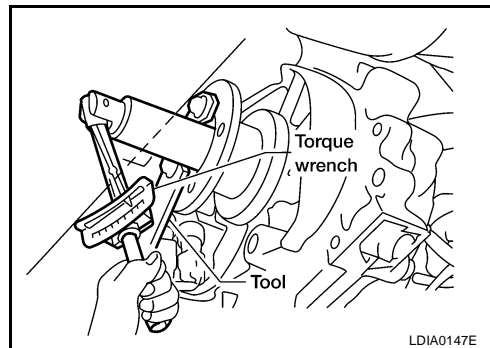

REAR OIL SEAL

PFP:33140

EDS001NP

REAR OIL SEAL

Removal and Installation

REMOVAL

1. Partially drain transfer fluid. Refer to [MA-24, "DRAINING"](#) .
2. Remove the rear propeller shaft. Refer to [PR-9, "REMOVAL"](#) .
3. Remove dust cover from rear case.

CAUTION:

Do not damage the rear case.

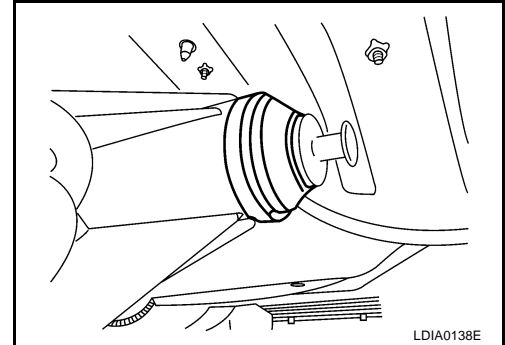

4. Remove rear oil seal from rear case, using Tool.

CAUTION:

Do not damage the rear case.

Tool number : ST33290001 (J-34286)

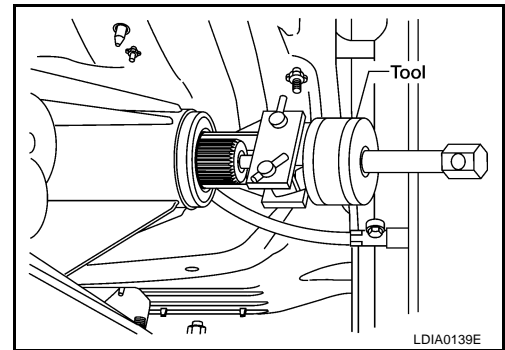

INSTALLATION

1. Install the rear oil seal until it is flush with the end face of the rear case using Tool.

Tool number : KV38100500 (—)

CAUTION:

- Do not reuse oil seal.
- Apply petroleum jelly to oil seal.

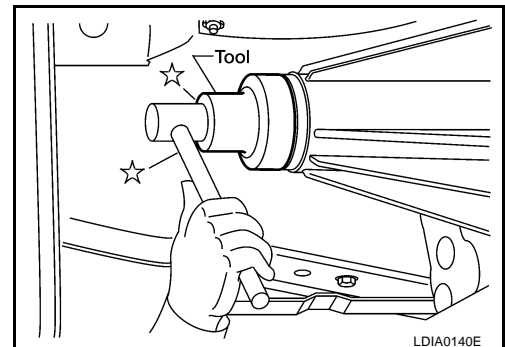

2. Apply petroleum jelly to the circumference of the new dust cover. Position the dust cover using the identification mark as shown.

CAUTION:

- Do not reuse dust cover.
- Position the identification mark at the position shown.

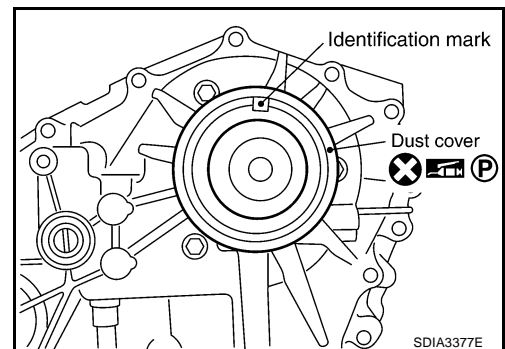

REAR OIL SEAL

3. Install the dust cover to the rear case using Tool.

Tool number : KV40105310 (—)

CAUTION:

- Do not reuse dust cover.
- Apply petroleum jelly to dust cover.

4. Install the rear propeller shaft. Refer to [PR-10, "INSTALLATION"](#).
5. Refill the transfer with fluid and check fluid level. Refer to [MA-25, "FILLING"](#).
6. Check the transfer for fluid leakage. Refer to [MA-25, "FLUID LEAKAGE AND FLUID LEVEL"](#).

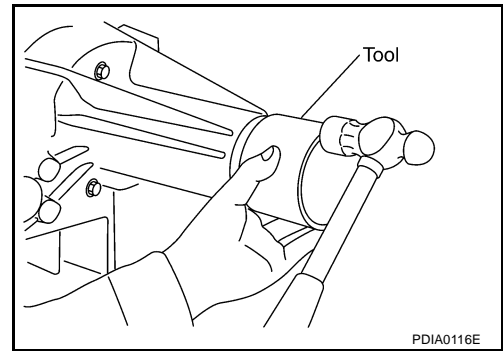

A
B
C

TF

E
F
G
H
I
J
K
L
M

TRANSFER CONTROL DEVICE

TRANSFER CONTROL DEVICE

PFP:33251

Removal and Installation

EDS001N0

REMOVAL

1. Switch 4WD shift switch to 2WD and set transfer assembly to 2WD.
2. Disconnect transfer control device harness connector.
3. Remove breather hose from transfer control device.
4. Remove bolts and detach control device.

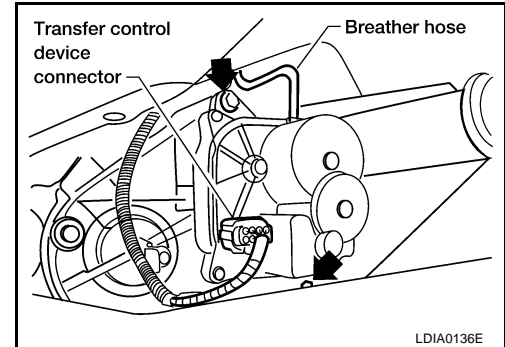

INSTALLATION

1. Install O-ring to transfer control device.

CAUTION:

- Do not reuse O-ring.
- Apply petroleum jelly.

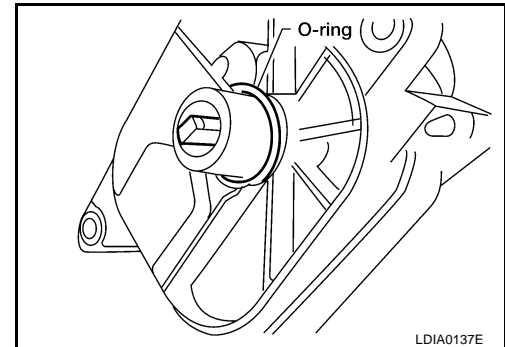

2. Install transfer control device.
 - a. Turn control shift rod fully counterclockwise using flat-bladed screwdriver, and then put mark on control shift rod.

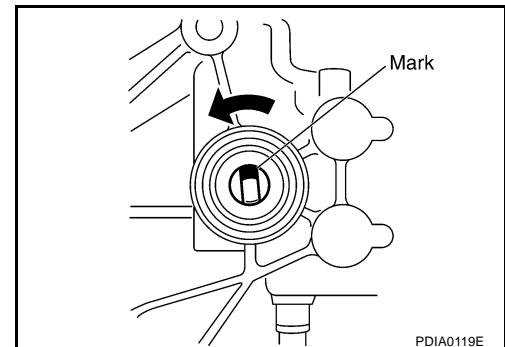

- b. Align transfer control device shaft cutout with mark on control shift rod, and install.

NOTE:

Turn transfer control device when transfer control device connection does not match.

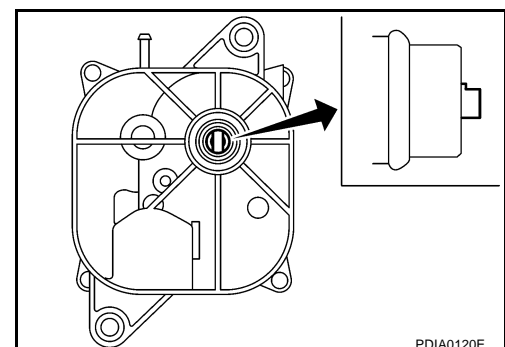

TRANSFER CONTROL DEVICE

- c. Tighten bolts to the specified torque. Refer to [TF-88, "COMPONENTS"](#).
3. Install breather hose to transfer control device.
4. Connect transfer control device harness connector.
5. After the installation, check 4WD shift indicator pattern. If NG, adjust position between transfer assembly and transfer control unit. Refer to [TF-4, "Precautions for Transfer Assembly and Transfer Control Unit Replacement"](#).

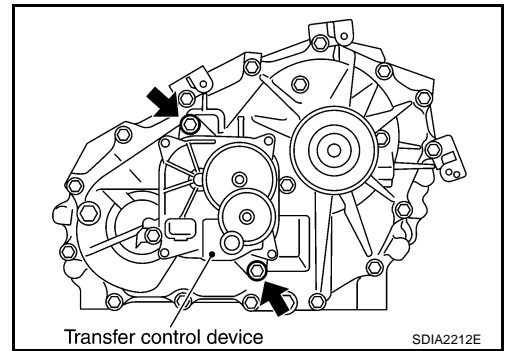

A

B

C

TF

E

F

G

H

I

J

K

L

M

AIR BREATHER HOSE

PFP:31098

AIR BREATHER HOSE Removal and Installation

EDS001NR

Refer to the figure for air breather hose removal and installation information.

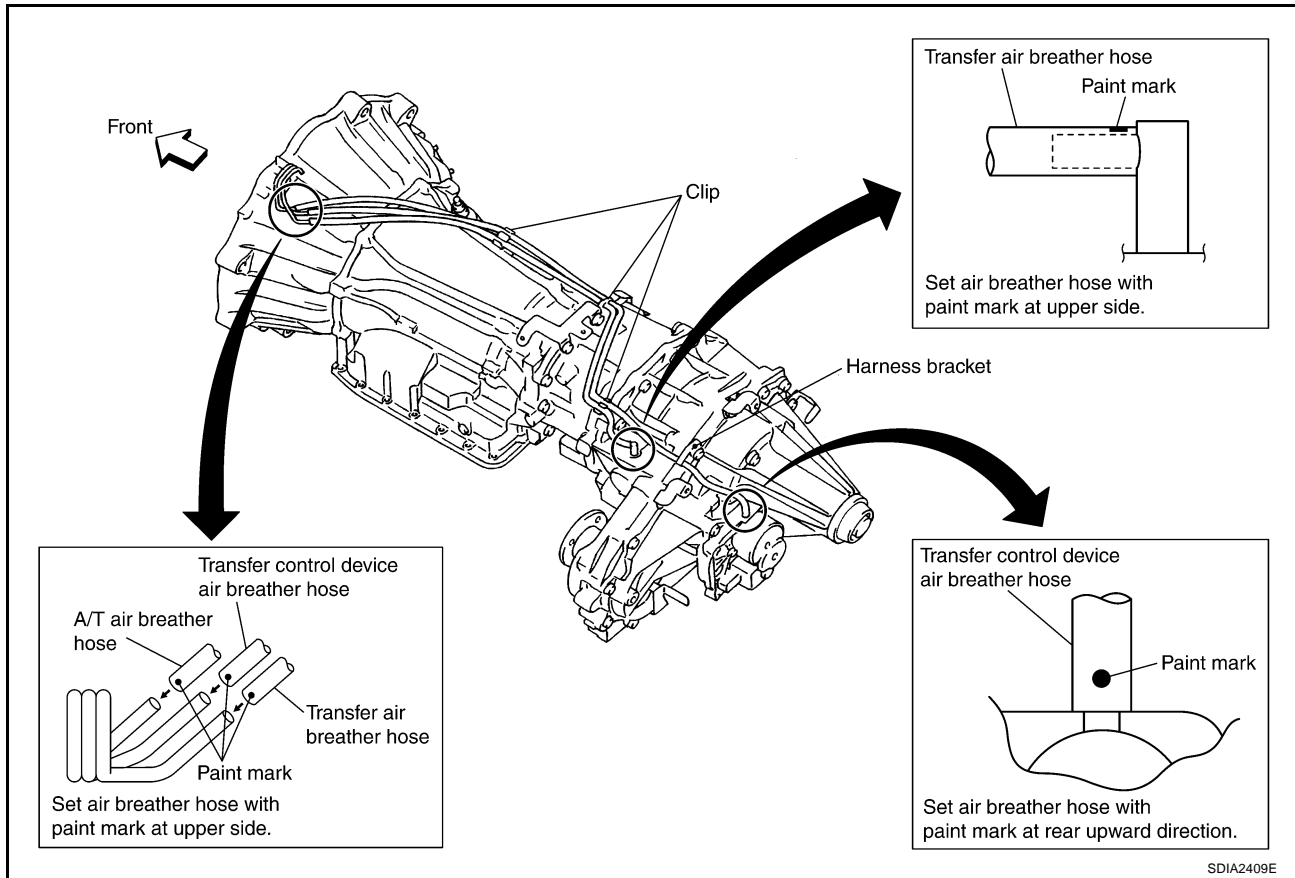

CAUTION:

- Make sure there are no pinched or restricted areas on the air breather hose caused by bending or twisting when installing it.
- Install air breather hose into breather tube (metal connector) and transfer control device (case connector) until hose end reaches the base of the tube.

TRANSFER ASSEMBLY

PF3:33100

EDS001NS

TRANSFER ASSEMBLY

Removal and Installation

REMOVAL

1. Switch 4WD shift switch to 2WD and set transfer assembly to 2WD.
2. Remove A/T undercover using power tools.
3. Remove center exhaust tubes and muffler. Refer to [EX-4, "REMOVAL"](#) .
4. Remove front and rear propeller shafts. Refer to [PR-5, "REMOVAL"](#) (front), [PR-9, "REMOVAL"](#) (rear).

CAUTION:

Do not damage spline, sleeve yoke or rear oil seal when removing the rear propeller shaft.

NOTE:

Insert a plug into rear oil seal after removing rear propeller shaft.

5. Remove A/T bolts. Refer to [AT-268, "COMPONENTS"](#) .
6. Position two suitable jacks under A/T and transfer assembly.
7. Remove A/T crossmember. Refer to [AT-268, "COMPONENTS"](#) .

WARNING:

Support A/T and transfer assembly using two suitable jacks while removing A/T crossmember.

8. Remove breather hoses from the transfer rear case and transfer control device.
9. Disconnect the electrical connectors from the following:
 - ATP switch
 - 4LO switch
 - Wait detection switch
 - Transfer control device
10. Remove transfer to A/T and A/T to transfer bolts.

WARNING:

Support transfer assembly using suitable jack while removing it.

11. Remove transfer assembly.

CAUTION:

Do not damage rear oil seal (A/T).

INSTALLATION

Install in the reverse order of removal.

- When installing the transfer to the transmission, install the bolts to the specified torque.

Tightening torque : 36 N·m (3.7kg-m, 26 ft-lb)

- Check the fluid level and for fluid leakage. Refer to [MA-24, "Changing Transfer Fluid"](#) .
- After the installation, check 4WD shift indicator pattern. If NG, adjust position between transfer assembly and transfer control unit. Refer to [TF-4, "Precautions for Transfer Assembly and Transfer Control Unit Replacement"](#) .

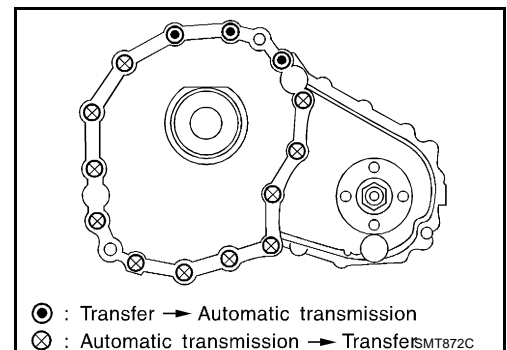

TRANSFER ASSEMBLY

EDS001NT

Disassembly and Assembly COMPONENTS

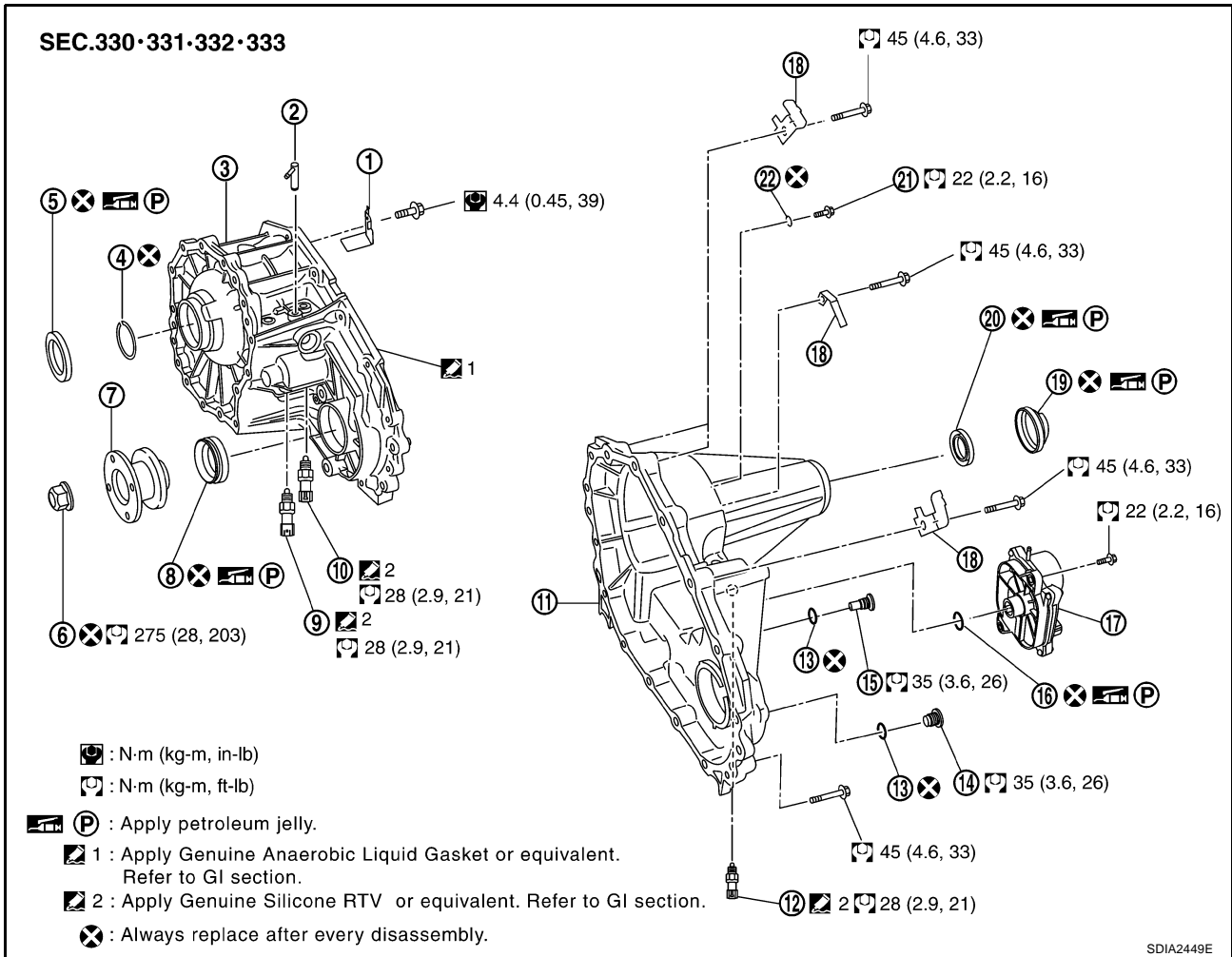

- | | | |
|------------------------|-----------------------------|---------------------------------------|
| 1. Baffle plate | 2. Breather tube | 3. Front case |
| 4. Snap ring | 5. Input oil seal | 6. Self-lock nut |
| 7. Companion flange | 8. Front oil seal | 9. 4LO switch (gray with green paint) |
| 10. ATP switch (black) | 11. Rear case | 12. Wait detection switch (gray) |
| 13. Gasket | 14. Filler plug | 15. Drain plug |
| 16. O-ring | 17. Transfer control device | 18. Harness bracket |
| 19. Dust cover | 20. Rear oil seal | 21. Retainer bolt |
| 22. Gasket | | |

TRANSFER ASSEMBLY

SEC.332•333

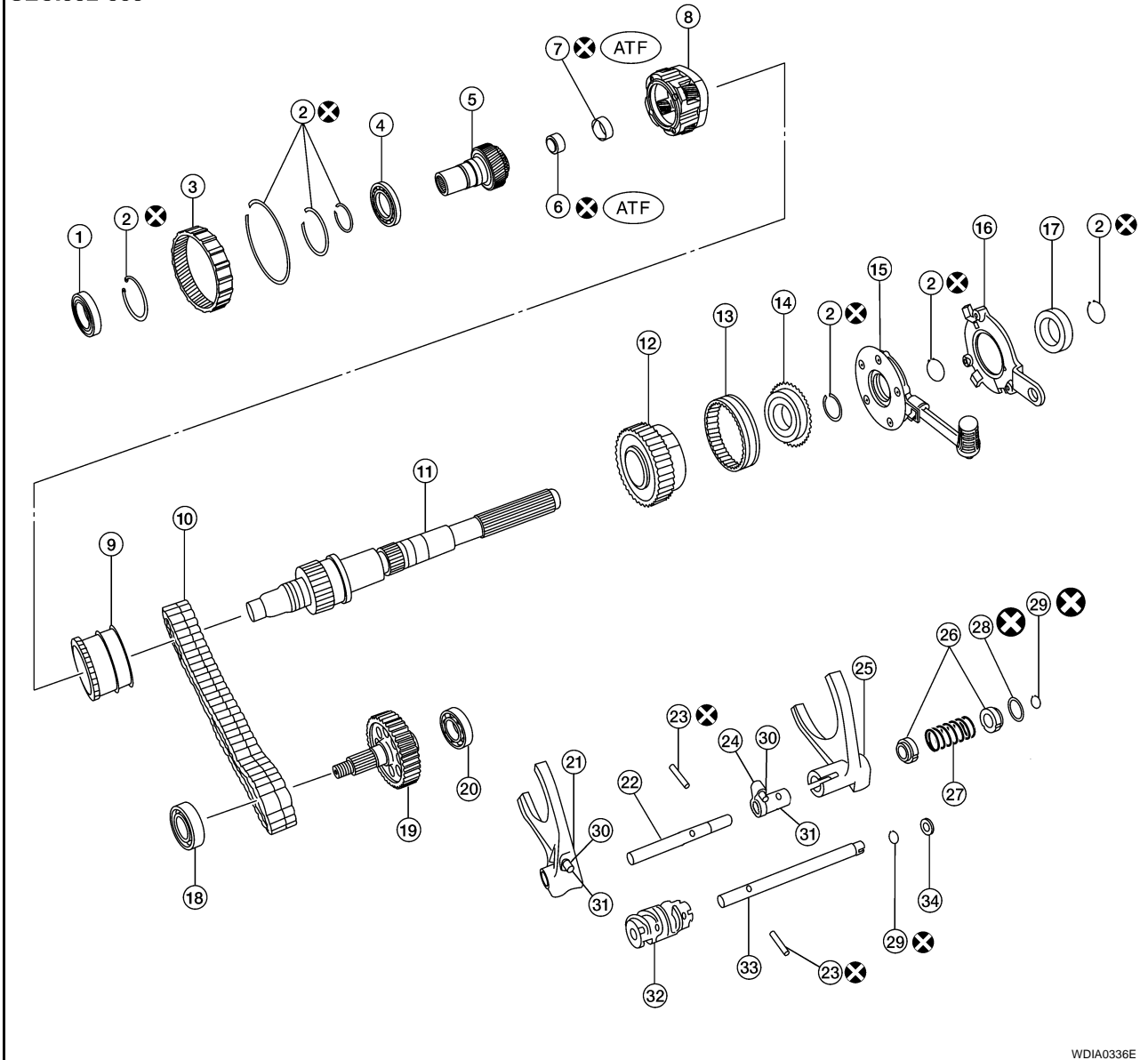

- | | | |
|-----------------------|-------------------------------|---------------------------|
| 1. Input bearing | 2. Snap ring | 3. Internal gear |
| 4. Carrier bearing | 5. Sun gear | 6. Needle bearing |
| 7. Metal bushing | 8. Planetary carrier assembly | 9. L-H sleeve |
| 10. Drive chain | 11. Mainshaft | 12. Sprocket |
| 13. 2-4 sleeve | 14. Clutch gear | 15. Oil pump assembly |
| 16. Retainer | 17. Mainshaft rear bearing | 18. Front bearing |
| 19. Front drive shaft | 20. Rear bearing | 21. L-H shift fork |
| 22. L-H shift rod | 23. Retaining pin | 24. 2-4 shift bracket |
| 25. 2-4 shift fork | 26. Fork guide collar | 27. 2-4 shift fork spring |
| 28. Retaining ring | 29. Snap ring | 30. Shift collar |
| 31. Clevis pin | 32. Drum cam | 33. Control shift rod |
| 34. Spacer | | |

WDIA0336E

TRANSFER ASSEMBLY

DISASSEMBLY

1. Remove drain plug and filler plug.
2. Remove transfer control device from rear case.
3. Remove O-ring form transfer control device.

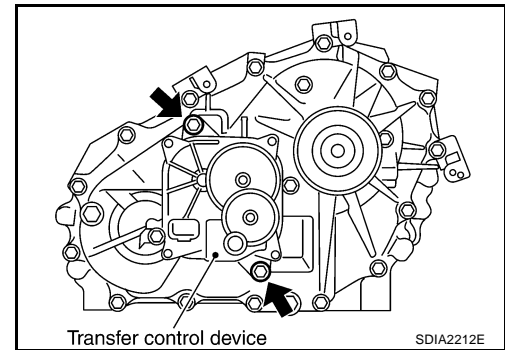

4. Remove the self-lock nut from the companion flange, using Tool.
Tool number : KV40104000 (—)

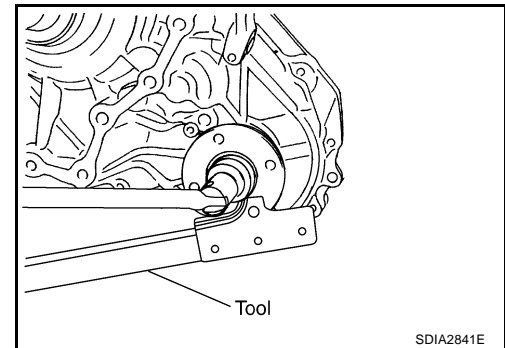

5. Put a matching mark on top of the front drive shaft in line with the mark on the companion flange.

CAUTION:

Use paint to make the matching mark on the front drive shaft. Do not damage the front drive shaft.

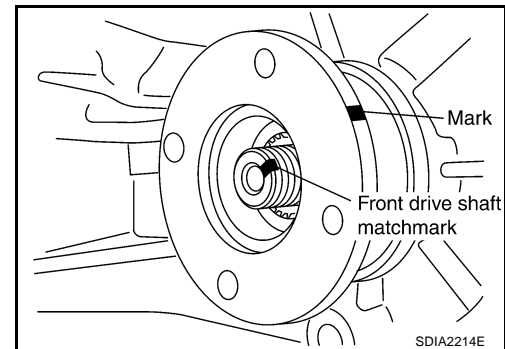

6. Remove the companion flange, using suitable tool.

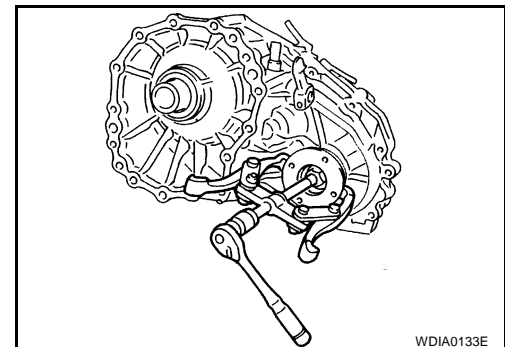

TRANSFER ASSEMBLY

7. Remove front oil seal from front case, using Tool.

Tool number : ST33290001 (J-34286)

CAUTION:

Do not damage the front case or front drive shaft.

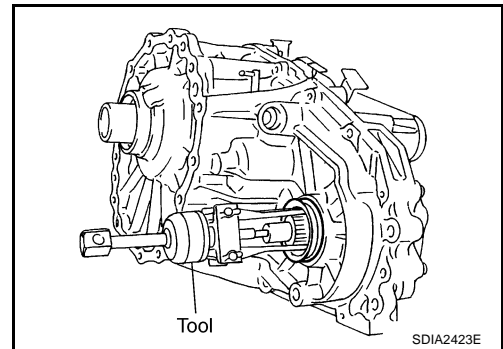

8. Remove the 4LO switch [gray (with green paint)] and ATP switch (black) from front case.

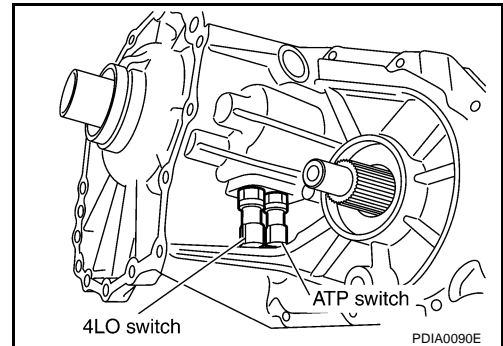

9. Remove wait detection switch (gray) from rear case.

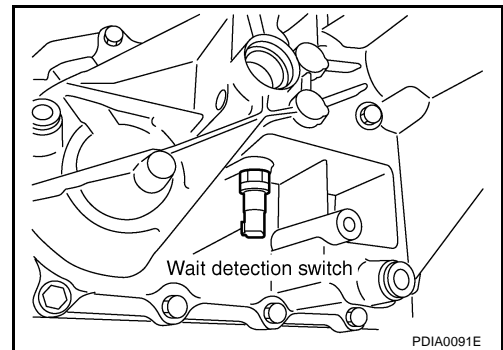

10. Remove dust cover from rear case, using suitable tool.

CAUTION:

Do not damage the rear case.

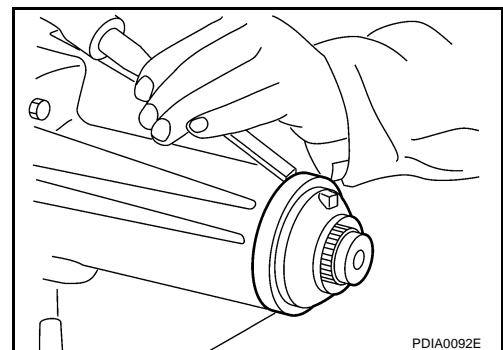

11. Remove rear oil seal from rear case, using Tool.

Tool number : ST33290001 (J-34286)

CAUTION:

Do not damage the rear case or mainshaft.

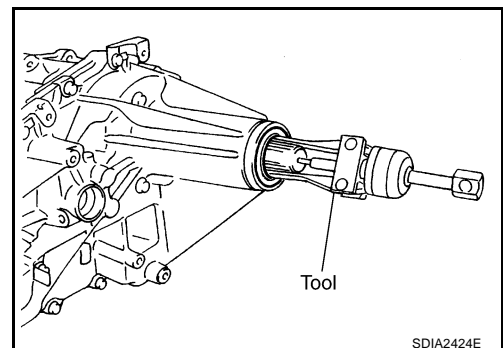

A
B
C
TF
E
F
G
H
I
J
K
L
M

TRANSFER ASSEMBLY

12. Remove the input oil seal from front case, using suitable tool.

CAUTION:

Do not damage the front case, sun gear or input bearing.

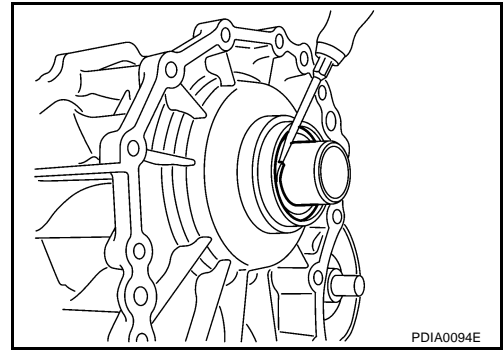

13. Remove the retainer bolts and gaskets.

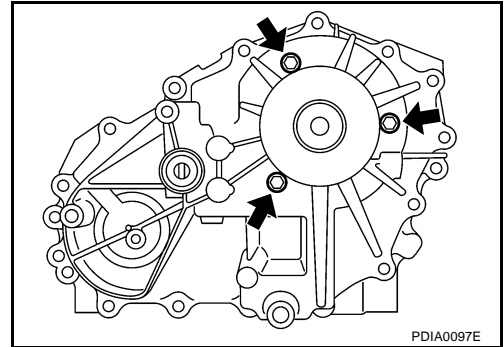

14. Remove rear case bolts and harness bracket from rear case.

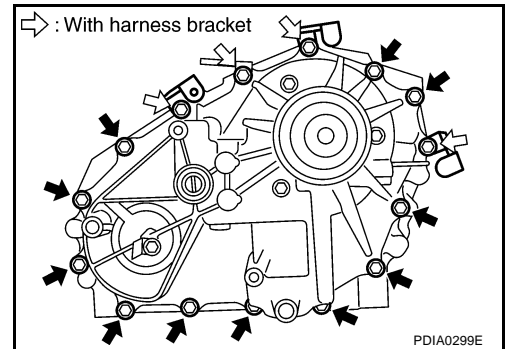

15. Separate front case and rear case. Then remove rear case by prying it up, using suitable tool.

CAUTION:

Do not damage the mating surface.

16. Remove spacer from the control shift rod.

CAUTION:

Do not drop spacer.

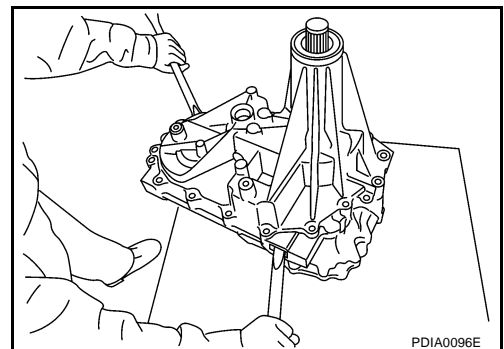

17. Remove snap ring from mainshaft, using suitable tool.

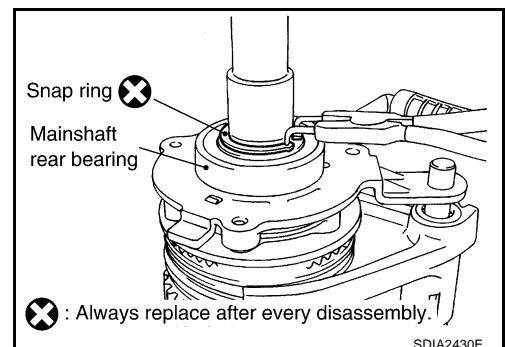

TRANSFER ASSEMBLY

18. Remove the mainshaft rear bearing from mainshaft, using suitable tool.
19. Remove retainer from mainshaft.

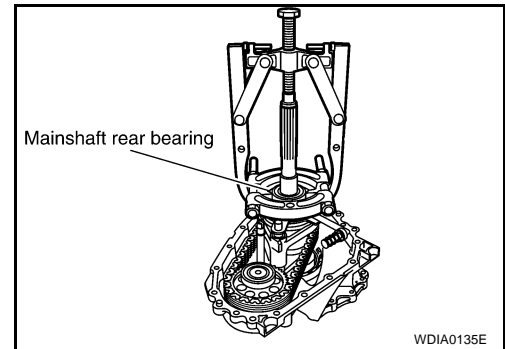

20. Remove snap ring from mainshaft, using suitable tool.
21. Remove oil pump assembly from mainshaft.

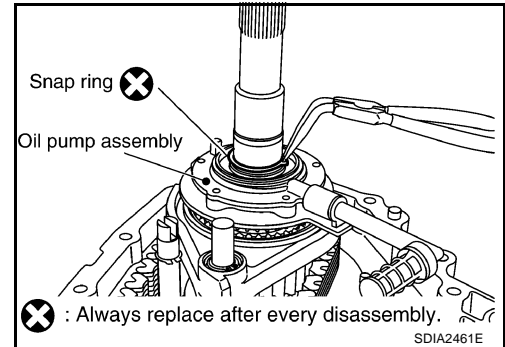

22. Remove snap ring from mainshaft, using suitable tool.
23. Remove clutch gear from mainshaft.

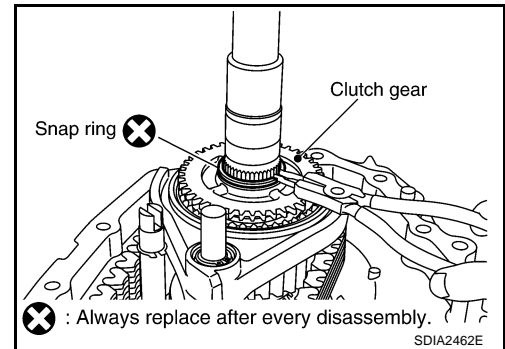

24. Remove snap ring from L-H shift rod assembly, using suitable tool.
25. Remove 2-4 sleeve and 2-4 shift fork assembly from mainshaft.

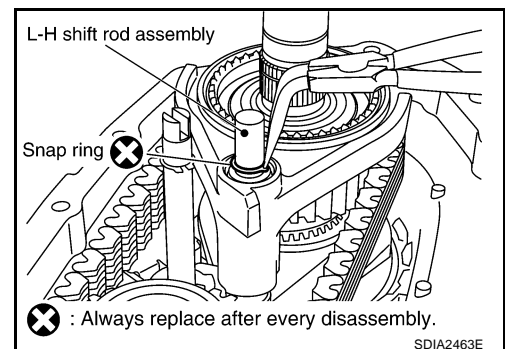

26. Remove drive chain together with sprocket and front drive shaft from front case.
27. Remove spacer and needle bearing from mainshaft.
28. Remove mainshaft from sun gear assembly.
29. Remove L-H shift rod assembly and control shift rod assembly from front case.
30. Remove L-H sleeve together with L-H shift fork assembly from planetary carrier assembly.

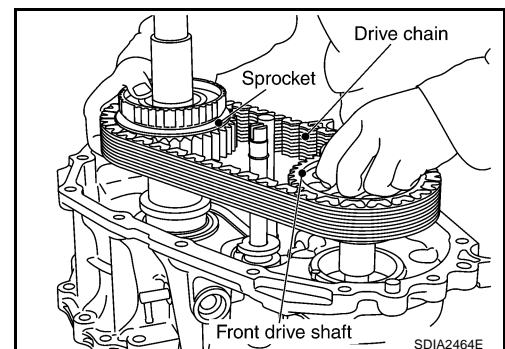

A
B
C
TF
E
F
G
H
I
J
K
L
M

TRANSFER ASSEMBLY

31. Remove snap ring from sun gear.

CAUTION:
Do not damage the sun gear or input bearing.

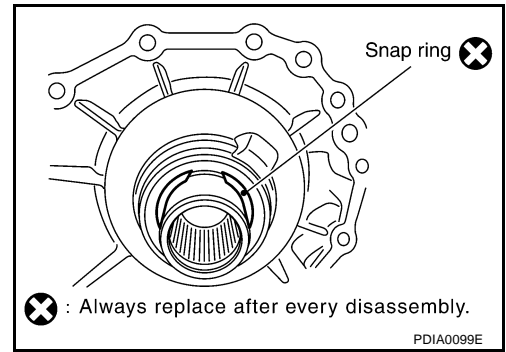

32. Press the sun gear assembly and planetary carrier assembly from front case, using Tool.

Tool number : KV38100200 (—)

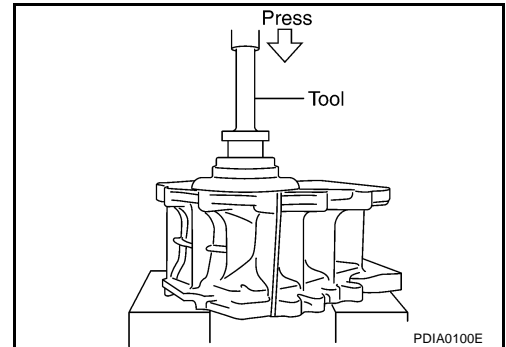

33. Remove snap ring from front case.

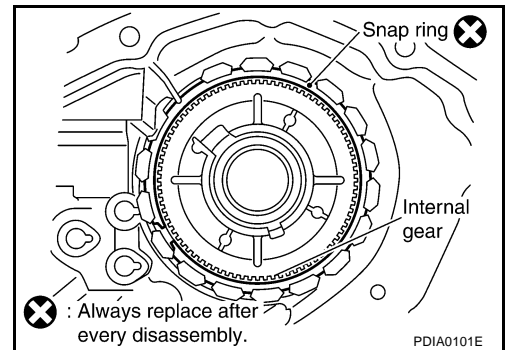

34. Remove internal gear from front case.

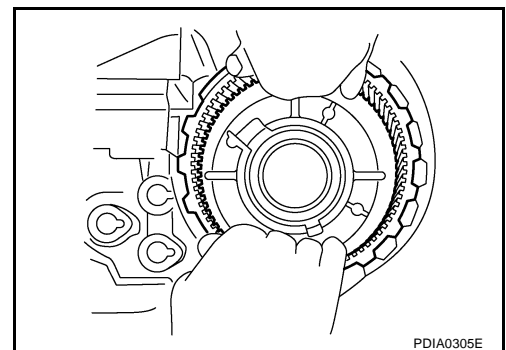

35. Remove snap ring from front case.

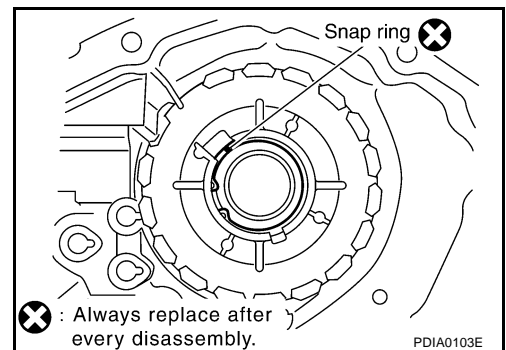

TRANSFER ASSEMBLY

36. Remove the input bearing from front case, using Tool.

Tool number : KV38100200 (—)

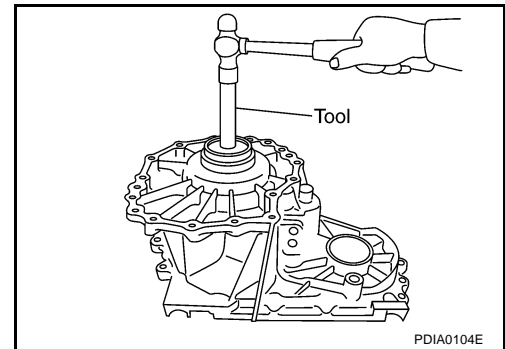

37. Remove baffle plate from front case.

38. Remove the breather tube from front case.

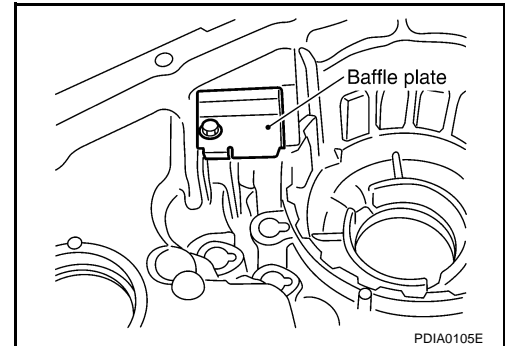

INSPECTION AFTER DISASSEMBLY

Case

Check contact surfaces of shift rod and bearing for wear and damage. If any is found, replace with new one.

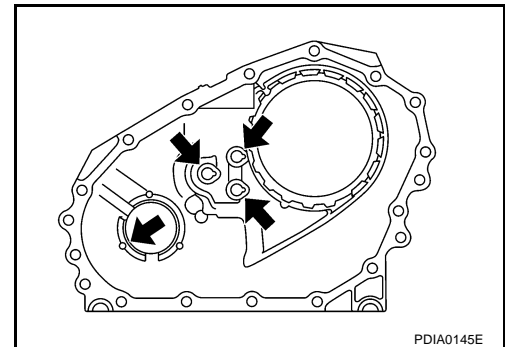

Sleeve

Check items below. If necessary, replace them with new one.

- Damage and excessive wear of contact surfaces of sprocket, mainshaft and sleeve.
- Sleeve must move smoothly.

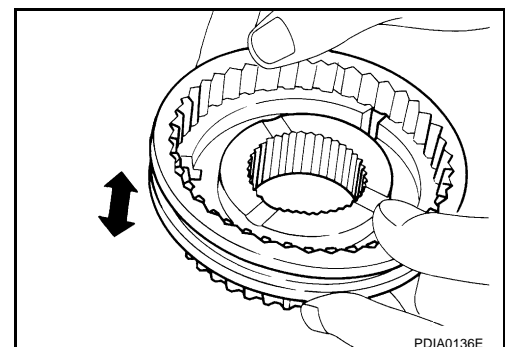

A
B
C
TF
E
F
G
H
I
J
K
L
M

TRANSFER ASSEMBLY

Gear, Shaft and Drive Chain

Check items below. If necessary, replace them with new ones.

- Damage, peeling, uneven wear and bending of the shaft.
- Excessive wear, damage and peeling of the gear.
- Excessive wear or damage to the drive chain

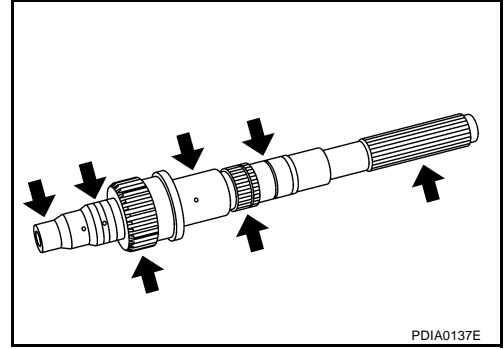

Bearing

Check the bearing for damage and rough rotation. If necessary, replace it with a new one.

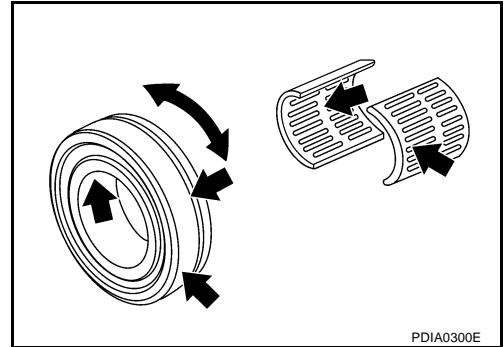

ASSEMBLY

1. Install breather tube.

CAUTION:

Install breather tube in the direction shown.

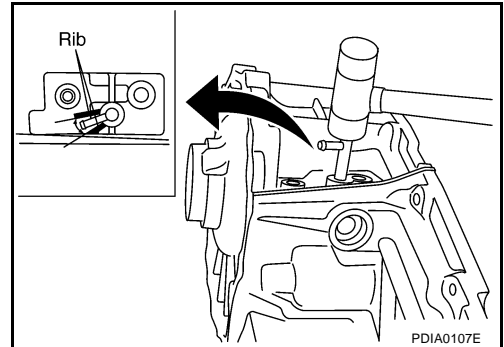

2. Install baffle plate to front case, and tighten bolt to the specified torque. Refer to [TF-88, "COMPONENTS"](#).

CAUTION:

Install baffle plate by pushing it in the direction shown while tightening the bolt.

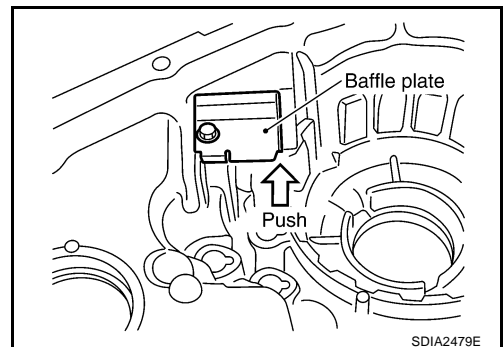

TRANSFER ASSEMBLY

3. Install the input bearing to front case, using Tool.

Tool number : ST30720000 (J-25405)

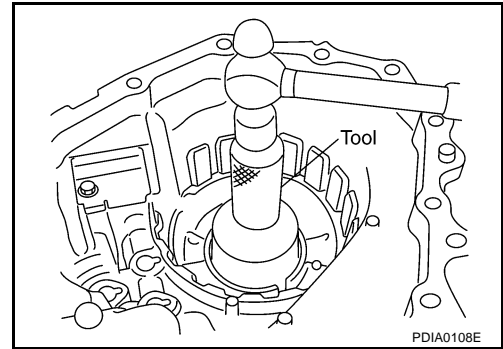

4. Install snap ring to front case.

CAUTION:
Do not reuse snap ring.

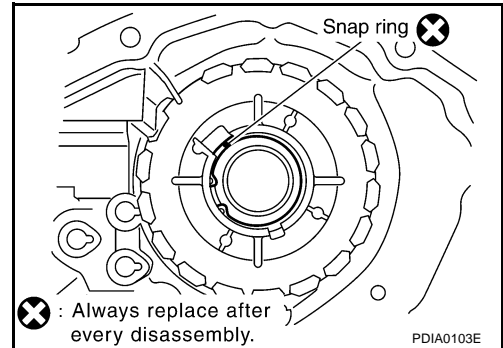

5. Install internal gear with groove facing up into front case.

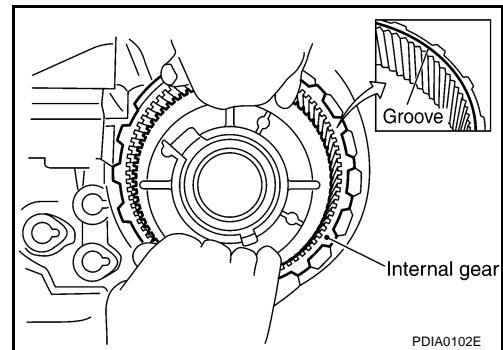

6. Install snap ring to front case.

CAUTION:
Do not reuse snap ring.

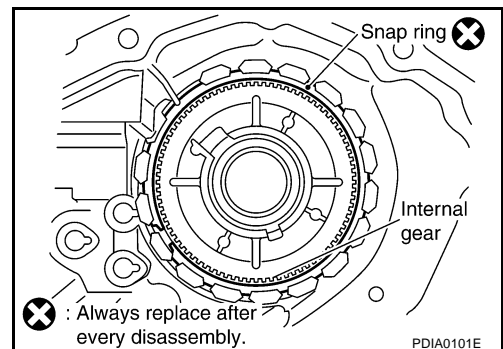

7. Install the planetary carrier assembly and sun gear assembly to front case, using Tool.

Tool number : KV38100200 (—)

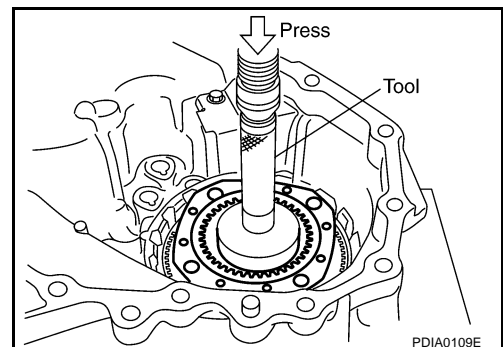

A
B
C
TF
E
F
G
H
I
J
K
L
M

TRANSFER ASSEMBLY

8. Install snap ring to sun gear.

CAUTION:

- Do not reuse snap ring.
- Do not damage the sun gear.

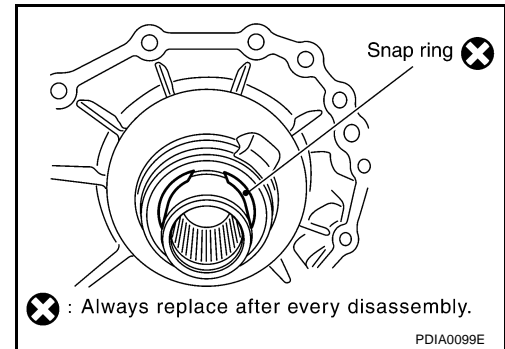

9. Set L-H sleeve together with L-H shift fork assembly onto planetary carrier assembly.

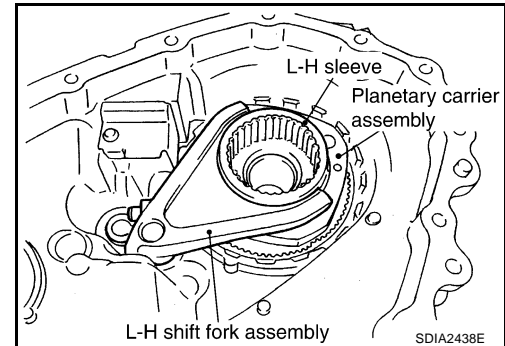

10. Install control shift rod assembly to front case.

CAUTION:

Set pin of L-H shift fork assembly into the groove of drum cam.

11. Turn control shift rod assembly fully counterclockwise.

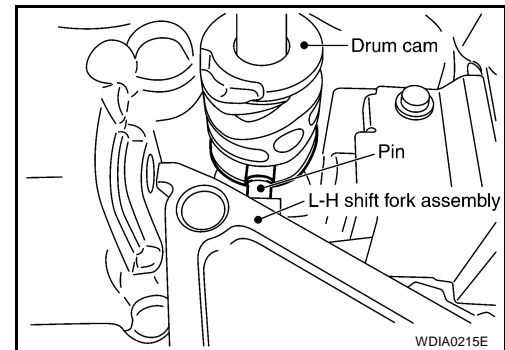

12. Install L-H shift rod assembly through L-H shift fork assembly opening to front case.

CAUTION:

Set pin of L-H shift rod assembly into the groove of drum cam.

13. Install mainshaft to sun gear assembly.

14. Apply ATF to spacer and periphery of needle bearing, install to mainshaft.

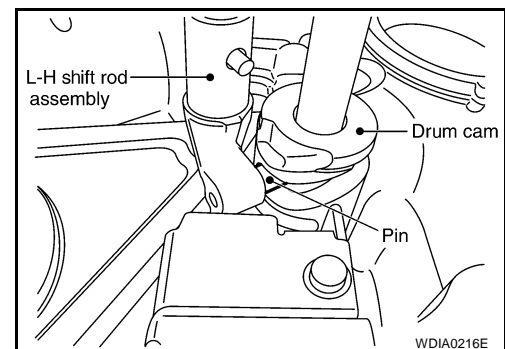

15. Set front drive shaft and sprocket to drive chain.

CAUTION:

Identification mark of drive chain should be on the side of rear bearing of front drive shaft.

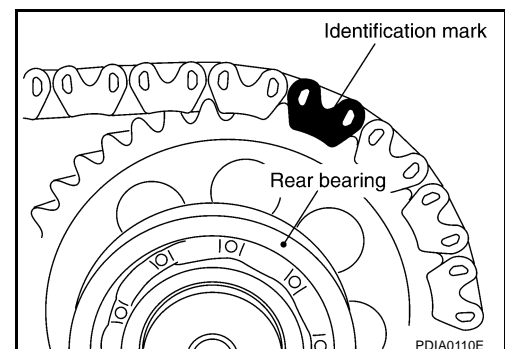

TRANSFER ASSEMBLY

16. Install drive chain together with front drive shaft and sprocket to front case.

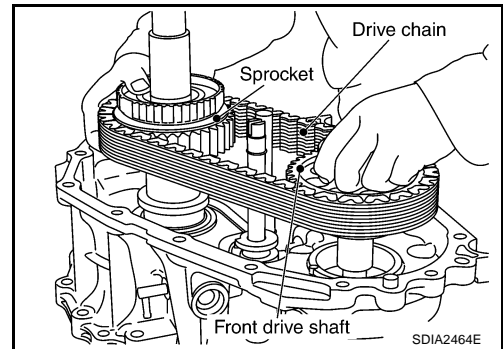

17. Install 2-4 sleeve and 2-4 shift fork assembly to mainshaft.

CAUTION:

- Install with proper orientation of 2-4 sleeve.
- Install 2-4 shift fork with engaging the grooves of 2-4 shift fork in the retaining pin of 2-4 shift bracket.

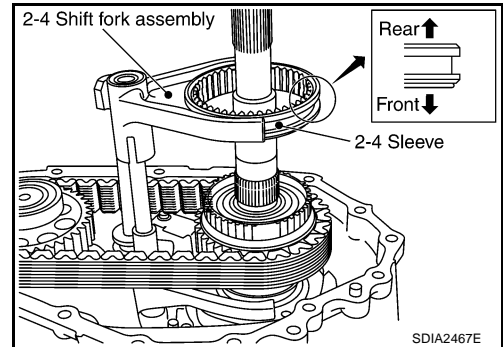

18. Install snap ring to L-H shift rod assembly, using suitable tool.

CAUTION:

Do not reuse snap ring.

19. Install clutch gear to mainshaft.

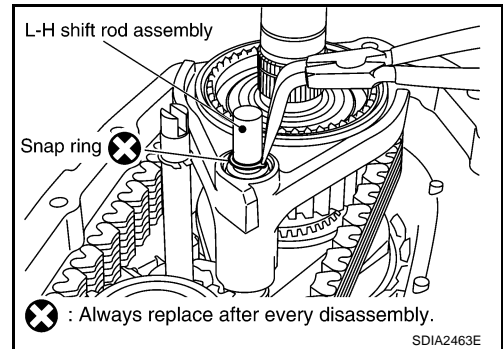

20. Install snap ring to mainshaft, using suitable tool.

CAUTION:

Do not reuse snap ring.

21. Install oil pump assembly to mainshaft.

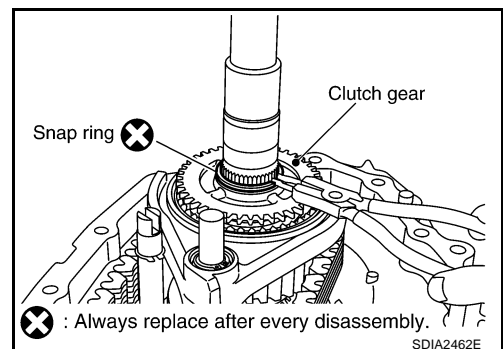

22. Install snap ring to mainshaft, using suitable tool.

CAUTION:

Do not reuse snap ring.

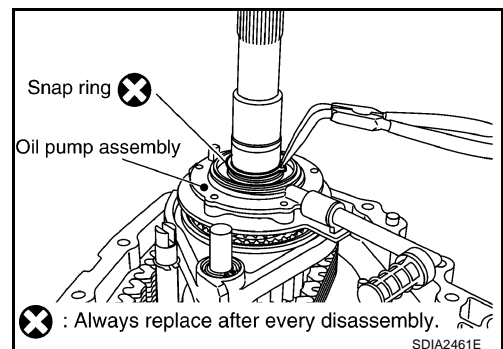

A
B
C
TF
E
F
G
H
I
J
K
L
M

TRANSFER ASSEMBLY

23. Install retainer to mainshaft.

CAUTION:

Set the projection of oil pump assembly to identification hole, and then align locating hole of retainer to L-H shift rod assembly.

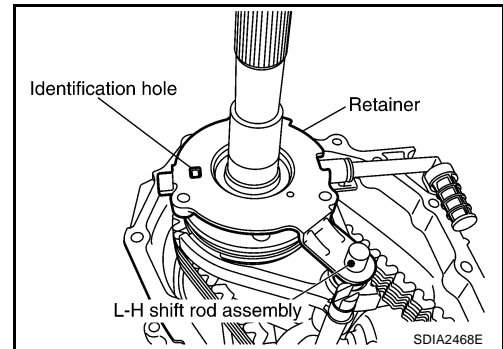

24. Install the mainshaft rear bearing to mainshaft, using Tool.

Tool number : KV32102700 (—)

CAUTION:

Do not push too hard in order to avoid snap rings becoming dislodged from mainshaft.

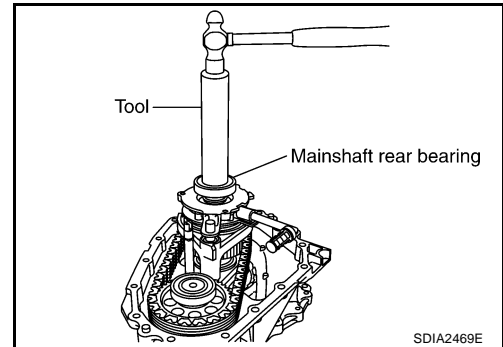

25. Install snap ring to mainshaft, using suitable tool.

CAUTION:

Do not reuse snap ring.

26. Install spacer to control shift rod.

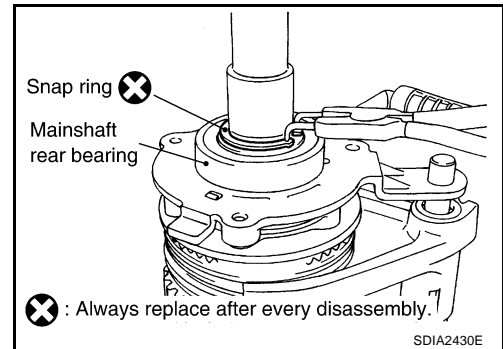

27. Apply liquid gasket to mating surface of front case.

- Use Genuine Anaerobic Liquid Gasket or equivalent. Refer to [GI-45, "Recommended Chemical Products and Sealants"](#).

CAUTION:

Remove old sealant adhering to mating surfaces. Also remove any moisture, oil, or foreign material adhering to application and mating surfaces.

28. Install rear case to front case.

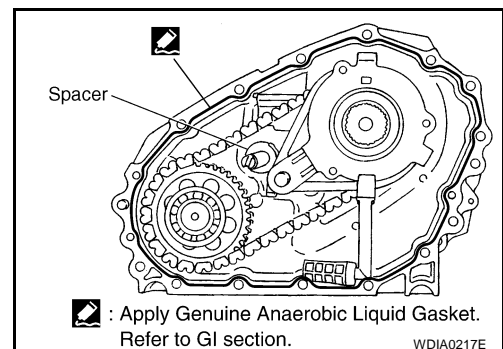

29. Tighten bolts to specified torque. Refer to [TF-88, "COMPONENTS"](#).

CAUTION:

Be sure to install the harness brackets.

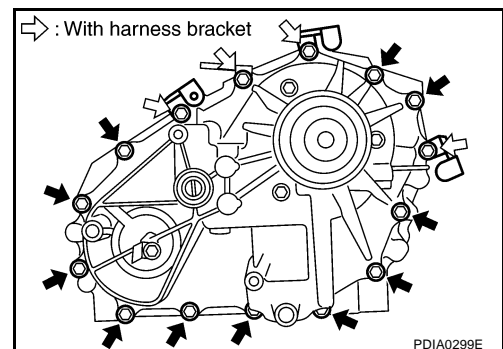

TRANSFER ASSEMBLY

30. Install the retainer bolts with new gaskets. Tighten the bolts to the specified torque. Refer to [TF-88, "COMPONENTS"](#).

CAUTION:

- Do not reuse gasket.
- Tighten them to the specified torque again.

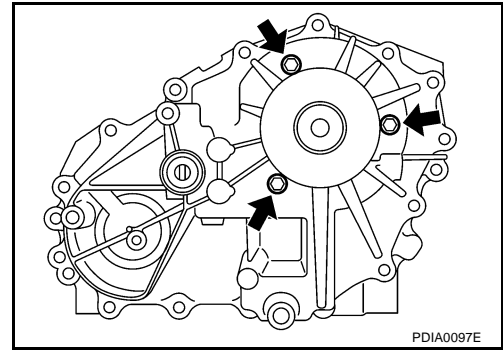

31. Install input oil seal to front case, using Tools.

Dimension A : 4.0 - 4.6 mm (0.157 - 0.181 in)

Tool number A: ST30720000 (J-25405)
B: KV40104830 (—)

CAUTION:

- Do not reuse oil seal.
- Apply petroleum jelly to oil seal.

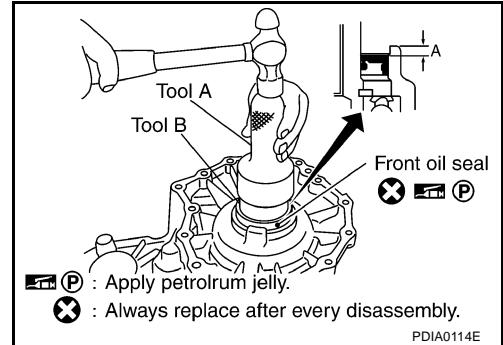

32. Install rear oil seal until it is flush with end face of rear case, using Tool.

Tool number : KV38100500 (—)

CAUTION:

- Do not reuse oil seal.
- Apply petroleum jelly to oil seal.

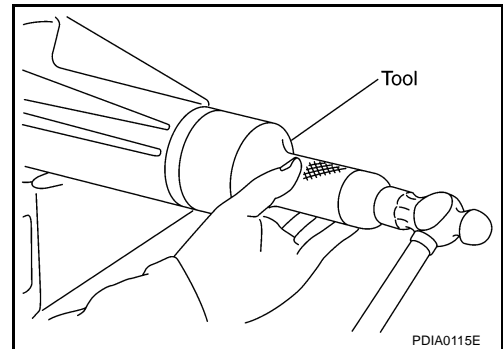

33. Apply petroleum jelly to the circumference of the new dust cover. Position the dust cover using the identification mark as shown.

CAUTION:

- Do not reuse dust cover.
- Position the identification mark at the position shown.

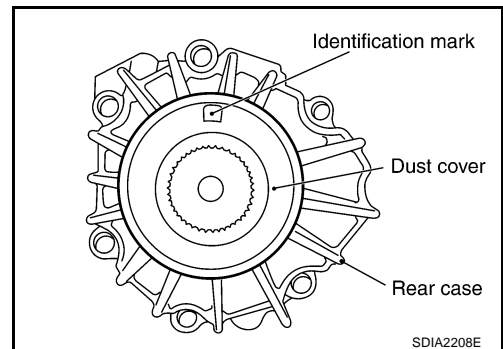

34. Install the dust cover to the rear case, using Tool.

Tool number : KV40105310 (—)

CAUTION:

- Do not reuse dust cover.
- Apply petroleum jelly to dust cover.

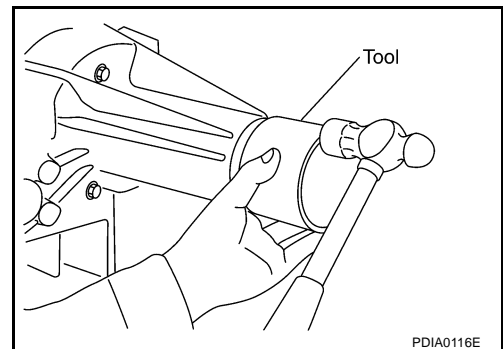

TRANSFER ASSEMBLY

35. Apply sealant to threads of wait detection switch (gray). Then install it to rear case and tighten to the specified torque. Refer to [TF-88, "COMPONENTS"](#) .

- Use Genuine Silicone RTV or equivalent. Refer to [GI-45, "Recommended Chemical Products and Sealants"](#) .

CAUTION:

Remove old sealant and oil adhering to threads.

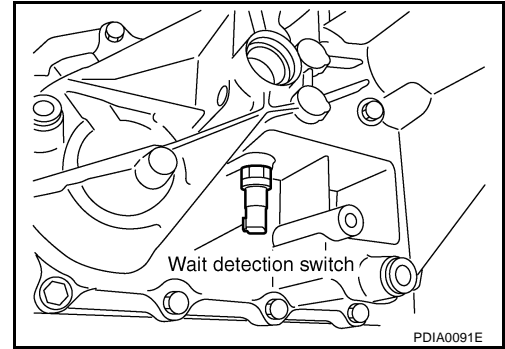

36. Apply sealant to threads of 4LO switch (gray with green paint) and ATP switch (black). Then install them to front case and tighten to the specified torque. Refer to [TF-88, "COMPONENTS"](#) .

- Use Genuine Silicone RTV or equivalent. Refer to [GI-45, "Recommended Chemical Products and Sealants"](#) .

CAUTION:

Remove old sealant and oil adhering to threads.

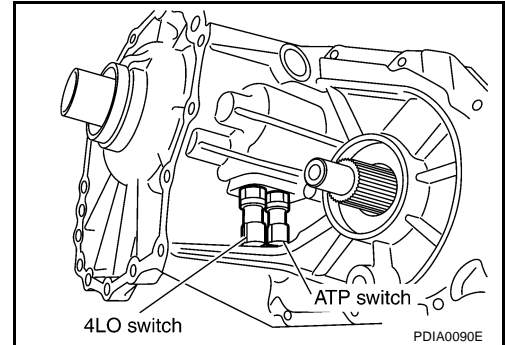

37. Install front oil seal until it is flush with end face of front case, using Tool.

Tool number : KV38100500 (—)

CAUTION:

- Do not reuse oil seal.
- Apply petroleum jelly to oil seal.

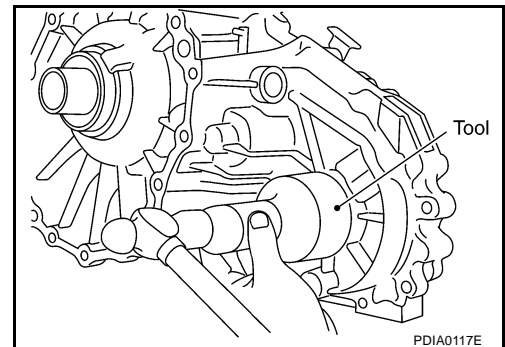

38. Align the matching mark on the front drive shaft with the mark on the companion flange, then install the companion flange.

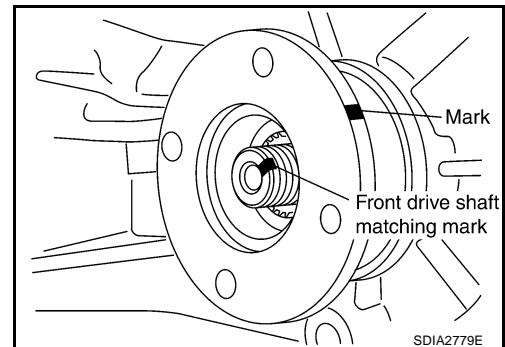

TRANSFER ASSEMBLY

39. Tighten self-lock nut to the specified torque, using Tool. Refer to [TF-88, "COMPONENTS"](#).

Tool number : KV40104000 (—)

CAUTION:

Do not reuse self-lock nut.

40. Install O-ring to transfer control device.

CAUTION:

- Do not reuse O-ring.
- Apply petroleum jelly.

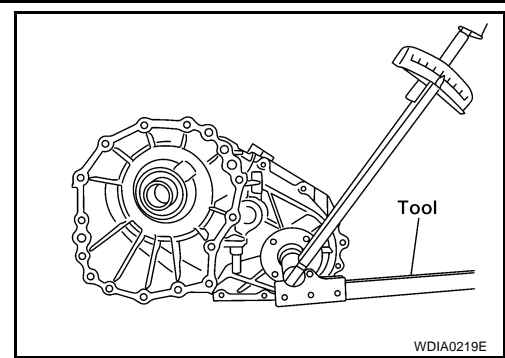

41. Install transfer control device to rear case.

- a. Turn control shift rod fully counterclockwise using flat-bladed screwdriver, and then put a mark on control shift rod.

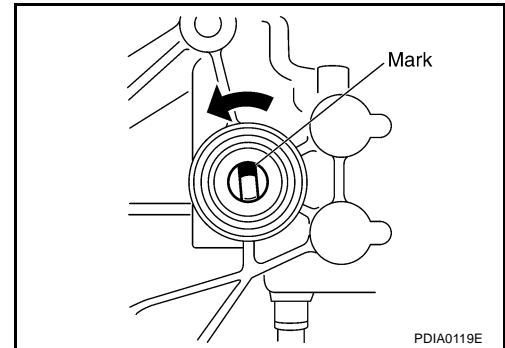

- b. Align transfer control device shaft cutout with mark on control shift rod, and install.

NOTE:

Turn transfer control device when transfer control device connection does not match.

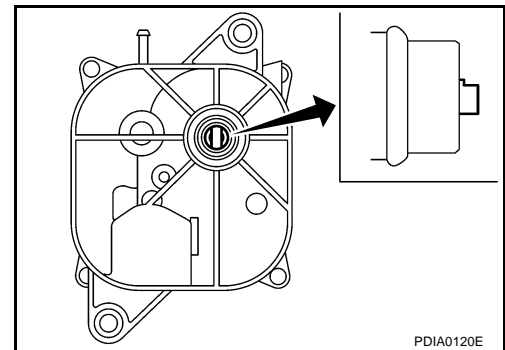

- c. Tighten bolts to the specified torque. Refer to [TF-88, "COMPONENTS"](#).

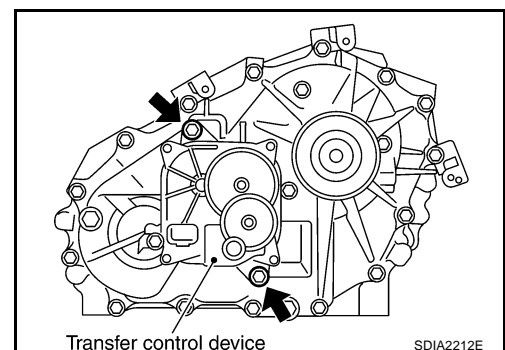

42. Install the drain plug and filler plug with new gaskets to the rear case. Tighten to the specified torque. Refer to [TF-88, "COMPONENTS"](#).

CAUTION:

Do not reuse gasket.

PLANETARY CARRIER

PDF:33113

EDS001NU

PLANETARY CARRIER

Disassembly and Assembly DISASSEMBLY

1. Remove snap ring.
2. Remove sun gear assembly from planetary carrier assembly, using suitable tool.

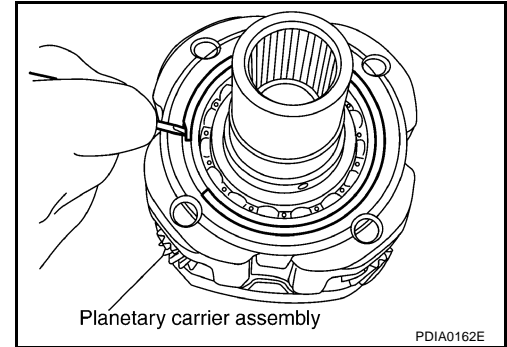

3. Remove snap ring from sun gear assembly, using suitable tool.

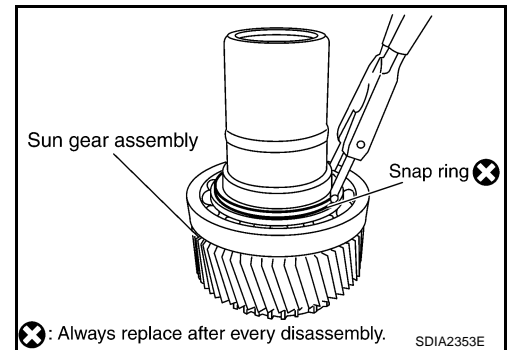

4. Remove the carrier bearing from sun gear, using Tools.

Tool number **A: ST35300000 (—)**
 B: ST30021000 (J-22912-01)

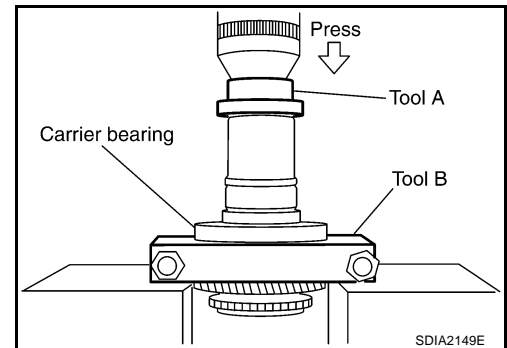

5. Remove the needle bearing from sun gear, using Tool.

Tool number **: ST33710000 (—)**

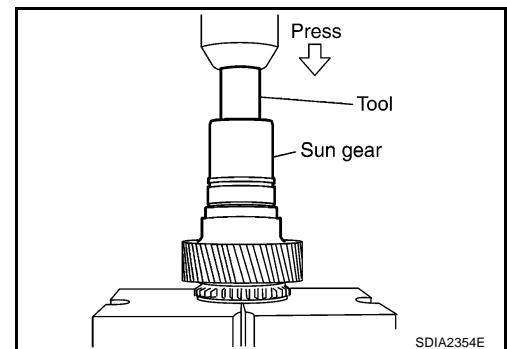

PLANETARY CARRIER

6. Remove the metal bushing from sun gear, using Tools.

- Tool number**
- A: ST33710000 (—)**
 - B: ST35325000 (—)**
 - C: ST33290001 (J-34286)**

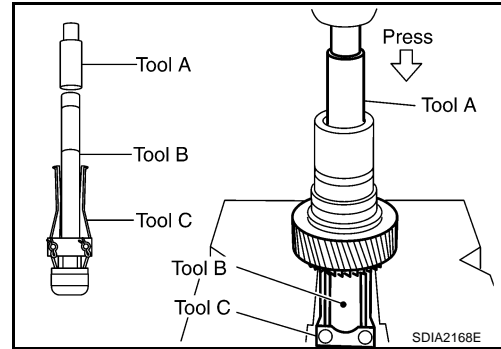

INSPECTION AFTER DISASSEMBLY

Bearing

Check the bearing for damage and rough rotation. If necessary, replace it with a new one.

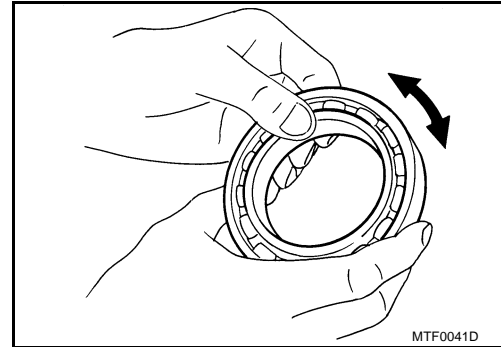

Planetary Carrier

- Measure end play of each pinion gear, and make sure the measurement is within specification shown below. If out of specification, replace planetary carrier with new one.

Pinion gear end play : 0.1 - 0.7 mm (0.004 - 0.028 in)

- Check working face of each gear, bearing and others for damage, burrs, partial wear, dents and other abnormality. If any is found, replace planetary carrier with new one.

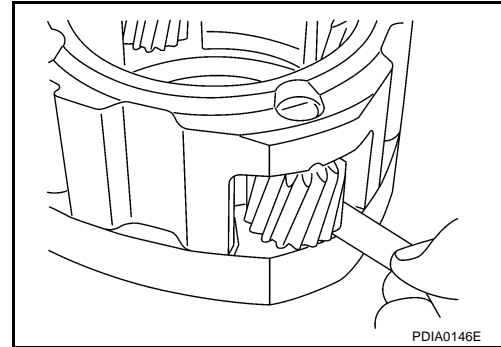

Sun Gear

Check items below. If necessary, replace them with new ones.

- If oil passage of sun gear is clogged. For this, try to pass a 3.6 mm (0.142 in) dia. wire through oil passage as shown.
- Check the sliding and contact surface of each gear and bearing for damage, burrs, partial wear, dents and other abnormality. If any is found, replace the sun gear assembly with a new one.

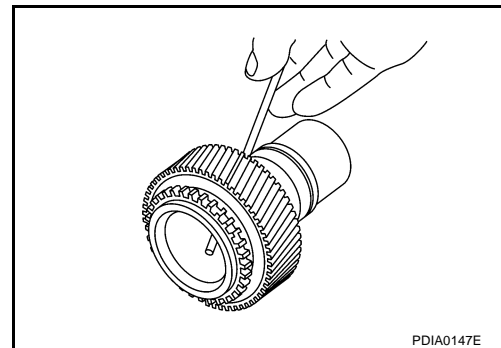

A
B
C
TF

E
F
G
H
I
J
K
L

M

PLANETARY CARRIER

Internal Gear

Check the internal gear teeth for damage, partial wear, dents or other abnormality. If any is found, replace the internal gear with a new one.

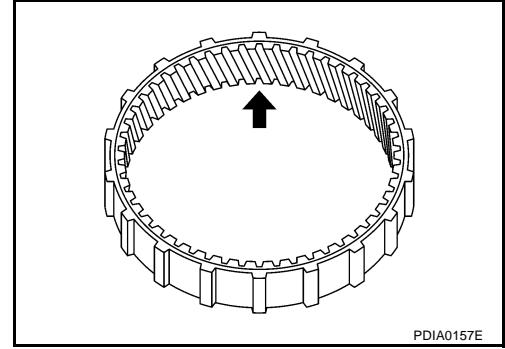

ASSEMBLY

1. Apply ATF to periphery of metal bushing, then install the metal bushing until it becomes dimension "A", using Tool.

Dimension A : 7.7 - 8.3mm (0.303 - 0.327in)

Tool number : ST35300000 (—)

CAUTION:

Do not reuse metal bushing.

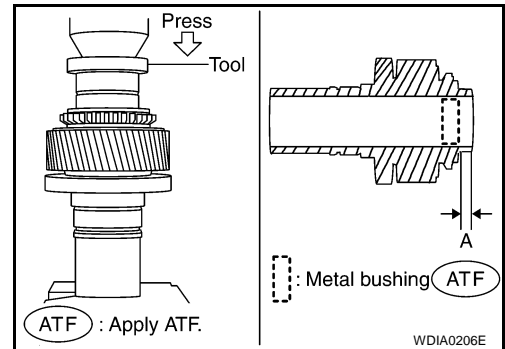

2. Apply ATF to needle bearing, then install the needle bearing until it becomes dimension "B", using Tool.

Dimension B : 62.5 - 63.1mm (2.461 - 2.484in)

Tool number : ST33220000 (—)

CAUTION:

Do not reuse needle bearing.

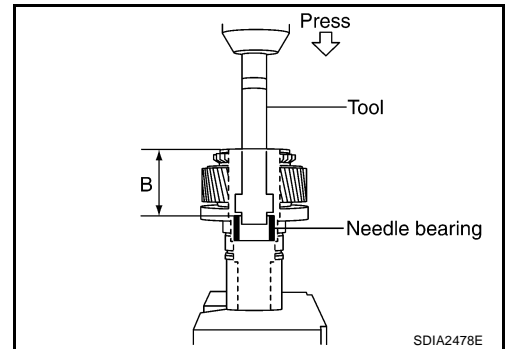

3. Install the carrier bearing to sun gear, using Tools.

Tool number A: ST30720000 (J-25405)

Tool number B: ST27863000 (—)

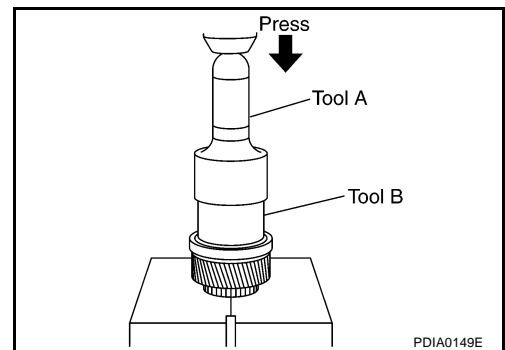

PLANETARY CARRIER

4. Install snap ring to sun gear assembly, using suitable tool.

CAUTION:
Do not reuse snap ring.

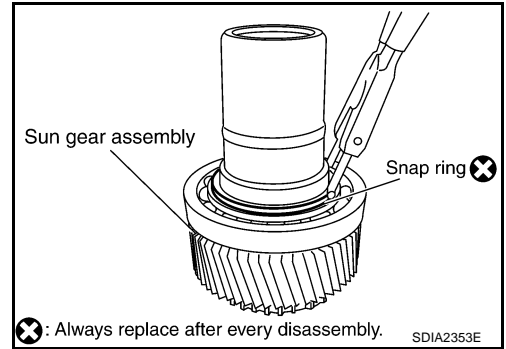

5. Install sun gear assembly to planetary carrier assembly.
6. Install snap ring to planetary carrier assembly.

CAUTION:
Do not reuse snap ring.

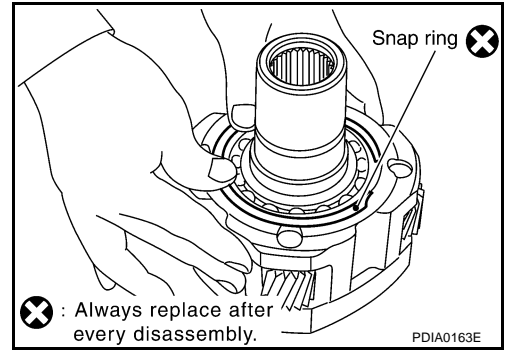

A
B
C
TF
E
F
G
H
I
J
K
L
M

FRONT DRIVE SHAFT

PF3:39100

EDS001NV

FRONT DRIVE SHAFT

Disassembly and Assembly DISASSEMBLY

1. Remove the front bearing, using Tools.

Tool number **A: ST35300000 (—)**
 B: ST30021000 (J-22912-01)

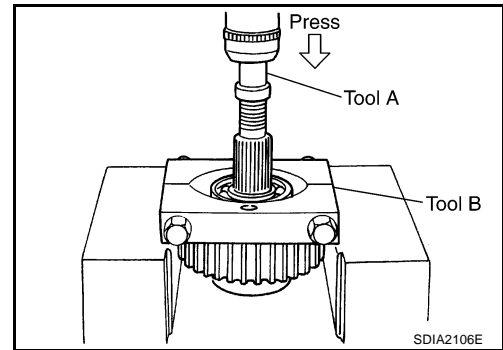

2. Remove the rear bearing, using Tools.

Tool number **A: ST33710000 (—)**
 B: ST30021000 (J-22912-01)

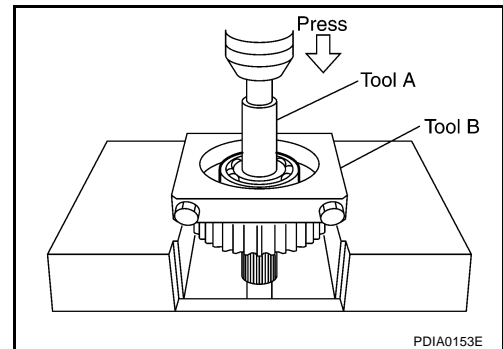

INSPECTION AFTER DISASSEMBLY

Front drive shaft

Check items below. If necessary, replace them with new ones.

- Damage, peeling, dent, uneven wear and bending of shaft.
- Excessive wear, damage and peeling of gear.

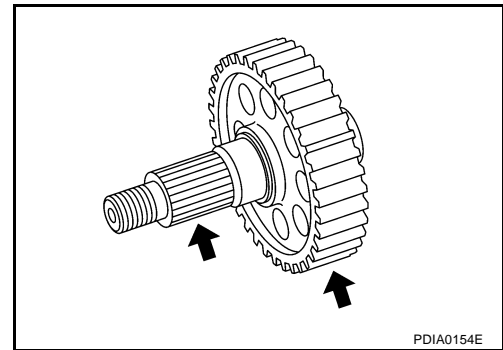

Bearing

Check the bearing for damage and rough rotation. If necessary, replace it with a new one.

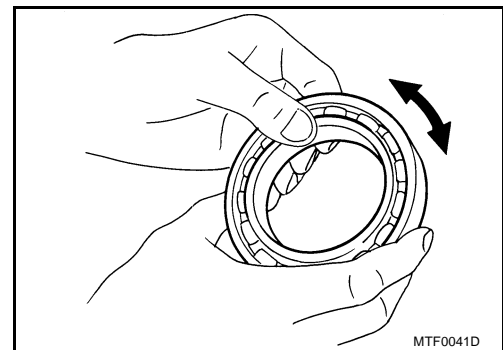

FRONT DRIVE SHAFT

ASSEMBLY

1. Install the rear bearing, using Tools.

Tool number **A: KV38100500 (—)**
 B: ST30901000 (J-26010-01)

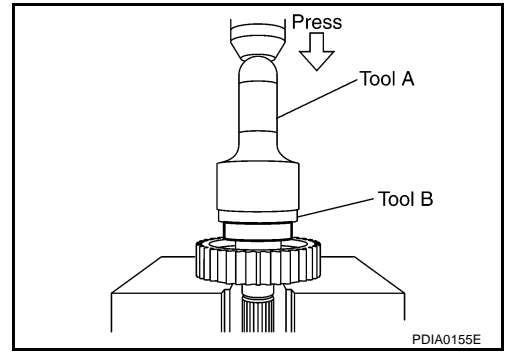

2. Install the front bearing, using Tools.

Tool number **A: KV38100500 (—)**
 B: ST30901000 (J-26010-01)

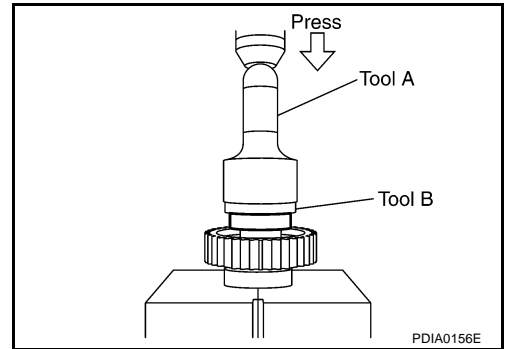

A
B
C
TF

E
F
G
H
I
J
K
L
M

SHIFT CONTROL

SHIFT CONTROL

PFP:33167

Disassembly and Assembly

EDS001NW

1. Remove snap ring and retaining pin using suitable tool. Then remove drum cam from control shift rod.

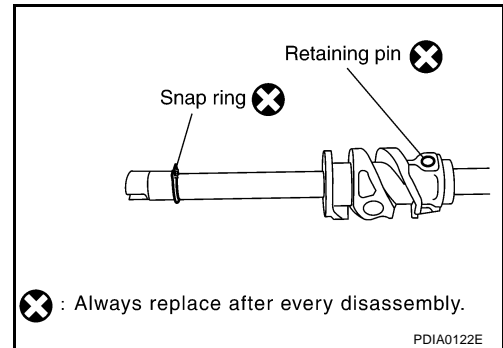

2. Remove retaining pin from L-H shift rod, using suitable tool.
3. Remove 2-4 shift bracket

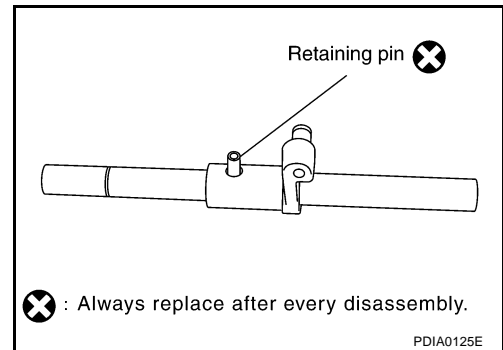

4. Remove retaining ring from 2-4 shift fork, using suitable tool.
5. Remove fork guide collar and 2-4 shift fork spring from 2-4 shift fork

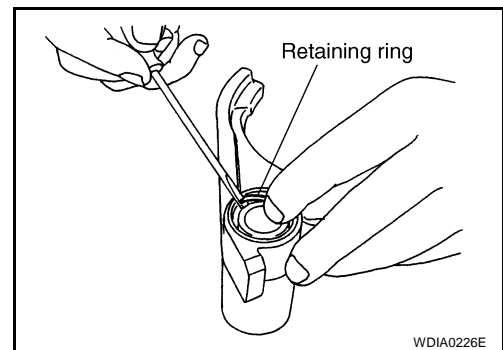

INSPECTION AFTER DISASSEMBLY

Shift fork

- Measure clearance between shift fork and sleeve. If it is out of specification, replace it with new one.

Standard value

2-4 : Less than 0.46 mm (0.018 in)

L-H : Less than 0.46 mm (0.018 in)

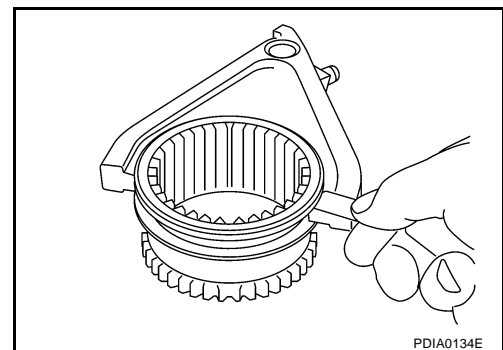

SHIFT CONTROL

Shift rod and fork components

- Check working face of shift rod and fork for wear, partial wear, abrasion, bending and other abnormality. If any is found, replace with new one.

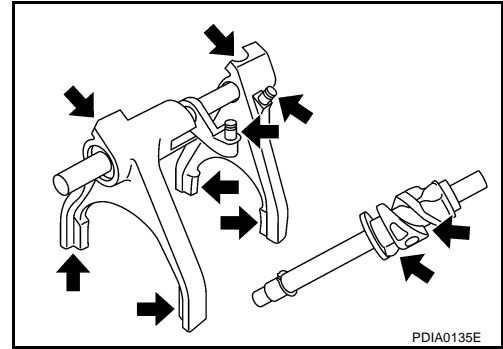

ASSEMBLY

1. Install clevis pin and shift collar to L-H shift fork after assembling them.

CAUTION:

Use caution when installing L-H shift fork, clevis pin or shift collar.

2. Install clevis pin and shift collar to 2-4 shift bracket after assembling them.

CAUTION:

Use caution when installing 2-4 shift bracket.

3. Install guide fork collar and 2-4 shift fork spring to the 2-4 shift fork, and then secure it with the retaining ring.

CAUTION:

- Do not reuse retaining ring.
- Be careful with orientation.

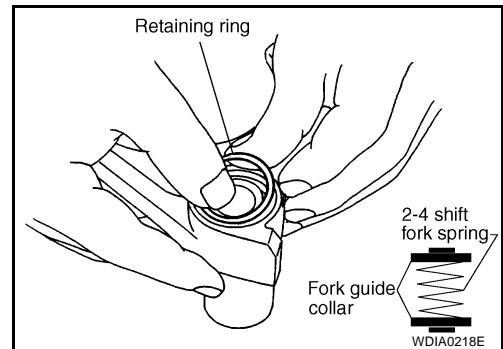

4. Install 2-4 shift bracket to the L-H shift rod.
5. Install retaining pin evenly to the L-H shift rod.

CAUTION:

Do not reuse retaining pin.

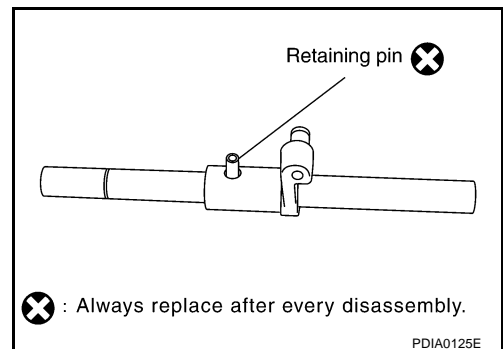

⊗ : Always replace after every disassembly.

6. Install drum cam to the control shift rod, and then secure it with retaining pin.

CAUTION:

Do not reuse retaining pin.

7. Install snap ring to the control shift rod.

CAUTION:

Do not reuse snap ring.

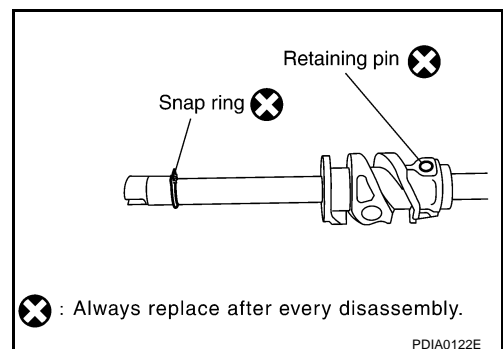

⊗ : Always replace after every disassembly.

A
B
C
TF

E

F

G

H

I

J

K

L

M

SERVICE DATA AND SPECIFICATIONS (SDS)

SERVICE DATA AND SPECIFICATIONS (SDS)

PFP:00030

General Specifications

EDS001NX

Applied model		VK56DE	
Transfer model		TX15A	
Gear ratio	High	1.000	
	Low	2.596	
Number of teeth	Planetary gear	Sun gear	57
		Internal gear	91
	Front drive sprocket		38
	Front drive shaft		38
Fluid capacity (Approx.)		ℓ (US qt, Imp qt)	2.0 (2-1/8, 1-3/4)

Pinion Gear End Play

EDS001NY

Unit: mm (in)

Item	Standard
Pinion gear end play	0.1 - 0.7 (0.004 - 0.028)

Clearance Between Shift Fork and Sleeve

EDS001NZ

Unit: mm (in)

Item	Standard
2-4 shift fork to 2-4 sleeve	Less than 0.46 mm (0.018 in)
L-H shift fork to L-H sleeve	Less than 0.46 mm (0.018 in)