

SECTION **LU**
ENGINE LUBRICATION SYSTEM

A
LU
C
D
E
F
G
H
I
J
K
L
M

CONTENTS

PRECAUTIONS	2	OIL COOLER	11
Precautions for Liquid Gasket	2	Removal and Installation	11
REMOVAL OF LIQUID GASKET SEALING	2	REMOVAL	11
LIQUID GASKET APPLICATION PROCEDURE.....	2	INSPECTION AFTER REMOVAL	11
PREPARATION	3	INSTALLATION	12
Special Service Tools	3	INSPECTION AFTER INSTALLATION	12
Commercial Service Tool	4	OIL PUMP	13
LUBRICATION SYSTEM	5	Removal and Installation	13
Lubrication Circuit	5	REMOVAL	13
System Drawing	6	INSTALLATION	13
ENGINE OIL	7	INSPECTION AFTER INSTALLATION	14
Inspection	7	Disassembly and Assembly	14
OIL LEVEL	7	DISASSEMBLY	14
OIL APPEARANCE	7	INSPECTION AFTER DISASSEMBLY	14
OIL LEAKAGE	7	ASSEMBLY	15
OIL PRESSURE CHECK	7	SERVICE DATA AND SPECIFICATIONS (SDS)	16
Changing Engine Oil	8	Standard and Limit	16
OIL FILTER	10	OIL PRESSURE	16
Removal and Installation	10	OIL PUMP	16
REMOVAL	10	REGULATOR VALVE	16
INSTALLATION	10	ENGINE OIL CAPACITY (APPROXIMATE)	16
INSPECTION AFTER INSTALLATION	10		

PRECAUTIONS

PFP:00001

PRECAUTIONS

Precautions for Liquid Gasket REMOVAL OF LIQUID GASKET SEALING

EBS00R14

- After removing the bolts and nuts, separate the mating surface and remove the old liquid gasket sealing using Tool.

Tool number : KV10111100 (J-37228)

CAUTION:

Do not damage the mating surfaces.

- Tap the seal cutter to insert it.
- In areas where the Tool is difficult to use, lightly tap to slide it.

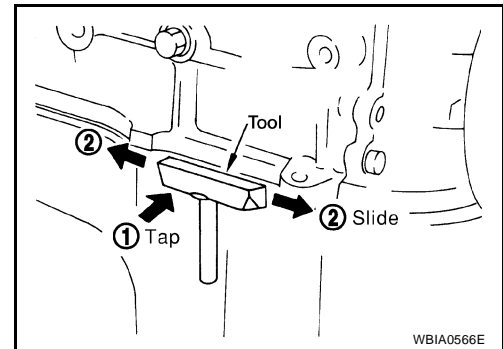

LIQUID GASKET APPLICATION PROCEDURE

1. Remove the old liquid gasket adhering to the gasket application surface and the mating surface using suitable tool.
 - Remove the liquid gasket completely from the groove of the liquid gasket application surface, bolts, and bolt holes.
2. Thoroughly clean the mating surfaces and remove adhering moisture, grease and foreign material.

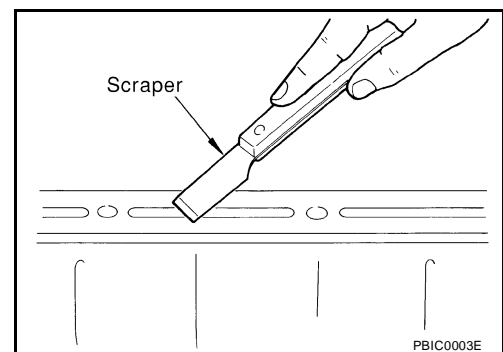

3. Attach the liquid gasket tube to the Tool.

Tool number : WS39930000 (—)

Use Genuine RTV Silicone Sealant or equivalent. Refer to GI-45, "Recommended Chemical Products and Sealants" .

4. Apply the liquid gasket without breaks to the specified location with the specified dimensions.

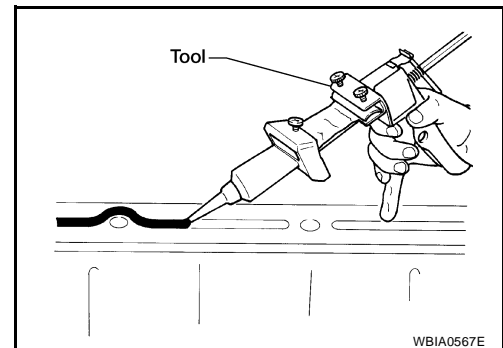

- If there is a groove for the liquid gasket application, apply the liquid gasket to the groove.
- As for the bolt holes, normally apply the liquid gasket inside the holes. If specified in the procedure, it should also be applied outside the holes.
- Within five minutes of liquid gasket application, install the mating component.
- If the liquid gasket protrudes, wipe it off immediately.
- Do not retighten after the installation.
- Wait 30 minutes or more after installation before refilling the engine with engine oil and engine coolant.

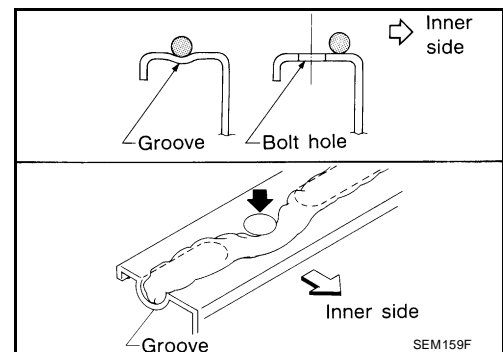

CAUTION:

If there are specific instructions in this manual, observe them.

PREPARATION

PF0:00002

PREPARATION

Special Service Tools

EBS00R15

The actual shapes of Kent-Moore tools may differ from those of special service tools illustrated here.

Tool number (Kent-Moore No.) Tool name	Description
ST25051001 (J-25695-1) Oil pressure gauge	Measuring oil pressure Maximum measuring range: 2,452 kPa (25 kg/cm² , 356 psi)
ST25052000 (J-25695-2) Hose	Adapting oil pressure gauge to cylinder block
KV10111100 (J-37228) Seal cutter	Removing steel oil pan and rear timing chain case
KV10115801 (J-38956) Oil filter wrench	Removing and installing oil filter a: 64.3 mm (2.531 in)
WS39930000 (—) Tube presser	Pressing the tube of liquid gasket

A

LU

C

D

E

F

G

H

I

J

K

L

M

PREPARATION

Commercial Service Tool

EBS00R16

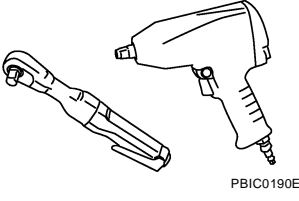
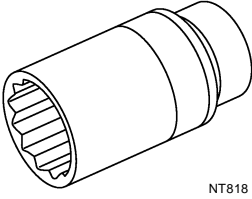
Tool name	Description
<p data-bbox="162 245 272 273">Power tool</p>  <p data-bbox="852 447 922 464">PBIC0190E</p>	<p data-bbox="1015 245 1266 273">Loosening bolts and nuts</p>
<p data-bbox="162 478 289 506">Deep socket</p>  <p data-bbox="852 699 896 716">NT818</p>	<p data-bbox="1015 478 1445 535">Removing and installing oil pressure switch Deep socket 26 mm</p>

LUBRICATION SYSTEM

LUBRICATION SYSTEM

PFP:15010

Lubrication Circuit

EBS00R17

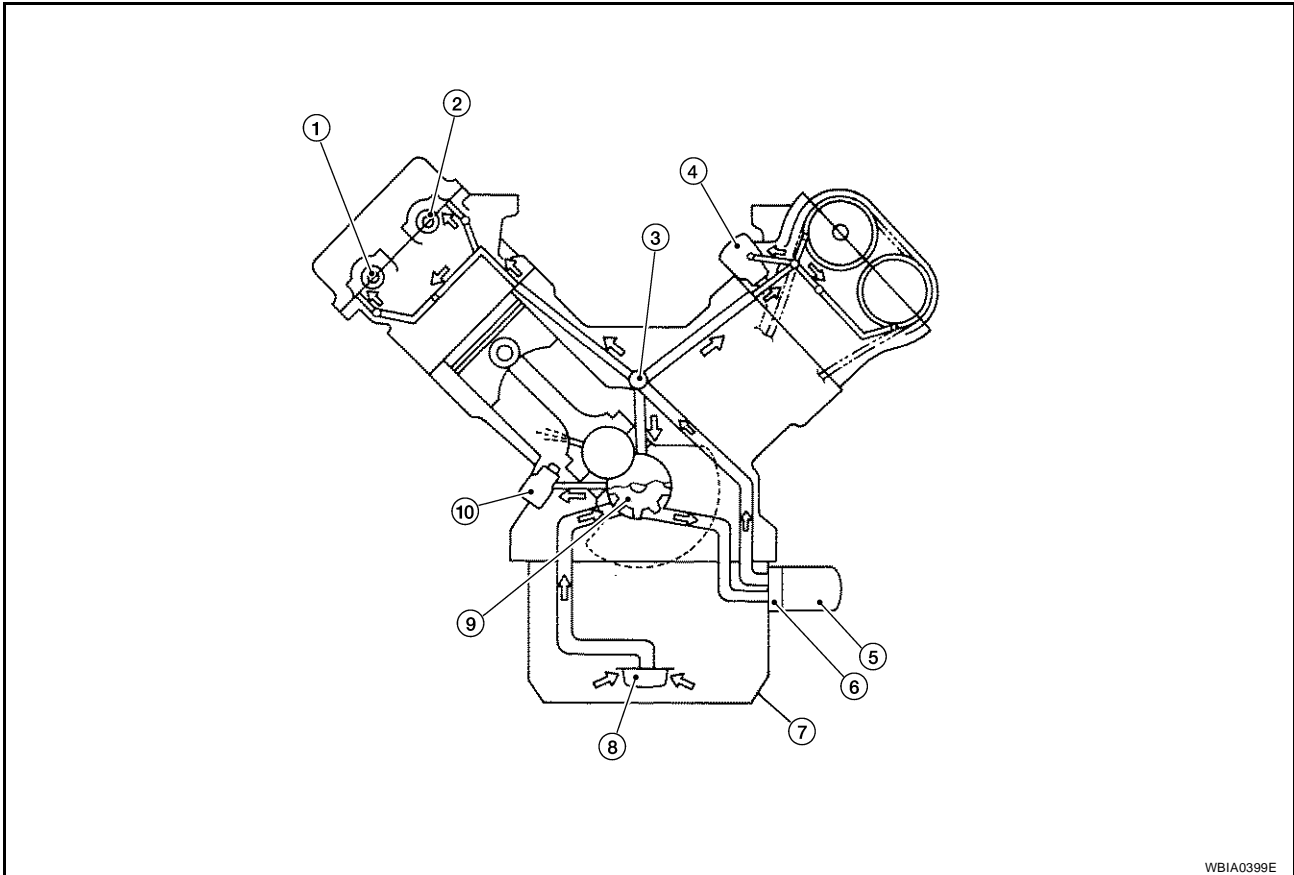

WBIA0399E

- | | | |
|----------------------------------|--------------------|--------------------|
| 1. Exhaust camshaft | 2. Intake camshaft | 3. Main oil galley |
| 4. Chain tensioner (Left bank) | 5. Oil filter | 6. Oil cooler |
| 7. Oil pan | 8. Oil strainer | 9. Oil pump |
| 10. Chain tensioner (Right bank) | | |

A

LU

C

D

E

F

G

H

I

J

K

L

M

LUBRICATION SYSTEM

System Drawing

EBS00R18

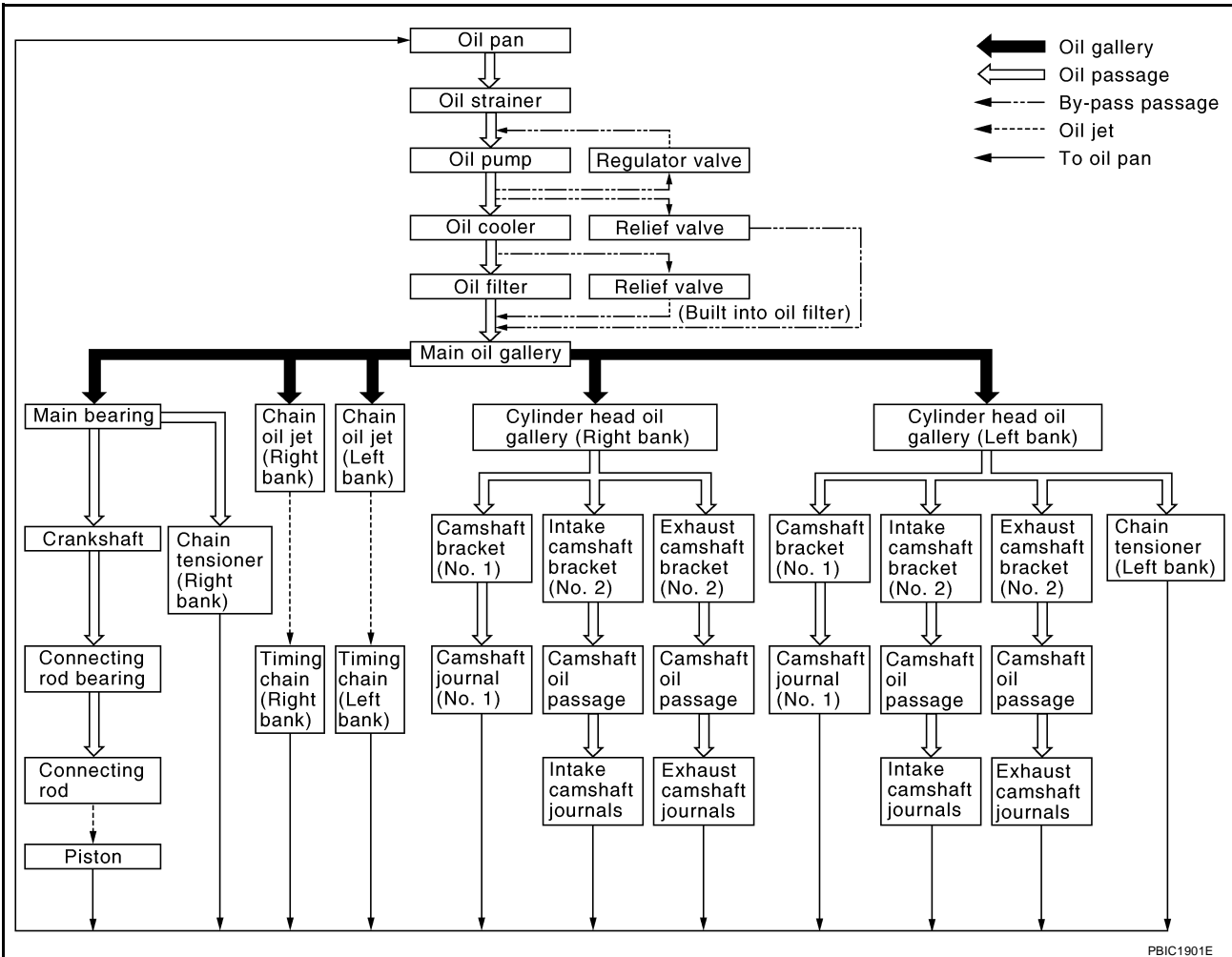

PBIC1901E

ENGINE OIL

PFP:KLA92

EBS00R19

ENGINE OIL

Inspection OIL LEVEL

- Before starting the engine make sure the vehicle is parked on a flat and level surface, then check the oil level. If the engine is already running, turn it off and allow 10 minutes before checking.
- Check that the oil level is within the low (L) and high (H) range as indicated on the dipstick.
- If the engine oil level is out of range, add oil as necessary. Refer to [MA-11, "Fluids and Lubricants"](#) .

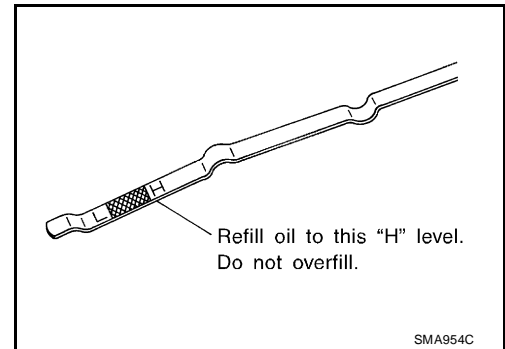

OIL APPEARANCE

- Check the engine oil for a white milky appearance or excessive contamination.
- If the engine oil is milky, it is highly probable that it is contaminated with engine coolant. Repair the broken parts.

OIL LEAKAGE

Check for oil leakage around the following areas:

- Oil pan
- Oil pan drain plug
- Oil pressure sensor
- Oil filter
- Oil cooler
- Intake valve timing control cover
- Intake valve timing control solenoid valve
- Front cover
- Mating surface between cylinder block and cylinder head
- Mating surface between cylinder head and rocker cover
- Crankshaft oil seal (front and rear)

OIL PRESSURE CHECK

WARNING:

- **Be careful not to burn yourself, as engine oil may be hot.**
 - **Put the selector lever in the Park "P" position.**
1. Check the engine oil level. Refer to [LU-7, "OIL LEVEL"](#) .
 2. Remove engine front undercover using power tool.
 3. Disconnect the oil pressure sensor harness connector.
 4. Remove the oil pressure sensor.

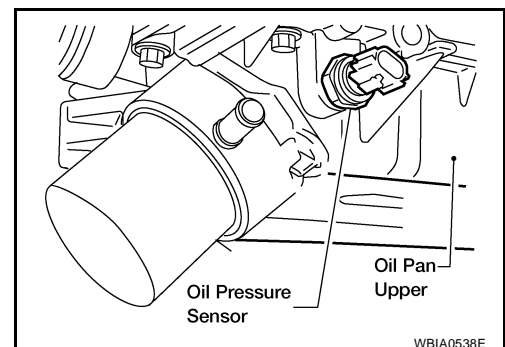

ENGINE OIL

5. Install Tools.

Tool number : ST25051001 (J-25695-1)
 : ST25052000 (J-25695-2)

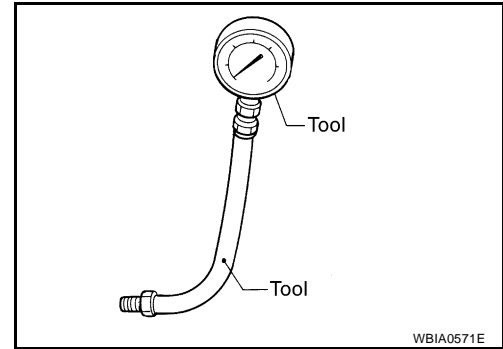

6. Start the engine and warm it up to normal operating temperature.
 7. Check the engine oil pressure with engine running under no-load.

Engine oil pressure [Engine oil temperature at 80°C (175°F)]

Unit: kPa (kg/cm², psi)

Engine Speed	Approximate Discharge Pressure
Idle speed	More than 98 (1.0, 14)
2,000 rpm	More than 294 (3.0, 43)

CAUTION:

If the difference is extreme, check the oil passages and oil pump for leaks and blockages.

8. After the inspections, install oil pressure sensor as follows:
- Remove old liquid gasket adhering to oil pressure sensor and engine.
 - Apply liquid gasket and tighten oil pressure sensor to the specification.

Use Genuine RTV Silicone Sealant or equivalent. Refer to [GI-45, "RECOMMENDED CHEMICAL PRODUCTS AND SEALANTS"](#) .

Oil pressure sensor torque : 14.7 N·m (1.5 kg·m, 11 ft·lb)

- After warming up engine, make sure there is no leakage of engine oil with engine running.

Changing Engine Oil

EBS00RIA

WARNING:

- Be careful not to burn yourself, as the engine oil is hot.
- Prolonged and repeated contact with used engine oil may cause skin cancer. Try to avoid direct skin contact with used engine oil. If skin contact is made, wash thoroughly with soap or hand cleaner as soon as possible.

- Remove engine front undercover using power tool.
- Warm up engine, and check for oil leakage from engine components. Refer to [LU-7, "OIL LEAKAGE"](#) .
- Stop engine and wait for 10 minutes.
- Loosen oil filler cap, then remove drain plug.
- Drain engine oil.
- Install drain plug with new washer.

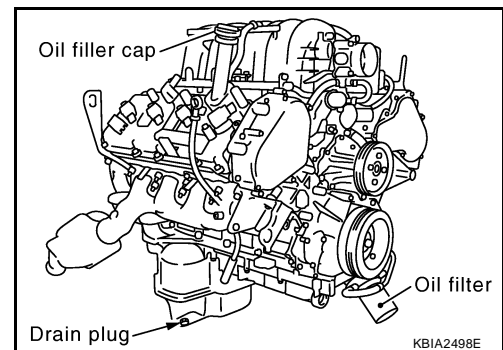

CAUTION:

- Be sure to clean drain plug and install with new washer.

Oil pan drain plug : 34.3 N·m (3.5 kg·m, 25 ft·lb)

- Refill with new engine oil. Refer to [MA-11, "Fluids and Lubricants"](#) .

ENGINE OIL

Engine oil capacity (Approximate):

		Unit: ℓ (US qt, Imp qt)
Drain and refill	With oil filter change	6.2 (6 1/2, 5-1/2)
	Without oil filter change	5.9 (6-1/4, 5-1/4)
Dry engine (engine overhaul)		7.6 (8, 6-3/4)

CAUTION:

- The refill capacity depends on the engine oil temperature and drain time. Use these specifications for reference only.
 - Always use the oil level gauge to determine when the proper amount of engine oil is in the engine.
8. Warm up engine and check area around drain plug and oil filter for oil leakage.
 9. Stop engine and wait for 10 minutes.
 10. Check engine oil level. Refer to [LU-7, "OIL LEVEL"](#) .

A
LU
C
D
E
F
G
H
I
J
K
L
M

OIL FILTER

PF:15208

EBS00R1B

OIL FILTER

Removal and Installation

REMOVAL

1. Remove the engine front undercover using power tool.
2. Remove the oil filter using Tool.

Tool number : KV10115801 (J-38956)

CAUTION:

- The oil filter is provided with a relief valve.
Use Genuine NISSAN oil filter or equivalent.
- Be careful not to get burned when the engine and engine oil are hot.
- When removing, prepare a shop cloth to absorb any engine oil leakage or spillage.
- Do not allow engine oil to adhere to the drive belts.
- Completely wipe off any engine oil that adheres to the engine and the vehicle.

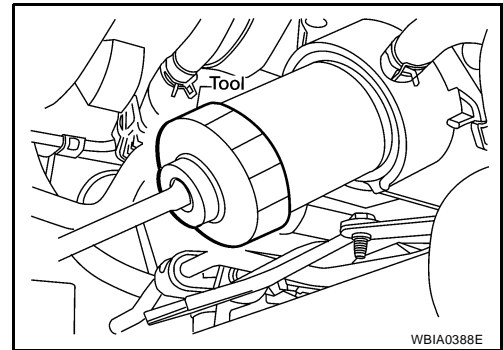

INSTALLATION

1. Remove foreign materials adhering to the oil filter installation surface.
2. Apply engine oil to the oil seal circumference of the new oil filter.

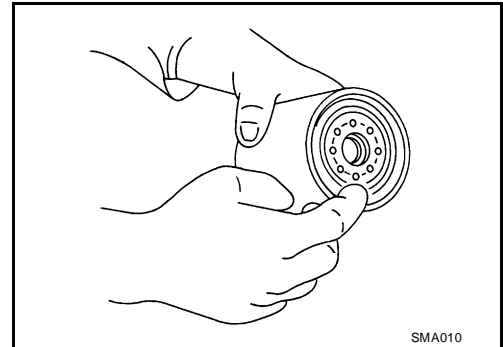

3. Screw the oil filter manually until it touches the installation surface, then tighten it by 2/3 turn. Or tighten to specification.

Oil filter : 17.7 N-m (1.8 kg-m, 13 ft-lb)

4. Inspect the engine for oil leakage. Refer to [LU-10, "INSPECTION AFTER INSTALLATION"](#).
5. Install the engine front undercover using power tool.

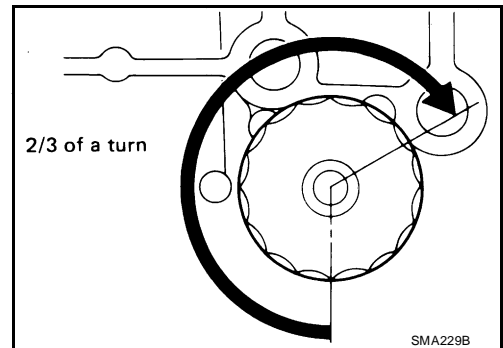

INSPECTION AFTER INSTALLATION

1. Check the engine oil level. Refer to [LU-7, "OIL LEVEL"](#).
2. Start the engine and check for engine oil leakage.
3. Stop the engine and wait for 10 minutes.
4. Check the engine oil level and add engine oil as required.

OIL COOLER

PFP:21305

OIL COOLER

Removal and Installation

EBS00RIC

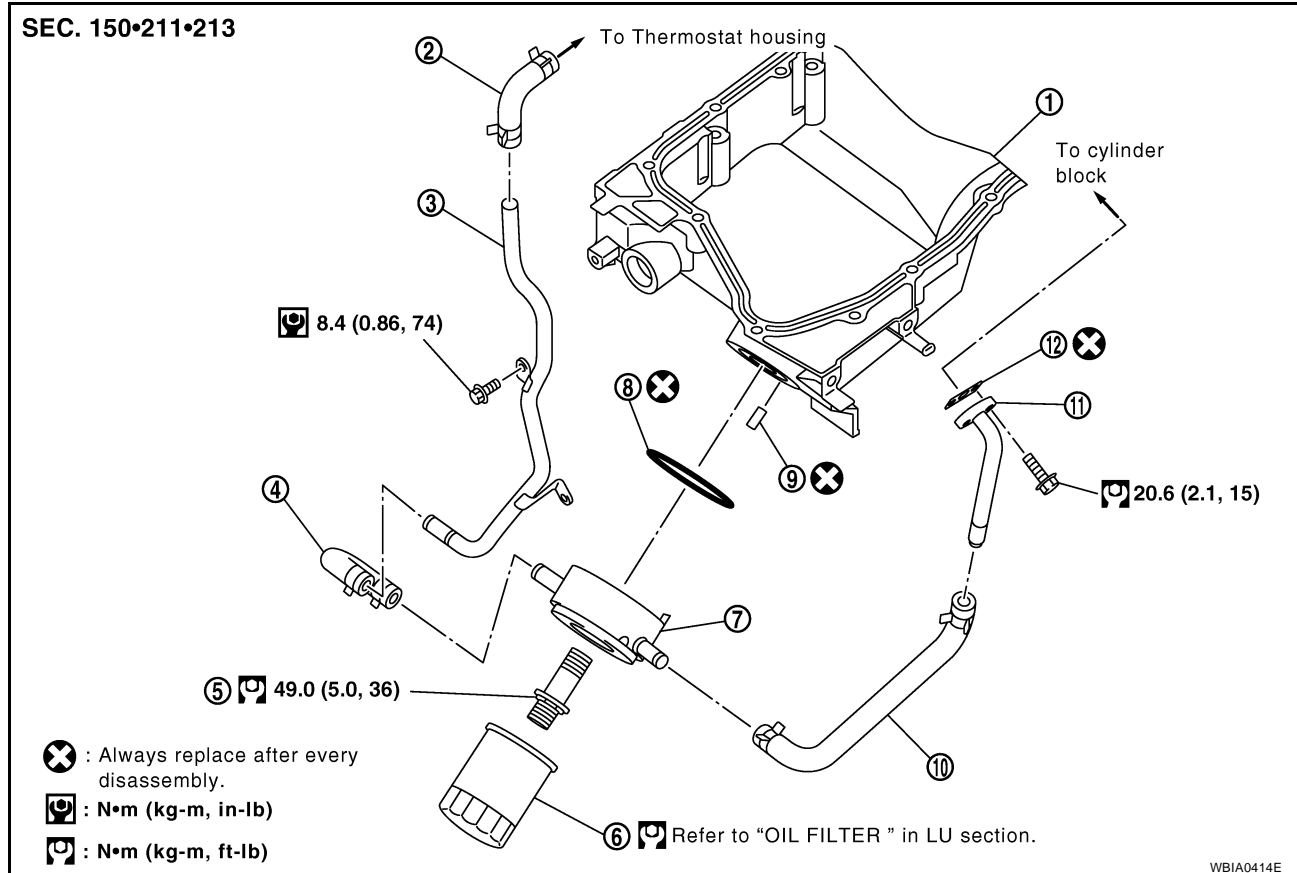

- | | | |
|----------------|--------------------|-----------------|
| 1. Oil pan | 2. Water hose | 3. Water pipe |
| 4. Water hose | 5. Connector bolt | 6. Oil filter |
| 7. Oil cooler | 8. O-ring | 9. Relief valve |
| 10. Water hose | 11. Connector pipe | 12. Gasket |

WARNING:

Be careful not to burn yourself, as the engine oil and engine coolant are hot.

REMOVAL

1. Remove engine front undercover using power tool.
2. Disconnect water hoses, pinching hoses near oil cooler to prevent engine coolant from spilling.

CAUTION:

Do not spill engine coolant on the drive belt.

3. Remove oil filter. Refer to [LU-10, "Removal and Installation"](#).

CAUTION:

Do not spill engine oil on the drive belts.

4. Remove connector bolt, and remove oil cooler.

INSPECTION AFTER REMOVAL

Oil Cooler

Check oil cooler for cracks. Check oil cooler for clogging by blowing compressed air through engine coolant inlet. If necessary, replace oil cooler assembly.

Relief Valve

Inspect relief valve for movement, cracks and breaks by pushing the ball. If replacement is necessary, remove the valve by prying it out using a suitable tool. Install a new valve in place by tapping it.

OIL COOLER

INSTALLATION

Installation is in the reverse order of removal, paying attention to the following:

- Confirm that no foreign objects are adhering to the sealing surfaces of the oil cooler or oil pan.
- Tighten the connecting bolt after aligning the stopper on the oil pan side with protrusion of the oil cooler.

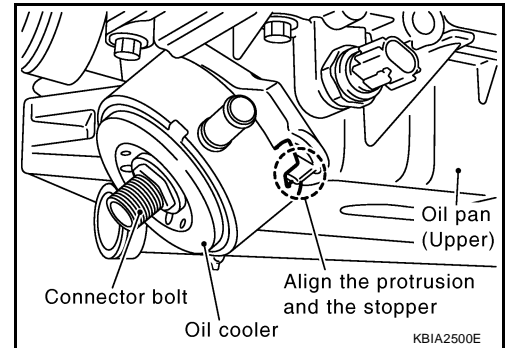

INSPECTION AFTER INSTALLATION

1. Check levels and add engine oil and engine coolant. Refer to [LU-7, "OIL LEVEL"](#) and [CO-10, "LEVEL CHECK"](#).
2. Start the engine, and check for leaks of engine oil and engine coolant.
3. Stop the engine and wait for 10 minutes.
4. Check engine oil level and engine coolant level again.

OIL PUMP

OIL PUMP

PFP:15010

Removal and Installation

EBS00RID

SEC. 135

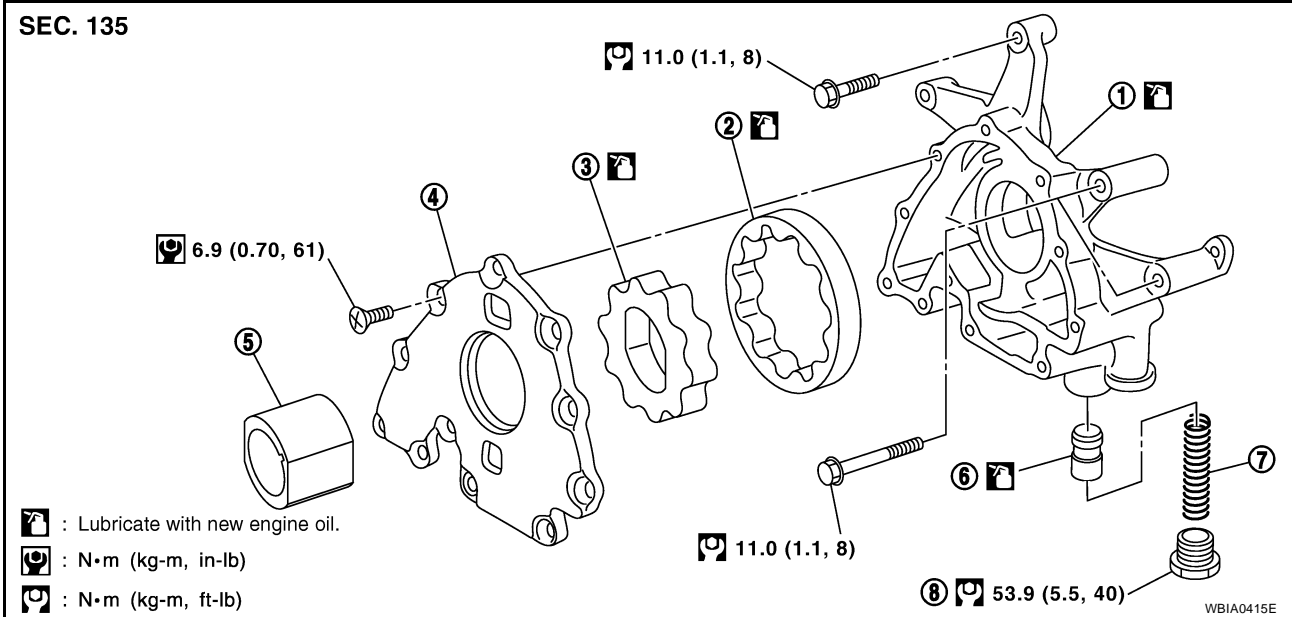

- | | | |
|---------------------|--------------------------|--------------------|
| 1. Oil pump body | 2. Outer rotor | 3. Inner rotor |
| 4. Oil pump cover | 5. Oil pump drive spacer | 6. Regulator valve |
| 7. Regulator spring | 8. Regulator plug | |

REMOVAL

1. Remove front cover. Refer to [EM-37, "TIMING CHAIN"](#) .
2. Remove the oil pump drive spacer.
3. Remove the oil pump.

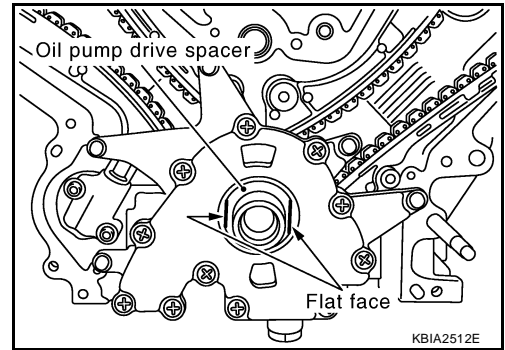

INSTALLATION

Installation is in the reverse order of removal, paying attention of the following:

- When inserting the oil pump drive spacer, align the crankshaft key and the flat face of the inner rotor.
- If they are not aligned, rotate the oil pump inner rotor by hand.
- Make sure that the each part is aligned and tap lightly until it reaches the end.

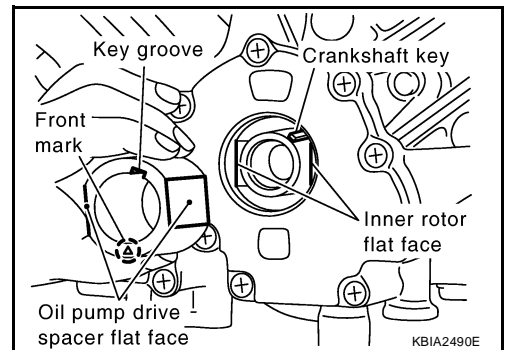

OIL PUMP

INSPECTION AFTER INSTALLATION

- Start the engine, and check for leaks of engine oil.
- Stop engine and wait 10 minutes.
- Check level and add engine oil as required. Refer to [LU-7, "ENGINE OIL"](#) .

Disassembly and Assembly DISASSEMBLY

EBS00RIE

1. Remove oil pump cover.
2. Remove inner rotor and outer rotor from oil pump body.
3. Remove the regulator plug, regulator spring and regulator valve.

INSPECTION AFTER DISASSEMBLY

Clearance of Oil Pump Parts

- Measure radial clearance using a suitable tool.

Body to outer rotor (position 1)

: 0.114 - 0.200 mm (0.0045 - 0.0079 in)

Inner rotor to outer rotor tip (position 2)

: Below 0.180 mm (0.0071 in)

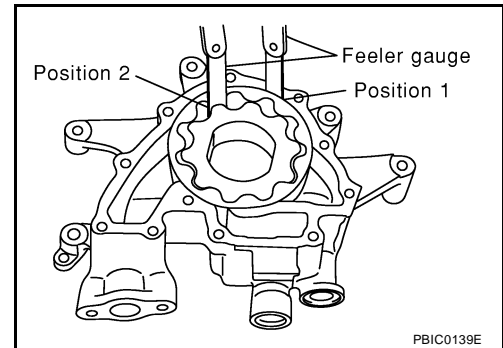

- Measure side clearance using suitable tools.

Body to inner rotor (position 3)

: 0.030 - 0.070 mm (0.0012 - 0.0028 in)

Body to outer rotor (position 4)

: 0.030 - 0.090 mm (0.0012 - 0.0035 in)

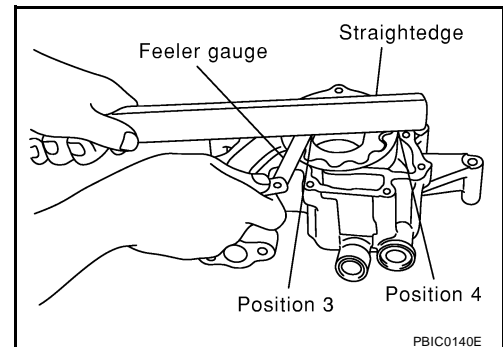

- Calculate the clearance between inner rotor and oil pump body as follows.

1. Measure the outer diameter of protruded portion of inner rotor (position 5) using suitable tool.

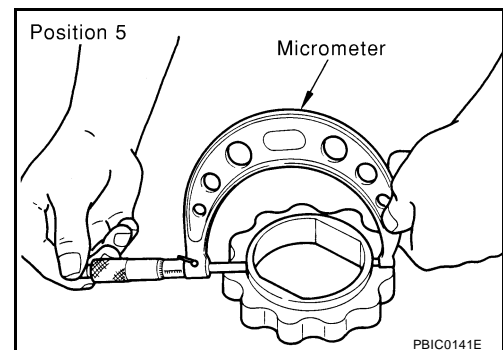

OIL PUMP

2. Measure the inner diameter of oil pump body to brazed portion (position 6) using suitable tool.

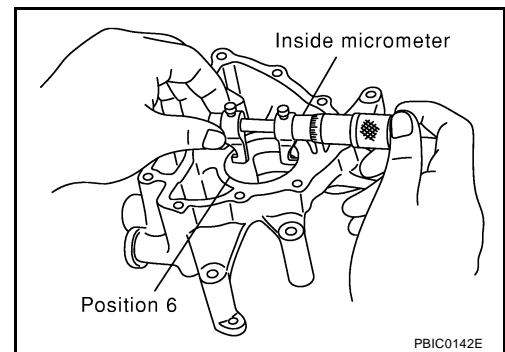

3. Calculate the clearance using the following formula.

- (Clearance) = (Inner diameter of oil pump body) - (Outer diameter of inner rotor)

Inner rotor to brazed portion of housing clearance
: 0.045 - 0.091 mm (0.0018 - 0.0036 in)

Regulator Valve Clearance

Check regulator valve to oil pump cover clearance using the following formula.

- (Clearance) = D1 (Valve hole diameter) - D2 (Outer Diameter of valve)

Regulator valve to oil pump cover
: 0.040 - 0.097 mm (0.0016 - 0.0038 in)

CAUTION:

- Coat regulator valve with engine oil.
- Check that it falls smoothly into the regulator valve hole by its own weight.

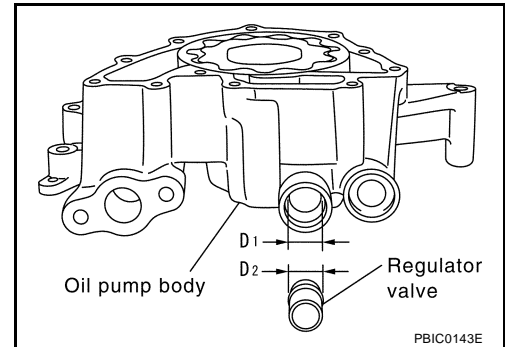

ASSEMBLY

Installation is in the reverse order of removal.

NOTE:

Install the inner rotor and outer rotor with the punched marks on the oil pump cover side.

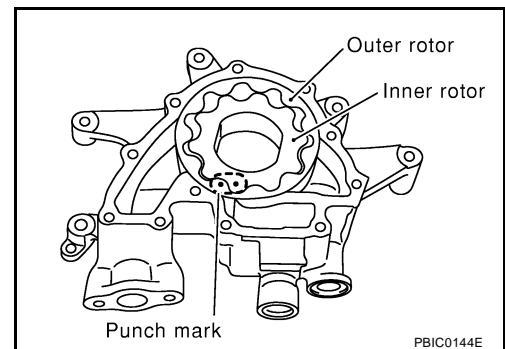

SERVICE DATA AND SPECIFICATIONS (SDS)

SERVICE DATA AND SPECIFICATIONS (SDS)

PFP:00030

Standard and Limit OIL PRESSURE

EBS00R1F

Unit: kPa (kg/cm², psi)

Engine speed rpm	Approximate discharge oil pressure
Idle speed 2,000	More than 98 (1.0, 14) More than 294 (3.0, 43)

OIL PUMP

Unit: mm (in)

Body to outer rotor radial clearance	0.114 - 0.200 (0.0045 - 0.0079)
Inner rotor to outer rotor tip clearance	Below 0.180 (0.0071)
Body to inner rotor side clearance	0.030 - 0.070 (0.0012 - 0.0028)
Body to outer rotor side clearance	0.030 - 0.090 (0.0012 - 0.0035)
Inner rotor to brazed portion of housing clearance	0.045 - 0.091 (0.0018 - 0.0036)

REGULATOR VALVE

Unit: mm (in)

Regulator valve to oil pump cover clearance	0.040 - 0.097 (0.0016 - 0.0038)
---	---------------------------------

ENGINE OIL CAPACITY (APPROXIMATE)

Unit: ℓ (US qt, Imp qt)

Drain and refill	With oil filter change	6.2 (6 1/2, 5-1/2)
	Without oil filter change	5.9 (6-1/4, 5-1/4)
Dry engine (engine overhaul)		7.6 (8, 6-3/4)