

SECTION **RSU**  
REAR SUSPENSION

A  
B  
C  
D

RSU

CONTENTS

<b>PRECAUTIONS</b> .....	2	<b>SHOCK ABSORBER</b> .....	7	F
Precautions .....	2	Removal and Installation .....	7	
<b>PREPARATION</b> .....	3	REMOVAL .....	7	G
Commercial Service Tools .....	3	INSPECTION AFTER REMOVAL .....	7	
<b>NOISE VIBRATION AND HARSHNESS (NVH)</b>		INSTALLATION .....	7	
<b>TROUBLESHOOTING</b> .....	4	<b>LEAF SPRING</b> .....	8	H
NVH Troubleshooting Chart .....	4	Removal and Installation .....	8	
<b>REAR SUSPENSION ASSEMBLY</b> .....	5	REMOVAL .....	9	I
Components .....	5	INSPECTION AFTER REMOVAL .....	9	
On-Vehicle Inspection and Service .....	6	INSTALLATION .....	10	J
		<b>SERVICE DATA AND SPECIFICATIONS (SDS)</b> .....	11	K
		General Specifications (Rear) .....	11	
		Wheelarch Height (Unladen*1) .....	11	L

M

# PRECAUTIONS

---

## PRECAUTIONS

PF0:00001

### Precautions

EES001CT

- When installing rubber parts, final tightening must be carried out under unladen condition\* with tires on ground.  
\* Fuel, radiator coolant, and engine oil are full. Spare tire, jack, hand tools, and mats are in their designated positions.

# PREPARATION

## PREPARATION

PFP:00002

### Commercial Service Tools

EES001CU

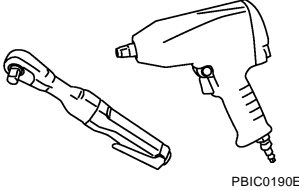
Tool name	Description
Power tool  PBIC0190E	Removing nuts and bolts

A  
B  
C  
D

**RSU**

F  
G  
H  
I  
J  
K  
L  
M

# NOISE VIBRATION AND HARSHNESS (NVH) TROUBLESHOOTING

## NOISE VIBRATION AND HARSHNESS (NVH) TROUBLESHOOTING

PF:54000

### NVH Troubleshooting Chart

EES001CV

Use the chart below to help you find the cause of the symptom. If necessary, repair or replace the parts.

Reference page		<a href="#">RSU-5</a>	<a href="#">RSU-7</a>	<a href="#">RSU-5</a>	<a href="#">RSU-5</a>	<a href="#">RSU-8</a>	<a href="#">RSU-5</a>	<a href="#">PR-3, "NVH Troubleshooting Chart"</a>	<a href="#">RFD-8, "NVH Troubleshooting Chart"</a>	<a href="#">RAX-4, "NVH Troubleshooting Chart"</a>	<a href="#">WT-5, "NVH Troubleshooting Chart"</a>	<a href="#">WT-5, "NVH Troubleshooting Chart"</a>	<a href="#">BR-5, "NVH Troubleshooting Chart"</a>	<a href="#">PS-5, "NVH Troubleshooting Chart"</a>
Possible cause and SUSPECTED PARTS		Improper installation, looseness	Shock absorber deformation, damage or deflection	Bushing or mounting deterioration	Parts interference	Spring fatigue	Suspension looseness	PROPELLER SHAFT	REAR FINAL DRIVE	AXLE	TIRES	ROAD WHEEL	BRAKES	STEERING
Symptoms	Noise	x	x	x	x	x	x	x	x	x	x	x	x	x
	Shake	x	x	x	x		x	x		x	x	x	x	x
	Vibration	x	x	x	x	x		x		x	x			x
	Shimmy	x	x	x	x					x	x	x	x	x
	Shudder	x	x	x						x	x	x	x	x
	Poor quality ride or handling	x	x	x	x	x	x			x	x	x		

x: Applicable

# REAR SUSPENSION ASSEMBLY

## REAR SUSPENSION ASSEMBLY

PFP:55020

### Components

EES001CW

#### SEC. 431

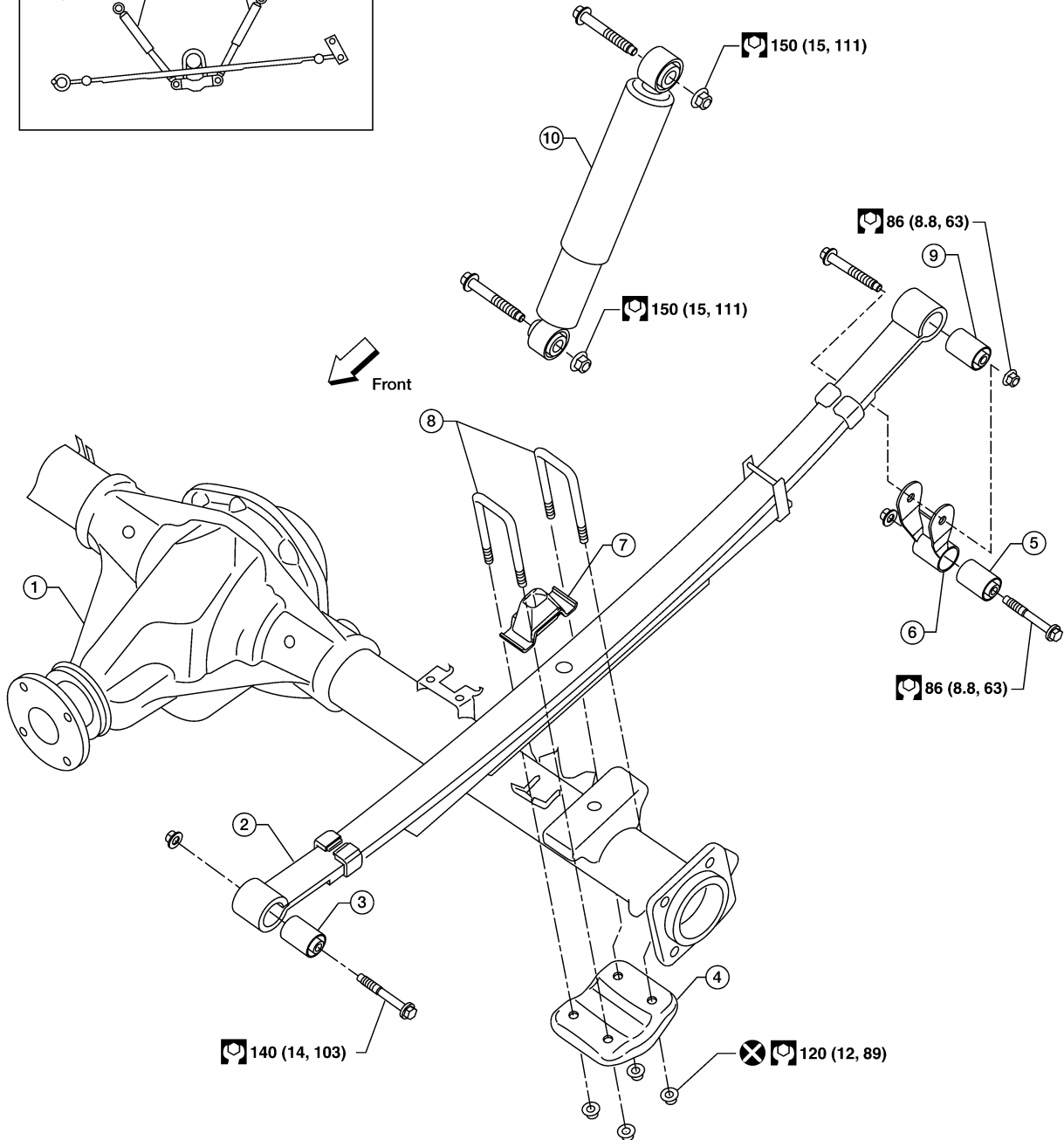
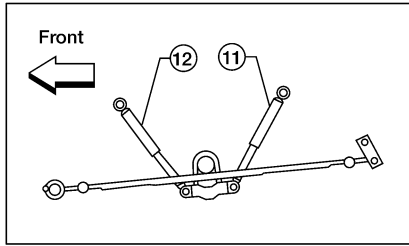

: N-m (kg-m, ft-lb)

: Always replace after every disassembly.

- |                     |                                |                                 |
|---------------------|--------------------------------|---------------------------------|
| 1. Rear final drive | 2. Rear leaf spring            | 3. Rear spring bushing (front)  |
| 4. Rear spring pad  | 5. Rear spring shackle bushing | 6. Rear spring shackle          |
| 7. Bumper           | 8. Rear spring clip U-bolts    | 9. Rear spring bushing (rear)   |
| 10. Shock absorber  | 11. Shock absorber (left side) | 12. Shock absorber (right side) |

LEIA0102E

A  
B  
C  
D  
RSU  
F  
G  
H  
I  
J  
K  
L  
M

# REAR SUSPENSION ASSEMBLY

## CAUTION:

When installing the components with rubber bushings, the final tightening of the nuts and bolts must be done with the vehicle in an unladen condition (the fuel, engine coolant, and engine oil full; the spare tire, jack, hand tools and mats in their designated positions) with the tires on the ground.

## On-Vehicle Inspection and Service

EES001CX

- Check the rear suspension parts for any excessive play, cracks, wear, and other damage.
- Shake each rear wheel to check for any excessive play as shown.
- Tighten all of the nuts and bolts to the specified torque. Refer to [RSU-5, "Components"](#).

## CAUTION:

When installing the components with rubber bushings, the final tightening of the nuts and bolts must be done with the vehicle in an unladen condition (the fuel, engine coolant, and engine oil full; the spare tire, jack, hand tools and mats in their designated positions) with the tires on the ground.

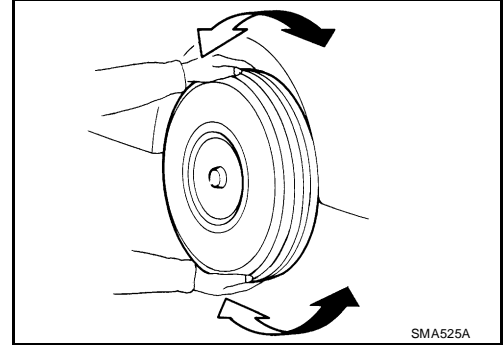

- Check the shock absorbers for oil leaks, deformation, and other damage.
- Check the shock absorber bushings for excessive wear and other damage.

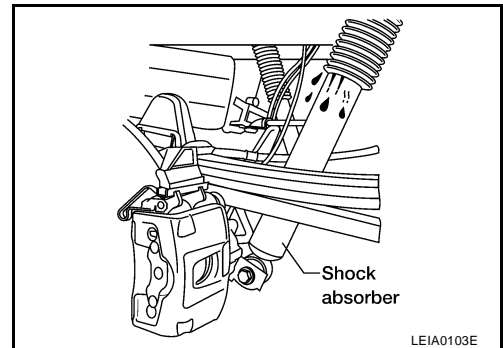

# SHOCK ABSORBER

## SHOCK ABSORBER

PFP:56210

### Removal and Installation

EES001CY

1. Support the rear final drive and suspension assembly using a suitable jack.
2. Remove the shock absorber upper and lower nuts and bolts using power tool.
3. Remove the shock absorber.

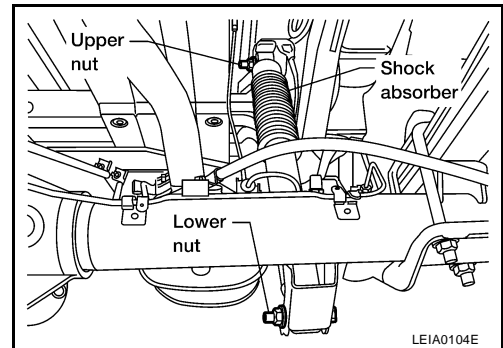

### INSPECTION AFTER REMOVAL

Inspect the shock absorber for any oil leaks, cracks, or deformations. Replace the shock absorber as necessary.

### INSTALLATION

Installation is in the reverse order of removal.

**Shock absorber upper and lower nuts** : Refer to [RSU-5, "Components"](#) .

A  
B  
C  
D  
RSU  
F  
G  
H  
I  
J  
K  
L  
M

# LEAF SPRING

PF:55020

EES001CZ

## LEAF SPRING

### Removal and Installation

#### SEC. 431

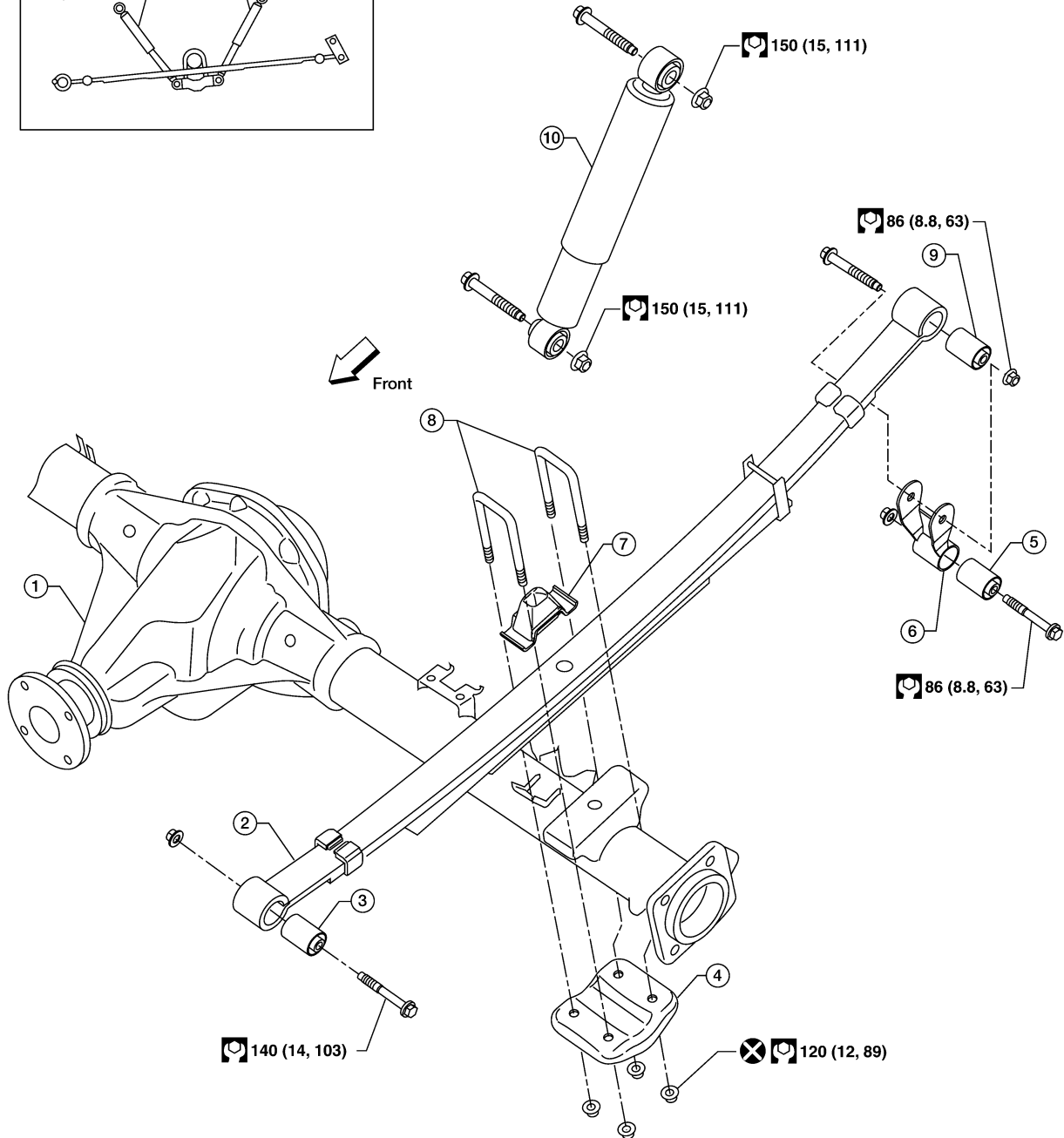
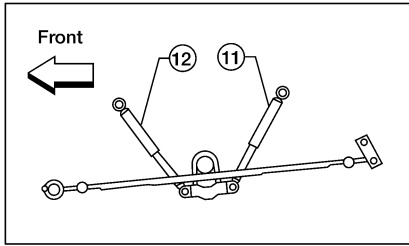

: N·m (kg·m, ft·lb)

: Always replace after every disassembly.

- |                     |                                |                                 |
|---------------------|--------------------------------|---------------------------------|
| 1. Rear final drive | 2. Rear leaf spring            | 3. Rear spring bushing (front)  |
| 4. Rear spring pad  | 5. Rear spring shackle bushing | 6. Rear spring shackle          |
| 7. Bumper           | 8. Rear spring clip U-bolts    | 9. Rear spring bushing (rear)   |
| 10. Shock absorber  | 11. Shock absorber (left side) | 12. Shock absorber (right side) |

LEIA0102E



# LEAF SPRING

## CAUTION:

When installing the components with rubber bushings, the final nut tightening must be carried out under unladen\* conditions with the tires on level ground.

\* (Fuel, radiator coolant and engine oil full. Spare tire, jack, hand tools and mats in designated positions.)

## REMOVAL

1. Support the rear final drive assembly with a suitable jack to relieve the tension from the leaf spring.
  - The axle weight should be supported, but there should be no compression in the spring.
2. Remove the shock absorber lower nut and bolt using power tool.

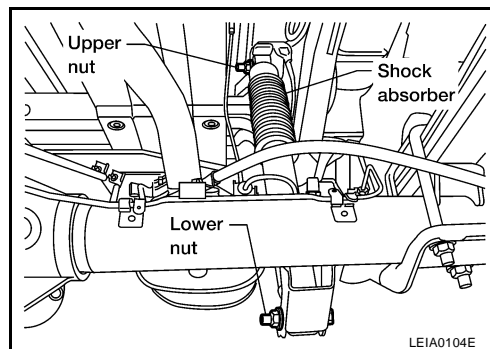

3. Remove the four rear spring clip U-bolt nuts using power tool, then remove the rear spring pad.

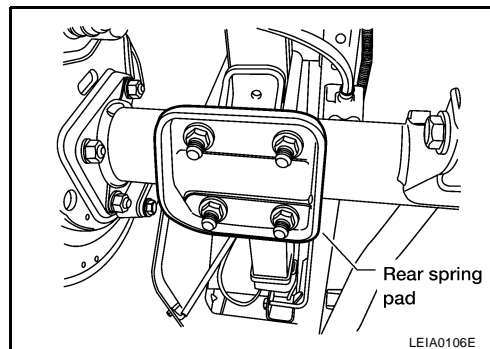

4. Remove the rear spring shackle lower nut and bolt using power tool.
  - If removing the LH rear leaf spring, remove the storage box if equipped, to access the rear spring shackle lower nut and bolt. Refer to [EI-51, "Removal and Installation"](#) .

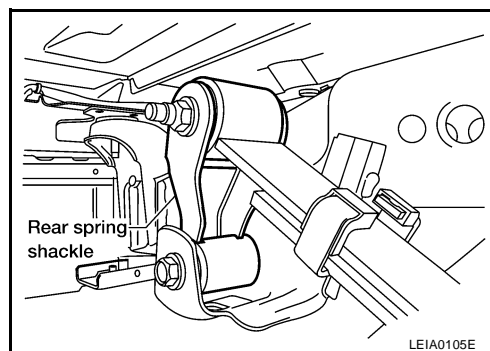

5. Remove the rear leaf spring front nut and bolt using power tool.
6. Remove the rear leaf spring.
7. Remove the rear spring shackle from the rear leaf spring as necessary, using power tool.

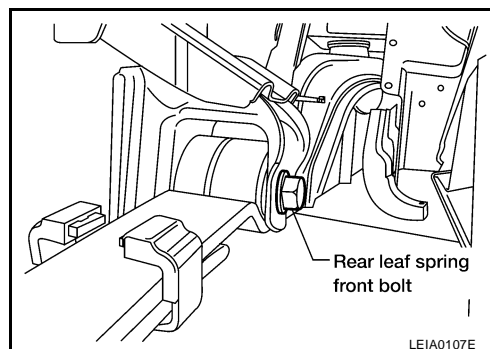

## INSPECTION AFTER REMOVAL

- Check the rear leaf spring for any cracks or damage. Replace the rear leaf spring if necessary.

# LEAF SPRING

- Check the rear spring shackle, rear spring clip U-bolts, bumper, and rear spring pad for excessive wear, cracks, straightness, and damage. Replace any components if necessary.
- Check all bushings for deformation and cracks. Replace any bushings if necessary.

## INSTALLATION

1. Apply soapsuds to all of the rubber bushings.
2. Install the rear spring shackle and rear leaf spring front nut and bolt. Finger-tighten the nuts.
3. Install the rear spring clip U-bolts and bumper on top of the rear leaf spring.
4. Install the rear spring pad, and new rear spring clip U-bolt nuts under the rear final drive axle case.

### CAUTION:

**Use new rear spring clip U-bolt nuts for installation.**

5. Tighten the rear spring clip U-bolt nuts diagonally and evenly using the following sequence:
  - a. Tighten the rear spring clip U-bolt nuts until the rear spring pad contacts the rear final drive axle case.
  - b. Tighten the rear spring clip U-bolt nuts diagonally and evenly to 50 N·m (5.1 kg-m, 37 ft-lb).
  - c. Tighten the rear spring clip U-bolt nuts to specification so the lengths of all the exposed rear spring clip U-bolt threads under the rear spring pad are equal in length as shown.

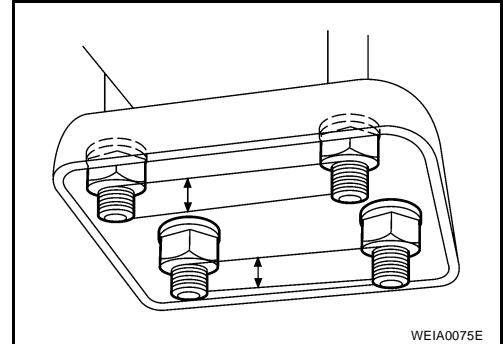

6. Install the shock absorber, and finger-tighten the nuts.
7. Remove the jack supporting the rear final drive assembly and bounce the rear of the vehicle to stabilize the suspension. (unladen)

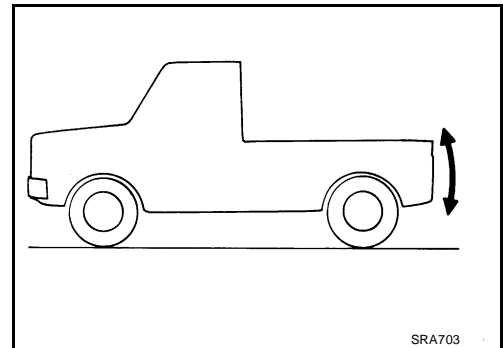

8. Tighten the rear spring shackle nuts, rear leaf spring front nut and shock absorber nuts to specification.

### CAUTION:

**When installing the components with rubber bushings, the final nut tightening must be carried out under unladen\* conditions with the tires on level ground.**

**\* (Fuel, radiator coolant and engine oil full. Spare tire, jack, hand tools and mats in designated positions.)**

# SERVICE DATA AND SPECIFICATIONS (SDS)

## SERVICE DATA AND SPECIFICATIONS (SDS)

PDF:00030

### General Specifications (Rear)

EES001D0

Suspension type	Rigid axle with semi-elliptic leaf spring
Shock absorber type	Double-acting hydraulic

### Wheelarch Height (Unladen\*1)

EES001D1

Unit: mm (in)

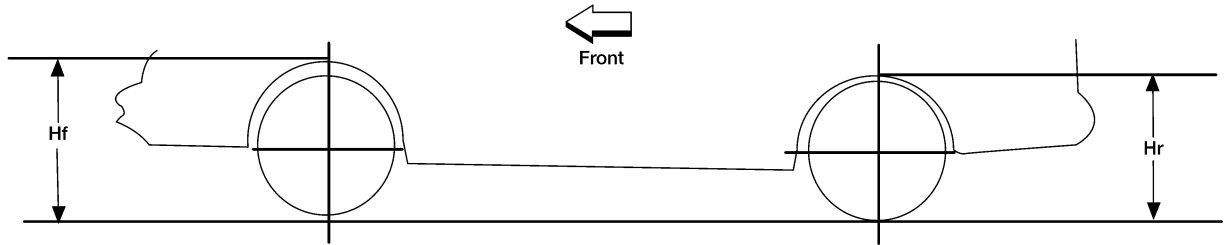

LEIA0085E

Drive type		2WD		4WD	
Body		King Cab	Crew Cab	King Cab	Crew Cab
Front wheelarch height (Hf)	265/70R18	913 (35.9)	916 (36.1)	952 (37.5) *2	955 (37.6) *2
	285/70R17	914 (36.0)	917 (36.1)	953 (37.5) *2	956 (37.6) *2
	245/75R17	904 (35.6)	907 (35.7)	941 (37.0)	944 (37.2)
Rear wheelarch height (Hr)	265/70R18	955 (37.6)	956 (37.6)	995 (39.2) *2	996 (39.2) *2
	285/70R17	956 (37.6)	957 (37.7)	996 (39.2) *2	997 (39.3) *2
	245/75R17	946 (37.2)	947 (37.3)	984 (38.7)	985 (38.8)

\*1: Fuel, radiator coolant and engine oil full. Spare tire, jack, hand tools and mats in designated positions.

\*2: Includes when equipped with tow package.

# SERVICE DATA AND SPECIFICATIONS (SDS)

---