

SECTION **PB**
PARKING BRAKE SYSTEM

A
B
C
D
E
PB
G
H
I
J
K
L
M

CONTENTS

PREPARATION	2	PARKING BRAKE SHOE	6
Commercial Service Tools	2	Removal and Installation	6
PARKING BRAKE SYSTEM	3	COMPONENTS	6
On-Vehicle Service	3	REMOVAL	6
PEDAL STROKE	3	INSPECTION AFTER REMOVAL	7
INSPECTION	3	INSTALLATION	7
ADJUSTMENT	3	SERVICE DATA AND SPECIFICATIONS (SDS)	9
PARKING BRAKE CONTROL	4	Parking Brake	9
Components	4	Parking Brake Control	9
Removal and Installation	4		
REMOVAL	4		
INSTALLATION	5		

PREPARATION

PREPARATION

PF0:00002

Commercial Service Tools

EFS004P1

The actual shapes of Kent-Moore tools may differ from those of special service tools illustrated here.

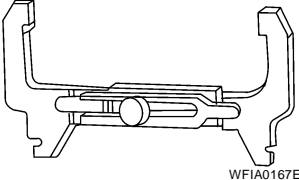
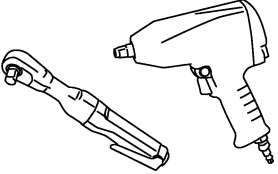
Tool number (Kent-Moore No.) Tool name		Description
— (J-21177-A) Brake drum clearance gauge	 <p>WFIA0167E</p>	Measuring rear rotor drum to parking brake shoe clearance
Power tool	 <p>PBIC0190E</p>	Loosening bolts and nuts

PARKING BRAKE SYSTEM

PARKING BRAKE SYSTEM

PFP:36010

On-Vehicle Service PEDAL STROKE

EF50068V

- When parking brake pedal is operated with the specified force, make sure the stroke is within the specified number of notches. Check by listening and counting the ratchet clicks.

Pedal stroke : 3 – 4 notches [under force of 196 N (20.0 kg-f, 44.1 lb-f)]

INSPECTION

- Make sure the components are attached properly, checking for looseness or backlash.
- Check parking brake pedal assembly for bends, damage and cracks, and replace if necessary.
- Check cable for wear and damage, and replace if necessary.
- Check parking brake warning lamp switch for malfunction, and replace if necessary. Refer to [DI-28, "Wiring Diagram — WARN —"](#).

ADJUSTMENT

- Remove the lower instrument panel LH. Refer to [IP-13, "LOWER INSTRUMENT PANEL LH"](#).
- Partially engage parking brake pedal to access adjusting nut.
- Insert a deep socket wrench to rotate adjusting nut and loosen cable sufficiently. Then, disengage the parking brake pedal.

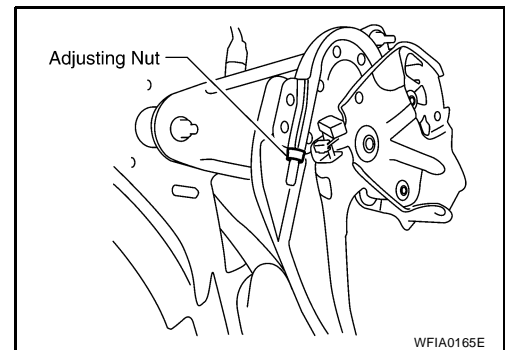

- Remove the wheel and tire using power tool.
- Remove the disc rotor and measure inner diameter at widest point using Tool.

Tool number : — (J-21177-A)

- Transfer measurement less 0.6 mm to the parking brake shoes and adjust accordingly.
- Using wheel nuts, secure the disc rotor to the hub to prevent it from tilting.
- Rotate the disc rotor to make sure there is no drag.
- Adjust cable as follows:
 - Operate pedal 10 or more times with a force of 490 N (50 kg-f, 110 lb-f).
 - Rotate adjusting nut with deep socket to adjust pedal stroke to specification.

Pedal stroke : 3 – 4 notches [under force of 196 N (20.0 kg-f, 44.1 lb-f)]

- With parking brake pedal completely disengaged, make sure there is no drag on the parking brake.
- Install the disc rotor.
 - Install the wheel and tire using power tool.
 - Install the lower instrument panel LH. Refer to [IP-13, "LOWER INSTRUMENT PANEL LH"](#).

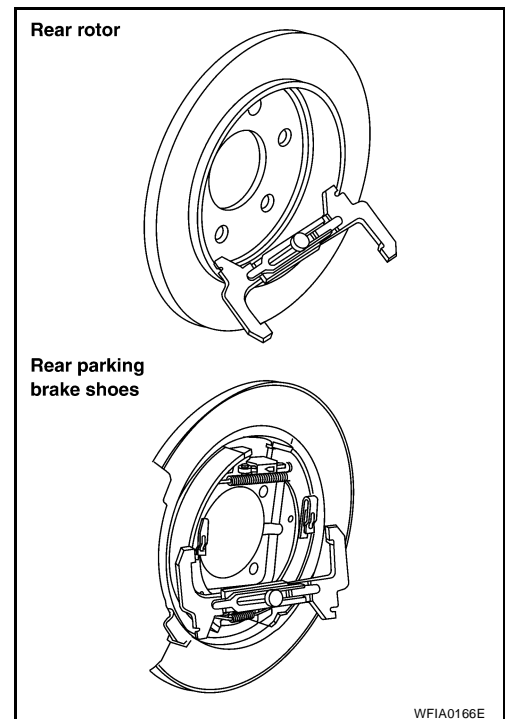

PARKING BRAKE CONTROL

PARKING BRAKE CONTROL

PFP:36010

Components

EFS004P3

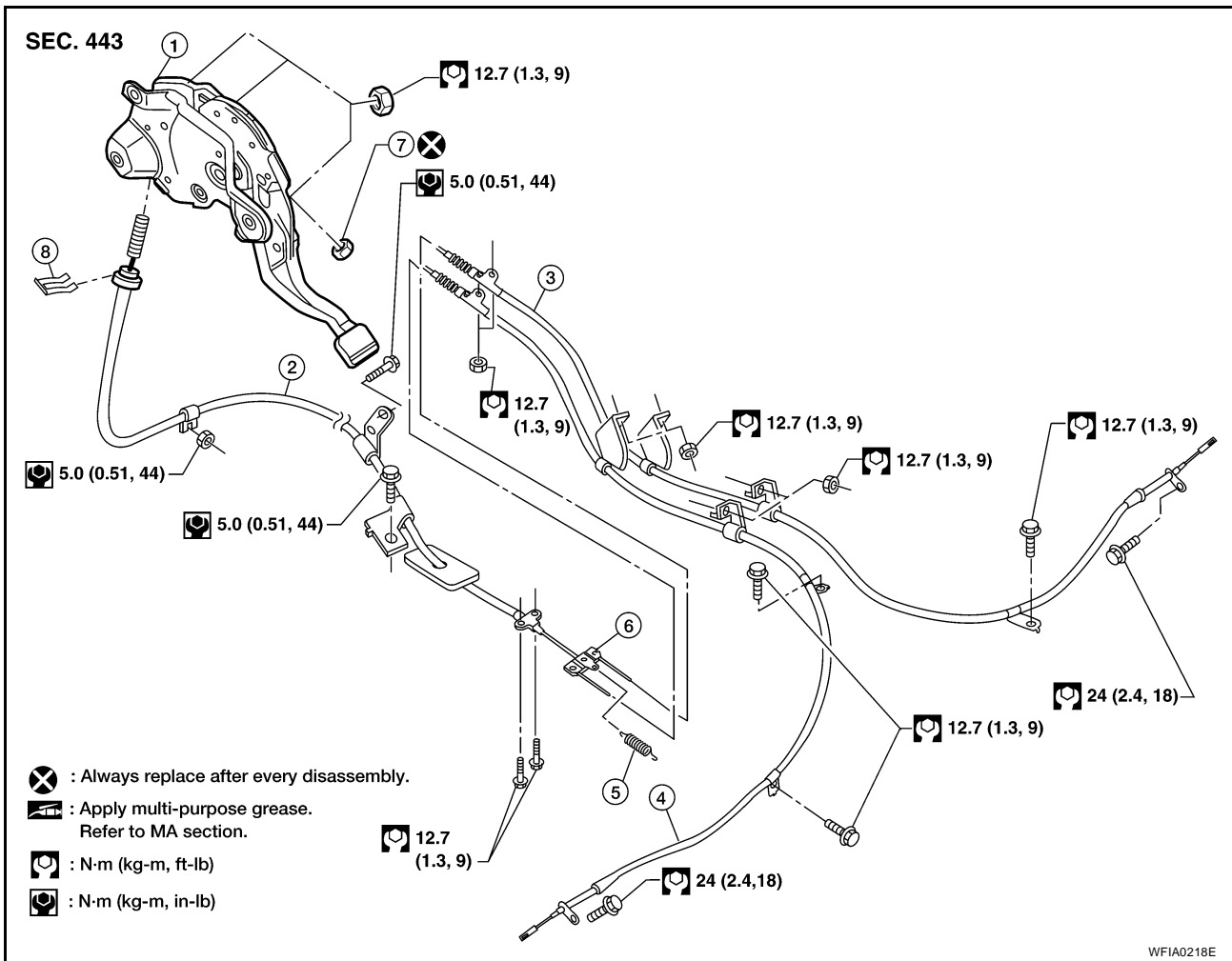

WFIA0218E

- | | | |
|--------------------|------------------|---------------------|
| 1. Pedal assembly | 2. Front cable | 3. Right rear cable |
| 4. Left rear cable | 5. Return spring | 6. Equalizer |
| 7. Adjusting nut | 8. Lock plate | |

Removal and Installation

REMOVAL

EFS004P4

- Remove lower instrument panel. Refer to [IP-13, "LOWER INSTRUMENT PANEL LH"](#) .
- On models with floor shift, remove center console. Refer to [IP-14, "CENTER CONSOLE"](#) .
- Remove floor trim. Refer to [EI-41, "Removal and Installation"](#) .
- Remove adjusting nut.
- Remove the lock plate from the front cable.
- Remove front cable retaining bolts and nut.
- Disconnect return spring from equalizer.
- Disconnect right and left rear cables from equalizer.
- Remove rear disc rotors. Refer to [BR-31, "Removal and Installation of Brake Caliper and Disc Rotor"](#) .
- Remove parking brake shoe, and remove rear cable from toggle lever. Refer to [PB-6, "PARKING BRAKE SHOE"](#) .
- Remove right and left rear cables retaining bolts and nuts, then remove right and left rear cables.

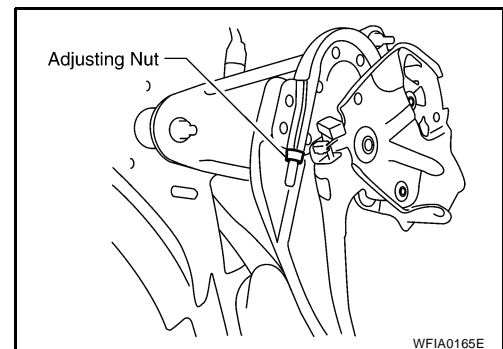

WFIA0165E

PARKING BRAKE CONTROL

INSTALLATION

Installation is in the reverse order of removal.

CAUTION:

Do not reuse adjusting nut after removing it.

- Adjust parking brake. Refer to [PB-3, "ADJUSTMENT"](#) .

A

B

C

D

E

PB

G

H

I

J

K

L

M

PARKING BRAKE SHOE

PFP:44060

PARKING BRAKE SHOE

Removal and Installation COMPONENTS

EFS004P5

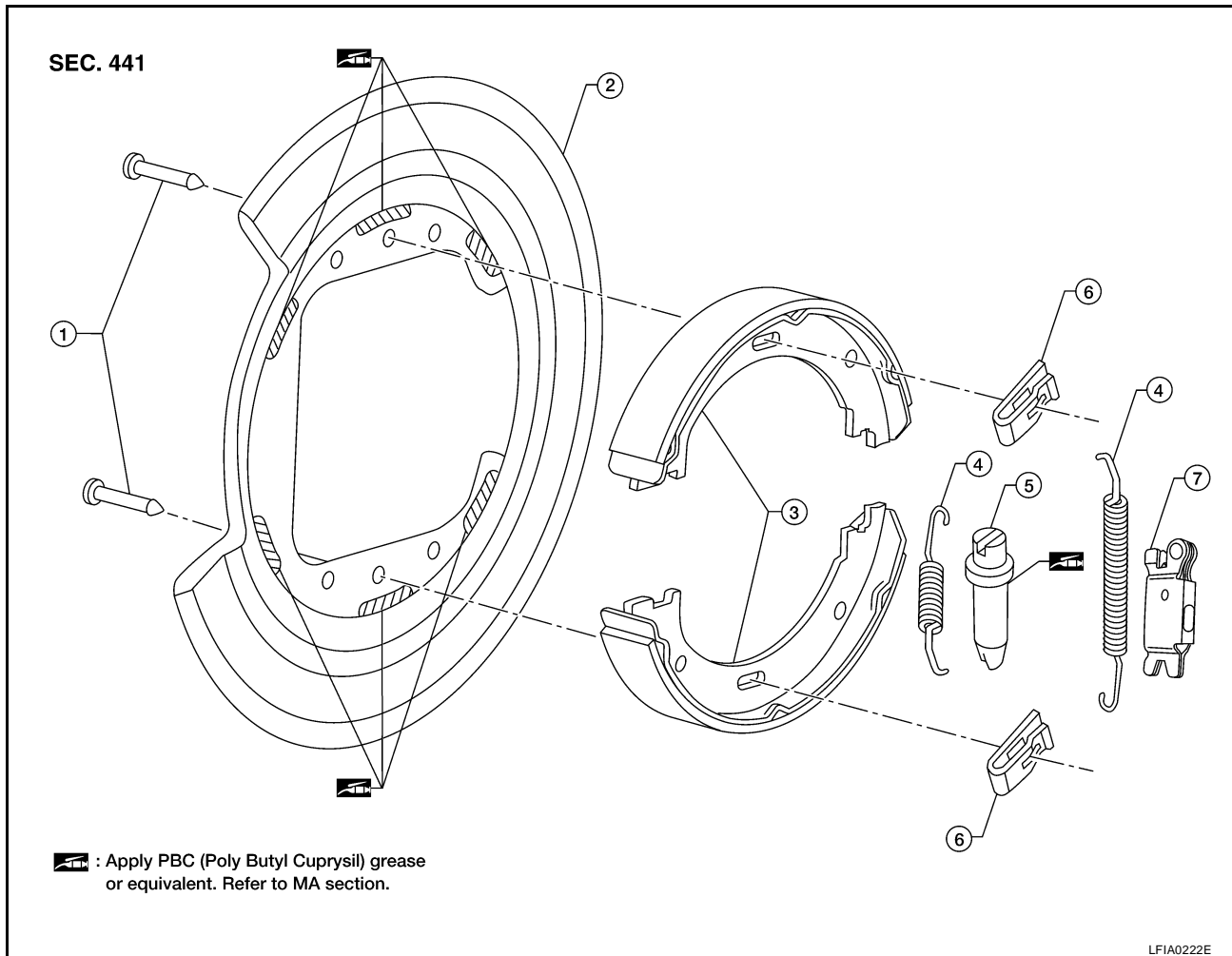

- | | | |
|---------------------|---------------|--------------|
| 1. Anti-rattle pins | 2. Back plate | 3. Shoes |
| 4. Return springs | 5. Adjuster | 6. Retainers |
| 7. Toggle lever | | |

REMOVAL

WARNING:

Clean the brakes with a vacuum dust collector to minimize the hazard of airborne particles or other materials.

NOTE:

Remove the disc rotor only with the parking brake pedal completely in the released position.

1. Remove the rear disc rotor. Refer to [BR-31, "Removal and Installation of Brake Caliper and Disc Rotor"](#).
2. Remove the return springs.
3. Remove the adjuster.
4. Disconnect the rear cable from the toggle lever, if necessary.
 - Remove pin retainer and withdraw cable end from toggle lever.
5. Remove the retainers, anti-rattle pins and shoes.

PARKING BRAKE SHOE

INSPECTION AFTER REMOVAL

Lining Thickness Inspection

- Check thickness of lining.

Standard thickness "A" : 3.79 ± 0.21 mm
(0.149 ± 0.008 in)

Wear limit thickness "A" : 0.5 mm (0.020 in)

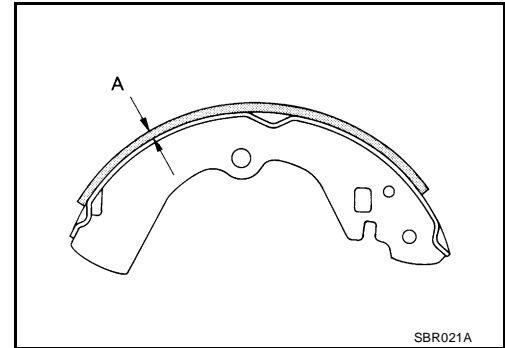

Disc Rotor Inner Diameter Inspection

- Check inner diameter inside drum area of disc rotor.

Standard inner diameter : 205 ± 0.13 mm (8.07 ± 0.01 in)

Wear limit of inner diameter : 205.7 mm (8.10 in)

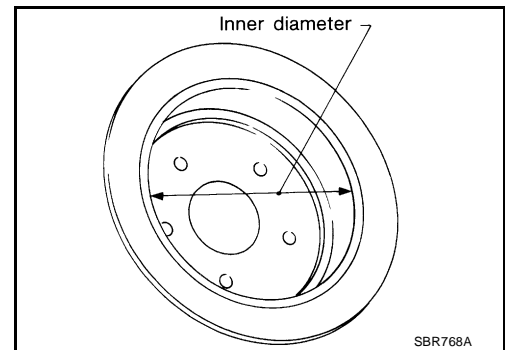

Other Inspections

- Check shoe sliding surface on back plate for excessive wear and damage.
- Check anti-rattle pins for excessive wear and corrosion.
- Check return springs for sagging.
- Check adjuster for rough operation.
- When disassembling adjuster, apply PBC (Poly Butyl Cuprysil) grease or equivalent to the threads. Refer to [MA-11, "RECOMMENDED FLUIDS AND LUBRICANTS"](#).
- Check either visually or with a vernier caliper to see if there is any excessive wear, cracks, or damage inside drum area of disc rotor.

INSTALLATION

Installation is in the reverse order of removal.

- Refer to [PB-6, "COMPONENTS"](#) and apply brake grease to the specified points during assembly.
- Assemble adjuster so that threaded part expands when rotating it in the direction shown by the arrow.
- Shorten adjuster by rotating it.

NOTE:

After replacing brake shoes or disc rotors, or if brakes do not function well, perform break-in operation as follows.

1. Adjust parking brake pedal stroke. Refer to [PB-3, "ADJUSTMENT"](#).

CAUTION:

- To prevent lining from getting too hot, allow a cool off period of approximately 5 minutes after every break-in operation.
- Do not perform excessive break-in operations, because it may cause uneven or early wear of lining.

2. Perform parking brake burnishing operation by driving the vehicle forward under the following conditions:

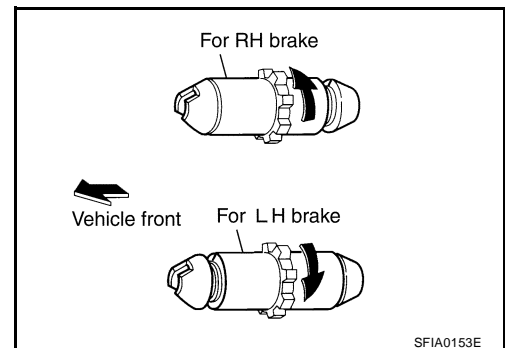

PARKING BRAKE SHOE

- **Vehicle speed at 40 km/h (25 MPH)**
 - **Parking brake operating force of 196 N (20.0 kg-f, 44.1 lb-f) set**
 - **For a period of 30 seconds**
3. After burnishing operation, check pedal stroke of parking brake. Readjust if it is no longer at the specified stroke. Refer to [PB-3, "ADJUSTMENT"](#) .

SERVICE DATA AND SPECIFICATIONS (SDS)

SERVICE DATA AND SPECIFICATIONS (SDS)

PFP:00030

Parking Brake

EFS004P6

Unit: mm (in)

Type	Disc rotor with inner drum	
Brake lining	Standard thickness (new)	3.79 ± 0.21 (0.149 ± 0.008)
	Wear limit thickness	0.5 (0.020)
Drum inner diameter (disc)	Standard inner diameter (new)	205 ± 0.13 (8.07 ± 0.01)
	Wear limit of inner diameter	205.7 (8.10)

Parking Brake Control

EFS004P7

Control type	Foot pedal
Number of notches [under force of 196 N (20.0 kg-f, 44.1 lb-f)]	3 – 4 notches
Number of notches when warning lamp switch comes on	1 notch

A
B
C
D
E
G
H
I
J
K
L
M

PB

SERVICE DATA AND SPECIFICATIONS (SDS)
