

SECTION **RAX**
REAR AXLE

A
B
C

RAX

CONTENTS

E

PRECAUTIONS	2	WHEEL BEARING INSPECTION	5	F
Precautions	2	Removal and Installation	6	
PREPARATION	3	REMOVAL	7	
Special Service Tools	3	INSPECTION AFTER REMOVAL	8	G
Commercial Service Tools	3	INSTALLATION	8	
NOISE, VIBRATION, AND HARSHNESS (NVH)		AXLE BEARING	10	H
TROUBLESHOOTING	4	Removal and Installation	10	
NVH Troubleshooting Chart	4	AXLE OIL SEAL	11	
AXLE SHAFT	5	Removal and Installation	11	
On-Vehicle Inspection	5	SERVICE DATA AND SPECIFICATIONS (SDS)	12	I
REAR AXLE	5	Axle Bearing	12	

J

K

L

M

PRECAUTIONS

PRECAUTIONS

PFP:00001

Precautions

EDS001QG

When installing rubber parts, final tightening must be carried out under unladen condition* with tires on ground.

* Fuel, radiator coolant and engine oil full. Spare tire, jack, hand tools and mats in designated positions.

PREPARATION

PREPARATION

PFP:00002

Special Service Tools

EDS001QH

The actual shapes of Kent-Moore tools may differ from those of special service tools illustrated here.

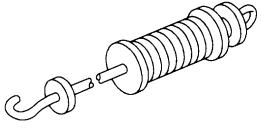
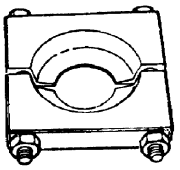
Tool number (Kent-Moore No.) Tool name	Description
KV40101000 (J-25604-01) Axle stand  <p style="text-align: center;">NT159</p>	Removing axle shaft
ST36230000 (J-25840-A) Slide hammer  <p style="text-align: center;">NT126</p>	Removing axle shaft
ST30031000 (—) Bearing splitter  <p style="text-align: center;">ZZA0700D</p>	Removing axle shaft bearing

A
B
C
RAX
E
F
G
H
I
J
K
L
M

Commercial Service Tools

EDS001QI

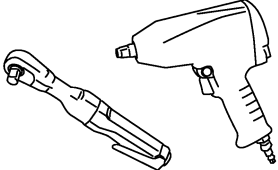
Tool name	Description
Power tools  <p style="text-align: center;">PBIC0190E</p>	Removing and installing nuts and bolts

NOISE, VIBRATION, AND HARSHNESS (NVH) TROUBLESHOOTING

NOISE, VIBRATION, AND HARSHNESS (NVH) TROUBLESHOOTING

PF0:00003

NVH Troubleshooting Chart

EDS001QJ

Use the chart below to help you find the cause of the symptom. If necessary, repair or replace these parts.

Symptom		Possible cause and SUSPECTED PARTS									
		Improper installation, looseness	Parts interference	Wheel bearing damage	PROPELLER SHAFT	REAR FINAL DRIVE	SUSPENSION	TIRES	ROAD WHEEL	BRAKES	
Symptom	Noise	x	x		x	x	x	x	x	x	
	Shake	x	x		x		x	x	x	x	
	Vibration	x	x		x		x	x			
	Shimmy	x	x				x	x	x	x	
	Shudder	x					x	x	x	x	
	Poor quality ride or handling	x	x	x			x	x	x	x	

x: Applicable

AXLE SHAFT

AXLE SHAFT

PFP:38164

On-Vehicle Inspection REAR AXLE

EDS001QK

- Check the axle parts for excessive play, wear, and damage. Replace as necessary.
- Shake each rear wheel to check for excessive play. Repair as necessary.
- Retighten all nuts and bolts to specification. Refer to [RAX-6, "Removal and Installation"](#) .

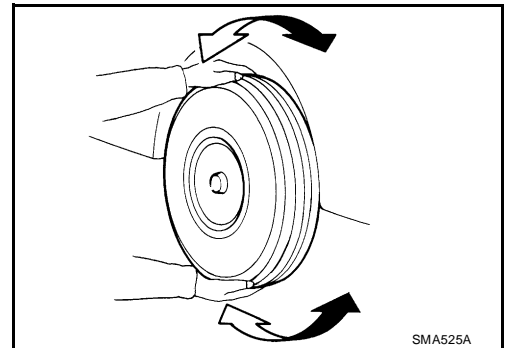

WHEEL BEARING INSPECTION

Check the axial end play, replace as necessary.

- Check that the axle shaft bearing operates smoothly. Replace as necessary.

A
B
C
RAX
E
F
G
H
I
J
K
L
M

AXLE SHAFT

EDS001QL

Removal and Installation

SEC. 381 402 430 431 432

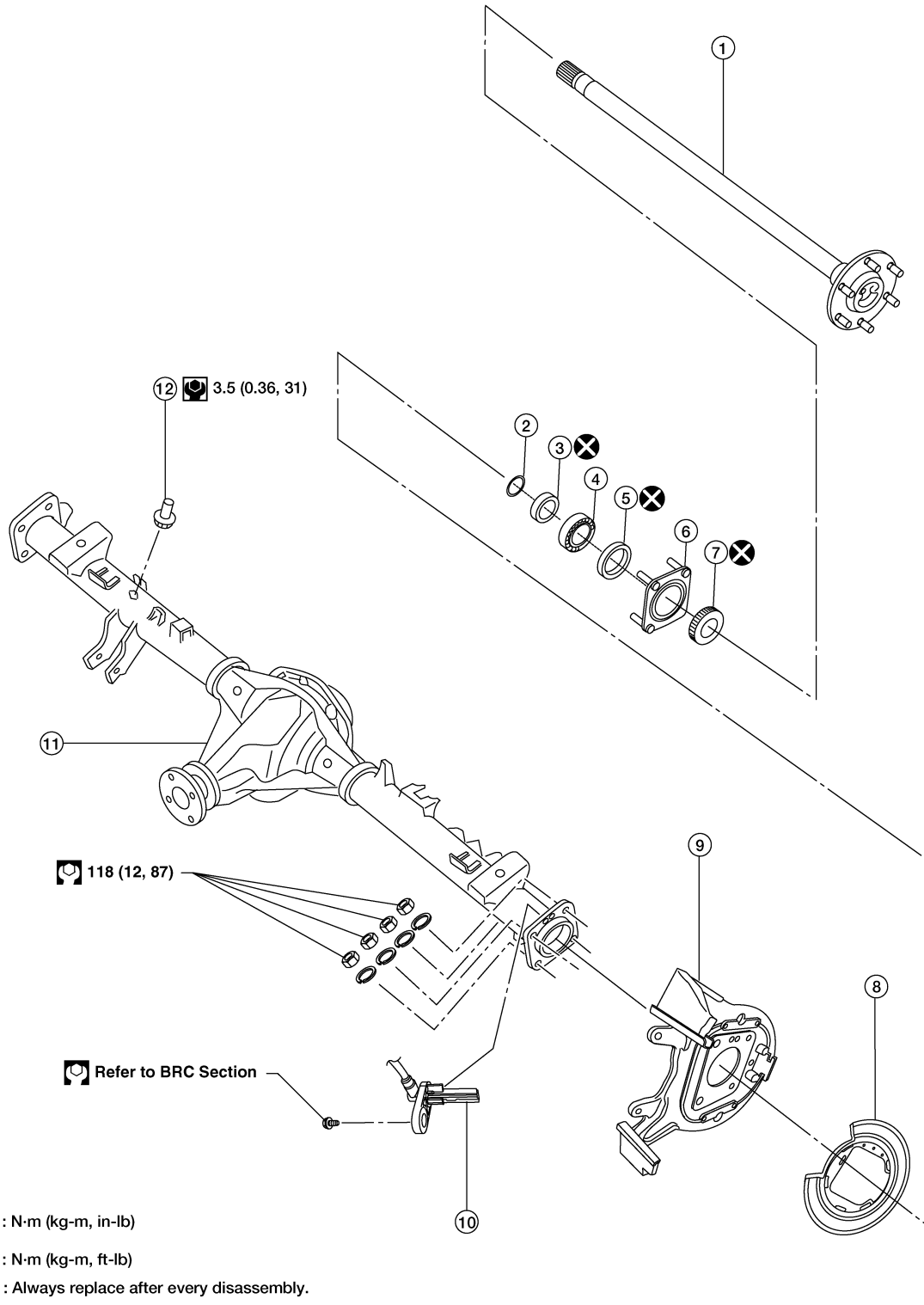

- | | | |
|-------------------------------|----------------------|----------------------------|
| 1. Axle shaft | 2. Snap ring | 3. Bearing ring retainer |
| 4. Axle shaft bearing and cup | 5. Axle oil seal | 6. Axle shaft bearing cage |
| 7. ABS sensor rotor | 8. Back plate | 9. Torque member |
| 10. ABS sensor | 11. Rear final drive | 12. Breather |

WDIA0110E

AXLE SHAFT

CAUTION:

Before removing the axle shaft, remove the ABS sensor to reposition the ABS sensor out of the way. Failure to do so may result in damage to the ABS sensor and cause the ABS sensor to become inoperative.

REMOVAL

1. Remove the ABS sensor. Refer to [BRC-35, "Removal and Installation"](#).
2. Remove the rear brake rotor. Refer to [BR-31, "Removal and Installation of Brake Caliper and Disc Rotor"](#).
3. Remove the parking brake assembly from the back plate. Refer to [PB-6, "Removal and Installation"](#).
4. Remove the four axle shaft bearing cage nuts and lock washers.

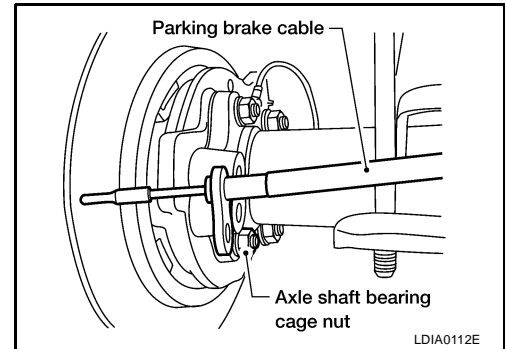

5. Remove the axle shaft assembly using Tools as shown.

CAUTION:

- The axle shaft bearing cup may stay in place in the axle shaft housing. Remove the cup carefully so as not to damage the inner surface of the axle shaft housing.
- Do not reuse the axle oil seal. The axle oil seal must be replaced every time the axle shaft assembly is removed from the axle shaft housing.

Tool number **A: KV40101000 (J-25604-01)**
 B: ST36230000 (J-25840-A)

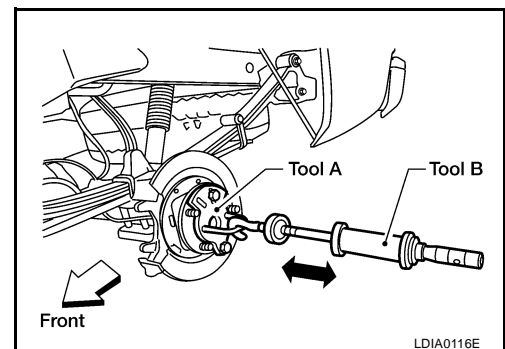

6. Remove the snap ring from the axle shaft using suitable snap ring pliers.
7. Secure the axle shaft in a suitable vise, then use a 1/4 in size drill bit to drill a hole approximately 3/4 into the thickness of the bearing ring retainer [3/4 thickness is approximately 6.3 mm (0.25 in) deep].

CAUTION:

- Mount the axle shaft using a soft jaw vise to avoid damaging the axle shaft.
- Do not drill all the way through the bearing ring retainer, the drill may damage the axle shaft surface.

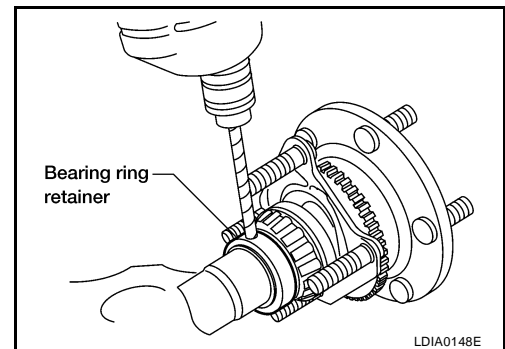

8. Strike the bearing ring retainer using a suitable chisel and hammer, with the chisel positioned across the drilled hole. Break the bearing ring retainer to remove it.

CAUTION:

Do not heat or cut the axle shaft bearing or bearing ring retainer with a torch during removal, doing so will damage the axle shaft.

9. Remove the axle shaft bearing cage studs using a suitable hammer or press.

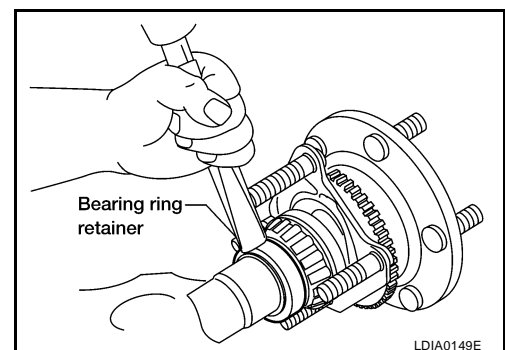

AXLE SHAFT

10. Pull the axle shaft bearing off of the axle shaft using Tool and a suitable press.

Tool number : ST30031000 (—)

CAUTION:

- Do not tighten the Tool against the axle shaft.
- Do not heat or cut the axle shaft bearing or bearing ring retainer with a torch during removal, doing so will damage the axle shaft.

11. Remove the axle oil seal and discard.

CAUTION:

Do not reuse the axle oil seal. The axle oil seal must be replaced every time the axle shaft assembly is removed from the axle shaft housing.

12. Remove the wheel bearing cage.

NOTE:

- If reinstalling the old axle shaft, it may not be necessary to remove the ABS sensor rotor. Inspect the ABS sensor rotor and replace as necessary. Refer to [BRC-36, "Removal and Installation"](#) .
- The ABS sensor rotor cannot be reused after it is removed. If replacing the axle shaft, install a new ABS sensor rotor on the new axle shaft. Refer to [BRC-36, "Removal and Installation"](#) .

INSPECTION AFTER REMOVAL

Axle Shaft

- Clean and remove all nicks and burrs.
- Check for straightness and distortion. Replace if necessary.
- Inspect machined surfaces for evidence of overheating, damage and wear. Replace if necessary.
- Measure the bearing ring retainer axle journal diameter. Replace if necessary.

Bearing ring retainer axle journal diameter (minimum) : 39.726 mm (1.5640 in)

Axle Shaft Bearing and Cup

- Check that the axle shaft bearing and cup roll freely and are free from noise, cracks, pitting and wear. Replace if necessary.

Axle Shaft Bearing Cage

- Check for deformation and cracks. Replace if necessary.

Axle Shaft Housing

- Check the exterior and inner machined surfaces for deformation and cracks. Replace if necessary.

INSTALLATION

1. If installing a new axle shaft, install a new ABS sensor rotor onto the new axle shaft. Refer to [BRC-36, "Removal and Installation"](#) .

CAUTION:

Do not reuse the old ABS sensor rotor.

2. Install the axle shaft bearing cage.

3. Install a new axle oil seal.

CAUTION:

Do not reuse the axle oil seal. The axle oil seal must be replaced every time the axle shaft assembly is removed from the axle shaft housing.

4. Install the axle shaft bearing and cup on the axle shaft.

- Prepare an installer tool from a steel tube measuring 762 mm (30 in) long with an outside diameter of 53.98 mm (2.125 in) and an inside diameter of 41.28 mm (1.625 in).
- Press the axle shaft bearing and cup onto the axle shaft using a suitable press and the installer tool, until a 0.038 mm (.0015 in) feeler gauge does not fit in between the axle shaft bearing cup and seat.

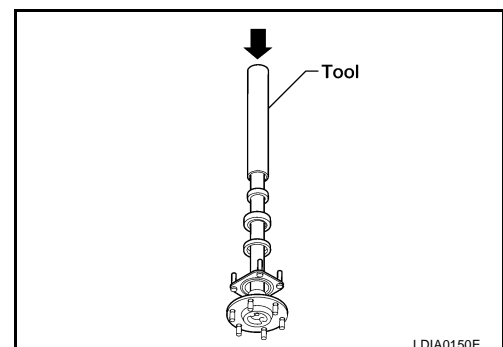

AXLE SHAFT

CAUTION:

Make sure the axle shaft bearing and cup, axle oil seal, and axle shaft bearing cage are installed facing in the correct direction.

5. Install the bearing ring retainer onto the axle shaft.
 - Press the bearing ring retainer onto the axle shaft with a minimum force of 31,100 N (3172 kg, 6992 lb) until a 0.038 mm (.0015 in) feeler gauge does not fit between the bearing inner race and the bearing ring retainer in at least one point.
6. Install the snap ring so it is fully seated into the groove on the axle shaft, using suitable snap ring pliers.
7. Install the axle shaft assembly into the axle shaft housing.
8. Install the axle shaft bearing cage lock washers and nuts. Tighten the axle shaft bearing cage nuts to specification.
9. Install the parking brake assembly onto the back plate. Refer to [PB-6, "Removal and Installation"](#) .
10. Install the rear brake rotor. Refer to [BR-31, "Removal and Installation of Brake Caliper and Disc Rotor"](#) .
11. Install the rear ABS sensor. Refer to [BRC-35, "Removal and Installation"](#) .

A

B

C

RAX

E

F

G

H

I

J

K

L

M

AXLE BEARING

AXLE BEARING

PF:40120

Removal and Installation

EDS001QM

The axle oil seal and bearing ring retainer must be replaced every time the axle shaft is removed and installed. Refer to [RAX-10, "Removal and Installation"](#).

CAUTION:

Do not reuse the axle oil seal. The axle oil seal must be replaced every time the axle shaft assembly is removed from the axle shaft housing.

AXLE OIL SEAL

AXLE OIL SEAL

PFP:43252

Removal and Installation

EDS001QN

The axle oil seal and bearing ring retainer must be replaced every time the axle shaft is removed and installed. Refer to [RAX-11, "Removal and Installation"](#).

CAUTION:

Do not reuse the axle oil seal. The axle oil seal must be replaced every time the axle shaft assembly is removed from the axle shaft housing.

A
B
C

RAX

E
F
G
H
I
J
K
L
M

SERVICE DATA AND SPECIFICATIONS (SDS)

SERVICE DATA AND SPECIFICATIONS (SDS)

PF0:00030

Axle Bearing

EDS00100

Bearing ring retainer axle journal diameter (minimum)	39.726 mm (1.5640 in) minimum
---	-------------------------------
