

A  
B  
C  
D  
E

# SECTION **BRC**

## BRAKE CONTROL SYSTEM

### CONTENTS

		<b>BRC</b>
<b>ABS</b>		
<b>BASIC INSPECTION</b> .....	7	
<b>DIAGNOSIS AND REPAIR WORKFLOW</b> .....	7	
Work Flow .....	7	
Diagnostic Work Sheet .....	9	
<b>FUNCTION DIAGNOSIS</b> .....	10	
<b>ABS</b> .....	10	
System Diagram .....	10	
System Description .....	10	
Component Parts Location .....	11	
Component Description .....	11	
<b>EBD</b> .....	13	
System Diagram .....	13	
System Description .....	13	
Component Parts Location .....	14	
Component Description .....	14	
<b>DIAGNOSIS SYSTEM [ABS ACTUATOR AND ELECTRIC UNIT (CONTROL UNIT)]</b> .....	16	
CONSULT-III Function (ABS) .....	16	
<b>COMPONENT DIAGNOSIS</b> .....	19	
<b>C1101, C1102, C1103, C1104 WHEEL SENSOR-1</b> .....	19	
Description .....	19	
DTC Logic .....	19	
Diagnosis Procedure .....	19	
Component Inspection .....	21	
<b>C1105, C1106, C1107, C1108 WHEEL SENSOR-2</b> .....	22	
Description .....	22	
DTC Logic .....	22	
Diagnosis Procedure .....	22	
Component Inspection .....	24	
<b>C1109 POWER AND GROUND SYSTEM</b> .....	25	
Description .....	25	
DTC Logic .....	25	
Diagnosis Procedure .....	25	
<b>C1110, C1113 ABS ACTUATOR AND ELECTRIC UNIT (CONTROL UNIT)</b> .....	27	
DTC Logic .....	27	
Diagnosis Procedure .....	27	
<b>C1111 ABS MOTOR, MOTOR RELAY SYSTEM</b> .....	28	
Description .....	28	
DTC Logic .....	28	
Diagnosis Procedure .....	28	
Component Inspection .....	29	
<b>C1115 WHEEL SENSOR</b> .....	30	
Description .....	30	
DTC Logic .....	30	
Diagnosis Procedure .....	30	
Component Inspection .....	31	
<b>C1116 STOP LAMP SWITCH</b> .....	33	
Description .....	33	
DTC Logic .....	33	
Diagnosis Procedure .....	33	
<b>C1120, C1122, C1190 IN ABS SOL</b> .....	34	
Description .....	34	
DTC Logic .....	34	
Diagnosis Procedure .....	34	
Component Inspection .....	35	
<b>C1121, C1123, C1191 OUT ABS SOL</b> .....	36	
Description .....	36	
DTC Logic .....	36	
Diagnosis Procedure .....	36	
Component Inspection .....	37	
<b>C1140 ACTUATOR RLY</b> .....	38	
Description .....	38	

DTC Logic .....	38	<b>PREPARATION .....</b>	<b>61</b>
Diagnosis Procedure .....	38	<b>PREPARATION .....</b>	<b>61</b>
Component Inspection .....	39	Special Service Tool .....	61
<b>U1000 CAN COMM CIRCUIT .....</b>	<b>40</b>	Commercial Service Tool .....	61
Description .....	40	<b>REMOVAL AND INSTALLATION .....</b>	<b>62</b>
DTC Logic .....	40	<b>WHEEL SENSORS .....</b>	<b>62</b>
Diagnosis Procedure .....	40	Removal and Installation .....	62
<b>ABS WARNING LAMP .....</b>	<b>41</b>	<b>SENSOR ROTOR .....</b>	<b>63</b>
Description .....	41	Removal and Installation .....	63
Component Function Check .....	41	<b>ACTUATOR AND ELECTRIC UNIT (ASSEMBLY) .....</b>	<b>64</b>
Diagnosis Procedure .....	41	Removal and Installation .....	64
<b>BRAKE WARNING LAMP .....</b>	<b>42</b>	<b>ABLS/ABS</b>	
Description .....	42	<b>BASIC INSPECTION .....</b>	<b>66</b>
Component Function Check .....	42	<b>DIAGNOSIS AND REPAIR WORKFLOW .....</b>	<b>66</b>
Diagnosis Procedure .....	42	Work Flow .....	66
<b>ECU DIAGNOSIS .....</b>	<b>43</b>	Diagnostic Work Sheet .....	68
<b>ABS ACTUATOR AND ELECTRIC UNIT (CONTROL UNIT) .....</b>	<b>43</b>	<b>FUNCTION DIAGNOSIS .....</b>	<b>69</b>
Reference Value .....	43	<b>ABLS .....</b>	<b>69</b>
Wiring Diagram .....	45	System Diagram .....	69
Fail-Safe .....	50	System Description .....	69
DTC No. Index .....	51	Component Parts Location .....	70
<b>SYMPTOM DIAGNOSIS .....</b>	<b>52</b>	Component Description .....	71
<b>ABS .....</b>	<b>52</b>	<b>ABS .....</b>	<b>72</b>
Symptom Table .....	52	System Diagram .....	72
<b>EXCESSIVE ABS FUNCTION OPERATION FREQUENCY .....</b>	<b>53</b>	System Description .....	72
Diagnosis Procedure .....	53	Component Parts Location .....	73
<b>UNEXPECTED PEDAL REACTION .....</b>	<b>54</b>	Component Description .....	73
Diagnosis Procedure .....	54	<b>EBD .....</b>	<b>75</b>
<b>THE BRAKING DISTANCE IS LONG .....</b>	<b>55</b>	System Diagram .....	75
Diagnosis Procedure .....	55	System Description .....	75
<b>ABS FUNCTION DOES NOT OPERATE .....</b>	<b>56</b>	Component Parts Location .....	76
Diagnosis Procedure .....	56	Component Description .....	76
<b>PEDAL VIBRATION OR ABS OPERATION SOUND OCCURS .....</b>	<b>57</b>	<b>DIAGNOSIS SYSTEM [ABS ACTUATOR AND ELECTRIC UNIT (CONTROL UNIT)] .....</b>	<b>78</b>
Diagnosis Procedure .....	57	CONSULT-III Function (ABS) .....	78
<b>NORMAL OPERATING CONDITION .....</b>	<b>58</b>	<b>COMPONENT DIAGNOSIS .....</b>	<b>82</b>
Description .....	58	<b>C1101, C1102, C1103, C1104 WHEEL SENSOR-1 .....</b>	<b>82</b>
<b>PRECAUTION .....</b>	<b>59</b>	Description .....	82
<b>PRECAUTIONS .....</b>	<b>59</b>	DTC Logic .....	82
Precaution for Supplemental Restraint System (SRS) "AIR BAG" and "SEAT BELT PRE-TENSIONER" .....	59	Diagnosis Procedure .....	82
Precaution for Brake System .....	59	Component Inspection .....	84
Precaution for Brake Control .....	59	<b>C1105, C1106, C1107, C1108 WHEEL SENSOR-2 .....</b>	<b>85</b>
Precaution for CAN System .....	60	Description .....	85

DTC Logic .....	85	<b>C1155 BRAKE FLUID LEVEL SWITCH</b> .....	109	A
Diagnosis Procedure .....	85	Description .....	109	
Component Inspection .....	87	DTC Logic .....	109	
<b>C1109 POWER AND GROUND SYSTEM</b> .....	<b>88</b>	Diagnosis Procedure .....	109	B
Description .....	88	Component Inspection .....	110	
DTC Logic .....	88	<b>C1164, C1165, C1166, C1167 CV/SV SYS-</b>		
Diagnosis Procedure .....	88	<b>TEM</b> .....	<b>111</b>	C
<b>C1110, C1113, C1160, C1170 ABS ACTUA-</b>		Description .....	111	
<b>TOR AND ELECTRIC UNIT (CONTROL UNIT)</b>		DTC Logic .....	111	
	<b>90</b>	Diagnosis Procedure .....	111	D
DTC Logic .....	90	Component Inspection .....	112	
Diagnosis Procedure .....	90	<b>C1187 DIFFERENTIAL LOCK CONTROL</b>		
<b>C1111 ABS MOTOR, MOTOR RELAY SYS-</b>		<b>UNIT</b> .....	<b>114</b>	E
<b>TEM</b> .....	<b>91</b>	Description .....	114	
Description .....	91	DTC Logic .....	114	
DTC Logic .....	91	Diagnosis Procedure .....	114	
Diagnosis Procedure .....	91	<b>U1000 CAN COMM CIRCUIT</b> .....	<b>115</b>	BRC
Component Inspection .....	92	Description .....	115	
<b>C1115 WHEEL SENSOR</b> .....	<b>93</b>	DTC Logic .....	115	G
Description .....	93	Diagnosis Procedure .....	115	
DTC Logic .....	93	<b>ABS WARNING LAMP</b> .....	<b>116</b>	H
Diagnosis Procedure .....	93	Description .....	116	
Component Inspection .....	94	Component Function Check .....	116	
<b>C1116 STOP LAMP SWITCH</b> .....	<b>96</b>	Diagnosis Procedure .....	116	
Description .....	96	<b>BRAKE WARNING LAMP</b> .....	<b>117</b>	I
DTC Logic .....	96	Description .....	117	
Diagnosis Procedure .....	96	Component Function Check .....	117	J
<b>C1120, C1122, C1124, C1126 IN ABS SOL</b> .....	<b>97</b>	Diagnosis Procedure .....	117	
Description .....	97	<b>SLIP INDICATOR LAMP</b> .....	<b>118</b>	K
DTC Logic .....	97	Description .....	118	
Diagnosis Procedure .....	97	Component Function Check .....	118	
Component Inspection .....	98	Diagnosis Procedure .....	118	
<b>C1121, C1123, C1125, C1127 OUT ABS SOL</b> .....	<b>100</b>	<b>ECU DIAGNOSIS</b> .....	<b>119</b>	L
Description .....	100	<b>ABS ACTUATOR AND ELECTRIC UNIT</b>		
DTC Logic .....	100	<b>(CONTROL UNIT)</b> .....	<b>119</b>	M
Diagnosis Procedure .....	100	Reference Value .....	119	
Component Inspection .....	101	Wiring Diagram .....	123	
<b>C1130, C1131, C1136 ENGINE SIGNAL</b> .....	<b>103</b>	Fail-Safe .....	129	
Description .....	103	DTC No. Index .....	130	N
DTC Logic .....	103	<b>SYMPTOM DIAGNOSIS</b> .....	<b>132</b>	O
Diagnosis Procedure .....	103	<b>ABLS/ABS</b> .....	<b>132</b>	
<b>C1140 ACTUATOR RLY</b> .....	<b>104</b>	Symptom Table .....	132	
Description .....	104	<b>EXCESSIVE ABS FUNCTION OPERATION</b>		
DTC Logic .....	104	<b>FREQUENCY</b> .....	<b>133</b>	P
Diagnosis Procedure .....	104	Diagnosis Procedure .....	133	
Component Inspection .....	105	<b>UNEXPECTED PEDAL REACTION</b> .....	<b>134</b>	
<b>C1142 PRESS SENSOR</b> .....	<b>106</b>	Diagnosis Procedure .....	134	
Description .....	106	<b>THE BRAKING DISTANCE IS LONG</b> .....	<b>135</b>	
DTC Logic .....	106			
Diagnosis Procedure .....	106			
Component Inspection .....	108			

Diagnosis Procedure .....	135	ADJUSTMENT OF STEERING ANGLE SENSOR NEUTRAL POSITION : Special Repair Require- ment .....	150
<b>ABS FUNCTION DOES NOT OPERATE .....</b>	<b>136</b>	<b>CALIBRATION OF DECEL G SENSOR .....</b>	<b>151</b>
Diagnosis Procedure .....	136	CALIBRATION OF DECEL G SENSOR : Descrip- tion .....	151
<b>PEDAL VIBRATION OR ABS OPERATION SOUND OCCURS .....</b>	<b>137</b>	CALIBRATION OF DECEL G SENSOR : Special Repair Requirement .....	151
Diagnosis Procedure .....	137	<b>FUNCTION DIAGNOSIS .....</b>	<b>153</b>
<b>NORMAL OPERATING CONDITION .....</b>	<b>138</b>	<b>VDC .....</b>	<b>153</b>
Description .....	138	System Diagram .....	153
<b>PRECAUTION .....</b>	<b>139</b>	System Description .....	153
<b>PRECAUTIONS .....</b>	<b>139</b>	Component Parts Location .....	154
Precaution for Supplemental Restraint System (SRS) "AIR BAG" and "SEAT BELT PRE-TEN- SIONER" .....	139	Component Description .....	155
Precaution for Brake System .....	139	<b>TCS .....</b>	<b>156</b>
Precaution for Brake Control .....	139	System Diagram .....	156
Precaution for CAN System .....	140	System Description .....	156
<b>PREPARATION .....</b>	<b>141</b>	Component Parts Location .....	157
<b>PREPARATION .....</b>	<b>141</b>	Component Description .....	158
Special Service Tool .....	141	<b>ABS .....</b>	<b>159</b>
Commercial Service Tool .....	141	System Diagram .....	159
<b>REMOVAL AND INSTALLATION .....</b>	<b>142</b>	System Description .....	159
<b>WHEEL SENSORS .....</b>	<b>142</b>	Component Parts Location .....	160
Removal and Installation .....	142	Component Description .....	161
<b>SENSOR ROTOR .....</b>	<b>143</b>	<b>EBD .....</b>	<b>162</b>
Removal and Installation .....	143	System Diagram .....	162
<b>ACTUATOR AND ELECTRIC UNIT (ASSEM- BLY) .....</b>	<b>144</b>	System Description .....	162
Removal and Installation .....	144	Component Parts Location .....	163
<b>VDC/TCS/ABS</b>		Component Description .....	164
<b>BASIC INSPECTION .....</b>	<b>146</b>	<b>DIAGNOSIS SYSTEM [ABS ACTUATOR AND ELECTRIC UNIT (CONTROL UNIT)] .....</b>	<b>165</b>
<b>DIAGNOSIS AND REPAIR WORKFLOW .....</b>	<b>146</b>	CONSULT-III Function (ABS) .....	165
Work Flow .....	146	<b>COMPONENT DIAGNOSIS .....</b>	<b>170</b>
Diagnostic Work Sheet .....	149	<b>C1101, C1102, C1103, C1104 WHEEL SEN- SOR-1 .....</b>	<b>170</b>
<b>INSPECTION AND ADJUSTMENT .....</b>	<b>150</b>	Description .....	170
<b>ADDITIONAL SERVICE WHEN REPLACING CONTROL UNIT .....</b>	<b>150</b>	DTC Logic .....	170
ADDITIONAL SERVICE WHEN REPLACING CONTROL UNIT : Description .....	150	Diagnosis Procedure .....	170
ADDITIONAL SERVICE WHEN REPLACING CONTROL UNIT : Special Repair Requirement ...	150	Component Inspection .....	172
<b>ADJUSTMENT OF STEERING ANGLE SENSOR NEUTRAL POSITION .....</b>	<b>150</b>	Special Repair Requirement .....	172
ADJUSTMENT OF STEERING ANGLE SENSOR NEUTRAL POSITION : Description .....	150	<b>C1105, C1106, C1107, C1108 WHEEL SEN- SOR-2 .....</b>	<b>173</b>
		Description .....	173
		DTC Logic .....	173
		Diagnosis Procedure .....	173
		Component Inspection .....	175
		Special Repair Requirement .....	175
		<b>C1109 POWER AND GROUND SYSTEM .....</b>	<b>176</b>
		Description .....	176
		DTC Logic .....	176

Diagnosis Procedure .....	176	DTC Logic .....	197	
Special Repair Requirement .....	177	Diagnosis Procedure .....	197	A
<b>C1110, C1170 ABS ACTUATOR AND ELEC- TRIC UNIT (CONTROL UNIT) .....</b>	<b>178</b>	Component Inspection .....	198	
DTC Logic .....	178	Special Repair Requirement .....	198	B
Diagnosis Procedure .....	178	<b>C1142 PRESS SENSOR .....</b>	<b>199</b>	
Special Repair Requirement .....	178	Description .....	199	C
<b>C1111 ABS MOTOR, MOTOR RELAY SYS- TEM .....</b>	<b>179</b>	DTC Logic .....	199	
Description .....	179	Diagnosis Procedure .....	199	
DTC Logic .....	179	Component Inspection .....	201	D
Diagnosis Procedure .....	179	Special Repair Requirement .....	201	
Component Inspection .....	180	<b>C1143, C1144 STEERING ANGLE SENSOR .</b>	<b>202</b>	
Special Repair Requirement .....	180	Description .....	202	E
<b>C1113, C1145, C1146 YAW RATE/SIDE/DE- CEL G SENSOR .....</b>	<b>181</b>	DTC Logic .....	202	
Description .....	181	Diagnosis Procedure .....	202	
DTC Logic .....	181	Component Inspection .....	203	
Diagnosis Procedure .....	181	Special Repair Requirement .....	203	
Component Inspection .....	182	<b>C1155 BRAKE FLUID LEVEL SWITCH .....</b>	<b>205</b>	BRC
Special Repair Requirement .....	182	Description .....	205	
<b>C1115 WHEEL SENSOR .....</b>	<b>184</b>	DTC Logic .....	205	G
Description .....	184	Diagnosis Procedure .....	205	
DTC Logic .....	184	Component Inspection .....	206	
Diagnosis Procedure .....	184	Special Repair Requirement .....	206	H
Component Inspection .....	185	<b>C1156 ST ANG SEN COM CIR .....</b>	<b>208</b>	
Special Repair Requirement .....	186	Description .....	208	I
<b>C1116 STOP LAMP SWITCH .....</b>	<b>187</b>	DTC Logic .....	208	
Description .....	187	Diagnosis Procedure .....	208	
DTC Logic .....	187	<b>C1160 DECEL G SEN SET .....</b>	<b>209</b>	J
Diagnosis Procedure .....	187	Description .....	209	
Special Repair Requirement .....	188	DTC Logic .....	209	
<b>C1120, C1122, C1124, C1126 IN ABS SOL ...</b>	<b>189</b>	Diagnosis Procedure .....	209	
Description .....	189	<b>C1163 ST ANGLE SEN SAFE .....</b>	<b>210</b>	K
DTC Logic .....	189	Description .....	210	
Diagnosis Procedure .....	189	DTC Logic .....	210	L
Component Inspection .....	190	Diagnosis Procedure .....	210	
Special Repair Requirement .....	191	<b>C1164, C1165, C1166, C1167 CV/SV SYS- TEM .....</b>	<b>211</b>	M
<b>C1121, C1123, C1125, C1127 OUT ABS SOL.</b>	<b>192</b>	Description .....	211	
Description .....	192	DTC Logic .....	211	
DTC Logic .....	192	Diagnosis Procedure .....	211	
Diagnosis Procedure .....	192	Component Inspection .....	212	N
Component Inspection .....	193	Special Repair Requirement .....	213	
Special Repair Requirement .....	194	<b>C1178, C1181, C1184, C1189 ABS ACTIVE BOOSTER .....</b>	<b>214</b>	O
<b>C1130, C1131, C1132, C1133, C1136 EN- GINE SIGNAL .....</b>	<b>195</b>	Description .....	214	
Description .....	195	DTC Logic .....	214	P
DTC Logic .....	195	Diagnosis Procedure .....	214	
Diagnosis Procedure .....	195	Component Inspection .....	215	
Special Repair Requirement .....	195	Special Repair Requirement .....	216	
<b>C1140 ACTUATOR RLY .....</b>	<b>197</b>	<b>C1179 ABS DELTA S SEN NG .....</b>	<b>217</b>	
Description .....	197	Description .....	217	
		DTC Logic .....	217	
		Diagnosis Procedure .....	217	

Component Inspection .....	218	<b>UNEXPECTED PEDAL REACTION .....</b>	<b>243</b>
Special Repair Requirement .....	218	Diagnosis Procedure .....	243
<b>U1000 CAN COMM CIRCUIT .....</b>	<b>219</b>	<b>THE BRAKING DISTANCE IS LONG .....</b>	<b>244</b>
Description .....	219	Diagnosis Procedure .....	244
DTC Logic .....	219	<b>ABS FUNCTION DOES NOT OPERATE .....</b>	<b>245</b>
Diagnosis Procedure .....	219	Diagnosis Procedure .....	245
Special Repair Requirement .....	219	<b>PEDAL VIBRATION OR ABS OPERATION</b>	
<b>VDC OFF SWITCH .....</b>	<b>220</b>	<b>SOUND OCCURS .....</b>	<b>246</b>
Description .....	220	Diagnosis Procedure .....	246
Component Function Check .....	220	<b>VEHICLE JERKS DURING VDC/TCS/ABS</b>	
Diagnosis Procedure .....	220	<b>CONTROL .....</b>	<b>247</b>
Component Inspection .....	221	Diagnosis Procedure .....	247
<b>ABS WARNING LAMP .....</b>	<b>222</b>	<b>NORMAL OPERATING CONDITION .....</b>	<b>248</b>
Description .....	222	Description .....	248
Component Function Check .....	222	<b>PRECAUTION .....</b>	<b>249</b>
Diagnosis Procedure .....	222	<b>PRECAUTIONS .....</b>	<b>249</b>
<b>BRAKE WARNING LAMP .....</b>	<b>223</b>	Precaution for Supplemental Restraint System	
Description .....	223	(SRS) "AIR BAG" and "SEAT BELT PRE-TEN-	
Component Function Check .....	223	SIONER" .....	249
Diagnosis Procedure .....	223	Precaution for Brake System .....	249
<b>VDC OFF INDICATOR LAMP .....</b>	<b>224</b>	Precaution for Brake Control .....	249
Description .....	224	Precaution for CAN System .....	250
Component Function Check .....	224	<b>PREPARATION .....</b>	<b>251</b>
Diagnosis Procedure .....	224	<b>PREPARATION .....</b>	<b>251</b>
<b>SLIP INDICATOR LAMP .....</b>	<b>225</b>	Special Service Tool .....	251
Description .....	225	Commercial Service Tool .....	252
Component Function Check .....	225	<b>REMOVAL AND INSTALLATION .....</b>	<b>253</b>
Diagnosis Procedure .....	225	<b>WHEEL SENSORS .....</b>	<b>253</b>
<b>ECU DIAGNOSIS .....</b>	<b>226</b>	Removal and Installation .....	253
<b>ABS ACTUATOR AND ELECTRIC UNIT</b>		<b>SENSOR ROTOR .....</b>	<b>254</b>
<b>(CONTROL UNIT) .....</b>	<b>226</b>	Removal and Installation .....	254
Reference Value .....	226	<b>ACTUATOR AND ELECTRIC UNIT (ASSEM-</b>	
Wiring Diagram .....	231	<b>BLY) .....</b>	<b>255</b>
Fail-Safe .....	238	Removal and Installation .....	255
DTC No. Index .....	239	<b>STEERING ANGLE SENSOR .....</b>	<b>257</b>
<b>SYMPTOM DIAGNOSIS .....</b>	<b>241</b>	Removal and Installation .....	257
<b>VDC/TCS/ABS .....</b>	<b>241</b>	<b>G SENSOR .....</b>	<b>258</b>
Symptom Table .....	241	Removal and Installation .....	258
<b>EXCESSIVE ABS FUNCTION OPERATION</b>			
<b>FREQUENCY .....</b>	<b>242</b>		
Diagnosis Procedure .....	242		

## BASIC INSPECTION

### DIAGNOSIS AND REPAIR WORKFLOW

Work Flow

INFOID:000000001600828

#### OVERALL SEQUENCE

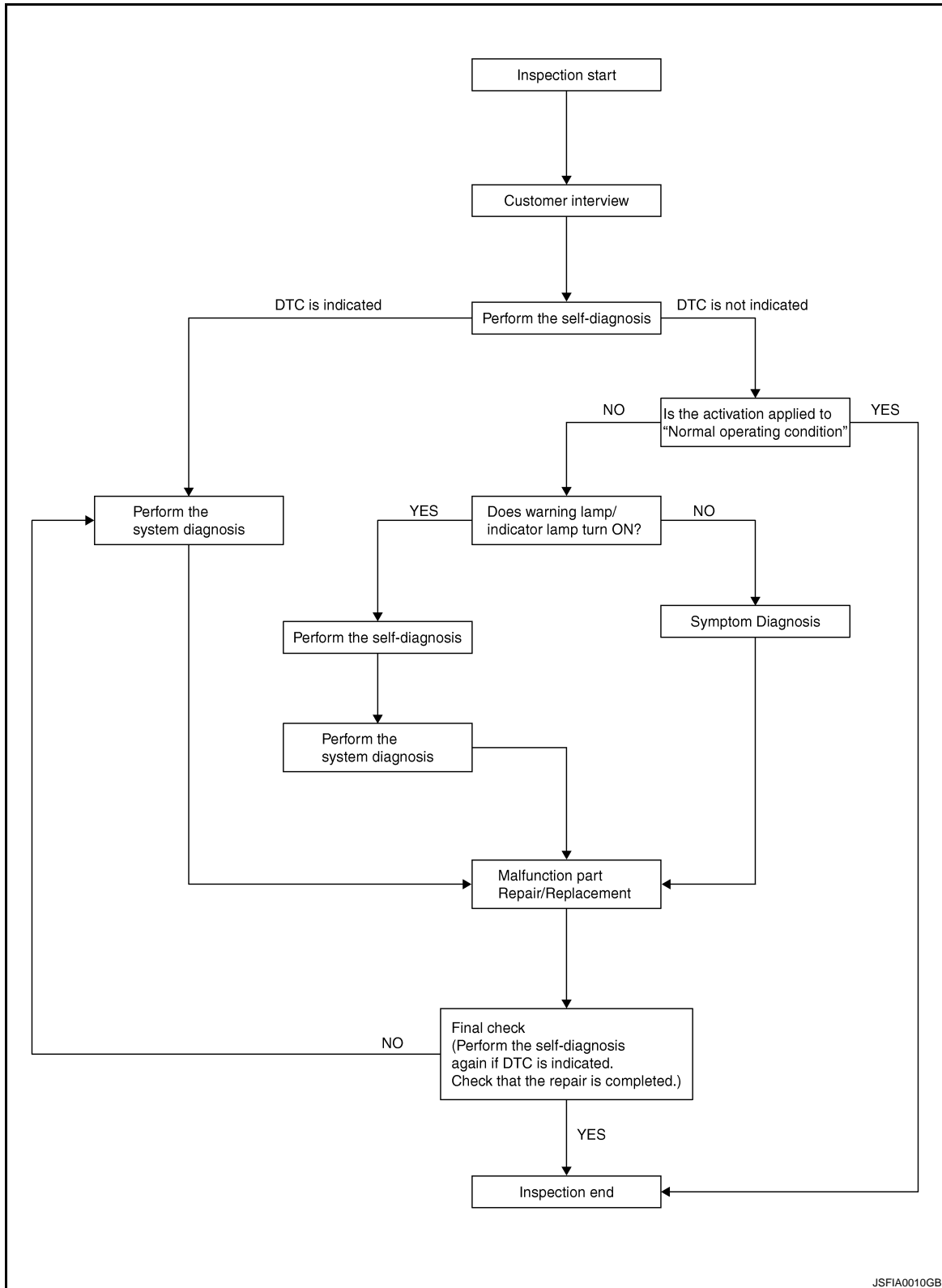

DETAILED FLOW

A  
B  
C  
D  
E  
BRC  
G  
H  
I  
J  
K  
L  
M  
N  
O  
P

# DIAGNOSIS AND REPAIR WORKFLOW

[ABS]

< BASIC INSPECTION >

---

## 1. COLLECT THE INFORMATION FROM THE CUSTOMER

---

Get the detailed information from the customer about the symptom (the condition and the environment when the incident/malfunction occurred) using the diagnosis worksheet. Refer to [BRC-9, "Diagnostic Work Sheet"](#).

>> GO TO 2

---

## 2. PERFORM THE SELF-DIAGNOSIS

---

Check the DTC display with the self-diagnosis function. Refer to [BRC-16, "CONSULT-III Function \(ABS\)"](#).

Is there any DTC displayed?

YES >> GO TO 3

NO >> GO TO 4

---

## 3. PERFORM THE SYSTEM DIAGNOSIS

---

Perform the diagnosis applicable to the displayed DTC. Refer to [BRC-51, "DTC No. Index"](#).

>> GO TO 7

---

## 4. CHECK THE SYMPTOM THAT IS NOT CONSIDERED A SYSTEM MALFUNCTION

---

Check that the symptom is a normal operation that is not considered a system malfunction. Refer to [BRC-58, "Description"](#).

Is the symptom a normal operation?

YES >> INSPECTION END

NO >> GO TO 5

---

## 5. CHECK THE WARNING LAMP AND INDICATOR LAMP FOR ILLUMINATION

---

Check that the warning lamp and indicator lamp illuminate.

- ABS warning lamp: Refer to [BRC-41, "Description"](#).
- Brake warning lamp: Refer to [BRC-42, "Description"](#).

Is ON/OFF timing normal?

YES >> GO TO 6

NO >> GO TO 2

---

## 6. PERFORM THE DIAGNOSIS BY SYMPTOM

---

Perform the diagnosis applicable to the symptom.

>> GO TO 7

---

## 7. REPAIR OR REPLACE THE MALFUNCTIONING PARTS

---

Repair or replace the specified malfunctioning parts.

>> GO TO 8

---

## 8. FINAL CHECK

---

Perform the self-diagnosis again, and check that the malfunction is repaired completely. After checking, erase the self-diagnosis memory. Refer to [BRC-16, "CONSULT-III Function \(ABS\)"](#).

Is no other DTC present and the repair completed?

YES >> INSPECTION END

NO >> GO TO 3



# DIAGNOSIS AND REPAIR WORKFLOW

< BASIC INSPECTION >

[ABS]

## Diagnostic Work Sheet

INFOID:000000001600829

Customer name	Model & Year	VIN	
Engine #	Trans.	Mileage	
Incident Date	Manuf. Date	In Service Date	
Symptoms	<input type="checkbox"/> Noise and vibration (from engine compartment) <input type="checkbox"/> Noise and vibration (from axle)	<input type="checkbox"/> ABS warning lamp activates	<input type="checkbox"/> Pedal operation <input type="checkbox"/> Large stroke pedal operation <input type="checkbox"/> Firm pedal
	<input type="checkbox"/> ABS does not work (wheels lock when braking)	<input type="checkbox"/> ABS does not work (wheels slip when braking)	<input type="checkbox"/> Lack of sense of acceleration
Engine conditions	<input type="checkbox"/> When starting <input type="checkbox"/> After starting		
Road conditions	<input type="checkbox"/> Low friction road ( <input type="checkbox"/> Snow <input type="checkbox"/> Gravel <input type="checkbox"/> Other ) <input type="checkbox"/> Bumps/potholes		
Driving conditions	<input type="checkbox"/> Full-acceleration <input type="checkbox"/> High speed cornering <input type="checkbox"/> Vehicle speed: Greater than 10 km/h (6 MPH) <input type="checkbox"/> Vehicle speed: 10 km/h (6 MPH) or less <input type="checkbox"/> Vehicle is stopped		
Applying brake conditions	<input type="checkbox"/> Suddenly <input type="checkbox"/> Gradually		
Other conditions	<input type="checkbox"/> Operation of electrical equipment <input type="checkbox"/> Shift change <input type="checkbox"/> Other descriptions		

WFIA0226E

A  
B  
C  
D  
E  
BRC  
G  
H  
I  
J  
K  
L  
M  
N  
O  
P

# FUNCTION DIAGNOSIS

## ABS

### System Diagram

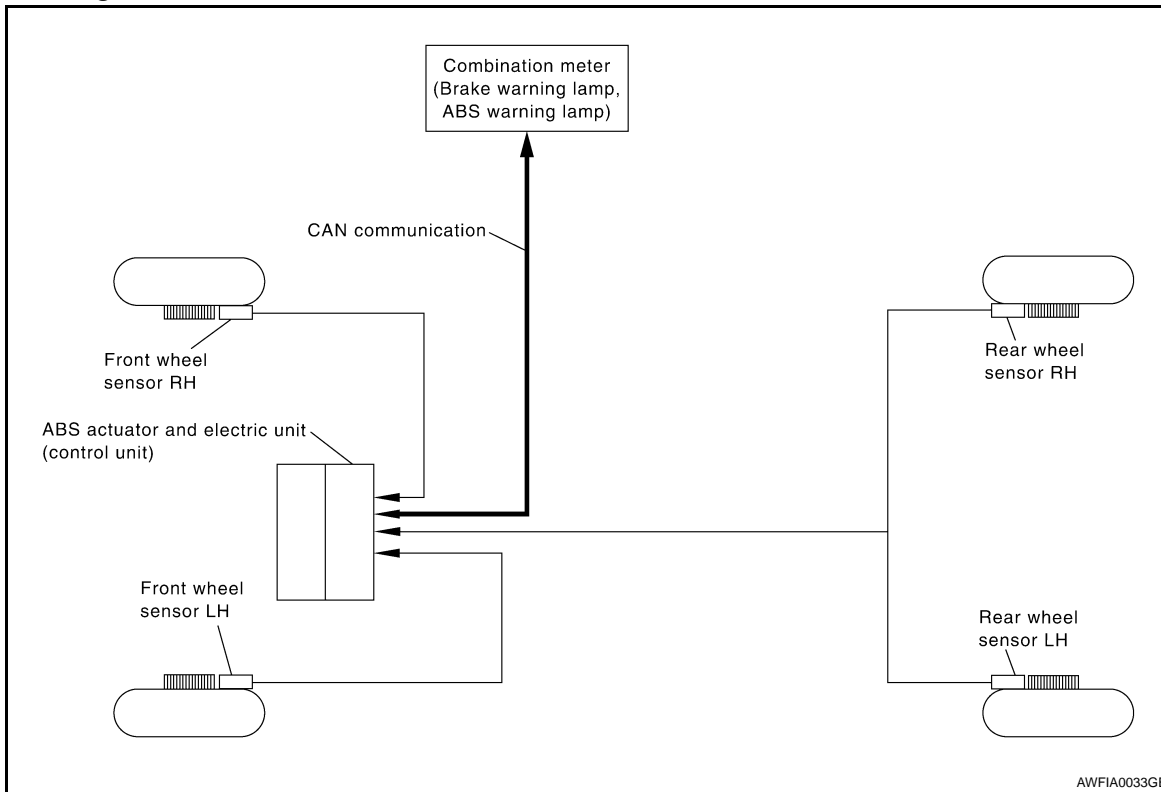

### System Description

INFOID:000000001600845

- Anti-Lock Braking System is a function that detects wheel revolution while braking, electronically controls braking force, and prevents wheel locking during sudden braking. It improves handling stability and maneuverability for avoiding obstacles.
- Electrical system diagnosis by CONSULT-III is available.

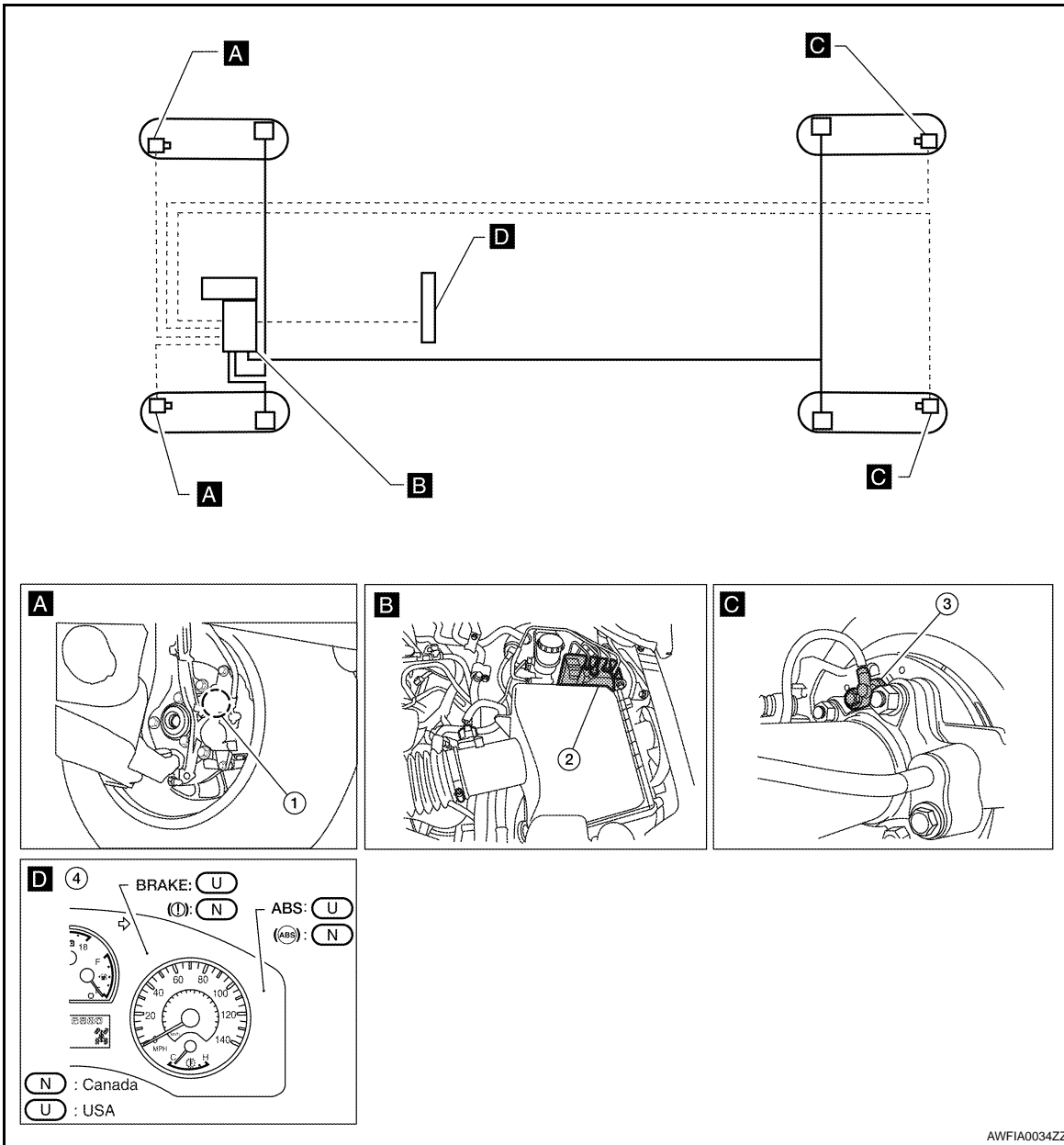

- 1. Front wheel sensor  
LH E18  
RH E117
- 2. ABS actuator and electric unit (control unit) E125
- 3. Rear wheel sensor  
LH C11  
RH C10
- 4. Combination meter M24, M25

Component Description

Component parts		Reference
ABS actuator and electric unit (control unit)	Pump	<a href="#">BRC-28, "Description"</a>
	Motor	
	Actuator relay	<a href="#">BRC-38, "Description"</a>
	Solenoid valve	<a href="#">BRC-34, "Description"</a>
Wheel sensor		<a href="#">BRC-19, "Description"</a>

# ABS

< FUNCTION DIAGNOSIS >

[ABS]

Component parts	Reference
ABS warning lamp	<a href="#">BRC-41. "Description"</a>
Brake warning lamp	<a href="#">BRC-42. "Description"</a>

EBD

System Diagram

INFOID:000000001674212

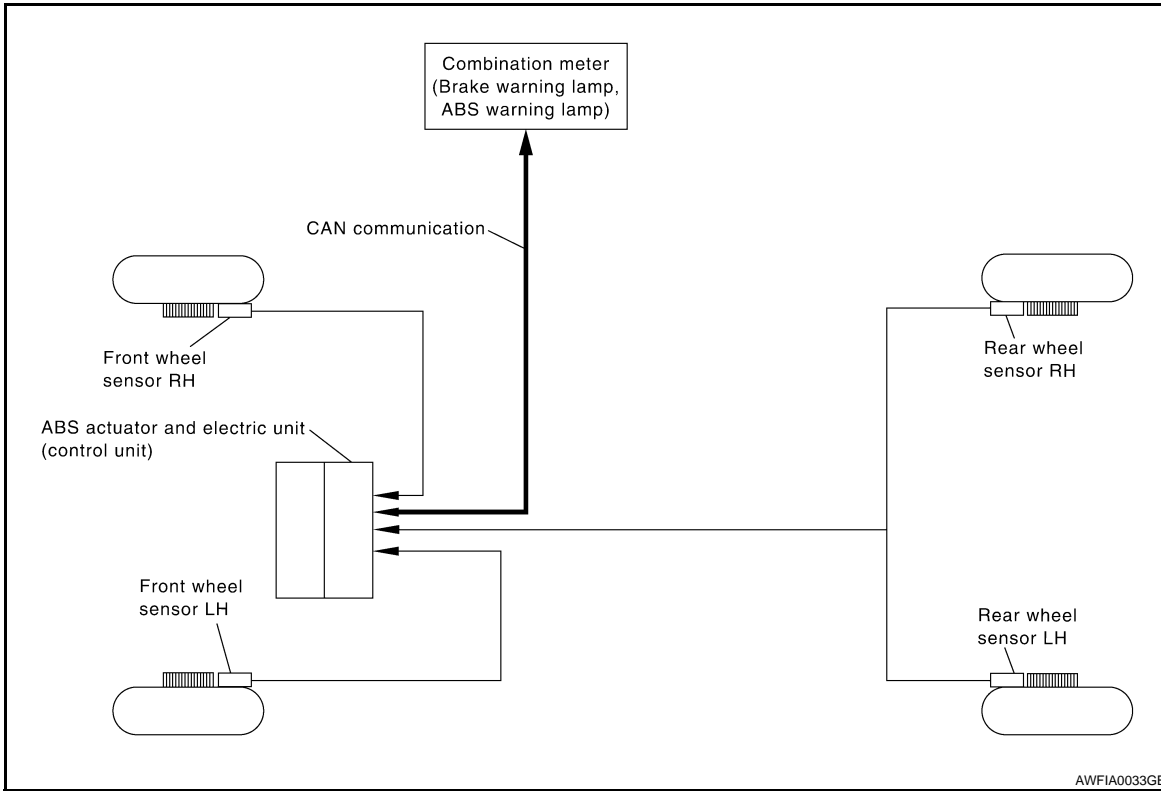

A  
B  
C  
D  
E  
BRC  
G  
H  
I  
J  
K  
L  
M  
N  
O  
P

System Description

INFOID:000000001600849

- Electric Brake force Distribution is a following function. ABS actuator and electric unit (control unit) detects subtle slippages between the front and rear wheels during braking. Then it electronically controls the rear braking force (brake fluid pressure) to reduce rear wheel slippage. Accordingly, it improves vehicle stability.
- Electrical system diagnosis by CONSULT-III is available.

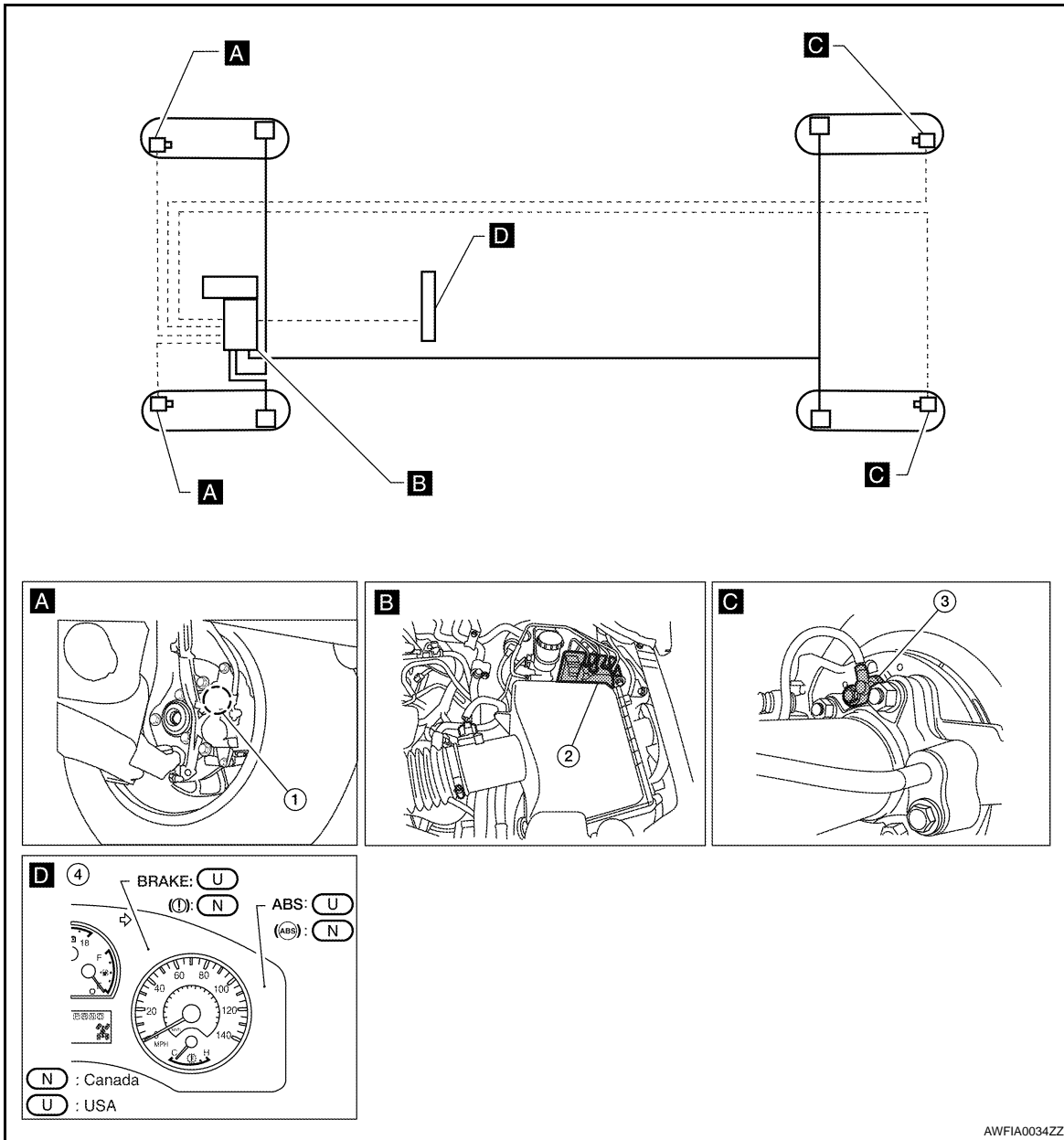

AWFIA0034ZZ

- 1. Front wheel sensor  
LH E18  
RH E117
- 2. ABS actuator and electric unit (control unit) E125
- 3. Rear wheel sensor  
LH C11  
RH C10
- 4. Combination meter M24, M25

Component Description

Component parts		Reference
ABS actuator and electric unit (control unit)	Pump	<a href="#">BRC-28. "Description"</a>
	Motor	
	Actuator relay	<a href="#">BRC-38. "Description"</a>
	Solenoid valve	<a href="#">BRC-34. "Description"</a>
Wheel sensor		<a href="#">BRC-19. "Description"</a>

# EBD

< FUNCTION DIAGNOSIS >

[ABS]

Component parts	Reference
ABS warning lamp	<a href="#">BRC-41, "Description"</a>
Brake warning lamp	<a href="#">BRC-42, "Description"</a>

A

B

C

D

E

**BRC**

G

H

I

J

K

L

M

N

O

P

# DIAGNOSIS SYSTEM [ABS ACTUATOR AND ELECTRIC UNIT (CONTROL UNIT)]

< FUNCTION DIAGNOSIS >

[ABS]

## DIAGNOSIS SYSTEM [ABS ACTUATOR AND ELECTRIC UNIT (CONTROL UNIT)]

### CONSULT-III Function (ABS)

INFOID:000000001600852

#### FUNCTION

CONSULT-III can display each diagnostic item using the diagnostic test modes shown following.

Diagnostic test mode	Function
Work support	This mode enables a technician to adjust some devices faster and more accurately by following the indications on CONSULT-III.
Self-diagnostic results	Self-diagnostic results can be read and erased quickly.
Data monitor	Input/Output data in the ABS actuator and electric unit (control unit) can be read.
Active test	Diagnostic test mode is which CONSULT-III drives some actuators apart from the ABS actuator and electric unit (control unit) and also shifts some parameters in a specified range.
ECU part number	ABS actuator and electric unit (control unit) part number can be read.
CAN diagnostic support monitor	The results of transmit/receive diagnosis of CAN communication can be read.

#### SELF-DIAG RESULTS MODE

##### Operation Procedure

1. Before performing the self-diagnosis, start engine and drive vehicle at 30 km/h (19 MPH) or more for approximately 1 minute.

##### How to Erase Self-diagnosis Results

1. After erasing DTC memory, start engine and drive vehicle at 30 km/h (19 MPH) or more for approximately 1 minute as the final inspection, and make sure that the ABS warning lamp and brake warning lamp turn OFF.

**CAUTION:**

**If memory cannot be erased, perform applicable diagnosis.**

**NOTE:**

- When the wheel sensor malfunctions, after inspecting the wheel sensor system, the ABS warning lamp and brake warning lamp will not turn OFF even when the system is normal unless the vehicle is driving at approximately 30 km/h (19 MPH) or more for approximately 1 minute.
- Brake warning lamp will turn ON in case of parking brake operation (when switch is ON) or of brake fluid level switch operation (when brake fluid is insufficient).

##### Display Item List

Refer to [BRC-51, "DTC No. Index"](#).

#### DATA MONITOR MODE

##### Display Item List

Item (Unit)	Data monitor item selection			Remarks
	ECU INPUT SIGNALS	MAIN SIGNALS	SELECTION FROM MENU	
FR RH SENSOR (km/h, MPH)	×	×	×	Wheel speed calculated by front RH wheel sensor signal is displayed.
FR LH SENSOR (km/h, MPH)	×	×	×	Wheel speed calculated by front LH wheel sensor signal is displayed.
RR RH SENSOR (km/h, MPH)	×	×	×	Wheel speed calculated by rear RH wheel sensor signal is displayed.
RR LH SENSOR (km/h, MPH)	×	×	×	Wheel speed calculated by rear LH wheel sensor signal is displayed.
BATTERY VOLT (V)	×	×	×	Voltage supplied to ABS actuator and electric unit (control unit) is displayed.



# DIAGNOSIS SYSTEM [ABS ACTUATOR AND ELECTRIC UNIT (CONTROL UNIT)]

< FUNCTION DIAGNOSIS >

[ABS]

Item (Unit)	Data monitor item selection			Remarks
	ECU INPUT SIGNALS	MAIN SIGNALS	SELECTION FROM MENU	
STOP LAMP SW (ON/OFF)	×	×	×	Stop lamp switch (ON/OFF) status is displayed.
ABS WARN LAMP (ON/OFF)	-	×	×	ABS warning lamp (ON/OFF) status is displayed.
FR LH IN SOL (ON/OFF)	-	×	×	Front LH IN ABS solenoid (ON/OFF) status is displayed.
FR LH OUT SOL (ON/OFF)	-	×	×	Front LH OUT ABS solenoid (ON/OFF) status is displayed.
REAR IN SOL (ON/OFF)	-	×	×	Rear IN ABS solenoid (ON/OFF) status is displayed.
REAR OUT SOL (ON/OFF)	-	×	×	Rear OUT ABS solenoid (ON/OFF) status is displayed.
FR RH IN SOL (ON/OFF)	-	×	×	Front RH IN ABS solenoid (ON/OFF) status is displayed.
FR RH OUT SOL (ON/OFF)	-	×	×	Front RH OUT ABS solenoid (ON/OFF) status is displayed.
MOTOR RELAY (ON/OFF)	-	×	×	ABS motor relay signal (ON/OFF) status is displayed.
ACTUATOR RLY (ON/OFF)	-	×	×	ABS actuator relay signal (ON/OFF) status is displayed.
ABS FAIL SIG (ON/OFF)	-	-	×	ABS fail signal (ON/OFF) status is displayed.
EBD FAIL SIG (ON/OFF)	-	-	×	EBD fail signal (ON/OFF) status is displayed.
EBD SIGNAL (ON/OFF)	-	-	×	EBD operation (ON/OFF) status is displayed.
ABS SIGNAL (ON/OFF)	-	-	×	ABS operation (ON/OFF) status is displayed.

×: Applicable

-: Not applicable

## ACTIVE TEST

### CAUTION:

- Do not perform active test while driving.
- Make sure to completely bleed air from the brake system.
- The ABS and brake warning lamps turn on during the active test.

### Solenoid Valve Operation Chart

Operation		ABS solenoid valve			ABS solenoid valve (ACT)		
		UP	KEEP	DOWN	UP	ACTUA-TOR UP	ACTUA-TOR KEEP
FR RH SOL FR RH ABS SOLE- NOID (ACT)	FR RH IN SOL	OFF	ON	ON	OFF	OFF	OFF
	FR RH OUT SOL	OFF	OFF	ON*	OFF	OFF	OFF
FR LH SOL FR LH ABS SOLE- NOID (ACT)	FR LH IN SOL	OFF	ON	ON	OFF	OFF	OFF
	FR LH OUT SOL	OFF	OFF	ON*	OFF	OFF	OFF
REAR SOL	REAR IN SOL	OFF	ON	ON	OFF	OFF	OFF
	REAR OUT SOL	OFF	OFF	ON*	OFF	OFF	OFF

\*: ON for 1 to 2 seconds after the touch, and then OFF

### NOTE:

- If active test is performed with brake pedal depressed, pedal stroke may change. This is normal.

# DIAGNOSIS SYSTEM [ABS ACTUATOR AND ELECTRIC UNIT (CONTROL UNIT)]

< FUNCTION DIAGNOSIS >

[ABS]

- “TEST IS STOPPED” is displayed approximately 10 seconds after operation starts.
- After “TEST IS STOPPED” is displayed, to perform test again, repeat Step 6.

ABS Motor

Touch “ON” and “OFF” on the screen. Check that ABS motor relay operates as shown in table below.

Operation	ON	OFF
ABS actuator relay	ON	ON
ABS motor relay	ON	OFF

**NOTE:**

- If active test is performed with brake pedal depressed, pedal stroke may change. This is normal.
- “TEST IS STOPPED” is displayed approximately 10 seconds after operation starts.

# C1101, C1102, C1103, C1104 WHEEL SENSOR-1

[ABS]

< COMPONENT DIAGNOSIS >

## COMPONENT DIAGNOSIS

### C1101, C1102, C1103, C1104 WHEEL SENSOR-1

#### Description

INFOID:000000001600853

When the sensor rotor rotates, the magnetic field changes. It converts the magnetic field changes to current signals (rectangular wave) and transmits them to the ABS actuator and electric unit (control unit).

#### DTC Logic

INFOID:000000001600854

#### DTC DETECTION LOGIC

DTC	Display item	Malfunction detected condition	Possible cause
C1101	RR RH SENSOR-1	Circuit of rear RH wheel sensor is open. Or when the sensor power voltage is outside the standard.	<ul style="list-style-type: none"><li>• Harness or connector</li><li>• Wheel sensor</li><li>• ABS actuator and electric unit (control unit)</li></ul>
C1102	RR LH SENSOR-1	Circuit of rear LH wheel sensor is open. Or when the sensor power voltage is outside the standard.	
C1103	FR RH SENSOR-1	Circuit of front RH wheel sensor is open. Or when the sensor power voltage is outside the standard.	
C1104	FR LH SENSOR-1	Circuit of front LH wheel sensor is open. Or when the sensor power voltage is outside the standard.	

#### DTC CONFIRMATION PROCEDURE

##### 1. CHECK SELF-DIAGNOSIS RESULTS

Check the self-diagnosis results.

Self-diagnosis results
RR RH SENSOR-1
RR LH SENSOR-1
FR RH SENSOR-1
FR LH SENSOR-1

Is above displayed on the self-diagnosis display?

- YES >> Proceed to diagnosis procedure. Refer to [BRC-19. "Diagnosis Procedure"](#).  
NO >> INSPECTION END

#### Diagnosis Procedure

INFOID:000000001600855

#### CAUTION:

Do not check between wheel sensor terminals.

#### INSPECTION PROCEDURE

##### 1. CONNECTOR INSPECTION

Disconnect the ABS actuator and electric unit (control unit) connector E125 and wheel sensor of malfunctioning code.

Check the terminals for deformation, disconnection, looseness or damage.

Is the inspection result normal?

- YES >> GO TO 2  
NO >> Repair or replace as necessary.

##### 2. CHECK WHEEL SENSOR OUTPUT SIGNAL

1. Connect ABS active wheel sensor tester (J-45741) to wheel sensor using appropriate adapter.
2. Turn on the ABS active wheel sensor tester power switch.

#### NOTE:

The green POWER indicator should illuminate. If the POWER indicator does not illuminate, replace the battery in the ABS active wheel sensor tester before proceeding.

# C1101, C1102, C1103, C1104 WHEEL SENSOR-1

[ABS]

## < COMPONENT DIAGNOSIS >

- Spin the wheel of the vehicle by hand and observe the red SENSOR indicator on the ABS active wheel sensor tester. The red SENSOR indicator should flash on and off to indicate an output signal.

**NOTE:**

If the red SENSOR indicator illuminates but does not flash, reverse the polarity of the tester leads and retest.

Does the ABS active wheel sensor tester detect a signal?

YES >> GO TO 3

NO >> Replace the wheel sensor. Refer to [BRC-62, "Removal and Installation"](#).

### 3.CHECK TIRES

Check for inflation pressure, wear and size of each tire.

Are tire pressure and size correct and is tire wear within specifications?

YES >> GO TO 4

NO >> Adjust tire pressure or replace tire(s).

### 4.CHECK WHEEL BEARINGS

Check wheel bearing axial end play. Refer to [FAX-5, "On-Vehicle Inspection and Service"](#) (front) or [RAX-5, "On-Vehicle Inspection"](#) (rear).

Is the inspection result normal?

YES >> GO TO 5

NO >> Repair or replace as necessary. Refer to [FAX-6, "Removal and Installation"](#) (front) or [RAX-7, "Removal and Installation"](#) (rear).

### 5.CHECK WIRING HARNESS FOR SHORT CIRCUIT

- Disconnect ABS actuator and electric unit (control unit) connector and wheel sensor connector of malfunction code No.
- Check continuity between wheel sensor harness connector terminals and ground.

**Continuity should not exist.**

Is the inspection result normal?

YES >> GO TO 6

NO >> Repair the circuit.

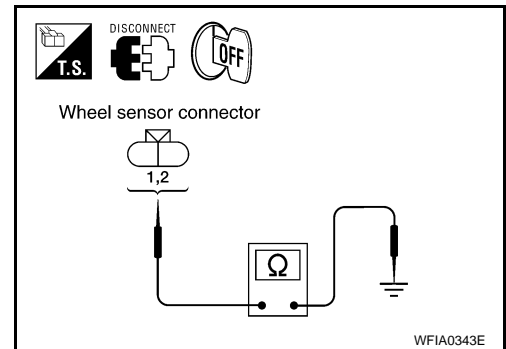

### 6.CHECK WIRING HARNESS FOR OPEN CIRCUIT

- Check continuity between ABS actuator and electric unit (control unit) harness connector E125 and the malfunctioning wheel sensor harness connector E18, E117, C10, or C11.

Wheel sensor	ABS actuator and electric unit (control unit)		Wheel sensor		Continuity
	Connector	Terminal	Connector	Terminal	
Front LH	E125	45	E18	1	Yes
		46		2	
Front RH		34	E117	1	
		33		2	
Rear LH		37	C11	2	
		36		1	
Rear RH		42	C10	2	
		43		1	

Is the inspection result normal?

YES >> Replace the ABS actuator and electric unit (control unit). Refer to [BRC-64, "Removal and Installation"](#).

NO >> Repair the circuit.

# C1101, C1102, C1103, C1104 WHEEL SENSOR-1

< COMPONENT DIAGNOSIS >

[ABS]

## Component Inspection

INFOID:000000001600856

### 1. CHECK DATA MONITOR

On "DATA MONITOR", select "FR LH SENSOR", "FR RH SENSOR", "RR LH SENSOR", and "RR RH SENSOR", and check the vehicle speed.

Wheel sensor	Vehicle speed (DATA MONITOR)
FR LH SENSOR	Nearly matches the speedometer display ( $\pm 10\%$ or less)
FR RH SENSOR	
RR LH SENSOR	
RR RH SENSOR	

Is the inspection result normal?

YES >> INSPECTION END

NO >> Go to diagnosis procedure. Refer to [BRC-19. "Diagnosis Procedure"](#).

A  
B  
C  
D  
E  
G  
H  
I  
J  
K  
L  
M  
N  
O  
P

**BRC**

# C1105, C1106, C1107, C1108 WHEEL SENSOR-2

< COMPONENT DIAGNOSIS >

[ABS]

## C1105, C1106, C1107, C1108 WHEEL SENSOR-2

### Description

INFOID:000000001674215

When the sensor rotor rotates, the magnetic field changes. It converts the magnetic field changes to current signals (rectangular wave) and transmits them to the ABS actuator and electric unit (control unit).

### DTC Logic

INFOID:000000001600859

### DTC DETECTION LOGIC

DTC	Display item	Malfunction detected condition	Possible cause
C1105	RR RH SENSOR-2	When the circuit in the rear RH wheel sensor is short-circuited. Or when the distance between the wheel sensor and sensor rotor is too large and the sensor pulse cannot be recognized by the control unit.	<ul style="list-style-type: none"><li>• Harness or connector</li><li>• Wheel sensor</li><li>• ABS actuator and electric unit (control unit)</li></ul>
C1106	RR LH SENSOR-2	When the circuit in the rear LH wheel sensor is short-circuited. Or when the distance between the wheel sensor and sensor rotor is too large and the sensor pulse cannot be recognized by the control unit.	
C1107	FR RH SENSOR-2	When the circuit in the front RH wheel sensor is short-circuited. Or when the distance between the wheel sensor and sensor rotor is too large and the sensor pulse cannot be recognized by the control unit.	
C1108	FR LH SENSOR-2	When the circuit in the front LH wheel sensor is short-circuited. Or when the distance between the wheel sensor and sensor rotor is too large and the sensor pulse cannot be recognized by the control unit.	

### DTC CONFIRMATION PROCEDURE

#### 1. CHECK SELF-DIAGNOSIS RESULTS

Check the self-diagnosis results.

Self-diagnosis results
RR RH SENSOR-2
RR LH SENSOR-2
FR RH SENSOR-2
FR LH SENSOR-2

Is above displayed on the self-diagnosis display?

YES >> Proceed to diagnosis procedure. Refer to [BRC-22. "Diagnosis Procedure"](#).

NO >> INSPECTION END

### Diagnosis Procedure

INFOID:000000001674216

#### **CAUTION:**

**Do not check between wheel sensor terminals.**

### INSPECTION PROCEDURE

#### 1. CONNECTOR INSPECTION

Disconnect the ABS actuator and electric unit (control unit) connector E125 and wheel sensor of malfunctioning code.

Check the terminals for deformation, disconnection, looseness or damage.

Is the inspection result normal?

YES >> GO TO 2

NO >> Repair or replace as necessary.

# C1105, C1106, C1107, C1108 WHEEL SENSOR-2

< COMPONENT DIAGNOSIS >

[ABS]

## 2. CHECK WHEEL SENSOR OUTPUT SIGNAL

1. Connect ABS active wheel sensor tester (J-45741) to wheel sensor using appropriate adapter.
2. Turn on the ABS active wheel sensor tester power switch.

**NOTE:**

The green POWER indicator should illuminate. If the POWER indicator does not illuminate, replace the battery in the ABS active wheel sensor tester before proceeding.

3. Spin the wheel of the vehicle by hand and observe the red SENSOR indicator on the ABS active wheel sensor tester. The red SENSOR indicator should flash on and off to indicate an output signal.

**NOTE:**

If the red SENSOR indicator illuminates but does not flash, reverse the polarity of the tester leads and retest.

Does the ABS active wheel sensor tester detect a signal?

YES >> GO TO 3

NO >> Replace the wheel sensor. Refer to [BRC-62. "Removal and Installation"](#).

## 3. CHECK TIRES

Check for inflation pressure, wear and size of each tire.

Are tire pressure and size correct and is tire wear within specifications?

YES >> GO TO 4

NO >> Adjust tire pressure or replace tire(s).

## 4. CHECK WHEEL BEARINGS

Check wheel bearing axial end play. Refer to [FAX-5. "On-Vehicle Inspection and Service"](#) (front) or [RAX-5. "On-Vehicle Inspection"](#) (rear).

Is the inspection result normal?

YES >> GO TO 5

NO >> Repair or replace as necessary. Refer to [FAX-6. "Removal and Installation"](#) (front) or [RAX-7. "Removal and Installation"](#) (rear).

## 5. CHECK WIRING HARNESS FOR SHORT CIRCUIT

1. Disconnect ABS actuator and electric unit (control unit) connector and wheel sensor connector of malfunction code No.
2. Check continuity between wheel sensor harness connector terminals and ground.

**Continuity should not exist.**

Is the inspection result normal?

YES >> GO TO 6

NO >> Repair the circuit.

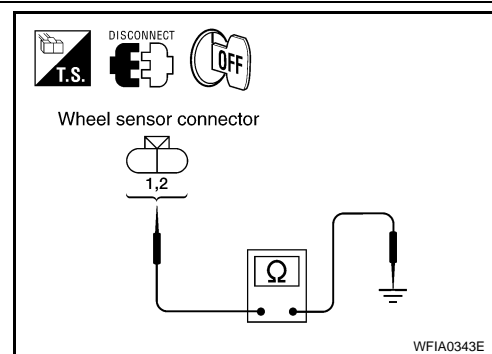

## 6. CHECK WIRING HARNESS FOR OPEN CIRCUIT

1. Check continuity between ABS actuator and electric unit (control unit) harness connector E125 and the malfunctioning wheel sensor harness connector E18, E117, C10, or C11.

# C1105, C1106, C1107, C1108 WHEEL SENSOR-2

< COMPONENT DIAGNOSIS >

[ABS]

Wheel sensor	ABS actuator and electric unit (control unit)		Wheel sensor		Continuity
	Connector	Terminal	Connector	Terminal	
Front LH	E125	45	E18	1	Yes
		46		2	
Front RH		34	E117	1	
		33		2	
Rear LH		37	C11	2	
		36		1	
Rear RH		42	C10	2	
		43		1	

Is the inspection result normal?

YES >> Replace the ABS actuator and electric unit (control unit). Refer to [BRC-64, "Removal and Installation"](#).

NO >> Repair the circuit.

## Component Inspection

INFOID:000000001674217

### 1. CHECK DATA MONITOR

On "DATA MONITOR", select "FR LH SENSOR", "FR RH SENSOR", "RR LH SENSOR", and "RR RH SENSOR", and check the vehicle speed.

Wheel sensor	Vehicle speed (DATA MONITOR)
FR LH SENSOR	Nearly matches the speedometer display ( $\pm 10\%$ or less)
FR RH SENSOR	
RR LH SENSOR	
RR RH SENSOR	

Is the inspection result normal?

YES >> INSPECTION END

NO >> Go to diagnosis procedure. Refer to [BRC-22, "Diagnosis Procedure"](#).



# C1109 POWER AND GROUND SYSTEM

[ABS]

< COMPONENT DIAGNOSIS >

## C1109 POWER AND GROUND SYSTEM

### Description

INFOID:000000001600863

Supplies electric power to the ABS actuator and electric unit (control unit).

### DTC Logic

INFOID:000000001600864

### DTC DETECTION LOGIC

DTC	Display item	Malfunction detected condition	Possible cause
C1109	BATTERY VOLTAGE [ABNORMAL]	When the ABS actuator and electric unit (control unit) power supply voltage is lower than normal.	<ul style="list-style-type: none"> <li>• Harness or connector</li> <li>• ABS actuator and electric unit (control unit)</li> </ul>

### DTC CONFIRMATION PROCEDURE

#### 1. CHECK SELF-DIAGNOSIS RESULTS

Check the self-diagnosis results.

Self-diagnosis results
BATTERY VOLTAGE [ABNORMAL]

Is above displayed on the self-diagnosis display?

- YES >> Proceed to diagnosis procedure. Refer to [BRC-25, "Diagnosis Procedure"](#).  
 NO >> INSPECTION END

### Diagnosis Procedure

INFOID:000000001600865

### INSPECTION PROCEDURE

#### 1. CHECK CONNECTOR

1. Turn ignition switch OFF.
2. Disconnect ABS actuator and electric unit (control unit) connector.
3. Check terminal for deformation, disconnection, looseness, and so on. If any malfunction is found, repair or replace terminal.
4. Reconnect connectors and then perform the self-diagnosis. Refer to [BRC-16, "CONSULT-III Function \(ABS\)"](#).

Is any item indicated on the self-diagnosis display?

- YES >> GO TO 2  
 NO >> Poor connection of connector terminal. Repair or replace connector.

#### 2. CHECK ABS ACTUATOR AND ELECTRIC UNIT (CONTROL UNIT) POWER SUPPLY CIRCUIT AND GROUND CIRCUIT

1. Turn ignition switch OFF.
2. Disconnect ABS actuator and electric unit (control unit) connector.
3. Turn ignition switch ON or OFF and check voltage between ABS actuator and electric unit (control unit) harness connector terminal and ground.

ABS actuator and electric unit (control unit)		—	Condition	Voltage
Connector	Terminal			
E125	4	Ground	Ignition switch: ON	Battery voltage
			Ignition switch: OFF	Approx. 0V

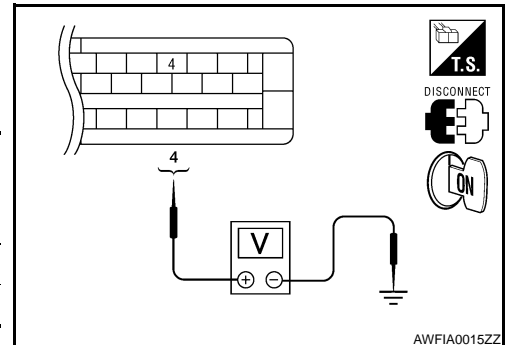

4. Turn ignition switch OFF.

# C1109 POWER AND GROUND SYSTEM

[ABS]

## < COMPONENT DIAGNOSIS >

5. Check continuity between ABS actuator and electric unit (control unit) harness connector terminals and ground.

ABS actuator and electric unit (control unit)		—	Continuity
Connector	Terminal		
E125	16, 47	Ground	Yes

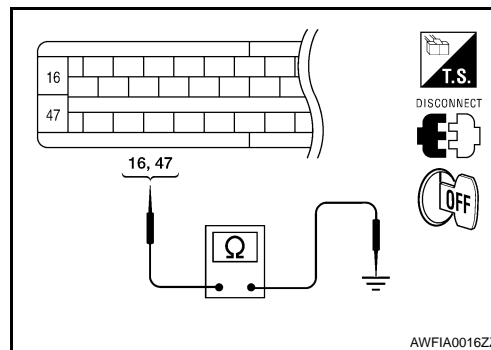

### Is the inspection result normal?

- YES >> Check battery for terminal looseness, low voltage, etc. If any malfunction is found, repair malfunctioning parts.
- NO >> Repair or replace malfunctioning components.

# C1110, C1113 ABS ACTUATOR AND ELECTRIC UNIT (CONTROL UNIT)

[ABS]

< COMPONENT DIAGNOSIS >

## C1110, C1113 ABS ACTUATOR AND ELECTRIC UNIT (CONTROL UNIT)

### DTC Logic

INFOID:000000001600867

### DTC DETECTION LOGIC

DTC	Display item	Malfunction detected condition	Possible cause
C1110	CONTROLLER FAILURE	When there is an internal malfunction in the ABS actuator and electric unit (control unit).	• ABS actuator and electric unit (control unit)
C1113	G-SENSOR	G-sensor is malfunctioning.	

### DTC CONFIRMATION PROCEDURE

#### 1. CHECK SELF-DIAGNOSIS RESULTS

Check the self-diagnosis results.

Self-diagnosis results
CONTROLLER FAILURE
G-SENSOR

Is above displayed on the self-diagnosis display?

- YES >> Proceed to diagnosis procedure. Refer to [BRC-27, "Diagnosis Procedure"](#).
- NO >> INSPECTION END

### Diagnosis Procedure

INFOID:000000001600868

### INSPECTION PROCEDURE

#### 1. REPLACE ABS ACTUATOR AND ELECTRIC UNIT (CONTROL UNIT)

- >> Replace ABS actuator and electric unit (control unit). Refer to [BRC-64, "Removal and Installation"](#).

# C1111 ABS MOTOR, MOTOR RELAY SYSTEM

< COMPONENT DIAGNOSIS >

[ABS]

## C1111 ABS MOTOR, MOTOR RELAY SYSTEM

### Description

INFOID:000000001600870

#### PUMP

The pump returns the brake fluid stored in the reservoir to the master cylinder by reducing the pressure.

#### MOTOR

The motor drives the pump according to the signals transmitted by the ABS actuator and electric unit (control unit).

### DTC Logic

INFOID:000000001600871

### DTC DETECTION LOGIC

DTC	Display item	Malfunction detected condition	Possible cause
C1111	PUMP MOTOR	During the actuator motor operating with ON, when the actuator motor turns OFF, or when the control line for actuator motor relay is open.	<ul style="list-style-type: none"><li>• Harness or connector</li><li>• ABS actuator and electric unit (control unit)</li></ul>
		During the actuator motor operating with OFF, when the actuator motor turns ON, or when the control line for relay is shorted to ground.	

### DTC CONFIRMATION PROCEDURE

#### 1. CHECK SELF-DIAGNOSIS RESULTS

Check the self-diagnosis results.

Self-diagnosis results

PUMP MOTOR

Is above displayed on the self-diagnosis display?

YES >> Proceed to diagnosis procedure. Refer to [BRC-28, "Diagnosis Procedure"](#).

NO >> INSPECTION END

### Diagnosis Procedure

INFOID:000000001600872

### INSPECTION PROCEDURE

#### 1. CHECK CONNECTOR

1. Turn ignition switch OFF.
2. Disconnect ABS actuator and electric unit (control unit) connector.
3. Check terminal for deformation, disconnect, looseness, and so on. If any malfunction is found, repair or replace terminal.
4. Reconnect connectors and then perform the self-diagnosis. Refer to [BRC-16, "CONSULT-III Function \(ABS\)"](#).

Is any item indicated on the self-diagnosis display?

YES >> GO TO 2

NO >> Poor connection of connector terminal. Repair or replace connector.

#### 2. CHECK ABS MOTOR AND MOTOR RELAY POWER SUPPLY CIRCUIT

# C1111 ABS MOTOR, MOTOR RELAY SYSTEM

[ABS]

## < COMPONENT DIAGNOSIS >

1. Turn ignition switch OFF.
2. Disconnect ABS actuator and electric unit (control unit) connector.
3. Check voltage between the ABS actuator and electric unit (control unit) harness connector terminal and ground.

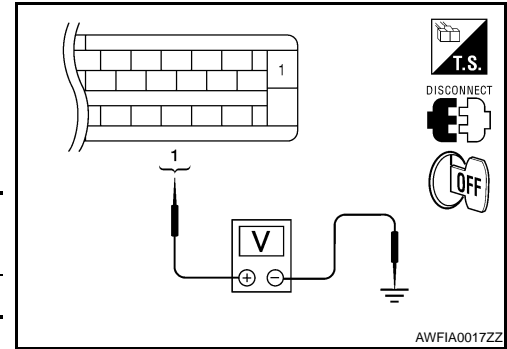

ABS actuator and electric unit (control unit)		—	Voltage
Connector	Terminal		
E125	1	Ground	Battery voltage

Is the inspection result normal?

- YES >> GO TO 3  
 NO >> Repair or replace malfunctioning components.

### 3.CHECK ABS ACTUATOR AND ELECTRIC UNIT (CONTROL UNIT) GROUND CIRCUIT

Check continuity between ABS actuator and electric unit (control unit) harness connector terminals and ground.

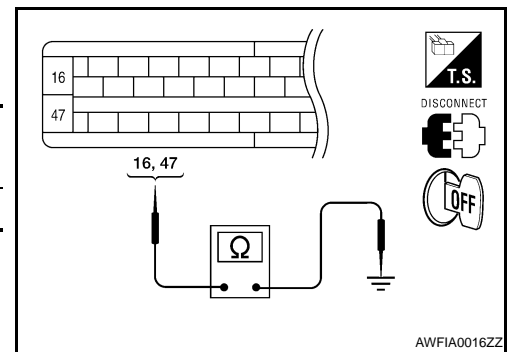

ABS actuator and electric unit (control unit)		—	Continuity
Connector	Terminal		
E125	16, 47	Ground	Yes

Is the inspection result normal?

- YES >> Replace ABS actuator and electric unit (control unit).  
 Refer to [BRC-64, "Removal and Installation"](#).  
 NO >> Repair or replace malfunctioning components.

## Component Inspection

INFOID:000000001600873

### 1.CHECK ACTIVE TEST

1. On "ACTIVE TEST", select "ABS MOTOR".
2. Touch ON and OFF on screen. Make sure motor relay and actuator relay operates as shown in table below.

Operation	ON	OFF
MOTOR RELAY	ON	OFF
ACTUATOR RLY	ON	ON

Is the inspection result normal?

- YES >> INSPECTION END  
 NO >> Go to diagnosis procedure. Refer to [BRC-28, "Diagnosis Procedure"](#).

A  
B  
C  
D  
E  
BRC  
G  
H  
I  
J  
K  
L  
M  
N  
O  
P

# C1115 WHEEL SENSOR

[ABS]

< COMPONENT DIAGNOSIS >

## C1115 WHEEL SENSOR

### Description

INFOID:000000001600880

When the sensor rotor rotates, the magnetic field changes. It converts the magnetic field changes to current signals (rectangular wave) and transmits them to the ABS actuator and electric unit (control unit).

### DTC Logic

INFOID:000000001600881

### DTC DETECTION LOGIC

DTC	Display item	Malfunction detected condition	Possible cause
C1115	ABS SENSOR [ABNORMAL SIGNAL]	When wheel sensor input signal is malfunctioning.	<ul style="list-style-type: none"><li>• Harness or connector</li><li>• Wheel sensor</li><li>• ABS actuator and electric unit (control unit)</li></ul>

### DTC CONFIRMATION PROCEDURE

#### 1. CHECK SELF-DIAGNOSIS RESULTS

Check the self-diagnosis results.

Self-diagnosis results
ABS SENSOR [ABNORMAL SIGNAL]

Is above displayed on the self-diagnosis display?

- YES >> Proceed to diagnosis procedure. Refer to [BRC-30, "Diagnosis Procedure"](#).  
NO >> INSPECTION END

### Diagnosis Procedure

INFOID:000000001674218

#### **CAUTION:**

**Do not check between wheel sensor terminals.**

### INSPECTION PROCEDURE

#### 1. CONNECTOR INSPECTION

Disconnect the ABS actuator and electric unit (control unit) connector E125 and wheel sensor of malfunctioning code.

Check the terminals for deformation, disconnection, looseness or damage.

Is the inspection result normal?

- YES >> GO TO 2  
NO >> Repair or replace as necessary.

#### 2. CHECK WHEEL SENSOR OUTPUT SIGNAL

1. Connect ABS active wheel sensor tester (J-45741) to wheel sensor using appropriate adapter.
2. Turn on the ABS active wheel sensor tester power switch.

##### **NOTE:**

The green POWER indicator should illuminate. If the POWER indicator does not illuminate, replace the battery in the ABS active wheel sensor tester before proceeding.

3. Spin the wheel of the vehicle by hand and observe the red SENSOR indicator on the ABS active wheel sensor tester. The red SENSOR indicator should flash on and off to indicate an output signal.

##### **NOTE:**

If the red SENSOR indicator illuminates but does not flash, reverse the polarity of the tester leads and retest.

Does the ABS active wheel sensor tester detect a signal?

- YES >> GO TO 3  
NO >> Replace the wheel sensor. Refer to [BRC-62, "Removal and Installation"](#).

#### 3. CHECK TIRES

# C1115 WHEEL SENSOR

[ABS]

## < COMPONENT DIAGNOSIS >

Check for inflation pressure, wear and size of each tire.

Are tire pressure and size correct and is tire wear within specifications?

- YES >> GO TO 4
- NO >> Adjust tire pressure or replace tire(s).

### 4.CHECK WHEEL BEARINGS

Check wheel bearing axial end play. Refer to [FAX-5, "On-Vehicle Inspection and Service"](#) (front) or [RAX-5, "On-Vehicle Inspection"](#) (rear).

Is the inspection result normal?

- YES >> GO TO 5
- NO >> Repair or replace as necessary. Refer to [FAX-6, "Removal and Installation"](#) (front) or [RAX-7, "Removal and Installation"](#) (rear).

### 5.CHECK WIRING HARNESS FOR SHORT CIRCUIT

1. Disconnect ABS actuator and electric unit (control unit) connector and wheel sensor connector of malfunction code No.
2. Check continuity between wheel sensor harness connector terminals and ground.

**Continuity should not exist.**

Is the inspection result normal?

- YES >> GO TO 6
- NO >> Repair the circuit.

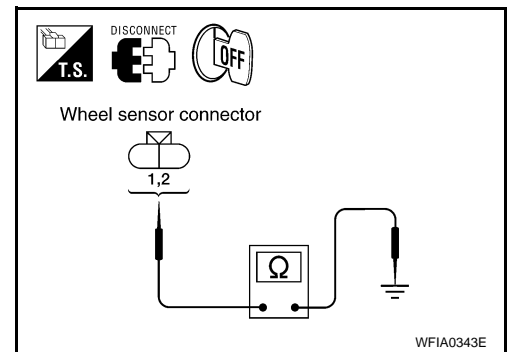

### 6.CHECK WIRING HARNESS FOR OPEN CIRCUIT

1. Check continuity between ABS actuator and electric unit (control unit) harness connector E125 and the malfunctioning wheel sensor harness connector E18, E117, C10, or C11.

Wheel sensor	ABS actuator and electric unit (control unit)		Wheel sensor		Continuity
	Connector	Terminal	Connector	Terminal	
Front LH	E125	45	E18	1	Yes
		46		2	
Front RH		34	E117	1	
		33		2	
Rear LH		37	C11	2	
		36		1	
Rear RH		42	C10	2	
		43		1	

Is the inspection result normal?

- YES >> Replace the ABS actuator and electric unit (control unit). Refer to [BRC-64, "Removal and Installation"](#).
- NO >> Repair the circuit.

## Component Inspection

INFOID:000000001674219

### 1.CHECK DATA MONITOR

On "DATA MONITOR", select "FR LH SENSOR", "FR RH SENSOR", "RR LH SENSOR", and "RR RH SENSOR", and check the vehicle speed.

Wheel sensor	Vehicle speed (DATA MONITOR)
--------------	------------------------------

# C1115 WHEEL SENSOR

[ABS]

< COMPONENT DIAGNOSIS >

FR LH SENSOR	Nearly matches the speedometer display ( $\pm 10\%$ or less)
FR RH SENSOR	
RR LH SENSOR	
RR RH SENSOR	

Is the inspection result normal?

YES >> INSPECTION END

NO >> Go to diagnosis procedure. Refer to [BRC-30. "Diagnosis Procedure"](#).



# C1116 STOP LAMP SWITCH

[ABS]

< COMPONENT DIAGNOSIS >

## C1116 STOP LAMP SWITCH

### Description

INFOID:000000001600885

The stop lamp switch transmits the stop lamp switch signal (ON/OFF) to the ABS actuator and electric unit (control unit).

### DTC Logic

INFOID:000000001600886

### DTC DETECTION LOGIC

DTC	Display item	Malfunction detected condition	Possible cause
C1116	STOP LAMP SW	When stop lamp switch circuit is open.	<ul style="list-style-type: none"><li>• Harness or connector</li><li>• Stop lamp switch</li><li>• ABS actuator and electric unit (control unit)</li></ul>

### DTC CONFIRMATION PROCEDURE

#### 1. CHECK SELF-DIAGNOSIS RESULTS

Check the self-diagnosis results.

Self-diagnosis results
STOP LAMP SW

Is above displayed on the self-diagnosis display?

- YES >> Proceed to diagnosis procedure. Refer to [BRC-33, "Diagnosis Procedure"](#).  
NO >> INSPECTION END

### Diagnosis Procedure

INFOID:000000001600887

### INSPECTION PROCEDURE

#### 1. CONNECTOR INSPECTION

1. Disconnect the ABS actuator and electric unit (control unit) connector E125 and stop lamp switch connector E38.
2. Check the terminals for deformation, disconnection, looseness or damage.

Is the inspection result normal?

- YES >> GO TO 2  
NO >> Repair or replace as necessary.

#### 2. STOP LAMP SWITCH INSPECTION

Check the voltage between the ABS actuator and electric unit (control unit) harness connector E125 terminal 41 and body ground.

**Brake pedal depressed : Battery voltage (approx. 12V)**

**Brake pedal not depressed : Approx. 0V**

Is the inspection result normal?

- YES >> Perform self-diagnosis again. If the same results appear, replace ABS actuator and electric unit (control unit). Refer to [BRC-64, "Removal and Installation"](#).  
NO >> Refer to [EXL-3, "Work Flow"](#).

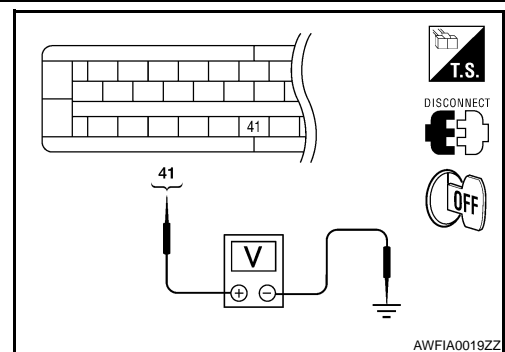

# C1120, C1122, C1190 IN ABS SOL

< COMPONENT DIAGNOSIS >

[ABS]

## C1120, C1122, C1190 IN ABS SOL

### Description

INFOID:000000001600889

The solenoid valve increases, holds or decreases the fluid pressure of each brake caliper according to the signals transmitted by the ABS actuator and electric unit (control unit).

### DTC Logic

INFOID:000000001600890

### DTC DETECTION LOGIC

DTC	Display item	Malfunction detected condition	Possible cause
C1120	FR LH IN ABS SOL	When the control unit detects a malfunction in the front LH inlet solenoid circuit.	• ABS actuator and electric unit (control unit)
C1122	FR RH IN ABS SOL	When the control unit detects a malfunction in the front RH inlet solenoid circuit.	
C1190	R-EV	When the control unit detects a malfunction in the rear inlet solenoid circuit.	

### DTC CONFIRMATION PROCEDURE

#### 1. CHECK SELF-DIAGNOSIS RESULTS

Check the self-diagnosis results.

Self-diagnosis results
FR LH IN ABS SOL
FR RH IN ABS SOL
R-EV

Is above displayed on the self-diagnosis display?

- YES >> Proceed to diagnosis procedure. Refer to [BRC-34, "Diagnosis Procedure"](#).  
NO >> INSPECTION END

### Diagnosis Procedure

INFOID:000000001600891

### INSPECTION PROCEDURE

#### 1. CHECK CONNECTOR

1. Turn ignition switch OFF.
2. Disconnect ABS actuator and electric unit (control unit) connector.
3. Check terminal for deformation, disconnection, looseness, and so on. If any malfunction is found, repair or replace terminal.
4. Reconnect connectors and then perform the self-diagnosis. Refer to [BRC-16, "CONSULT-III Function \(ABS\)"](#).

Is any item indicated on the self-diagnosis display?

- YES >> GO TO 2  
NO >> Poor connection of connector terminal. Repair or replace connector.

#### 2. CHECK SOLENOID AND ACTUATOR RELAY POWER SUPPLY CIRCUIT

# C1120, C1122, C1190 IN ABS SOL

[ABS]

## < COMPONENT DIAGNOSIS >

1. Turn ignition switch OFF.
2. Disconnect ABS actuator and electric unit (control unit) connector.
3. Check voltage between ABS actuator and electric unit (control unit) harness connector terminal and ground.

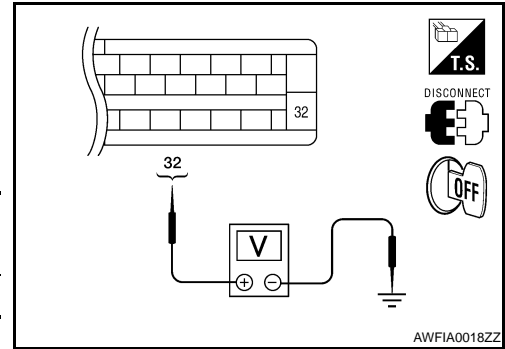

ABS actuator and electric unit (control unit)		—	Voltage
Connector	Terminal		
E125	32	Ground	Battery voltage

Is the inspection result normal?

- YES >> GO TO 3  
 NO >> Repair or replace malfunctioning components.

### 3.CHECK SOLENOID AND ACUATOR RELAY GROUND CIRCUIT

Check continuity between ABS actuator and electric unit (control unit) harness connector terminals and ground.

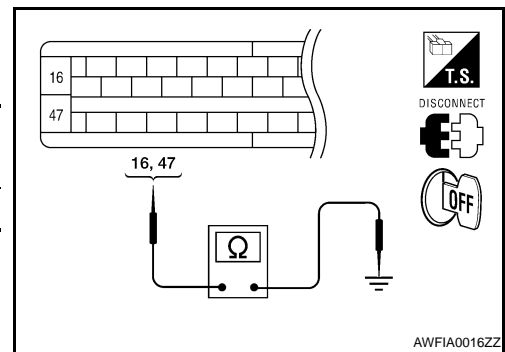

ABS actuator and electric unit (control unit)		—	Continuity
Connector	Terminal		
E125	16, 47	Ground	Yes

Is the inspection result normal?

- YES >> Replace ABS actuator and electric unit (control unit).  
 Refer to [BRC-64, "Removal and Installation"](#).  
 NO >> Repair or replace malfunctioning components.

## Component Inspection

INFOID:000000001600892

### 1.CHECK ACTIVE TEST

1. Select each test menu item on "ACTIVE TEST".
2. On the display, touch "UP", "KEEP", and "DOWN", and check that the system operates as shown in the table below.

Operation		ABS solenoid valve			ABS solenoid valve (ACT)		
		UP	KEEP	DOWN	UP	ACTUA-TOR UP	ACTUA-TOR KEEP
FR RH SOL FR RH ABS SOLE- NOID (ACT)	FR RH IN SOL	OFF	ON	ON	OFF	OFF	OFF
	FR RH OUT SOL	OFF	OFF	ON*	OFF	OFF	OFF
FR LH SOL FR LH ABS SOLE- NOID (ACT)	FR LH IN SOL	OFF	ON	ON	OFF	OFF	OFF
	FR LH OUT SOL	OFF	OFF	ON*	OFF	OFF	OFF
REAR SOL	RR RH IN SOL	OFF	ON	ON	OFF	OFF	OFF
	RR RH OUT SOL	OFF	OFF	ON*	OFF	OFF	OFF
	RR LH IN SOL	OFF	ON	ON	OFF	OFF	OFF
	RR LH OUT SOL	OFF	OFF	ON*	OFF	OFF	OFF

\*: ON for 1 to 2 seconds after the touch, and then OFF

Is the inspection result normal?

- YES >> INSPECTION END  
 NO >> Go to diagnosis procedure. Refer to [BRC-34, "Diagnosis Procedure"](#).

# C1121, C1123, C1191 OUT ABS SOL

< COMPONENT DIAGNOSIS >

[ABS]

## C1121, C1123, C1191 OUT ABS SOL

### Description

INFOID:000000001600894

The solenoid valve increases, holds or decreases the fluid pressure of each brake caliper according to the signals transmitted by the ABS actuator and electric unit (control unit).

### DTC Logic

INFOID:000000001600895

### DTC DETECTION LOGIC

DTC	Display item	Malfunction detected condition	Possible cause
C1121	FR LH OUT ABS SOL	When the control unit detects a malfunction in the front LH outlet solenoid circuit.	• ABS actuator and electric unit (control unit)
C1123	FR RH OUT ABS SOL	When the control unit detects a malfunction in the front RH outlet solenoid circuit.	
C1191	R-AV	When the control unit detects a malfunction in the rear outlet solenoid circuit.	

### DTC CONFIRMATION PROCEDURE

#### 1. CHECK SELF-DIAGNOSIS RESULTS

Check the self-diagnosis results.

Self-diagnosis results
FR LH OUT ABS SOL
FR RH OUT ABS SOL
R-AV

Is above displayed on the self-diagnosis display?

- YES >> Proceed to diagnosis procedure. Refer to [BRC-36, "Diagnosis Procedure"](#).  
NO >> INSPECTION END

### Diagnosis Procedure

INFOID:000000001674220

### INSPECTION PROCEDURE

#### 1. CHECK CONNECTOR

1. Turn ignition switch OFF.
2. Disconnect ABS actuator and electric unit (control unit) connector.
3. Check terminal for deformation, disconnection, looseness, and so on. If any malfunction is found, repair or replace terminal.
4. Reconnect connectors and then perform the self-diagnosis. Refer to [BRC-16, "CONSULT-III Function \(ABS\)"](#).

Is any item indicated on the self-diagnosis display?

- YES >> GO TO 2  
NO >> Poor connection of connector terminal. Repair or replace connector.

#### 2. CHECK SOLENOID AND ACTUATOR RELAY POWER SUPPLY CIRCUIT

# C1121, C1123, C1191 OUT ABS SOL

[ABS]

## < COMPONENT DIAGNOSIS >

1. Turn ignition switch OFF.
2. Disconnect ABS actuator and electric unit (control unit) connector.
3. Check voltage between ABS actuator and electric unit (control unit) harness connector terminal and ground.

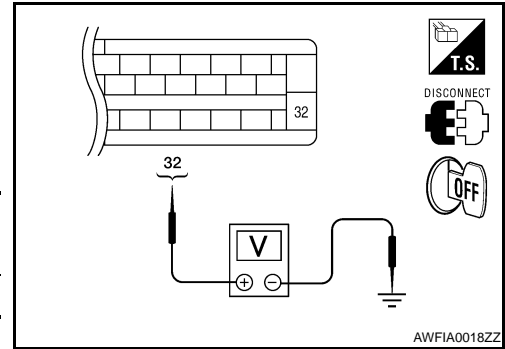

ABS actuator and electric unit (control unit)		—	Voltage
Connector	Terminal		
E125	32	Ground	Battery voltage

Is the inspection result normal?

- YES >> GO TO 3  
 NO >> Repair or replace malfunctioning components.

### 3.CHECK SOLENOID AND ACUATOR RELAY GROUND CIRCUIT

Check continuity between ABS actuator and electric unit (control unit) harness connector terminals and ground.

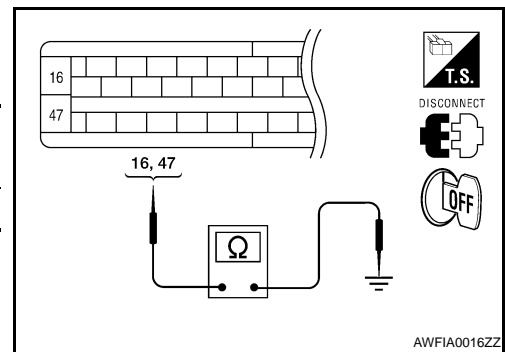

ABS actuator and electric unit (control unit)		—	Continuity
Connector	Terminal		
E125	16, 47	Ground	Yes

Is the inspection result normal?

- YES >> Replace ABS actuator and electric unit (control unit).  
 Refer to [BRC-64, "Removal and Installation"](#).  
 NO >> Repair or replace malfunctioning components.

## Component Inspection

INFOID:000000001674221

### 1.CHECK ACTIVE TEST

1. Select each test menu item on "ACTIVE TEST".
2. On the display, touch "UP", "KEEP", and "DOWN", and check that the system operates as shown in the table below.

Operation		ABS solenoid valve			ABS solenoid valve (ACT)		
		UP	KEEP	DOWN	UP	ACTUA-TOR UP	ACTUA-TOR KEEP
FR RH SOL FR RH ABS SOLE- NOID (ACT)	FR RH IN SOL	OFF	ON	ON	OFF	OFF	OFF
	FR RH OUT SOL	OFF	OFF	ON*	OFF	OFF	OFF
FR LH SOL FR LH ABS SOLE- NOID (ACT)	FR LH IN SOL	OFF	ON	ON	OFF	OFF	OFF
	FR LH OUT SOL	OFF	OFF	ON*	OFF	OFF	OFF
REAR SOL	RR RH IN SOL	OFF	ON	ON	OFF	OFF	OFF
	RR RH OUT SOL	OFF	OFF	ON*	OFF	OFF	OFF
	RR LH IN SOL	OFF	ON	ON	OFF	OFF	OFF
	RR LH OUT SOL	OFF	OFF	ON*	OFF	OFF	OFF

\*: ON for 1 to 2 seconds after the touch, and then OFF

Is the inspection result normal?

- YES >> INSPECTION END  
 NO >> Go to diagnosis procedure. Refer to [BRC-36, "Diagnosis Procedure"](#).

# C1140 ACTUATOR RLY

[ABS]

< COMPONENT DIAGNOSIS >

## C1140 ACTUATOR RLY

### Description

INFOID:000000001600903

Activates or deactivates each solenoid valve according to the signals transmitted by the ABS actuator and electric unit (control unit).

### DTC Logic

INFOID:000000001600904

### DTC DETECTION LOGIC

DTC	Display item	Malfunction detected condition	Possible cause
C1140	ACTUATOR RLY	ABS actuator relay or circuit malfunction.	<ul style="list-style-type: none"> <li>Harness or connector</li> <li>ABS actuator and electric unit (control unit)</li> </ul>

### DTC CONFIRMATION PROCEDURE

#### 1.CHECK SELF-DIAGNOSIS RESULTS

Check the self-diagnosis results.

Self-diagnosis results
ACTUATOR RLY

Is above displayed on the self-diagnosis display?

- YES >> Proceed to diagnosis procedure. Refer to [BRC-38. "Diagnosis Procedure"](#).  
 NO >> INSPECTION END

### Diagnosis Procedure

INFOID:000000001674222

### INSPECTION PROCEDURE

#### 1.CHECK CONNECTOR

- Turn ignition switch OFF.
- Disconnect ABS actuator and electric unit (control unit) connector.
- Check terminal for deformation, disconnection, looseness, and so on. If any malfunction is found, repair or replace terminal.
- Reconnect connectors and then perform the self-diagnosis. Refer to [BRC-16. "CONSULT-III Function \(ABS\)"](#).

Is any item indicated on the self-diagnosis display?

- YES >> GO TO 2  
 NO >> Poor connection of connector terminal. Repair or replace connector.

#### 2.CHECK SOLENOID AND ACTUATOR RELAY POWER SUPPLY CIRCUIT

- Turn ignition switch OFF.
- Disconnect ABS actuator and electric unit (control unit) connector.
- Check voltage between ABS actuator and electric unit (control unit) harness connector terminal and ground.

ABS actuator and electric unit (control unit)		—	Voltage
Connector	Terminal		
E125	32	Ground	Battery voltage

Is the inspection result normal?

- YES >> GO TO 3  
 NO >> Repair or replace malfunctioning components.

#### 3.CHECK SOLENOID AND ACUATOR RELAY GROUND CIRCUIT

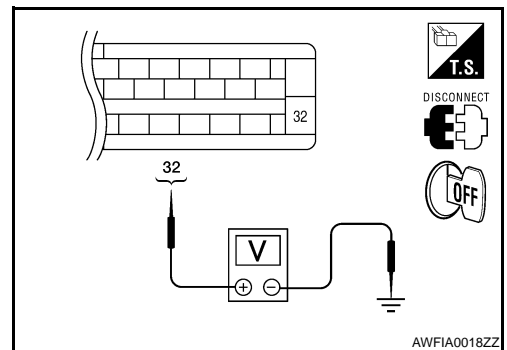

# C1140 ACTUATOR RLY

[ABS]

## < COMPONENT DIAGNOSIS >

Check continuity between ABS actuator and electric unit (control unit) harness connector terminals and ground.

ABS actuator and electric unit (control unit)		—	Continuity
Connector	Terminal		
E125	16, 47	Ground	Yes

Is the inspection result normal?

- YES >> Replace ABS actuator and electric unit (control unit).  
Refer to [BRC-64, "Removal and Installation"](#).
- NO >> Repair or replace malfunctioning components.

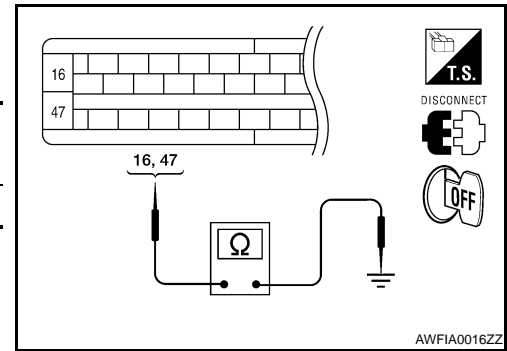

## Component Inspection

INFOID:000000001600906

### 1. CHECK ACTIVE TEST

- On "ACTIVE TEST", select "ABS MOTOR".
- Touch ON and OFF on screen. Make sure motor relay and actuator relay operates as shown in table below.

Operation	ON	OFF
MOTOR RELAY	ON	OFF
ACTUATOR RLY	ON	ON

Is the inspection result normal?

- YES >> INSPECTION END
- NO >> Go to diagnosis procedure. Refer to [BRC-38, "Diagnosis Procedure"](#).

A  
B  
C  
D  
E  
G  
H  
I  
J  
K  
L  
M  
N  
O  
P

BRC

# U1000 CAN COMM CIRCUIT

< COMPONENT DIAGNOSIS >

[ABS]

## U1000 CAN COMM CIRCUIT

### Description

INFOID:000000001600947

CAN (Controller Area Network) is a serial communication line for real time application. It is an on-vehicle multiplex communication line with high data communication speed and excellent error detection ability. Many electronic control units are equipped onto a vehicle, and each control unit shares information and links with other control units during operation (not independent). In CAN communication, control units are connected with 2 communication lines (CAN H line, CAN L line) allowing a high rate of information transmission with less wiring. Each control unit transmits/receives data but selectively reads required data only.

### DTC Logic

INFOID:000000001600948

### DTC DETECTION LOGIC

DTC	Display item	Malfunction detected condition	Possible cause
U1000	CAN COMM CIRCUIT	When ABS actuator and electric unit (control unit) is not transmitting or receiving CAN communication signal for 2 seconds or more.	<ul style="list-style-type: none"><li>• CAN communication line</li><li>• ABS actuator and electric unit (control unit)</li></ul>

### Diagnosis Procedure

INFOID:000000001600949

#### INSPECTION PROCEDURE

#### 1. CHECK CONNECTOR

1. Turn ignition switch OFF, disconnect the ABS actuator and electric unit (control unit) connector, and check the terminals for deformation, disconnection, looseness, and so on. If there is a malfunction, repair or replace the terminal.
2. Reconnect connector and perform self-diagnosis.

Is "CAN COMM CIRCUIT" displayed in self-diagnosis display items?

- YES >> Print out the self-diagnostic results, and refer to [LAN-14, "Trouble Diagnosis Flow Chart"](#).
- NO >> Connector terminal is loose, damaged, open, or shorted.



# ABS WARNING LAMP

[ABS]

< COMPONENT DIAGNOSIS >

## ABS WARNING LAMP

### Description

INFOID:000000001600955

x: ON –: OFF

Condition	ABS warning lamp
Ignition switch OFF	–
For 1 second after turning ON ignition switch	x
1 second later after turning ON ignition switch	–
ABS function is malfunctioning.	x
EBD function is malfunctioning.	x

### Component Function Check

INFOID:000000001600956

#### 1.CHECK ABS WARNING LAMP OPERATION

Check that the lamp illuminates for approximately 1 second after the ignition switch is turned ON.

Is the inspection result normal?

YES >> INSPECTION END

NO >> Go to diagnosis procedure. Refer to [BRC-41, "Diagnosis Procedure"](#).

#### Diagnosis Procedure

INFOID:000000001600957

#### 1.CHECK SELF-DIAGNOSIS

Perform ABS actuator and electric unit (control unit) self-diagnosis. Refer to [BRC-16, "CONSULT-III Function \(ABS\)"](#).

Is the inspection result normal?

YES >> GO TO 2

NO >> Check items displayed by self-diagnosis.

#### 2.CHECK COMBINATION METER

Check if the indication and operation of combination meter are normal. Refer to [MWI-26, "Diagnosis Description"](#).

Is the inspection result normal?

YES >> Replace ABS actuator and electric unit (control unit). Refer to [BRC-64, "Removal and Installation"](#).

NO >> Replace combination meter. Refer to [MWI-72, "Removal and Installation"](#).

# BRAKE WARNING LAMP

[ABS]

< COMPONENT DIAGNOSIS >

## BRAKE WARNING LAMP

### Description

INFOID:000000001600958

×: ON –: OFF

Condition	Brake warning lamp (Note 1)
Ignition switch OFF	–
For 1 second after turning ON ignition switch	× (Note 2)
1 second later after turning ON ignition switch	× (Note 2)
EBD function is malfunctioning.	×

#### NOTE:

- 1: Brake warning lamp will turn on in case of parking brake operation (when switch is ON) or of brake fluid level switch operation (when brake fluid is insufficient).
- 2: After starting engine, brake warning lamp is turned off.

### Component Function Check

INFOID:000000001600959

#### 1. BRAKE WARNING LAMP OPERATION CHECK

Check that the lamp illuminates for approximately 1 second after the ignition switch is turned ON.

Is the inspection result normal?

YES >> INSPECTION END

NO >> Go to diagnosis procedure. Refer to [BRC-42, "Diagnosis Procedure"](#).

### Diagnosis Procedure

INFOID:000000001600960

#### 1. CHECK SELF-DIAGNOSIS

Perform ABS actuator and electric unit (control unit) self-diagnosis. Refer to [BRC-16, "CONSULT-III Function \(ABS\)"](#).

Is the inspection result normal?

YES >> GO TO 2

NO >> Check items displayed by self-diagnosis.

#### 2. CHECK COMBINATION METER

Check if the indication and operation of combination meter are normal. Refer to [MWI-26, "Diagnosis Description"](#).

Is the inspection result normal?

YES >> Replace ABS actuator and electric unit (control unit). Refer to [BRC-64, "Removal and Installation"](#).

NO >> Replace combination meter. Refer to [MWI-72, "Removal and Installation"](#).

# ABS ACTUATOR AND ELECTRIC UNIT (CONTROL UNIT)

< ECU DIAGNOSIS >

[ABS]

## ECU DIAGNOSIS

### ABS ACTUATOR AND ELECTRIC UNIT (CONTROL UNIT)

Reference Value

INFOID:000000001600967

VALUES ON THE DIAGNOSIS TOOL

#### CAUTION:

The display shows the control unit calculation data, so a normal value might be displayed even in the event the output circuit (harness) is open or short-circuited.

CONSULT-III MONITOR ITEM

Monitor item	Display content	Data monitor	
		Condition	Reference value in normal operation
FR LH SENSOR	Wheel speed	0 [km/h (MPH)]	Vehicle stopped
		Nearly matches the speed meter display (± 10% or less)	Vehicle running (Note 1)
FR RH SENSOR	Wheel speed	0 [km/h (MPH)]	Vehicle stopped
		Nearly matches the speed meter display (± 10% or less)	Vehicle running (Note 1)
RR LH SENSOR	Wheel speed	0 [km/h (MPH)]	Vehicle stopped
		Nearly matches the speed meter display (± 10% or less)	Vehicle running (Note 1)
RR RH SENSOR	Wheel speed	0 [km/h (MPH)]	Vehicle stopped
		Nearly matches the speed meter display (± 10% or less)	Vehicle running (Note 1)
STOP LAMP SW	Stop lamp switch signal status	When brake pedal is depressed	ON
		When brake pedal is released	OFF
BATTERY VOLT	Battery voltage supplied to the ABS actuator and electric unit (control unit)	Ignition switch ON	10 – 16 V
FR RH IN SOL	Operation status of each solenoid valve	Actuator (solenoid valve) is active ("ACTIVE TEST" with CONSULT-III) or actuator relay is inactive (in fail-safe mode)	ON
		When the actuator (solenoid valve) is not active and actuator relay is active (ignition switch ON)	OFF
FR RH OUT SOL	Operation status of each solenoid valve	Actuator (solenoid valve) is active ("ACTIVE TEST" with CONSULT-III) or actuator relay is inactive (in fail-safe mode)	ON
		When the actuator (solenoid valve) is not active and actuator relay is active (ignition switch ON)	OFF
FR LH IN SOL	Operation status of each solenoid valve	Actuator (solenoid valve) is active ("ACTIVE TEST" with CONSULT-III) or actuator relay is inactive (in fail-safe mode)	ON
		When the actuator (solenoid valve) is not active and actuator relay is active (ignition switch ON)	OFF
FR LH OUT SOL	Operation status of each solenoid valve	Actuator (solenoid valve) is active ("ACTIVE TEST" with CONSULT-III) or actuator relay is inactive (in fail-safe mode)	ON
		When the actuator (solenoid valve) is not active and actuator relay is active (ignition switch ON)	OFF

# ABS ACTUATOR AND ELECTRIC UNIT (CONTROL UNIT)

< ECU DIAGNOSIS >

[ABS]

Monitor item	Display content	Data monitor	
		Condition	Reference value in normal operation
REAR IN SOL	Operation status of each solenoid valve	Actuator (solenoid valve) is active ("ACTIVE TEST" with CONSULT-III) or actuator relay is inactive (in fail-safe mode)	ON
		When the actuator (solenoid valve) is not active and actuator relay is active (ignition switch ON)	OFF
REAR OUT SOL	Operation status of each solenoid valve	Actuator (solenoid valve) is active ("ACTIVE TEST" with CONSULT-III) or actuator relay is inactive (in fail-safe mode)	ON
		When the actuator (solenoid valve) is not active and actuator relay is active (ignition switch ON)	OFF
MOTOR RELAY	Motor and motor relay operation	When the motor relay and motor are operating	ON
		When the motor relay and motor are not operating	OFF
ACTUATOR RLY	Actuator relay operation	When the actuator relay is operating	ON
		When the actuator relay is not operating	OFF
ABS WARN LAMP	ABS warning lamp (Note 2)	When ABS warning lamp is ON	ON
		When ABS warning lamp is OFF	OFF
EBD SIGNAL	EBD operation	EBD is active	ON
		EBD is inactive	OFF
ABS SIGNAL	ABS operation	ABS is active	ON
		ABS is inactive	OFF
EBD FAIL SIG	EBD fail-safe signal	In EBD fail-safe	ON
		EBD is normal	OFF
ABS FAIL SIG	ABS fail-safe signal	In ABS fail-safe	ON
		ABS is normal	OFF

**NOTE:**

- 1: Confirm tire pressure is normal.
- 2: On and off timing for warning lamp and indicator lamp. Refer to [BRC-41. "Description"](#).

**TERMINAL LAYOUT**

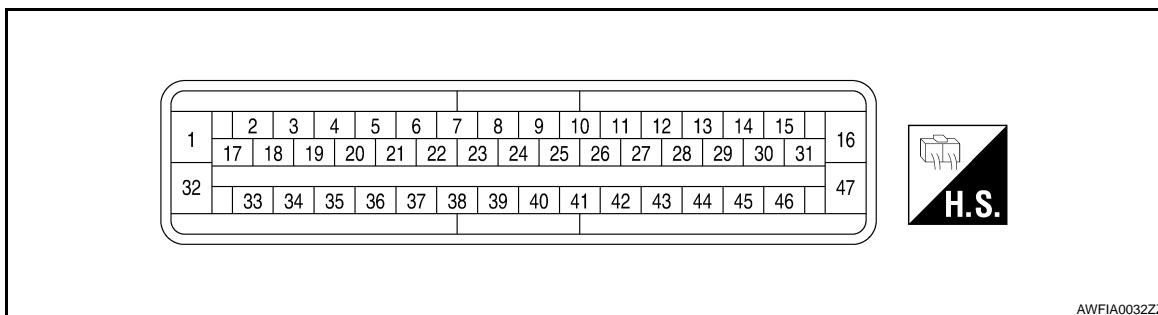

# ABS ACTUATOR AND ELECTRIC UNIT (CONTROL UNIT)

< ECU DIAGNOSIS >

[ABS]

## Wiring Diagram

INFOID:000000001600968

--- : DATA LINE

### BRAKE CONTROL SYSTEM - ABS

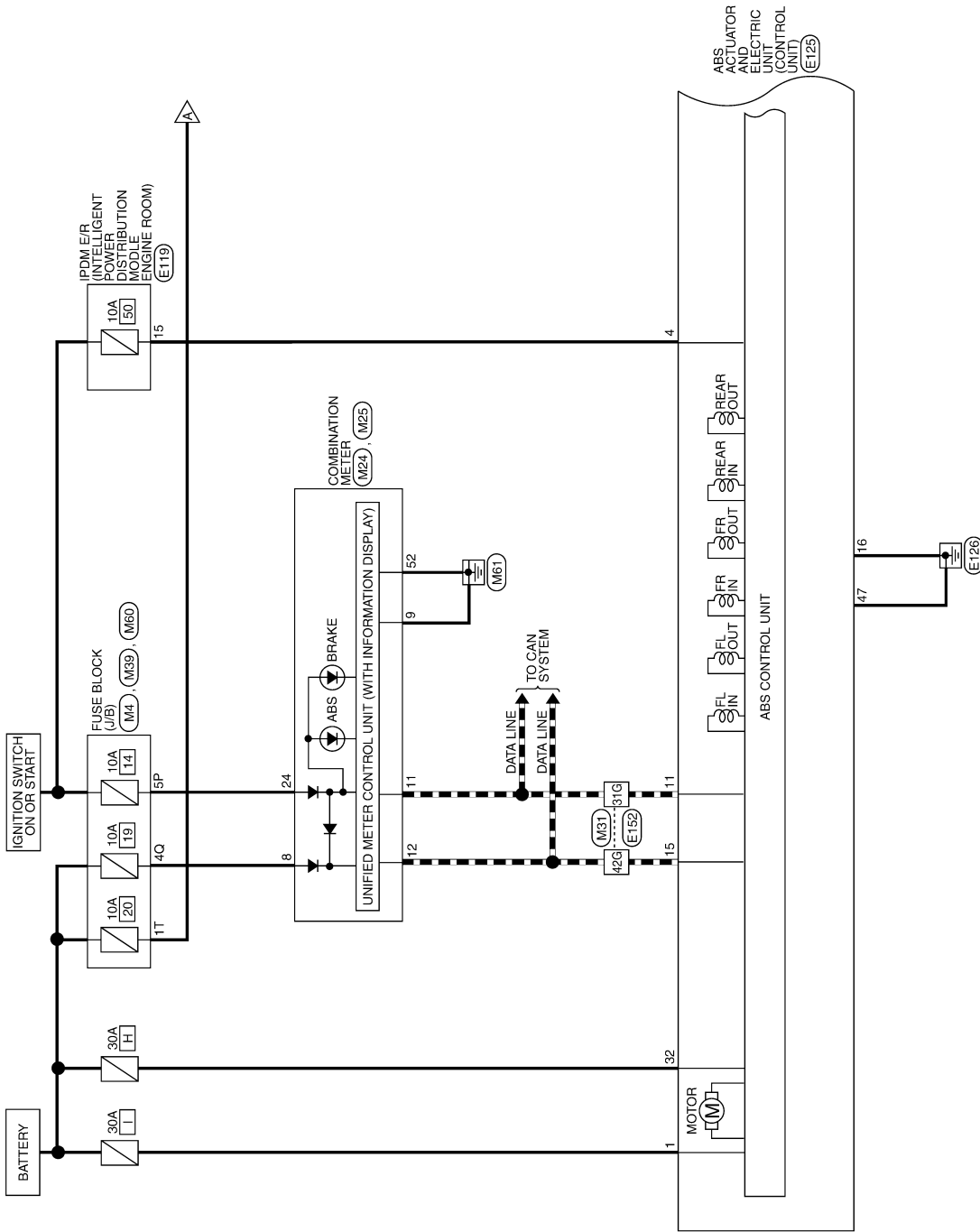

A  
B  
C  
D  
E  
BRC  
G  
H  
I  
J  
K  
L  
M  
N  
O  
P

AWFWA0001GI

# ABS ACTUATOR AND ELECTRIC UNIT (CONTROL UNIT)

< ECU DIAGNOSIS >

[ABS]

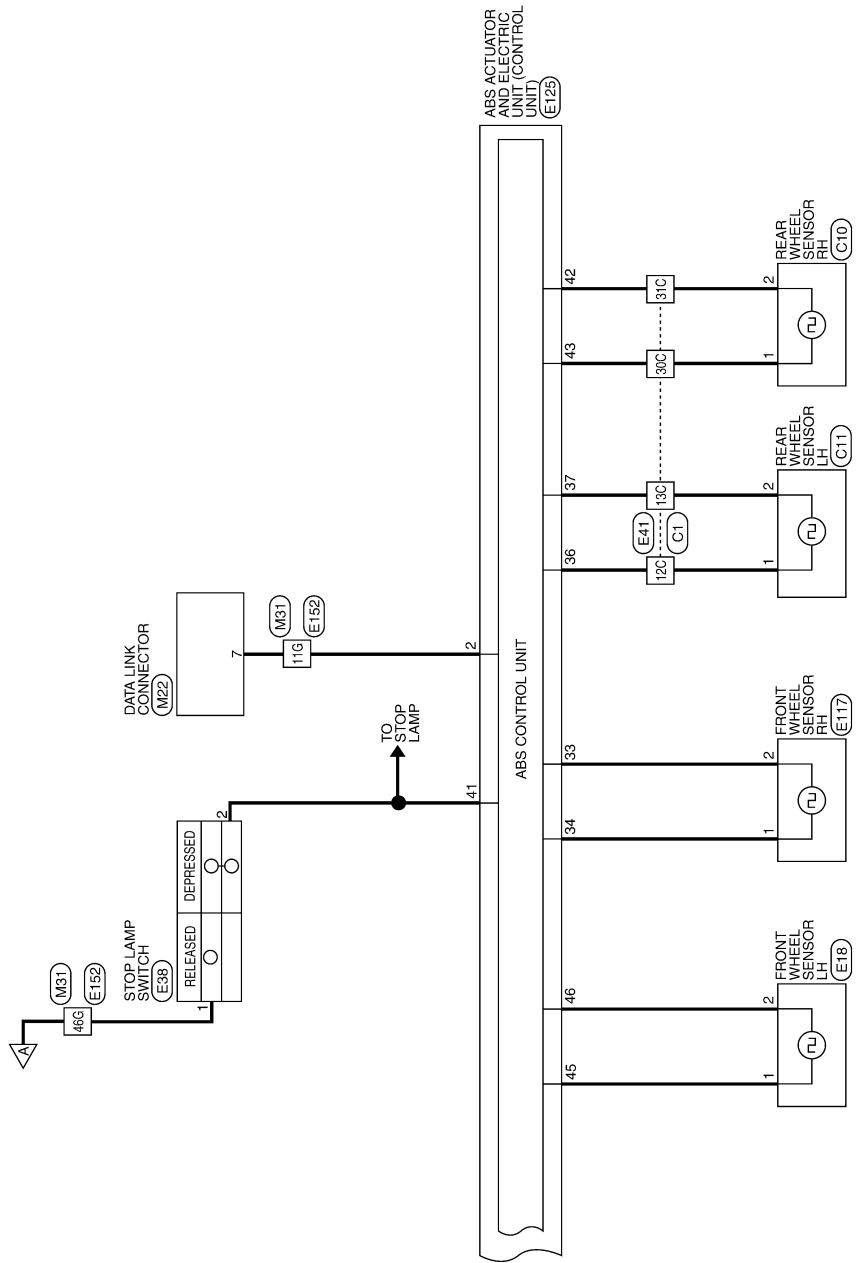

AWFWA0002GI

# ABS ACTUATOR AND ELECTRIC UNIT (CONTROL UNIT)

< ECU DIAGNOSIS >

[ABS]

## BRAKE CONTROL SYSTEM - ABS CONNECTORS

Connector No.	M4
Connector Name	FUSE BLOCK (J/B)
Connector Color	WHITE

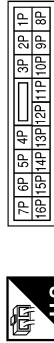

Terminal No.	Color of Wire	Signal Name
5P	O/L	-

Connector No.	M22
Connector Name	DATA LINK CONNECTOR
Connector Color	WHITE

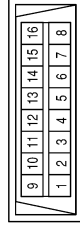

Terminal No.	Color of Wire	Signal Name
7	G/W	K-LINE

Connector No.	M24
Connector Name	COMBINATION METER
Connector Color	WHITE

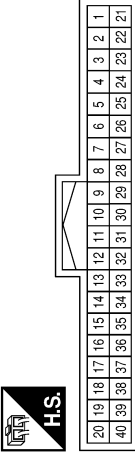

Terminal No.	Color of Wire	Signal Name
8	Y/R	-
9	B	-
11	L	CAN+H
12	P	CAN-L
24	O/L	-

Connector No.	M25
Connector Name	COMBINATION METER
Connector Color	WHITE

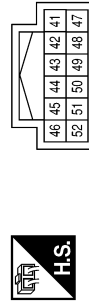

Terminal No.	Color of Wire	Signal Name
52	B	-

Connector No.	M31
Connector Name	WIRE TO WIRE
Connector Color	WHITE

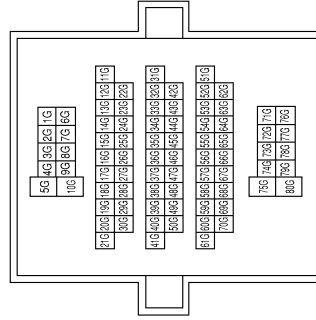

Terminal No.	Color of Wire	Signal Name
11G	G/W	-
31G	L	-
42G	P	-
46G	R/Y	-

AWFIA0049GB

A  
B  
C  
D  
E  
G  
H  
I  
J  
K  
L  
M  
N  
O  
P

BRC

# ABS ACTUATOR AND ELECTRIC UNIT (CONTROL UNIT)

< ECU DIAGNOSIS >

[ABS]

Connector No.	E18
Connector Name	FRONT WHEEL SENSOR LH
Connector Color	GRAY



Terminal No.	Color of Wire	Signal Name
1	G/O	-
2	BR/W	-

Connector No.	M60
Connector Name	FUSE BLOCK (J/B)
Connector Color	WHITE

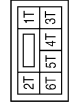

Terminal No.	Color of Wire	Signal Name
1T	R/Y	-

Connector No.	M39
Connector Name	FUSE BLOCK (J/B)
Connector Color	WHITE

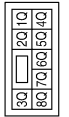

Terminal No.	Color of Wire	Signal Name
4Q	Y/R	-

Connector No.	E41
Connector Name	WIRE TO WIRE
Connector Color	GRAY

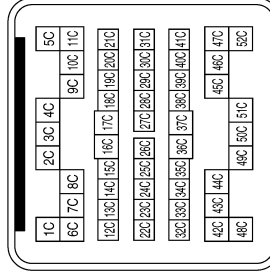

Terminal No.	Color of Wire	Signal Name
12C	L	-
13C	P	-
30C	G/Y	-
31C	V	-

Connector No.	E38
Connector Name	STOP LAMP SWITCH (COLUMN SHIFT)
Connector Color	WHITE



Terminal No.	Color of Wire	Signal Name
1	R/Y	-
2	R/B	-

Connector No.	E38
Connector Name	STOP LAMP SWITCH (FLOOR SHIFT)
Connector Color	BLACK



Terminal No.	Color of Wire	Signal Name
1	R/Y	-
2	R/B	-

AWFIA0050GB



# ABS ACTUATOR AND ELECTRIC UNIT (CONTROL UNIT)

< ECU DIAGNOSIS >

[ABS]

Connector No.	E117
Connector Name	FRONT WHEEL SENSOR RH
Connector Color	GRAY



Terminal No.	Color of Wire	Signal Name
1	B/R	-
2	BR	-

Connector No.	E119
Connector Name	IPDM E/R (INTELLIGENT POWER DISTRIBUTION MODULE ENGINE ROOM)
Connector Color	WHITE

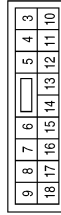

Terminal No.	Color of Wire	Signal Name
15	GR	ABS IGN SUPPLY

Connector No.	E125
Connector Name	ABS ACTUATOR AND ELECTRIC UNIT (CONTROL UNIT)
Connector Color	BLACK

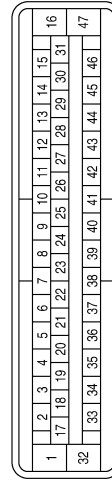

Terminal No.	Color of Wire	Signal Name
1	B/Y	MOTOR_SUPPLY
2	P	DIAG_K
4	GR	IGN
11	L	CAN-H
15	P	CAN-L
16	B	GND
32	Y	VALVE_ECU_SUPPLY
33	BR	DS_FR
34	B/R	DP_FR

Terminal No.	Color of Wire	Signal Name
36	L	DP-RL
37	P	DS_RL
41	R/G	STOP_LAMP_SWITCH
42	V	DS_RR
43	G/Y	DP_RR
45	G/O	DP_FL
46	BR/W	DS_FL
47	B	MOTOR_GND

AWFIA0051GB

A  
B  
C  
D  
E  
BRC  
G  
H  
I  
J  
K  
L  
M  
N  
O  
P

# ABS ACTUATOR AND ELECTRIC UNIT (CONTROL UNIT)

< ECU DIAGNOSIS >

[ABS]

Connector No.	C1
Connector Name	WIRE TO WIRE
Connector Color	GRAY

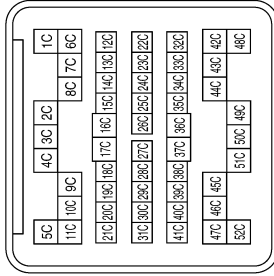

Terminal No.	Color of Wire	Signal Name
12C	L	-
13C	P	-
30C	G/Y	-
31C	V	-

Terminal No.	Color of Wire	Signal Name
11G	G/W	-
31G	L	-
42G	P	-
46G	R/Y	-

Connector No.	E152
Connector Name	WIRE TO WIRE
Connector Color	WHITE

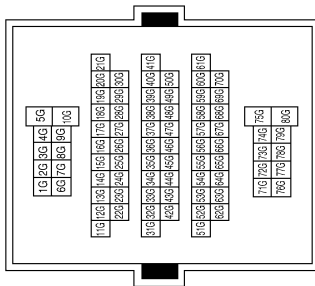

Connector No.	C11
Connector Name	REAR WHEEL SENSOR LH
Connector Color	BROWN



Terminal No.	Color of Wire	Signal Name
1	L	-
2	P	-

Connector No.	C10
Connector Name	REAR WHEEL SENSOR RH
Connector Color	GRAY



Terminal No.	Color of Wire	Signal Name
1	G/Y	-
2	V	-

AWFIA0052GB

## Fail-Safe

### CAUTION:

If the Fail-Safe function is activated, perform Self Diagnosis for ABS system.

### ABS/EBD SYSTEM

In case of an electrical malfunction with the ABS, the ABS warning lamp will turn on. In case of an electrical malfunction with the EBD system, the BRAKE warning lamp and ABS warning lamp will turn on.

# ABS ACTUATOR AND ELECTRIC UNIT (CONTROL UNIT)

[ABS]

## < ECU DIAGNOSIS >

The system will revert to one of the following conditions of the Fail-Safe function.

1. For ABS malfunction, only the EBD is operative and the condition of the vehicle is the same condition of vehicles without ABS system.
2. For EBD malfunction, the EBD and ABS become inoperative, and the condition of the vehicle is the same as the condition of vehicles without ABS or EBD system.

## DTC No. Index

INFOID:000000001600970

DTC	Items (CONSULT screen terms)	Reference
C1101	RR RH SENSOR-1	<a href="#">BRC-19, "Description"</a>
C1102	RR LH SENSOR-1	
C1103	FR RH SENSOR-1	
C1104	FR LH SENSOR-1	
C1105	RR RH SENSOR-2	<a href="#">BRC-22, "Description"</a>
C1106	RR LH SENSOR-2	
C1107	FR RH SENSOR-2	
C1108	FR LH SENSOR-2	
C1109	BATTERY VOLTAGE [ABNORMAL]	<a href="#">BRC-25, "Description"</a>
C1110	CONTROLLER FAILURE	<a href="#">BRC-27, "DTC Logic"</a>
C1111	PUMP MOTOR	<a href="#">BRC-28, "Description"</a>
C1113	G-SENSOR	<a href="#">BRC-27, "DTC Logic"</a>
C1115	ABS SENSOR [ABNORMAL SIGNAL]	<a href="#">BRC-30, "Description"</a>
C1116	STOP LAMP SW	<a href="#">BRC-33, "Description"</a>
C1120	FR LH IN ABS SOL	<a href="#">BRC-34, "Description"</a>
C1121	FR LH OUT ABS SOL	<a href="#">BRC-36, "Description"</a>
C1122	FR RH IN ABS SOL	<a href="#">BRC-34, "Description"</a>
C1123	FR RH OUT ABS SOL	<a href="#">BRC-36, "Description"</a>
C1140	ACTUATOR RLY	<a href="#">BRC-38, "Description"</a>
C1190	REAR IN ABS SOL	<a href="#">BRC-34, "Description"</a>
C1191	REAR OUT ABS SOL	<a href="#">BRC-36, "Description"</a>
U1000	CAN COMM CIRCUIT	<a href="#">BRC-40, "Description"</a>

A  
B  
C  
D  
E  
BRC  
G  
H  
I  
J  
K  
L  
M  
N  
O  
P

&lt; SYMPTOM DIAGNOSIS &gt;

# SYMPTOM DIAGNOSIS

## ABS

### Symptom Table

INFOID:000000001600971

If ABS warning lamp turns ON, perform self-diagnosis.

Symptom	Check item	Reference
Excessive ABS function operation frequency	Brake force distribution	<a href="#">BRC-53. "Diagnosis Procedure"</a>
	Looseness of front and rear axle	
	Wheel sensor and rotor system	
Unexpected pedal reaction	Brake pedal stroke	<a href="#">BRC-54. "Diagnosis Procedure"</a>
	Make sure the braking force is sufficient when the ABS is not operating.	
The braking distance is long	Check stopping distance when the ABS is not operating.	<a href="#">BRC-55. "Diagnosis Procedure"</a>
ABS function does not operate (Note 1)	ABS actuator and electric unit (control unit)	<a href="#">BRC-56. "Diagnosis Procedure"</a>
Pedal vibration or ABS operation sound occurs (Note 2)	Brake pedal	<a href="#">BRC-57. "Diagnosis Procedure"</a>
	ABS actuator and electric unit (control unit)	

**NOTE:**

- 1: The ABS does not operate when the speed is 10 km/h (6 MPH) or less.
- 2: Under the following conditions, ABS is activated and vibration is felt when brake pedal is lightly depressed. However, this is normal.
  - When shifting gears
  - When driving on slippery road
  - During cornering at high speed
  - When passing over bumps or grooves [at approximately 50 mm (1.97 in) or more]
  - When pulling away just after starting engine [at approximately 10 km/h (6 MPH) or higher]

# EXCESSIVE ABS FUNCTION OPERATION FREQUENCY

[ABS]

< SYMPTOM DIAGNOSIS >

## EXCESSIVE ABS FUNCTION OPERATION FREQUENCY

### Diagnosis Procedure

INFOID:000000001600972

#### 1.CHECK START

Check front and rear brake force distribution using a brake tester.

Is the inspection result normal?

YES >> GO TO 2

NO >> Check brake system.

#### 2.CHECK FRONT AND REAR AXLE

Make sure that there is no excessive play in the front and rear axles. Refer to front: [FAX-5. "On-Vehicle Inspection and Service"](#), Rear: [RAX-5. "On-Vehicle Inspection"](#).

Is the inspection result normal?

YES >> GO TO 3

NO >> Repair or replace malfunctioning components.

#### 3.CHECK WHEEL SENSOR AND SENSOR ROTOR

Check the following.

- Wheel sensor installation for damage.
- Sensor rotor installation for damage.
- Wheel sensor connector connection.
- Wheel sensor harness inspection.

Is the inspection result normal?

YES >> GO TO 4

NO >> • Replace wheel sensor or sensor rotor. Refer to [BRC-62. "Removal and Installation"](#).  
• Repair harness.

#### 4.CHECK ABS WARNING LAMP DISPLAY

Make sure that the ABS warning lamp is turned off after the ignition switch is turned ON or when driving.

Is the ABS warning lamp illuminated?

YES >> Perform self-diagnosis. Refer to [BRC-16. "CONSULT-III Function \(ABS\)"](#).

NO >> Normal

A  
B  
C  
D  
E  
BRC  
G  
H  
I  
J  
K  
L  
M  
N  
O  
P

# UNEXPECTED PEDAL REACTION

[ABS]

< SYMPTOM DIAGNOSIS >

## UNEXPECTED PEDAL REACTION

### Diagnosis Procedure

INFOID:000000001600973

#### 1.CHECK BRAKE PEDAL STROKE

Check brake pedal stroke. Refer to [BR-14, "Inspection and Adjustment"](#).

Is the stroke too large?

- YES >> • Bleed air from brake tube and hose. Refer to [BR-16, "Bleeding Brake System"](#).  
• Check brake pedal, brake booster, and master cylinder for mount play, looseness, brake system fluid leakage, etc. Refer to [BR-14, "Inspection and Adjustment"](#) (brake pedal), [BR-11, "On Board Inspection"](#) (master cylinder), [BR-10, "Inspection"](#) (brake booster).

NO >> GO TO 2

#### 2.CHECK FUNCTION

Disconnect ABS actuator and electric unit (control unit) connector to deactivate ABS. Check if braking force is normal in this condition. Connect connector after inspection.

Is the inspection result normal?

- YES >> Normal  
NO >> Check brake system.

# THE BRAKING DISTANCE IS LONG

< SYMPTOM DIAGNOSIS >

[ABS]

## THE BRAKING DISTANCE IS LONG

### Diagnosis Procedure

INFOID:000000001600974

#### **CAUTION:**

The stopping distance on slippery road surfaces might be longer with the ABS operating than when the ABS is not operating.

#### **1**.CHECK FUNCTION

Turn ignition switch OFF and disconnect ABS actuator and electric unit (control unit) connector to deactivate ABS. In this condition, check stopping distance. After inspection, connect connector.

Is the inspection result normal?

YES >> Normal

NO >> Check brake system.

A  
B  
C  
D  
E  
G  
H  
I  
J  
K  
L  
M  
N  
O  
P

BRC

## ABS FUNCTION DOES NOT OPERATE

< SYMPTOM DIAGNOSIS >

[ABS]

---

### ABS FUNCTION DOES NOT OPERATE

#### Diagnosis Procedure

INFOID:000000001600975

**CAUTION:**

**ABS does not operate when speed is 10 km/h (6 MPH) or lower.**

**1**.CHECK ABS WARNING LAMP DISPLAY

---

Make sure that the ABS warning lamp turns OFF after ignition switch is turned ON or when driving.

Is the inspection result normal?

YES >> Normal

NO >> Perform self-diagnosis. Refer to [BRC-16, "CONSULT-III Function \(ABS\)"](#).



# PEDAL VIBRATION OR ABS OPERATION SOUND OCCURS

[ABS]

< SYMPTOM DIAGNOSIS >

## PEDAL VIBRATION OR ABS OPERATION SOUND OCCURS

### Diagnosis Procedure

INFOID:000000001600976

#### **CAUTION:**

Under the following conditions, ABS is activated and vibration is felt when brake pedal is lightly depressed. However, this is normal.

- When shifting gears
- When driving on slippery road
- During cornering at high speed
- When passing over bumps or grooves [at approximately 50 mm (1.97 in) or more]
- When pulling away just after starting engine [at approximately 10 km/h (6 MPH) or higher]

### 1. SYMPTOM CHECK 1

Check that there are pedal vibrations when the engine is started.

Do vibrations occur?

YES >> GO TO 2

NO >> Inspect the brake pedal.

### 2. SYMPTOM CHECK 2

Check that there are ABS operation noises when the engine is started.

Do the operation noises occur?

YES >> GO TO 3

NO >> Perform self -diagnosis. Refer to [BRC-16, "CONSULT-III Function \(ABS\)".](#)

### 3. SYMPTOM CHECK 3

Check symptoms when electrical component (headlamps, etc.) switches are operated.

Do symptoms occur?

YES >> Check if there is a radio, antenna, antenna lead wire, or wiring close to the control unit. If there is, move it farther away.

NO >> Normal

A  
B  
C  
D  
E  
F  
G  
H  
I  
J  
K  
L  
M  
N  
O  
P

BRC

# NORMAL OPERATING CONDITION

< SYMPTOM DIAGNOSIS >

[ABS]

## NORMAL OPERATING CONDITION

### Description

INFOID:000000001600978

Symptom	Result
Slight vibrations are felt on the brake pedal and the operation noises occur, when ABS is activated.	This is a normal condition due to the ABS activation.
Stopping distance is longer than that of vehicles without ABS when the vehicle drives on rough, gravel, or snow-covered (fresh, deep snow) roads.	
The brake pedal vibrates and motor operation noises occur from the engine room, after the engine starts and just after the vehicle starts.	This is normal, and it is caused by the ABS operation check.

PRECAUTION

PRECAUTIONS

Precaution for Supplemental Restraint System (SRS) "AIR BAG" and "SEAT BELT PRE-TENSIONER"

INFOID:000000001600979

The Supplemental Restraint System such as "AIR BAG" and "SEAT BELT PRE-TENSIONER", used along with a front seat belt, helps to reduce the risk or severity of injury to the driver and front passenger for certain types of collision. This system includes seat belt switch inputs and dual stage front air bag modules. The SRS system uses the seat belt switches to determine the front air bag deployment, and may only deploy one front air bag, depending on the severity of a collision and whether the front occupants are belted or unbelted. Information necessary to service the system safely is included in the SR and SB section of this Service Manual.

**WARNING:**

- To avoid rendering the SRS inoperative, which could increase the risk of personal injury or death in the event of a collision which would result in air bag inflation, all maintenance must be performed by an authorized NISSAN/INFINITI dealer.
- Improper maintenance, including incorrect removal and installation of the SRS, can lead to personal injury caused by unintentional activation of the system. For removal of Spiral Cable and Air Bag Module, see the SR section.
- Do not use electrical test equipment on any circuit related to the SRS unless instructed to in this Service Manual. SRS wiring harnesses can be identified by yellow and/or orange harnesses or harness connectors.

Precaution for Brake System

INFOID:000000001600980

**CAUTION:**

- Always use recommended brake fluid. Refer to [MA-10, "Fluids and Lubricants"](#).
- Never reuse drained brake fluid.
- Be careful not to splash brake fluid on painted areas; it may cause paint damage. If brake fluid is splashed on painted areas, wash it away with water immediately.
- To clean or wash all parts of master cylinder and disc brake caliper, use clean brake fluid.
- Never use mineral oils such as gasoline or kerosene. They will ruin rubber parts of the hydraulic system.
- Use flare nut wrench when removing and installing brake tube.
- If a brake fluid leak is found, the part must be disassembled without fail. Then it has to be replaced with a new one if a defect exists.
- Turn the ignition switch OFF and remove the connector of the ABS actuator and electric unit (control unit) or the battery terminal before performing the work.
- Always torque brake lines when installing.
- Burnish the brake contact surfaces after refinishing or replacing rotors, after replacing pads, or if a soft pedal occurs at very low mileage.

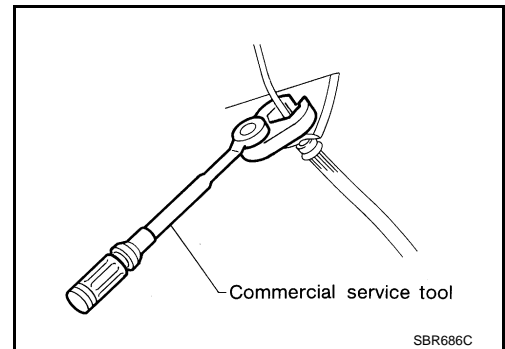

A  
B  
C  
D  
E  
BRC  
G  
H  
I  
J  
K  
L  
M  
N  
O  
P

BRC

O

P

P

Refer to [BR-35, "Brake Burnishing Procedure"](#) (front disc brake) or [BR-40, "Removal and Installation of Brake Pad"](#) (rear disc brake).

**WARNING:**

- Clean brake pads and shoes with a waste cloth, then wipe with a dust collector.

Precaution for Brake Control

INFOID:000000001600981

- During ABS operation, the brake pedal may vibrate lightly and a mechanical noise may be heard. This is normal.
- Just after starting vehicle, the brake pedal may vibrate or a motor operating noise may be heard from engine compartment. This is a normal status of operation check.
- Stopping distance may be longer than that of vehicles without ABS when vehicle drives on rough, gravel, or snow-covered (fresh, deep snow) roads.

# PRECAUTIONS

[ABS]

## < PRECAUTION >

- When an error is indicated by ABS or another warning lamp, collect all necessary information from customer (what symptoms are present under what conditions) and check for simple causes before starting diagnosis. Besides electrical system inspection, check booster operation, brake fluid level, and fluid leaks.
- If incorrect tire sizes or types are installed on the vehicle or brake pads are not Genuine NISSAN parts, stopping distance or steering stability may deteriorate.
- If there is a radio, antenna or related wiring near control module, ABS function may have a malfunction or error.
- If aftermarket parts (car stereo, CD player, etc.) have been installed, check for incidents such as harness pinches, open circuits or improper wiring.

## Precaution for CAN System

INFOID:000000001600982

- Do not apply voltage of 7.0V or higher to terminal to be measured.
- Maximum open terminal voltage of tester in use must be less than 7.0V.
- Before checking harnesses, turn ignition switch OFF and disconnect battery negative cable.
- Area to be repaired must be soldered and wrapped with tape. Make sure that fraying of twisted wire is within 110 mm (4.33 in).

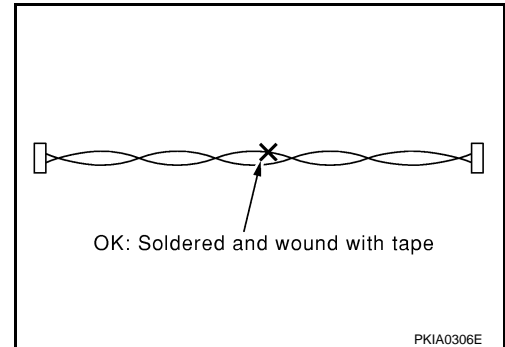

- Do not make a bypass connection to repaired area. (If the circuit is bypassed, characteristics of twisted wire will be lost.)

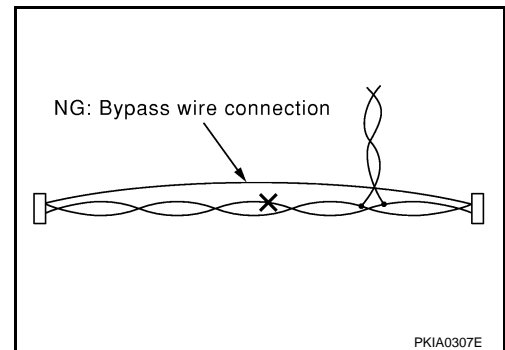

# PREPARATION

< PREPARATION >

[ABS]

## PREPARATION

### PREPARATION

#### Special Service Tool

INFOID:000000001601793

The actual shapes of Kent-Moore tools may differ from those of special service tools illustrated here.

Tool number (Kent-Moore No.) Tool name	Description
— (J-45741) ABS active wheel sensor tester	Checking operation of ABS active wheel sensors
ST30031000 ( — ) Bearing splitter	Removing axle shaft bearing

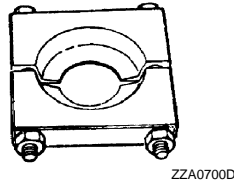
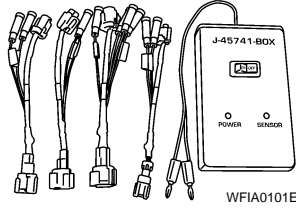

#### Commercial Service Tool

INFOID:000000001601794

Tool name	Description
1. Flare nut crowfoot 2. Torque wrench	Removing and installing brake piping a: 10mm (0.39 in)/12mm (0.47 in)

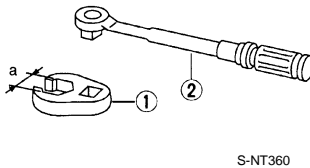

# WHEEL SENSORS

< REMOVAL AND INSTALLATION >

[ABS]

## REMOVAL AND INSTALLATION

### WHEEL SENSORS

#### Removal and Installation

INFOID:000000001601795

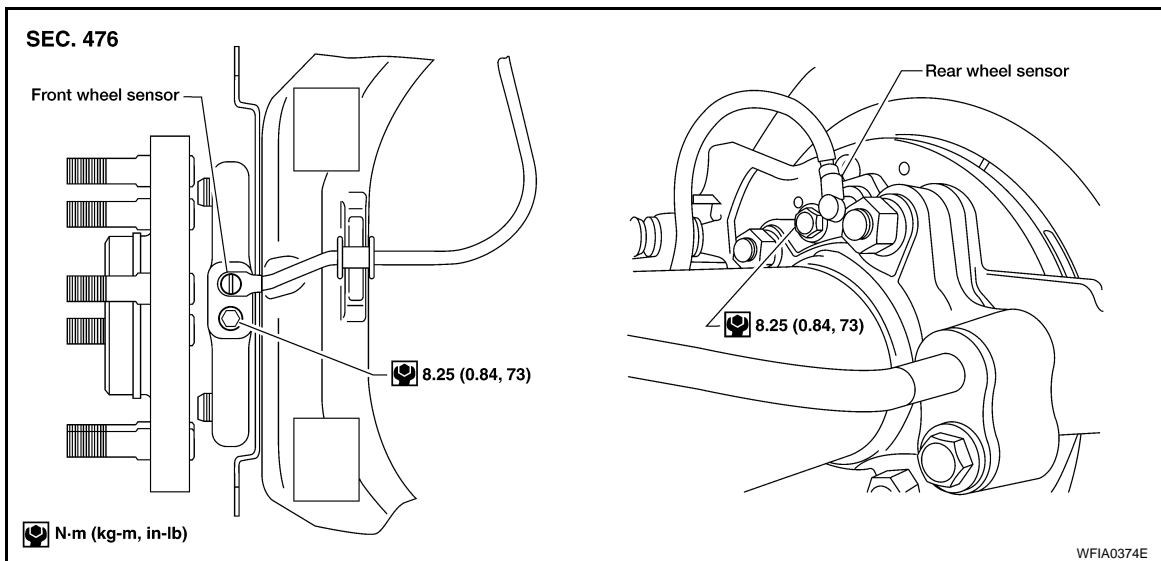

#### REMOVAL

1. Remove wheel sensor bolt.
  - When removing the front wheel sensor, first remove the disc rotor to gain access to the front wheel sensor bolt. Refer to [BR-34, "Removal and Installation of Brake Caliper and Disc Rotor"](#).
2. Pull out the sensor, being careful to turn it as little as possible.

**CAUTION:**

  - Be careful not to damage sensor edge and sensor rotor teeth.
  - Do not pull on the sensor harness.
3. Disconnect wheel sensor harness electrical connector, then remove harness from mounts.

#### INSTALLATION

Installation is in the reverse order of removal. Tighten wheel sensor bolt to specification.

**CAUTION:**

Installation should be performed while paying attention to the following:

- Inspect wheel sensor O-ring, replace sensor assembly if damaged.
- Clean wheel sensor hole and mounting surface with brake cleaner and a lint-free shop rag. Be careful that dirt and debris do not enter the axle.
- Apply a coat of suitable grease to the wheel sensor O-ring and mounting hole. Refer to [MA-10, "Fluids and Lubricants"](#).

# SENSOR ROTOR

< REMOVAL AND INSTALLATION >

[ABS]

## SENSOR ROTOR

### Removal and Installation

INFOID:000000001601796

#### FRONT

The wheel sensor rotors are built into the wheel hubs and are not removable. If damaged, replace wheel hub and bearing assembly. Refer to [FAX-6, "Removal and Installation"](#).

#### REAR

##### Removal

1. Remove axle shaft assembly. Refer to [RAX-8, "Removal and Installation"](#).

**NOTE:**

It is necessary to disassemble the rear axle to replace the sensor rotor.

2. Pull the sensor rotor off the axle shaft using Tool and a press.

**Tool number** : ST30031000 ( — )

##### Installation

1. Install new sensor rotor on axle shaft using a suitable length steel tube and a press. Make sure sensor rotor is fully seated.

**CAUTION:**

**Do not reuse the old sensor rotor.**

2. Install axle shaft assembly. Refer to [RAX-8, "Removal and Installation"](#).

**CAUTION:**

**Do not reuse the axle oil seal. The axle oil seal must be replaced every time the axle shaft assembly is removed from the axle shaft housing.**

A

B

C

D

E

BRC

G

H

I

J

K

L

M

N

O

P

# ACTUATOR AND ELECTRIC UNIT (ASSEMBLY)

< REMOVAL AND INSTALLATION >

[ABS]

## ACTUATOR AND ELECTRIC UNIT (ASSEMBLY)

### Removal and Installation

INFOID:000000001601797

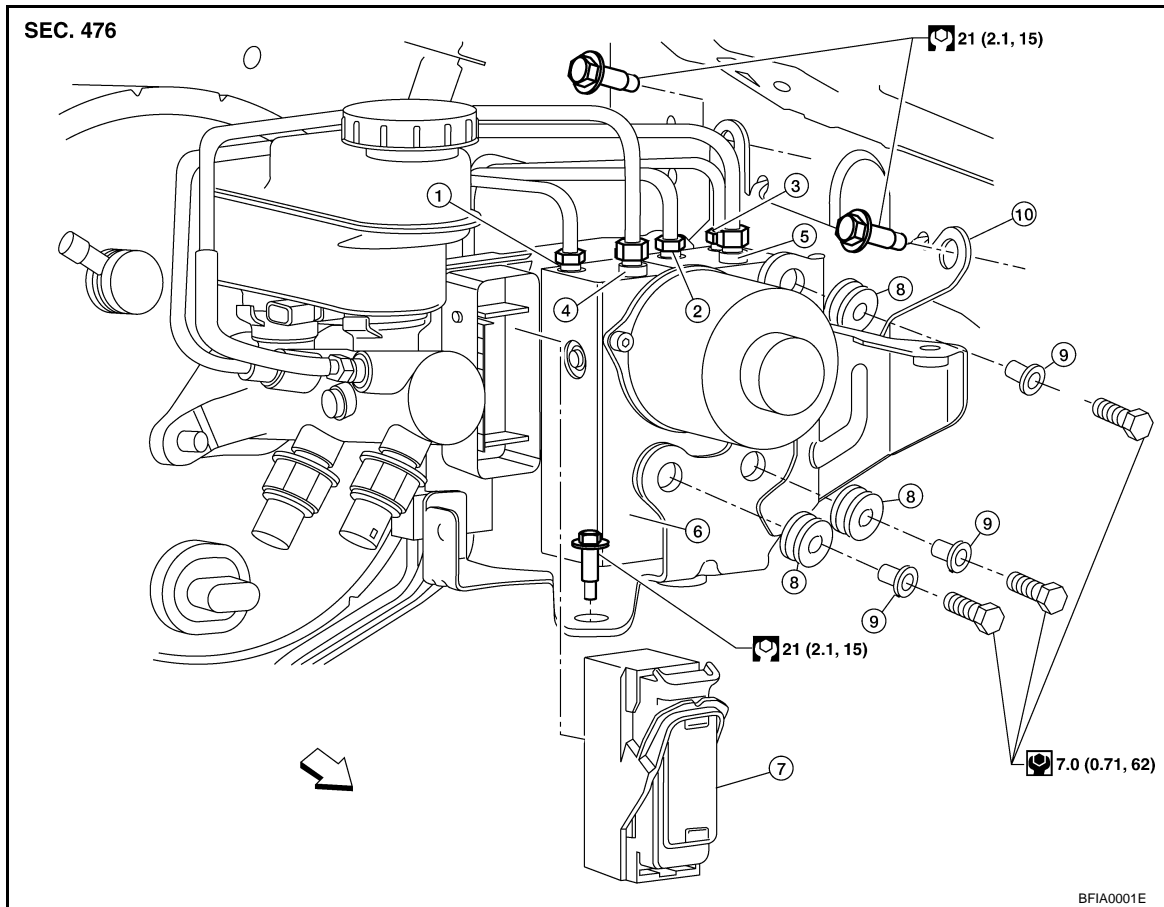

- |  |   |  |
|--|---|--|
| 1. Brake tube to rear left cylinder body   | 2. Brake tube to front left cylinder body | 3. Brake tube to front right cylinder body       |
| 4. From the master cylinder secondary side | 5. From the master cylinder primary side  | 6. ABS actuator and electric unit (control unit) |
| 7. Harness connector                       | 8. Grommet                                | 9. Collar  |
| 10. Bracket                                | ←: Front                                  |  |

### REMOVAL

1. Disconnect the battery negative terminal.
2. Remove the cowl top extension. Refer to [EXT-19. "Removal and Installation"](#).
3. Drain the brake fluid. Refer to [BR-16. "Drain and Refill"](#).
4. Disconnect the actuator harness connector from the ABS actuator and electric unit (control unit).

#### CAUTION:

- To remove the brake tubes, use a flare nut crowfoot and torque wrench to prevent the flare nuts and brake tubes from being damaged.
- Be careful not to splash brake fluid on painted areas; it may cause paint damage. If brake fluid is splashed on painted areas, wash it away with water immediately.

5. Disconnect the brake tubes.
6. Remove the three bolts and remove the ABS actuator and electric unit (control unit).

### INSTALLATION

Installation is in the reverse order of removal.

#### NOTE:



# ACTUATOR AND ELECTRIC UNIT (ASSEMBLY)

[ABS]

## < REMOVAL AND INSTALLATION >

To install, use a flare nut crowfoot and torque wrench. Tighten brake tubes to specification when installing. Refer to [BR-12, "Hydraulic Circuit"](#).

- After installation of the ABS actuator and electric unit (control unit), refill the brake system with new brake fluid. Refer to [MA-10, "Fluids and Lubricants"](#). Then bleed the air from the system. Refer to [BR-16, "Bleeding Brake System"](#).

**CAUTION:**

- **Never reuse drained brake fluid.**

A  
B  
C  
D  
E  
G  
H  
I  
J  
K  
L  
M  
N  
O  
P

BRC

# DIAGNOSIS AND REPAIR WORKFLOW

< BASIC INSPECTION >

[ABLS/ABS]

## BASIC INSPECTION

### DIAGNOSIS AND REPAIR WORKFLOW

Work Flow

INFOID:000000001600983

#### OVERALL SEQUENCE

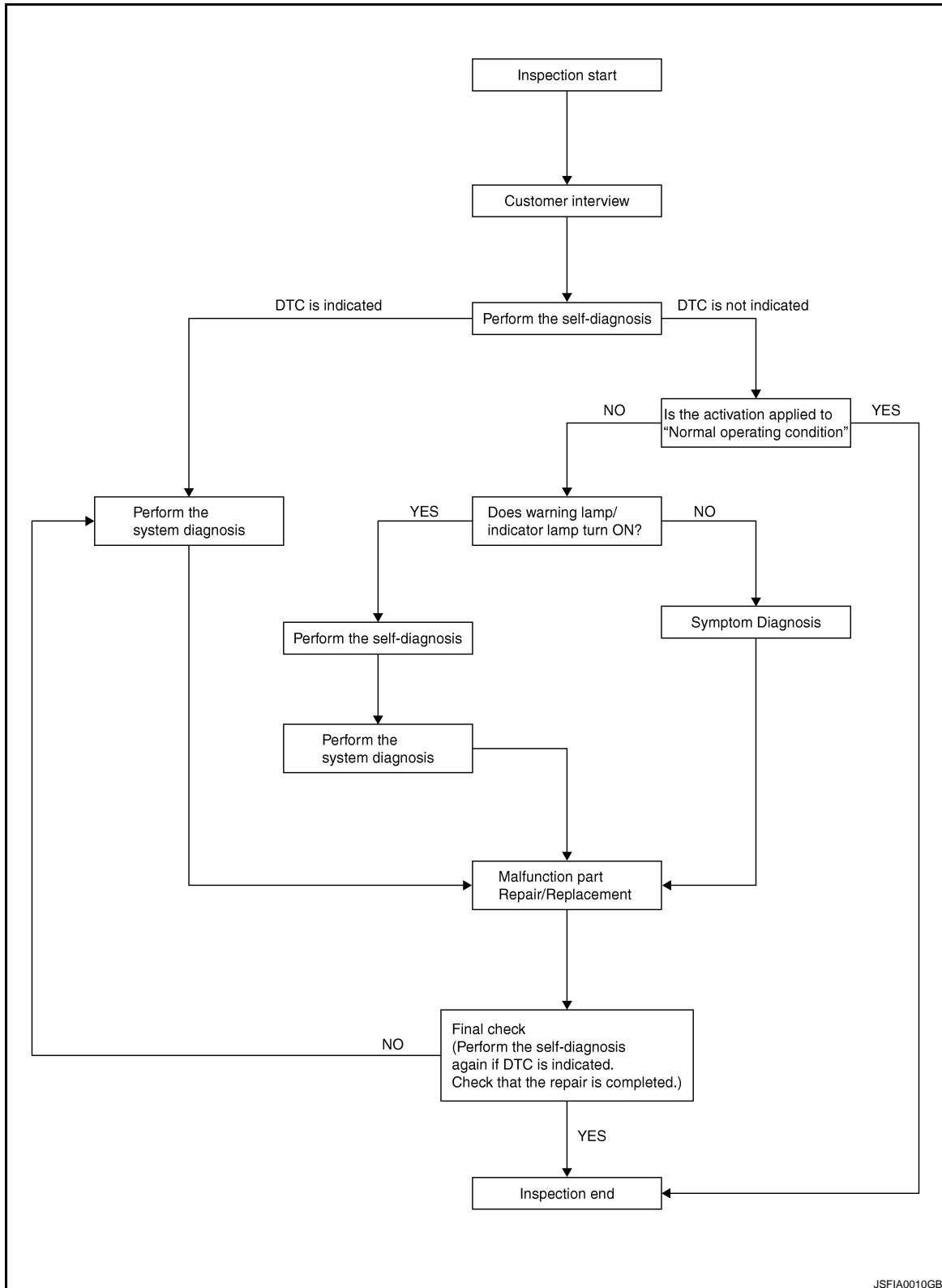

JSFIA0010GB

DETAILED FLOW

# DIAGNOSIS AND REPAIR WORKFLOW

[ABLS/ABS]

< BASIC INSPECTION >

## 1. COLLECT THE INFORMATION FROM THE CUSTOMER

Get the detailed information from the customer about the symptom (the condition and the environment when the incident/malfunction occurred) using the diagnosis worksheet. Refer to [BRC-68, "Diagnostic Work Sheet"](#).

>> GO TO 2

## 2. PERFORM THE SELF-DIAGNOSIS

Check the DTC display with the self-diagnosis function. Refer to [BRC-78, "CONSULT-III Function \(ABS\)"](#).

Is there any DTC displayed?

YES >> GO TO 3

NO >> GO TO 4

## 3. PERFORM THE SYSTEM DIAGNOSIS

Perform the diagnosis applicable to the displayed DTC. Refer to [BRC-130, "DTC No. Index"](#).

>> GO TO 7

## 4. CHECK THE SYMPTOM THAT IS NOT CONSIDERED A SYSTEM MALFUNCTION

Check that the symptom is a normal operation that is not considered a system malfunction. Refer to [BRC-138, "Description"](#).

Is the symptom a normal operation?

YES >> INSPECTION END

NO >> GO TO 5

## 5. CHECK THE WARNING LAMP AND INDICATOR LAMP FOR ILLUMINATION

Check that the warning lamp and indicator lamp illuminate.

- ABS warning lamp: Refer to [BRC-116, "Description"](#).
- Brake warning lamp: Refer to [BRC-117, "Description"](#).
- SLIP indicator lamp: Refer to [BRC-118, "Description"](#).

Is ON/OFF timing normal?

YES >> GO TO 6

NO >> GO TO 2

## 6. PERFORM THE DIAGNOSIS BY SYMPTOM

Perform the diagnosis applicable to the symptom.

>> GO TO 7

## 7. REPAIR OR REPLACE THE MALFUNCTIONING PARTS

Repair or replace the specified malfunctioning parts.

>> GO TO 8

## 8. FINAL CHECK

Perform the self-diagnosis again, and check that the malfunction is repaired completely. After checking, erase the self-diagnosis memory. Refer to [BRC-78, "CONSULT-III Function \(ABS\)"](#).

Is no other DTC present and the repair completed?

YES >> INSPECTION END

NO >> GO TO 3

A  
B  
C  
D  
E  
BRC  
G  
H  
I  
J  
K  
L  
M  
N  
O  
P

# DIAGNOSIS AND REPAIR WORKFLOW

< BASIC INSPECTION >

[ABLS/ABS]

## Diagnostic Work Sheet

INFOID:000000001600984

Customer name	Model & Year	VIN	
Engine #	Trans.	Mileage	
Incident Date	Manuf. Date	In Service Date	
Symptoms	<input type="checkbox"/> Noise and vibration (from engine compartment) <input type="checkbox"/> Noise and vibration (from axle)	<input type="checkbox"/> ABS warning lamp activates	<input type="checkbox"/> Pedal operation <input type="checkbox"/> Large stroke pedal operation <input type="checkbox"/> Firm pedal
	<input type="checkbox"/> ABS does not work (wheels lock when braking)	<input type="checkbox"/> ABS does not work (wheels slip when braking)	<input type="checkbox"/> Lack of sense of acceleration
Engine conditions	<input type="checkbox"/> When starting <input type="checkbox"/> After starting		
Road conditions	<input type="checkbox"/> Low friction road ( <input type="checkbox"/> Snow <input type="checkbox"/> Gravel <input type="checkbox"/> Other ) <input type="checkbox"/> Bumps/potholes		
Driving conditions	<input type="checkbox"/> Full-acceleration <input type="checkbox"/> High speed cornering <input type="checkbox"/> Vehicle speed: Greater than 10 km/h (6 MPH) <input type="checkbox"/> Vehicle speed: 10 km/h (6 MPH) or less <input type="checkbox"/> Vehicle is stopped		
Applying brake conditions	<input type="checkbox"/> Suddenly <input type="checkbox"/> Gradually		
Other conditions	<input type="checkbox"/> Operation of electrical equipment <input type="checkbox"/> Shift change <input type="checkbox"/> Other descriptions		

WFIA0226E

# FUNCTION DIAGNOSIS

## ABLS

### System Diagram

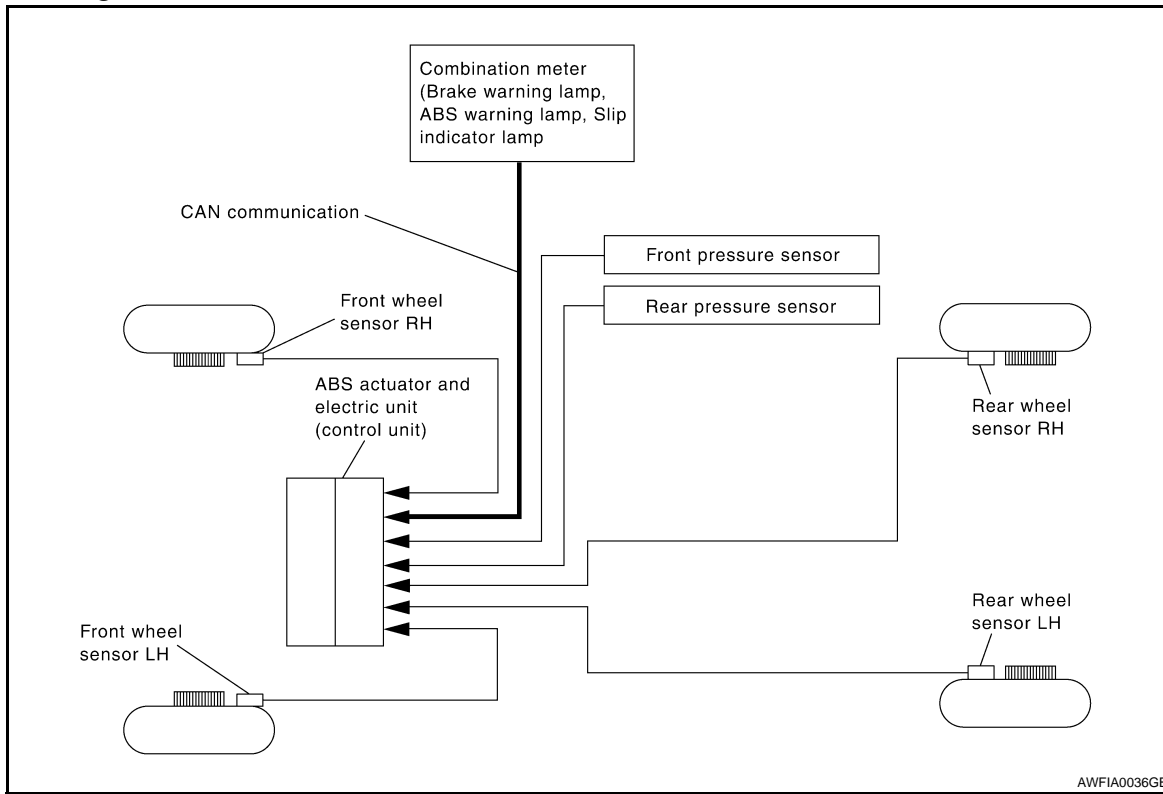

### System Description

INFOID:000000001600996

- Active brake limited slip is a function to improve vehicle traction. Spinning of the drive wheels is detected by the ABS actuator and electric unit (control unit) using inputs from the wheel speed sensors. If wheel spin occurs, the ABLs system brakes the spinning wheel which distributes the driving power to the other drive wheel.
- During ABLs operation, it informs driver of system operation by flashing SLIP indicator lamp.
- Electrical system diagnosis by CONSULT-III is available.

A  
B  
C  
D  
E  
BRC  
G  
H  
I  
J  
K  
L  
M  
N  
O  
P

Component Parts Location

INFOID:000000001600997

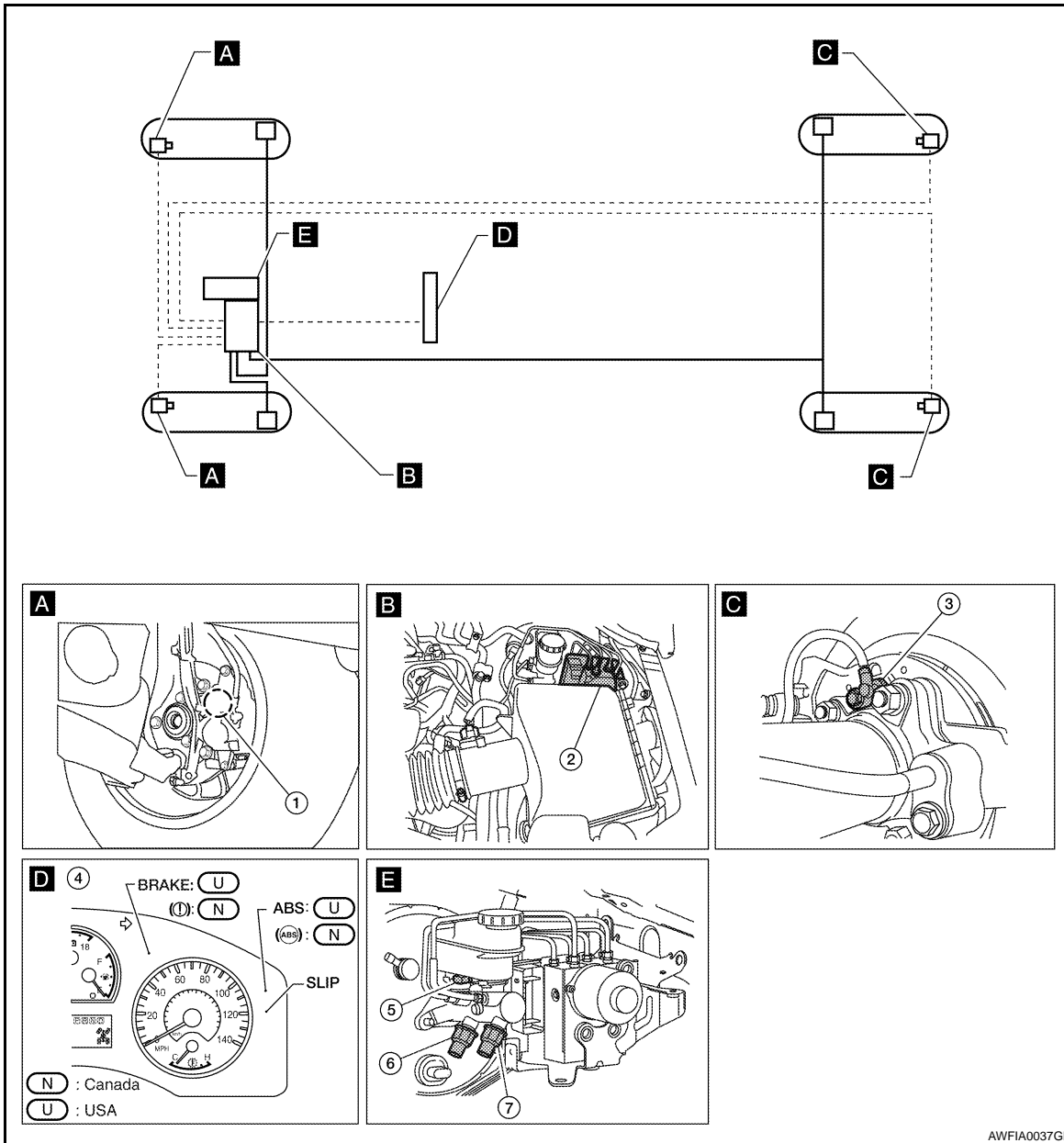

AWFIA0037GE

- |  |   |  |
|--|---|--|
| 1. Front wheel sensor<br>LH E18<br>RH E117 | 2. ABS actuator and electric unit (control unit) E125 | 3. Rear wheel sensor<br>LH C11<br>RH C10 |
| 4. Combination meter M24, M25              | 5. Brake fluid level switch E21                       | 6. Front pressure sensor E31             |
| 7. Rear pressure sensor E32                |   |  |

# ABLS

[ABLS/ABS]

< FUNCTION DIAGNOSIS >

## Component Description

INFOID:000000001600998

Component parts		Reference
ABS actuator and electric unit (control unit)	Pump	<a href="#">BRC-91, "Description"</a>
	Motor	
	Actuator relay	<a href="#">BRC-104, "Description"</a>
	Solenoid valve	<a href="#">BRC-97, "Description"</a>
	Switch-over valve (CV1, CV2, SV1, SV2)	<a href="#">BRC-111, "Description"</a>
Wheel sensor	<a href="#">BRC-82, "Description"</a>	
ABS warning lamp	<a href="#">BRC-116, "Description"</a>	
Brake warning lamp	<a href="#">BRC-117, "Description"</a>	
SLIP indicator lamp	<a href="#">BRC-118, "Description"</a>	
Front pressure sensor	<a href="#">BRC-106, "Description"</a>	
Rear pressure sensor		

A  
B  
C  
D  
E  
BRC  
G  
H  
I  
J  
K  
L  
M  
N  
O  
P

ABS

System Diagram

INFOID:000000001600999

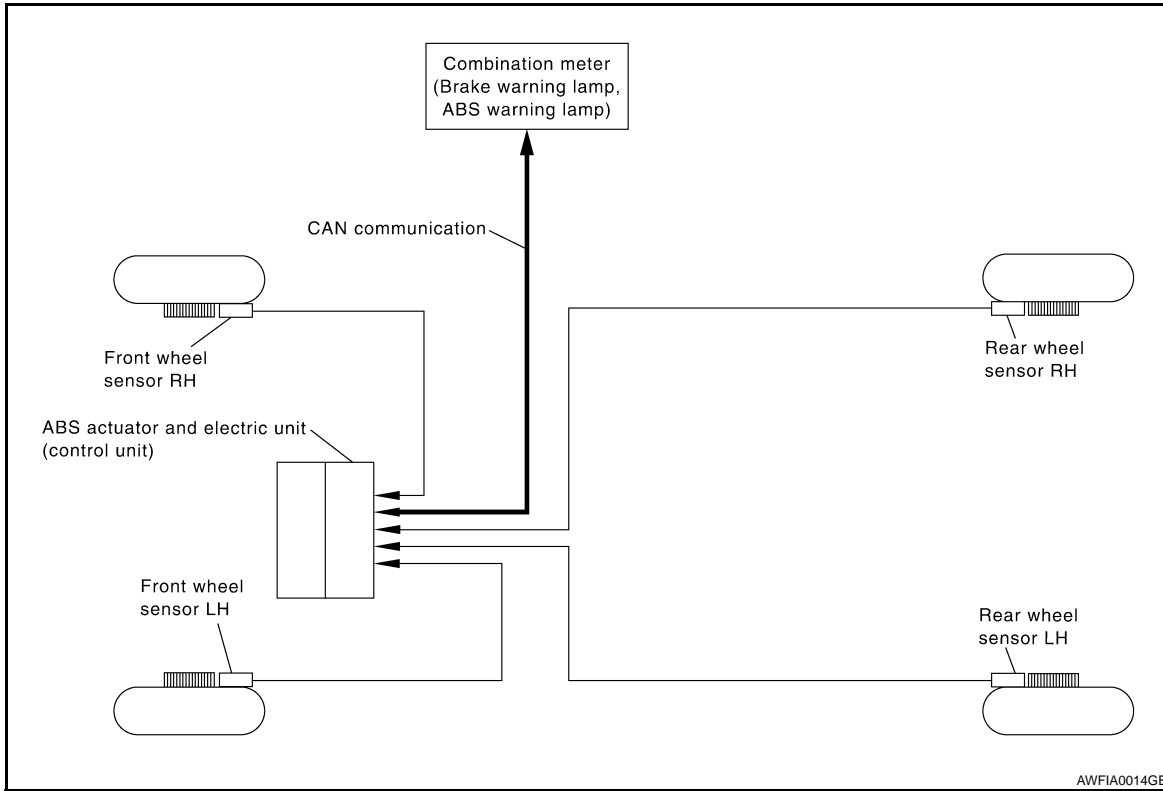

System Description

INFOID:000000001601000

- Anti-Lock Braking System is a function that detects wheel revolution while braking, electronically controls braking force, and prevents wheel locking during sudden braking. It improves handling stability and maneuverability for avoiding obstacles.
- Electrical system diagnosis by CONSULT-III is available.



Component Parts Location

INFOID:000000001677595

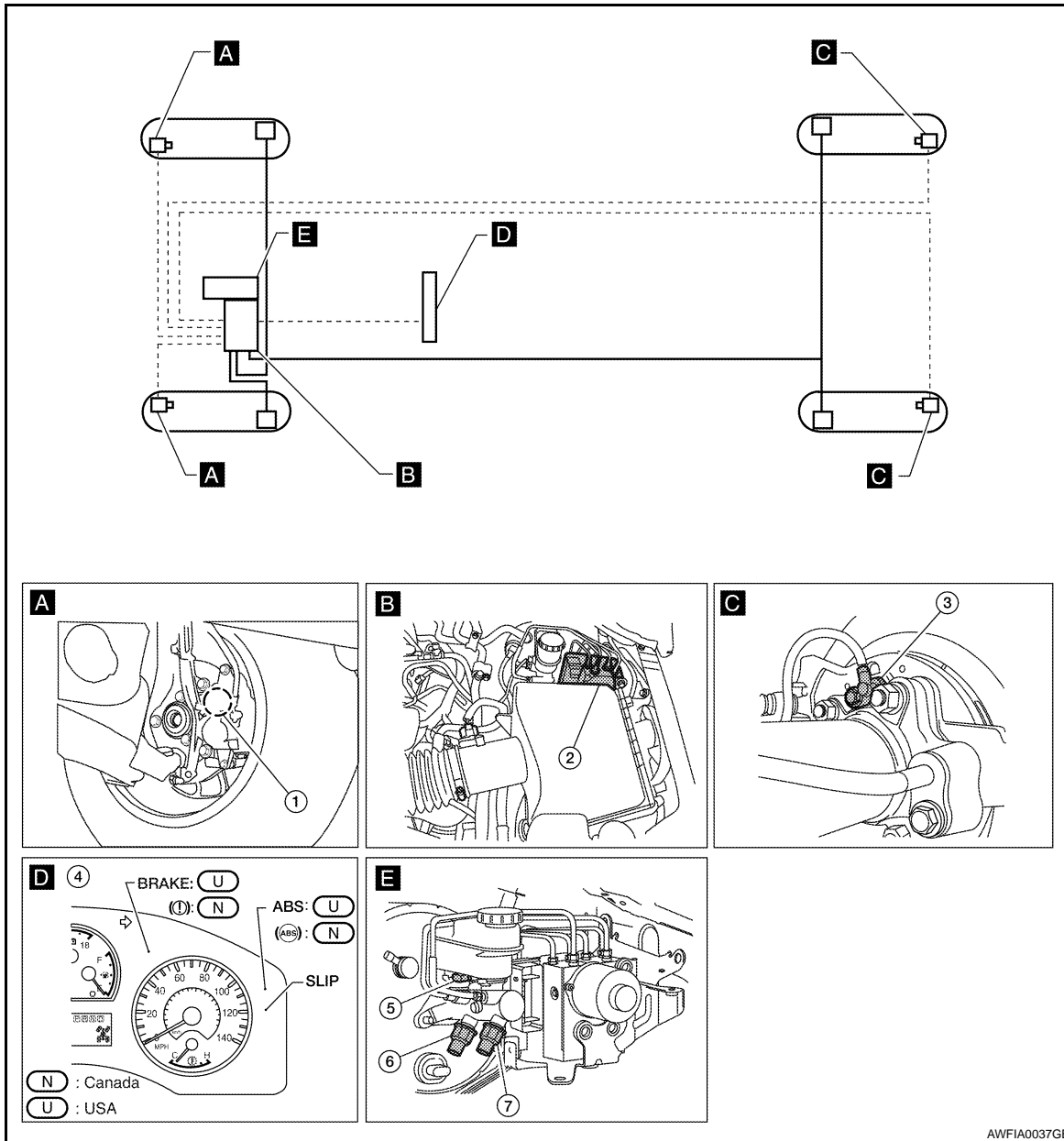

A  
B  
C  
D  
E  
BRC  
G  
H  
I  
J  
K  
L  
M  
N  
O  
P

- 1. Front wheel sensor  
LH E18  
RH E117
- 2. ABS actuator and electric unit (control unit) E125
- 3. Rear wheel sensor  
LH C11  
RH C10
- 4. Combination meter M24, M25
- 5. Brake fluid level switch E21
- 6. Front pressure sensor E31
- 7. Rear pressure sensor E32

Component Description

INFOID:000000001601002

Component parts		Reference
ABS actuator and electric unit (control unit)	Pump	<a href="#">BRC-91, "Description"</a>
	Motor	
	Actuator relay	<a href="#">BRC-104, "Description"</a>
	Solenoid valve	<a href="#">BRC-97, "Description"</a>

# ABS

[ABLS/ABS]

< FUNCTION DIAGNOSIS >

Component parts	Reference
Wheel sensor	<a href="#">BRC-82. "Description"</a>
ABS warning lamp	<a href="#">BRC-116. "Description"</a>
Brake warning lamp	<a href="#">BRC-117. "Description"</a>

EBD

System Diagram

INFOID:000000001677596

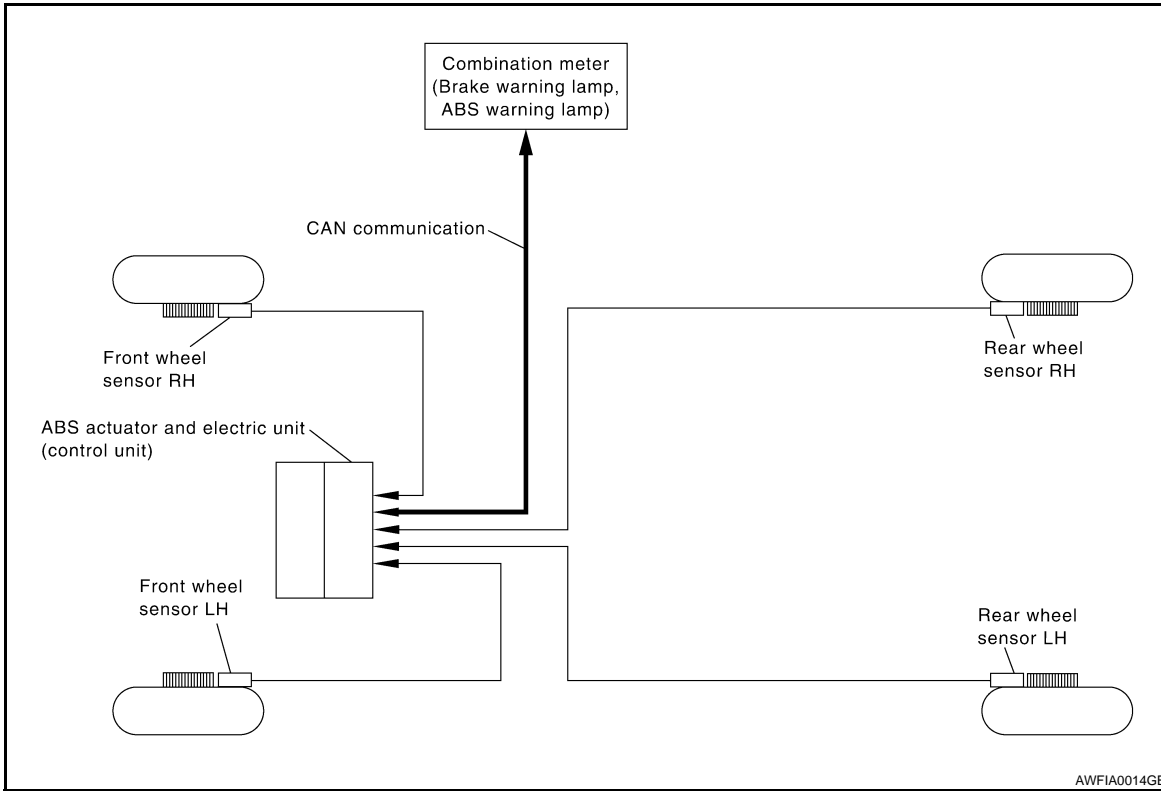

A  
B  
C  
D  
E  
BRC  
G  
H  
I  
J  
K  
L  
M  
N  
O  
P

System Description

INFOID:000000001601004

- Electric Brake force Distribution is a following function. ABS actuator and electric unit (control unit) detects subtle slippages between the front and rear wheels during braking. Then it electronically controls the rear braking force (brake fluid pressure) to reduce rear wheel slippage. Accordingly, it improves vehicle stability.
- Electrical system diagnosis by CONSULT-III is available.

Component Parts Location

INFOID:000000001677597

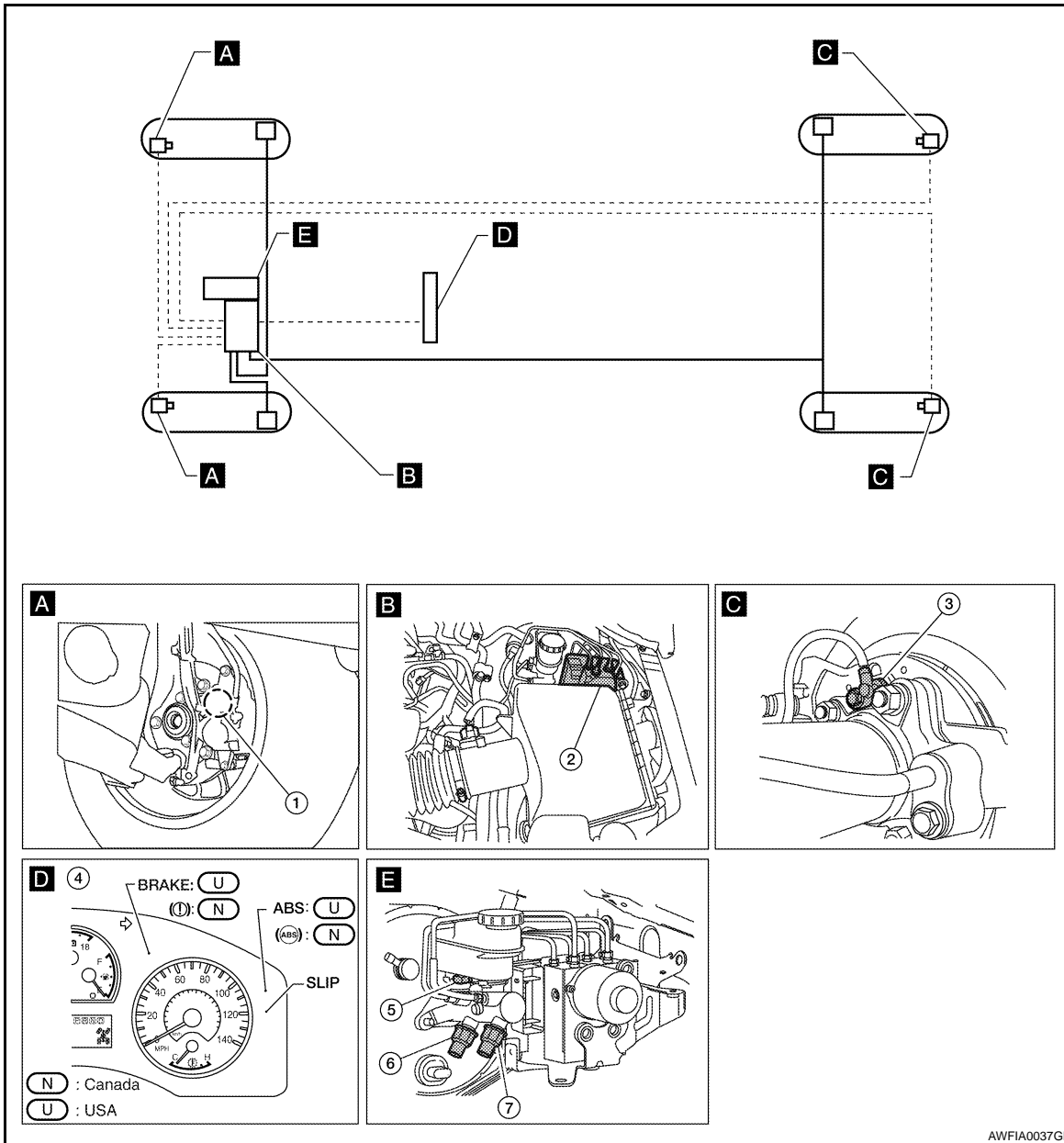

AWFIA0037GE

- |  |   |  |
|--|---|--|
| 1. Front wheel sensor<br>LH E18<br>RH E117 | 2. ABS actuator and electric unit (control unit) E125 | 3. Rear wheel sensor<br>LH C11<br>RH C10 |
| 4. Combination meter M24, M25              | 5. Brake fluid level switch E21                       | 6. Front pressure sensor E31             |
| 7. Rear pressure sensor E32                |   |  |

Component Description

INFOID:000000001677598

Component parts		Reference
ABS actuator and electric unit (control unit)	Pump	<a href="#">BRC-91. "Description"</a>
	Motor	
	Actuator relay	<a href="#">BRC-104. "Description"</a>
	Solenoid valve	<a href="#">BRC-97. "Description"</a>

# EBD

[ABLS/ABS]

< FUNCTION DIAGNOSIS >

Component parts	Reference
Wheel sensor	<a href="#">BRC-82. "Description"</a>
ABS warning lamp	<a href="#">BRC-116. "Description"</a>
Brake warning lamp	<a href="#">BRC-117. "Description"</a>

A

B

C

D

E

**BRC**

G

H

I

J

K

L

M

N

O

P

# DIAGNOSIS SYSTEM [ABS ACTUATOR AND ELECTRIC UNIT (CONTROL UNIT)]

< FUNCTION DIAGNOSIS >

[ABLS/ABS]

## DIAGNOSIS SYSTEM [ABS ACTUATOR AND ELECTRIC UNIT (CONTROL UNIT)]

### CONSULT-III Function (ABS)

INFOID:000000001601007

#### FUNCTION

CONSULT-III can display each diagnostic item using the diagnostic test modes shown following.

Diagnostic test mode	Function
Work support	This mode enables a technician to adjust some devices faster and more accurately by following the indications on CONSULT-III.
Self-diagnostic results	Self-diagnostic results can be read and erased quickly.
Data monitor	Input/Output data in the ABS actuator and electric unit (control unit) can be read.
Active test	Diagnostic test mode is which CONSULT-III drives some actuators apart from the ABS actuator and electric unit (control unit) and also shifts some parameters in a specified range.
ECU part number	ABS actuator and electric unit (control unit) part number can be read.
CAN diagnostic support monitor	The results of transmit/receive diagnosis of CAN communication can be read.

#### SELF-DIAG RESULTS MODE

##### Operation Procedure

1. Before performing the self-diagnosis, start engine and drive vehicle at 30 km/h (19 MPH) or more for approximately 1 minute.

##### How to Erase Self-diagnosis Results

1. After erasing DTC memory, start engine and drive vehicle at 30 km/h (19 MPH) or more for approximately 1 minute as the final inspection, and make sure that the ABS warning lamp and brake warning lamp turn OFF.

##### **CAUTION:**

**If memory cannot be erased, perform applicable diagnosis.**

##### **NOTE:**

- When the wheel sensor malfunctions, after inspecting the wheel sensor system, the ABS warning lamp and brake warning lamp will not turn OFF even when the system is normal unless the vehicle is driving at approximately 30 km/h (19 MPH) or more for approximately 1 minute.
- Brake warning lamp will turn ON in case of parking brake operation (when switch is ON) or of brake fluid level switch operation (when brake fluid is insufficient).

##### Display Item List

Refer to [BRC-130, "DTC No. Index"](#).

#### DATA MONITOR MODE

##### Display Item List

Item (Unit)	Data monitor item selection			Remarks
	ECU INPUT SIGNALS	MAIN SIGNALS	SELECTION FROM MENU	
GEAR	×	×	×	Gear position judged by PNP switch signal is displayed.
FR RH SENSOR (km/h, MPH)	×	×	×	Wheel speed calculated by front RH wheel sensor signal is displayed.
FR LH SENSOR (km/h, MPH)	×	×	×	Wheel speed calculated by front LH wheel sensor signal is displayed.
RR RH SENSOR (km/h, MPH)	×	×	×	Wheel speed calculated by rear RH wheel sensor signal is displayed.
RR LH SENSOR (km/h, MPH)	×	×	×	Wheel speed calculated by rear LH wheel sensor signal is displayed.

# DIAGNOSIS SYSTEM [ABS ACTUATOR AND ELECTRIC UNIT (CONTROL UNIT)]

< FUNCTION DIAGNOSIS >

[ABLS/ABS]

Item (Unit)	Data monitor item selection			Remarks
	ECU INPUT SIGNALS	MAIN SIGNALS	SELECTION FROM MENU	
BATTERY VOLT (V)	×	×	×	Voltage supplied to ABS actuator and electric unit (control unit) is displayed.
N POSI SIG	-	-	×	Shift position judged by PNP switch signal.
P POSI SIG	-	-	×	Shift position judged by PNP switch signal.
ACCEL POS SIG (%)	×	-	×	Throttle valve open/close status judged by CAN communication signal is displayed.
ENGINE SPEED (rpm)	×	×	×	Engine speed judged by CAN communication signal is displayed.
DECEL G-SEN (d/s)	×	×	×	Longitudinal acceleration detected by decel G-sensor is displayed.
STOP LAMP SW (ON/OFF)	×	×	×	Stop lamp switch (ON/OFF) status is displayed.
ABS WARN LAMP (ON/OFF)	-	×	×	ABS warning lamp (ON/OFF) status is displayed.
SLIP LAMP (ON/OFF)	-	×	×	SLIP indicator lamp (ON/OFF) status is displayed.
FR LH IN SOL (ON/OFF)	-	×	×	Front LH IN ABS solenoid (ON/OFF) status is displayed.
FR LH OUT SOL (ON/OFF)	-	×	×	Front LH OUT ABS solenoid (ON/OFF) status is displayed.
RR RH IN SOL (ON/OFF)	-	×	×	Rear RH IN ABS solenoid (ON/OFF) status is displayed.
RR RH OUT SOL (ON/OFF)	-	×	×	Rear RH OUT ABS solenoid (ON/OFF) status is displayed.
FR RH IN SOL (ON/OFF)	-	×	×	Front RH IN ABS solenoid (ON/OFF) status is displayed.
FR RH OUT SOL (ON/OFF)	-	×	×	Front RH OUT ABS solenoid (ON/OFF) status is displayed.
RR LH IN SOL (ON/OFF)	-	×	×	Rear LH IN ABS solenoid (ON/OFF) status is displayed.
RR LH OUT SOL (ON/OFF)	-	×	×	Rear LH OUT ABS solenoid (ON/OFF) status is displayed.
MOTOR RELAY (ON/OFF)	-	×	×	ABS motor relay signal (ON/OFF) status is displayed.
ACTUATOR RLY (ON/OFF)	-	×	×	ABS actuator relay signal (ON/OFF) status is displayed.
CV1 (ON/OFF)	-	-	×	Front side switch-over solenoid valve (cut valve) (ON/OFF) status is displayed.
CV2 (ON/OFF)	-	-	×	Rear side switch-over solenoid valve (cut-valve) (ON/OFF) status is displayed.
SV1 (ON/OFF)	-	-	×	Front side switch-over solenoid valve (suction valve) (ON/OFF) status is displayed.
SV2 (ON/OFF)	-	-	×	Rear side switch-over solenoid valve (suction valve) (ON/OFF) status is displayed.

A

B

C

D

E

BRC

G

H

I

J

K

L

M

N

O

P

# DIAGNOSIS SYSTEM [ABS ACTUATOR AND ELECTRIC UNIT (CONTROL UNIT)]

< FUNCTION DIAGNOSIS >

[ABLS/ABS]

Item (Unit)	Data monitor item selection			Remarks
	ECU INPUT SIGNALS	MAIN SIGNALS	SELECTION FROM MENU	
TCS FAIL SIG (ON/OFF)	-	-	×	ABLS fail signal (ON/OFF) status is displayed.
ABS FAIL SIG (ON/OFF)	-	-	×	ABS fail signal (ON/OFF) status is displayed.
EBD FAIL SIG (ON/OFF)	-	-	×	EBD fail signal (ON/OFF) status is displayed.
FLUID LEV SW (ON/OFF)	×	-	×	Brake fluid level switch (ON/OFF) status is displayed.
EBD SIGNAL (ON/OFF)	-	-	×	EBD operation (ON/OFF) status is displayed.
ABS SIGNAL (ON/OFF)	-	-	×	ABS operation (ON/OFF) status is displayed.
TCS SIGNAL (ON/OFF)	-	-	×	ABLS operation (ON/OFF) status is displayed.
EBD WARN LAMP	-	-	×	Brake warning lamp (ON/OFF) status is displayed.
SLCT LVR POSI	×	×	×	Shift position judged by PNP switch signal.
R POSI SIG	-	-	×	Shift position judged by PNP switch signal.
2WD/4WD	-	-	×	It recognizes on software whether it is 2WD and whether it is in 4WD state.
PRESS SENSOR	×	-	×	Brake pressure detected by pressure sensor is displayed.
CRANKING SIG	-	-	×	The input state of the key SW START position signal is displayed.
PRESS SEN 2	-	-	×	Brake pressure detected by pressure sensor is displayed.

×: Applicable

-: Not applicable

## ACTIVE TEST

### CAUTION:

- Do not perform active test while driving.
- Make sure to completely bleed air from the brake system.
- The ABS and brake warning lamps turn on during the active test.

### Solenoid Valve Operation Chart

Operation		ABS solenoid valve			ABS solenoid valve (ACT)		
		UP	KEEP	DOWN	UP	ACTUATOR UP	ACTUATOR KEEP
FR RH SOL FR RH ABS SOLENOID (ACT)	FR RH IN SOL	OFF	ON	ON	OFF	OFF	OFF
	FR RH OUT SOL	OFF	OFF	ON*	OFF	OFF	OFF
FR LH SOL FR LH ABS SOLENOID (ACT)	FR LH IN SOL	OFF	ON	ON	OFF	OFF	OFF
	FR LH OUT SOL	OFF	OFF	ON*	OFF	OFF	OFF
RR RH SOL RR RH ABS SOLENOID (ACT)	RR RH IN SOL	OFF	ON	ON	OFF	OFF	OFF
	RR RH OUT SOL	OFF	OFF	ON*	OFF	OFF	OFF



# DIAGNOSIS SYSTEM [ABS ACTUATOR AND ELECTRIC UNIT (CONTROL UNIT)]

< FUNCTION DIAGNOSIS >

[ABLS/ABS]

Operation		ABS solenoid valve			ABS solenoid valve (ACT)		
		UP	KEEP	DOWN	UP	ACTUA-TOR UP	ACTUA-TOR KEEP
RR LH SOL RR LH ABS SOLE- NOID (ACT)	RR LH IN SOL	OFF	ON	ON	OFF	OFF	OFF
	RR LH OUT SOL	OFF	OFF	ON*	OFF	OFF	OFF
REAR SOL	RR RH IN SOL	OFF	ON	ON	OFF	OFF	OFF
	RR RH OUT SOL	OFF	OFF	ON*	OFF	OFF	OFF
	RR LH IN SOL	OFF	ON	ON	OFF	OFF	OFF
	RR LH OUT SOL	OFF	OFF	ON*	OFF	OFF	OFF

\*: ON for 1 to 2 seconds after the touch, and then OFF

**NOTE:**

- If active test is performed with brake pedal depressed, pedal stroke may change. This is normal.
- "TEST IS STOPPED" is displayed approximately 10 seconds after operation starts.
- After "TEST IS STOPPED" is displayed, to perform test again, repeat Step 6.

**ABS Motor**

Touch "ON" and "OFF" on the screen. Check that ABS motor relay operates as shown in table below.

Operation	ON	OFF
ABS actuator relay	ON	ON
ABS motor relay	ON	OFF

**NOTE:**

- If active test is performed with brake pedal depressed, pedal stroke may change. This is normal.
- "TEST IS STOPPED" is displayed approximately 10 seconds after operation starts.

A  
B  
C  
D  
E  
G  
H  
I  
J  
K  
L  
M  
N  
O  
P

BRC

# C1101, C1102, C1103, C1104 WHEEL SENSOR-1

< COMPONENT DIAGNOSIS >

[ABLS/ABS]

## COMPONENT DIAGNOSIS

### C1101, C1102, C1103, C1104 WHEEL SENSOR-1

#### Description

INFOID:000000001601008

When the sensor rotor rotates, the magnetic field changes. It converts the magnetic field changes to current signals (rectangular wave) and transmits them to the ABS actuator and electric unit (control unit).

#### DTC Logic

INFOID:000000001601009

#### DTC DETECTION LOGIC

DTC	Display item	Malfunction detected condition	Possible cause
C1101	RR RH SENSOR-1	Circuit of rear RH wheel sensor is open. Or when the sensor power voltage is outside the standard.	<ul style="list-style-type: none"><li>• Harness or connector</li><li>• Wheel sensor</li><li>• ABS actuator and electric unit (control unit)</li></ul>
C1102	RR LH SENSOR-1	Circuit of rear LH wheel sensor is open. Or when the sensor power voltage is outside the standard.	
C1103	FR RH SENSOR-1	Circuit of front RH wheel sensor is open. Or when the sensor power voltage is outside the standard.	
C1104	FR LH SENSOR-1	Circuit of front LH wheel sensor is open. Or when the sensor power voltage is outside the standard.	

#### DTC CONFIRMATION PROCEDURE

##### 1. CHECK SELF-DIAGNOSIS RESULTS

Check the self-diagnosis results.

Self-diagnosis results
RR RH SENSOR-1
RR LH SENSOR-1
FR RH SENSOR-1
FR LH SENSOR-1

Is above displayed on the self-diagnosis display?

- YES >> Proceed to diagnosis procedure. Refer to [BRC-82. "Diagnosis Procedure"](#).  
NO >> INSPECTION END

#### Diagnosis Procedure

INFOID:000000001601010

#### **CAUTION:**

**Do not check between wheel sensor terminals.**

#### INSPECTION PROCEDURE

##### 1. CONNECTOR INSPECTION

Disconnect the ABS actuator and electric unit (control unit) connector E125 and wheel sensor of malfunctioning code.

Check the terminals for deformation, disconnection, looseness or damage.

Is the inspection result normal?

- YES >> GO TO 2  
NO >> Repair or replace as necessary.

##### 2. CHECK WHEEL SENSOR OUTPUT SIGNAL

1. Connect ABS active wheel sensor tester (J-45741) to wheel sensor using appropriate adapter.
2. Turn on the ABS active wheel sensor tester power switch.

#### **NOTE:**

The green POWER indicator should illuminate. If the POWER indicator does not illuminate, replace the battery in the ABS active wheel sensor tester before proceeding.

# C1101, C1102, C1103, C1104 WHEEL SENSOR-1

[ABLS/ABS]

## < COMPONENT DIAGNOSIS >

- Spin the wheel of the vehicle by hand and observe the red SENSOR indicator on the ABS active wheel sensor tester. The red SENSOR indicator should flash on and off to indicate an output signal.

**NOTE:**

If the red SENSOR indicator illuminates but does not flash, reverse the polarity of the tester leads and retest.

Does the ABS active wheel sensor tester detect a signal?

YES >> GO TO 3

NO >> Replace the wheel sensor. Refer to [BRC-142, "Removal and Installation"](#).

### 3.CHECK TIRES

Check for inflation pressure, wear and size of each tire.

Are tire pressure and size correct and is tire wear within specifications?

YES >> GO TO 4

NO >> Adjust tire pressure or replace tire(s).

### 4.CHECK WHEEL BEARINGS

Check wheel bearing axial end play. Refer to [FAX-5, "On-Vehicle Inspection and Service"](#) (front) or [RAX-5, "On-Vehicle Inspection"](#) (rear).

Is the inspection result normal?

YES >> GO TO 5

NO >> Repair or replace as necessary. Refer to [FAX-6, "Removal and Installation"](#) (front) or [RAX-7, "Removal and Installation"](#) (rear).

### 5.CHECK WIRING HARNESS FOR SHORT CIRCUIT

- Disconnect ABS actuator and electric unit (control unit) connector and wheel sensor connector of malfunction code No.
- Check continuity between wheel sensor harness connector terminals and ground.

**Continuity should not exist.**

Is the inspection result normal?

YES >> GO TO 6

NO >> Repair the circuit.

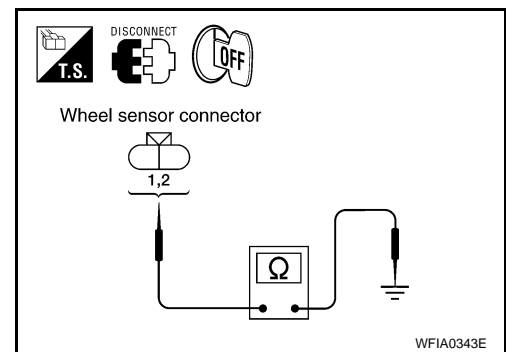

### 6.CHECK WIRING HARNESS FOR OPEN CIRCUIT

- Check continuity between ABS actuator and electric unit (control unit) harness connector E125 and the malfunctioning wheel sensor harness connector E18, E117, C10, or C11.

Wheel sensor	ABS actuator and electric unit (control unit)		Wheel sensor		Continuity
	Connector	Terminal	Connector	Terminal	
Front LH	E125	45	E18	1	Yes
		46		2	
Front RH		34	E117	1	
		33		2	
Rear LH		37	C11	2	
		36		1	
Rear RH		42	C10	2	
		43		1	

Is the inspection result normal?

YES >> Replace the ABS actuator and electric unit (control unit). Refer to [BRC-144, "Removal and Installation"](#).

NO >> Repair the circuit.

# C1101, C1102, C1103, C1104 WHEEL SENSOR-1

< COMPONENT DIAGNOSIS >

[ABLS/ABS]

## Component Inspection

INFOID:000000001601011

### 1. CHECK DATA MONITOR

On "DATA MONITOR", select "FR LH SENSOR", "FR RH SENSOR", "RR LH SENSOR", and "RR RH SENSOR", and check the vehicle speed.

Wheel sensor	Vehicle speed (DATA MONITOR)
FR LH SENSOR	Nearly matches the speedometer display ( $\pm 10\%$ or less)
FR RH SENSOR	
RR LH SENSOR	
RR RH SENSOR	

Is the inspection result normal?

YES >> INSPECTION END

NO >> Go to diagnosis procedure. Refer to [BRC-82, "Diagnosis Procedure"](#).

# C1105, C1106, C1107, C1108 WHEEL SENSOR-2

< COMPONENT DIAGNOSIS >

[ABLS/ABS]

## C1105, C1106, C1107, C1108 WHEEL SENSOR-2

### Description

INFOID:000000001601013

When the sensor rotor rotates, the magnetic field changes. It converts the magnetic field changes to current signals (rectangular wave) and transmits them to the ABS actuator and electric unit (control unit).

### DTC Logic

INFOID:000000001601014

### DTC DETECTION LOGIC

DTC	Display item	Malfunction detected condition	Possible cause
C1105	RR RH SENSOR-2	When the circuit in the rear RH wheel sensor is short-circuited. Or when the distance between the wheel sensor and sensor rotor is too large and the sensor pulse cannot be recognized by the control unit.	<ul style="list-style-type: none"><li>• Harness or connector</li><li>• Wheel sensor</li><li>• ABS actuator and electric unit (control unit)</li></ul>
C1106	RR LH SENSOR-2	When the circuit in the rear LH wheel sensor is short-circuited. Or when the distance between the wheel sensor and sensor rotor is too large and the sensor pulse cannot be recognized by the control unit.	
C1107	FR RH SENSOR-2	When the circuit in the front RH wheel sensor is short-circuited. Or when the distance between the wheel sensor and sensor rotor is too large and the sensor pulse cannot be recognized by the control unit.	
C1108	FR LH SENSOR-2	When the circuit in the front LH wheel sensor is short-circuited. Or when the distance between the wheel sensor and sensor rotor is too large and the sensor pulse cannot be recognized by the control unit.	

### DTC CONFIRMATION PROCEDURE

#### 1.CHECK SELF-DIAGNOSIS RESULTS

Check the self-diagnosis results.

Self-diagnosis results
RR RH SENSOR-2
RR LH SENSOR-2
FR RH SENSOR-2
FR LH SENSOR-2

Is above displayed on the self-diagnosis display?

- YES >> Proceed to diagnosis procedure. Refer to [BRC-85. "Diagnosis Procedure"](#).  
NO >> INSPECTION END

### Diagnosis Procedure

INFOID:000000001677599

#### **CAUTION:**

**Do not check between wheel sensor terminals.**

### INSPECTION PROCEDURE

#### 1.CONNECTOR INSPECTION

Disconnect the ABS actuator and electric unit (control unit) connector E125 and wheel sensor of malfunctioning code.

Check the terminals for deformation, disconnection, looseness or damage.

Is the inspection result normal?

- YES >> GO TO 2  
NO >> Repair or replace as necessary.

## C1105, C1106, C1107, C1108 WHEEL SENSOR-2

< COMPONENT DIAGNOSIS >

[ABLS/ABS]

### 2. CHECK WHEEL SENSOR OUTPUT SIGNAL

1. Connect ABS active wheel sensor tester (J-45741) to wheel sensor using appropriate adapter.
2. Turn on the ABS active wheel sensor tester power switch.

**NOTE:**

The green POWER indicator should illuminate. If the POWER indicator does not illuminate, replace the battery in the ABS active wheel sensor tester before proceeding.

3. Spin the wheel of the vehicle by hand and observe the red SENSOR indicator on the ABS active wheel sensor tester. The red SENSOR indicator should flash on and off to indicate an output signal.

**NOTE:**

If the red SENSOR indicator illuminates but does not flash, reverse the polarity of the tester leads and retest.

Does the ABS active wheel sensor tester detect a signal?

YES >> GO TO 3

NO >> Replace the wheel sensor. Refer to [BRC-142, "Removal and Installation"](#).

### 3. CHECK TIRES

Check for inflation pressure, wear and size of each tire.

Are tire pressure and size correct and is tire wear within specifications?

YES >> GO TO 4

NO >> Adjust tire pressure or replace tire(s).

### 4. CHECK WHEEL BEARINGS

Check wheel bearing axial end play. Refer to [FAX-5, "On-Vehicle Inspection and Service"](#) (front) or [RAX-5, "On-Vehicle Inspection"](#) (rear).

Is the inspection result normal?

YES >> GO TO 5

NO >> Repair or replace as necessary. Refer to [FAX-6, "Removal and Installation"](#) (front) or [RAX-7, "Removal and Installation"](#) (rear).

### 5. CHECK WIRING HARNESS FOR SHORT CIRCUIT

1. Disconnect ABS actuator and electric unit (control unit) connector and wheel sensor connector of malfunction code No.
2. Check continuity between wheel sensor harness connector terminals and ground.

**Continuity should not exist.**

Is the inspection result normal?

YES >> GO TO 6

NO >> Repair the circuit.

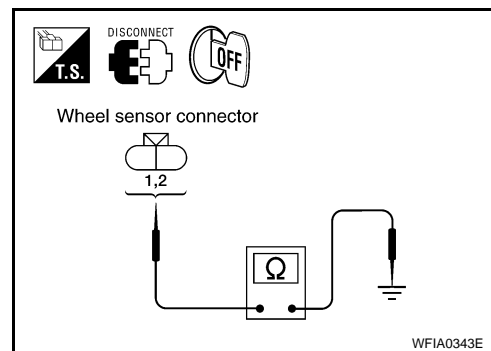

### 6. CHECK WIRING HARNESS FOR OPEN CIRCUIT

1. Check continuity between ABS actuator and electric unit (control unit) harness connector E125 and the malfunctioning wheel sensor harness connector E18, E117, C10, or C11.

# C1105, C1106, C1107, C1108 WHEEL SENSOR-2

< COMPONENT DIAGNOSIS >

[ABLS/ABS]

Wheel sensor	ABS actuator and electric unit (control unit)		Wheel sensor		Continuity
	Connector	Terminal	Connector	Terminal	
Front LH	E125	45	E18	1	Yes
		46		2	
Front RH		34	E117	1	
		33		2	
Rear LH		37	C11	2	
		36		1	
Rear RH		42	C10	2	
		43		1	

Is the inspection result normal?

YES >> Replace the ABS actuator and electric unit (control unit). Refer to [BRC-144, "Removal and Installation"](#).

NO >> Repair the circuit.

## Component Inspection

INFOID:000000001677600

### 1. CHECK DATA MONITOR

On "DATA MONITOR", select "FR LH SENSOR", "FR RH SENSOR", "RR LH SENSOR", and "RR RH SENSOR", and check the vehicle speed.

Wheel sensor	Vehicle speed (DATA MONITOR)
FR LH SENSOR	Nearly matches the speedometer display ( $\pm 10\%$ or less)
FR RH SENSOR	
RR LH SENSOR	
RR RH SENSOR	

Is the inspection result normal?

YES >> INSPECTION END

NO >> Go to diagnosis procedure. Refer to [BRC-85, "Diagnosis Procedure"](#).

# C1109 POWER AND GROUND SYSTEM

< COMPONENT DIAGNOSIS >

[ABLS/ABS]

## C1109 POWER AND GROUND SYSTEM

### Description

INFOID:000000001601018

Supplies electric power to the ABS actuator and electric unit (control unit).

### DTC Logic

INFOID:000000001601019

### DTC DETECTION LOGIC

DTC	Display item	Malfunction detected condition	Possible cause
C1109	BATTERY VOLTAGE [ABNORMAL]	When the ABS actuator and electric unit (control unit) power supply voltage is lower than normal.	<ul style="list-style-type: none"> <li>• Harness or connector</li> <li>• ABS actuator and electric unit (control unit)</li> </ul>

### DTC CONFIRMATION PROCEDURE

#### 1. CHECK SELF-DIAGNOSIS RESULTS

Check the self-diagnosis results.

Self-diagnosis results
BATTERY VOLTAGE [ABNORMAL]

Is above displayed on the self-diagnosis display?

- YES >> Proceed to diagnosis procedure. Refer to [BRC-88, "Diagnosis Procedure"](#).  
 NO >> INSPECTION END

### Diagnosis Procedure

INFOID:000000001601020

### INSPECTION PROCEDURE

#### 1. CHECK CONNECTOR

1. Turn ignition switch OFF.
2. Disconnect ABS actuator and electric unit (control unit) connector.
3. Check terminal for deformation, disconnection, looseness, and so on. If any malfunction is found, repair or replace terminal.
4. Reconnect connectors and then perform the self-diagnosis. Refer to [BRC-78, "CONSULT-III Function \(ABS\)"](#).

Is any item indicated on the self-diagnosis display?

- YES >> GO TO 2  
 NO >> Poor connection of connector terminal. Repair or replace connector.

#### 2. CHECK ABS ACTUATOR AND ELECTRIC UNIT (CONTROL UNIT) POWER SUPPLY CIRCUIT AND GROUND CIRCUIT

1. Turn ignition switch OFF.
2. Disconnect ABS actuator and electric unit (control unit) connector.
3. Turn ignition switch ON or OFF and check voltage between ABS actuator and electric unit (control unit) harness connector terminal and ground.

ABS actuator and electric unit (control unit)		—	Condition	Voltage
Connector	Terminal			
E125	4	Ground	Ignition switch: ON	Battery voltage
			Ignition switch: OFF	Approx. 0V

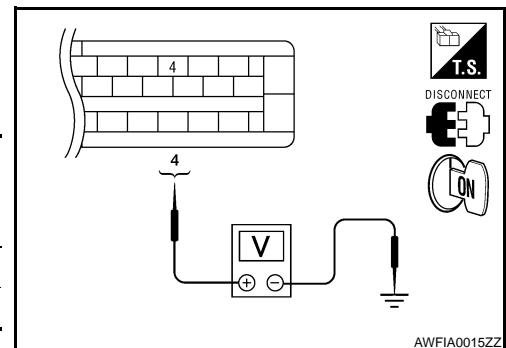

4. Turn ignition switch OFF.



# C1109 POWER AND GROUND SYSTEM

[ABLS/ABS]

## < COMPONENT DIAGNOSIS >

5. Check continuity between ABS actuator and electric unit (control unit) harness connector terminals and ground.

ABS actuator and electric unit (control unit)		—	Continuity
Connector	Terminal		
E125	16, 47	Ground	Yes

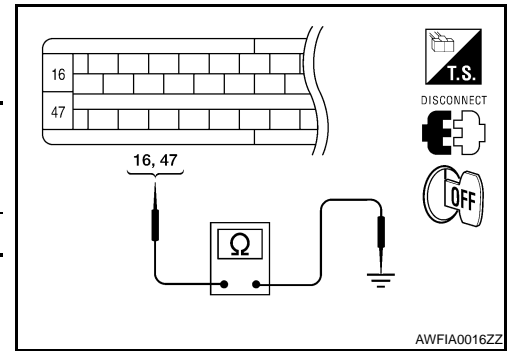

### Is the inspection result normal?

- YES >> Check battery for terminal looseness, low voltage, etc. If any malfunction is found, repair malfunctioning parts.
- NO >> Repair or replace malfunctioning components.

A  
B  
C  
D  
E  
G  
H  
I  
J  
K  
L  
M  
N  
O  
P

**BRC**

# C1110, C1113, C1160, C1170 ABS ACTUATOR AND ELECTRIC UNIT (CONTROL UNIT)

< COMPONENT DIAGNOSIS >

[ABLS/ABS]

## C1110, C1113, C1160, C1170 ABS ACTUATOR AND ELECTRIC UNIT (CONTROL UNIT)

### DTC Logic

INFOID:000000001601022

### DTC DETECTION LOGIC

DTC	Display item	Malfunction detected condition	Possible cause
C1110	CONTROLLER FAILURE	When there is an internal malfunction in the ABS actuator and electric unit (control unit).	• ABS actuator and electric unit (control unit)
C1113	G-SENSOR	G-sensor is malfunctioning.	
C1160	DECEL G SEN SET	G-sensor is malfunctioning.	
C1170	VARIANT CODING	In a case where VARIANT CODING is different.	

### DTC CONFIRMATION PROCEDURE

#### 1. CHECK SELF-DIAGNOSIS RESULTS

Check the self-diagnosis results.

Self-diagnosis results
CONTROLLER FAILURE
G-SENSOR
DECEL G SEN SET
VARIANT CODING

Is above displayed on the self-diagnosis display?

- YES >> Proceed to diagnosis procedure. Refer to [BRC-90, "Diagnosis Procedure"](#).  
NO >> INSPECTION END

### Diagnosis Procedure

INFOID:000000001601023

### INSPECTION PROCEDURE

#### 1. REPLACE ABS ACTUATOR AND ELECTRIC UNIT (CONTROL UNIT)

>> Replace ABS actuator and electric unit (control unit). Refer to [BRC-144, "Removal and Installation"](#).

# C1111 ABS MOTOR, MOTOR RELAY SYSTEM

< COMPONENT DIAGNOSIS >

[ABLS/ABS]

## C1111 ABS MOTOR, MOTOR RELAY SYSTEM

### Description

INFOID:000000001601025

#### PUMP

The pump returns the brake fluid stored in the reservoir to the master cylinder by reducing the pressure.

#### MOTOR

The motor drives the pump according to the signals transmitted by the ABS actuator and electric unit (control unit).

### DTC Logic

INFOID:000000001601026

### DTC DETECTION LOGIC

DTC	Display item	Malfunction detected condition	Possible cause
C1111	PUMP MOTOR	During the actuator motor operating with ON, when the actuator motor turns OFF, or when the control line for actuator motor relay is open.	<ul style="list-style-type: none"><li>• Harness or connector</li><li>• ABS actuator and electric unit (control unit)</li></ul>
		During the actuator motor operating with OFF, when the actuator motor turns ON, or when the control line for relay is shorted to ground.	

### DTC CONFIRMATION PROCEDURE

#### 1. CHECK SELF-DIAGNOSIS RESULTS

Check the self-diagnosis results.

Self-diagnosis results
PUMP MOTOR

Is above displayed on the self-diagnosis display?

- YES >> Proceed to diagnosis procedure. Refer to [BRC-91, "Diagnosis Procedure"](#).  
NO >> INSPECTION END

### Diagnosis Procedure

INFOID:000000001601027

### INSPECTION PROCEDURE

#### 1. CHECK CONNECTOR

1. Turn ignition switch OFF.
2. Disconnect ABS actuator and electric unit (control unit) connector.
3. Check terminal for deformation, disconnect, looseness, and so on. If any malfunction is found, repair or replace terminal.
4. Reconnect connectors and then perform the self-diagnosis. Refer to [BRC-78, "CONSULT-III Function \(ABS\)"](#).

Is any item indicated on the self-diagnosis display?

- YES >> GO TO 2  
NO >> Poor connection of connector terminal. Repair or replace connector.

#### 2. CHECK ABS MOTOR AND MOTOR RELAY POWER SUPPLY CIRCUIT

# C1111 ABS MOTOR, MOTOR RELAY SYSTEM

[ABLS/ABS]

## < COMPONENT DIAGNOSIS >

1. Turn ignition switch OFF.
2. Disconnect ABS actuator and electric unit (control unit) connector.
3. Check voltage between the ABS actuator and electric unit (control unit) harness connector terminal and ground.

ABS actuator and electric unit (control unit)		—	Voltage
Connector	Terminal		
E125	1	Ground	Battery voltage

Is the inspection result normal?

- YES >> GO TO 3  
 NO >> Repair or replace malfunctioning components.

### 3.CHECK ABS ACTUATOR AND ELECTRIC UNIT (CONTROL UNIT) GROUND CIRCUIT

Check continuity between ABS actuator and electric unit (control unit) harness connector terminals and ground.

ABS actuator and electric unit (control unit)		—	Continuity
Connector	Terminal		
E125	16, 47	Ground	Yes

Is the inspection result normal?

- YES >> Replace ABS actuator and electric unit (control unit).  
 Refer to [BRC-144, "Removal and Installation"](#).  
 NO >> Repair or replace malfunctioning components.

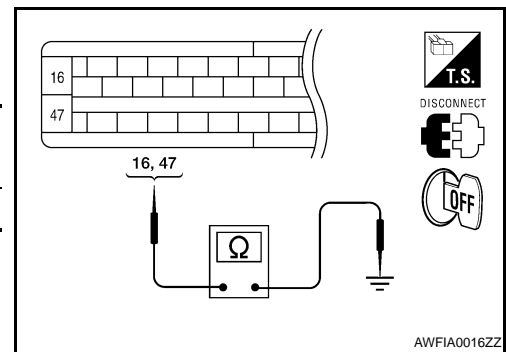
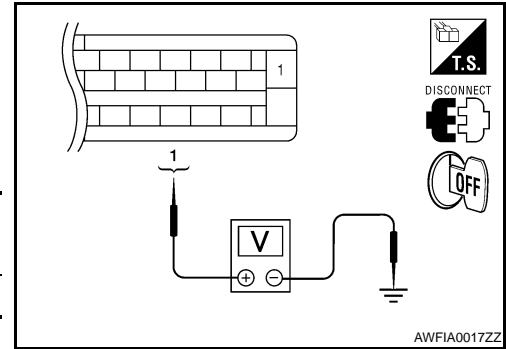

## Component Inspection

INFOID:000000001601028

### 1.CHECK ACTIVE TEST

1. On "ACTIVE TEST", select "ABS MOTOR".
2. Touch ON and OFF on screen. Make sure motor relay and actuator relay operates as shown in table below.

Operation	ON	OFF
MOTOR RELAY	ON	OFF
ACTUATOR RLY	ON	ON

Is the inspection result normal?

- YES >> INSPECTION END  
 NO >> Go to diagnosis procedure. Refer to [BRC-91, "Diagnosis Procedure"](#).

# C1115 WHEEL SENSOR

[ABLS/ABS]

< COMPONENT DIAGNOSIS >

## C1115 WHEEL SENSOR

### Description

INFOID:000000001601035

When the sensor rotor rotates, the magnetic field changes. It converts the magnetic field changes to current signals (rectangular wave) and transmits them to the ABS actuator and electric unit (control unit).

### DTC Logic

INFOID:000000001601036

### DTC DETECTION LOGIC

DTC	Display item	Malfunction detected condition	Possible cause
C1115	ABS SENSOR [ABNORMAL SIGNAL]	When wheel sensor input signal is malfunctioning.	<ul style="list-style-type: none"><li>• Harness or connector</li><li>• Wheel sensor</li><li>• ABS actuator and electric unit (control unit)</li></ul>

### DTC CONFIRMATION PROCEDURE

#### 1. CHECK SELF-DIAGNOSIS RESULTS

Check the self-diagnosis results.

Self-diagnosis results
ABS SENSOR [ABNORMAL SIGNAL]

Is above displayed on the self-diagnosis display?

- YES >> Proceed to diagnosis procedure. Refer to [BRC-93, "Diagnosis Procedure"](#).  
NO >> INSPECTION END

### Diagnosis Procedure

INFOID:000000001677601

#### **CAUTION:**

**Do not check between wheel sensor terminals.**

### INSPECTION PROCEDURE

#### 1. CONNECTOR INSPECTION

Disconnect the ABS actuator and electric unit (control unit) connector E125 and wheel sensor of malfunctioning code.

Check the terminals for deformation, disconnection, looseness or damage.

Is the inspection result normal?

- YES >> GO TO 2  
NO >> Repair or replace as necessary.

#### 2. CHECK WHEEL SENSOR OUTPUT SIGNAL

1. Connect ABS active wheel sensor tester (J-45741) to wheel sensor using appropriate adapter.
2. Turn on the ABS active wheel sensor tester power switch.

##### **NOTE:**

The green POWER indicator should illuminate. If the POWER indicator does not illuminate, replace the battery in the ABS active wheel sensor tester before proceeding.

3. Spin the wheel of the vehicle by hand and observe the red SENSOR indicator on the ABS active wheel sensor tester. The red SENSOR indicator should flash on and off to indicate an output signal.

##### **NOTE:**

If the red SENSOR indicator illuminates but does not flash, reverse the polarity of the tester leads and retest.

Does the ABS active wheel sensor tester detect a signal?

- YES >> GO TO 3  
NO >> Replace the wheel sensor. Refer to [BRC-142, "Removal and Installation"](#).

#### 3. CHECK TIRES

# C1115 WHEEL SENSOR

[ABLS/ABS]

## < COMPONENT DIAGNOSIS >

Check for inflation pressure, wear and size of each tire.

Are tire pressure and size correct and is tire wear within specifications?

- YES >> GO TO 4
- NO >> Adjust tire pressure or replace tire(s).

### 4.CHECK WHEEL BEARINGS

Check wheel bearing axial end play. Refer to [FAX-5, "On-Vehicle Inspection and Service"](#) (front) or [RAX-5, "On-Vehicle Inspection"](#) (rear).

Is the inspection result normal?

- YES >> GO TO 5
- NO >> Repair or replace as necessary. Refer to [FAX-6, "Removal and Installation"](#) (front) or [RAX-7, "Removal and Installation"](#) (rear).

### 5.CHECK WIRING HARNESS FOR SHORT CIRCUIT

1. Disconnect ABS actuator and electric unit (control unit) connector and wheel sensor connector of malfunction code No.
2. Check continuity between wheel sensor harness connector terminals and ground.

**Continuity should not exist.**

Is the inspection result normal?

- YES >> GO TO 6
- NO >> Repair the circuit.

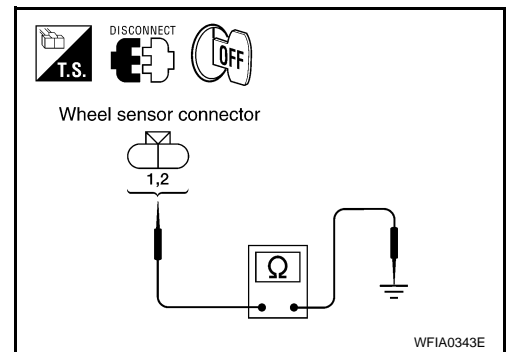

### 6.CHECK WIRING HARNESS FOR OPEN CIRCUIT

1. Check continuity between ABS actuator and electric unit (control unit) harness connector E125 and the malfunctioning wheel sensor harness connector E18, E117, C10, or C11.

Wheel sensor	ABS actuator and electric unit (control unit)		Wheel sensor		Continuity
	Connector	Terminal	Connector	Terminal	
Front LH	E125	45	E18	1	Yes
		46		2	
Front RH		34	E117	1	
		33		2	
Rear LH		37	C11	2	
		36		1	
Rear RH		42	C10	2	
		43		1	

Is the inspection result normal?

- YES >> Replace the ABS actuator and electric unit (control unit). Refer to [BRC-144, "Removal and Installation"](#).
- NO >> Repair the circuit.

## Component Inspection

INFOID:000000001677602

### 1.CHECK DATA MONITOR

On "DATA MONITOR", select "FR LH SENSOR", "FR RH SENSOR", "RR LH SENSOR", and "RR RH SENSOR", and check the vehicle speed.

Wheel sensor	Vehicle speed (DATA MONITOR)
--------------	------------------------------

# C1115 WHEEL SENSOR

[ABLS/ABS]

< COMPONENT DIAGNOSIS >

FR LH SENSOR	Nearly matches the speedometer display ( $\pm 10\%$ or less)	A
FR RH SENSOR		
RR LH SENSOR		
RR RH SENSOR		B

Is the inspection result normal?

YES >> INSPECTION END

NO >> Go to diagnosis procedure. Refer to [BRC-93. "Diagnosis Procedure"](#).

C

D

E

**BRC**

G

H

I

J

K

L

M

N

O

P

# C1116 STOP LAMP SWITCH

[ABLS/ABS]

< COMPONENT DIAGNOSIS >

## C1116 STOP LAMP SWITCH

### Description

INFOID:000000001601040

The stop lamp switch transmits the stop lamp switch signal (ON/OFF) to the ABS actuator and electric unit (control unit).

### DTC Logic

INFOID:000000001601041

### DTC DETECTION LOGIC

DTC	Display item	Malfunction detected condition	Possible cause
C1116	STOP LAMP SW	When stop lamp switch circuit is open.	<ul style="list-style-type: none"><li>• Harness or connector</li><li>• Stop lamp switch</li><li>• ABS actuator and electric unit (control unit)</li></ul>

### DTC CONFIRMATION PROCEDURE

#### 1. CHECK SELF-DIAGNOSIS RESULTS

Check the self-diagnosis results.

Self-diagnosis results
STOP LAMP SW

Is above displayed on the self-diagnosis display?

- YES >> Proceed to diagnosis procedure. Refer to [BRC-96. "Diagnosis Procedure"](#).  
NO >> INSPECTION END

### Diagnosis Procedure

INFOID:000000001601042

### INSPECTION PROCEDURE

#### 1. CONNECTOR INSPECTION

1. Disconnect the ABS actuator and electric unit (control unit) connector E125 and stop lamp switch connector E38.
2. Check the terminals for deformation, disconnection, looseness or damage.

Is the inspection result normal?

- YES >> GO TO 2  
NO >> Repair or replace as necessary.

#### 2. STOP LAMP SWITCH INSPECTION

Check the voltage between the ABS actuator and electric unit (control unit) harness connector E125 terminal 41 and body ground.

**Brake pedal depressed : Battery voltage (approx. 12V)**

**Brake pedal not depressed : Approx. 0V**

Is the inspection result normal?

- YES >> Perform self-diagnosis again. If the same results appear, replace ABS actuator and electric unit (control unit). Refer to [BRC-144. "Removal and Installation"](#).  
NO >> Refer to [EXL-3. "Work Flow"](#).

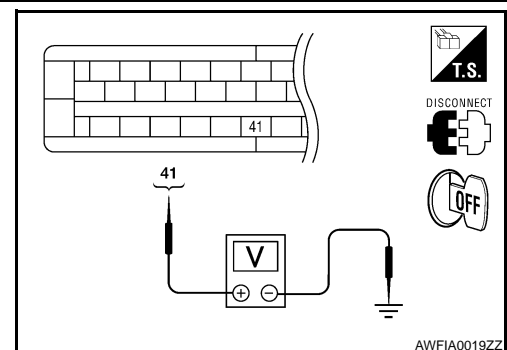



# C1120, C1122, C1124, C1126 IN ABS SOL

< COMPONENT DIAGNOSIS >

[ABLS/ABS]

## C1120, C1122, C1124, C1126 IN ABS SOL

### Description

INFOID:000000001601044

The solenoid valve increases, holds or decreases the fluid pressure of each brake caliper according to the signals transmitted by the ABS actuator and electric unit (control unit).

### DTC Logic

INFOID:000000001601045

### DTC DETECTION LOGIC

DTC	Display item	Malfunction detected condition	Possible cause
C1120	FR LH IN ABS SOL	When the control unit detects a malfunction in the front LH inlet solenoid circuit.	• ABS actuator and electric unit (control unit)
C1122	FR RH IN ABS SOL	When the control unit detects a malfunction in the front RH inlet solenoid circuit.	
C1124	RR LH IN ABS SOL	When the control unit detects a malfunction in the rear LH inlet solenoid circuit.	
C1126	RR RH IN ABS SOL	When the control unit detects a malfunction in the rear RH inlet solenoid circuit.	

### DTC CONFIRMATION PROCEDURE

#### 1.CHECK SELF-DIAGNOSIS RESULTS

Check the self-diagnosis results.

Self-diagnosis results
FR LH IN ABS SOL
FR RH IN ABS SOL
RR LH IN ABS SOL
RR RH IN ABS SOL

Is above displayed on the self-diagnosis display?

- YES >> Proceed to diagnosis procedure. Refer to [BRC-97. "Diagnosis Procedure"](#).  
NO >> INSPECTION END

### Diagnosis Procedure

INFOID:000000001601046

### INSPECTION PROCEDURE

#### 1.CHECK CONNECTOR

1. Turn ignition switch OFF.
2. Disconnect ABS actuator and electric unit (control unit) connector.
3. Check terminal for deformation, disconnection, looseness, and so on. If any malfunction is found, repair or replace terminal.
4. Reconnect connectors and then perform the self-diagnosis. Refer to [BRC-78. "CONSULT-III Function \(ABS\)"](#).

Is any item indicated on the self-diagnosis display?

- YES >> GO TO 2  
NO >> Poor connection of connector terminal. Repair or replace connector.

#### 2.CHECK SOLENOID, SWITCH-OVER VALVE AND ACTUATOR RELAY POWER SUPPLY CIRCUIT

# C1120, C1122, C1124, C1126 IN ABS SOL

[ABLS/ABS]

## < COMPONENT DIAGNOSIS >

1. Turn ignition switch OFF.
2. Disconnect ABS actuator and electric unit (control unit) connector.
3. Check voltage between ABS actuator and electric unit (control unit) harness connector terminal and ground.

ABS actuator and electric unit (control unit)		—	Voltage
Connector	Terminal		
E125	32	Ground	Battery voltage

Is the inspection result normal?

- YES >> GO TO 3  
 NO >> Repair or replace malfunctioning components.

### 3.CHECK SOLENOID, SWITCH-OVER VALVE AND ACUATOR RELAY GROUND CIRCUIT

Check continuity between ABS actuator and electric unit (control unit) harness connector terminals and ground.

ABS actuator and electric unit (control unit)		—	Continuity
Connector	Terminal		
E125	16, 47	Ground	Yes

Is the inspection result normal?

- YES >> Replace ABS actuator and electric unit (control unit).  
 Refer to [BRC-144, "Removal and Installation"](#).  
 NO >> Repair or replace malfunctioning components.

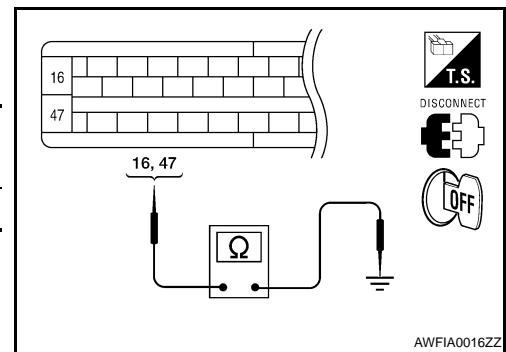
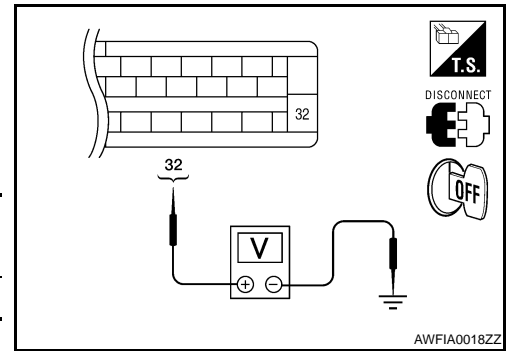

## Component Inspection

INFOID:000000001601047

### 1.CHECK ACTIVE TEST

1. Select each test menu item on "ACTIVE TEST".
2. On the display, touch "UP", "KEEP", and "DOWN", and check that the system operates as shown in the table below.

Operation		ABS solenoid valve			ABS solenoid valve (ACT)		
		UP	KEEP	DOWN	UP	ACTUA-TOR UP	ACTUA-TOR KEEP
FR RH SOL FR RH ABS SOLE- NOID (ACT)	FR RH IN SOL	OFF	ON	ON	OFF	OFF	OFF
	FR RH OUT SOL	OFF	OFF	ON*	OFF	OFF	OFF
FR LH SOL FR LH ABS SOLE- NOID (ACT)	FR LH IN SOL	OFF	ON	ON	OFF	OFF	OFF
	FR LH OUT SOL	OFF	OFF	ON*	OFF	OFF	OFF
RR RH SOL RR RH ABS SOLE- NOID (ACT)	RR RH IN SOL	OFF	ON	ON	OFF	OFF	OFF
	RR RH OUT SOL	OFF	OFF	ON*	OFF	OFF	OFF
RR LH SOL RR LH ABS SOLE- NOID (ACT)	RR LH IN SOL	OFF	ON	ON	OFF	OFF	OFF
	RR LH OUT SOL	OFF	OFF	ON*	OFF	OFF	OFF
REAR SOL	RR RH IN SOL	OFF	ON	ON	OFF	OFF	OFF
	RR RH OUT SOL	OFF	OFF	ON*	OFF	OFF	OFF
	RR LH IN SOL	OFF	ON	ON	OFF	OFF	OFF
	RR LH OUT SOL	OFF	OFF	ON*	OFF	OFF	OFF

\*: ON for 1 to 2 seconds after the touch, and then OFF

Is the inspection result normal?

- YES >> INSPECTION END

# C1120, C1122, C1124, C1126 IN ABS SOL

< COMPONENT DIAGNOSIS >

[ABLS/ABS]

NO >> Go to diagnosis procedure. Refer to [BRC-97. "Diagnosis Procedure"](#).

A

B

C

D

E

**BRC**

G

H

I

J

K

L

M

N

O

P

# C1121, C1123, C1125, C1127 OUT ABS SOL

< COMPONENT DIAGNOSIS >

[ABLS/ABS]

## C1121, C1123, C1125, C1127 OUT ABS SOL

### Description

INFOID:000000001601049

The solenoid valve increases, holds or decreases the fluid pressure of each brake caliper according to the signals transmitted by the ABS actuator and electric unit (control unit).

### DTC Logic

INFOID:000000001601050

### DTC DETECTION LOGIC

DTC	Display item	Malfunction detected condition	Possible cause
C1121	FR LH OUT ABS SOL	When the control unit detects a malfunction in the front LH outlet solenoid circuit.	• ABS actuator and electric unit (control unit)
C1123	FR RH OUT ABS SOL	When the control unit detects a malfunction in the front RH outlet solenoid circuit.	
C1125	RR LH OUT ABS SOL	When the control unit detects a malfunction in the rear LH outlet solenoid circuit.	
C1127	RR RH OUT ABS SOL	When the control unit detects a malfunction in the rear RH outlet solenoid circuit.	

### DTC CONFIRMATION PROCEDURE

#### 1. CHECK SELF-DIAGNOSIS RESULTS

Check the self-diagnosis results.

Self-diagnosis results
FR LH OUT ABS SOL
FR RH OUT ABS SOL
RR LH OUT ABS SOL
RR RH OUT ABS SOL

Is above displayed on the self-diagnosis display?

- YES >> Proceed to diagnosis procedure. Refer to [BRC-100. "Diagnosis Procedure"](#).  
NO >> INSPECTION END

### Diagnosis Procedure

INFOID:000000001677603

### INSPECTION PROCEDURE

#### 1. CHECK CONNECTOR

1. Turn ignition switch OFF.
2. Disconnect ABS actuator and electric unit (control unit) connector.
3. Check terminal for deformation, disconnection, looseness, and so on. If any malfunction is found, repair or replace terminal.
4. Reconnect connectors and then perform the self-diagnosis. Refer to [BRC-78. "CONSULT-III Function \(ABS\)"](#).

Is any item indicated on the self-diagnosis display?

- YES >> GO TO 2  
NO >> Poor connection of connector terminal. Repair or replace connector.

#### 2. CHECK SOLENOID, SWITCH-OVER VALVE AND ACTUATOR RELAY POWER SUPPLY CIRCUIT

# C1121, C1123, C1125, C1127 OUT ABS SOL

[ABLS/ABS]

## < COMPONENT DIAGNOSIS >

1. Turn ignition switch OFF.
2. Disconnect ABS actuator and electric unit (control unit) connector.
3. Check voltage between ABS actuator and electric unit (control unit) harness connector terminal and ground.

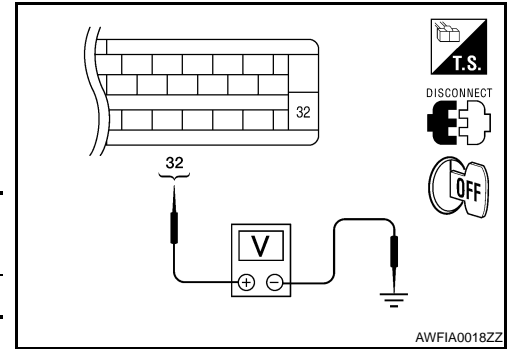

ABS actuator and electric unit (control unit)		—	Voltage
Connector	Terminal		
E125	32	Ground	Battery voltage

Is the inspection result normal?

- YES >> GO TO 3  
 NO >> Repair or replace malfunctioning components.

### 3.CHECK SOLENOID, SWITCH-OVER VALVE AND ACUATOR RELAY GROUND CIRCUIT

Check continuity between ABS actuator and electric unit (control unit) harness connector terminals and ground.

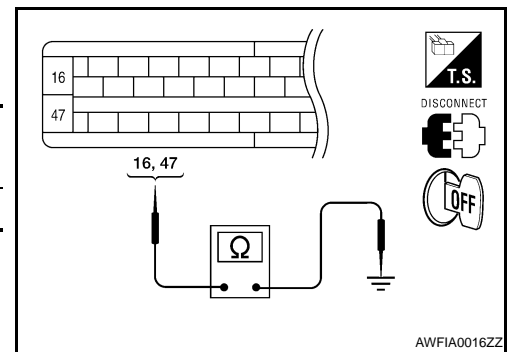

ABS actuator and electric unit (control unit)		—	Continuity
Connector	Terminal		
E125	16, 47	Ground	Yes

Is the inspection result normal?

- YES >> Replace ABS actuator and electric unit (control unit).  
 Refer to [BRC-144, "Removal and Installation"](#).  
 NO >> Repair or replace malfunctioning components.

## Component Inspection

INFOID:000000001677604

### 1.CHECK ACTIVE TEST

1. Select each test menu item on "ACTIVE TEST".
2. On the display, touch "UP", "KEEP", and "DOWN", and check that the system operates as shown in the table below.

Operation		ABS solenoid valve			ABS solenoid valve (ACT)		
		UP	KEEP	DOWN	UP	ACTUA-TOR UP	ACTUA-TOR KEEP
FR RH SOL FR RH ABS SOLE- NOID (ACT)	FR RH IN SOL	OFF	ON	ON	OFF	OFF	OFF
	FR RH OUT SOL	OFF	OFF	ON*	OFF	OFF	OFF
FR LH SOL FR LH ABS SOLE- NOID (ACT)	FR LH IN SOL	OFF	ON	ON	OFF	OFF	OFF
	FR LH OUT SOL	OFF	OFF	ON*	OFF	OFF	OFF
RR RH SOL RR RH ABS SOLE- NOID (ACT)	RR RH IN SOL	OFF	ON	ON	OFF	OFF	OFF
	RR RH OUT SOL	OFF	OFF	ON*	OFF	OFF	OFF
RR LH SOL RR LH ABS SOLE- NOID (ACT)	RR LH IN SOL	OFF	ON	ON	OFF	OFF	OFF
	RR LH OUT SOL	OFF	OFF	ON*	OFF	OFF	OFF
REAR SOL	RR RH IN SOL	OFF	ON	ON	OFF	OFF	OFF
	RR RH OUT SOL	OFF	OFF	ON*	OFF	OFF	OFF
	RR LH IN SOL	OFF	ON	ON	OFF	OFF	OFF
	RR LH OUT SOL	OFF	OFF	ON*	OFF	OFF	OFF

\*: ON for 1 to 2 seconds after the touch, and then OFF

Is the inspection result normal?

- YES >> INSPECTION END

## C1121, C1123, C1125, C1127 OUT ABS SOL

< COMPONENT DIAGNOSIS >

[ABLS/ABS]

---

NO >> Go to diagnosis procedure. Refer to [BRC-100. "Diagnosis Procedure"](#).

# C1130, C1131, C1136 ENGINE SIGNAL

< COMPONENT DIAGNOSIS >

[ABLS/ABS]

## C1130, C1131, C1136 ENGINE SIGNAL

### Description

INFOID:000000001601054

ABS actuator and electric unit (control unit) and ECM exchange the engine signal with CAN communication line.

### DTC Logic

INFOID:000000001601055

### DTC DETECTION LOGIC

DTC	Display item	Malfunction detected condition	Possible cause
C1130	ENGINE SIGNAL 1	Based on the signal from ECM, ABS actuator and electric unit (control unit) judges that engine fuel cut system is malfunctioning.	<ul style="list-style-type: none"><li>• Harness or connector</li><li>• ABS actuator and electric unit (control unit)</li><li>• ECM</li><li>• CAN communication line</li></ul>
C1131	ENGINE SIGNAL 2		
C1136	ENGINE SIGNAL 6		

### DTC CONFIRMATION PROCEDURE

#### 1. CHECK SELF-DIAGNOSIS RESULTS

Check the self-diagnosis results.

Self-diagnosis results
ENGINE SIGNAL 1
ENGINE SIGNAL 2
ENGINE SIGNAL 6

Is above displayed on the self-diagnosis display?

- YES >> Proceed to diagnosis procedure. Refer to [BRC-103, "Diagnosis Procedure"](#).  
NO >> INSPECTION END

### Diagnosis Procedure

INFOID:000000001601056

### INSPECTION PROCEDURE

#### 1. CHECK ENGINE SYSTEM

1. Perform ECM self-diagnosis. Repair or replace items indicated, then perform ECM self-diagnosis again. Refer to [EC-67, "CONSULT-III Function \(ENGINE\)"](#).
2. Perform ABS actuator and electric unit (control unit) self-diagnosis. Refer to [BRC-78, "CONSULT-III Function \(ABS\)"](#).

Is any item indicated on the self-diagnosis display?

- YES >> Repair or replace the affected part.  
NO >> INSPECTION END

# C1140 ACTUATOR RLY

< COMPONENT DIAGNOSIS >

[ABLS/ABS]

## C1140 ACTUATOR RLY

### Description

INFOID:000000001601058

Activates or deactivates each solenoid valve according to the signals transmitted by the ABS actuator and electric unit (control unit).

### DTC Logic

INFOID:000000001601059

### DTC DETECTION LOGIC

DTC	Display item	Malfunction detected condition	Possible cause
C1140	ACTUATOR RLY	ABS actuator relay or circuit malfunction.	<ul style="list-style-type: none"> <li>• Harness or connector</li> <li>• ABS actuator and electric unit (control unit)</li> </ul>

### DTC CONFIRMATION PROCEDURE

#### 1. CHECK SELF-DIAGNOSIS RESULTS

Check the self-diagnosis results.

Self-diagnosis results
ACTUATOR RLY

Is above displayed on the self-diagnosis display?

- YES >> Proceed to diagnosis procedure. Refer to [BRC-104. "Diagnosis Procedure"](#).  
 NO >> INSPECTION END

### Diagnosis Procedure

INFOID:000000001677605

### INSPECTION PROCEDURE

#### 1. CHECK CONNECTOR

1. Turn ignition switch OFF.
2. Disconnect ABS actuator and electric unit (control unit) connector.
3. Check terminal for deformation, disconnection, looseness, and so on. If any malfunction is found, repair or replace terminal.
4. Reconnect connectors and then perform the self-diagnosis. Refer to [BRC-78. "CONSULT-III Function \(ABS\)"](#).

Is any item indicated on the self-diagnosis display?

- YES >> GO TO 2  
 NO >> Poor connection of connector terminal. Repair or replace connector.

#### 2. CHECK SOLENOID, SWITCH-OVER VALVE AND ACTUATOR RELAY POWER SUPPLY CIRCUIT

1. Turn ignition switch OFF.
2. Disconnect ABS actuator and electric unit (control unit) connector.
3. Check voltage between ABS actuator and electric unit (control unit) harness connector terminal and ground.

ABS actuator and electric unit (control unit)		—	Voltage
Connector	Terminal		
E125	32	Ground	Battery voltage

Is the inspection result normal?

- YES >> GO TO 3  
 NO >> Repair or replace malfunctioning components.

#### 3. CHECK SOLENOID, SWITCH-OVER VALVE AND ACUATOR RELAY GROUND CIRCUIT

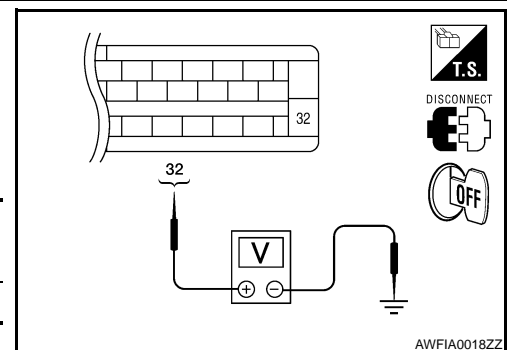

AWFIA0018ZZ



# C1140 ACTUATOR RLY

[ABLS/ABS]

## < COMPONENT DIAGNOSIS >

Check continuity between ABS actuator and electric unit (control unit) harness connector terminals and ground.

ABS actuator and electric unit (control unit)		—	Continuity
Connector	Terminal		
E125	16, 47	Ground	Yes

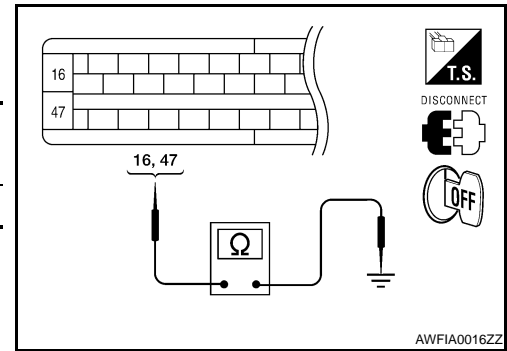

### Is the inspection result normal?

- YES >> Replace ABS actuator and electric unit (control unit). Refer to [BRC-144, "Removal and Installation"](#).
- NO >> Repair or replace malfunctioning components.

## Component Inspection

INFOID:000000001677606

### 1. CHECK ACTIVE TEST

- Select each test menu item on "ACTIVE TEST".
- On the display, touch "UP", "KEEP", and "DOWN", and check that the system operates as shown in the table below.

Operation		ABS solenoid valve			ABS solenoid valve (ACT)		
		UP	KEEP	DOWN	UP	ACTUA-TOR UP	ACTUA-TOR KEEP
FR RH SOL FR RH ABS SOLE- NOID (ACT)	FR RH IN SOL	OFF	ON	ON	OFF	OFF	OFF
	FR RH OUT SOL	OFF	OFF	ON*	OFF	OFF	OFF
FR LH SOL FR LH ABS SOLE- NOID (ACT)	FR LH IN SOL	OFF	ON	ON	OFF	OFF	OFF
	FR LH OUT SOL	OFF	OFF	ON*	OFF	OFF	OFF
RR RH SOL RR RH ABS SOLE- NOID (ACT)	RR RH IN SOL	OFF	ON	ON	OFF	OFF	OFF
	RR RH OUT SOL	OFF	OFF	ON*	OFF	OFF	OFF
RR LH SOL RR LH ABS SOLE- NOID (ACT)	RR LH IN SOL	OFF	ON	ON	OFF	OFF	OFF
	RR LH OUT SOL	OFF	OFF	ON*	OFF	OFF	OFF
REAR SOL	RR RH IN SOL	OFF	ON	ON	OFF	OFF	OFF
	RR RH OUT SOL	OFF	OFF	ON*	OFF	OFF	OFF
	RR LH IN SOL	OFF	ON	ON	OFF	OFF	OFF
	RR LH OUT SOL	OFF	OFF	ON*	OFF	OFF	OFF

\*: ON for 1 to 2 seconds after the touch, and then OFF

### Is the inspection result normal?

- YES >> INSPECTION END
- NO >> Go to diagnosis procedure. Refer to [BRC-104, "Diagnosis Procedure"](#).

# C1142 PRESS SENSOR

< COMPONENT DIAGNOSIS >

[ABLS/ABS]

## C1142 PRESS SENSOR

### Description

INFOID:000000001601063

The front and rear pressure sensors convert the brake fluid pressure to an electric signal and transmit it to the ABS actuator and electric unit (control unit).

### DTC Logic

INFOID:000000001601064

#### DTC DETECTION LOGIC

DTC	Display item	Malfunction detected condition	Possible cause
C1142	PRESS SEN CIRCUIT	Pressure sensor signal line is open or shorted, or pressure sensor is malfunctioning.	<ul style="list-style-type: none"> <li>• Harness or connector</li> <li>• Pressure sensor</li> <li>• ABS actuator and electric unit (control unit)</li> </ul>

#### DTC CONFIRMATION PROCEDURE

##### 1. CHECK SELF-DIAGNOSIS RESULTS

Check the self-diagnosis results.

Self-diagnosis results
PRESS SEN CIRCUIT

Is above displayed on the self-diagnosis display?

- YES >> Proceed to diagnosis procedure. Refer to [BRC-106. "Diagnosis Procedure"](#).  
 NO >> INSPECTION END

### Diagnosis Procedure

INFOID:000000001601065

#### FRONT PRESSURE SENSOR INSPECTION PROCEDURE

##### 1. CONNECTOR INSPECTION

1. Turn the ignition switch OFF.
2. Disconnect the front pressure sensor connector E31 and ABS actuator and electric unit (control unit) connector E125 and inspect the terminals for deformation, disconnection, looseness, or damage.

Is the inspection result normal?

- YES >> GO TO 2  
 NO >> Repair connector.

##### 2. FRONT PRESSURE SENSOR CIRCUIT INSPECTION

1. Measure the continuity between the ABS actuator and electric unit (control unit) harness connector E125 (A) and front pressure sensor harness connector E31 (B).

ABS actuator and electric unit (control unit)		Front pressure sensor		Continuity
Connector	Terminal	Connector	Terminal	
A: E125	18	B: E31	3	Yes
	19		1	
	20		2	

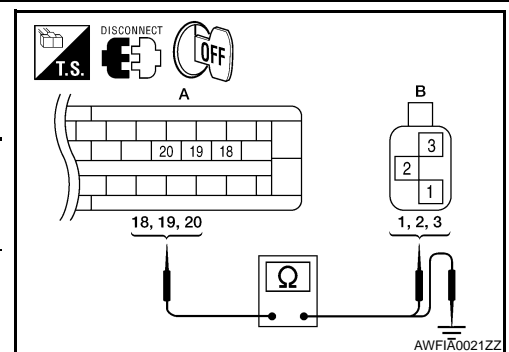

2. Measure the continuity between the ABS actuator and electric unit (control unit) harness connector E125 (A) and body ground.

# C1142 PRESS SENSOR

< COMPONENT DIAGNOSIS >

[ABLS/ABS]

ABS actuator and electric unit (control unit)		—	Continuity
Connector	Terminal		
A: E125	18	Ground	No
	19		
	20		

Is the inspection result normal?

YES >> GO TO 3

NO >> Repair or replace harness or connector.

## 3.FRONT PRESSURE SENSOR INSPECTION

1. Reconnect the front pressure sensor and ABS actuator and electric unit (control unit) connectors.
2. Use "DATA MONITOR" to check if the status of "PRESS SENSOR" is normal.

Condition	PRESS SENSOR (DATA MONITOR)
With ignition switch turned ON and brake pedal released.	Approx. 0 bar
With ignition switch turned ON and brake pedal depressed.	Positive value

Is the inspection result normal?

YES >> Inspection End.

NO >> Replace the front pressure sensor.

## REAR PRESSURE SENSOR INSPECTION PROCEDURE

### 1.CONNECTOR INSPECTION

1. Turn the ignition switch OFF.
2. Disconnect the rear pressure sensor connector E32 and ABS actuator and electric unit (control unit) connector E125 and inspect the terminals for deformation, disconnection, looseness, or damage.

Is the inspection result normal?

YES >> GO TO 2

NO >> Repair connector.

### 2.REAR PRESSURE SENSOR CIRCUIT INSPECTION

1. Measure the continuity between the ABS actuator and electric unit (control unit) harness connector E125 (A) and rear pressure sensor harness connector E32 (B).

ABS actuator and electric unit (control unit)		Rear pressure sensor		Continuity
Connector	Terminal	Connector	Terminal	
A: E125	21	B: E32	1	Yes
	22		3	
	23		2	

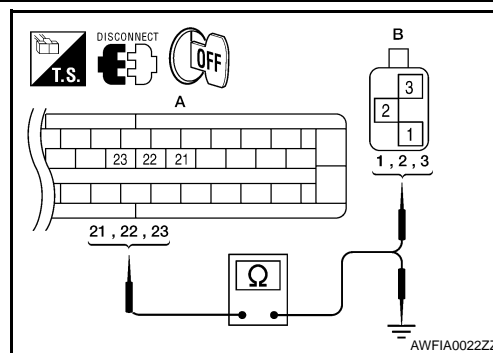

2. Measure the continuity between the ABS actuator and electric unit (control unit) harness connector E125 (A) and body ground.

ABS actuator and electric unit (control unit)		—	Continuity
Connector	Terminal		
A: E125	21	Ground	No
	22		
	23		

# C1142 PRESS SENSOR

[ABLS/ABS]

< COMPONENT DIAGNOSIS >

Is the inspection result normal?

- YES >> GO TO 3
- NO >> Repair or replace harness or connector.

## 3. REAR PRESSURE SENSOR INSPECTION

1. Reconnect the rear pressure sensor and ABS actuator and electric unit (control unit) connectors.
2. Use "DATA MONITOR" to check if the status of "PRESS SEN2" is normal.

Condition	PRESS SEN2 (DATA MONITOR)
With ignition switch turned ON and brake pedal released.	Approx. 0 bar
With ignition switch turned ON and brake pedal depressed.	Positive value

Is the inspection result normal?

- YES >> Inspection End.
- NO >> Replace the rear pressure sensor.

## Component Inspection

INFOID:000000001601066

### 1. CHECK DATA MONITOR

On "DATA MONITOR", select "PRESS SENSOR" and "PRESS SEN2" and check the brake fluid pressure.

Condition	PRESS SENSOR and PRESS SEN2 (DATA MONITOR)
With ignition switch turned ON and brake pedal released.	Approx. 0 bar
With ignition switch turned ON and brake pedal depressed.	Positive value

Is the inspection result normal?

- YES >> INSPECTION END
- NO >> Go to diagnosis procedure. Refer to [BRC-106, "Diagnosis Procedure"](#).

# C1155 BRAKE FLUID LEVEL SWITCH

< COMPONENT DIAGNOSIS >

[ABLS/ABS]

## C1155 BRAKE FLUID LEVEL SWITCH

### Description

INFOID:000000001601073

The brake fluid level switch converts the brake fluid level to an electric signal and transmits it to the ABS actuator and electric unit (control unit).

### DTC Logic

INFOID:000000001601074

#### DTC DETECTION LOGIC

DTC	Display item	Malfunction detected condition	Possible cause
C1155	BR FLUID LEVEL LOW	Brake fluid level is low or communication line between the ABS actuator and electric unit (control unit) and brake fluid level switch is open or shorted.	<ul style="list-style-type: none"> <li>• Harness or connector</li> <li>• Brake fluid level switch</li> <li>• Brake fluid level</li> </ul>

#### DTC CONFIRMATION PROCEDURE

##### 1. CHECK SELF-DIAGNOSIS RESULTS

Check the self-diagnosis results.

Self-diagnosis results
BR FLUID LEVEL LOW

Is above displayed on the self-diagnosis display?

- YES >> Proceed to diagnosis procedure. Refer to [BRC-109. "Diagnosis Procedure"](#).  
 NO >> INSPECTION END

### Diagnosis Procedure

INFOID:000000001601075

#### INSPECTION PROCEDURE

##### 1. CONNECTOR INSPECTION

1. Disconnect ABS actuator and electric unit (control unit) connector E125 and brake fluid level switch connector E21.
2. Check the terminals for deformation, disconnection, looseness or damage.

Is the inspection result normal?

- YES >> GO TO 2  
 NO >> Repair or replace as necessary.

##### 2. CHECK HARNESS BETWEEN BRAKE FLUID LEVEL SWITCH AND ABS ACTUATOR AND ELECTRIC UNIT (CONTROL UNIT)

1. Check continuity between ABS actuator and electric unit (control unit) harness connector E125 (A) and brake fluid level switch harness connector E21 (B).

ABS actuator and electric unit (control unit)		Brake fluid level switch		Continuity
Connector	Terminal	Connector	Terminal	
A: E125	8	B: E21	1	Yes

2. Check continuity between ABS actuator and electric unit (control unit) harness connector E125 (A) and ground.

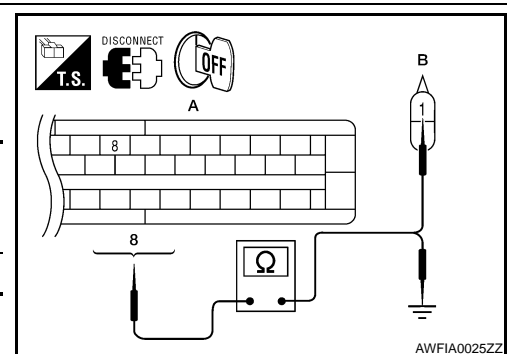

ABS actuator and electric unit (control unit)		—	Continuity
Connector	Terminal		
A: E125	8	Ground	No

Is the inspection result normal?

# C1155 BRAKE FLUID LEVEL SWITCH

[ABLS/ABS]

## < COMPONENT DIAGNOSIS >

- YES >> GO TO 3
- NO >> Repair or replace malfunctioning components.

### 3.CHECK BRAKE FLUID LEVEL SWITCH GROUND

Check continuity between brake fluid level switch harness connector E21 and ground.

Brake fluid level switch		—	Continuity
Connector	Terminal		
E21	2	Ground	Yes

Is the inspection result normal?

- YES >> GO TO 4
- NO >> Repair or replace malfunctioning components.

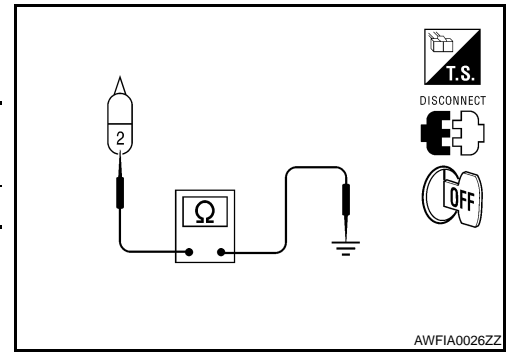

### 4.CHECK BRAKE FLUID LEVEL SWITCH

Check continuity between brake fluid level switch terminals.

Brake fluid level switch		Condition	Continuity
Terminal			
1 - 2		When brake fluid is full in the reservoir tank.	No
		When brake fluid is empty in the reservoir tank.	Yes

Is the inspection result normal?

- YES >> Perform self-diagnosis again. If the same results appear, replace ABS actuator and electric unit (control unit). Refer to [BRC-144, "Removal and Installation"](#).
- NO >> Replace brake fluid level switch.

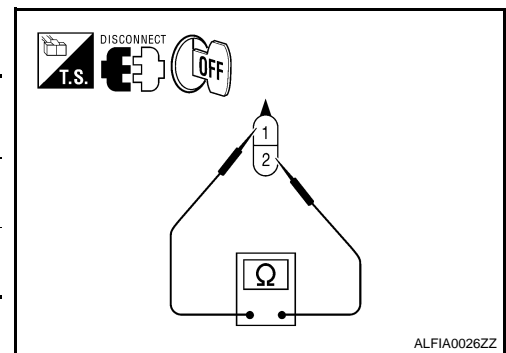

## Component Inspection

INFOID:000000001601076

### 1.CHECK BRAKE FLUID LEVEL SWITCH

1. Turn ignition switch OFF.
2. Disconnect brake fluid level switch connector.
3. Check continuity between brake fluid level switch terminals.

Brake fluid level switch		Condition	Continuity
Terminal			
1 - 2		When brake fluid is full in the reservoir tank.	No
		When brake fluid is empty in the reservoir tank.	Yes

Is the inspection result normal?

- YES >> INSPECTION END
- NO >> Replace brake fluid level switch.

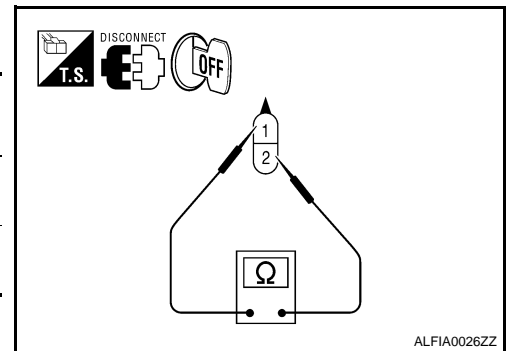

# C1164, C1165, C1166, C1167 CV/SV SYSTEM

< COMPONENT DIAGNOSIS >

[ABLS/ABS]

## C1164, C1165, C1166, C1167 CV/SV SYSTEM

### Description

INFOID:000000001601087

#### CV1, CV2 (CUT VALVE)

The cut valve shuts off the normal brake fluid path from the master cylinder, when ABLs is activated.

#### SV1, SV2 (SUCTION VALVE)

The suction valve supplies the brake fluid from the master cylinder to the pump, when ABLs is activated.

### DTC Logic

INFOID:000000001601088

### DTC DETECTION LOGIC

DTC	Display item	Malfunction detected condition	Possible cause
C1164	CV1	Switch-over solenoid valve (CV1) on the primary side is open circuit or shorted, or the control line is open or shorted to the power supply or the ground.	<ul style="list-style-type: none"><li>• Harness or connector</li><li>• ABS actuator and electric unit (control unit)</li></ul>
C1165	CV2	Switch-over solenoid valve (CV2) on the primary side is open circuit or shorted, or the control line is open or shorted to the power supply or the ground.	
C1166	SV1	Switch-over solenoid valve (SV1) on the primary side is open circuit or shorted, or the control line is open or shorted to the power supply or the ground.	
C1167	SV2	Switch-over solenoid valve (SV2) on the primary side is open circuit or shorted, or the control line is open or shorted to the power supply or the ground.	

### DTC CONFIRMATION PROCEDURE

#### 1. CHECK SELF-DIAGNOSIS RESULTS

Check the self-diagnosis results.

Self-diagnosis results
CV1
CV2
SV1
SV2

Is above displayed on the self-diagnosis display?

- YES >> Proceed to diagnosis procedure. Refer to [BRC-111. "Diagnosis Procedure"](#).  
NO >> INSPECTION END

### Diagnosis Procedure

INFOID:000000001677607

### INSPECTION PROCEDURE

#### 1. CHECK CONNECTOR

1. Turn ignition switch OFF.
2. Disconnect ABS actuator and electric unit (control unit) connector.
3. Check terminal for deformation, disconnection, looseness, and so on. If any malfunction is found, repair or replace terminal.
4. Reconnect connectors and then perform the self-diagnosis. Refer to [BRC-78. "CONSULT-III Function \(ABS\)"](#).

Is any item indicated on the self-diagnosis display?

- YES >> GO TO 2  
NO >> Poor connection of connector terminal. Repair or replace connector.

# C1164, C1165, C1166, C1167 CV/SV SYSTEM

< COMPONENT DIAGNOSIS >

[ABLS/ABS]

## 2. CHECK SOLENOID, SWITCH-OVER VALVE AND ACTUATOR RELAY POWER SUPPLY CIRCUIT

1. Turn ignition switch OFF.
2. Disconnect ABS actuator and electric unit (control unit) connector.
3. Check voltage between ABS actuator and electric unit (control unit) harness connector terminal and ground.

ABS actuator and electric unit (control unit)		—	Voltage
Connector	Terminal		
E125	32	Ground	Battery voltage

Is the inspection result normal?

- YES >> GO TO 3  
 NO >> Repair or replace malfunctioning components.

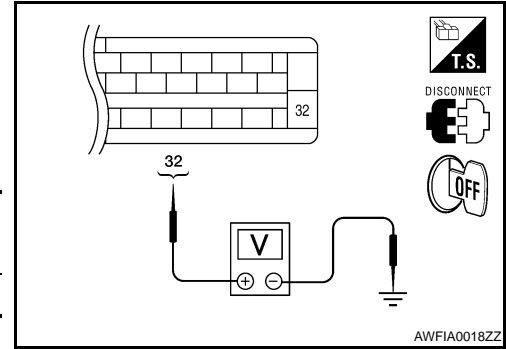

## 3. CHECK SOLENOID, SWITCH-OVER VALVE AND ACUATOR RELAY GROUND CIRCUIT

Check continuity between ABS actuator and electric unit (control unit) harness connector terminals and ground.

ABS actuator and electric unit (control unit)		—	Continuity
Connector	Terminal		
E125	16, 47	Ground	Yes

Is the inspection result normal?

- YES >> Replace ABS actuator and electric unit (control unit). Refer to [BRC-144, "Removal and Installation"](#).  
 NO >> Repair or replace malfunctioning components.

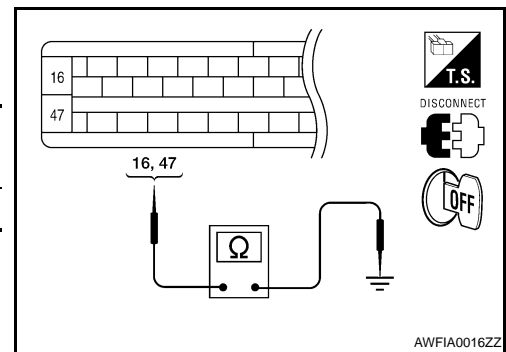

## Component Inspection

INFOID:000000001677608

### 1. CHECK ACTIVE TEST

1. Select each test menu item on "ACTIVE TEST".
2. On the display, touch "UP", "KEEP", and "DOWN", and check that the system operates as shown in the table below.

Operation		ABS solenoid valve			ABS solenoid valve (ACT)		
		UP	KEEP	DOWN	UP	ACTUA-TOR UP	ACTUA-TOR KEEP
FR RH SOL FR RH ABS SOLE- NOID (ACT)	FR RH IN SOL	OFF	ON	ON	OFF	OFF	OFF
	FR RH OUT SOL	OFF	OFF	ON*	OFF	OFF	OFF
FR LH SOL FR LH ABS SOLE- NOID (ACT)	FR LH IN SOL	OFF	ON	ON	OFF	OFF	OFF
	FR LH OUT SOL	OFF	OFF	ON*	OFF	OFF	OFF
RR RH SOL RR RH ABS SOLE- NOID (ACT)	RR RH IN SOL	OFF	ON	ON	OFF	OFF	OFF
	RR RH OUT SOL	OFF	OFF	ON*	OFF	OFF	OFF
RR LH SOL RR LH ABS SOLE- NOID (ACT)	RR LH IN SOL	OFF	ON	ON	OFF	OFF	OFF
	RR LH OUT SOL	OFF	OFF	ON*	OFF	OFF	OFF
REAR SOL	RR RH IN SOL	OFF	ON	ON	OFF	OFF	OFF
	RR RH OUT SOL	OFF	OFF	ON*	OFF	OFF	OFF
	RR LH IN SOL	OFF	ON	ON	OFF	OFF	OFF
	RR LH OUT SOL	OFF	OFF	ON*	OFF	OFF	OFF

\*: ON for 1 to 2 seconds after the touch, and then OFF



# C1164, C1165, C1166, C1167 CV/SV SYSTEM

[ABLS/ABS]

< COMPONENT DIAGNOSIS >

Is the inspection result normal?

YES >> INSPECTION END

NO >> Go to diagnosis procedure. Refer to [BRC-111, "Diagnosis Procedure"](#).

A

B

C

D

E

**BRC**

G

H

I

J

K

L

M

N

O

P

# C1187 DIFFERENTIAL LOCK CONTROL UNIT

< COMPONENT DIAGNOSIS >

[ABLS/ABS]

## C1187 DIFFERENTIAL LOCK CONTROL UNIT

### Description

INFOID:000000001677609

The differential lock control unit is connected to the ABS actuator and electric unit (control unit) via CAN lines. CAN (Controller Area Network) is a serial communication line for real time application. It is an on-vehicle multiplex communication line with high data communication speed and excellent error detection ability. Many electronic control units are equipped onto a vehicle, and each control unit shares information and links with other control units during operation (not independent). In CAN communication, control units are connected with 2 communication lines (CAN H line, CAN L line) allowing a high rate of information transmission with less wiring. Each control unit transmits/receives data but selectively reads required data only.

### DTC Logic

INFOID:000000001677610

### DTC DETECTION LOGIC

DTC	Display item	Malfunction detected condition	Possible cause
C1187	ABS DIFLOCK CONTROL- LER NG	Differential lock controller malfunction.	<ul style="list-style-type: none"><li>• Harness or connector</li><li>• CAN communication line</li><li>• Differential lock control unit</li><li>• ABS actuator and electric unit (control unit)</li></ul>

### DTC CONFIRMATION PROCEDURE

#### 1. CHECK SELF-DIAGNOSIS RESULTS

Check the self-diagnosis results.

Self-diagnosis results

ABS DIFLOCK CONTROLLER NG

Is above displayed on the self-diagnosis display?

- YES >> Proceed to diagnosis procedure. Refer to [BRC-114, "Diagnosis Procedure"](#).  
NO >> INSPECTION END

### Diagnosis Procedure

INFOID:000000001677611

### INSPECTION PROCEDURE

#### 1. CHECK CONNECTOR

1. Turn ignition switch OFF and disconnect ABS actuator and electric unit (control unit) connector E125, check terminal for deformation, disconnection, looseness, and so on. If any malfunction is found, repair or replace terminal.
2. Reconnect connector and perform self-diagnosis.

Self-diagnosis results

ABS DIFLOCK CONTROLLER NG

Is above displayed on the self-diagnosis display?

- YES >> Refer to [LAN-14, "Trouble Diagnosis Flow Chart"](#).  
NO >> INSPECTION END

# U1000 CAN COMM CIRCUIT

< COMPONENT DIAGNOSIS >

[ABLS/ABS]

## U1000 CAN COMM CIRCUIT

### Description

INFOID:000000001601102

CAN (Controller Area Network) is a serial communication line for real time application. It is an on-vehicle multiplex communication line with high data communication speed and excellent error detection ability. Many electronic control units are equipped onto a vehicle, and each control unit shares information and links with other control units during operation (not independent). In CAN communication, control units are connected with 2 communication lines (CAN H line, CAN L line) allowing a high rate of information transmission with less wiring. Each control unit transmits/receives data but selectively reads required data only.

### DTC Logic

INFOID:000000001601103

### DTC DETECTION LOGIC

DTC	Display item	Malfunction detected condition	Possible cause
U1000	CAN COMM CIRCUIT	When ABS actuator and electric unit (control unit) is not transmitting or receiving CAN communication signal for 2 seconds or more.	<ul style="list-style-type: none"><li>• CAN communication line</li><li>• ABS actuator and electric unit (control unit)</li></ul>

BRC

### Diagnosis Procedure

INFOID:000000001601104

#### INSPECTION PROCEDURE

##### 1. CHECK CONNECTOR

1. Turn ignition switch OFF, disconnect the ABS actuator and electric unit (control unit) connector, and check the terminals for deformation, disconnection, looseness, and so on. If there is a malfunction, repair or replace the terminal.
2. Reconnect connector and perform self-diagnosis.

Is "CAN COMM CIRCUIT" displayed in self-diagnosis display items?

- YES >> Print out the self-diagnostic results, and refer to [LAN-14, "Trouble Diagnosis Flow Chart"](#).
- NO >> Connector terminal is loose, damaged, open, or shorted.

# ABS WARNING LAMP

[ABLS/ABS]

< COMPONENT DIAGNOSIS >

## ABS WARNING LAMP

### Description

INFOID:000000001601110

×: ON –: OFF

Condition	ABS warning lamp
Ignition switch OFF	–
For 1 second after turning ON ignition switch	×
1 second later after turning ON ignition switch	–
ABS function is malfunctioning.	×
EBD function is malfunctioning.	×

### Component Function Check

INFOID:000000001601111

#### 1.CHECK ABS WARNING LAMP OPERATION

Check that the lamp illuminates for approximately 1 second after the ignition switch is turned ON.

Is the inspection result normal?

YES >> INSPECTION END

NO >> Go to diagnosis procedure. Refer to [BRC-116. "Diagnosis Procedure"](#).

### Diagnosis Procedure

INFOID:000000001601112

#### 1.CHECK SELF-DIAGNOSIS

Perform ABS actuator and electric unit (control unit) self-diagnosis. Refer to [BRC-78. "CONSULT-III Function \(ABS\)"](#).

Is the inspection result normal?

YES >> GO TO 2

NO >> Check items displayed by self-diagnosis.

#### 2.CHECK COMBINATION METER

Check if the indication and operation of combination meter are normal. Refer to [MWI-26. "Diagnosis Description"](#).

Is the inspection result normal?

YES >> Replace ABS actuator and electric unit (control unit). Refer to [BRC-144. "Removal and Installation"](#).

NO >> Replace combination meter. Refer to [MWI-72. "Removal and Installation"](#).

# BRAKE WARNING LAMP

< COMPONENT DIAGNOSIS >

[ABLS/ABS]

## BRAKE WARNING LAMP

### Description

INFOID:000000001601113

×: ON –: OFF

Condition	Brake warning lamp (Note 1)
Ignition switch OFF	–
For 1 second after turning ON ignition switch	× (Note 2)
1 second later after turning ON ignition switch	× (Note 2)
EBD function is malfunctioning.	×

#### NOTE:

- 1: Brake warning lamp will turn on in case of parking brake operation (when switch is ON) or of brake fluid level switch operation (when brake fluid is insufficient).
- 2: After starting engine, brake warning lamp is turned off.

### Component Function Check

INFOID:000000001601114

BRC

#### 1. BRAKE WARNING LAMP OPERATION CHECK

Check that the lamp illuminates for approximately 1 second after the ignition switch is turned ON.

Is the inspection result normal?

YES >> INSPECTION END

NO >> Go to diagnosis procedure. Refer to [BRC-117, "Diagnosis Procedure"](#).

### Diagnosis Procedure

INFOID:000000001601115

#### 1. CHECK SELF-DIAGNOSIS

Perform ABS actuator and electric unit (control unit) self-diagnosis.

Is the inspection result normal?

YES >> GO TO 2

NO >> Check items displayed by self-diagnosis.

#### 2. CHECK COMBINATION METER

Check if the indication and operation of combination meter are normal. Refer to [MWI-26, "Diagnosis Description"](#).

Is the inspection result normal?

YES >> Replace ABS actuator and electric unit (control unit). Refer to [BRC-144, "Removal and Installation"](#).

NO >> Replace combination meter. Refer to [MWI-72, "Removal and Installation"](#).

# SLIP INDICATOR LAMP

[ABLS/ABS]

< COMPONENT DIAGNOSIS >

## SLIP INDICATOR LAMP

### Description

INFOID:000000001601119

×: ON –: OFF

Condition	SLIP indicator lamp
Ignition switch OFF	–
For 1 second after turning ON ignition switch	×
1 second later after turning ON ignition switch	–
ABLS function is active.	×

### Component Function Check

INFOID:000000001601120

#### 1.CHECK SLIP INDICATOR LAMP OPERATION

Check that the lamp illuminates for approximately 1 second after the ignition switch is turned ON.

Is the inspection result normal?

YES >> INSPECTION END

NO >> Go to diagnosis procedure. Refer to [BRC-118, "Diagnosis Procedure"](#).

### Diagnosis Procedure

INFOID:000000001601121

#### 1.CHECK SELF-DIAGNOSIS

Perform ABS actuator and electric unit (control unit) self-diagnosis. Refer to [BRC-78, "CONSULT-III Function \(ABS\)"](#).

Is the inspection result normal?

YES >> GO TO 2

NO >> Check items displayed by self-diagnosis.

#### 2.CHECK COMBINATION METER

Check if the indication and operation of combination meter are normal. Refer to [MWI-26, "Diagnosis Description"](#).

Is the inspection result normal?

YES >> Replace ABS actuator and electric unit (control unit). Refer to [BRC-144, "Removal and Installation"](#).

NO >> Replace combination meter. Refer to [MWI-72, "Removal and Installation"](#).

# ABS ACTUATOR AND ELECTRIC UNIT (CONTROL UNIT)

< ECU DIAGNOSIS >

[ABLS/ABS]

## ECU DIAGNOSIS

### ABS ACTUATOR AND ELECTRIC UNIT (CONTROL UNIT)

#### Reference Value

INFOID:000000001601122

#### VALUES ON THE DIAGNOSIS TOOL

#### CAUTION:

The display shows the control unit calculation data, so a normal value might be displayed even in the event the output circuit (harness) is open or short-circuited.

#### CONSULT-III MONITOR ITEM

Monitor item	Display content	Data monitor	
		Condition	Reference value in normal operation
FR LH SENSOR	Wheel speed	0 [km/h (MPH)]	Vehicle stopped
		Nearly matches the speed meter display (± 10% or less)	Vehicle running (Note 1)
FR RH SENSOR	Wheel speed	0 [km/h (MPH)]	Vehicle stopped
		Nearly matches the speed meter display (± 10% or less)	Vehicle running (Note 1)
RR LH SENSOR	Wheel speed	0 [km/h (MPH)]	Vehicle stopped
		Nearly matches the speed meter display (± 10% or less)	Vehicle running (Note 1)
RR RH SENSOR	Wheel speed	0 [km/h (MPH)]	Vehicle stopped
		Nearly matches the speed meter display (± 10% or less)	Vehicle running (Note 1)
STOP LAMP SW	Stop lamp switch signal status	When brake pedal is depressed	ON
		When brake pedal is released	OFF
BATTERY VOLT	Battery voltage supplied to the ABS actuator and electric unit (control unit)	Ignition switch ON	10 – 16 V
GEAR	Gear position determined by TCM	1st gear	1
		2nd gear	2
		3rd gear	3
		4th gear	4
		5th gear	5
SLCT LVR POSI	A/T selector lever position	P position	P
		R position	R
		N position	N
		D position	D
ACCEL POS SIG	Throttle actuator opening/closing is displayed (linked with accelerator pedal)	Accelerator pedal not depressed (ignition switch is ON)	0 %
		Accelerator pedal depressed (ignition switch is ON)	0 - 100 %
PRESS SENSOR	Brake fluid pressure detected by front pressure sensor	With ignition switch turned ON and brake pedal released	Approx. 0 bar
		With ignition switch turned ON and brake pedal depressed	-40 to 300 bar
ENGINE SPEED	With engine running	With engine stopped	0 rpm
		Engine running	Almost in accordance with tachometer display
FLUID LEV SW	Brake fluid level switch signal status	When brake fluid level switch ON	ON
		When brake fluid level switch OFF	OFF

# ABS ACTUATOR AND ELECTRIC UNIT (CONTROL UNIT)

< ECU DIAGNOSIS >

[ABLS/ABS]

Monitor item	Display content	Data monitor	
		Condition	Reference value in normal operation
FR RH IN SOL	Operation status of each solenoid valve	Actuator (solenoid valve) is active ("ACTIVE TEST" with CONSULT-III) or actuator relay is inactive (in fail-safe mode)	ON
		When the actuator (solenoid valve) is not active and actuator relay is active (ignition switch ON)	OFF
FR RH OUT SOL	Operation status of each solenoid valve	Actuator (solenoid valve) is active ("ACTIVE TEST" with CONSULT-III) or actuator relay is inactive (in fail-safe mode)	ON
		When the actuator (solenoid valve) is not active and actuator relay is active (ignition switch ON)	OFF
FR LH IN SOL	Operation status of each solenoid valve	Actuator (solenoid valve) is active ("ACTIVE TEST" with CONSULT-III) or actuator relay is inactive (in fail-safe mode)	ON
		When the actuator (solenoid valve) is not active and actuator relay is active (ignition switch ON)	OFF
FR LH OUT SOL	Operation status of each solenoid valve	Actuator (solenoid valve) is active ("ACTIVE TEST" with CONSULT-III) or actuator relay is inactive (in fail-safe mode)	ON
		When the actuator (solenoid valve) is not active and actuator relay is active (ignition switch ON)	OFF
RR RH IN SOL	Operation status of each solenoid valve	Actuator (solenoid valve) is active ("ACTIVE TEST" with CONSULT-III) or actuator relay is inactive (in fail-safe mode)	ON
		When the actuator (solenoid valve) is not active and actuator relay is active (ignition switch ON)	OFF
RR RH OUT SOL	Operation status of each solenoid valve	Actuator (solenoid valve) is active ("ACTIVE TEST" with CONSULT-III) or actuator relay is inactive (in fail-safe mode)	ON
		When the actuator (solenoid valve) is not active and actuator relay is active (ignition switch ON)	OFF
RR LH IN SOL	Operation status of each solenoid valve	Actuator (solenoid valve) is active ("ACTIVE TEST" with CONSULT-III) or actuator relay is inactive (in fail-safe mode)	ON
		When the actuator (solenoid valve) is not active and actuator relay is active (ignition switch ON)	OFF
RR LH OUT SOL	Operation status of each solenoid valve	Actuator (solenoid valve) is active ("ACTIVE TEST" with CONSULT-III) or actuator relay is inactive (in fail-safe mode)	ON
		When the actuator (solenoid valve) is not active and actuator relay is active (ignition switch ON)	OFF
MOTOR RELAY	Motor and motor relay operation	When the motor relay and motor are operating	ON
		When the motor relay and motor are not operating	OFF
ACTUATOR RLY	Actuator relay operation	When the actuator relay is operating	ON
		When the actuator relay is not operating	OFF



# ABS ACTUATOR AND ELECTRIC UNIT (CONTROL UNIT)

< ECU DIAGNOSIS >

[ABLS/ABS]

Monitor item	Display content	Data monitor		
		Condition	Reference value in normal operation	
ABS WARN LAMP	ABS warning lamp (Note 2)	When ABS warning lamp is ON	ON	A
		When ABS warning lamp is OFF	OFF	B
SLIP LAMP	SLIP indicator lamp (Note 2)	When SLIP indicator lamp is ON	ON	C
		When SLIP indicator lamp is OFF	OFF	
EBD SIGNAL	EBD operation	EBD is active	ON	D
		EBD is inactive	OFF	
ABS SIGNAL	ABS operation	ABS is active	ON	E
		ABS is inactive	OFF	
TCS SIGNAL	ABLS operation	ABLS is active	ON	E
		ABLS is inactive	OFF	
EBD FAIL SIG	EBD fail-safe signal	In EBD fail-safe	ON	BRC
		EBD is normal	OFF	
ABS FAIL SIG	ABS fail-safe signal	In ABS fail-safe	ON	G
		ABS is normal	OFF	
TCS FAIL SIG	ABLS fail-safe signal	In ABLS fail-safe	ON	H
		ABLS is normal	OFF	
CRANKING SIG	Crank operation	Crank is active	ON	I
		Crank is inactive	OFF	
CV1	Switch-over valve	When actuator (switch-over valve) is active ("ACTIVE TEST" with CONSULT-III) or actuator relay is inactive (when in fail-safe mode)	ON	J
		When actuator (switch-over valve) is not active and actuator relay is active (ignition switch ON)	OFF	
CV2	Switch-over valve	When actuator (switch-over valve) is active ("ACTIVE TEST" with CONSULT-III) or actuator relay is inactive (when in fail-safe mode)	ON	K
		When actuator (switch-over valve) is not active and actuator relay is active (ignition switch ON)	OFF	
SV1	Switch-over valve	When actuator (switch-over valve) is active ("ACTIVE TEST" with CONSULT-III) or actuator relay is inactive (when in fail-safe mode)	ON	L
		When actuator (switch-over valve) is not active and actuator relay is active (ignition switch ON)	OFF	
SV2	Switch-over valve	When actuator (switch-over valve) is active ("ACTIVE TEST" with CONSULT-III) or actuator relay is inactive (when in fail-safe mode)	ON	M
		When actuator (switch-over valve) is not active and actuator relay is active (ignition switch ON)	OFF	
DECEL G-SEN	Longitudinal acceleration detected by Decel G-Sensor	Vehicle stopped	Approx. 0 G	N
		Vehicle running	-1.7 to 1.7 G	

# ABS ACTUATOR AND ELECTRIC UNIT (CONTROL UNIT)

< ECU DIAGNOSIS >

[ABLS/ABS]

Monitor item	Display content	Data monitor	
		Condition	Reference value in normal operation
EBD WARN LAMP	EBD warning lamp (Note 2)	When EBD warning lamp is ON	ON
		When EBD warning lamp is OFF	OFF
N POSI SIG	PNP switch signal ON/OFF condition	A/T shift position = N position	ON
		A/T shift position = other than N position	OFF
P POSI SIG	PNP switch signal ON/OFF condition	A/T shift position = P position	ON
		A/T shift position = other than P position	OFF
R POSI SIG	PNP switch signal ON/OFF condition	A/T shift position = R position	ON
		A/T shift position = other than R position	OFF
2WD/4WD	Drive axle	2WD model	2WD
		4WD model	4WD
PRESS SEN2	Brake fluid pressure detected by rear pressure sensor	With ignition switch turned ON and brake pedal released	Approx. 0 bar
		With ignition switch turned ON and brake pedal depressed	-40 to 300 bar

**NOTE:**

- 1: Confirm tire pressure is normal.
- 2: On and off timing for warning lamp and indicator lamp.
- ABS warning lamp: Refer to [BRC-116, "Description"](#).
- Brake warning lamp: Refer to [BRC-117, "Description"](#).
- SLIP indicator lamp: Refer to [BRC-118, "Description"](#).

**TERMINAL LAYOUT**

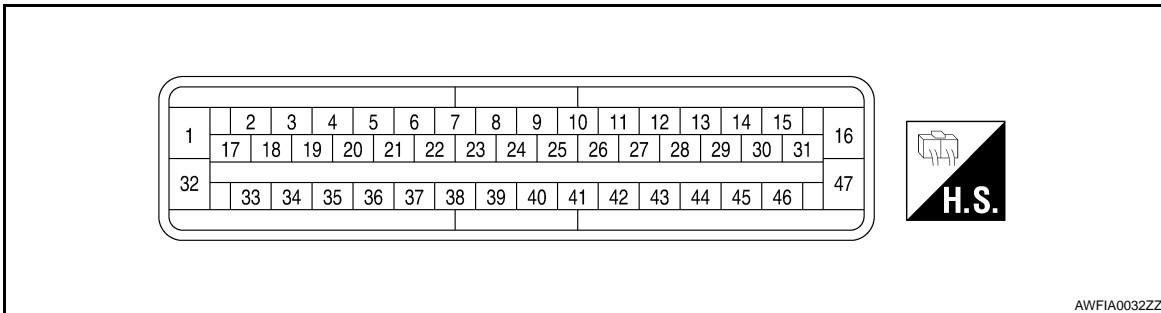

# ABS ACTUATOR AND ELECTRIC UNIT (CONTROL UNIT)

< ECU DIAGNOSIS >

[ABLS/ABS]

## Wiring Diagram

INFOID:000000001601123

DATA LINE

### BRAKE CONTROL SYSTEM - ABL5

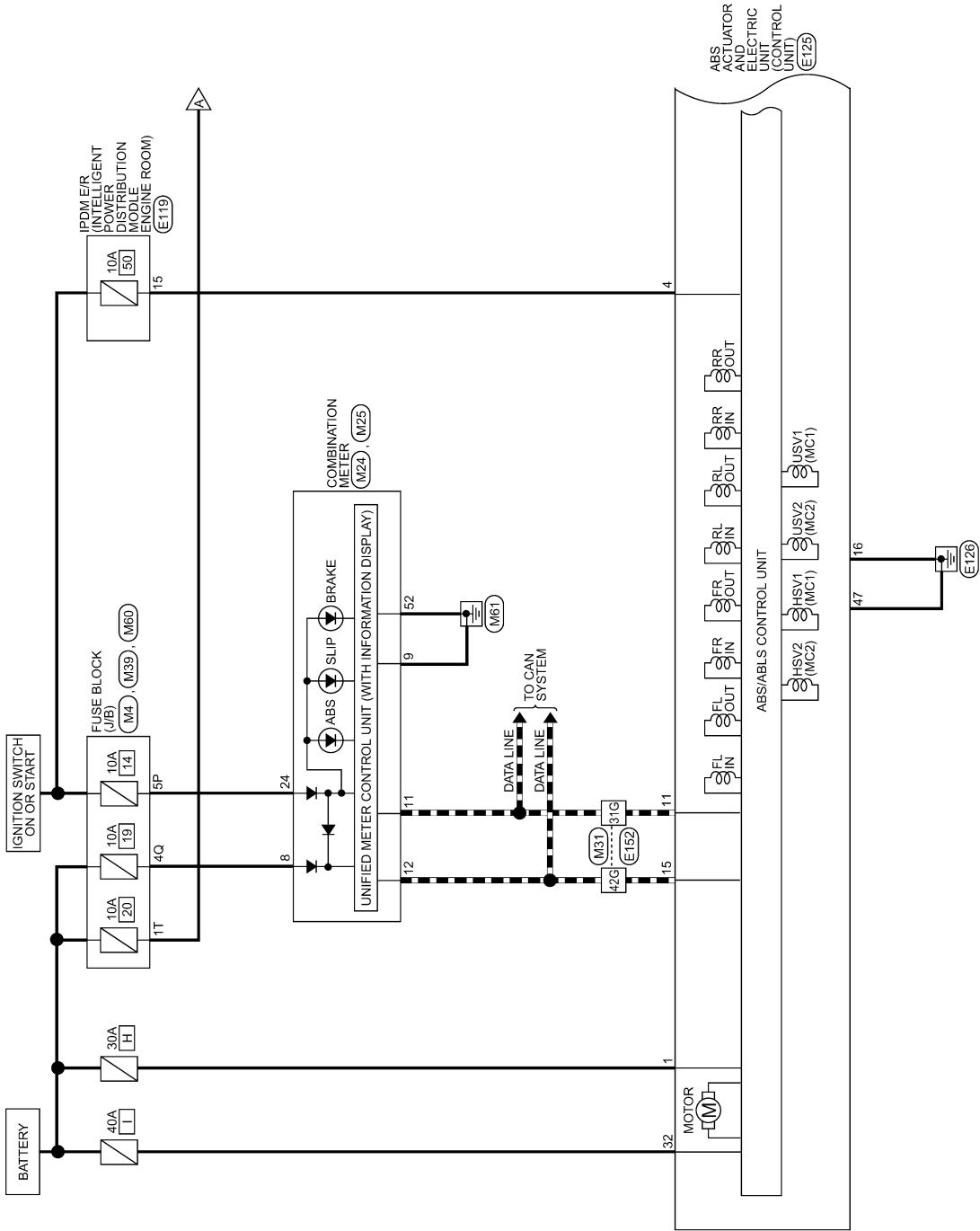

A  
B  
C  
D  
E  
BRC  
G  
H  
I  
J  
K  
L  
M  
N  
O  
P

AWFWA0003GI

# ABS ACTUATOR AND ELECTRIC UNIT (CONTROL UNIT)

< ECU DIAGNOSIS >

[ABLS/ABS]

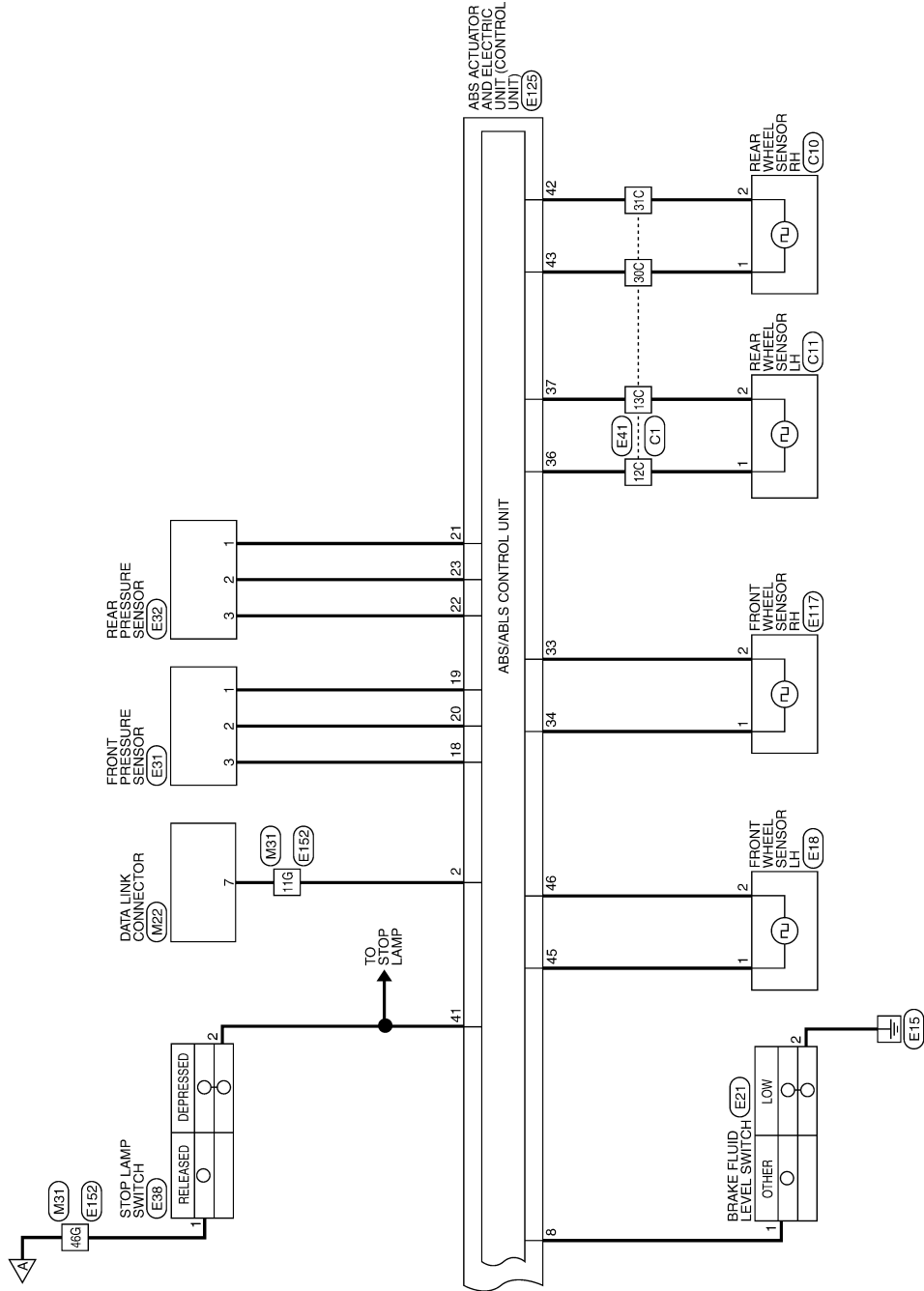

AWFWA0004GI

# ABS ACTUATOR AND ELECTRIC UNIT (CONTROL UNIT)

< ECU DIAGNOSIS >

[ABLS/ABS]

## BRAKE CONTROL SYSTEM - ABL5 CONNECTORS

Connector No.	M4
Connector Name	FUSE BLOCK (J/B)
Connector Color	WHITE



Terminal No.	Color of Wire	Signal Name
5P	O/L	-

Connector No.	M22
Connector Name	DATA LINK CONNECTOR
Connector Color	WHITE

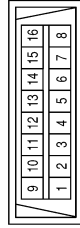

Terminal No.	Color of Wire	Signal Name
7	G/W	K-LINE

Connector No.	M24
Connector Name	COMBINATION METER
Connector Color	WHITE

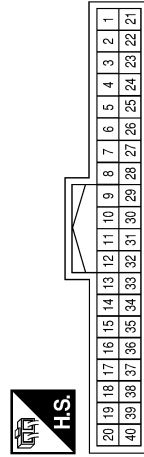

Terminal No.	Color of Wire	Signal Name
8	Y/R	-
9	B	-
11	L	CAN-H
12	P	CAN-L
24	O/L	-

Connector No.	M25
Connector Name	COMBINATION METER
Connector Color	WHITE

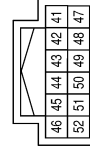

Terminal No.	Color of Wire	Signal Name
52	B	-

Connector No.	M31
Connector Name	WIRE TO WIRE
Connector Color	WHITE

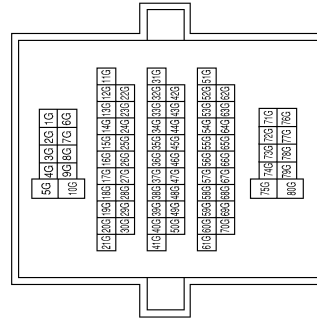

Terminal No.	Color of Wire	Signal Name
11G	G/W	-
31G	L	-
42G	P	-
46G	R/Y	-

A  
B  
C  
D  
E  
BRC  
G  
H  
I  
J  
K  
L  
M  
N  
O  
P

# ABS ACTUATOR AND ELECTRIC UNIT (CONTROL UNIT)

< ECU DIAGNOSIS >

[ABLS/ABS]

Connector No.	E18
Connector Name	FRONT WHEEL SENSOR LH
Connector Color	GRAY



Terminal No.	Color of Wire	Signal Name
1	G/O	-
2	BR/W	-

Connector No.	M60
Connector Name	FUSE BLOCK (J/B)
Connector Color	WHITE



Terminal No.	Color of Wire	Signal Name
1T	R/Y	-

Connector No.	M39
Connector Name	FUSE BLOCK (J/B)
Connector Color	WHITE

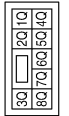

Terminal No.	Color of Wire	Signal Name
4Q	Y/R	-

Connector No.	E38
Connector Name	STOP LAMP SWITCH (FLOOR SHIFT)
Connector Color	BLACK



Terminal No.	Color of Wire	Signal Name
1	R/Y	-
2	R/B	-

Connector No.	E31
Connector Name	FRONT PRESSURE SENSOR
Connector Color	GRAY

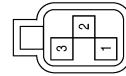

Terminal No.	Color of Wire	Signal Name
1	R	GND
2	R/L	SIG
3	R/W	POWER

Connector No.	E21
Connector Name	BRAKE FLUID LEVEL SWITCH
Connector Color	GRAY



Terminal No.	Color of Wire	Signal Name
1	P/B	-
2	B	-

AWFIA0054GB

# ABS ACTUATOR AND ELECTRIC UNIT (CONTROL UNIT)

< ECU DIAGNOSIS >

[ABLS/ABS]

Connector No.	E117
Connector Name	FRONT WHEEL SENSOR RH
Connector Color	GRAY



Terminal No.	Color of Wire	Signal Name
1	B/R	-
2	BR	-

Connector No.	E41
Connector Name	WIRE TO WIRE
Connector Color	GRAY

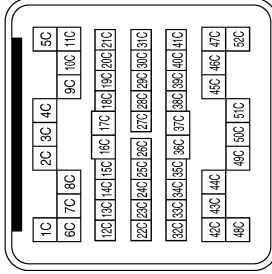

Terminal No.	Color of Wire	Signal Name
12C	L	-
13C	P	-
30C	G/Y	-
31C	V	-

Connector No.	E38
Connector Name	STOP LAMP SWITCH (COLUMN SHIFT)
Connector Color	WHITE



Terminal No.	Color of Wire	Signal Name
1	R/Y	-
2	R/B	-

Connector No.	E119
Connector Name	IPDM E/R (INTELLIGENT POWER DISTRIBUTION MODULE ENGINE ROOM)
Connector Color	WHITE

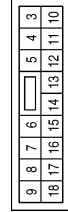

Terminal No.	Color of Wire	Signal Name
15	G/R	ABS IGN SUPPLY

A  
B  
C  
D  
E  
BRC  
G  
H  
I  
J  
K  
L  
M  
N  
O  
P

# ABS ACTUATOR AND ELECTRIC UNIT (CONTROL UNIT)

< ECU DIAGNOSIS >

[ABLS/ABS]

Connector No.	E125
Connector Name	ABS ACTUATOR AND ELECTRIC UNIT (CONTROL UNIT)
Connector Color	BLACK

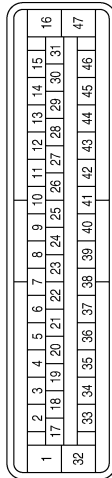

Terminal No.	Color of Wire	Signal Name
1	Y	MOTOR_SUPPLY
2	G/W	DIAG_K
4	G/R	IGN
8	P/B	FLUID_LEVEL_SW

Terminal No.	Color of Wire	Signal Name
11	L	CAN-H
15	P	CAN-L
16	B	VALVE_ECU_GND
18	R/W	PS1 - SUPPLY
19	R	PS1 - GND
20	R/L	PS1_SIGNAL
21	R/B	PS2_GND
22	W/L	PS2_SUPPLY
23	W/O	PS2_SIGNAL
32	B/Y	VALVE_ECU_SUPPLY
33	BR	WSS_FR_SIG
34	B/R	WSS_FR_PWR
36	L	WSS_RL_PWR
37	P	WSS_RL_SIG
41	R/B	BLS
45	G/O	WSS_FL_PWR
46	BR/W	WSS_FL_SIG
47	B	MOTOR_GND

Connector No.	E152
Connector Name	WIRE TO WIRE
Connector Color	WHITE

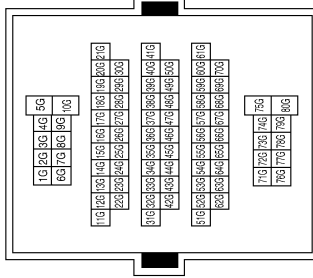

Terminal No.	Color of Wire	Signal Name
11G	G/W	-
31G	L	-
42G	P	-
46G	R/Y	-

Connector No.	C1
Connector Name	WIRE TO WIRE
Connector Color	GRAY

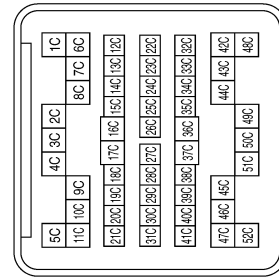

Terminal No.	Color of Wire	Signal Name
12C	L	-
13C	P	-
30C	G/Y	-
31C	V	-

Connector No.	C10
Connector Name	REAR WHEEL SENSOR RH
Connector Color	BROWN



Terminal No.	Color of Wire	Signal Name
1	G/Y	-
2	V	-



# ABS ACTUATOR AND ELECTRIC UNIT (CONTROL UNIT)

< ECU DIAGNOSIS >

[ABLS/ABS]

A  
B  
C  
D  
E

**BRC**

G  
H  
I  
J  
K  
L  
M  
N  
O  
P

Connector No.	C11
Connector Name	REAR WHEEL SENSOR LH
Connector Color	BROWN



Terminal No.	Color of Wire	Signal Name
1	L	-
2	P	-

AWFIA0057GB

INFOID:000000001601124

## Fail-Safe

### **CAUTION:**

**If the Fail-Safe function is activated, perform the Self Diagnosis for ABS/ABLS system.**

## ABS/EBD SYSTEM

In case of an electrical malfunction with the ABS, the ABS warning lamp will turn on. In case of an electrical malfunction with the EBD system, the brake warning lamp and ABS warning lamp will turn on.

# ABS ACTUATOR AND ELECTRIC UNIT (CONTROL UNIT)

< ECU DIAGNOSIS >

[ABLS/ABS]

The system will revert to one of the following conditions of the Fail-Safe function.

1. For ABS malfunction, only the EBD is operative and the condition of the vehicle is the same condition of vehicles without ABS/ABLS system.
2. For EBD malfunction, the EBD and ABS become inoperative, and the condition of the vehicle is the same as the condition of vehicles without ABS/ABLS or EBD system.

## ABLS SYSTEM

In case of an ABLS system malfunction, the ABS warning lamp will turn on and only the EBD is operative. The condition of the vehicle is the same as the condition of vehicles without ABS/ABLS system.

## DTC No. Index

INFOID:000000001601125

DTC	Items (CONSULT screen terms)	Reference
C1101	RR RH SENSOR-1	<a href="#">BRC-82, "Description"</a>
C1102	RR LH SENSOR-1	
C1103	FR RH SENSOR-1	
C1104	FR LH SENSOR-1	
C1105	RR RH SENSOR-2	<a href="#">BRC-85, "Description"</a>
C1106	RR LH SENSOR-2	
C1107	FR RH SENSOR-2	
C1108	FR LH SENSOR-2	
C1109	BATTERY VOLTAGE [ABNORMAL]	<a href="#">BRC-88, "Description"</a>
C1110	CONTROLLER FAILURE	<a href="#">BRC-90, "DTC Logic"</a>
C1111	PUMP MOTOR	<a href="#">BRC-91, "Description"</a>
C1113	G-SENSOR	<a href="#">BRC-90, "DTC Logic"</a>
C1115	ABS SENSOR [ABNORMAL SIGNAL]	<a href="#">BRC-93, "Description"</a>
C1116	STOP LAMP SW	<a href="#">BRC-96, "Description"</a>
C1120	FR LH IN ABS SOL	<a href="#">BRC-97, "Description"</a>
C1121	FR LH OUT ABS SOL	<a href="#">BRC-100, "Description"</a>
C1122	FR RH IN ABS SOL	<a href="#">BRC-97, "Description"</a>
C1123	FR RH OUT ABS SOL	<a href="#">BRC-100, "Description"</a>
C1124	RR LH IN ABS SOL	<a href="#">BRC-97, "Description"</a>
C1125	RR LH OUT ABS SOL	<a href="#">BRC-100, "Description"</a>
C1126	RR RH IN ABS SOL	<a href="#">BRC-97, "Description"</a>
C1127	RR RH OUT ABS SOL	<a href="#">BRC-100, "Description"</a>
C1130	ENGINE SIGNAL 1	<a href="#">BRC-103, "Description"</a>
C1131	ENGINE SIGNAL 2	
C1136	ENGINE SIGNAL 6	
C1140	ACTUATOR RLY	<a href="#">BRC-104, "Description"</a>
C1142	PRESS SEN CIRCUIT	<a href="#">BRC-106, "Description"</a>
C1155	BR FLUID LEVEL LOW	<a href="#">BRC-109, "Description"</a>
C1160	DECEL G SEN SET	<a href="#">BRC-90, "DTC Logic"</a>
C1164	CV1	<a href="#">BRC-111, "Description"</a>
C1165	CV2	
C1166	SV1	
C1167	SV2	
C1170	VARIANT CODING	<a href="#">BRC-90, "DTC Logic"</a>

# ABS ACTUATOR AND ELECTRIC UNIT (CONTROL UNIT)

< ECU DIAGNOSIS >

[ABLS/ABS]

DTC	Items (CONSULT screen terms)	Reference
C1187	ABS DIFLOCK CONTROLLER NG	<a href="#">BRC-114. "Description"</a>
U1000	CAN COMM CIRCUIT	<a href="#">BRC-115. "Description"</a>

A

B

C

D

E

**BRC**

G

H

I

J

K

L

M

N

O

P

# SYMPTOM DIAGNOSIS

## ABLS/ABS

### Symptom Table

INFOID:000000001601126

If ABS warning lamp turns ON, perform self-diagnosis.

Symptom	Check item	Reference
Excessive ABS function operation frequency	Brake force distribution	<a href="#">BRC-133, "Diagnosis Procedure"</a>
	Looseness of front and rear axle	
	Wheel sensor and rotor system	
Unexpected pedal reaction	Brake pedal stroke	<a href="#">BRC-134, "Diagnosis Procedure"</a>
	Make sure the braking force is sufficient when the ABS is not operating.	
The braking distance is long	Check stopping distance when the ABS is not operating.	<a href="#">BRC-135, "Diagnosis Procedure"</a>
ABS function does not operate (Note 1)	ABS actuator and electric unit (control unit)	<a href="#">BRC-136, "Diagnosis Procedure"</a>
Pedal vibration or ABS operation sound occurs (Note 2)	Brake pedal	<a href="#">BRC-137, "Diagnosis Procedure"</a>
	ABS actuator and electric unit (control unit)	

**NOTE:**

- 1: The ABS does not operate when the speed is 10 km/h (6 MPH) or less.
- 2: Under the following conditions, ABS is activated and vibration is felt when brake pedal is lightly depressed. However, this is normal.
  - When shifting gears
  - When driving on slippery road
  - During cornering at high speed
  - When passing over bumps or grooves [at approximately 50 mm (1.97 in) or more]
  - When pulling away just after starting engine [at approximately 10 km/h (6 MPH) or higher]

# EXCESSIVE ABS FUNCTION OPERATION FREQUENCY

< SYMPTOM DIAGNOSIS >

[ABLS/ABS]

## EXCESSIVE ABS FUNCTION OPERATION FREQUENCY

### Diagnosis Procedure

INFOID:000000001601127

#### 1.CHECK START

Check front and rear brake force distribution using a brake tester.

Is the inspection result normal?

YES >> GO TO 2

NO >> Check brake system.

#### 2.CHECK FRONT AND REAR AXLE

Make sure that there is no excessive play in the front and rear axles. Refer to front: [FAX-5. "On-Vehicle Inspection and Service"](#), Rear: [RAX-5. "On-Vehicle Inspection"](#).

Is the inspection result normal?

YES >> GO TO 3

NO >> Repair or replace malfunctioning components.

#### 3.CHECK WHEEL SENSOR AND SENSOR ROTOR

Check the following.

- Wheel sensor installation for damage.
- Sensor rotor installation for damage.
- Wheel sensor connector connection.
- Wheel sensor harness inspection.

Is the inspection result normal?

YES >> GO TO 4

NO >> • Replace wheel sensor or sensor rotor. Refer to [BRC-142. "Removal and Installation"](#).  
• Repair harness.

#### 4.CHECK ABS WARNING LAMP DISPLAY

Make sure that the ABS warning lamp is turned off after the ignition switch is turned ON or when driving.

Is the ABS warning lamp illuminated?

YES >> Perform self-diagnosis. Refer to [BRC-78. "CONSULT-III Function \(ABS\)"](#).

NO >> Normal

A  
B  
C  
D  
E  
BRC  
G  
H  
I  
J  
K  
L  
M  
N  
O  
P

# UNEXPECTED PEDAL REACTION

[ABLS/ABS]

< SYMPTOM DIAGNOSIS >

## UNEXPECTED PEDAL REACTION

### Diagnosis Procedure

INFOID:000000001601128

#### 1.CHECK BRAKE PEDAL STROKE

Check brake pedal stroke. Refer to [BR-14, "Inspection and Adjustment"](#).

Is the stroke too large?

- YES >> • Bleed air from brake tube and hose. Refer to [BR-16, "Bleeding Brake System"](#).  
• Check brake pedal, brake booster, and master cylinder for mount play, looseness, brake system fluid leakage, etc. Refer to [BR-14, "Inspection and Adjustment"](#) (brake pedal), [BR-11, "On Board Inspection"](#) (master cylinder), [BR-10, "Inspection"](#) (brake booster).

NO >> GO TO 2

#### 2.CHECK FUNCTION

Disconnect ABS actuator and electric unit (control unit) connector to deactivate ABS. Check if braking force is normal in this condition. Connect connector after inspection.

Is the inspection result normal?

- YES >> Normal  
NO >> Check brake system.

# THE BRAKING DISTANCE IS LONG

[ABLS/ABS]

< SYMPTOM DIAGNOSIS >

## THE BRAKING DISTANCE IS LONG

### Diagnosis Procedure

INFOID:000000001601129

#### **CAUTION:**

The stopping distance on slippery road surfaces might be longer with the ABS operating than when the ABS is not operating.

#### **1**.CHECK FUNCTION

Turn ignition switch OFF and disconnect ABS actuator and electric unit (control unit) connector to deactivate ABS. In this condition, check stopping distance. After inspection, connect connector.

Is the inspection result normal?

YES >> Normal

NO >> Check brake system.

A

B

C

D

E

**BRC**

G

H

I

J

K

L

M

N

O

P

## ABS FUNCTION DOES NOT OPERATE

< SYMPTOM DIAGNOSIS >

[ABLS/ABS]

---

### ABS FUNCTION DOES NOT OPERATE

#### Diagnosis Procedure

INFOID:000000001601130

**CAUTION:**

**ABS does not operate when speed is 10 km/h (6 MPH) or lower.**

**1**.CHECK ABS WARNING LAMP DISPLAY

---

Make sure that the ABS warning lamp turns OFF after ignition switch is turned ON or when driving.

Is the inspection result normal?

YES >> Normal

NO >> Perform self-diagnosis. Refer to [BRC-78, "CONSULT-III Function \(ABS\)"](#).



# PEDAL VIBRATION OR ABS OPERATION SOUND OCCURS

< SYMPTOM DIAGNOSIS >

[ABLS/ABS]

## PEDAL VIBRATION OR ABS OPERATION SOUND OCCURS

### Diagnosis Procedure

INFOID:000000001601131

#### **CAUTION:**

Under the following conditions, ABS is activated and vibration is felt when brake pedal is lightly depressed. However, this is normal.

- When shifting gears
- When driving on slippery road
- During cornering at high speed
- When passing over bumps or grooves [at approximately 50 mm (1.97 in) or more]
- When pulling away just after starting engine [at approximately 10 km/h (6 MPH) or higher]

#### 1. SYMPTOM CHECK 1

Check that there are pedal vibrations when the engine is started.

Do vibrations occur?

YES >> GO TO 2

NO >> Inspect the brake pedal.

#### 2. SYMPTOM CHECK 2

Check that there are ABS operation noises when the engine is started.

Do the operation noises occur?

YES >> GO TO 3

NO >> Perform self -diagnosis. Refer to [BRC-78, "CONSULT-III Function \(ABS\)"](#).

#### 3. SYMPTOM CHECK 3

Check symptoms when electrical component (headlamps, etc.) switches are operated.

Do symptoms occur?

YES >> Check if there is a radio, antenna, antenna lead wire, or wiring close to the control unit. If there is, move it farther away.

NO >> Normal

A  
B  
C  
D  
E  
F  
G  
H  
I  
J  
K  
L  
M  
N  
O  
P

BRC

## NORMAL OPERATING CONDITION

< SYMPTOM DIAGNOSIS >

[ABLS/ABS]

### NORMAL OPERATING CONDITION

#### Description

INFOID:000000001601133

Symptom	Result
Slight vibrations are felt on the brake pedal and the operation noises occur, when ABS is activated.	This is a normal condition due to the ABLS or ABS activation.
Stopping distance is longer than that of vehicles without ABS when the vehicle drives on rough, gravel, or snow-covered (fresh, deep snow) roads.	
The brake pedal vibrates and motor operation noises occur from the engine room, after the engine starts and just after the vehicle starts.	This is normal, and it is caused by the ABS operation check.

PRECAUTION

PRECAUTIONS

Precaution for Supplemental Restraint System (SRS) "AIR BAG" and "SEAT BELT PRE-TENSIONER"

INFOID:000000001601134

The Supplemental Restraint System such as "AIR BAG" and "SEAT BELT PRE-TENSIONER", used along with a front seat belt, helps to reduce the risk or severity of injury to the driver and front passenger for certain types of collision. This system includes seat belt switch inputs and dual stage front air bag modules. The SRS system uses the seat belt switches to determine the front air bag deployment, and may only deploy one front air bag, depending on the severity of a collision and whether the front occupants are belted or unbelted. Information necessary to service the system safely is included in the SR and SB section of this Service Manual.

**WARNING:**

- To avoid rendering the SRS inoperative, which could increase the risk of personal injury or death in the event of a collision which would result in air bag inflation, all maintenance must be performed by an authorized NISSAN/INFINITI dealer.
- Improper maintenance, including incorrect removal and installation of the SRS, can lead to personal injury caused by unintentional activation of the system. For removal of Spiral Cable and Air Bag Module, see the SR section.
- Do not use electrical test equipment on any circuit related to the SRS unless instructed to in this Service Manual. SRS wiring harnesses can be identified by yellow and/or orange harnesses or harness connectors.

Precaution for Brake System

INFOID:000000001601135

**CAUTION:**

- Always use recommended brake fluid. Refer to [MA-10, "Fluids and Lubricants"](#).
- Never reuse drained brake fluid.
- Be careful not to splash brake fluid on painted areas; it may cause paint damage. If brake fluid is splashed on painted areas, wash it away with water immediately.
- To clean or wash all parts of master cylinder and disc brake caliper, use clean brake fluid.
- Never use mineral oils such as gasoline or kerosene. They will ruin rubber parts of the hydraulic system.
- Use flare nut wrench when removing and installing brake tube.
- If a brake fluid leak is found, the part must be disassembled without fail. Then it has to be replaced with a new one if a defect exists.
- Turn the ignition switch OFF and remove the connector of the ABS actuator and electric unit (control unit) or the battery terminal before performing the work.
- Always torque brake lines when installing.
- Burnish the brake contact surfaces after refinishing or replacing rotors, after replacing pads, or if a soft pedal occurs at very low mileage.

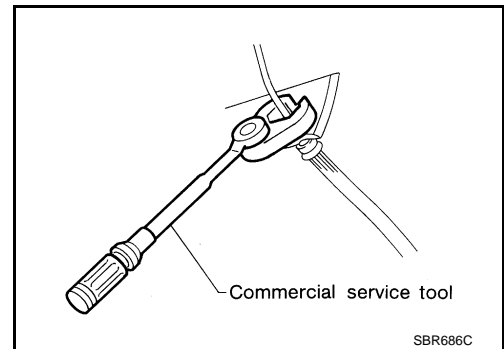

SBR686C

Refer to [BR-35, "Brake Burnishing Procedure"](#) (front disc brake) or [BR-40, "Removal and Installation of Brake Pad"](#) (rear disc brake).

**WARNING:**

- Clean brake pads and shoes with a waste cloth, then wipe with a dust collector.

Precaution for Brake Control

INFOID:000000001601136

- During ABS operation, the brake pedal may vibrate lightly and a mechanical noise may be heard. This is normal.
- Just after starting vehicle, the brake pedal may vibrate or a motor operating noise may be heard from engine compartment. This is a normal status of operation check.
- Stopping distance may be longer than that of vehicles without ABS when vehicle drives on rough, gravel, or snow-covered (fresh, deep snow) roads.

A  
B  
C  
D  
E  
BRC  
G  
H  
I  
J  
K  
L  
M  
N  
O  
P

# PRECAUTIONS

[ABLS/ABS]

## < PRECAUTION >

- When an error is indicated by ABS or another warning lamp, collect all necessary information from customer (what symptoms are present under what conditions) and check for simple causes before starting diagnosis. Besides electrical system inspection, check booster operation, brake fluid level, and fluid leaks.
- If incorrect tire sizes or types are installed on the vehicle or brake pads are not Genuine NISSAN parts, stopping distance or steering stability may deteriorate.
- If there is a radio, antenna or related wiring near control module, ABS function may have a malfunction or error.
- If aftermarket parts (car stereo, CD player, etc.) have been installed, check for incidents such as harness pinches, open circuits or improper wiring.

## Precaution for CAN System

INFOID:000000001601137

- Do not apply voltage of 7.0V or higher to terminal to be measured.
- Maximum open terminal voltage of tester in use must be less than 7.0V.
- Before checking harnesses, turn ignition switch OFF and disconnect battery negative cable.
- Area to be repaired must be soldered and wrapped with tape. Make sure that fraying of twisted wire is within 110 mm (4.33 in).

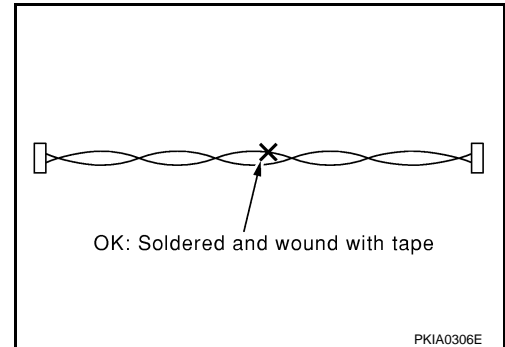

- Do not make a bypass connection to repaired area. (If the circuit is bypassed, characteristics of twisted wire will be lost.)

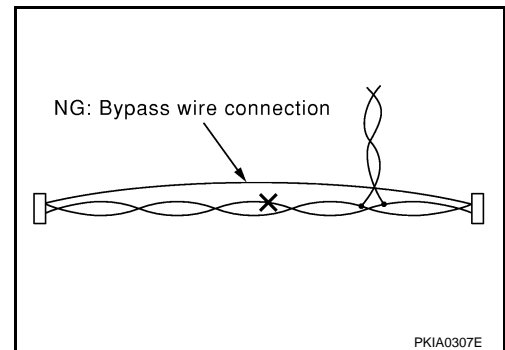

# PREPARATION

< PREPARATION >

[ABLS/ABS]

## PREPARATION

### PREPARATION

#### Special Service Tool

INFOID:000000001601798

The actual shapes of Kent-Moore tools may differ from those of special service tools illustrated here.

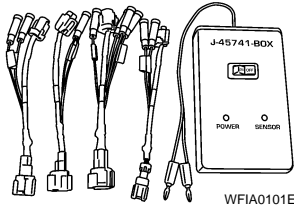
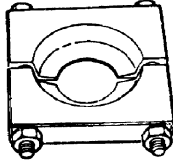
Tool number (Kent-Moore No.) Tool name	Description
<p>— (J-45741) ABS active wheel sensor tester</p>  <p>WFIA0101E</p>	<p>Checking operation of ABS active wheel sensors</p>
<p>ST30031000 ( — ) Bearing splitter</p>  <p>ZZA0700D</p>	<p>Removing axle shaft bearing</p>

#### Commercial Service Tool

INFOID:000000001601799

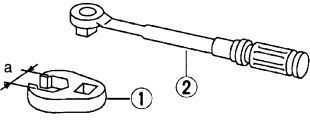
Tool name	Description
<p>1. Flare nut crowfoot 2. Torque wrench</p>  <p>S-NT360</p>	<p>Removing and installing brake piping a: 10mm (0.39 in)/12mm (0.47 in)</p>

# WHEEL SENSORS

< REMOVAL AND INSTALLATION >

[ABLS/ABS]

## REMOVAL AND INSTALLATION

### WHEEL SENSORS

#### Removal and Installation

INFOID:000000001601800

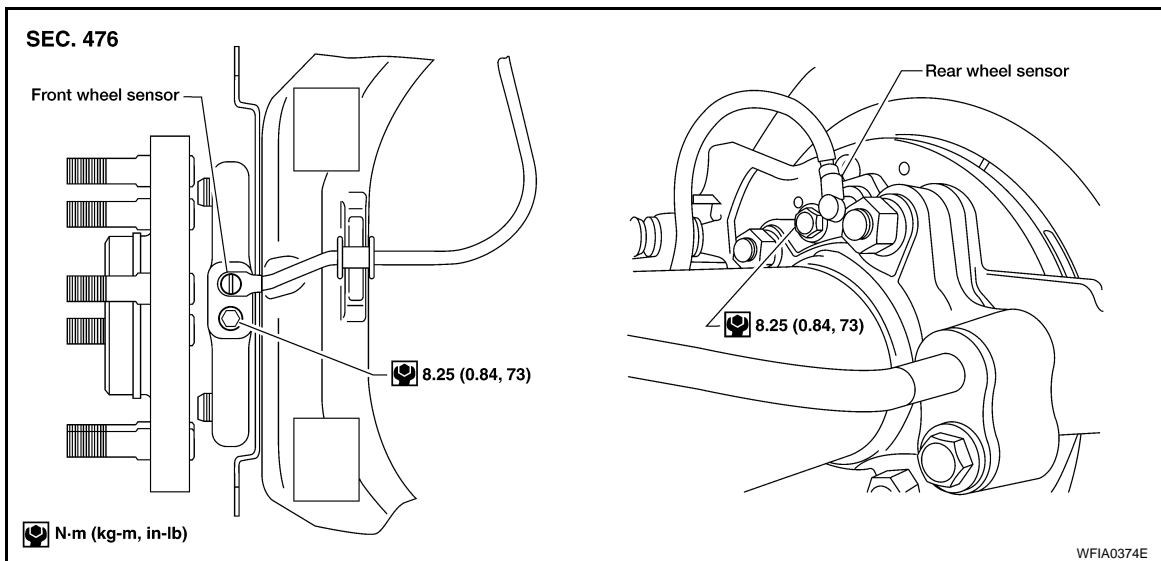

#### REMOVAL

1. Remove wheel sensor bolt.
  - When removing the front wheel sensor, first remove the disc rotor to gain access to the front wheel sensor bolt. Refer to [BR-34, "Removal and Installation of Brake Caliper and Disc Rotor"](#).
2. Pull out the sensor, being careful to turn it as little as possible.

**CAUTION:**

  - Be careful not to damage sensor edge and sensor rotor teeth.
  - Do not pull on the sensor harness.
3. Disconnect wheel sensor harness electrical connector, then remove harness from mounts.

#### INSTALLATION

Installation is in the reverse order of removal. Tighten wheel sensor bolt to specification.

**CAUTION:**

Installation should be performed while paying attention to the following:

- Inspect wheel sensor O-ring, replace sensor assembly if damaged.
- Clean wheel sensor hole and mounting surface with brake cleaner and a lint-free shop rag. Be careful that dirt and debris do not enter the axle.
- Apply a coat of suitable grease to the wheel sensor O-ring and mounting hole. Refer to [MA-10, "Fluids and Lubricants"](#).

# SENSOR ROTOR

< REMOVAL AND INSTALLATION >

[ABLS/ABS]

## SENSOR ROTOR

### Removal and Installation

INFOID:000000001601801

#### FRONT

The wheel sensor rotors are built into the wheel hubs and are not removable. If damaged, replace wheel hub and bearing assembly. Refer to [FAX-6, "Removal and Installation"](#).

#### REAR

##### Removal

1. Remove axle shaft assembly. Refer to [RAX-8, "Removal and Installation"](#).

**NOTE:**

It is necessary to disassemble the rear axle to replace the sensor rotor.

2. Pull the sensor rotor off the axle shaft using Tool and a press.

**Tool number** : ST30031000 ( — )

##### Installation

1. Install new sensor rotor on axle shaft using a suitable length steel tube and a press. Make sure sensor rotor is fully seated.

**CAUTION:**

**Do not reuse the old sensor rotor.**

2. Install axle shaft assembly. Refer to [RAX-8, "Removal and Installation"](#).

**CAUTION:**

**Do not reuse the axle oil seal. The axle oil seal must be replaced every time the axle shaft assembly is removed from the axle shaft housing.**

A  
B  
C  
D  
E  
BRC  
G  
H  
I  
J  
K  
L  
M  
N  
O  
P

# ACTUATOR AND ELECTRIC UNIT (ASSEMBLY)

< REMOVAL AND INSTALLATION >

[ABLS/ABS]

## ACTUATOR AND ELECTRIC UNIT (ASSEMBLY)

### Removal and Installation

INFOID:000000001601802

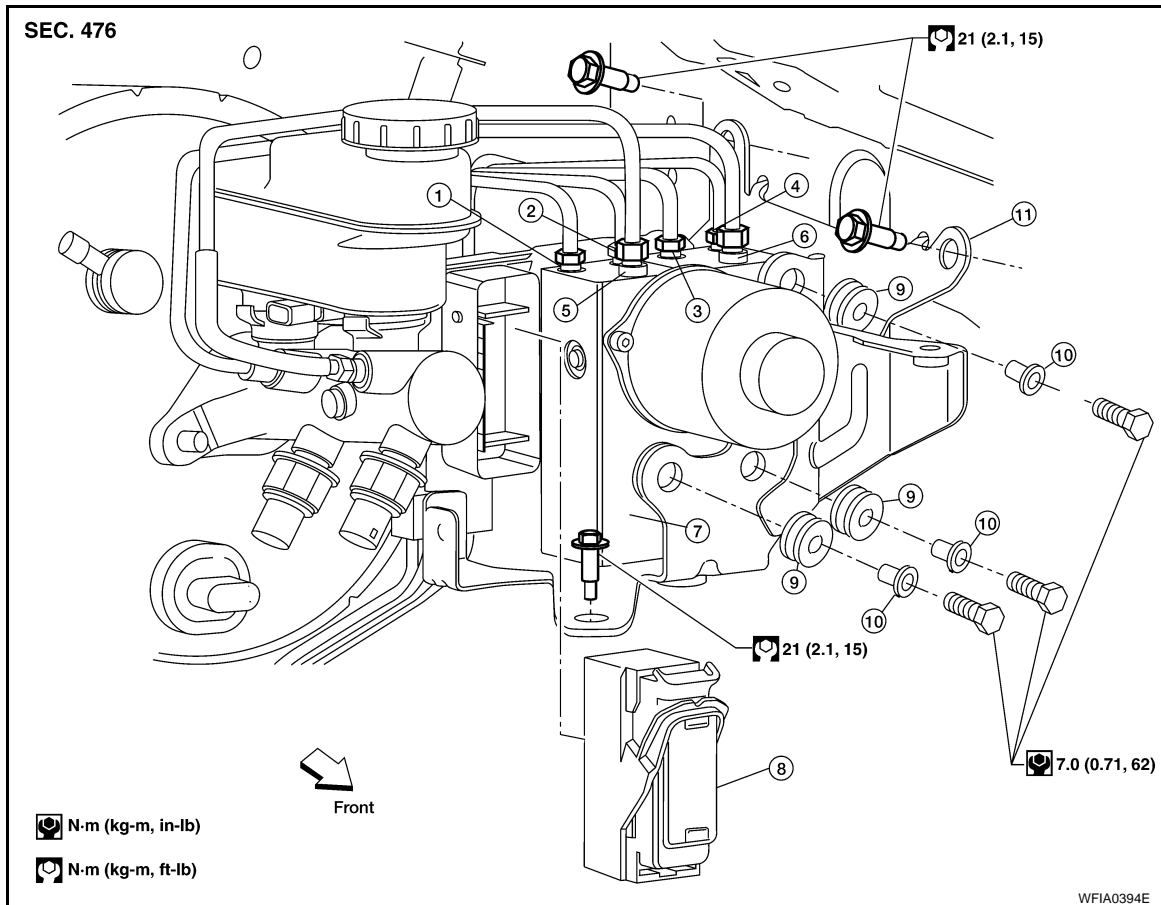

- |  |  |   |
|--|--|---|
| 1. Brake tube to rear left cylinder body         | 2. Brake tube to rear right cylinder body  | 3. Brake tube to front left cylinder body |
| 4. Brake tube to front right cylinder body       | 5. From the master cylinder secondary side | 6. From the master cylinder primary side  |
| 7. ABS actuator and electric unit (control unit) | 8. Harness connector                       | 9. Grommet                                |
| 10. Collar                                       | 11. Bracket                                |   |

### REMOVAL

1. Disconnect the battery negative terminal.
2. Remove the cowl top extension. Refer to [EXT-19, "Removal and Installation"](#).
3. Drain the brake fluid. Refer to [BR-16, "Drain and Refill"](#).
4. Disconnect the actuator harness connector from the ABS actuator and electric unit (control unit).

#### CAUTION:

- To remove the brake tubes, use a flare nut crowfoot and torque wrench to prevent the flare nuts and brake tubes from being damaged.
- Be careful not to splash brake fluid on painted areas; it may cause paint damage. If brake fluid is splashed on painted areas, wash it away with water immediately.

5. Disconnect the brake tubes.
6. Remove the three bolts and remove the ABS actuator and electric unit (control unit).

### INSTALLATION

Installation is in the reverse order of removal.

#### NOTE:



# ACTUATOR AND ELECTRIC UNIT (ASSEMBLY)

[ABLS/ABS]

## < REMOVAL AND INSTALLATION >

To install, use a flare nut crowfoot and torque wrench. Tighten brake tubes to specification when installing. Refer to [BR-12. "Hydraulic Circuit"](#).

- After installation of the ABS actuator and electric unit (control unit), refill the brake system with new brake fluid. Refer to [MA-10. "Fluids and Lubricants"](#). Then bleed the air from the system. Refer to [BR-16. "Bleeding Brake System"](#).

**CAUTION:**

**Never reuse drained brake fluid.**

A  
B  
C  
D  
E  
G  
H  
I  
J  
K  
L  
M  
N  
O  
P

**BRC**

## BASIC INSPECTION

### DIAGNOSIS AND REPAIR WORKFLOW

#### Work Flow

INFOID:000000001537121

#### PRECAUTIONS FOR DIAGNOSIS

If steering angle sensor, steering system parts, suspension system parts, ABS actuator and electric unit (control unit) or tires have been replaced, or if wheel alignment has been adjusted, be sure to adjust neutral position of steering angle sensor before driving. Refer to [BRC-150, "ADJUSTMENT OF STEERING ANGLE SENSOR NEUTRAL POSITION : Description"](#).

# DIAGNOSIS AND REPAIR WORKFLOW

< BASIC INSPECTION >

[VDC/TCS/ABS]

## OVERALL SEQUENCE

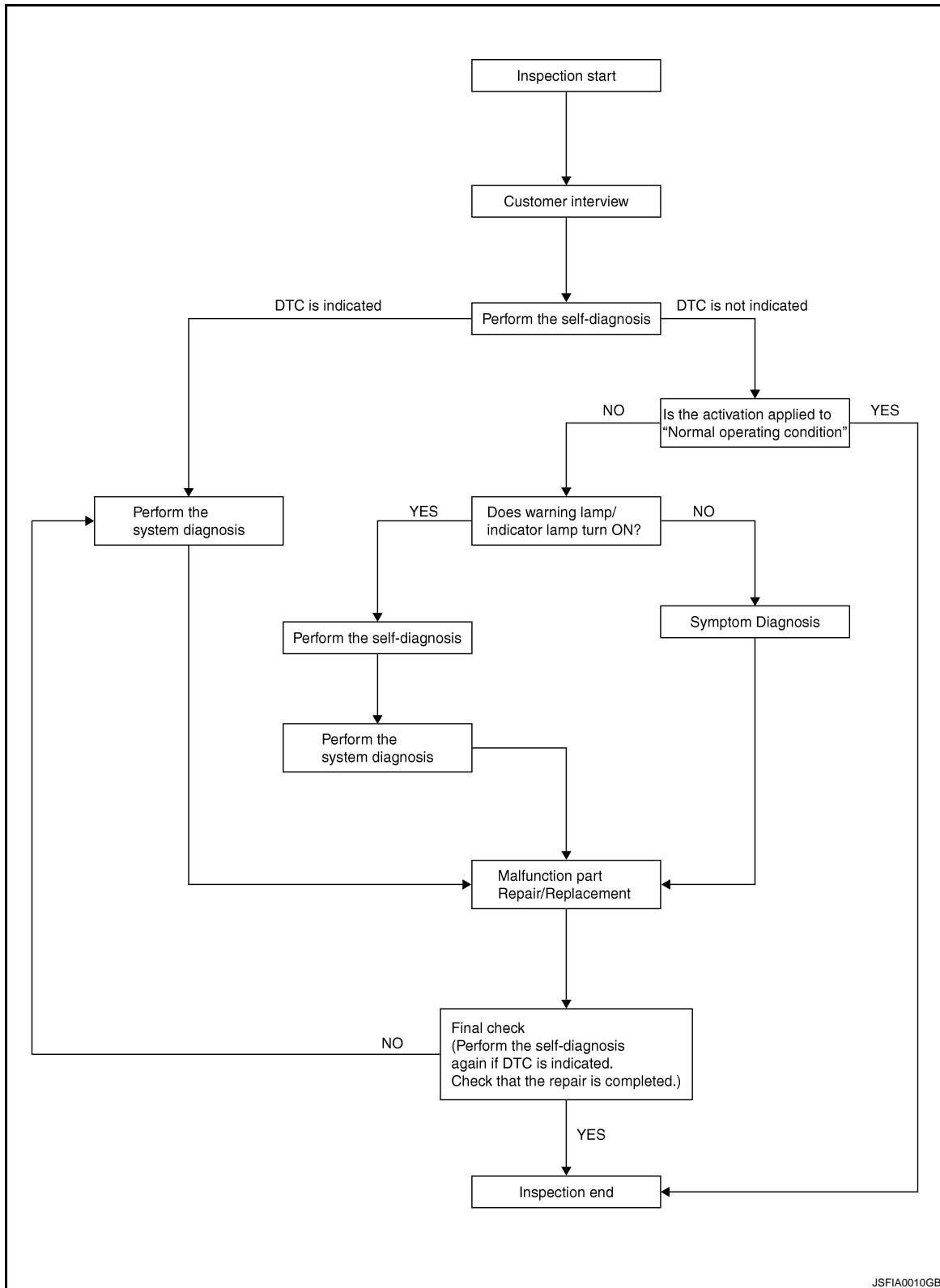

### DETAILED FLOW

#### 1. COLLECT THE INFORMATION FROM THE CUSTOMER

Get the detailed information from the customer about the symptom (the condition and the environment when the incident/malfunction occurred) using the diagnosis worksheet. Refer to [BRC-149, "Diagnostic Work Sheet"](#).

# DIAGNOSIS AND REPAIR WORKFLOW

[VDC/TCS/ABS]

< BASIC INSPECTION >

---

>> GO TO 2

## 2. PERFORM THE SELF-DIAGNOSIS

---

Check the DTC display with the self-diagnosis function. Refer to [BRC-165, "CONSULT-III Function \(ABS\)"](#).

Is there any DTC displayed?

YES >> GO TO 3

NO >> GO TO 4

## 3. PERFORM THE SYSTEM DIAGNOSIS

---

Perform the diagnosis applicable to the displayed DTC. Refer to [BRC-239, "DTC No. Index"](#).

>> GO TO 7

## 4. CHECK THE SYMPTOM THAT IS NOT CONSIDERED A SYSTEM MALFUNCTION

---

Check that the symptom is a normal operation that is not considered a system malfunction. Refer to [BRC-248, "Description"](#).

Is the symptom a normal operation?

YES >> INSPECTION END

NO >> GO TO 5

## 5. CHECK THE WARNING LAMP AND INDICATOR LAMP FOR ILLUMINATION

---

Check that the warning lamp and indicator lamp illuminate.

- ABS warning lamp: Refer to [BRC-222, "Description"](#).
- Brake warning lamp: Refer to [BRC-223, "Description"](#).
- VDC OFF indicator lamp: Refer to [BRC-224, "Description"](#).
- SLIP indicator lamp: Refer to [BRC-225, "Description"](#).

Is ON/OFF timing normal?

YES >> GO TO 6

NO >> GO TO 2

## 6. PERFORM THE DIAGNOSIS BY SYMPTOM

---

Perform the diagnosis applicable to the symptom.

>> GO TO 7

## 7. REPAIR OR REPLACE THE MALFUNCTIONING PARTS

---

Repair or replace the specified malfunctioning parts.

>> GO TO 8

## 8. FINAL CHECK

---

Perform the self-diagnosis again, and check that the malfunction is repaired completely. After checking, erase the self-diagnosis memory. Refer to [BRC-165, "CONSULT-III Function \(ABS\)"](#).

Is no other DTC present and the repair completed?

YES >> INSPECTION END

NO >> GO TO 3

# DIAGNOSIS AND REPAIR WORKFLOW

< BASIC INSPECTION >

[VDC/TCS/ABS]

## Diagnostic Work Sheet

INFOID:000000001537122

Customer name MR/MS	Model & Year	VIN	
Engine #	Trans.	Mileage	
Incident Date	Manuf. Date	In Service Date	
Symptoms	<input type="checkbox"/> Noise and vibration (from engine compartment)	<input type="checkbox"/> Warning / Indicator activate	<input type="checkbox"/> Firm pedal operation Large stroke pedal operation
	<input type="checkbox"/> Noise and vibration (from axle)	<input type="checkbox"/> TCS does not work (Rear wheels slip when accelerating)	<input type="checkbox"/> ABS does not work (Wheels lock when braking)
Engine conditions	<input type="checkbox"/> When starting <input type="checkbox"/> After starting		
Road conditions	<input type="checkbox"/> Low friction road ( <input type="checkbox"/> Snow <input type="checkbox"/> Gravel <input type="checkbox"/> Other ) <input type="checkbox"/> Bumps / potholes		
Driving conditions	<input type="checkbox"/> Full-acceleration <input type="checkbox"/> High speed cornering <input type="checkbox"/> Vehicle speed: Greater than 10 km/h (6 MPH) <input type="checkbox"/> Vehicle speed: 10 km/h (6 MPH) or less <input type="checkbox"/> Vehicle is stopped		
Applying brake conditions	<input type="checkbox"/> Suddenly <input type="checkbox"/> Gradually		
Other conditions	<input type="checkbox"/> Operation of electrical equipment <input type="checkbox"/> Shift change <input type="checkbox"/> Other descriptions		

SFIA3265E

A  
B  
C  
D  
E  
**BRC**  
G  
H  
I  
J  
K  
L  
M  
N  
O  
P

## INSPECTION AND ADJUSTMENT

### ADDITIONAL SERVICE WHEN REPLACING CONTROL UNIT

#### ADDITIONAL SERVICE WHEN REPLACING CONTROL UNIT : Description

INFOID:000000001537123

After replacing the ABS actuator and electric unit (control unit), perform the following procedures:

- Neutral position adjustment for the steering angle sensor
- Calibration of the decel G sensor

#### ADDITIONAL SERVICE WHEN REPLACING CONTROL UNIT : Special Repair Requirement

INFOID:000000001537124

#### 1. PERFORM THE NEUTRAL POSITION ADJUSTMENT FOR THE STEERING ANGLE SENSOR

Perform the neutral position adjustment for the steering angle sensor.

>> Refer to [BRC-150, "ADJUSTMENT OF STEERING ANGLE SENSOR NEUTRAL POSITION : Special Repair Requirement"](#), GO TO 2

#### 2. PERFORM CALIBRATION OF THE DECEL G SENSOR

Perform calibration of the decel G sensor.

>> Refer to [BRC-151, "CALIBRATION OF DECEL G SENSOR : Special Repair Requirement"](#).

### ADJUSTMENT OF STEERING ANGLE SENSOR NEUTRAL POSITION

#### ADJUSTMENT OF STEERING ANGLE SENSOR NEUTRAL POSITION : Description

INFOID:000000001537125

Refer to the table below to determine if adjustment of steering angle sensor neutral position is required.

x: Required –: Not required

Situation	Adjustment of steering angle sensor neutral position
Removing/Installing ABS actuator and electric unit (control unit)	—
Replacing ABS actuator and electric unit (control unit)	x
Removing/Installing steering angle sensor	x
Replacing steering angle sensor	x
Removing/Installing steering components	x
Replacing steering components	x
Removing/Installing suspension components	x
Replacing suspension components	x
Change tires to new ones	—
Tire rotation	—
Adjusting wheel alignment	x

#### ADJUSTMENT OF STEERING ANGLE SENSOR NEUTRAL POSITION : Special Repair Requirement

INFOID:000000001537126

#### ADJUSTMENT OF STEERING ANGLE SENSOR NEUTRAL POSITION

**CAUTION:**

**To adjust neutral position of steering angle sensor, make sure to use CONSULT-III (Adjustment cannot be done without CONSULT-III)**

#### 1. ALIGN THE VEHICLE STATUS

Stop vehicle with front wheels in straight-ahead position.

# INSPECTION AND ADJUSTMENT

< BASIC INSPECTION >

[VDC/TCS/ABS]

>> GO TO 2

## 2. PERFORM THE NEUTRAL POSITION ADJUSTMENT FOR THE STEERING ANGLE SENSOR

1. On the CONSULT-III screen, touch "WORK SUPPORT" and "ST ANG SEN ADJUSTMENT" in order.
2. Touch "START".

**CAUTION:**

**Do not touch steering wheel while adjusting steering angle sensor.**

3. After approximately 10 seconds, touch "END".

**NOTE:**

After approximately 60 seconds, it ends automatically.

4. Turn ignition switch OFF, then turn it ON again.

**CAUTION:**

**Be sure to perform above operation.**

>> GO TO 3

## 3. CHECK DATA MONITOR

1. Run vehicle with front wheels in straight-ahead position, then stop.
2. Select "DATA MONITOR". Then make sure "STR ANGLE SIG" is within  $0 \pm 2.5^\circ$ .

Is the steering angle within the specified range?

YES >> GO TO 4

NO >> Perform the neutral position adjustment for the steering angle sensor again, GO TO 1

## 4. ERASE THE SELF-DIAGNOSIS MEMORY

Erase the self-diagnosis memory of the ABS actuator and electric unit (control unit) and ECM.

- ABS actuator and electric unit (control unit): Refer to [BRC-165, "CONSULT-III Function \(ABS\)"](#).
- ECM: Refer to [EC-67, "CONSULT-III Function \(ENGINE\)"](#).

Are the memories erased?

YES >> INSPECTION END

NO >> Check the items indicated by the self-diagnosis.

## CALIBRATION OF DECEL G SENSOR

### CALIBRATION OF DECEL G SENSOR : Description

INFOID:000000001537127

Refer to the table below to determine if calibration of the decel G sensor is required.

x: Required –: Not required

Situation	Calibration of decel G sensor
Removing/Installing ABS actuator and electric unit (control unit)	—
Replacing ABS actuator and electric unit (control unit)	x
Removing/Installing steering angle sensor	x
Replacing steering angle sensor	x
Removing/Installing steering components	x
Replacing steering components	x
Removing/Installing suspension components	x
Replacing suspension components	x
Change tires to new ones	—
Tire rotation	—
Adjusting wheel alignment	x

### CALIBRATION OF DECEL G SENSOR : Special Repair Requirement

INFOID:000000001537128

#### CALIBRATION OF DECEL G SENSOR

**CAUTION:**

**To calibrate the decel G sensor, make sure to use CONSULT-III (Calibration cannot be done without CONSULT-III)**

---

## 1. ALIGN THE VEHICLE STATUS

---

Stop vehicle with front wheels in straight-ahead position.

>> GO TO 2

## 2. PERFORM CALIBRATION OF DECEL G SENSOR

---

1. On the CONSULT-III screen, touch "WORK SUPPORT" and "DECEL G SEN CALIBRATION" in order.
2. Touch "START".
3. After approximately 10 seconds, touch "END".

**NOTE:**

After approximately 60 seconds, it ends automatically.

4. Turn ignition switch OFF, then turn it ON again.

**CAUTION:**

Be sure to perform above operation.

>> GO TO 3

## 3. CHECK DATA MONITOR

---

1. Run vehicle with front wheels in straight-ahead position, then stop.
2. Select "DATA MONITOR". Then make sure "DECEL G SEN" is within  $\pm$ .

Is the inspection result normal?

YES >> GO TO 4

NO >> Perform calibration of decel G sensor again, GO TO 1

## 4. ERASE THE SELF-DIAGNOSIS MEMORY

---

Erase the self-diagnosis memory of the ABS actuator and electric unit (control unit) and ECM.

- ABS actuator and electric unit (control unit): Refer to [BRC-165. "CONSULT-III Function \(ABS\)".](#)
- ECM: Refer to [EC-67. "CONSULT-III Function \(ENGINE\)".](#)

Are the memories erased?

YES >> INSPECTION END

NO >> Check the items indicated by the self-diagnosis.



# FUNCTION DIAGNOSIS

## VDC

### System Diagram

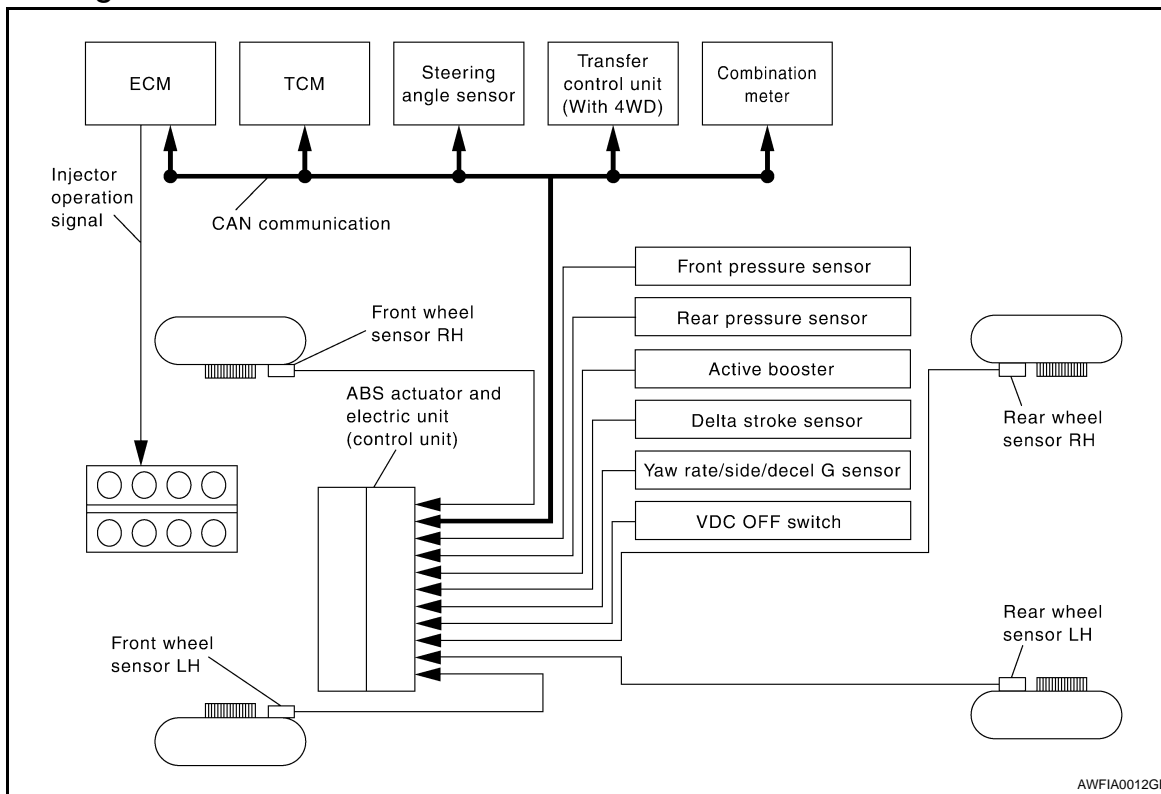

### System Description

INFOID:000000001537130

- Vehicle Dynamics Control system detects driver's steering operation amount and brake pedal travel from steering angle sensor and pressure sensors. Using information from yaw rate/side/decel G sensor and wheel sensor, VDC judges driving condition (conditions of under steer and over steer) to improve vehicle driving stability by controlling brake application to 4 wheels and engine output.
- During VDC operation, it informs driver of system operation by flashing SLIP indicator lamp.
- Electrical system diagnosis by CONSULT-III is available.

Component Parts Location

INFOID:000000001537131

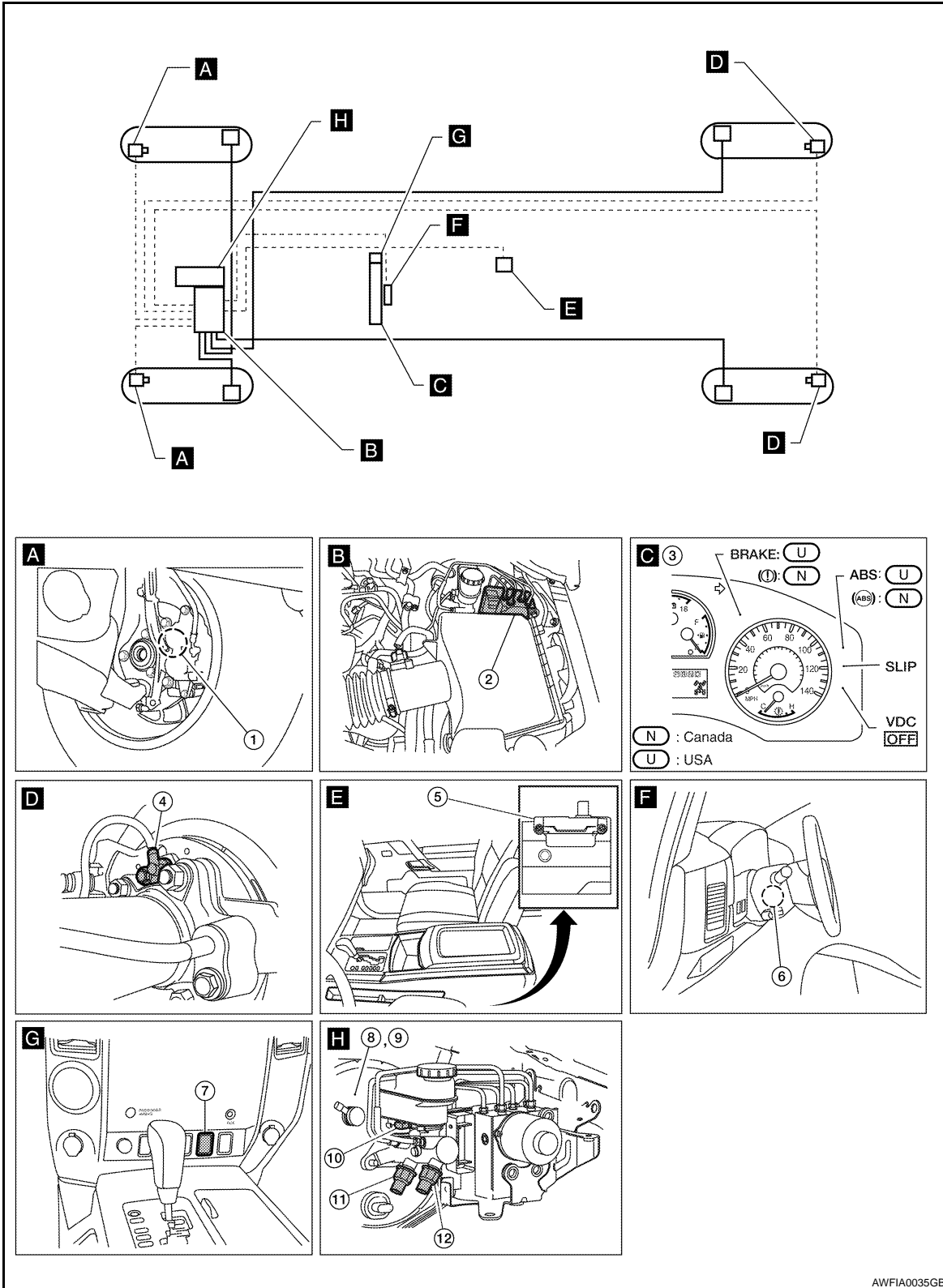

# VDC

[VDC/TCS/ABS]

## < FUNCTION DIAGNOSIS >

- |  |   |                               |
|--|---|-------------------------------|
| 1. Front wheel sensor<br>LH E18<br>RH E117 | 2. ABS actuator and electric unit (control unit) E125 | 3. Combination meter M24, M25 |
| 4. Rear wheel sensor<br>LH C11<br>RH C10   | 5. Yaw rate/side/decel G sensor M108                  | 6. Steering angle sensor M47  |
| 7. VDC OFF switch M148                     | 8. Active booster E49                                 | 9. Delta stroke sensor E114   |
| 10. Brake fluid level switch E21           | 11. Front pressure sensor E31                         | 12. Rear pressure sensor E32  |

A  
B  
C

## Component Description

INFOID:000000001537132

Component parts		Reference
ABS actuator and electric unit (control unit)	Pump	<a href="#">BRC-179, "Description"</a>
	Motor	
	Actuator relay	<a href="#">BRC-197, "Description"</a>
	Solenoid valve	<a href="#">BRC-189, "Description"</a>
	VDC switch-over valve (CV1, CV2, SV1, SV2)	<a href="#">BRC-211, "Description"</a>
Wheel sensor	<a href="#">BRC-170, "Description"</a>	
Yaw rate/side/decel G sensor	<a href="#">BRC-181, "Description"</a>	
Steering angle sensor	<a href="#">BRC-202, "Description"</a>	
VDC OFF switch	<a href="#">BRC-220, "Description"</a>	
ABS warning lamp	<a href="#">BRC-222, "Description"</a>	
Brake warning lamp	<a href="#">BRC-223, "Description"</a>	
VDC OFF indicator lamp	<a href="#">BRC-224, "Description"</a>	
SLIP indicator lamp	<a href="#">BRC-225, "Description"</a>	
Front pressure sensor	<a href="#">BRC-199, "Description"</a>	
Rear pressure sensor		
Active booster	<a href="#">BRC-214, "Description"</a>	
Delta stroke sensor	<a href="#">BRC-217, "Description"</a>	

BRC

D  
E  
G  
H  
I  
J  
K  
L  
M  
N  
O  
P

## TCS

## System Diagram

INFOID:000000001675419

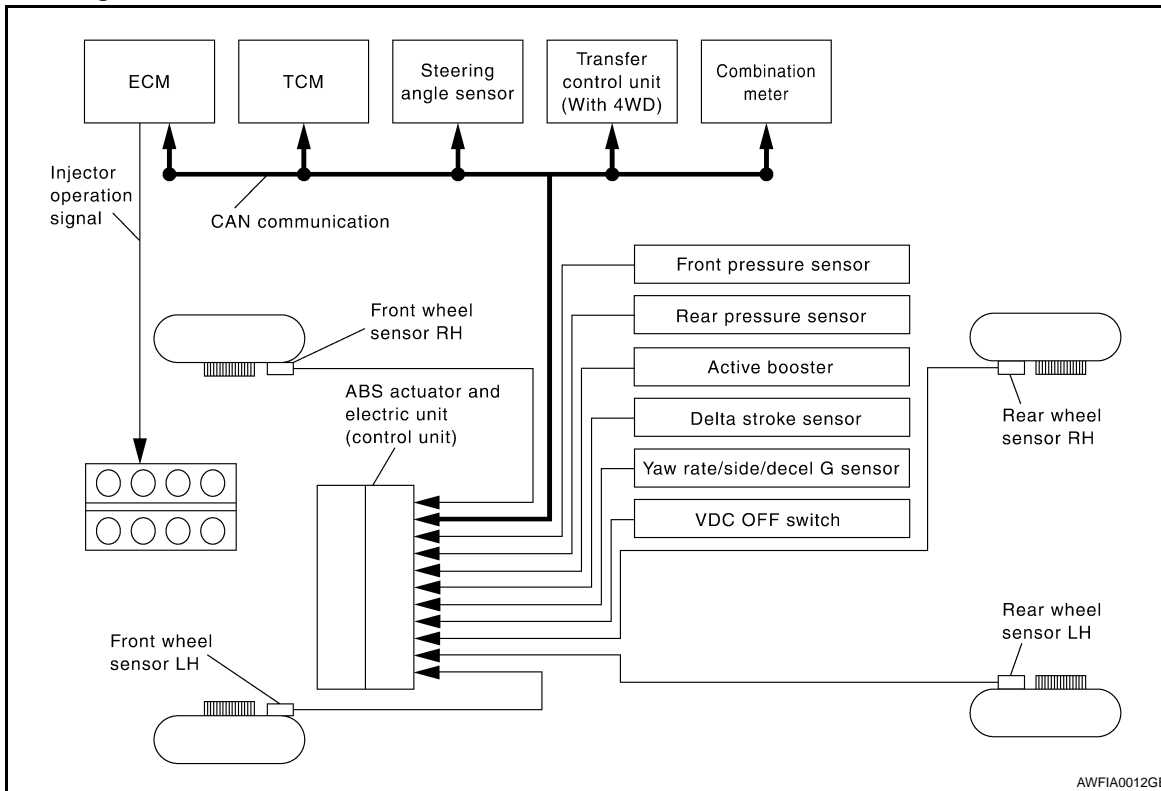

## System Description

INFOID:000000001537134

- Traction Control System is a function that electronically controls engine torque, brake fluid pressure and A/T gear position to ensure the optimum slippage ratio at drive wheels by computing wheel speed signals from 4 wheel sensors. When ABS actuator and electric unit (control unit) detects a spin at drive wheels (rear wheels), it compares wheel speed signals from all 4 wheels. At this time, LH and RH rear brake fluid pressure are controlled, while fuel being cut to engine and throttle valve being closed to reduce engine torque by the control unit. Further more, throttle position is continuously controlled to ensure the optimum engine torque at all times.
- During TCS operation, it informs driver of system operation by flashing SLIP indicator lamp.
- Electrical system diagnosis by CONSULT-III is available.

Component Parts Location

INFOID:000000001675420

A  
B  
C  
D  
E  
BRC  
G  
H  
I  
J  
K  
L  
M  
N  
O  
P

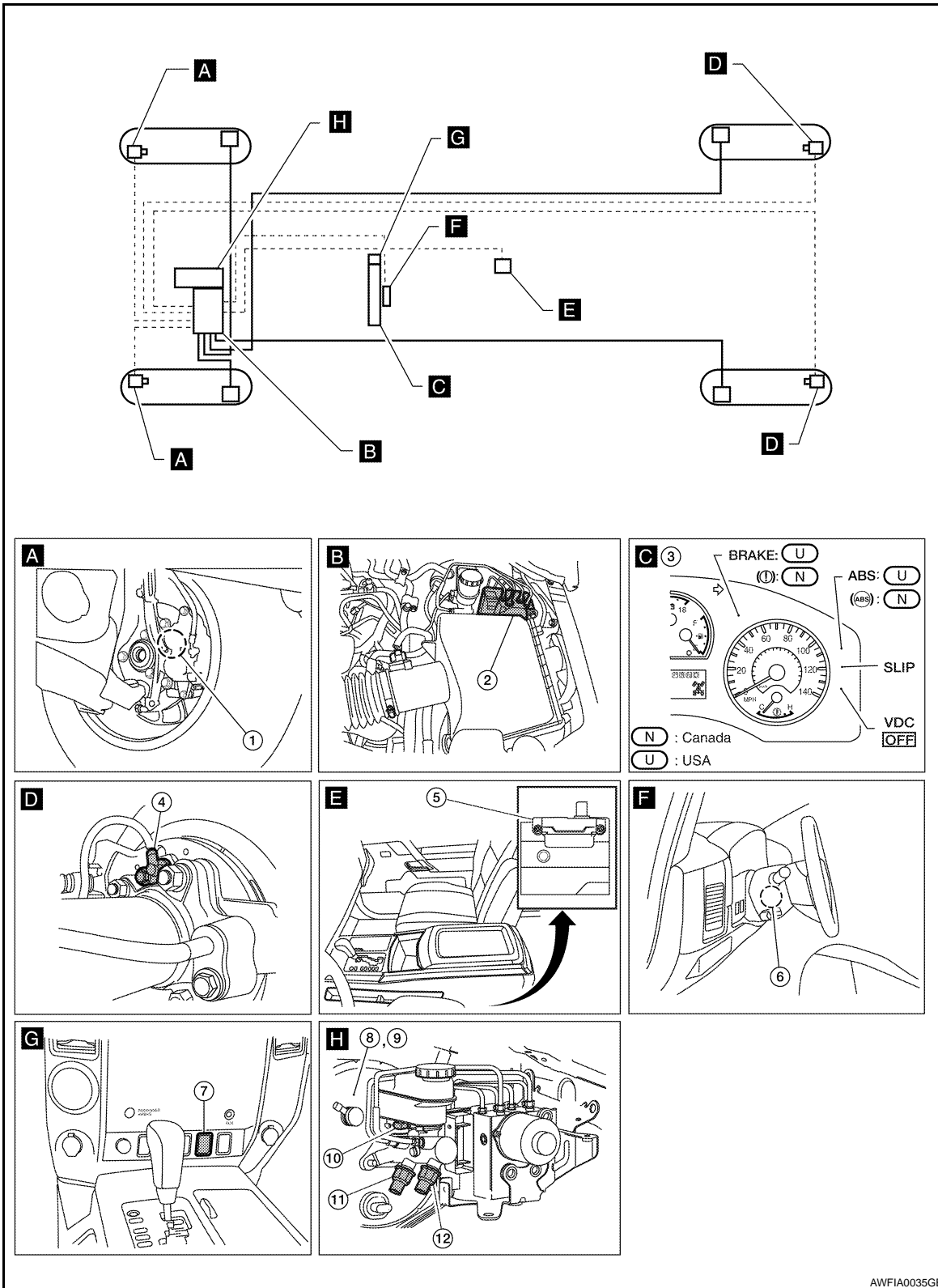

AWFIA0035GB

# TCS

< FUNCTION DIAGNOSIS >

[VDC/TCS/ABS]

- |  |   |                               |
|--|---|-------------------------------|
| 1. Front wheel sensor<br>LH E18<br>RH E117 | 2. ABS actuator and electric unit (control unit) E125 | 3. Combination meter M24, M25 |
| 4. Rear wheel sensor<br>LH C11<br>RH C10   | 5. Yaw rate/side/decel G sensor M108                  | 6. Steering angle sensor M47  |
| 7. VDC OFF switch M148                     | 8. Active booster E49                                 | 9. Delta stroke sensor E114   |
| 10. Brake fluid level switch E21           | 11. Front pressure sensor E31                         | 12. Rear pressure sensor E32  |

## Component Description

INFOID:000000001675421

Component parts		Reference
ABS actuator and electric unit (control unit)	Pump	<a href="#">BRC-179, "Description"</a>
	Motor	
	Actuator relay	<a href="#">BRC-197, "Description"</a>
	Solenoid valve	<a href="#">BRC-189, "Description"</a>
	VDC switch-over valve (CV1, CV2, SV1, SV2)	<a href="#">BRC-211, "Description"</a>
Wheel sensor		<a href="#">BRC-170, "Description"</a>
Yaw rate/side/decel G sensor		<a href="#">BRC-181, "Description"</a>
Steering angle sensor		<a href="#">BRC-202, "Description"</a>
VDC OFF switch		<a href="#">BRC-220, "Description"</a>
ABS warning lamp		<a href="#">BRC-222, "Description"</a>
Brake warning lamp		<a href="#">BRC-223, "Description"</a>
VDC OFF indicator lamp		<a href="#">BRC-224, "Description"</a>
SLIP indicator lamp		<a href="#">BRC-225, "Description"</a>
Front pressure sensor		<a href="#">BRC-199, "Description"</a>
Rear pressure sensor		
Active booster		<a href="#">BRC-214, "Description"</a>
Delta stroke sensor		<a href="#">BRC-217, "Description"</a>

ABS

System Diagram

INFOID:000000001537137

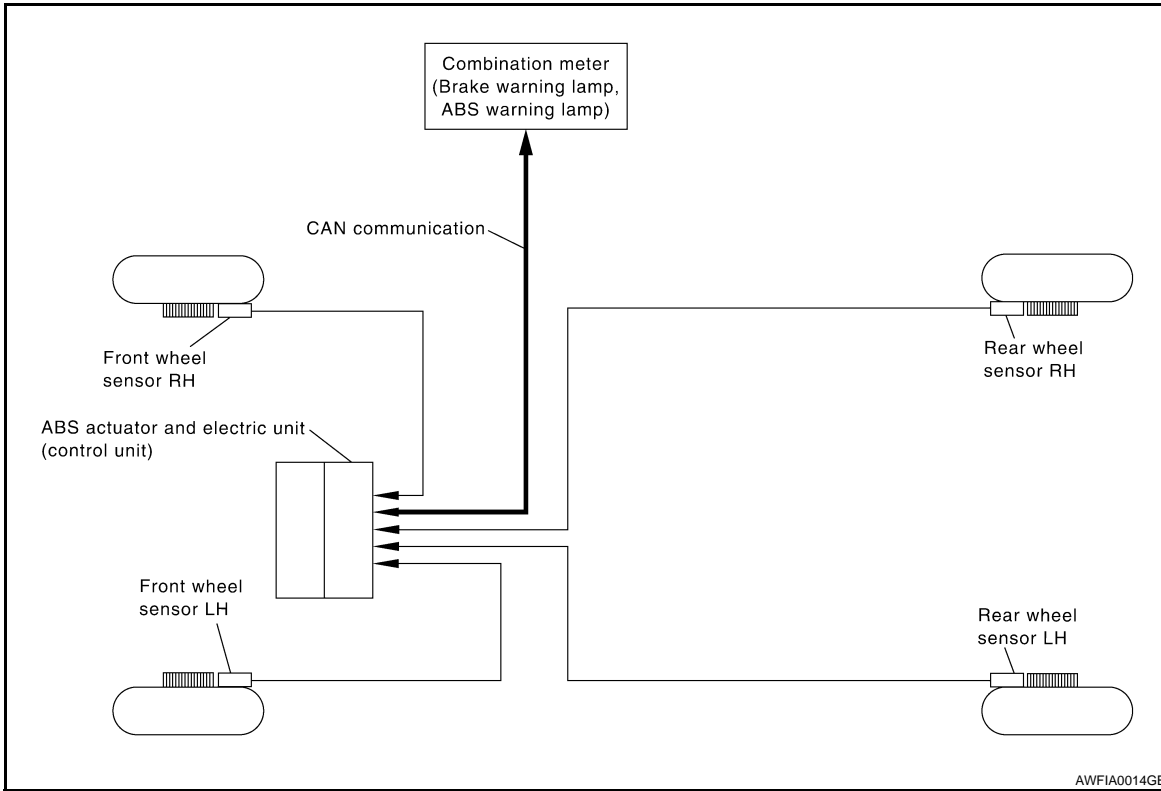

A  
B  
C  
D  
E  
BRC  
G  
H  
I  
J  
K  
L  
M  
N  
O  
P

System Description

INFOID:000000001537138

- Anti-Lock Braking System is a function that detects wheel revolution while braking, electronically controls braking force, and prevents wheel locking during sudden braking. It improves handling stability and maneuverability for avoiding obstacles.
- Electrical system diagnosis by CONSULT-III is available.

# ABS

< FUNCTION DIAGNOSIS >

[VDC/TCS/ABS]

## Component Parts Location

INFOID:000000001675422

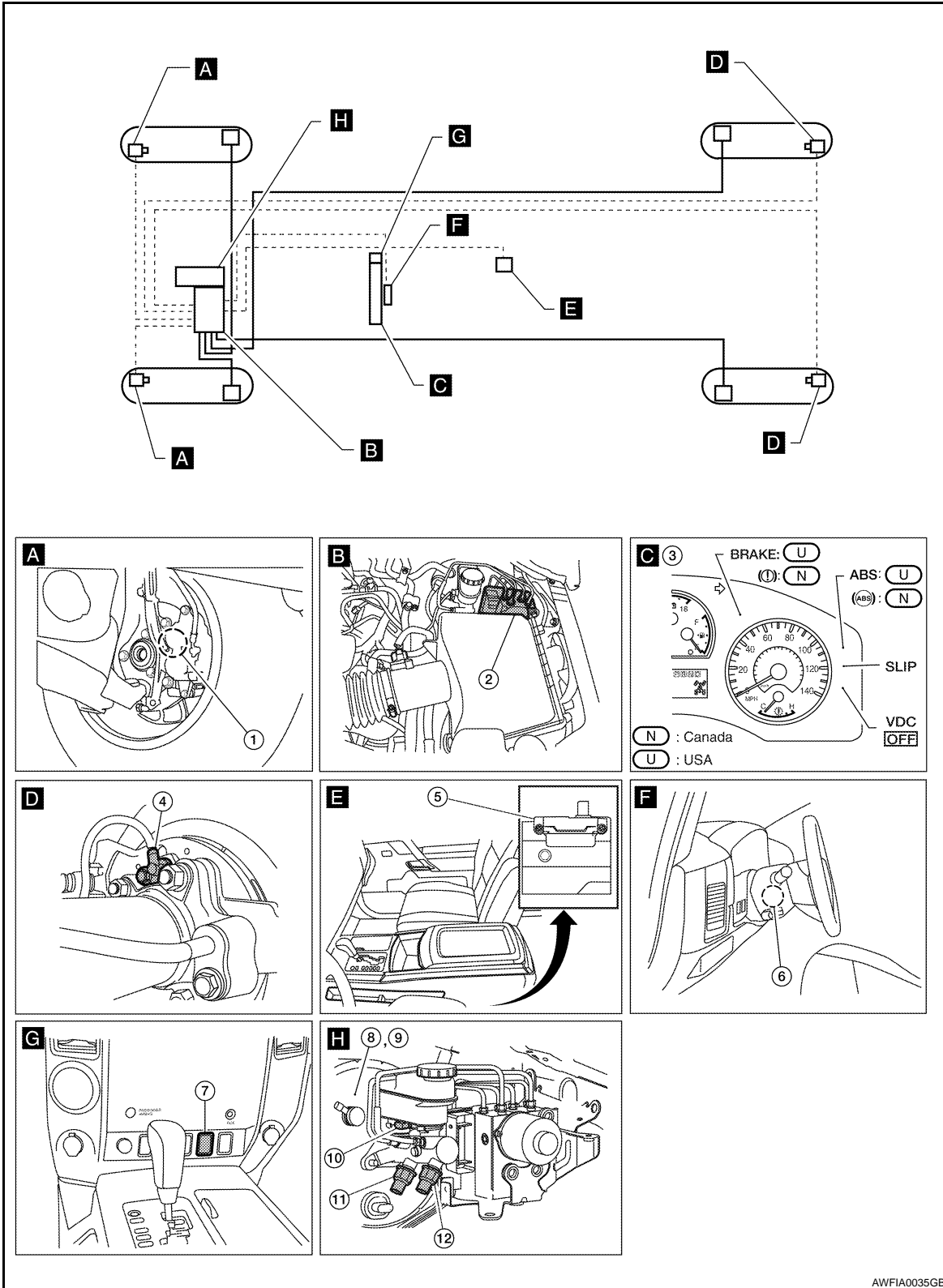



# ABS

< FUNCTION DIAGNOSIS >

[VDC/TCS/ABS]

- |  |   |                               |   |
|--|---|-------------------------------|---|
| 1. Front wheel sensor<br>LH E18<br>RH E117 | 2. ABS actuator and electric unit (control unit) E125 | 3. Combination meter M24, M25 | A |
| 4. Rear wheel sensor<br>LH C11<br>RH C10   | 5. Yaw rate/side/decel G sensor M108                  | 6. Steering angle sensor M47  | B |
| 7. VDC OFF switch M148                     | 8. Active booster E49                                 | 9. Delta stroke sensor E114   | C |
| 10. Brake fluid level switch E21           | 11. Front pressure sensor E31                         | 12. Rear pressure sensor E32  | C |

## Component Description

INFOID:000000001537140

Component parts	Reference	
ABS actuator and electric unit (control unit)	Pump	<a href="#">BRC-179, "Description"</a>
	Motor	
	Actuator relay	<a href="#">BRC-197, "Description"</a>
	Solenoid valve	<a href="#">BRC-189, "Description"</a>
Wheel sensor	<a href="#">BRC-170, "Description"</a>	
ABS warning lamp	<a href="#">BRC-222, "Description"</a>	
Brake warning lamp	<a href="#">BRC-223, "Description"</a>	

A  
B  
C  
D  
E  
BRC  
G  
H  
I  
J  
K  
L  
M  
N  
O  
P

## EBD

## System Diagram

INFOID:000000001675423

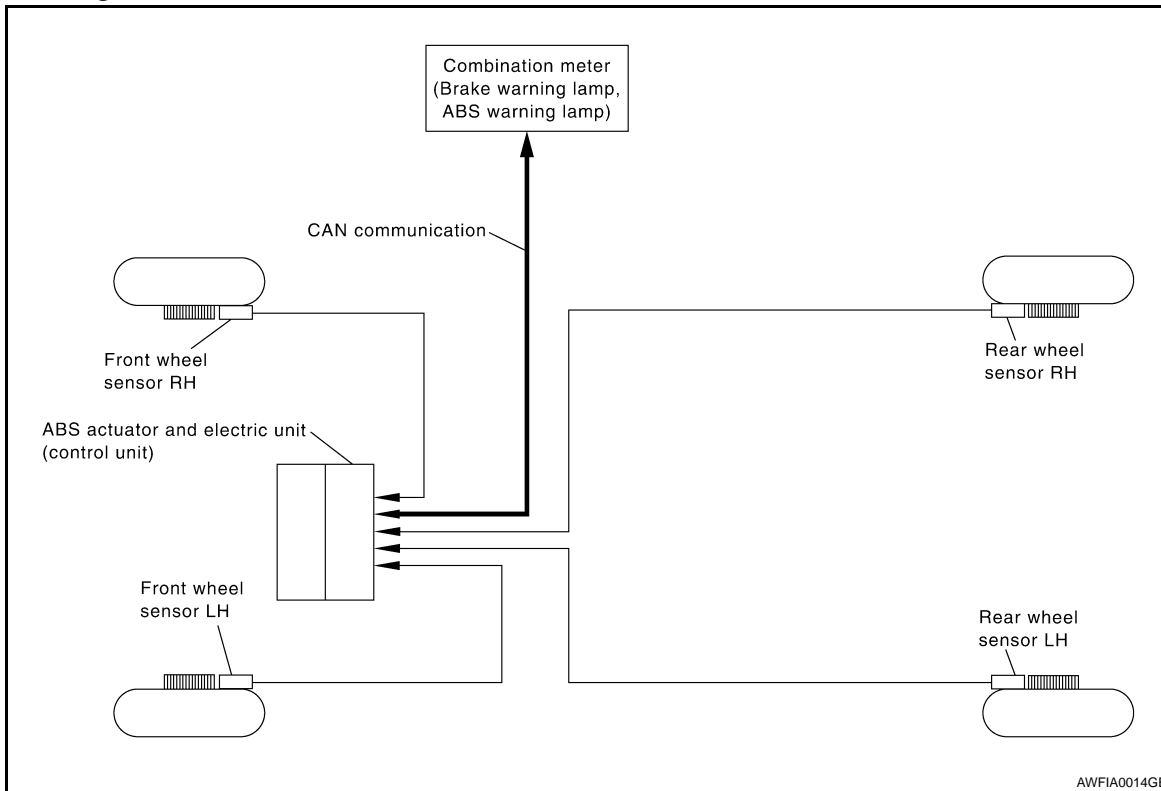

## System Description

INFOID:000000001537142

- Electric Brake force Distribution is a following function. ABS actuator and electric unit (control unit) detects subtle slippages between the front and rear wheels during braking. Then it electronically controls the rear braking force (brake fluid pressure) to reduce rear wheel slippage. Accordingly, it improves vehicle stability.
- Electrical system diagnosis by CONSULT-III is available.

A  
B  
C  
D  
E  
BRC  
G  
H  
I  
J  
K  
L  
M  
N  
O  
P

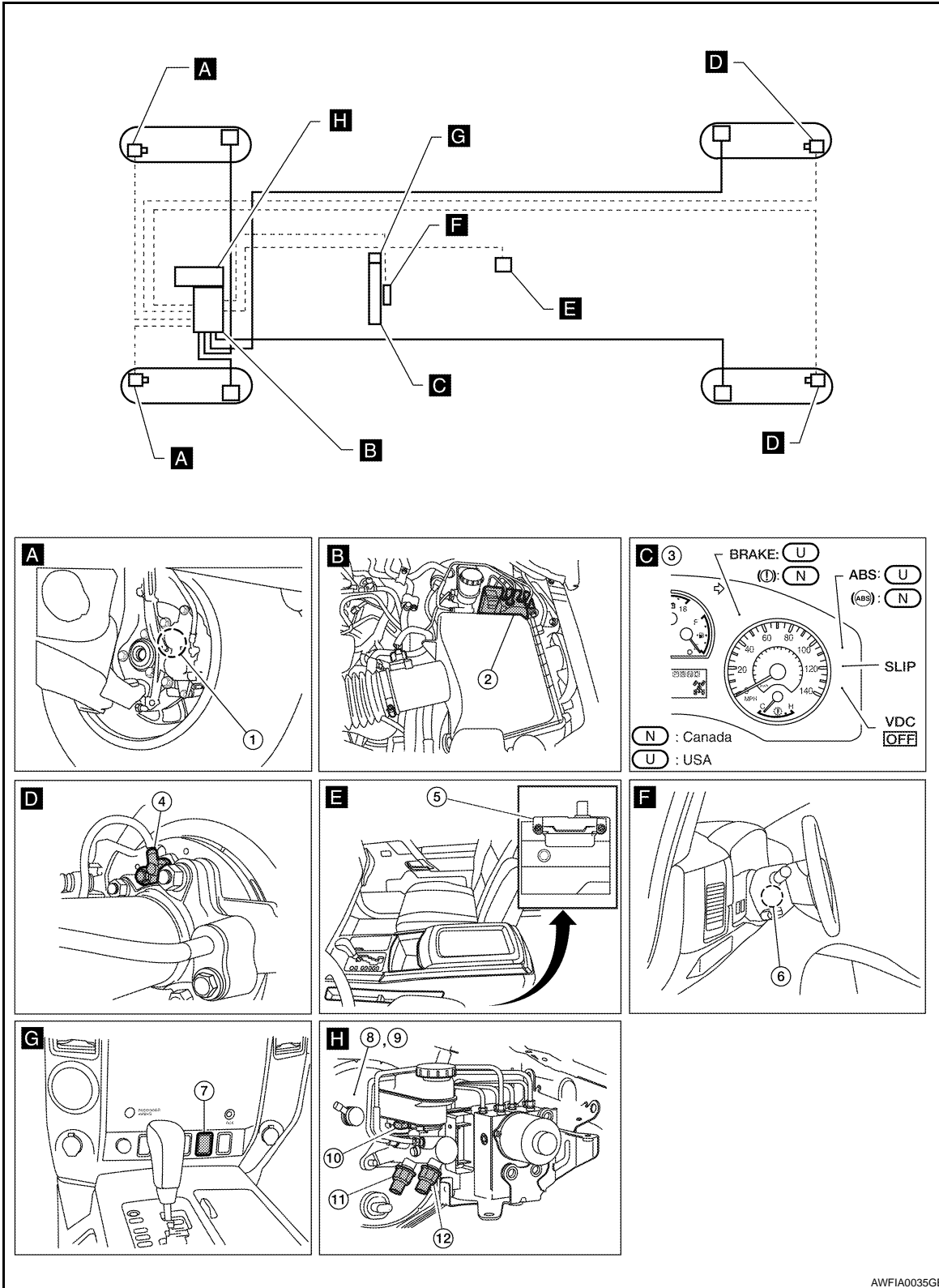

# EBD

< FUNCTION DIAGNOSIS >

[VDC/TCS/ABS]

- |  |   |                               |
|--|---|-------------------------------|
| 1. Front wheel sensor<br>LH E18<br>RH E117 | 2. ABS actuator and electric unit (control unit) E125 | 3. Combination meter M24, M25 |
| 4. Rear wheel sensor<br>LH C11<br>RH C10   | 5. Yaw rate/side/decel G sensor M108                  | 6. Steering angle sensor M47  |
| 7. VDC OFF switch M148                     | 8. Active booster E49                                 | 9. Delta stroke sensor E114   |
| 10. Brake fluid level switch E21           | 11. Front pressure sensor E31                         | 12. Rear pressure sensor E32  |

## Component Description

INFOID:000000001675425

Component parts		Reference
ABS actuator and electric unit (control unit)	Pump	<a href="#">BRC-179, "Description"</a>
	Motor	
	Actuator relay	<a href="#">BRC-197, "Description"</a>
	Solenoid valve	<a href="#">BRC-189, "Description"</a>
Wheel sensor		<a href="#">BRC-170, "Description"</a>
ABS warning lamp		<a href="#">BRC-222, "Description"</a>
Brake warning lamp		<a href="#">BRC-223, "Description"</a>

# DIAGNOSIS SYSTEM [ABS ACTUATOR AND ELECTRIC UNIT (CONTROL UNIT)]

< FUNCTION DIAGNOSIS >

[VDC/TCS/ABS]

## DIAGNOSIS SYSTEM [ABS ACTUATOR AND ELECTRIC UNIT (CONTROL UNIT)]

### CONSULT-III Function (ABS)

INFOID:000000001537145

#### FUNCTION

CONSULT-III can display each diagnostic item using the diagnostic test modes shown following.

Diagnostic test mode	Function
Work support	This mode enables a technician to adjust some devices faster and more accurately by following the indications on CONSULT-III.
Self-diagnostic results	Self-diagnostic results can be read and erased quickly.
Data monitor	Input/Output data in the ABS actuator and electric unit (control unit) can be read.
Active test	Diagnostic test mode is which CONSULT-III drives some actuators apart from the ABS actuator and electric unit (control unit) and also shifts some parameters in a specified range.
ECU part number	ABS actuator and electric unit (control unit) part number can be read.
CAN diagnostic support monitor	The results of transmit/receive diagnosis of CAN communication can be read.

#### SELF-DIAG RESULTS MODE

##### Operation Procedure

- Before performing the self-diagnosis, start engine and drive vehicle at 30 km/h (19 MPH) or more for approximately 1 minute.

##### How to Erase Self-diagnosis Results

- After erasing DTC memory, start engine and drive vehicle at 30 km/h (19 MPH) or more for approximately 1 minute as the final inspection, and make sure that the ABS warning lamp, VDC OFF indicator lamp, SLIP indicator lamp and brake warning lamp turn OFF.

**CAUTION:**

**If memory cannot be erased, perform applicable diagnosis.**

**NOTE:**

- When the wheel sensor malfunctions, after inspecting the wheel sensor system, the ABS warning lamp, VDC OFF indicator lamp, SLIP indicator lamp and brake warning lamp will not turn OFF even when the system is normal unless the vehicle is driving at approximately 30 km/h (19 MPH) or more for approximately 1 minute.
- Brake warning lamp will turn ON in case of parking brake operation (when switch is ON) or of brake fluid level switch operation (when brake fluid is insufficient).
- VDC OFF switch should not stay "ON" position.

##### Display Item List

Refer to [BRC-239, "DTC No. Index"](#).

#### DATA MONITOR MODE

##### Display Item List

Item (Unit)	Data monitor item selection			Remarks
	ECU INPUT SIGNALS	MAIN SIGNALS	SELECTION FROM MENU	
GEAR	×	×	×	Gear position judged by PNP switch signal is displayed.
FR RH SENSOR (km/h, MPH)	×	×	×	Wheel speed calculated by front RH wheel sensor signal is displayed.
FR LH SENSOR (km/h, MPH)	×	×	×	Wheel speed calculated by front LH wheel sensor signal is displayed.
RR RH SENSOR (km/h, MPH)	×	×	×	Wheel speed calculated by rear RH wheel sensor signal is displayed.

# DIAGNOSIS SYSTEM [ABS ACTUATOR AND ELECTRIC UNIT (CONTROL UNIT)]

< FUNCTION DIAGNOSIS >

[VDC/TCS/ABS]

Item (Unit)	Data monitor item selection			Remarks
	ECU INPUT SIGNALS	MAIN SIGNALS	SELECTION FROM MENU	
RR LH SENSOR (km/h, MPH)	×	×	×	Wheel speed calculated by rear LH wheel sensor signal is displayed.
BATTERY VOLT (V)	×	×	×	Voltage supplied to ABS actuator and electric unit (control unit) is displayed.
N POSI SIG	-	-	×	Shift position judged by PNP switch signal.
P POSI SIG	-	-	×	Shift position judged by PNP switch signal.
ACCEL POS SIG (%)	×	-	×	Throttle valve open/close status judged by CAN communication signal is displayed.
ENGINE SPEED (rpm)	×	×	×	Engine speed judged by CAN communication signal is displayed.
STR ANGLE SIG (deg)	×	-	×	Steering angle detected by steering angle sensor is displayed.
YAW RATE SEN (d/s)	×	×	×	Yaw rate detected by yaw rate sensor is displayed.
SIDE G-SENSOR (m/s <sup>2</sup> )	×	-	×	Transverse acceleration detected by side G-sensor is displayed.
DECEL G-SEN (G)	×	×	×	Longitudinal acceleration detected by decel G-sensor is displayed.
STOP LAMP SW (ON/OFF)	×	×	×	Stop lamp switch (ON/OFF) status is displayed.
OFF SW (ON/OFF)	×	×	×	VDC OFF switch (ON/OFF) status is displayed.
ABS WARN LAMP (ON/OFF)	-	×	×	ABS warning lamp (ON/OFF) status is displayed.
SLIP LAMP (ON/OFF)	-	×	×	SLIP indicator lamp (ON/OFF) status is displayed.
FR LH IN SOL (ON/OFF)	-	×	×	Front LH IN ABS solenoid (ON/OFF) status is displayed.
FR LH OUT SOL (ON/OFF)	-	×	×	Front LH OUT ABS solenoid (ON/OFF) status is displayed.
RR RH IN SOL (ON/OFF)	-	×	×	Rear RH IN ABS solenoid (ON/OFF) status is displayed.
RR RH OUT SOL (ON/OFF)	-	×	×	Rear RH OUT ABS solenoid (ON/OFF) status is displayed.
FR RH IN SOL (ON/OFF)	-	×	×	Front RH IN ABS solenoid (ON/OFF) status is displayed.
FR RH OUT SOL (ON/OFF)	-	×	×	Front RH OUT ABS solenoid (ON/OFF) status is displayed.
RR LH IN SOL (ON/OFF)	-	×	×	Rear LH IN ABS solenoid (ON/OFF) status is displayed.
RR LH OUT SOL (ON/OFF)	-	×	×	Rear LH OUT ABS solenoid (ON/OFF) status is displayed.
OFF LAMP (ON/OFF)	-	×	×	OFF Lamp (ON/OFF) status is displayed.
MOTOR RELAY (ON/OFF)	-	×	×	ABS motor relay signal (ON/OFF) status is displayed.

# DIAGNOSIS SYSTEM [ABS ACTUATOR AND ELECTRIC UNIT (CONTROL UNIT)]

< FUNCTION DIAGNOSIS >

[VDC/TCS/ABS]

Item (Unit)	Data monitor item selection			Remarks
	ECU INPUT SIGNALS	MAIN SIGNALS	SELECTION FROM MENU	
ACTUATOR RLY (ON/OFF)	-	×	×	ABS actuator relay signal (ON/OFF) status is displayed.
CV1 (ON/OFF)	-	-	×	Front side switch-over solenoid valve (cut valve) (ON/OFF) status is displayed.
CV2 (ON/OFF)	-	-	×	Rear side switch-over solenoid valve (cut-valve) (ON/OFF) status is displayed.
SV1 (ON/OFF)	-	-	×	Front side switch-over solenoid valve (suction valve) (ON/OFF) status is displayed.
SV2 (ON/OFF)	-	-	×	Rear side switch-over solenoid valve (suction valve) (ON/OFF) status is displayed.
VDC FAIL SIG (ON/OFF)	-	-	×	VDC fail signal (ON/OFF) status is displayed.
TCS FAIL SIG (ON/OFF)	-	-	×	TCS fail signal (ON/OFF) status is displayed.
ABS FAIL SIG (ON/OFF)	-	-	×	ABS fail signal (ON/OFF) status is displayed.
EBD FAIL SIG (ON/OFF)	-	-	×	EBD fail signal (ON/OFF) status is displayed.
FLUID LEV SW (ON/OFF)	×	-	×	Brake fluid level switch (ON/OFF) status is displayed.
EBD SIGNAL (ON/OFF)	-	-	×	EBD operation (ON/OFF) status is displayed.
ABS SIGNAL (ON/OFF)	-	-	×	ABS operation (ON/OFF) status is displayed.
TCS SIGNAL (ON/OFF)	-	-	×	TCS operation (ON/OFF) status is displayed.
VDC SIGNAL (ON/OFF)	-	-	×	VDC operation (ON/OFF) status is displayed.
EBD WARN LAMP	-	-	×	Brake warning lamp (ON/OFF) status is displayed.
SLCT LVR POSI	×	×	×	Shift position judged by PNP switch signal.
R POSI SIG	-	-	×	Shift position judged by PNP switch signal.
2WD/4WD	-	-	×	It recognizes on software whether it is 2WD and whether it is in 4WD state.
BST OPER SIG	-	-	×	Active booster operation (ON/OFF) status is displayed.
PRESS SENSOR	×	-	×	Brake pressure detected by pressure sensor is displayed.
CRANKING SIG	-	-	×	The input state of the key SW START position signal is displayed.
PRESS SEN 2	-	-	×	Brake pressure detected by pressure sensor is displayed.
DELTA S SEN	-	-	×	The amount of stroke sensor movements in the active booster detected by DELTA S SEN is displayed.

A  
B  
C  
D  
E  
BRC

G  
H  
I  
J  
K

L  
M

N  
O

P

# DIAGNOSIS SYSTEM [ABS ACTUATOR AND ELECTRIC UNIT (CONTROL UNIT)]

< FUNCTION DIAGNOSIS >

[VDC/TCS/ABS]

Item (Unit)	Data monitor item selection			Remarks
	ECU INPUT SIGNALS	MAIN SIGNALS	SELECTION FROM MENU	
RELEASE SW NO	-	-	×	Release switch signal (ON/OFF) status is displayed. "ON" indicates that the brake pedal is depressed. "OFF" is that the brake pedal is released.
RELEASE SW NC	-	-	×	Release switch signal (ON/OFF) status is displayed. "OFF" indicates that the brake pedal is depressed on. "ON" is that the brake pedal is released.
OHB FAIL	-	-	×	OHB fail status is displayed.
HBA FAIL	-	-	×	HBA fail status is displayed.
OHB SIG	-	-	×	OHB operation (ON/OFF) status is displayed.
HBA SIG	-	-	×	HBA operation (ON/OFF) status is displayed.
PRES CTRL ACC	-	-	×	This item is not used for this model.
PRES FAIL ACC	-	-	×	This item is not used for this model.
STP OFF RLY	-	-	×	Stop lamp relay signal (ON/OFF) status is displayed.

×: Applicable

-: Not applicable

## ACTIVE TEST MODE

### CAUTION:

- Do not perform active test while driving vehicle.
- Make sure to completely bleed air from brake system.
- The active test cannot be performed with the ABS warning lamp, VDC OFF indicator lamp, SLIP indicator lamp or brake warning lamp on.
- ABS warning lamp, VDC OFF indicator lamp, SLIP indicator lamp and brake warning lamp are on during active test.

### NOTE:

- When active test is performed while depressing the pedal, the pedal depression amount will change. This is normal. (Only solenoid valve and ABS motor.)
- "TEST IS STOPPED" is displayed 10 seconds after operation start.
- After "TEST IS STOPPED" is displayed, to perform test again, touch BACK.

### Test Item

#### SOLENOID VALVE

- When performing an active test of the ABS function, select the "MAIN SIGNALS" for each test item. In addition, when performing an active test of the VDC/TCS function, select the item menu for each test item.
- For ABS solenoid valve, touch "UP", "KEEP", and "DOWN" on the display screen. For ABS solenoid valve (ACT), touch "UP", "ACT UP", "ACT KEEP" and confirm that solenoid valves operate as shown in the table below.

Operation		ABS solenoid valve			ABS solenoid valve (ACT)		
		UP	KEEP	DOWN	UP	ACTUA-TOR UP	ACTUA-TOR KEEP
FR RH SOL FR RH ABS SOLE- NOID (ACT)	FR RH IN SOL	OFF	ON	ON	OFF	OFF	OFF
	FR RH OUT SOL	OFF	OFF	ON*	OFF	OFF	OFF
FR LH SOL FR LH ABS SOLE- NOID (ACT)	FR LH IN SOL	OFF	ON	ON	OFF	OFF	OFF
	FR LH OUT SOL	OFF	OFF	ON*	OFF	OFF	OFF



# DIAGNOSIS SYSTEM [ABS ACTUATOR AND ELECTRIC UNIT (CONTROL UNIT)]

< FUNCTION DIAGNOSIS >

[VDC/TCS/ABS]

Operation		ABS solenoid valve			ABS solenoid valve (ACT)		
		UP	KEEP	DOWN	UP	ACTUA-TOR UP	ACTUA-TOR KEEP
RR RH SOL RR RH ABS SOLE- NOID (ACT)	RR RH IN SOL	OFF	ON	ON	OFF	OFF	OFF
	RR RH OUT SOL	OFF	OFF	ON*	OFF	OFF	OFF
RR LH SOL RR LH ABS SOLE- NOID (ACT)	RR LH IN SOL	OFF	ON	ON	OFF	OFF	OFF
	RR LH OUT SOL	OFF	OFF	ON*	OFF	OFF	OFF
REAR SOL	RR RH IN SOL	OFF	ON	ON	OFF	OFF	OFF
	RR RH OUT SOL	OFF	OFF	ON*	OFF	OFF	OFF
	RR LH IN SOL	OFF	ON	ON	OFF	OFF	OFF
	RR LH OUT SOL	OFF	OFF	ON*	OFF	OFF	OFF

\*: ON for 1 to 2 seconds after the touch, and then OFF

### ABS MOTOR

- Touch "ON" and "OFF" on screen. Make sure motor relay and actuator relay operates as shown in table below.

Operation	ON	OFF
MOTOR RELAY	ON	OFF
ACTUATOR RLY	ON	ON

### BOOSTER DRIVE

- Touch "UP" and "DOWN" on the screen. Check that booster drive operates as shown in table below.

**CAUTION:**

- **Perform active test subject to the conditions below.**
- **Do not operate brake pedal during active test.**
- **Make sure the engine revolution is over 500 rpm.**
- **Make sure the vehicle is not moving.**

Operation	UP	DOWN
STOP LAMP SW	ON	OFF
BST OPER SIG	ON	OFF
PRESS SENSOR	50 ± 5 bar	0 bar
PRESS SEN 2	50 ± 5 bar	0 bar
STP OFF RLY	OFF	OFF

# C1101, C1102, C1103, C1104 WHEEL SENSOR-1

< COMPONENT DIAGNOSIS >

[VDC/TCS/ABS]

## COMPONENT DIAGNOSIS

### C1101, C1102, C1103, C1104 WHEEL SENSOR-1

#### Description

INFOID:000000001537146

When the sensor rotor rotates, the magnetic field changes. It converts the magnetic field changes to current signals (rectangular wave) and transmits them to the ABS actuator and electric unit (control unit).

#### DTC Logic

INFOID:000000001537147

#### DTC DETECTION LOGIC

DTC	Display item	Malfunction detected condition	Possible cause
C1101	RR RH SENSOR-1	Circuit of rear RH wheel sensor is open. Or when the sensor power voltage is outside the standard.	<ul style="list-style-type: none"><li>• Harness or connector</li><li>• Wheel sensor</li><li>• ABS actuator and electric unit (control unit)</li></ul>
C1102	RR LH SENSOR-1	Circuit of rear LH wheel sensor is open. Or when the sensor power voltage is outside the standard.	
C1103	FR RH SENSOR-1	Circuit of front RH wheel sensor is open. Or when the sensor power voltage is outside the standard.	
C1104	FR LH SENSOR-1	Circuit of front LH wheel sensor is open. Or when the sensor power voltage is outside the standard.	

#### DTC CONFIRMATION PROCEDURE

##### 1. CHECK SELF-DIAGNOSIS RESULTS

Check the self-diagnosis results.

Self-diagnosis results
RR RH SENSOR-1
RR LH SENSOR-1
FR RH SENSOR-1
FR LH SENSOR-1

Is above displayed on the self-diagnosis display?

- YES >> Proceed to diagnosis procedure. Refer to [BRC-170. "Diagnosis Procedure"](#).  
NO >> INSPECTION END

#### Diagnosis Procedure

INFOID:000000001537148

#### **CAUTION:**

**Do not check between wheel sensor terminals.**

#### INSPECTION PROCEDURE

##### 1. CONNECTOR INSPECTION

Disconnect the ABS actuator and electric unit (control unit) connector E125 and wheel sensor of malfunctioning code.

Check the terminals for deformation, disconnection, looseness or damage.

Is the inspection result normal?

- YES >> GO TO 2  
NO >> Repair or replace as necessary.

##### 2. CHECK WHEEL SENSOR OUTPUT SIGNAL

1. Connect ABS active wheel sensor tester (J-45741) to wheel sensor using appropriate adapter.
2. Turn on the ABS active wheel sensor tester power switch.

#### **NOTE:**

The green POWER indicator should illuminate. If the POWER indicator does not illuminate, replace the battery in the ABS active wheel sensor tester before proceeding.

# C1101, C1102, C1103, C1104 WHEEL SENSOR-1

< COMPONENT DIAGNOSIS >

[VDC/TCS/ABS]

- Spin the wheel of the vehicle by hand and observe the red SENSOR indicator on the ABS active wheel sensor tester. The red SENSOR indicator should flash on and off to indicate an output signal.

**NOTE:**

If the red SENSOR indicator illuminates but does not flash, reverse the polarity of the tester leads and retest.

Does the ABS active wheel sensor tester detect a signal?

YES >> GO TO 3

NO >> Replace the wheel sensor. Refer to [BRC-253, "Removal and Installation"](#).

### 3.CHECK TIRES

Check for inflation pressure, wear and size of each tire.

Are tire pressure and size correct and is tire wear within specifications?

YES >> GO TO 4

NO >> Adjust tire pressure or replace tire(s).

### 4.CHECK WHEEL BEARINGS

Check wheel bearing axial end play. Refer to [FAX-5, "On-Vehicle Inspection and Service"](#) (front) or [RAX-5, "On-Vehicle Inspection"](#) (rear).

Is the inspection result normal?

YES >> GO TO 5

NO >> Repair or replace as necessary. Refer to [FAX-6, "Removal and Installation"](#) (front) or [RAX-7, "Removal and Installation"](#) (rear).

### 5.CHECK WIRING HARNESS FOR SHORT CIRCUIT

- Disconnect ABS actuator and electric unit (control unit) connector and wheel sensor connector of malfunction code No.
- Check continuity between wheel sensor harness connector terminals and ground.

**Continuity should not exist.**

Is the inspection result normal?

YES >> GO TO 6

NO >> Repair the circuit.

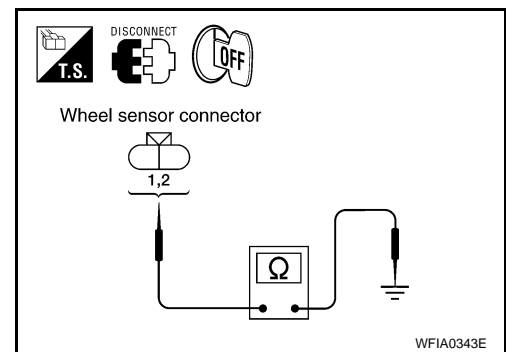

### 6.CHECK WIRING HARNESS FOR OPEN CIRCUIT

- Check continuity between ABS actuator and electric unit (control unit) harness connector E125 and the malfunctioning wheel sensor harness connector E18, E117, C10, or C11.

Wheel sensor	ABS actuator and electric unit (control unit)		Wheel sensor		Continuity
	Connector	Terminal	Connector	Terminal	
Front LH	E125	45	E18	1	Yes
		46		2	
Front RH		34	E117	1	
		33		2	
Rear LH		37	C11	2	
		36		1	
Rear RH		42	C10	2	
		43		1	

Is the inspection result normal?

YES >> Replace the ABS actuator and electric unit (control unit). Refer to [BRC-255, "Removal and Installation"](#).

NO >> Repair the circuit.

# C1101, C1102, C1103, C1104 WHEEL SENSOR-1

< COMPONENT DIAGNOSIS >

[VDC/TCS/ABS]

INFOID:000000001537149

## Component Inspection

### 1. CHECK DATA MONITOR

On "DATA MONITOR", select "FR LH SENSOR", "FR RH SENSOR", "RR LH SENSOR", and "RR RH SENSOR", and check the vehicle speed.

Wheel sensor	Vehicle speed (DATA MONITOR)
FR LH SENSOR	Nearly matches the speedometer display ( $\pm 10\%$ or less)
FR RH SENSOR	
RR LH SENSOR	
RR RH SENSOR	

Is the inspection result normal?

YES >> INSPECTION END

NO >> Go to diagnosis procedure. Refer to [BRC-170, "Diagnosis Procedure"](#).

## Special Repair Requirement

INFOID:000000001537150

### 1. ADJUSTMENT OF STEERING ANGLE SENSOR NEUTRAL POSITION

Always perform neutral position adjustment for the steering angle sensor when replacing the ABS actuator and electric unit (control unit). Refer to [BRC-150, "ADJUSTMENT OF STEERING ANGLE SENSOR NEUTRAL POSITION : Description"](#).

>> GO TO 2

### 2. CALIBRATION OF DECEL G SENSOR

Always perform calibration of decel G sensor when replacing the ABS actuator and electric unit (control unit). Refer to [BRC-151, "CALIBRATION OF DECEL G SENSOR : Description"](#).

>> END

# C1105, C1106, C1107, C1108 WHEEL SENSOR-2

< COMPONENT DIAGNOSIS >

[VDC/TCS/ABS]

## C1105, C1106, C1107, C1108 WHEEL SENSOR-2

### Description

INFOID:000000001537151

When the sensor rotor rotates, the magnetic field changes. It converts the magnetic field changes to current signals (rectangular wave) and transmits them to the ABS actuator and electric unit (control unit).

### DTC Logic

INFOID:000000001537152

### DTC DETECTION LOGIC

DTC	Display item	Malfunction detected condition	Possible cause
C1105	RR RH SENSOR-2	When the circuit in the rear RH wheel sensor is short-circuited. Or when the distance between the wheel sensor and sensor rotor is too large and the sensor pulse cannot be recognized by the control unit.	<ul style="list-style-type: none"><li>• Harness or connector</li><li>• Wheel sensor</li><li>• ABS actuator and electric unit (control unit)</li></ul>
C1106	RR LH SENSOR-2	When the circuit in the rear LH wheel sensor is short-circuited. Or when the distance between the wheel sensor and sensor rotor is too large and the sensor pulse cannot be recognized by the control unit.	
C1107	FR RH SENSOR-2	When the circuit in the front RH wheel sensor is short-circuited. Or when the distance between the wheel sensor and sensor rotor is too large and the sensor pulse cannot be recognized by the control unit.	
C1108	FR LH SENSOR-2	When the circuit in the front LH wheel sensor is short-circuited. Or when the distance between the wheel sensor and sensor rotor is too large and the sensor pulse cannot be recognized by the control unit.	

### DTC CONFIRMATION PROCEDURE

#### 1. CHECK SELF-DIAGNOSIS RESULTS

Check the self-diagnosis results.

Self-diagnosis results
RR RH SENSOR-2
RR LH SENSOR-2
FR RH SENSOR-2
FR LH SENSOR-2

Is above displayed on the self-diagnosis display?

- YES >> Proceed to diagnosis procedure. Refer to [BRC-173, "Diagnosis Procedure"](#).  
NO >> INSPECTION END

### Diagnosis Procedure

INFOID:000000001675426

#### **CAUTION:**

**Do not check between wheel sensor terminals.**

### INSPECTION PROCEDURE

#### 1. CONNECTOR INSPECTION

Disconnect the ABS actuator and electric unit (control unit) connector E125 and wheel sensor of malfunctioning code.

Check the terminals for deformation, disconnection, looseness or damage.

Is the inspection result normal?

- YES >> GO TO 2  
NO >> Repair or replace as necessary.

## C1105, C1106, C1107, C1108 WHEEL SENSOR-2

< COMPONENT DIAGNOSIS >

[VDC/TCS/ABS]

### 2. CHECK WHEEL SENSOR OUTPUT SIGNAL

1. Connect ABS active wheel sensor tester (J-45741) to wheel sensor using appropriate adapter.
2. Turn on the ABS active wheel sensor tester power switch.

**NOTE:**

The green POWER indicator should illuminate. If the POWER indicator does not illuminate, replace the battery in the ABS active wheel sensor tester before proceeding.

3. Spin the wheel of the vehicle by hand and observe the red SENSOR indicator on the ABS active wheel sensor tester. The red SENSOR indicator should flash on and off to indicate an output signal.

**NOTE:**

If the red SENSOR indicator illuminates but does not flash, reverse the polarity of the tester leads and retest.

Does the ABS active wheel sensor tester detect a signal?

YES >> GO TO 3

NO >> Replace the wheel sensor. Refer to [BRC-253. "Removal and Installation"](#).

### 3. CHECK TIRES

Check for inflation pressure, wear and size of each tire.

Are tire pressure and size correct and is tire wear within specifications?

YES >> GO TO 4

NO >> Adjust tire pressure or replace tire(s).

### 4. CHECK WHEEL BEARINGS

Check wheel bearing axial end play. Refer to [FAX-5. "On-Vehicle Inspection and Service"](#) (front) or [RAX-5. "On-Vehicle Inspection"](#) (rear).

Is the inspection result normal?

YES >> GO TO 5

NO >> Repair or replace as necessary. Refer to [FAX-6. "Removal and Installation"](#) (front) or [RAX-7. "Removal and Installation"](#) (rear).

### 5. CHECK WIRING HARNESS FOR SHORT CIRCUIT

1. Disconnect ABS actuator and electric unit (control unit) connector and wheel sensor connector of malfunction code No.
2. Check continuity between wheel sensor harness connector terminals and ground.

**Continuity should not exist.**

Is the inspection result normal?

YES >> GO TO 6

NO >> Repair the circuit.

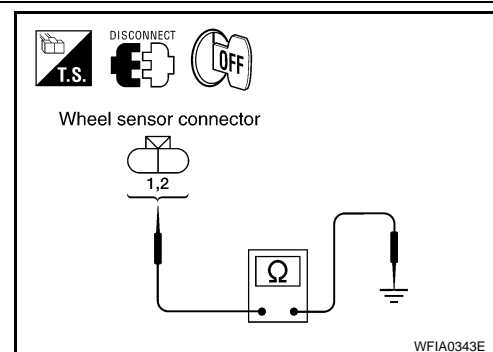

### 6. CHECK WIRING HARNESS FOR OPEN CIRCUIT

1. Check continuity between ABS actuator and electric unit (control unit) harness connector E125 and the malfunctioning wheel sensor harness connector E18, E117, C10, or C11.

# C1105, C1106, C1107, C1108 WHEEL SENSOR-2

< COMPONENT DIAGNOSIS >

[VDC/TCS/ABS]

Wheel sensor	ABS actuator and electric unit (control unit)		Wheel sensor		Continuity
	Connector	Terminal	Connector	Terminal	
Front LH	E125	45	E18	1	Yes
		46		2	
Front RH		34	E117	1	
		33		2	
Rear LH		37	C11	2	
		36		1	
Rear RH		42	C10	2	
		43		1	

Is the inspection result normal?

YES >> Replace the ABS actuator and electric unit (control unit). Refer to [BRC-255, "Removal and Installation"](#).

NO >> Repair the circuit.

## Component Inspection

INFOID:000000001675427

### 1. CHECK DATA MONITOR

On "DATA MONITOR", select "FR LH SENSOR", "FR RH SENSOR", "RR LH SENSOR", and "RR RH SENSOR", and check the vehicle speed.

Wheel sensor	Vehicle speed (DATA MONITOR)
FR LH SENSOR	Nearly matches the speedometer display ( $\pm 10\%$ or less)
FR RH SENSOR	
RR LH SENSOR	
RR RH SENSOR	

Is the inspection result normal?

YES >> INSPECTION END

NO >> Go to diagnosis procedure. Refer to [BRC-173, "Diagnosis Procedure"](#).

## Special Repair Requirement

INFOID:000000001675428

### 1. ADJUSTMENT OF STEERING ANGLE SENSOR NEUTRAL POSITION

Always perform neutral position adjustment for the steering angle sensor when replacing the ABS actuator and electric unit (control unit). Refer to [BRC-150, "ADJUSTMENT OF STEERING ANGLE SENSOR NEUTRAL POSITION : Description"](#).

>> GO TO 2

### 2. CALIBRATION OF DECEL G SENSOR

Always perform calibration of decel G sensor when replacing the ABS actuator and electric unit (control unit). Refer to [BRC-151, "CALIBRATION OF DECEL G SENSOR : Description"](#).

>> END

# C1109 POWER AND GROUND SYSTEM

< COMPONENT DIAGNOSIS >

[VDC/TCS/ABS]

## C1109 POWER AND GROUND SYSTEM

### Description

INFOID:000000001537156

Supplies electric power to the ABS actuator and electric unit (control unit).

### DTC Logic

INFOID:000000001537157

### DTC DETECTION LOGIC

DTC	Display item	Malfunction detected condition	Possible cause
C1109	BATTERY VOLTAGE [ABNORMAL]	When the ABS actuator and electric unit (control unit) power supply voltage is lower than normal.	<ul style="list-style-type: none"> <li>• Harness or connector</li> <li>• ABS actuator and electric unit (control unit)</li> </ul>

### DTC CONFIRMATION PROCEDURE

#### 1. CHECK SELF-DIAGNOSIS RESULTS

Check the self-diagnosis results.

Self-diagnosis results
BATTERY VOLTAGE [ABNORMAL]

Is above displayed on the self-diagnosis display?

- YES >> Proceed to diagnosis procedure. Refer to [BRC-176, "Diagnosis Procedure"](#).  
 NO >> INSPECTION END

### Diagnosis Procedure

INFOID:000000001537158

### INSPECTION PROCEDURE

#### 1. CHECK CONNECTOR

1. Turn ignition switch OFF.
2. Disconnect ABS actuator and electric unit (control unit) connector.
3. Check terminal for deformation, disconnection, looseness, and so on. If any malfunction is found, repair or replace terminal.
4. Reconnect connectors and then perform the self-diagnosis. Refer to [BRC-165, "CONSULT-III Function \(ABS\)"](#).

Is any item indicated on the self-diagnosis display?

- YES >> GO TO 2  
 NO >> Poor connection of connector terminal. Repair or replace connector.

#### 2. CHECK ABS ACTUATOR AND ELECTRIC UNIT (CONTROL UNIT) POWER SUPPLY CIRCUIT AND GROUND CIRCUIT

1. Turn ignition switch OFF.
2. Disconnect ABS actuator and electric unit (control unit) connector.
3. Turn ignition switch ON or OFF and check voltage between ABS actuator and electric unit (control unit) harness connector terminal and ground.

ABS actuator and electric unit (control unit)		—	Condition	Voltage
Connector	Terminal			
E125	4	Ground	Ignition switch: ON	Battery voltage
			Ignition switch: OFF	Approx. 0V

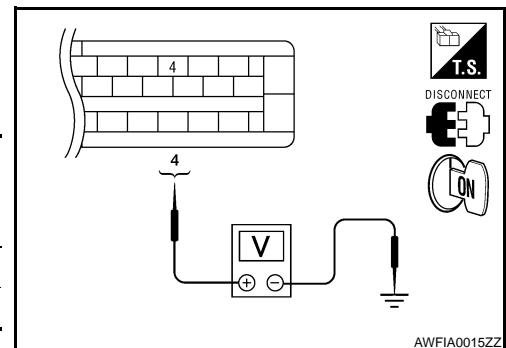

4. Turn ignition switch OFF.



# C1109 POWER AND GROUND SYSTEM

[VDC/TCS/ABS]

## < COMPONENT DIAGNOSIS >

5. Check continuity between ABS actuator and electric unit (control unit) harness connector terminals and ground.

ABS actuator and electric unit (control unit)		—	Continuity
Connector	Terminal		
E125	16, 47	Ground	Yes

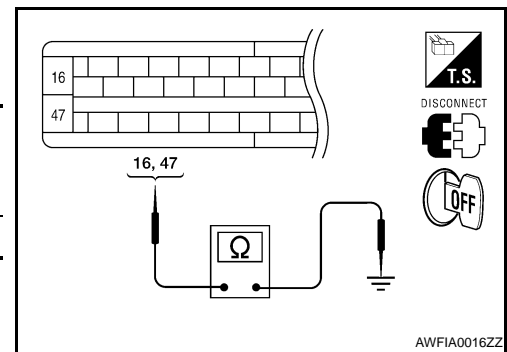

### Is the inspection result normal?

- YES >> Check battery for terminal looseness, low voltage, etc. If any malfunction is found, repair malfunctioning parts.  
 NO >> Repair or replace malfunctioning components.

### Special Repair Requirement

INFOID:000000001675429

**BRC**

## 1. ADJUSTMENT OF STEERING ANGLE SENSOR NEUTRAL POSITION

Always perform neutral position adjustment for the steering angle sensor when replacing the ABS actuator and electric unit (control unit). Refer to [BRC-150. "ADJUSTMENT OF STEERING ANGLE SENSOR NEUTRAL POSITION : Description"](#).

>> GO TO 2

## 2. CALIBRATION OF DECEL G SENSOR

Always perform calibration of decel G sensor when replacing the ABS actuator and electric unit (control unit). Refer to [BRC-151. "CALIBRATION OF DECEL G SENSOR : Description"](#).

>> END

A  
B  
C  
D  
E  
G  
H  
I  
J  
K  
L  
M  
N  
O  
P

# C1110, C1170 ABS ACTUATOR AND ELECTRIC UNIT (CONTROL UNIT)

< COMPONENT DIAGNOSIS >

[VDC/TCS/ABS]

## C1110, C1170 ABS ACTUATOR AND ELECTRIC UNIT (CONTROL UNIT)

### DTC Logic

INFOID:000000001537160

#### DTC DETECTION LOGIC

DTC	Display item	Malfunction detected condition	Possible cause
C1110	CONTROLLER FAILURE	When there is an internal malfunction in the ABS actuator and electric unit (control unit).	• ABS actuator and electric unit (control unit)
C1170	VARIANT CODING	In a case where VARIANT CODING is different.	

#### DTC CONFIRMATION PROCEDURE

##### 1. CHECK SELF-DIAGNOSIS RESULTS

Check the self-diagnosis results.

Self-diagnosis results
CONTROLLER FAILURE
VARIANT CODING

Is above displayed on the self-diagnosis display?

YES >> Proceed to diagnosis procedure. Refer to [BRC-178, "Diagnosis Procedure"](#).

NO >> INSPECTION END

#### Diagnosis Procedure

INFOID:000000001675430

#### INSPECTION PROCEDURE

##### 1. REPLACE ABS ACTUATOR AND ELECTRIC UNIT (CONTROL UNIT)

>> Replace ABS actuator and electric unit (control unit). Refer to [BRC-255, "Removal and Installation"](#).

#### Special Repair Requirement

INFOID:000000001675430

##### 1. ADJUSTMENT OF STEERING ANGLE SENSOR NEUTRAL POSITION

Always perform neutral position adjustment for the steering angle sensor when replacing the ABS actuator and electric unit (control unit). Refer to [BRC-150, "ADJUSTMENT OF STEERING ANGLE SENSOR NEUTRAL POSITION : Description"](#).

>> GO TO 2

##### 2. CALIBRATION OF DECEL G SENSOR

Always perform calibration of decel G sensor when replacing the ABS actuator and electric unit (control unit). Refer to [BRC-151, "CALIBRATION OF DECEL G SENSOR : Description"](#).

>> END

# C1111 ABS MOTOR, MOTOR RELAY SYSTEM

< COMPONENT DIAGNOSIS >

[VDC/TCS/ABS]

## C1111 ABS MOTOR, MOTOR RELAY SYSTEM

### Description

INFOID:000000001537163

#### PUMP

The pump returns the brake fluid stored in the reservoir to the master cylinder by reducing the pressure.

#### MOTOR

The motor drives the pump according to the signals transmitted by the ABS actuator and electric unit (control unit).

### DTC Logic

INFOID:000000001537164

### DTC DETECTION LOGIC

DTC	Display item	Malfunction detected condition	Possible cause
C1111	PUMP MOTOR	During the actuator motor operating with ON, when the actuator motor turns OFF, or when the control line for actuator motor relay is open.	<ul style="list-style-type: none"><li>• Harness or connector</li><li>• ABS actuator and electric unit (control unit)</li></ul>
		During the actuator motor operating with OFF, when the actuator motor turns ON, or when the control line for relay is shorted to ground.	

### DTC CONFIRMATION PROCEDURE

#### 1.CHECK SELF-DIAGNOSIS RESULTS

Check the self-diagnosis results.

Self-diagnosis results
PUMP MOTOR

Is above displayed on the self-diagnosis display?

- YES >> Proceed to diagnosis procedure. Refer to [BRC-179, "Diagnosis Procedure"](#).  
NO >> INSPECTION END

### Diagnosis Procedure

INFOID:000000001537165

### INSPECTION PROCEDURE

#### 1.CHECK CONNECTOR

1. Turn ignition switch OFF.
2. Disconnect ABS actuator and electric unit (control unit) connector.
3. Check terminal for deformation, disconnect, looseness, and so on. If any malfunction is found, repair or replace terminal.
4. Reconnect connectors and then perform the self-diagnosis. Refer to [BRC-165, "CONSULT-III Function \(ABS\)"](#).

Is any item indicated on the self-diagnosis display?

- YES >> GO TO 2  
NO >> Poor connection of connector terminal. Repair or replace connector.

#### 2.CHECK ABS MOTOR AND MOTOR RELAY POWER SUPPLY CIRCUIT

# C1111 ABS MOTOR, MOTOR RELAY SYSTEM

[VDC/TCS/ABS]

## < COMPONENT DIAGNOSIS >

1. Turn ignition switch OFF.
2. Disconnect ABS actuator and electric unit (control unit) connector.
3. Check voltage between the ABS actuator and electric unit (control unit) harness connector terminal and ground.

ABS actuator and electric unit (control unit)		—	Voltage
Connector	Terminal		
E125	1	Ground	Battery voltage

Is the inspection result normal?

- YES >> GO TO 3  
 NO >> Repair or replace malfunctioning components.

### 3.CHECK ABS ACTUATOR AND ELECTRIC UNIT (CONTROL UNIT) GROUND CIRCUIT

Check continuity between ABS actuator and electric unit (control unit) harness connector terminals and ground.

ABS actuator and electric unit (control unit)		—	Continuity
Connector	Terminal		
E125	16, 47	Ground	Yes

Is the inspection result normal?

- YES >> Replace ABS actuator and electric unit (control unit).  
 Refer to [BRC-255, "Removal and Installation"](#).  
 NO >> Repair or replace malfunctioning components.

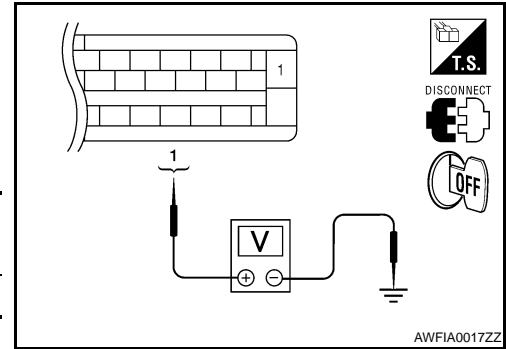

AWFIA0017ZZ

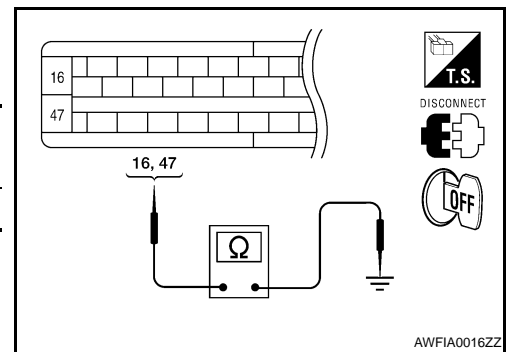

AWFIA0016ZZ

## Component Inspection

INFOID:000000001537166

### 1.CHECK ACTIVE TEST

1. On "ACTIVE TEST", select "ABS MOTOR".
2. Touch ON and OFF on screen. Make sure motor relay and actuator relay operates as shown in table below.

Operation	ON	OFF
MOTOR RELAY	ON	OFF
ACTUATOR RLY	ON	ON

Is the inspection result normal?

- YES >> INSPECTION END  
 NO >> Go to diagnosis procedure. Refer to [BRC-179, "Diagnosis Procedure"](#).

## Special Repair Requirement

INFOID:000000001675431

### 1.ADJUSTMENT OF STEERING ANGLE SENSOR NEUTRAL POSITION

Always perform neutral position adjustment for the steering angle sensor when replacing the ABS actuator and electric unit (control unit). Refer to [BRC-150, "ADJUSTMENT OF STEERING ANGLE SENSOR NEUTRAL POSITION : Description"](#).

>> GO TO 2

### 2.CALIBRATION OF DECEL G SENSOR

Always perform calibration of decel G sensor when replacing the ABS actuator and electric unit (control unit). Refer to [BRC-151, "CALIBRATION OF DECEL G SENSOR : Description"](#).

>> END

# C1113, C1145, C1146 YAW RATE/SIDE/DECEL G SENSOR

< COMPONENT DIAGNOSIS >

[VDC/TCS/ABS]

## C1113, C1145, C1146 YAW RATE/SIDE/DECEL G SENSOR

### Description

INFOID:000000001537168

The yaw rate/side/decel G sensor detects the yaw rate/side/decel G affecting the vehicle, and transmits the data to the ABS actuator and electric unit (control unit) as an analog voltage signal.

### DTC Logic

INFOID:000000001537169

### DTC DETECTION LOGIC

DTC	Display item	Malfunction detected condition	Possible cause
C1113	G-SENSOR	Longitudinal G-sensor is malfunctioning, or signal line of longitudinal G-sensor is open or shorted.	• Harness or connector • ABS actuator and electric unit (control unit) • Yaw rate/side/decel G sensor
C1145	YAW RATE SENSOR	Yaw rate sensor is malfunctioning, or the yaw rate sensor signal line is open or shorted.	
C1146	SIDE G-SEN CIRCUIT	Side G sensor is malfunctioning, or circuit of side G sensor is open or shorted.	

### DTC CONFIRMATION PROCEDURE

#### 1. CHECK SELF-DIAGNOSIS RESULTS

Check the self-diagnosis results.

Self-diagnosis results
G-SENSOR
YAW RATE SENSOR
SIDE G-SEN CIRCUIT

Is above displayed on the self-diagnosis display?

- YES >> Proceed to diagnosis procedure. Refer to [BRC-181, "Diagnosis Procedure"](#).  
NO >> INSPECTION END

### Diagnosis Procedure

INFOID:000000001537170

#### CAUTION:

- Sudden turns (such as spin turns, acceleration turns), drifting, etc. when VDC function is OFF may cause the yaw rate/side/decel G sensor system to indicate a malfunction. This is not a malfunction if normal operation can be resumed after restarting the engine.
- If vehicle is on turn table at entrance to parking garage, or on other moving surface, VDC OFF indicator lamp may illuminate and CONSULT-III self-diagnosis may indicate yaw rate sensor system malfunction. However, in this case there is no malfunction in yaw rate sensor system. Take vehicle off of turn table or other moving surface, and start engine. Results will return to normal.

### INSPECTION PROCEDURE

#### 1. CONNECTOR INSPECTION

Disconnect the ABS actuator and electric unit (control unit) connector E125 and yaw rate/side/decel G sensor connector M108.

Check the terminals for deformation, disconnection, looseness or damage.

Is the inspection result normal?

- YES >> GO TO 2  
NO >> Repair or replace as necessary.

#### 2. YAW RATE/SIDE/DECEL G SENSOR HARNESS INSPECTION

# C1113, C1145, C1146 YAW RATE/SIDE/DECCEL G SENSOR

< COMPONENT DIAGNOSIS >

[VDC/TCS/ABS]

Check continuity between the ABS actuator and electric unit (control unit) connector E125 (A) and the yaw rate/side/deccl G sensor connector M108 (B).

ABS actuator and electric unit (control unit)		Yaw rate/side/deccl G sensor		Continuity
Connector	Terminal	Connector	Terminal	
A: E125	6	B: M108	3	Yes
	24		5	
	25		1	
	29		2	

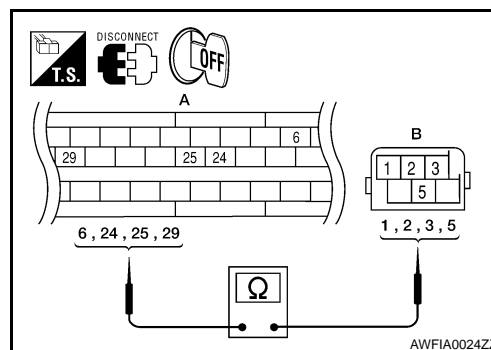

Is the inspection result normal?

- YES >> GO TO 3
- NO >> Repair or replace as necessary.

## 3. YAW RATE/SIDE/DECCEL G SENSOR INSPECTION

1. Connect the yaw rate/side/deccl G sensor connector M108 and ABS actuator and electric unit (control unit) connector E125.
2. Use "DATA MONITOR" to check if the yaw rate/side/deccl G sensor signals are normal.

Vehicle condition	YAW RATE SEN (DATA MONITOR)	SIDE G-SENSOR (DATA MONITOR)	DECCEL G-SEN (DATA MONITOR)
Stopped	-4 to +4 deg/s	-1.1 to +1.1 m/s	-0.11 G to +0.11 G
Turning right	Negative value	Negative value	-
Turning left	Positive value	Positive value	-
Speed up	-	-	Negative value
Speed down	-	-	Positive value

Is the inspection result normal?

- YES >> Replace the ABS actuator and electric unit (control unit). Refer to [BRC-255, "Removal and Installation"](#).
- NO >> Replace the yaw rate/side/deccl G sensor and perform calibration of deccl G-sensor. Refer to [BRC-258, "Removal and Installation"](#).

## Component Inspection

INFOID:000000001537171

### 1. CHECK DATA MONITOR

Select "YAW RATE SEN", "SIDE G-SENSOR", "DECCEL G-SEN" in "DATA MONITOR" and check yaw rate/side/deccl G sensor signal.

Vehicle condition	YAW RATE SEN (DATA MONITOR)	SIDE G-SENSOR (DATA MONITOR)	DECCEL G-SEN (DATA MONITOR)
Stopped	-4 to +4 deg/s	-1.1 to +1.1 m/s	-0.11 G to +0.11 G
Turning right	Negative value	Negative value	-
Turning left	Positive value	Positive value	-
Speed up	-	-	Negative value
Speed down	-	-	Positive value

Is the inspection result normal?

- YES >> INSPECTION END
- NO >> Go to diagnosis procedure. Refer to [BRC-181, "Diagnosis Procedure"](#).

## Special Repair Requirement

INFOID:000000001675432

### 1. ADJUSTMENT OF STEERING ANGLE SENSOR NEUTRAL POSITION

# C1113, C1145, C1146 YAW RATE/SIDE/DECEL G SENSOR

< COMPONENT DIAGNOSIS >

[VDC/TCS/ABS]

Always perform neutral position adjustment for the steering angle sensor when replacing the ABS actuator and electric unit (control unit). Refer to [BRC-150, "ADJUSTMENT OF STEERING ANGLE SENSOR NEUTRAL POSITION : Description"](#).

A

>> GO TO 2

B

## 2. CALIBRATION OF DECEL G SENSOR

Always perform calibration of decel G sensor when replacing the ABS actuator and electric unit (control unit). Refer to [BRC-151, "CALIBRATION OF DECEL G SENSOR : Description"](#).

C

>> END

D

E

BRC

G

H

I

J

K

L

M

N

O

P

# C1115 WHEEL SENSOR

< COMPONENT DIAGNOSIS >

[VDC/TCS/ABS]

## C1115 WHEEL SENSOR

### Description

INFOID:000000001537173

When the sensor rotor rotates, the magnetic field changes. It converts the magnetic field changes to current signals (rectangular wave) and transmits them to the ABS actuator and electric unit (control unit).

### DTC Logic

INFOID:000000001537174

### DTC DETECTION LOGIC

DTC	Display item	Malfunction detected condition	Possible cause
C1115	ABS SENSOR [ABNORMAL SIGNAL]	When wheel sensor input signal is malfunctioning.	<ul style="list-style-type: none"><li>• Harness or connector</li><li>• Wheel sensor</li><li>• ABS actuator and electric unit (control unit)</li></ul>

### DTC CONFIRMATION PROCEDURE

#### 1.CHECK SELF-DIAGNOSIS RESULTS

Check the self-diagnosis results.

Self-diagnosis results
ABS SENSOR [ABNORMAL SIGNAL]

Is above displayed on the self-diagnosis display?

- YES >> Proceed to diagnosis procedure. Refer to [BRC-184, "Diagnosis Procedure"](#).  
NO >> INSPECTION END

### Diagnosis Procedure

INFOID:000000001675433

#### **CAUTION:**

**Do not check between wheel sensor terminals.**

### INSPECTION PROCEDURE

#### 1.CONNECTOR INSPECTION

Disconnect the ABS actuator and electric unit (control unit) connector E125 and wheel sensor of malfunctioning code.

Check the terminals for deformation, disconnection, looseness or damage.

Is the inspection result normal?

- YES >> GO TO 2  
NO >> Repair or replace as necessary.

#### 2.CHECK WHEEL SENSOR OUTPUT SIGNAL

1. Connect ABS active wheel sensor tester (J-45741) to wheel sensor using appropriate adapter.
2. Turn on the ABS active wheel sensor tester power switch.

#### **NOTE:**

The green POWER indicator should illuminate. If the POWER indicator does not illuminate, replace the battery in the ABS active wheel sensor tester before proceeding.

3. Spin the wheel of the vehicle by hand and observe the red SENSOR indicator on the ABS active wheel sensor tester. The red SENSOR indicator should flash on and off to indicate an output signal.

#### **NOTE:**

If the red SENSOR indicator illuminates but does not flash, reverse the polarity of the tester leads and retest.

Does the ABS active wheel sensor tester detect a signal?

- YES >> GO TO 3  
NO >> Replace the wheel sensor. Refer to [BRC-253, "Removal and Installation"](#).

#### 3.CHECK TIRES



# C1115 WHEEL SENSOR

[VDC/TCS/ABS]

## < COMPONENT DIAGNOSIS >

Check for inflation pressure, wear and size of each tire.

Are tire pressure and size correct and is tire wear within specifications?

- YES >> GO TO 4
- NO >> Adjust tire pressure or replace tire(s).

### 4.CHECK WHEEL BEARINGS

Check wheel bearing axial end play. Refer to [FAX-5, "On-Vehicle Inspection and Service"](#) (front) or [RAX-5, "On-Vehicle Inspection"](#) (rear).

Is the inspection result normal?

- YES >> GO TO 5
- NO >> Repair or replace as necessary. Refer to [FAX-6, "Removal and Installation"](#) (front) or [RAX-7, "Removal and Installation"](#) (rear).

### 5.CHECK WIRING HARNESS FOR SHORT CIRCUIT

1. Disconnect ABS actuator and electric unit (control unit) connector and wheel sensor connector of malfunction code No.
2. Check continuity between wheel sensor harness connector terminals and ground.

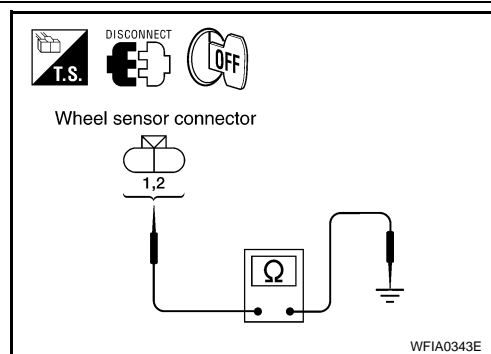

**Continuity should not exist.**

Is the inspection result normal?

- YES >> GO TO 6
- NO >> Repair the circuit.

### 6.CHECK WIRING HARNESS FOR OPEN CIRCUIT

1. Check continuity between ABS actuator and electric unit (control unit) harness connector E125 and the malfunctioning wheel sensor harness connector E18, E117, C10, or C11.

Wheel sensor	ABS actuator and electric unit (control unit)		Wheel sensor		Continuity
	Connector	Terminal	Connector	Terminal	
Front LH	E125	45	E18	1	Yes
		46		2	
Front RH		34	E117	1	
		33		2	
Rear LH		37	C11	2	
		36		1	
Rear RH		42	C10	2	
		43		1	

Is the inspection result normal?

- YES >> Replace the ABS actuator and electric unit (control unit). Refer to [BRC-255, "Removal and Installation"](#).
- NO >> Repair the circuit.

## Component Inspection

INFOID:000000001675434

### 1.CHECK DATA MONITOR

On "DATA MONITOR", select "FR LH SENSOR", "FR RH SENSOR", "RR LH SENSOR", and "RR RH SENSOR", and check the vehicle speed.

Wheel sensor	Vehicle speed (DATA MONITOR)
--------------	------------------------------

# C1115 WHEEL SENSOR

[VDC/TCS/ABS]

< COMPONENT DIAGNOSIS >

FR LH SENSOR	Nearly matches the speedometer display ( $\pm 10\%$ or less)
FR RH SENSOR	
RR LH SENSOR	
RR RH SENSOR	

Is the inspection result normal?

YES >> INSPECTION END

NO >> Go to diagnosis procedure. Refer to [BRC-184, "Diagnosis Procedure"](#).

## Special Repair Requirement

INFOID:000000001675435

### 1. ADJUSTMENT OF STEERING ANGLE SENSOR NEUTRAL POSITION

Always perform neutral position adjustment for the steering angle sensor when replacing the ABS actuator and electric unit (control unit). Refer to [BRC-150, "ADJUSTMENT OF STEERING ANGLE SENSOR NEUTRAL POSITION : Description"](#).

>> GO TO 2

### 2. CALIBRATION OF DECEL G SENSOR

Always perform calibration of decel G sensor when replacing the ABS actuator and electric unit (control unit). Refer to [BRC-151, "CALIBRATION OF DECEL G SENSOR : Description"](#).

>> END

# C1116 STOP LAMP SWITCH

< COMPONENT DIAGNOSIS >

[VDC/TCS/ABS]

## C1116 STOP LAMP SWITCH

### Description

INFOID:000000001537178

The stop lamp switch transmits the stop lamp switch signal (ON/OFF) to the ABS actuator and electric unit (control unit).

### DTC Logic

INFOID:000000001537179

### DTC DETECTION LOGIC

DTC	Display item	Malfunction detected condition	Possible cause
C1116	STOP LAMP SW	When stop lamp switch circuit is open.	<ul style="list-style-type: none"><li>• Harness or connector</li><li>• Stop lamp switch</li><li>• ABS actuator and electric unit (control unit)</li></ul>

### DTC CONFIRMATION PROCEDURE

#### 1. CHECK SELF-DIAGNOSIS RESULTS

Check the self-diagnosis results.

Self-diagnosis results
STOP LAMP SW

Is above displayed on the self-diagnosis display?

- YES >> Proceed to diagnosis procedure. Refer to [BRC-187. "Diagnosis Procedure"](#).  
NO >> INSPECTION END

### Diagnosis Procedure

INFOID:000000001537180

### INSPECTION PROCEDURE

#### 1. CONNECTOR INSPECTION

1. Disconnect the ABS actuator and electric unit (control unit) connector E125 and stop lamp switch connector E38.
2. Check the terminals for deformation, disconnection, looseness or damage.

Is the inspection result normal?

- YES >> GO TO 2  
NO >> Repair or replace as necessary.

#### 2. STOP LAMP SWITCH INSPECTION

Check the voltage between the ABS actuator and electric unit (control unit) harness connector E125 terminal 41 and body ground.

**Brake pedal depressed : Battery voltage (approx. 12V)**

**Brake pedal not depressed : Approx. 0V**

Is the inspection result normal?

- YES >> Perform self-diagnosis again. If the same results appear, replace ABS actuator and electric unit (control unit). Refer to [BRC-255. "Removal and Installation"](#).  
NO >> GO TO 3

#### 3. STOP LAMP RELAY CIRCUIT INSPECTION

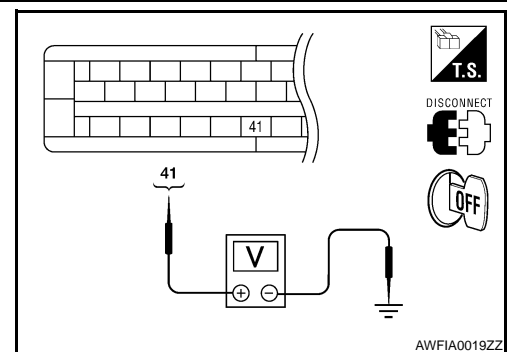

# C1116 STOP LAMP SWITCH

[VDC/TCS/ABS]

## < COMPONENT DIAGNOSIS >

1. Disconnect the stop lamp relay harness connector E12.
2. Check the continuity between the ABS actuator and electric unit (control unit) harness connector E125 (B) terminal 41 and stop lamp relay harness connector E12 (A) terminal 4.

**Continuity should exist.**

Is the inspection result normal?

- YES >> Refer to [EXL-3, "Work Flow"](#).  
NO >> Repair or replace malfunctioning components.

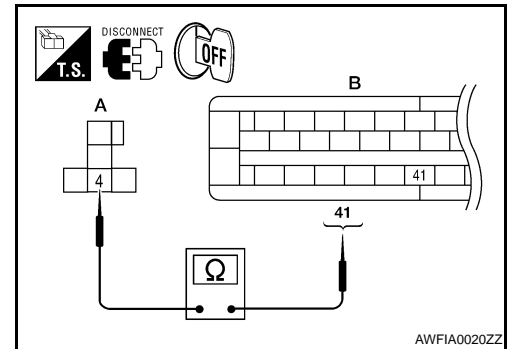

## Special Repair Requirement

INFOID:000000001675436

### 1. ADJUSTMENT OF STEERING ANGLE SENSOR NEUTRAL POSITION

Always perform neutral position adjustment for the steering angle sensor when replacing the ABS actuator and electric unit (control unit). Refer to [BRC-150, "ADJUSTMENT OF STEERING ANGLE SENSOR NEUTRAL POSITION : Description"](#).

>> GO TO 2

### 2. CALIBRATION OF DECEL G SENSOR

Always perform calibration of decel G sensor when replacing the ABS actuator and electric unit (control unit). Refer to [BRC-151, "CALIBRATION OF DECEL G SENSOR : Description"](#).

>> END

# C1120, C1122, C1124, C1126 IN ABS SOL

< COMPONENT DIAGNOSIS >

[VDC/TCS/ABS]

## C1120, C1122, C1124, C1126 IN ABS SOL

### Description

INFOID:000000001537182

The solenoid valve increases, holds or decreases the fluid pressure of each brake caliper according to the signals transmitted by the ABS actuator and electric unit (control unit).

### DTC Logic

INFOID:000000001537183

### DTC DETECTION LOGIC

DTC	Display item	Malfunction detected condition	Possible cause
C1120	FR LH IN ABS SOL	When the control unit detects a malfunction in the front LH inlet solenoid circuit.	• ABS actuator and electric unit (control unit)
C1122	FR RH IN ABS SOL	When the control unit detects a malfunction in the front RH inlet solenoid circuit.	
C1124	RR LH IN ABS SOL	When the control unit detects a malfunction in the rear LH inlet solenoid circuit.	
C1126	RR RH IN ABS SOL	When the control unit detects a malfunction in the rear RH inlet solenoid circuit.	

### DTC CONFIRMATION PROCEDURE

#### 1.CHECK SELF-DIAGNOSIS RESULTS

Check the self-diagnosis results.

Self-diagnosis results
FR LH IN ABS SOL
FR RH IN ABS SOL
RR LH IN ABS SOL
RR RH IN ABS SOL

Is above displayed on the self-diagnosis display?

- YES >> Proceed to diagnosis procedure. Refer to [BRC-189. "Diagnosis Procedure"](#).  
NO >> INSPECTION END

### Diagnosis Procedure

INFOID:000000001537184

### INSPECTION PROCEDURE

#### 1.CHECK CONNECTOR

1. Turn ignition switch OFF.
2. Disconnect ABS actuator and electric unit (control unit) connector.
3. Check terminal for deformation, disconnection, looseness, and so on. If any malfunction is found, repair or replace terminal.
4. Reconnect connectors and then perform the self-diagnosis. Refer to [BRC-165. "CONSULT-III Function \(ABS\)"](#).

Is any item indicated on the self-diagnosis display?

- YES >> GO TO 2  
NO >> Poor connection of connector terminal. Repair or replace connector.

#### 2.CHECK SOLENOID, VDC SWITCH-OVER VALVE AND ACTUATOR RELAY POWER SUPPLY CIRCUIT

# C1120, C1122, C1124, C1126 IN ABS SOL

[VDC/TCS/ABS]

## < COMPONENT DIAGNOSIS >

1. Turn ignition switch OFF.
2. Disconnect ABS actuator and electric unit (control unit) connector.
3. Check voltage between ABS actuator and electric unit (control unit) harness connector terminal and ground.

ABS actuator and electric unit (control unit)		—	Voltage
Connector	Terminal		
E125	32	Ground	Battery voltage

Is the inspection result normal?

- YES >> GO TO 3  
 NO >> Repair or replace malfunctioning components.

### 3.CHECK SOLENOID, VDC SWITCH-OVER VALVE AND ACUATOR RELAY GROUND CIRCUIT

Check continuity between ABS actuator and electric unit (control unit) harness connector terminals and ground.

ABS actuator and electric unit (control unit)		—	Continuity
Connector	Terminal		
E125	16, 47	Ground	Yes

Is the inspection result normal?

- YES >> Replace ABS actuator and electric unit (control unit).  
 Refer to [BRC-255, "Removal and Installation"](#).  
 NO >> Repair or replace malfunctioning components.

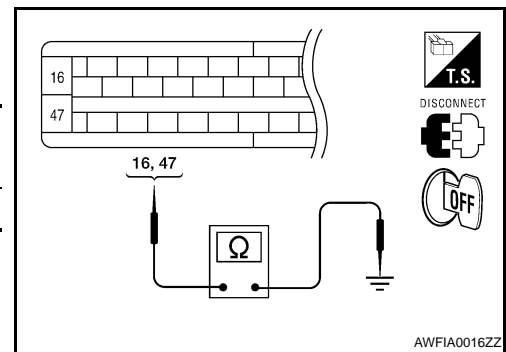
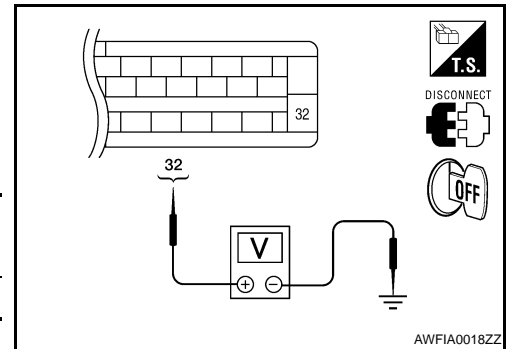

## Component Inspection

INFOID:000000001537185

### 1.CHECK ACTIVE TEST

1. Select each test menu item on "ACTIVE TEST".
2. On the display, touch "UP", "KEEP", and "DOWN", and check that the system operates as shown in the table below.

Operation		ABS solenoid valve			ABS solenoid valve (ACT)		
		UP	KEEP	DOWN	UP	ACTUA-TOR UP	ACTUA-TOR KEEP
FR RH SOL FR RH ABS SOLE- NOID (ACT)	FR RH IN SOL	OFF	ON	ON	OFF	OFF	OFF
	FR RH OUT SOL	OFF	OFF	ON*	OFF	OFF	OFF
FR LH SOL FR LH ABS SOLE- NOID (ACT)	FR LH IN SOL	OFF	ON	ON	OFF	OFF	OFF
	FR LH OUT SOL	OFF	OFF	ON*	OFF	OFF	OFF
RR RH SOL RR RH ABS SOLE- NOID (ACT)	RR RH IN SOL	OFF	ON	ON	OFF	OFF	OFF
	RR RH OUT SOL	OFF	OFF	ON*	OFF	OFF	OFF
RR LH SOL RR LH ABS SOLE- NOID (ACT)	RR LH IN SOL	OFF	ON	ON	OFF	OFF	OFF
	RR LH OUT SOL	OFF	OFF	ON*	OFF	OFF	OFF
REAR SOL	RR RH IN SOL	OFF	ON	ON	OFF	OFF	OFF
	RR RH OUT SOL	OFF	OFF	ON*	OFF	OFF	OFF
	RR LH IN SOL	OFF	ON	ON	OFF	OFF	OFF
	RR LH OUT SOL	OFF	OFF	ON*	OFF	OFF	OFF

\*: ON for 1 to 2 seconds after the touch, and then OFF

Is the inspection result normal?

- YES >> INSPECTION END

# C1120, C1122, C1124, C1126 IN ABS SOL

< COMPONENT DIAGNOSIS >

[VDC/TCS/ABS]

NO >> Go to diagnosis procedure. Refer to [BRC-189. "Diagnosis Procedure"](#).

## Special Repair Requirement

INFOID:000000001675437

### 1.AJUSTMENT OF STEERING ANGLE SENSOR NEUTRAL POSITION

Always perform neutral position adjustment for the steering angle sensor when replacing the ABS actuator and electric unit (control unit). Refer to [BRC-150. "ADJUSTMENT OF STEERING ANGLE SENSOR NEUTRAL POSITION : Description"](#).

>> GO TO 2

### 2.CALIBRATION OF DECEL G SENSOR

Always perform calibration of decel G sensor when replacing the ABS actuator and electric unit (control unit). Refer to [BRC-151. "CALIBRATION OF DECEL G SENSOR : Description"](#).

>> END

A  
B  
C  
D  
E  
G  
H  
I  
J  
K  
L  
M  
N  
O  
P

**BRC**

# C1121, C1123, C1125, C1127 OUT ABS SOL

< COMPONENT DIAGNOSIS >

[VDC/TCS/ABS]

## C1121, C1123, C1125, C1127 OUT ABS SOL

### Description

INFOID:000000001537187

The solenoid valve increases, holds or decreases the fluid pressure of each brake caliper according to the signals transmitted by the ABS actuator and electric unit (control unit).

### DTC Logic

INFOID:000000001537188

### DTC DETECTION LOGIC

DTC	Display item	Malfunction detected condition	Possible cause
C1121	FR LH OUT ABS SOL	When the control unit detects a malfunction in the front LH outlet solenoid circuit.	• ABS actuator and electric unit (control unit)
C1123	FR RH OUT ABS SOL	When the control unit detects a malfunction in the front RH outlet solenoid circuit.	
C1125	RR LH OUT ABS SOL	When the control unit detects a malfunction in the rear LH outlet solenoid circuit.	
C1127	RR RH OUT ABS SOL	When the control unit detects a malfunction in the rear RH outlet solenoid circuit.	

### DTC CONFIRMATION PROCEDURE

#### 1. CHECK SELF-DIAGNOSIS RESULTS

Check the self-diagnosis results.

Self-diagnosis results
FR LH OUT ABS SOL
FR RH OUT ABS SOL
RR LH OUT ABS SOL
RR RH OUT ABS SOL

Is above displayed on the self-diagnosis display?

- YES >> Proceed to diagnosis procedure. Refer to [BRC-192. "Diagnosis Procedure"](#).  
NO >> INSPECTION END

### Diagnosis Procedure

INFOID:000000001675438

### INSPECTION PROCEDURE

#### 1. CHECK CONNECTOR

1. Turn ignition switch OFF.
2. Disconnect ABS actuator and electric unit (control unit) connector.
3. Check terminal for deformation, disconnection, looseness, and so on. If any malfunction is found, repair or replace terminal.
4. Reconnect connectors and then perform the self-diagnosis. Refer to [BRC-165. "CONSULT-III Function \(ABS\)"](#).

Is any item indicated on the self-diagnosis display?

- YES >> GO TO 2  
NO >> Poor connection of connector terminal. Repair or replace connector.

#### 2. CHECK SOLENOID, VDC SWITCH-OVER VALVE AND ACTUATOR RELAY POWER SUPPLY CIRCUIT



# C1121, C1123, C1125, C1127 OUT ABS SOL

[VDC/TCS/ABS]

## < COMPONENT DIAGNOSIS >

1. Turn ignition switch OFF.
2. Disconnect ABS actuator and electric unit (control unit) connector.
3. Check voltage between ABS actuator and electric unit (control unit) harness connector terminal and ground.

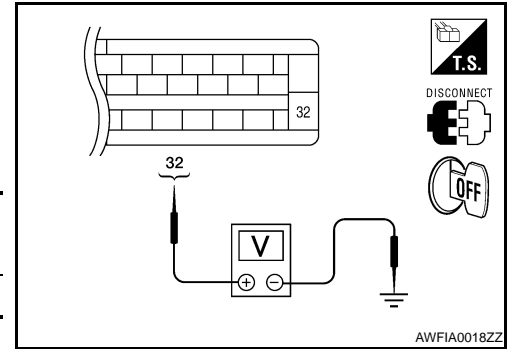

ABS actuator and electric unit (control unit)		—	Voltage
Connector	Terminal		
E125	32	Ground	Battery voltage

Is the inspection result normal?

- YES >> GO TO 3  
 NO >> Repair or replace malfunctioning components.

### 3.CHECK SOLENOID, VDC SWITCH-OVER VALVE AND ACUATOR RELAY GROUND CIRCUIT

Check continuity between ABS actuator and electric unit (control unit) harness connector terminals and ground.

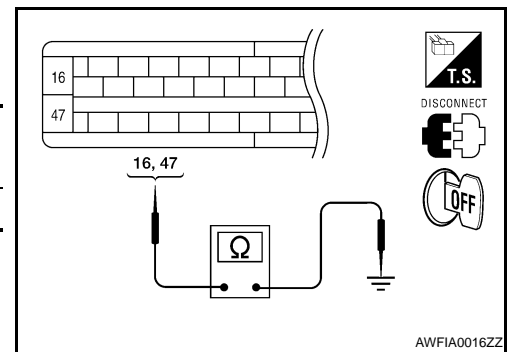

ABS actuator and electric unit (control unit)		—	Continuity
Connector	Terminal		
E125	16, 47	Ground	Yes

Is the inspection result normal?

- YES >> Replace ABS actuator and electric unit (control unit).  
 Refer to [BRC-255, "Removal and Installation"](#).  
 NO >> Repair or replace malfunctioning components.

## Component Inspection

INFOID:000000001675439

### 1.CHECK ACTIVE TEST

1. Select each test menu item on "ACTIVE TEST".
2. On the display, touch "UP", "KEEP", and "DOWN", and check that the system operates as shown in the table below.

Operation		ABS solenoid valve			ABS solenoid valve (ACT)		
		UP	KEEP	DOWN	UP	ACTUA-TOR UP	ACTUA-TOR KEEP
FR RH SOL FR RH ABS SOLE- NOID (ACT)	FR RH IN SOL	OFF	ON	ON	OFF	OFF	OFF
	FR RH OUT SOL	OFF	OFF	ON*	OFF	OFF	OFF
FR LH SOL FR LH ABS SOLE- NOID (ACT)	FR LH IN SOL	OFF	ON	ON	OFF	OFF	OFF
	FR LH OUT SOL	OFF	OFF	ON*	OFF	OFF	OFF
RR RH SOL RR RH ABS SOLE- NOID (ACT)	RR RH IN SOL	OFF	ON	ON	OFF	OFF	OFF
	RR RH OUT SOL	OFF	OFF	ON*	OFF	OFF	OFF
RR LH SOL RR LH ABS SOLE- NOID (ACT)	RR LH IN SOL	OFF	ON	ON	OFF	OFF	OFF
	RR LH OUT SOL	OFF	OFF	ON*	OFF	OFF	OFF
REAR SOL	RR RH IN SOL	OFF	ON	ON	OFF	OFF	OFF
	RR RH OUT SOL	OFF	OFF	ON*	OFF	OFF	OFF
	RR LH IN SOL	OFF	ON	ON	OFF	OFF	OFF
	RR LH OUT SOL	OFF	OFF	ON*	OFF	OFF	OFF

\*: ON for 1 to 2 seconds after the touch, and then OFF

Is the inspection result normal?

- YES >> INSPECTION END

## C1121, C1123, C1125, C1127 OUT ABS SOL

< COMPONENT DIAGNOSIS >

[VDC/TCS/ABS]

NO >> Go to diagnosis procedure. Refer to [BRC-192. "Diagnosis Procedure"](#).

### Special Repair Requirement

INFOID:000000001675440

#### 1.AJUSTMENT OF STEERING ANGLE SENSOR NEUTRAL POSITION

Always perform neutral position adjustment for the steering angle sensor when replacing the ABS actuator and electric unit (control unit). Refer to [BRC-150. "ADJUSTMENT OF STEERING ANGLE SENSOR NEUTRAL POSITION : Description"](#).

>> GO TO 2

#### 2.CALIBRATION OF DECEL G SENSOR

Always perform calibration of decel G sensor when replacing the ABS actuator and electric unit (control unit). Refer to [BRC-151. "CALIBRATION OF DECEL G SENSOR : Description"](#).

>> END

# C1130, C1131, C1132, C1133, C1136 ENGINE SIGNAL

< COMPONENT DIAGNOSIS >

[VDC/TCS/ABS]

## C1130, C1131, C1132, C1133, C1136 ENGINE SIGNAL

### Description

INFOID:000000001537192

ABS actuator and electric unit (control unit) and ECM exchange the engine signal with CAN communication line.

### DTC Logic

INFOID:000000001537193

### DTC DETECTION LOGIC

DTC	Display item	Malfunction detected condition	Possible cause
C1130	ENGINE SIGNAL 1	Based on the signal from ECM, ABS actuator and electric unit (control unit) judges that engine fuel cut system is malfunctioning.	<ul style="list-style-type: none"><li>• Harness or connector</li><li>• ABS actuator and electric unit (control unit)</li><li>• ECM</li><li>• CAN communication line</li></ul>
C1131	ENGINE SIGNAL 2		
C1132	ENGINE SIGNAL 3		
C1133	ENGINE SIGNAL 4		
C1136	ENGINE SIGNAL 6		

### DTC CONFIRMATION PROCEDURE

#### 1. CHECK SELF-DIAGNOSIS RESULTS

Check the self-diagnosis results.

Self-diagnosis results
ENGINE SIGNAL 1
ENGINE SIGNAL 2
ENGINE SIGNAL 3
ENGINE SIGNAL 4
ENGINE SIGNAL 6

Is above displayed on the self-diagnosis display?

- YES >> Proceed to diagnosis procedure. Refer to [BRC-195, "Diagnosis Procedure"](#).  
NO >> INSPECTION END

### Diagnosis Procedure

INFOID:000000001537194

### INSPECTION PROCEDURE

#### 1. CHECK ENGINE SYSTEM

1. Perform ECM self-diagnosis. Repair or replace items indicated, then perform ECM self-diagnosis again. Refer to [EC-67, "CONSULT-III Function \(ENGINE\)"](#).
2. Perform ABS actuator and electric unit (control unit) self-diagnosis. Refer to [BRC-165, "CONSULT-III Function \(ABS\)"](#).

Is any item indicated on the self-diagnosis display?

- YES >> Repair or replace the affected part.  
NO >> INSPECTION END

### Special Repair Requirement

INFOID:000000001675441

#### 1. ADJUSTMENT OF STEERING ANGLE SENSOR NEUTRAL POSITION

Always perform neutral position adjustment for the steering angle sensor when replacing the ABS actuator and electric unit (control unit). Refer to [BRC-150, "ADJUSTMENT OF STEERING ANGLE SENSOR NEUTRAL POSITION : Description"](#).

>> GO TO 2

## C1130, C1131, C1132, C1133, C1136 ENGINE SIGNAL

< COMPONENT DIAGNOSIS >

[VDC/TCS/ABS]

---

### 2. CALIBRATION OF DECEL G SENSOR

---

Always perform calibration of decel G sensor when replacing the ABS actuator and electric unit (control unit).  
Refer to [BRC-151, "CALIBRATION OF DECEL G SENSOR : Description"](#).

>> END

# C1140 ACTUATOR RLY

< COMPONENT DIAGNOSIS >

[VDC/TCS/ABS]

## C1140 ACTUATOR RLY

### Description

INFOID:000000001537196

Activates or deactivates each solenoid valve according to the signals transmitted by the ABS actuator and electric unit (control unit).

### DTC Logic

INFOID:000000001537197

#### DTC DETECTION LOGIC

DTC	Display item	Malfunction detected condition	Possible cause
C1140	ACTUATOR RLY	ABS actuator relay or circuit malfunction.	<ul style="list-style-type: none"> <li>Harness or connector</li> <li>ABS actuator and electric unit (control unit)</li> </ul>

#### DTC CONFIRMATION PROCEDURE

##### 1. CHECK SELF-DIAGNOSIS RESULTS

Check the self-diagnosis results.

Self-diagnosis results
ACTUATOR RLY

Is above displayed on the self-diagnosis display?

- YES >> Proceed to diagnosis procedure. Refer to [BRC-197, "Diagnosis Procedure"](#).  
 NO >> INSPECTION END

### Diagnosis Procedure

INFOID:000000001675442

#### INSPECTION PROCEDURE

##### 1. CHECK CONNECTOR

- Turn ignition switch OFF.
- Disconnect ABS actuator and electric unit (control unit) connector.
- Check terminal for deformation, disconnection, looseness, and so on. If any malfunction is found, repair or replace terminal.
- Reconnect connectors and then perform the self-diagnosis. Refer to [BRC-165, "CONSULT-III Function \(ABS\)"](#).

Is any item indicated on the self-diagnosis display?

- YES >> GO TO 2  
 NO >> Poor connection of connector terminal. Repair or replace connector.

##### 2. CHECK SOLENOID, VDC SWITCH-OVER VALVE AND ACTUATOR RELAY POWER SUPPLY CIRCUIT

- Turn ignition switch OFF.
- Disconnect ABS actuator and electric unit (control unit) connector.
- Check voltage between ABS actuator and electric unit (control unit) harness connector terminal and ground.

ABS actuator and electric unit (control unit)		—	Voltage
Connector	Terminal		
E125	32	Ground	Battery voltage

Is the inspection result normal?

- YES >> GO TO 3  
 NO >> Repair or replace malfunctioning components.

##### 3. CHECK SOLENOID, VDC SWITCH-OVER VALVE AND ACUATOR RELAY GROUND CIRCUIT

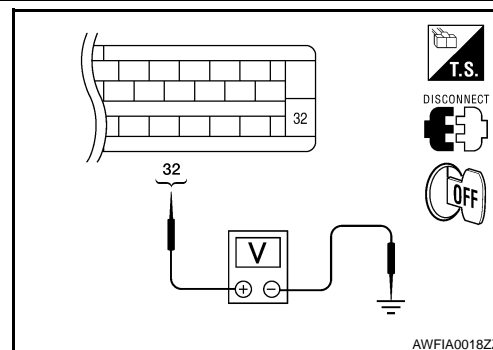

AWFIA0018ZZ

# C1140 ACTUATOR RLY

[VDC/TCS/ABS]

## < COMPONENT DIAGNOSIS >

Check continuity between ABS actuator and electric unit (control unit) harness connector terminals and ground.

ABS actuator and electric unit (control unit)		—	Continuity
Connector	Terminal		
E125	16, 47	Ground	Yes

Is the inspection result normal?

- YES >> Replace ABS actuator and electric unit (control unit).  
Refer to [BRC-255, "Removal and Installation"](#).
- NO >> Repair or replace malfunctioning components.

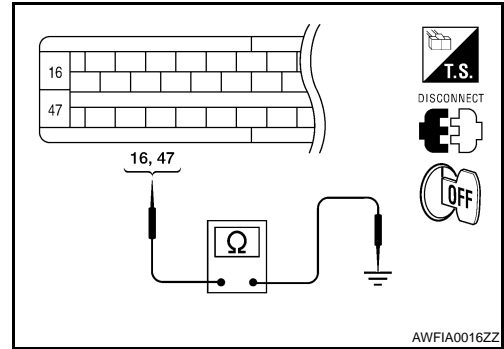

INFOID:000000001537199

## Component Inspection

### 1. CHECK ACTIVE TEST

- On "ACTIVE TEST", select "ABS MOTOR".
- Touch ON and OFF on screen. Make sure motor relay and actuator relay operates as shown in table below.

Operation	ON	OFF
MOTOR RELAY	ON	OFF
ACTUATOR RLY	ON	ON

Is the inspection result normal?

- YES >> INSPECTION END
- NO >> Go to diagnosis procedure. Refer to [BRC-197, "Diagnosis Procedure"](#).

## Special Repair Requirement

INFOID:000000001675443

### 1. ADJUSTMENT OF STEERING ANGLE SENSOR NEUTRAL POSITION

Always perform neutral position adjustment for the steering angle sensor when replacing the ABS actuator and electric unit (control unit). Refer to [BRC-150, "ADJUSTMENT OF STEERING ANGLE SENSOR NEUTRAL POSITION : Description"](#).

>> GO TO 2

### 2. CALIBRATION OF DECEL G SENSOR

Always perform calibration of decel G sensor when replacing the ABS actuator and electric unit (control unit). Refer to [BRC-151, "CALIBRATION OF DECEL G SENSOR : Description"](#).

>> END

# C1142 PRESS SENSOR

< COMPONENT DIAGNOSIS >

[VDC/TCS/ABS]

## C1142 PRESS SENSOR

### Description

INFOID:000000001537201

The front and rear pressure sensors convert the brake fluid pressure to an electric signal and transmit it to the ABS actuator and electric unit (control unit).

### DTC Logic

INFOID:000000001537202

#### DTC DETECTION LOGIC

DTC	Display item	Malfunction detected condition	Possible cause
C1142	PRESS SEN CIRCUIT	Pressure sensor signal line is open or shorted, or pressure sensor is malfunctioning.	<ul style="list-style-type: none"> <li>• Harness or connector</li> <li>• Pressure sensor</li> <li>• ABS actuator and electric unit (control unit)</li> </ul>

#### DTC CONFIRMATION PROCEDURE

##### 1. CHECK SELF-DIAGNOSIS RESULTS

Check the self-diagnosis results.

Self-diagnosis results
PRESS SEN CIRCUIT

Is above displayed on the self-diagnosis display?

- YES >> Proceed to diagnosis procedure. Refer to [BRC-199. "Diagnosis Procedure"](#).  
 NO >> INSPECTION END

### Diagnosis Procedure

INFOID:000000001537203

#### FRONT PRESSURE SENSOR INSPECTION PROCEDURE

##### 1. CONNECTOR INSPECTION

1. Turn the ignition switch OFF.
2. Disconnect the front pressure sensor connector E31 and ABS actuator and electric unit (control unit) connector E125 and inspect the terminals for deformation, disconnection, looseness, or damage.

Is the inspection result normal?

- YES >> GO TO 2  
 NO >> Repair connector.

##### 2. FRONT PRESSURE SENSOR CIRCUIT INSPECTION

1. Measure the continuity between the ABS actuator and electric unit (control unit) harness connector E125 (A) and front pressure sensor harness connector E31 (B).

ABS actuator and electric unit (control unit)		Front pressure sensor		Continuity
Connector	Terminal	Connector	Terminal	
A: E125	18	B: E31	3	Yes
	19		1	
	20		2	

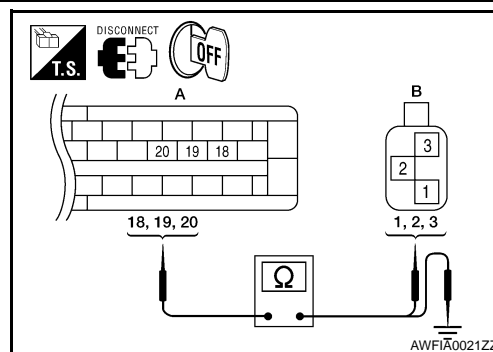

2. Measure the continuity between the ABS actuator and electric unit (control unit) harness connector E125 (A) and body ground.

# C1142 PRESS SENSOR

[VDC/TCS/ABS]

## < COMPONENT DIAGNOSIS >

ABS actuator and electric unit (control unit)		—	Continuity
Connector	Terminal		
A: E125	18	Ground	No
	19		
	20		

Is the inspection result normal?

YES >> GO TO 3

NO >> Repair or replace harness or connector.

### 3.FRONT PRESSURE SENSOR INSPECTION

1. Reconnect the front pressure sensor and ABS actuator and electric unit (control unit) connectors.
2. Use "DATA MONITOR" to check if the status of "PRESS SENSOR" is normal.

Condition	PRESS SENSOR (DATA MONITOR)
With ignition switch turned ON and brake pedal released.	Approx. 0 bar
With ignition switch turned ON and brake pedal depressed.	Positive value

Is the inspection result normal?

YES >> Inspection End.

NO >> Replace the front pressure sensor.

### REAR PRESSURE SENSOR INSPECTION PROCEDURE

#### 1.CONNECTOR INSPECTION

1. Turn the ignition switch OFF.
2. Disconnect the rear pressure sensor connector E32 and ABS actuator and electric unit (control unit) connector E125 and inspect the terminals for deformation, disconnection, looseness, or damage.

Is the inspection result normal?

YES >> GO TO 2

NO >> Repair connector.

#### 2.REAR PRESSURE SENSOR CIRCUIT INSPECTION

1. Measure the continuity between the ABS actuator and electric unit (control unit) harness connector E125 (A) and rear pressure sensor harness connector E32 (B).

ABS actuator and electric unit (control unit)		Rear pressure sensor		Continuity
Connector	Terminal	Connector	Terminal	
A: E125	21	B: E32	1	Yes
	22		3	
	23		2	

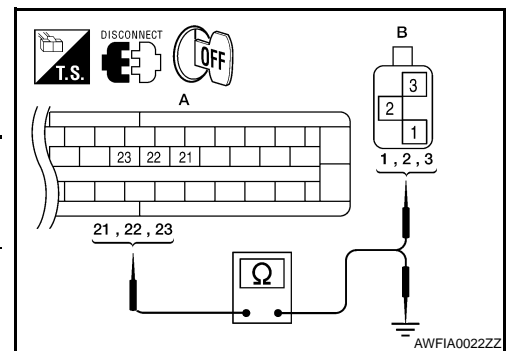

2. Measure the continuity between the ABS actuator and electric unit (control unit) harness connector E125 (A) and body ground.

ABS actuator and electric unit (control unit)		—	Continuity
Connector	Terminal		
A: E125	21	Ground	No
	22		
	23		



# C1142 PRESS SENSOR

[VDC/TCS/ABS]

< COMPONENT DIAGNOSIS >

Is the inspection result normal?

- YES >> GO TO 3
- NO >> Repair or replace harness or connector.

## 3. REAR PRESSURE SENSOR INSPECTION

1. Reconnect the rear pressure sensor and ABS actuator and electric unit (control unit) connectors.
2. Use "DATA MONITOR" to check if the status of "PRESS SEN2" is normal.

Condition	PRESS SEN2 (DATA MONITOR)
With ignition switch turned ON and brake pedal released.	Approx. 0 bar
With ignition switch turned ON and brake pedal depressed.	Positive value

Is the inspection result normal?

- YES >> Inspection End.
- NO >> Replace the rear pressure sensor.

## Component Inspection

INFOID:000000001537204

BRC

### 1. CHECK DATA MONITOR

On "DATA MONITOR", select "PRESS SENSOR" and "PRESS SEN2" and check the brake fluid pressure.

Condition	PRESS SENSOR and PRESS SEN2 (DATA MONITOR)
With ignition switch turned ON and brake pedal released.	Approx. 0 bar
With ignition switch turned ON and brake pedal depressed.	Positive value

Is the inspection result normal?

- YES >> INSPECTION END
- NO >> Go to diagnosis procedure. Refer to [BRC-199, "Diagnosis Procedure"](#).

## Special Repair Requirement

INFOID:000000001675444

### 1. ADJUSTMENT OF STEERING ANGLE SENSOR NEUTRAL POSITION

Always perform neutral position adjustment for the steering angle sensor when replacing the ABS actuator and electric unit (control unit). Refer to [BRC-150, "ADJUSTMENT OF STEERING ANGLE SENSOR NEUTRAL POSITION : Description"](#).

>> GO TO 2

### 2. CALIBRATION OF DECEL G SENSOR

Always perform calibration of decel G sensor when replacing the ABS actuator and electric unit (control unit). Refer to [BRC-151, "CALIBRATION OF DECEL G SENSOR : Description"](#).

>> END

# C1143, C1144 STEERING ANGLE SENSOR

< COMPONENT DIAGNOSIS >

[VDC/TCS/ABS]

## C1143, C1144 STEERING ANGLE SENSOR

### Description

INFOID:000000001537206

The steering angle sensor detects the rotation amount, angular velocity and direction of the steering wheel, and transmits the data to the ABS actuator and electric unit (control unit) via CAN communication.

### DTC Logic

INFOID:000000001537207

### DTC DETECTION LOGIC

DTC	Display item	Malfunction detected condition	Possible cause
C1143	ST ANG SEN CIRCUIT	Neutral position of steering angle sensor is dislocated, or the steering angle sensor is malfunctioning.	<ul style="list-style-type: none"><li>• Harness or connector</li><li>• Steering angle sensor</li><li>• 4WAS control unit (4WAS models)</li><li>• ABS actuator and electric unit (control unit)</li></ul>
C1144	ST ANG SEN SIGNAL	Neutral position of steering angle sensor is not finished.	

### DTC CONFIRMATION PROCEDURE

#### 1.CHECK SELF-DIAGNOSIS RESULTS

Check the self-diagnosis results.

Self-diagnosis results
ST ANG SEN CIRCUIT
ST ANG SEN SIGNAL

Is above displayed on the self-diagnosis display?

- YES >> Proceed to diagnosis procedure. Refer to [BRC-202. "Diagnosis Procedure"](#).  
NO >> INSPECTION END

### Diagnosis Procedure

INFOID:000000001537208

### INSPECTION PROCEDURE

#### 1.CHECK CONNECTOR

1. Turn ignition switch OFF.
2. Disconnect ABS actuator and electric unit (control unit) connector.
3. Disconnect steering angle sensor connector.
4. Check terminal for deformation, disconnection, looseness, and so on. If any malfunction is found, repair or replace terminal.
5. Reconnect connectors and then perform the self-diagnosis. Refer to [BRC-165. "CONSULT-III Function \(ABS\)"](#)

Is any item indicated on the self-diagnosis display?

- YES >> GO TO 2  
NO >> Poor connection of connector terminal. Repair or replace connector.

#### 2.CHECK STEERING ANGLE SENSOR HARNESS

1. Turn ignition switch OFF.
2. Disconnect steering angle sensor connector.

# C1143, C1144 STEERING ANGLE SENSOR

[VDC/TCS/ABS]

## < COMPONENT DIAGNOSIS >

3. Check continuity between steering angle sensor harness connector terminal and ground.

Steering angle sensor		—	Continuity
Connector	Terminal		
M47	2	Ground	Yes

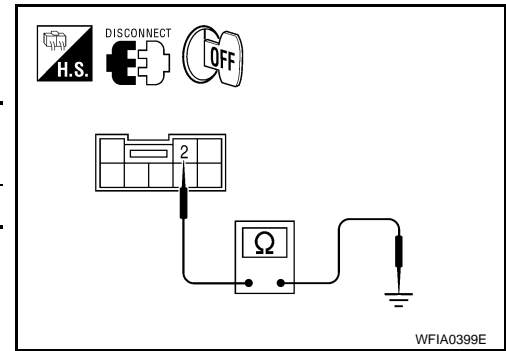

4. Turn ignition switch ON.
5. Check voltage between steering angle sensor harness connector terminal and ground.

Steering angle sensor		—	Voltage
Connector	Terminal		
M47	3	Ground	Battery voltage

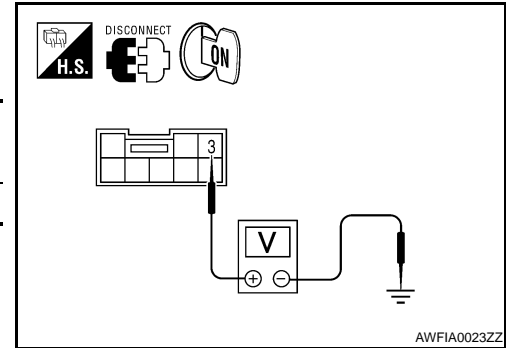

Is the inspection result normal?

- YES >> GO TO 3  
 NO >> Repair or replace malfunctioning components.

### 3.CHECK DATA MONITOR

1. Connect the steering angle sensor connector and ABS actuator and electric unit (control unit) connector.
2. Select "STR ANGLE SIG" in "DATA MONITOR" and check steering angle sensor signal.

Steering condition	STR ANGLE SIG (DATA MONITOR)
Driving straight	$\pm 2.5^\circ$
Turn 90° to right	Approx. +90°
Turn 90° to left	Approx. -90°

Is the inspection result normal?

- YES >> Replace ABS actuator and electric unit (control unit). Refer to [BRC-255. "Removal and Installation"](#).  
 NO >> Replace steering angle sensor and adjust neutral position of steering angle sensor. Refer to [BRC-257. "Removal and Installation"](#).

## Component Inspection

INFOID:000000001537209

### 1.CHECK DATA MONITOR

Select "STR ANGLE SIG" in "DATA MONITOR" and check steering angle sensor signal.

Steering condition	STR ANGLE SIG (DATA MONITOR)
Driving straight	$\pm 2.5^\circ$
Turn 90° to right	Approx. +90°
Turn 90° to left	Approx. -90°

Is the inspection result normal?

- YES >> INSPECTION END  
 NO >> Go to diagnosis procedure. Refer to [BRC-202. "Diagnosis Procedure"](#).

## Special Repair Requirement

INFOID:000000001675445

### 1.AJUSTMENT OF STEERING ANGLE SENSOR NEUTRAL POSITION

## C1143, C1144 STEERING ANGLE SENSOR

[VDC/TCS/ABS]

< COMPONENT DIAGNOSIS >

Always perform neutral position adjustment for the steering angle sensor when replacing the ABS actuator and electric unit (control unit). Refer to [BRC-150, "ADJUSTMENT OF STEERING ANGLE SENSOR NEUTRAL POSITION : Description"](#).

>> GO TO 2

### 2. CALIBRATION OF DECEL G SENSOR

Always perform calibration of decel G sensor when replacing the ABS actuator and electric unit (control unit). Refer to [BRC-151, "CALIBRATION OF DECEL G SENSOR : Description"](#).

>> END

# C1155 BRAKE FLUID LEVEL SWITCH

< COMPONENT DIAGNOSIS >

[VDC/TCS/ABS]

## C1155 BRAKE FLUID LEVEL SWITCH

### Description

INFOID:000000001537211

The brake fluid level switch converts the brake fluid level to an electric signal and transmits it to the ABS actuator and electric unit (control unit).

### DTC Logic

INFOID:000000001537212

### DTC DETECTION LOGIC

DTC	Display item	Malfunction detected condition	Possible cause
C1155	BR FLUID LEVEL LOW	Brake fluid level is low or communication line between the ABS actuator and electric unit (control unit) and brake fluid level switch is open or shorted.	<ul style="list-style-type: none"> <li>• Harness or connector</li> <li>• Brake fluid level switch</li> <li>• Brake fluid level</li> </ul>

### DTC CONFIRMATION PROCEDURE

#### 1. CHECK SELF-DIAGNOSIS RESULTS

Check the self-diagnosis results.

Self-diagnosis results
BR FLUID LEVEL LOW

Is above displayed on the self-diagnosis display?

- YES >> Proceed to diagnosis procedure. Refer to [BRC-205. "Diagnosis Procedure"](#).  
 NO >> INSPECTION END

### Diagnosis Procedure

INFOID:000000001537213

### INSPECTION PROCEDURE

#### 1. CONNECTOR INSPECTION

1. Disconnect ABS actuator and electric unit (control unit) connector E125 and brake fluid level switch connector E21.
2. Check the terminals for deformation, disconnection, looseness or damage.

Is the inspection result normal?

- YES >> GO TO 2  
 NO >> Repair or replace as necessary.

#### 2. CHECK HARNESS BETWEEN BRAKE FLUID LEVEL SWITCH AND ABS ACTUATOR AND ELECTRIC UNIT (CONTROL UNIT)

1. Check continuity between ABS actuator and electric unit (control unit) harness connector E125 (A) and brake fluid level switch harness connector E21 (B).

ABS actuator and electric unit (control unit)		Brake fluid level switch		Continuity
Connector	Terminal	Connector	Terminal	
A: E125	8	B: E21	1	Yes

2. Check continuity between ABS actuator and electric unit (control unit) harness connector E125 (A) and ground.

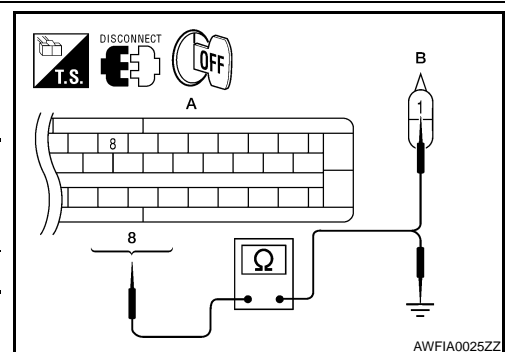

ABS actuator and electric unit (control unit)		—	Continuity
Connector	Terminal		
A: E125	8	Ground	No

Is the inspection result normal?

# C1155 BRAKE FLUID LEVEL SWITCH

[VDC/TCS/ABS]

## < COMPONENT DIAGNOSIS >

- YES >> GO TO 3
- NO >> Repair or replace malfunctioning components.

### 3.CHECK BRAKE FLUID LEVEL SWITCH GROUND

Check continuity between brake fluid level switch harness connector E21 and ground.

Brake fluid level switch		—	Continuity
Connector	Terminal		
E21	2	Ground	Yes

Is the inspection result normal?

- YES >> GO TO 4
- NO >> Repair or replace malfunctioning components.

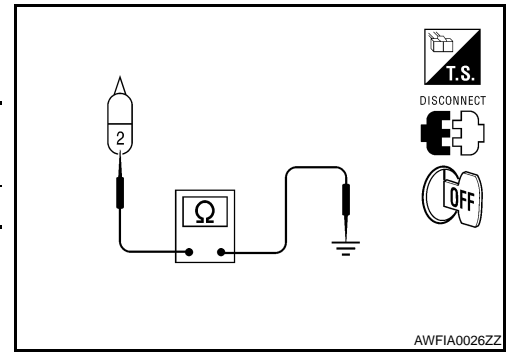

### 4.CHECK BRAKE FLUID LEVEL SWITCH

Check continuity between brake fluid level switch terminals.

Brake fluid level switch		Condition	Continuity
Terminal			
1 - 2		When brake fluid is full in the reservoir tank.	No
		When brake fluid is empty in the reservoir tank.	Yes

Is the inspection result normal?

- YES >> Perform self-diagnosis again. If the same results appear, replace ABS actuator and electric unit (control unit). Refer to [BRC-255, "Removal and Installation"](#).
- NO >> Replace brake fluid level switch.

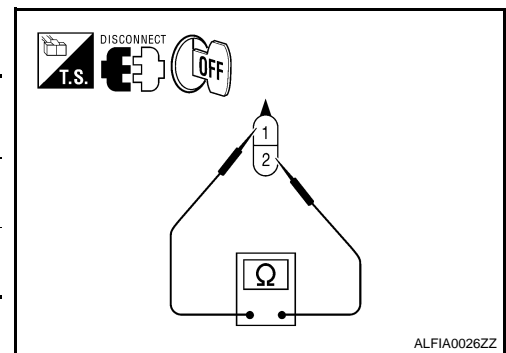

## Component Inspection

INFOID:000000001537214

### 1.CHECK BRAKE FLUID LEVEL SWITCH

1. Turn ignition switch OFF.
2. Disconnect brake fluid level switch connector.
3. Check continuity between brake fluid level switch terminals.

Brake fluid level switch		Condition	Continuity
Terminal			
1 - 2		When brake fluid is full in the reservoir tank.	No
		When brake fluid is empty in the reservoir tank.	Yes

Is the inspection result normal?

- YES >> INSPECTION END
- NO >> Replace brake fluid level switch.

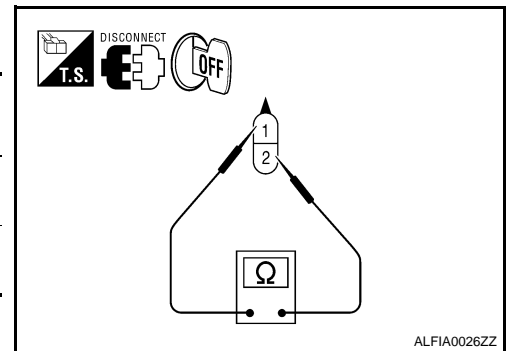

## Special Repair Requirement

INFOID:000000001675446

### 1.AJUSTMENT OF STEERING ANGLE SENSOR NEUTRAL POSITION

Always perform neutral position adjustment for the steering angle sensor when replacing the ABS actuator and electric unit (control unit). Refer to [BRC-150, "ADJUSTMENT OF STEERING ANGLE SENSOR NEUTRAL POSITION : Description"](#).

# C1155 BRAKE FLUID LEVEL SWITCH

< COMPONENT DIAGNOSIS >

[VDC/TCS/ABS]

>> GO TO 2

## 2. CALIBRATION OF DECEL G SENSOR

Always perform calibration of decel G sensor when replacing the ABS actuator and electric unit (control unit).  
Refer to [BRC-151. "CALIBRATION OF DECEL G SENSOR : Description"](#).

>> END

A

B

C

D

E

**BRC**

G

H

I

J

K

L

M

N

O

P

## C1156 ST ANG SEN COM CIR

### Description

INFOID:000000001537216

The steering angle sensor is connected to the ABS actuator and electric unit (control unit) in addition to CAN lines. CAN (Controller Area Network) is a serial communication line for real time application. It is an on-vehicle multiplex communication line with high data communication speed and excellent error detection ability. Many electronic control units are equipped onto a vehicle, and each control unit shares information and links with other control units during operation (not independent). In CAN communication, control units are connected with 2 communication lines (CAN H line, CAN L line) allowing a high rate of information transmission with less wiring. Each control unit transmits/receives data but selectively reads required data only.

### DTC Logic

INFOID:000000001537217

### DTC DETECTION LOGIC

DTC	Display item	Malfunction detected condition	Possible cause
C1156	ST ANG SEN COM CIR	When steering angle sensor is not transmitting CAN communication signal to the ABS actuator and electric unit (control unit).	<ul style="list-style-type: none"> <li>• Harness or connector</li> <li>• CAN communication line</li> <li>• Steering angle sensor</li> <li>• ABS actuator and electric unit (control unit)</li> </ul>

### DTC CONFIRMATION PROCEDURE

#### 1. CHECK SELF-DIAGNOSIS RESULTS

Check the self-diagnosis results.

Self-diagnosis results
ST ANG SEN COM CIR

Is above displayed on the self-diagnosis display?

- YES >> Proceed to diagnosis procedure. Refer to [BRC-208, "Diagnosis Procedure"](#).  
 NO >> INSPECTION END

### Diagnosis Procedure

INFOID:000000001537218

### INSPECTION PROCEDURE

#### 1. CHECK CONNECTOR

1. Turn ignition switch OFF and disconnect ABS actuator and electric unit (control unit) connector E125, check terminal for deformation, disconnection, looseness, and so on. If any malfunction is found, repair or replace terminal.
2. Reconnect connector and perform self-diagnosis.

Self-diagnosis results
CAN COMM CIRCUIT
ST ANG SEN COM CIR

Is above displayed on the self-diagnosis display?

- YES >> Refer to [LAN-14, "Trouble Diagnosis Flow Chart"](#).  
 NO >> INSPECTION END



# C1160 DECEL G SEN SET

< COMPONENT DIAGNOSIS >

[VDC/TCS/ABS]

## C1160 DECEL G SEN SET

### Description

INFOID:000000001537219

The yaw rate/side/decel G sensor detects the yaw rate/side/decel G affecting the vehicle, and transmits the data to the ABS actuator and electric unit (control unit) as an analog voltage signal.

### DTC Logic

INFOID:000000001537220

### DTC DETECTION LOGIC

DTC	Display item	Malfunction detected condition	Possible cause
C1160	DECEL G SEN SET	ABS decel G sensor adjustment is incomplete.	<ul style="list-style-type: none"><li>Decel G sensor calibration</li><li>Yaw rate/side/decel G sensor</li><li>ABS actuator and electric unit (control unit)</li></ul>

### DTC CONFIRMATION PROCEDURE

#### 1. CHECK SELF-DIAGNOSIS RESULTS

Check the self-diagnosis results.

Self-diagnosis results
DECEL G SEN SET

Is above displayed on the self-diagnosis display?

- YES >> Proceed to diagnosis procedure. Refer to [BRC-209, "Diagnosis Procedure"](#).  
NO >> INSPECTION END

### Diagnosis Procedure

INFOID:000000001537221

### INSPECTION PROCEDURE

#### 1. PERFORM SELF-DIAGNOSIS

Perform ABS actuator and electric unit (control unit) self-diagnosis.

Self-diagnosis results
DECEL G SEN SET

Do self-diagnosis results indicate anything other than shown above?

- YES >> Perform repair or replacement for the item indicated.  
NO >> Perform calibration of decel G sensor. Refer to [BRC-151, "CALIBRATION OF DECEL G SENSOR : Description"](#). GO TO 2

#### 2. PERFORM SELF-DIAGNOSIS AGAIN

- Turn the ignition switch to OFF and then to ON and erase self-diagnosis results.
- Perform ABS actuator and electric unit (control unit) self-diagnosis again.

Are any self-diagnosis results displayed?

- YES >> Replace yaw rate/side/decel G sensor. Refer to [BRC-258, "Removal and Installation"](#).  
NO >> INSPECTION END

**C1163 ST ANGLE SEN SAFE**

**Description**

INFOID:000000001537222

The steering angle sensor detects the rotation amount, angular velocity and direction of the steering wheel, and transmits the data to the ABS actuator and electric unit (control unit) via CAN communication.

**DTC Logic**

INFOID:000000001537223

**DTC DETECTION LOGIC**

DTC	Display item	Malfunction detected condition	Possible cause
C1163	ST ANGL SEN SAFE	When steering angle sensor is in safe mode.	<ul style="list-style-type: none"> <li>Adjust steering angle sensor neutral position</li> </ul>

**DTC CONFIRMATION PROCEDURE**

**1.CHECK SELF-DIAGNOSIS RESULTS**

Check the self-diagnosis results.

Self-diagnosis results
ST ANGL SEN SAFE

Is above displayed on the self-diagnosis display?

- YES >> Proceed to diagnosis procedure. Refer to [BRC-210, "Diagnosis Procedure"](#).
- NO >> INSPECTION END

**Diagnosis Procedure**

INFOID:000000001537224

**INSPECTION PROCEDURE**

**1.ADJUSTMENT OF STEERING ANGLE SENSOR NEUTRAL POSITION**

Adjust steering angle sensor neutral position. Refer to [BRC-150, "ADJUSTMENT OF STEERING ANGLE SENSOR NEUTRAL POSITION : Description"](#).

>> GO TO 2

**2.INDICATOR LAMP CHECK**

Check that VDC OFF indicator lamp is off.

Is VDC OFF indicator lamp off?

- YES >> INSPECTION END
- NO >> Perform ABS actuator and electric unit (control unit) self-diagnosis. Refer to [BRC-165, "CONSULT-III Function \(ABS\)"](#).

# C1164, C1165, C1166, C1167 CV/SV SYSTEM

< COMPONENT DIAGNOSIS >

[VDC/TCS/ABS]

## C1164, C1165, C1166, C1167 CV/SV SYSTEM

### Description

INFOID:000000001537225

#### CV1, CV2 (CUT VALVE)

The cut valve shuts off the normal brake fluid path from the master cylinder, when VDC/TCS is activated.

#### SV1, SV2 (SUCTION VALVE)

The suction valve supplies the brake fluid from the master cylinder to the pump, when VDC/TCS is activated.

### DTC Logic

INFOID:000000001537226

### DTC DETECTION LOGIC

DTC	Display item	Malfunction detected condition	Possible cause
C1164	CV1	VDC switch-over solenoid valve (CV1) on the primary side is open circuit or shorted, or the control line is open or shorted to the power supply or the ground.	<ul style="list-style-type: none"><li>• Harness or connector</li><li>• ABS actuator and electric unit (control unit)</li></ul>
C1165	CV2	VDC switch-over solenoid valve (CV2) on the primary side is open circuit or shorted, or the control line is open or shorted to the power supply or the ground.	
C1166	SV1	VDC switch-over solenoid valve (SV1) on the primary side is open circuit or shorted, or the control line is open or shorted to the power supply or the ground.	
C1167	SV2	VDC switch-over solenoid valve (SV2) on the primary side is open circuit or shorted, or the control line is open or shorted to the power supply or the ground.	

### DTC CONFIRMATION PROCEDURE

#### 1. CHECK SELF-DIAGNOSIS RESULTS

Check the self-diagnosis results.

Self-diagnosis results
CV1
CV2
SV1
SV2

Is above displayed on the self-diagnosis display?

- YES >> Proceed to diagnosis procedure. Refer to [BRC-211. "Diagnosis Procedure"](#).  
NO >> INSPECTION END

### Diagnosis Procedure

INFOID:000000001675447

### INSPECTION PROCEDURE

#### 1. CHECK CONNECTOR

1. Turn ignition switch OFF.
2. Disconnect ABS actuator and electric unit (control unit) connector.
3. Check terminal for deformation, disconnection, looseness, and so on. If any malfunction is found, repair or replace terminal.
4. Reconnect connectors and then perform the self-diagnosis. Refer to [BRC-165. "CONSULT-III Function \(ABS\)"](#).

Is any item indicated on the self-diagnosis display?

- YES >> GO TO 2  
NO >> Poor connection of connector terminal. Repair or replace connector.

# C1164, C1165, C1166, C1167 CV/SV SYSTEM

< COMPONENT DIAGNOSIS >

[VDC/TCS/ABS]

## 2. CHECK SOLENOID, VDC SWITCH-OVER VALVE AND ACTUATOR RELAY POWER SUPPLY CIRCUIT

1. Turn ignition switch OFF.
2. Disconnect ABS actuator and electric unit (control unit) connector.
3. Check voltage between ABS actuator and electric unit (control unit) harness connector terminal and ground.

ABS actuator and electric unit (control unit)		—	Voltage
Connector	Terminal		
E125	32	Ground	Battery voltage

Is the inspection result normal?

- YES >> GO TO 3  
 NO >> Repair or replace malfunctioning components.

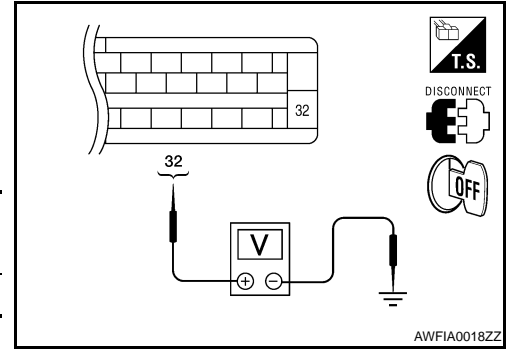

## 3. CHECK SOLENOID, VDC SWITCH-OVER VALVE AND ACUATOR RELAY GROUND CIRCUIT

Check continuity between ABS actuator and electric unit (control unit) harness connector terminals and ground.

ABS actuator and electric unit (control unit)		—	Continuity
Connector	Terminal		
E125	16, 47	Ground	Yes

Is the inspection result normal?

- YES >> Replace ABS actuator and electric unit (control unit).  
 Refer to [BRC-255, "Removal and Installation"](#).  
 NO >> Repair or replace malfunctioning components.

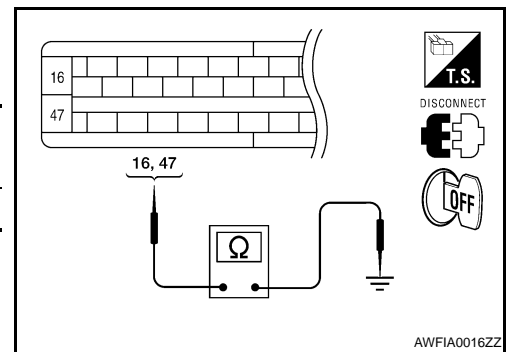

## Component Inspection

INFOID:000000001675448

### 1. CHECK ACTIVE TEST

1. Select each test menu item on "ACTIVE TEST".
2. On the display, touch "UP", "KEEP", and "DOWN", and check that the system operates as shown in the table below.

Operation		ABS solenoid valve			ABS solenoid valve (ACT)		
		UP	KEEP	DOWN	UP	ACTUA-TOR UP	ACTUA-TOR KEEP
FR RH SOL FR RH ABS SOLE- NOID (ACT)	FR RH IN SOL	OFF	ON	ON	OFF	OFF	OFF
	FR RH OUT SOL	OFF	OFF	ON*	OFF	OFF	OFF
FR LH SOL FR LH ABS SOLE- NOID (ACT)	FR LH IN SOL	OFF	ON	ON	OFF	OFF	OFF
	FR LH OUT SOL	OFF	OFF	ON*	OFF	OFF	OFF
RR RH SOL RR RH ABS SOLE- NOID (ACT)	RR RH IN SOL	OFF	ON	ON	OFF	OFF	OFF
	RR RH OUT SOL	OFF	OFF	ON*	OFF	OFF	OFF
RR LH SOL RR LH ABS SOLE- NOID (ACT)	RR LH IN SOL	OFF	ON	ON	OFF	OFF	OFF
	RR LH OUT SOL	OFF	OFF	ON*	OFF	OFF	OFF
REAR SOL	RR RH IN SOL	OFF	ON	ON	OFF	OFF	OFF
	RR RH OUT SOL	OFF	OFF	ON*	OFF	OFF	OFF
	RR LH IN SOL	OFF	ON	ON	OFF	OFF	OFF
	RR LH OUT SOL	OFF	OFF	ON*	OFF	OFF	OFF

\*: ON for 1 to 2 seconds after the touch, and then OFF

# C1164, C1165, C1166, C1167 CV/SV SYSTEM

< COMPONENT DIAGNOSIS >

[VDC/TCS/ABS]

Is the inspection result normal?

YES >> INSPECTION END

NO >> Go to diagnosis procedure. Refer to [BRC-211, "Diagnosis Procedure"](#).

Special Repair Requirement

INFOID:000000001675449

## 1. ADJUSTMENT OF STEERING ANGLE SENSOR NEUTRAL POSITION

Always perform neutral position adjustment for the steering angle sensor when replacing the ABS actuator and electric unit (control unit). Refer to [BRC-150, "ADJUSTMENT OF STEERING ANGLE SENSOR NEUTRAL POSITION : Description"](#).

>> GO TO 2

## 2. CALIBRATION OF DECEL G SENSOR

Always perform calibration of decel G sensor when replacing the ABS actuator and electric unit (control unit). Refer to [BRC-151, "CALIBRATION OF DECEL G SENSOR : Description"](#).

>> END

A  
B  
C  
D  
E  
BRC  
G  
H  
I  
J  
K  
L  
M  
N  
O  
P

# C1178, C1181, C1184, C1189 ABS ACTIVE BOOSTER

< COMPONENT DIAGNOSIS >

[VDC/TCS/ABS]

## C1178, C1181, C1184, C1189 ABS ACTIVE BOOSTER

### Description

INFOID:000000001537230

The active brake booster consists of a vacuum booster, an active booster control group and a delta stroke sensor. If a brake booster system malfunction occurs due to loss of vacuum, the delta stroke sensor will signal the ABS actuator and electric unit (control unit) that a booster malfunction has occurred. The active booster then applies supplemental force to the master cylinder relative to the amount of force exerted on the brake pedal.

### DTC Logic

INFOID:000000001537231

### DTC DETECTION LOGIC

DTC	Display item	Malfunction detected condition	Possible cause
C1178	ABS ACTIVE BOOSTER SV NG	Active booster solenoid is malfunctioning, or signal line of active booster servo is open or shorted.	<ul style="list-style-type: none"><li>• Harness or connector</li><li>• Active booster</li><li>• ABS actuator and electric unit (control unit)</li></ul>
C1181	ABS ACTIVE BOOSTER RESPONSE NG	Active booster response is malfunctioning, or signal line of active booster response is open or shorted.	
C1184	ABS BRAKE RELEASE SW NG	Brake release switch is malfunctioning, or signal line of brake release switch is open or shorted.	
C1189	ABS BRAKE BOOSTER DEFECT	Brake booster is defective or malfunctioning.	

### DTC CONFIRMATION PROCEDURE

#### 1. CHECK SELF-DIAGNOSIS RESULTS

Check the self-diagnosis results.

Self-diagnosis results
ABS ACTIVE BOOSTER SV NG
ABS ACTIVE BOOSTER RESPONSE NG
ABS BRAKE RELEASE SW NG
ABS BRAKE BOOSTER DEFECT

Is above displayed on the self-diagnosis display?

- YES >> Proceed to diagnosis procedure. Refer to [BRC-214, "Diagnosis Procedure"](#).  
NO >> INSPECTION END

### Diagnosis Procedure

INFOID:000000001537232

### INSPECTION PROCEDURE

#### 1. CONNECTOR INSPECTION

1. Turn the ignition switch OFF.
2. Disconnect the active booster connector E49 and ABS actuator and electric unit (control unit) connector E125 and inspect the terminals for deformation, disconnection, looseness, or damage.

Is the inspection result normal?

- YES >> GO TO 2  
NO >> Repair connector.

#### 2. ACTIVE BOOSTER CIRCUIT INSPECTION

# C1178, C1181, C1184, C1189 ABS ACTIVE BOOSTER

## < COMPONENT DIAGNOSIS >

[VDC/TCS/ABS]

1. Measure the continuity between ABS actuator and electric unit (control unit) harness connector E125 (A) and active booster harness connector E49 (B).

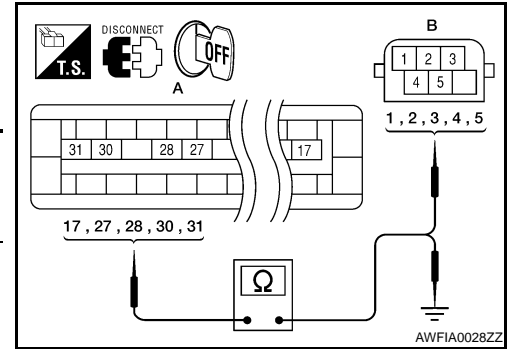

ABS actuator and electric unit (control unit)		Active booster		Continuity
Connector	Terminal	Connector	Terminal	
A: E125	17	B: E49	3	Yes
	27		1	
	28		5	
	30		2	
	31		4	

2. Measure the continuity between ABS actuator and electric unit (control unit) harness connector E125 (A) and body ground.

ABS actuator and electric unit (control unit)		—	Continuity
Connector	Terminal		
A: E125	17	Ground	No
	27		
	28		
	30		
	31		

Is the inspection result normal?

YES >> GO TO 3

NO >> Repair or replace harness or connector.

### 3.ACTIVE BOOSTER INSPECTION

1. Reconnect the active booster and ABS actuator and electric unit (control unit) connectors.
2. Use "DATA MONITOR" to check if the status of "RELEASE SWITCH NO" and "RELEASE SWITCH NC" is normal.

Condition	RELEASE SWITCH NO (DATA MONITOR)	RELEASE SWITCH NC (DATA MONITOR)
When brake pedal is depressed.	ON	OFF
When brake pedal is released.	OFF	ON

Is the inspection result normal?

YES >> Replace the ABS actuator and electric unit (control unit). Refer to [BRC-255, "Removal and Installation"](#).

NO >> Replace the active booster. Refer to [BR-30, "With VDC"](#).

### Component Inspection

INFOID:000000001537233

#### 1.CHECK DATA MONITOR

Use "DATA MONITOR" to check if the status of "RELEASE SWITCH NO" and "RELEASE SWITCH NC" is normal.

Condition	RELEASE SWITCH NO (DATA MONITOR)	RELEASE SWITCH NC (DATA MONITOR)
When brake pedal is depressed.	ON	OFF
When brake pedal is released.	OFF	ON

# C1178, C1181, C1184, C1189 ABS ACTIVE BOOSTER

< COMPONENT DIAGNOSIS >

[VDC/TCS/ABS]

Is the inspection result normal?

YES >> INSPECTION END

NO >> Go to diagnosis procedure. Refer to [BRC-214, "Diagnosis Procedure"](#).

## Special Repair Requirement

INFOID:000000001675450

### 1.AJUSTMENT OF STEERING ANGLE SENSOR NEUTRAL POSITION

Always perform neutral position adjustment for the steering angle sensor when replacing the ABS actuator and electric unit (control unit). Refer to [BRC-150, "ADJUSTMENT OF STEERING ANGLE SENSOR NEUTRAL POSITION : Description"](#).

>> GO TO 2

### 2.CALIBRATION OF DECEL G SENSOR

Always perform calibration of decel G sensor when replacing the ABS actuator and electric unit (control unit). Refer to [BRC-151, "CALIBRATION OF DECEL G SENSOR : Description"](#).

>> END



C1179 ABS DELTA S SEN NG

Description

INFOID:000000001537235

The active brake booster consists of a vacuum booster, an active booster control group and a delta stroke sensor. If a brake booster system malfunction occurs due to loss of vacuum, the delta stroke sensor will signal the ABS actuator and electric unit (control unit) that a booster malfunction has occurred. The active booster then applies supplemental force to the master cylinder relative to the amount of force exerted on the brake pedal.

DTC Logic

INFOID:000000001537236

DTC DETECTION LOGIC

DTC	Display item	Malfunction detected condition	Possible cause
C1179	ABS DELTA S SEN NG	Delta stroke sensor is malfunctioning, or signal line of delta stroke sensor is open or shorted.	<ul style="list-style-type: none"> <li>• Harness or connector</li> <li>• Delta stroke sensor</li> <li>• ABS actuator and electric unit (control unit)</li> </ul>

BRC

DTC CONFIRMATION PROCEDURE

1.CHECK SELF-DIAGNOSIS RESULTS

Check the self-diagnosis results.

Self-diagnosis results
ABS DELTA S SEN NG

Is above displayed on the self-diagnosis display?

- YES >> Proceed to diagnosis procedure. Refer to [BRC-217. "Diagnosis Procedure"](#).
- NO >> INSPECTION END

Diagnosis Procedure

INFOID:000000001537237

INSPECTION PROCEDURE

1.CONNECTOR INSPECTION

1. Turn the ignition switch OFF.
2. Disconnect the delta stroke sensor connector E114 and ABS actuator and electric unit (control unit) connector E125 and inspect the terminals for deformation, disconnection, looseness, or damage.

Is the inspection result normal?

- YES >> GO TO 2
- NO >> Repair connector.

2.DELTA STROKE SENSOR CIRCUIT INSPECTION

1. Measure the continuity between ABS actuator and electric unit (control unit) harness connector E125 (A) and delta stroke sensor harness connector E114 (B).

ABS actuator and electric unit (control unit)		Delta stroke sensor		Continuity
Connector	Terminal	Connector	Terminal	
A: E125	26	B: E114	1	Yes
	39		3	
	40		5	

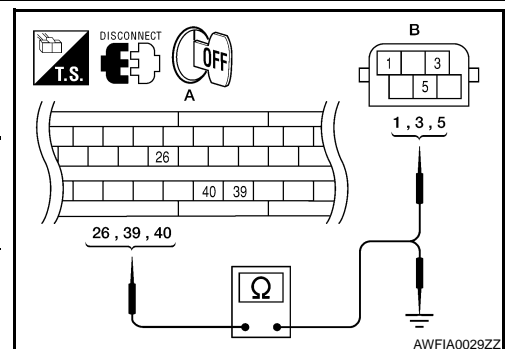

2. Measure the continuity between ABS actuator and electric unit (control unit) harness connector E125 (A) and body ground.

< COMPONENT DIAGNOSIS >

ABS actuator and electric unit (control unit)		—	Continuity
Connector	Terminal		
A: E125	26	Ground	No
	39		
	40		

Is the inspection result normal?

YES >> GO TO 3

NO >> Repair or replace harness or connector.

### 3.DELTA STROKE SENSOR INSPECTION

1. Reconnect the delta stroke sensor and ABS actuator and electric unit (control unit) connectors.
2. Use "DATA MONITOR" to check if the status of "DELTA S SEN" is normal.

Condition	DELTA S SEN (DATA MONITOR)
When brake pedal is depressed.	1.05–1.80 mm
When brake pedal is released.	0.00 mm (+0.6/-0.4)

Is the inspection result normal?

YES >> Replace the ABS actuator and electric unit (control unit). Refer to [BRC-255. "Removal and Installation"](#).

NO >> Replace the delta stroke sensor.

### Component Inspection

INFOID:000000001537238

#### 1.CHECK DATA MONITOR

Use "DATA MONITOR" to check if the status of "DELTA S SEN" is normal.

Condition	DELTA S SEN (DATA MONITOR)
When brake pedal is depressed.	1.05–1.80 mm
When brake pedal is released.	0.00 mm (+0.6/-0.4)

Is the inspection result normal?

YES >> INSPECTION END

NO >> Go to diagnosis procedure. Refer to [BRC-217. "Diagnosis Procedure"](#).

### Special Repair Requirement

INFOID:000000001675451

#### 1.AJUSTMENT OF STEERING ANGLE SENSOR NEUTRAL POSITION

Always perform neutral position adjustment for the steering angle sensor when replacing the ABS actuator and electric unit (control unit). Refer to [BRC-150. "ADJUSTMENT OF STEERING ANGLE SENSOR NEUTRAL POSITION : Description"](#).

>> GO TO 2

#### 2.CALIBRATION OF DECEL G SENSOR

Always perform calibration of decel G sensor when replacing the ABS actuator and electric unit (control unit). Refer to [BRC-151. "CALIBRATION OF DECEL G SENSOR : Description"](#).

>> END

## U1000 CAN COMM CIRCUIT

### Description

INFOID:000000001537240

CAN (Controller Area Network) is a serial communication line for real time application. It is an on-vehicle multiplex communication line with high data communication speed and excellent error detection ability. Many electronic control units are equipped onto a vehicle, and each control unit shares information and links with other control units during operation (not independent). In CAN communication, control units are connected with 2 communication lines (CAN H line, CAN L line) allowing a high rate of information transmission with less wiring. Each control unit transmits/receives data but selectively reads required data only.

### DTC Logic

INFOID:000000001537241

### DTC DETECTION LOGIC

DTC	Display item	Malfunction detected condition	Possible cause
U1000	CAN COMM CIRCUIT	When ABS actuator and electric unit (control unit) is not transmitting or receiving CAN communication signal for 2 seconds or more.	<ul style="list-style-type: none"> <li>• CAN communication line</li> <li>• ABS actuator and electric unit (control unit)</li> </ul>

A  
B  
C  
D  
E  
**BRC**

### Diagnosis Procedure

INFOID:000000001537242

#### INSPECTION PROCEDURE

#### 1. CHECK CONNECTOR

1. Turn ignition switch OFF, disconnect the ABS actuator and electric unit (control unit) connector, and check the terminals for deformation, disconnection, looseness, and so on. If there is a malfunction, repair or replace the terminal.
2. Reconnect connector and perform self-diagnosis.

Is "CAN COMM CIRCUIT" displayed in self-diagnosis display items?

- YES >> Print out the self-diagnostic results, and refer to [LAN-14, "Trouble Diagnosis Flow Chart"](#).  
 NO >> Connector terminal is loose, damaged, open, or shorted.

### Special Repair Requirement

INFOID:000000001675452

#### 1. ADJUSTMENT OF STEERING ANGLE SENSOR NEUTRAL POSITION

Always perform neutral position adjustment for the steering angle sensor when replacing the ABS actuator and electric unit (control unit). Refer to [BRC-150, "ADJUSTMENT OF STEERING ANGLE SENSOR NEUTRAL POSITION : Description"](#).

>> GO TO 2

#### 2. CALIBRATION OF DECEL G SENSOR

Always perform calibration of decel G sensor when replacing the ABS actuator and electric unit (control unit). Refer to [BRC-151, "CALIBRATION OF DECEL G SENSOR : Description"](#).

>> END

G  
H  
I  
J  
K  
L  
M  
N  
O  
P

# VDC OFF SWITCH

< COMPONENT DIAGNOSIS >

[VDC/TCS/ABS]

## VDC OFF SWITCH

### Description

INFOID:000000001537244

VDC OFF switch can deactivate (turn OFF) the VDC/TCS function by pressing the VDC OFF switch.

### Component Function Check

INFOID:000000001537245

#### 1. CHECK VDC OFF SWITCH OPERATION

Turn ON/OFF the VDC OFF switch and check that the VDC OFF indicator lamp in the combination meter turns ON/OFF correctly.

Condition	VDC OFF indicator lamp illumination status
VDC OFF switch: ON	ON
VDC OFF switch: OFF	OFF

Is the inspection result normal?

YES >> INSPECTION END

NO >> Go to diagnosis procedure. Refer to [BRC-220, "Diagnosis Procedure"](#).

### Diagnosis Procedure

INFOID:000000001537246

#### 1. CHECK VDC OFF SWITCH

1. Turn ignition switch OFF.
2. Disconnect VDC OFF switch connector.
3. Check continuity between VDC OFF switch terminals.

VDC OFF switch	Condition	Continuity
Terminal		
1 - 2	When VDC OFF switch is pressed.	Yes
	When VDC OFF switch is released.	No

Is the inspection result normal?

YES >> GO TO 2

NO >> Replace VDC OFF switch.

#### 2. CHECK VDC OFF SWITCH HARNESS

1. Disconnect ABS actuator and electric unit (control unit) connector.
2. Check continuity between ABS actuator and electric unit (control unit) connector E125 (A) and VDC OFF switch connector M148 (B).

ABS actuator and electric unit (control unit)		VDC OFF switch		Continuity
Connector	Terminal	Connector	Terminal	
A: E125	38	B: M148	1	Yes

3. Check continuity between ABS actuator and electric unit (control unit) connector E125 (A) and ground.

ABS actuator and electric unit (control unit)		—	Continuity
Connector	Terminal		
A: E125	38	Ground	No

Is the inspection result normal?

YES >> GO TO 3

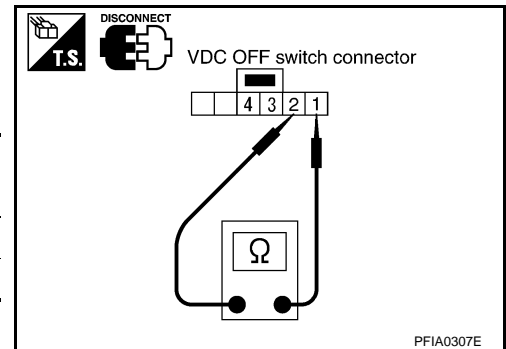

PFIA0307E

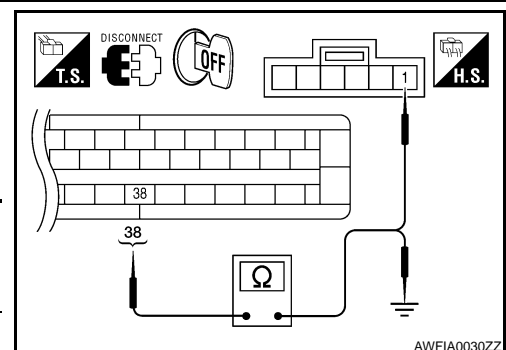

AWFIA0030ZZ

# VDC OFF SWITCH

[VDC/TCS/ABS]

## < COMPONENT DIAGNOSIS >

NO >> Repair or replace harness.

### 3.CHECK VDC OFF SWITCH GROUND

Check continuity between VDC OFF switch connector M148 and ground.

VDC OFF switch		—	Continuity
Connector	Terminal		
M148	2	Ground	Yes

Is the inspection result normal?

YES >> GO TO 4

NO >> Repair or replace harness.

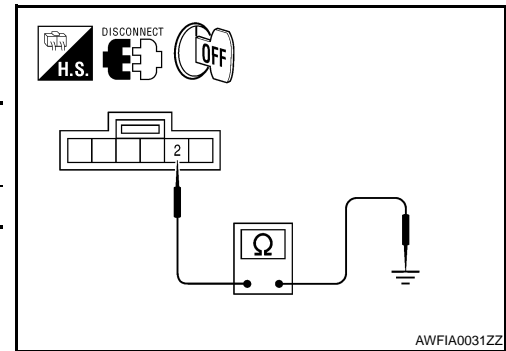

### 4.CHECK COMBINATION METER

Check if the indication and operation of combination meter are normal. Refer to [MWI-26. "Diagnosis Description"](#).

Is the inspection result normal?

YES >> Replace ABS actuator and electric unit (control unit). Refer to [BRC-255. "Removal and Installation"](#).

NO >> Replace combination meter. Refer to [MWI-72. "Removal and Installation"](#).

## Component Inspection

INFOID:000000001537247

### INSPECTION PROCEDURE

#### 1.CHECK VDC OFF SWITCH

1. Turn ignition switch OFF.
2. Disconnect VDC OFF switch connector.
3. Check continuity between VDC OFF switch terminals.

VDC OFF switch		Condition	Continuity
Terminal			
1 - 2		When VDC OFF switch is pressed.	Yes
		When VDC OFF switch is released.	No

Is the inspection result normal?

YES >> INSPECTION END

NO >> Replace VDC OFF switch.

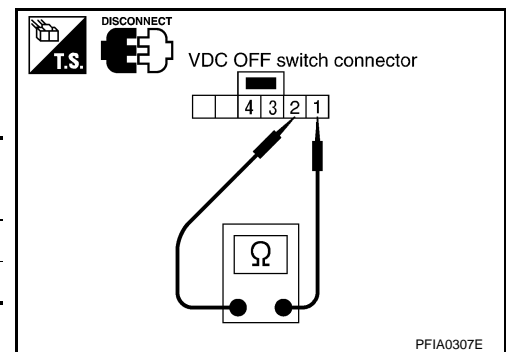

# ABS WARNING LAMP

< COMPONENT DIAGNOSIS >

[VDC/TCS/ABS]

## ABS WARNING LAMP

### Description

INFOID:000000001537248

×: ON –: OFF

Condition	ABS warning lamp
Ignition switch OFF	–
For 1 second after turning ON ignition switch	×
1 second later after turning ON ignition switch	–
ABS function is malfunctioning.	×
EBD function is malfunctioning.	×

### Component Function Check

INFOID:000000001537249

#### 1.CHECK ABS WARNING LAMP OPERATION

Check that the lamp illuminates for approximately 1 second after the ignition switch is turned ON.

Is the inspection result normal?

YES >> INSPECTION END

NO >> Go to diagnosis procedure. Refer to [BRC-222, "Diagnosis Procedure"](#).

### Diagnosis Procedure

INFOID:000000001537250

#### 1.CHECK SELF-DIAGNOSIS

Perform ABS actuator and electric unit (control unit) self-diagnosis. Refer to [BRC-165, "CONSULT-III Function \(ABS\)"](#).

Is the inspection result normal?

YES >> GO TO 2

NO >> Check items displayed by self-diagnosis.

#### 2.CHECK COMBINATION METER

Check if the indication and operation of combination meter are normal. Refer to [MWI-26, "Diagnosis Description"](#).

Is the inspection result normal?

YES >> Replace ABS actuator and electric unit (control unit). Refer to [BRC-255, "Removal and Installation"](#).

NO >> Replace combination meter. Refer to [MWI-72, "Removal and Installation"](#).

# BRAKE WARNING LAMP

< COMPONENT DIAGNOSIS >

[VDC/TCS/ABS]

## BRAKE WARNING LAMP

### Description

INFOID:000000001537251

×: ON –: OFF

Condition	Brake warning lamp (Note 1)
Ignition switch OFF	–
For 1 second after turning ON ignition switch	× (Note 2)
1 second later after turning ON ignition switch	× (Note 2)
EBD function is malfunctioning.	×

#### NOTE:

- 1: Brake warning lamp will turn on in case of parking brake operation (when switch is ON) or of brake fluid level switch operation (when brake fluid is insufficient).
- 2: After starting engine, brake warning lamp is turned off.

### Component Function Check

INFOID:000000001537252

BRC

#### 1. BRAKE WARNING LAMP OPERATION CHECK

Check that the lamp illuminates for approximately 1 second after the ignition switch is turned ON.

Is the inspection result normal?

YES >> INSPECTION END

NO >> Go to diagnosis procedure. Refer to [BRC-223, "Diagnosis Procedure"](#).

### Diagnosis Procedure

INFOID:000000001537253

#### 1. CHECK SELF-DIAGNOSIS

Perform ABS actuator and electric unit (control unit) self-diagnosis. Refer to [BRC-165, "CONSULT-III Function \(ABS\)"](#).

Is the inspection result normal?

YES >> GO TO 2

NO >> Check items displayed by self-diagnosis.

#### 2. CHECK COMBINATION METER

Check if the indication and operation of combination meter are normal. Refer to [MWI-26, "Diagnosis Description"](#).

Is the inspection result normal?

YES >> Replace ABS actuator and electric unit (control unit). Refer to [BRC-255, "Removal and Installation"](#).

NO >> Replace combination meter. Refer to [MWI-72, "Removal and Installation"](#).

# VDC OFF INDICATOR LAMP

< COMPONENT DIAGNOSIS >

[VDC/TCS/ABS]

## VDC OFF INDICATOR LAMP

### Description

INFOID:000000001537254

×: ON –: OFF

Condition	VDC OFF indicator lamp
Ignition switch OFF	–
For 1 second after turning ON ignition switch	×
1 second later after turning ON ignition switch	–
VDC OFF switch turned ON. (VDC function is OFF.)	×
VDC/TCS function is malfunctioning.	×
ABS function is malfunctioning.	×
EBD function is malfunctioning.	×

### Component Function Check

INFOID:000000001537255

#### 1.VDC OFF INDICATOR LAMP OPERATION CHECK 1

Check that the lamp illuminates for approximately 1 second after the ignition switch is turned ON.

Is the inspection result normal?

YES >> GO TO 2

NO >> Go to diagnosis procedure. Refer to [BRC-224, "Diagnosis Procedure"](#).

#### 2.VDC OFF INDICATOR LAMP OPERATION CHECK 2

Check that the VDC OFF indicator lamp in the combination meter turns ON/OFF correctly when operating the VDC OFF switch.

Is the inspection result normal?

YES >> INSPECTION END

NO >> Check VDC OFF switch. Refer to [BRC-220, "Diagnosis Procedure"](#).

### Diagnosis Procedure

INFOID:000000001537256

#### 1.CHECK VDC OFF SWITCH

Check that the VDC OFF indicator lamp in the combination meter turns ON/OFF correctly when operating the VDC OFF switch.

Is the inspection result normal?

YES >> GO TO 2

NO >> Check VDC OFF switch. Refer to [BRC-220, "Diagnosis Procedure"](#).

#### 2.CHECK SELF-DIAGNOSIS

Perform ABS actuator and electric unit (control unit) self-diagnosis. Refer to [BRC-165, "CONSULT-III Function \(ABS\)"](#).

Is the inspection result normal?

YES >> GO TO 3

NO >> Check items displayed by self-diagnosis.

#### 3.CHECK COMBINATION METER

Check if the indication and operation of combination meter are normal. Refer to [MWI-26, "Diagnosis Description"](#).

Is the inspection result normal?

YES >> Replace ABS actuator and electric unit (control unit). Refer to [BRC-255, "Removal and Installation"](#).

NO >> Replace combination meter. Refer to [MWI-72, "Removal and Installation"](#).



# SLIP INDICATOR LAMP

< COMPONENT DIAGNOSIS >

[VDC/TCS/ABS]

## SLIP INDICATOR LAMP

### Description

INFOID:000000001537257

×: ON –: OFF

Condition	SLIP indicator lamp
Ignition switch OFF	–
For 1 second after turning ON ignition switch	×
1 second later after turning ON ignition switch	–
VDC/TCS function is malfunctioning.	×
ABS function is malfunctioning.	×
EBD function is malfunctioning.	×

### Component Function Check

INFOID:000000001537258

#### 1.CHECK SLIP INDICATOR LAMP OPERATION

Check that the lamp illuminates for approximately 1 second after the ignition switch is turned ON.

Is the inspection result normal?

YES >> INSPECTION END

NO >> Go to diagnosis procedure. Refer to [BRC-225. "Diagnosis Procedure"](#).

#### Diagnosis Procedure

INFOID:000000001537259

#### 1.CHECK SELF-DIAGNOSIS

Perform ABS actuator and electric unit (control unit) self-diagnosis. Refer to [BRC-165. "CONSULT-III Function \(ABS\)"](#).

Is the inspection result normal?

YES >> GO TO 2

NO >> Check items displayed by self-diagnosis.

#### 2.CHECK COMBINATION METER

Check if the indication and operation of combination meter are normal. Refer to [MWI-26. "Diagnosis Description"](#).

Is the inspection result normal?

YES >> Replace ABS actuator and electric unit (control unit). Refer to [BRC-255. "Removal and Installation"](#).

NO >> Replace combination meter. Refer to [MWI-72. "Removal and Installation"](#).

# ABS ACTUATOR AND ELECTRIC UNIT (CONTROL UNIT)

< ECU DIAGNOSIS >

[VDC/TCS/ABS]

## ECU DIAGNOSIS

### ABS ACTUATOR AND ELECTRIC UNIT (CONTROL UNIT)

Reference Value

INFOID:000000001537260

VALUES ON THE DIAGNOSIS TOOL

#### CAUTION:

The display shows the control unit calculation data, so a normal value might be displayed even in the event the output circuit (harness) is open or short-circuited.

CONSULT-III MONITOR ITEM

Monitor item	Display content	Data monitor	
		Condition	Reference value in normal operation
FR LH SENSOR	Wheel speed	0 [km/h (MPH)]	Vehicle stopped
		Nearly matches the speed meter display (± 10% or less)	Vehicle running (Note 1)
FR RH SENSOR	Wheel speed	0 [km/h (MPH)]	Vehicle stopped
		Nearly matches the speed meter display (± 10% or less)	Vehicle running (Note 1)
RR LH SENSOR	Wheel speed	0 [km/h (MPH)]	Vehicle stopped
		Nearly matches the speed meter display (± 10% or less)	Vehicle running (Note 1)
RR RH SENSOR	Wheel speed	0 [km/h (MPH)]	Vehicle stopped
		Nearly matches the speed meter display (± 10% or less)	Vehicle running (Note 1)
STOP LAMP SW	Stop lamp switch signal status	When brake pedal is depressed	ON
		When brake pedal is released	OFF
BATTERY VOLT	Battery voltage supplied to the ABS actuator and electric unit (control unit)	Ignition switch ON	10 – 16 V
GEAR	Gear position determined by TCM	1st gear	1
		2nd gear	2
		3rd gear	3
		4th gear	4
		5th gear	5
SLCT LVR POSI	A/T selector lever position	P position	P
		R position	R
		N position	N
		D position	D
OFF SW	VDC OFF switch ON/OFF	VDC OFF switch ON (When VDC OFF indicator lamp is ON)	ON
		VDC OFF switch OFF (When VDC OFF indicator lamp is OFF)	OFF
YAW RATE SEN	Yaw rate detected by yaw rate/side/decel G sensor	When vehicle is stopped	Approx. 0 d/s
		When vehicle turning	-75 to 75 d/s
ACCEL POS SIG	Throttle actuator opening/closing is displayed (linked with accelerator pedal)	Accelerator pedal not depressed (ignition switch is ON)	0 %
		Accelerator pedal depressed (ignition switch is ON)	0 - 100 %

# ABS ACTUATOR AND ELECTRIC UNIT (CONTROL UNIT)

< ECU DIAGNOSIS >

[VDC/TCS/ABS]

Monitor item	Display content	Data monitor		
		Condition	Reference value in normal operation	
SIDE G-SENSOR	Transverse G detected by side G sensor	Vehicle stopped	Approx. 0 m/s <sup>2</sup>	A
		Vehicle turning right	Negative value (m/s <sup>2</sup> )	B
		Vehicle turning left	Positive value (m/s <sup>2</sup> )	C
STR ANGLE SIG	Steering angle detected by steering angle sensor	Straight-ahead	Approx. 0°	
		Steering wheel turned	-720 to 720°	D
PRESS SENSOR	Brake fluid pressure detected by front pressure sensor	With ignition switch turned ON and brake pedal released	Approx. 0 bar	E
		With ignition switch turned ON and brake pedal depressed	-40 to 300 bar	
ENGINE SPEED	With engine running	With engine stopped	0 rpm	BRC
		Engine running	Almost in accordance with tachometer display	
FLUID LEV SW	Brake fluid level switch signal status	When brake fluid level switch ON	ON	G
		When brake fluid level switch OFF	OFF	
FR RH IN SOL	Operation status of each solenoid valve	Actuator (solenoid valve) is active ("ACTIVE TEST" with CONSULT-III) or actuator relay is inactive (in fail-safe mode)	ON	H
		When the actuator (solenoid valve) is not active and actuator relay is active (ignition switch ON)	OFF	I
FR RH OUT SOL	Operation status of each solenoid valve	Actuator (solenoid valve) is active ("ACTIVE TEST" with CONSULT-III) or actuator relay is inactive (in fail-safe mode)	ON	J
		When the actuator (solenoid valve) is not active and actuator relay is active (ignition switch ON)	OFF	K
FR LH IN SOL	Operation status of each solenoid valve	Actuator (solenoid valve) is active ("ACTIVE TEST" with CONSULT-III) or actuator relay is inactive (in fail-safe mode)	ON	L
		When the actuator (solenoid valve) is not active and actuator relay is active (ignition switch ON)	OFF	M
FR LH OUT SOL	Operation status of each solenoid valve	Actuator (solenoid valve) is active ("ACTIVE TEST" with CONSULT-III) or actuator relay is inactive (in fail-safe mode)	ON	N
		When the actuator (solenoid valve) is not active and actuator relay is active (ignition switch ON)	OFF	O
RR RH IN SOL	Operation status of each solenoid valve	Actuator (solenoid valve) is active ("ACTIVE TEST" with CONSULT-III) or actuator relay is inactive (in fail-safe mode)	ON	P
		When the actuator (solenoid valve) is not active and actuator relay is active (ignition switch ON)	OFF	

# ABS ACTUATOR AND ELECTRIC UNIT (CONTROL UNIT)

< ECU DIAGNOSIS >

[VDC/TCS/ABS]

Monitor item	Display content	Data monitor	
		Condition	Reference value in normal operation
RR RH OUT SOL	Operation status of each solenoid valve	Actuator (solenoid valve) is active ("ACTIVE TEST" with CONSULT-III) or actuator relay is inactive (in fail-safe mode)	ON
		When the actuator (solenoid valve) is not active and actuator relay is active (ignition switch ON)	OFF
RR LH IN SOL	Operation status of each solenoid valve	Actuator (solenoid valve) is active ("ACTIVE TEST" with CONSULT-III) or actuator relay is inactive (in fail-safe mode)	ON
		When the actuator (solenoid valve) is not active and actuator relay is active (ignition switch ON)	OFF
RR LH OUT SOL	Operation status of each solenoid valve	Actuator (solenoid valve) is active ("ACTIVE TEST" with CONSULT-III) or actuator relay is inactive (in fail-safe mode)	ON
		When the actuator (solenoid valve) is not active and actuator relay is active (ignition switch ON)	OFF
MOTOR RELAY	Motor and motor relay operation	When the motor relay and motor are operating	ON
		When the motor relay and motor are not operating	OFF
ACTUATOR RLY	Actuator relay operation	When the actuator relay is operating	ON
		When the actuator relay is not operating	OFF
ABS WARN LAMP	ABS warning lamp (Note 3)	When ABS warning lamp is ON	ON
		When ABS warning lamp is OFF	OFF
OFF LAMP	VDC OFF indicator lamp (Note 3)	When VDC OFF indicator lamp is ON	ON
		When VDC OFF indicator lamp is OFF	OFF
SLIP LAMP	SLIP indicator lamp (Note 3)	When SLIP indicator lamp is ON	ON
		When SLIP indicator lamp is OFF	OFF
4WD FAIL REQ (Note 2)	Transfer control unit fail-safe signal	When transfer control unit is in fail-safe mode	ON
		When transfer control unit is normal	OFF
BST OPER SIG	Active booster operation	Active booster is active	ON
		Active booster is inactive	OFF
EBD SIGNAL	EBD operation	EBD is active	ON
		EBD is inactive	OFF
ABS SIGNAL	ABS operation	ABS is active	ON
		ABS is inactive	OFF
TCS SIGNAL	TCS operation	TCS is active	ON
		TCS is inactive	OFF
VDC SIGNAL	VDC operation	VDC is active	ON
		VDC is inactive	OFF
EBD FAIL SIG	EBD fail-safe signal	In EBD fail-safe	ON
		EBD is normal	OFF
ABS FAIL SIG	ABS fail-safe signal	In ABS fail-safe	ON
		ABS is normal	OFF

# ABS ACTUATOR AND ELECTRIC UNIT (CONTROL UNIT)

< ECU DIAGNOSIS >

[VDC/TCS/ABS]

Monitor item	Display content	Data monitor	
		Condition	Reference value in normal operation
TCS FAIL SIG	TCS fail-safe signal	In TCS fail-safe	ON
		TCS is normal	OFF
VDC FAIL SIG	VDC fail-safe signal	In VDC fail-safe	ON
		VDC is normal	OFF
CRANKING SIG	Crank operation	Crank is active	ON
		Crank is inactive	OFF
CV1	VDC switch-over valve	When actuator (switch-over valve) is active ("ACTIVE TEST" with CONSULT-III) or actuator relay is inactive (when in fail-safe mode)	ON
		When actuator (switch-over valve) is not active and actuator relay is active (ignition switch ON)	OFF
CV2	VDC switch-over valve	When actuator (switch-over valve) is active ("ACTIVE TEST" with CONSULT-III) or actuator relay is inactive (when in fail-safe mode)	ON
		When actuator (switch-over valve) is not active and actuator relay is active (ignition switch ON)	OFF
SV1	VDC switch-over valve	When actuator (switch-over valve) is active ("ACTIVE TEST" with CONSULT-III) or actuator relay is inactive (when in fail-safe mode)	ON
		When actuator (switch-over valve) is not active and actuator relay is active (ignition switch ON)	OFF
SV2	VDC switch-over valve	When actuator (switch-over valve) is active ("ACTIVE TEST" with CONSULT-III) or actuator relay is inactive (when in fail-safe mode)	ON
		When actuator (switch-over valve) is not active and actuator relay is active (ignition switch ON)	OFF
DECEL G-SEN	Longitudinal acceleration detected by Decel G-Sensor	Vehicle stopped	Approx. 0 G
		Vehicle running	-1.7 to 1.7 G
EBD WARN LAMP	EBD warning lamp (Note 3)	When EBD warning lamp is ON	ON
		When EBD warning lamp is OFF	OFF
N POSI SIG	PNP switch signal ON/OFF condition	A/T shift position = N position	ON
		A/T shift position = other than N position	OFF
P POSI SIG	PNP switch signal ON/OFF condition	A/T shift position = P position	ON
		A/T shift position = other than P position	OFF
R POSI SIG	PNP switch signal ON/OFF condition	A/T shift position = R position	ON
		A/T shift position = other than R position	OFF
2WD/4WD	Drive axle	2WD model	2WD
		4WD model	4WD
PRESS SEN2	Brake fluid pressure detected by rear pressure sensor	With ignition switch turned ON and brake pedal released	Approx. 0 bar
		With ignition switch turned ON and brake pedal depressed	-40 to 300 bar

A  
B  
C  
D  
E  
BRC  
G  
H  
I  
J  
K  
L  
M  
N  
O  
P

# ABS ACTUATOR AND ELECTRIC UNIT (CONTROL UNIT)

< ECU DIAGNOSIS >

[VDC/TCS/ABS]

Monitor item	Display content	Data monitor	
		Condition	Reference value in normal operation
DELTA S SEN	Value detected by delta stroke sensor	When brake pedal is depressed	1.05 - 1.80 mm
		When brake pedal is released	0.00 mm (+0.6/-0.4)
RELEASE SWITCH NO	Active booster signal status	When brake pedal is depressed	ON
		When brake pedal is released	OFF
RELEASE SWITCH NC	Active booster signal status	When brake pedal is depressed	OFF
		When brake pedal is released	ON
STP OFF RLY	Stop lamp relay signal	When stop lamp relay is ON	ON
		When stop lamp relay is OFF	OFF
PRES CTRL ACC	This item is not used for this model.	—	—
PRES FAIL ACC	This item is not used for this model.	—	—

**NOTE:**

- 1: Confirm tire pressure is normal.
- 2: Only 4WD models.
- 3: On and off timing for warning lamp and indicator lamp.
- ABS warning lamp: Refer to [BRC-222, "Description"](#).
- Brake warning lamp: Refer to [BRC-223, "Description"](#).
- VDC OFF indicator lamp: Refer to [BRC-224, "Description"](#).
- SLIP indicator lamp: Refer to [BRC-225, "Description"](#).

**TERMINAL LAYOUT**

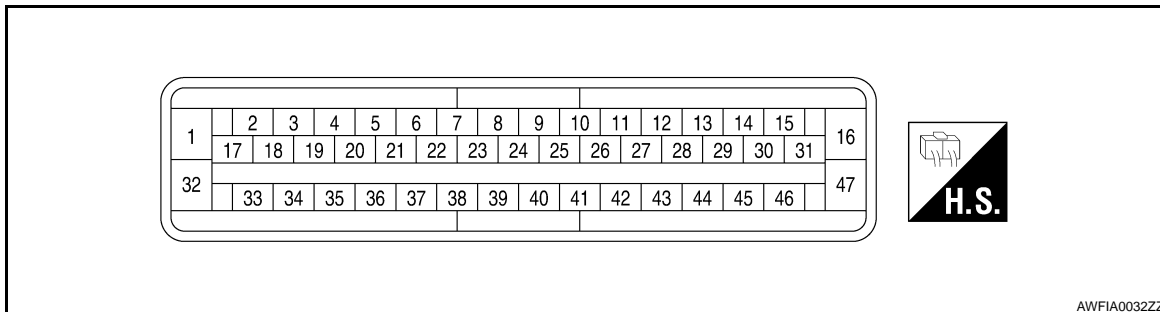

# ABS ACTUATOR AND ELECTRIC UNIT (CONTROL UNIT)

< ECU DIAGNOSIS >

[VDC/TCS/ABS]

## Wiring Diagram

INFOID:000000001537261

--- : DATA LINE

### BRAKE CONTROL SYSTEM - VDC

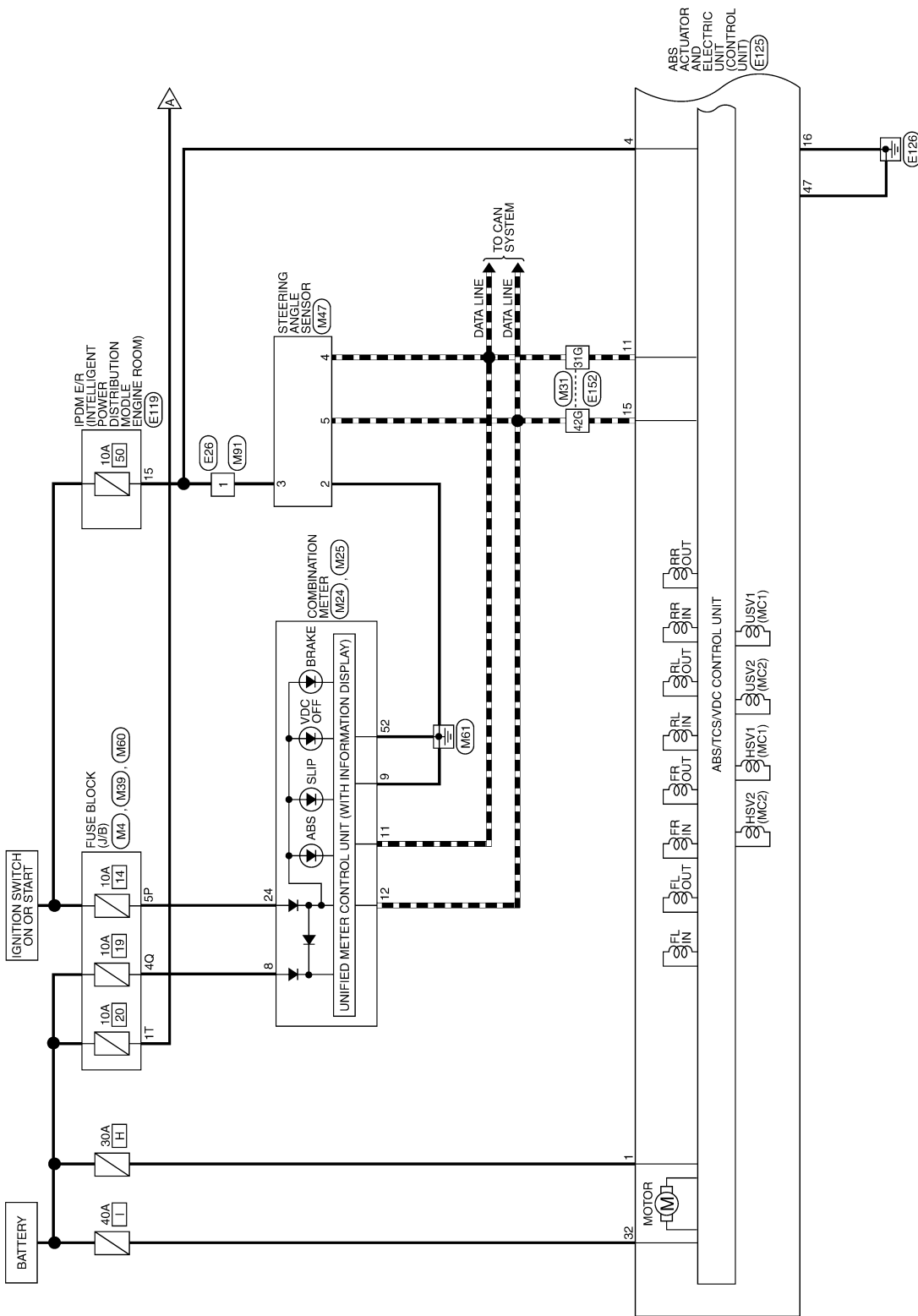

A  
B  
C  
D  
E  
F  
G  
H  
I  
J  
K  
L  
M  
N  
O  
P

BRC

AWFWA0005GI





# ABS ACTUATOR AND ELECTRIC UNIT (CONTROL UNIT)

< ECU DIAGNOSIS >

[VDC/TCS/ABS]

## BRAKE CONTROL SYSTEM - VDC CONNECTORS

Connector No.	M4
Connector Name	FUSE BLOCK (J/B)
Connector Color	WHITE

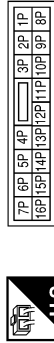

Terminal No.	Color of Wire	Signal Name
5P	O/L	-

Connector No.	M22
Connector Name	DATA LINK CONNECTOR
Connector Color	WHITE

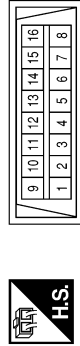

Terminal No.	Color of Wire	Signal Name
7	G/W	K-LINE

Connector No.	M24
Connector Name	COMBINATION METER
Connector Color	WHITE

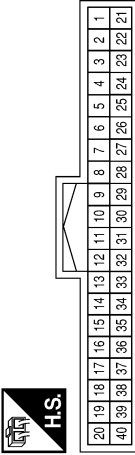

Terminal No.	Color of Wire	Signal Name
8	Y/R	-
9	B	-
11	L	CAN+H
12	P	CAN-L
24	O/L	-

Connector No.	M25
Connector Name	COMBINATION METER
Connector Color	WHITE

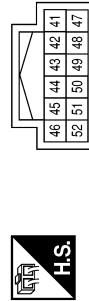

Terminal No.	Color of Wire	Signal Name
52	B	-

Connector No.	M31
Connector Name	WIRE TO WIRE
Connector Color	WHITE

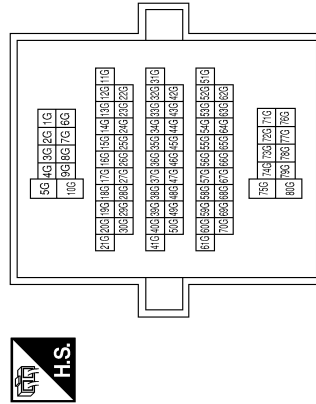

Terminal No.	Color of Wire	Signal Name
11G	G/W	-
31G	L	-
42G	P	-
46G	R/Y	-

A  
B  
C  
D  
E  
BRC  
G  
H  
I  
J  
K  
L  
M  
N  
O  
P

# ABS ACTUATOR AND ELECTRIC UNIT (CONTROL UNIT)

< ECU DIAGNOSIS >

[VDC/TCS/ABS]

Connector No.	M60
Connector Name	FUSE BLOCK (J/B)
Connector Color	WHITE

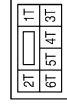

Terminal No.	Color of Wire	Signal Name
1T	R/Y	-

Connector No.	M47
Connector Name	STEERING ANGLE SENSOR
Connector Color	WHITE

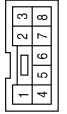

Terminal No.	Color of Wire	Signal Name
2	B	GND
3	G/W	POWER
4	L	CAN-H
5	P	CAN-L

Connector No.	M39
Connector Name	FUSE BLOCK (J/B)
Connector Color	WHITE

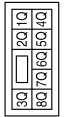

Terminal No.	Color of Wire	Signal Name
4Q	Y/R	-

Connector No.	M148
Connector Name	VDC OFF SWITCH
Connector Color	GRAY

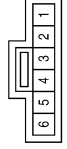

Terminal No.	Color of Wire	Signal Name
1	R/W	-
2	B	-

Connector No.	M108
Connector Name	YAW RATE/SIDE/DECEL G SENSOR
Connector Color	BLACK

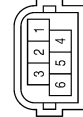

Terminal No.	Color of Wire	Signal Name
1	G/R	CAN-L
2	G/W	CAN-H
3	Y/R	CLU_P
5	P	CLU_GND

Connector No.	M91
Connector Name	WIRE TO WIRE
Connector Color	WHITE

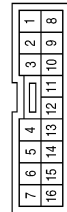

Terminal No.	Color of Wire	Signal Name
1	G/W	-
2	R/W	-
3	Y/R	-
4	G/R	-
5	G/W	-
6	P	-

AWFIA0059GB

# ABS ACTUATOR AND ELECTRIC UNIT (CONTROL UNIT)

< ECU DIAGNOSIS >

[VDC/TCS/ABS]

Connector No.	E21
Connector Name	BRAKE FLUID LEVEL SWITCH
Connector Color	GRAY



Terminal No.	Color of Wire	Signal Name
1	P/B	-
2	B	-

Connector No.	E18
Connector Name	FRONT WHEEL SENSOR LH
Connector Color	GRAY



Terminal No.	Color of Wire	Signal Name
1	G/O	-
2	BR/W	-

Connector No.	E12
Connector Name	STOP LAMP RELAY
Connector Color	BLACK



Terminal No.	Color of Wire	Signal Name
1	R/Y	-
2	L/W	-
3	R/G	-
4	R/B	-
5	-	-

Connector No.	E32
Connector Name	REAR PRESSURE SENSOR
Connector Color	GRAY

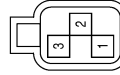

Terminal No.	Color of Wire	Signal Name
1	R/G	GND
2	W/O	SIG
3	W/L	POWER

Connector No.	E31
Connector Name	FRONT PRESSURE SENSOR
Connector Color	GRAY

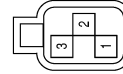

Terminal No.	Color of Wire	Signal Name
1	SB	GND
2	R/L	SIG
3	LG	POWER

Connector No.	E26
Connector Name	WIRE TO WIRE
Connector Color	WHITE

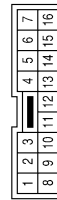

Terminal No.	Color of Wire	Signal Name
1	LG/B	-
2	R/W	-
3	Y/R	-
4	G/R	-
5	G/W	-
6	P	-

AWFIA0060GB

A  
B  
C  
D  
E  
F  
G  
H  
I  
J  
K  
L  
M  
N  
O  
P

BRC

# ABS ACTUATOR AND ELECTRIC UNIT (CONTROL UNIT)

< ECU DIAGNOSIS >

[VDC/TCS/ABS]

Connector No.	E38
Connector Name	STOP LAMP SWITCH (FLOOR SHIFT)
Connector Color	BLACK



Terminal No.	Color of Wire	Signal Name
1	R/Y	-
2	R/G	-

Connector No.	E38
Connector Name	STOP LAMP SWITCH (COLUMN SHIFT)
Connector Color	WHITE



Terminal No.	Color of Wire	Signal Name
1	R/Y	-
2	R/G	-

Connector No.	E41
Connector Name	WIRE TO WIRE
Connector Color	GRAY

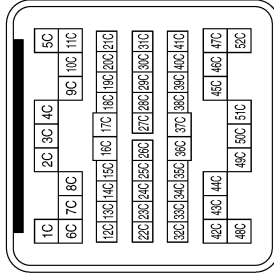

Terminal No.	Color of Wire	Signal Name
12C	L	-
13C	P	-
30C	G/Y	-
31C	V	-

Connector No.	E49
Connector Name	ACTIVE BOOSTER
Connector Color	BLACK



Terminal No.	Color of Wire	Signal Name
1	L/B	-
2	LG/R	-
3	W/R	-
4	W/G	-
5	Y/B	-

Connector No.	E114
Connector Name	DELTA STROKE SENSOR
Connector Color	BLACK



Terminal No.	Color of Wire	Signal Name
1	W/V	DELS_PWR
3	G/B	DELS_GND
5	R/Y	DELS_SIG

Connector No.	E117
Connector Name	FRONT WHEEL SENSOR RH
Connector Color	GRAY



Terminal No.	Color of Wire	Signal Name
1	B/R	-
2	BR	-

AWFIA0061GB

# ABS ACTUATOR AND ELECTRIC UNIT (CONTROL UNIT)

< ECU DIAGNOSIS >

[VDC/TCS/ABS]

Connector No.	E125
Connector Name	ABS ACTUATOR AND ELECTRIC UNIT (CONTROL UNIT)
Connector Color	BLACK



1	2	3	4	5	6	7	8	9	10	11	12	13	14	15	16
17	18	19	20	21	22	23	24	25	26	27	28	29	30	31	32
33	34	35	36	37	38	39	40	41	42	43	44	45	46	47	

Connector No.	E119
Connector Name	IPDM E/R (INTELLIGENT POWER DISTRIBUTION MODULE ENGINE ROOM)
Connector Color	WHITE



9	8	7	6	5	4	3		
18	17	16	15	14	13	12	11	10

Terminal No.	Color of Wire	Signal Name
15	LG/B	ABS IGN SUPPLY

Terminal No.	Color of Wire	Signal Name
1	Y	MOTOR_SUPPLY
2	V	DIAG_K
4	LG/B	IGN
6	Y/R	CLUSTER_SUPPLY
8	P/B	FLUID_LEVEL_SW
11	L	CAN-H
15	P	CAN-L
16	B	VALVE_ECU_GND
17	W/R	BST_SUPPLY
18	LG	PS1 - SUPPLY

Terminal No.	Color of Wire	Signal Name
19	SB	PS1 - GND
20	R/L	PS1_SIGNAL
21	R/G	PS2_GND
22	W/L	PS2_SUPPLY
23	W/O	PS2_SIGNAL
24	P	CLUSTER_GND
25	G/R	CAN2_L
26	W/V	DEL_S_SUPPLY
27	L/B	BST_NO
28	Y/B	BST_SIG
29	G/W	CAN2_H
30	LG/R	BST_NC
31	W/G	BST_GND
32	B/Y	VALVE_ECU_SUPPLY
33	BR	WSS_FR_SIG
34	B/R	WSS_FR_PWR
35	L/W	BRL_OUT
36	L	WSS_RL_PWR
37	P	WSS_RL_SIG
38	R/W	VDC_OFF_SW
39	G/B	DEL_S_GND
40	R/Y	DEL_S_SIGNAL
41	R/B	BLS
42	V	WSS_RR_SIG
43	G/Y	WSS_RR_PWR
45	G/O	WSS_FL_PWR
46	BR/W	WSS_FL_SIG
47	B	MOTOR_GND

A  
B  
C  
D  
E  
F  
G  
H  
I  
J  
K  
L  
M  
N  
O  
P

BRC

# ABS ACTUATOR AND ELECTRIC UNIT (CONTROL UNIT)

< ECU DIAGNOSIS >

[VDC/TCS/ABS]

Connector No.	C1
Connector Name	WIRE TO WIRE
Connector Color	GRAY

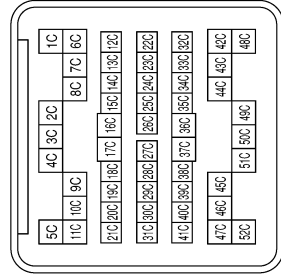

Terminal No.	Color of Wire	Signal Name
12C	L	-
13C	P	-
30C	G/Y	-
31C	V	-

Terminal No.	Color of Wire	Signal Name
11G	G/W	-
31G	L	-
42G	P	-
46G	R/Y	-

Connector No.	E152
Connector Name	WIRE TO WIRE
Connector Color	WHITE

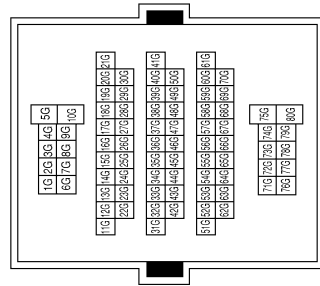

Connector No.	C11
Connector Name	REAR WHEEL SENSOR LH
Connector Color	BROWN



Terminal No.	Color of Wire	Signal Name
1	L	-
2	P	-

Connector No.	C10
Connector Name	REAR WHEEL SENSOR RH
Connector Color	GRAY



Terminal No.	Color of Wire	Signal Name
1	G/Y	-
2	V	-

Fail-Safe

**CAUTION:**

If the Fail-Safe function is activated, perform Self Diagnosis for ABS/TCS/VDC system.

ABS/EBD SYSTEM

AWFIA0063GB

INFOID:000000001537262

# ABS ACTUATOR AND ELECTRIC UNIT (CONTROL UNIT)

< ECU DIAGNOSIS >

[VDC/TCS/ABS]

In case of an electrical malfunction with the ABS, the ABS warning lamp, VDC OFF indicator lamp and SLIP indicator lamp will turn on. In case of an electrical malfunction with the EBD system, the BRAKE warning lamp, ABS warning lamp, VDC OFF indicator lamp and SLIP indicator lamp will turn on. The system will revert to one of the following conditions of the Fail-Safe function.

1. For ABS malfunction, only the EBD is operative and the condition of the vehicle is the same condition of vehicles without ABS/TCS/VDC system.
2. For EBD malfunction, the EBD and ABS become inoperative, and the condition of the vehicle is the same as the condition of vehicles without ABS/TCS/VDC or EBD system.

## VDC/TCS SYSTEM

In case of TCS/VDC system malfunction, the VDC OFF indicator lamp and SLIP indicator lamp are turned on and the condition of the vehicle is the same as the condition of vehicles without TCS/VDC system. In case of an electrical malfunction with the TCS/VDC system, the ABS control continues to operate normally without TCS/VDC control.

## DTC No. Index

INFOID:000000001537263

DTC	Items (CONSULT screen terms)	Reference
C1101	RR RH SENSOR-1	<a href="#">BRC-170, "Description"</a>
C1102	RR LH SENSOR-1	
C1103	FR RH SENSOR-1	
C1104	FR LH SENSOR-1	
C1105	RR RH SENSOR-2	<a href="#">BRC-173, "Description"</a>
C1106	RR LH SENSOR-2	
C1107	FR RH SENSOR-2	
C1108	FR LH SENSOR-2	
C1109	BATTERY VOLTAGE [ABNORMAL]	<a href="#">BRC-176, "Description"</a>
C1110	CONTROLLER FAILURE	<a href="#">BRC-178, "DTC Logic"</a>
C1111	PUMP MOTOR	<a href="#">BRC-179, "Description"</a>
C1113	G-SENSOR	<a href="#">BRC-181, "Description"</a>
C1115	ABS SENSOR [ABNORMAL SIGNAL]	<a href="#">BRC-184, "Description"</a>
C1116	STOP LAMP SW	<a href="#">BRC-187, "Description"</a>
C1120	FR LH IN ABS SOL	<a href="#">BRC-189, "Description"</a>
C1121	FR LH OUT ABS SOL	<a href="#">BRC-192, "Description"</a>
C1122	FR RH IN ABS SOL	<a href="#">BRC-189, "Description"</a>
C1123	FR RH OUT ABS SOL	<a href="#">BRC-192, "Description"</a>
C1124	RR LH IN ABS SOL	<a href="#">BRC-189, "Description"</a>
C1125	RR LH OUT ABS SOL	<a href="#">BRC-192, "Description"</a>
C1126	RR RH IN ABS SOL	<a href="#">BRC-189, "Description"</a>
C1127	RR RH OUT ABS SOL	<a href="#">BRC-192, "Description"</a>
C1130	ENGINE SIGNAL 1	<a href="#">BRC-195, "Description"</a>
C1131	ENGINE SIGNAL 2	
C1132	ENGINE SIGNAL 3	
C1133	ENGINE SIGNAL 4	
C1136	ENGINE SIGNAL 6	
C1140	ACTUATOR RLY	
C1142	PRESS SEN CIRCUIT	<a href="#">BRC-199, "Description"</a>
C1143	ST ANG SEN CIRCUIT	<a href="#">BRC-202, "Description"</a>
C1144	ST ANG SEN SIGNAL	

# ABS ACTUATOR AND ELECTRIC UNIT (CONTROL UNIT)

< ECU DIAGNOSIS >

[VDC/TCS/ABS]

DTC	Items (CONSULT screen terms)	Reference
C1145	YAW RATE SENSOR	<a href="#">BRC-181. "Description"</a>
C1146	SIDE G-SEN CIRCUIT	
C1155	BR FLUID LEVEL LOW	<a href="#">BRC-205. "Description"</a>
C1156	ST ANG SEN COM CIR	<a href="#">BRC-208. "Description"</a>
C1160	DECEL G SEN SET	<a href="#">BRC-209. "Description"</a>
C1163	ST ANGL SEN SAFE	<a href="#">BRC-210. "Description"</a>
C1164	CV1	<a href="#">BRC-211. "Description"</a>
C1165	CV2	
C1166	SV1	
C1167	SV2	
C1170	VARIANT CODING	<a href="#">BRC-178. "DTC Logic"</a>
C1178	ABS ACTIVE BOOSTER SV NG	<a href="#">BRC-214. "Description"</a>
C1179	ABS DELTA S SEN NG	<a href="#">BRC-217. "Description"</a>
C1181	ABS ACTIVE BOOSTER RESPONSE NG	<a href="#">BRC-214. "Description"</a>
C1184	ABS BRAKE RELEASE SW NG	
C1189	ABS BRAKE BOOSTER DEFECT	
U1000	CAN COMM CIRCUIT	<a href="#">BRC-219. "Description"</a>



# SYMPTOM DIAGNOSIS

## VDC/TCS/ABS

### Symptom Table

INFOID:000000001537264

If ABS warning lamp, VDC OFF indicator lamp and SLIP indicator lamp turn ON, perform self-diagnosis.

Symptom	Check item	Reference
Excessive ABS function operation frequency	Brake force distribution	<a href="#">BRC-242, "Diagnosis Procedure"</a>
	Looseness of front and rear axle	
	Wheel sensor and rotor system	
Unexpected pedal reaction	Brake pedal stroke	<a href="#">BRC-243, "Diagnosis Procedure"</a>
	Make sure the braking force is sufficient when the ABS is not operating.	
The braking distance is long	Check stopping distance when the ABS is not operating.	<a href="#">BRC-244, "Diagnosis Procedure"</a>
ABS function does not operate (Note 1)	ABS actuator and electric unit (control unit)	<a href="#">BRC-245, "Diagnosis Procedure"</a>
Pedal vibration or ABS operation sound occurs (Note 2)	Brake pedal	<a href="#">BRC-246, "Diagnosis Procedure"</a>
	ABS actuator and electric unit (control unit)	
Vehicle jerks during VDC/TCS/ABS control	ABS actuator and electric unit (control unit)	<a href="#">BRC-247, "Diagnosis Procedure"</a>
	TCM	
	ECM	

#### NOTE:

- 1: The ABS does not operate when the speed is 10 km/h (6 MPH) or less.
- 2: Under the following conditions, ABS is activated and vibration is felt when brake pedal is lightly depressed. However, this is normal.
  - When shifting gears
  - When driving on slippery road
  - During cornering at high speed
  - When passing over bumps or grooves [at approximately 50 mm (1.97 in) or more]
  - When pulling away just after starting engine [at approximately 10 km/h (6 MPH) or higher]

# EXCESSIVE ABS FUNCTION OPERATION FREQUENCY

< SYMPTOM DIAGNOSIS >

[VDC/TCS/ABS]

## EXCESSIVE ABS FUNCTION OPERATION FREQUENCY

### Diagnosis Procedure

INFOID:000000001537265

#### 1.CHECK START

Check front and rear brake force distribution using a brake tester.

Is the inspection result normal?

YES >> GO TO 2

NO >> Check brake system.

#### 2.CHECK FRONT AND REAR AXLE

Make sure that there is no excessive play in the front and rear axles. Refer to front: [FAX-5. "On-Vehicle Inspection and Service"](#), Rear: [RAX-5. "On-Vehicle Inspection"](#).

Is the inspection result normal?

YES >> GO TO 3

NO >> Repair or replace malfunctioning components.

#### 3.CHECK WHEEL SENSOR AND SENSOR ROTOR

Check the following.

- Wheel sensor installation for damage.
- Sensor rotor installation for damage.
- Wheel sensor connector connection.
- Wheel sensor harness inspection.

Is the inspection result normal?

YES >> GO TO 4

NO >> • Replace wheel sensor or sensor rotor. Refer to [BRC-253. "Removal and Installation"](#).  
• Repair harness.

#### 4.CHECK ABS WARNING LAMP DISPLAY

Make sure that the ABS warning lamp is turned off after the ignition switch is turned ON or when driving.

Is the ABS warning lamp illuminated?

YES >> Perform self-diagnosis. Refer to [BRC-165. "CONSULT-III Function \(ABS\)"](#).

NO >> Normal

# UNEXPECTED PEDAL REACTION

< SYMPTOM DIAGNOSIS >

[VDC/TCS/ABS]

## UNEXPECTED PEDAL REACTION

### Diagnosis Procedure

INFOID:000000001537266

#### 1.CHECK BRAKE PEDAL STROKE

Check brake pedal stroke. Refer to [BR-14, "Inspection and Adjustment"](#).

Is the stroke too large?

- YES >> • Bleed air from brake tube and hose. Refer to [BR-16, "Bleeding Brake System"](#).  
• Check brake pedal, brake booster, and master cylinder for mount play, looseness, brake system fluid leakage, etc. Refer to [BR-14, "Inspection and Adjustment"](#) (brake pedal), [BR-26, "With ABLs or VDC"](#) (master cylinder), [BR-28, "On-Vehicle Service"](#) (brake booster).

NO >> GO TO 2

#### 2.CHECK FUNCTION

Disconnect ABS actuator and electric unit (control unit) connector to deactivate ABS. Check if braking force is normal in this condition. Connect connector after inspection.

Is the inspection result normal?

- YES >> Normal  
NO >> Check brake system.

A  
B  
C  
D  
E  
F  
G  
H  
I  
J  
K  
L  
M  
N  
O  
P

BRC

## THE BRAKING DISTANCE IS LONG

< SYMPTOM DIAGNOSIS >

[VDC/TCS/ABS]

---

### THE BRAKING DISTANCE IS LONG

#### Diagnosis Procedure

INFOID:000000001537267

**CAUTION:**

The stopping distance on slippery road surfaces might be longer with the ABS operating than when the ABS is not operating.

**1**.CHECK FUNCTION

---

Turn ignition switch OFF and disconnect ABS actuator and electric unit (control unit) connector to deactivate ABS. In this condition, check stopping distance. After inspection, connect connector.

Is the inspection result normal?

YES >> Normal

NO >> Check brake system.

# ABS FUNCTION DOES NOT OPERATE

< SYMPTOM DIAGNOSIS >

[VDC/TCS/ABS]

## ABS FUNCTION DOES NOT OPERATE

### Diagnosis Procedure

INFOID:000000001537268

**CAUTION:**

**ABS does not operate when speed is 10 km/h (6 MPH) or lower.**

**1**.CHECK ABS WARNING LAMP DISPLAY

Make sure that the ABS warning lamp turns OFF after ignition switch is turned ON or when driving.

Is the inspection result normal?

YES >> Normal

NO >> Perform self-diagnosis. Refer to [BRC-165, "CONSULT-III Function \(ABS\)"](#).

A  
B  
C  
D  
E  
G  
H  
I  
J  
K  
L  
M  
N  
O  
P

**BRC**

# PEDAL VIBRATION OR ABS OPERATION SOUND OCCURS

< SYMPTOM DIAGNOSIS >

[VDC/TCS/ABS]

## PEDAL VIBRATION OR ABS OPERATION SOUND OCCURS

### Diagnosis Procedure

INFOID:000000001537269

#### **CAUTION:**

Under the following conditions, ABS is activated and vibration is felt when brake pedal is lightly depressed. However, this is normal.

- When shifting gears
- When driving on slippery road
- During cornering at high speed
- When passing over bumps or grooves [at approximately 50 mm (1.97 in) or more]
- When pulling away just after starting engine [at approximately 10 km/h (6 MPH) or higher]

#### 1. SYMPTOM CHECK 1

Check that there are pedal vibrations when the engine is started.

Do vibrations occur?

- YES >> GO TO 2  
NO >> Inspect the brake pedal.

#### 2. SYMPTOM CHECK 2

Check that there are ABS operation noises when the engine is started.

Do the operation noises occur?

- YES >> GO TO 3  
NO >> Perform self -diagnosis. Refer to [BRC-165. "CONSULT-III Function \(ABS\)".](#)

#### 3. SYMPTOM CHECK 3

Check symptoms when electrical component (headlamps, etc.) switches are operated.

Do symptoms occur?

- YES >> Check if there is a radio, antenna, antenna lead wire, or wiring close to the control unit. If there is, move it farther away.  
NO >> Normal

# VEHICLE JERKS DURING VDC/TCS/ABS CONTROL

< SYMPTOM DIAGNOSIS >

[VDC/TCS/ABS]

## VEHICLE JERKS DURING VDC/TCS/ABS CONTROL

### Diagnosis Procedure

INFOID:000000001537270

#### 1. SYMPTOM CHECK

Check if the vehicle jerks during VDC/TCS/ABS control.

Is the inspection result normal?

- YES >> Normal.
- NO >> GO TO 2

#### 2. CHECK SELF-DIAGNOSIS RESULTS

Perform self-diagnosis of ABS actuator and electric unit (control unit). Refer to [BRC-165, "CONSULT-III Function \(ABS\)"](#).

Are self-diagnosis results indicated?

- YES >> Check corresponding items, make repairs, and perform ABS actuator and electric unit (control unit) self-diagnosis.
- NO >> GO TO 3

#### 3. CHECK CONNECTOR

- Turn ignition switch OFF and disconnect ABS actuator and electric unit (control unit) connector and check terminal for deformation, disconnection, looseness, etc.
- Securely connect connectors and perform ABS actuator and electric unit (control unit) self-diagnosis.

Are self-diagnosis results indicated?

- YES >> If poor contact, damage, open or short circuit of connector terminal is found, repair or replace.
- NO >> GO TO 4

#### 4. CHECK ECM AND TCM SELF-DIAGNOSIS RESULTS

Perform ECM and TCM self-diagnosis.

Are self-diagnosis results indicated?

- YES >> Check the corresponding items.
  - ECM: Refer to [EC-67, "CONSULT-III Function \(ENGINE\)"](#).
  - TCM: Refer to [TM-34, "CONSULT-III Function \(TRANSMISSION\)"](#).
- NO >> Replace ABS actuator and electric unit (control unit). Refer to [BRC-255, "Removal and Installation"](#).

A  
B  
C  
D  
E  
G  
H  
I  
J  
K  
L  
M  
N  
O  
P

BRC

# NORMAL OPERATING CONDITION

< SYMPTOM DIAGNOSIS >

[VDC/TCS/ABS]

## NORMAL OPERATING CONDITION

### Description

INFOID:000000001537271

Symptom	Result
Slight vibrations are felt on the brake pedal and the operation noises occur, when VDC, TCS or ABS is activated.	This is a normal condition due to the VDC, TCS or ABS activation.
Stopping distance is longer than that of vehicles without ABS when the vehicle drives on rough, gravel, or snow-covered (fresh, deep snow) roads.	
The brake pedal moves and generates noises, when TCS or VDC is activated due to rapid acceleration or sharp turn.	
The brake pedal vibrates and motor operation noises occur from the engine room, after the engine starts and just after the vehicle starts.	This is normal, and it is caused by the ABS operation check.
Depending on the road conditions, the driver may experience a sluggish feel.	This is normal, because TCS places the highest priority on the optimum traction (stability).
TCS may activate momentarily if wheel speed changes when driving over location where friction coefficient varies, when downshifting, or when fully depressing accelerator pedal.	
The ABS warning lamp, VDC OFF indicator lamp and SLIP indicator lamp may turn ON when the vehicle is subject to strong shaking or large vibration, such as when the vehicle is rotating on a turntable or located on a ship while the engine is running.	In this case, restart the engine on a normal road. If the normal condition is restored, there is no malfunction. At that time, erase the self-diagnosis memory.
VDC may not operate normally or the ABS warning lamp, VDC OFF indicator lamp, and SLIP indicator lamp may illuminate, when running on a special road that is extremely slanted (e.g. bank in a circuit course).	
A malfunction may occur in the yaw rate/side/decel G sensor system, when the vehicle turns sharply, such as during a spin turn, axle turn, or drift driving, while the VDC function is off (VDC OFF indicator lamp illuminated).	
The vehicle speed will not increase even though the accelerator pedal is depressed, when inspecting the speedometer on a 2-wheel chassis dynamometer.	Normal (Deactivate the VDC/TCS function before performing an inspection on a chassis dynamometer.)
VDC OFF indicator lamp and SLIP indicator lamp may simultaneously turn on when low tire pressure warning lamp turns on.	This is not a VDC system error but results from characteristic change of tire.



PRECAUTION

PRECAUTIONS

Precaution for Supplemental Restraint System (SRS) "AIR BAG" and "SEAT BELT PRE-TENSIONER"

INFOID:000000001537272

The Supplemental Restraint System such as "AIR BAG" and "SEAT BELT PRE-TENSIONER", used along with a front seat belt, helps to reduce the risk or severity of injury to the driver and front passenger for certain types of collision. This system includes seat belt switch inputs and dual stage front air bag modules. The SRS system uses the seat belt switches to determine the front air bag deployment, and may only deploy one front air bag, depending on the severity of a collision and whether the front occupants are belted or unbelted. Information necessary to service the system safely is included in the SR and SB section of this Service Manual.

**WARNING:**

- To avoid rendering the SRS inoperative, which could increase the risk of personal injury or death in the event of a collision which would result in air bag inflation, all maintenance must be performed by an authorized NISSAN/INFINITI dealer.
- Improper maintenance, including incorrect removal and installation of the SRS, can lead to personal injury caused by unintentional activation of the system. For removal of Spiral Cable and Air Bag Module, see the SR section.
- Do not use electrical test equipment on any circuit related to the SRS unless instructed to in this Service Manual. SRS wiring harnesses can be identified by yellow and/or orange harnesses or harness connectors.

Precaution for Brake System

INFOID:000000001537273

**CAUTION:**

- Always use recommended brake fluid. Refer to [MA-10, "Fluids and Lubricants"](#).
- Never reuse drained brake fluid.
- Be careful not to splash brake fluid on painted areas; it may cause paint damage. If brake fluid is splashed on painted areas, wash it away with water immediately.
- To clean or wash all parts of master cylinder and disc brake caliper, use clean brake fluid.
- Never use mineral oils such as gasoline or kerosene. They will ruin rubber parts of the hydraulic system.
- Use flare nut wrench when removing and installing brake tube.
- If a brake fluid leak is found, the part must be disassembled without fail. Then it has to be replaced with a new one if a defect exists.
- Turn the ignition switch OFF and remove the connector of the ABS actuator and electric unit (control unit) or the battery terminal before performing the work.
- Always torque brake lines when installing.
- Burnish the brake contact surfaces after refinishing or replacing rotors, after replacing pads, or if a soft pedal occurs at very low mileage.

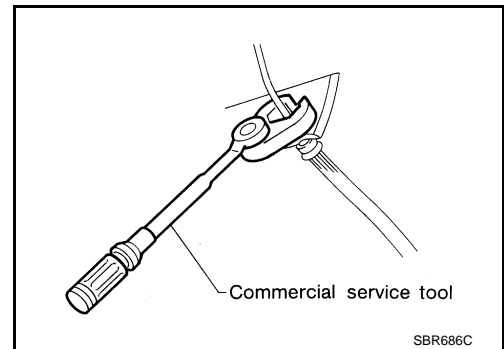

Refer to [BR-35, "Brake Burnishing Procedure"](#) (front disc brake) or [BR-40, "Removal and Installation of Brake Pad"](#) (rear disc brake).

**WARNING:**

- Clean brake pads and shoes with a waste cloth, then wipe with a dust collector.

Precaution for Brake Control

INFOID:000000001537274

- During ABS operation, the brake pedal may vibrate lightly and a mechanical noise may be heard. This is normal.
- Just after starting vehicle, the brake pedal may vibrate or a motor operating noise may be heard from engine compartment. This is a normal status of operation check.
- Stopping distance may be longer than that of vehicles without ABS when vehicle drives on rough, gravel, or snow-covered (fresh, deep snow) roads.

A  
B  
C  
D  
E  
BRC  
G  
H  
I  
J  
K  
L  
M  
N  
O  
P

# PRECAUTIONS

[VDC/TCS/ABS]

## < PRECAUTION >

- When an error is indicated by ABS or another warning lamp, collect all necessary information from customer (what symptoms are present under what conditions) and check for simple causes before starting diagnosis. Besides electrical system inspection, check booster operation, brake fluid level, and fluid leaks.
- If incorrect tire sizes or types are installed on the vehicle or brake pads are not Genuine NISSAN parts, stopping distance or steering stability may deteriorate.
- If there is a radio, antenna or related wiring near control module, ABS function may have a malfunction or error.
- If aftermarket parts (car stereo, CD player, etc.) have been installed, check for incidents such as harness pinches, open circuits or improper wiring.
- If the following components are replaced with non-genuine components or modified, the VDC OFF indicator lamp and SLIP indicator lamp may turn on or the VDC system may not operate properly. Components related to suspension (shock absorbers, struts, springs, bushings, etc.), tires, wheels (exclude specified size), components related to brake system (pads, rotors, calipers, etc.), components related to engine (muffler, ECM, etc.), components related to body reinforcement (roll bar, tower bar, etc.).
- Driving with broken or excessively worn suspension components, tires or brake system components may cause the VDC OFF indicator lamp and the SLIP indicator lamp to turn on, and the VDC system may not operate properly.
- When the TCS or VDC is activated by sudden acceleration or sudden turn, some noise may occur. The noise is a result of the normal operation of the TCS and VDC.
- When driving on roads which have extreme slopes (such as mountainous roads) or high banks (such as sharp curves on a freeway), the VDC may not operate normally, or the VDC warning lamp and the SLIP indicator lamp may turn on. This is not a problem if normal operation can be resumed after restarting the engine.
- Sudden turns (such as spin turns, acceleration turns), drifting, etc. with VDC turned off may cause the yaw rate/side/decel G sensor to indicate a problem. This is not a problem if normal operation can be resumed after restarting the engine.

## Precaution for CAN System

INFOID:000000001537275

- Do not apply voltage of 7.0V or higher to terminal to be measured.
- Maximum open terminal voltage of tester in use must be less than 7.0V.
- Before checking harnesses, turn ignition switch OFF and disconnect battery negative cable.
- Area to be repaired must be soldered and wrapped with tape. Make sure that fraying of twisted wire is within 110 mm (4.33 in).

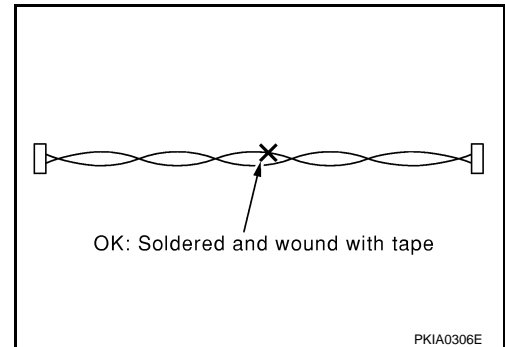

- Do not make a bypass connection to repaired area. (If the circuit is bypassed, characteristics of twisted wire will be lost.)

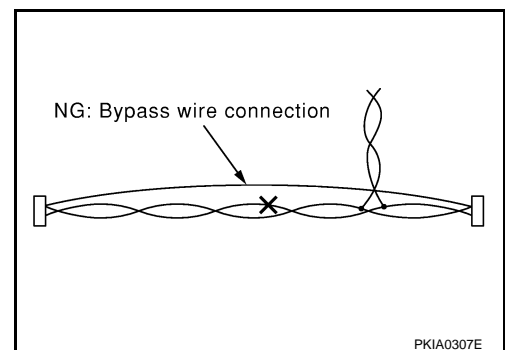

# PREPARATION

< PREPARATION >

[VDC/TCS/ABS]

## PREPARATION

### PREPARATION

#### Special Service Tool

INFOID:000000001537276

The actual shapes of Kent-Moore tools may differ from those of special service tools illustrated here.

Tool number (Kent-Moore No.) Tool name	Description
KV991J0080 (J-45741) ABS active wheel sensor tester	Checking operation of ABS active wheel sensors
ST30031000 ( — ) Bearing puller	Removing sensor rotor
ST30720000 (J-25405) Drift	Installing rear sensor rotor <b>a: 77 mm (0.03 in) dia.</b> <b>b: 55 mm (2.17 in) dia.</b>
ST27863000 ( — ) Drift	Installing rear sensor rotor <b>a: 75 mm (2.95 in) dia.</b> <b>b: 62 mm (2.44 in) dia.</b>
KV40104710 ( — ) Drift	Installing rear sensor rotor <b>a: 76 mm (2.99 in) dia.</b> <b>b: 68.5 mm (2.697 in) dia.</b>

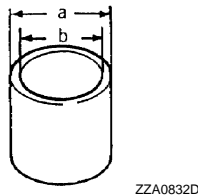
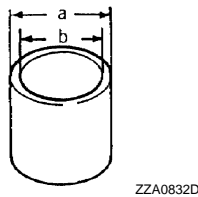
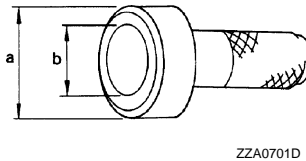
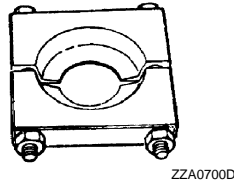
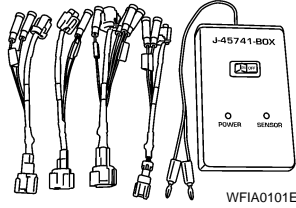

A  
B  
C  
D  
E  
BRC  
G  
H  
I  
J  
K  
L  
M  
N  
O  
P

# PREPARATION

< PREPARATION >

[VDC/TCS/ABS]

## Commercial Service Tool

INFOID:000000001537277

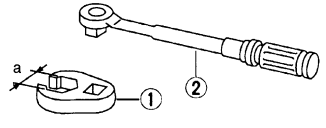
Tool name	Description
<p>1. Flare nut crowfoot 2. Torque wrench</p>  <p>S-NT360</p>	<p>Removing and installing brake piping <b>a: 10 mm (0.39 in)/12 mm (0.47 in)</b></p>

## REMOVAL AND INSTALLATION

### WHEEL SENSORS

#### Removal and Installation

INFOID:000000001537280

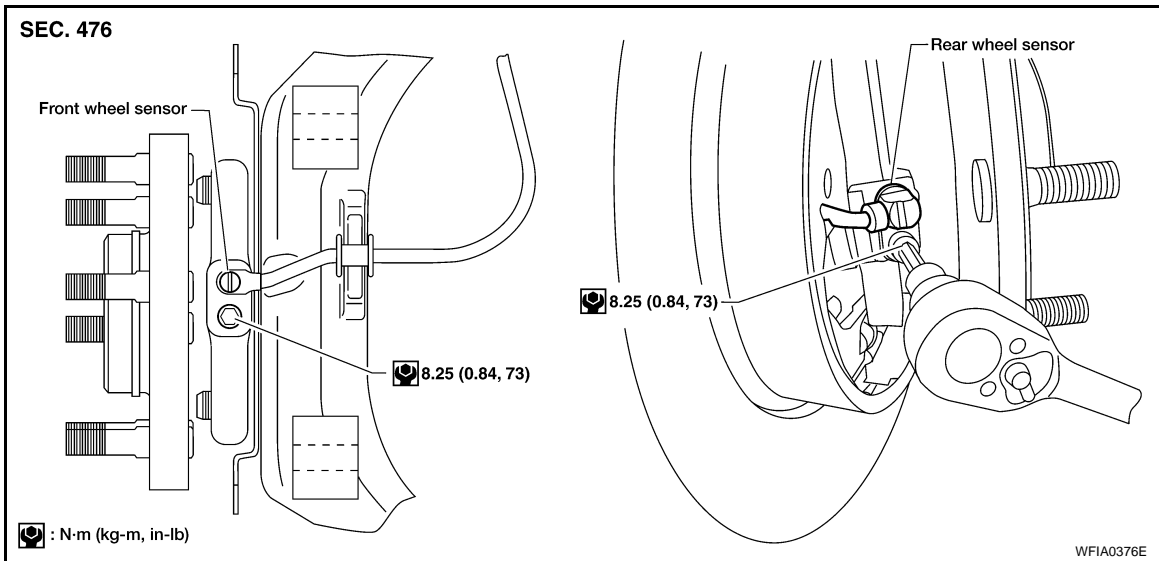

#### REMOVAL

1. Remove wheel sensor bolt.
  - When removing the front wheel sensor, first remove the disc rotor to gain access to the front wheel sensor bolt. Refer to [BR-34. "Removal and Installation of Brake Caliper and Disc Rotor"](#).
2. Pull out the sensor, being careful to turn it as little as possible.
 

**CAUTION:**

  - **Do not pull on the sensor harness.**
3. Disconnect wheel sensor harness electrical connector, then remove harness from attaching points.

#### INSTALLATION

Installation is in the reverse order of removal. Tighten wheel sensor bolt to specification.

**CAUTION:**

Installation should be performed while paying attention to the following.

- Inspect wheel sensor O-ring, replace sensor assembly if damaged.
- Before installing wheel sensor, make sure no foreign materials (such as iron fragments) are adhered to the pick-up part of the sensor, to the inside of the sensor hole or on the rotor mating surface.
- Apply a coat of suitable grease to the wheel sensor O-ring and hole. Refer to [GI-15](#).

# SENSOR ROTOR

< REMOVAL AND INSTALLATION >

[VDC/TCS/ABS]

---

## SENSOR ROTOR

### Removal and Installation

INFOID:000000001537281

**NOTE:**

The front wheel sensor rotors are built into the wheel hubs and are not removable. If damaged, replace wheel hub and bearing assembly. Refer to [FAX-6, "Removal and Installation"](#). Remove the rear axle refer to [RAX-8, "Removal and Installation"](#).

# ACTUATOR AND ELECTRIC UNIT (ASSEMBLY)

< REMOVAL AND INSTALLATION >

[VDC/TCS/ABS]

## ACTUATOR AND ELECTRIC UNIT (ASSEMBLY)

### Removal and Installation

INFOID:000000001537282

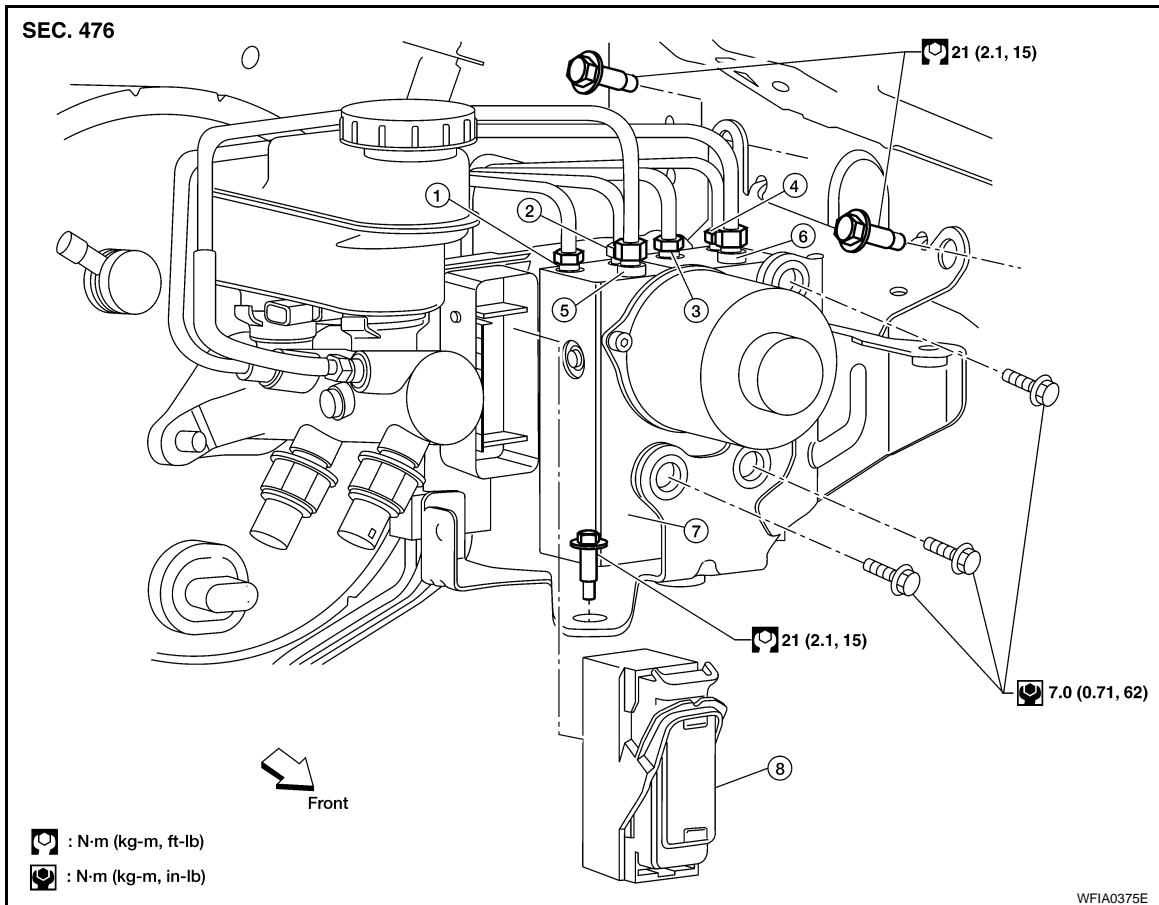

- |  |  |  |
|--|--|--|
| 1. To left front                                 | 2. To rear right                           | 3. To rear left                          |
| 4. To front right                                | 5. From the master cylinder secondary side | 6. From the master cylinder primary side |
| 7. ABS actuator and electric unit (control unit) | 8. Harness connector                       |  |

### REMOVAL

1. Disconnect the negative battery terminal.
2. Remove the cowl top extension. Refer to [EXT-19. "Removal and Installation"](#).
3. Drain the brake fluid. Refer to [BR-16. "Drain and Refill"](#).
4. Disconnect the actuator harness from the ABS actuator and electric unit (control unit).

#### CAUTION:

- To remove the brake tubes, use a flare nut wrench to prevent the flare nuts and brake tubes from being damaged.
- Be careful not to splash brake fluid on painted areas.

5. Disconnect the brake tubes.
6. Remove the three bolts and remove the ABS actuator and electric unit (control unit).

### INSTALLATION

Installation is in the reverse order of removal.

#### CAUTION:

To install, use a flare nut wrench (commercial service tool).

- Always tighten brake tubes to specification when installing. Refer to [BR-12. "Hydraulic Circuit"](#).
- Never reuse drained brake fluid.

A

B

C

D

E

BRC

G

H

I

J

K

L

M

N

O

P

## ACTUATOR AND ELECTRIC UNIT (ASSEMBLY)

< REMOVAL AND INSTALLATION >

[VDC/TCS/ABS]

- After installation of the ABS actuator and electric unit (control unit), perform the following.
- Refill brake system with new brake fluid. Then bleed the air from the system. Refer to [BR-16, "Bleeding Brake System"](#) .
- Adjust the steering angle sensor. Refer to [BRC-150, "ADDITIONAL SERVICE WHEN REPLACING CONTROL UNIT : Description"](#).
- Calibrate the decel G sensor. Refer to [BRC-151, "CALIBRATION OF DECEL G SENSOR : Description"](#).



# STEERING ANGLE SENSOR

< REMOVAL AND INSTALLATION >

[VDC/TCS/ABS]

## STEERING ANGLE SENSOR

### Removal and Installation

INFOID:000000001537283

The steering angle sensor is an integral part of the spiral cable. Refer to [SR-6, "Removal and Installation"](#).

**CAUTION:**

After installation of spiral cable, adjust steering angle sensor. Refer to [BRC-150, "ADJUSTMENT OF STEERING ANGLE SENSOR NEUTRAL POSITION : Description"](#).

A  
B  
C  
D  
E  
G  
H  
I  
J  
K  
L  
M  
N  
O  
P

**BRC**

## G SENSOR

### Removal and Installation

INFOID:000000001537284

#### REMOVAL

1. Remove center console. Refer to [IP-18. "Removal and Installation"](#).
2. Remove yaw rate/side/decel G sensor attaching nuts.  
**CAUTION:**
  - Do not use power tools to remove or install yaw rate/side/decel G sensor.
  - Do not drop or strike the yaw rate/side/decel G sensor.
3. Disconnect harness connector and remove the yaw rate/side/decel G sensor.

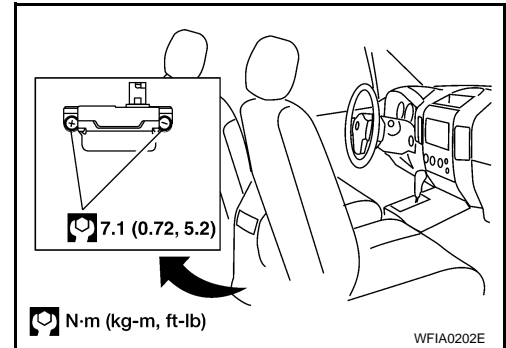

#### INSTALLATION

Installation is in the reverse order of removal.

#### **CAUTION:**

- Do not drop or strike the yaw rate/side/decel G sensor.
- After installation, calibrate the yaw rate/side/decel G sensor. Refer to [BRC-151. "CALIBRATION OF DECEL G SENSOR : Description"](#).