

SECTION **ST**
STEERING SYSTEM

A
 B
 C
 D
 E
 F
ST
 H
 I
 J
 K
 L
 M
 N
 O
 P

CONTENTS

<p>PRECAUTION 2</p> <p>PRECAUTIONS 2</p> <p style="padding-left: 20px;">Precaution for Supplemental Restraint System (SRS) "AIR BAG" and "SEAT BELT PRE-TENSIONER"2</p> <p style="padding-left: 20px;">Precaution for Steering System2</p> <p>PREPARATION 3</p> <p>PREPARATION 3</p> <p style="padding-left: 20px;">Special Service Tool3</p> <p style="padding-left: 20px;">Commercial Service Tool5</p> <p>SYMPTOM DIAGNOSIS 6</p> <p>NOISE, VIBRATION, AND HARSHNESS (NVH) TROUBLESHOOTING 6</p> <p style="padding-left: 20px;">NVH Troubleshooting Chart6</p> <p>ON-VEHICLE MAINTENANCE 7</p> <p>POWER STEERING FLUID 7</p> <p style="padding-left: 20px;">Checking Fluid Level7</p> <p style="padding-left: 20px;">Checking Fluid Leakage7</p> <p style="padding-left: 20px;">Air Bleeding Hydraulic System7</p> <p>ON-VEHICLE REPAIR 9</p> <p>STEERING WHEEL 9</p> <p style="padding-left: 20px;">On-Vehicle Inspection and Service9</p> <p>POWER STEERING OIL PUMP11</p> <p style="padding-left: 20px;">On-Vehicle Inspection and Service 11</p> <p>REMOVAL AND INSTALLATION12</p>	<p>STEERING WHEEL12</p> <p style="padding-left: 20px;">Removal and Installation12</p> <p>STEERING COLUMN13</p> <p style="padding-left: 20px;">Removal and Installation13</p> <p>POWER STEERING GEAR AND LINKAGE17</p> <p style="padding-left: 20px;">Removal and Installation17</p> <p>POWER STEERING OIL PUMP20</p> <p style="padding-left: 20px;">Removal and Installation20</p> <p>HYDRAULIC LINE21</p> <p style="padding-left: 20px;">Removal and Installation21</p> <p>DISASSEMBLY AND ASSEMBLY23</p> <p>STEERING COLUMN23</p> <p style="padding-left: 20px;">Disassembly and Assembly23</p> <p>POWER STEERING GEAR AND LINKAGE26</p> <p style="padding-left: 20px;">Disassembly and Assembly26</p> <p>POWER STEERING OIL PUMP29</p> <p style="padding-left: 20px;">Disassembly and Assembly29</p> <p>SERVICE DATA AND SPECIFICATIONS (SDS)30</p> <p>SERVICE DATA AND SPECIFICATIONS (SDS)30</p> <p style="padding-left: 20px;">Steering Wheel30</p> <p style="padding-left: 20px;">Steering Column30</p> <p style="padding-left: 20px;">Steering Outer Socket and Inner Socket31</p> <p style="padding-left: 20px;">Steering Gear32</p> <p style="padding-left: 20px;">Oil Pump32</p> <p style="padding-left: 20px;">Steering Fluid32</p>
-------------------------------------------------------------------------------------------------------------------------------------------------------------------------------------------------------------------------------------------------------------------------------------------------------------------------------------------------------------------------------------------------------------------------------------------------------------------------------------------------------------------------------------------------------------------------------------------------------------------------------------------------------------------------------------------------------------------------------------------------------------------------------------------------------------------------------------------------------------------------------------------------------------------------------------------------------------------------------------------------------------------------------------------------------------------------------------------------------------------------------------------------------------------------------------------------------------------------------------------------------------------------------------------------------------------	----------------------------------------------------------------------------------------------------------------------------------------------------------------------------------------------------------------------------------------------------------------------------------------------------------------------------------------------------------------------------------------------------------------------------------------------------------------------------------------------------------------------------------------------------------------------------------------------------------------------------------------------------------------------------------------------------------------------------------------------------------------------------------------------------------------------------------------------------------------------------------------------------------------------------------------------------------------------------------------------------------------------------------------------------------------------------------------------------------------------------------------------------------------------------------------------------------------------------------------------------------------------------------------------------------------------------------------------------------------------------------------------------------------------------------------------------------------------------------

PRECAUTIONS

< PRECAUTION >

PRECAUTION

PRECAUTIONS

Precaution for Supplemental Restraint System (SRS) "AIR BAG" and "SEAT BELT PRE-TENSIONER"

INFOID:000000001349102

The Supplemental Restraint System such as "AIR BAG" and "SEAT BELT PRE-TENSIONER", used along with a front seat belt, helps to reduce the risk or severity of injury to the driver and front passenger for certain types of collision. This system includes seat belt switch inputs and dual stage front air bag modules. The SRS system uses the seat belt switches to determine the front air bag deployment, and may only deploy one front air bag, depending on the severity of a collision and whether the front occupants are belted or unbelted. Information necessary to service the system safely is included in the SR and SB section of this Service Manual.

WARNING:

- **To avoid rendering the SRS inoperative, which could increase the risk of personal injury or death in the event of a collision which would result in air bag inflation, all maintenance must be performed by an authorized NISSAN/INFINITI dealer.**
- **Improper maintenance, including incorrect removal and installation of the SRS, can lead to personal injury caused by unintentional activation of the system. For removal of Spiral Cable and Air Bag Module, see the SR section.**
- **Do not use electrical test equipment on any circuit related to the SRS unless instructed to in this Service Manual. SRS wiring harnesses can be identified by yellow and/or orange harnesses or harness connectors.**

Precaution for Steering System

INFOID:000000001349103

- Before disassembly, thoroughly clean the outside of the unit.
- Disassembly should be done in a clean work area. It is important to prevent the internal parts from becoming contaminated by dirt or other foreign matter.
- For easier and proper assembly, place disassembled parts in order on a parts rack.
- Use nylon cloth or paper towels to clean the parts; common shop rags can leave lint that might interfere with their operation.
- Before inspection or reassembly, carefully clean all parts with a general purpose, non-flammable solvent.
- Before assembly, apply a coat of recommended Genuine NISSAN PSF or equivalent to hydraulic parts. Petroleum jelly may be applied to O-rings and seals. Do not use any grease.
- Replace all gaskets, seals and O-rings. Avoid damaging O-rings, seals and gaskets during installation. Perform functional tests whenever designated.

PREPARATION

< PREPARATION >

PREPARATION

PREPARATION

Special Service Tool

INFOID:000000001349104

The actual shapes of Kent-Moore tools may differ from those of special service tools illustrated here.

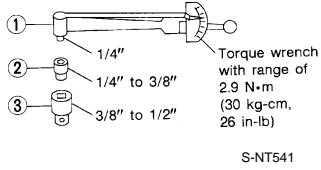
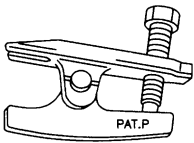
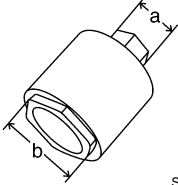
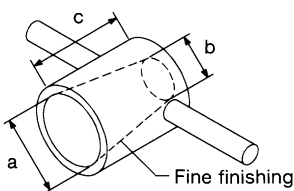
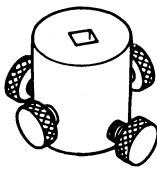
Tool number (Kent-Moore No.) Tool name	Description
ST3127 S000 (See J-25765-A) Preload gauge 1. GG9103000 (J-25765-A) Torque wrench 2. HT62940000 (—) Socket adapter 3. HT62900000 (—) Socket adapter	Inspecting of pinion rotating torque and rotational torque for ball joint  <p style="text-align: right;">S-NT541</p>
HT72520000 (J-25730-A) Ball joint remover	Removing steering outer socket  <p style="text-align: right;">NT146</p>
— (J-46213) Rear cover wrench	Removing rear cover a: 21.6 mm (0.850 in) b: 34.9 mm (1.374 in)  <p style="text-align: right;">SGIA0516E</p>
KV48104400 (—) Teflon ring correcting tool	Installing of rack Teflon ring a: 50 mm (1.97 in) dia. b: 36 mm (1.42 in) dia. c: 100 mm (3.94 in)  <p style="text-align: right;">S-NT550</p>
KV48103400 (—) Torque adapter	Inspecting rotational torque  <p style="text-align: right;">ZZA0824D</p>

A

B

C

D

E

F

ST

H

I

J

K

L

M

N

O

P

PREPARATION

< PREPARATION >

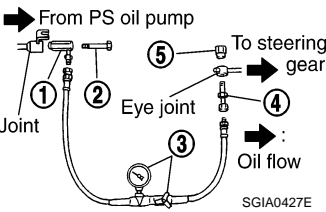
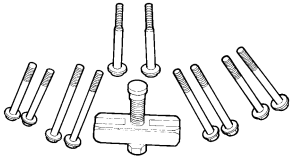
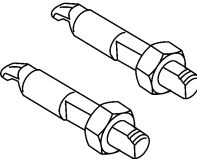
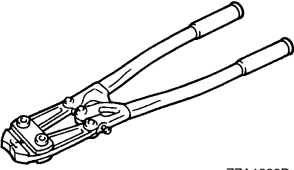
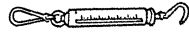
Tool number (Kent-Moore No.) Tool name	Description
1. KV48105300-4 and 5295262U10 (—) Connector A and O-ring 2. KV48105300-3 and 5295262U00 (—) Eye-bolt and O-ring 3. KV48103500 (J-26357 and J-26357-10) Pressure gauge and shut-off valve 4. KV48105300-1 and 5295262U00 (—) Connector B and O-ring 5. KV48105300-2 (—) Nut	
KV481J0010 (J-1859-A) Steering wheel puller	 <p style="text-align: center;">LHIA0043E</p>
KV481J0020 (J-42578) Steering wheel puller legs	 <p style="text-align: center;">LHIA0044E</p>
KV40107300 (—)	 <p style="text-align: center;">ZZA1229D</p>
— (J-44372) Spring gauge	 <p style="text-align: center;">LST024</p>

PREPARATION

< PREPARATION >

Commercial Service Tool

INFOID:000000001349105

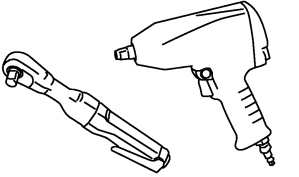
Tool name	Description
<p data-bbox="164 289 277 317">Power tool</p>  <p data-bbox="852 506 922 527">PBIC0190E</p>	<p data-bbox="1015 289 1263 317">Removing nuts and bolts</p>

A

B

C

D

E

F

ST

H

I

J

K

L

M

N

O

P

NOISE, VIBRATION, AND HARSHNESS (NVH) TROUBLESHOOTING

< SYMPTOM DIAGNOSIS >

SYMPTOM DIAGNOSIS

NOISE, VIBRATION, AND HARSHNESS (NVH) TROUBLESHOOTING

NVH Troubleshooting Chart

INFOID:000000001349110

Use chart below to help you find the cause of the symptom. If necessary, repair or replace these parts.

Symptom	Possible cause and suspected parts											Reference page																			
	Noise	Shake	Vibration	Shimmy	Shudder	Fluid level	Air in hydraulic system	Outer socket ball joint swinging force	Outer socket ball joint rotating torque	Outer socket ball joint end play	Steering fluid leakage		Steering wheel play	Steering wheel turning force	Drive belt looseness	Improper steering wheel	Improper installation or looseness of tilt lock lever	Mounting rubber deterioration	Steering column deformation or damage	Improper installation or looseness of steering column	Steering linkage looseness	PROPELLER SHAFT	FRONT FINAL DRIVE	WHEEL HUB	SUSPENSION	TIRES	ROAD WHEEL	DRIVE SHAFT	BRAKES		
	x					x	x	x	x	x	x	x	x	x																	ST-7
	x					x																								ST-7	
	x					x																								ST-31	
	x					x																								ST-31	
	x					x																								ST-31	
	x					x																								ST-7	
	x					x																								ST-9	
	x					x																								ST-9	
	x					x																								EM-12, "Checking Drive Belts"	
		x																												ST-9	
		x																												ST-23	
		x																												ST-17	
			x																											ST-13	
				x																										ST-13	
					x																									ST-17	
						x																								DLN-122 (2F1310), DLN-130 (2S1350), DLN-139 (2S1410), DLN-148 (3S1350), DLN-157 , (3S1410)	
																														DLN-172, "NVH Troubleshooting Chart"	
																														FAX-4, "NVH Troubleshooting Chart"	
																														FSU-4, "NVH Troubleshooting Chart"	
																														WT-31, "NVH Troubleshooting Chart"	
																														WT-31, "NVH Troubleshooting Chart"	
																														FAX-4, "NVH Troubleshooting Chart"	
																														BR-5, "NVH Troubleshooting Chart"	

x: Applicable

POWER STEERING FLUID

< ON-VEHICLE MAINTENANCE >

ON-VEHICLE MAINTENANCE

POWER STEERING FLUID

Checking Fluid Level

INFOID:000000001349111

Check fluid level, referring to the scale on reservoir tank.
Use HOT range for fluid temperatures of 50° – 80°C (122° – 176°F).
Use COLD range for fluid temperatures of 0° – 30°C (32° – 86°F).

CAUTION:

- Do not overfill.
- Do not reuse any used power steering fluid.
- Recommended fluid is Genuine NISSAN PSF or equivalent. Refer to [MA-10, "Fluids and Lubricants"](#).

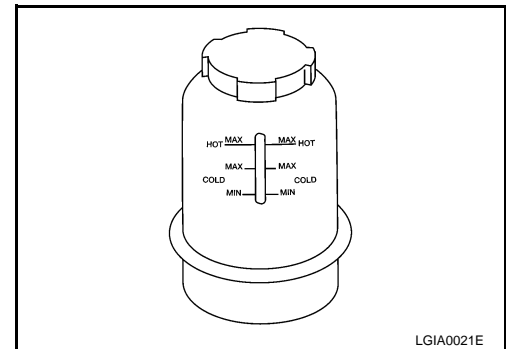

Checking Fluid Leakage

INFOID:000000001349112

Check the hydraulic piping lines for improper attachment and for leaks, cracks, damage, loose connections, chafing or deterioration.

1. Run engine until fluid temperature reaches 50° – 80°C (122° – 176°F) in reservoir tank. Keep engine speed idle.
2. Turn steering wheel right-to-left several times.
3. Hold steering wheel at each "lock" position for five seconds to check fluid leakage.

CAUTION:

Do not hold steering wheel in a locked position for more than 10 seconds. (There is the possibility that oil pump may be damaged.)

4. If fluid leakage at connections is noticed, then loosen flare nut and then retighten. Do not over tighten connector as this can damage O-ring, washer and connector.
5. If fluid leakage from oil pump is noticed, check oil pump. Refer to [ST-11](#).
6. Check steering gear boots for accumulation of fluid indicating a leak from the steering gear.

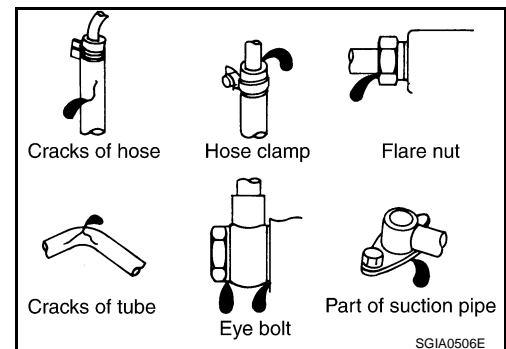

Air Bleeding Hydraulic System

INFOID:000000001349113

Incomplete air bleeding causes the following. When this happens, bleed air again.

- Air bubbles in reservoir tank.
- Clicking noise in oil pump.
- Excessive buzzing in oil pump.

NOTE:

When vehicle is stationary or while steering wheel is being turned slowly, some noise may be heard from oil pump or gear. This noise is normal and does not affect any system.

1. Stop engine, and then turn steering wheel fully to right and left several times.

CAUTION:

Do not allow steering fluid reservoir tank to go below the MIN level line. Check tank frequently and add fluid as needed.

2. Run engine at idle speed. Turn steering wheel fully right and then fully left, hold for about three seconds. Then check for fluid leakage.
3. Repeat step 2 several times at about three second intervals.

CAUTION:

Do not hold steering wheel in the locked position for more than 10 seconds. (There is the possibility that oil pump may be damaged.)

4. Check for air bubbles or cloudy fluid.
5. If air bubbles or cloudiness still exists, stop engine, perform steps 2 and 3 again until air bubbles or cloudiness does not exist.

POWER STEERING FLUID

< ON-VEHICLE MAINTENANCE >

6. Stop engine, check fluid level.

STEERING WHEEL

< ON-VEHICLE REPAIR >

ON-VEHICLE REPAIR

STEERING WHEEL

On-Vehicle Inspection and Service

INFOID:000000001349114

CHECKING CONDITION OF INSTALLATION

- Check installation condition of steering gear assembly, front suspension, axle and steering column.
- Check if movement exists when steering wheel is moved up and down, to the left and right and to the axial direction.

End play of the axial direction for steering wheel : 0 mm (0 in)

- Check if the mounting nuts for steering gear assembly are loose. Refer to [ST-17](#).

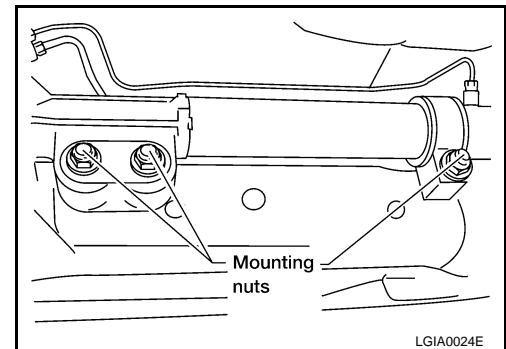

CHECKING STEERING WHEEL PLAY

1. Turn tires straight ahead, start engine, then turn steering wheel to the left and right lightly, and measure steering wheel movement on the outer circumference when steering wheel is turned up to the point where tires start moving.

Steering wheel play on the outer circumference : 0 – 35 mm (0 – 1.38 in)

CHECKING NEUTRAL POSITION ON STEERING WHEEL

- Check neutral position on steering wheel after confirming that front wheel alignment is correct. Refer to [FSU-5, "Front Wheel Alignment"](#).
1. Turn tires straight ahead, check if steering wheel is in the neutral position.
 2. If it is not in the neutral position, remove steering wheel and reinstall it correctly.
 3. If the neutral position cannot be attained by repositioning the steering wheel two teeth or less on steering stem, loosen tie-rod lock nuts of steering outer sockets, then adjust tie-rods by the same amount in the opposite direction.

CHECKING STEERING WHEEL TURNING FORCE

1. Park vehicle on a level, dry surface and set parking brake.
2. Start engine.
3. Bring power steering fluid up to operating temperature of 60° – 80°C (140° – 176°F).
4. Tires need to be inflated to specified pressure. Refer to [WT-39, "Tire"](#).
5. Check steering wheel turning force using Tool when steering wheel has been turned 360° from the neutral position.

Tool number : J-44372

Steering wheel : 39 N (4 kg-f, 9 lb-f) or less turning force

6. If steering wheel turning force is out of specification, inspect steering column. Refer to [ST-13, "Removal and Installation"](#).

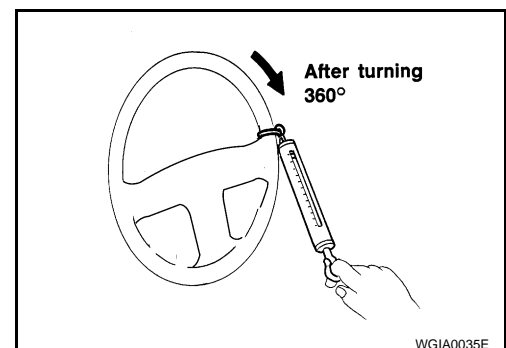

STEERING WHEEL

< ON-VEHICLE REPAIR >

7. If steering column meets specification, repair steering gear. Refer to [ST-23. "Disassembly and Assembly"](#)

CHECKING FRONT WHEEL TURNING ANGLE

When checking front wheel turning angle, refer to [FSU-5. "Front Wheel Alignment"](#).

POWER STEERING OIL PUMP

< ON-VEHICLE REPAIR >

POWER STEERING OIL PUMP

On-Vehicle Inspection and Service

INFOID:000000001349116

CHECKING RELIEF OIL PRESSURE

CAUTION:

Before starting work, confirm belt tension is proper.

1. Connect Tool between oil pump discharge connector and high pressure hose and then bleed air from the hydraulic circuit.

Tool number:		
Pressure gauge and shut-off valve		KV48103500 (J26357 and J26357-10)
Oil pump side	Connector A and O-ring	KV48105300-4 and 5295262U10 (—)
	Eye-bolt and O-ring	KV48105300-3 and 5295262U00 (—)
High pressure piping side	Connector B and O-ring	KV48105300-1 and 5295262U00 (—)
	Nut	KV48105300-2 (—)

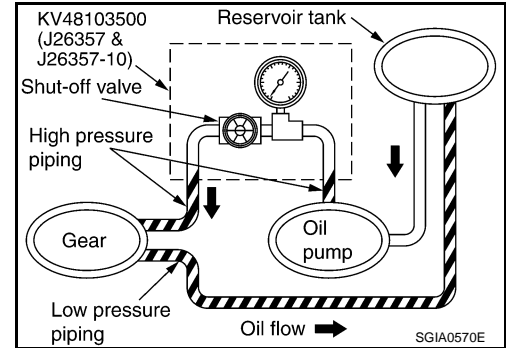

2. Start engine. Allow engine to run until tank temperature reaches 50 – 80°C (122 – 176°F).

CAUTION:

- Warm up engine with shut-off valve fully opened. If engine is started with shut-off valve closed, fluid pressure in power steering pump increases to maximum. This will raise fluid temperature excessively.
- Be careful not to contact hose with belt when engine is started.

3. With engine at idle, close shut-off valve and read the relief oil pressure.

Relief oil pressure : 9.0 – 9.8 mPa (91.77 – 99.93 kg/cm², 1305.34 – 1421.37 psi)

CAUTION:

Do not close shut-off valve of pressure gauge for more than 10 seconds.

4. After measurement, open shut-off valve slowly.
 - If relief oil pressure is outside the specification, disassemble and repair oil pump. Refer to [ST-26, "Dis-assembly and Assembly"](#).
5. After inspection, disconnect oil pressure gauge and oil pressure gauge adapter from hydraulic circuit, connect oil pump discharge connector and high pressure hose. Add fluid and bleed air from hydraulic circuit thoroughly. Refer to [ST-7, "Air Bleeding Hydraulic System"](#).

STEERING WHEEL

< REMOVAL AND INSTALLATION >

REMOVAL AND INSTALLATION

STEERING WHEEL

Removal and Installation

INFOID:000000001349120

REMOVAL

1. Set the front wheels in the straight-ahead position.
2. Remove the driver air bag module. Refer to [SR-4, "Removal and Installation"](#).
3. Disconnect steering wheel switches.
4. Remove the steering wheel center nut.
5. Remove the steering wheel using Tools.

Tool number **A:** KV481J0010 (J-1859-A)
 B: KV481J0020 (J-42578)

CAUTION:

Place a piece of tape across the spiral cable so it will not be rotated out of position.

6. Inspect the steering wheel near the puller holes for damage. If damaged, replace the steering wheel.
 - Remove steering wheel rear cover and steering wheel switches, if required.

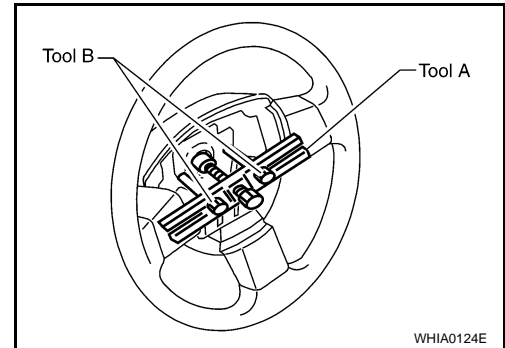

INSTALLATION

Installation is in the reverse order of removal.

- Align spiral cable correctly when installing steering wheel. Make sure that the spiral cable is in the neutral position. The neutral position is detected by turning left 2.6 revolutions from the right end position and ending with the knob at the top.
- If equipped with VDC, refer to [BRC-150, "ADJUSTMENT OF STEERING ANGLE SENSOR NEUTRAL POSITION : Special Repair Requirement"](#) for steering angle sensor adjustment.
- After the work is completed, perform self-diagnosis to make sure no malfunction is detected. Refer to [SRC-13, "SRS Operation Check"](#).
- Tighten steering wheel center nut to specification. Refer to [ST-12, "Removal and Installation"](#).

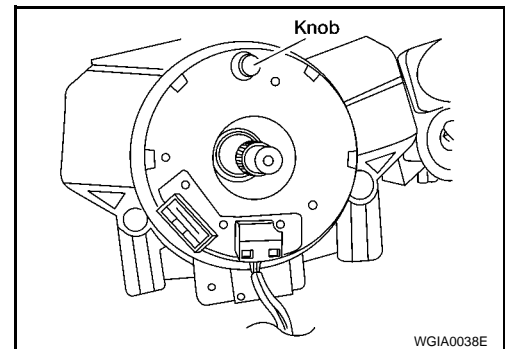

CAUTION:

- The spiral cable may snap due to steering operation if the cable is not installed in the correct position.
- With the steering linkage disconnected, the cable may snap by turning the steering wheel beyond the limited number of turns. The spiral cable can be turned counterclockwise about 2.5 turns from the neutral position.

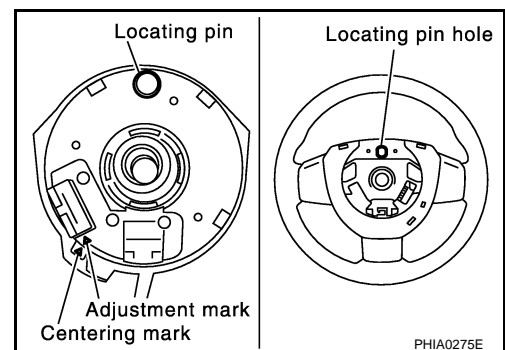

STEERING COLUMN

< REMOVAL AND INSTALLATION >

STEERING COLUMN

Removal and Installation

INFOID:000000001349121

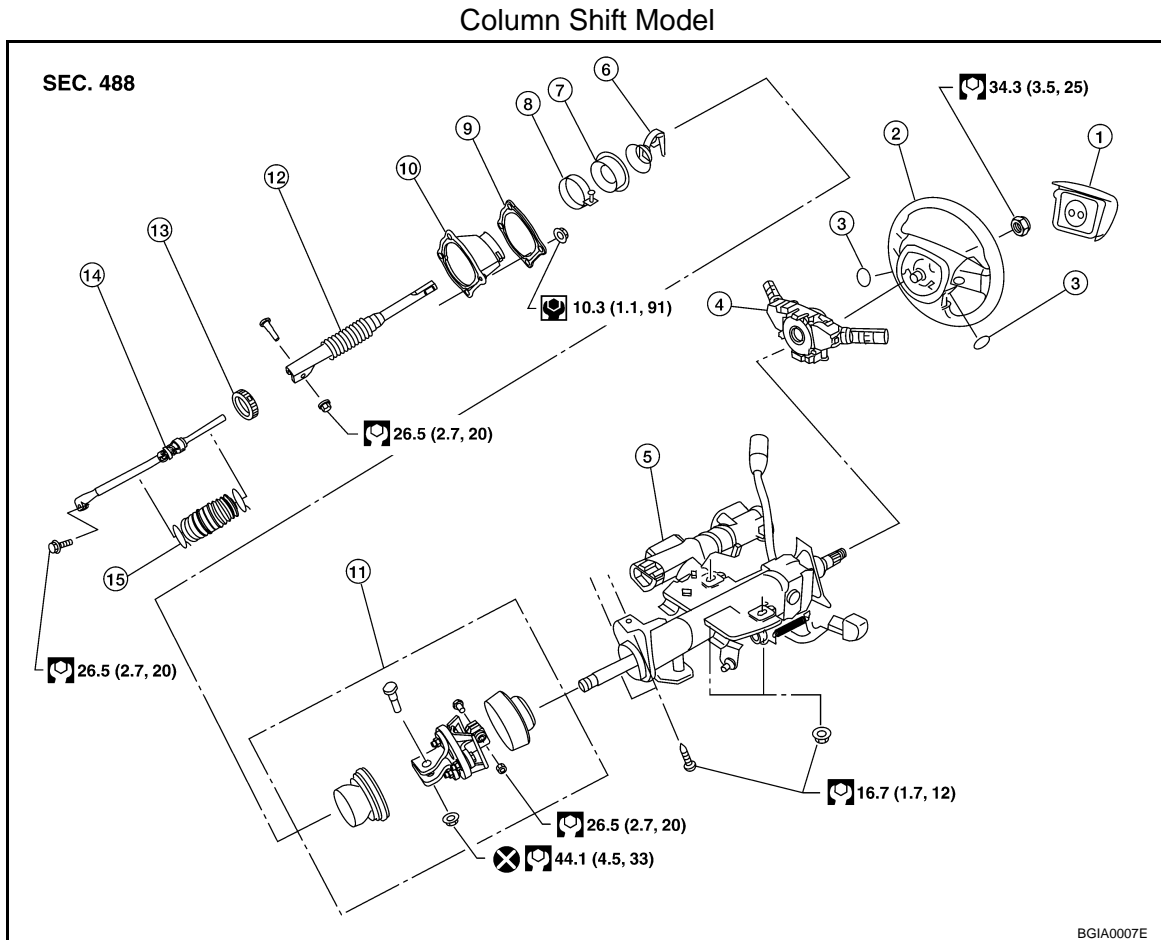

- | | | |
|----------------------------------------|-----------------------------|------------------------------|
| 1. Driver air bag module | 2. Steering wheel | 3. Steering wheel side cover |
| 4. Combination switch and spiral cable | 5. Steering column assembly | 6. Collar |
| 7. Hole cover seal | 8. Clamp | 9. Hole cover mounting plate |
| 10. Hole cover | 11. Upper joint | 12. Upper shaft |
| 13. Boot clamp | 14. Lower joint shaft | 15. Boot and clips (plastic) |

STEERING COLUMN

< REMOVAL AND INSTALLATION >

Floor Shift Model

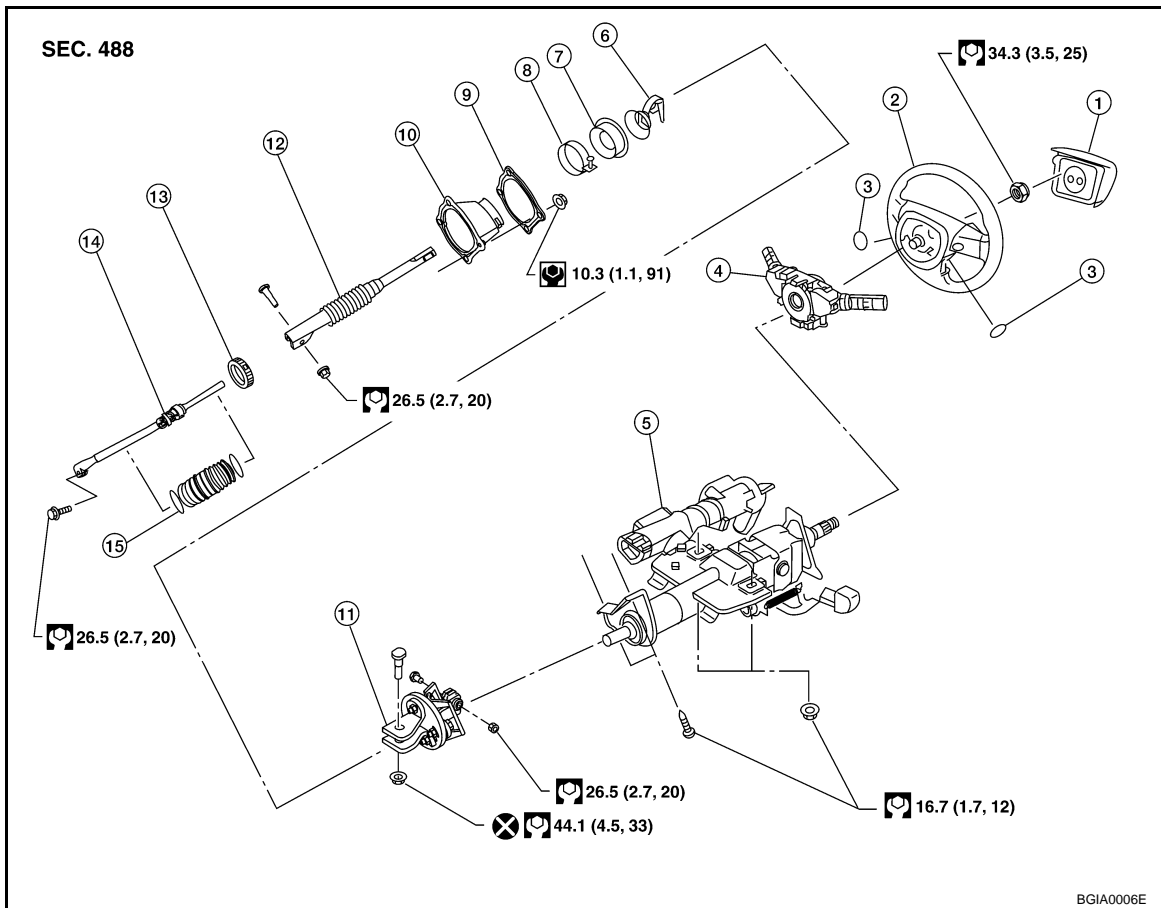

- | | | |
|----------------------------------------|-----------------------------|------------------------------|
| 1. Driver air bag module | 2. Steering wheel | 3. Steering wheel side cover |
| 4. Combination switch and spiral cable | 5. Steering column assembly | 6. Collar |
| 7. Hole cover seal | 8. Clamp | 9. Hole cover mounting plate |
| 10. Hole cover | 11. Upper joint | 12. Upper shaft |
| 13. Boot clamp | 14. Lower joint shaft | 15. Boot and clips (plastic) |

CAUTION:

- Care must be taken not to give axial impact to steering column assembly during removal and installation.
- Care must be taken not to move steering gear during removal of steering column assembly.

REMOVAL

1. Remove spiral cable from steering column assembly with combination switches attached. Refer to [SR-6. "Removal and Installation"](#).

2. Remove tilt lever knob from tilt lever by inserting a suitable tool into slot of tilt lever knob, then depress tab and withdraw tilt lever knob.

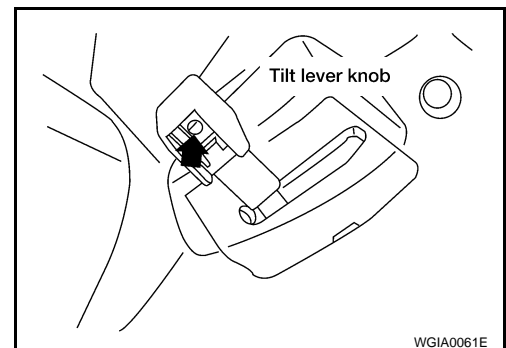

3. Remove lower driver instrument panel. Refer to [IP-16. "Removal and Installation"](#).
4. Remove steering column cover and ignition key finisher. Refer to [IP-11. "Removal and Installation"](#).

STEERING COLUMN

< REMOVAL AND INSTALLATION >

5. Remove knee protector screws, then remove knee protector from vehicle.

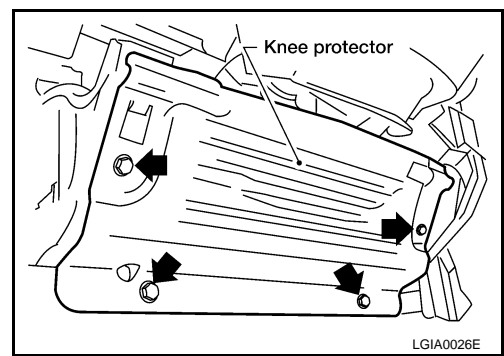

6. On models equipped with column shift, disconnect shift cable from steering column. Refer to [TM-215, "Control Device Removal and Installation"](#).
7. Remove lock nut and bolt, then separate lower joint from upper joint.

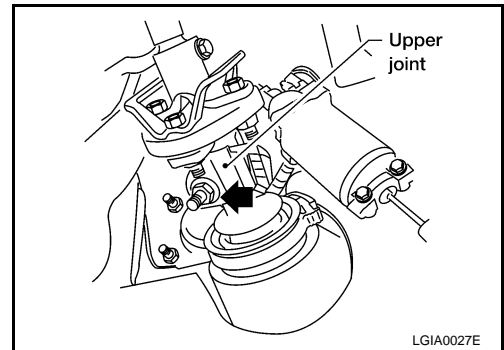

8. Remove steering member nuts, then remove steering column assembly from steering member.

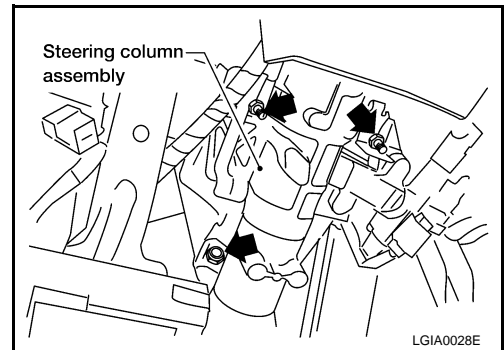

9. Remove hole cover seal and clamp.
10. Remove nuts, then remove hole cover from dash panel.
11. Raise vehicle, then remove bolt (lower side) of lower joint and remove lower joint from vehicle.

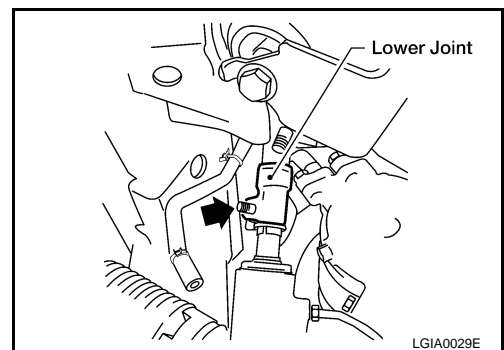

INSPECTION AFTER REMOVAL

- Check for damage to steering column jacket tube. If damage is found, replace steering column with new one.

STEERING COLUMN

< REMOVAL AND INSTALLATION >

- If vehicle has been in a collision, check column length "L¹" or "L²" as shown. If out of specification, replace steering column with new one.

Steering column length

L¹ : 158 mm (6.22 in)

L² : 262 mm (10.31 in)

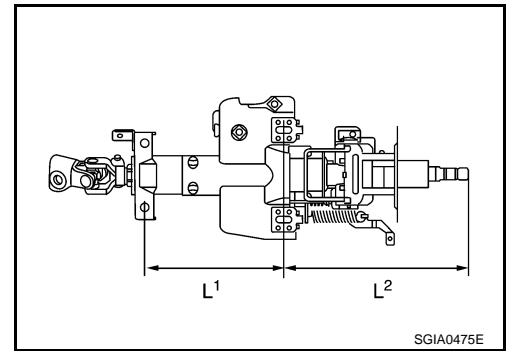

- Check for proper lubrication, apply grease as necessary.

INSTALLATION

Installation is in the reverse order of removal.

CAUTION:

When installing the steering column, finger-tighten all of the lower bracket and joint retaining bolts; then tighten them to specification. Do not apply undue stress to the steering column.

NOTE:

Align slit of the coupling joint with projection on dust cover. Insert the joint until surface "A" contacts surface "B".

- After installation, turn steering wheel to make sure it moves smoothly. Make sure the number of turns are the same from the straight-forward position to left and right locks. Make sure that the steering wheel is in a neutral position when driving straight ahead.
- When installing steering column to steering member, install nut from front side of vehicle.

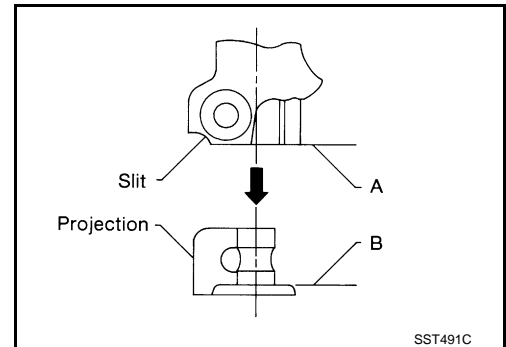

INSPECTION AFTER INSTALLATION

- After installing steering column to vehicle, check tilt device and its operation range is as specified.

Range "A" : 61.3 mm (2.41 in)

- Check if steering wheel operation can turn to the end of the left and right stops smoothly.

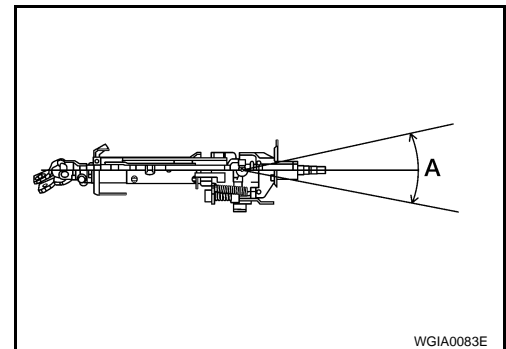

POWER STEERING GEAR AND LINKAGE

< REMOVAL AND INSTALLATION >

POWER STEERING GEAR AND LINKAGE

Removal and Installation

INFOID:000000001349123

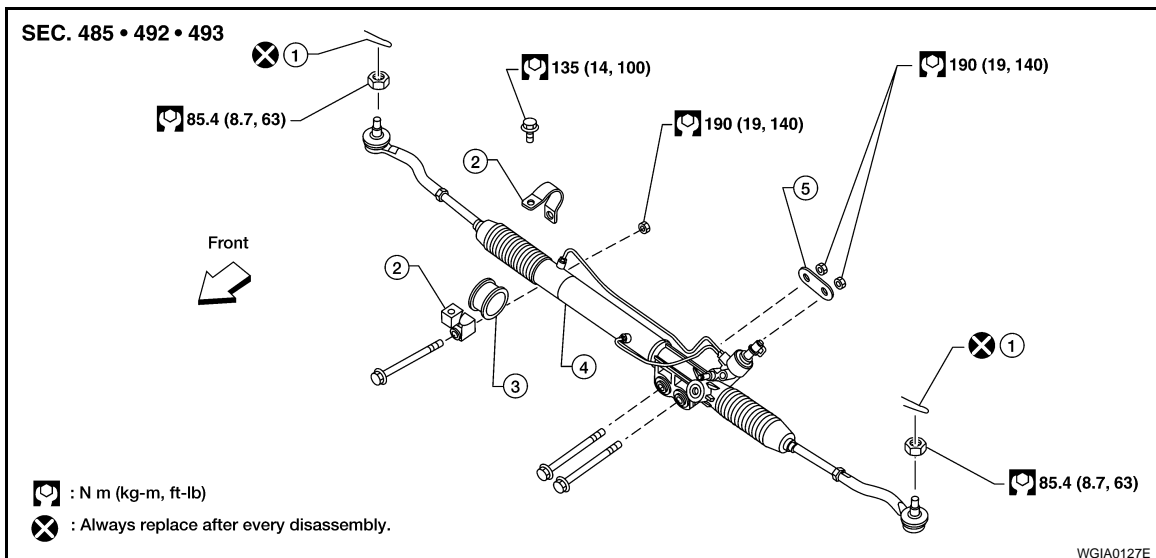

1. Cotter pin
2. Mounting bracket
3. Mounting insulator
4. Steering gear assembly
5. Washer

CAUTION:

Spiral cable may snap due to steering operation if steering column is separated from steering gear assembly. Therefore secure steering wheel to avoid turning.

REMOVAL

1. Turn wheels to the straight-ahead position.
2. Remove wheel and tire from vehicle using power tool.
3. Remove undercover using power tool.
4. On 4WD model, remove front final drive, then support drive shafts with wire. Refer to [DLN-178. "Removal and Installation"](#).
5. Make sure slit of lower joint fits with the projection on rear cover cap, while checking that mark on steering gear assembly aligns with mark on rear cover cap.

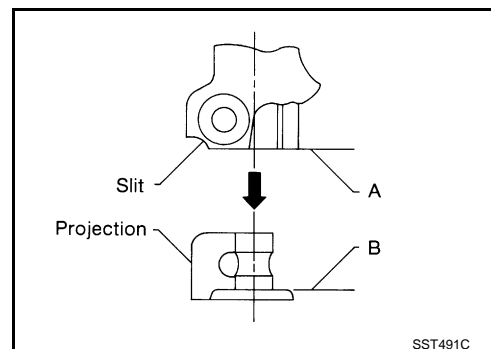

6. Remove cotter pin at steering outer socket and discard, then loosen nut.

POWER STEERING GEAR AND LINKAGE

< REMOVAL AND INSTALLATION >

7. Remove steering outer socket from steering knuckle using Tool. Be careful not to damage ball joint boot.

CAUTION:

Temporarily tighten nut to prevent damage to threads and to prevent Tool from coming off.

Tool number : HT72520000 (J-25730-A)

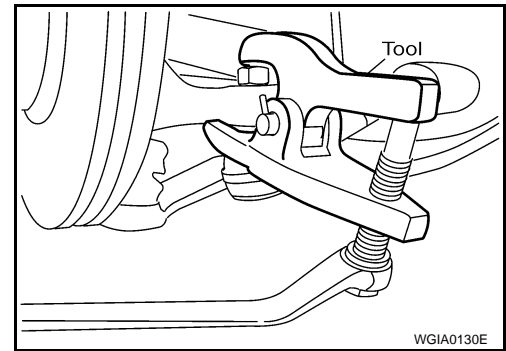

8. On 2WD model, remove stabilizer bar bolts and reposition stabilizer bar. Refer to [FSU-18, "Removal and Installation"](#).

9. Remove oil piping (high pressure side and low pressure side) from steering gear assembly, then drain fluid from piping.

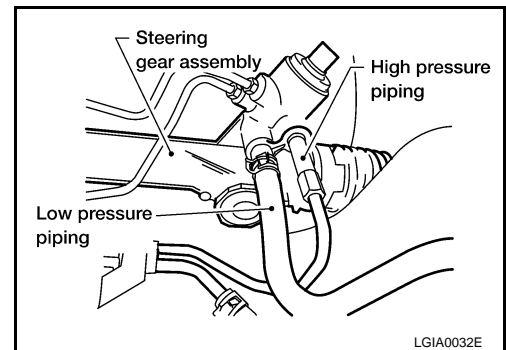

10. Remove lower joint bolt on lower shaft.

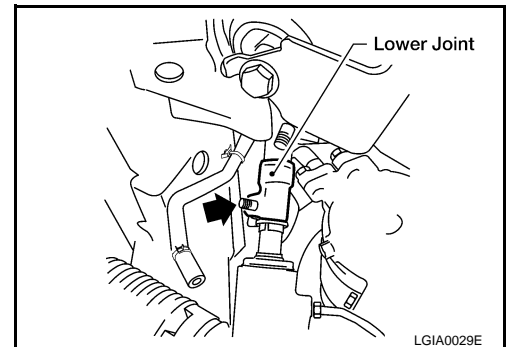

11. Remove bolts and nuts of steering gear assembly using power tool, and then remove steering gear assembly from vehicle.

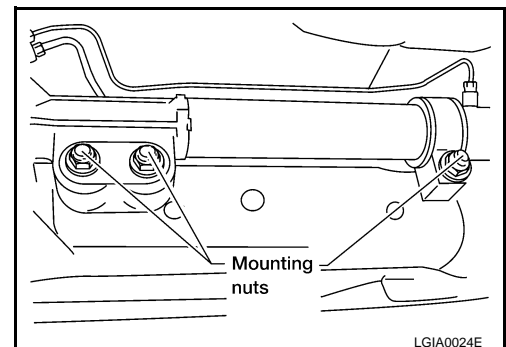

INSTALLATION

Installation is in the reverse order of removal.

- After removing/installing or replacing steering components, check wheel alignment. Refer to [FSU-5, "Front Wheel Alignment"](#).
- After adjusting wheel alignment, adjust neutral position of steering angle sensor. Refer to [BRC-150, "ADJUSTMENT OF STEERING ANGLE SENSOR NEUTRAL POSITION : Special Repair Requirement"](#).

POWER STEERING GEAR AND LINKAGE

< REMOVAL AND INSTALLATION >

- With steering wheel in straight ahead position, make sure slit of lower joint fits with the projection on rear cover cap, while checking that mark on steering gear assembly aligns with mark on rear cover cap

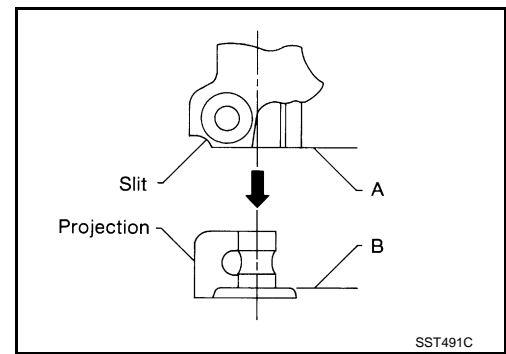

- After installation, bleed the air from the steering hydraulic system. Refer to [BR-16. "Bleeding Brake System"](#)

INSPECTION AFTER INSTALLATION

Check if steering wheel turns smoothly when it is turned several times fully to the left and right lock positions.

A
B
C
D
E
F

ST

H
I
J
K
L
M
N
O
P

POWER STEERING OIL PUMP

< REMOVAL AND INSTALLATION >

POWER STEERING OIL PUMP

Removal and Installation

INFOID:000000001349126

REMOVAL

1. Drain power steering fluid from reservoir tank.
2. Remove air duct assembly. Refer to [VTL-25, "Removal and Installation"](#).
3. Remove power steering reservoir tank.
4. Remove serpentine drive belt from auto tensioner and power steering pump. Refer to [EM-12, "Removal and Installation"](#).
5. Disconnect pressure sensor electrical connector.
6. Remove high pressure and low pressure piping from power steering oil pump. Refer to [ST-21](#).
7. Remove bolts, then remove power steering pump.

INSTALLATION

Installation is in the reverse order of removal. Refer to [ST-21](#) for tightening torque.

- After installation, bleed air. Refer to [BR-16, "Bleeding Brake System"](#).

NOTE:

Belt tension is automatic and requires no adjustment.

HYDRAULIC LINE

< REMOVAL AND INSTALLATION >

HYDRAULIC LINE

Removal and Installation

INFOID:000000001349128

Refer to the following illustration for hydraulic line removal.

SEC. 490 • 492 • 497

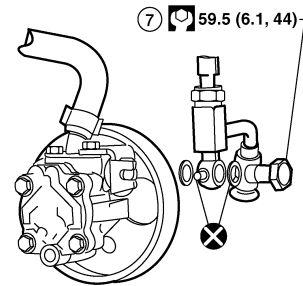
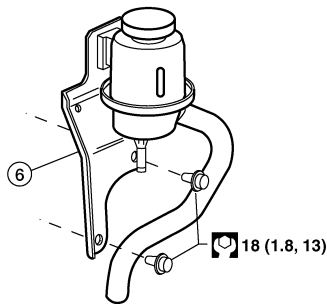
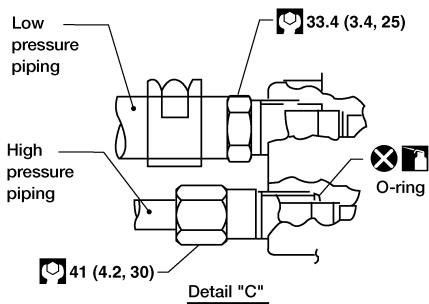
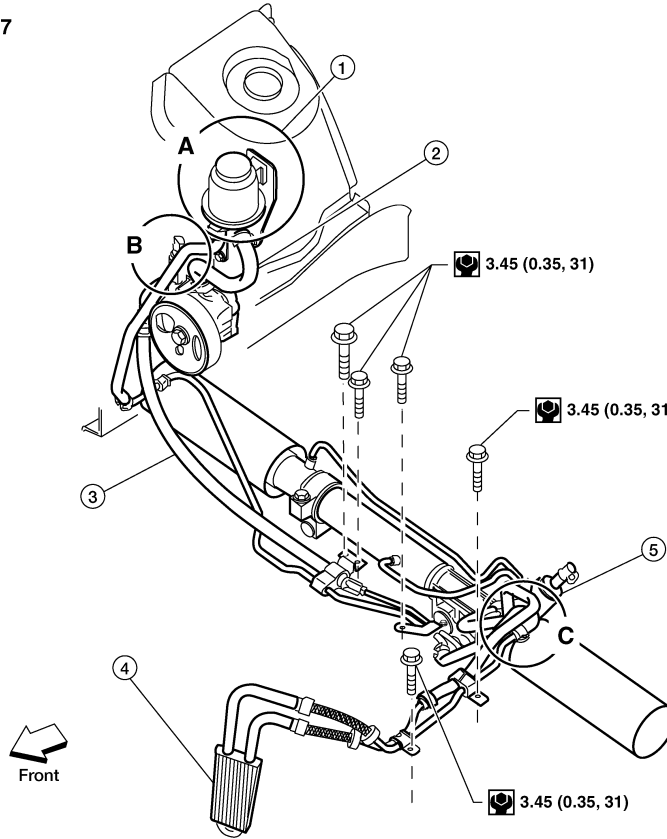

- : Lubricate with engine oil
- : N-m (kg-m, ft-lb)
- : N-m (kg-m, in-lb)
- : Always replace after every disassembly.

WGIA0111E

- | | | |
|-------------------|---------------------------|---------------------------|
| 1. Reservoir tank | 2. Suction hose | 3. High pressure hose |
| 4. Oil cooler | 5. Steering gear assembly | 6. Reservoir tank bracket |
| 7. Eye bolt | | |

Installation is in the reverse order of removal.

HYDRAULIC LINE

< REMOVAL AND INSTALLATION >

- Confirm mating marks are aligned with hose and clamp, then correct if needed.

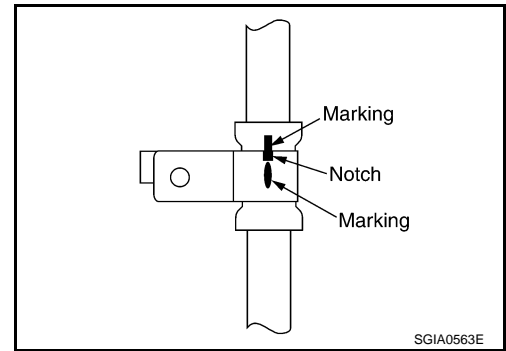

- To install eye joint, align projection of eye joint with notch of power steering pump, and attach eye joint to power steering pump properly. Tighten eye bolt by hand fully, then torque to specification.

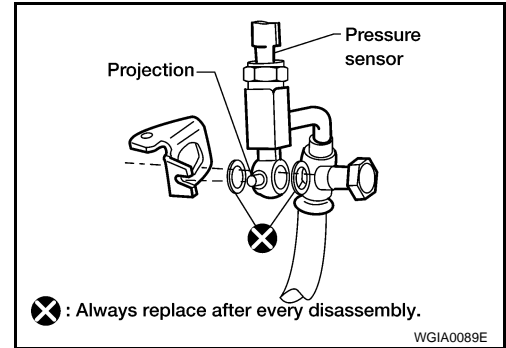

STEERING COLUMN

< DISASSEMBLY AND ASSEMBLY >

DISASSEMBLY AND ASSEMBLY

STEERING COLUMN

Disassembly and Assembly

INFOID:000000001349130

Column Shift Model

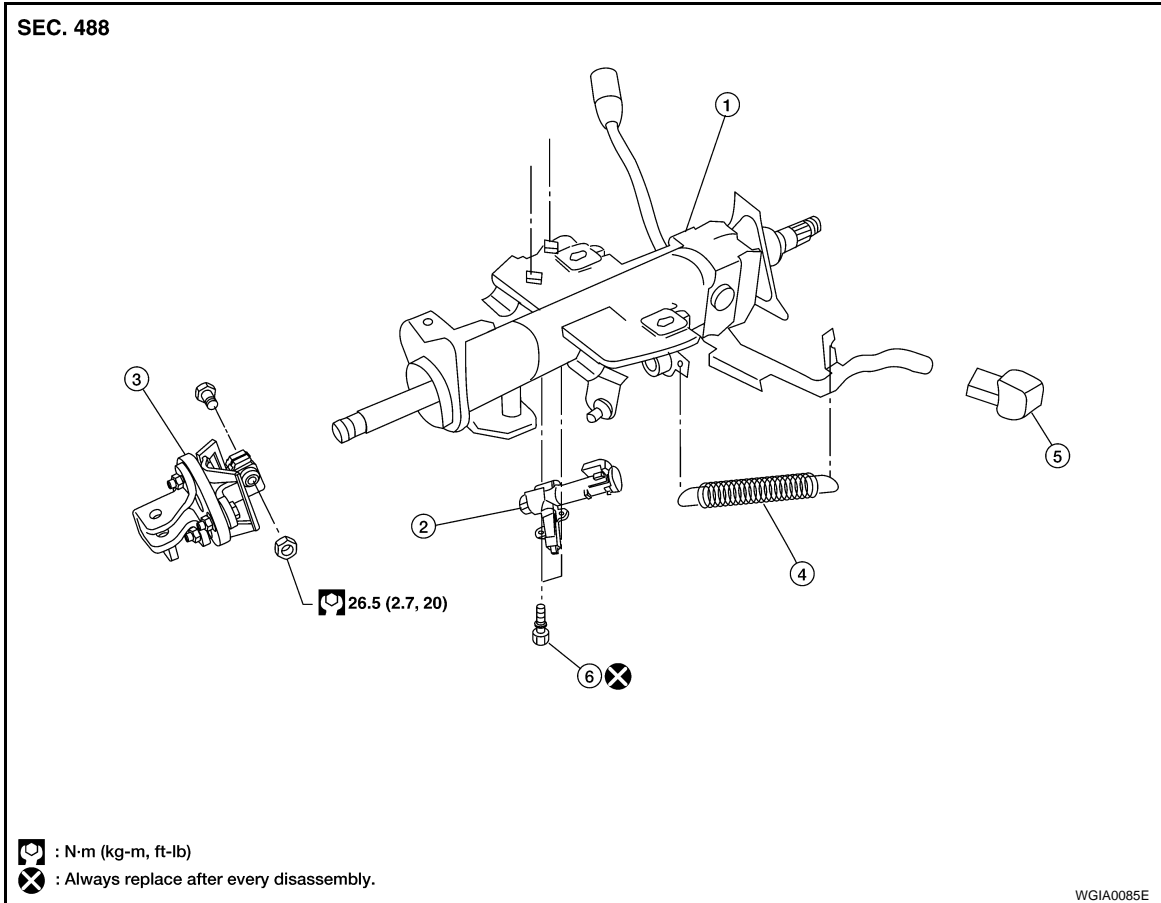

- | | | |
|-----------------------------|--------------------|---------------------|
| 1. Steering column assembly | 2. Ignition switch | 3. Upper joint |
| 4. Spring | 5. Tilt lever knob | 6. Self-shear screw |

STEERING COLUMN

< DISASSEMBLY AND ASSEMBLY >

Floor Shift Model

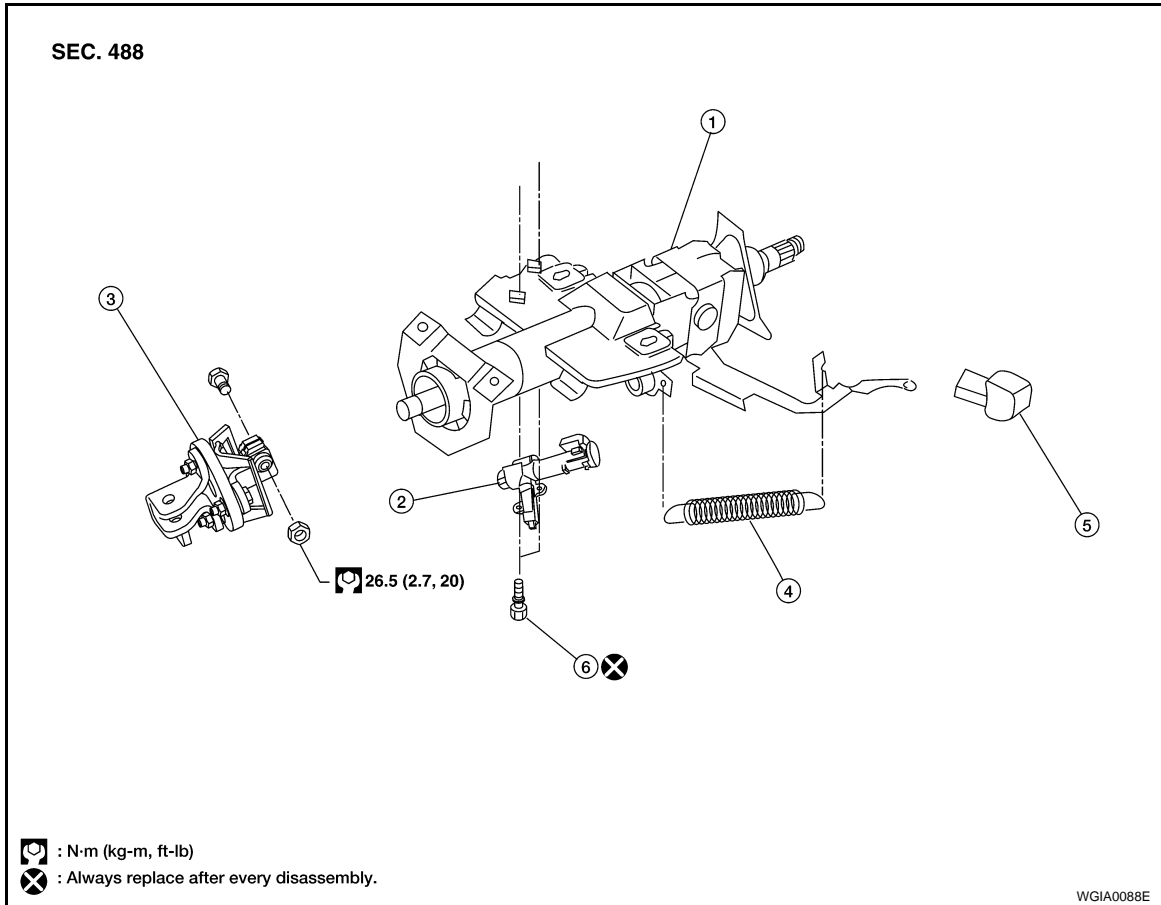

- | | | |
|-----------------------------|--------------------|---------------------|
| 1. Steering column assembly | 2. Ignition switch | 3. Upper joint |
| 4. Spring | 5. Tilt lever knob | 6. Self-shear screw |

DISASSEMBLY

1. Remove spring from steering column assembly and tilt lever.
2. Remove upper joint bolt, then remove upper joint from steering column assembly.
3. Remove ignition switch tamper resistant self-shear type screws with a drill or other appropriate tool.

ASSEMBLY

- Assembly is in the reverse order of disassembly.
- Install new tamper resistant self-shear type screws.

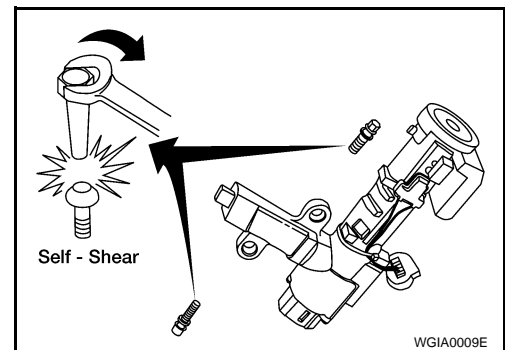

INSPECTION AFTER ASSEMBLY

When the steering wheel does not turn smoothly, check the steering column as follows:

1. Check the column bearings for damage or unevenness. Lubricate with recommended multi-purpose grease. Replace the steering column as an assembly, if necessary.
2. Check the column tube for deformation or breakage. Replace the steering column as an assembly, if necessary.

STEERING COLUMN

< DISASSEMBLY AND ASSEMBLY >

3.

If the vehicle has been involved in a collision, or if noise and rattles are heard during a turn, check the length (L) of the column. If out of specification, replace the steering column as an assembly.

Steering column length (L) : 610 mm (24.02 in)

4. Check for proper lubrication, apply grease as necessary.
5. Check for wear around the seal edges, replace as necessary.
6. Check for corrosion or pitting around the seal sliding area.
7. Replace the seal and shaft in case of seal edge wear or damage.

8.

After installing the steering column, check the tilt mechanism for proper operation.

**Tilt mechanism range : 3° per notch at 5 steps
(Manual tilt)**

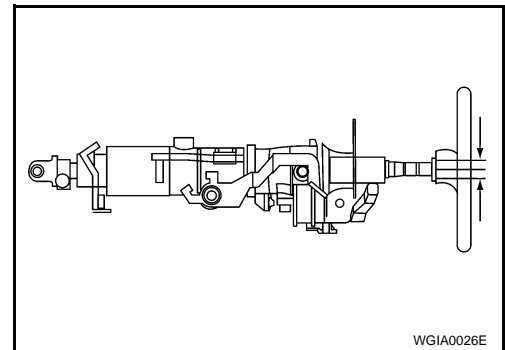
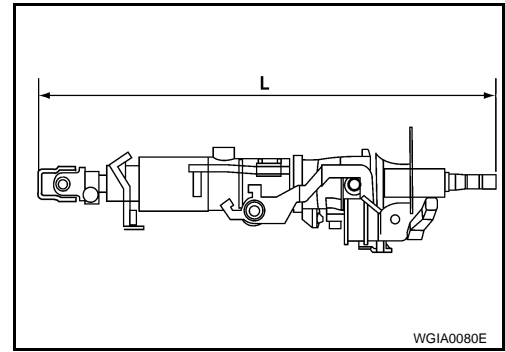

CAUTION:

- Do not exert any load or impact in the axial direction immediately before or after column removal.
- After installation, check for smooth steering wheel rotation, without any catches or noise.
- Replace the column if it is depleted of grease, worn, damaged, or if any scratches or coating separation is present on the shaft seal area.
- The lower nut on the upper joint may not be reused.
- During lower joint detachment, insert a tool into the yoke groove to prevent gouging damage.

A
B
C
D
E
F
ST
H
I
J
K
L
M
N
O
P

POWER STEERING GEAR AND LINKAGE

< DISASSEMBLY AND ASSEMBLY >

POWER STEERING GEAR AND LINKAGE

Disassembly and Assembly

INFOID:000000001349132

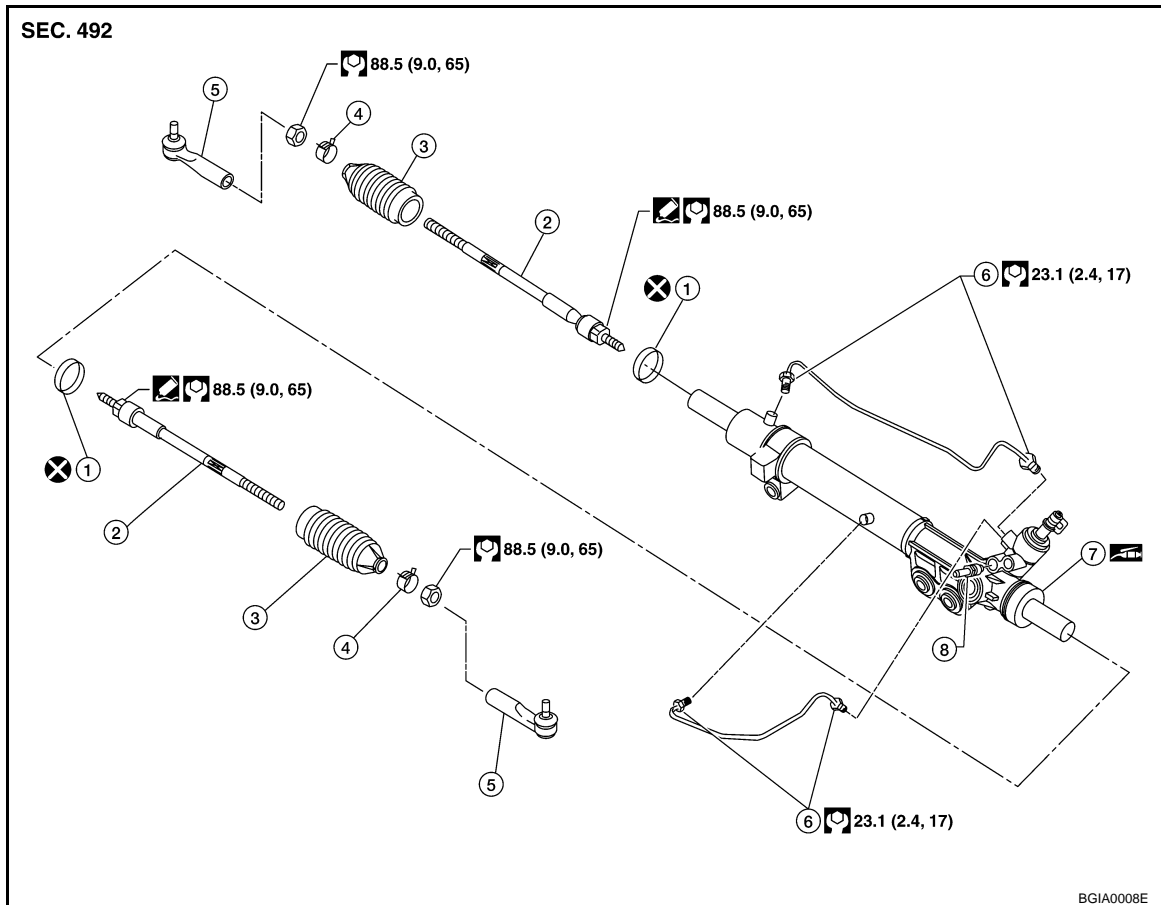

- | | | |
|--------------------------|-----------------|-------------------|
| 1. Boot clamp | 2. Inner socket | 3. Boot |
| 4. Boot clamp | 5. Outer socket | 6. Cylinder tubes |
| 7. Gear housing assembly | 8. Connector | |

CAUTION:

- Secure steering gear assembly with a vise, using copper plates or something similar to prevent it from being damaged. Do not grip cylinder with a vise.
- Before performing disassembly, clean steering gear assembly with kerosene. Be careful not to bring any kerosene into contact with the discharge and return port connectors.

DISASSEMBLY

1. Remove cylinder tubes from gear housing assembly.
2. Loosen lock nuts of outer sockets, and remove outer sockets.
3. Remove boot clamps of the small diameter side and the large diameter side, then remove boot.

CAUTION:

When removing boots, be careful not to damage inner socket and gear housing assembly. If they are damaged, change them to avoid oil leaks.

4. Remove inner sockets.

INSPECTION AFTER DISASSEMBLY

Boot

Check boot for tears, cracks and deformation. Replace if necessary.

POWER STEERING GEAR AND LINKAGE

< DISASSEMBLY AND ASSEMBLY >

Gear Housing Assembly

Check gear housing assembly for dents, cracks or damage. Replace as an assembly if necessary.

Outer Socket and Inner Socket

SWING TORQUE

- Measure the swing torque, using Tool. When ball stud and inner socket start moving the measured value must be within the specification. If the reading is outside the specification, replace the socket.

Tool number : — (J-44372)

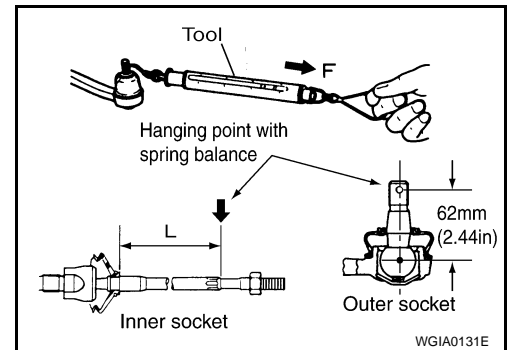

Item	Outer socket	Inner socket
Measuring point	Cotter pin hole of stud	Shown as L: 83.2 mm (3.276 in)
Swing torque	0.3 – 2.9 N·m (0.03 – 0.29 kg·m, 3 – 25 in·lb)	1.0 – 7.8 N·m (0.11 – 0.79 kg·m, 9 – 69 in·lb)
Measuring value (F)	4.84 – 46.7 N (0.50 – 4.7 kg·f, 4 - 34 lb·f)	12.1 – 93.7 N (1.3 – 9.5 kg, 9 – 69 lb)

ROTATING TORQUE

- Measure the rotating torque, using Tool. If the value is outside the specification, replace the outer sockets.

Tool number : ST3127S000 (J-25765-A)

Rotating torque : 0.3 – 2.9 N·m (0.03 – 0.29 kg·m, 3 – 25 in·lb)

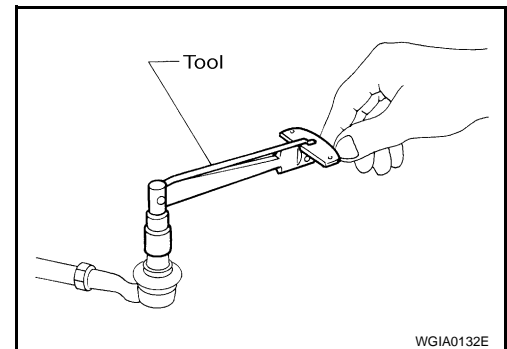

AXIAL END PLAY

- Apply a load of 490 N (50 kg·f, 110 lb·f) to the ball stud axially. Use a dial gauge to measure the amount of the movement that the stud makes. If the value is outside the specification, replace the sockets.

Outer socket : 0.5 mm (0.020 in) or less

Inner socket : 0.2 mm (0.008 in) or less

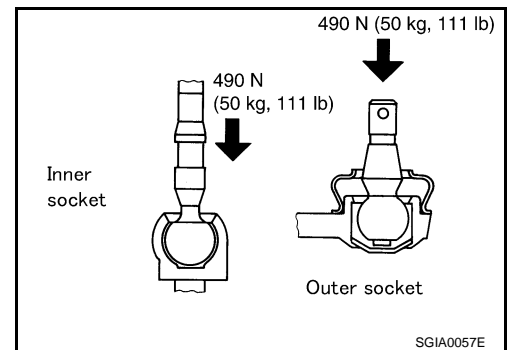

ASSEMBLY

1. Install the inner sockets.

POWER STEERING GEAR AND LINKAGE

< DISASSEMBLY AND ASSEMBLY >

2. Install the large-diameter side of the boots to the gear housing assembly.
3. Install the small-diameter side of the boots to the groove of the inner sockets.

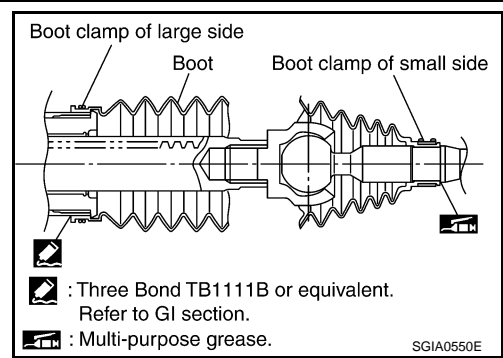

4. Install the boot clamps to the boots, as shown.
CAUTION:
Do not reuse the large-diameter boot clamps.

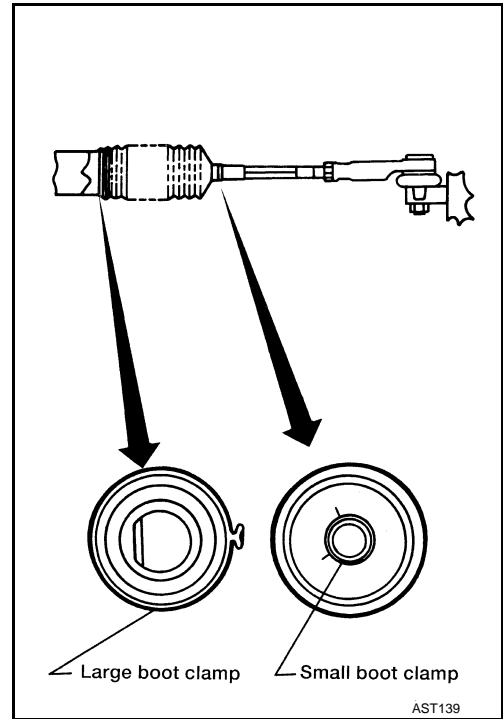

5. Crimp the large-diameter boot clamps, using Tool.

Tool number : KV40107300 (—)

6. Install the cylinder tubes to the gear housing assembly.
7. Install the lock nuts and outer sockets to the inner sockets.

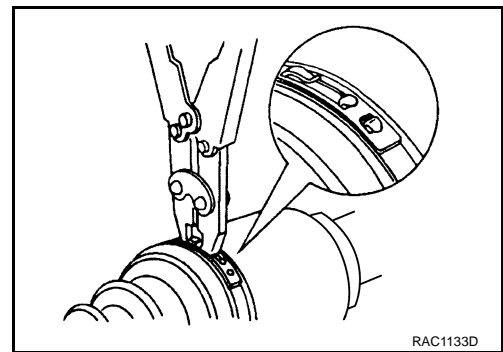

8. Thread the outer sockets onto the inner sockets to the specified length "L", then tighten the lock nuts to the specification. Refer to "Disassembly and Assembly" . Reconfirm that the tie-rod length "L" is within specification.

Maximum inner socket length "L" : 115.2 mm (4.54 in)

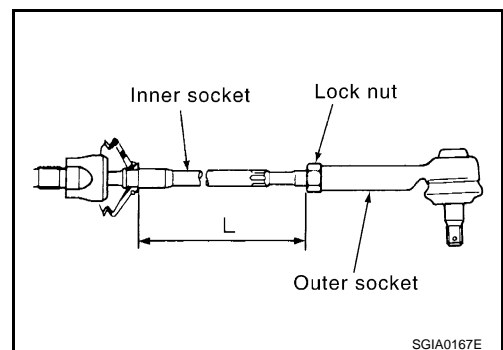

POWER STEERING OIL PUMP

< DISASSEMBLY AND ASSEMBLY >

POWER STEERING OIL PUMP

Disassembly and Assembly

INFOID:000000001349135

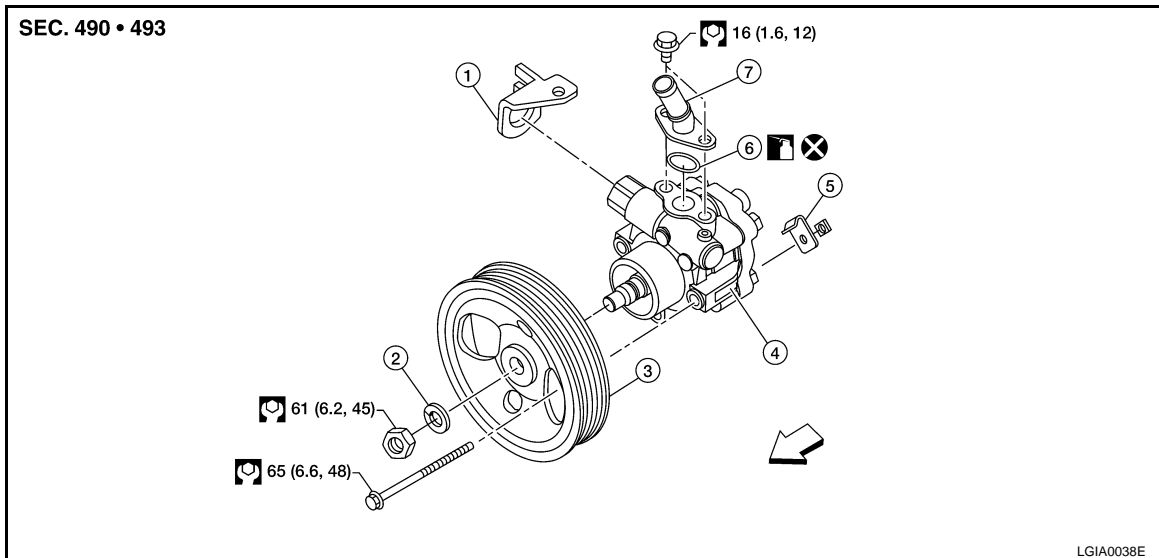

- | | | |
|------------------------|-------------------------------|-----------|
| 1. Bracket | 2. Spring washer | 3. Pulley |
| 4. Power steering pump | 5. High pressure hose bracket | 6. O-ring |
| 7. Suction pipe | ← Front | |

INSPECTION BEFORE DISASSEMBLY

Disassemble the power steering oil pump only if the following items are found.

- Deformed or damaged pulley, bracket, connector or suction pipe.
- Oil leakage from the suction pipe or connector.

DISASSEMBLY

NOTE:

Mount the power steering oil pump in a vise as needed.

1. Remove the connector bolt, connector and copper washers.

CAUTION:

Do not reuse the copper washers.

2. Remove the suction pipe and O-ring.

CAUTION:

Do not reuse the O-ring.

3. Remove the pulley nut and pulley.
4. Remove the bracket bolts and bracket.

INSPECTION AFTER DISASSEMBLY

Body Assembly Inspection

Check the power steering oil pump body assembly for damage. If any damage is found, replace with a new power steering oil pump assembly.

ASSEMBLY

Assembly is in the reverse order of disassembly.

CAUTION:

- Do not reuse the copper gaskets
- Do not reuse the O-ring. Apply a coat of Genuine Nissan PSF or equivalent to the O-ring.

SERVICE DATA AND SPECIFICATIONS (SDS)

< SERVICE DATA AND SPECIFICATIONS (SDS)

SERVICE DATA AND SPECIFICATIONS (SDS)

SERVICE DATA AND SPECIFICATIONS (SDS)

Steering Wheel

INFOID:000000001349137

End play of the axial direction for steering wheel	0 mm (0 in)
Steering wheel play on the outer circumference	0 – 35 mm (0 – 1.38 in)
Steering wheel turning force	39 N (4 kg-f, 9 lb-f) or less

Steering Column

INFOID:000000001349138

Inspection After Assembly

Unit: mm (in)

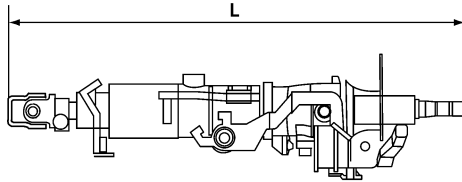

WGIA0080E

Steering column length "L"	610 (24.02)
----------------------------	-------------

Inspection After Removal

Unit: mm (in)

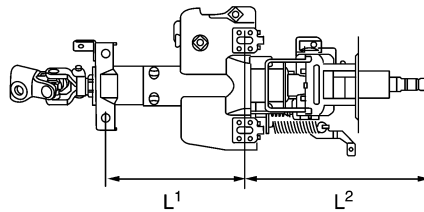

SGIA0475E

Steering column length "L ¹ "	158 (6.22)
Steering column length "L ² "	262 (10.31)

SERVICE DATA AND SPECIFICATIONS (SDS)

< SERVICE DATA AND SPECIFICATIONS (SDS)

Inspection After Installation

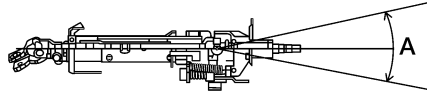

WGIA0083E

Range "A"	61.3 mm (2.41 in)
Tilt mechanism range (Manual tilt)	3° per notch at 5 steps

Steering Outer Socket and Inner Socket

INFOID:000000001349139

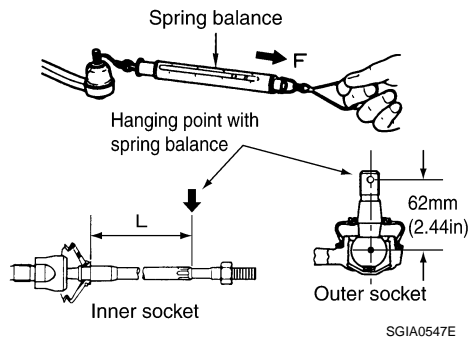

SGIA0547E

Tie-rod ball joint outer socket	Swinging torque (F)	0.3 – 2.9 N·m (0.03 – 0.29 kg·m, 3 – 25 in-lb)
	Measurement on spring balance • Measuring point: cotter pin hole of stud	4.84 – 46.7 N (0.50 – 4.7 kg-f, 4 – 34 lb-f)
	Rotating torque	0.3 – 2.9 N·m (0.03 – 0.29 kg·m, 3 – 25 in-lb)
	Axial end play	0.5 mm (0.020 in) or less
Tie-rod ball joint inner socket	Swinging torque	1.0 – 7.8 N·m (0.11 – 0.79 kg·m, 9 – 69 in-lb)
	Measurement on spring balance • Measuring point: L mark see above, L=83.2 mm (3.276 in).	12.1 – 93.7 N (1.3 – 9.5 kg-f, 9 – 69 lb-f)
	Axial end play	0.2 mm (0.08 in) or less

Unit: mm (in)

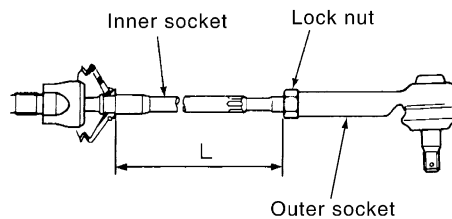

SGIA0167E

Inner socket length "L"	115.2 (4.54)
-------------------------	--------------

SERVICE DATA AND SPECIFICATIONS (SDS)

< SERVICE DATA AND SPECIFICATIONS (SDS)

Steering Gear

INFOID:000000001349140

Steering gear model	PR26AM
Rack neutral position, dimension "L" (rack stroke)	85.5 mm (3.36 in)

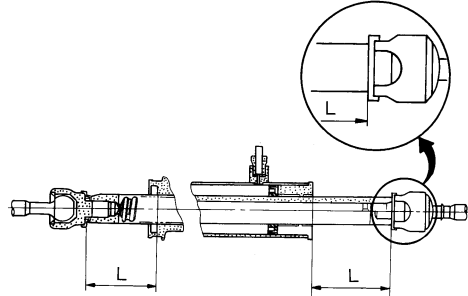

STC0034D

Rack sliding force	At the neutral point: Range within ± 11.5 mm (± 0.453 in) from the neutral position (in power ON)	Area average value	147 – 211 N (14.99 – 21.52 kg-f, 33.1 – 47.52 lb-f)
		Allowable variation	98 N (10 kg-f, 22 lb-f) or less
	Whole area (in power OFF)	Peak value	294 N (30.0 kg-f, 66 lb-f) or less
		Allowable variation	147 N (16 kg-f, 35 lb-f) or less

Oil Pump

INFOID:000000001349141

Relief oil pressure	9.0 – 9.8 mPa (91.77 – 99.93 kg/cm ² , 1305.34 – 1421.37 psi)
---------------------	--------------------------------------------------------------------------

Steering Fluid

INFOID:000000001349142

Fluid capacity	Approx. 1.0 ℓ (1-1/8 US qt, 7/8 Imp qt)
----------------	-----------------------------------------