

# MWI

## SECTION

### METER, WARNING LAMP & INDICATOR

A  
B  
C

## CONTENTS

<b>BASIC INSPECTION</b> .....	<b>FUEL GAUGE : Component Description</b> .....	F
<b>DIAGNOSIS AND REPAIR WORKFLOW</b> .....	<b>ENGINE OIL PRESSURE GAUGE</b> .....	G
Work Flow .....	ENGINE OIL PRESSURE GAUGE : System Dia-gram .....	H
<b>FUNCTION DIAGNOSIS</b> .....	ENGINE OIL PRESSURE GAUGE : System De-scription .....	I
<b>METER SYSTEM</b> .....	ENGINE OIL PRESSURE GAUGE : Component Parts Location .....	J
<b>METER SYSTEM</b> .....	ENGINE OIL PRESSURE GAUGE : Component Description .....	K
METER SYSTEM : System Diagram .....	<b>A/T OIL TEMPERATURE GAUGE</b> .....	L
METER SYSTEM : System Description .....	A/T OIL TEMPERATURE GAUGE : System Dia-gram .....	M
METER SYSTEM : Arrangement of Combination Meter .....	A/T OIL TEMPERATURE GAUGE : System De-scription .....	MWI
METER SYSTEM : Component Parts Location .....	A/T OIL TEMPERATURE GAUGE : Component Parts Location .....	O
METER SYSTEM : Component Description .....	A/T OIL TEMPERATURE GAUGE : Component Description .....	P
<b>SPEEDOMETER</b> .....	<b>VOLTAGE GAUGE</b> .....	
SPEEDOMETER : System Diagram .....	VOLTAGE GAUGE : System Diagram .....	
SPEEDOMETER : System Description .....	VOLTAGE GAUGE : System Description .....	
SPEEDOMETER : Component Parts Location .....	VOLTAGE GAUGE : Component Parts Location .....	
SPEEDOMETER : Component Description .....	VOLTAGE GAUGE : Component Description .....	
<b>TACHOMETER</b> .....	<b>ODO/TRIP METER</b> .....	
TACHOMETER : System Diagram .....	ODO/TRIP METER : System Diagram .....	
TACHOMETER : System Description .....	ODO/TRIP METER : System Description .....	
TACHOMETER : Component Parts Location .....	ODO/TRIP METER : Component Parts Location .....	
TACHOMETER : Component Description .....	ODO/TRIP METER : Component Description .....	
<b>ENGINE COOLANT TEMPERATURE GAUGE</b> .....	<b>SHIFT POSITION INDICATOR</b> .....	
ENGINE COOLANT TEMPERATURE GAUGE : System Diagram .....	SHIFT POSITION INDICATOR : System Diagram .....	
ENGINE COOLANT TEMPERATURE GAUGE : System Description .....	SHIFT POSITION INDICATOR : System Description .....	
ENGINE COOLANT TEMPERATURE GAUGE : Component Parts Location .....	SHIFT POSITION INDICATOR : Component Parts Location .....	
ENGINE COOLANT TEMPERATURE GAUGE : Component Description .....	SHIFT POSITION INDICATOR : Component Description .....	
<b>FUEL GAUGE</b> .....		
FUEL GAUGE : System Diagram .....		
FUEL GAUGE : System Description .....		
FUEL GAUGE : Component Parts Location .....		

<b>WARNING LAMPS/INDICATOR LAMPS</b> .....	<b>20</b>	<b>PARKING BRAKE SWITCH SIGNAL CIRCUIT</b> .....	<b>40</b>
WARNING LAMPS/INDICATOR LAMPS : System Diagram .....	21	Description .....	40
WARNING LAMPS/INDICATOR LAMPS : System Description .....	21	Component Function Check .....	40
WARNING LAMPS/INDICATOR LAMPS : Component Parts Location .....	21	Diagnosis Procedure .....	40
WARNING LAMPS/INDICATOR LAMPS : Component Description .....	22	Component Inspection .....	40
<b>INFORMATION DISPLAY</b> .....	<b>22</b>	<b>WASHER LEVEL SWITCH SIGNAL CIRCUIT..</b>	<b>41</b>
INFORMATION DISPLAY : System Diagram .....	22	Description .....	41
INFORMATION DISPLAY : System Description ...	22	Diagnosis Procedure .....	41
INFORMATION DISPLAY : Component Parts Location .....	23	Component Inspection .....	41
INFORMATION DISPLAY : Component Description .....	24	<b>COMPASS</b> .....	<b>42</b>
<b>COMPASS</b> .....	<b>25</b>	Wiring Diagram - With HomeLink® Universal Transceiver - .....	42
Description .....	25	Wiring Diagram - Without HomeLink® Universal Transceiver - .....	44
<b>DIAGNOSIS SYSTEM (METER)</b> .....	<b>27</b>	<b>ECU DIAGNOSIS</b> .....	<b>46</b>
Diagnosis Description .....	27	<b>COMBINATION METER</b> .....	<b>46</b>
CONSULT-III Function (METER/M&A) .....	28	Reference Value .....	46
<b>COMPONENT DIAGNOSIS</b> .....	<b>31</b>	Wiring Diagram .....	48
<b>DTC U1000 CAN COMMUNICATION</b> .....	<b>31</b>	Fail Safe .....	64
DTC Logic .....	31	DTC Index .....	65
Diagnosis Procedure .....	31	<b>BCM (BODY CONTROL MODULE)</b> .....	<b>67</b>
<b>DTC B2205 VEHICLE SPEED CIRCUIT</b> .....	<b>32</b>	Reference Value .....	67
Description .....	32	Terminal Layout .....	69
DTC Logic .....	32	Physical Values .....	69
Diagnosis Procedure .....	32	Wiring Diagram .....	75
<b>POWER SUPPLY AND GROUND CIRCUIT</b> ....	<b>33</b>	Fail Safe .....	79
<b>COMBINATION METER</b> .....	<b>33</b>	DTC Inspection Priority Chart .....	80
COMBINATION METER : Diagnosis Procedure ...	33	DTC Index .....	80
<b>BCM (BODY CONTROL MODULE)</b> .....	<b>33</b>	<b>IPDM E/R (INTELLIGENT POWER DISTRIBUTION MODULE ENGINE ROOM)</b> .....	<b>82</b>
BCM (BODY CONTROL MODULE) : Diagnosis Procedure .....	34	Reference Value .....	82
<b>IPDM E/R (INTELLIGENT POWER DISTRIBUTION MODULE ENGINE ROOM)</b> .....	<b>34</b>	Terminal Layout .....	84
IPDM E/R (INTELLIGENT POWER DISTRIBUTION MODULE ENGINE ROOM) : Diagnosis Procedure .....	34	Physical Values .....	84
<b>FUEL LEVEL SENSOR SIGNAL CIRCUIT</b> .....	<b>36</b>	Wiring Diagram .....	88
Description .....	36	Fail Safe .....	91
Component Function Check .....	36	DTC Index .....	93
Diagnosis Procedure .....	36	<b>SYMPTOM DIAGNOSIS</b> .....	<b>94</b>
Component Inspection .....	37	<b>THE FUEL GAUGE POINTER DOES NOT MOVE</b> .....	<b>94</b>
<b>OIL PRESSURE SWITCH SIGNAL CIRCUIT</b> ...	<b>39</b>	Description .....	94
Description .....	39	Diagnosis Procedure .....	94
Component Function Check .....	39	<b>THE FUEL GAUGE POINTER DOES NOT MOVE TO "F" WHEN REFUELING</b> .....	<b>95</b>
Diagnosis Procedure .....	39	Description .....	95
Component Inspection .....	39	Diagnosis Procedure .....	95
		<b>THE OIL PRESSURE WARNING LAMP DOES NOT TURN ON</b> .....	<b>96</b>
		Description .....	96
		Diagnosis Procedure .....	96



# DIAGNOSIS AND REPAIR WORKFLOW

< BASIC INSPECTION >

## BASIC INSPECTION

### DIAGNOSIS AND REPAIR WORKFLOW

Work Flow

INFOID:000000003790386

DETAILED FLOW

#### 1.CONFIRM SYMPTOM

Confirm symptom or customer complaint.

>> GO TO 2

#### 2.CHECK SELF-DIAGNOSIS OPERATION OF COMBINATION METER

Perform self-diagnosis of combination meter. Refer to [MWI-27. "Diagnosis Description"](#).

Does self-diagnosis mode operate?

YES >> GO TO 3

NO >> Check power supply and ground circuit of combination meter. Refer to [MWI-33. "COMBINATION METER : Diagnosis Procedure"](#). Then, GO TO 4

#### 3.CHECK COMBINATION METER (CONSULT-III)

Select "METER/M&A" on CONSULT-III and perform "SELF-DIAGNOSIS" of combination meter. Refer to [MWI-28. "CONSULT-III Function \(METER/M&A\)"](#).

Self-diagnostic results content

No malfunction detected>>Repair or replace the cause of symptom. Then, GO TO 4

Malfunction detected>>Refer to [MWI-65. "DTC Index"](#). Then, GO TO 4

#### 4.CONFIRM OPERATION

Does the combination meter operate normally?

YES or NO

YES >> Inspection End.

NO >> GO TO 1

# METER SYSTEM

< FUNCTION DIAGNOSIS >

## FUNCTION DIAGNOSIS

METER SYSTEM

METER SYSTEM

METER SYSTEM : System Diagram

INFOID:000000003790387

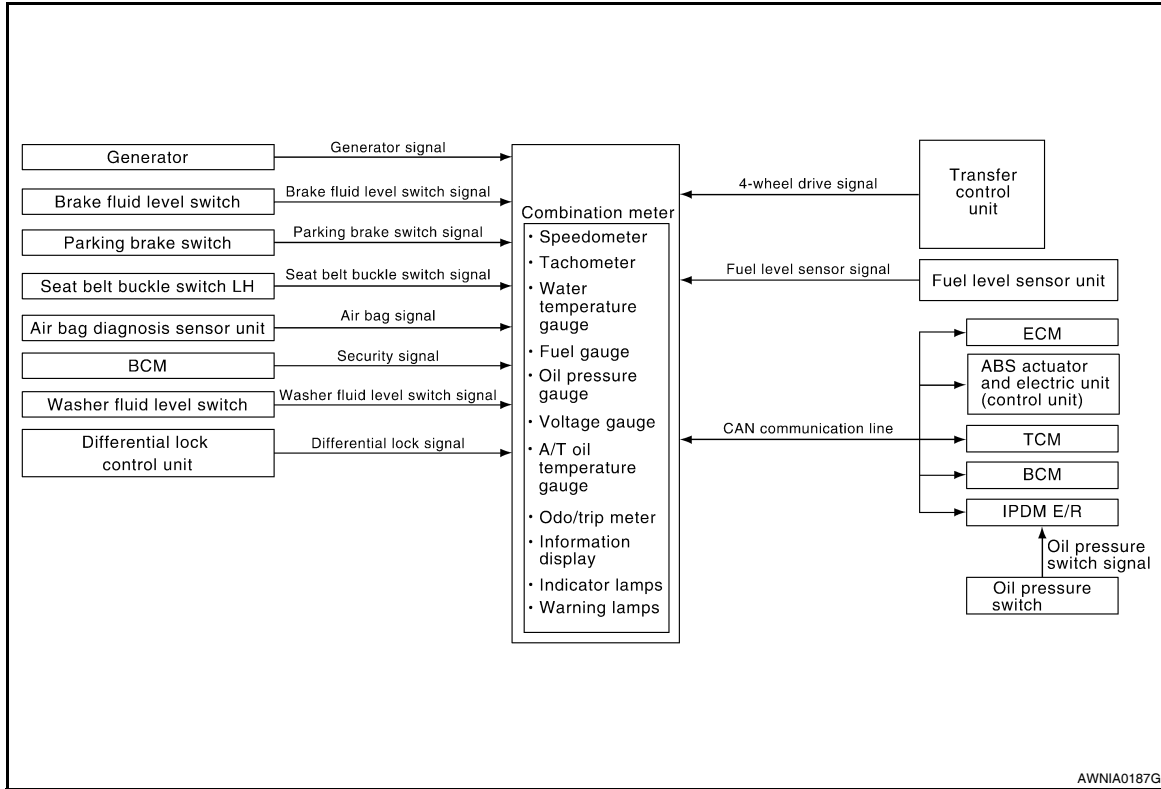

METER SYSTEM : System Description

INFOID:000000003790388

### COMBINATION METER

- Speedometer, odo/trip meter, tachometer, fuel gauge, engine coolant temperature gauge, engine oil pressure gauge (if equipped), voltage gauge (if equipped), A/T oil temperature gauge (if equipped) and information display are controlled by the unified meter control unit, which is built into the combination meter.
- Warning and indicator lamps are controlled by the unified meter control unit and by components connected directly to the combination meter.
- Digital meter is adopted for odo/trip meter.\*  
\*The record of the odometer is kept even if the battery cable is disconnected. The record of the trip meter is erased when the battery cable is disconnected.
- Odo/trip meter segments can be checked in diagnosis mode.
- Meter/gauge can be checked in diagnosis mode.

A  
B  
C  
D  
E  
F  
G  
H  
I  
J  
K  
L  
M  
MWI  
O  
P

# METER SYSTEM

< FUNCTION DIAGNOSIS >

## METER SYSTEM : Arrangement of Combination Meter

INFOID:000000003790389

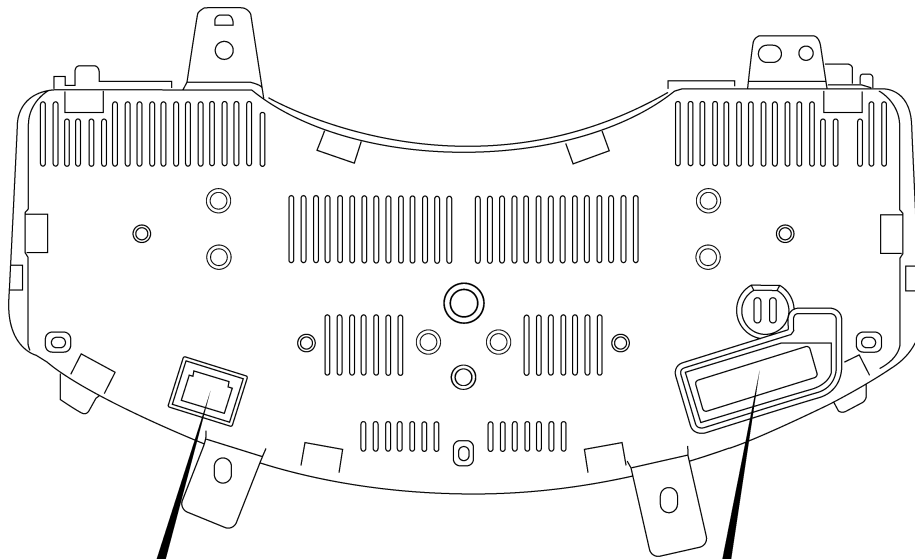
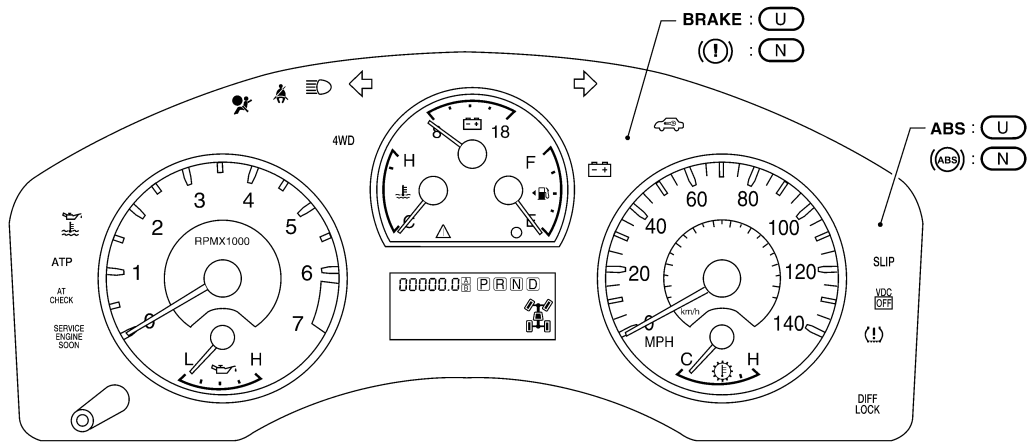

(N) : CANADA  
(U) : USA

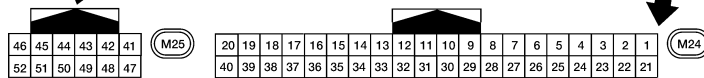

AWNIA0188GB

# METER SYSTEM

< FUNCTION DIAGNOSIS >

## METER SYSTEM : Component Parts Location

INFOID:000000003790390

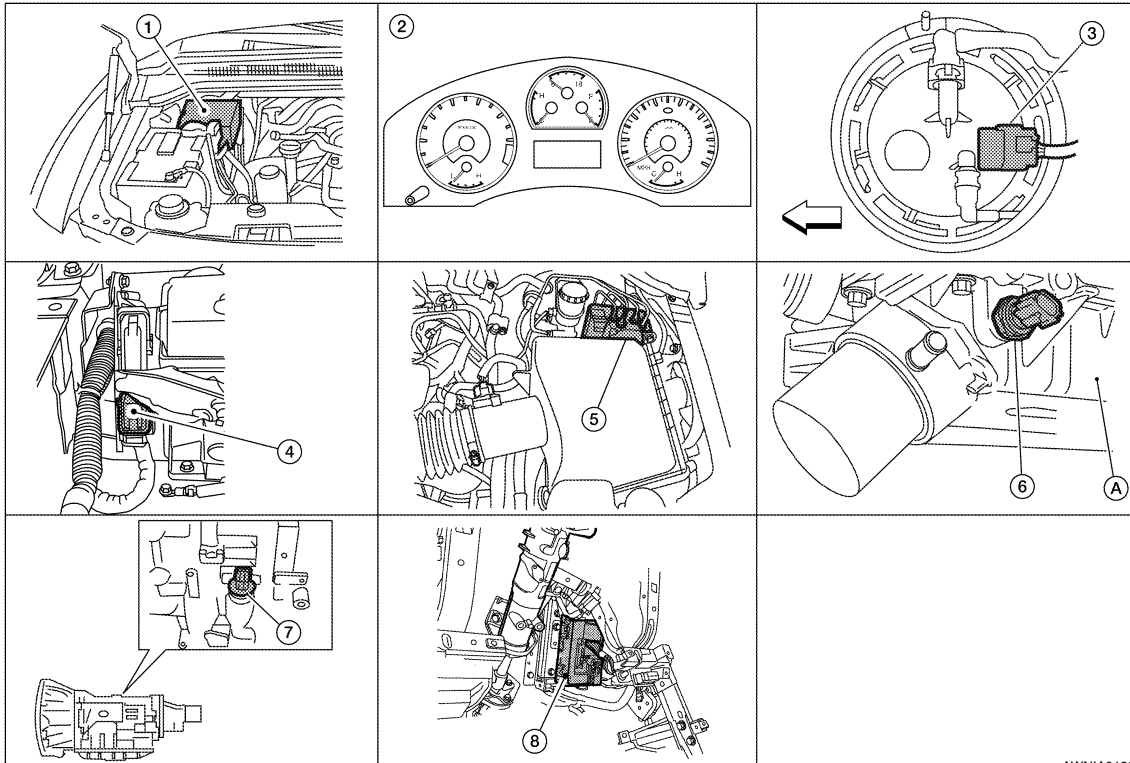

AWNIA0190ZZ

- |   |   |   |
|---|---|---|
| 1. IPDM E/R E122, E124  | 2. Combination meter M24, M25   | 3. Fuel level sensor unit and fuel pump<br>(view with fuel tank removed)<br>C7 (with Flexible Fuel)<br>C5 (without Flexible Fuel)<br>←: Front |
| 4. ECM E16 (view with battery removed)                              | 5. ABS actuator and electric unit (control unit)<br>E126 (with VDC)<br>E125 (without VDC) | 6. Oil pressure switch F4<br>A: Oil pan (upper)   |
| 7. A/T assembly<br>F9 (with floor shift)<br>F17 (with column shift) | 8. BCM M18, M19 (view with instrument lower panel LH removed)                             |   |

## METER SYSTEM : Component Description

INFOID:000000003790391

Unit	Description
Combination meter	<p>Controls the following with the signals received from each unit via CAN communication and the signals from switches and sensors.</p> <ul style="list-style-type: none"> <li>• Speedometer</li> <li>• Engine coolant temperature gauge</li> <li>• Engine oil pressure gauge (if equipped)</li> <li>• Voltage gauge (if equipped)</li> <li>• Warning lamps</li> <li>• Information display</li> <li>• Tachometer</li> <li>• Fuel gauge</li> <li>• A/T oil temperature gauge (if equipped)</li> <li>• Odo/trip meter</li> <li>• Indicator lamps</li> <li>• Warning chime</li> </ul>
IPDM E/R	IPDM E/R reads the ON/OFF signals of the oil pressure switch and transmits the oil pressure switch signal to the combination meter via BCM with CAN communication line.
Fuel level sensor unit	Refer to <a href="#">MWI-36. "Description"</a> .

# METER SYSTEM

## < FUNCTION DIAGNOSIS >

Unit	Description
Oil pressure switch	Refer to <a href="#">MWI-39, "Description"</a> .
ECM	Transmits the following signals to the combination meter with CAN communication line. <ul style="list-style-type: none"> <li>• Engine speed signal</li> <li>• Engine coolant temperature signal</li> <li>• Fuel consumption monitor signal</li> </ul>
ABS actuator and electric unit (control unit)	Transmits the vehicle speed signal to the combination meter with CAN communication line.
BCM	<ul style="list-style-type: none"> <li>• Transmits signals provided by various units to the combination meter with CAN communication line.</li> <li>• Transmits the security signal to the combination meter.</li> </ul>
TCM	<ul style="list-style-type: none"> <li>• Transmits shift position signal to the combination meter with CAN communication line.</li> <li>• Transmits A/T oil temperature signal to the combination meter with CAN communication line.</li> </ul>
Washer level switch	Transmits the washer level signal to the combination meter.
Brake fluid level switch	Transmits the brake fluid level switch signal to the combination meter.
Parking brake switch	Refer to <a href="#">MWI-40, "Description"</a> .

## SPEEDOMETER

### SPEEDOMETER : System Diagram

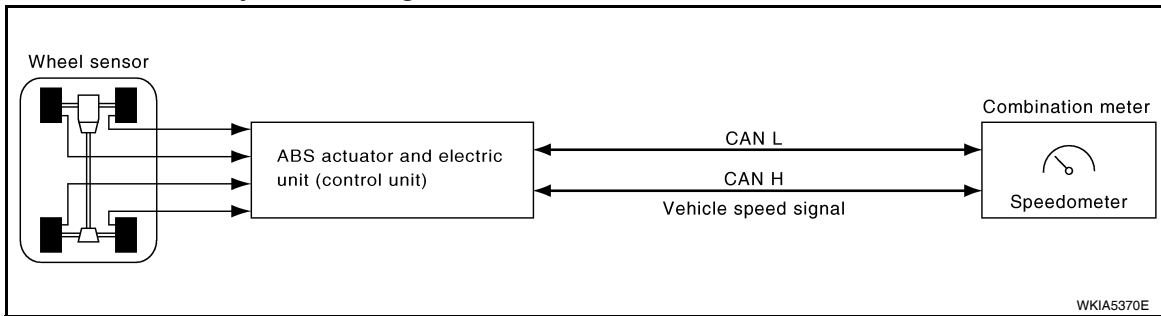

### SPEEDOMETER : System Description

INFOID:000000003790393

The ABS actuator and electric unit (control unit) provides a vehicle speed signal to the combination meter via CAN communication lines.



# METER SYSTEM

< FUNCTION DIAGNOSIS >

## SPEEDOMETER : Component Parts Location

INFOID:000000004215479

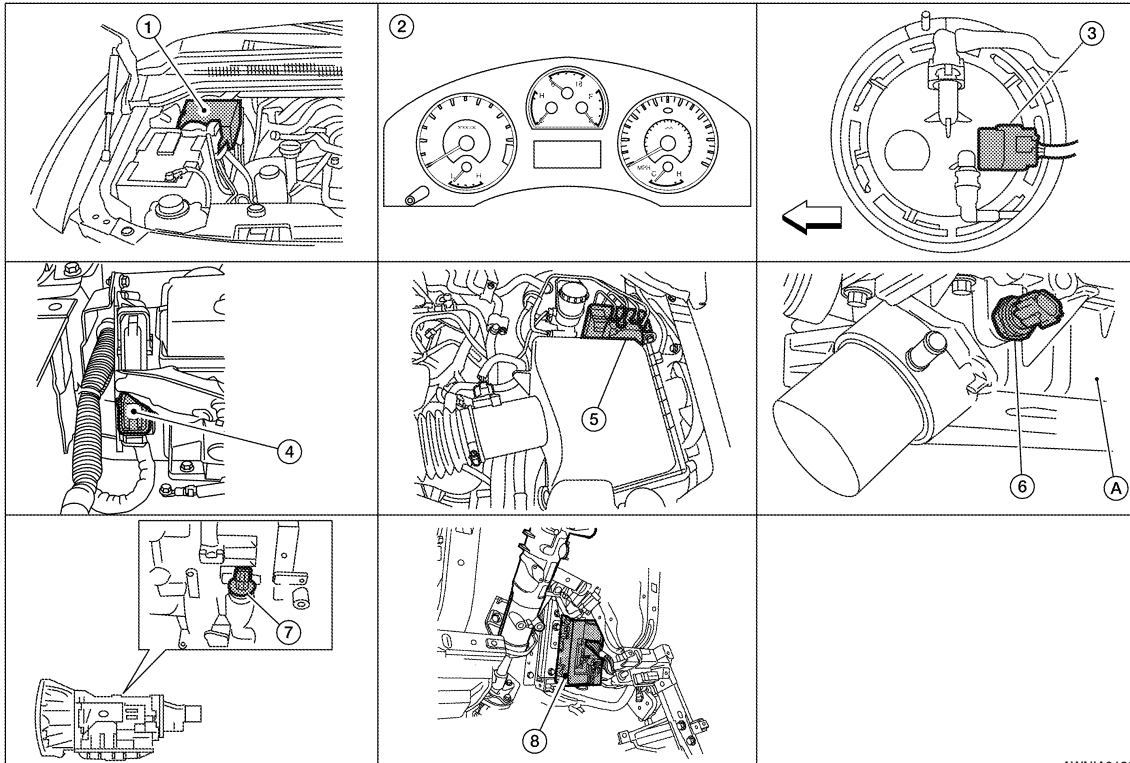

AWNIA0190ZZ

- |   |   |   |
|---|---|---|
| 1. IPDM E/R E122, E124  | 2. Combination meter M24, M25   | 3. Fuel level sensor unit and fuel pump<br>(view with fuel tank removed)<br>C7 (with Flexible Fuel)<br>C5 (without Flexible Fuel)<br>←: Front |
| 4. ECM E16 (view with battery removed)                              | 5. ABS actuator and electric unit (control unit)<br>E126 (with VDC)<br>E125 (without VDC) | 6. Oil pressure switch F4<br>A: Oil pan (upper)   |
| 7. A/T assembly<br>F9 (with floor shift)<br>F17 (with column shift) | 8. BCM M18, M19 (view with instrument lower panel LH removed)                             |   |

## SPEEDOMETER : Component Description

INFOID:0000000003790395

Unit	Description
Combination meter	Indicates the vehicle speed according to the vehicle speed signal received from ABS actuator and electric unit (control unit) via CAN communication.
ABS actuator and electric unit (control unit)	Transmits the vehicle speed signal to the combination meter with CAN communication line.

## TACHOMETER

# METER SYSTEM

< FUNCTION DIAGNOSIS >

## TACHOMETER : System Diagram

INFOID:000000003790396

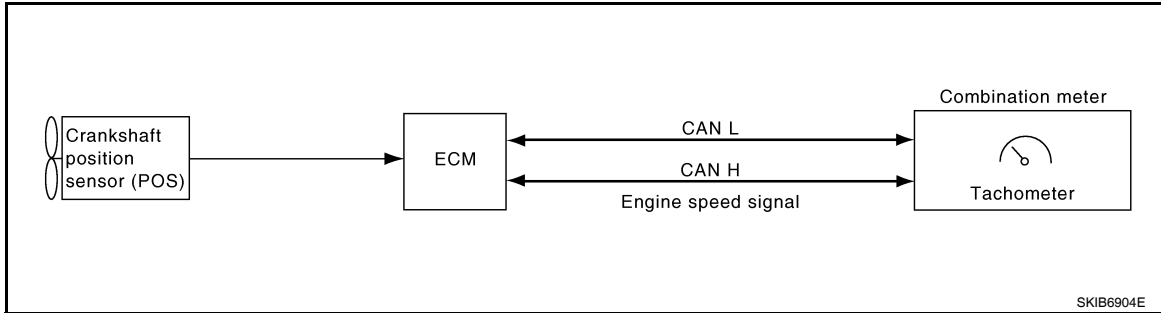

SKIB6904E

## TACHOMETER : System Description

INFOID:000000003790397

The tachometer indicates engine speed in revolutions per minute (rpm).  
The ECM provides an engine speed signal to the combination meter via CAN communication lines.

## TACHOMETER : Component Parts Location

INFOID:000000004215480

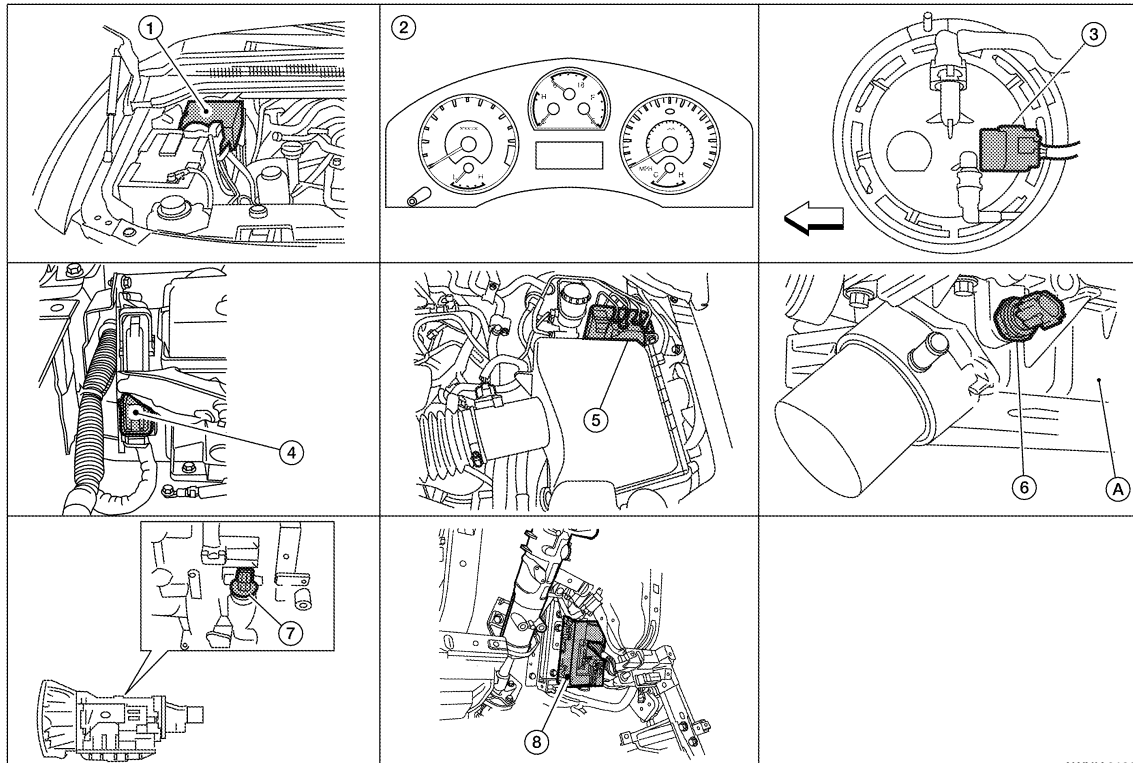

AWNIA0190ZZ

- |   |   |  |
|---|---|--|
| 1. IPDM E/R E122, E124  | 2. Combination meter M24, M25   | 3. Fuel level sensor unit and fuel pump (view with fuel tank removed)<br>C7 (with Flexible Fuel)<br>C5 (without Flexible Fuel)<br>←: Front |
| 4. ECM E16 (view with battery removed)                              | 5. ABS actuator and electric unit (control unit)<br>E126 (with VDC)<br>E125 (without VDC) | 6. Oil pressure switch F4<br>A: Oil pan (upper)  |
| 7. A/T assembly<br>F9 (with floor shift)<br>F17 (with column shift) | 8. BCM M18, M19 (view with instrument lower panel LH removed)                             |  |

# METER SYSTEM

< FUNCTION DIAGNOSIS >

## TACHOMETER : Component Description

INFOID:000000003790399

Unit	Description
Combination meter	Indicates the engine speed in RPM according to the engine speed signal received from ECM via CAN communication.
ECM	Transmits the engine speed signal to the combination meter with CAN communication line.

## ENGINE COOLANT TEMPERATURE GAUGE

### ENGINE COOLANT TEMPERATURE GAUGE : System Diagram

INFOID:000000003790400

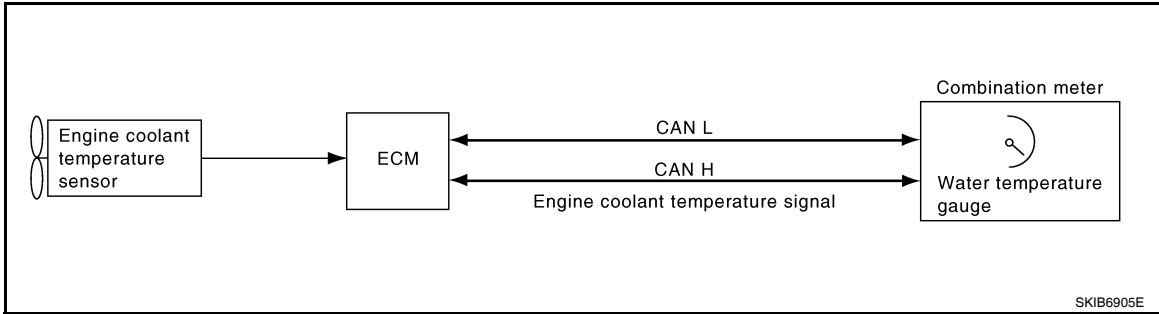

### ENGINE COOLANT TEMPERATURE GAUGE : System Description

INFOID:000000003790401

The engine coolant temperature gauge indicates the engine coolant temperature. The ECM provides an engine coolant temperature signal to the combination meter via CAN communication lines.

### ENGINE COOLANT TEMPERATURE GAUGE : Component Parts Location

INFOID:000000004215481

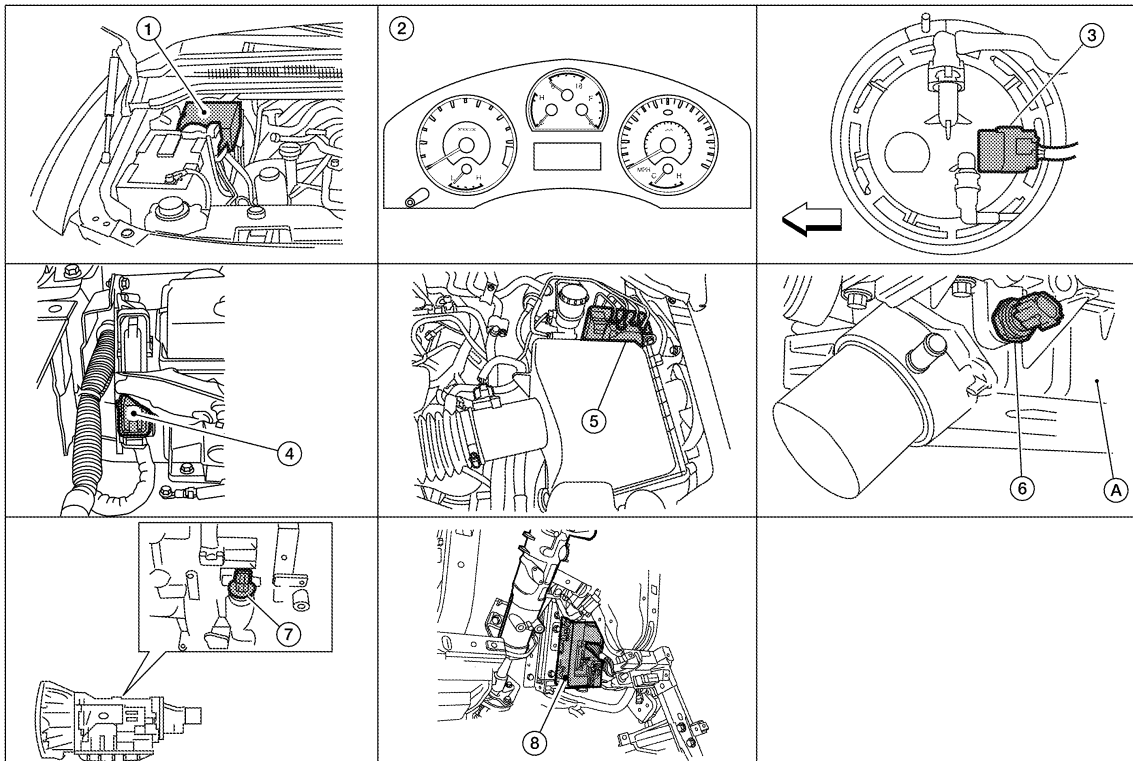

AWNIA0190ZZ

A  
B  
C  
D  
E  
F  
G  
H  
I  
J  
K  
L  
M  
N  
O  
P

MWI

# METER SYSTEM

## < FUNCTION DIAGNOSIS >

- |   |   |  |
|---|---|--|
| 1. IPDM E/R E122, E124  | 2. Combination meter M24, M25   | 3. Fuel level sensor unit and fuel pump (view with fuel tank removed)<br>C7 (with Flexible Fuel)<br>C5 (without Flexible Fuel)<br>←: Front |
| 4. ECM E16 (view with battery removed)                              | 5. ABS actuator and electric unit (control unit)<br>E126 (with VDC)<br>E125 (without VDC) | 6. Oil pressure switch F4<br>A: Oil pan (upper)  |
| 7. A/T assembly<br>F9 (with floor shift)<br>F17 (with column shift) | 8. BCM M18, M19 (view with instrument lower panel LH removed)                             |  |

## ENGINE COOLANT TEMPERATURE GAUGE : Component Description

INFOID:000000003790403

Unit	Description
Combination meter	Indicates the engine coolant temperature according to the engine coolant temperature signal received from ECM via CAN communication.
ECM	Transmits the engine coolant temperature signal to the combination meter via CAN communication.

## FUEL GAUGE

### FUEL GAUGE : System Diagram

INFOID:000000003790404

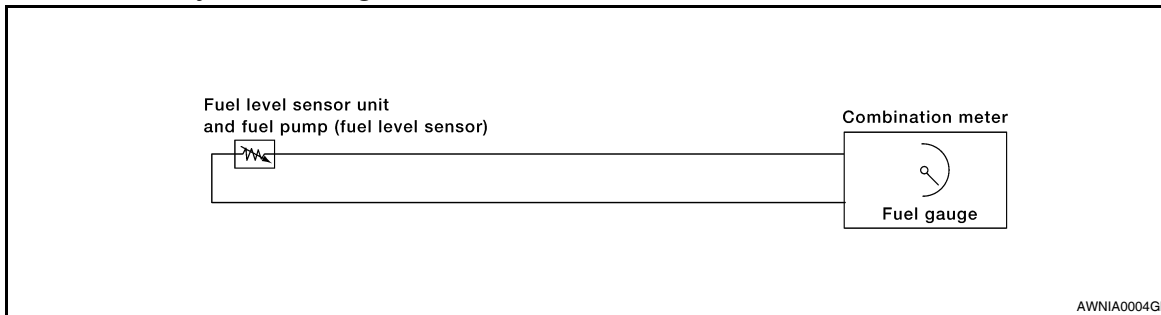

### FUEL GAUGE : System Description

INFOID:000000003790405

The fuel gauge indicates the approximate fuel level in the fuel tank. The fuel gauge is regulated by the unified meter control unit and a variable resistor signal supplied by the fuel level sensor unit.

# METER SYSTEM

< FUNCTION DIAGNOSIS >

## FUEL GAUGE : Component Parts Location

INFOID:000000004215482

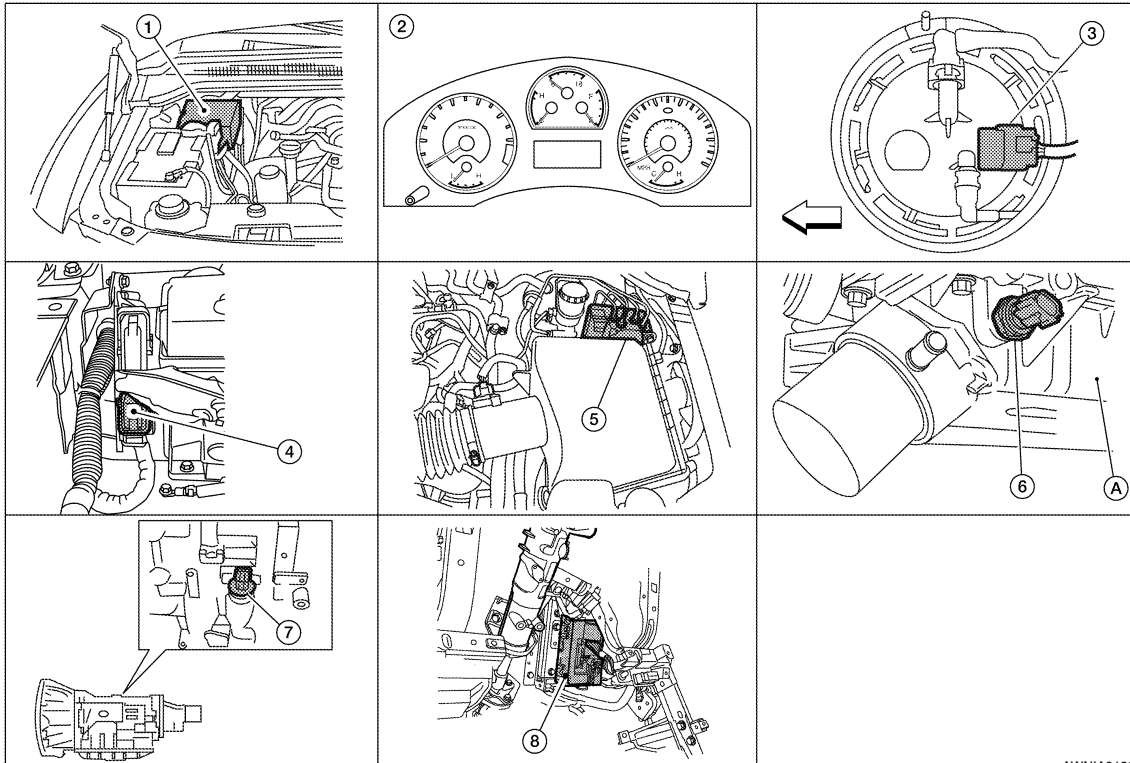

AWNIA0190ZZ

- |   |   |   |
|---|---|---|
| 1. IPDM E/R E122, E124  | 2. Combination meter M24, M25   | 3. Fuel level sensor unit and fuel pump<br>(view with fuel tank removed)<br>C7 (with Flexible Fuel)<br>C5 (without Flexible Fuel)<br>←: Front |
| 4. ECM E16 (view with battery removed)                              | 5. ABS actuator and electric unit (control unit)<br>E126 (with VDC)<br>E125 (without VDC) | 6. Oil pressure switch F4<br>A: Oil pan (upper)   |
| 7. A/T assembly<br>F9 (with floor shift)<br>F17 (with column shift) | 8. BCM M18, M19 (view with instrument lower panel LH removed)                             |   |

## FUEL GAUGE : Component Description

INFOID:0000000003790407

Unit	Description
Combination meter	Indicates the fuel level according to the fuel level sensor signal received from the fuel level sensor unit.
Fuel level sensor unit	Refer to <a href="#">MWI-36. "Description"</a> .

## ENGINE OIL PRESSURE GAUGE

# METER SYSTEM

< FUNCTION DIAGNOSIS >

## ENGINE OIL PRESSURE GAUGE : System Diagram

INFOID:000000003790408

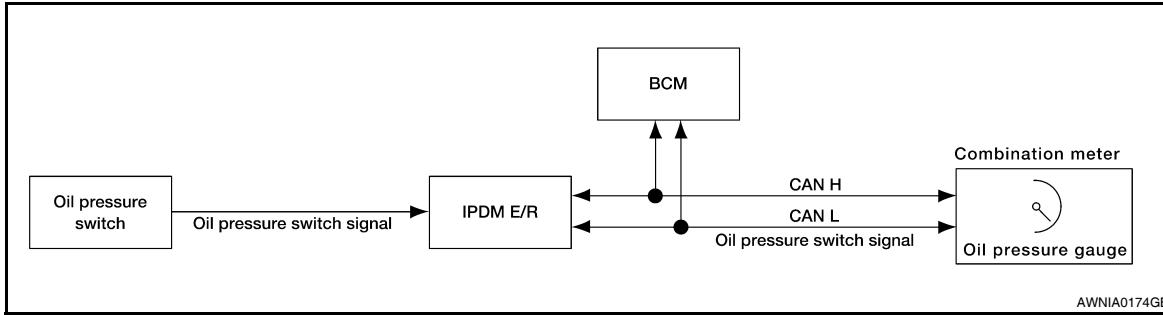

AWNIA0174GE

## ENGINE OIL PRESSURE GAUGE : System Description

INFOID:000000003790409

The engine oil pressure gauge indicates whether the engine oil pressure is low or normal. The oil pressure gauge is controlled by the IPDM E/R. The IPDM E/R reads the ON/OFF signals from the oil pressure switch and transmits the oil pressure switch signal to the combination meter via BCM with the CAN communication line. The oil pressure gauge displays a low or normal indication according to the oil pressure switch signal received via CAN communication.

## ENGINE OIL PRESSURE GAUGE : Component Parts Location

INFOID:000000004215483

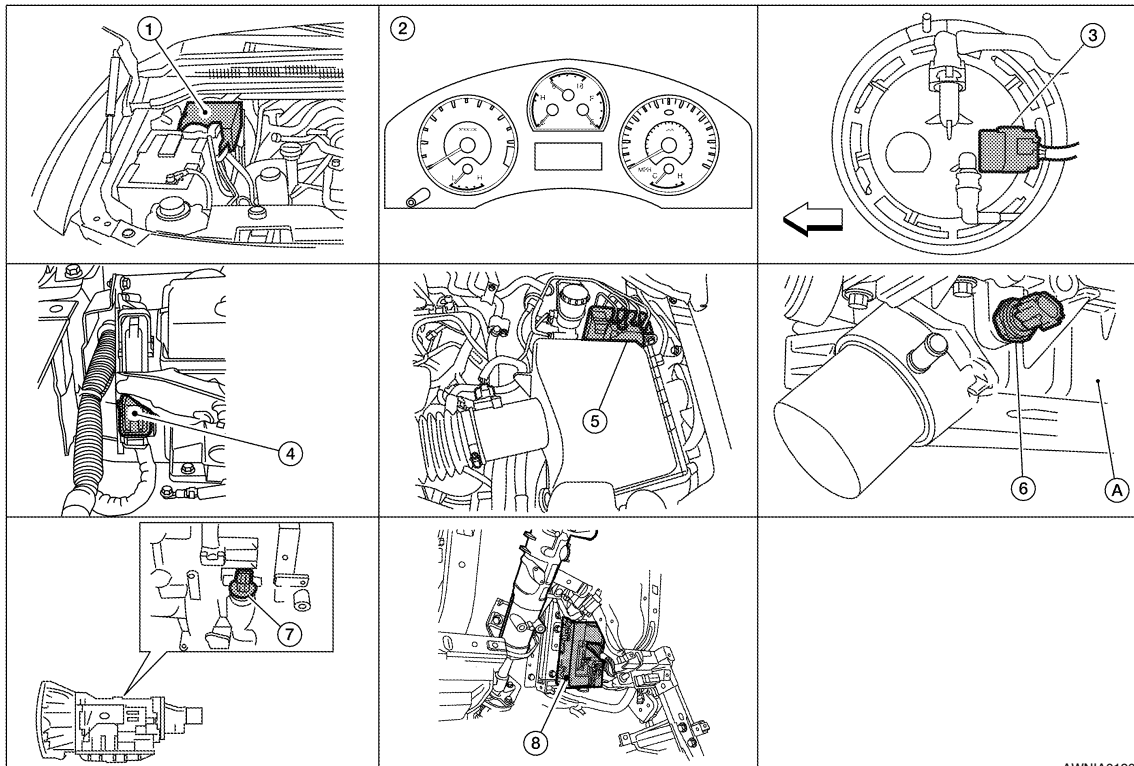

AWNIA0190ZZ

1. IPDM E/R E122, E124

2. Combination meter M24, M25

3. Fuel level sensor unit and fuel pump  
(view with fuel tank removed)  
C7 (with Flexible Fuel)  
C5 (without Flexible Fuel)  
←: Front

# METER SYSTEM

## < FUNCTION DIAGNOSIS >

- |   |   |   |
|---|---|---|
| 4. ECM E16 (view with battery removed)                              | 5. ABS actuator and electric unit (control unit)<br>E126 (with VDC)<br>E125 (without VDC) | 6. Oil pressure switch F4<br>A: Oil pan (upper) |
| 7. A/T assembly<br>F9 (with floor shift)<br>F17 (with column shift) | 8. BCM M18, M19 (view with instrument lower panel LH removed)                             |   |

## ENGINE OIL PRESSURE GAUGE : Component Description

INFOID:000000003790411

Unit	Description
Combination meter	Indicates the engine oil pressure (low/normal) according to the oil pressure switch signal received from BCM with CAN communication line.
IPDM E/R	Reads the ON/OFF signals from the oil pressure switch and transmits the oil pressure switch signal to the combination meter via BCM with the CAN communication line.
Oil pressure switch	Refer to <a href="#">MWI-39. "Description"</a> .
BCM	Transmits the oil pressure switch signal received from IPDM E/R via CAN communication to the combination meter via CAN communication.

## A/T OIL TEMPERATURE GAUGE

### A/T OIL TEMPERATURE GAUGE : System Diagram

INFOID:000000003790412

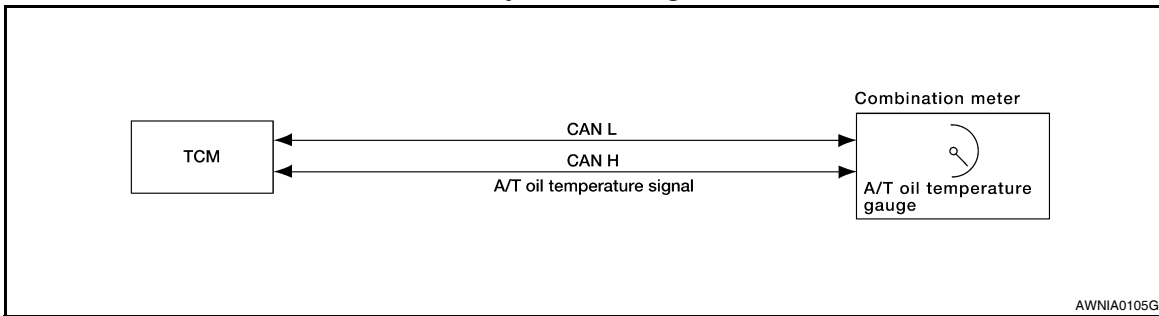

### A/T OIL TEMPERATURE GAUGE : System Description

INFOID:000000003790413

The A/T oil temperature gauge indicates the A/T fluid temperature.  
The TCM (transmission control module) provides an A/T fluid temperature signal to combination meter via CAN communication lines.

A  
B  
C  
D  
E  
F  
G  
H  
I  
J  
K  
L  
M  
O  
P

MWI

# METER SYSTEM

< FUNCTION DIAGNOSIS >

## A/T OIL TEMPERATURE GAUGE : Component Parts Location

INFOID:000000004215484

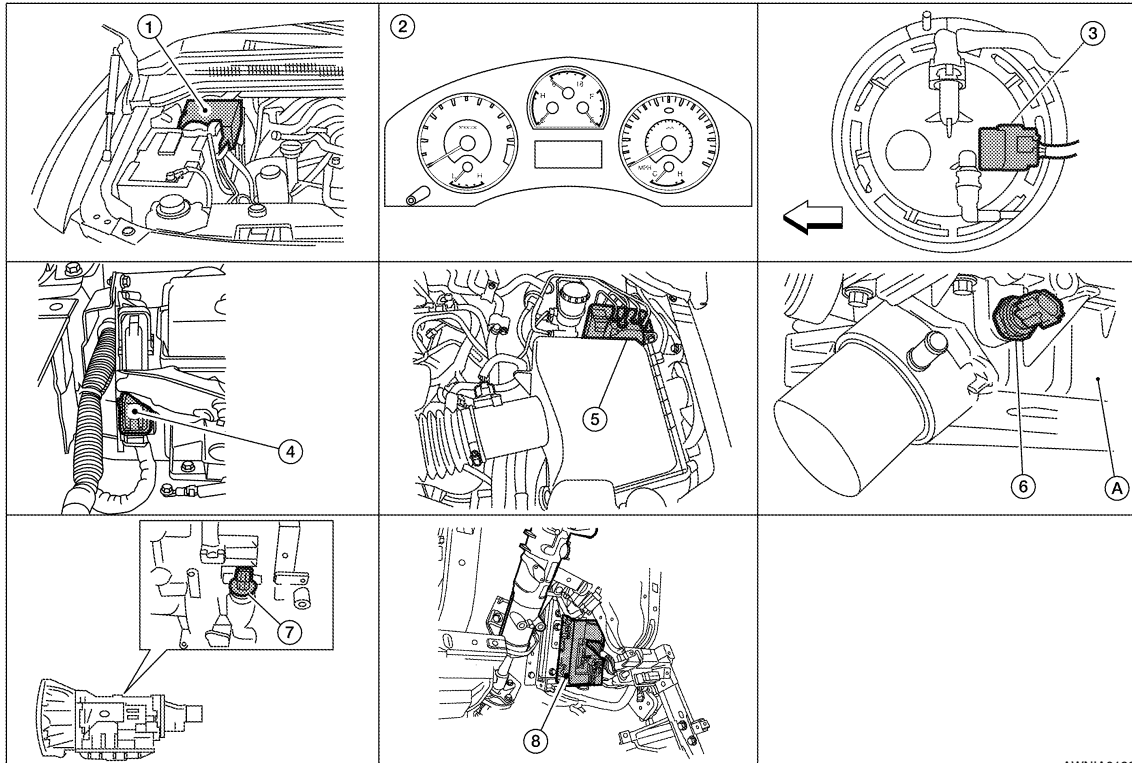

AWNIA0190ZZ

- |   |   |   |
|---|---|---|
| 1. IPDM E/R E122, E124  | 2. Combination meter M24, M25   | 3. Fuel level sensor unit and fuel pump<br>(view with fuel tank removed)<br>C7 (with Flexible Fuel)<br>C5 (without Flexible Fuel)<br>⇐: Front |
| 4. ECM E16 (view with battery removed)                              | 5. ABS actuator and electric unit (control unit)<br>E126 (with VDC)<br>E125 (without VDC) | 6. Oil pressure switch F4<br>A: Oil pan (upper)   |
| 7. A/T assembly<br>F9 (with floor shift)<br>F17 (with column shift) | 8. BCM M18, M19 (view with instrument lower panel LH removed)                             |   |

## A/T OIL TEMPERATURE GAUGE : Component Description

INFOID:000000003790415

Unit	Description
Combination meter	Indicates the A/T oil temperature according to the A/T oil temperature signal received from TCM via CAN communication.
TCM	Transmits the A/T oil temperature signal to the combination meter via CAN communication.

## VOLTAGE GAUGE



# METER SYSTEM

< FUNCTION DIAGNOSIS >

## VOLTAGE GAUGE : System Diagram

INFOID:000000003790416

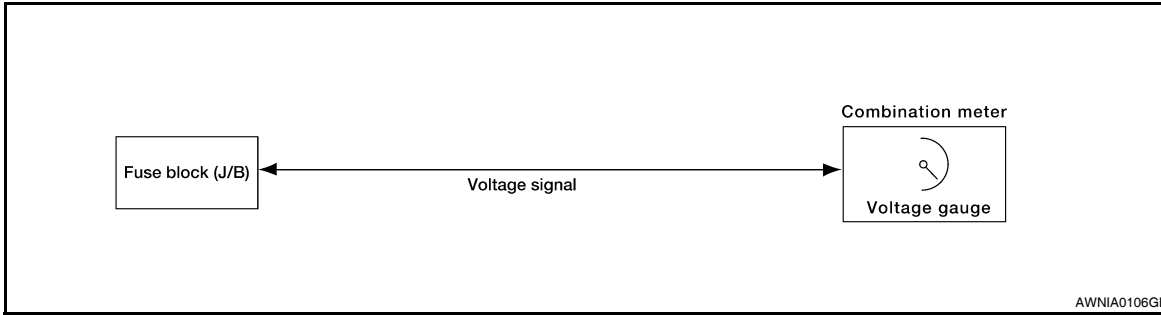

AWNIA0106GE

## VOLTAGE GAUGE : System Description

INFOID:000000003790417

The voltage gauge indicates the battery/charging system voltage. The voltage gauge is regulated by the unified meter control unit.

## VOLTAGE GAUGE : Component Parts Location

INFOID:000000004215485

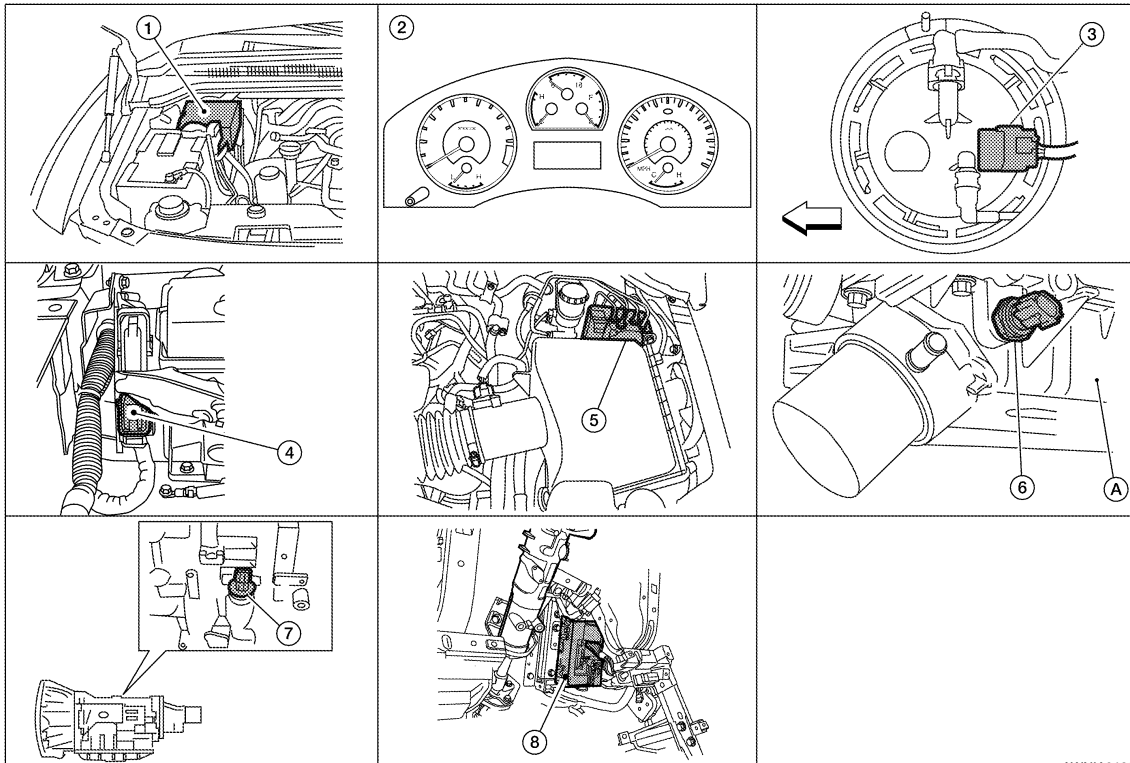

AWNIA0190ZZ

- |   |   |  |
|---|---|--|
| 1. IPDM E/R E122, E124  | 2. Combination meter M24, M25   | 3. Fuel level sensor unit and fuel pump (view with fuel tank removed)<br>C7 (with Flexible Fuel)<br>C5 (without Flexible Fuel)<br>←: Front |
| 4. ECM E16 (view with battery removed)                              | 5. ABS actuator and electric unit (control unit)<br>E126 (with VDC)<br>E125 (without VDC) | 6. Oil pressure switch F4<br>A: Oil pan (upper)  |
| 7. A/T assembly<br>F9 (with floor shift)<br>F17 (with column shift) | 8. BCM M18, M19 (view with instrument lower panel LH removed)                             |  |

A  
B  
C  
D  
E  
F  
G  
H  
I  
J  
K  
L  
M

MWI

O  
P

# METER SYSTEM

< FUNCTION DIAGNOSIS >

## VOLTAGE GAUGE : Component Description

INFOID:000000003790419

Unit	Description
Combination meter	Indicates the battery voltage according to the voltage signal received from the fuse block (J/B).
Fuse block (J/B)	Transmits the battery voltage signal to the combination meter.

## ODO/TRIP METER

### ODO/TRIP METER : System Diagram

INFOID:000000003790420

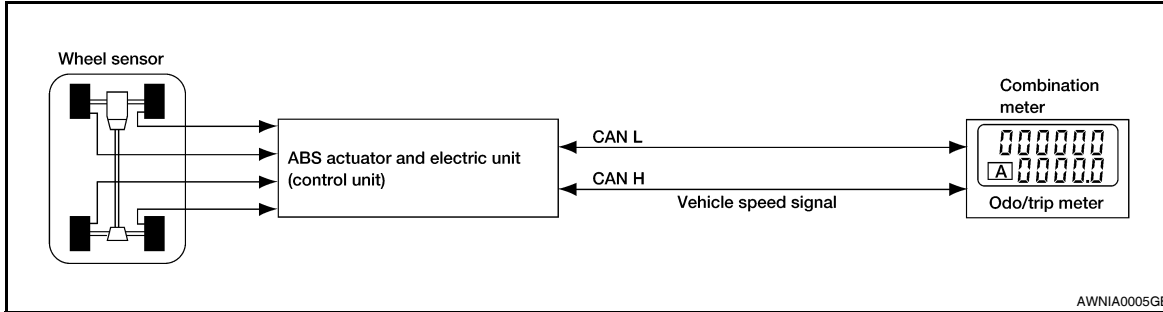

AWNIA0005GE

### ODO/TRIP METER : System Description

INFOID:000000003790421

The vehicle speed signal and the memory signals from the meter memory circuit are processed by the combination meter and the mileage is displayed.

### HOW TO CHANGE THE DISPLAY FOR ODO/TRIP METER

Refer to Owner's Manual for odo/trip meter operating instructions.

### ODO/TRIP METER : Component Parts Location

INFOID:000000004215486

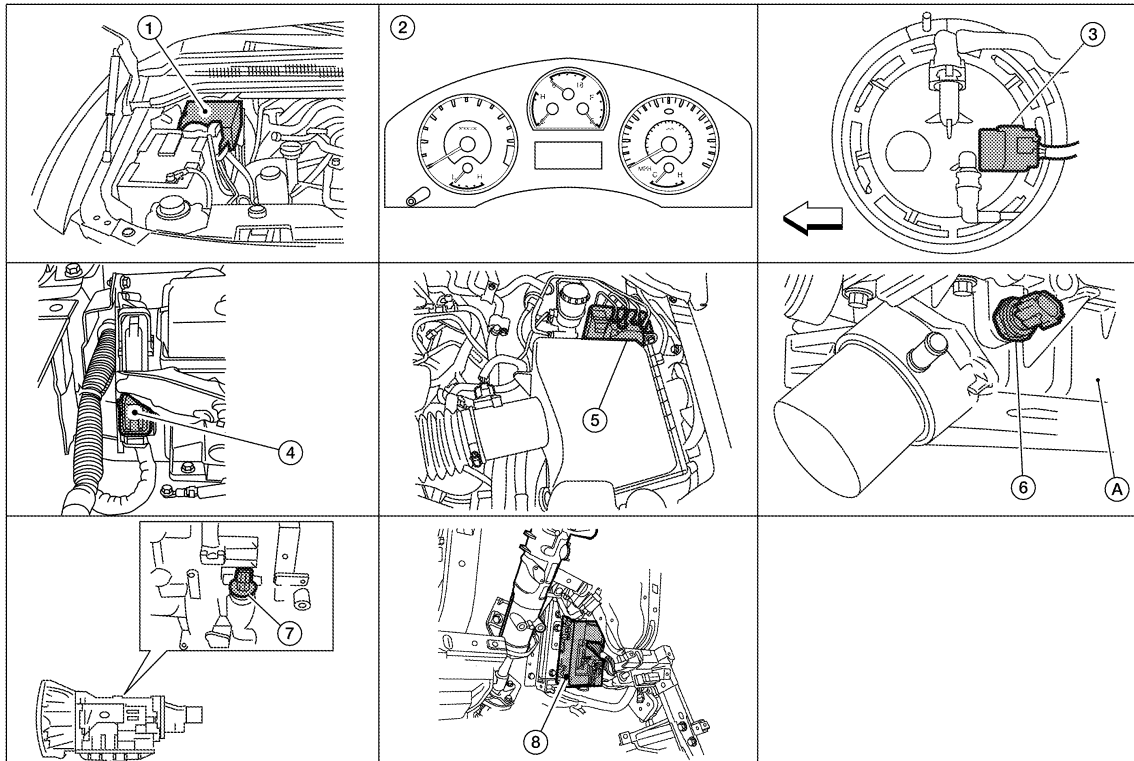

AWNIA0190ZZ

# METER SYSTEM

## < FUNCTION DIAGNOSIS >

- |   |   |   |
|---|---|---|
| 1. IPDM E/R E122, E124  | 2. Combination meter M24, M25   | 3. Fuel level sensor unit and fuel pump<br>(view with fuel tank removed)<br>C7 (with Flexible Fuel)<br>C5 (without Flexible Fuel)<br>←: Front |
| 4. ECM E16 (view with battery removed)                              | 5. ABS actuator and electric unit (control unit)<br>E126 (with VDC)<br>E125 (without VDC) | 6. Oil pressure switch F4<br>A: Oil pan (upper)   |
| 7. A/T assembly<br>F9 (with floor shift)<br>F17 (with column shift) | 8. BCM M18, M19 (view with instrument<br>lower panel LH removed)                          |   |

## ODO/TRIP METER : Component Description

INFOID:000000003790423

Unit	Description
Combination meter	Converts the vehicle speed signal received from the ABS actuator and electric unit (control unit) via CAN communication to mileage, and it displays the accumulated mileage to the odo/trip meter.
ABS actuator and electric unit (control unit)	Transmits the vehicle speed signal to the combination meter via CAN communication.

## SHIFT POSITION INDICATOR

### SHIFT POSITION INDICATOR : System Diagram

INFOID:000000003790424

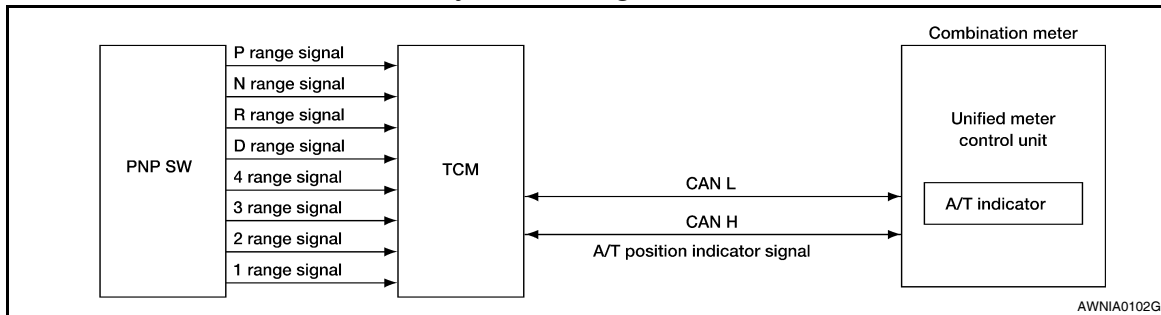

### SHIFT POSITION INDICATOR : System Description

INFOID:000000003790425

The TCM receives A/T indicator signals from the park/neutral position (PNP) switch. The TCM then sends A/T position indicator signals to the combination meter via CAN communication lines. The combination meter indicates the received shift position.

# METER SYSTEM

< FUNCTION DIAGNOSIS >

## SHIFT POSITION INDICATOR : Component Parts Location

INFOID:000000004215487

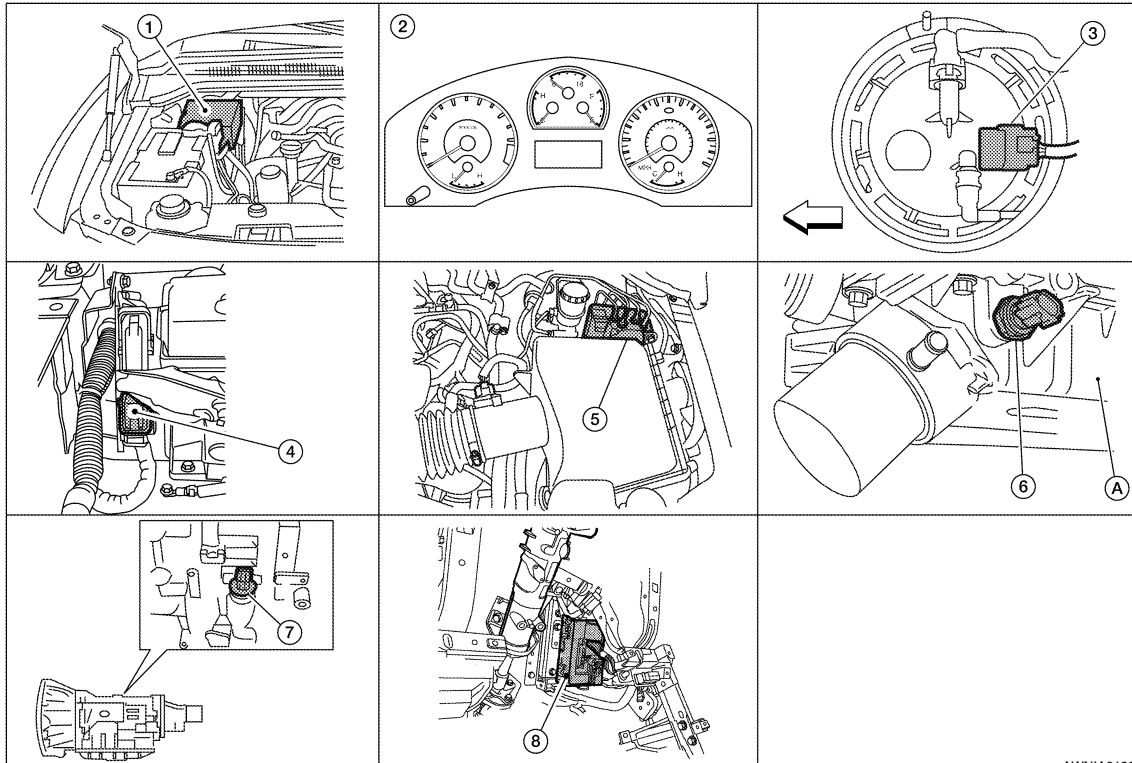

AWNIA0190ZZ

- |   |   |   |
|---|---|---|
| 1. IPDM E/R E122, E124  | 2. Combination meter M24, M25   | 3. Fuel level sensor unit and fuel pump<br>(view with fuel tank removed)<br>C7 (with Flexible Fuel)<br>C5 (without Flexible Fuel)<br>⇐: Front |
| 4. ECM E16 (view with battery removed)                              | 5. ABS actuator and electric unit (control unit)<br>E126 (with VDC)<br>E125 (without VDC) | 6. Oil pressure switch F4<br>A: Oil pan (upper)   |
| 7. A/T assembly<br>F9 (with floor shift)<br>F17 (with column shift) | 8. BCM M18, M19 (view with instrument lower panel LH removed)                             |   |

## SHIFT POSITION INDICATOR : Component Description

INFOID:000000003790427

Unit	Description
Combination meter	Displays the shift position on the information display using shift position signal received from TCM.
TCM	Transmits the shift position signal to the combination meter via CAN communication.

## WARNING LAMPS/INDICATOR LAMPS

# METER SYSTEM

< FUNCTION DIAGNOSIS >

## WARNING LAMPS/INDICATOR LAMPS : System Diagram

INFOID:000000003790428

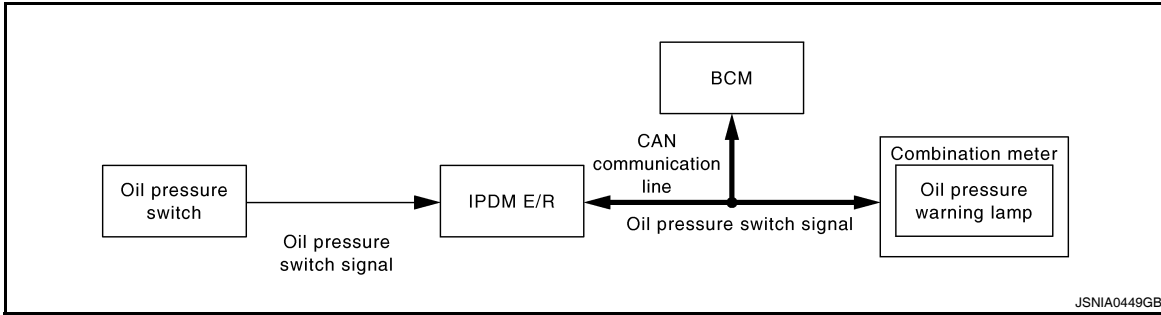

JSNIA0449GB

## WARNING LAMPS/INDICATOR LAMPS : System Description

INFOID:000000003790429

### OIL PRESSURE WARNING LAMP

- IPDM E/R reads the ON/OFF signals from the oil pressure switch and transmits the oil pressure switch signal to the combination meter via BCM with the CAN communication line.
- The combination meter turns the oil pressure warning lamp ON/OFF according to the oil pressure switch signal received via CAN communication.

## WARNING LAMPS/INDICATOR LAMPS : Component Parts Location

INFOID:000000004215488

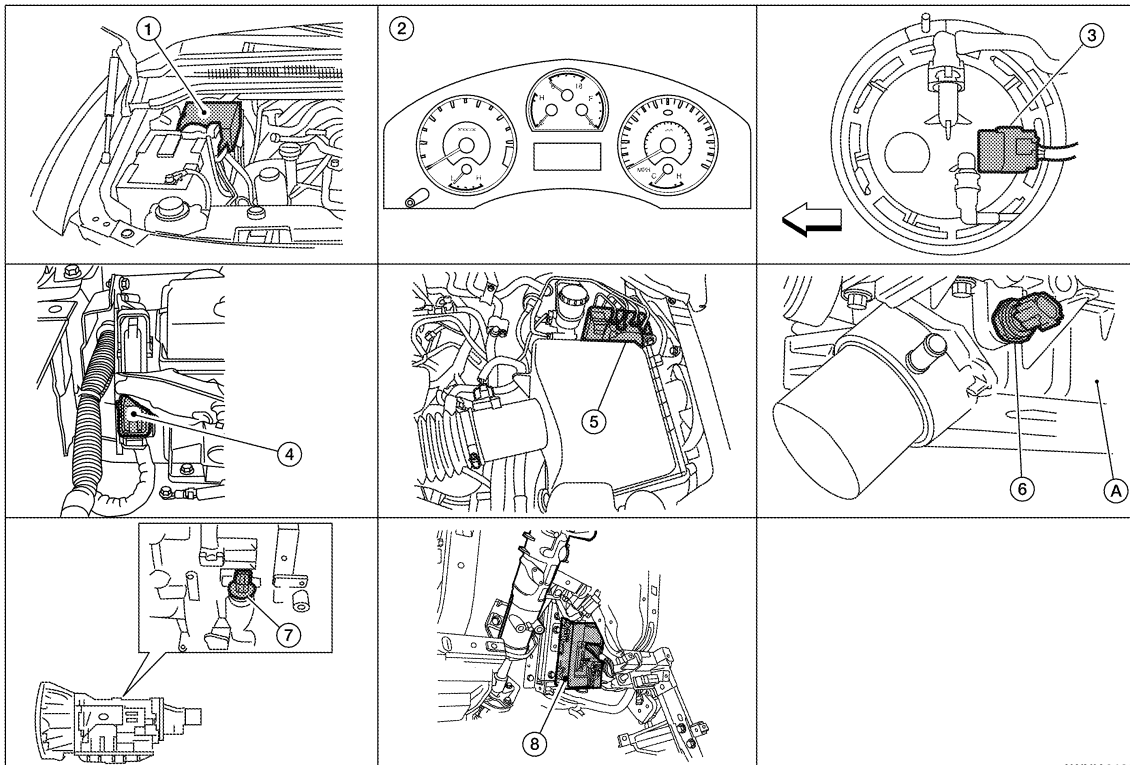

1. IPDM E/R E122, E124

2. Combination meter M24, M25

3. Fuel level sensor unit and fuel pump  
 (view with fuel tank removed)  
 C7 (with Flexible Fuel)  
 C5 (without Flexible Fuel)  
 ⇐: Front

AWNIA0190ZZ

# METER SYSTEM

## < FUNCTION DIAGNOSIS >

- |   |   |   |
|---|---|---|
| 4. ECM E16 (view with battery removed)                              | 5. ABS actuator and electric unit (control unit)<br>E126 (with VDC)<br>E125 (without VDC) | 6. Oil pressure switch F4<br>A: Oil pan (upper) |
| 7. A/T assembly<br>F9 (with floor shift)<br>F17 (with column shift) | 8. BCM M18, M19 (view with instrument lower panel LH removed)                             |   |

## WARNING LAMPS/INDICATOR LAMPS : Component Description

INFOID:000000003790431

Unit	Description
Combination meter	Turns the oil pressure warning lamp ON/OFF according to the oil pressure switch signal received from BCM by means of communication.
IPDM E/R	Reads the ON/OFF signals from the oil pressure switch and transmits the oil pressure switch signal to the combination meter via BCM with the CAN communication line.
Oil pressure switch	Refer to <a href="#">MWI-39. "Description"</a> .
BCM	Transmits the oil pressure switch signal received from IPDM E/R via CAN communication to the combination meter via CAN communication.

## INFORMATION DISPLAY

### INFORMATION DISPLAY : System Diagram

INFOID:000000003790432

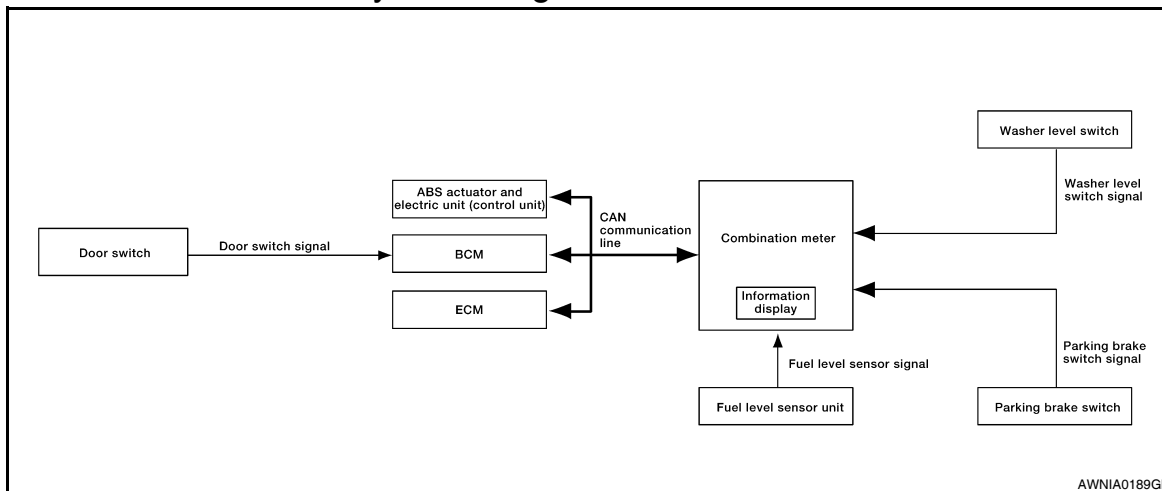

### INFORMATION DISPLAY : System Description

INFOID:000000003790433

#### FUNCTION

The information display can indicate the following items.

- Trip/fuel consumption readings
- Maintenance information
- Warning/Indication messages (Door open, low fuel, low washer fluid, parking brake)

#### MPG

Average fuel consumption indication is calculated using vehicle speed signals from the ABS actuator and electric unit (control unit) and fuel consumption information from the ECM.

#### TIME/MILES

The travel time and distance since last reset is displayed.

#### MPG/MPH

The average speed mode can be selected to display the average fuel consumption and average speed since last reset. The indications are calculated using vehicle speed signals from the ABS actuator and electric unit (control unit) and fuel consumption information from the ECM.

#### RANGE

# METER SYSTEM

## < FUNCTION DIAGNOSIS >

The range indication provides the driver with an estimation of the distance that can be driven before refueling. The range is calculated using signals from the fuel level sensor unit (fuel remaining), ECM (fuel consumption) and vehicle speed signals from the ABS actuator and electric unit (control unit).

### DOOR OPEN WARNING

This warning appears when the ignition switch is ON and the front door LH, front door RH, rear door LH (crew cab) or rear door RH (crew cab) is opened. The BCM receives a door switch signal from the front door switch LH, front door switch RH, rear door switch LH (crew cab) and rear door switch RH (crew cab). The BCM sends the door switch signal to the combination meter via CAN communication lines. Then, when the ignition switch is turned ON, the warning message is displayed.

### LOW FUEL WARNING

This warning appears when the fuel level in the fuel tank is less than approximately 11.4 ℓ (3 US gal, 2.5 Imp gal). A variable resistor signal is supplied to the combination meter from the fuel level sensor unit to determine the amount of fuel in the fuel tank.

### LOW WINDSHIELD WASHER FLUID WARNING

This warning appears when the windshield washer fluid level is low. When the windshield washer fluid level is low, the washer level switch provides a ground signal to the combination meter (unified meter control unit). Once fluid is added, the message will stay on for 30 seconds and then turn off.

### PARKING BRAKE INDICATOR

When the parking brake is applied, the parking brake switch provides a ground signal to the combination meter (unified meter control unit). Then, when the ignition switch is turned ON and vehicle speed is greater than 7 km/h (4 MPH), the message is displayed.

Refer to Owner's Manual for additional information display items.

## INFORMATION DISPLAY : Component Parts Location

INFOID:000000004215489

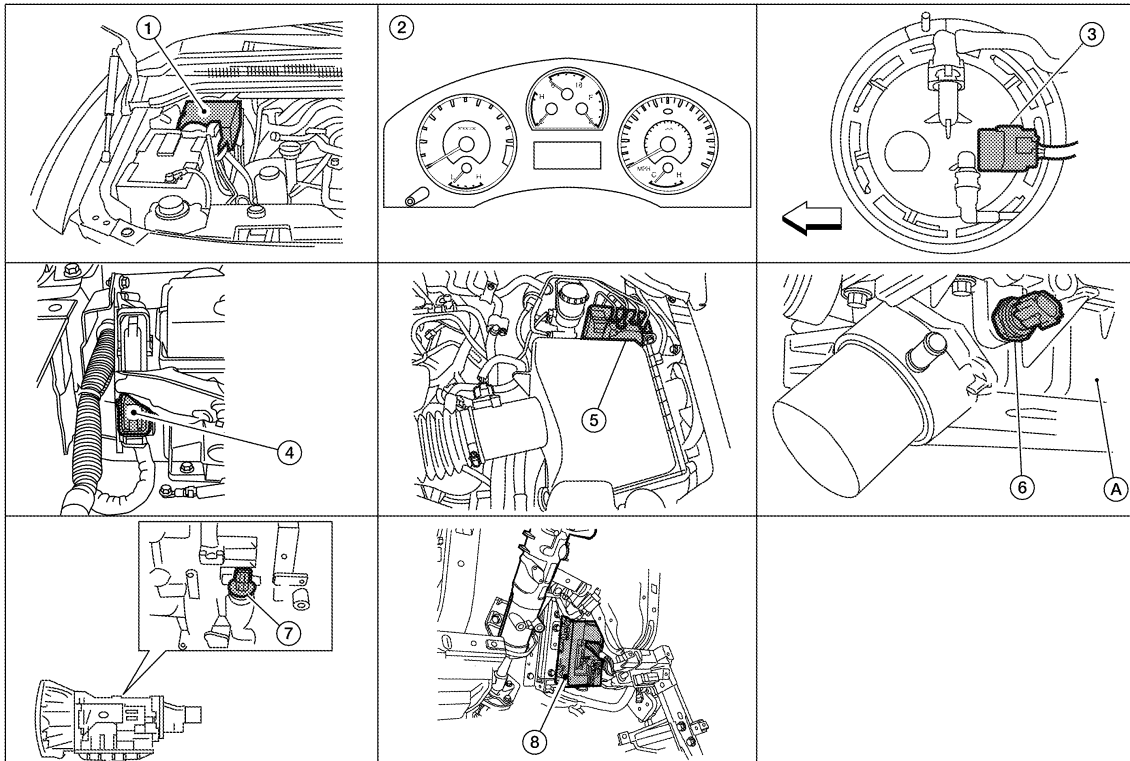

AWNIA0190ZZ

A  
B  
C  
D  
E  
F  
G  
H  
I  
J  
K  
L  
M  
N  
O  
P

MWI

# METER SYSTEM

## < FUNCTION DIAGNOSIS >

- |   |   |   |
|---|---|---|
| 1. IPDM E/R E122, E124  | 2. Combination meter M24, M25   | 3. Fuel level sensor unit and fuel pump<br>(view with fuel tank removed)<br>C7 (with Flexible Fuel)<br>C5 (without Flexible Fuel)<br>←: Front |
| 4. ECM E16 (view with battery removed)                              | 5. ABS actuator and electric unit (control unit)<br>E126 (with VDC)<br>E125 (without VDC) | 6. Oil pressure switch F4<br>A: Oil pan (upper)   |
| 7. A/T assembly<br>F9 (with floor shift)<br>F17 (with column shift) | 8. BCM M18, M19 (view with instrument lower panel LH removed)                             |   |

## INFORMATION DISPLAY : Component Description

INFOID:000000003790435

Unit	Description
Combination meter	Controls the information display according to the signal received from each unit.
Fuel level sensor unit	Refer to <a href="#">MWI-36, "Description"</a> .
ECM	Transmits the following signals to the combination meter via CAN communication line. <ul style="list-style-type: none"> <li>• Engine speed signal</li> <li>• Fuel consumption monitor signal</li> </ul>
ABS actuator and electric unit (control unit)	Transmits the vehicle speed signal to the combination meter via CAN communication line.
BCM	Transmits signals provided by various units to the combination meter via CAN communication line.
Washer level switch	Transmits the washer level signal to the combination meter.
Parking brake switch	Refer to <a href="#">MWI-40, "Description"</a> .
Door switch	Transmits the door switch signals to BCM.



# COMPASS

< FUNCTION DIAGNOSIS >

## COMPASS

### Description

INFOID:000000004244567

#### DESCRIPTION

With the ignition switch in the ON position, and the mode or (N) switch ON, the compass display will indicate the direction the vehicle is heading.

Vehicle direction is displayed as follows:

- N: north
- E: east
- S: south
- W: west

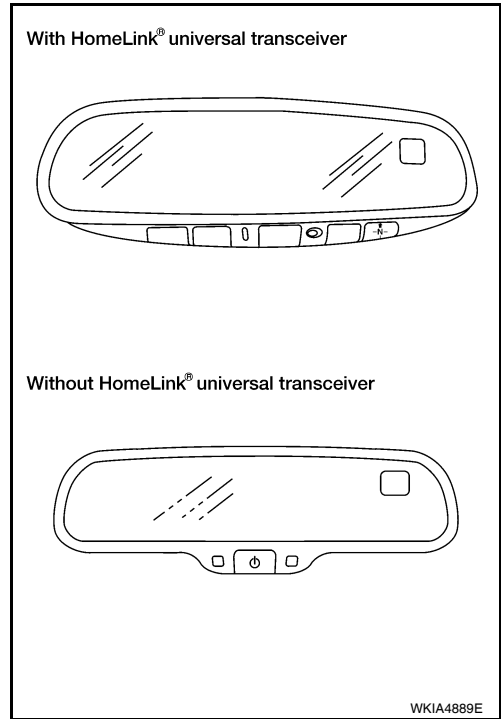

#### ZONE VARIATION SETTING PROCEDURE

The difference between magnetic north and geographical north can sometimes be great enough to cause false compass readings. This difference is known as variance. In order for the compass to operate properly (accurately) in a particular zone, the zone variation must be calibrated using the following procedure.

Zone Variation Chart

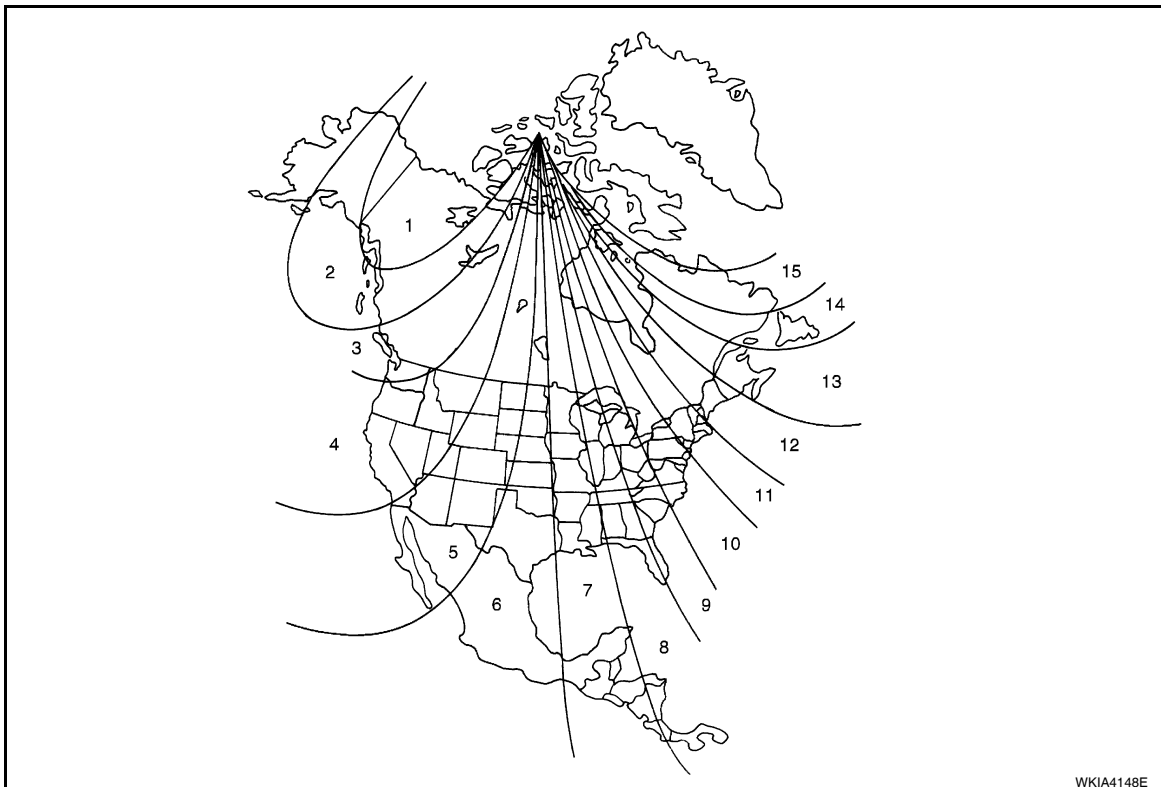

A  
B  
C  
D  
E  
F  
G  
H  
I  
J  
K  
L  
M  
N  
O  
P

# COMPASS

## < FUNCTION DIAGNOSIS >

1. Determine your location on the zone map.
2. Turn the ignition switch to the ON position.
3. Press and hold the (N) switch for about 8 seconds (with HomeLink universal transceiver) or the mode switch for about 11 seconds (without HomeLink universal transceiver). The current zone number will appear in the display.
4. Press the mode or (N) switch repeatedly until the desired zone number appears in the display.

Once the desired zone number is displayed, stop pressing the mode or (N) switch and the display will show a compass direction after a few seconds.

### NOTE:

Use zone number 5 for Hawaii.

## CALIBRATION PROCEDURE

The compass display is equipped with an automatic correction function. If the compass display reads "CAL" or the direction is not shown correctly, perform the correction procedure below.

1. Press and hold the (N) switch for about 10 seconds (with HomeLink universal transceiver) or the mode switch for about 13 seconds (without HomeLink universal transceiver). The display will read "CAL".
2. Drive the vehicle slowly in a circle, in an open, safe place. The initial calibration is completed in about 3 turns.

### NOTE:

In places where the terrestrial magnetism is extremely disturbed, the initial correction may start automatically.

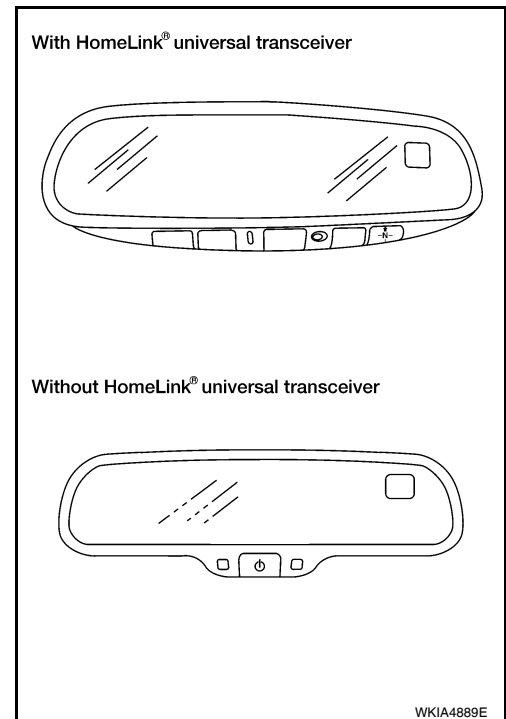

# DIAGNOSIS SYSTEM (METER)

< FUNCTION DIAGNOSIS >

## DIAGNOSIS SYSTEM (METER)

### Diagnosis Description

INFOID:000000003790437

#### SELF-DIAGNOSIS MODE

The following items can be checked during Combination Meter Self-Diagnosis Mode.

- Gauge sweep and present gauge values.
- Illuminates all odometer/trip meters and A/T indicator segments.
- Illuminates all micro controlled lamps/LEDs regardless of switch position.
- Displays estimated present battery voltage.
- Displays seat belt buckle switch LH status.

#### OPERATION PROCEDURE

##### NOTE:

- Once entered, combination meter self-diagnosis mode will function with the ignition switch in ON or START. Combination meter self-diagnosis mode will exit upon turning the ignition switch to OFF or ACC.
- If the diagnosis function is activated with trip A displayed, the mileage on trip A is reset to 0000.0. (Trip B operates the same way.)

To initiate combination meter self-diagnosis mode, refer to the following procedure.

1. Turn the ignition switch ON, while pressing the odometer/trip meter switch for 5 - 8 seconds. When the diagnosis function is activated, the odometer/trip meter will display tEst.

##### NOTE:

Check combination meter power supply and ground circuit when self-diagnosis mode of combination meter does not start. Refer to [MWI-33, "COMBINATION METER : Diagnosis Procedure"](#). Replace combination meter if normal. Refer to [MWI-103, "Removal and Installation"](#).

#### COMBINATION METER SELF-DIAGNOSIS MODE FUNCTIONS

To interpret combination meter self-diagnosis mode functions, refer to the following table.

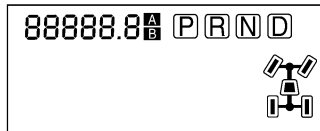
Event	Odometer Display	Description of Test/Data	Notes:
Odometer/trip meter A/B switch held from 5 to 8 seconds (or until released)	tEst		Initiating self-diagnosis mode
Switch released	GAGE	Performs sweep of all gauges, then displays present gauge values.	Gauges sweep within 10 seconds
Switch pressed	(All segments illuminated)	Lights all LCD segments. Compare with picture.	 ALNIA0280ZZ
Switch pressed	bulb	Illuminates all micro-controlled lamps/LEDs.	Part may not be configured for all lamps (functions) that turn on during test. This is normal.
Switch pressed	r XXXX, FAIL	Return to normal operation of all lamps/LEDs and displays "r XXXX".	If a malfunction exists, "FAIL" will flash.
Switch pressed	nrXXXX	Displays Hex ROM rev as stored in NVM.	
Switch pressed	EE XX, FAIL	Displays "EE XX".	If a malfunction exists, "FAIL" will flash.
Switch pressed	dtXXXX	Hex coding of final manufacturing test date.	

A  
B  
C  
D  
E  
F  
G  
H  
I  
J  
K  
L  
M  
N  
O  
P

## DIAGNOSIS SYSTEM (METER)

### < FUNCTION DIAGNOSIS >

Event	Odometer Display	Description of Test/Data	Notes:
Switch pressed (3 times)	Sc1 XX through Epr XX	Displays 8 bit software configuration value in Hex format	
Switch pressed	1nF XX	Displays 8-bit market info value in Hex format.	\$31 = USA \$2A = Canada
Switch pressed (3 times)	cYL XX through tF	N/A	
Switch pressed	ot1 XX	Displays oil pressure tell-tale "" in Hex format.	
Switch pressed	ot0 XX	Displays oil pressure tell-tale "" in Hex format.	
Switch pressed	XXXXX	"Corrected" speed value in hundredths of MPH. Gauge indication may be slightly higher. This is normal.	Will display "----" if message is not received. Will display "99999" if data received is invalid.
Switch pressed	XXXXX	"Corrected" speed value in hundredths of KPH. Gauge indication may be slightly different. This is normal.	Will display "----" if message is not received. Will display "99999" if data received is invalid.
Switch pressed	t XXXX	Tachometer value in RPM. Gauge indication may be higher at higher RPM. This is normal.	Will display "----" if message is not received.
Switch pressed	F1XXXX	Present fuel level A/D input. This input represents fuel sender input.	000-009 = Short circuit 010-254 = Normal range 255 = Open circuit
Switch pressed	F2XXX	Present FLPS.	010-254 = Normal range
Switch pressed	XXXX	Last temperature gauge input value in degrees C. Temperature gauge indicates present temperature per indication standard.	Will display "---"C if message is not received. Will display "999" if data received is invalid. High = 130 deg C Normal = 70 - 105 deg C Low = less than 50 deg C
Switch pressed	BAtXX.X	Estimated present battery voltage.	
Switch pressed	rES -X	Seat belt buckle switch LH status.	1 = Buckled 0 = Unbuckled
Switch pressed (33 times)	PA -XX through PA1-XX	N/A	
Switch pressed	GAGE		Return to beginning of self-diagnosis cycle.

### CONSULT-III Function (METER/M&A)

INFOID:000000003790438

CONSULT-III can display each diagnostic item using the diagnostic test modes shown following.

METER/M&A diagnosis mode	Description
SELF-DIAG RESULTS	Displays combination meter self-diagnosis results.
DATA MONITOR	Displays combination meter input/output data in real time.
CAN DIAG SUPPORT MNTR	The result of transmit/receive diagnosis of CAN communication can be read.

### SELF-DIAG RESULTS

Display Item List

## DIAGNOSIS SYSTEM (METER)

< FUNCTION DIAGNOSIS >

Refer to [MWI-65, "DTC Index"](#).

### DATA MONITOR

Display Item List

X: Applicable

Display item [Unit]	MAIN SIGNALS	SELECTION FROM MENU	Description
SPEED METER [km/h] or [mph]	X	X	Displays the value of vehicle speed signal.
SPEED OUTPUT [km/h] or [mph]	X	X	Displays the value of vehicle speed signal, which is transmitted to each unit with CAN communication.
TACHO METER [rpm]	X	X	Displays the value of engine speed signal, which is input from ECM.
FUEL METER [lit.]	X	X	Displays the value, which processes a resistance signal from fuel gauge.
W TEMP METER [°C] or [°F]	X	X	Displays the value of engine coolant temperature signal, which is input from ECM.
ABS W/L [ON/OFF]		X	Displays [ON/OFF] condition of ABS warning lamp.
VDC/TCS IND [ON/OFF]		X	Displays [ON/OFF] condition of VDC OFF indicator lamp.
SLIP IND [ON/OFF]		X	Displays [ON/OFF] condition of SLIP indicator lamp.
BRAKE W/L [ON/OFF]		X	Displays [ON/OFF] condition of brake warning lamp.*
DOOR W/L [ON/OFF]		X	Displays [ON/OFF] condition of door warning lamp.
TRUNK W/L [ON/OFF]		X	This item is not used for this model. "OFF" is always displayed.
HI-BEAM IND [ON/OFF]		X	Displays [ON/OFF] condition of high beam indicator.
TURN IND [ON/OFF]		X	Displays [ON/OFF] condition of turn indicator.
OIL W/L [ON/OFF]		X	Displays [ON/OFF] condition of oil pressure warning lamp.
C-ENG W/L [ON/OFF]		X	Displays [ON/OFF] condition of malfunction indicator lamp.
CRUISE IND [ON/OFF]		X	Displays [ON/OFF] condition of CRUISE indicator.
SET IND [ON/OFF]		X	Displays [ON/OFF] condition of SET indicator.
AT CHECK W/L [ON/OFF]		X	Displays [ON/OFF] condition of AT CHECK warning lamp.
AIR PRES W/L [ON/OFF]		X	Displays [ON/OFF] condition of tire pressure warning lamp.
KEY G/Y W/L [ON/OFF]		X	This item is not used for this model. "OFF" is always displayed.
KEY R W/L [ON/OFF]		X	This item is not used for this model. "OFF" is always displayed.
KEY KNOB W/L [ON/OFF]		X	This item is not used for this model. "OFF" is always displayed.
M RANGE SW [ON/OFF]	X	X	Displays [ON/OFF] condition of manual mode range switch.
NM RANGE SW [ON/OFF]	X	X	Displays [ON/OFF] condition of except for manual mode range switch.
AT SFT UP SW [ON/OFF]	X	X	Displays [ON/OFF] condition of A/T shift-up switch.
AT SFT DWN SW [ON/OFF]	X	X	Displays [ON/OFF] condition of A/T shift-down switch.
DISTANCE [km] or [mile]	X	X	Displays the value, which is calculated by vehicle speed signal, fuel gauge and fuel consumption from ECM.
BUZZER [ON/OFF]	X	X	Displays [ON/OFF] condition of buzzer.
BRAKE SW [ON/OFF]		X	Indicates [ON/OFF] condition of parking brake switch.
AT-M GEAR [1, 2, 3, 4, 5]	X	X	Indicates [1, 2, 3, 4, 5] condition of A/T manual mode gear position.
P RANGE IND [ON/OFF]	X	X	Indicates [ON/OFF] condition of A/T shift P range indicator.
R RANGE IND [ON/OFF]	X	X	Indicates [ON/OFF] condition of A/T shift R range indicator.
N RANGE IND [ON/OFF]	X	X	Indicates [ON/OFF] condition of A/T shift N range indicator.
D RANGE IND [ON/OFF]	X	X	Indicates [ON/OFF] condition of A/T shift D range indicator.
4 RANGE IND [ON/OFF]	X	X	Indicates [ON/OFF] condition of A/T shift 4 range indicator.
3 RANGE IND [ON/OFF]	X	X	Indicates [ON/OFF] condition of A/T shift 3 range indicator.

## DIAGNOSIS SYSTEM (METER)

### < FUNCTION DIAGNOSIS >

Display item [Unit]	MAIN SIGNALS	SELECTION FROM MENU	Description
2 RANGE IND [ON/OFF]	X	X	Indicates [ON/OFF] condition of A/T shift 2 range indicator.
1 RANGE IND [ON/OFF]	X	X	Indicates [ON/OFF] condition of A/T shift 1range indicator.
CRUISE W/L [ON/OFF]		X	Indicates [ON/OFF] condition of CRUISE warning lamp.
4WD LOCK SW [ON/OFF]		X	Indicates [ON/OFF] condition of 4WD lock switch.
4WD LOCK IND [ON/OFF]		X	Indicates [ON/OFF] condition of 4WD lock indicator.
SEAT BELT W/L [ON/OFF]		X	Indicates [ON/OFF] condition of seat belt warning lamp.

**NOTE:**

Some items are not available due to vehicle specification.

\*: The monitor will indicate "OFF" even though the brake warning lamp is on if either of the following conditions exist.

- The parking brake is engaged
- The brake fluid level is low

# DTC U1000 CAN COMMUNICATION

< COMPONENT DIAGNOSIS >

## COMPONENT DIAGNOSIS

### DTC U1000 CAN COMMUNICATION

#### DTC Logic

INFOID:000000003790439

#### DTC DETECTION LOGIC

DTC	CONSULT-III display	Detection condition
U1000	CAN COMM CIRC [U1000]	When combination meter is not receiving CAN communication signals for 2 seconds or more.

#### Diagnosis Procedure

INFOID:000000003790440

Symptom: Displays "CAN COMM CIRC [U1000]" as a self-diagnosis result of combination meter.

#### 1. CHECK CAN COMMUNICATION

Select "SELF-DIAG RESULTS" mode for "METER/M&A" with CONSULT-III.

>> Go to "LAN system". Refer to [LAN-14. "Trouble Diagnosis Flow Chart"](#).

A  
B  
C  
D  
E  
F  
G  
H  
I  
J  
K  
L  
M  
O  
P

MWI

# DTC B2205 VEHICLE SPEED CIRCUIT

< COMPONENT DIAGNOSIS >

## DTC B2205 VEHICLE SPEED CIRCUIT

### Description

INFOID:000000003790441

The ABS actuator and electric unit (control unit) provides a vehicle speed signal to the combination meter via CAN communication lines.

### DTC Logic

INFOID:000000003790442

DTC	CONSULT-III display	Detection condition
B2205	VEHICLE SPEED CIRC [B2205]	Malfunction is detected when an erroneous speed signal is received for 2 seconds or more.

### Diagnosis Procedure

INFOID:000000003790443

Symptom: Displays "VEHICLE SPEED CIRC [B2205]" as a self-diagnosis result of combination meter.

#### 1. CHECK COMBINATION METER INPUT SIGNAL

1. Start engine and select "METER/M&A" on CONSULT-III.
2. Using "SPEED METER" on "DATA MONITOR", compare the value of DATA MONITOR with speedometer pointer of combination meter. Speedometer and DATA MONITOR indications should be close.

Is the inspection result normal?

- YES >> Perform ABS actuator and electric unit (control unit) self-diagnosis.
- ABS: [BRC-16, "CONSULT-III Function \(ABS\)"](#)
  - ABL/ABS: [BRC-78, "CONSULT-III Function \(ABS\)"](#)
  - VDC/TCS/ABS: [BRC-164, "CONSULT-III Function \(ABS\)"](#)
- NO >> Replace combination meter. Refer to [MWI-103, "Removal and Installation"](#).



# POWER SUPPLY AND GROUND CIRCUIT

< COMPONENT DIAGNOSIS >

## POWER SUPPLY AND GROUND CIRCUIT COMBINATION METER

### COMBINATION METER : Diagnosis Procedure

INFOID:000000003790444

#### 1. CHECK FUSES

Check for blown combination meter fuses.

Unit	Power source	Fuse No.
Combination meter	Battery	3
	Ignition switch ON or START	14
	Ignition switch ACC or ON	4

Is the inspection result normal?

YES >> GO TO 2

NO >> If fuse is blown, be sure to eliminate cause of malfunction before installing new fuse.

#### 2. POWER SUPPLY CIRCUIT CHECK

1. Disconnect combination meter connector M24.
2. Check voltage between combination meter harness connector M24 terminals 1, 8, 24 and ground.

Terminals		(-)	Ignition switch position			
(+)	Connector		Terminal	OFF	ACC	ON
M24	1	Ground	0V	Battery voltage	Battery voltage	0V
	8		Battery voltage	Battery voltage	Battery voltage	Battery voltage
	24		0V	0V	Battery voltage	Battery voltage

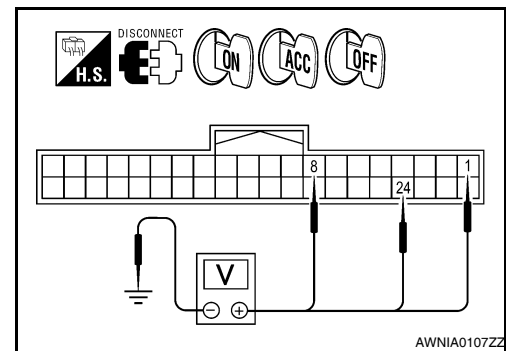

Is the inspection result normal?

YES >> GO TO 3

NO >> Check harness for open between combination meter and fuse.

#### 3. GROUND CIRCUIT CHECK

1. Turn ignition switch OFF.
2. Disconnect combination meter connector M25.
3. Check continuity between combination meter harness connector M25 terminal 52 and ground, and connector M24 terminal 9 and ground.

Terminals		(-)	Continuity
(+)	Connector		
A: M25	52	Ground	Yes
B: M24	9		

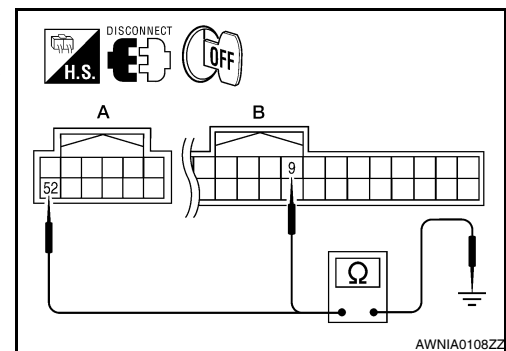

Is the inspection result normal?

YES >> Inspection End.

NO >> Check ground harness.

### BCM (BODY CONTROL MODULE)

# POWER SUPPLY AND GROUND CIRCUIT

< COMPONENT DIAGNOSIS >

## BCM (BODY CONTROL MODULE) : Diagnosis Procedure

INFOID:000000004215413

### 1. CHECK FUSES AND FUSIBLE LINK

Check that the following fuses and fusible link are not blown.

Terminal No.	Signal name	Fuses and fusible link No.
57	Battery power supply	22 (15A)
70		F (50A)
11	Ignition ACC or ON	4 (10A)
38	Ignition ON or START	59 (10A)

Is the fuse blown?

YES >> Replace the blown fuse or fusible link after repairing the affected circuit.

NO >> GO TO 2

### 2. CHECK POWER SUPPLY CIRCUIT

1. Turn ignition switch OFF.
2. Disconnect BCM.
3. Check voltage between BCM harness connector and ground.

Connector	Terminals		Power source	Condition	Voltage (V) (Approx.)
	(+)	(-)			
M18	11	Ground	ACC power supply	Ignition switch ACC or ON	Battery voltage
	38	Ground	Ignition power supply	Ignition switch ON or START	Battery voltage
M20	57	Ground	Battery power supply	Ignition switch OFF	Battery voltage
	70	Ground	Battery power supply	Ignition switch OFF	Battery voltage

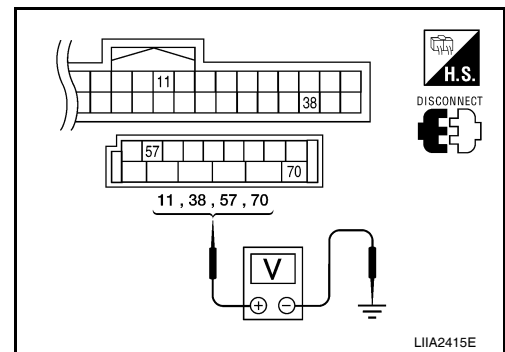

Is the measurement value normal?

YES >> GO TO 3

NO >> Repair or replace harness.

### 3. CHECK GROUND CIRCUIT

Check continuity between BCM harness connector and ground.

BCM		Ground	Continuity
Connector	Terminal		
M20	67		Yes

Does continuity exist?

YES >> Inspection End.

NO >> Repair or replace harness.

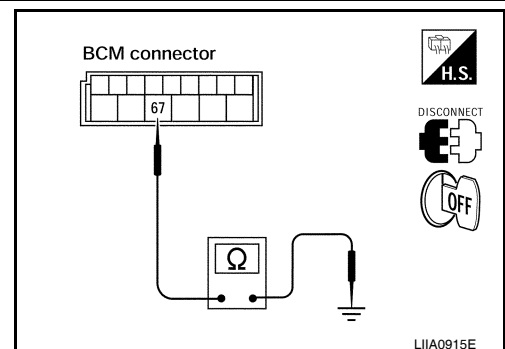

IPDM E/R (INTELLIGENT POWER DISTRIBUTION MODULE ENGINE ROOM)

IPDM E/R (INTELLIGENT POWER DISTRIBUTION MODULE ENGINE ROOM) : Di-

# POWER SUPPLY AND GROUND CIRCUIT

< COMPONENT DIAGNOSIS >

## agnosis Procedure

INFOID:00000004215414

### 1. CHECK FUSES AND FUSIBLE LINK

Check that the following IPDM E/R fuses or fusible link are not blown.

Terminal No.	Signal name	Fuses and fusible link No.
1	Battery	A (140A), D (80A)
2	Battery	C (80A)
12	Ignition switch ON or START	59 (10A)

Is the fuse blown?

- YES >> Replace the blown fuse or fusible link after repairing the affected circuit.  
 NO >> GO TO 2

### 2. CHECK BATTERY POWER SUPPLY CIRCUIT

- Turn ignition switch OFF.
- Disconnect IPDM E/R.
- Check voltage between IPDM E/R harness connectors and ground.

Terminals		Ignition switch position	Ignition switch position		
(+)	(-)		OFF	ON	START
Connector	Terminal	Ground	OFF	ON	START
	E118 (A)		1	Battery voltage	Battery voltage
	2		Battery voltage	Battery voltage	Battery voltage
E119 (B)	12		0V	Battery voltage	Battery voltage

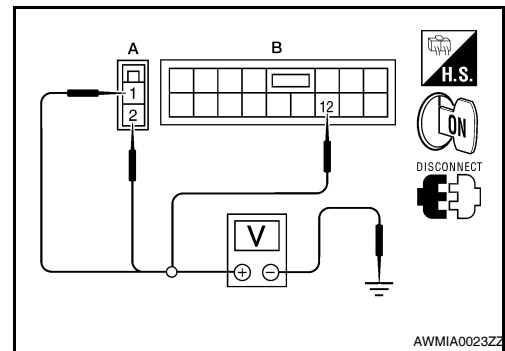

Is the measurement value normal?

- YES >> GO TO 3  
 NO >> Repair or replace harness.

### 3. CHECK GROUND CIRCUIT

- Turn ignition switch OFF.
- Check continuity between IPDM E/R harness connectors and ground.

IPDM E/R		Ground	Continuity
Connector	Terminal		Continuity
E122 (A)	38	Ground	Yes
E124 (B)	59		

Does continuity exist?

- YES >> Inspection End.  
 NO >> Repair or replace harness.

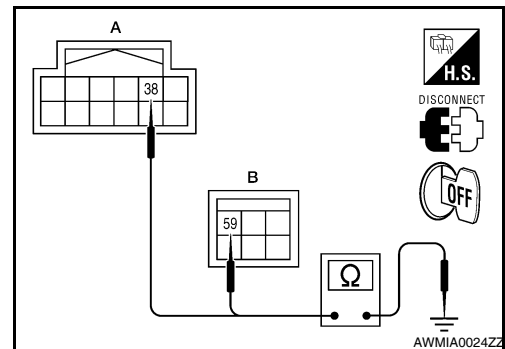

A  
B  
C  
D  
E  
F  
G  
H  
I  
J  
K  
L  
M  
N  
O  
P

MWI

# FUEL LEVEL SENSOR SIGNAL CIRCUIT

< COMPONENT DIAGNOSIS >

## FUEL LEVEL SENSOR SIGNAL CIRCUIT

### Description

INFOID:000000003790447

The fuel level sensor unit and fuel pump detects the approximate fuel level in the fuel tank and transmits the fuel level signal to the combination meter.

### Component Function Check

INFOID:000000003790448

#### 1.COMBINATION METER INPUT SIGNAL

1. Select "METER/M&A" on CONSULT-III.
2. Using "FUEL METER" of "DATA MONITOR", compare the value of DATA MONITOR with fuel gauge pointer of combination meter.

Fuel gauge pointer	Reference value of data monitor [lit.]	
	Short wheelbase models (SWB)	Long wheelbase models (LWB)
Full	Approx. 93	Approx. 122
3/4	Approx. 73	Approx. 97
1/2	Approx. 52	Approx. 68
1/4	Approx. 30	Approx. 40
Empty	Approx. 11	Approx. 15

#### NOTE:

For model identification, refer to [GI-19. "Model Variation"](#).

Does the data monitor value approximately match the fuel gauge indication?

YES >> Inspection End.

NO >> Replace combination meter. Refer to [MWI-103. "Removal and Installation"](#).

### Diagnosis Procedure

INFOID:000000003790449

#### 1.CHECK HARNESS CONNECTOR

1. Turn ignition switch OFF.
2. Check combination meter and fuel level sensor unit terminals (meter-side and harness-side) for poor connection.

Is the inspection result normal?

YES >> GO TO 2

NO >> Repair or replace terminals or connectors.

#### 2.CHECK FUEL LEVEL SENSOR UNIT CIRCUIT

1. Disconnect combination meter connector and fuel level sensor unit connector.
2. Check continuity between combination meter harness connector (B) and fuel level sensor unit and fuel pump harness connector (A).

A		B		Continuity
Connector	Terminal	Connector	Terminal	
C7 (with Flexible Fuel) C5 (without Flexible Fuel)	2	M24	15	Yes

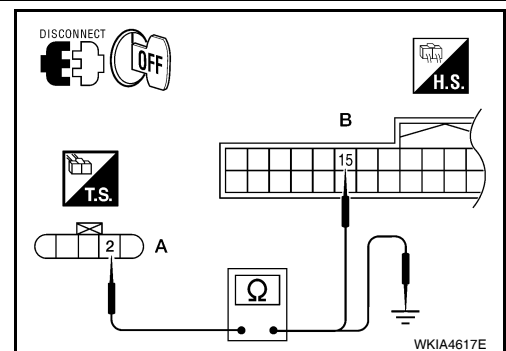

3. Check continuity between fuel level sensor unit and fuel pump harness connector (A) and ground.

# FUEL LEVEL SENSOR SIGNAL CIRCUIT

## < COMPONENT DIAGNOSIS >

A		Ground	Continuity
Connector	Terminal		
C7 (with Flexible Fuel) C5 (without Flexible Fuel)	2		No

Is the inspection result normal?

YES >> GO TO 3

NO >> Repair harness or connector.

### 3. CHECK FUEL LEVEL SENSOR UNIT GROUND CIRCUIT

1. Check continuity between combination meter harness connector (B) and fuel level sensor unit and fuel pump harness connector (A).

A		B		Continuity
Connector	Terminal	Connector	Terminal	
C7 (with Flexible Fuel) C5 (without Flexible Fuel)	5	M24	16	Yes

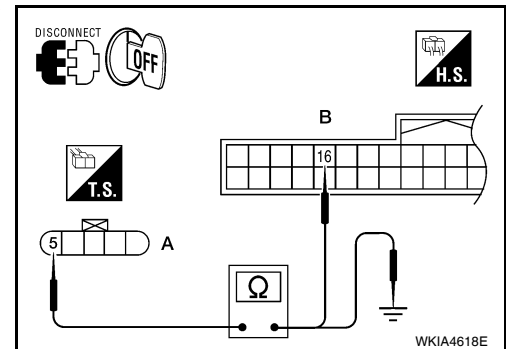

2. Check continuity between fuel level sensor unit and fuel pump harness connector (A) and ground.

A		Ground	Continuity
Connector	Terminal		
C7 (with Flexible Fuel) C5 (without Flexible Fuel)	5		No

Is the inspection result normal?

YES >> GO TO 4

NO >> Repair harness or connector.

### 4. CHECK INSTALLATION CONDITION

Check fuel level sensor unit installation, and check whether the float arm interferes or binds with any of the internal components in the fuel tank.

Is the inspection result normal?

YES >> Inspection End.

NO >> Install the fuel level sensor unit properly.

### Component Inspection

INFOID:000000003790450

#### 1. REMOVE FUEL LEVEL SENSOR UNIT

Remove the fuel level sensor unit. Refer to [FL-12. "Removal and Installation"](#).

>> GO TO 2

#### 2. CHECK FUEL LEVEL SENSOR UNIT AND FUEL PUMP

A  
B  
C  
D  
E  
F  
G  
H  
I  
J  
K  
L  
M  
O  
P

## FUEL LEVEL SENSOR SIGNAL CIRCUIT

### < COMPONENT DIAGNOSIS >

Check the resistance between terminals 2 and 5.

Terminal		Float position mm (in)		Resistance value (Approx.)
2	5	*1	Empty	7.5 (0.3)
		*2	Full	218.9 (8.6)

\*1 and \*2: When float arm is in contact with stopper.

#### Is inspection result normal?

YES >> Inspection End.

NO >> Replace fuel level sensor unit and fuel pump. Refer to [FL-12, "Removal and Installation"](#).

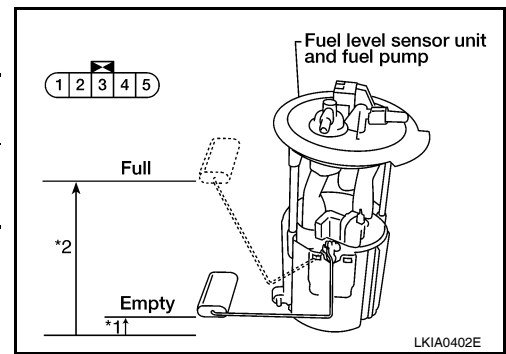

# OIL PRESSURE SWITCH SIGNAL CIRCUIT

< COMPONENT DIAGNOSIS >

## OIL PRESSURE SWITCH SIGNAL CIRCUIT

### Description

INFOID:000000003790451

Detects the engine oil pressure and transmits the oil pressure switch signal to the IPDM E/R.

### Component Function Check

INFOID:000000003790452

#### 1.COMBINATION METER INPUT SIGNAL

1. Select "METER/M&A" on CONSULT-III.
2. Monitor "OIL W/L" of "DATA MONITOR" while operating ignition switch.

#### OIL W/L

When ignition switch is in ON : ON  
position (Engine stopped)

When engine is running : OFF

>> Inspection End.

### Diagnosis Procedure

INFOID:000000003790453

#### 1.CHECK OIL PRESSURE SWITCH CIRCUIT

1. Turn ignition switch OFF.
2. Disconnect IPDM E/R connector E122 and oil pressure switch connector F4.
3. Check continuity between IPDM E/R harness connector E122 (A) terminal 42 and oil pressure switch harness connector F4 (B) terminal 1.

Continuity should exist.

Is the inspection result normal?

- YES >> Inspection End.  
NO >> Repair harness or connector.

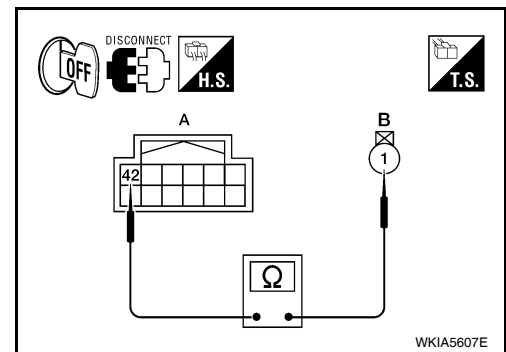

### Component Inspection

INFOID:000000003790454

#### 1.CHECK OIL PRESSURE SWITCH

Check continuity between oil pressure switch and ground.

Condition	Oil pressure [kPa (kg/cm <sup>2</sup> , psi)]	Continuity
Engine stopped	Less than 29 (0.3, 4)	Yes
Engine running	More than 29 (0.3, 4)	No

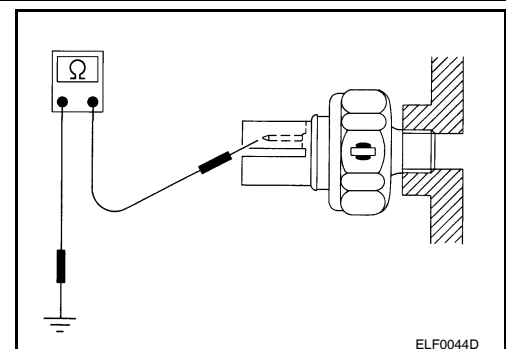

Is the inspection result normal?

- YES >> Inspection End.  
NO >> Replace the oil pressure switch.

# PARKING BRAKE SWITCH SIGNAL CIRCUIT

< COMPONENT DIAGNOSIS >

## PARKING BRAKE SWITCH SIGNAL CIRCUIT

### Description

INFOID:000000003790455

Transmits the parking brake switch signal to the combination meter.

### Component Function Check

INFOID:000000003790456

#### 1.COMBINATION METER INPUT SIGNAL

1. Start engine.
2. Monitor "BRAKE" warning lamp while applying and releasing the parking brake.

**BRAKE warning lamp**

**Parking brake applied : ON**

**Parking brake released : OFF**

>> Inspection End.

### Diagnosis Procedure

INFOID:000000003790457

#### 1.CHECK PARKING BRAKE SWITCH CIRCUIT

1. Disconnect combination meter connector and parking brake switch connector.
2. Check continuity between combination meter harness connector M24 (A) terminal 23 and parking brake switch harness connector M11 (B) terminal 1.

**23 - 1 : Continuity should exist.**

3. Check continuity between combination meter harness connector M24 (A) terminal 23 and ground.

**23 - Ground : Continuity should not exist.**

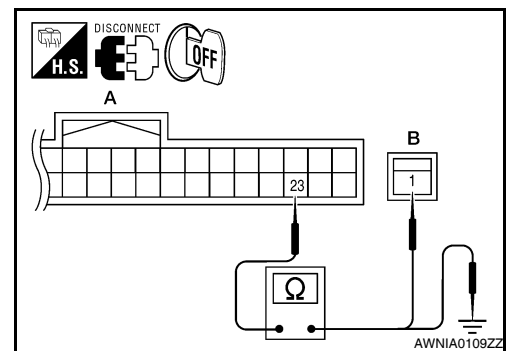

Is the inspection result normal?

- YES >> Inspection End.  
NO >> Repair harness or connector.

### Component Inspection

INFOID:000000003790458

#### 1.CHECK PARKING BRAKE SWITCH

Check continuity between parking brake switch terminal 1 and switch case ground.

Component	Terminal	Condition	Continuity
Parking brake switch	1	Parking brake applied	Yes
		Parking brake released	No

Is the inspection result normal?

- YES >> Inspection End.  
NO >> Replace parking brake switch.

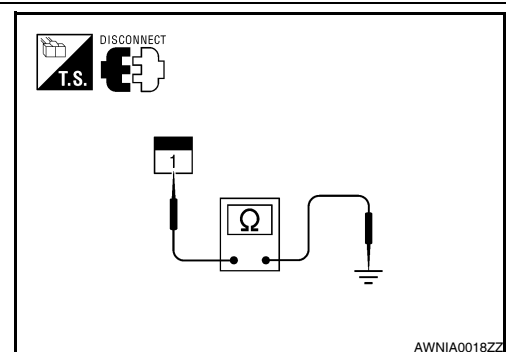



# WASHER LEVEL SWITCH SIGNAL CIRCUIT

< COMPONENT DIAGNOSIS >

## WASHER LEVEL SWITCH SIGNAL CIRCUIT

### Description

INFOID:000000003790459

Transmits the washer level switch signal to the combination meter.

### Diagnosis Procedure

INFOID:000000003790460

#### 1. CHECK WASHER FLUID LEVEL SWITCH SIGNAL CIRCUIT

1. Turn ignition switch OFF.
2. Disconnect combination meter connector and washer fluid level switch connector.
3. Check continuity between combination meter harness connector M24 (A) terminal 37 and washer fluid level switch harness connector E106 (B) terminal 1.

**37 - 1 : Continuity should exist.**

4. Check continuity between combination meter harness connector M24 (A) terminal 37 and ground.

**37 - Ground : Continuity should not exist.**

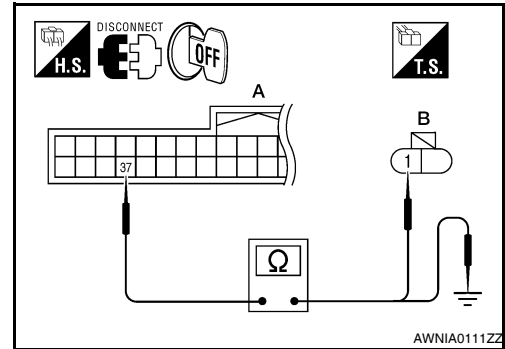

Is the inspection result normal?

YES >> GO TO 2

NO >> Repair harness or connector.

#### 2. CHECK WASHER FLUID LEVEL SWITCH GROUND CIRCUIT

Check continuity between washer fluid level switch harness connector E106 terminal 2 and ground.

**2 - Ground : Continuity should exist.**

Is the inspection result normal?

YES >> Inspection End.

NO >> Repair harness or connector.

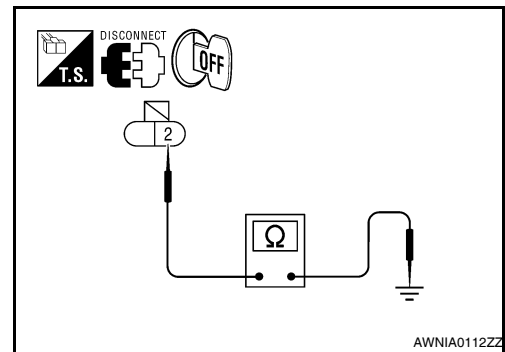

### Component Inspection

INFOID:000000003790461

#### 1. CHECK WASHER FLUID LEVEL SWITCH

Check continuity between washer fluid level switch terminals 1 and 2.

Terminal	Washer fluid level	Continuity
1 - 2	Low	Yes
	Other	No

Is the inspection result normal?

YES >> Inspection End.

NO >> Replace washer fluid level switch.

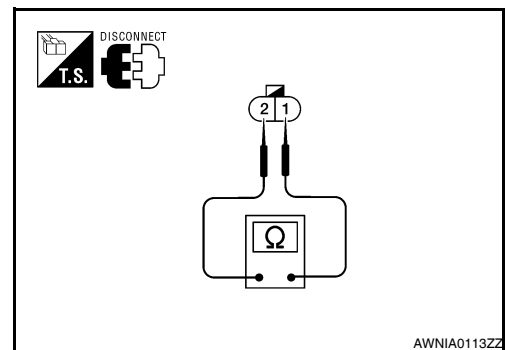

A  
B  
C  
D  
E  
F  
G  
H  
I  
J  
K  
L  
M  
N  
O  
P

MWI

# COMPASS

< COMPONENT DIAGNOSIS >

## COMPASS

Wiring Diagram - With HomeLink® Universal Transceiver -

INFOID:000000004244597

### COMPASS - WITH HOMELINK UNIVERSAL TRANSCEIVER

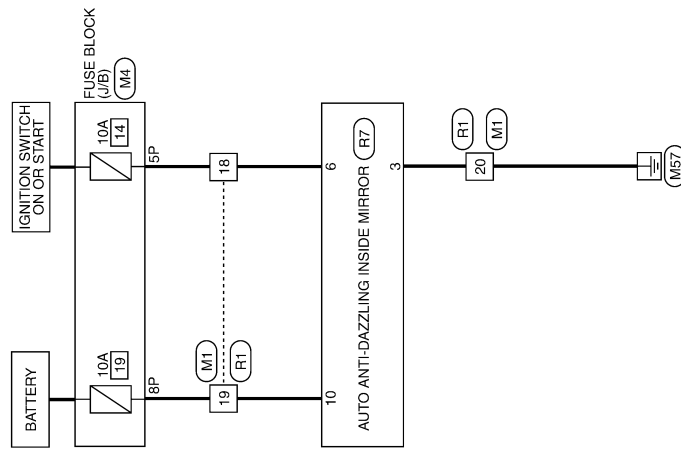

AWNWA0034G

## COMPASS CONNECTORS - WITH HOMELINK UNIVERSAL TRANSCIEVER

Connector No.	M1
Connector Name	WIRE TO WIRE
Connector Color	WHITE

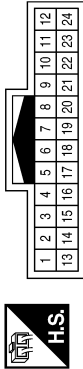

Terminal No.	Color of Wire	Signal Name
18	W/G	-
19	R/Y	-
20	B	-

Connector No.	M4
Connector Name	FUSE BLOCK (J/B)
Connector Color	WHITE



Terminal No.	Color of Wire	Signal Name
5P	W/G	-
8P	R/Y	-

Connector No.	R1
Connector Name	WIRE TO WIRE
Connector Color	WHITE

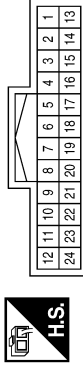

Terminal No.	Color of Wire	Signal Name
18	W/G	-
19	R/Y	-
20	B	-

Connector No.	R7
Connector Name	AUTO ANTI-DAZZLING INSIDE MIRROR
Connector Color	BLACK

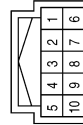

Terminal No.	Color of Wire	Signal Name
3	B	GND
6	W/G	IGN
10	R/Y	B

AWNIA0391GB

# COMPASS

< COMPONENT DIAGNOSIS >

## Wiring Diagram - Without HomeLink® Universal Transceiver -

INFOID:000000004244598

### COMPASS - WITHOUT HOMELINK UNIVERSAL TRANSCEIVER

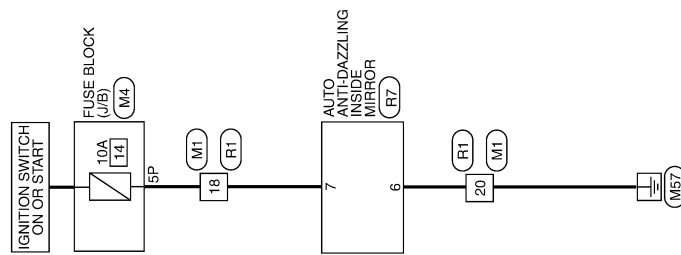

AWNWA0035G

## COMPASS CONNECTORS - WITHOUT HOMELINK UNIVERSAL TRANSCEIVER

Connector No.	M1
Connector Name	WIRE TO WIRE
Connector Color	WHITE

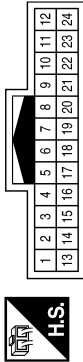

Terminal No.	Color of Wire	Signal Name
18	W/G	-
20	B	-

Connector No.	M4
Connector Name	FUSE BLOCK (J/B)
Connector Color	WHITE

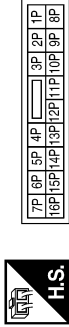

Terminal No.	Color of Wire	Signal Name
5P	W/G	-

Connector No.	R1
Connector Name	WIRE TO WIRE
Connector Color	WHITE

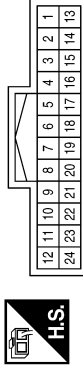

Terminal No.	Color of Wire	Signal Name
18	W/G	-
20	B	-

Connector No.	R7
Connector Name	AUTO ANTI-DAZZLING INSIDE MIRROR
Connector Color	RED

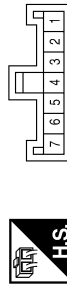

Terminal No.	Color of Wire	Signal Name
6	B	GND
7	W/G	IGN

A  
B  
C  
D  
E  
F  
G  
H  
I  
J  
K  
L  
M  
MWI  
O  
P

AWNIA0392GB

# COMBINATION METER

< ECU DIAGNOSIS >

## ECU DIAGNOSIS

### COMBINATION METER

Reference Value

INFOID:000000003790463

#### TERMINAL LAYOUT

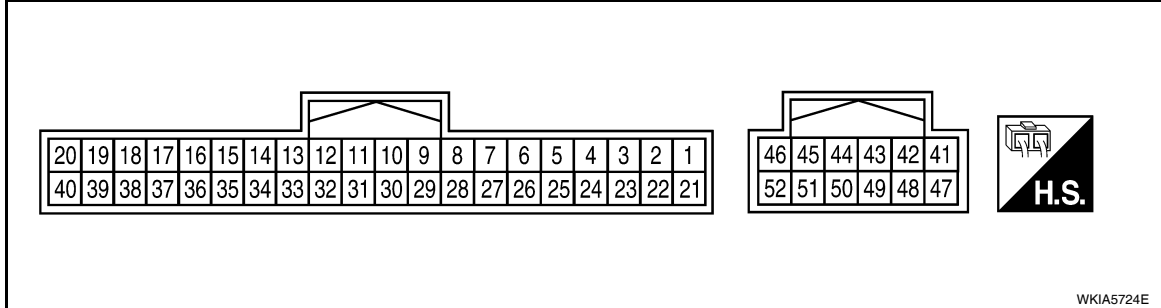

#### PHYSICAL VALUES

Terminal	Wire color	Item	Condition		Reference value (V) (Approx.)
			Ignition switch	Operation or condition	
1	O	Ignition switch ACC or ON	—	—	Battery voltage
2	P	Air bag warning lamp input	ON	Air bag warning lamp ON	4
				Air bag warning lamp OFF	0
8	Y/R <sup>*1</sup>	Battery power supply	—	—	Battery voltage
8	P <sup>*2</sup>	Battery power supply	—	—	Battery voltage
9	B	Ground	—	—	0
11	L	CAN-H	—	—	—
12	P	CAN-L	—	—	—
14	L	DIFF LOCK indicator input	ON	DIFF LOCK indicator ON	0
				DIFF LOCK indicator OFF	Battery voltage
15	Y/L	Fuel level sensor signal	—	—	Refer to <a href="#">MWI-12. "FUEL GAUGE : System Description"</a> .
16	B/P	Fuel level sensor ground	ON	—	0
17	R/G	Stop lamp switch	—	Brake pedal depressed	Battery voltage
				Brake pedal released	0
18	P/B	Brake fluid level switch	ON	Brake fluid level low	0
				Brake fluid level normal	Battery voltage
23	G	Parking brake switch	ON	Parking brake applied	0
				Parking brake released	Battery voltage
24	O/L	Ignition switch ON or START	ON	—	Battery voltage
27	O/B	Seat belt buckle switch LH	ON	Unfastened (ON)	0
				Fastened (OFF)	Battery voltage
28	G/O	Security indicator input	OFF	Security indicator ON	0
				Security indicator OFF	Battery voltage

# COMBINATION METER

## < ECU DIAGNOSIS >

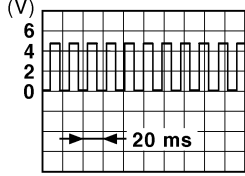
Terminal	Wire color	Item	Condition		Reference value (V) (Approx.)
			Ignition switch	Operation or condition	
29	W/R	Vehicle speed signal output (8-pulse)	ON	Speedometer operated [When vehicle speed is approx. 40 km/h (25 MPH)]	<b>NOTE:</b> Maximum voltage may be 12V due to specifications (connected units).  <small>PKIC0643E</small>
37	W/L	Washer fluid level switch	ON	Washer fluid level low	0
				Washer fluid level normal	Battery voltage
41	P/L	Seat belt buckle switch RH	ON	Unfastened (ON)	0
				Fastened (OFF)	Battery voltage
45	BR/W	Generator	ON	Generator voltage low	0
				Generator voltage normal	Battery voltage
50	BR	Illumination output	—	—	Refer to <a href="#">INL-10, "System Description"</a> .
52	B	Ground	—	—	0

**NOTE:**

\*1: With Type A main harness. For definition of Type A main harness, refer to [PG-38, "Harness Layout"](#).

\*2: With Type B main harness. For definition of Type B main harness, refer to [PG-38, "Harness Layout"](#).

A  
B  
C  
D  
E  
F  
G  
H  
I  
J  
K  
L  
M  
N  
O  
P

MWI

# COMBINATION METER

< ECU DIAGNOSIS >

## Wiring Diagram

INFOID:000000003790464

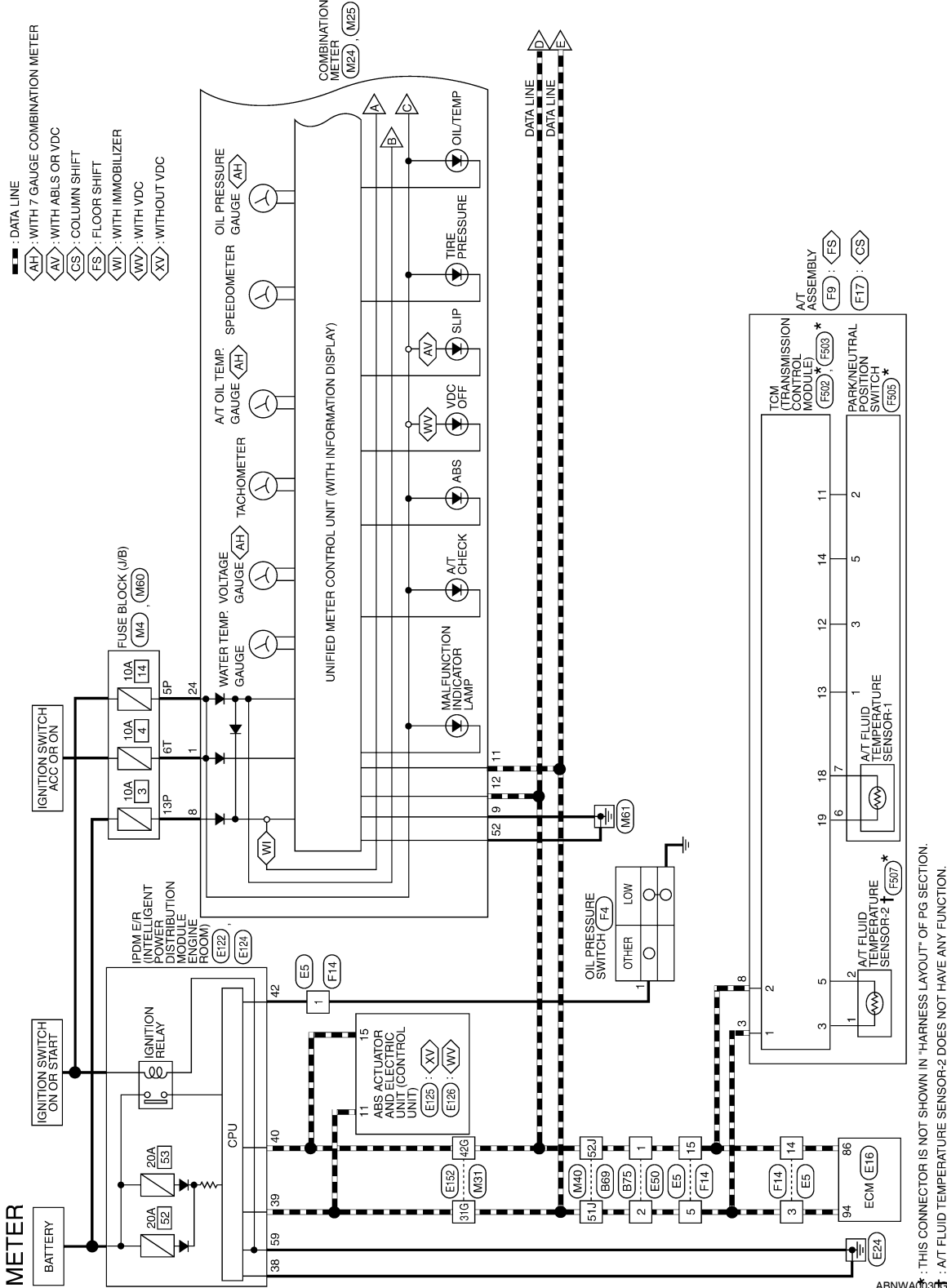

\* : THIS CONNECTOR IS NOT SHOWN IN "HARNESS LAYOUT" OF PG SECTION.  
 \* : AT FLUID TEMPERATURE SENSOR-2 DOES NOT HAVE ANY FUNCTION.

ABNWA0301



# COMBINATION METER

< ECU DIAGNOSIS >

- CC : CREW CAB
- KC : KING CAB
- WI : WITH IMMOBILIZER
- : DATA LINE

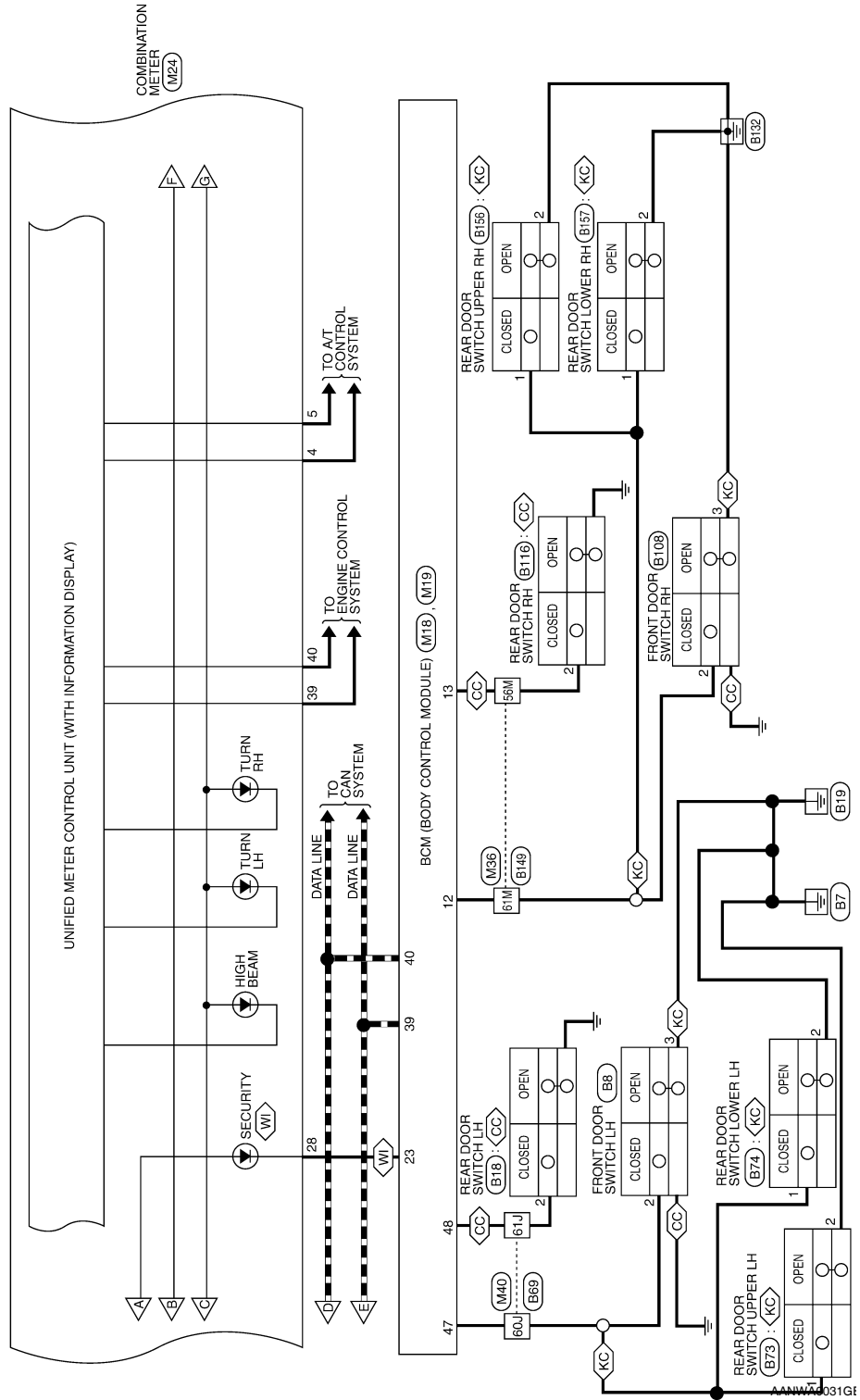

A  
B  
C  
D  
E  
F  
G  
H  
I  
J  
K  
L  
M  
N  
O  
P

MWI

# COMBINATION METER

< ECU DIAGNOSIS >

- : WITH 4-WHEEL DRIVE
- : COLUMN SHIFT
- : WITH ELECTRONIC LOCKING REAR DIFFERENTIAL
- : WITH FLEXIBLE FUEL
- : WITHOUT FLEXIBLE FUEL

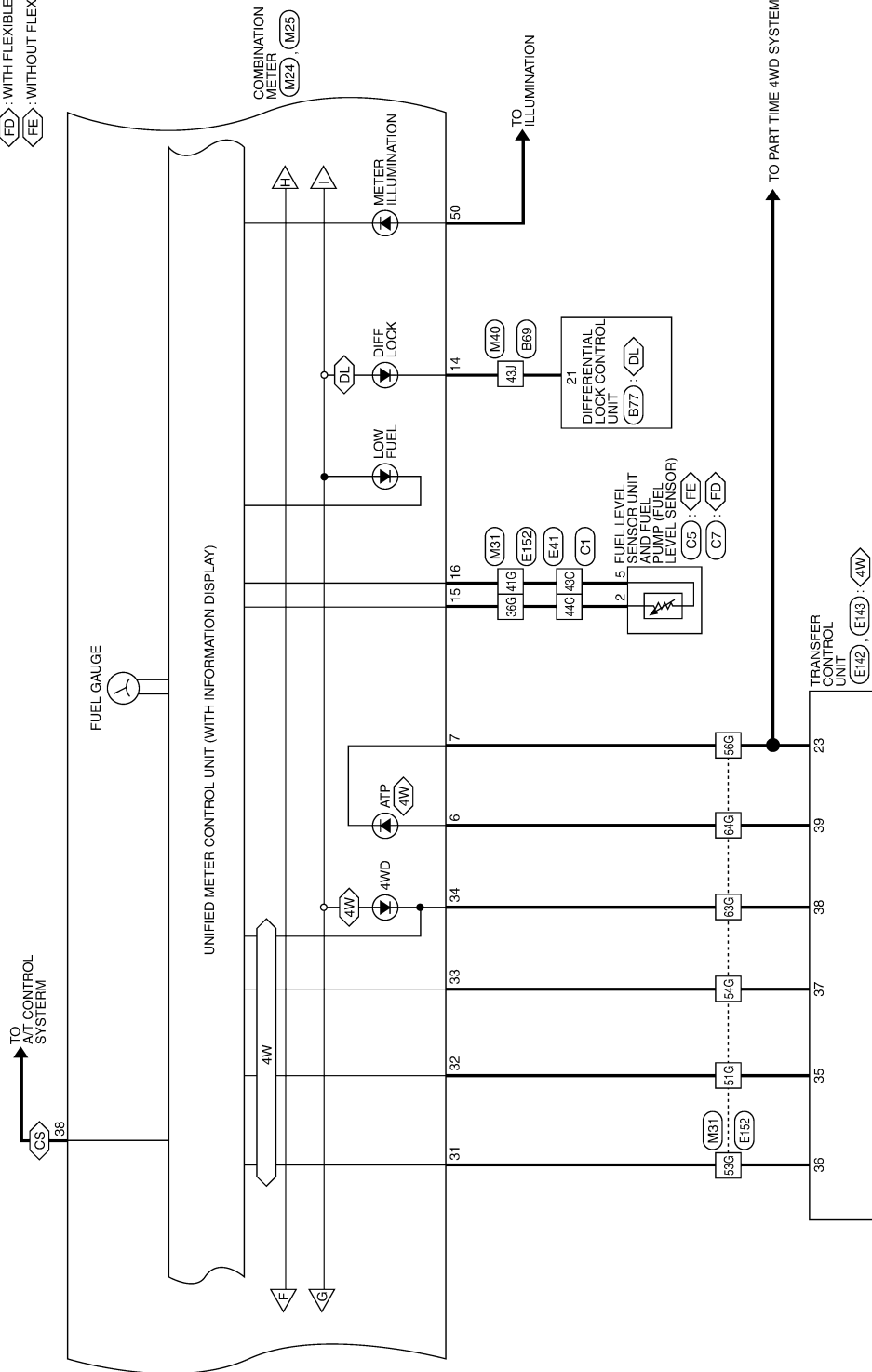

ABNWA0031G1

# COMBINATION METER

< ECU DIAGNOSIS >

T7 : TRAILER TOW 7 PIN

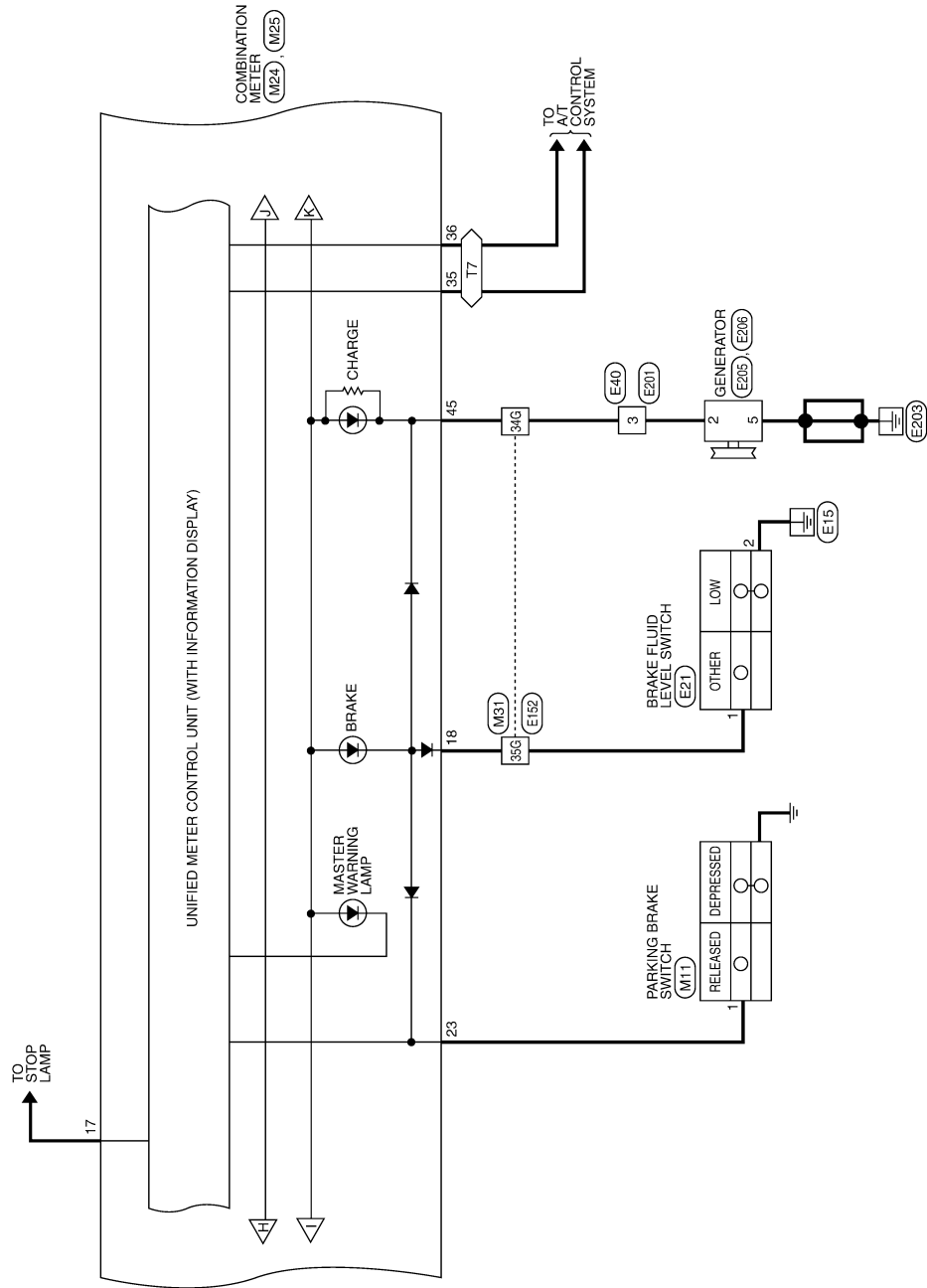

A  
B  
C  
D  
E  
F  
G  
H  
I  
J  
K  
L  
M  
N  
O  
P

MWI

ABNWA0032Gf

# COMBINATION METER

< ECU DIAGNOSIS >

FS : FLOOR SHIFT  
 ML : WITH MID OR PREMIUM AUDIO SYSTEM

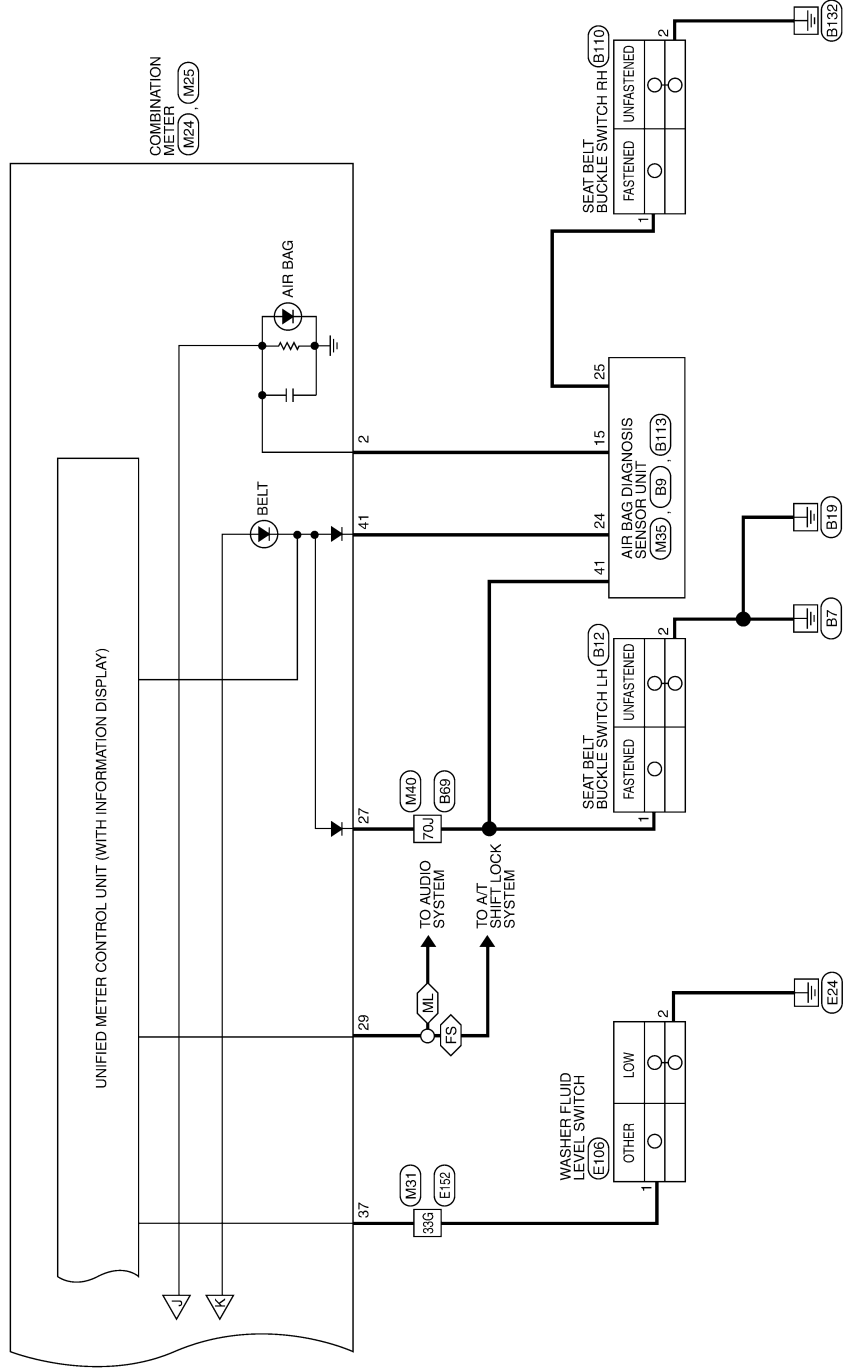

AANWA0032GI

## METER CONNECTORS

Connector No.	M4
Connector Name	FUSE BLOCK (J/B)
Connector Color	WHITE



Terminal No.	Color of Wire	Signal Name
5P	O/L	-
13P	P	-

Connector No.	M11
Connector Name	PARKING BRAKE SWITCH
Connector Color	BLACK



Terminal No.	Color of Wire	Signal Name
1	G	-

Connector No.	M18
Connector Name	BCM (BODY CONTROL MODULE)
Connector Color	WHITE

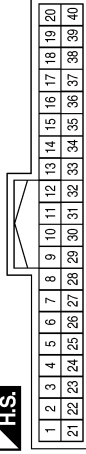

Terminal No.	Color of Wire	Signal Name
12	R/L	DOOR SW (AS)
13	GR	DOOR SW (RR)
23	G/O	SECURITY INDICATOR OUTPUT
39	L	CAN-H
40	P	CAN-L

Connector No.	M19
Connector Name	BCM (BODY CONTROL MODULE)
Connector Color	WHITE

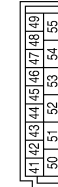

Terminal No.	Color of Wire	Signal Name
47	SB	DOOR SW (DR)
48	R/Y	DOOR SW (RL)

A  
B  
C  
D  
E  
F  
G  
H  
I  
J  
K  
L  
M  
MWI  
O  
P

# COMBINATION METER

< ECU DIAGNOSIS >

Connector No.	M24
Connector Name	COMBINATION METER
Connector Color	WHITE

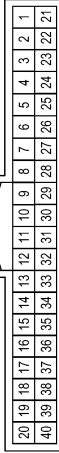

Terminal No.	Color of Wire	Signal Name
1	O	ACCESSORY
2	P	AIR BAG
3	-	-
4	Y/G	AT 1 RANGE DN
5	SB	AT 4 RANGE UP
6	L/B	ATP+
7	R/B	ATP-
8	Y/R	BATTERY (TYPE A*)
8	P	BATTERY (TYPE B*)
9	B	GND

Connector No.	M25
Connector Name	COMBINATION METER
Connector Color	WHITE

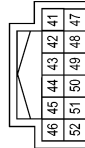

Terminal No.	Color of Wire	Signal Name
41	P/L	PASS SEAT BELT
42	-	-
43	-	-
44	-	-

Terminal No.	Color of Wire	Signal Name
28	G/O	SECURITY
29	W/R	SPEED OUT
30	-	-
31	L	TF LOCK
32	B/W	TF 2WD
33	W/G	TF 4LO
34	W/B	TF 4WD
35	LG/R	TOW MODE
36	Y/V	TOW MODE LAMP
37	W/L	WASHER FLUID
38	V/W	MANUAL MODE
39	B/R	PN ATCU
40	GR/R	PN REVERSE

Terminal No.	Color of Wire	Signal Name
10	-	-
11	L	CAN-H
12	P	CAN-L
13	-	-
14	L	DIFF LOCK
15	Y/L	FUEL IN
16	B/P	ANALOG GND
17	R/G	BRAKE PEDAL
18	P/B	BRAKE FLUID
19	-	-
20	-	-
21	-	-
22	-	-
23	G	PARK BRAKE
24	O/L	RUN START
25	-	-
26	-	-
27	O/B	SEATBELT

Terminal No.	Color of Wire	Signal Name
45	BR/W	CHARGE IN
46	-	-
47	-	-
48	-	-
49	-	-
50	BR	ILL LED CON OUTPUT
51	-	-
52	B	ILL GND

\*\* : REFER TO HARNESS LAYOUT OF PG SECTION FOR DEFINITION OF TYPE A AND TYPE B.

ABNIA0066GB

# COMBINATION METER

< ECU DIAGNOSIS >

Connector No.	M35
Connector Name	AIR BAG DIAGNOSIS SENSOR UNIT
Connector Color	YELLOW

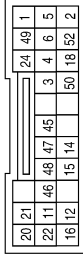

Terminal No.	Color of Wire	Signal Name
15	P	WARN LAMP
24	P/L	SEATBELT MINDER

Terminal No.	Color of Wire	Signal Name
31G	L	-
33G	W/L	-
34G	BR/W	-
35G	P/B	-
36G	Y/L	-
41G	B/P	-
42G	P	-
51G	B/W	-
53G	L	-
54G	W/G	-
56G	R/B	-
63G	W/B	-
64G	L/B	-

Connector No.	M31
Connector Name	WIRE TO WIRE
Connector Color	WHITE

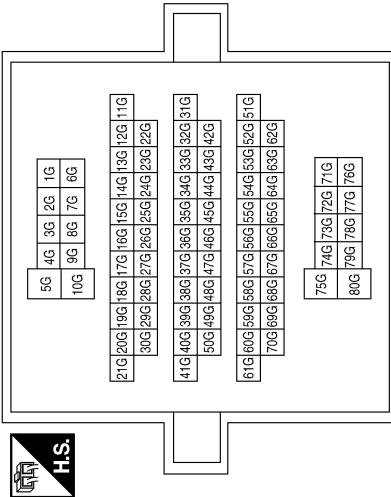

Terminal No.	Color of Wire	Signal Name
56M	GR	-
61M	R/L	-

Connector No.	M36
Connector Name	WIRE TO WIRE
Connector Color	WHITE

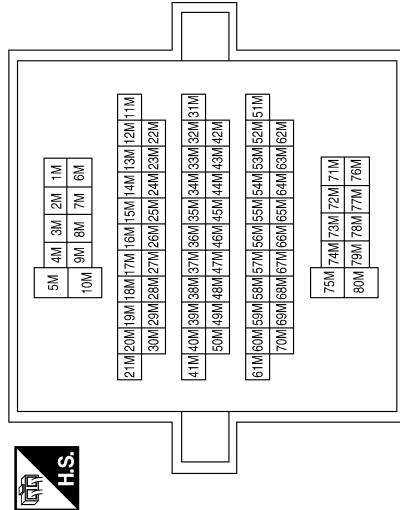

ABNIA0067GB

A  
B  
C  
D  
E  
F  
G  
H  
I  
J  
K  
L  
M  
N  
O  
P

# COMBINATION METER

< ECU DIAGNOSIS >

Connector No.	M40
Connector Name	WIRE TO WIRE
Connector Color	WHITE

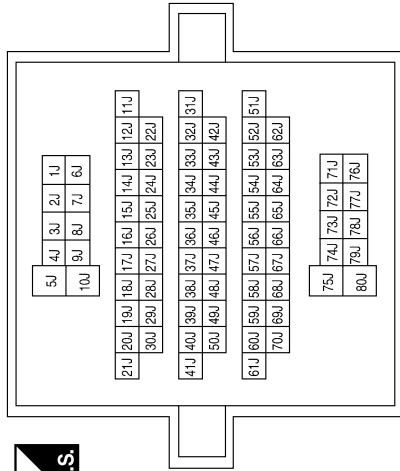

Terminal No.	Color of Wire	Signal Name
43J	L	-
51J	L	-
52J	P	-
60J	SB	-
61J	R/Y	-
70J	O/B	-

Connector No.	M60
Connector Name	FUSE BLOCK (J/B)
Connector Color	WHITE

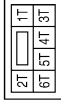

Terminal No.	Color of Wire	Signal Name
6T	O	-

Connector No.	E5
Connector Name	WIRE TO WIRE
Connector Color	WHITE

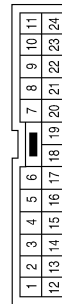

Terminal No.	Color of Wire	Signal Name
1	GR	-
3	L	-
5	L	-
14	P	-
15	P	-

Connector No.	E16
Connector Name	ECM
Connector Color	BLACK

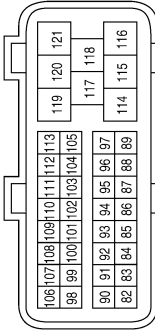

Terminal No.	Color of Wire	Signal Name
86	P	CAN-L
94	L	CAN-H

Connector No.	E21
Connector Name	BRAKE FLUID LEVEL SWITCH
Connector Color	GRAY



Terminal No.	Color of Wire	Signal Name
1	P/B	-
2	B	-

ABNIA0068GB



# COMBINATION METER

< ECU DIAGNOSIS >

Connector No.	E40
Connector Name	WIRE TO WIRE
Connector Color	BLACK



Terminal No.	Color of Wire	Signal Name
3	BR/W	-

Connector No.	E41
Connector Name	WIRE TO WIRE
Connector Color	GRAY

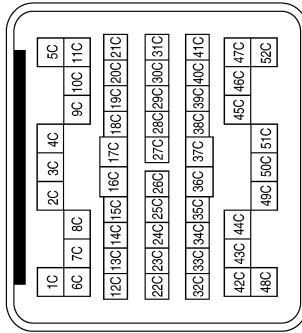

Terminal No.	Color of Wire	Signal Name
43C	B/P	-
44C	Y/L	-

Connector No.	E50
Connector Name	WIRE TO WIRE
Connector Color	BROWN



Terminal No.	Color of Wire	Signal Name
1	P	-
2	L	-

Connector No.	E106
Connector Name	WASHER FLUID LEVEL SWITCH
Connector Color	BROWN

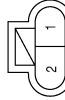

Terminal No.	Color of Wire	Signal Name
1	W/L	-
2	B	-

Connector No.	E122
Connector Name	IPDM E/R (INTELLIGENT POWER DISTRIBUTION MODULE ENGINE ROOM)
Connector Color	WHITE

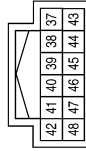

Terminal No.	Color of Wire	Signal Name
38	B	GND (SIGNAL)
39	L	CAN-H
40	P	CAN-L
42	GR	OIL PRESSURE SW

Connector No.	E124
Connector Name	IPDM E/R (INTELLIGENT POWER DISTRIBUTION MODULE ENGINE ROOM)
Connector Color	BLACK



Terminal No.	Color of Wire	Signal Name
59	B	GND (POWER)

ABNIA0069GB

A  
B  
C  
D  
E  
F  
G  
H  
I  
J  
K  
L  
M  
N  
O  
P

# COMBINATION METER

< ECU DIAGNOSIS >

Connector No.	E142
Connector Name	TRANSFER CONTROL UNIT
Connector Color	WHITE

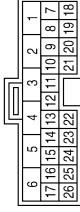

Terminal No.	Color of Wire	Signal Name
23	R/B	ATP SW

Connector No.	E126
Connector Name	ABS ACTUATOR AND ELECTRIC UNIT (CONTROL UNIT) (WITH VDC)
Connector Color	BLACK

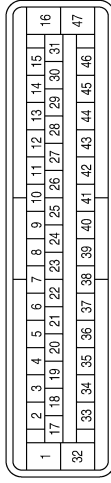

Terminal No.	Color of Wire	Signal Name
11	L	CAN-H
15	P	CAN-L

Connector No.	E125
Connector Name	ABS ACTUATOR AND ELECTRIC UNIT (CONTROL UNIT) (WITHOUT VDC)
Connector Color	BLACK

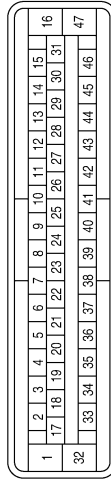

Terminal No.	Color of Wire	Signal Name
11	L	CAN-H
15	P	CAN-L

Terminal No.	Color of Wire	Signal Name
31G	L	-
33G	W/L	-
34G	BR/W	-
35G	P/B	-
36G	Y/L	-
41G	B/P	-
42G	P	-
51G	B/W	-
53G	L	-
54G	W/G	-
56G	R/B	-
63G	W/B	-
64G	L/B	-

Connector No.	E152
Connector Name	WIRE TO WIRE
Connector Color	WHITE

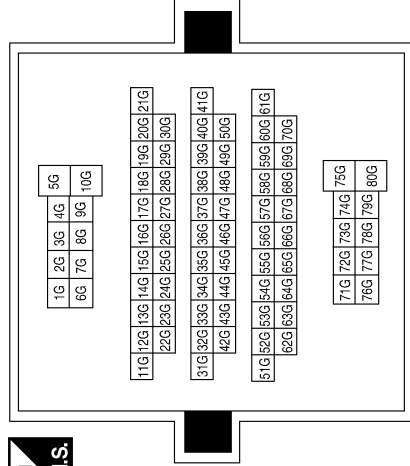

Connector No.	E143
Connector Name	TRANSFER CONTROL UNIT
Connector Color	WHITE

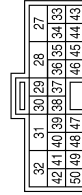

Terminal No.	Color of Wire	Signal Name
35	B/W	2WD IND
36	L	LOCK IND
37	W/G	4LD IND
38	W/B	4WD FAIL
39	L/B	ATP IND

ABNIA0070GB

# COMBINATION METER

< ECU DIAGNOSIS >

Connector No.	E201
Connector Name	WIRE TO WIRE
Connector Color	BLACK



Terminal No.	3	Color of Wire	BR/W	Signal Name	-
--------------	---	---------------	------	-------------	---

Connector No.	E205
Connector Name	GENERATOR
Connector Color	BLACK



Terminal No.	2	Color of Wire	BR/W	Signal Name	-
--------------	---	---------------	------	-------------	---

Connector No.	E206
Connector Name	GENERATOR
Connector Color	-

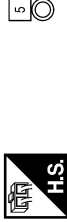

Terminal No.	5	Color of Wire	B	Signal Name	-
--------------	---	---------------	---	-------------	---

Connector No.	F4
Connector Name	OIL PRESSURE SWITCH
Connector Color	GRAY



Terminal No.	1	Color of Wire	GR	Signal Name	-
--------------	---	---------------	----	-------------	---

Connector No.	F9
Connector Name	A/T ASSEMBLY (FLOOR SHIFT)
Connector Color	GREEN



Terminal No.	3	Color of Wire	L	Signal Name	-
Terminal No.	8	Color of Wire	P	Signal Name	-

Connector No.	F14
Connector Name	WIRE TO WIRE
Connector Color	WHITE

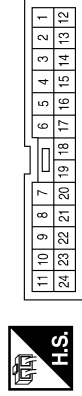

Terminal No.	1	Color of Wire	GR	Signal Name	-
Terminal No.	3	Color of Wire	L	Signal Name	-
Terminal No.	5	Color of Wire	L	Signal Name	-
Terminal No.	14	Color of Wire	P	Signal Name	-
Terminal No.	15	Color of Wire	P	Signal Name	-

A  
B  
C  
D  
E  
F  
G  
H  
I  
J  
K  
L  
M  
N  
O  
P

MWI

ABNIA0071GB

# COMBINATION METER

< ECU DIAGNOSIS >

Connector No.	F17
Connector Name	A/T ASSEMBLY (COLUMN SHIFT)
Connector Color	GREEN

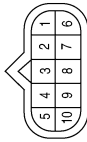

Terminal No.	Color of Wire	Signal Name
3	L	-
8	P	-

Connector No.	F502
Connector Name	TCM (TRANSMISSION CONTROL MODULE)
Connector Color	GRAY

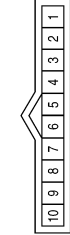

Terminal No.	Color of Wire	Signal Name
1	B/R	CAN-H
2	L/Y	CAN-L
3	W/Y	ATF SENS 2-
5	W/R	ATF SENS 2+

Connector No.	F503
Connector Name	TCM (TRANSMISSION CONTROL MODULE)
Connector Color	GREEN



Terminal No.	Color of Wire	Signal Name
11	W	INH-SW4
12	GR	INH-SW2
13	BR	INH-SW1
14	L	INH-SW3
18	O	ATF SENS 1-
19	G	ATF SENS 1+

Connector No.	F505
Connector Name	PARK/NEUTRAL POSITION SWITCH
Connector Color	GRAY

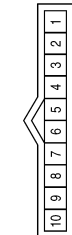

Terminal No.	Color of Wire	Signal Name
1	BR	S1
2	W	S4
3	GR	S2
5	L	S3
6	G	-
7	O	-

Connector No.	F507
Connector Name	A/T FLUID TEMPERATURE SENSOR-2
Connector Color	WHITE



Terminal No.	Color of Wire	Signal Name
1	W/Y	-
2	W/R	-

Connector No.	C1
Connector Name	WIRE TO WIRE
Connector Color	GRAY

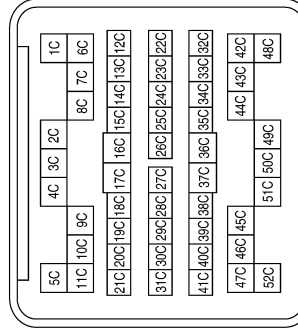

Terminal No.	Color of Wire	Signal Name
43C	B/P	-
44C	Y/L	-

ABNIA0072GB

# COMBINATION METER

< ECU DIAGNOSIS >

Connector No.	B8
Connector Name	FRONT DOOR SWITCH LH
Connector Color	WHITE

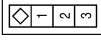

Terminal No.	Color of Wire	Signal Name
2	SB	-
3	B	-

Connector No.	C7
Connector Name	FUEL LEVEL SENSOR UNIT AND FUEL PUMP (WITH FLEXIBLE FUEL)
Connector Color	GRAY

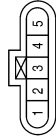

Terminal No.	Color of Wire	Signal Name
2	Y/L	-
5	B/P	-

Connector No.	C5
Connector Name	FUEL LEVEL SENSOR UNIT AND FUEL PUMP (WITHOUT FLEXIBLE FUEL)
Connector Color	GRAY

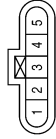

Terminal No.	Color of Wire	Signal Name
2	Y/L	-
5	B/P	-

Connector No.	B18
Connector Name	REAR DOOR SWITCH LH
Connector Color	WHITE

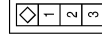

Terminal No.	Color of Wire	Signal Name
2	R/Y	-

Connector No.	B12
Connector Name	SEAT BUCKLE SWITCH LH
Connector Color	WHITE

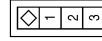

Terminal No.	Color of Wire	Signal Name
1	O/B	-
2	B	-

Connector No.	B9
Connector Name	AIR BAG DIAGNOSIS SENSOR UNIT
Connector Color	YELLOW

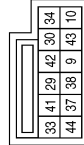

Terminal No.	Color of Wire	Signal Name
41	O/B	BUCKLE SW LH

ABNIA0073GB

A  
B  
C  
D  
E  
F  
G  
H  
I  
J  
K  
L  
M  
O  
P

# COMBINATION METER

< ECU DIAGNOSIS >

Connector No.	B69
Connector Name	WIRE TO WIRE
Connector Color	WHITE

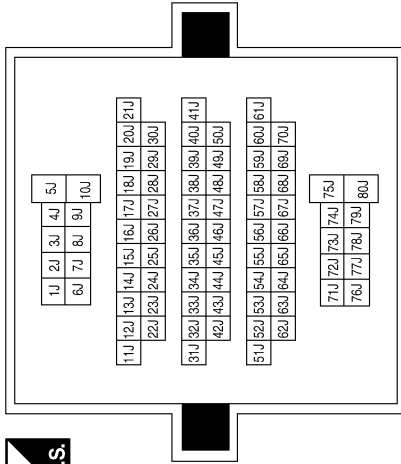

Terminal No.	Color of Wire	Signal Name
43J	L	-
51J	L	-
52J	P	-
60J	SB	-
61J	R/Y	-
70J	O/B	-

Connector No.	B73
Connector Name	REAR DOOR SWITCH UPPER LH
Connector Color	BLACK



Terminal No.	Color of Wire	Signal Name
1	SB	-
2	B	-

Connector No.	B74
Connector Name	REAR DOOR SWITCH LOWER LH
Connector Color	BLACK



Connector No.	B75
Connector Name	WIRE TO WIRE
Connector Color	BROWN



Terminal No.	Color of Wire	Signal Name
1	SB	-
2	B	-

Connector No.	B77
Connector Name	DIFFERENTIAL LOCK CONTROL UNIT
Connector Color	WHITE



Terminal No.	Color of Wire	Signal Name
21	L	IND

ABNIA0074GB

# COMBINATION METER

< ECU DIAGNOSIS >

Connector No.	B113
Connector Name	AIR BAG DIAGNOSIS SENSOR UNIT
Connector Color	YELLOW

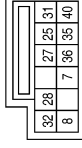

Terminal No.	25	Color of Wire	L	Signal Name	BUCKLE SW RH
--------------	----	---------------	---	-------------	--------------

Connector No.	B110
Connector Name	SEAT BELT BUCKLE SWITCH RH
Connector Color	WHITE



Terminal No.	1	Color of Wire	L	Signal Name	-
2	B	-	-	-	-

Connector No.	B108
Connector Name	FRONT DOOR SWITCH RH
Connector Color	WHITE

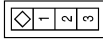

Terminal No.	2	Color of Wire	R/L	Signal Name	-
3	B	-	-	-	-

Terminal No.	56M	Color of Wire	GR	Signal Name	-
61M	R/L	-	-	-	-

Connector No.	B149
Connector Name	WIRE TO WIRE
Connector Color	WHITE

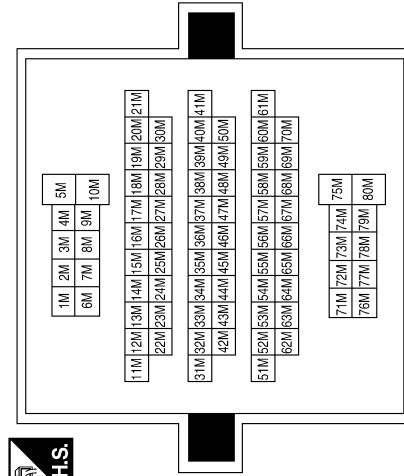

Connector No.	B116
Connector Name	REAR DOOR SWITCH RH
Connector Color	WHITE



Terminal No.	2	Color of Wire	GR	Signal Name	-
--------------	---	---------------	----	-------------	---

ABNIA0075GB

A  
B  
C  
D  
E  
F  
G  
H  
I  
J  
K  
L  
M  
N  
O  
P

# COMBINATION METER

< ECU DIAGNOSIS >

Connector No.	B157
Connector Name	REAR DOOR SWITCH LOWER RH
Connector Color	BLACK



Terminal No.	Color of Wire	Signal Name
1	R/L	-
2	B	-

Connector No.	B156
Connector Name	REAR DOOR SWITCH UPPER RH
Connector Color	BLACK



Terminal No.	Color of Wire	Signal Name
1	R/L	-
2	B	-

ABNIA0076GB

INFOID:000000003790465

## Fail Safe

The combination meter performs a fail-safe operation for the functions listed below when communication is lost.



# COMBINATION METER

## < ECU DIAGNOSIS >

	Function	Specifications		
	Speedometer	Zero indication.	A	
	Tachometer		B	
	Fuel gauge		C	
	Engine coolant temperature gauge		D	
	Engine oil pressure gauge (if equipped)			
	Voltage gauge (if equipped)			
	A/T oil temperature gauge (if equipped)			
	Illumination control	Meter illumination	Change to nighttime mode when communication is lost.	D
	Segment LCD	Odometer	Freeze current indication.	E
		A/T position	Display turns off.	
	Buzzer		Buzzer turns off.	
Warning lamp/indicator lamp	ABS warning lamp	Lamp turns on when communication is lost.		F
	Brake warning lamp			
	VDC OFF indicator lamp			
	SLIP indicator lamp			
	A/T CHECK warning lamp	Lamp turns off when communication is lost.		G
	Oil pressure/coolant temperature warning lamp			
	Malfunction indicator lamp			
	Master warning lamp			
	Air bag warning lamp			
	High beam indicator			
	Turn signal indicator lamp			
	Driver and passenger seat belt warning lamp			
	Charge warning lamp	Lamp turns off when disconnected.		J
	Security indicator lamp			
	4WD indicator lamp			
	ATP indicator lamp			
DIFF LOCK indicator lamp				
Low tire pressure warning lamp	Lamp will flash every second for 1 minute and then stay on continuously thereafter.		K	

## DTC Index

INFOID:000000003790466

MWI

CONSULT-III display	Malfunction	Reference page
CAN COMM CIRC [U1000]	Malfunction is detected in CAN communication. <b>CAUTION:</b> Even when there is no malfunction on CAN communication system, malfunction may be misinterpreted when battery has low voltage (when maintaining 7 - 8 V for about 2 seconds) or 10A fuse [No. 3, located in the fuse block (J/B)] is disconnected.	<a href="#">MWI-31</a>
VEHICLE SPEED CIRC [B2205]	Malfunction is detected when an erroneous speed signal is input. <b>CAUTION:</b> Even when there is no malfunction on speed signal system, malfunction may be misinterpreted when battery has low voltage (when maintaining 7 - 8 V for about 2 seconds).	<a href="#">MWI-32</a>

**NOTE:**

“TIME” indicates the following.

## COMBINATION METER

### < ECU DIAGNOSIS >

---

- 0: Indicates that a malfunction is detected at present.
- 1-63: Indicates that a malfunction was detected in the past. (Displays number of ignition switch OFF → ON cycles after malfunction is detected. Self-diagnosis result is erased when "63" is exceeded.)

# BCM (BODY CONTROL MODULE)

< ECU DIAGNOSIS >

## BCM (BODY CONTROL MODULE)

Reference Value

INFOID:000000004215466

VALUES ON THE DIAGNOSIS TOOL

Monitor Item	Condition	Value/Status
AIR COND SW	A/C switch OFF	OFF
	A/C switch ON	ON
AUT LIGHT SYS	Outside of the room is dark	OFF
	Outside of the room is bright	ON
AUTO LIGHT SW	Lighting switch OFF	OFF
	Lighting switch AUTO	ON
CDL LOCK SW	Door lock/unlock switch does not operate	OFF
	Press door lock/unlock switch to the LOCK side	ON
CDL UNLOCK SW	Door lock/unlock switch does not operate	OFF
	Press door lock/unlock switch to the UNLOCK side	ON
DOOR SW-AS	Front door RH closed	OFF
	Front door RH opened	ON
DOOR SW-DR	Front door LH closed	OFF
	Front door LH opened	ON
DOOR SW-RL	Rear door LH closed	OFF
	Rear door LH opened	ON
DOOR SW-RR	Rear door RH closed	OFF
	Rear door RH opened	ON
ENGINE RUN	Engine stopped	OFF
	Engine running	ON
FR FOG SW	Front fog lamp switch OFF	OFF
	Front fog lamp switch ON	ON
FR WASHER SW	Front washer switch OFF	OFF
	Front washer switch ON	ON
FR WIPER LOW	Front wiper switch OFF	OFF
	Front wiper switch LO	ON
FR WIPER HI	Front wiper switch OFF	OFF
	Front wiper switch HI	ON
FR WIPER INT	Front wiper switch OFF	OFF
	Front wiper switch INT	ON
FR WIPER STOP	Any position other than front wiper stop position	OFF
	Front wiper stop position	ON
HAZARD SW	When hazard switch is not pressed	OFF
	When hazard switch is pressed	ON
LIGHT SW 1ST	Lighting switch OFF	OFF
	Lighting switch 1st	ON
HEADLAMP SW1	Headlamp switch OFF	OFF
	Headlamp switch 1st	ON

A

B

C

D

E

F

G

H

I

J

K

L

M

MWI

O

P

## BCM (BODY CONTROL MODULE)

### < ECU DIAGNOSIS >

Monitor Item	Condition	Value/Status
HEADLAMP SW2	Headlamp switch OFF	OFF
	Headlamp switch 1st	ON
HI BEAM SW	High beam switch OFF	OFF
	High beam switch HI	ON
H/L WASH SW	<b>NOTE:</b> The item is indicated, but not monitored	OFF
IGN ON SW	Ignition switch OFF or ACC	OFF
	Ignition switch ON	ON
IGN SW CAN	Ignition switch OFF or ACC	OFF
	Ignition switch ON	ON
INT VOLUME	Wiper intermittent dial is in a dial position 1 - 7	1 - 7
KEY ON SW	Key is removed from key cylinder	OFF
	Key is inserted to key cylinder	ON
KEYLESS LOCK	LOCK button of key fob is not pressed	OFF
	LOCK button of key fob is pressed	ON
KEYLESS UNLOCK	UNLOCK button of key fob is not pressed	OFF
	UNLOCK button of key fob is pressed	ON
OIL PRESS SW	<ul style="list-style-type: none"> <li>• Ignition switch OFF or ACC</li> <li>• Engine running</li> </ul>	OFF
	Ignition switch ON	ON
PASSING SW	Other than lighting switch PASS	OFF
	Lighting switch PASS	ON
REAR DEF SW	Rear window defogger switch OFF	OFF
	Rear window defogger switch ON	ON
RKE LOCK AND UN-LOCK	<b>NOTE:</b> The item is indicated, but not monitored	OFF
		ON
TAIL LAMP SW	Lighting switch OFF	OFF
	Lighting switch 1ST	ON
TURN SIGNAL L	Turn signal switch OFF	OFF
	Turn signal switch LH	ON
TURN SIGNAL R	Turn signal switch OFF	OFF
	Turn signal switch RH	ON
VEHICLE SPEED	While driving	Equivalent to speedometer reading

# BCM (BODY CONTROL MODULE)

< ECU DIAGNOSIS >

## Terminal Layout

INFOID:000000004215467

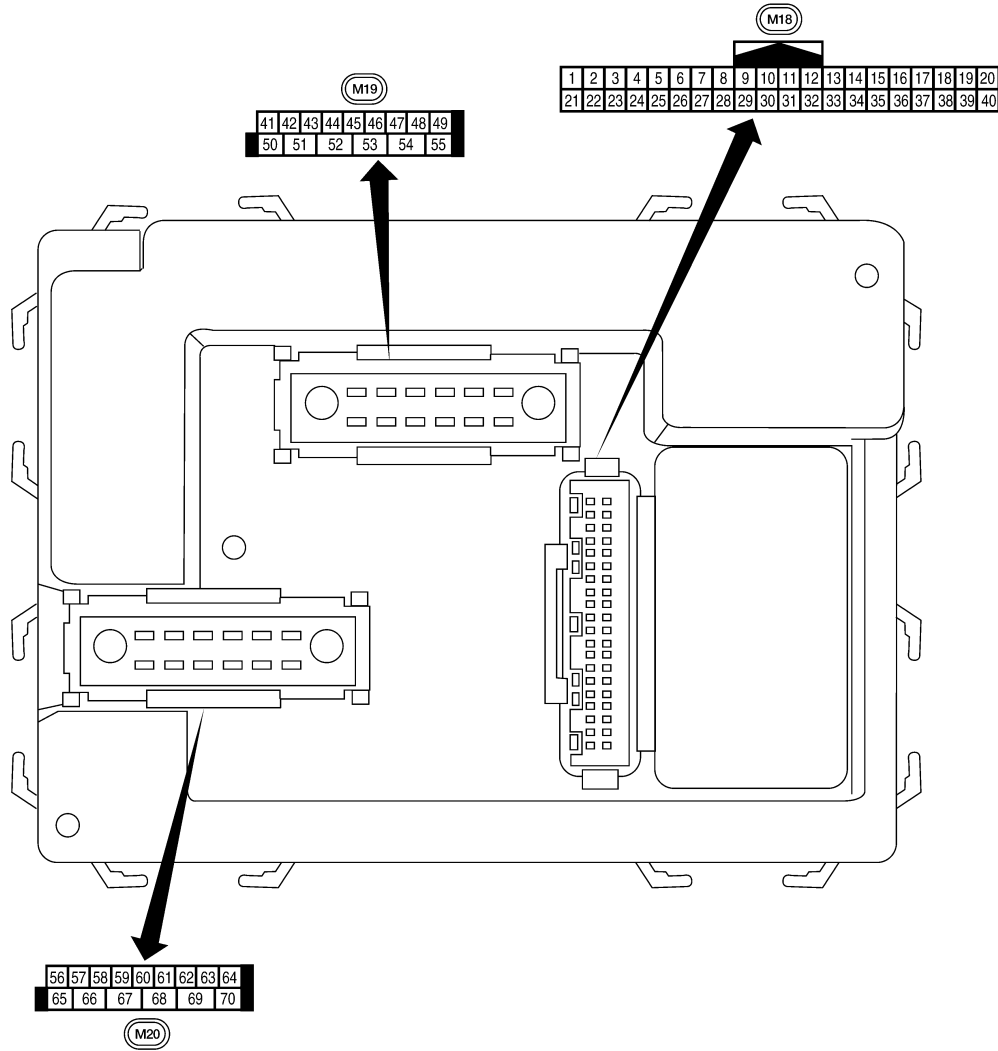

A  
B  
C  
D  
E  
F  
G  
H  
I  
J  
K  
L  
M

MWI



Physical Values

LIA2443E

INFOID:000000004215468

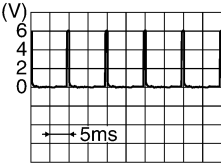

# BCM (BODY CONTROL MODULE)

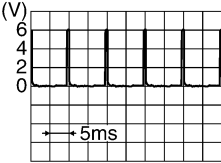
## < ECU DIAGNOSIS >

Terminal	Wire color	Signal name	Signal input/output	Measuring condition		Reference value or waveform (Approx.)
				Ignition switch	Operation or condition	
1	BR/W	Ignition keyhole illumination	Output	OFF	Door is locked (SW OFF)	Battery voltage
					Door is unlocked (SW OFF)	0V
2	SB	Combination switch input 5	Input	ON	Lighting, turn, wiper OFF Wiper dial position 4	 SKIA5291E
3	G/Y	Combination switch input 4	Input	ON	Lighting, turn, wiper OFF Wiper dial position 4	 SKIA5292E
4	Y	Combination switch input 3	Input	ON	Lighting, turn, wiper OFF Wiper dial position 4	 SKIA5291E
5	G/B	Combination switch input 2	Input	ON	Lighting, turn, wiper OFF Wiper dial position 4	 SKIA5292E
6	V	Combination switch input 1				
9	Y/B	Rear window defogger switch (Crew Cab)	Input	ON	Rear window defogger switch ON	0V
					Rear window defogger switch OFF	5V
11	O	Ignition switch (ACC or ON)	Input	ACC or ON	Ignition switch ACC or ON	Battery voltage
12	R/L	Front door switch RH (All)	Input	OFF	ON (open)	0V
		Rear door switch lower RH (King Cab)			OFF (closed)	Battery voltage
		Rear door switch upper RH (King Cab)				
13	GR	Rear door switch RH (Crew Cab)	Input	OFF	ON (open)	0V
					OFF (closed)	Battery voltage
15	L/W	Tire pressure warning check connector	Input	OFF	—	5V

# BCM (BODY CONTROL MODULE)

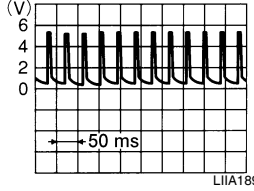
## < ECU DIAGNOSIS >

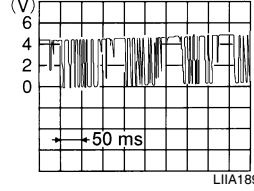
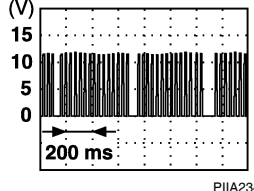
Terminal	Wire color	Signal name	Signal input/output	Measuring condition		Reference value or waveform (Approx.)
				Ignition switch	Operation or condition	
18	P	Remote keyless entry receiver and optical sensor (ground)	Output	OFF	—	0V
19	V/W	Remote keyless entry receiver (power supply)	Output	OFF	Ignition switch OFF	 LIA1893E
20	G/W	Remote keyless entry receiver (signal)	Input	OFF	Stand-by (keyfob buttons released)	 LIA1894E
					When remote keyless entry receiver receives signal from keyfob (keyfob buttons pressed)	 LIA1895E
21	G	NATS antenna amp.	Input	OFF → ON	Ignition switch (OFF → ON)	Just after turning ignition switch ON: Pointer of tester should move for approx. 1 second, then return to battery voltage.
22	G	BUS	—	—	Ignition switch ON or power window timer operates	 PIIA2344E
23	G/O	Security indicator lamp	Output	OFF	Goes OFF → illuminates (Every 2.4 seconds)	Battery voltage → 0V
25	BR	NATS antenna amp.	Input	OFF → ON	Ignition switch (OFF → ON)	Just after turning ignition switch ON: Pointer of tester should move for approx. 1 second, then return to battery voltage.
27	W/R	Compressor ON signal	Input	ON	A/C switch OFF	5V
					A/C switch ON	0V
28	L/R	Front blower monitor	Input	ON	Front blower motor OFF	Battery voltage
					Front blower motor ON	0V
29	W/B	Hazard switch	Input	OFF	ON	0V
					OFF	5V
31	P/L	Cargo lamp switch	Input	OFF	Cargo lamp switch ON	0
					Cargo lamp switch OFF	Battery voltage

A  
B  
C  
D  
E  
F  
G  
H  
I  
J  
K  
L  
M

MWI

O  
P

# BCM (BODY CONTROL MODULE)

## < ECU DIAGNOSIS >

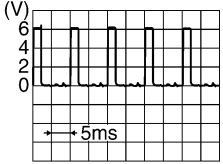
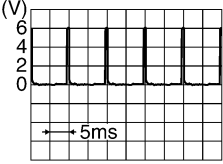
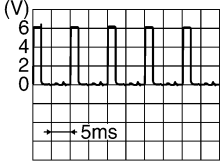
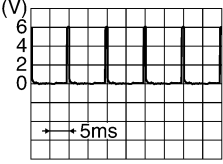
Terminal	Wire color	Signal name	Signal input/output	Measuring condition		Reference value or waveform (Approx.)
				Ignition switch	Operation or condition	
32	R/G	Combination switch output 5	Output	ON	Lighting, turn, wiper OFF Wiper dial position 4	 <p style="text-align: right; font-size: small;">SKIA5291E</p>
33	R/Y	Combination switch output 4	Output	ON	Lighting, turn, wiper OFF Wiper dial position 4	 <p style="text-align: right; font-size: small;">SKIA5292E</p>
34	L	Combination switch output 3	Output	ON	Lighting, turn, wiper OFF Wiper dial position 4	 <p style="text-align: right; font-size: small;">SKIA5291E</p>
35	O/B	Combination switch output 2	Output	ON	Lighting, turn, wiper OFF Wiper dial position 4	 <p style="text-align: right; font-size: small;">SKIA5292E</p>
36	R/W	Combination switch output 1				
37	B/R	Key switch and key lock solenoid	Input	OFF	Key inserted	Battery voltage
					Key inserted	0V
38	W/L	Ignition switch (ON)	Input	ON	—	Battery voltage
39	L	CAN-H	—	—	—	—
40	P	CAN-L	—	—	—	—
47	SB	Front door switch LH (All)	Input	OFF	ON (open)	0V
		Rear door switch lower LH (King Cab)			OFF (closed)	Battery voltage
48	R/Y	Rear door switch LH (Crew Cab)	Input	OFF	ON (open)	0V
					OFF (closed)	Battery voltage
50	R/Y	Cargo bed lamp control	Output	OFF	Cargo lamp switch (ON)	0V
					Cargo lamp switch (OFF)	Battery voltage



# BCM (BODY CONTROL MODULE)

## < ECU DIAGNOSIS >

Terminal	Wire color	Signal name	Signal input/output	Measuring condition		Reference value or waveform (Approx.)
				Ignition switch	Operation or condition	
51	G/Y	Trailer turn signal (right)	Output	ON	Turn right ON	<p style="text-align: right; font-size: small;">SKIA3009J</p>
52	G/B	Trailer turn signal (left)	Output	ON	Turn left ON	<p style="text-align: right; font-size: small;">SKIA3009J</p>
56	R/G	Battery saver output	Output	OFF	30 minutes after ignition switch is turned OFF	0V
				ON	—	Battery voltage
57	Y/R	Battery power supply	Input	OFF	—	Battery voltage
58	W/R	Optical sensor	Input	ON	When optical sensor is illuminated	3.1V or more
					When optical sensor is not illuminated	0.6V or less
59	G	Front door lock assembly LH actuator (unlock)	Output	OFF	OFF (neutral)	0V
					ON (unlock)	Battery voltage
60	G/B	Turn signal (left)	Output	ON	Turn left ON	<p style="text-align: right; font-size: small;">SKIA3009J</p>
61	G/Y	Turn signal (right)	Output	ON	Turn right ON	<p style="text-align: right; font-size: small;">SKIA3009J</p>
62	R/W	Step lamp LH and RH	Output	OFF	ON (any door open)	0V
					OFF (all doors closed)	Battery voltage
63	L	Interior room/map lamp	Output	OFF	Any door switch ON (open)	0V
					OFF (closed)	Battery voltage
65	V	All door lock actuators (lock)	Output	OFF	OFF (neutral)	0V
					ON (lock)	Battery voltage
66	G/Y	Front door lock actuator RH and rear door lock actuators LH/RH (unlock)	Output	OFF	OFF (neutral)	0V
					ON (unlock)	Battery voltage

A  
B  
C  
D  
E  
F  
G  
H  
I  
J  
K  
L  
M  
O  
P

MWI

## BCM (BODY CONTROL MODULE)

### < ECU DIAGNOSIS >

Terminal	Wire color	Signal name	Signal input/output	Measuring condition		Reference value or waveform (Approx.)
				Ignition switch	Operation or condition	
67	B	Ground	Input	ON	—	0V
68	W/L	Power window power supply (RAP)	Output	—	Ignition switch ON	Battery voltage
					Within 45 seconds after ignition switch OFF	Battery voltage
					More than 45 seconds after ignition switch OFF	0V
					When front door LH or RH is open or power window timer operates	0V
69	W/R	Power window power supply	Output	—	—	Battery voltage
70	W/B	Battery power supply	Input	OFF	—	Battery voltage

# BCM (BODY CONTROL MODULE)

< ECU DIAGNOSIS >

## Wiring Diagram

INFOID:000000004215469

### BCM (BODY CONTROL MODULE)

- ◁ AA ▷ : WITH AUTO A/C
- ◁ CC ▷ : CREW CAB
- ◁ CG ▷ : WITH MANUAL 2 CONTROL DIAL SYSTEM
- ◁ CH ▷ : WITH MANUAL 3 CONTROL DIAL SYSTEM
- ◁ CS ▷ : COLUMN SHIFT
- ◁ FS ▷ : FLOOR SHIFT
- ◁ KC ▷ : KING CAB
- ◁ T7 ▷ : TRAILER TOW 7 PIN
- ◁ WI ▷ : WITH IMMOBILIZER
- : DATA LINE

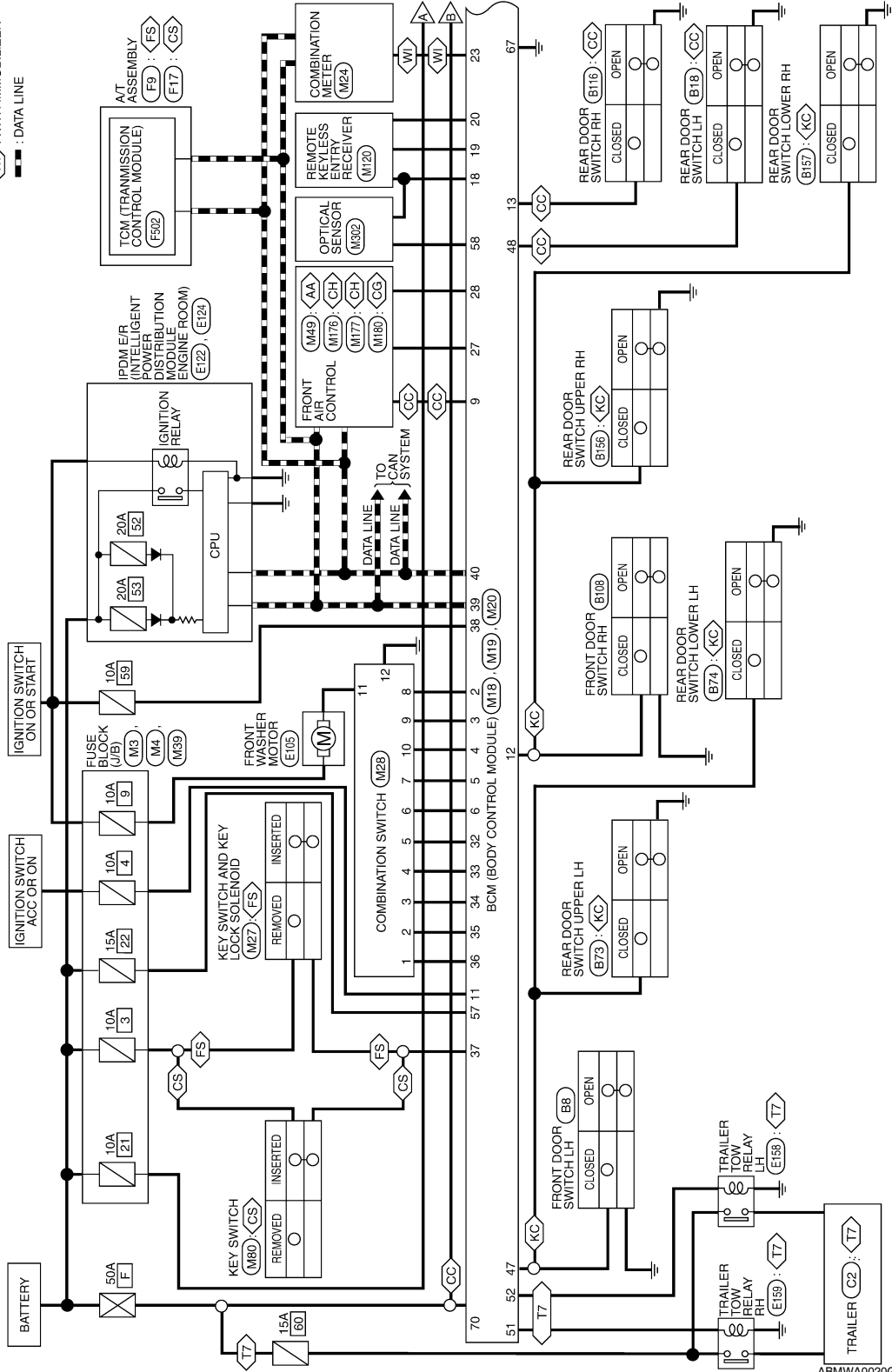

ABMWA0020GI

A  
B  
C  
D  
E  
F  
G  
H  
I  
J  
K  
L  
M  
N  
O  
P

MWI

# BCM (BODY CONTROL MODULE)

< ECU DIAGNOSIS >

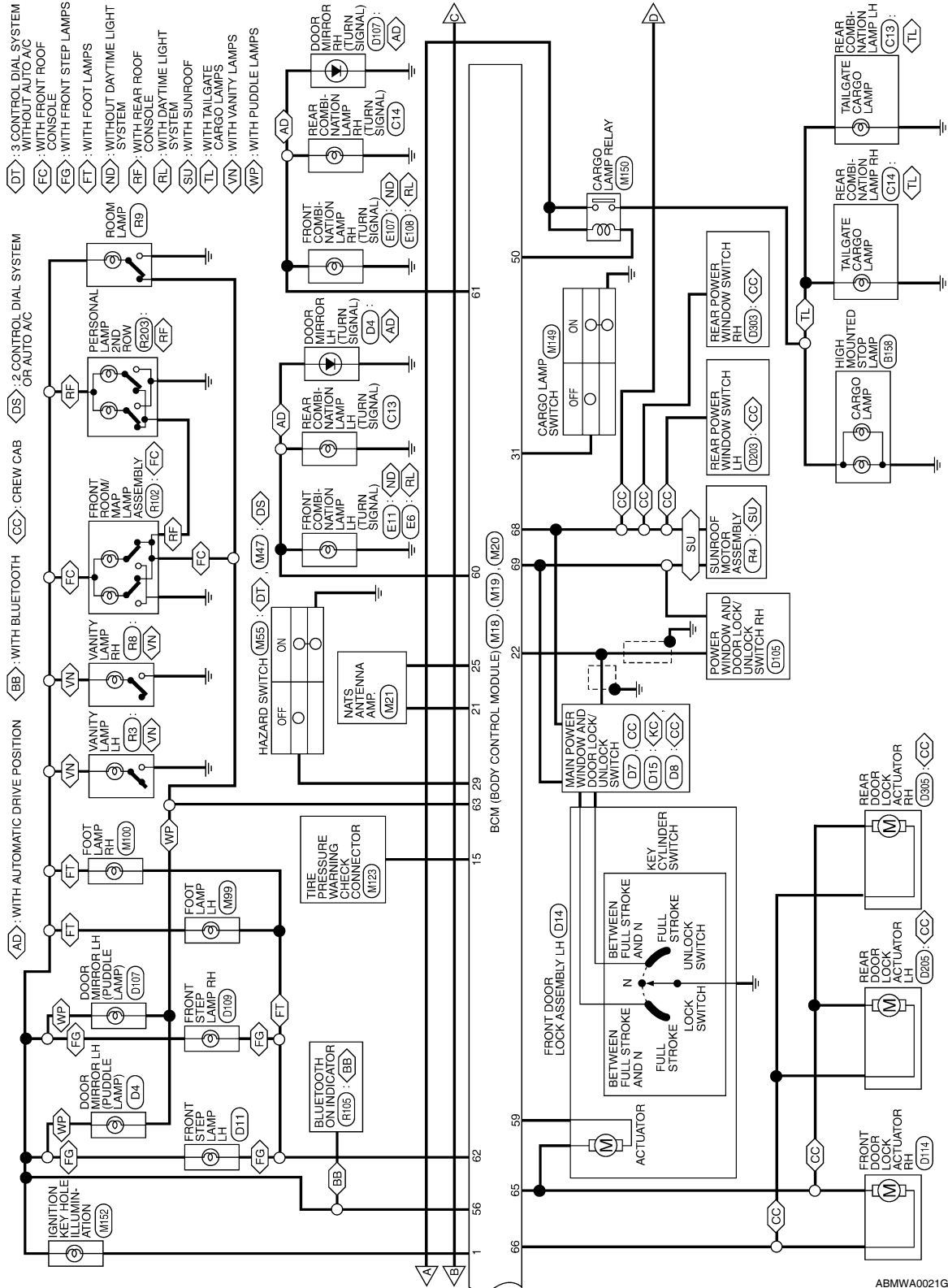

ABMWA0021GI

# BCM (BODY CONTROL MODULE)

< ECU DIAGNOSIS >

◊ CC ◊ : CREW CAB  
 ◊ PS ◊ : WITH POWER SEAT  
 ◊ XP ◊ : WITHOUT POWER SEAT

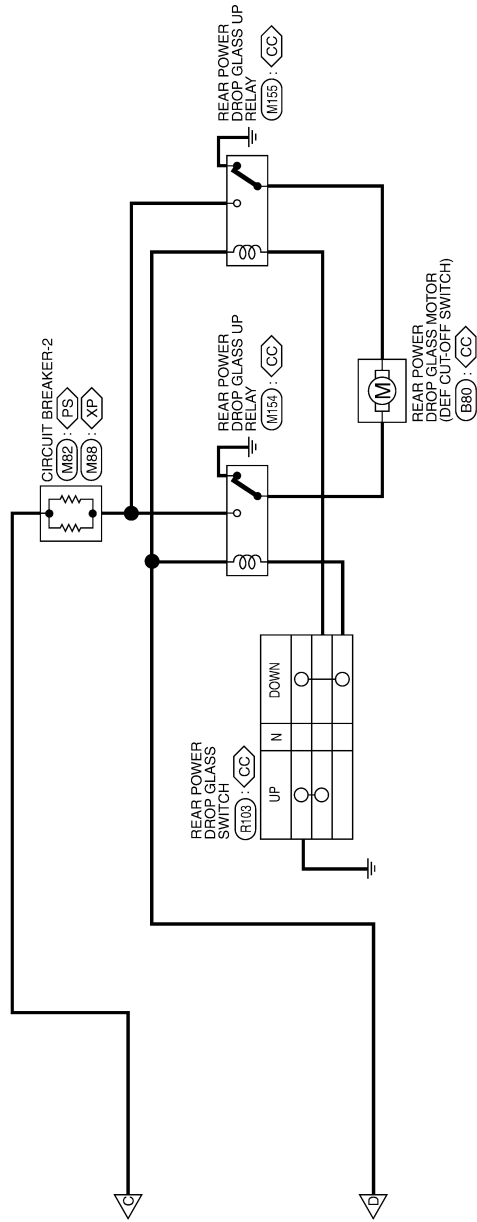

A  
B  
C  
D  
E  
F  
G  
H  
I  
J  
K  
L  
M  
N  
O  
P

MWI

ABMWA0022GI

# BCM (BODY CONTROL MODULE)

< ECU DIAGNOSIS >

## BCM (BODY CONTROL MODULE) CONNECTORS

Connector No.	M18
Connector Name	BCM (BODY CONTROL MODULE)
Connector Color	WHITE



1	2	3	4	5	6	7	8	9	10	11	12	13	14	15	16	17	18	19	20
21	22	23	24	25	26	27	28	29	30	31	32	33	34	35	36	37	38	39	40

Terminal No.	Color of Wire	Signal Name
1	BR/W	KEY RING OUTPUT
2	SB	INPUT 5
3	G/Y	INPUT 4
4	Y	INPUT 3
5	G/B	INPUT 2
6	V	INPUT 1
7	-	-
8	-	-
9	Y/B	REAR DEFOGGER SW
10	-	-
11	O	ACC SW
12	R/L	DOOR SW (AS)
13	GR	DOOR SW (RR)
14	-	-
15	L/W	TPMS MODE TRIGGER SW

Terminal No.	Color of Wire	Signal Name
16	-	-
17	-	-
18	P	KEYLESS AND AUTO LIGHT SENSOR GND
19	V/W	KEYLESS TUNER POWER SUPPLY OUTPUT
20	GW	KEYLESS TUNER SIGNAL
21	G	IMMOBILIZER ANTENNA SIGNAL (CLOCK)
22	G	ANTI-PINCH SERIAL LINK (RX, TX)
23	G/O	SECURITY INDICATOR OUTPUT
24	-	-
25	BR	IMMOBILIZER ANTENNA SIGNAL (RX, TX)
26	-	-
27	W/R	AIRCON SW
28	L/R	BLOWER FAN SW
29	W/B	HAZARD SW
30	-	-
31	P/L	CARGO LAMP SW
32	R/G	OUTPUT 5
33	R/Y	OUTPUT 4
34	L	OUTPUT 3
35	O/B	OUTPUT 2
36	R/W	OUTPUT 1
37	B/R	KEY SW
38	W/L	IGN SW
39	L	CAN-H
40	P	CAN-L

Connector No.	M19
Connector Name	BCM (BODY CONTROL MODULE)
Connector Color	WHITE



41	42	43	44	45	46	47	48	49
50	51	52	53	54	55			

Terminal No.	Color of Wire	Signal Name
41	-	-
42	-	-
43	-	-
44	-	-
45	-	-
46	-	-
47	SB	DOOR SW (DR)
48	R/Y	DOOR SW (RL)
49	-	-
50	R/Y	CARGO LAMP OUTPUT
51	G/Y	TRAILER FLASHER OUTPUT (RIGHT)
52	G/B	TRAILER FLASHER OUTPUT (LEFT)
53	-	-
54	-	-
55	-	-

ABMIA0027GB

# BCM (BODY CONTROL MODULE)

< ECU DIAGNOSIS >

A  
B  
C  
D  
E  
F  
G  
H  
I  
J  
K  
L  
M  
N  
O  
P

Connector No.	M28
Connector Name	COMBINATION SWITCH
Connector Color	WHITE

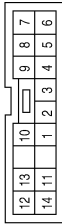

Terminal No.	Color of Wire	Signal Name
1	R/W	INPUT 1
2	O/B	INPUT 2
3	L	INPUT 3
4	R/Y	INPUT 4
5	R/G	INPUT 5
6	V	OUTPUT 1
7	G/B	OUTPUT 2
8	SB	OUTPUT 5
9	G/Y	OUTPUT 4
10	Y	OUTPUT 3
11	V/W	WASHER MOTOR
12	B	GND
13	-	-
14	-	-

Connector No.	M20
Connector Name	BCM (BODY CONTROL MODULE)
Connector Color	BLACK



Terminal No.	Color of Wire	Signal Name
56	R/G	BATTERY SAVER OUTPUT
57	Y/R	BAT (FUSE)
58	W/R	AUTO LIGHT SENSOR INPUT 2
59	G	DOOR UNLOCK OUTPUT (DR)
60	G/B	FLASHER OUTPUT (LEFT)
61	G/Y	FLASHER OUTPUT (RIGHT)
62	R/W	STEP LAMP OUTPUT
63	L	ROOM LAMP
64	-	-
65	V	DOOR LOCK OUTPUT (ALL)
66	G/Y	DOOR UNLOCK OUTPUT (OTHER)
67	B	GND (POWER)
68	W/L	POWER WINDOW POWER SUPPLY (RAP)
69	W/R	POWER WINDOW POWER SUPPLY (BAT)
70	W/B	BAT (F/L)

## Fail Safe

### Fail-safe index

BCM performs fail-safe control when any DTC listed below is detected.

ABMIA0028GB

INFOID:000000004215470



# BCM (BODY CONTROL MODULE)

## < ECU DIAGNOSIS >

Display contents of CONSULT	Fail-safe	Cancellation
U1000: CAN COMM CIRCUIT	Inhibit engine cranking	When the BCM re-establishes communication with the other modules.
U1010: CONTROL UNIT (CAN)	Inhibit engine cranking	When the BCM re-start communicating with the other modules.

## DTC Inspection Priority Chart

INFOID:000000004215471

If some DTCs are displayed at the same time, perform inspections one by one based on the following priority chart.

Priority	DTC
1	<ul style="list-style-type: none"> <li>• U1000: CAN COMM CIRCUIT</li> <li>• U1010: CONTROL UNIT (CAN)</li> </ul>
2	<ul style="list-style-type: none"> <li>• B2190: NATS ANTENNA AMP</li> <li>• B2191: DIFFERENCE OF KEY</li> <li>• B2192: ID DISCORD BCM-ECM</li> <li>• B2193: CHAIN OF BCM-ECM</li> </ul>
3	<ul style="list-style-type: none"> <li>• C1729: VHCL SPEED SIG ERR</li> <li>• C1735: IGNITION SIGNAL</li> </ul>
4	<ul style="list-style-type: none"> <li>• C1704: LOW PRESSURE FL</li> <li>• C1705: LOW PRESSURE FR</li> <li>• C1706: LOW PRESSURE RR</li> <li>• C1707: LOW PRESSURE RL</li> <li>• C1708: [NO DATA] FL</li> <li>• C1709: [NO DATA] FR</li> <li>• C1710: [NO DATA] RR</li> <li>• C1711: [NO DATA] RL</li> <li>• C1712: [CHECKSUM ERR] FL</li> <li>• C1713: [CHECKSUM ERR] FR</li> <li>• C1714: [CHECKSUM ERR] RR</li> <li>• C1715: [CHECKSUM ERR] RL</li> <li>• C1716: [PRESSDATA ERR] FL</li> <li>• C1717: [PRESSDATA ERR] FR</li> <li>• C1718: [PRESSDATA ERR] RR</li> <li>• C1719: [PRESSDATA ERR] RL</li> <li>• C1720: [CODE ERR] FL</li> <li>• C1721: [CODE ERR] FR</li> <li>• C1722: [CODE ERR] RR</li> <li>• C1723: [CODE ERR] RL</li> <li>• C1724: [BATT VOLT LOW] FL</li> <li>• C1725: [BATT VOLT LOW] FR</li> <li>• C1726: [BATT VOLT LOW] RR</li> <li>• C1727: [BATT VOLT LOW] RL</li> </ul>

## DTC Index

INFOID:000000004215472

### NOTE:

- Details of time display
- CRNT: Displays when there is a malfunction now or after returning to the normal condition until turning ignition switch OFF → ON again.
- 1 - 39: Displayed if any previous malfunction is present when current condition is normal. It increases like 1 → 2 → 3...38 → 39 after returning to the normal condition whenever ignition switch OFF → ON. The counter remains at 39 even if the number of cycles exceeds it. It is counted from 1 again when turning ignition switch OFF → ON after returning to the normal condition if the malfunction is detected again.



## BCM (BODY CONTROL MODULE)

### < ECU DIAGNOSIS >

CONSULT display	Fail-safe	Tire pressure monitor warning lamp ON	Reference page
No DTC is detected. further testing may be required.	—	—	—
U1000: CAN COMM CIRCUIT	—	—	<a href="#">BCS-28</a>
U1010: CONTROL UNIT (CAN)	—	—	<a href="#">BCS-29</a>
B2190: NATS ANTENA AMP	—	—	<a href="#">SEC-17</a>
B2191: DIFFERENCE OF KEY	—	—	<a href="#">SEC-20</a>
B2192: ID DISCORD BCM-ECM	—	—	<a href="#">SEC-21</a>
B2193: CHAIN OF BCM-ECM	—	—	<a href="#">SEC-23</a>
C1708: [NO DATA] FL	—	—	<a href="#">WT-14</a>
C1709: [NO DATA] FR	—	—	<a href="#">WT-14</a>
C1710: [NO DATA] RR	—	—	<a href="#">WT-14</a>
C1711: [NO DATA] RL	—	—	<a href="#">WT-14</a>
C1712: [CHECKSUM ERR] FL	—	—	<a href="#">WT-16</a>
C1713: [CHECKSUM ERR] FR	—	—	<a href="#">WT-16</a>
C1714: [CHECKSUM ERR] RR	—	—	<a href="#">WT-16</a>
C1715: [CHECKSUM ERR] RL	—	—	<a href="#">WT-16</a>
C1716: [PRESSDATA ERR] FL	—	—	<a href="#">WT-18</a>
C1717: [PRESSDATA ERR] FR	—	—	<a href="#">WT-18</a>
C1718: [PRESSDATA ERR] RR	—	—	<a href="#">WT-18</a>
C1719: [PRESSDATA ERR] RL	—	—	<a href="#">WT-18</a>
C1720: [CODE ERR] FL	—	—	<a href="#">WT-16</a>
C1721: [CODE ERR] FR	—	—	<a href="#">WT-16</a>
C1722: [CODE ERR] RR	—	—	<a href="#">WT-16</a>
C1723: [CODE ERR] RL	—	—	<a href="#">WT-16</a>
C1724: [BATT VOLT LOW] FL	—	—	<a href="#">WT-16</a>
C1725: [BATT VOLT LOW] FR	—	—	<a href="#">WT-16</a>
C1726: [BATT VOLT LOW] RR	—	—	<a href="#">WT-16</a>
C1727: [BATT VOLT LOW] RL	—	—	<a href="#">WT-16</a>
C1729: VHCL SPEED SIG ERR	—	—	<a href="#">WT-19</a>
C1735: IGNITION SIGNAL	—	—	<a href="#">WT-20</a>

A

B

C

D

E

F

G

H

I

J

K

L

M

MWI

O

P

# IPDM E/R (INTELLIGENT POWER DISTRIBUTION MODULE ENGINE ROOM)

< ECU DIAGNOSIS >

## IPDM E/R (INTELLIGENT POWER DISTRIBUTION MODULE ENGINE ROOM)

Reference Value

INFOID:000000004215473

VALUES ON THE DIAGNOSIS TOOL

Monitor Item	Condition		Value/Status
MOTOR FAN REQ	Engine idle speed	Changes depending on engine coolant temperature, air conditioner operation status, vehicle speed, etc.	0 - 100 %
A/C COMP REQ	A/C switch OFF		OFF
	A/C switch ON		ON
TAIL&CLR REQ	Lighting switch OFF		OFF
	Lighting switch 1ST, 2ND, HI or AUTO (Light is illuminated)		ON
HL LO REQ	Lighting switch OFF		OFF
	Lighting switch 2ND HI or AUTO (Light is illuminated)		ON
HL HI REQ	Lighting switch OFF		OFF
	Lighting switch HI		ON
FR FOG REQ*	Lighting switch 2ND or AUTO (Light is illuminated)	Front fog lamp switch OFF	OFF
		<ul style="list-style-type: none"> <li>• Front fog lamp switch ON</li> <li>• Daytime light activated (Canada only)</li> </ul>	ON
HL WASHER REQ	<b>NOTE:</b> This item is displayed, but cannot be monitored.		OFF
FR WIP REQ	Ignition switch ON	Front wiper switch OFF	STOP
		Front wiper switch INT	1LOW
		Front wiper switch LO	LOW
		Front wiper switch HI	HI
WIP AUTO STOP	Ignition switch ON	Front wiper stop position	STOP P
		Any position other than front wiper stop position	ACT P
WIP PROT	Ignition switch ON	Front wiper operates normally	OFF
		Front wiper stops at fail-safe operation	BLOCK
ST RLY REQ	Ignition switch OFF or ACC		OFF
	Ignition switch START		ON
IGN RLY	Ignition switch OFF or ACC		OFF
	Ignition switch ON		ON
RR DEF REQ*	Rear defogger switch OFF		OFF
	Rear defogger switch ON		ON
OIL P SW	Ignition switch OFF, ACC or engine running		OPEN
	Ignition switch ON		CLOSE
DTRL REQ	<b>NOTE:</b> This item is displayed, but cannot be monitored.		OFF
HOOD SW	<b>NOTE:</b> This item is displayed, but cannot be monitored.		OFF

# IPDM E/R (INTELLIGENT POWER DISTRIBUTION MODULE ENGINE ROOM)

## < ECU DIAGNOSIS >

Monitor Item	Condition	Value/Status
THFT HRN REQ	Not operated	OFF
	<ul style="list-style-type: none"> <li>• Panic alarm is activated</li> <li>• Horn is activated with VEHICLE SECURITY (THEFT WARNING) SYSTEM</li> </ul>	ON
HORN CHIRP	Not operated	OFF
	Door locking with keyfob (horn chirp mode)	ON

\*: If equipped

A  
B  
C  
D  
E  
F  
G  
H  
I  
J  
K  
L  
M  
O  
P

MWI

# IPDM E/R (INTELLIGENT POWER DISTRIBUTION MODULE ENGINE ROOM)

< ECU DIAGNOSIS >

## Terminal Layout

INFOID:000000004244475

### TERMINAL LAYOUT

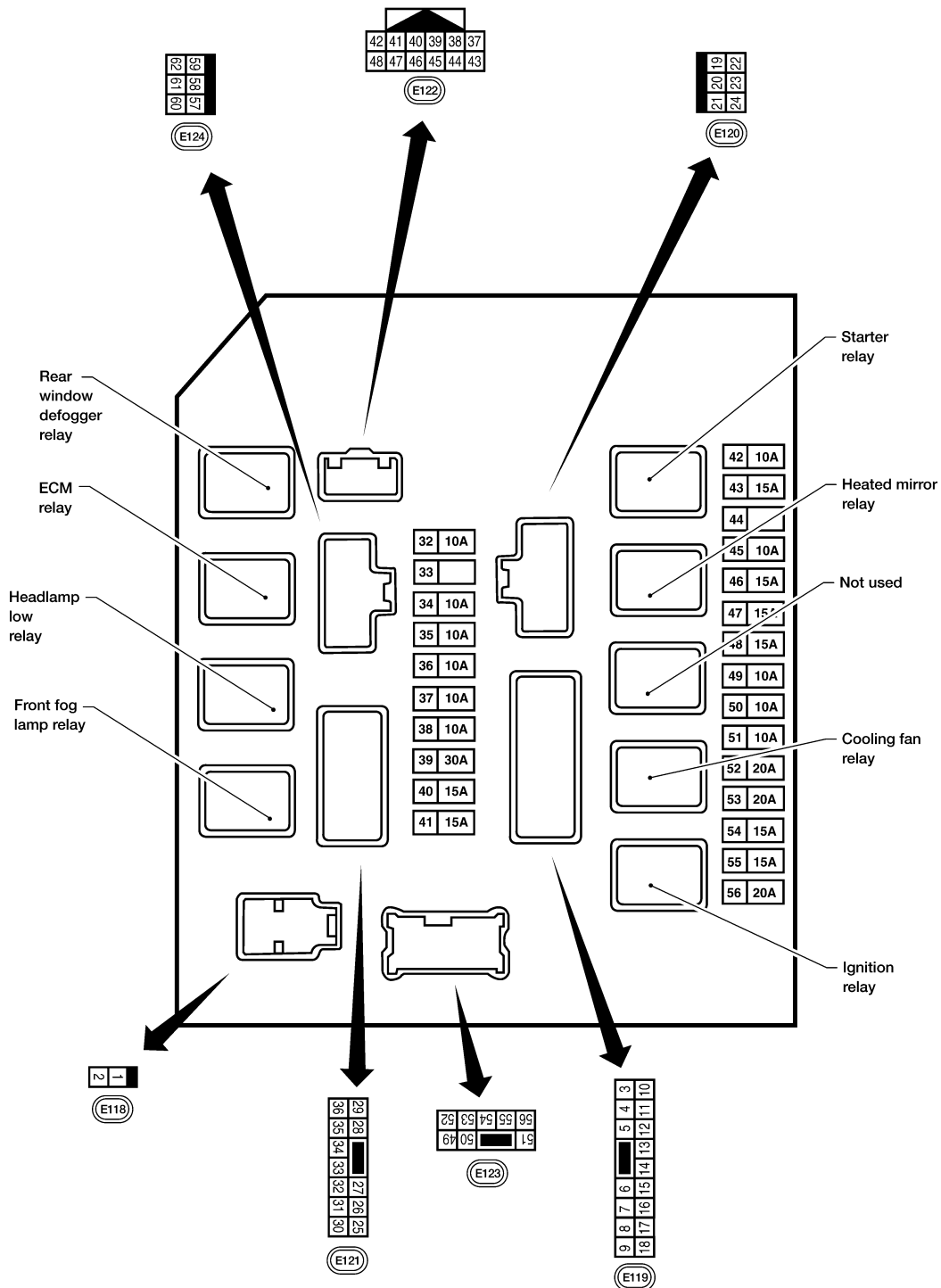

Physical Values

PHYSICAL VALUES

WKIA5852E

INFOID:000000004215475

# IPDM E/R (INTELLIGENT POWER DISTRIBUTION MODULE ENGINE ROOM)

## < ECU DIAGNOSIS >

Terminal	Wire color	Signal name	Signal input/output	Measuring condition		Reference value (Approx.)	
				Ignition switch	Operation or condition		
1	B/Y	Battery power supply	Input	OFF	—	Battery voltage	
2	R	Battery power supply	Input	OFF	—	Battery voltage	
3	BR	ECM relay	Output	—	Ignition switch ON or START	Battery voltage	
					Ignition switch OFF or ACC	0V	
4	W/L	ECM relay	Output	—	Ignition switch ON or START	Battery voltage	
					Ignition switch OFF or ACC	0V	
6	L	Throttle control motor relay	Output	—	Ignition switch ON or START	Battery voltage	
					Ignition switch OFF or ACC	0V	
7	W/B	ECM relay control	Input	—	Ignition switch ON or START	0V	
					Ignition switch OFF or ACC	Battery voltage	
8	R/B	Fuse 54	Output	—	Ignition switch ON or START	Battery voltage	
					Ignition switch OFF or ACC	0V	
10	G	Fuse 45 (Canada only)	Output	ON	Daytime light system active	0V	
					Daytime light system inactive	Battery voltage	
11	Y/B	A/C compressor	Output	ON or START	A/C switch ON or defrost A/C switch	Battery voltage	
					A/C switch OFF or defrost A/C switch	0V	
12	L/W	Ignition switch supplied power	Input	—	OFF or ACC	0V	
					ON or START	Battery voltage	
13	B/Y	Fuel pump relay	Output	—	Ignition switch ON or START	Battery voltage	
					Ignition switch OFF or ACC	0V	
14	Y/R	Fuse 49	Output	—	Ignition switch ON or START	Battery voltage	
					Ignition switch OFF or ACC	0V	
15	LG/B (with VDC) GR (with ABS) G/R (with ABLs)	Fuse 50	Output	—	Ignition switch ON or START	Battery voltage	
					Ignition switch OFF or ACC	0V	
16	G	Fuse 51	Output	—	Ignition switch ON or START	Battery voltage	
					Ignition switch OFF or ACC	0V	
17	W	Fuse 55	Output	—	Ignition switch ON or START	Battery voltage	
					Ignition switch OFF or ACC	0V	
19	W/R	Starter motor	Output	START	—	Battery voltage	
21	BR	Ignition switch supplied power	Input	—	OFF or ACC	0V	
					START	Battery voltage	
22	G	Battery power supply	Output	OFF	—	Battery voltage	
23	GR/W	Door mirror defogger output signal (if equipped)	Output	—	When rear defogger switch is ON	Battery voltage	
					When raker defogger switch is OFF	0V	
27	W/B	Fuse 38 (With trailer tow)	Output	—	Ignition switch ON or START	Battery voltage	
					Ignition switch OFF or ACC	0V	
30	W	Fuse 53	Output	—	Ignition switch ON or START	Battery voltage	
					Ignition switch OFF or ACC	0V	
32	L	Wiper low speed signal	Output	ON or START	Wiper switch	OFF	Battery voltage
						LO or INT	0V

A

B

C

D

E

F

G

H

I

J

K

L

M

MWI

O

P

# IPDM E/R (INTELLIGENT POWER DISTRIBUTION MODULE ENGINE ROOM)

## < ECU DIAGNOSIS >

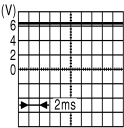
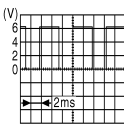
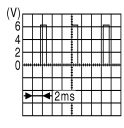
Terminal	Wire color	Signal name	Signal input/output	Measuring condition		Reference value (Approx.)
				Ignition switch	Operation or condition	
35	L/B	Wiper high speed signal	Output	ON or START	Wiper switch OFF, LO, INT HI	Battery voltage 0V
37	Y	Power generation command signal	Output	—	Ignition switch ON	 <p style="text-align: right;">JPMIA0001GB</p> <p style="text-align: center;">6.3 V</p>
					40% is set on "Active test," "ALTERNATOR DUTY" of "ENGINE"	 <p style="text-align: right;">JPMIA0002GB</p> <p style="text-align: center;">3.8 V</p>
					40% is set on "Active test," "ALTERNATOR DUTY" of "ENGINE"	 <p style="text-align: right;">JPMIA0003GB</p> <p style="text-align: center;">1.4 V</p>
38	B	Ground	Input	—	—	0V
39	L	CAN-H	—	ON	—	—
40	P	CAN-L	—	ON	—	—
42	GR	Oil pressure switch	Input	—	Engine running	Battery voltage
					Engine stopped	0V
43	L/Y	Wiper auto stop signal	Input	ON or START	Wiper switch OFF, LO, INT	Battery voltage
44	BR	Daytime light relay control (Canada only)	Input	ON	Daytime light system active	0V
					Daytime light system inactive	Battery voltage
45	G/W	Horn relay control	Input	ON	When door locks are operated using keyfob (OFF → ON)*	Battery voltage → 0V
46	GR	Fuel pump relay control	Input	—	Ignition switch ON or START	0V
					Ignition switch OFF or ACC	Battery voltage
47	O	Throttle control motor relay control	Input	—	Ignition switch ON or START	0V
					Ignition switch OFF or ACC	Battery voltage
48	B/R	Starter relay (inhibit switch)	Input	ON or START	Selector lever in "P" or "N"	0V
					Selector lever any other position	Battery voltage

# IPDM E/R (INTELLIGENT POWER DISTRIBUTION MODULE ENGINE ROOM)

## < ECU DIAGNOSIS >

Terminal	Wire color	Signal name	Signal input/output	Measuring condition		Reference value (Approx.)
				Ignition switch	Operation or condition	
49	R/L	Trailer tow relay (With trailer tow) Illumination (Without trailer tow)	Output	ON	Lighting switch must be in the 1st position	OFF 0V
						ON Battery voltage
50	W/R	Front fog lamp (LH) (if equipped)	Output	ON or START	Lighting switch must be in the 2nd position (LOW beam is ON) and the front fog lamp switch	OFF 0V
						ON Battery voltage
51	W/R	Front fog lamp (RH) (if equipped)	Output	ON or START	Lighting switch must be in the 2nd position (LOW beam is ON) and the front fog lamp switch	OFF 0V
						ON Battery voltage
52	L	LH low beam head-lamp	Output	—	Lighting switch in 2nd position	Battery voltage
54	R/Y	RH low beam head-lamp	Output	—	Lighting switch in 2nd position	Battery voltage
55	G	LH high beam head-lamp	Output	—	Lighting switch in 2nd position and placed in HIGH or PASS position	Battery voltage
56	Y (With DTRL) L/W (Without DTRL)	RH high beam head-lamp	Output	—	Lighting switch in 2nd position and placed in HIGH or PASS position	Battery voltage
57	R/L	Parking, license, tail lamp and rear audio remote control unit	Output	ON	Lighting switch 1st position	OFF 0V
						ON Battery voltage
59	B	Ground	Input	—	—	0V
60	B/W	Rear window defogger relay (if equipped)	Output	ON or START	Rear defogger switch ON	Battery voltage
					Rear defogger switch OFF	0V
61	BR	Fuse 32 (With trailer tow)	Output	OFF	—	Battery voltage

\*: When horn reminder is ON

A  
B  
C  
D  
E  
F  
G  
H  
I  
J  
K  
L  
M  
N  
O  
P

MWI

# IPDM E/R (INTELLIGENT POWER DISTRIBUTION MODULE ENGINE ROOM)

< ECU DIAGNOSIS >

## Wiring Diagram

INFOID:000000004215476

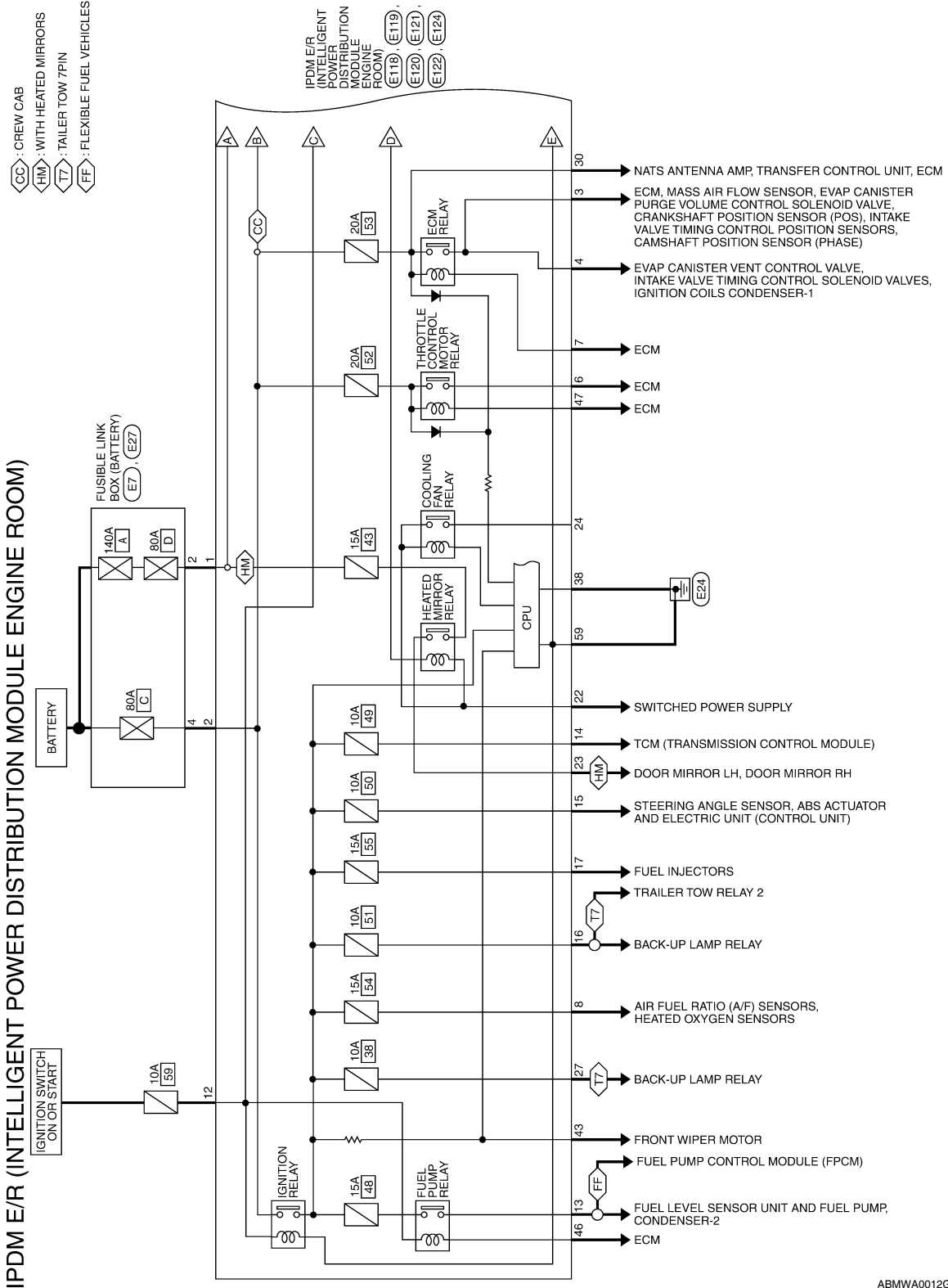

ABMWA0012GI



# IPDM E/R (INTELLIGENT POWER DISTRIBUTION MODULE ENGINE ROOM)

## < ECU DIAGNOSIS >

- : TRAILER TOW 7PIN
- : CREW CAB
- : WITH FRONT FOG LAMP
- : FOR CANADA
- : DATA LINE

IPDM E/R  
INTELLIGENT  
POWER  
DISTRIBUTION  
MODULE  
ENGINE  
ROOM  
(E119)  
(E120)  
(E121)  
(E122)  
(E123)  
(E124)

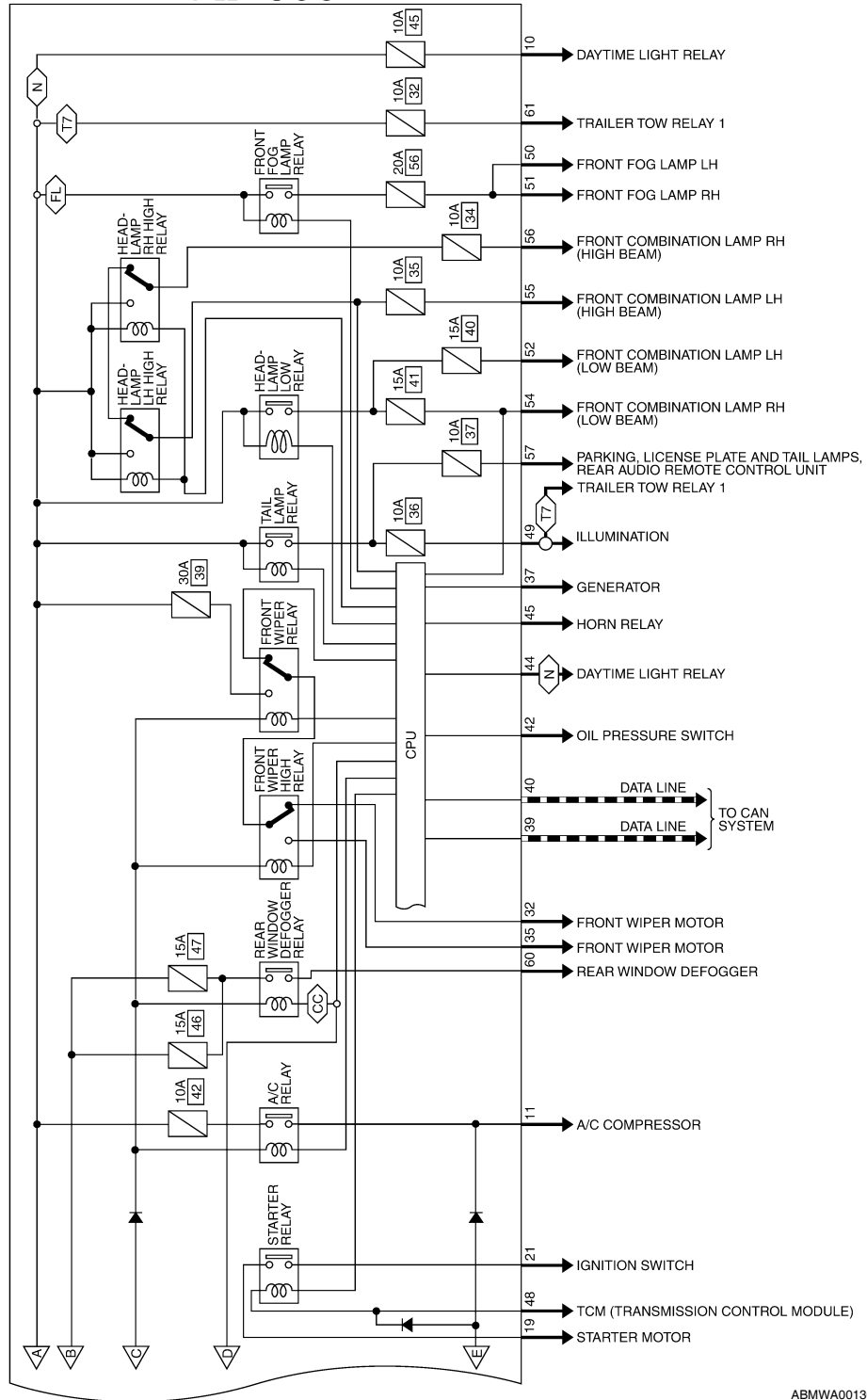

ABMWA0013GI

A  
B  
C  
D  
E  
F  
G  
H  
I  
J  
K  
L  
M  
N  
O  
P

MWI

# IPDM E/R (INTELLIGENT POWER DISTRIBUTION MODULE ENGINE ROOM)

< ECU DIAGNOSIS >

## IPDM E/R (INTELLIGENT POWER DISTRIBUTION MODULE ENGINE ROOM) CONNECTORS

Connector No.	E7
Connector Name	FUSIBLE LINK BOX (BATTERY)
Connector Color	BLACK



Terminal No.	4	Color of Wire	R	Signal Name	-
--------------	---	---------------	---	-------------	---

Connector No.	E27
Connector Name	FUSIBLE LINK BOX (BATTERY)
Connector Color	BROWN



Terminal No.	2	Color of Wire	B/Y	Signal Name	-
--------------	---	---------------	-----	-------------	---

Connector No.	E118
Connector Name	IPDM E/R (INTELLIGENT POWER DISTRIBUTION MODULE ENGINE ROOM)
Connector Color	BLACK



Terminal No.	1	Color of Wire	B/Y	Signal Name	F/L USM
Terminal No.	2	Color of Wire	R	Signal Name	F/L MAIN

Connector No.	E119
Connector Name	IPDM E/R (INTELLIGENT POWER DISTRIBUTION MODULE ENGINE ROOM)
Connector Color	WHITE

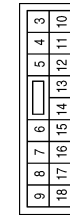

Terminal No.	3	Color of Wire	BR	Signal Name	IGN COIL
Terminal No.	4	Color of Wire	W/L	Signal Name	ECM
Terminal No.	5	Color of Wire	-	Signal Name	-
Terminal No.	6	Color of Wire	L	Signal Name	ETC
Terminal No.	7	Color of Wire	W/B	Signal Name	ECM RLY CONT

Terminal No.	8	Color of Wire	R/B	Signal Name	02_SENSOR
Terminal No.	9	Color of Wire	-	Signal Name	-
Terminal No.	10	Color of Wire	G	Signal Name	DTRL RLY SUPPLY
Terminal No.	11	Color of Wire	Y/B	Signal Name	A/C COMPRESSOR
Terminal No.	12	Color of Wire	L/W	Signal Name	IGN SW (IG)
Terminal No.	13	Color of Wire	B/Y	Signal Name	FUEL PUMP
Terminal No.	14	Color of Wire	Y/R	Signal Name	A/T CU IGN SUPPLY
Terminal No.	15	Color of Wire	LG/B	Signal Name	ABS IGN SUPPLY (WITH VDC)
Terminal No.	15	Color of Wire	GR	Signal Name	ABS IGN SUPPLY (WITH ABS)
Terminal No.	15	Color of Wire	G/R	Signal Name	ABS IGN SUPPLY (WITH ABL)
Terminal No.	16	Color of Wire	G	Signal Name	REVERSE LAMP
Terminal No.	17	Color of Wire	W	Signal Name	INJECTOR
Terminal No.	18	Color of Wire	-	Signal Name	-

Connector No.	E120
Connector Name	IPDM E/R (INTELLIGENT POWER DISTRIBUTION MODULE ENGINE ROOM)
Connector Color	WHITE

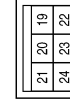

Terminal No.	19	Color of Wire	W/R	Signal Name	STARTER MTR
Terminal No.	20	Color of Wire	-	Signal Name	-
Terminal No.	21	Color of Wire	BR	Signal Name	IGN SW(ST)
Terminal No.	22	Color of Wire	G	Signal Name	F/L MOTOR FAN
Terminal No.	23	Color of Wire	GR/W	Signal Name	HEATED MIRROR
Terminal No.	24	Color of Wire	-	Signal Name	-

ABMIA0021GB

# IPDM E/R (INTELLIGENT POWER DISTRIBUTION MODULE ENGINE ROOM)

< ECU DIAGNOSIS >

Connector No.	E123
Connector Name	IPDM E/R (INTELLIGENT POWER DISTRIBUTION MODULE ENGINE ROOM)
Connector Color	BROWN

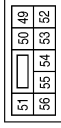

Terminal No.	Color of Wire	Signal Name
49	R/L	ILLUMINATION
50	W/R	FR FOG LAMP LH
51	W/R	FR FOG LAMP RH
52	L	H/LAMP LO LH
53	-	-
54	R/Y	H/LAMP LO RH
55	G	H/LAMP HI LH
56	L/W	H/LAMP HI RH (WITHOUT DAYTIME LIGHT)
56	Y	H/LAMP HI RH (WITH DAYTIME LIGHT)

Connector No.	E122
Connector Name	IPDM E/R (INTELLIGENT POWER DISTRIBUTION MODULE ENGINE ROOM)
Connector Color	WHITE



Terminal No.	Color of Wire	Signal Name
37	Y	ALT-C CONT
38	B	GND (SIGNAL)
39	L	CAN-H
40	P	CAN-L
41	-	-
42	GR	OIL PRESSURE SW
43	L/Y	AUTO STOP SW
44	BR	DTRL RLY CONT
45	G/W	ANT THEFT HORN
46	GR	FUEL PUMP RLY CONT
47	O	ETC RLY CONT
48	B/R	INHIBIT SW

Connector No.	E121
Connector Name	IPDM E/R (INTELLIGENT POWER DISTRIBUTION MODULE ENGINE ROOM)
Connector Color	BROWN

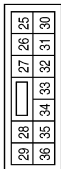

Terminal No.	Color of Wire	Signal Name
25	-	-
26	-	-
27	W/B	T TOW REV LAMP
28	-	-
29	-	-
30	W	ECM BAT
31	-	-
32	L	FR WIPER LO
33	-	-
34	-	-
35	L/B	FR WIPER HI
36	-	-

Terminal No.	Color of Wire	Signal Name
57	R/L	TAIL LAMP
58	-	-
59	B	GND (POWER)
60	B/W	RR DEF
61	BR	TRAIL RLY SUPPLY
62	-	-

Connector No.	E124
Connector Name	IPDM E/R (INTELLIGENT POWER DISTRIBUTION MODULE ENGINE ROOM)
Connector Color	BLACK



## Fail Safe

### CAN COMMUNICATION CONTROL

When CAN communication with ECM and BCM is impossible, IPDM E/R performs fail-safe control. After CAN communication recovers normally, it also returns to normal control.

If No CAN Communication Is Available With ECM

ABMIA0022GB

INFOID:000000004215477

A  
B  
C  
D  
E  
F  
G  
H  
I  
J  
K  
L  
M  
N  
O  
P

# IPDM E/R (INTELLIGENT POWER DISTRIBUTION MODULE ENGINE ROOM)

## < ECU DIAGNOSIS >

Control part	Fail-safe in operation
Cooling fan	<ul style="list-style-type: none"> <li>• Turns ON the cooling fan relay when the ignition switch is turned ON</li> <li>• Turns OFF the cooling fan relay when the ignition switch is turned OFF</li> </ul>

### If No CAN Communication Is Available With BCM

Control part	Fail-safe in operation
Headlamp	<ul style="list-style-type: none"> <li>• Turns ON the headlamp low relay when the ignition switch is turned ON</li> <li>• Turns OFF the headlamp low relay when the ignition switch is turned OFF</li> <li>• Headlamp high LH/RH relays OFF</li> </ul>
<ul style="list-style-type: none"> <li>• Parking lamps</li> <li>• License plate lamps</li> <li>• Tail lamps</li> </ul>	<ul style="list-style-type: none"> <li>• Turns ON the tail lamp relay when the ignition switch is turned ON</li> <li>• Turns OFF the tail lamp relay when the ignition switch is turned OFF</li> </ul>
Front wiper	<ul style="list-style-type: none"> <li>• The status just before activation of fail-safe control is maintained until the ignition switch is turned OFF while the front wiper is operating at LO or HI speed.</li> <li>• The wiper is operated at LO speed until the ignition switch is turned OFF if the fail-safe control is activated while the front wiper is set in the INT mode and the front wiper motor is operating.</li> </ul>
Rear window defogger (if equipped)	Rear window defogger relay OFF
A/C compressor	A/C relay OFF
Front fog lamps (if equipped)	Front fog lamp relay OFF

### IGNITION RELAY MALFUNCTION DETECTION FUNCTION

- IPDM E/R monitors the voltage at the contact circuit and excitation coil circuit of the ignition relay inside it.
- IPDM E/R judges the ignition relay error if the voltage differs between the contact circuit and the excitation coil circuit.
- If the ignition relay cannot turn OFF due to contact seizure, it activates the tail lamp relay for 10 minutes to alert the user to the ignition relay malfunction when the ignition switch is turned OFF.

Ignition switch	Ignition relay	Tail lamp relay
ON	ON	—
OFF	OFF	—

#### NOTE:

The tail lamp turns OFF when the ignition switch is turned ON.

### FRONT WIPER CONTROL

IPDM E/R detects front wiper stop position by a front wiper auto stop signal.

When a front wiper auto stop signal is in the conditions listed below, IPDM E/R stops power supply to wiper after repeating a front wiper 10 second activation and 20 second stop five times.

Ignition switch	Front wiper switch	Auto stop signal
ON	OFF	Front wiper stop position signal cannot be input 10 seconds.
	ON	The signal does not change for 10 seconds.

#### NOTE:

This operation status can be confirmed on the IPDM E/R “DATA MONITOR” that displays “Block” for the item “WIP PROT” while the wiper is stopped.

### STARTER MOTOR PROTECTION FUNCTION

IPDM E/R turns OFF the starter control relay to protect the starter motor when the starter control relay remains active for 90 seconds.

# IPDM E/R (INTELLIGENT POWER DISTRIBUTION MODULE ENGINE ROOM)

< ECU DIAGNOSIS >

## DTC Index

INFOID:000000004215478

CONSULT-III display	Fail-safe	TIME <sup>NOTE</sup>		Refer to
No DTC is detected. further testing may be required.	—	—	—	—
U1000: CAN COMM CIRCUIT	×	CRNT	1 – 39	<a href="#">PCS-15</a>

### NOTE:

The details of TIME display are as follows.

- CRNT: The malfunctions that are detected now
- 1 - 39: The number is indicated when it is normal at present and a malfunction was detected in the past. It increases like 0 → 1 → 2 ... 38 → 39 after returning to the normal condition whenever IGN OFF → ON. It is fixed to 39 until the self-diagnosis results are erased if it is over 39. It returns to 0 when a malfunction is detected again in the process.

A  
B  
C  
D  
E  
F  
G  
H  
I  
J  
K  
L  
M

MWI

O  
P

# THE FUEL GAUGE POINTER DOES NOT MOVE

< SYMPTOM DIAGNOSIS >

## SYMPTOM DIAGNOSIS

### THE FUEL GAUGE POINTER DOES NOT MOVE

#### Description

INFOID:000000003790479

Fuel gauge needle will not move from a certain position.

#### Diagnosis Procedure

INFOID:000000003790480

#### 1. CHECK COMBINATION METER INPUT SIGNAL

1. Select "METER/M&A" on CONSULT-III.
2. Using "FUEL METER" of "DATA MONITOR", compare the monitor value with the fuel gauge reading on the combination meter. Refer to [MWI-36, "Component Function Check"](#).

Does monitor value match fuel gauge reading?

YES >> GO TO 2

NO >> Replace combination meter. Refer to [MWI-103, "Removal and Installation"](#).

#### 2. CHECK FUEL LEVEL SENSOR SIGNAL CIRCUIT

Check the fuel level sensor signal circuit. Refer to [MWI-36, "Diagnosis Procedure"](#).

Is the inspection result normal?

YES >> GO TO 3

NO >> Repair harness or connector.

#### 3. CHECK FUEL LEVEL SENSOR UNIT

Perform a unit check for the fuel level sensor unit. Refer to [MWI-37, "Component Inspection"](#).

Is the inspection result normal?

YES >> GO TO 4

NO >> Replace fuel level sensor unit. Refer to [FL-12, "Removal and Installation"](#).

#### 4. CHECK FLOAT INTERFERENCE

Check that the float arm does not interfere or bind with any of the components in the fuel tank.

Is the inspection result normal?

YES >> Replace combination meter. Refer to [MWI-103, "Removal and Installation"](#).

NO >> Repair or replace malfunctioning parts.

# THE FUEL GAUGE POINTER DOES NOT MOVE TO "F" WHEN REFUELING

< SYMPTOM DIAGNOSIS >

## THE FUEL GAUGE POINTER DOES NOT MOVE TO "F" WHEN REFUELING

### Description

INFOID:000000003790481

The fuel gauge needle will not move to "F" position when refueling.

### Diagnosis Procedure

INFOID:000000003790482

#### 1.OBSERVE FUEL GAUGE

Does it take a long time for the pointer to move to FULL position?

YES or NO

YES >> GO TO 2

NO >> GO TO 3

#### 2.IDENTIFY FUELING CONDITION

Was the vehicle fueled with the ignition switch ON?

YES or NO

YES >> Be sure to fuel the vehicle with the ignition switch OFF. Otherwise, it will take a long time to move to FULL position because of the characteristic of the fuel gauge.

NO >> GO TO 3

#### 3.OBSERVE VEHICLE POSITION

Is the vehicle parked on an incline?

YES or NO

YES >> Check the fuel level indication with vehicle on a level surface.

NO >> GO TO 4

#### 4.OBSERVE FUEL GAUGE POINTER

During driving, does the fuel gauge pointer move gradually toward EMPTY position?

YES or NO

YES >> Check the components. Refer to [MWI-37. "Component Inspection"](#).

NO >> The float arm may interfere or bind with any of the components in the fuel tank.

A  
B  
C  
D  
E  
F  
G  
H  
I  
J  
K  
L  
M  
O  
P

MWI

# THE OIL PRESSURE WARNING LAMP DOES NOT TURN ON

< SYMPTOM DIAGNOSIS >

---

## THE OIL PRESSURE WARNING LAMP DOES NOT TURN ON

### Description

INFOID:000000003790483

The oil pressure warning lamp stays off when the ignition switch is turned ON.

### Diagnosis Procedure

INFOID:000000003790484

#### 1. CHECK OIL PRESSURE WARNING LAMP

---

Perform IPDM E/R auto active test. Refer to [PCS-11, "Diagnosis Description"](#).

Is oil pressure warning lamp illuminated?

YES >> GO TO 2

NO >> Replace combination meter. Refer to [MWI-103, "Removal and Installation"](#).

#### 2. CHECK OIL PRESSURE SWITCH SIGNAL CIRCUIT

---

Check the oil pressure switch signal circuit. Refer to [MWI-39, "Diagnosis Procedure"](#).

Is the inspection result normal?

YES >> GO TO 3

NO >> Repair harness or connector.

#### 3. CHECK OIL PRESSURE SWITCH UNIT

---

Perform a unit check for the oil pressure switch. Refer to [MWI-39, "Component Inspection"](#).

Is the inspection result normal?

YES >> Replace IPDM E/R. Refer to [PCS-30, "Removal and Installation of IPDM E/R"](#).

NO >> Replace oil pressure switch.



# THE OIL PRESSURE WARNING LAMP DOES NOT TURN OFF

< SYMPTOM DIAGNOSIS >

## THE OIL PRESSURE WARNING LAMP DOES NOT TURN OFF

### Description

INFOID:000000003790485

The oil pressure warning lamp remains illuminated while the engine is running (normal oil pressure).

### Diagnosis Procedure

INFOID:000000003790486

#### 1. CHECK OIL PRESSURE WARNING LAMP

Perform IPDM E/R auto active test. Refer to [PCS-11, "Diagnosis Description"](#).

Is oil pressure warning lamp illuminated?

YES >> GO TO 2

NO >> Replace combination meter. Refer to [MWI-103, "Removal and Installation"](#).

#### 2. CHECK IPDM E/R OUTPUT VOLTAGE

1. Turn ignition switch OFF.
2. Disconnect the oil pressure switch connector.
3. Turn ignition switch ON.
4. Check voltage between the oil pressure switch harness connector F4 terminal 1 and ground.

**1 – Ground : Approx. 12V**

Is the inspection result normal?

YES >> GO TO 3

NO >> GO TO 4

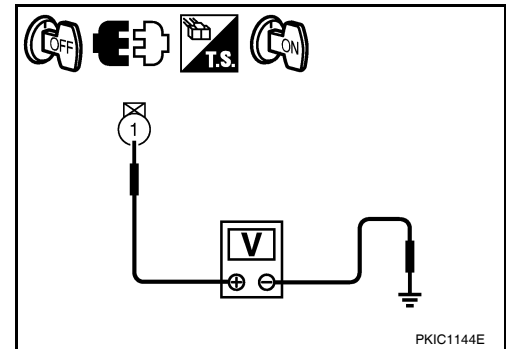

#### 3. CHECK OIL PRESSURE SWITCH

Perform a unit check for the oil pressure switch. Refer to [MWI-39, "Component Inspection"](#).

Is the inspection result normal?

YES >> Replace IPDM E/R. Refer to [PCS-30, "Removal and Installation of IPDM E/R"](#).

NO >> Replace oil pressure switch.

#### 4. CHECK OIL PRESSURE SWITCH SIGNAL CIRCUIT

Check the oil pressure switch signal circuit. Refer to [MWI-39, "Diagnosis Procedure"](#).

Is the inspection result normal?

YES >> Replace IPDM E/R. Refer to [PCS-30, "Removal and Installation of IPDM E/R"](#).

NO >> Repair harness or connector.

A  
B  
C  
D  
E  
F  
G  
H  
I  
J  
K  
L  
M  
O  
P

MWI

# THE PARKING BRAKE RELEASE WARNING CONTINUES DISPLAYING, OR DOES NOT DISPLAY

< SYMPTOM DIAGNOSIS >

## THE PARKING BRAKE RELEASE WARNING CONTINUES DISPLAYING, OR DOES NOT DISPLAY

### Description

INFOID:000000003790487

- The parking brake warning is displayed while driving the vehicle even though the parking brake is released.
- The parking brake warning is not displayed even though driving the vehicle with the parking brake applied.

### Diagnosis Procedure

INFOID:000000003790488

#### 1. CHECK PARKING BRAKE WARNING LAMP OPERATION

1. Start engine.
2. Monitor "BRAKE" warning lamp while applying and releasing the parking brake.

##### **BRAKE warning lamp**

**Parking brake applied : ON**

**Parking brake released : OFF**

Is the inspection result normal?

- YES >> Replace combination meter. Refer to [MWI-103, "Removal and Installation"](#).  
NO >> GO TO 2

#### 2. CHECK PARKING BRAKE SWITCH SIGNAL CIRCUIT

1. Turn ignition switch OFF.
2. Check the parking brake switch signal circuit. Refer to [MWI-40, "Diagnosis Procedure"](#).

Is the inspection result normal?

- YES >> GO TO 3  
NG >> Repair harness or connector.

#### 3. CHECK PARKING BRAKE SWITCH UNIT

Perform a unit check for the parking brake switch. Refer to [MWI-40, "Component Inspection"](#).

Is the inspection result normal?

- YES >> Replace combination meter. Refer to [MWI-103, "Removal and Installation"](#).  
NO >> Replace parking brake switch.

# THE LOW WASHER FLUID WARNING CONTINUES DISPLAYING, OR DOES NOT DISPLAY

< SYMPTOM DIAGNOSIS >

## THE LOW WASHER FLUID WARNING CONTINUES DISPLAYING, OR DOES NOT DISPLAY

### Description

INFOID:000000003790489

- The warning is still displayed even after washer fluid is added.
- The warning is not displayed even though the washer tank is empty.

### Diagnosis Procedure

INFOID:000000003790490

#### 1. CHECK WASHER FLUID LEVEL SWITCH SIGNAL CIRCUIT

Check the washer fluid level switch signal circuit. Refer to [MWI-41. "Diagnosis Procedure"](#).

Is the inspection result normal?

- YES >> GO TO 2
- NO >> Repair harness or connector.

#### 2. CHECK WASHER FLUID LEVEL SWITCH UNIT

Perform a unit check for the washer fluid level switch. Refer to [MWI-41. "Component Inspection"](#).

Is the inspection result normal?

- YES >> Replace combination meter. Refer to [MWI-103. "Removal and Installation"](#).
- NO >> Replace washer level switch.

A  
B  
C  
D  
E  
F  
G  
H  
I  
J  
K  
L  
M  
O  
P

MWI

# THE DOOR OPEN WARNING CONTINUES DISPLAYING, OR DOES NOT DISPLAY

< SYMPTOM DIAGNOSIS >

## THE DOOR OPEN WARNING CONTINUES DISPLAYING, OR DOES NOT DISPLAY

### Description

INFOID:000000003790491

- The door open warning is displayed even though all of the doors are closed.
- The door open warning is not displayed even though a door is open.

### Diagnosis Procedure

INFOID:000000003790492

#### 1.CHECK SELF-DIAGNOSIS OF COMBINATION METER

Select "METER/M&A" on CONSULT-III and perform "SELF-DIAGNOSIS".

Is the inspection result normal?

YES >> GO TO 2

NO >> Refer to [MWI-65. "DTC Index"](#).

#### 2.CHECK SELF-DIAGNOSIS OF BCM

Select "BCM" on CONSULT-III and perform "SELF-DIAGNOSIS".

Is the inspection result normal?

YES >> GO TO 3

NO >> Refer to [BCS-49. "DTC Index"](#).

#### 3.CHECK DOOR SWITCH SIGNAL CIRCUIT

Check the door switch signal circuit. Refer to [DLK-28. "CREW CAB : Diagnosis Procedure"](#) (crew cab) or [DLK-26. "KING CAB : Diagnosis Procedure"](#) (king cab).

Is the inspection result normal?

YES >> Replace combination meter. Refer to [MWI-103. "Removal and Installation"](#).

NO >> Repair or replace malfunctioning parts.

# NORMAL OPERATING CONDITION

< SYMPTOM DIAGNOSIS >

## NORMAL OPERATING CONDITION COMPASS

### COMPASS : Description

INFOID:000000003790493

#### COMPASS

- The electronic compass is highly protected from changes in most magnetic fields. However, some large changes in magnetic fields can affect it. Some examples are (but not limited to): high tension power lines, large steel buildings, subways, steel bridges, automatic car washes, large piles of scrap metal, etc. While this does not happen very often, it is possible.
- During normal operation, the Compass Mirror will continuously update the compass calibration to adjust for gradual changes in the vehicle's magnetic "remnant" field. If the vehicle is subjected to high magnetic influences, the compass may appear to indicate false headings, become locked, or appear that it is unable to be calibrated. If this occurs, perform the calibration procedure.
- If at any time the compass continually displays the incorrect direction or the reading is erratic or locked, verify the correct zone variance.

#### Symptom Chart

Symptom	Cause	Solution / Reference
The compass display reads "C".	<ul style="list-style-type: none"> <li>• Compass is not calibrated.</li> <li>• Incorrect zone variance setting.</li> <li>• Large change in magnetic field (Steel bridges, subways, concentrations of metal, car washes, etc.)</li> <li>• Compass was calibrated incorrectly or in the presence of a strong magnetic field.</li> </ul>	Perform Calibration. Refer to <a href="#">MWI-25, "Description"</a> .
Compass shows the wrong direction.		
Compass does not change direction appears "Locked".		
Compass does not show all the directions, one or more is missing.		
The compass was calibrated but it "loses" calibration.		
On long trips the compass shows the wrong direction.	Perform Zone Variation Setting if correct reading is desired in that location. Refer to <a href="#">MWI-25, "Description"</a> .	

A  
B  
C  
D  
E  
F  
G  
H  
I  
J  
K  
L  
M  
O  
P



# PRECAUTIONS

< PRECAUTION >

## PRECAUTION

### PRECAUTIONS

#### Supplemental Restraint System (SRS) "AIR BAG" and "SEAT BELT PRE-TENSIONER"

INFOID:000000003790494

The Supplemental Restraint System such as "AIR BAG" and "SEAT BELT PRE-TENSIONER", used along with a front seat belt, helps to reduce the risk or severity of injury to the driver and front passenger for certain types of collision. This system includes seat belt switch inputs and dual stage front air bag modules. The SRS system uses the seat belt switches to determine the front air bag deployment, and may only deploy one front air bag, depending on the severity of a collision and whether the front occupants are belted or unbelted. Information necessary to service the system safely is included in the SR and SB section of this Service Manual.

**WARNING:**

- To avoid rendering the SRS inoperative, which could increase the risk of personal injury or death in the event of a collision which would result in air bag inflation, all maintenance must be performed by an authorized NISSAN/INFINITI dealer.
- Improper maintenance, including incorrect removal and installation of the SRS, can lead to personal injury caused by unintentional activation of the system. For removal of Spiral Cable and Air Bag Module, see the SR section.
- Do not use electrical test equipment on any circuit related to the SRS unless instructed to in this Service Manual. SRS wiring harnesses can be identified by yellow and/or orange harnesses or harness connectors.

# COMBINATION METERS

< ON-VEHICLE REPAIR >

## ON-VEHICLE REPAIR

### COMBINATION METERS

#### Removal and Installation

INFOID:000000003790495

#### REMOVAL

1. Disconnect battery negative terminal.
2. Remove the cluster lid A. Refer to [IP-12, "Removal and Installation"](#).
3. Remove the combination meter lower screws (A), using power tool.

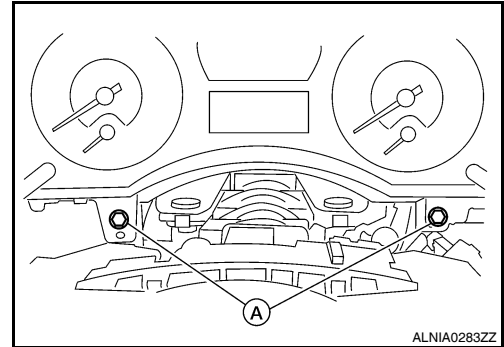

4. Remove the combination meter upper screws (A) using power tool, and pull out the combination meter (1).
5. Disconnect the combination meter connectors, and remove the combination meter (1).

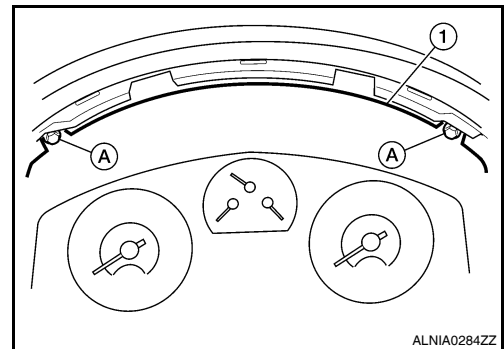

#### INSTALLATION

Installation is the reverse order of removal.

A  
B  
C  
D  
E  
F  
G  
H  
I  
J  
K  
L  
M  
O  
P

MWI

# COMBINATION METERS

< DISASSEMBLY AND ASSEMBLY >

## DISASSEMBLY AND ASSEMBLY

### COMBINATION METERS

#### Removal and Installation

INFOID:000000003790496

#### Disassembly and Assembly

##### Disassembly

1. Disconnect battery negative terminal.
2. Remove the cluster lid A. Refer to [IP-12. "Removal and Installation"](#).
3. Disengage the tabs to separate front cover (1), from the unified meter control unit assembly (2).

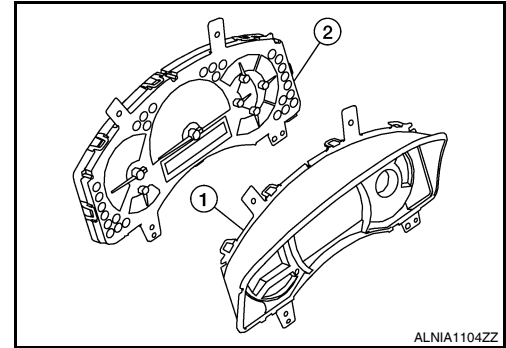

ALNIA1104ZZ

##### Assembly

Assembly is in the reverse order of disassembly.