

A
B
C
D
E
F
G
H
I
J
K

DI

SECTION

DRIVER INFORMATION SYSTEM

CONTENTS

<p>PRECAUTION 3</p> <p style="padding-left: 20px;">Precautions for Supplemental Restraint System (SRS) "AIR BAG" and "SEAT BELT PRE-TENSIONER" 3</p> <p>PREPARATION 4</p> <p style="padding-left: 20px;">Commercial Service Tool 4</p> <p>COMBINATION METERS 5</p> <p style="padding-left: 20px;">Component Parts and Harness Connector Location... 5</p> <p style="padding-left: 20px;">System Description 5</p> <p style="padding-left: 40px;">UNIFIED METER CONTROL UNIT 5</p> <p style="padding-left: 40px;">POWER SUPPLY AND GROUND CIRCUIT 5</p> <p style="padding-left: 40px;">SPEEDOMETER 6</p> <p style="padding-left: 40px;">TACHOMETER 6</p> <p style="padding-left: 40px;">FUEL GAUGE 6</p> <p style="padding-left: 40px;">ODO/TRIP METER 6</p> <p style="padding-left: 40px;">CAN COMMUNICATION SYSTEM DESCRIPTION 6</p> <p style="padding-left: 20px;">Arrangement of Combination Meter 7</p> <p style="padding-left: 20px;">Internal Circuit 8</p> <p style="padding-left: 20px;">Wiring Diagram — METER — 9</p> <p style="padding-left: 20px;">Combination Meter Harness Connector Terminal Layout 11</p> <p style="padding-left: 20px;">Terminals and Reference Value for Combination Meter 11</p> <p style="padding-left: 20px;">Self-Diagnosis Mode of Combination Meter 13</p> <p style="padding-left: 40px;">SELF-DIAGNOSIS MODE FUNCTION 13</p> <p style="padding-left: 40px;">OPERATION PROCEDURE 13</p> <p style="padding-left: 20px;">CONSULT-II Function (METER) 14</p> <p style="padding-left: 40px;">CONSULT-II START PROCEDURE 14</p> <p style="padding-left: 40px;">SELF-DIAGNOSTIC RESULTS 14</p> <p style="padding-left: 40px;">DATA MONITOR 15</p> <p style="padding-left: 20px;">Trouble Diagnosis 17</p> <p style="padding-left: 40px;">HOW TO PERFORM TROUBLE DIAGNOSIS ... 17</p> <p style="padding-left: 40px;">PRELIMINARY CHECK 17</p> <p style="padding-left: 20px;">Symptom Chart 17</p> <p style="padding-left: 20px;">Power Supply and Ground Circuit Inspection 17</p> <p style="padding-left: 20px;">Vehicle Speed Signal Inspection 18</p> <p style="padding-left: 40px;">WITH ABS 18</p> <p style="padding-left: 40px;">WITHOUT ABS OR CVT 19</p> <p style="padding-left: 40px;">WITH CVT, WITHOUT ABS 19</p>	<p style="padding-left: 20px;">Engine Speed Signal Inspection 20</p> <p style="padding-left: 20px;">Fuel Level Sensor Signal Inspection 20</p> <p style="padding-left: 20px;">Fuel Gauge Fluctuates, Indicates Wrong Value, or Varies 22</p> <p style="padding-left: 20px;">Fuel Gauge Does Not Move to Full position 22</p> <p style="padding-left: 20px;">DTC [U1000] CAN Communication Circuit 22</p> <p style="padding-left: 20px;">Electrical Components Inspection 23</p> <p style="padding-left: 40px;">FUEL LEVEL SENSOR UNIT CHECK 23</p> <p style="padding-left: 20px;">Removal and Installation 23</p> <p style="padding-left: 40px;">COMBINATION METER 23</p> <p>WARNING LAMPS 24</p> <p style="padding-left: 20px;">Schematic 24</p> <p style="padding-left: 20px;">Wiring Diagram — WARN — 25</p> <p style="padding-left: 20px;">Oil Pressure Warning Lamp Stays Off (Ignition Switch ON) 34</p> <p style="padding-left: 20px;">Oil Pressure Warning Lamp Does Not Turn Off (Oil Pressure Is Normal) 35</p> <p style="padding-left: 20px;">Component Inspection 36</p> <p style="padding-left: 40px;">OIL PRESSURE SWITCH 36</p> <p>A/T INDICATOR 37</p> <p style="padding-left: 20px;">System Description 37</p> <p style="padding-left: 20px;">Wiring Diagram — AT/IND — 38</p> <p style="padding-left: 20px;">A/T Indicator Does Not Illuminate 40</p> <p>CVT INDICATOR 42</p> <p style="padding-left: 20px;">System Description 42</p> <p style="padding-left: 20px;">Wiring Diagram — CVTIND — 43</p> <p style="padding-left: 20px;">CVT Indicator Does Not Illuminate 45</p> <p>WARNING CHIME 47</p> <p style="padding-left: 20px;">Component Parts and Harness Connector Location.. 47</p> <p style="padding-left: 20px;">System Description 47</p> <p style="padding-left: 40px;">POWER SUPPLY AND GROUND CIRCUIT 47</p> <p style="padding-left: 40px;">IGNITION KEY WARNING CHIME (WITHOUT INTELLIGENT KEY) 48</p> <p style="padding-left: 40px;">IGNITION KEY WARNING CHIME (WITH INTELLIGENT KEY) 48</p> <p style="padding-left: 40px;">LIGHT WARNING CHIME 48</p> <p style="padding-left: 20px;">Wiring Diagram — CHIME — 50</p> <p style="padding-left: 20px;">Terminals and Reference Values for BCM 52</p> <p style="padding-left: 20px;">CONSULT-II Function (BCM) 52</p> <p style="padding-left: 40px;">CONSULT-II START PROCEDURE 52</p>
--	--

DATA MONITOR	52	Key Switch Signal Inspection (Without Intelligent	
ACTIVE TEST	52	Key)	56
SELF-DIAG RESULTS	52	Key Switch and Ignition Knob Switch Signal Inspec-	
Trouble Diagnosis	53	tion (With Intelligent Key, When Mechanical Key Is	
HOW TO PERFORM TROUBLE DIAGNOSIS ...	53	Used)	58
PRELIMINARY INSPECTION	53	Lighting Switch Signal Inspection	59
SYMPTOM CHART	53	Electrical Component Inspection	60
Combination Meter Buzzer Circuit Inspection	54	FRONT DOOR SWITCH LH	60
Front Door Switch LH Signal Inspection	55		

PRECAUTION

PRECAUTION

PFP:00011

Precautions for Supplemental Restraint System (SRS) “AIR BAG” and “SEAT BELT PRE-TENSIONER”

EKS0019C

The Supplemental Restraint System such as “AIR BAG” and “SEAT BELT PRE-TENSIONER”, used along with a front seat belt, helps to reduce the risk or severity of injury to the driver and front passenger for certain types of collision. This system includes seat belt switch inputs and dual stage front air bag modules. The SRS system uses the seat belt switches to determine the front air bag deployment, and may only deploy one front air bag, depending on the severity of a collision and whether the front occupants are belted or unbelted. Information necessary to service the system safely is included in the SRS and SB section of this Service Manual.

WARNING:

- To avoid rendering the SRS inoperative, which could increase the risk of personal injury or death in the event of a collision which would result in air bag inflation, all maintenance must be performed by an authorized NISSAN/INFINITI dealer.
- Improper maintenance, including incorrect removal and installation of the SRS, can lead to personal injury caused by unintentional activation of the system. For removal of Spiral Cable and Air Bag Module, see the SRS section.
- Do not use electrical test equipment on any circuit related to the SRS unless instructed to in this Service Manual. SRS wiring harnesses can be identified by yellow and/or orange harnesses or harness connectors.

A
B
C
D
E
F
G
H
I
J
L
M

DI

PREPARATION

PREPARATION

PF0:00002

Commercial Service Tool

EKS00198

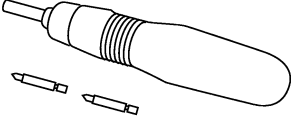
Tool name	Description
<p data-bbox="162 298 272 323">Power tool</p>  <p data-bbox="852 499 925 514">PBIC0191E</p>	<p data-bbox="1015 298 1266 323">Loosening bolts and nuts</p>

COMBINATION METERS

PFP:24814

COMBINATION METERS

Component Parts and Harness Connector Location

EKS001AP

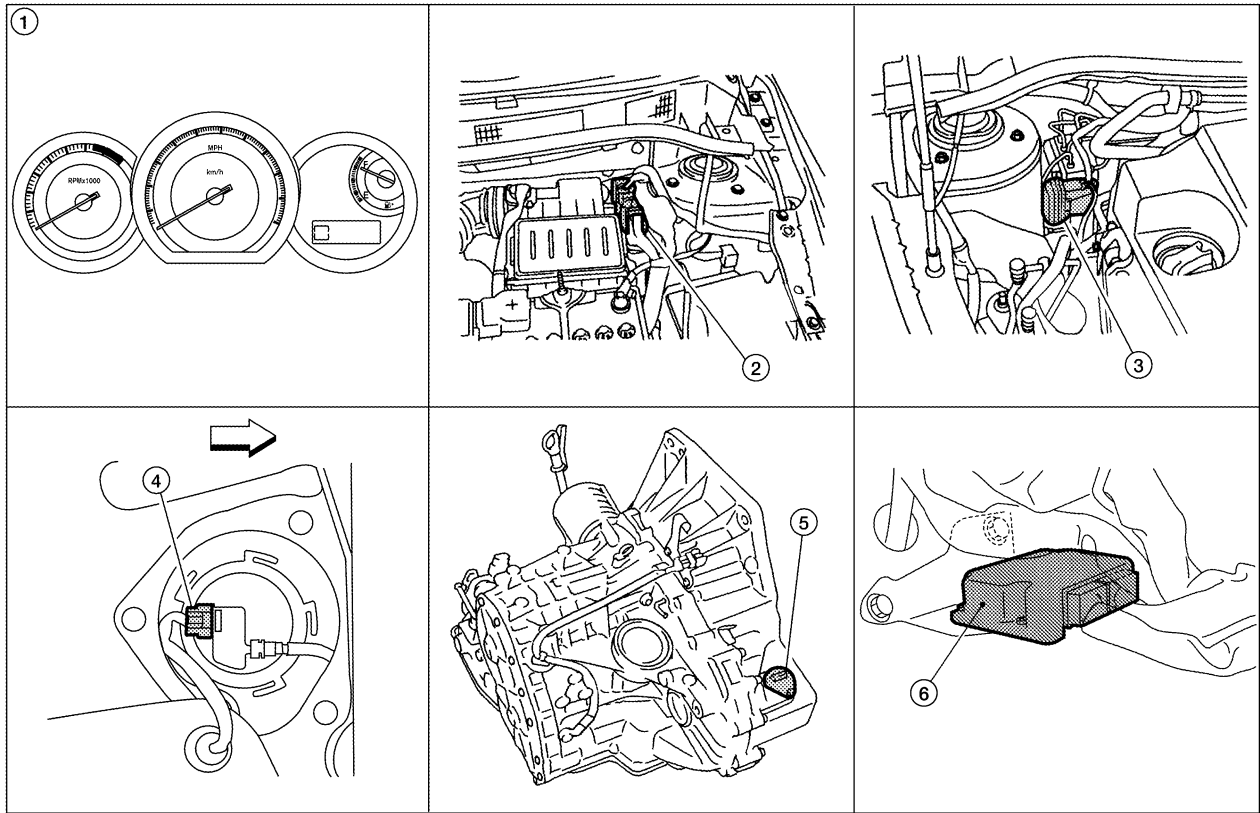

WKIA5450E

1. Combination meter M24
2. ECM E16
3. ABS actuator and electric unit (control unit) E33
4. Fuel level sensor unit and fuel pump (fuel level sensor) B100 (view with rear seat and inspection hole cover removed)
(←: Front)
5. Vehicle speed sensor F41 (A/T shown, M/T similar)
6. TCM E31 (view with instrument lower finisher removed)

System Description UNIFIED METER CONTROL UNIT

EKS00105

- Speedometer, odo/trip meter, tachometer and fuel gauge are controlled by the unified meter control unit, which is built into the combination meter.
- Warning and indicator lamps are controlled by signals drawn from the CAN communication system, BCM (body control module), and components connected directly to the combination meter.
- Odo/trip meter and A/T indicator (with A/T) or CVT indicator (with CVT) segments can be checked in self-diagnosis mode.
- Meters/gauges can be checked in self-diagnosis mode.

POWER SUPPLY AND GROUND CIRCUIT

Power is supplied at all times

- through 10A fuse [No. 13, located in the fuse block (J/B)]
- to combination meter terminal 27.

With the ignition switch in the ON or START position, power is supplied

- through 10A fuse [No. 14, located in the fuse block (J/B)]
- to combination meter terminal 28.

Ground is supplied

- to combination meter terminals 21, 22 and 23

COMBINATION METERS

- through grounds M57 and M61.

SPEEDOMETER

With ABS

The ABS actuator and electric unit (control unit) provides a vehicle speed signal to the combination meter via CAN communication lines.

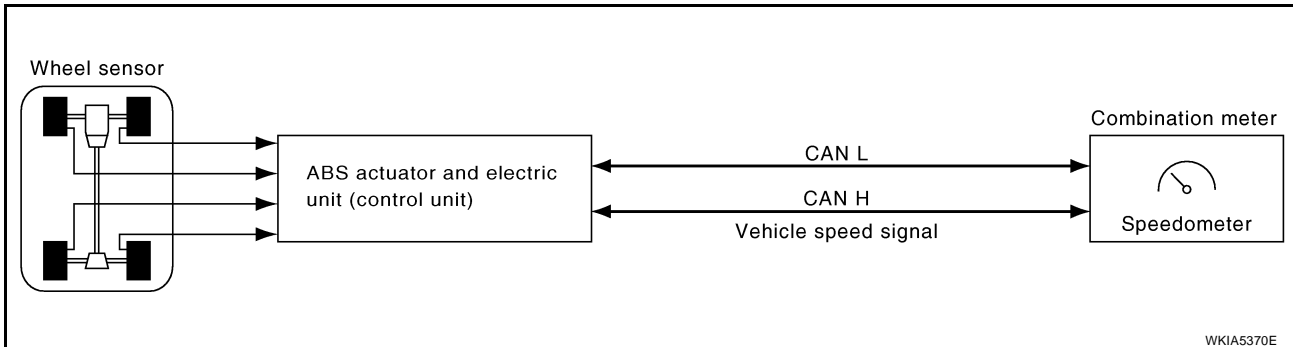

Without ABS or CVT

The vehicle speed sensor provides a vehicle speed signal to the combination meter for speedometer indication.

With CVT, Without ABS

The TCM provides a vehicle speed signal to the combination meter via CAN communication lines.

TACHOMETER

The tachometer indicates engine speed in revolutions per minute (rpm). The ECM provides an engine speed signal to combination meter via CAN communication lines.

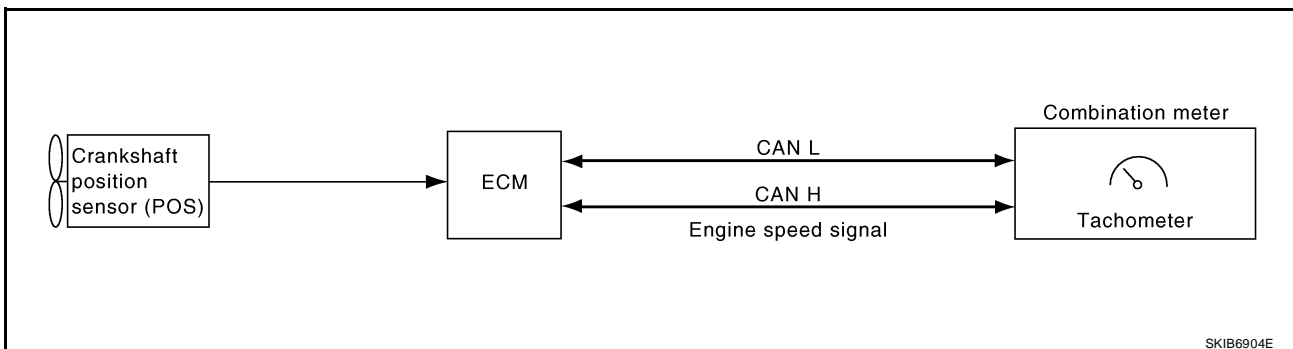

FUEL GAUGE

The fuel gauge indicates the approximate fuel level in the fuel tank.

The fuel gauge is regulated by the unified meter control unit and a variable resistor signal supplied

- to combination meter terminal 24
- through fuel level sensor unit and fuel pump terminal 5
- through fuel level sensor unit and fuel pump terminal 2
- from combination meter terminal 6.

ODO/TRIP METER

The vehicle speed signal and the memory signals from the meter memory circuit are processed by the combination meter and the mileage is displayed.

How to Change the Display

Refer to Owner's Manual for odo/trip meter operating instructions.

CAN COMMUNICATION SYSTEM DESCRIPTION

Refer to [LAN-4, "SYSTEM DESCRIPTION"](#) .

COMBINATION METERS

Arrangement of Combination Meter

EKS00107

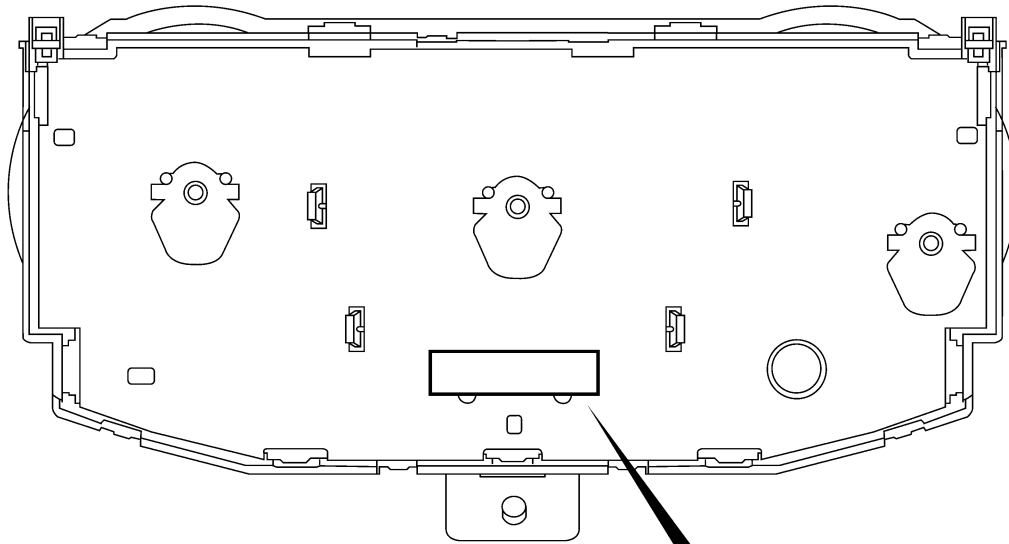
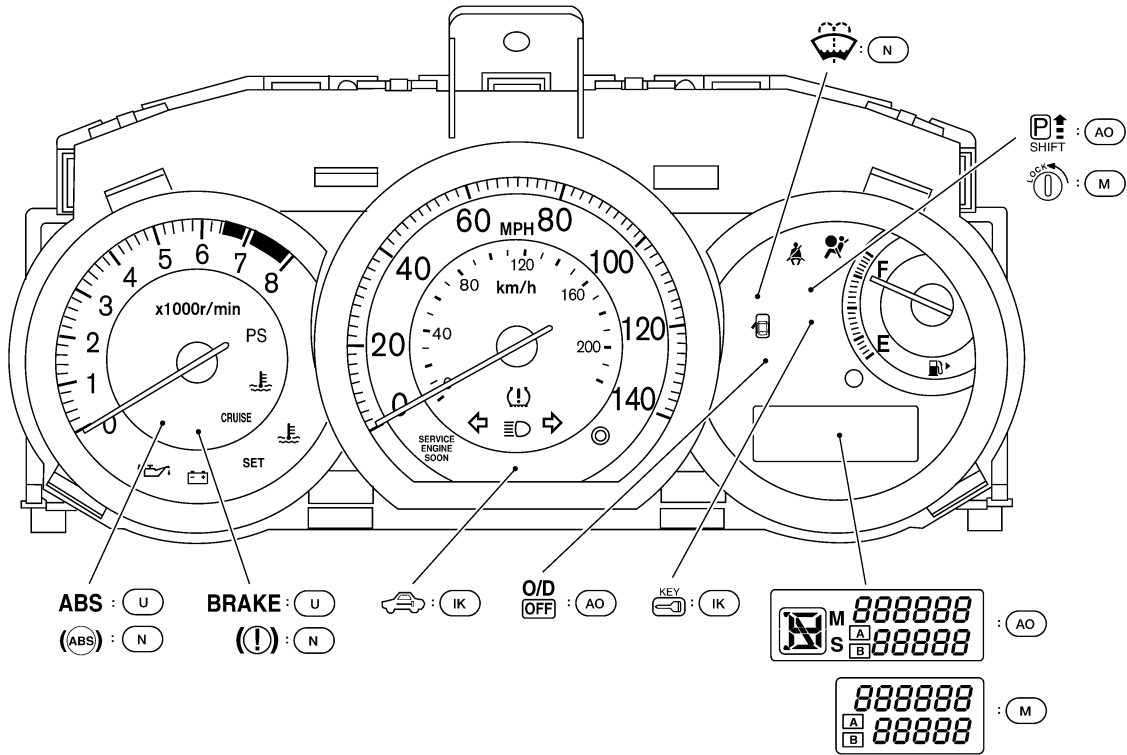

- (AO) : WITH A/T OR CVT
- (IK) : WITH INTELLIGENT KEY
- (M) : WITH M/T
- (N) : CANADA
- (U) : USA

20	19	18	17	16	15	14	13	12	11	10	9	8	7	6	5	4	3	2	1
40	39	38	37	36	35	34	33	32	31	30	29	28	27	26	25	24	23	22	21

A
B
C
D
E
F
G
H
I
J
DI
L
M

COMBINATION METERS

EKS00108

Internal Circuit

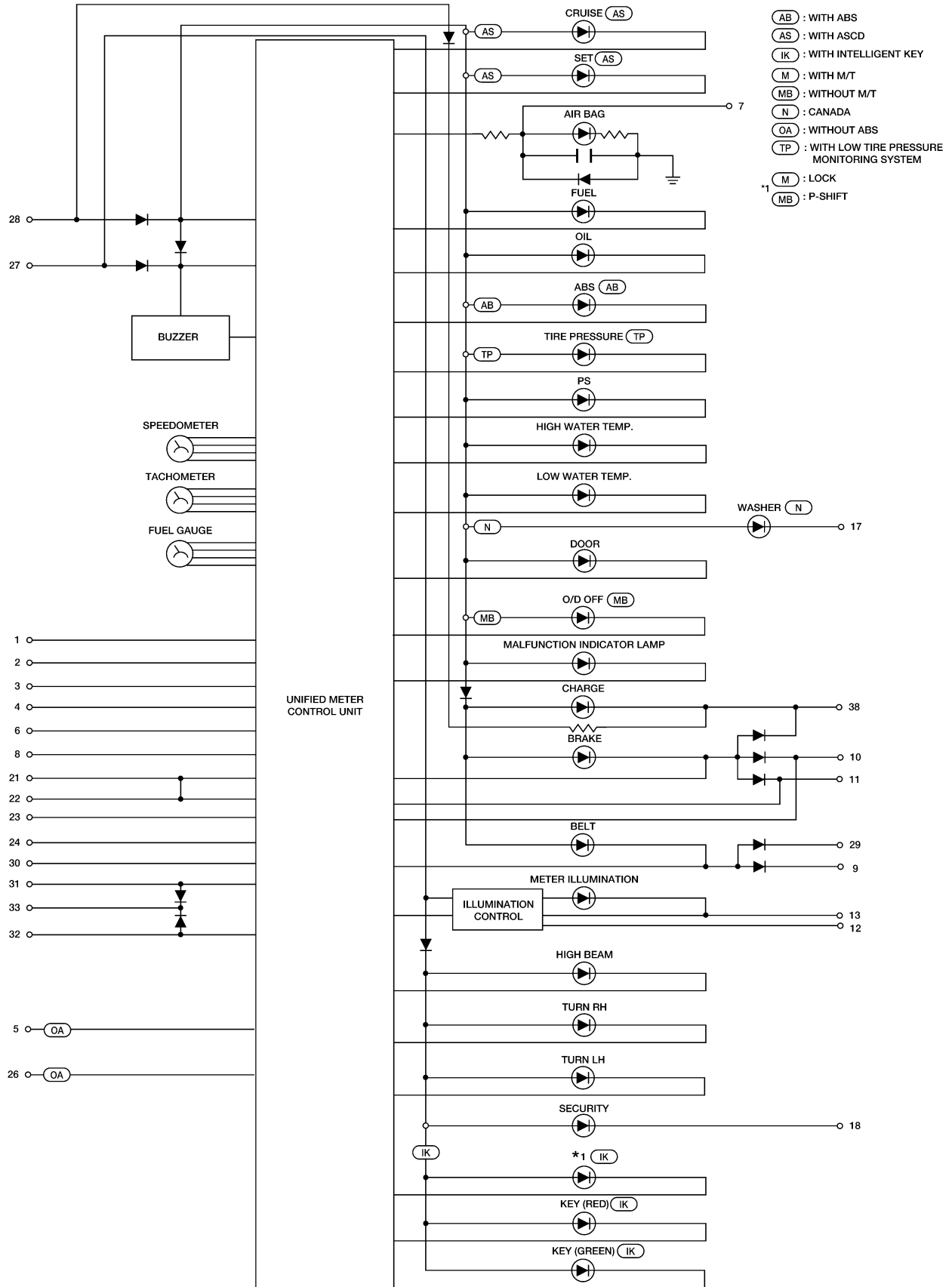

LKWA0348E

COMBINATION METERS

EKS00109

Wiring Diagram — METER —

DI-METER-01

- : DATA LINE
- AB : WITH ABS
- OV : WITHOUT ABS OR CVT
- VB : WITH CVT OR ABS
- VU : WITH CVT WITHOUT ABS

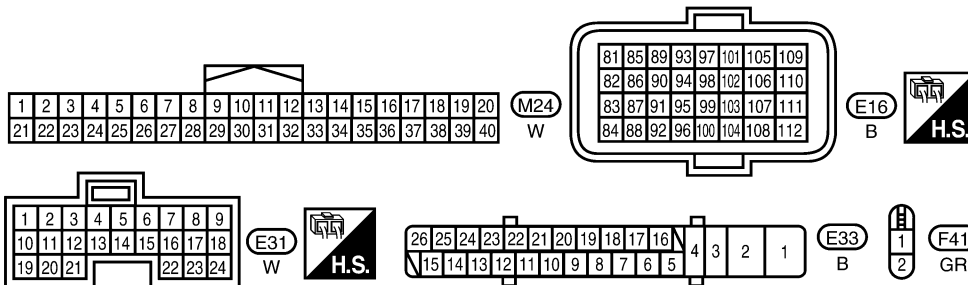
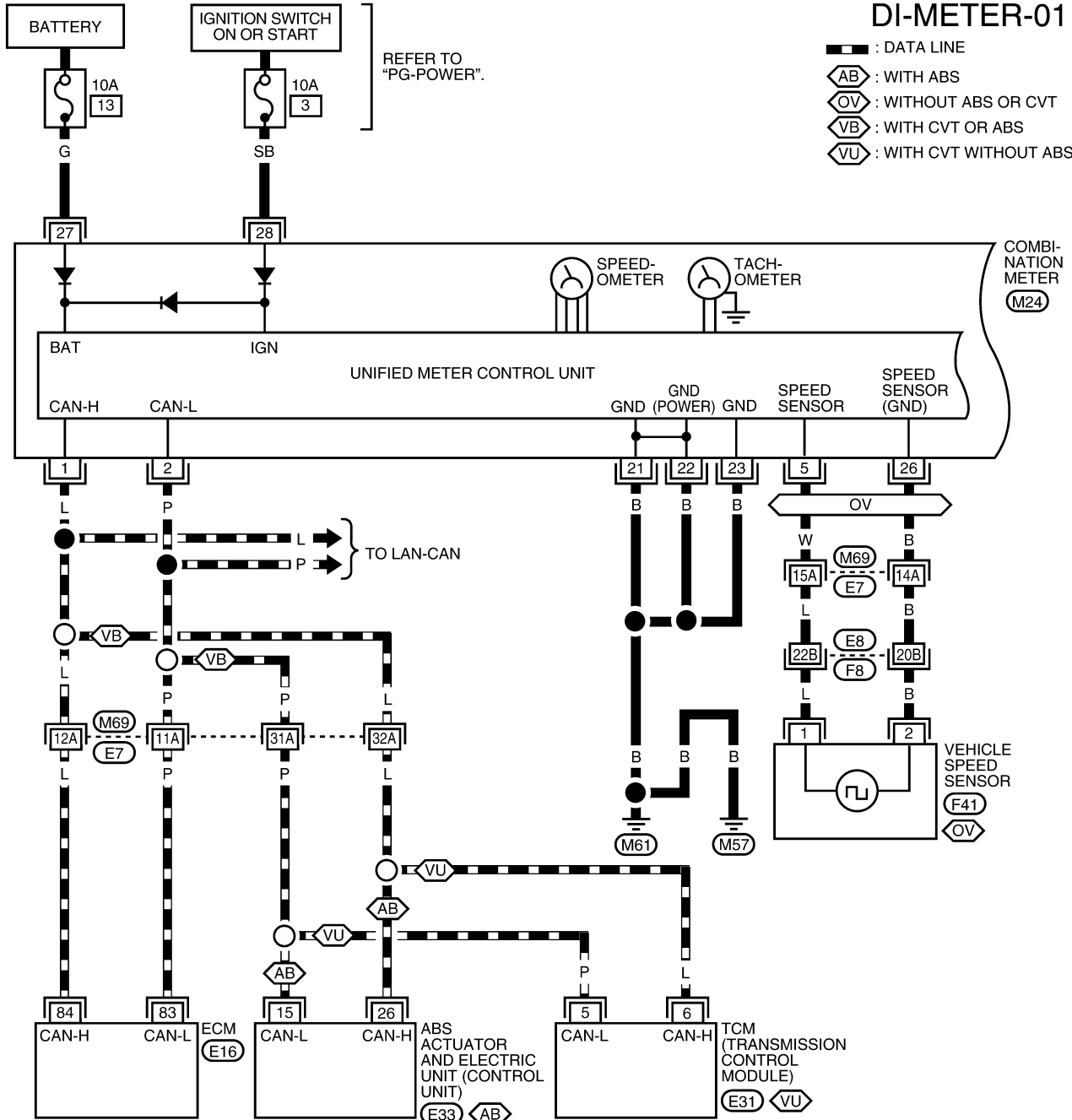

REFER TO THE FOLLOWING.
 M69, F8 - SUPER MULTIPLE JUNCTION (SMJ)

LKWA0349E

COMBINATION METERS

DI-METER-02

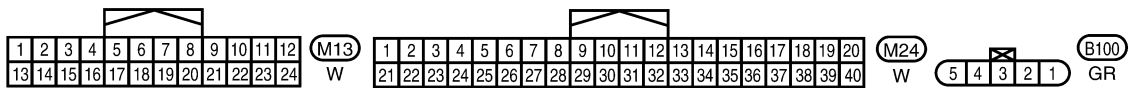
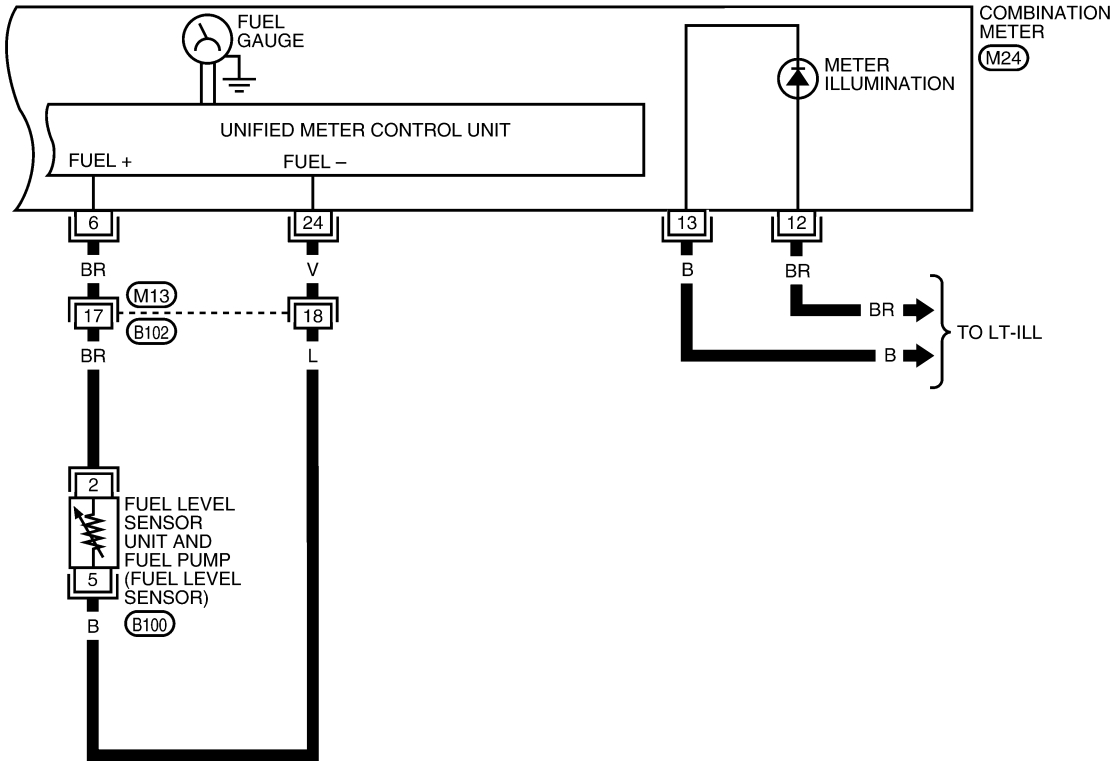

WKWA4989E

COMBINATION METERS

Combination Meter Harness Connector Terminal Layout

EKS0010A

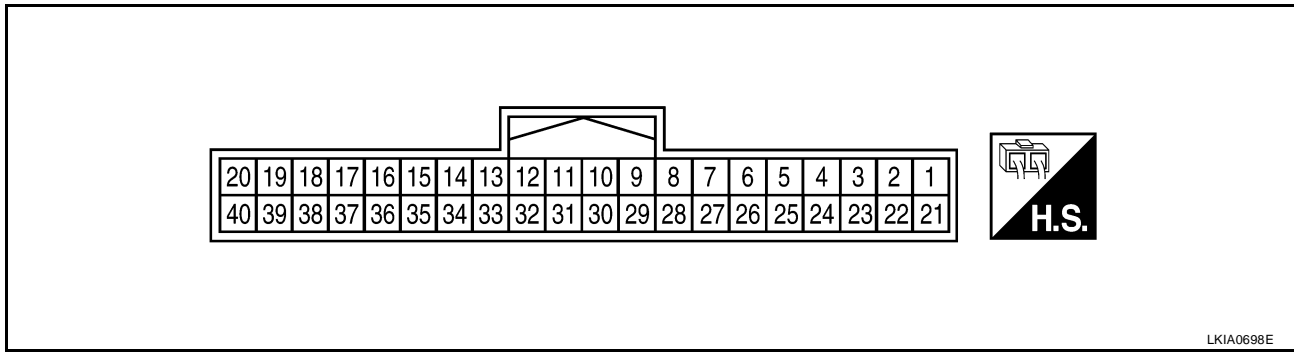

Terminals and Reference Value for Combination Meter

EKS0010A

Terminal No.	Wire color	Item	Condition		Reference value (V) (Approx.)
			Ignition switch	Operation or condition	
1	L	CAN-H	—	—	—
2	P	CAN-L	—	—	—
3	G	Vehicle speed signal output (2-pulse)	ON	Speedometer operated [When vehicle speed is approx. 40 km/h (25 MPH)]	NOTE: Maximum voltage may be 5 V due to specifications (connected units). <small>PKIC0642E</small>
4	SB	Vehicle speed signal output (8-pulse)	ON	Speedometer operated [When vehicle speed is approx. 40 km/h (25 MPH)]	NOTE: Maximum voltage may be 12 V due to specifications (connected units). <small>PKIC0643E</small>
5	W	Vehicle speed signal (without ABS or CVT)	ON	Speedometer operated [When vehicle speed is approx. 20 km/h (12 MPH)]	240 Hz
6	BR	Fuel level sensor signal (+)	—	—	Refer to DI-23, "FUEL LEVEL SENSOR UNIT CHECK" .
8	P	O/D OFF switch	ON	O/D OFF switch pressed	0
				O/D OFF switch released	Battery voltage
9	Y	Seat belt buckle switch LH	ON	Unfastened (ON)	0
				Fastened (OFF)	Battery voltage
10	SB	Parking Brake switch	ON	Parking brake applied	0
				Parking brake released	Battery voltage
11	LG	Brake fluid level switch	ON	Brake fluid level low	0
				Brake fluid level normal	Battery voltage
12	BR	Illumination control switch (+)	—	—	Refer to LT-111, "ILLUMINATION OPERATION BY LIGHTING SWITCH"

COMBINATION METERS

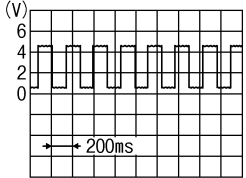
Terminal No.	Wire color	Item	Condition		Reference value (V) (Approx.)
			Ignition switch	Operation or condition	
13	B	Illumination control switch (-)	—	—	Refer to LT-111, "ILLUMINATION OPERATION BY LIGHTING SWITCH"
17	G	Washer fluid level switch (Canada models)	ON	Washer fluid level low	0
				Washer fluid level normal	Battery voltage
21	B	Ground	—	—	0
22					
23					
24	V	Fuel level sensor ground (-)	ON	—	0
26	B	Vehicle speed sensor ground (without ABS or CVT)	ON	—	0
27	G	Battery power supply	OFF	—	Battery voltage
28	SB	Ignition switch ON or START	ON	—	Battery voltage
29	GR	Seat belt buckle switch RH	ON	Unfastened (ON)	0
				Fastened (OFF)	Battery voltage
30	G	Stop lamp switch	ON	Brake pedal depressed	Battery voltage
				Brake pedal released	0
31	V	A/T N-range input (with A/T)	ON	Transmission gear selector lever in N position	Battery voltage
				Transmission gear selector lever other than N position	0
32	W	A/T P-range input (with A/T)	ON	Transmission gear selector lever in P position	Battery voltage
				Transmission gear selector lever other than P position	0
33	Y	A/T PN output (with A/T)	ON	Transmission gear selector lever in P or N position	0
				Transmission gear selector lever other than P or N position	Battery voltage
35	BR	Engine coolant temperature signal output	ON	At idle [after warming up, approx. 80°C (176°F)] NOTE: The waveforms vary depending on engine coolant temperature.	 <p style="text-align: right; font-size: small;">SKIB3651J</p>
38	L	Generator	ON	Generator voltage low	0
				Generator voltage normal	Battery voltage

COMBINATION METERS

EKS0010B

Self-Diagnosis Mode of Combination Meter

SELF-DIAGNOSIS MODE FUNCTION

- Self-diagnosis can check for continuity between meter control circuit and each meter (speedometer, tachometer and fuel gauge).
- Self-diagnosis can check for odo/trip meter and A/T indicator (with A/T) or CVT indicator (with CVT) segment, low-fuel level warning lamp, low water temperature indicator lamp, and high water temperature warning lamp.

OPERATION PROCEDURE

1. Turn the ignition switch ON, and switch the odo/trip meter to “trip A” or “trip B”.

NOTE:

If the diagnosis function is activated with “trip A” displayed, the mileage on “trip A” will indicate “0000.0”, but the actual trip mileage will be retained. (The same applies for “trip B”.)

2. Turn ignition switch OFF.
3. While pushing the odo/trip meter switch (1), turn the ignition switch ON.
4. Confirm that the trip meter displays “0000.0”.
5. Push the odo/trip meter switch at least 3 times. (Within 7 seconds after the ignition switch is turned ON.)

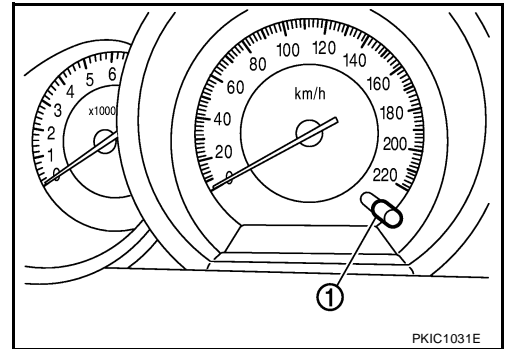

6. All the segments on the odo/trip meter, and simultaneously the low-fuel warning lamp indicator illuminates. At this time, the unified meter control unit is turned to self-diagnosis mode.
 - M/T MODELS (1)
 - A/T AND CVT MODELS (2)

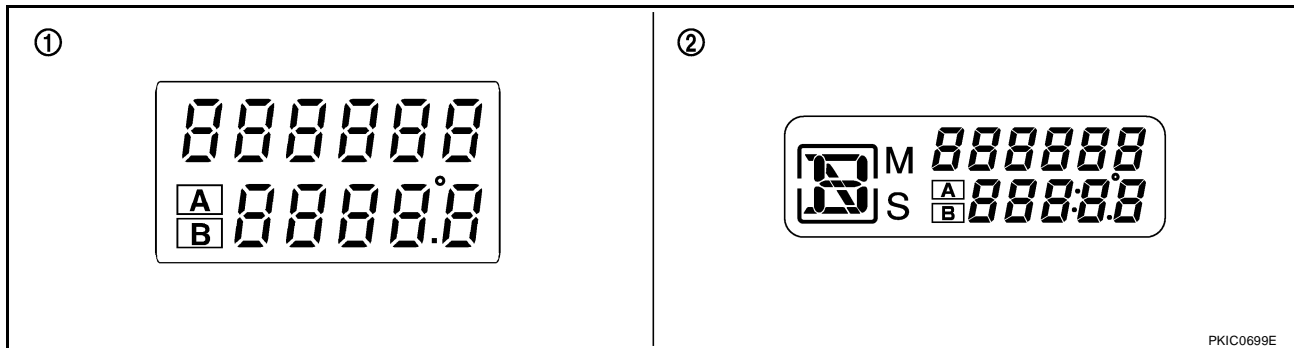

NOTE:

- Check combination meter power supply and ground circuit when self-diagnosis mode of combination meter does not start. Replace combination meter if normal. Refer to [IP-19, "COMBINATION METER"](#) .
- If any of the segments is not displayed, replace combination meter. Refer to [IP-19, "COMBINATION METER"](#) .

COMBINATION METERS

7. Each meter activates while pressing odo/trip meter switch. (At this time, the low-fuel warning lamp turns off, low water temperature indicator lamp and high water temperature warning lamp turn on.)

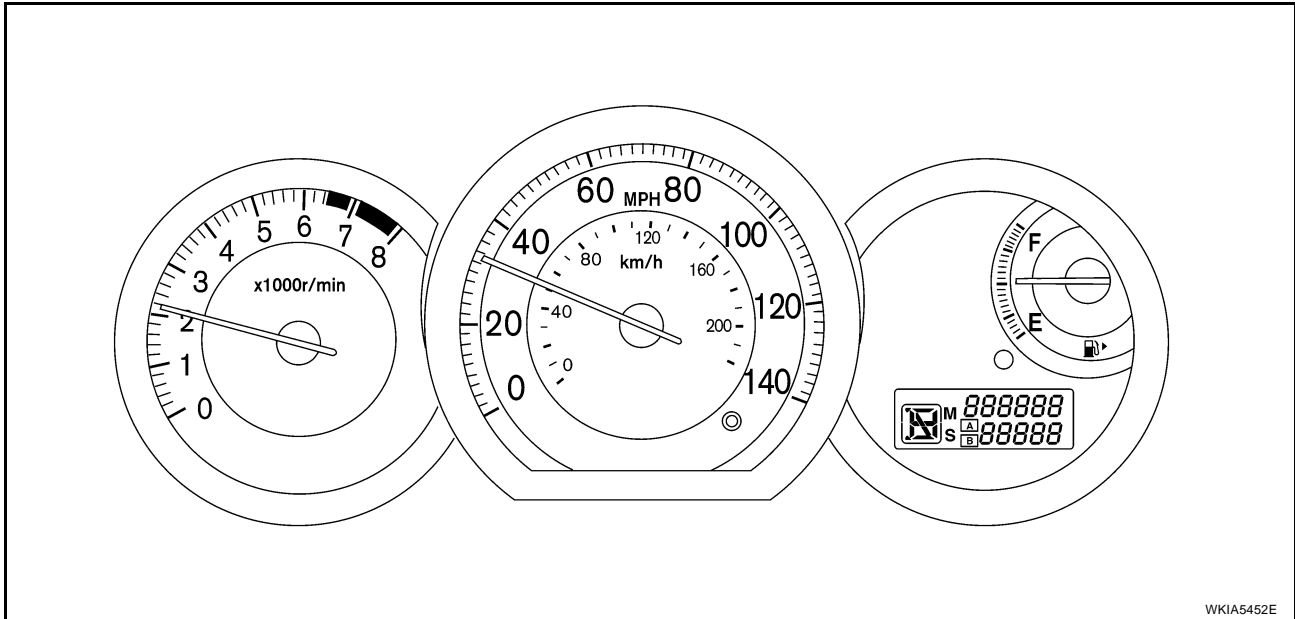

NOTE:

If any of the meter and gages are not activated, replace combination meter. Refer to [IP-19, "COMBINATION METER"](#) .

CONSULT-II Function (METER)

EKS0010C

CONSULT-II can display each diagnostic item using the diagnostic test modes shown following.

METER diagnosis mode	Description
SELF-DIAG RESULTS	Displays combination meter self-diagnosis results.
DATA MONITOR	Displays combination meter input/output data in real time.
CAN DIAG SUPPORT MNTR	The result of transmit/receive diagnosis of CAN communication can be read.

CONSULT-II START PROCEDURE

Refer to [GI-38, "CONSULT-II Start Procedure"](#) .

SELF-DIAGNOSTIC RESULTS

Display Item List

CONSULT-II display	Malfunction	Reference page
CAN COMM CIRC [U1000]	Malfunction is detected in CAN communication lines. CAUTION: Even when there is no malfunction on CAN communication system, malfunction may be misinterpreted when battery has low voltage (when maintaining 7 - 8 V for about 2 seconds) or 10A fuse [No. 14, located in the fuse block (J/B)] is removed.	DI-22
VEHICLE SPEED CIRC [B2205]	Malfunction is detected when an erroneous speed signal is input. CAUTION: Even when there is no malfunction on speed signal system, malfunctions may be misinterpreted when battery has low voltage (when maintaining 7 - 8 V for about 2 seconds).	DI-18

NOTE:

"TIME" indicates the following.

- 0: Indicates that a malfunction is detected at present.
- 1-63: Indicates that a malfunction was detected in the past. (Displays number of ignition switch OFF → ON cycles after malfunction is detected. Self-diagnostic result is erased when "63" is exceeded.)

COMBINATION METERS

DATA MONITOR Display Item List

Display item [Unit]	MAIN SIGNALS	SELECTION FROM MENU	Contents
SPEED METER [km/h]	X	X	The value of vehicle speed signal, which is input from ABS actuator and electric unit (control unit).
SPEED OUTPUT [km/h]	X	X	The value of vehicle speed signal, which is transmitted to each unit with CAN communication.
TACHO METER [rpm]	X	X	The value of engine speed signal, which is input from ECM.
W TEMP METER [°C]	X	X	The value of engine coolant temperature signal, which is input from ECM.
FUEL METER [lit.]	X	X	The value, which processes a resistance signal from fuel gauge.
DISTANCE [km]	X	X	The value, which is calculated by vehicle speed signal from ABS actuator and electric unit (control unit), fuel gauge and fuel consumption signal from ECM.
FUEL W/L [ON/OFF]	X	X	Indicates [ON/OFF] condition of low-fuel warning lamp.
C-ENG W/L [ON/OFF]		X	Indicates [ON/OFF] condition of malfunction indicator lamp (MIL).
AIR PRES W/L		X	Indicates [ON/OFF] condition of low tire pressure warning lamp.
SEAT BELT W/L		X	Indicates [ON/OFF] condition of seat belt warning lamp.
BUZZER [ON/OFF]	X	X	Indicates [ON/OFF] condition of buzzer.
DOOR W/L [ON/OFF]		X	Indicates [ON/OFF] condition of door warning lamp.
HI-BEAM IND [ON/OFF]		X	Indicates [ON/OFF] condition of high beam indicator lamp.
TURN IND [ON/OFF]		X	Indicates [ON/OFF] condition of turn indicator.
OIL W/L [ON/OFF]		X	Indicates [ON/OFF] condition of oil pressure warning lamp.
ABS W/L [ON/OFF]		X	Indicates [ON/OFF] condition of ABS warning lamp.
BRAKE W/L [ON/OFF]		X	Indicates [ON/OFF] condition of brake warning lamp.*
KEY G W/L [ON/OFF]		X	Indicates [ON/OFF] condition of KEY warning lamp (green).
KEY R W/L [ON/OFF]		X	Indicates [ON/OFF] condition of KEY warning lamp (red).
KEY KNOB W/L [ON/OFF]		X	Indicates [ON/OFF] condition of LOCK warning lamp.
PNP P SW [ON/OFF]	X	X	Indicates [ON/OFF] condition of inhibitor P switch.
PNP N SW [ON/OFF]	X	X	Indicates [ON/OFF] condition of inhibitor N switch.
O/D OFF SW [ON/OFF]		X	Indicates [ON/OFF] condition of O/D OFF switch.
BRAKE SW [ON/OFF]		X	Indicates [ON/OFF] condition of parking brake switch.
P RANGE IND [ON/OFF]	X	X	Indicates [ON/OFF] condition of A/T or CVT shift P range indicator.
R RANGE IND [ON/OFF]	X	X	Indicates [ON/OFF] condition of A/T or CVT shift R range indicator.
N RANGE IND [ON/OFF]	X	X	Indicates [ON/OFF] condition of A/T or CVT shift N range indicator.
D RANGE IND [ON/OFF]	X	X	Indicates [ON/OFF] condition of A/T or CVT shift D range indicator.
2 RANGE IND [ON/OFF]	X	X	Indicates [ON/OFF] condition of A/T shift 2 range indicator.
L RANGE IND [ON/OFF]	X	X	Indicates [ON/OFF] condition of CVT shift L range indicator.
1 RANGE IND [ON/OFF]	X	X	Indicates [ON/OFF] condition of A/T shift 1 range indicator.
CRUISE IND [ON/OFF]		X	Indicates [ON/OFF] condition of CRUISE indicator.
SET IND [ON/OFF]		X	Indicates [ON/OFF] condition of SET indicator.
O/D OFF W/L [ON/OFF]		X	Indicates [ON/OFF] condition of O/D OFF indicator lamp.

 A
B
C
D
E
F
G
H
I
J
K
L
M

DI

COMBINATION METERS

Display item [Unit]	MAIN SIGNALS	SELECTION FROM MENU	Contents
e-4WD W/L [ON/OFF]		X	This item is not used for this model. "OFF" is always displayed.
EPS W/L [ON/OFF]		X	Indicates [ON/OFF] condition of EPS warning lamp.

NOTE:

Some items are not available due to vehicle specification.

*: The monitor will indicate "OFF" even though the brake warning lamp is on if either of the following conditions exist.

- The parking brake is engaged
- The brake fluid level is low

COMBINATION METERS

EKS0010D

Trouble Diagnosis

HOW TO PERFORM TROUBLE DIAGNOSIS

1. Confirm the symptom or customer complaint.
2. Perform preliminary check. Refer to [DI-17, "PRELIMINARY CHECK"](#) .
3. According to the symptom chart, repair or replace the cause of the malfunction. Refer to [DI-17, "Symptom Chart"](#) .
4. Does the meter operate normally? If so, GO TO 5. If not, GO TO 2.
5. Inspection End.

PRELIMINARY CHECK

1. CHECK SELF-DIAGNOSIS OPERATION OF COMBINATION METER

Perform self-diagnosis of combination meter. Refer to [DI-13, "OPERATION PROCEDURE"](#) .

Does self-diagnosis mode operate?

YES >> GO TO 2.

NO >> Check power supply and ground circuit of combination meter. Refer to [DI-17, "Power Supply and Ground Circuit Inspection"](#) .

2. CHECK COMBINATION METER (CONSULT-II)

Select "METER" on CONSULT-II and perform self-diagnosis of combination meter. Refer to [DI-14, "SELF-DIAGNOSTIC RESULTS"](#) .

Self-diagnostic results content

No malfunction detected>> Refer to [DI-17, "Symptom Chart"](#) .

Malfunction detected>> Refer to [DI-14, "Display Item List"](#) .

Symptom Chart

EKS0010E

Symptom	Possible cause
Improper speedometer and odo/trip meter indication.	Refer to DI-18, "Vehicle Speed Signal Inspection" .
Improper tachometer indication.	Refer to DI-20, "Engine Speed Signal Inspection" .
Improper fuel gauge indication.	Refer to DI-20, "Fuel Level Sensor Signal Inspection" .
Low-fuel warning lamp indication is irregular.	
Improper A/T position indication.	Refer to DI-40, "A/T Indicator Does Not Illuminate" .
Improper CVT position indication.	Refer to DI-45, "CVT Indicator Does Not Illuminate" .

Power Supply and Ground Circuit Inspection

EKS0010F

1. CHECK FUSE

Check for blown combination meter fuses.

Power source	Fuse No.
Battery	13
Ignition switch ON or START	14

OK or NG

OK >> GO TO 2.

NG >> Be sure to eliminate cause of malfunction before installing new fuse. Refer to [PG-4, "POWER SUPPLY ROUTING CIRCUIT"](#) .

COMBINATION METERS

2. CHECK POWER SUPPLY CIRCUIT

Check voltage between combination meter harness connector terminals and ground.

Terminals		(-)	Ignition switch position	
(+) Terminal			OFF	ON
Combination meter connector M24	27	Ground	Battery voltage	Battery voltage
	28		0 V	Battery voltage

OK or NG

- OK >> GO TO 3.
- NG >> Repair harness or connector.

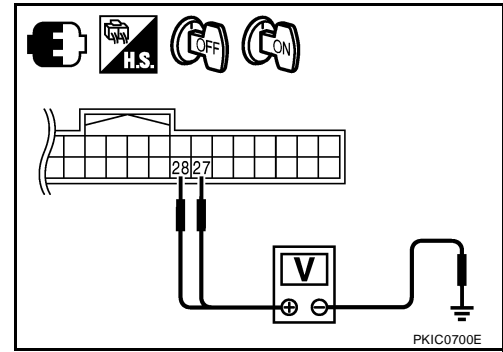

3. CHECK GROUND CIRCUIT

1. Turn ignition switch OFF.
2. Disconnect combination meter connector.
3. Check continuity between combination meter harness connector terminals and ground.

Combination meter connector	Terminal	Ground	Continuity
M24	21		Yes
	22		
	23		

OK or NG

- OK >> Replace combination meter. Refer to [IP-19, "COMBINATION METER"](#) .
- NG >> Repair harness or connector.

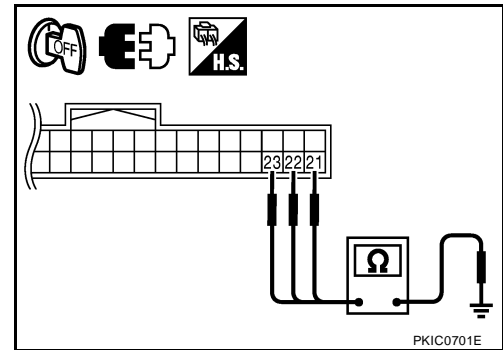

Vehicle Speed Signal Inspection

EKS0010G

Symptom:

- Improper speedometer and odo/trip meter indication.
- Display VEHICLE SPEED CIRC [B2205] at the result of self-diagnosis for combination meter.

WITH ABS

1. CHECK COMBINATION METER INPUT SIGNAL

1. Start engine and select "METER" on CONSULT-II.
2. Using "SPEED METER" on "DATA MONITOR", compare the value of "DATA MONITOR" with speedometer pointer of combination meter.

OK or NG

- OK >> Perform ABS actuator and electric unit (control unit) self-diagnosis. Refer to [BRC-20, "SELF-DIAGNOSIS"](#) .
- NG >> Replace combination meter. Refer to [IP-19, "COMBINATION METER"](#) .

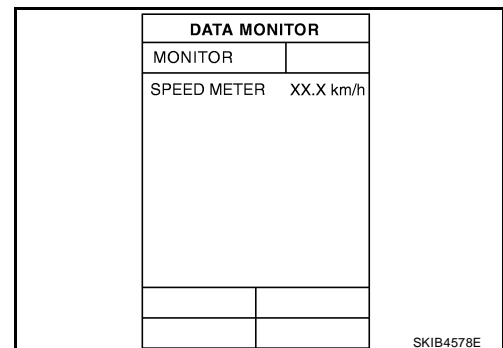

COMBINATION METERS

WITHOUT ABS OR CVT

1. CHECK VEHICLE SPEED SENSOR CIRCUITS

1. Remove vehicle speed sensor.
2. Turn ignition switch ON.
3. Rotate vehicle speed sensor while checking voltage between combination meter harness connector M24 terminals 5 and 26.

Terminals				Voltage (Approx.)
(+)		(-)		
Connector	Terminal	Connector	Terminal	
M24	5	M24	26	0.5

OK or NG

- OK >> Replace combination meter. Refer to [IP-19, "COMBINATION METER"](#) .
 NG >> GO TO 2.

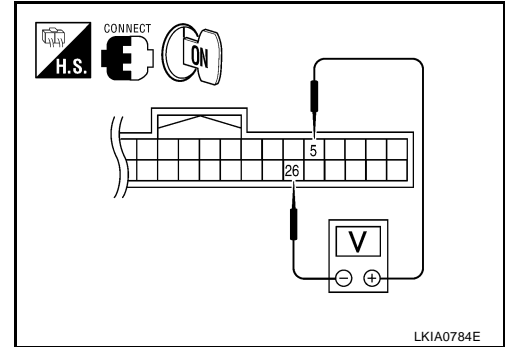

2. CHECK VEHICLE SPEED SENSOR

1. Turn ignition switch OFF.
2. Disconnect vehicle speed sensor connector.
3. Check resistance between vehicle speed sensor terminals 1 and 2.

Terminals				Resistance value (Approx.)
(+)		(-)		
Component	Terminal	Component	Terminal	
Vehicle speed sensor	1	Vehicle speed sensor	2	250Ω

OK or NG

- OK >> Check harness or connector between combination meter and vehicle speed sensor.
 NG >> Replace vehicle speed sensor.

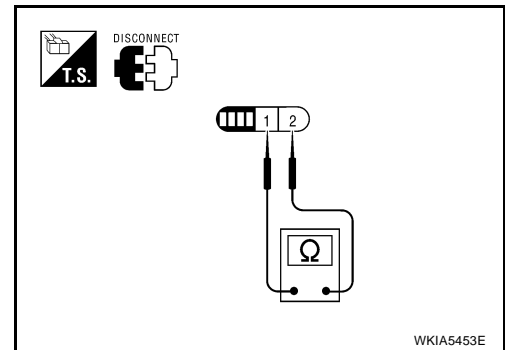

WITH CVT, WITHOUT ABS

1. CHECK COMBINATION METER INPUT SIGNAL

1. Start engine and select "METER" on CONSULT-II.
2. Using "SPEED METER" on "DATA MONITOR", compare the value of "DATA MONITOR" with speedometer pointer of combination meter.

OK or NG

- OK >> Perform TCM self-diagnosis. Refer to [CVT-60, "SELF-DIAGNOSTIC RESULT MODE"](#) .
 NG >> Replace combination meter. Refer to [IP-19, "COMBINATION METER"](#) .

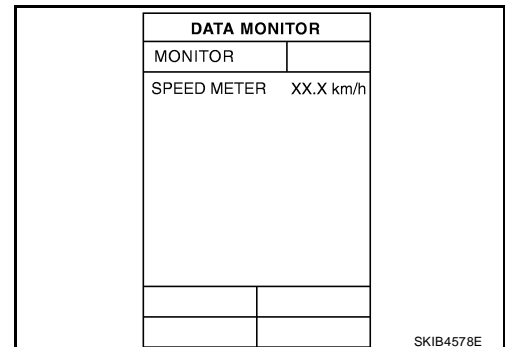

COMBINATION METERS

EKS0010H

Engine Speed Signal Inspection

Symptom: Improper tachometer indication.

1. CHECK COMBINATION METER INPUT SIGNAL

1. Start engine and select "METER" on CONSULT-II.
2. Using "TACHO METER" on "DATA MONITOR", compare the value of "DATA MONITOR" with tachometer pointer of combination meter.

OK or NG

- OK >> Perform ECM self-diagnosis. Refer to [EC-116, "SELF-DIAG RESULTS MODE"](#) .
- NG >> Replace combination meter. Refer to [IP-19, "COMBINATION METER"](#) .

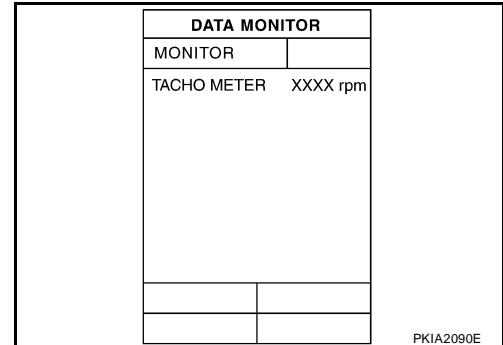

Fuel Level Sensor Signal Inspection

EKS0010J

Symptom:

- Improper fuel gauge indication.
- Low-fuel warning lamp indication is irregular.

NOTE:

The following symptoms do not indicate a malfunction.

- Depending on vehicle position or driving circumstance, the fuel level in the tank shifts and the indication may fluctuate.
- If the vehicle is fueled with the ignition switch ON, the indication will update slowly.
- If the vehicle is tilted when the ignition switch is turned ON, fuel in the tank may flow to one direction resulting in a change of reading.

1. CHECK COMBINATION METER INPUT SIGNAL

1. Select "METER" on CONSULT-II.
2. Using "FUEL METER" on "DATA MONITOR", compare the value of "DATA MONITOR" with fuel gauge pointer of combination meter.

Fuel gauge pointer	Reference value of data monitor [lit.]
Full	Approx. 49
3/4	Approx. 34
1/2	Approx. 22
1/4	Approx. 10
Empty	Approx. 4

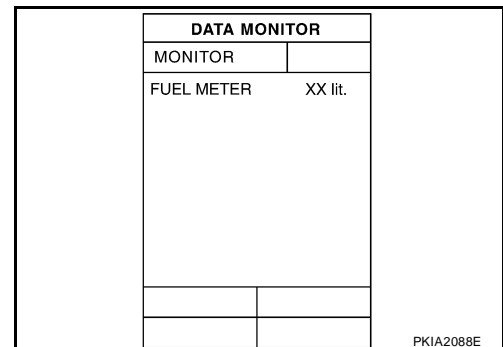

OK or NG

- OK >> GO TO 2.
- NG >> Replace combination meter. Refer to [IP-19, "COMBINATION METER"](#) .

2. CHECK HARNESS CONNECTOR

1. Turn ignition switch OFF.
2. Check combination meter and fuel level sensor unit terminals (meter-side and harness-side) for poor connection.

OK or NG

- OK >> GO TO 3.
- NG >> Repair or replace terminals or connectors.

COMBINATION METERS

3. CHECK FUEL LEVEL SENSOR UNIT CIRCUIT

1. Disconnect combination meter connector and fuel level sensor unit connector.
2. Check continuity between combination meter harness connector (A) and fuel level sensor unit and fuel pump harness connector (B).

A		B		Continuity
Connector	Terminal	Connector	Terminal	
M24	6	B100	2	Yes

3. Check continuity between combination meter harness connector (A) and ground.

A		Ground	Continuity
Connector	Terminal		
M24	6		No

OK or NG

OK >> GO TO 4.

NG >> Repair harness or connector.

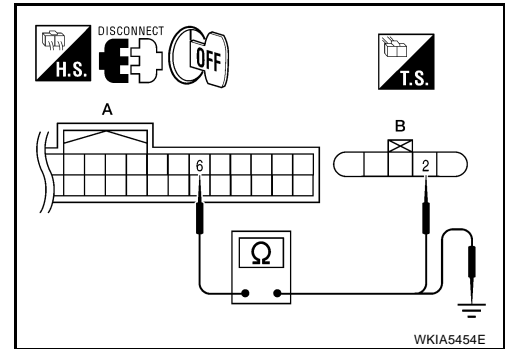

4. CHECK FUEL LEVEL SENSOR UNIT GROUND CIRCUIT

1. Check continuity between combination meter harness connector (A) and fuel level sensor unit and fuel pump harness connector (B).

A		B		Continuity
Connector	Terminal	Connector	Terminal	
M24	24	B100	5	Yes

2. Check continuity between combination meter harness connector (A) and ground.

A		Ground	Continuity
Connector	Terminal		
M24	24		No

OK or NG

OK >> GO TO 5.

NG >> Repair harness or connector.

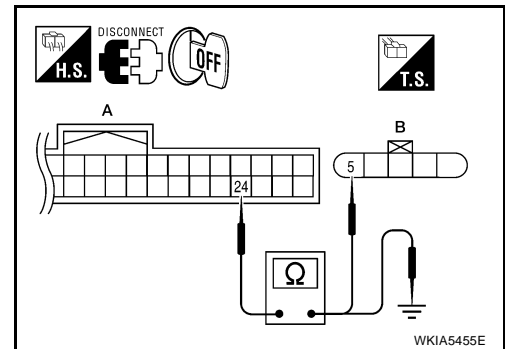

5. CHECK FUEL LEVEL SENSOR UNIT

Check fuel level sensor unit. Refer to [DI-23, "FUEL LEVEL SENSOR UNIT CHECK"](#) .

OK or NG

OK >> Check fuel level sensor unit installation, and check whether the float arm interferes or binds with any of the internal components in the fuel tank. Repair or replace malfunctioning part, if necessary.

NG >> Replace fuel level sensor unit.

COMBINATION METERS

Fuel Gauge Fluctuates, Indicates Wrong Value, or Varies

EKS0010K

1. CHECK FUEL GAUGE FLUCTUATION

Test drive vehicle to see if gauge fluctuates only during driving or at the instant of stopping.

Does the indication value vary only during driving or at the at the instant of stopping?

- YES >> The pointer fluctuation may be caused by fuel level change in the fuel tank. Condition is normal.
NO >> Ask the customer about the situation when the symptom occurs in detail, and perform the trouble diagnosis.

Fuel Gauge Does Not Move to Full position

EKS0010L

1. OBSERVE FUEL GAUGE

Does it take a long time for the pointer to move to FULL position?

YES or NO

- YES >> GO TO 2.
NO >> GO TO 3.

2. IDENTIFY FUELING CONDITION

Was the vehicle fueled with the ignition switch ON?

YES or NO

- YES >> Be sure to fuel the vehicle with the ignition switch OFF. Otherwise, it will take a long time to move to FULL position because of the characteristic of the fuel gauge.
NO >> GO TO 3.

3. OBSERVE VEHICLE POSITION

Is the vehicle parked on an incline?

YES or NO

- YES >> Check the fuel level indication with vehicle on a level surface.
NO >> GO TO 4.

4. OBSERVE FUEL GAUGE POINTER

During driving, does the fuel gauge pointer move gradually toward EMPTY position?

YES or NO

- YES >> Check the components. Refer to [DI-23, "FUEL LEVEL SENSOR UNIT CHECK"](#) .
NO >> The float arm may interfere or bind with any of the components in the fuel tank.

DTC [U1000] CAN Communication Circuit

EKS001AR

Symptom: Display CAN COMM CIRC [U1000] at the result of self-diagnosis for combination meter.

1. CHECK CAN COMMUNICATION

1. Select "SELF-DIAG RESULTS" mode for "METER" with CONSULT-II.
2. Print out CONSULT-II screen.

>> Go to "CAN SYSTEM". Refer to [LAN-44, "TROUBLE DIAGNOSIS"](#) .

COMBINATION METERS

Electrical Components Inspection FUEL LEVEL SENSOR UNIT CHECK

EKS0010M

For removal, refer to [FL-5, "Removal and Installation"](#) .

Check Fuel Level Sensor Unit and Fuel Pump

Check resistance between terminals 2 and 5.

Terminals		Float position mm (in)			Resistance value (Ω) (Approx.)
2	5	1*	Full	160 (8.07)	
		2*	Empty	20 (1.02)	

1* and 2*: When float rod is in contact with stopper.

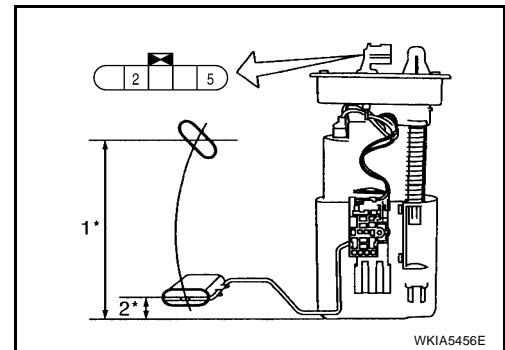

Check Fuel Level Sensor Unit and Fuel Pump Harness

Check continuity at the following terminals.

Terminal	Continuity
2 - Signal terminal (A)	Yes
5 - Ground terminal (B)	

- If the results of check are NG, replace fuel pump assembly. If the results of check are OK, replace fuel level sensor unit.

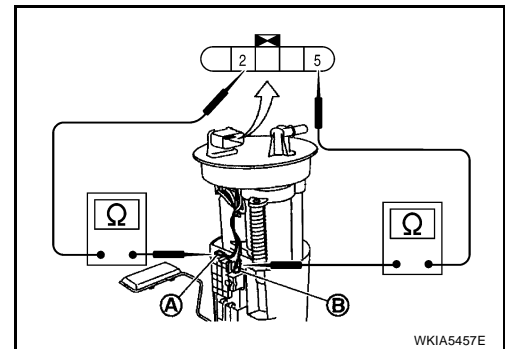

Removal and Installation COMBINATION METER

EKS0010N

Refer to [IP-19, "COMBINATION METER"](#) .

A
B
C
D
E
F
G
H
I
J
L
M

DI

WARNING LAMPS

PFP:24814

EKS0010R

WARNING LAMPS

Schematic

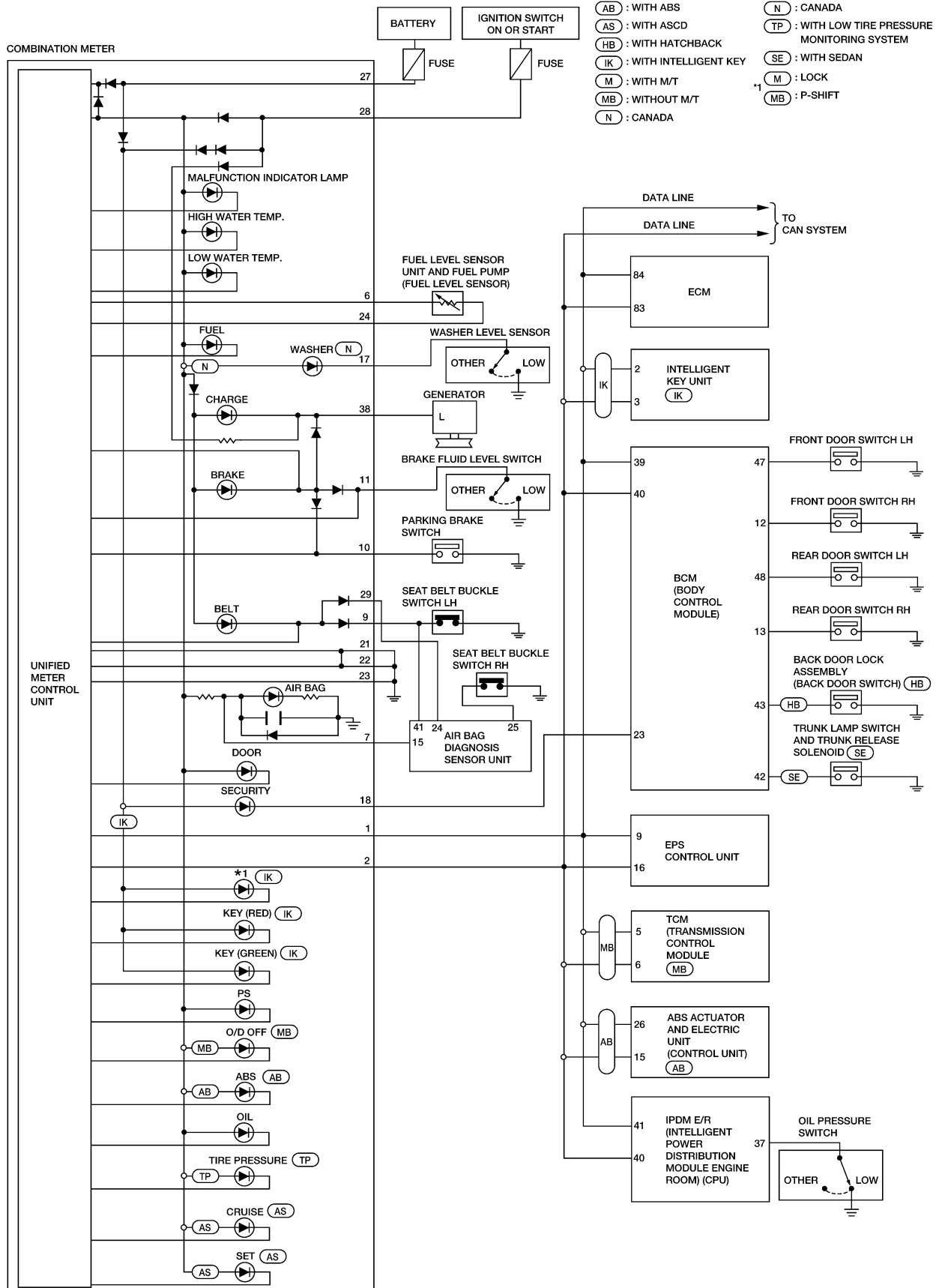

WKWA5819E

WARNING LAMPS

Wiring Diagram — WARN —

EKS0010S

DI-WARN-01

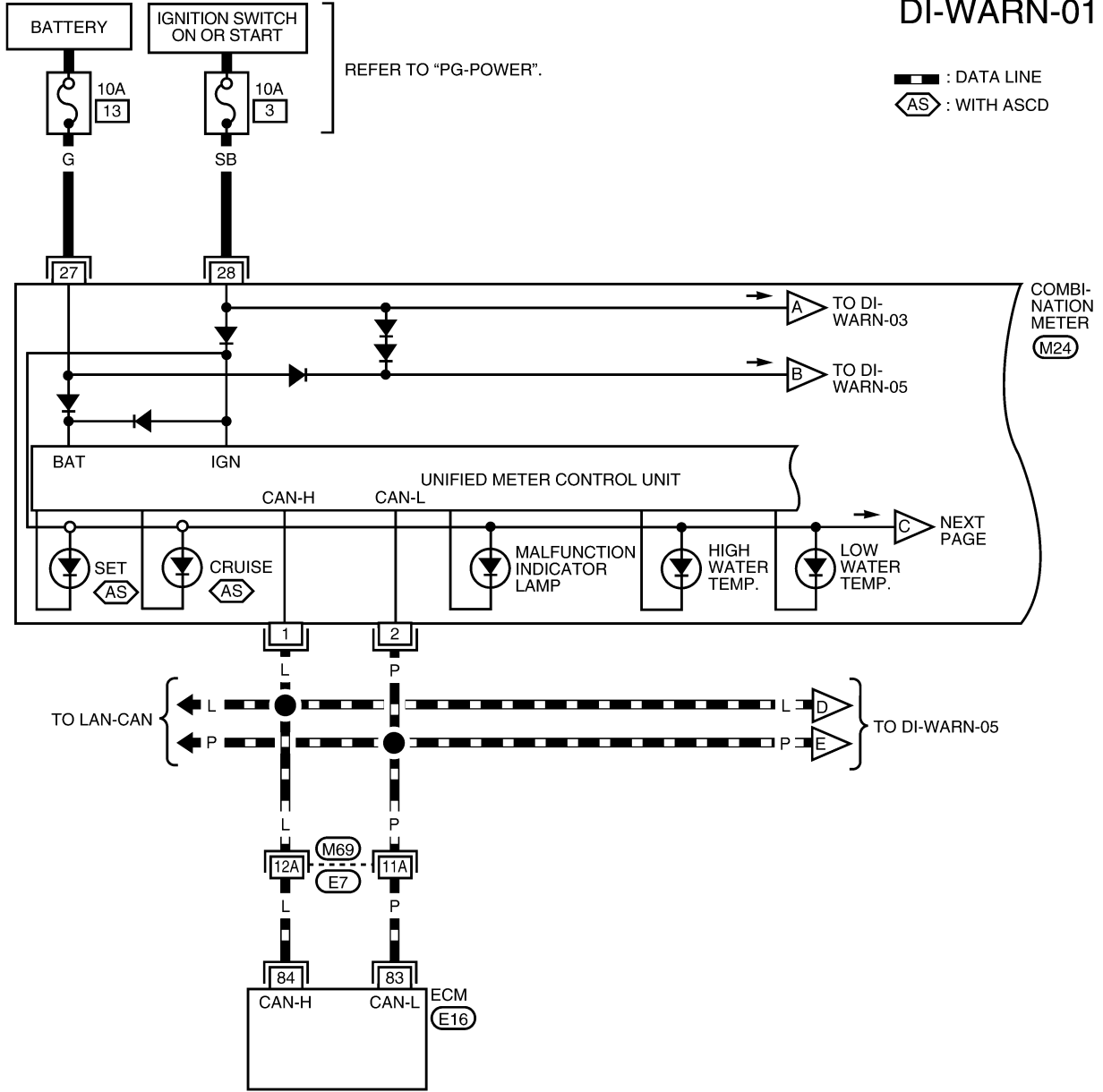

1	2	3	4	5	6	7	8	9	10	11	12	13	14	15	16	17	18	19	20
21	22	23	24	25	26	27	28	29	30	31	32	33	34	35	36	37	38	39	40

(M24) W

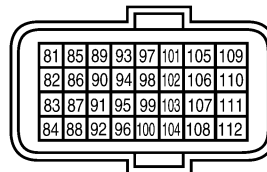

(E16) B



REFER TO THE FOLLOWING.
 (M69) - SUPER MULTIPLE JUNCTION (SMJ)

LKWA0351E

WARNING LAMPS

DI-WARN-02

(N) : CANADA

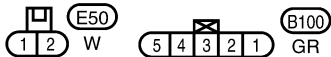
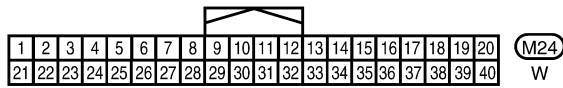
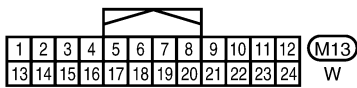
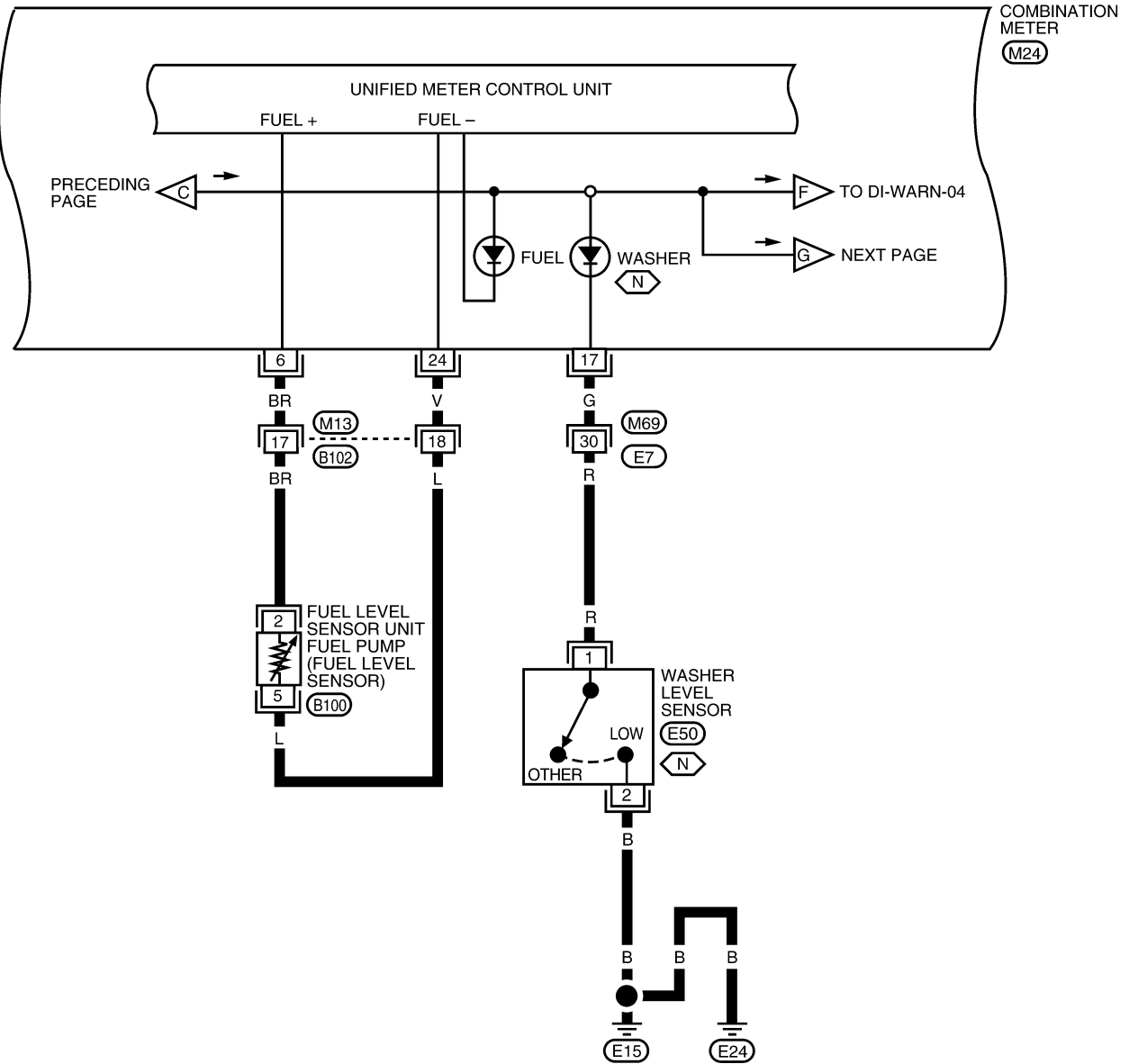

REFER TO THE FOLLOWING.
 (M69) - SUPER MULTIPLE JUNCTION (SMJ)

LKWA0352E

WARNING LAMPS

DI-WARN-03

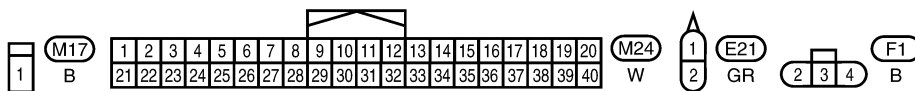
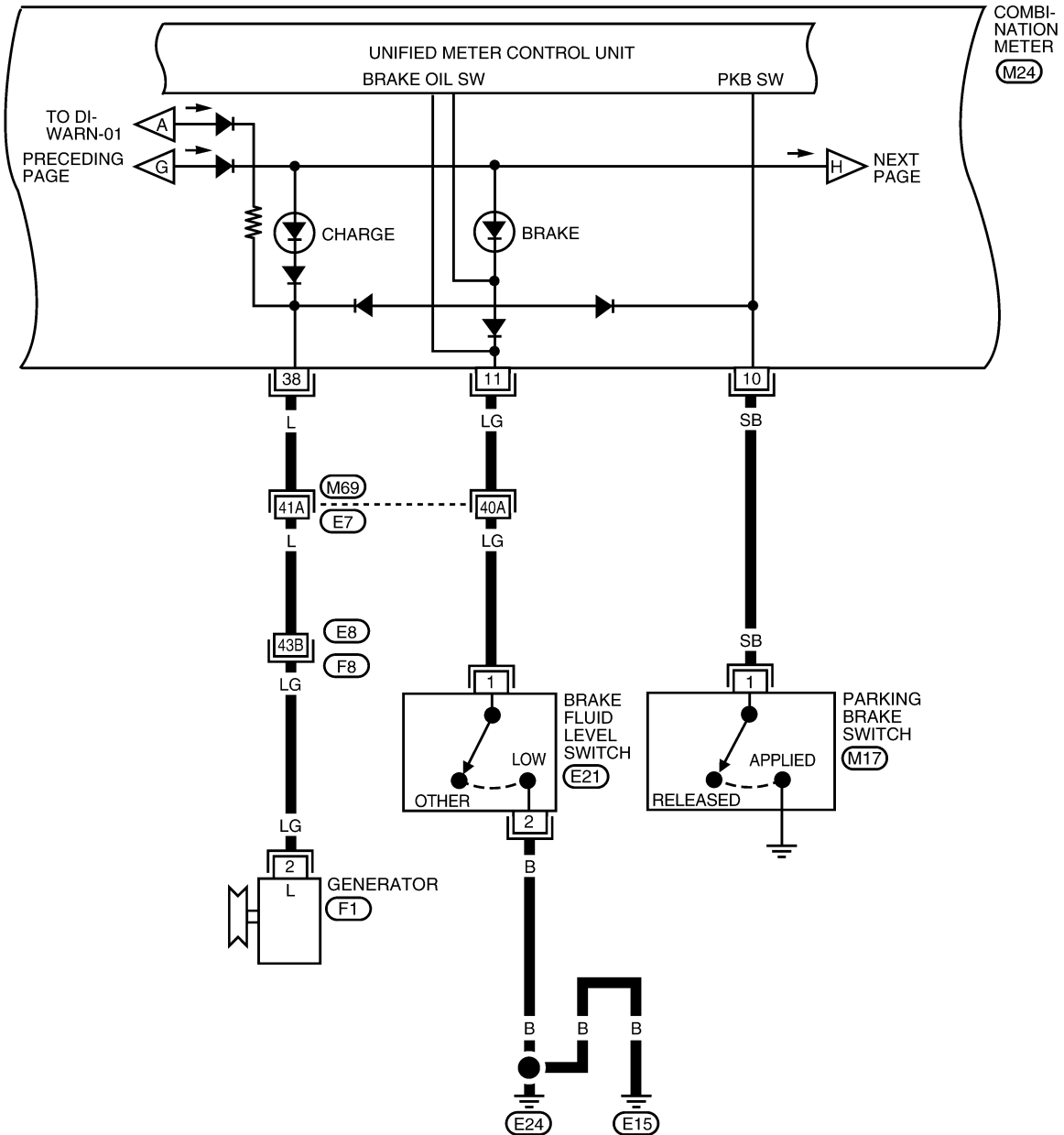

REFER TO THE FOLLOWING.
 (M69), (F8) - SUPER MULTIPLE
 JUNCTION (SMJ)

LKWA0353E

WARNING LAMPS

DI-WARN-04

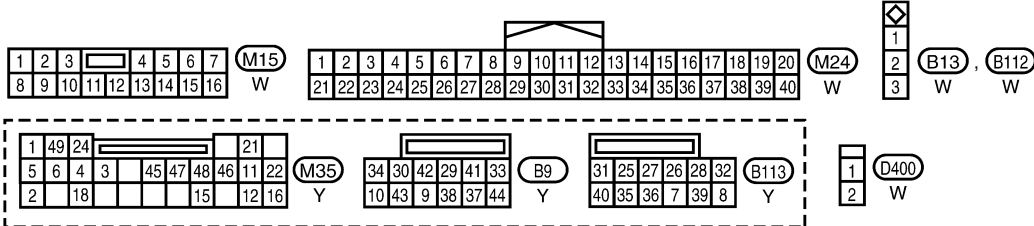
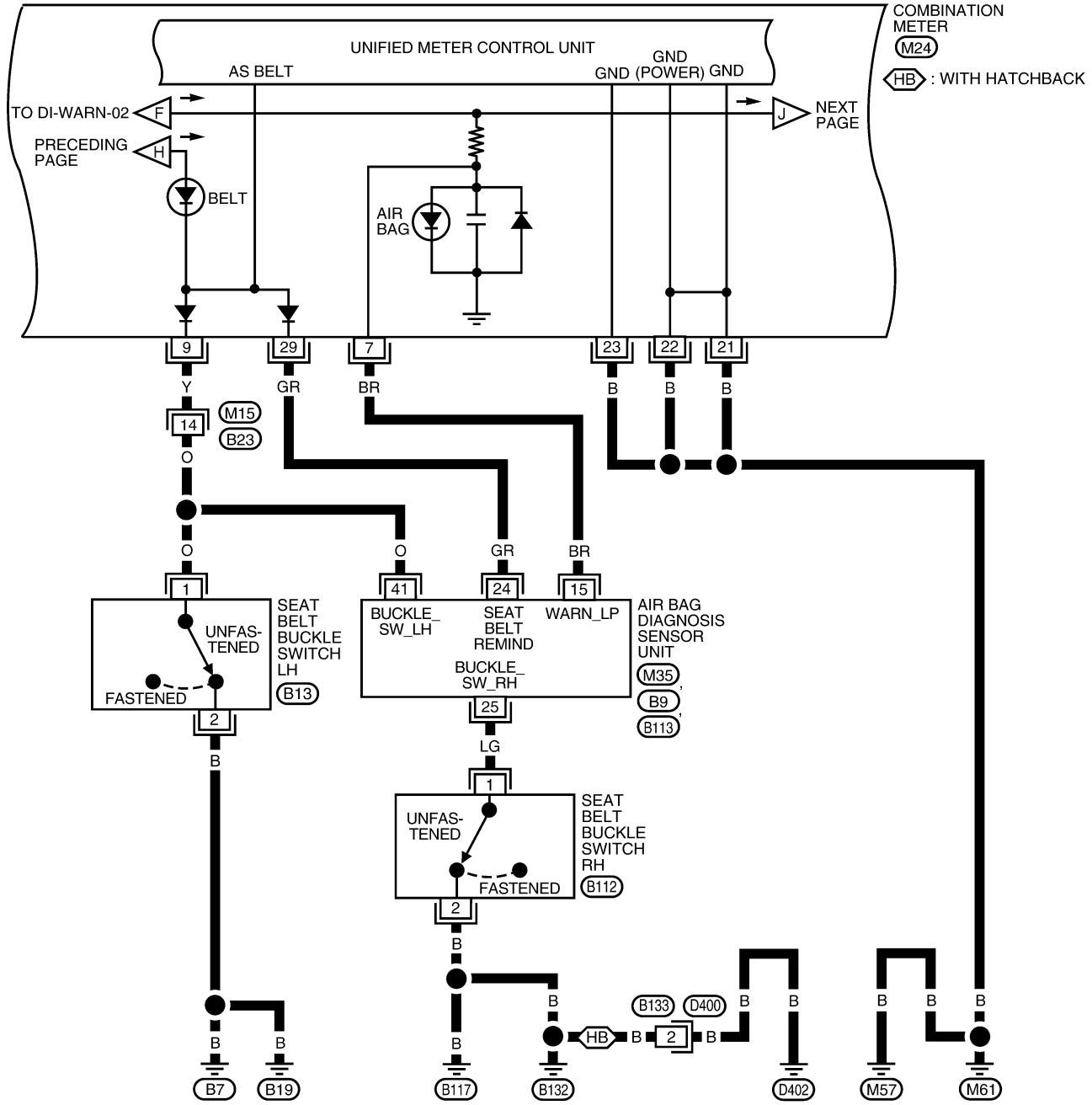

WKWA5804E

WARNING LAMPS

DI-WARN-05

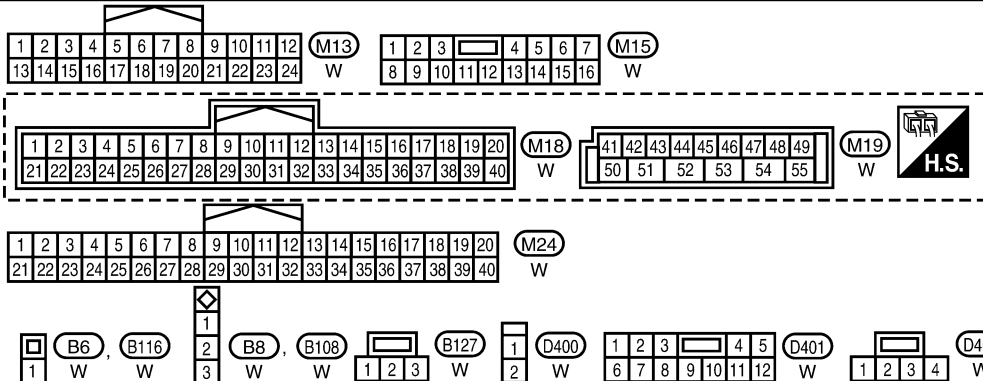
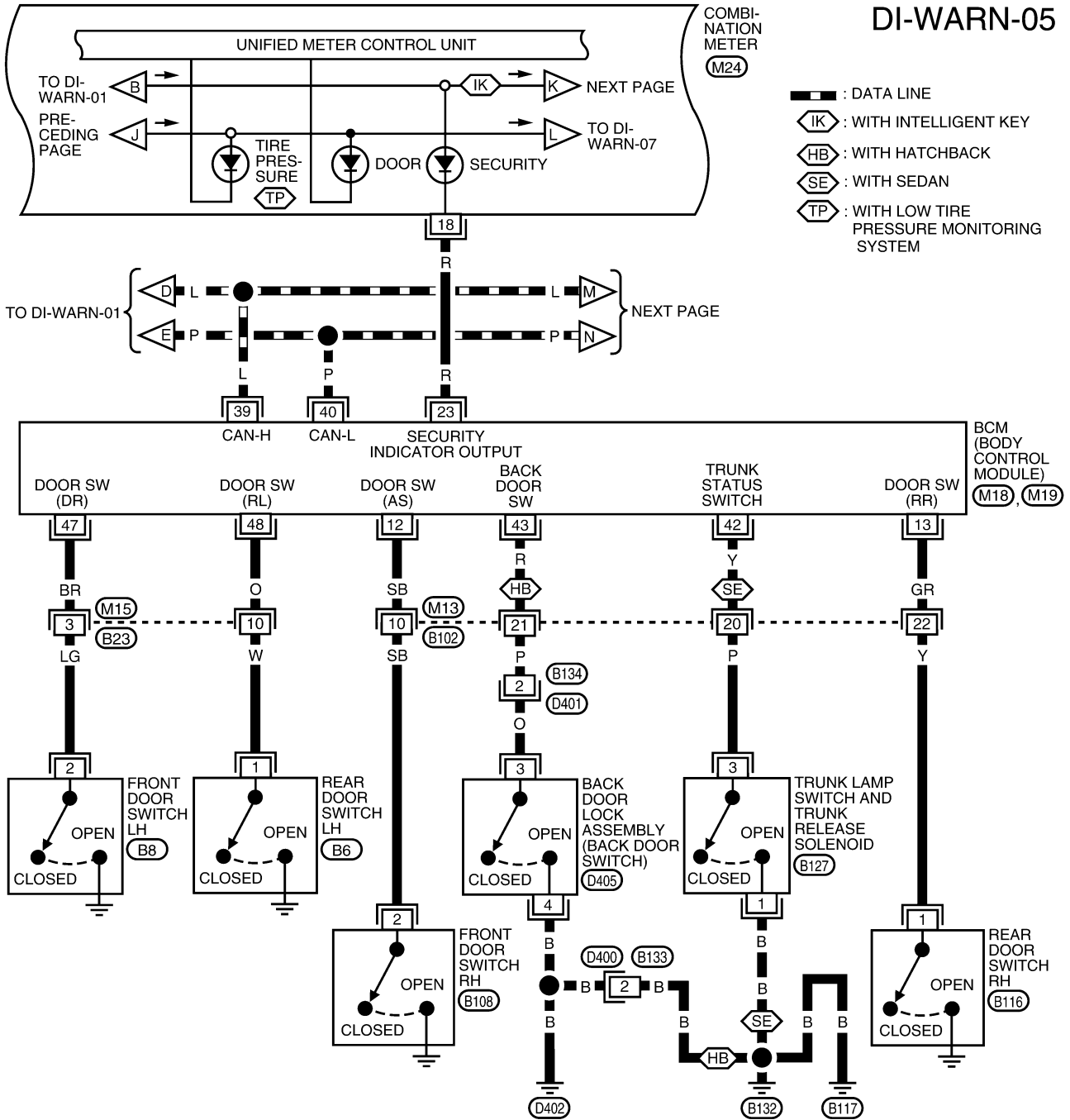

WKWA5805E

WARNING LAMPS

DI-WARN-06

- ▬ : DATA LINE
- ⬡(IK) : WITH INTELLIGENT KEY
- ⬡(M) : WITH M/T
- ⬡(MB) : WITHOUT M/T
- ⬡(M) : LOCK
- *1 ⬡(MB) : P-SHIFT

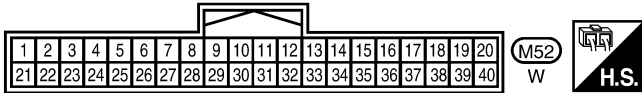
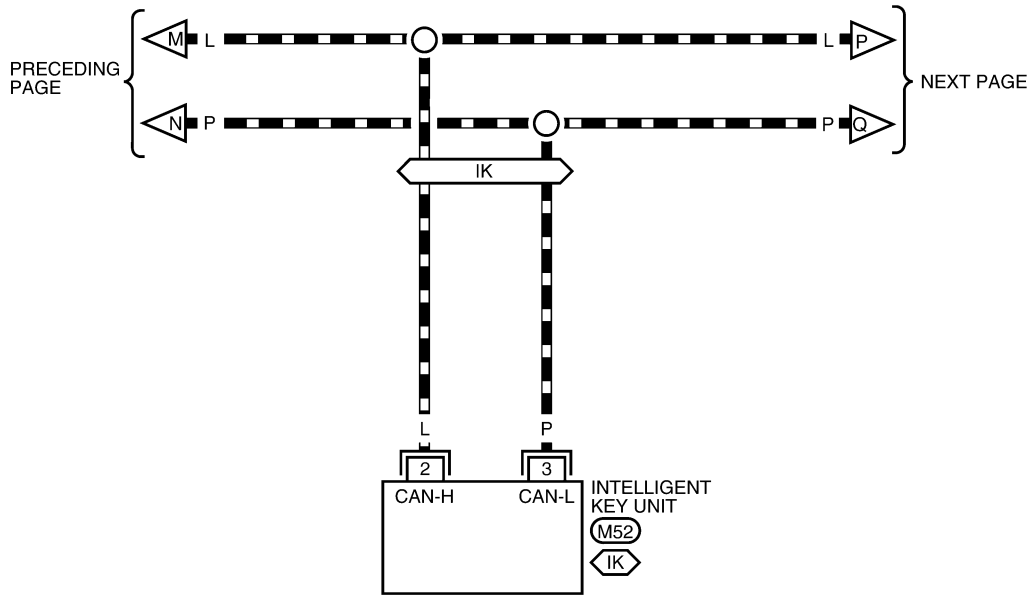
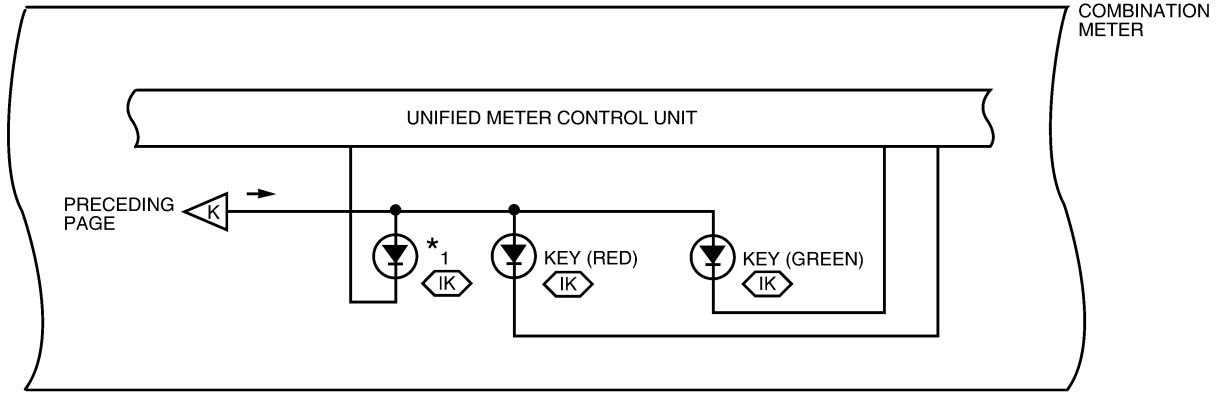

LKWA0356E

WARNING LAMPS

DI-WARN-07

■ : DATA LINE

A
B
C
D
E
F
G
H
I
J
DI
L
M

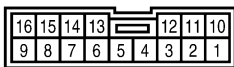
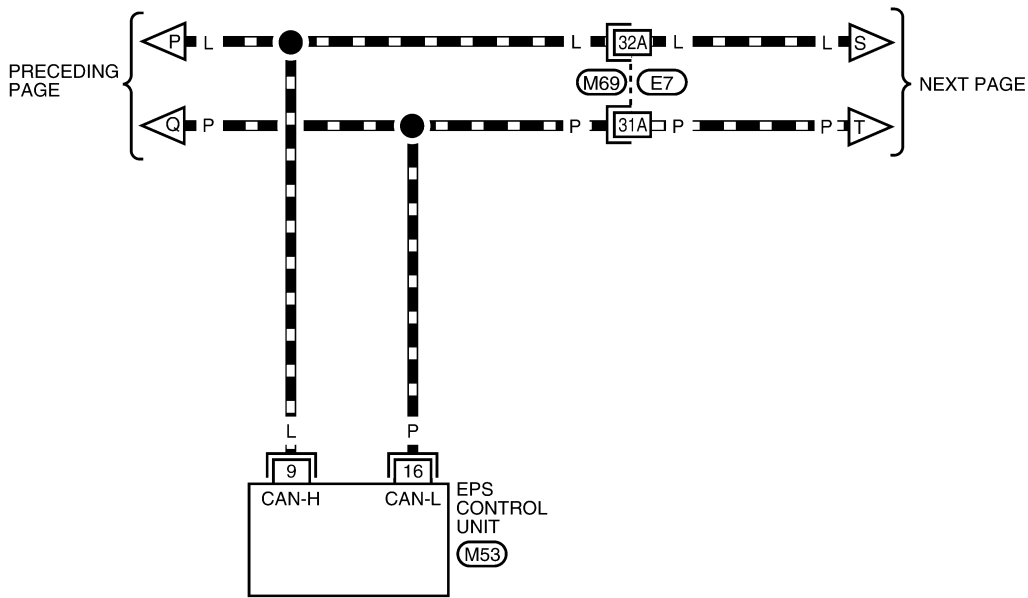
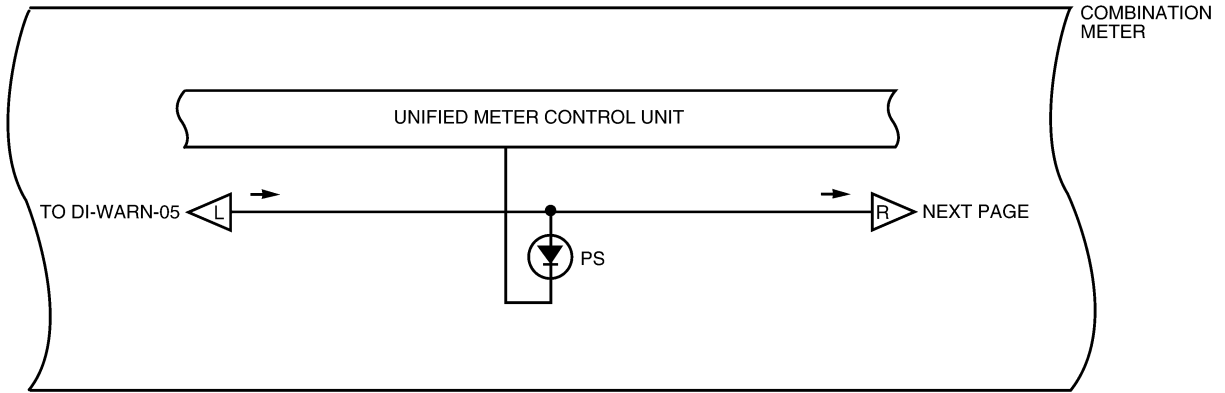

REFER TO THE FOLLOWING.
 (M69) - SUPER MULTIPLE JUNCTION (SMJ)

LKWA0357E

WARNING LAMPS

DI-WARN-08

▬ : DATA LINE

◀MB▶ : WITHOUT M/T

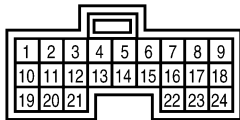
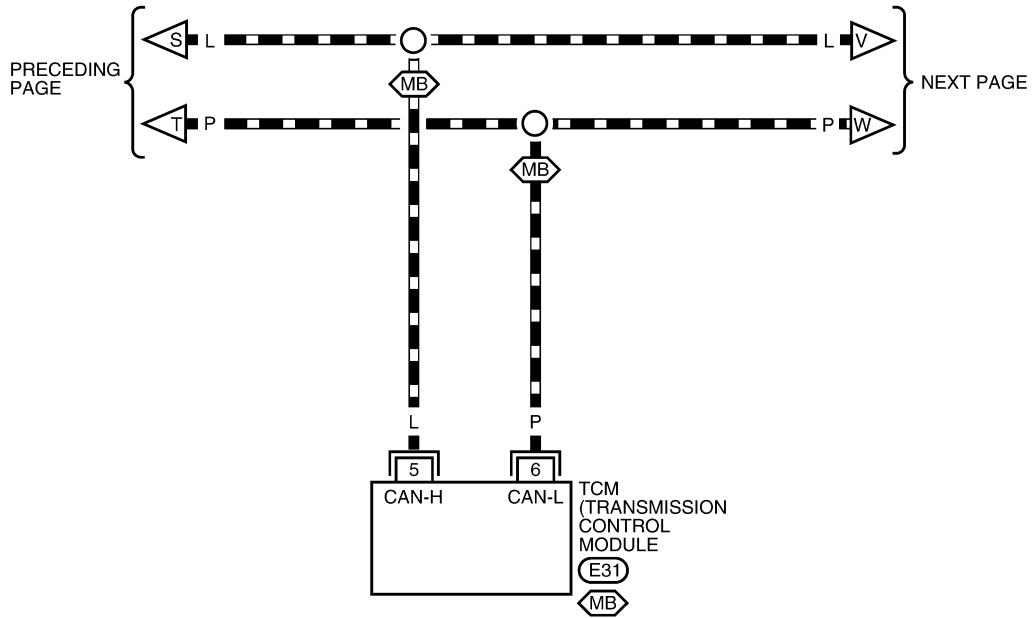
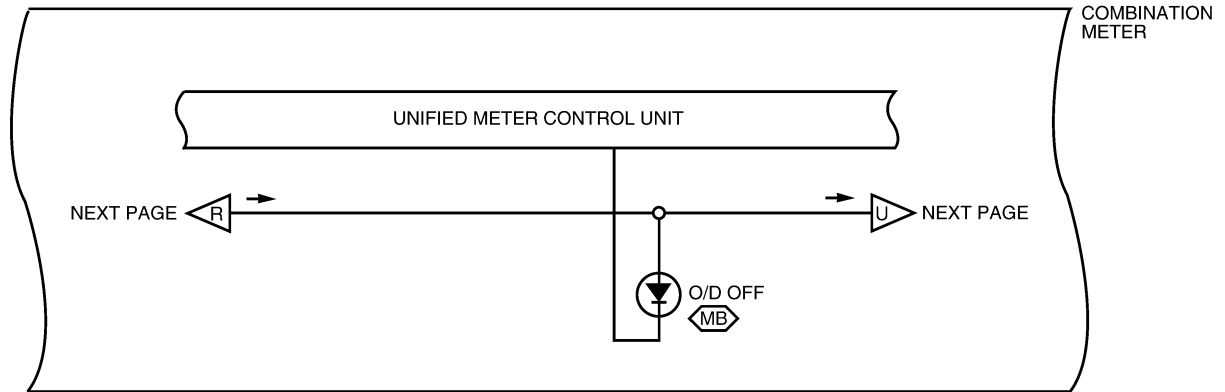

E31
W



LKWA0358E

WARNING LAMPS

DI-WARN-09

▬ : DATA LINE

◊(AB) : WITH ABS

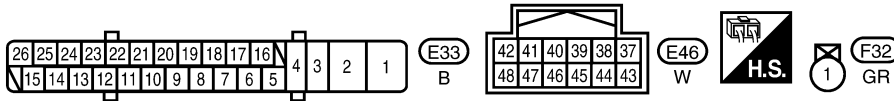
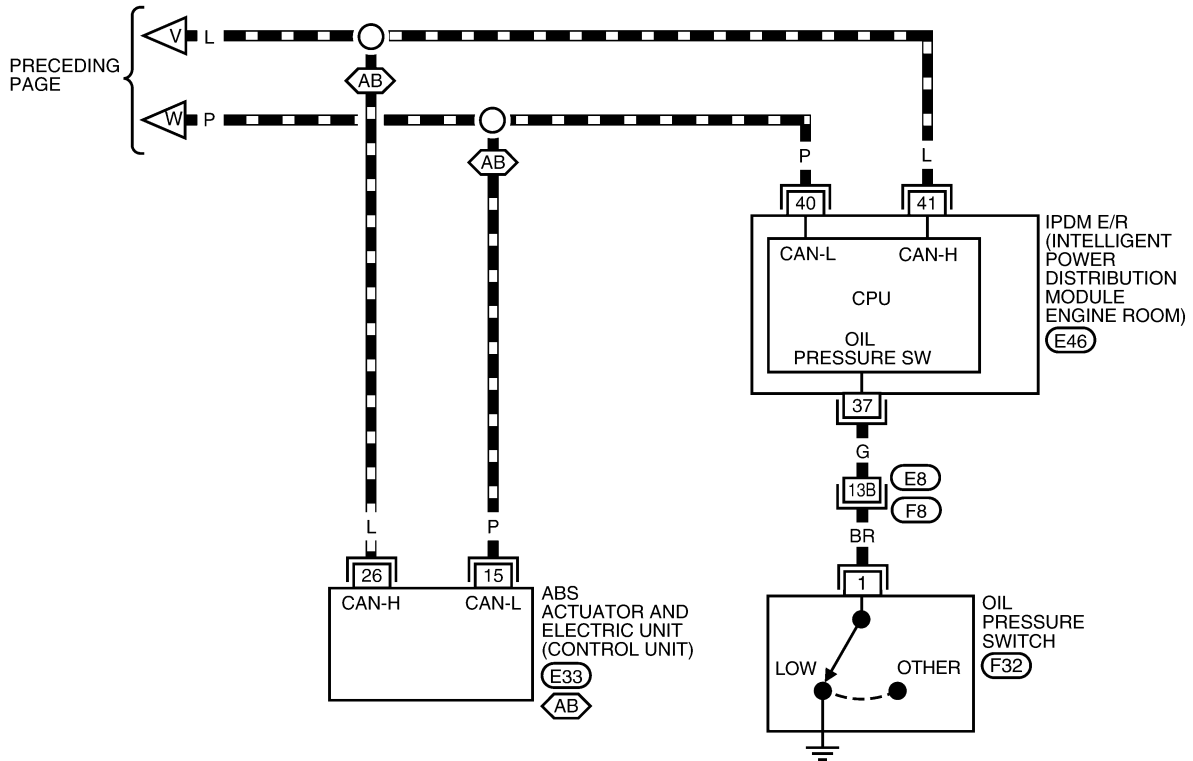
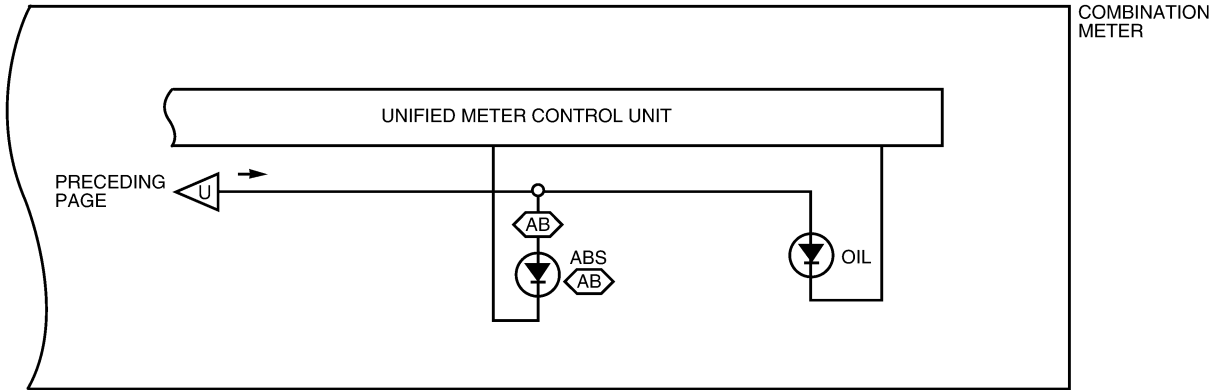

REFER TO THE FOLLOWING.
 (F8) - SUPER MULTIPLE JUNCTION (SMJ)

LKWA0359E

WARNING LAMPS

EKS0010T

Oil Pressure Warning Lamp Stays Off (Ignition Switch ON)

1. CHECK OIL PRESSURE WARNING LAMP OPERATION

Activate IPDM E/R auto active test. Refer to [PG-21, "Auto Active Test"](#) .

Does oil pressure warning lamp blink?

- YES >> GO TO 2.
- NO >> GO TO 5.

2. CHECK IPDM E/R INPUT SIGNAL

1. Turn ignition switch ON.
2. Check voltage between IPDM E/R harness connector and ground.

Terminals		Condition	Voltage (Approx.)
(+)	(-)		
IPDM E/R connector	Terminal		
E46	37	Engine stopped	0 V

OK or NG

- OK >> Replace IPDM E/R. Refer to [PG-30, "Removal and Installation of IPDM E/R"](#) .
- NG >> GO TO 3.

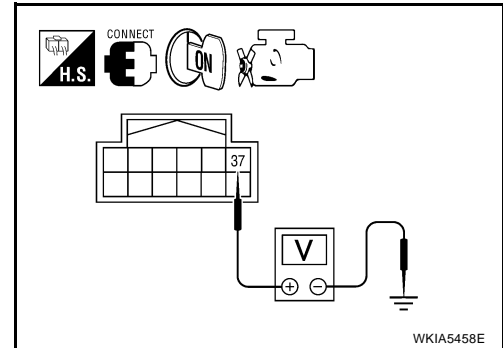

3. CHECK OIL PRESSURE SWITCH

1. Turn ignition switch OFF.
2. Disconnect oil pressure switch connector.
3. Check oil pressure switch. Refer to [DI-36, "OIL PRESSURE SWITCH"](#) .

OK or NG

- OK >> GO TO 4.
- NG >> Replace oil pressure switch.

4. CHECK OIL PRESSURE SWITCH CIRCUIT

1. Disconnect IPDM E/R connector.
2. Check continuity between IPDM E/R harness connector (A) and oil pressure switch harness connector (B).

A		B		Continuity
Connector	Terminal	Connector	Terminal	
E46	37	F32	1	Yes

OK or NG

- OK >> Replace IPDM E/R. Refer to [PG-30, "Removal and Installation of IPDM E/R"](#) .
- NG >> Repair harness or connector.

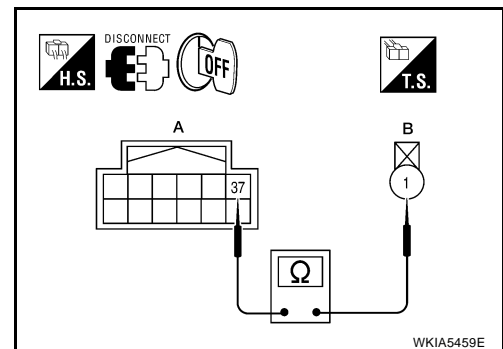

5. CHECK CAN COMMUNICATION

Select "METER" on CONSULT-II, and perform self-diagnosis of combination meter.

Self-diagnostic results content

- No malfunction detected>> GO TO 6.
- Malfunction detected>> Check applicable parts, and repair or replace as necessary.

WARNING LAMPS

6. CHECK COMBINATION METER INPUT SIGNAL

Select "METER" on CONSULT-II. Operate ignition switch with "OIL W/L" of "DATA MONITOR" and check operation status.

"OIL W/L"

When ignition switch is in ON position (Engine stopped.) : ON

When engine running : OFF

OK or NG

OK >> Replace combination meter. Refer to [IP-19, "COMBINATION METER"](#).

NG >> Replace IPDM E/R. Refer to [PG-30, "Removal and Installation of IPDM E/R"](#).

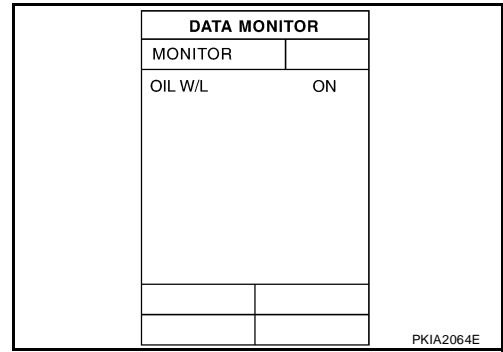

Oil Pressure Warning Lamp Does Not Turn Off (Oil Pressure Is Normal)

EKS0010U

NOTE:

For oil pressure inspection, refer to [LU-5, "OIL PRESSURE CHECK"](#).

1. CHECK OIL PRESSURE WARNING LAMP OPERATION

Activate IPDM E/R auto active test. Refer to [PG-21, "Auto Active Test"](#).

Does oil pressure warning lamp blink?

YES >> GO TO 2.

NO >> GO TO 5.

2. CHECK IPDM E/R OUTPUT SIGNAL

1. Turn ignition switch OFF.
2. Disconnect oil pressure switch connector.
3. Turn ignition switch ON.
4. Check voltage between oil pressure switch harness connector and ground.

Terminals			Voltage (Approx.)
(+)		(-)	
Oil pressure switch connector	Terminal		
F32	1	Ground	12 V

OK or NG

OK >> GO TO 3.

NG >> GO TO 4.

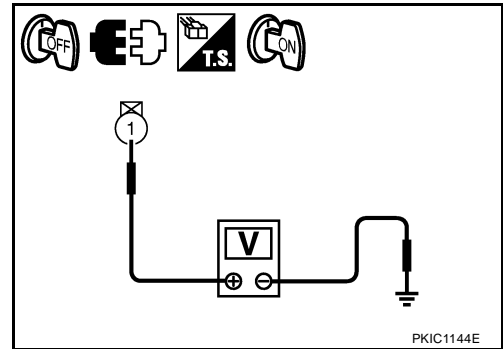

3. CHECK OIL PRESSURE SWITCH

1. Turn ignition switch OFF.
2. Check oil pressure switch. Refer to [DI-36, "OIL PRESSURE SWITCH"](#).

OK or NG

OK >> Replace IPDM E/R. Refer to [PG-30, "Removal and Installation of IPDM E/R"](#).

NG >> Replace oil pressure switch.

WARNING LAMPS

4. CHECK OIL PRESSURE SWITCH CIRCUIT

1. Turn ignition switch OFF.
2. Disconnect IPDM E/R connector.
3. Check continuity between IPDM E/R harness connector and ground.

IPDM E/R connector	Terminal	Ground	Continuity
E46	37		No

OK or NG

- OK >> Replace IPDM E/R. Refer to [PG-30, "Removal and Installation of IPDM E/R"](#) .
- NG >> Repair harness or connector.

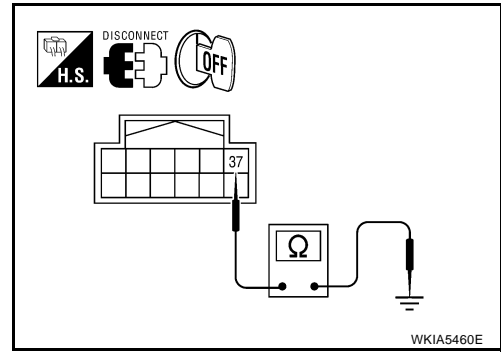

5. CHECK IPDM E/R (CONSULT-II)

Perform self-diagnosis of IPDM E/R. Refer to [PG-19, "SELF-DIAGNOSTIC RESULTS"](#) .

Self-diagnostic results content

- No malfunction detected>>Replace combination meter. Refer to [IP-19, "COMBINATION METER"](#) .
- Malfunction detected>> Check applicable parts, and repair or replace as necessary.

Component Inspection OIL PRESSURE SWITCH

EKS0010V

Check continuity between oil pressure switch and ground.

Condition	Oil pressure [kPa (bar, kg/cm ² , psi)]	Continuity
Engine stopped	Less than 29 (0.3, 0.3, 4)	Yes
Engine running	More than 29 (0.3, 0.3, 4)	No

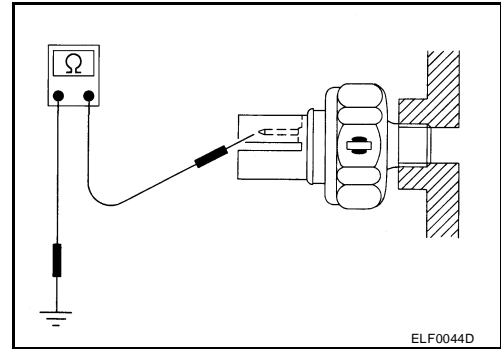

A/T INDICATOR

A/T INDICATOR

PFP:24814

System Description

EKS0010W

The TCM receives A/T indicator signals from the park/neutral position (PNP) switch (R-range, D-range, 2-range and 1-range) and the combination meter (P-range and N-range). The TCM then sends A/T position indicator signals to the combination meter via CAN communication lines. The combination meter indicates the received shift position.

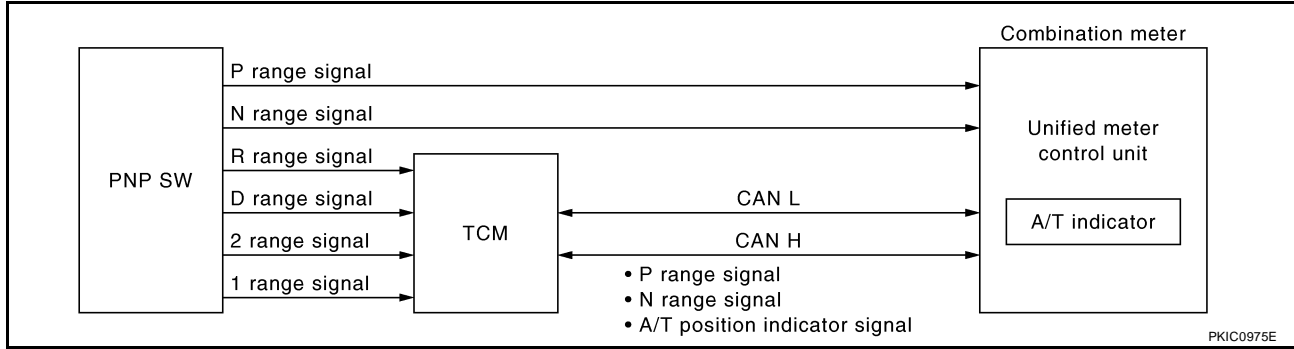

A
B
C
D
E
F
G
H
I
J
L
M

DI

A/T INDICATOR

Wiring Diagram — AT/IND —

EKS0010X

DI-AT/IND-01

▬ : DATA LINE

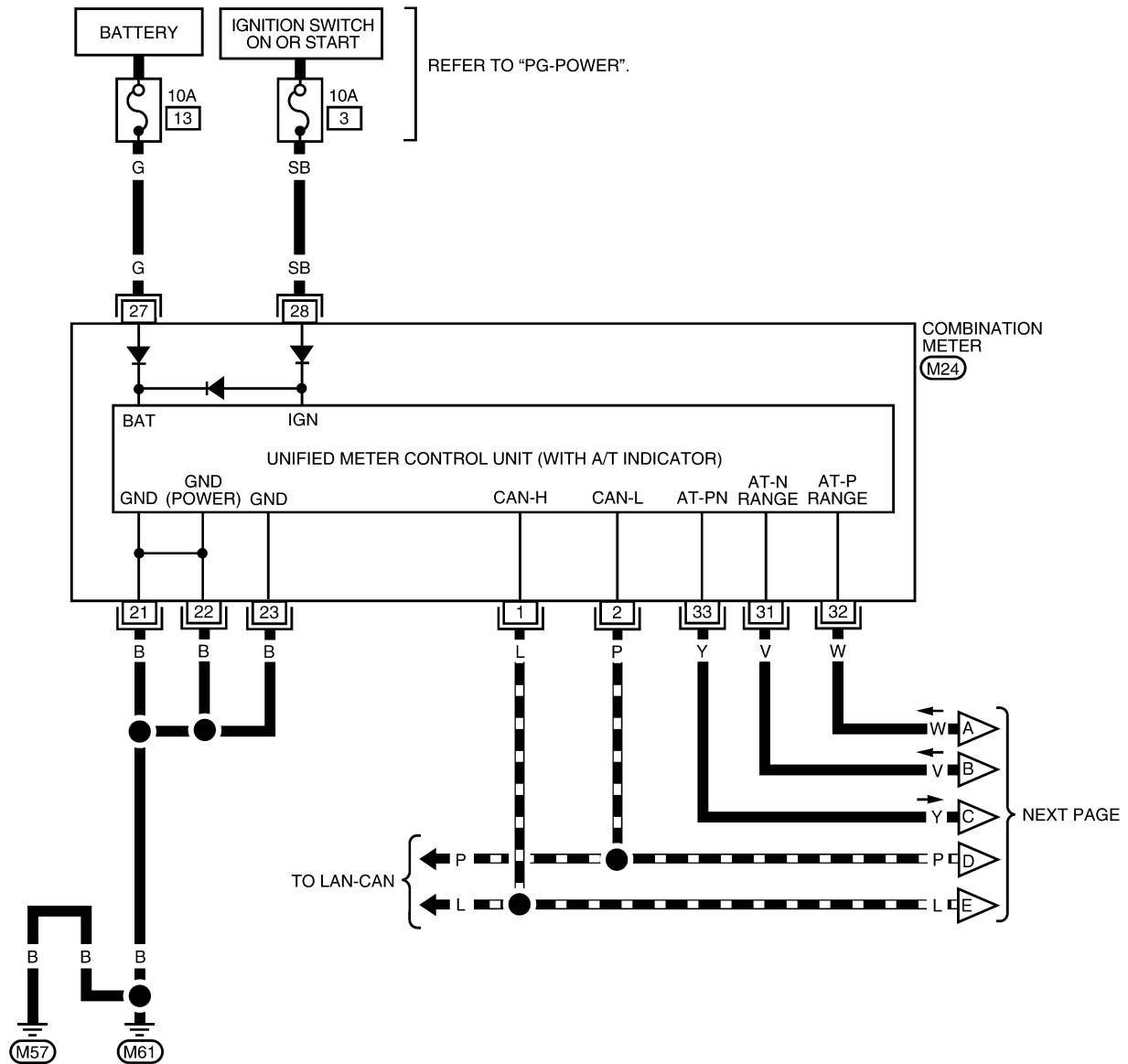

1	2	3	4	5	6	7	8	9	10	11	12	13	14	15	16	17	18	19	20
21	22	23	24	25	26	27	28	29	30	31	32	33	34	35	36	37	38	39	40

(M24)
W

LKWA0360E

A/T INDICATOR

DI-AT/IND-02

▬ : DATA LINE

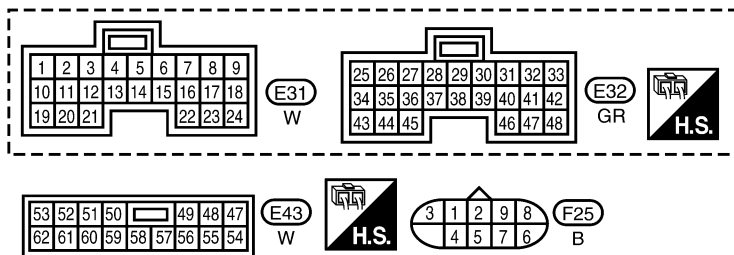
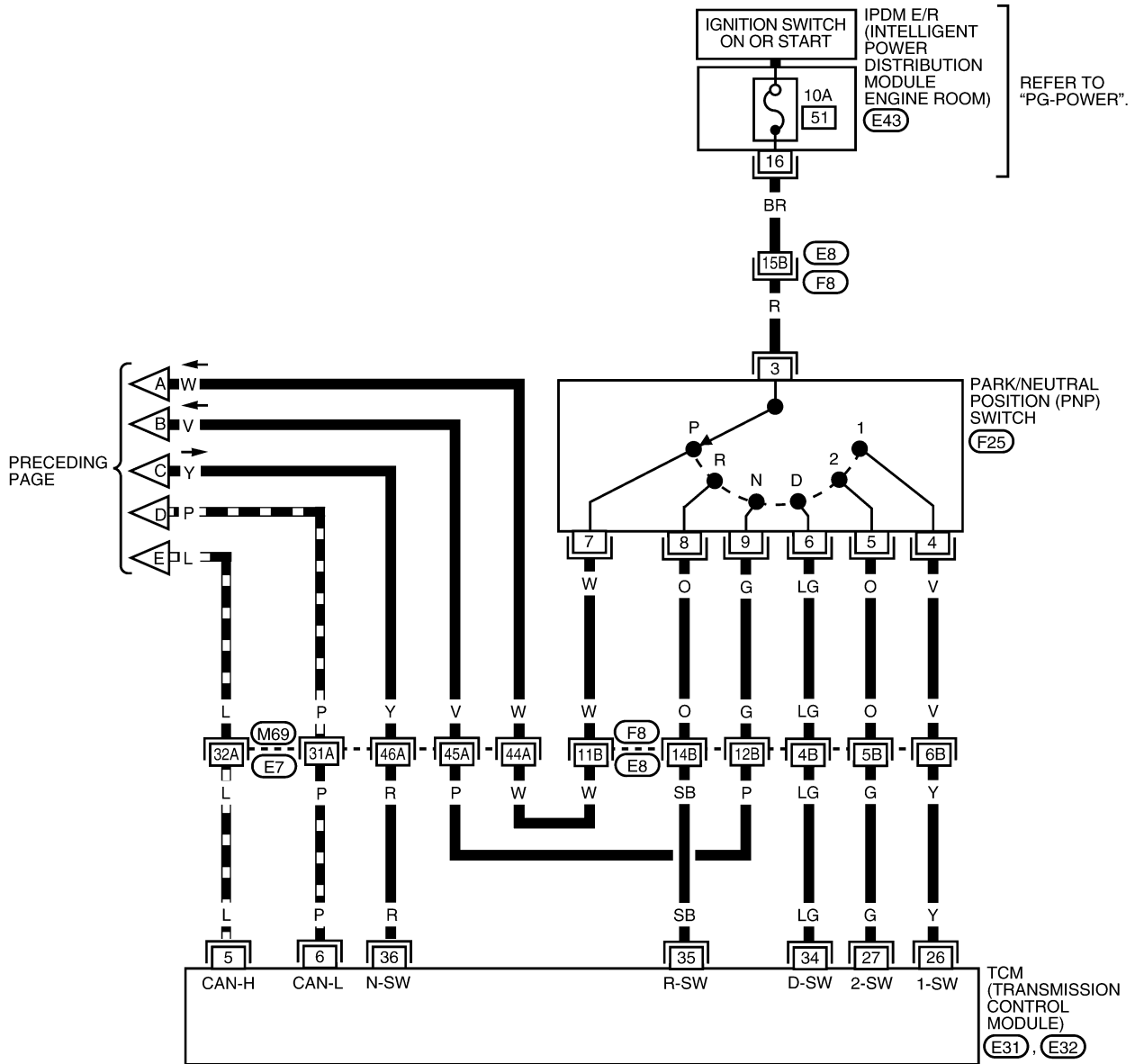

REFER TO THE FOLLOWING.
 (M69), (F8) - SUPER MULTIPLE JUNCTION (SMJ)

LKWA0361E

A/T INDICATOR

EKS0010Y

A/T Indicator Does Not Illuminate

1. CHECK SEGMENT OF A/T INDICATOR

Perform self-diagnosis of combination meter. Refer to [DI-13, "OPERATION PROCEDURE"](#) .

Are all segments displayed?

YES >> GO TO 2.

NO >> Replace combination meter. Refer to [IP-19, "COMBINATION METER"](#) .

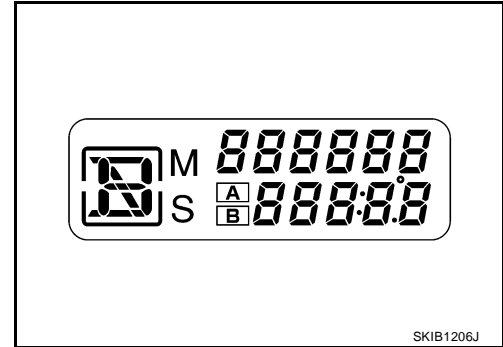

2. CHECK COMBINATION METER (CONSULT-II)

1. Connect CONSULT-II.
2. Select "METER" on CONSULT-II, and perform self-diagnosis of combination meter. Refer to [DI-14, "SELF-DIAGNOSTIC RESULTS"](#) .

Self-diagnostic results content

No malfunction detected>> GO TO 3.

Malfunction detected>> Check applicable parts, and repair or replace as necessary.

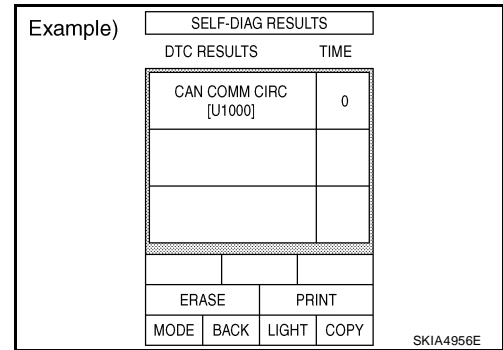

3. CHECK COMBINATION METER INPUT SIGNAL

Use "DATA MONITOR" of "METER" on CONSULT-II. Confirm each indication on the monitor when operating the A/T selector lever.

CONSULT-II display	Switch operation	Operation status
P RANGE IND	P range position	ON
	Except for P range position	OFF
R RANGE IND	R range position	ON
	Except for R range position	OFF
N RANGE IND	N range position	ON
	Except for N range position	OFF
D RANGE IND	D range position	ON
	Except for D range position	OFF
2 RANGE IND	2 range position	ON
	Except for 2 range position	OFF
1 RANGE IND	1 range position	ON
	Except for 1 range position	OFF

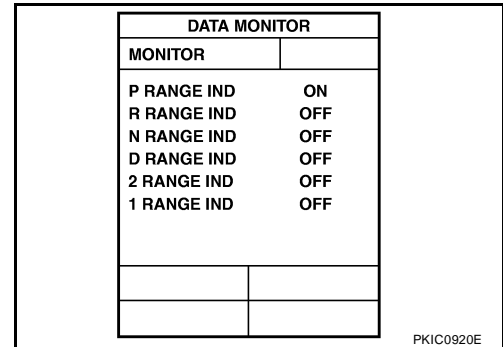

OK or NG

OK >> Replace combination meter. Refer to [IP-19, "COMBINATION METER"](#) .

NG >> GO TO 4.

A/T INDICATOR

4. CHECK SELF-DIAGNOSIS RESULTS OF TCM

Perform self-diagnosis of TCM. Refer to [AT-82, "SELF-DIAGNOSTIC RESULT MODE"](#) .

OK or NG

- OK >> Check TCM input/output signal. Repair or replace malfunctioning part, if necessary. Refer to [AT-31, "Input/Output Signal of TCM"](#) .
- NG >> Check applicable part, and repair or replace as necessary.

A
B
C
D
E
F
G
H
I
J
DI
L
M

DI

CVT INDICATOR

CVT INDICATOR

PF:24820

System Description

EKS001B6

The TCM receives CVT indicator signals from the CVT unit. The TCM then sends CVT position indicator signals to the combination meter via CAN communication lines. The combination meter indicates the received shift position.

CVT INDICATOR

Wiring Diagram — CVTIND —

EKS0018C

DI-CVTIND-01

▬ : DATA LINE

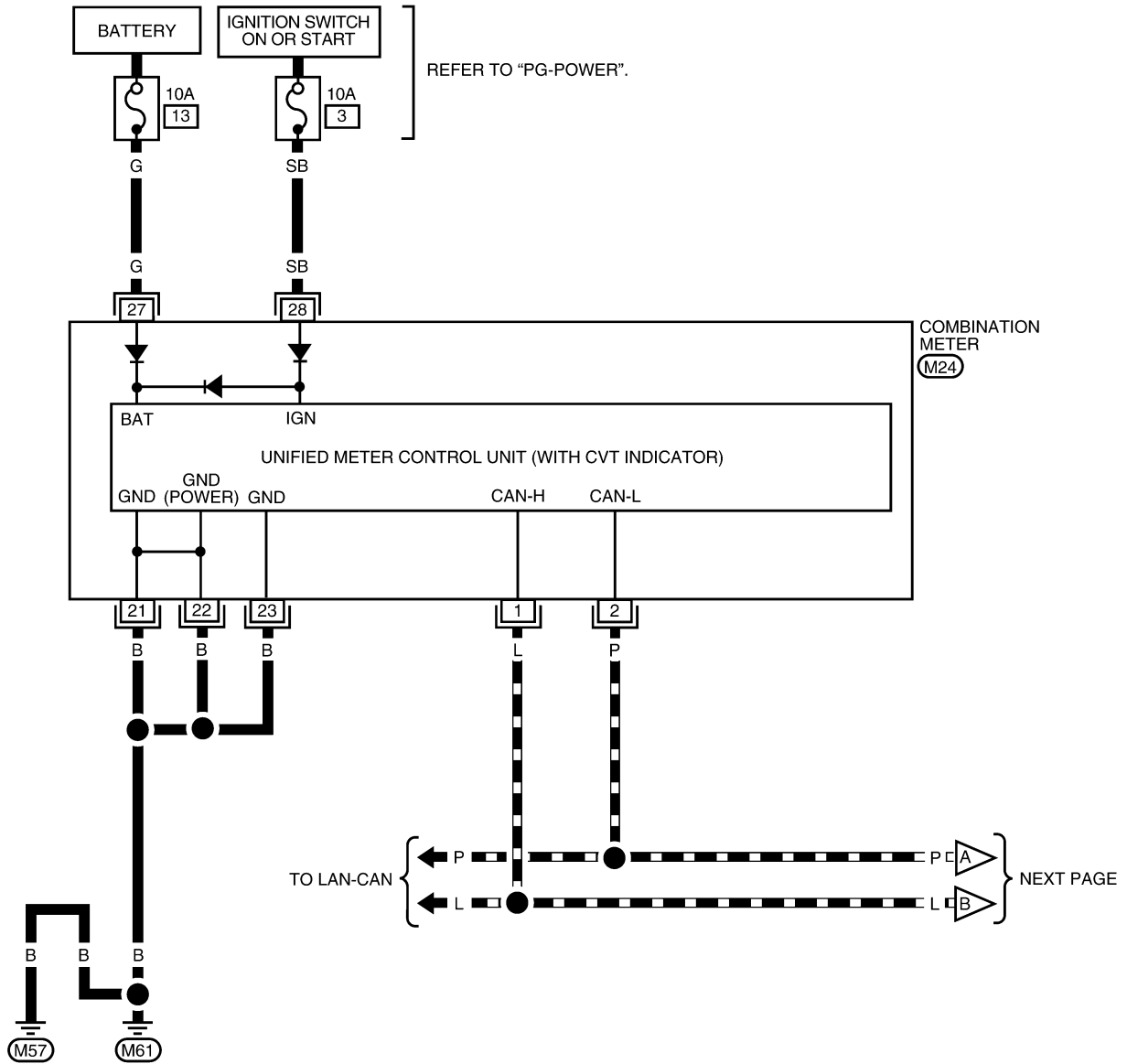

1	2	3	4	5	6	7	8	9	10	11	12	13	14	15	16	17	18	19	20
21	22	23	24	25	26	27	28	29	30	31	32	33	34	35	36	37	38	39	40

(M24)
W

LKWA0362E

CVT INDICATOR

DI-CVTIND-02

— : DATA LINE

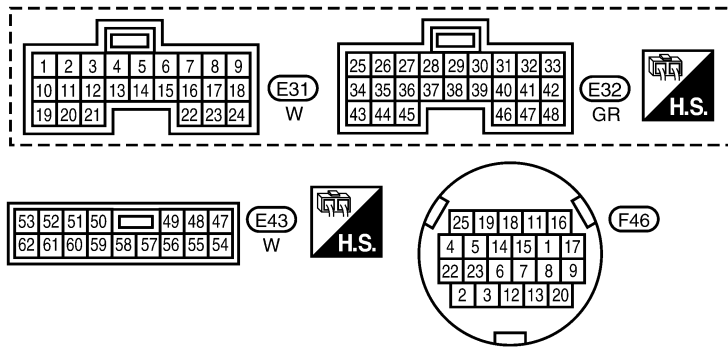
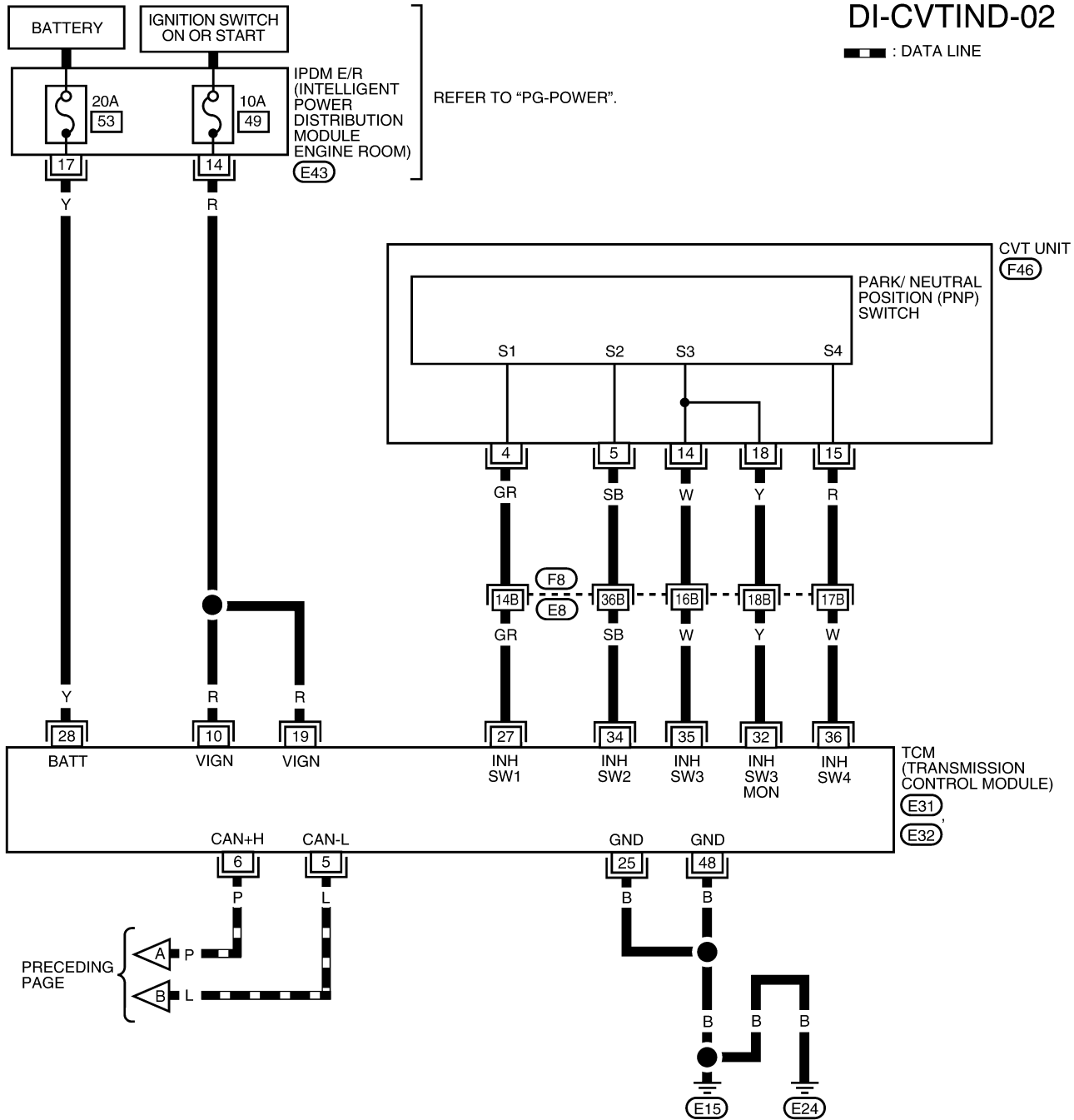

REFER TO THE FOLLOWING.

(F8) - SUPER MULTIPLE JUNCTION (SMJ)

LKWA0363E

CVT INDICATOR

EKS0018E

CVT Indicator Does Not Illuminate

1. CHECK SEGMENT OF CVT INDICATOR

Perform self-diagnosis of combination meter. Refer to [DI-13, "OPERATION PROCEDURE"](#) .

Are all segments displayed?

YES >> GO TO 2.

NO >> Replace combination meter. Refer to [IP-19, "COMBINATION METER"](#) .

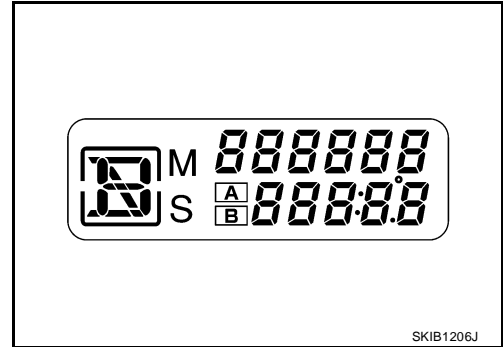

2. CHECK COMBINATION METER (CONSULT-II)

1. Connect CONSULT-II.
2. Select "METER" on CONSULT-II, and perform self-diagnosis of combination meter. Refer to [DI-14, "SELF-DIAGNOSTIC RESULTS"](#) .

Self-diagnostic results content

No malfunction detected>> GO TO 3.

Malfunction detected>> Check applicable parts, and repair or replace as necessary.

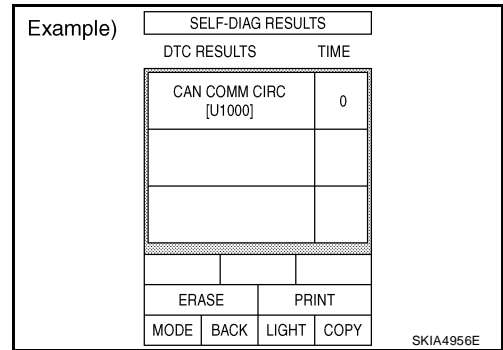

3. CHECK COMBINATION METER INPUT SIGNAL

Use "DATA MONITOR" of "METER" on CONSULT-II. Confirm each indication on the monitor when operating the CVT selector lever.

CONSULT-II display	Switch operation	Operation status
P RANGE IND	P range position	ON
	Except for P range position	OFF
R RANGE IND	R range position	ON
	Except for R range position	OFF
N RANGE IND	N range position	ON
	Except for N range position	OFF
D RANGE IND	D range position	ON
	Except for D range position	OFF
L RANGE IND	L range position	ON
	Except for L range position	OFF

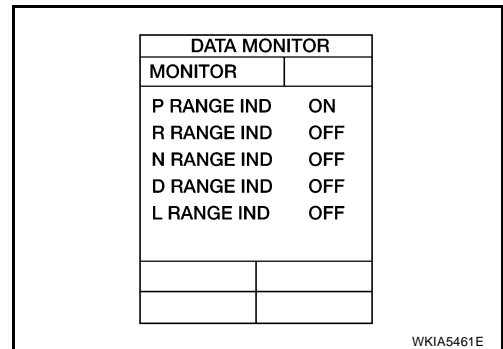

OK or NG

OK >> Replace combination meter. Refer to [IP-19, "COMBINATION METER"](#) .

NG >> GO TO 4.

CVT INDICATOR

4. CHECK SELF-DIAGNOSIS RESULTS OF TCM

Perform self-diagnosis of TCM. Refer to [CVT-60, "SELF-DIAGNOSTIC RESULT MODE"](#) .

OK or NG

- OK >> Check TCM input/output signal. Repair or replace malfunctioning part, if necessary. Refer to [CVT-25, "Input/Output Signal of TCM"](#) .
- NG >> Check applicable part, and repair or replace as necessary.

WARNING CHIME

Component Parts and Harness Connector Location

EKS001B7

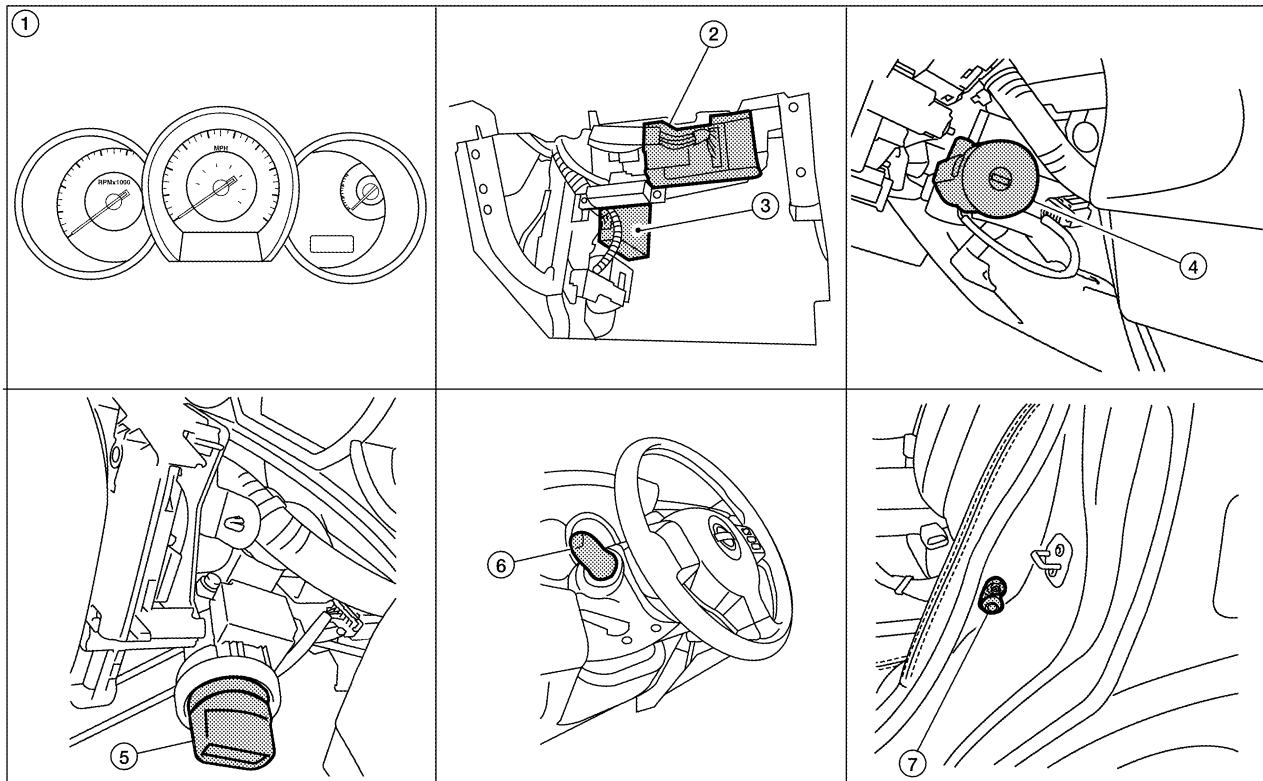

WKIA5462E

- | | | |
|---|---|--|
| 1. Combination meter M24 | 2. BCM M18, M19, M20 (view with glove box removed) | 3. Intelligent Key unit M52 (with Intelligent Key) |
| 4. Key switch and key lock solenoid M27 (without Intelligent Key) | 5. Key switch and ignition knob switch M73 (with Intelligent Key) | 6. Combination switch (lighting switch) M28 |
| 7. Front door switch LH B8 | | |

System Description

EKS001OZ

- Buzzer for warning chime system is installed in the combination meter.
- The buzzer sounds when combination meter receives buzzer output signal with CAN communication line.

POWER SUPPLY AND GROUND CIRCUIT

Power is supplied at all times

- through 40A fusible link (letter g , located in the fuse and fusible link box)
- to BCM terminal 70,
- through 10A fuse [No. 8, located in the fuse block (J/B)]
- to BCM terminal 57,
- through 10A fuse [No. 13, located in the fuse block (J/B)]
- to combination meter terminal 27.

With ignition switch in the ON or START position, power is supplied

- through 10A fuse [No. 6, located in the fuse block (J/B)]
- to BCM terminal 38,
- through 10A fuse [No. 3, located in the fuse block (J/B)]
- to combination meter terminal 28.

Ground is supplied

A
B
C
D
E
F
G
H
I
J
K
L
M



WARNING CHIME

- to BCM terminal 67 and
- to combination meter terminals 21, 22 and 23
- through grounds M57 and M61.

IGNITION KEY WARNING CHIME (WITHOUT INTELLIGENT KEY)

With the key inserted into the key switch, and the ignition switch in the OFF or ACC position, when driver's door is opened, the warning chime will sound.

- BCM detects key inserted into the ignition switch, and sends key warning signal to combination meter with CAN communication line.
- When combination meter receives key warning signal, it sounds warning chime.

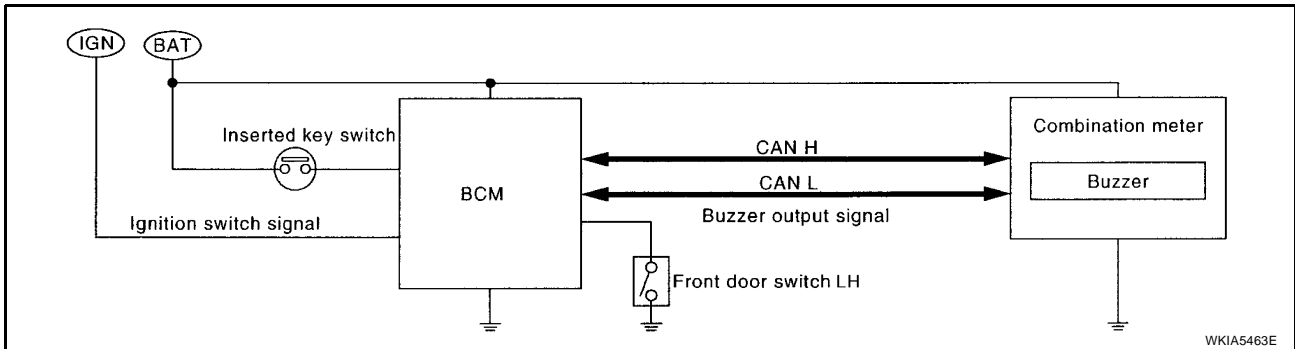

IGNITION KEY WARNING CHIME (WITH INTELLIGENT KEY)

When Mechanical Key Is Used

With the key inserted into the key switch, and the ignition switch in the LOCK or ACC position, when driver's door is opened, the warning chime will sound.

- BCM detects key inserted into the ignition switch, and sends key warning signal to combination meter with CAN communication line.
- When combination meter receives key warning signal, it sounds warning chime.

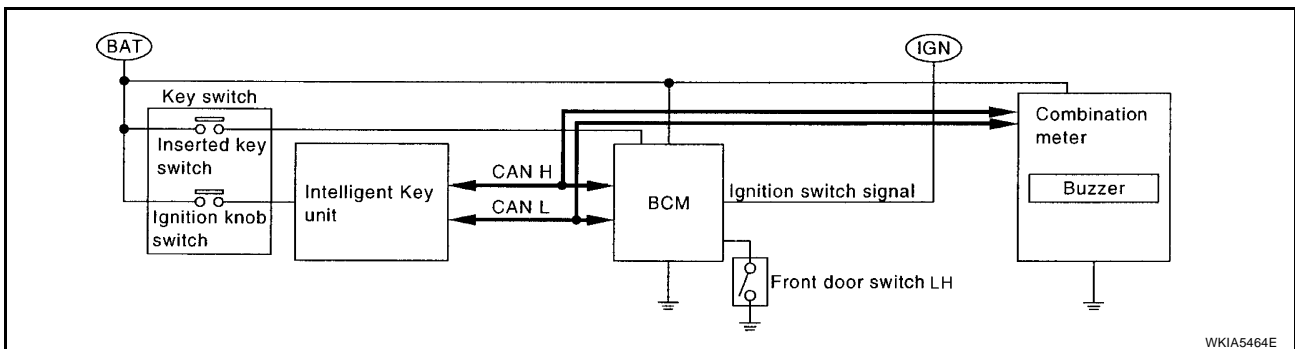

When Intelligent Key Is Carried With The Driver

Refer to [BL-93, "WARNING CHIME/BUZZER/LAMPS FUNCTION"](#) .

LIGHT WARNING CHIME

The warning chime sounds, when driver's door is opened (door switch ON) with lighting switch ON and the ignition switch is in any position other than ON or START.

NOTE:

BCM detected lighting switch in the 1st or 2nd position, refer to [LT-68, "Combination Switch Reading Function"](#)

- BCM detects headlamps are illuminated, and sends light warning signal to combination meter with CAN communication lines.

WARNING CHIME

- When the combination meter receives light warning signal, it sounds warning chime.

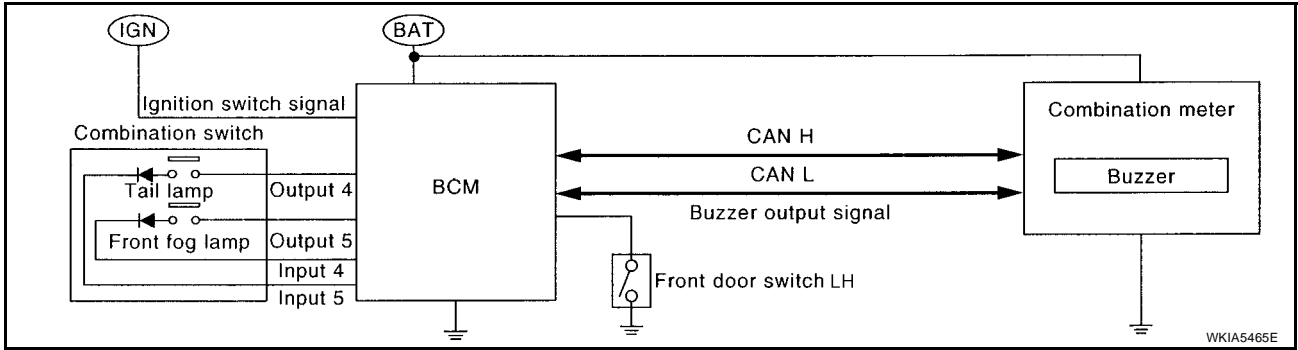

A
B
C
D
E
F
G
H
I
J
DI
L
M

WARNING CHIME

EKS00111

Wiring Diagram — CHIME —

DI-CHIME-01

IK : WITH INTELLIGENT KEY
OK : WITHOUT INTELLIGENT KEY

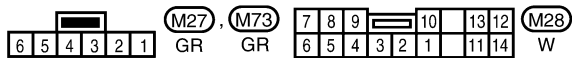
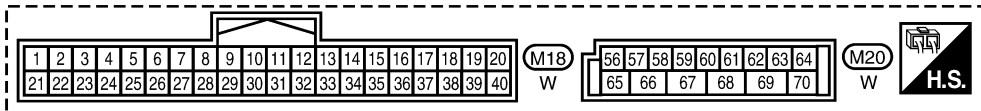
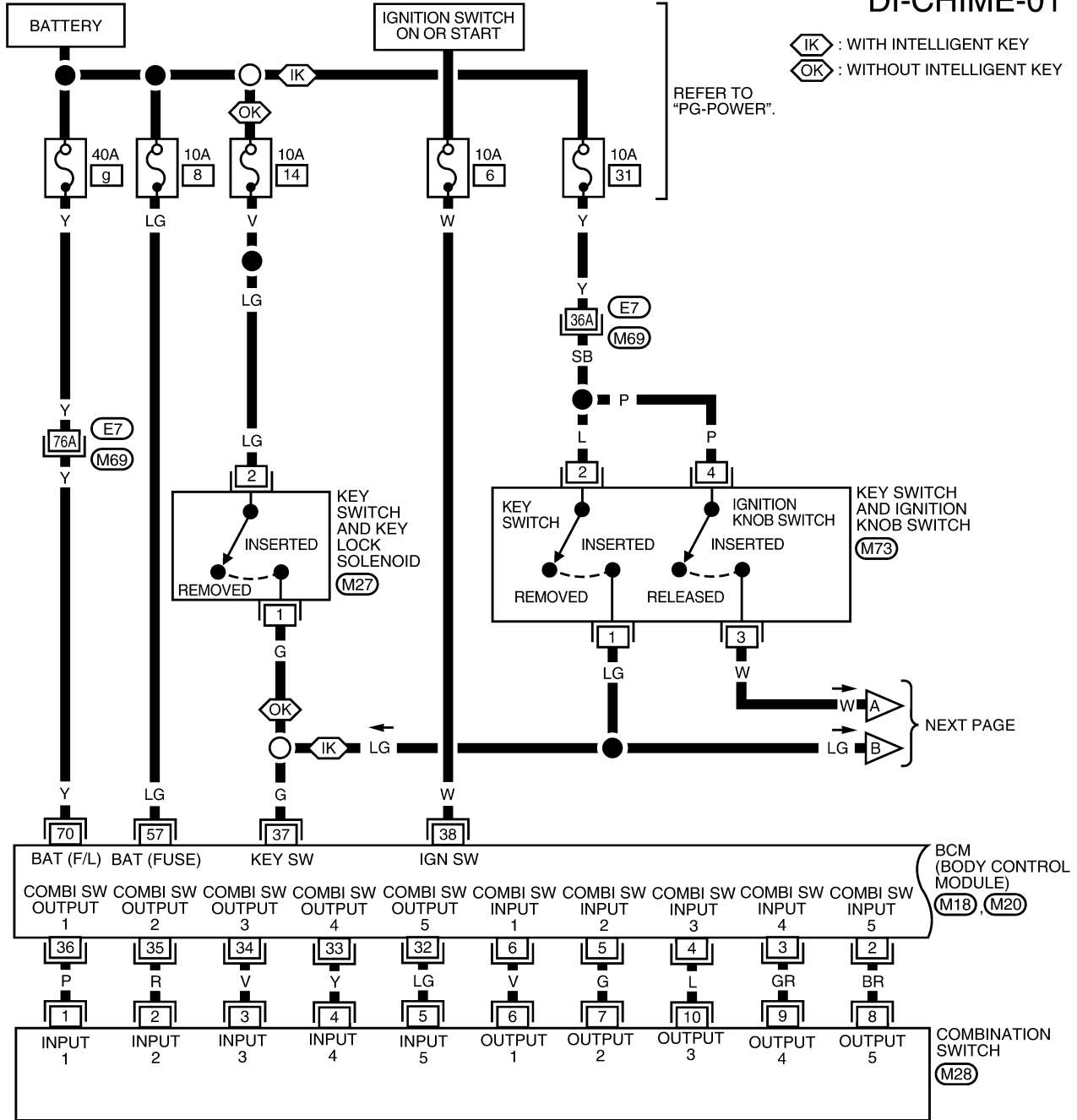

LKWA0364E

WARNING CHIME

DI-CHIME-02

— : DATA LINE

◁ IK ▷ : WITH INTELLIGENT KEY

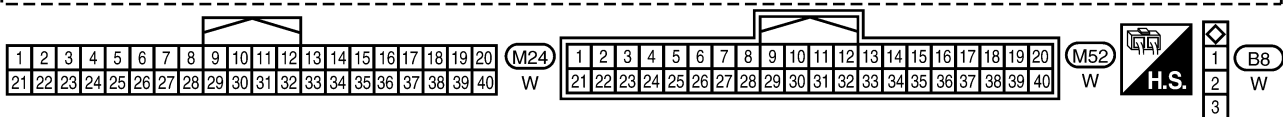
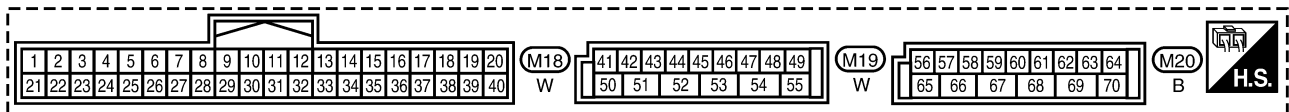
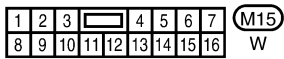
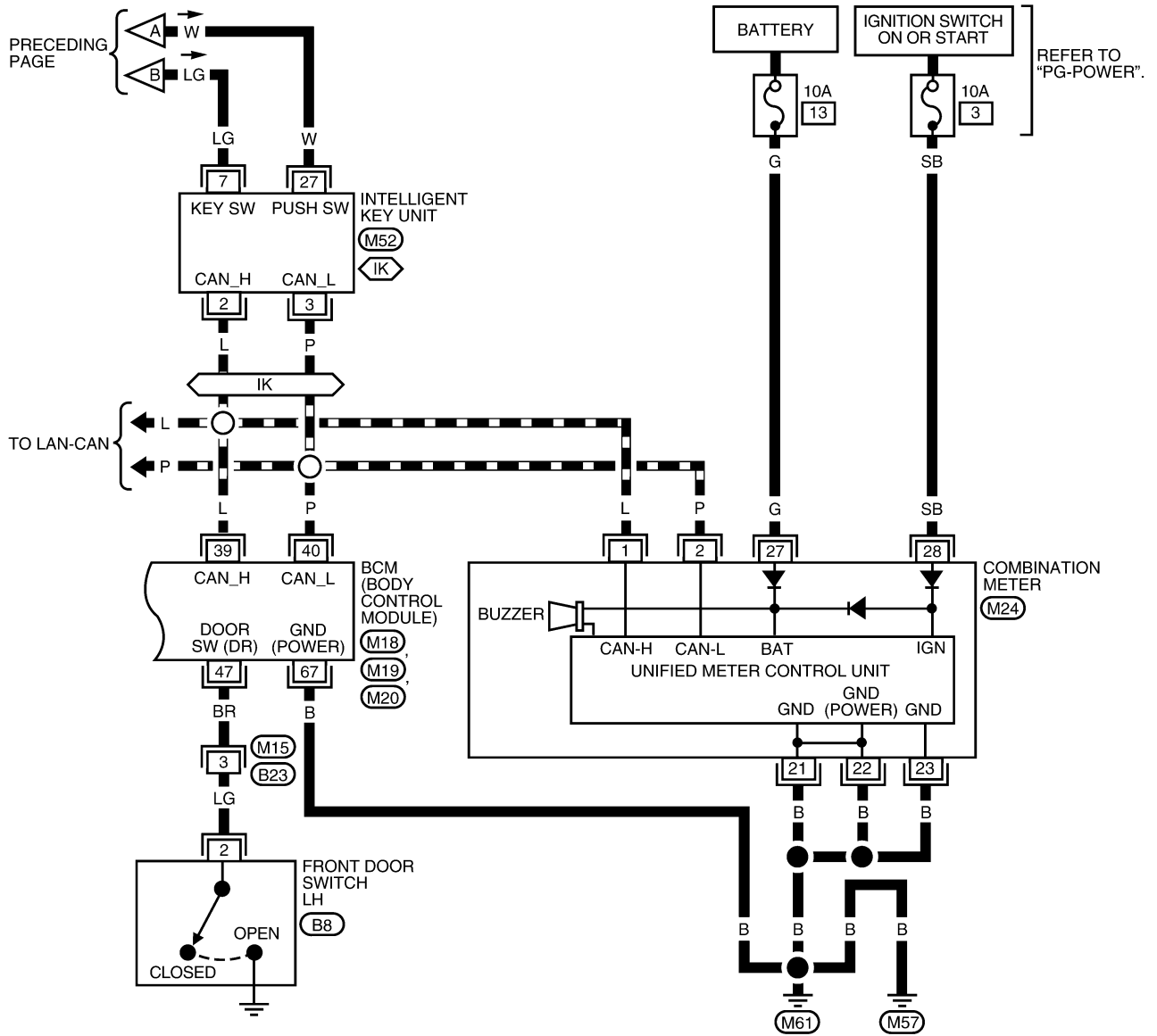

LKWA0365E

WARNING CHIME

Terminals and Reference Values for BCM

EKS00112

Refer to [BCS-13, "Terminals and Reference Values for BCM"](#) .

CONSULT-II Function (BCM)

EKS00113

CONSULT-II can display each diagnostic item using the diagnostic test modes shown following.

BCM diagnostic test item	Diagnostic mode	Description
Inspection by part	WORK SUPPORT	Supports inspections and adjustments. Commands are transmitted to the BCM for setting the status suitable for required operation, input/output signals are received from the BCM and received data is displayed.
	DATA MONITOR	Displays BCM input/output data in real time.
	ACTIVE TEST	Operation of electrical loads can be checked by sending drive signal to them.
	SELF-DIAG RESULTS	Displays BCM self-diagnosis results.
	CAN DIAG SUPPORT MNTR	The result of transmit/receive diagnosis of CAN communication can be read.
	ECU PART NUMBER	BCM part number can be read.
	CONFIGURATION	Performs BCM configuration read/write functions.

CONSULT-II START PROCEDURE

Refer to [GI-38, "CONSULT-II Start Procedure"](#) .

DATA MONITOR

Display Item List

Monitored item	ALL SIGNALS	SELECTION FROM MENU	Contents
IGN ON SW	X	X	Indicates [ON/OFF] condition of ignition switch.
KEY ON SW	X	X	Indicates [ON/OFF] condition of key switch.
DOOR SW-DR	X	X	Indicates [ON/OFF] condition of front door switch LH.
LIGHT SW 1ST	X	X	Indicates [ON/OFF] condition of lighting switch.
BUCKLE SW	X	X	Indicates [ON/OFF] condition of seat belt buckle switch LH.

ACTIVE TEST

Display Item List

Test item	Malfunction is detected when...
IGN KEY WARN ALM	This test is able to check key warning chime operation.
LIGHT WARN ALM	This test is able to check light warning chime operation.
SEAT BELT WARN TEST	This test is able to check seat belt warning chime operation.

SELF-DIAG RESULTS

Display Item List

Display item [Code]	Malfunction is detected when...
CAN communication [U1000]	Malfunction is detected in CAN communication.

NOTE:

If "CAN communication [U1000]" is indicated, after printing the monitor item, go to "LAN system". Refer to [LAN-44, "TROUBLE DIAGNOSIS"](#) .

WARNING CHIME

EKS00114

Trouble Diagnosis

HOW TO PERFORM TROUBLE DIAGNOSIS

1. Confirm the symptom and customer complaint.
2. Understand the outline of system. Refer to [DI-47, "System Description"](#) .
3. Perform the preliminary inspection. Refer to [DI-53, "PRELIMINARY INSPECTION"](#) .
4. According to symptom chart, repair or replace the cause of the malfunction. Refer to [DI-53, "SYMPTOM CHART"](#) .
5. Does warning chime system operate normally? If it operates normally, GO TO 6. If not, GO TO 4.
6. Inspection End.

PRELIMINARY INSPECTION

1. CHECK BCM

Perform self-diagnosis of BCM. Refer to [DI-52, "CONSULT-II Function \(BCM\)"](#) .

Self-diagnostic results content

No malfunction detected>> GO TO 2.

Malfunction detected>> Check applicable parts, and repair or replace corresponding parts.

2. CHECK COMBINATION METER

Perform self-diagnosis of combination meter. Refer to [DI-14, "CONSULT-II Function \(METER\)"](#) .

Self-diagnostic results content

No malfunction detected>> Inspection End.

Malfunction detected>> Check applicable parts, and repair or replace corresponding parts.

SYMPTOM CHART

Symptom		Diagnoses/Service procedure
All warning chime systems do not activate.		Perform the following inspections. <ul style="list-style-type: none">● DI-54, "Combination Meter Buzzer Circuit Inspection"● DI-55, "Front Door Switch LH Signal Inspection" If above check is OK, replace BCM. Refer to BCS-27, "Removal and Installation of BCM" .
Key warning chime does not activate.	Without Intelligent Key.	Perform DI-56, "Key Switch Signal Inspection (Without Intelligent Key)" . If above check is OK, replace BCM. Refer to BCS-27, "Removal and Installation of BCM" .
	With Intelligent Key, when mechanical key is used.	Perform DI-58, "Key Switch and Ignition Knob Switch Signal Inspection (With Intelligent Key, When Mechanical Key is Used)" . If above check is OK, replace BCM. Refer to BCS-27, "Removal and Installation of BCM" .
	With Intelligent Key, when Intelligent Key is carried with the driver.	Refer to BL-123, "WARNING CHIME/BUZZER FUNCTION MALFUNCTION" .
Light warning chime does not activate.		Perform DI-59, "Lighting Switch Signal Inspection" . If above check is OK, replace BCM. Refer to BCS-27, "Removal and Installation of BCM" .

WARNING CHIME

EKS00115

Combination Meter Buzzer Circuit Inspection

1. CHECK CHIME OPERATION

1. Select "BUZZER" of "BCM" on CONSULT-II.
2. Perform "LIGHT WARN ALM" or "IGN KEY WARN ALM" of "ACTIVE TEST".

Does chime sound?

- YES >> Combination meter buzzer circuit is OK. Return to [DI-53, "SYMPTOM CHART"](#) .
- NO >> GO TO 2.

ACTIVE TEST	
LIGHT WARN ALM	OFF
ON	

SKIA6331E

2. CHECK COMBINATION METER INPUT SIGNAL

1. Select "METER" on CONSULT-II.
2. Turn on hazard switch or lighting switch while monitoring "BUZZER" of "DATA MONITOR" and check operation status.

"BUZZER"

While hazard switch or lighting switch is ON : ON and OFF repeatedly

Except above : OFF

OK or NG

- OK >> Check battery power supply circuit of combination meter. If OK, replace combination meter. Refer to [IP-19, "COMBINATION METER"](#) .
- NG >> Replace BCM. Refer to [BCS-27, "Removal and Installation of BCM"](#) .

DATA MONITOR	
MONITOR	
BUZZER	ON

PKIA2063E

WARNING CHIME

EKS00116

Front Door Switch LH Signal Inspection

1. CHECK BCM INPUT SIGNAL

With CONSULT-II

- Select "BCM".
- With "DATA MONITOR" of "BUZZER", confirm "DOOR SW-DR" when the driver's door is operated.

"DOOR SW-DR"

When driver's door is opened : ON

When driver's door is closed : OFF

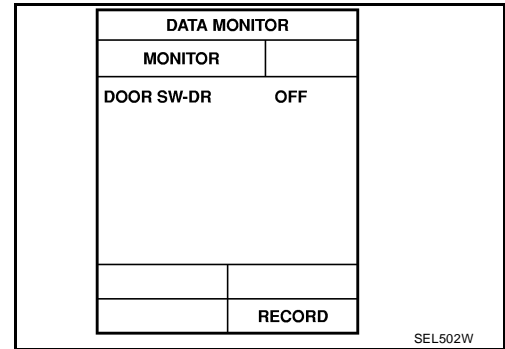

Without CONSULT-II

Check voltage between BCM harness connector and ground.

Terminals		Condition	Voltage (Approx.)
(+)	(-)		
BCM connector	Terminal		
M19	47	Driver's door is opened	0
		Driver's door is closed	Battery voltage

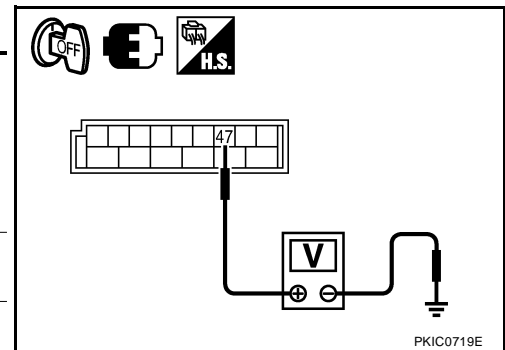

OK or NG

- OK >> Front door switch LH signal is OK. Return to [DI-53, "SYMPTOM CHART"](#).
- NG >> GO TO 2.

2. CHECK FRONT DOOR SWITCH LH CIRCUIT

- Turn ignition switch OFF.
- Disconnect BCM connector and front door switch LH connector.
- Check continuity between BCM harness connector (A) and front door switch LH harness connector (B).

A		B		Continuity
Connector	Terminal	Connector	Terminal	
M19	47	B8	2	Yes

- Check continuity between BCM harness connector (A) and ground.

A		Ground	Continuity
Connector	Terminal		
M19	47		No

OK or NG

- OK >> GO TO 3.
- NG >> Repair harness or connector.

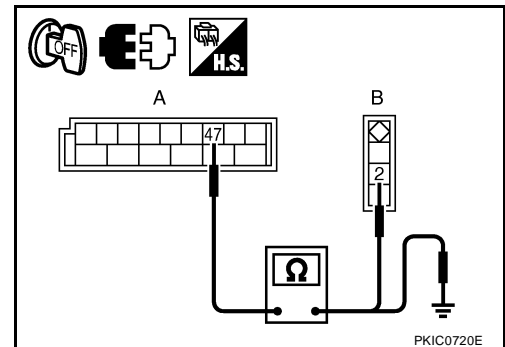

WARNING CHIME

3. CHECK FRONT DOOR SWITCH LH

Check front door switch LH. Refer to [DI-60, "FRONT DOOR SWITCH LH"](#) .

OK or NG

- OK >> Replace BCM. Refer to [BCS-27, "Removal and Installation of BCM"](#) .
- NG >> Replace front door switch LH.

Key Switch Signal Inspection (Without Intelligent Key)

EKS0017

1. CHECK FUSE

Check if the key switch and key lock solenoid 10A fuse [No. 14, located in the fuse block (J/B)] is blown.

OK or NG

- OK >> GO TO 2.
- NG >> Be sure to repair the cause of malfunction before installing new fuse. Refer to [PG-4, "POWER SUPPLY ROUTING CIRCUIT"](#) .

2. CHECK BCM INPUT SIGNAL

 **With CONSULT-II**

1. Select "BCM".
2. With "DATA MONITOR" of "BUZZER", confirm "KEY ON SW" when the key is operated.

"KEY ON SW"

When key is inserted into ignition key cylinder : ON

When key is removed from ignition key cylinder : OFF

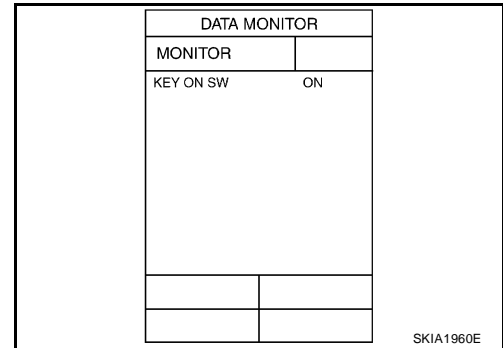

 **Without CONSULT-II**

Check voltage between BCM harness connector and ground.

Terminals		(-)	Condition	Voltage (Approx.)
(+)	Terminal			
BCM connector				
M18	37	Ground	Key is inserted	Battery voltage
			Key is removed	0 V

OK or NG

- OK >> Key switch signal is OK. Return to [DI-53, "SYMPTOM CHART"](#) .
- NG >> GO TO 3.

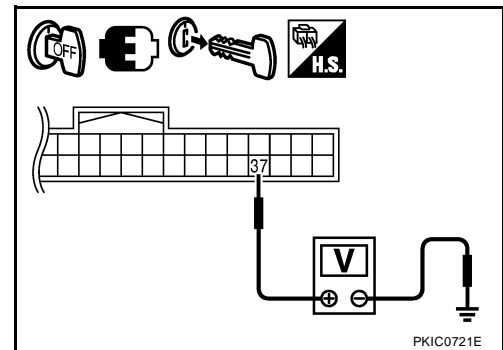

WARNING CHIME

3. CHECK KEY SWITCH

1. Turn ignition switch OFF.
2. Disconnect key switch and key lock solenoid connector.
3. Check continuity between key switch and key lock solenoid terminals 1 and 2.

Terminals		Condition	Continuity
1	2	When key is inserted into ignition key cylinder	Yes
		When key is removed from ignition key cylinder	No

OK or NG

- OK >> GO TO 4.
 NG >> Replace key switch and key lock solenoid.

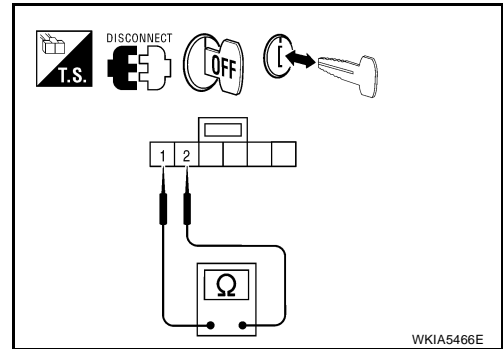

4. CHECK KEY SWITCH CIRCUIT

1. Disconnect BCM connector.
2. Check continuity between BCM harness connector (A) and key switch and key lock solenoid harness connector (B).

A		B		Continuity
Connector	Terminal	Connector	Terminal	
M18	37	M27	1	Yes

3. Check continuity between BCM harness connector (A) and ground.

A		Ground	Continuity
Connector	Terminal		
M18	37		No

OK or NG

- OK >> GO TO 5.
 NG >> Repair harness or connector.

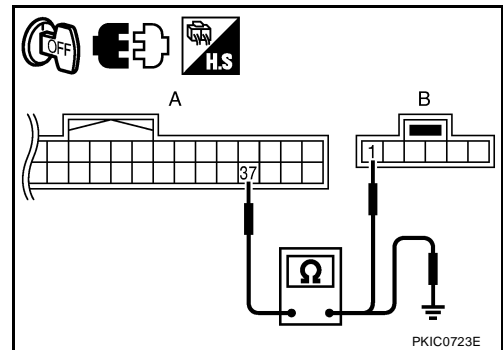

5. CHECK KEY SWITCH POWER SUPPLY CIRCUIT

Check voltage between key switch and key lock solenoid harness connector and ground.

Terminals			Voltage (Approx.)
(+)		(-)	
Key switch and key lock solenoid connector	Terminal		
M27	2	Ground	Battery voltage

OK or NG

- OK >> Replace BCM. Refer to [BCS-27, "Removal and Installation of BCM"](#) .
 NG >> Repair harness or connector.

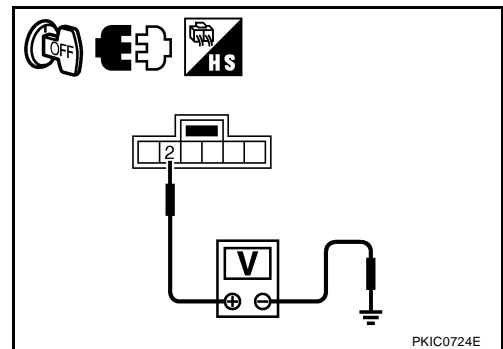

WARNING CHIME

EKS00118

Key Switch and Ignition Knob Switch Signal Inspection (With Intelligent Key, When Mechanical Key Is Used)

1. CHECK FUSE

Check if the key switch and ignition knob switch 10A fuse (No. 31, located in the fuse and fusible link box) is blown.

OK or NG

OK >> GO TO 2.

NG >> Be sure to repair the cause of malfunction before installing new fuse. Refer to [PG-4, "POWER SUPPLY ROUTING CIRCUIT"](#) .

2. CHECK BCM INPUT SIGNAL

Ⓟ With CONSULT-II

1. Select "BCM".
2. With "DATA MONITOR" of "BUZZER", confirm "KEY ON SW" when the key is operated.

"KEY ON SW"

When key is inserted into ignition key cylinder : ON

When key is removed from ignition key cylinder : OFF

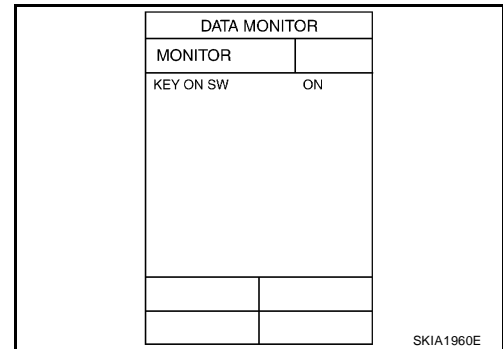

ⓧ Without CONSULT-II

Check voltage between BCM harness connector and ground.

Terminals		(-)	Condition	Voltage (Approx.)
(+)	BCM connector			
	Terminal			
M18	37	Ground	Key is inserted	Battery voltage
			Key is removed	0

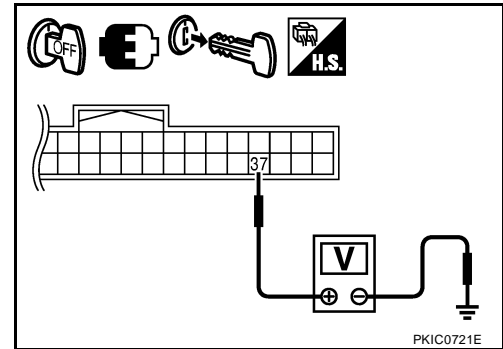

OK or NG

OK >> Key switch and ignition knob switch signal is OK. Return to [DI-53, "SYMPTOM CHART"](#) .

NG >> GO TO 3.

3. CHECK KEY SWITCH

1. Turn ignition switch OFF.
2. Disconnect key switch and ignition knob switch connector.
3. Check continuity between key switch and ignition knob switch terminals 1 and 2.

Terminals		Condition	Continuity
1	2		
		When key is inserted into ignition key cylinder	Yes
		When key is removed from ignition key cylinder	No

OK or NG

OK >> GO TO 4.

NG >> Replace key switch and ignition knob switch.

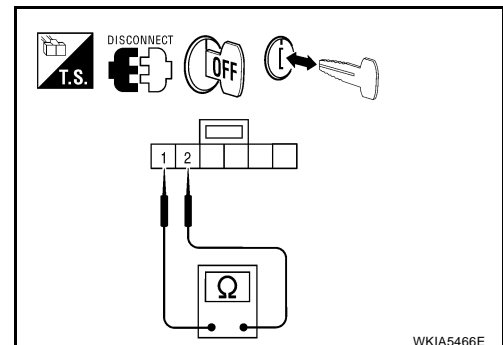

WARNING CHIME

4. CHECK KEY SWITCH CIRCUIT

1. Disconnect BCM connector.
2. Check continuity between BCM harness connector (A) and key switch and ignition knob switch harness connector (B).

A		B		Continuity
Connector	Terminal	Connector	Terminal	
M18	37	M73	1	Yes

3. Check continuity between BCM harness connector (A) and ground.

A		Ground	Continuity
Connector	Terminal		
M18	37		No

OK or NG

OK >> GO TO 5.

NG >> Repair harness or connector.

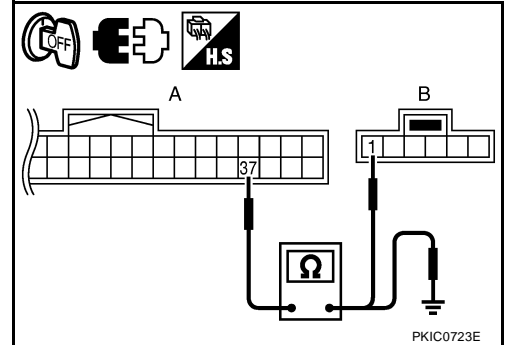

5. CHECK KEY SWITCH POWER SUPPLY CIRCUIT

Check voltage between key switch and ignition knob switch harness connector and ground.

Terminals			Voltage (Approx.)
(+)		(-)	
Key switch and ignition knob switch connector	Terminal		
M73	2	Ground	Battery voltage

OK or NG

OK >> Replace BCM. Refer to [BCS-27, "Removal and Installation of BCM"](#).

NG >> Repair harness or connector.

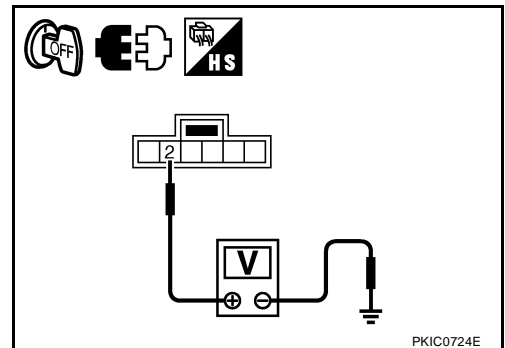

Lighting Switch Signal Inspection

1. CHECK BCM INPUT SIGNAL

1. Select "BCM".
2. With "DATA MONITOR" of "BUZZER", confirm "LIGHT SW 1ST" when the lighting switch is operated.

"LIGHT SW 1ST"

Lighting switch (1st position) : ON

Lighting switch (OFF) : OFF

OK or NG

OK >> Lighting switch signal is OK. Return to [DI-53, "SYMPTOM CHART"](#).

NG >> Check the lighting switch. Refer to [LT-68, "Combination Switch Inspection"](#).

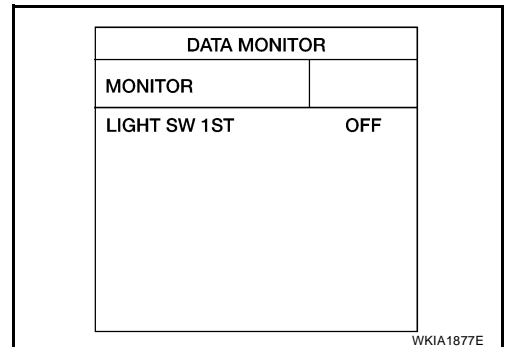

WARNING CHIME

EKS0011A

Electrical Component Inspection FRONT DOOR SWITCH LH

Check continuity between terminal 2 and door switch case ground.

Terminal		Condition	Continuity
2	Door switch case ground	When door switch is released.	Yes
		When door switch is pushed.	No

