

SECTION **LU**  
ENGINE LUBRICATION SYSTEM

A  
LU  
C  
D  
E  
F  
G  
H  
I  
J  
K  
L  
M

CONTENTS

<b>PRECAUTIONS</b> .....	2	ENGINE OIL LEAKAGE .....	5
Precautions for Liquid Gasket .....	2	OIL PRESSURE CHECK .....	5
LIQUID GASKET APPLICATION PROCEDURE.....	2	Changing Engine Oil .....	6
<b>PREPARATION</b> .....	3	<b>OIL FILTER</b> .....	8
Special Service Tools .....	3	Removal and Installation .....	8
Commercial Service Tools .....	3	REMOVAL .....	8
<b>LUBRICATION SYSTEM</b> .....	4	INSTALLATION .....	8
Lubrication Circuit .....	4	INSPECTION AFTER INSTALLATION .....	8
<b>ENGINE OIL</b> .....	5	<b>SERVICE DATA AND SPECIFICATIONS (SDS)</b> .....	9
Inspection .....	5	Standard and Limit .....	9
ENGINE OIL LEVEL .....	5	OIL PRESSURE .....	9
ENGINE OIL APPEARANCE .....	5	OIL CAPACITY .....	9

# PRECAUTIONS

## PRECAUTIONS

PF0:00001

### Precautions for Liquid Gasket

EBS00T6X

#### LIQUID GASKET APPLICATION PROCEDURE

1. Remove old liquid gasket adhering to the liquid gasket application surface and the mating surface.
  - Remove liquid gasket completely from the liquid gasket application surface, bolts, and bolt holes.
2. Wipe the liquid gasket application surface and the mating surface with white gasoline (lighting and heating use) to remove adhering moisture, grease and foreign materials.

3. Attach liquid gasket tube to the Tool.

**Use Genuine Silicone RTV Sealant or equivalent.** Refer to [GI-46, "RECOMMENDED CHEMICAL PRODUCTS AND SEALANTS"](#) .

**Tool number :WS39930000 ( — )**

- Within 5 minutes of liquid gasket application, install the mating component.
- If liquid gasket protrudes, wipe it off immediately.
- Do not retighten bolts or nuts after the installation.
- Wait 30 minutes or more after installation before refilling engine oil and engine coolant.

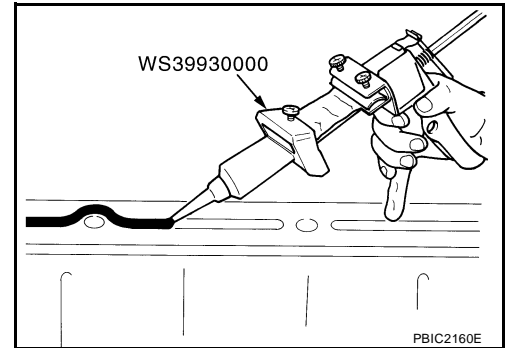

# PREPARATION

## PREPARATION

PF0:00002

### Special Service Tools

EBS00UHN

The actual shapes of Kent-Moore tools may differ from those of special service tools illustrated here.

Tool number (Kent-Moore No.) Tool name	Description
ST25051001 (J-25695-1) Oil pressure gauge	Measuring oil pressure <b>Maximum measuring range: 2,452 kPa (25 kg/cm<sup>2</sup> , 356 psi)</b>
ST25052000 (J-25695-2) Hose	Adapting oil pressure gauge to oil pan (upper)
KV10115801 (J-38956) Oil filter wrench	Removing oil filter <b>a: 64.3 mm (2.531 in)</b>
WS39930000 ( — ) Tube presser	Pressing the tube of liquid gasket

### Commercial Service Tools

EBS00UHO

Tool name	Description
Power tool	Loosening nuts and bolts
Deep socket	Removing and installing oil pressure sensor <b>a: 26 mm (1.02 in)</b>

# LUBRICATION SYSTEM

PFP:15010

EBS00770

## LUBRICATION SYSTEM

### Lubrication Circuit

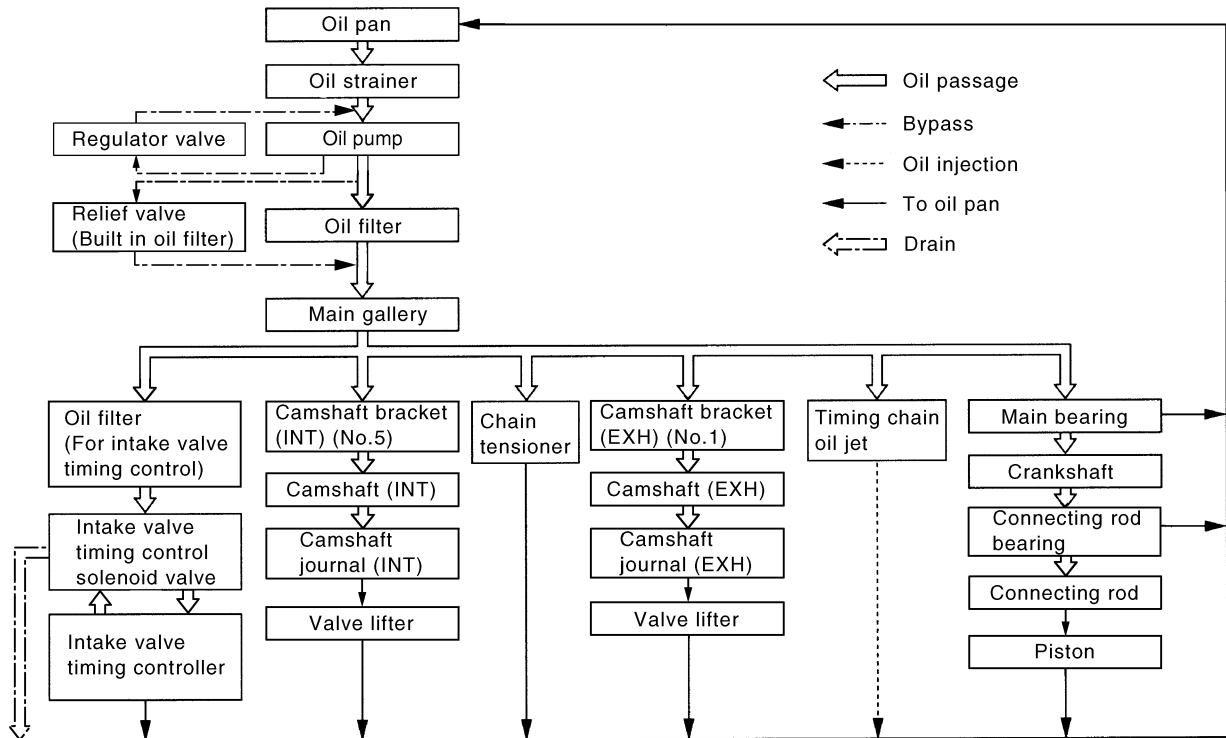
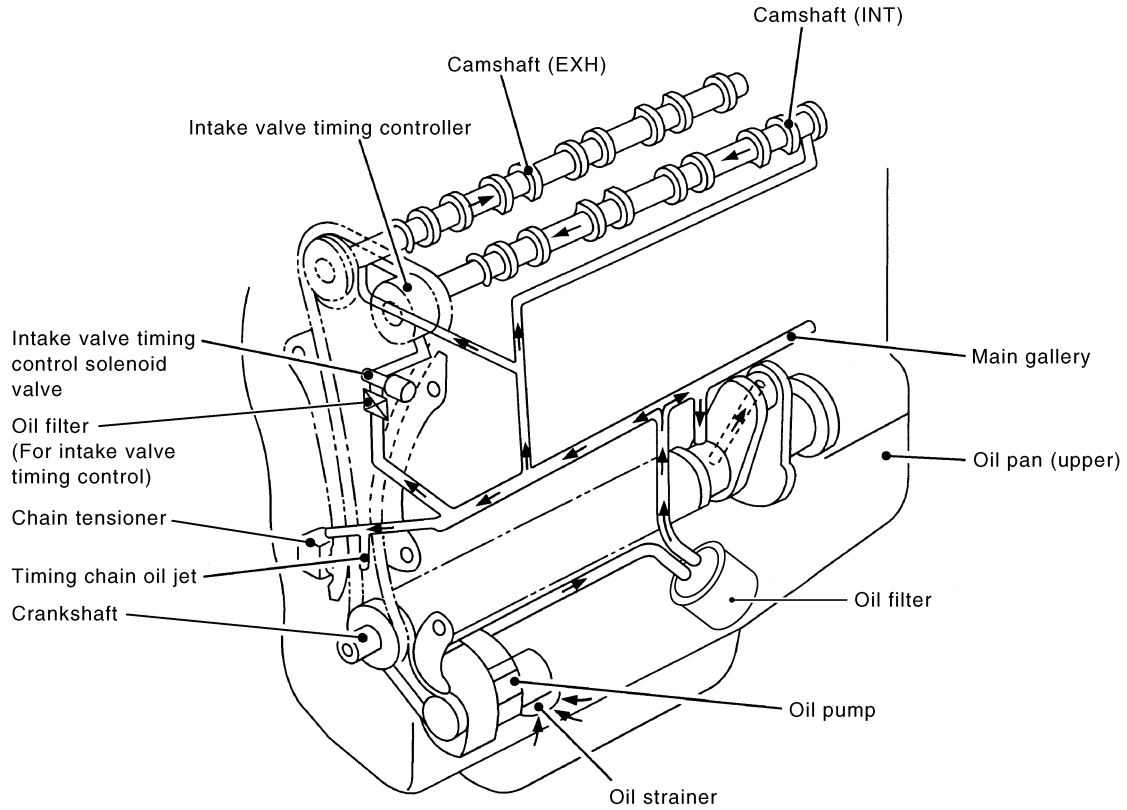

PBIC4575E

## ENGINE OIL

### Inspection ENGINE OIL LEVEL

#### NOTE:

Before starting engine, park vehicle on a level surface and check the engine oil level. If engine is already started, stop it and allow 10 minutes before checking.

1. Pull out oil level gauge and wipe it clean.
2. Insert oil level gauge and make sure the engine oil level is within the range (A) as shown.
3. If it is out of range, adjust it.

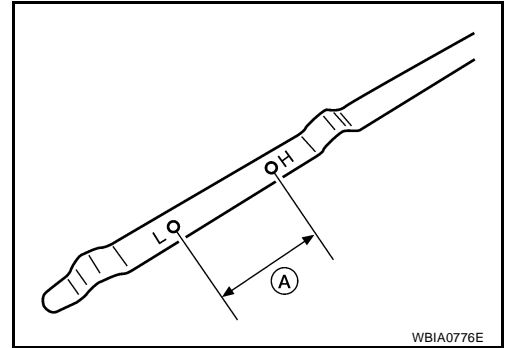

### ENGINE OIL APPEARANCE

- Check engine oil for white turbidity or heavy contamination.
- If engine oil becomes turbid and white, it is highly probable that it is contaminated with engine coolant. Repair or replace damaged parts.

### ENGINE OIL LEAKAGE

Check for engine oil leakage around the following areas:

- Oil pan (upper and lower)
- Oil pan drain plug
- Oil pressure switch
- Oil filter
- Intake valve timing control solenoid valve
- Front cover
- Mating surface between cylinder block and cylinder head
- Mating surface between cylinder head and rocker cover
- Crankshaft oil seals (front and rear)
- Oil filter (for intake valve timing control)

### OIL PRESSURE CHECK

#### WARNING:

- Be careful not to burn yourself, as engine oil may be hot.
  - For engine oil pressure check the transaxle should be in “Park position” (A/T models) and (CVT models) or “Neutral position” (M/T models), and apply the parking brake securely.
1. Disconnect harness connector at oil pressure switch (1), and remove oil pressure switch using a suitable tool.
    - Oil pan (lower) (2)
    - ← Front

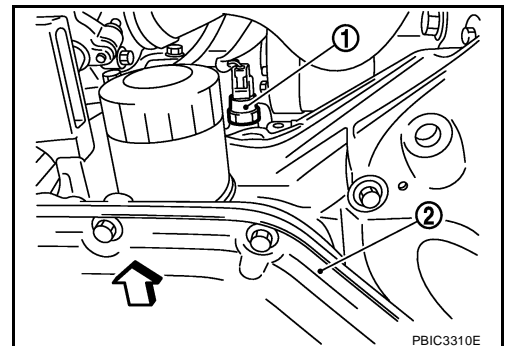

# ENGINE OIL

2. Install oil pressure gauge and hose.

**Tool number** : ST25051001 (J-25695-1)

: ST25052000 (J-25695-2)

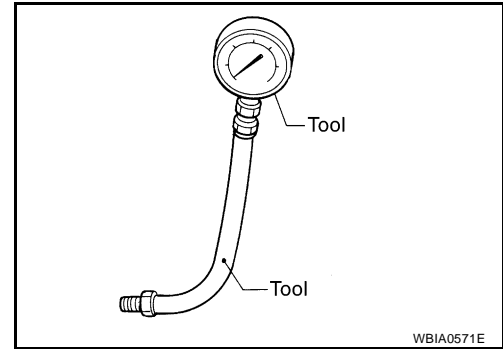

3. Check engine oil level. Refer to [LU-5, "ENGINE OIL LEVEL"](#) .

4. Start engine and warm it up to normal operating temperature.

5. Check oil pressure with engine running under no-load.

**NOTE:**

When engine oil temperature is low, engine oil pressure becomes high.

**Engine oil pressure [Engine oil temperature at 80°C (176°F)]**

Engine speed rpm	Approximate discharge pressure kPa (bar, kg/cm <sup>2</sup> , psi)
Idle speed	More than 60 (0.60, 0.61, 9)
2,000	More than 200 (2.0, 2.0, 29)

**If difference is extreme, check oil passage and oil pump for oil leaks.**

6. After the inspections, install oil pressure switch as follows:

a. Remove old liquid gasket adhering to oil pressure switch and engine.

b. Apply liquid gasket and tighten oil pressure switch to specification.

**Use Genuine Silicone RTV Sealant or equivalent.** Refer to [GI-46, "RECOMMENDED CHEMICAL PRODUCTS AND SEALANTS"](#) .

**Oil pressure switch** : 14.7 N·m (1.5 kg-m, 11 ft-lb)

c. Check engine oil level. Refer to [LU-5, "ENGINE OIL LEVEL"](#) .

d. After warming up engine, make sure there are no engine leaks of oil with running engine.

## Changing Engine Oil

EBS00772

**WARNING:**

- **Be careful not to burn yourself, as engine oil may be hot.**
  - **Prolonged and repeated contact with used engine oil may cause skin cancer; try to avoid direct skin contact with used engine oil. If skin contact is made, wash thoroughly with soap or hand cleaner as soon as possible.**
1. Warm up engine, park vehicle on a level surface and check for engine oil leakage from engine components. Refer to [LU-5, "ENGINE OIL LEAKAGE"](#) .
  2. Stop engine and wait for 10 minutes.

## ENGINE OIL

3. Loosen oil filler cap (1) and then remove drain plug (2).
    - Oil filter (3)
    - ← Engine front
  4. Drain engine oil.
  5. Install drain plug (2) with new washer. Refer to [EM-24, "Components"](#).
- CAUTION:**  
Be sure to clean drain plug (2) and install with new washer.
6. Refill with new engine oil.  
Refer to [MA-11, "RECOMMENDED FLUIDS AND LUBRICANTS"](#).
- CAUTION:**
- The refill capacity depends on the engine oil temperature and drain time. Use these specifications for reference only.
  - Always use oil level gauge to determine the proper amount of engine oil in the engine.
7. Warm up engine and check area around drain plug (2) and oil filter (3) for engine oil leakage.
  8. Stop engine and wait for 10 minutes.
  9. Check the engine oil level. Refer to [LU-5, "ENGINE OIL LEVEL"](#).

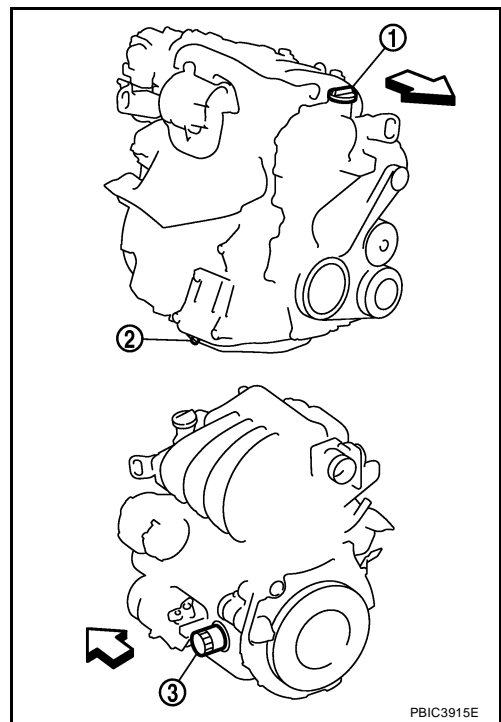

A

LU

C

D

E

F

G

H

I

J

K

L

M

# OIL FILTER

PF15208

EBS0073

## OIL FILTER

### Removal and Installation

#### REMOVAL

1. Remove oil filter using Tool (A).

**Tool number** : KV10115801 (J-38956)

- ⇐ Front

#### CAUTION:

- Oil filter is provided with relief valve. Use Genuine NISSAN Oil Filter or equivalent.
- Be careful not to get burned when engine and engine oil may be hot.
- When removing, prepare a shop cloth to absorb any engine oil leakage or spillage.
- Do not allow engine oil to adhere to drive belt.
- Completely wipe off any engine oil that adheres to engine and vehicle.

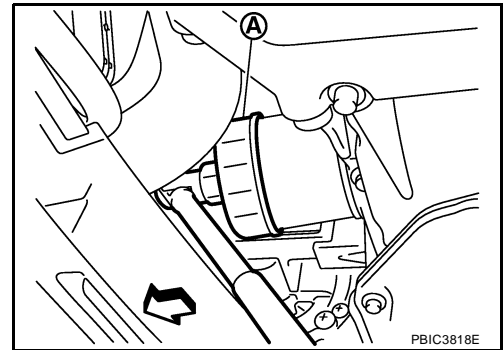

#### INSTALLATION

1. Remove foreign materials adhering to the oil filter installation surface.
2. Apply new engine oil to the oil seal contact surface of new oil filter.

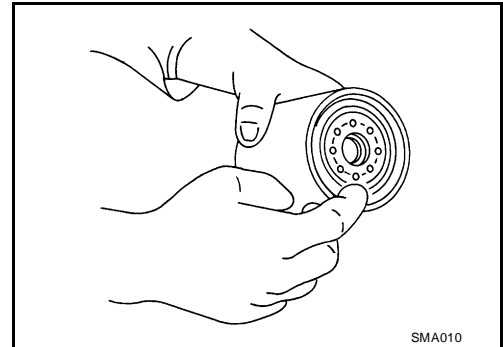

3. Screw oil filter manually until it touches the installation surface, then tighten it by 2/3 turn. Or tighten to specification.

**Oil filter:** : 17.7 N·m (1.8 kg·m, 13 ft·lb)

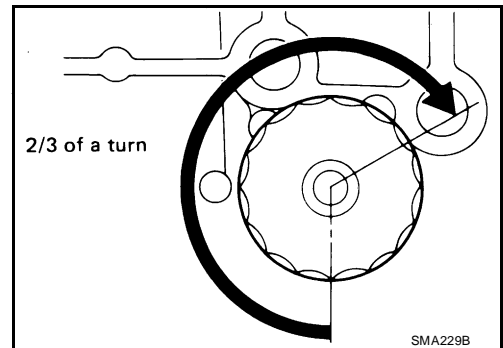

#### INSPECTION AFTER INSTALLATION

1. Check the engine oil level. Refer to [LU-5, "ENGINE OIL"](#) .
2. Start engine, and make sure there is no leaks of engine oil.
3. Stop engine and wait for 10 minutes.
4. Check the engine oil level and adjust engine oil. Refer to [LU-5, "ENGINE OIL"](#) .



# SERVICE DATA AND SPECIFICATIONS (SDS)

## SERVICE DATA AND SPECIFICATIONS (SDS)

PFP:00030

### Standard and Limit OIL PRESSURE

EBS00774

Engine speed rpm	Approximate discharge pressure kPa (bar, kg/cm <sup>2</sup> , psi)
Idle speed 2,000	60 (0.60, 0.61, 9) 200 (2.0, 2.0, 29)

### OIL CAPACITY

Unit: ℓ (US qt, Imp qt)

Drain and refill	With oil filter change	Approximately 3.9 (4 1/8, 3 3/8)
	Without oil filter change	Approximately 3.7 (3 7/8, 3 1/4)
Dry engine (engine overhaul)		Approximately 4.9 (5 1/8, 4 3/8)

A

LU

C

D

E

F

G

H

I

J

K

L

M

# SERVICE DATA AND SPECIFICATIONS (SDS)

---